

FAMILY SPRINT

NEW

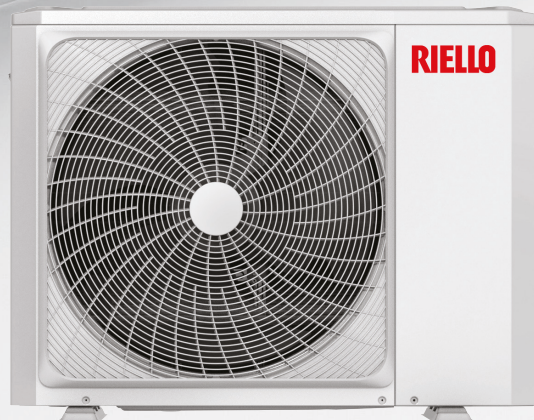

Air-to-water split wall-hung R32 Heat Pumps

FAMILY SPRINT **THE NEW RANGE OF** **AIR-TO-WATER SPLIT** **WALL-HUNG HEAT PUMPS**

FAMILY SPRINT split heat pumps are designed to provide heating, cooling and domestic hot water.

Available in 10 power sizes, they offer a wide choice of single-phase models from 4 to 16 kW and three-phase models from 12 to 16 kW.

Thanks to the compressor with DC Inverter technology, they offer a heating temperature of up to 65°C. On-board control as standard allows easy management of different functions.



ALL SEASONS COMFORT



EFFICIENT PERFORMANCE



QUIET OPERATION

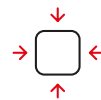

COMPACT DIMENSIONS



R32 REFRIGERANT GAS



WIDE RANGE

EFFICIENCY AND RESPECT FOR THE ENVIRONMENT

FAMILY SPRINT split heat pumps use R32 gas, which has a lower Global Warming Potential (GWP) than R410A gas.

FAMILY SPRINT is respectful of the environment, thanks to the use of the R32 refrigerant gas and the increased energy efficiency(*).

(*) Compared with the previous range of FAMILY ES split heat pumps with R410A gas.



ENERGY CLASS A+++

Since the European ErP Directive's entry into force (09/26/2015), heat pumps, like other generators for the production of heating and domestic hot water, were also required to be classified through the appropriate energy label indicating the class. The mandatory labeling provides greater transparency on the characteristics of the products, which are able to be easily compared, favoring the user in searching for those with higher efficiency.

FAMILY SPRINT heat pumps achieve class A+++ (A7°C; W35°C).

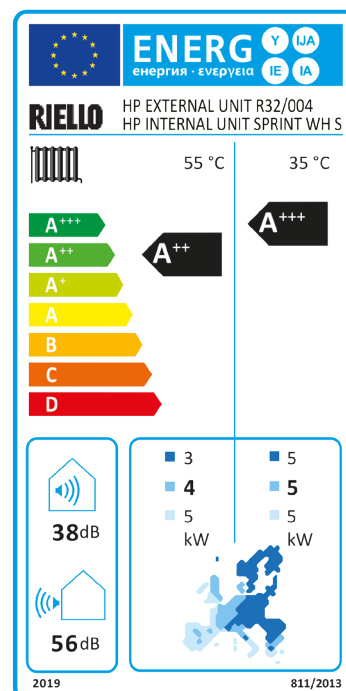

HOW DOES FAMILY SPRINT WORK?

FAMILY SPRINT is an air-to-water split heat pump that harnesses thermal energy from the air, a renewable and free source, by extracting it through the outdoor unit, and domestic electricity to provide comfort in all seasons, producing heating,

cooling, and domestic hot water. Through an Inverter compressor and the refrigerant gas, thermal energy from the air is transferred to the water for DHW use and to the circuit water of the floor heating system, fan coil units, and radiators.

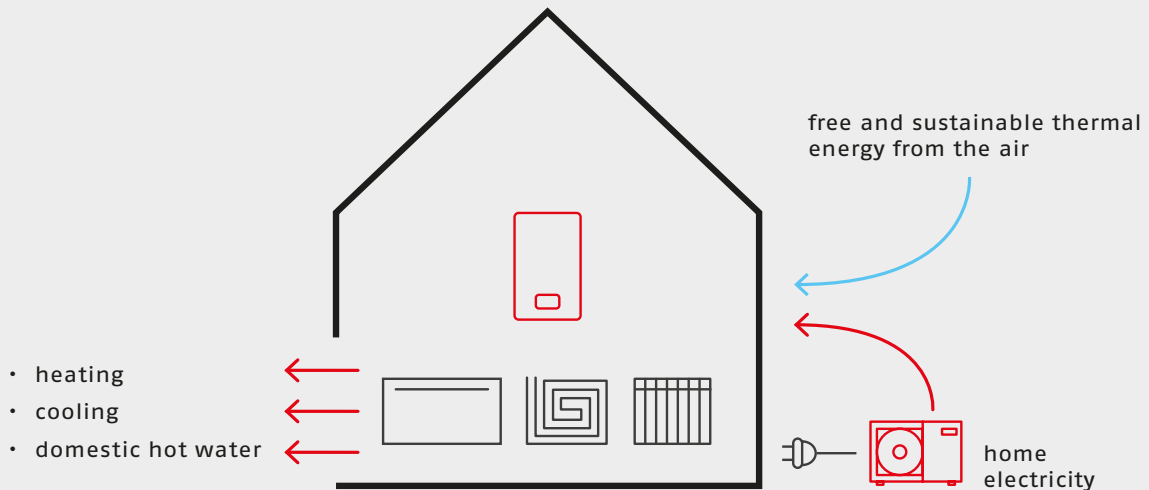

THE STRENGTHS OF FAMILY SPRINT



QUIET OPERATION

The low noise level is achieved thanks to the construction measures employed and can be reduced by up to 39 dB(A)* by setting the Silent Mode, which can be activated by the customer.



EFFICIENT PERFORMANCE

All sizes of FAMILY SPRINT feature the energy class A+++ in heating (air 7°C, water 35°C) and can reach a central heating temperature of up to 65°C.

* sound pressure of 4 kW model in Silent Mode 2

RESPECT FOR THE ENVIRONMENT



The new FAMILY SPRINT range uses R32 refrigerant gas, which offers several advantages compared with R410A refrigerant and complies with the current European targets for **CO₂ emissions** reduction.

THE PLUSES OF R32 REFRIGERANT

- Low Global Warming Potential (GWP): R410A: 2.088 > R32: 675
- Improved Energy Efficiency compared to products operating with R410A
- Proven and reliable solution, already used in residential air conditioners (MILLIONS OF ACS IN USE, including Riello AARIA MONO PLUS and AARIA MULTI PLUS)



TECHNOLOGY: FUNCTIONAL ELEMENTS

4-6 KW

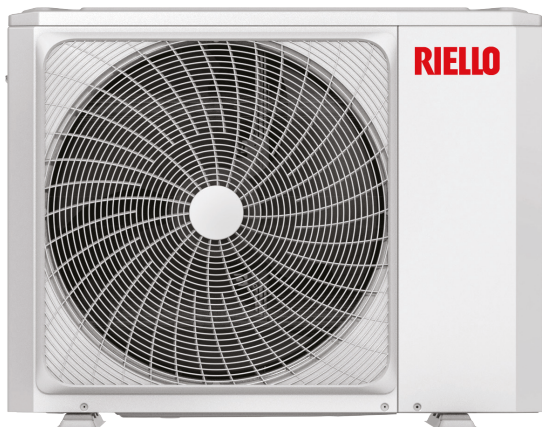

8-16 KW

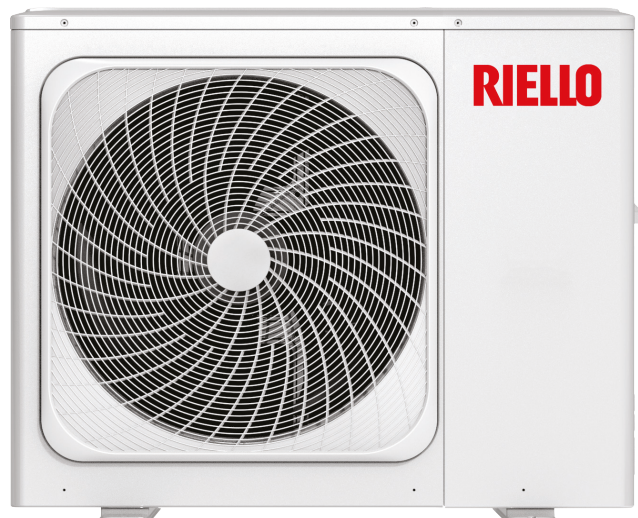

- **INVERTER CONTROL BOARD** maximises power under critical load conditions and provides stability and efficiency at partial loads
- **AISI 316 STAINLESS STEEL PLATE HEAT EXCHANGER:** protected with closed-cell anti-condensation insulation offers high heat exchange efficiency
- **OPERATING PARAMETER CONTROL BOARD** constantly analyses room and water temperature to activate the various components and meet demand
- **ELECTRONIC EXPANSION VALVE** optimises the refrigerant flow
- **TWIN ROTARY COMPRESSOR** The Inverter System design including the twin DC rotary compressor, fan motor and pump ensures precise control of the motor speed for the right power to match the actual load and save energy
- **FAN** Special design of the blade and its edge optimises the flow surface, improving efficiency and reducing fan noise
- **HEAT EXCHANGE BATTERY** with extended surface area and aluminium wings

POWER INPUT LIMITATION

FAMILY SPRINT is equipped with the "Power Input Limitation" function, which allows the user to limit the power input of the home system, thus helping to avoid unpleasant power cuts if several appliances are running in the house at the

same time. In fact, the new heat pump offers 9 different levels, which you can easily* select from the control panel according to the power profile of your electric supply.

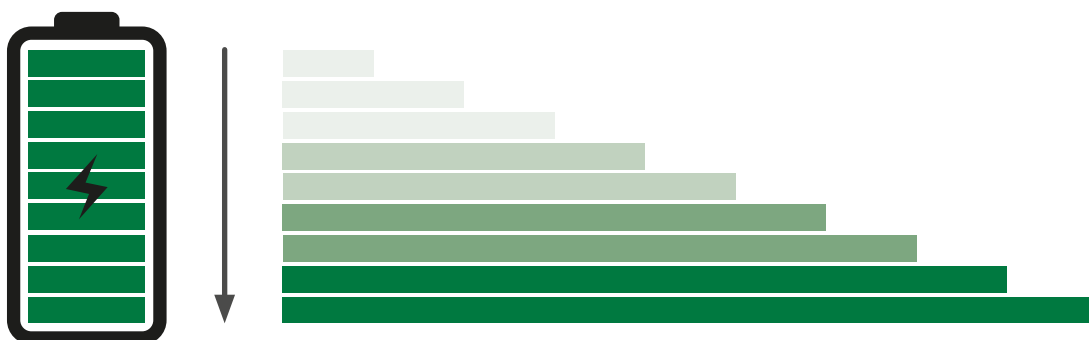

*the setting of the desired level will be carried out during the first installation and can be changed later by contacting technical support.

ONBOARD CONTROL AS STANDARD

The on-board control is supplied as standard with each heat pump split system indoor unit. Easy to navigate, it allows you, among others, to activate all available functions, such as "Antifreeze" and "Holiday", and set the weekly programming for home comfort management. The large backlit display features intuitive icons that simplify reading, which is also made easier by the multi-language menu.



INSTALLATION FLEXIBILITY

FAMILY SPRINT, characterised by a compact indoor unit, represents a valid solution both as a replacement of a wall-hung gas boiler, and for new housing, that can be combined with a Riello gas boiler. In colder climates, the gas boiler can represent an auxiliary heat source.

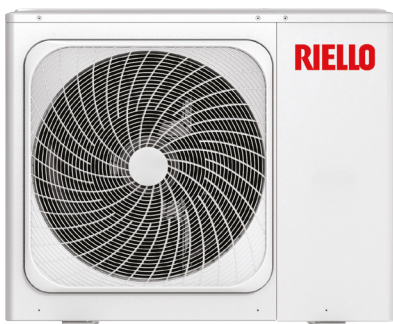
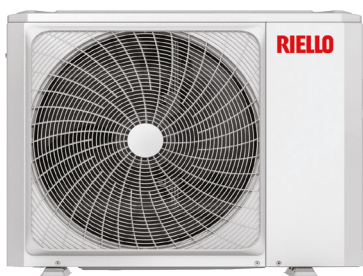

AUXILIARY HEAT SOURCES



WALL-HUNG CONDENSING BOILER

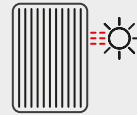

SOLAR COLLECTOR, FOR THE PRODUCTION OF DHW

TERMINAL UNITS

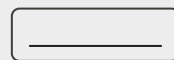

FAN COILS



UNDER-FLOOR HEATING

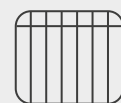

RADIATORS

ACCESSORIES AND SYSTEM COMPLEMENTARY ITEMS FOR DIFFERENT REQUIREMENTS

FAMILY SPRINT split heat pumps are designed for home comfort and for combination with different system complementary items for heating and cooling, such as Riello fan coils. Thanks to the wideness of the range, which includes models from 4 to 16 kW, the FAMILY SPRINT allows you to meet different system requirements. Furthermore, it is possible to choose between indoor units with and without additional back up heater.

This extensive proposal is the answer for those who want an additional heating element in order to increase power without upgrading to a larger model. The additional resistance, on the models that include it, is already mounted on the unit, to simplify the installation of the whole heat pump system.

DISCOVER OUR RANGE OF FAN COILS ON RIELLO WEB SITE.

DESIGN WALL



DESIGN INVERTER

DESIGN INVERTER

DESIGN WALL

FAMILY SPRINT
wall-hang indoor unit

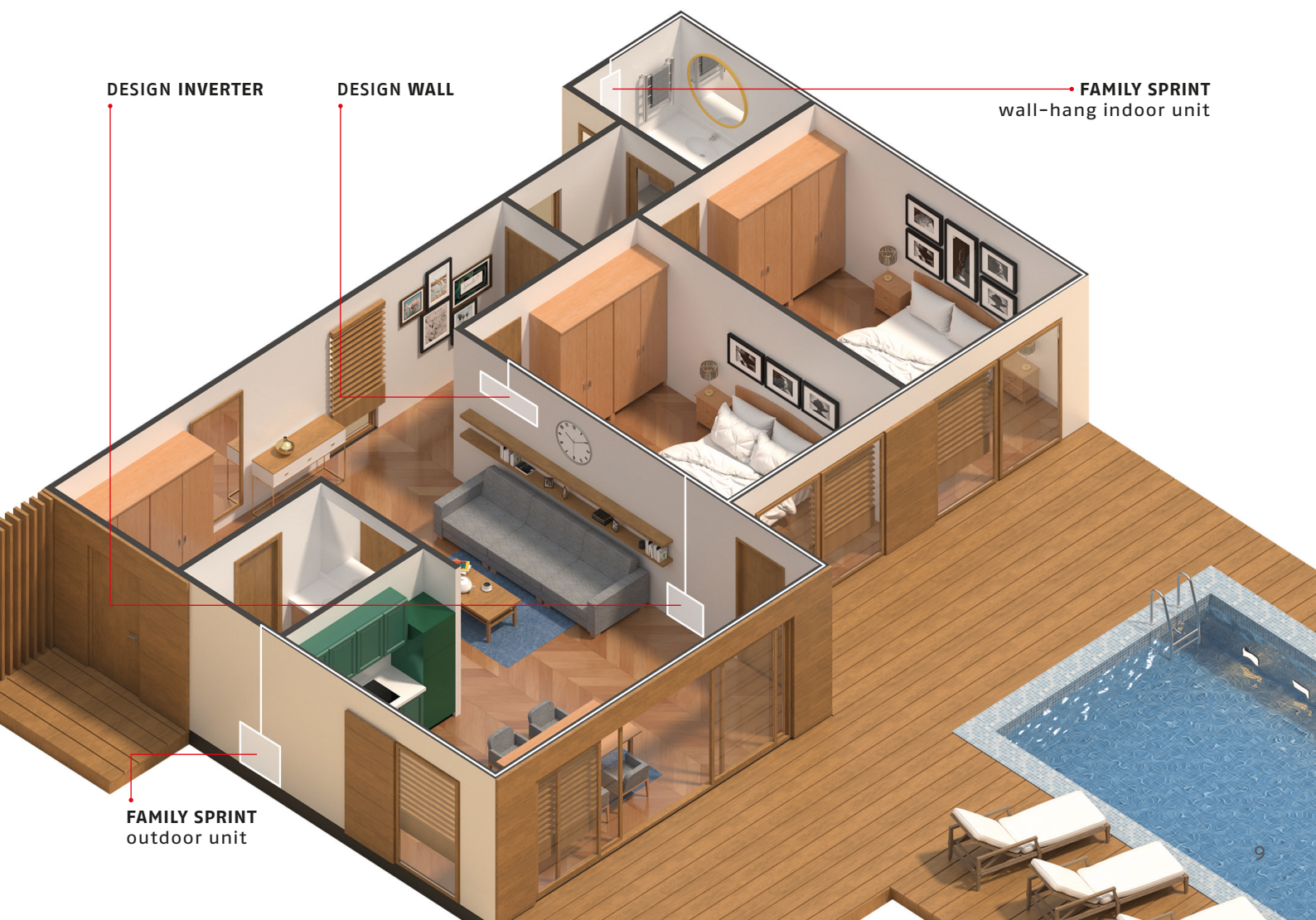

FAMILY SPRINT
outdoor unit

COMFORT FOR ALL SEASONS

The FAMILY SPRINT heat pump range can be used with a wide range of outside air temperatures.

As the graphs show, in heating mode it can operate from -25°C outside air temperature, in cooling mode up to $+43^{\circ}\text{C}$ and for domestic hot water from -5°C to $+43^{\circ}\text{C}$ outside air temperature.



OPERATING LIMITS

■ Operating range only with gas boiler or electric resistance

■ Operating range via heat pump with possible limitation and protection

--- Maximum water inlet temperature line for heat pump operation

T_{w_out} = water flow temperature
 T_4 = outdoor air temperature

COOLING MODE

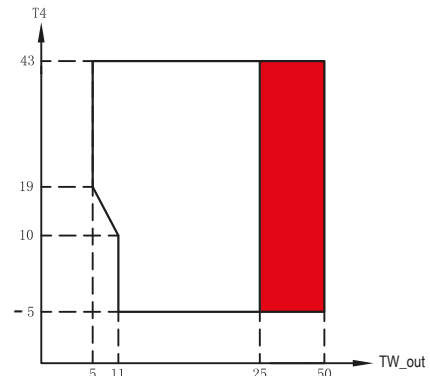

HEATING MODE

The maximum water outlet temperature (T_{w_out}) that the heat pump can reach at different outside temperatures (T_4) is listed below:

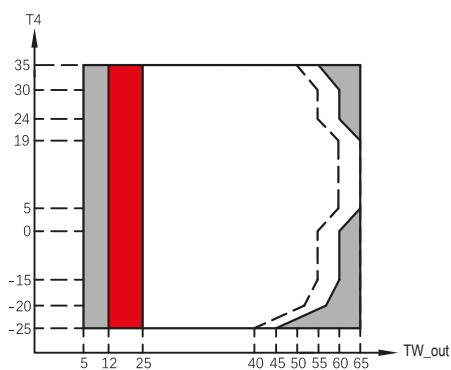

DHW MODE

The maximum water outlet temperature (T_{w_out}) that the heat pump can reach at different outside temperatures (T_4) is listed below:

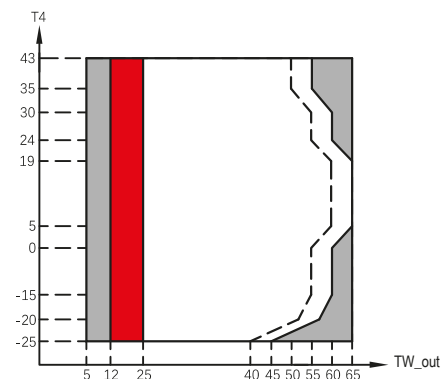

ACCESSORIES

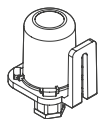

OUTDOOR AIR PROBE

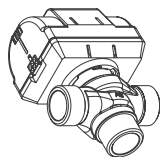

3-WAY DIVERTER VALVE
(1" AND 1/4 AND 1")

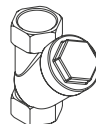

1" Y-FILTER

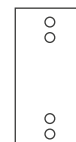

TANK
FOR DHW PRODUCTION

TECHNICAL DRAWINGS

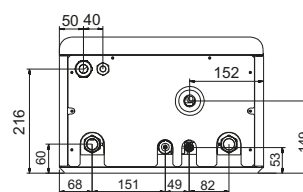
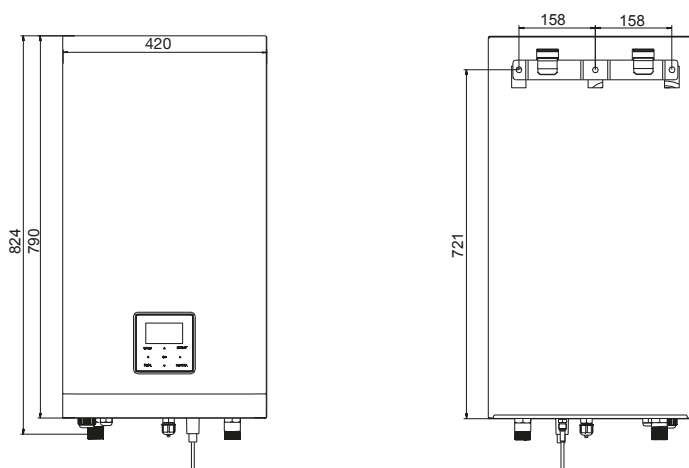

L x W x D: 420x790x270MM

4-6 KW

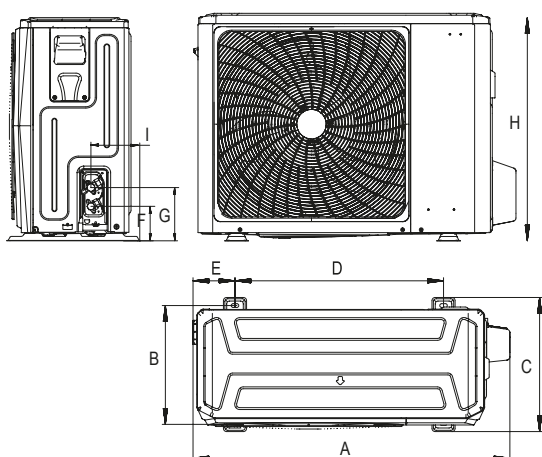

8-16 KW

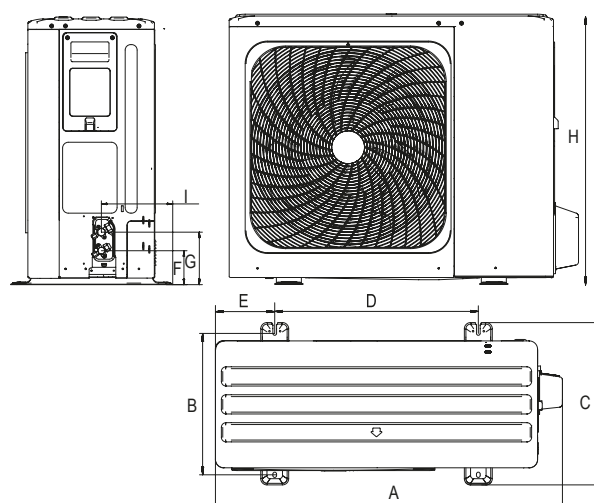

Model	uom	A	B	C	D	E	F	G	H	K
4-6 kW	mm	1008	375	426	663	134	110	170	712	160
8-10-12-14-16 kW	mm	1118	456	523	656	191	110	170	865	230

TYPICAL APPLICATION EXAMPLES

Example of a system with FAMILY SPRINT and auxiliary heating source for floor heating and DHW production via DHW tank and solar thermal

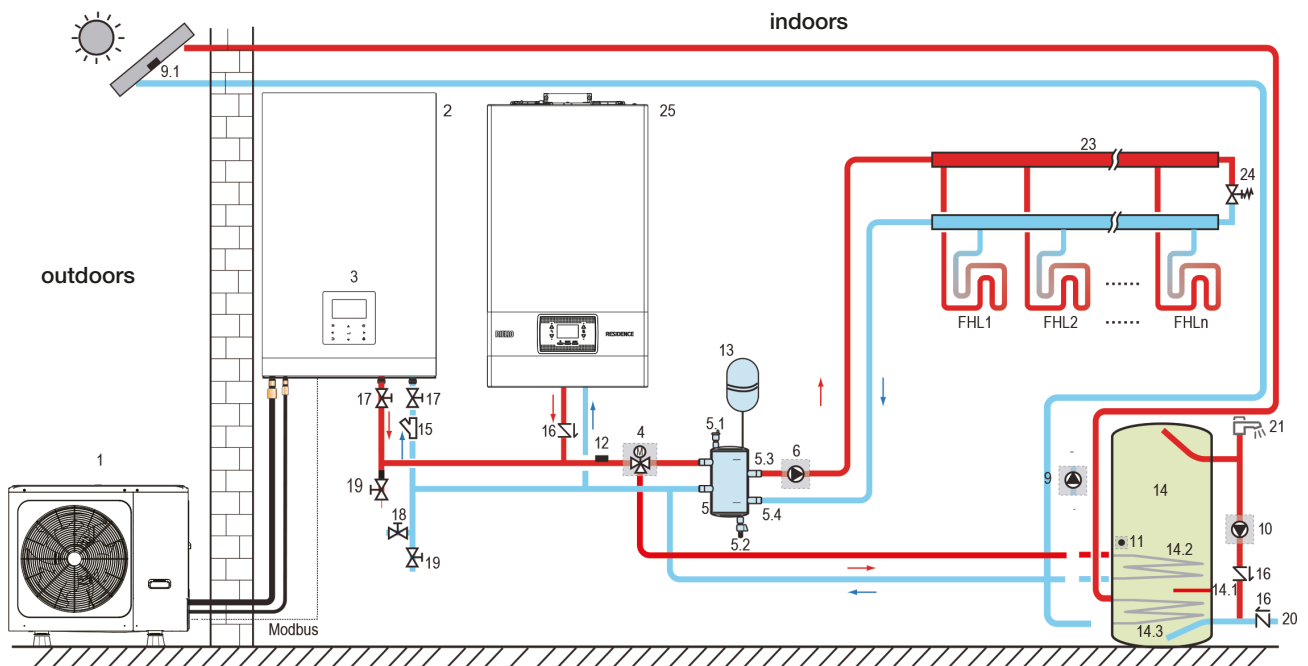

- | | | | |
|-------------------------------------|-------------------------------------|----------------------------------|--|
| 1 Outdoor unit | 5.2 Drain valve | 17 Shut-off valve* | 25 Beretta wall-hung gas boiler** |
| 2 Indoor unit | 6 External circulation pump* | 18 Filling valve* | RT8 High-voltage room thermostat |
| 3 End user interface | 7 SV2: 3-way-valve* | 19 Drain valve* | FHL 1... n Floor heating circuit* |
| 5 Buffer tank * | 13 Expansion vessel* | 23 Collector/distributor* | FCU 1... n Fan coil* |
| 5.1 Automatic air vent valve | 15 Filter (Accessory) | 24 Bypass valve* | |

*to be purchased separately

**check compatibility with the individual gas boiler model selected

Example of a system with FAMILY SPRINT for heating, via floor heating, and cooling, via fan coil units

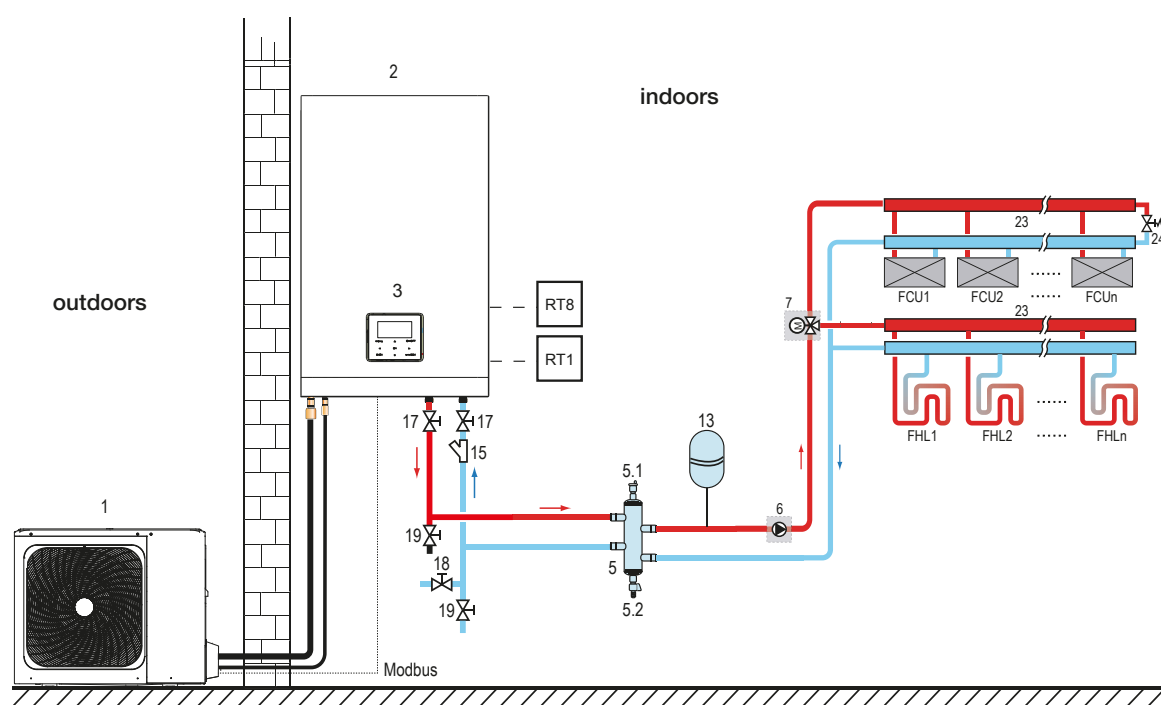

- | | | | |
|-------------------------------------|-------------------------------------|----------------------------------|--|
| 1 Outdoor unit | 5.2 Drain valve | 17 Shut-off valve* | RT8 High-voltage room thermostat |
| 2 Indoor unit | 6 External circulation pump* | 18 Filling valve* | FHL 1... n Floor heating circuit* |
| 3 End user interface | 7 SV2: 3-way-valve* | 19 Drain valve* | FCU 1... n Fan coil* |
| 5 Buffer tank * | 13 Expansion vessel* | 23 Collector/distributor* | |
| 5.1 Automatic air vent valve | 15 Filter (Accessory) | 24 Bypass valve* | |

*to be purchased separately

TECHNICAL DATA

U.M. 004 006 008 010 012 014 016 012T 014T 016T

PERFORMANCE DATA

PERFORMANCE IN HEATING [A7/W35] (1)

Nominal heating capacity	kW	4,25	6,20	8,30	10,00	12,10	14,50	16,00	12,10	14,50	16,00
COP	kW/kW	5,20	5,00	5,20	5,00	4,95	4,70	4,50	4,95	4,70	4,50
SCOP	kW/kW	4,85	4,95	5,22	5,20	4,81	4,72	4,62	4,81	4,72	4,62
ηs	%	191	195	206	205	189	186	182	189	186	182
Seasonal energy class		A+++	A+++	A+++	A+++	A+++	A+++	A+++	A+++	A+++	A+++

PERFORMANCE IN HEATING [A7/W45] (2)

Nominal heating capacity	kW	4,35	6,35	8,20	10,00	12,30	14,20	16,00	12,30	14,20	16,00
COP	kW/kW	3,80	3,75	3,95	3,80	3,80	3,65	3,60	3,80	3,65	3,60

PERFORMANCE IN HEATING [A7/W55] (3)

Nominal heating capacity	kW	4,40	6,00	7,50	9,50	12,00	13,80	16,00	12,00	13,80	16,00
COP	kW/kW	2,95	3,00	3,18	3,10	3,10	3,00	2,90	3,10	3,00	2,90
SCOP	kW/kW	3,31	3,52	3,37	3,47	3,45	3,47	3,41	3,45	3,47	3,41
ηs	%	130	138	132	137	135	136	133	135	136	133
Seasonal energy class		A++	A++	A++	A++	A++	A++	A++	A++	A++	A++

PERFORMANCE IN COOLING (A35/W18) (4)

Nominal cooling capacity	kW	4,50	6,55	8,40	10,00	12,00	13,50	14,20	12,00	13,50	14,20
EER		5,55	4,90	5,05	4,80	4,00	3,61	3,61	4,00	3,61	3,61
SEER		7,77	8,21	8,95	8,78	7,10	6,90	6,75	7,04	6,85	6,71

PERFORMANCE IN COOLING (A35/W7) (5)

Nominal cooling capacity	kW	4,70	7,00	7,40	8,20	11,60	12,70	14,00	11,60	12,70	14,00
EER		3,45	3,00	3,38	3,30	2,75	2,55	2,45	2,75	2,55	2,45
SEER		4,99	5,34	5,83	5,98	4,89	4,86	4,69	4,86	4,83	4,67

SOUND LEVELS

Sound pressure (6) - outdoor unit	dB(A)	44	45	46	49	50	51	54	50	51	55
Sound power (7) - outdoor unit	dB(A)	56	58	59	60	64	65	68	64	65	68
Sound pressure (6) - indoor unit	dB(A)	28	28	30	30	32	32	32	32	32	32
Sound power (7) - indoor unit	dB(A)	38	38	40	40	42	44	44	42	44	44

ELECTRICAL CHARACTERISTICS

Power supply	V/ph/Hz	220-240/1/50						380-415/3/50			
Permitted voltage	V	220-240						380-415			
Total power input (8)	kW	2,2	2,6	3,3	3,6	5,4	5,7	6,1	5,4	5,7	6,1
Full load current (9)	A	12	14	16	17	25	26	27	10	11	12
Refrigerant		R32									
Refrigerant charge	kg	1,5			1,65			1,84			
Compressor type		DC inverter dual rotary									
Outdoor fan type		DC motor/horizontal									
Number of fans		1									
Air side heat exchanger		Fin coil									
Water side heat exchanger		Plate type									

(1) Outside air temperature 7°C DB; water inlet/outlet 30/35°C

(2) Outside air temperature 7°C DB; water inlet/outlet 40/45°C

(3) Outside air temperature 7°C DB; water inlet/outlet 47/55°C

(4) Outside air temperature 35°C; water inlet/outlet 23/18°C

(5) Outside air temperature 35°C; water inlet/outlet 12/7°C

(6) Measured at a position 1m in front of the unit and (1+unit height)/2m above the floor in semi-anechoic chamber

(7) Declared value in compliance with the EN 12102-1

(8) Power absorbed by the compressors and fans at the limit operating conditions with a rated supply voltage

(9) Maximum circuit amps

 Performance are declared according to relevant EU standards and legislation: EN14511; EN14825; EN50564; EN12102; (EU) No 811/2013; (EU) No 813/2013; OJ 2014/C 207/02.

U. M. 004 006 008 010 012 014 016 012T 014T 016T
PERFORMANCE BASED ON THE CLIMATIC ZONE
AVERAGE ZONE – AVERAGE TEMPERATURE [4/7/55°C]

ηs	%	129,5	137,9	131,5	136,6	135,1	135,6	133,3	135,1	135,6	133,2
SCOP	kW/kW	3,31	3,52	3,37	3,47	3,45	3,47	3,41	3,45	3,47	3,41
Pdesign -7°C	kW	3,89	5,04	5,84	6,78	10,24	10,68	11,52	10,24	10,68	11,52
Pdesign +2°C	kW	2,38	3,12	3,76	4,28	6,52	6,86	7,18	6,52	6,86	7,18
Pdesign +7°C	kW	2,94	2,08	2,43	2,77	4,36	4,63	4,67	4,36	4,63	4,67
Pdesign +12°C	kW	1,32	1,28	1,39	1,58	3,29	3,31	3,31	3,29	3,31	3,32
Annual energy consumption	kWh	2,74	3,34	4,05	4,53	6,92	7,20	7,89	6,92	7,20	7,89
Energy class		A++	A++	A++	A++	A++	A++	A++	A++	A++	A++
Indoor sound power level	dB(A)	38	38	42	42	43	43	43	43	43	43
Outdoor sound power level	dB(A)	56	58	59	60	64	65	68	64	65	68

AVERAGE ZONE – LOW TEMPERATURE [30/35°C]

ηs	%	191	195	205,6	204,8	189,4	185,7	181,7	189,3	185,6	181,6
SCOP	kW/kW	4,85	4,95	5,22	5,2	4,81	4,72	4,62	4,81	4,72	4,62
Pdesign -7°C	kW	4,88	6,03	7,18	8,1	10,61	12,14	13,45	10,61	12,14	13,45
Pdesign +2°C	kW	3,05	3,88	4,65	5,18	6,69	7,94	8,56	6,69	7,94	8,56
Pdesign +7°C	kW	1,93	2,39	2,9	3,32	4,44	5,2	5,7	4,44	5,2	5,7
Pdesign +12°C	kW	1,48	1,39	1,63	1,65	3,74	3,75	3,78	3,74	3,75	3,78
Annual energy consumption	kWh	2,35	2,84	3,21	3,64	5,15	6,01	6,80	5,15	6,01	6,80
Energy class		A+++	A+++	A+++	A+++	A+++	A+++	A+++	A+++	A+++	A+++
Indoor sound power level	dB(A)	38	38	42	42	43	43	43	43	43	43
Outdoor sound power level	dB(A)	56	58	59	60	64	65	68	64	65	68

WARM ZONE – AVERAGE TEMPERATURE [4/7/55°C]

ηs	%	162,4	164,7	176,9	180,3	174	174,9	176	173,8	174,7	175,8
Pdesign +2°C	kW	4,83	5,02	7,55	8,06	12,07	13,04	13,38	12,07	13,04	13,38
Pdesign +7°C	kW	3,22	3,31	5,38	5,54	8,04	9,11	9,11	8,04	9,11	9,11
Pdesign +12°C	kW	1,47	1,59	2,31	2,53	3,75	4,08	4,06	3,75	4,08	4,06
Annual energy consumption	kWh	1,62	1,64	2,48	2,51	3,77	4,25	4,23	3,78	4,23	4,23

WARM ZONE – LOW TEMPERATURE [30/35°C]

ηs	%	255,4	259,8	276,6	280,5	256,1	260,3	248,5	255,6	259,8	248,1
Pdesign +2°C	kW	5,34	5,93	7,56	8,44	11,1	12,04	13,1	11,1	12,04	13,1
Pdesign +7°C	kW	3,56	3,93	5,22	5,52	7,14	7,78	8,41	7,14	7,78	8,41
Pdesign +12°C	kW	1,63	1,79	2,62	2,62	3,55	3,75	3,87	3,55	3,75	3,87
Annual energy consumption	kWh	1,14	1,24	1,55	1,61	2,29	2,45	2,78	2,29	2,46	2,78

COLD ZONE – AVERAGE TEMPERATURE [4/7/55°C]

ηs	%	102,1	111,1	112	116,4	117,8	118,9	121,8	117,7	118,9	121,8
Pdesign -7°C	kW	2,13	2,7	3,86	4,27	6,63	6,89	7,64	6,63	6,89	7,64
Pdesign +2°C	kW	1,28	1,6	2,21	2,57	4,06	4,32	4,42	4,06	4,32	4,42
Pdesign +7°C	kW	1,01	1,02	1,44	1,65	2,78	3,06	2,97	2,78	3,06	2,97
Pdesign +12°C	kW	1,36	1,37	1,46	1,47	3,33	3,33	3,43	3,33	3,33	3,43
Annual energy consumption	kWh	3,15	3,68	4,95	5,54	8,41	8,86	9,30	8,42	8,86	9,31

COLD ZONE – LOW TEMPERATURE [30/35°C]

ηs	%	159,5	165,3	170	169,8	160,2	159,6	157,8	160,2	159,6	157,8
Pdesign -7°C	kW	2,75	3,42	4,46	4,83	7,05	7,96	8,31	7,05	7,96	8,31
Pdesign +2°C	kW	1,77	2,06	2,69	2,94	4,67	5,05	5,26	4,67	5,05	5,26
Pdesign +7°C	kW	1,17	1,46	1,65	1,92	3,14	3,15	3,62	3,14	3,15	3,62
Pdesign +12°C	kW	1,43	1,44	1,65	1,65	3,57	3,57	3,34	3,57	3,57	3,34
Annual energy consumption	kWh	2,76	3,3	3,97	4,42	6,87	7,66	8,43	6,87	7,66	8,43

RIELLO

RIELLO S.p.A.
Via Ing. Pilade Riello, 7
37045 Legnago (VR) - Italy
tel. +39 0442 630111
www.riello.com



FAMILY SPRINT



©2023 Carrier. All Rights Reserved.
All trademarks and service marks referred herein
are property of their respective owners.

Riello reserves the right to change the characteristics and data contained in this
document at any time and without prior notice in order to improve its products.
This document therefore cannot be considered as a contract towards third parties

Cod. 27020934 - EN - 04/2023