

AMW ST N

SERIES R32

EN INSTALLATION AND TECHNICAL SERVICE INSTRUCTIONS

RIELLO

Dear Technician,

We would like to congratulate you on having recommended a **RIELLO** unit: a modern product that is capable of ensuring maximum comfort at length, with a high degree of reliability, efficiency, quality and safety.

While your technical skills and knowledge will certainly be more than sufficient, this booklet contains all the information that we have deemed necessary for the device's correct and easy installation.

Thank you again, and keep up the good work.

RIELLO S.p.A.

COMPLIANCE

RIELLO AMW ST N heat pumps are compliant with the following European Directives:

- Low Voltage Directive 2014/35/EU
- Electromagnetic Compatibility Directive 2014/30/EU
- RoHS Directive 2011/65/EU
- ErP Directive 2009/125/EC and Regulation 2012/206/EC
- WEEE Directive 2012/19/EU
- F-Gas Regulation 2014/517/EU



RANGE

Model	Code
AMW ST 25 N	20206307
AMW ST 35 N	20206309
AMW ST 50 N	20206310
AMW ST 70 N	20206311

ACCESSORIES

For the complete list of accessories and the information relating to their usage combinations, please refer to www.riello.it.

TABLE OF CONTENTS

1	GENERAL INFORMATION	<i>p. 4</i>
1.1	General Notices	<i>p. 4</i>
1.2	Safety precautions	<i>p. 4</i>
1.3	Unit description	<i>p. 5</i>
1.4	Safety and adjustment devices	<i>p. 5</i>
1.5	Identification	<i>p. 5</i>
1.6	Layout	<i>p. 5</i>
1.7	Technical specifications	<i>p. 6</i>
1.8	Cooling circuit	<i>p. 6</i>
2	INSTALLATION	<i>p. 7</i>
2.1	Receiving the product	<i>p. 7</i>
2.2	Labels positioning	<i>p. 7</i>
2.3	Dimensions and weight	<i>p. 7</i>
2.4	Storage	<i>p. 8</i>
2.5	Handling and removal of the packing	<i>p. 8</i>
2.6	Place of installation	<i>p. 8</i>
2.7	Recommended distances	<i>p. 9</i>
2.8	Installation on old systems or systems in need of upgrading	<i>p. 9</i>
2.9	Positioning	<i>p. 9</i>
2.10	Condensate discharge position	<i>p. 11</i>
2.11	Refrigerating connection	<i>p. 12</i>
2.12	Condensate discharge connection	<i>p. 14</i>
2.13	Wiring diagram	<i>p. 15</i>
2.14	Electrical connection	<i>p. 16</i>
2.15	Remote control	<i>p. 17</i>
2.16	Unit display	<i>p. 19</i>
3	COMMISSIONING AND MAINTENANCE	<i>p. 20</i>
3.1	Preparation for first commissioning	<i>p. 20</i>
3.2	Putting into service	<i>p. 20</i>
3.3	Temporary shutdown	<i>p. 21</i>
3.4	Stop for an extended period of time	<i>p. 21</i>
3.5	Ordinary maintenance	<i>p. 21</i>
3.6	Extraordinary maintenance	<i>p. 22</i>
3.7	Alarms	<i>p. 22</i>
4	DISPOSAL	<i>p. 24</i>

The following symbols are used on the product:



Avoid proximity to sources of ignition in continuous operation (open flames, gas household appliances, electric stoves, lit cigarettes, etc).



For more information, see the installation and technical service instructions.



Before performing maintenance and service tasks, read the installation and technical service instructions.



Before the installation, read the installation and technical service instructions.

The following symbols are used in this publication:



WARNING = actions requiring special care and appropriate training.



















DO NOT = actions that **MUST ON NO ACCOUNT** be carried out.

This booklet cod. Doc- 0219654 rev. 0 (07/2023) consists of 25 pages.

1 GENERAL INFORMATION









1.1 General Notices

-  When you get the product, check immediately that the contents are all present and undamaged. Contact the dealer **RIELLO** if you notice any problems.
-  The product's installation must be carried out by an authorised company that will issue a declaration of the installation's conformity to the product's owner once the work has been completed, indicating that the work has been carried out in accordance with the standards of good practice, current National and Local regulations, and the indications provided by **RIELLO** in the instruction booklet accompanying the device.
-  The R32 refrigerant gas is slightly inflammable and odourless. Carefully read the safety data sheet available from the dealer and see table "Minimum floor area for wall installation" p. 9.
-  The product must be used for its intended purpose, as stated by **RIELLO** for which it has been expressly manufactured. **RIELLO** shall bear no responsibility, whether of a contractual or non-contractual nature, for any damage caused to people, animals, or property due to incorrect installation, adjustments, or maintenance, or improper use.
-  Suitable clothing, instrumentation, and accident-prevention devices must be utilized during the installation and/or maintenance operations. **RIELLO** shall bear no responsibility for any failure to comply with current safety and accident-prevention regulations.
-  During installation and/or service operations, keep the area around the unit tidy and clean.
-  Comply with the legislation in force on the country of deployment with regard to the use and disposal of packaging, of cleaning and maintenance products and for the management of the unit's decommissioning.
-  Any repair and maintenance interventions must be carried out by **RIELLO** Technical Support Service, in accordance with the provisions contained in this publication. Do not modify or tamper with the unit as dangerous situations may arise and the unit manufacturer will not be liable for any damage caused.
-  In the event of any functional anomalies or fluid leaks, set the system's main switch to its "off" position. Promptly contact your local **RIELLO** Technical Support Service, and do not perform any interventions upon the device on your own.
-  The units contain refrigerant gas: operate carefully so as to avoid damaging the gas circuit and the fin bank.
-  Any gas leaks indoors can generate toxic gases if they come into contact with naked flames or high temperature bodies, in case of leaks, please air the rooms thoroughly.
-  Do not place any inflammable object (spray cans) within a 1 metre radius from the air expulsion.

-  This appliance contains a UVC lamp. Do not operate UVC lamps outside of the appliance. Unintended use of the appliance or damage to the housing may result in the escape of dangerous UV-C radiation. UV-C radiation may, even in small doses, cause harm to the eyes and skin.
-  According to EU Regulation no. 517/2014 regarding certain fluorinated greenhouse gases, the total amount of refrigerant contained within the installed system must be indicated. This information can be found on the unit technical data plate.
-  This unit contains fluorinated greenhouse gases covered by the Kyoto protocol. Maintenance and disposal activities must be carried out exclusively by skilled personnel.
-  This booklet is an integral part of the device, and must therefore be carefully preserved, and must ALWAYS accompany it, even in the event that it is sold to another Owner or User, or is transferred to another system. If it is damaged or lost, another copy can be requested to **RIELLO** Technical Support Service in your Area.

1.2 Safety precautions

It should be noted that the use of products that utilize electric energy requires certain essential safety regulations to be respected, including the following:

-  Do not allow children or unassisted disabled people to use the unit.
-  Do not touch the unit while barefoot and/or partially wet.
-  Do not spray or throw water directly on the unit.
-  It is strictly forbidden to touch the coil fins, the moving parts, to place any body parts between them, or to insert pointy objects into the grilles.
-  It is forbidden to perform any technical interventions or cleaning operations before having disconnected the device from its electrical power supply, by setting the system's main switch to its "OFF" position.
-  It is forbidden to modify the safety or regulation devices without the authorisation of the manufacturer.
-  Do not pull, detach or twist the electrical wires coming out of the unit, even when the unit is disconnected from the power grid.
-  It is forbidden to remove UVC barriers.
-  The packing material must not be disposed of in the surrounding environment and must be kept out of children reach, as it can be dangerous. It must be disposed of according to the regulations in force.

1.3 Unit description

RIELLO AMW ST N is an indoor unit for wall installation, suitable for use in residential and small business premises in combination with the outdoor unit. The multiple-speed fan DC motor improves performance and sound comfort. Control, regulation and programming of the unit are carried out by means of the infra-red remote control, whose functions and use are detailed in the user manual.

1.4 Safety and adjustment devices

The device safety and setting are achieved thanks to:

- heat exchanger temperature sensor transmitting the detected value to the control panel, which is triggered in case of abnormal temperature with regard to the operating mode
- room air temperature sensor transmitting the detected value to the control panel in order to control the operation of the outdoor unit and regulate the room temperature

⚠ Safety device replacement must be carried out by **RIELLO** Technical Support Service, using only original components. Please refer to the spare parts catalogue.

⊖ IT IS FORBIDDEN to operate the device with faulty safety systems.

1.5 Identification

The unit can be identified through the technical data plate:

1.6 Layout

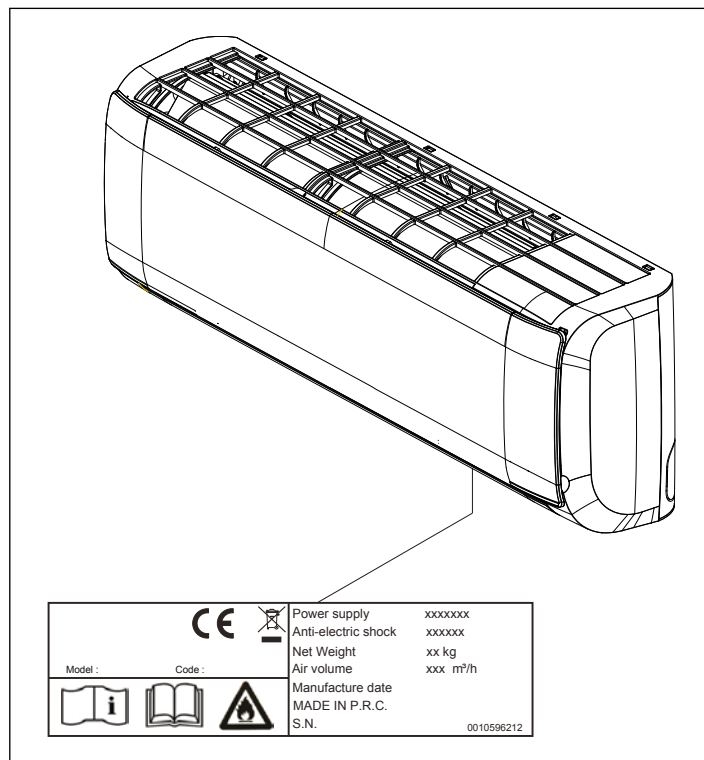

Technical data plate

Contains the device's technical and performance data.

⚠ The tampering, removal, or absence of the identification plates will not allow the product to be properly identified by its serial number.

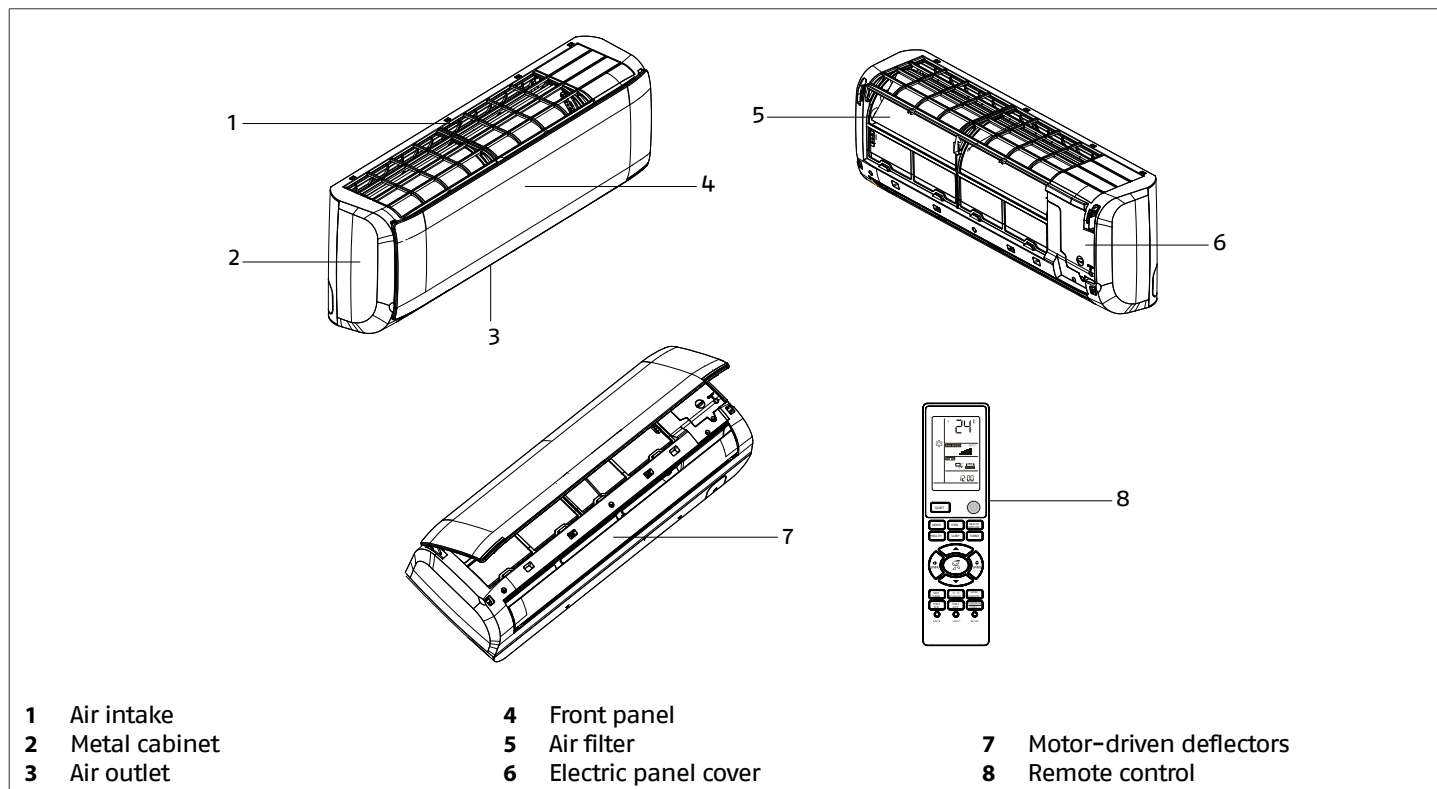

1.7 Technical specifications

Riello model		25 N	35 N	50 N	70 N
Electrical characteristics					
Power supply	V/Ph/Hz	230/1/50			
Protection factor	IP	IPX0			
Fan					
Quantity	no.	1			
Nominal power input	kW	0,04	0,02	0,04	
Nominal current consumption	A	0,10		0,20	
Maximum air flow	m ³ /h	550	600	900	1100
Medium air flow	m ³ /h	400	450	800	1000
Minimum air flow	m ³ /h	350	400	600	850
Superminimum air flow	m ³ /h	250		400	750
Maximum speed	rpm	1150	1200	1100	1250
Medium speed	rpm	1000	1050	950	1075
Minimum speed	rpm	850	900	800	900
Super minimum speed	rpm	650		610	700
Cooling sound levels					
Superminimum sound pressure	dB(A)	18	19	28	29
Minimum sound pressure	dB(A)	28	29	35	37
Medium sound pressure	dB(A)	32	33	40	45
Maximum sound pressure	dB(A)	37		44	47
Maximum sound power	dB(A)	52	54	56	60
Heating sound levels					
Superminimum sound pressure	dB(A)	18	19	28	29
Minimum sound pressure	dB(A)	28	29	35	37
Medium sound pressure	dB(A)	32	33	40	45
Maximum sound pressure	dB(A)	37		44	47
Maximum sound power	dB(A)	52	54	56	60

 Performance data are indicated in the matching outdoor unit manual.

1.8 Cooling circuit

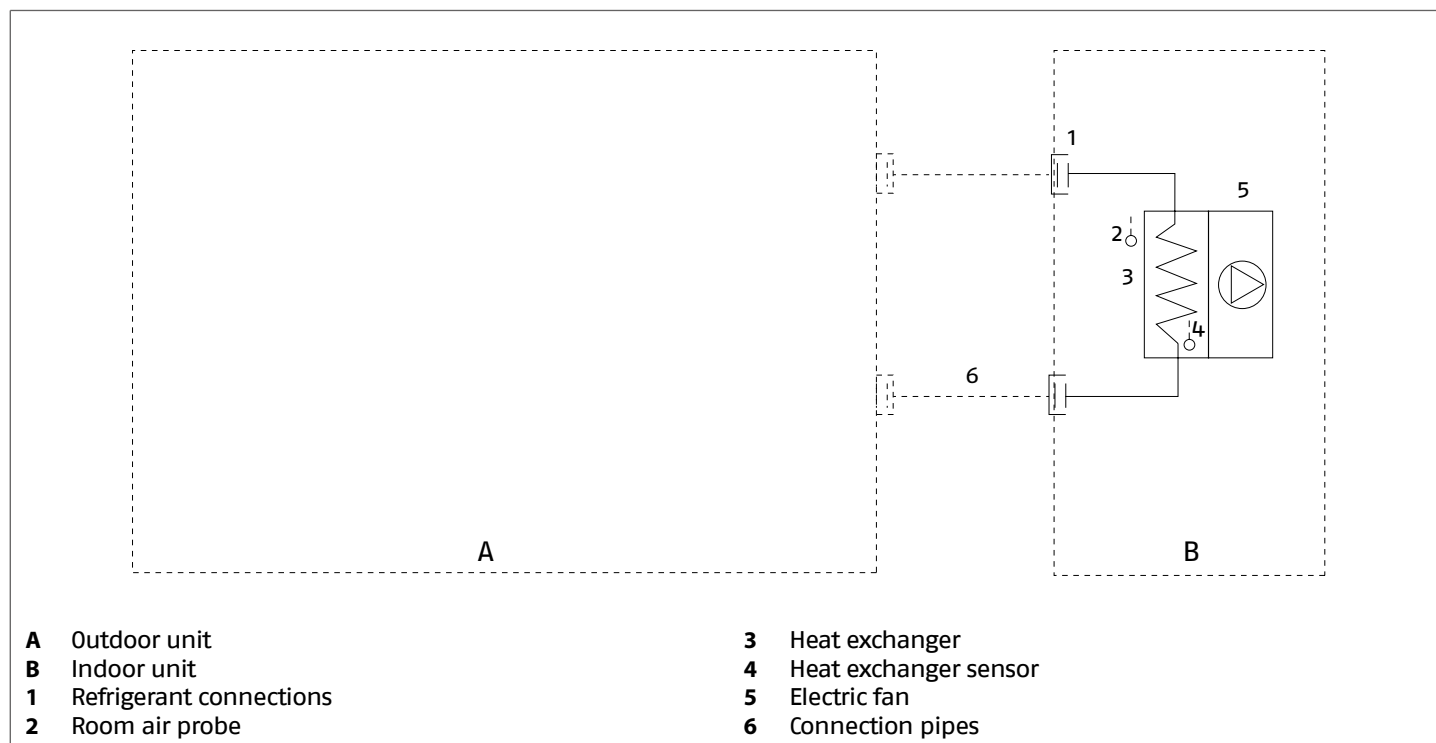

2 INSTALLATION

⚠ Ensure that the installation and operation sites are properly ventilated in order to disperse any gas leaks that could cause flames during activities with intense heat generation and high temperature.

⚠ Avoid proximity to sources of ignition in continuous operation (open flames, gas household appliances, electric stoves, lit cigarettes, etc).

⚠ Use equipment suitable for the system refrigerant.

⚠ Use an electronic leak finder properly calibrated for the system refrigerant.

⊖ It is forbidden to use leak finders with halogen lamps.

2.1 Receiving the product

RIELLO AMW ST N is supplied in a single package, protected by a cardboard packaging, polystyrene elements and a polyethylene film.

The following items can be found inside the packaging:

Document envelope:

- Instruction's book for the installer and for the Technical Service in Italian
- Instruction's book for the installer and for the Technical Service in English
- user instruction booklet in Italian
- user instruction booklet in English
- Warranty/Spare parts labels.
- contact sheets

It is also supplied as kit:

- remote control
- no. 2 AAA batteries
- support for remote control
- no. 2 screws for remote control support
- no. 10 screws and anchor bolts
- flare nut for liquid pipe
- flare nut for gas pipe
- protective insert for gas passageway hole
- condensate discharge pipe

⚠ The Instruction book comes with the equipment and it should be taken, read and kept carefully.

⚠ The document envelope must be kept in a safe place. Any duplicate must be requested from Riello S.p.A. which reserves to charge the cost.

2.2 Labels positioning

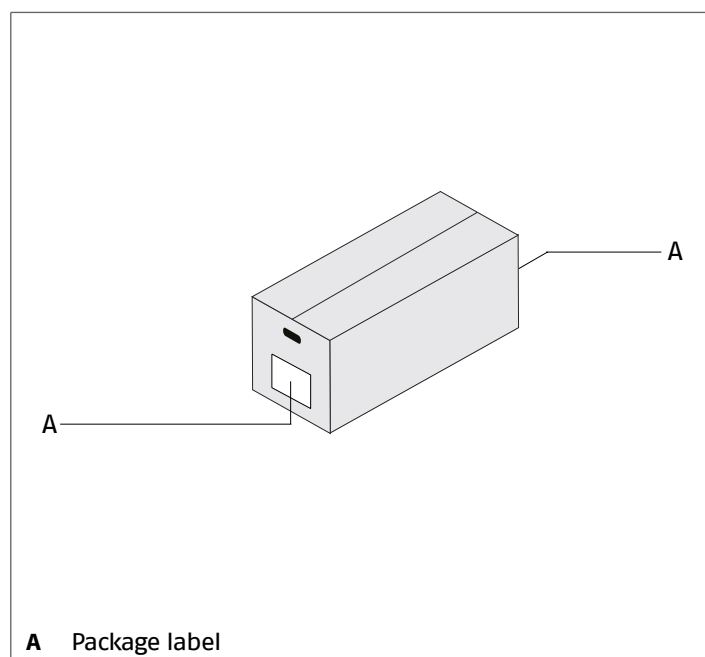

2.3 Dimensions and weight

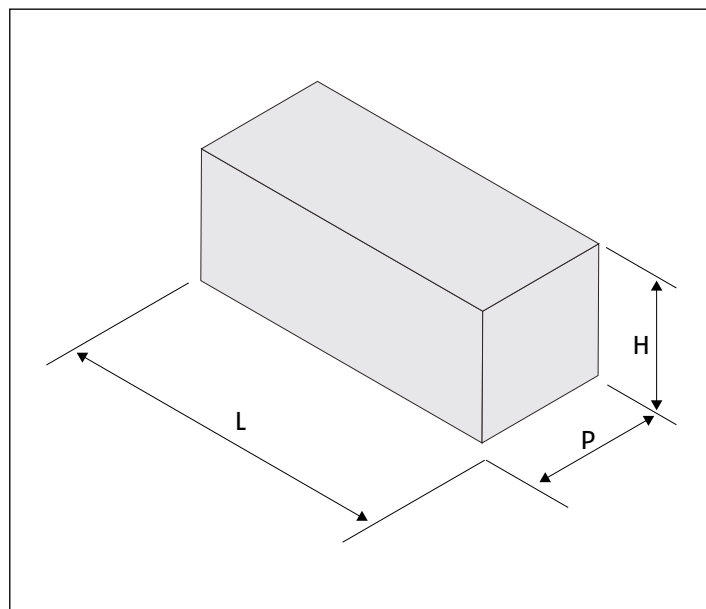

Riello model		25 N	35 N	50 N	70 N
Packaging dimensions					
H	mm	363	363	397	397
L	mm	874	874	1050	1050
P	mm	270	270	301	301
Weight	kg	10,5	10,5	14,4	14,4

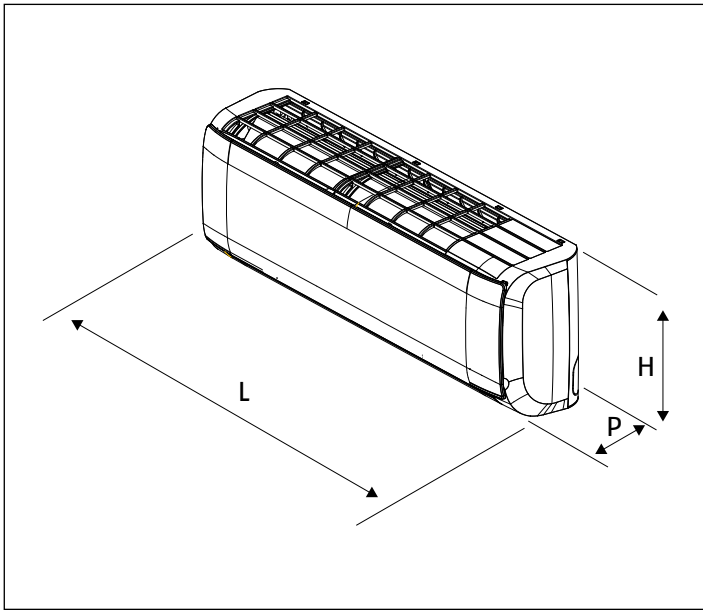

Riello model		25 N	35 N	50 N	70 N
Product dimensions					
H	mm	290	290	320	320
L	mm	805	805	975	975
P	mm	200	200	220	220
Weight	kg	8,3	8,3	11,6	11,6

2.4 Storage

⚠ The product must be stored according to the regulations in force.

2.5 Handling and removal of the packing

⚠ Before unpacking, personal protective clothing should be worn and used transport means and tools suitable for the size and weight of the unit.

The product can be handled manually.

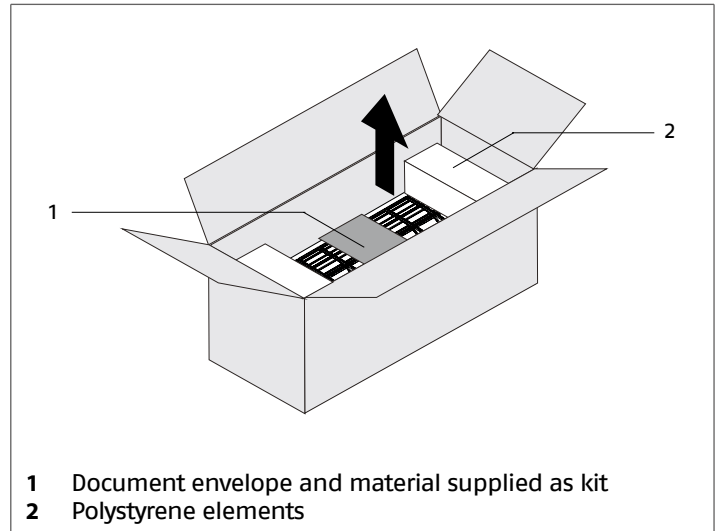
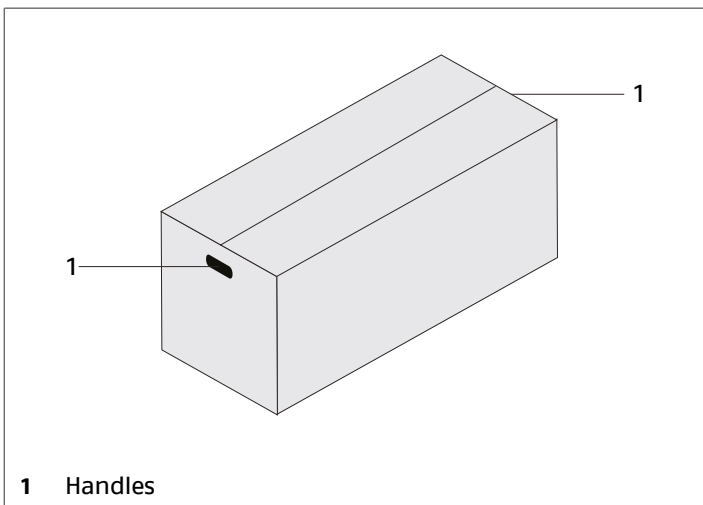

Follow the below instructions for packing removal and product handling:

- transport the equipment in the installation place
- open the cardboard packaging
- remove the document envelope
- take out the device by lifting it up
- remove the polystyrene elements
- remove the polyethylene bag

⚠ In manual operation it is compulsory to respect always the maximum weight per person provided for by the national laws and standards.

⚠ Handle with care

⚠ The packing material must not be disposed of in the surrounding environment and must be kept out of children reach, as it can be dangerous. It must be disposed of according to the regulations in force.

2.6 Place of installation

The location of **RIELLO AMW ST N** devices must be determined by the system's designer or by another competent person, and must take into account the technical requirements, as well as any current local regulations.

⚠ The product uses R32 refrigerant gas and must be installed in rooms with a minimum floor area, as indicated in the following table, depending on the total refrigerant charge of the system (given by the sum of the factory charge of the outdoor unit and, if applicable, the additional charge).

⚠ The amount of refrigerant charged inside the unit refer to the **INSTALLATION AND TECHNICAL SERVICE INSTRUCTIONS** of outdoor unit used.

Minimum floor area for wall installation

mc	A min	mc	A min
kg	m ²	kg	m ²
0,20	No requirements	2,1	4,20
0,60		2,2	4,61
0,80		2,3	5,04
1,0		2,4	5,49
1,10		2,5	5,96
1,22		2,6	6,44
1,225	1,43	2,8	7,47
1,3	1,61	3,0	8,58
1,4	1,87	3,4	11,02
1,5	2,15	3,8	13,77
1,6	2,44	4,2	16,82
1,7	2,76	4,6	20,17
1,8	3,09	5,0	23,83
1,9	3,44	5,4	27,80
2,0	3,81	5,8	32,07

mc: refrigerant charge of the system

A min: minimum floor area for indoor unit

RIELLO AMW ST N is designed for indoor wall installation:

- install the indoor unit in the room to be air-conditioned
- its position must allow for the circulation of treated air in the whole room
- consider an area where there are no obstacles to the regular air delivery and intake

Check that:

- the installation site area is at least 3 sq.m
- the support wall is able to support the device weight
- the wall section does not feature building supporting elements, pipes or power lines
- the supplied wall plugs are suitable for the chosen support wall

Avoid:

- installing the device in hallways or passageways
- any obstacles or barriers that will cause the expelled air to recirculate
- locations with aggressive or explosive atmospheres or with inflammable fluids
- direct exposure to sunlight and proximity to heat sources
- humid locations or positions where the unit could come into contact with water
- environment containing oil vapours
- locations with high frequency contamination

⚠ Avoid placing the unit less than 1 metre away from radio and video systems.

2.7 Recommended distances

The distances for the device installation and maintenance are shown in the figure. The indicated spaces are necessary in order to prevent the airflow from being blocked, as well as to allow normal cleaning and maintenance operations to be carried out.

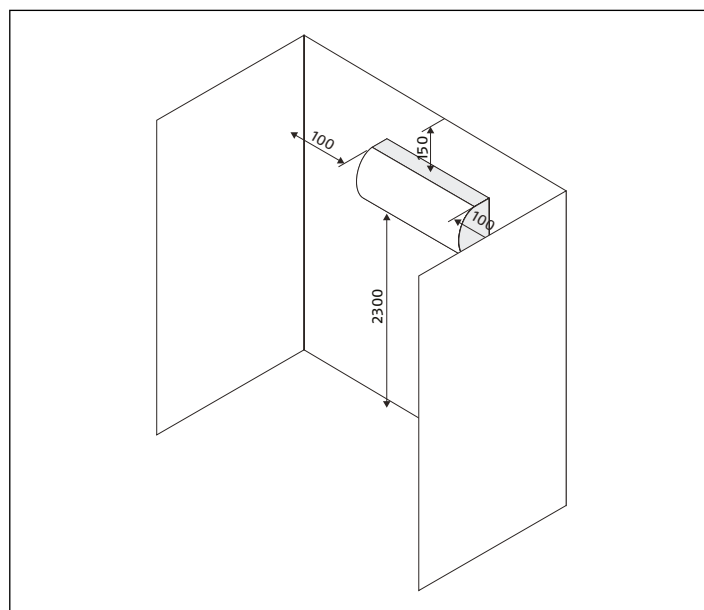

2.8 Installation on old systems or systems in need of upgrading

When **RIELLO AMW ST N** is installed on old systems or systems in need of upgrading, it is recommended to ensure that:

- the electrical system is compliant with the applicable regulations and has been installed by qualified professionals

⚠ In the event of a replacement, the system must be inspected by the designer or by another competent person, and must be compliant with the technical requirements, as well as the current legislations and regulations.

⚠ The manufacturer shall bear no responsibility for any damages caused by incorrect system installation.

2.9 Positioning

RIELLO AMW ST N devices are supplied with a metallic support to fix them to the wall:

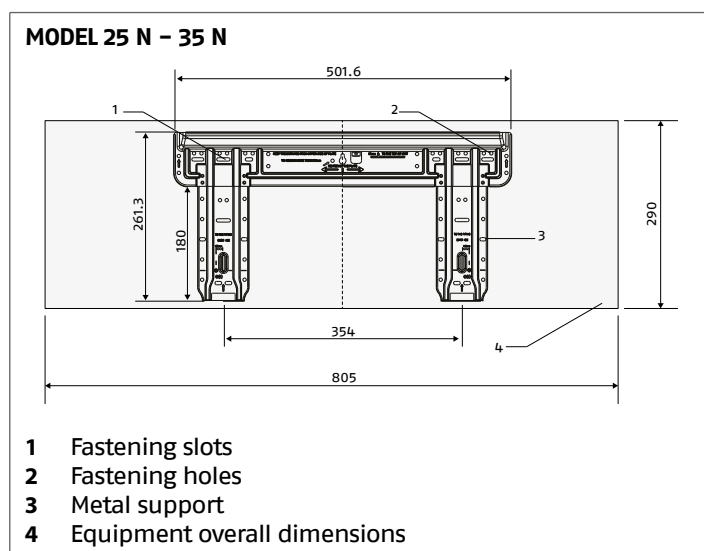

MODEL 50 N - 70 N

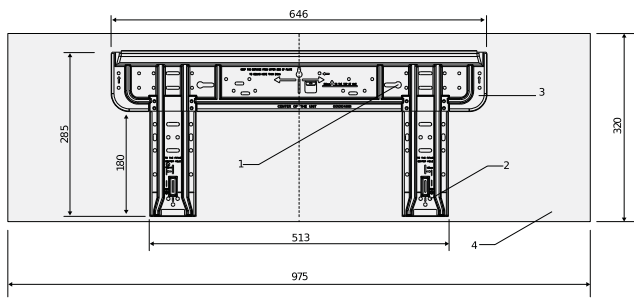

- 1 Fastening slots
- 2 Fastening holes
- 3 Metal support
- 4 Equipment overall dimensions

⚠ Place the metallic support on a level surface that is capable of supporting its weight

Fixing the metallic support to the wall:

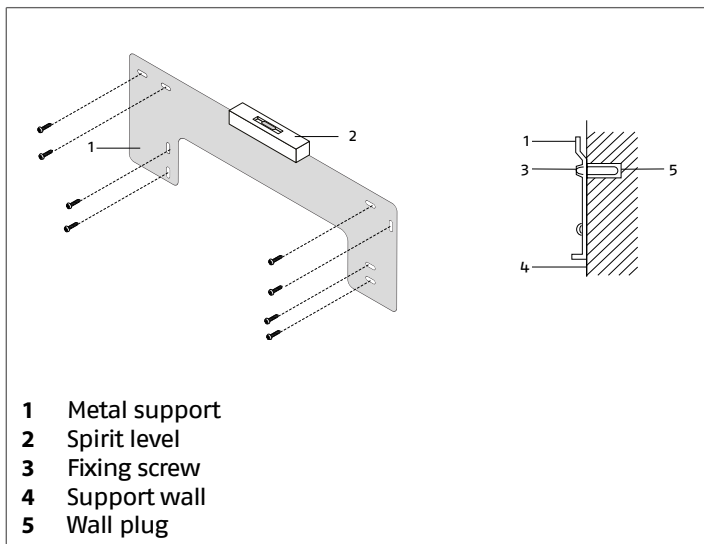

- 1 Metal support
- 2 Spirit level
- 3 Fixing screw
- 4 Support wall
- 5 Wall plug

- remove the metallic support from the unit rear side
- mark the position of the fixing holes using the metallic support as a template
- drill holes in the marked positions
- fix the metallic support with the screws and the wall plugs

⚠ Check that the installation is horizontal using a water level.

Drilling into the wall:

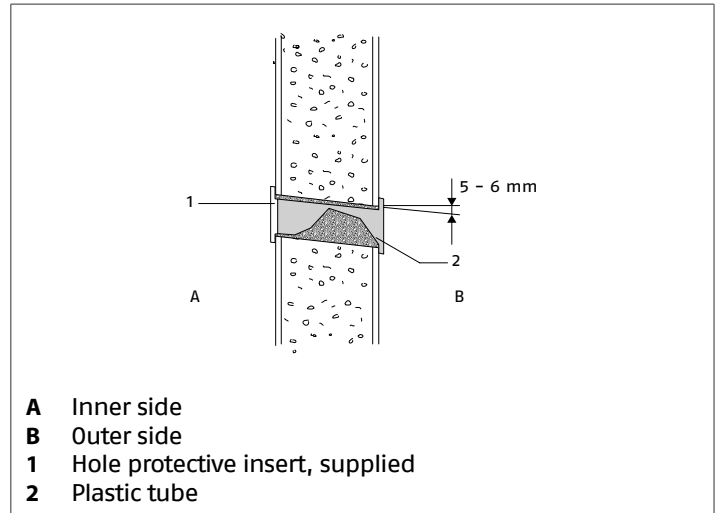

- A** Inner side
- B** Outer side
- 1 Hole protective insert, supplied
- 2 Plastic tube

- drill the through hole into the wall
- keep a downward inclination toward the external side
- insert a plastic tube in the hole in order to protect the connections
- introduce the supplied hole protection insert on the internal side of the wall
- seal with stucco

⚠ In case of connections on the rear side of the unit, refer to chapter "Refrigerating connection" p. 12 for the position of the hole.

Leak test:

The unit is supplied as pre-charged with nitrogen.

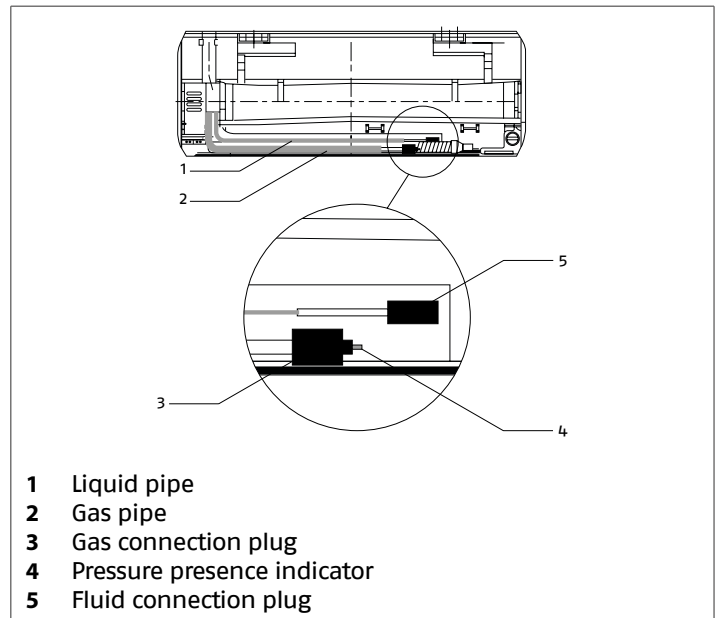

- 1 Liquid pipe
- 2 Gas pipe
- 3 Gas connection plug
- 4 Pressure presence indicator
- 5 Fluid connection plug

- ensure that pressure presence indicator is protruding
- partially loosen one fitting plug
- check for nitrogen leaks to verify that there is pressure inside the device

⚠ If pressure indicator is not protruding, do not continue installation and check for leakage inside the unit.

⚠ Contact **RIELLO** Technical Support Service.

Device preparation:

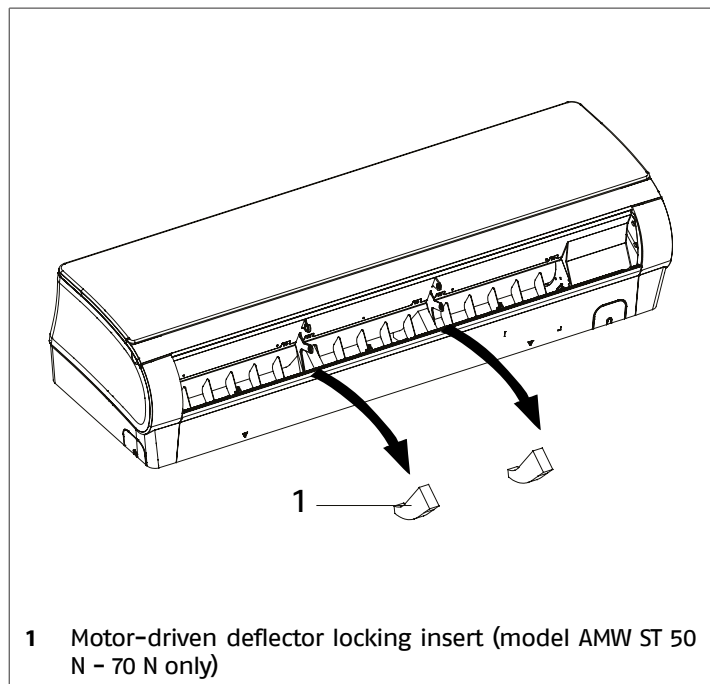

- remove the motor-driven deflector locking inserts

Assembly:

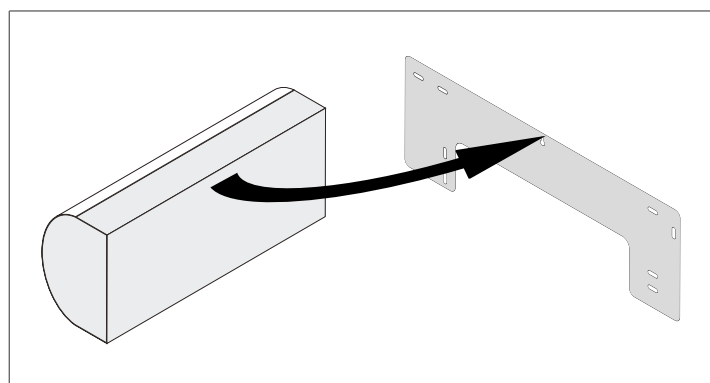

- fasten the unit to the upper part of the metallic support
- check that the unit is correctly hooked by moving it to the left and to the right
- place the unit in the middle of the metallic support

To ease the connections:

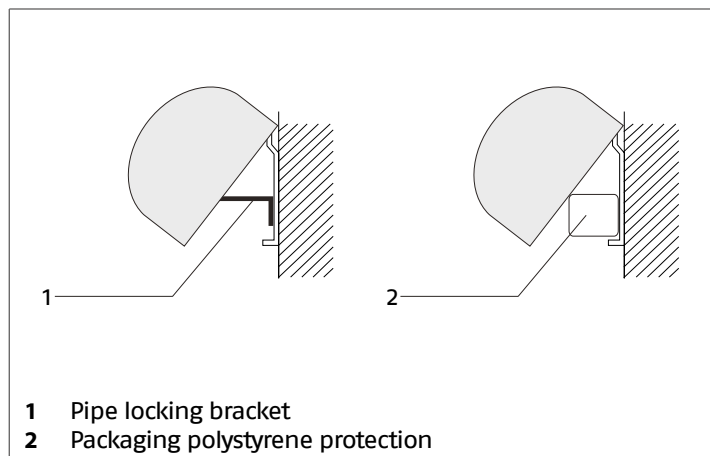

- use the pipe locking bracket to space the unit lower side from the metallic support

If there is a connection box:

- use one of the polystyrene protections from the packaging

After performing the connections:

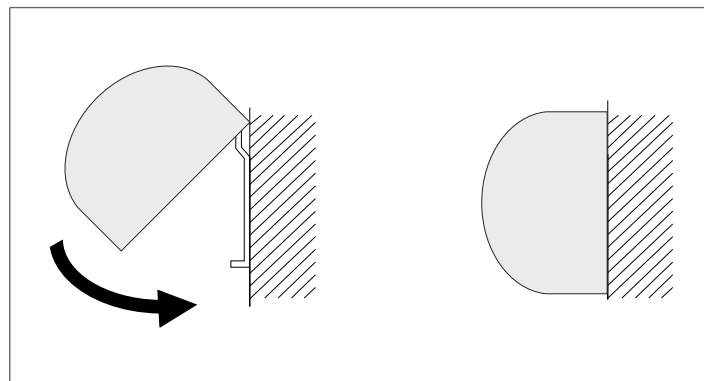

- hook the unit lower part
- by pushing it perpendicularly toward the metallic support

2.10 Condensate discharge position

The hole for the condensate drain is provided as standard on the left side looking back on the unit.

It is possible to move it to the right-hand side. To do so, proceed as follows:

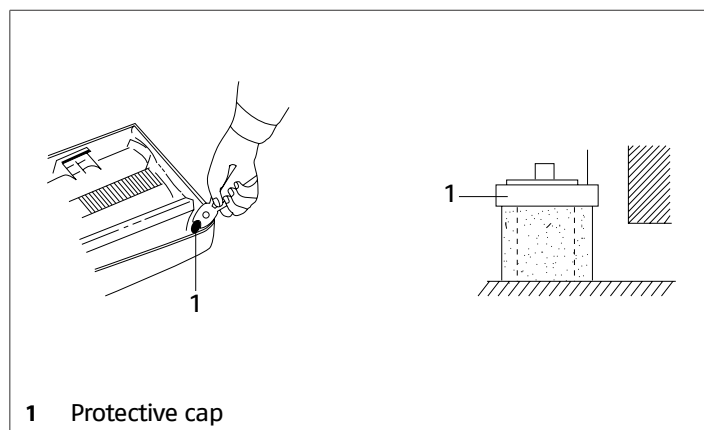

- remove the protection plug from the prearranged connection on the right-hand side

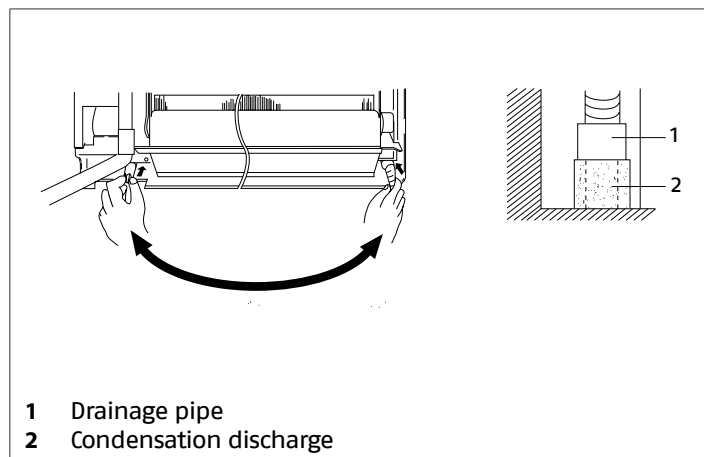

- remove the drainage pipe on the left-hand side and place it on the right-hand side
- fit the protection plug on the spare hole on the left-hand side

2.11 Refrigerating connection

The dimensions and positions of **RIELLO AMWSTN** cooling connections are shown hereunder.

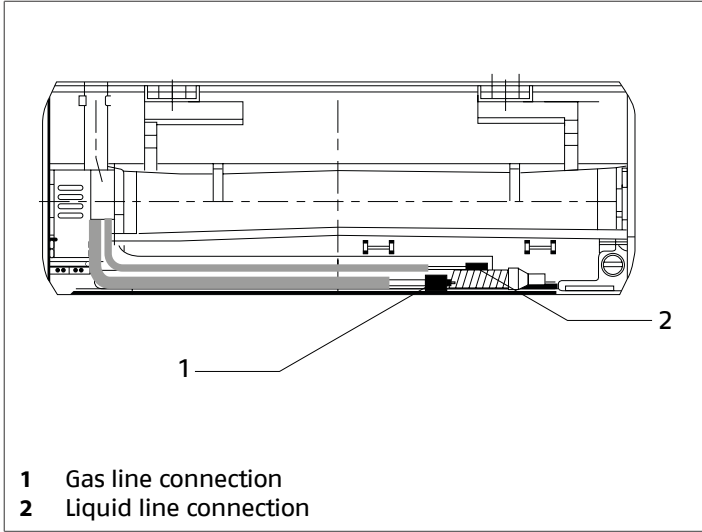

Riello model		25 N	35 N	50 N	70 N
Refrigerant connections					
Liquid line connection	Inches		1/4		
Gas line connection	Inches	3/8		1/2	
Liquid line connection	mm		6,35		
Gas line connection	mm	9,52		12,7	

Connection outlet directions are indicated below.

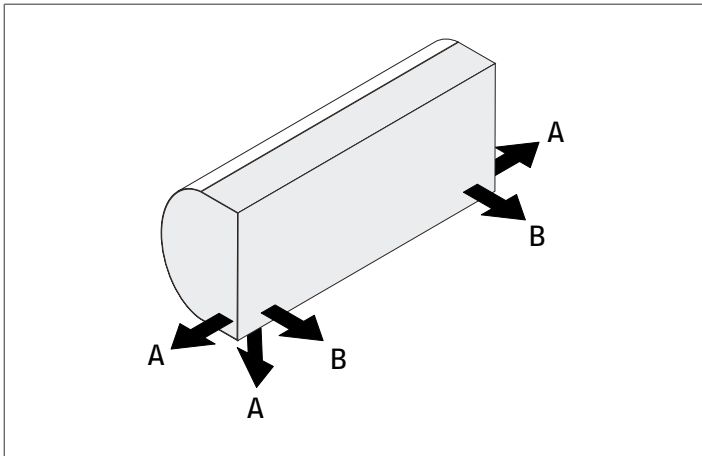

In case of connection in directions A:

- remove the relevant pre-trimmed part on the cover cabinet

In case of connection in directions B:

MODEL 25 N – 35 N

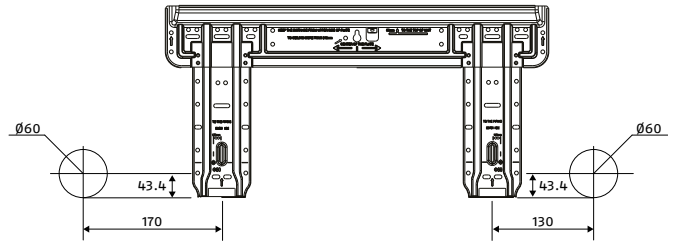

MODEL 50 N – 70 N

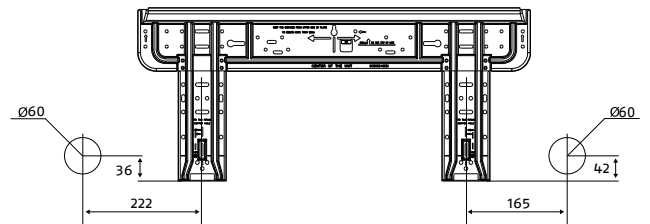

- mark the through hole as shown in the illustration

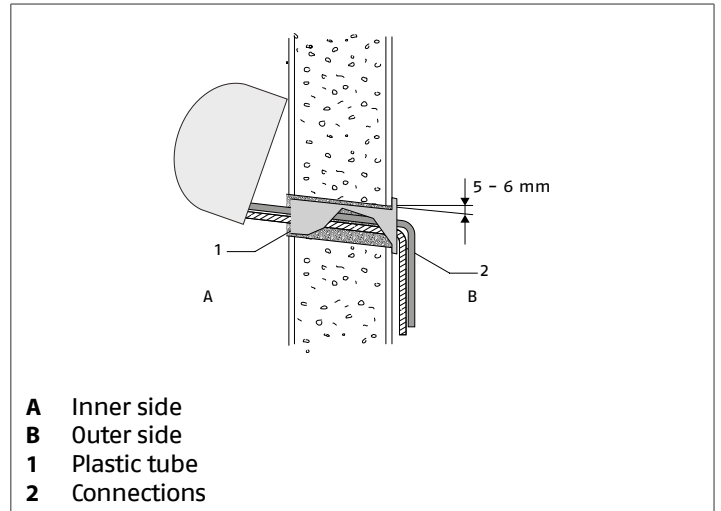

- drill the through hole into the wall
- keep a downward inclination toward the external side
- insert a plastic tube in the hole in order to protect the connections
- introduce the supplied hole protection insert on the internal side of the wall
- seal with stucco

⚠ For indications concerning distances and differences in height of connection pipes, refer to the matching outdoor unit manual.

⚠ Use clean hoses. Make sure the inside is free of dust, residues, water.

- ⚠** Avoid the entry of uncondensable gases (air) in the circuit, otherwise, with the unit in operation, high pressures with the risk of damages might ensue.
- ⚠** Use copper pipes for cooling systems.
- ⊖** It is forbidden to use second-hand cooling lines since their flare connection seal is not guaranteed.
- ⊖** It is forbidden to use pre-charged cooling lines.
- ⊖** It is forbidden to carry out welding operations with refrigerant inside the cooling circuit. If necessary, the refrigerant must be recovered and the circuit must be cleaned with nitrogen without oxygen.

Connections

- position the connecting pipes

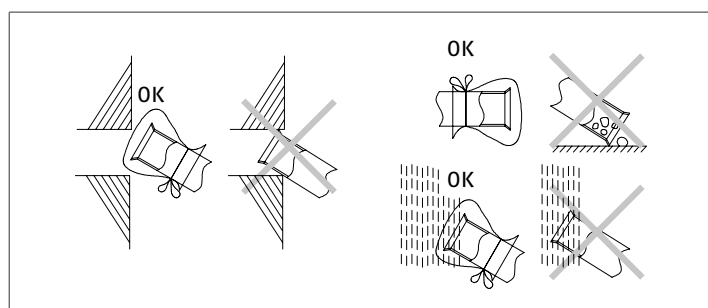

- ⚠** Before threading the lines through the hole in the wall, close the lines ends.

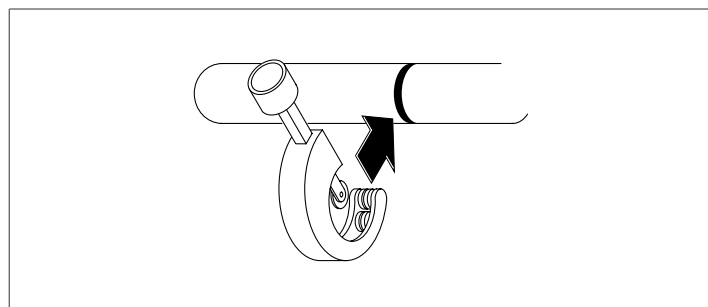

- cut the pipe end square using a pipe cutter
- remove burrs keeping the cut edge facing down
- remove the flare nut on the unit connection
- insert it into the connection pipe
- flare the tube

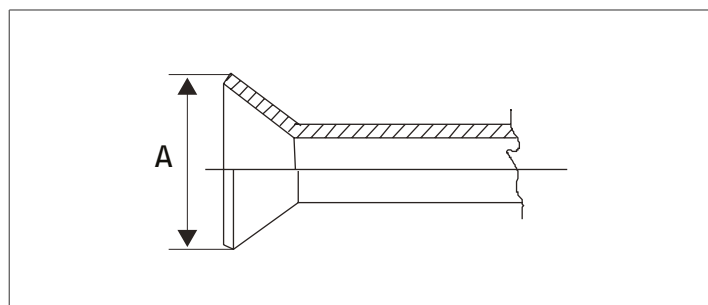

Pipe Ø		A
mm	inches	mm
6,35	1/4	9,1
9,52	3/8	13,2
12,70	1/2	16,6
15,88	5/8	19,7

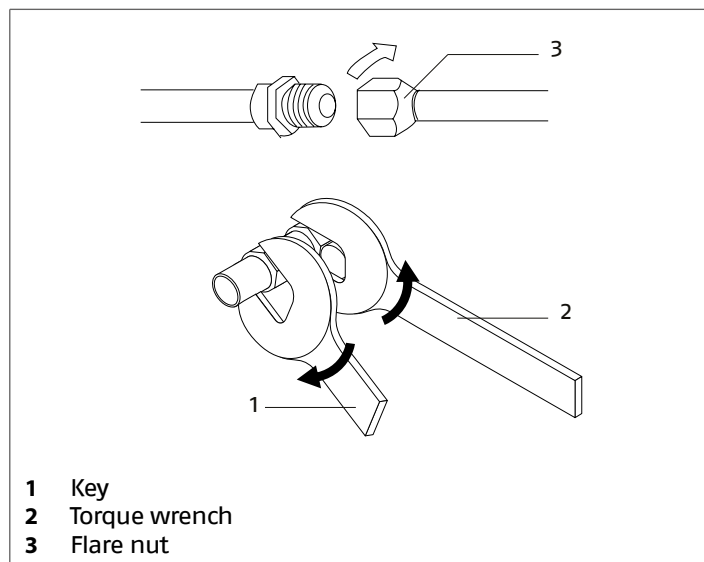

Pipe Ø		Tightening torque
mm	inches	Nm
6,35	1/4	18
9,52	3/8	42
12,70	1/2	55
15,88	5/8	60

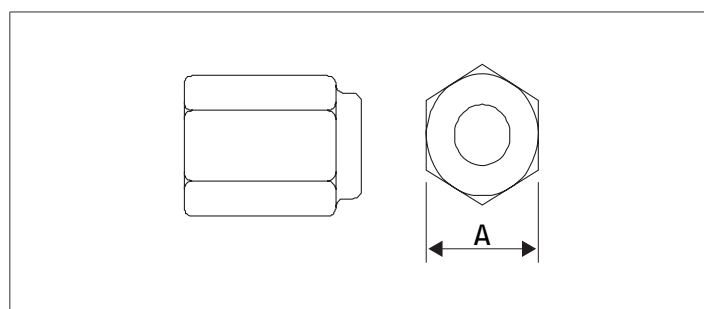

Pipe Ø		A
mm	inches	mm
6,35	1/4	17
9,52	3/8	22
12,70	1/2	26
15,88	5/8	29

- bring line ends with flare connection close to their coupling on the unit
- manually rotate the flare nuts by 3 - 4 turns
- tighten the connections using a spanner and a counter spanner

- ⚠** Use a torque wrench to tighten so as to prevent damage to flare nuts and gas leaks.

- ⚠** Use equipment suitable for the system refrigerant.

INSTALLATION

⚠ During the connection, keep the leak finder on and close to the unit so that it signals any refrigerant leak.

⚠ Avoid using the refrigerant oil on the external part of the flaring.

⚠ Avoid proximity to sources of ignition in continuous operation (open flames, gas household appliances, electric stoves, lit cigarettes, etc).

After connecting the cooling pipes:

- create a vacuum inside the pipes
- check for refrigerant leaks
- apply thermal insulating material on the joints

Pipe insulation

Connection pipes must be thermally insulated to prevent dispersions of heat or formation of condensate.

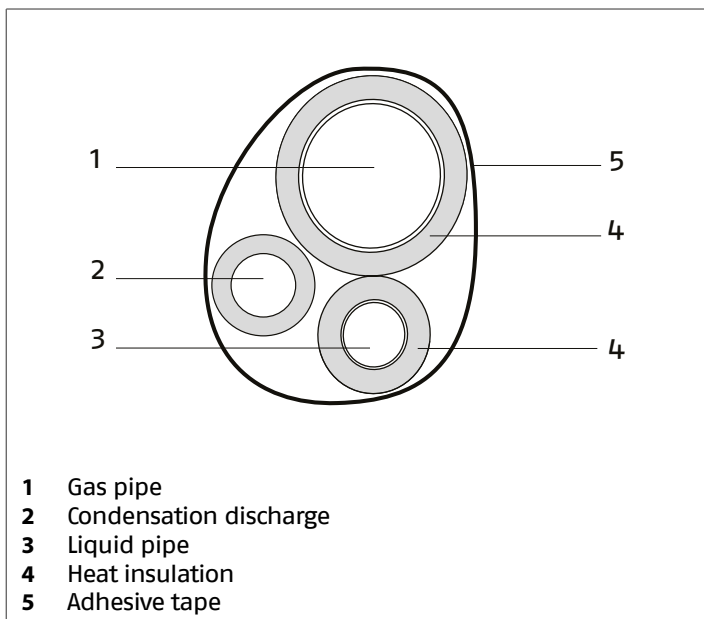

- insulate the liquid and gas pipes separately
- use insulating material that is thicker than 15 mm
- ensure that the insulating material adheres to the pipe without gaps
- fix using adhesive tape

⚠ Do not tighten the adhesive tape too much, so as to avoid damaging the insulation.

⚠ Avoid partial insulation of the pipes.

⚠ In case of use with outdoor temperature above 30 °C and relative humidity above 80%, increase wall thickness up to 20 mm.

For gas pipes:

- ensure that the material used resists to temperatures up to 120°C

For liquid pipes:

- ensure that the material used resists to temperatures up to 70°C

2.12 Condensate discharge connection

RIELLO AMW ST N is provided with a tray that collects condensate generated during the cooling operation, which must be conveyed into a suitable place for discharge. Sizes and position of

the discharge pipe are indicated below.

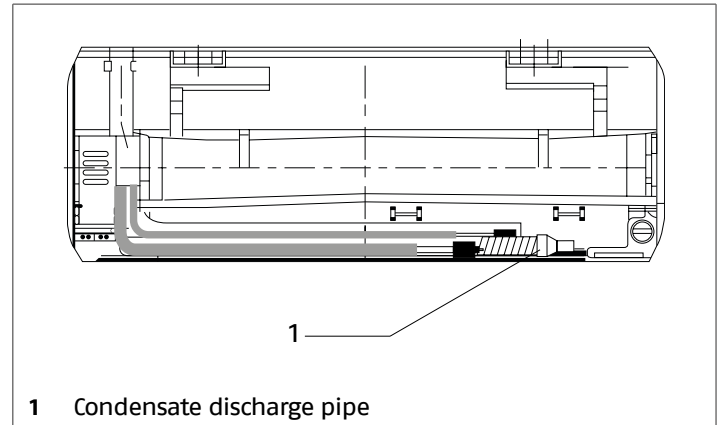

Riello model		25 N	35 N	50 N	70 N
Refrigeration characteristics					
Condensate discharge attachment ∅	mm	16			

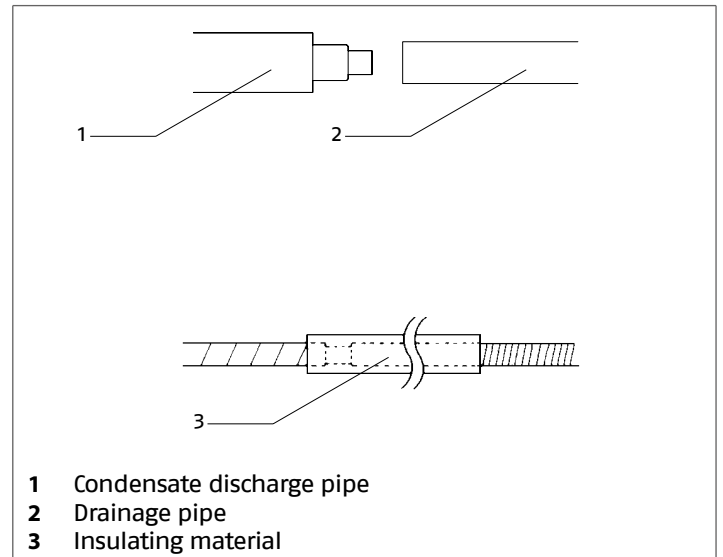

- connect a rubber drainage pipe
- direct it toward a suitable place for discharge
- insulate the joints

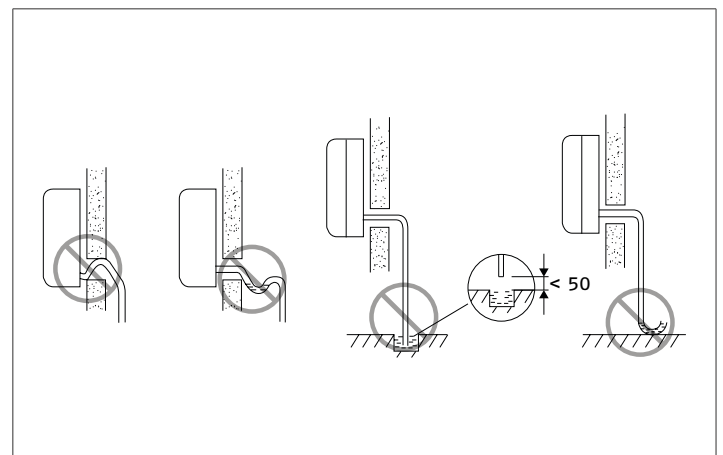

- ⚠** The discharge system must feature a suitable syphon in order to prevent air from entering the vacuum system. The syphon also prevents odours and insects from entering the system.
- ⚠** The syphon must feature a plug in its lower part or must otherwise allow for a quick disassembly for cleaning purposes.
- ⚠** Ensure that all joints are properly sealed so as to prevent water leaks.
- ⚠** The drainage pipe must be insulated for sections running inside houses in order to prevent condensate formation on its surface.

Drainage check:

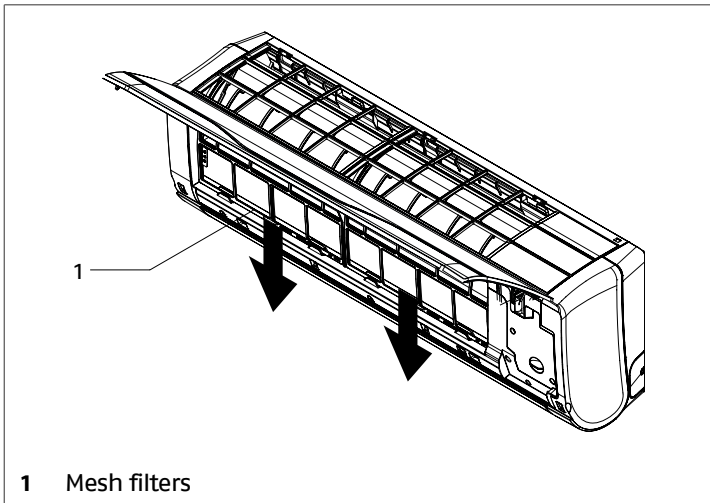

- open the front panel
- take out the mesh filter by grabbing the relevant fins

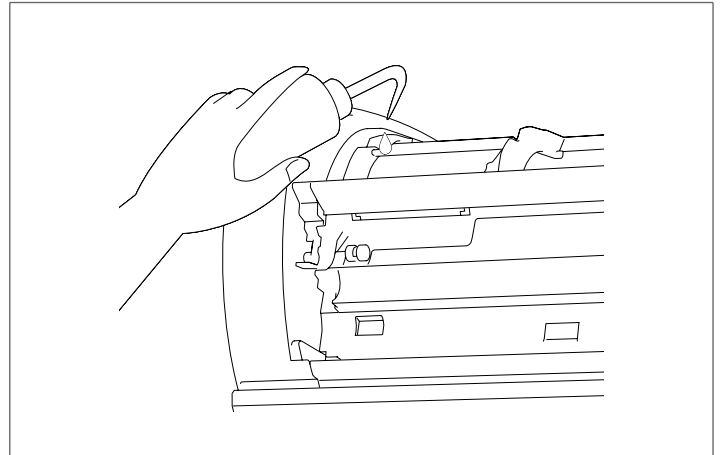

- pour water into the condensate tray
- check that it flows out correctly through the drainage pipe
- reposition the filters
- close the panel

2.13 Wiring diagram

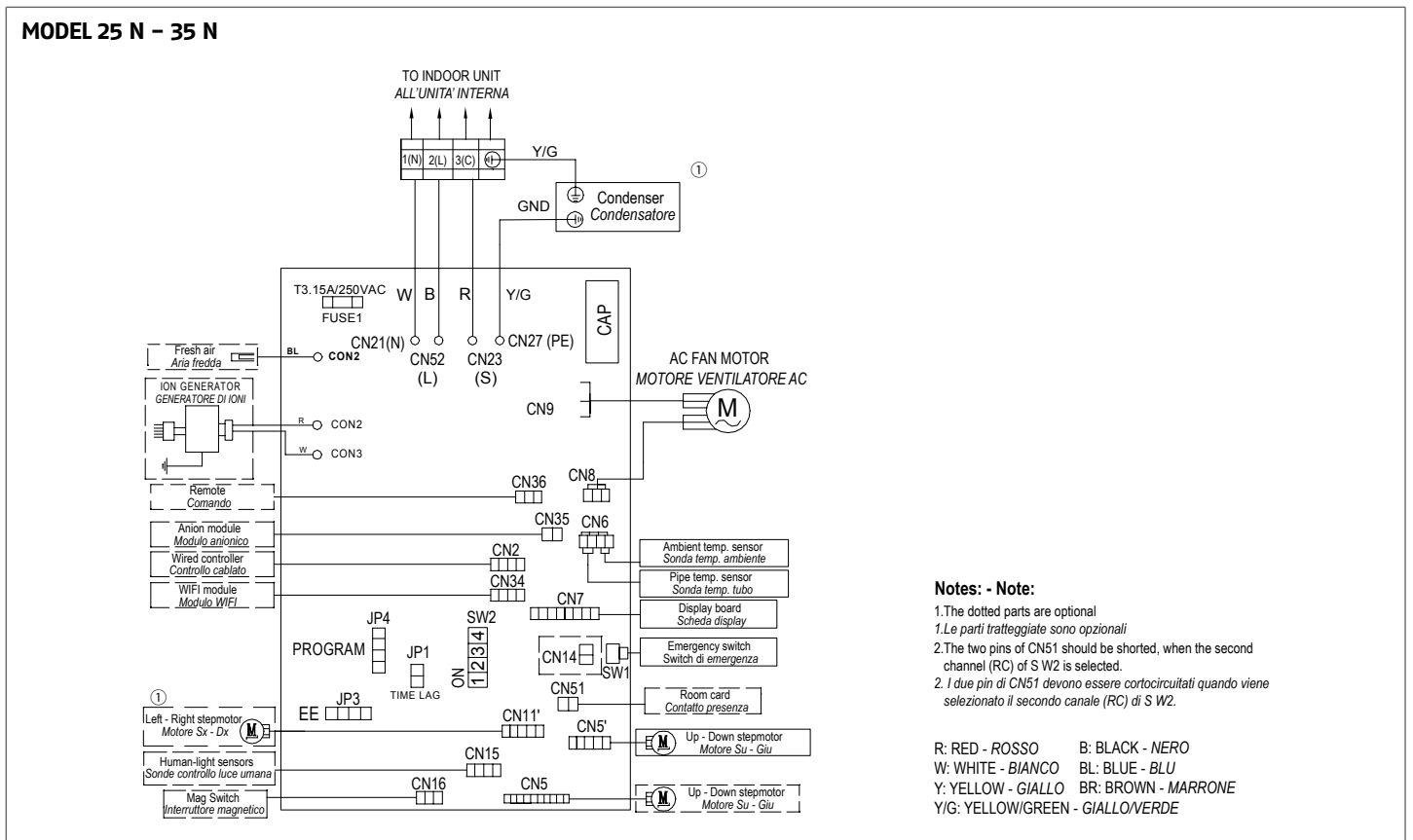

MODEL 50 N - 70 N

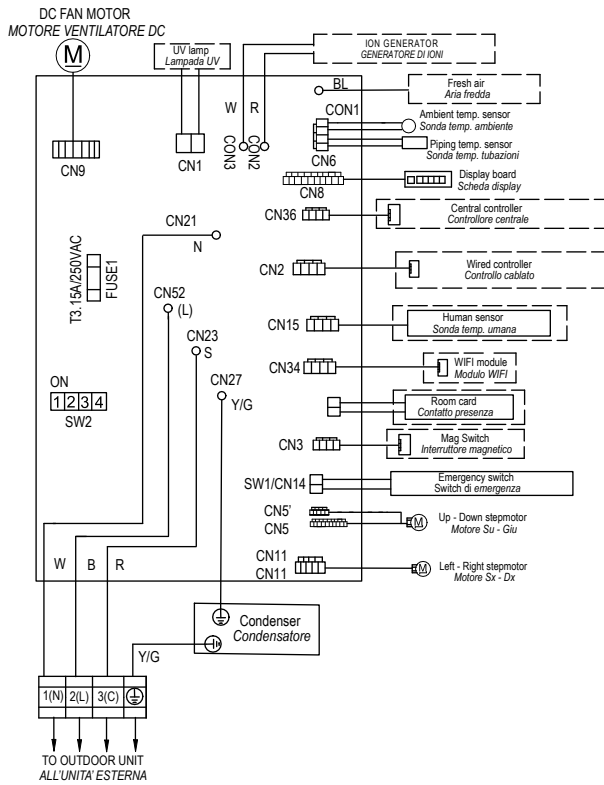

Notes: - Note:

1. The dotted parts are optional
1. Le parti tratteggiate sono opzionali
2. The two pins of CN51 should be shorted, when the second channel (RC) of SW2 is selected.
2. I due pin di CN51 devono essere cortocircuitati quando viene selezionato il secondo canale (RC) di SW2.

R: RED - ROSSO B: BLACK - NERO
 W: WHITE - BIANCO BL: BLUE - BLU
 Y: YELLOW - GIALLO BR: BROWN - MARRONE
 Y/G: YELLOW/GREEN - GIALLO/VERDE

⚠ The dotted parts are optional.

2.14 Electrical connection

AMW ST N it leaves the factory completely wired, and only requires a connection to the outdoor unit.

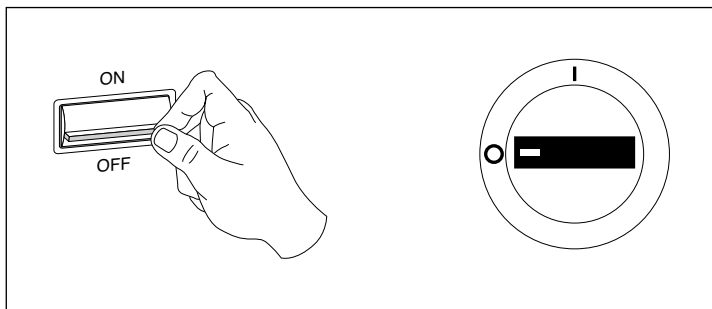

– position the system's main switch in the "OFF" position.
 To access the terminal board:

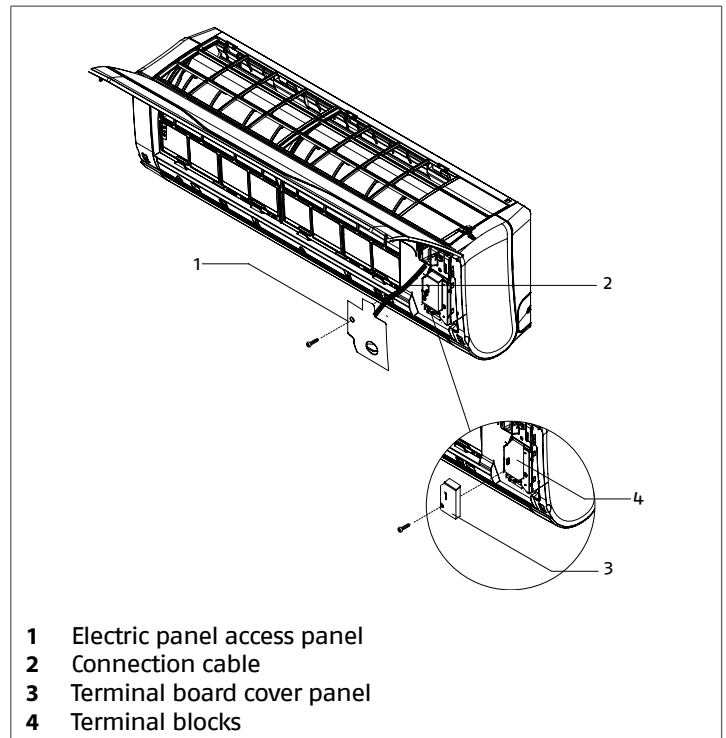

- lift the front panel
- unscrew the fastening screw
- remove the electric panel access panel

⚠ The electric panel access panel is wired to the electronic board, so it must not be completely removed. Pay particular attention not to disconnect or tear off the wire.

- unscrew the fastening screws
- remove the terminal board cover panel

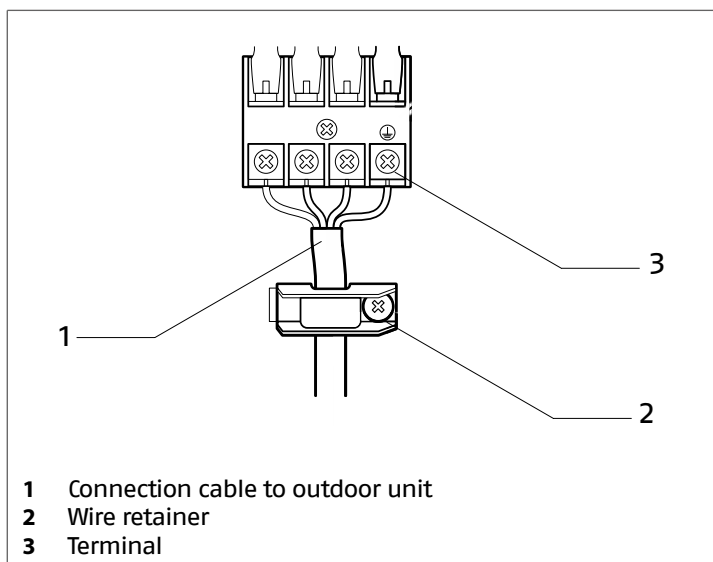

- remove the wire retainer
- make the electric connections according to the diagrams on the installation booklet of the matching outdoor unit

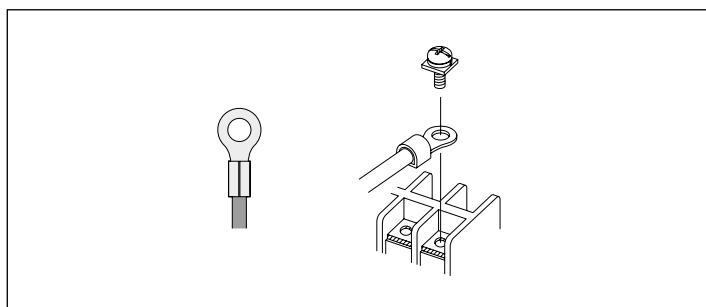

⚠ It is compulsory to use ring crimp terminals to connect to the terminal board.

Refer to the manual of the combined outdoor unit for the sizing of the power supply cable.

- fasten the wires with the wire retainer
- complete the electric connections and refit all components by performing the described operations in reverse order

Mandatory items:

- connect the device to a properly functioning earthing system
- for any electrical intervention, always refer to the wiring diagrams contained within this booklet
- take anti-static precautions in case of weather conditions where humidity is less than 40%

⚠ Electric connections shall be made in compliance with national regulations.

⚠ Avoid placing the connection cables less than 1 metre away from radio and video systems.

⚠ Avoid using mobile phones.

⊖ It is forbidden to earth the device together with pipes, lightning conductors or the earthing system of a telephone line. Using an improper earthing system can cause electric shocks.

2.15 Remote control

Control, setting and programming operations are carried out with the IR remote control.

Based on the temperatures detected by the probes on the indoor unit, the remote control (iFeel) and those on the outdoor unit, the electronics modulates the operation of the unit.

Battery insertion

The remote control is powered by two 1.5V AAA batteries that must be inserted into its rear side and protected by a cover. To insert the batteries:

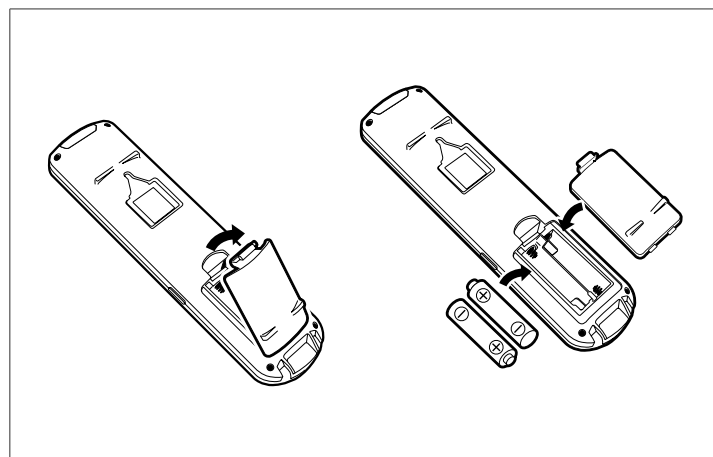







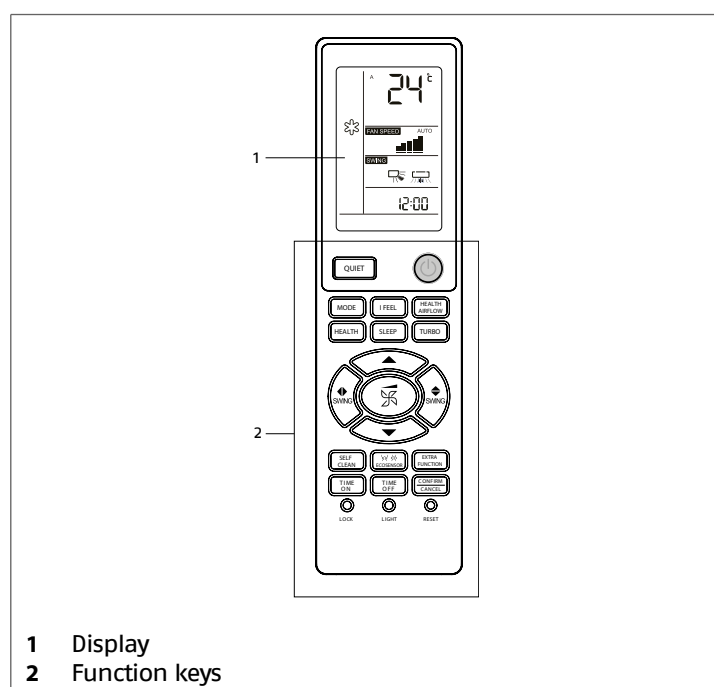











- remove the cover by pressing it down and lifting it up
- insert the batteries respecting the polarities
- put the cover back in place

⚠ Two 1.5V AAA batteries are supplied with the unit for its first set-up.

Function keys



It switches the device on and off

-  QUIET It activates the Quiet mode
-  Select required ventilation speed: minimum, medium, maximum or automatic
-  MODE Enables selection of the different operating modes (Automatic, Cooling, Heating, Dehumidification, Ventilation)
-  I FEEL Activates the IFeel function
-  HEALTH AIRFLOW It enables the Health Air Flow function
-  HEALTH Function not available
-  SLEEP It activates the Sleep function
-  TURBO It enables the Maximum Power function
-  It increases or decreases the selected parameter value
-  Function not available
-  SWING Function not available
-  SWING It activates and deactivates the automatic movement of the horizontal deflector or stops it in a specific position
-  SELF CLEAN Activates the Automatic Cleaning function
-  ECOSENSOR Function not available
-  EXTRA FUNCTION Allows modification of the A-B transmission channel of the remote control, modification of the temperature unit scale between Celsius and Fahrenheit and activates the 10°C function in Heating
-  TIME ON Allows access to the Power-On Timer settings
-  TIME OFF Allows access to the Off timer settings
-  CONFIRM/CANCEL Confirms/deletes settings made
- LOCK Allows the buttons on the remote control to be locked
- LIGHT Allows the display to be illuminated
- RESET Allows the time to be updated

Remote control display



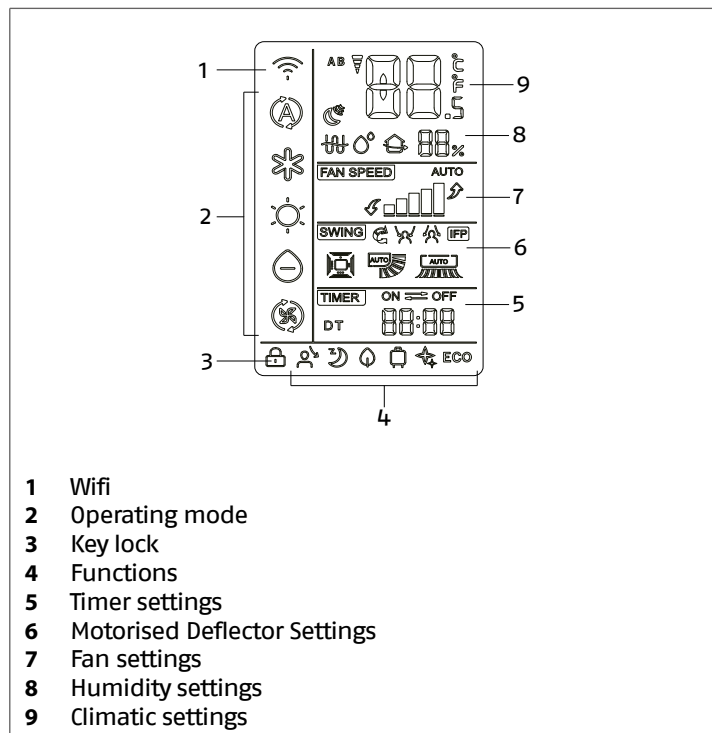

The remote control display shows the settings as changed by the user and the detected weather conditions. The display is divided into uniform areas according to function type.



WiFi (optional)

-  Wifi connection enabled



Operating mode

-  Auto mode active
-  Cooling mode enabled
-  Heating mode enabled
-  Dehumidification mode enabled
-  Ventilation mode enabled

Key lock

-  Remote control keys locked

Functions

-  I FEEL function active
-  Sleep function enabled
-  Health function active

Timer settings



- 88:88 Timer setting value or current time display
- ON Switch on timer enabled
- OFF Switch off timer enabled

Motor-driven deflector settings



-  Horizontal deflector position

-  Function not available
- AUTO Deflector automatic operation

Fan settings

-  Fan speed set
- AUTO Automatic speed enabled
-  Silent function active
-  Maximum active power function

Climatic settings

- 26 °C 1. Detected ambient temperature
2. Desired temperature value when pressing the button 
-  Signal transmission upon pressing the keys

2.16 Unit display

The unit display shows the active functioning mode, the temperature and the alarms, if any.

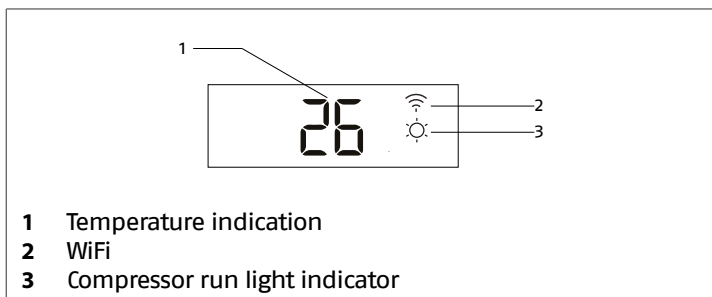
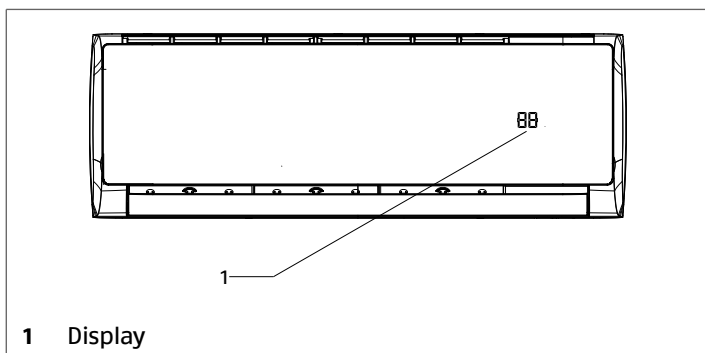

- 26 °C 1. Detected ambient temperature
2. Desired temperature value when the button is pressed 
3. Alarm code

3 COMMISSIONING AND MAINTENANCE

3.1 Preparation for first commissioning

Prior to commissioning, it is necessary to check that:

- all the safety conditions have been met
- all distances have been respected
- the electrical connections have been properly completed
- power supply values are correct.
- the earthing has been carried out correctly
- all the connections have been properly tightened

Microswitch setting

On the main electronic board there are microswitches to manage some functions.

Factory settings

Model	SW2			
	1	2	3	4
25 N	OFF	ON	OFF	OFF
35 N	OFF	ON	OFF	ON
50 N	OFF	ON	OFF	OFF
70 N	OFF	ON	OFF	ON

SW2_1

It selects the transmission channel between the unit and the remote control.

Selectable options are:

OFF = channel "A" (factory setting)

ON = channel "b"

⚠ The channel must be the same for the unit and the remote control.

⚠ Do not change such setting to prevent communication interruptions with the remote control.

SW2_2

It enables and disables the roomcard function:

ON = enabled (factory setting).

- if contact CN51 is open, the unit switches off and cannot be activated via external control
- if contact CN51 is closed, the unit can be activated via external control

OFF = disabled.

- if contact CN51 is open, the unit switches off, but it can be activated via external control
- if contact CN51 is closed, the unit activates automatically

⚠ Contact CN51 is bridged by factory default.

SW2_3 e SW2_4

⚠ Do not change factory setting

Time setting

The current time must be set before using the remote control:

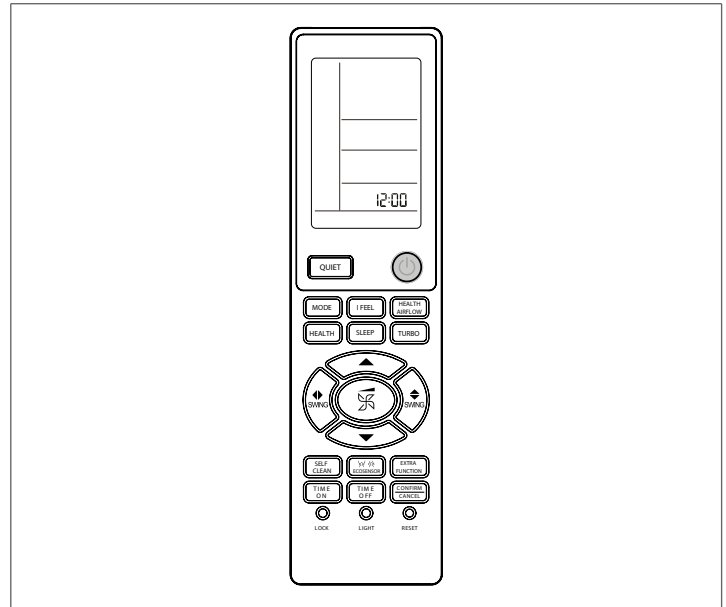

- press the RESET button
- wait 5 seconds

The time indication starts to blink.

- act
- select the current time

Each time the key is pressed, the values changes by 1. By keeping the key pressed down, the value changes faster.

- confirm with

The time indication stops blinking.

3.2 Putting into service

After having completed all the operations required to prepare for first commissioning, do the following to activate the device:

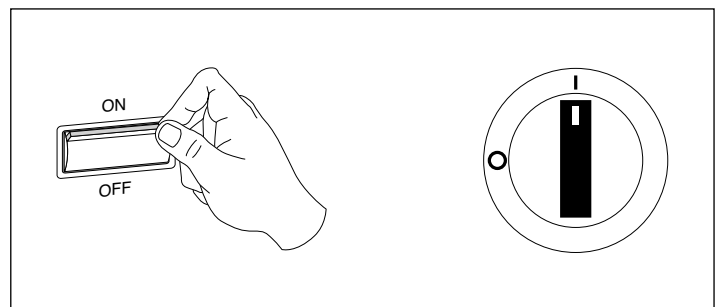

- position the system's main switch in the "ON" position.
- activate the unit with the remote control
- check its operation in the different modes

⚠ The compressor activates 3 minutes after unit activation.

⚠ Refer to the user booklet as for the use of the remote control.

Start-up in cooling mode with low temperatures

When the room temperature is lower than 16°C, the unit does not start in cooling mode. In case you need to check the unit operation in these conditions, you can use the emergency switch.

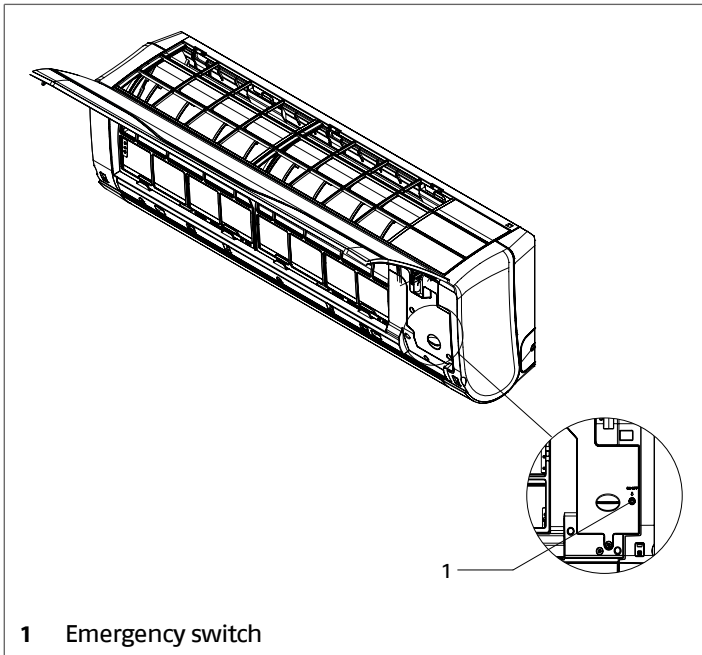

To switch on:

- keep the emergency switch pressed down with a pointy object until a double acoustic signal is emitted
- the air-conditioner starts in cooling mode with high ventilation speed and active air deflector

To switch off:

- press the emergency switch again

⚠ This operation must be carried out in specific conditions and not for usual operation.

Checks during and after the first commissioning

After starting the unit, leave it running for 30 minutes and then check that:

- the working pressures are correct
- the air temperature difference between intake and supply air in the indoor unit is correct
- the current consumed by the compressor is less than the maximum permitted
- the device is operating under the recommended operating conditions
- the unit is able to stop and start up again

⚠ Should any of the above-listed controls have problems: turn the device off and call the Technical Service immediately.

⚠ Do not touch the device pipes to prevent potential burns.

⚠ Take anti-static precautions in case of weather conditions where humidity is less than 40%.

⚠ Avoid using mobile phones.

3.3 Temporary shutdown

In order to shut down the unit for periods of brief absences:

- only use the remote control to disable the unit

3.4 Stop for an extended period of time

If the device has not been used for an extended period of time, carry out the following operations:

- start the device in ventilation mode
- select the maximum speed
- let the device run for 6 hours
- deactivate the unit with the remote control

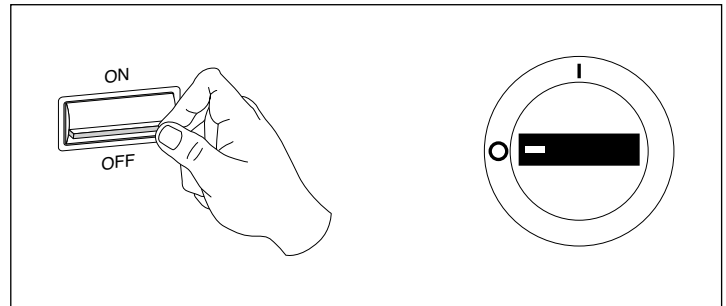

- position the system's main switch in the "OFF" position.

3.5 Ordinary maintenance

Routine maintenance is fundamental for keeping the equipment efficient, safe and reliable. It can be performed periodically by the Technical Support Service, whose staff is technically qualified and can use genuine spare parts, if necessary.

⚠ Original conditions must be restored after performing the required maintenance operations.

⚠ All described operations MUST be carried out under the following conditions:

- cold device
- device NOT supplied with electric power
- suitable personal protection equipment

⊖ Do not open the access covers and carry out technical or cleaning activities before disconnecting the unit from the power grid by positioning the system's main switch in the "OFF" position

Bi-weekly operations

The bi-weekly maintenance schedule includes the following checks:

- cleaning the housing and front panel
- mesh filter cleaning

Cleaning the housing and front panel

- wet a sponge or soft cloth with water and soap to wash
- once cleaning is over dry surfaces with care

⚠ Do not use water at a temperature that is higher than 40°C, powder or abrasive detergents, solvents and brushes.

Yearly operations

The annual maintenance plan includes the following checks:

- power supply voltage
- electric connection tightening
- status of cooling and hydraulic joint
- condensate tray cleaning
- electric absorption

3.6 Extraordinary maintenance

Removal

In case of replacement or extraordinary reparations, you may need to remove the unit.

Proceed as follows to remove the capacitors:

- carry out the evaporator emptying operation

⚠ The operation is detailed in the Installer booklet of the matching outdoor unit.

- deactivate the unit with the remote control
- position the system's main switch in the "OFF" position.
- disconnect the cooling pipes
- disconnect the condensate discharge
- disconnect the electric connections

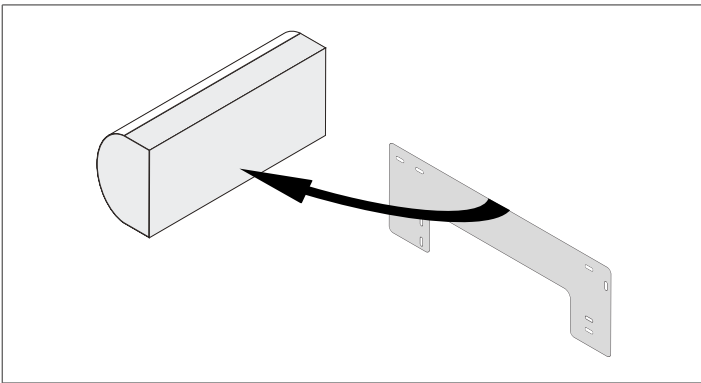
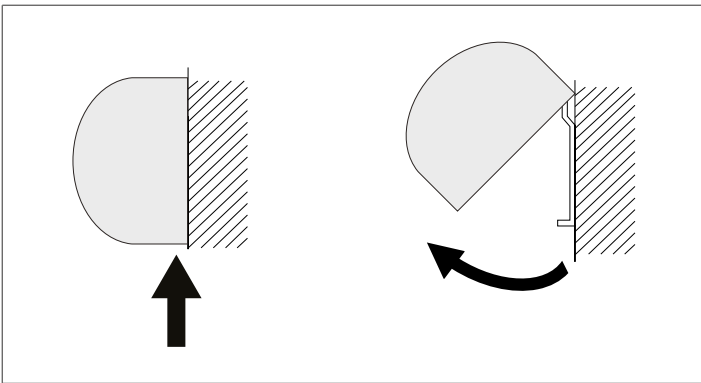

- push up and release the unit from its metallic support
- lift up the unit to remove it

3.7 Alarms

In the presence of operating abnormalities, the unit is secured and blocked.

⚠ Safety block can occur randomly.

⚠ Wait for at least 10 minutes before restarting the unit.

⚠ If the fault occurs again, an accurate check of the device components is required. Contact **RIELLO** Technical Support Service.

Faults are identified by a code on the unit display.

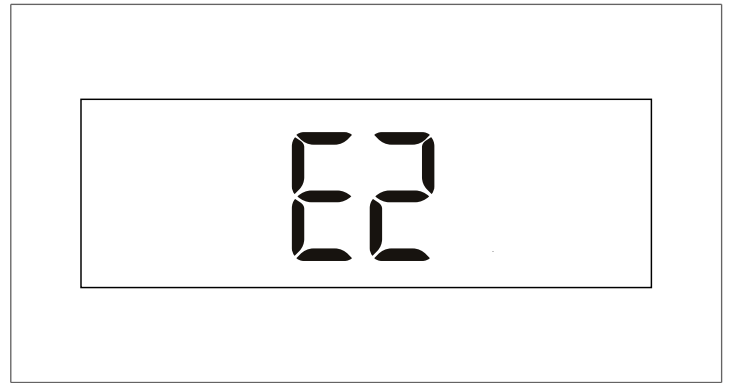

Indoor unit faults

Code	Description	Remarks
E1	Room probe fault	The unit resets after problem resolution
E2	Exchanger probe fault	
E4	Microprocessor malfunction	
E7	Communication error between indoor unit and outdoor unit	
E14	Fan motor malfunction	

Outdoor unit faults

Indoor code indication	Outdoor unit led 1 flashing	Description	Remarks
F1	2	Power module fault	After 3 consecutive interventions in 10 minutes, the unit resets after problem resolution
F2	24	Compressor motor overcurrent	The unit resets automatically
F3	4	Communication error between main board and power module	The alarm activates 4 minutes after the unit start The unit resets after problem resolution
F4	8	Overheat protection for compressor discharge	The unit resets automatically when the temperature drops under 110°C After 3 consecutive interventions in 30 minutes, the unit resets after problem resolution
F6	12	External air probe fault	The unit resets after problem resolution
F7	11	Suction probe fault	The unit resets automatically after the issue has been resolved
F8	9	Fan motor malfunction	After 3 consecutive interventions in 30 minutes, the unit resets after problem resolution
F11	18	Deviate from the normal for the compressor	The unit resets after problem resolution
F12	1	External unit microprocessor fault	The unit resets after problem resolution
F13	16	Lack of refrigerant	The alarm activates 5 minutes after the unit start After 2 consecutive interventions in 20 minutes, the unit resets after problem resolution
F14	17	4-way valve malfunction	The alarm activates 5 minutes after the unit start Alarm and stop if detect $T_m \leq 0$ last for 1min after compressor has started for 10 min in heating mode The alarm is confirmed if it appears 3 times within one hour
F15	20	Electronic board overtemperature protection sensor fault	After 3 consecutive interventions in 1 hour, the unit resets after problem resolution
F19	6	Wrong power supply voltage	The unit resets after problem resolution
F20	5	High pressure protection	The unit resets after problem resolution
F21	10	Pipe probe failure	The unit resets after problem resolution
F22	3	Main electronic board protection against overcurrent	After 3 consecutive interventions in 30 minutes, the unit resets after problem resolution
F23	25	Overcurrent protection for single- phase of the compressor	The unit resets after problem resolution
F25	13	Discharge temperature sensor failure	The alarm activates 4 minutes after the unit start After 3 consecutive interventions in 30 minutes, the unit resets after problem resolution
F27	7	Compressor lockout	After 3 consecutive interventions in 10 minutes, the unit resets after problem resolution
F28	19	Power module malfunction	After 3 consecutive interventions in 10 minutes, the unit resets after problem resolution

4 DISPOSAL

Packaging materials shall be disposed of separately so as to recover and recycle them. At the end of its service life, the device shall be disposed of according to the existing legislation.

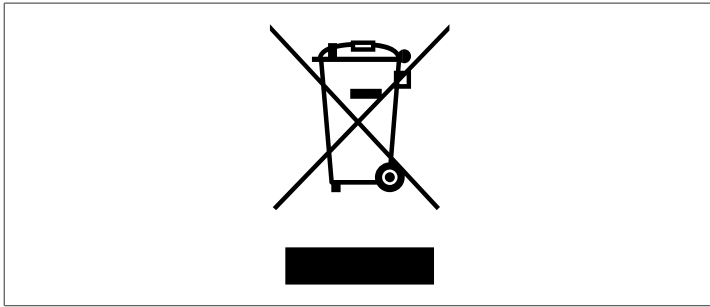

RIELLO

RIELLO S.p.A. - 37045 Legnago (VR)
tel. +39 0442 630111 - fax +39 0442 630371
www.riello.it

As the manufacturer is constantly improving its products, the aesthetic or dimensional features, the technical data, the equipment and accessories indicated could be subject to variations.