

# AARIA START N

SERIES R32

EN INSTALLATION AND TECHNICAL SERVICE INSTRUCTIONS

# RIELLO

Dear Technician,

We would like to congratulate you on having recommended a **RIELLO** unit: a modern product that is capable of ensuring maximum comfort at length, with a high degree of reliability, efficiency, quality and safety.

While your technical skills and knowledge will certainly be more than sufficient, this booklet contains all the information that we have deemed necessary for the device's correct and easy installation.

Thank you again, and keep up the good work.

RIELLO S.p.A.

## COMPLIANCE

---

**RIELLO AARIA START N heat pumps are compliant** with the following European Directives:

- Low Voltage Directive 2014/35/EU
- Electromagnetic Compatibility Directive 2014/30/EU
- RoHS Directive 2011/65/EU
- ErP Directive 2009/125/EC and Regulation 2012/206/EC
- WEEE Directive 2012/19/EU
- F-Gas Regulation 2014/517/EU



## RANGE

---

Model	Code
AARIA START 25 N	20206326
AARIA START 35 N	20206327
AARIA START 50 N	20206328
AARIA START 70 N	20206330

## ACCESSORIES

For the complete list of accessories and the information relating to their usage combinations, please refer to [www.riello.it](http://www.riello.it).

## TABLE OF CONTENTS

---

<b>1</b>	<b>GENERAL INFORMATION</b> . . . . .	<i>p. 4</i>
1.1	General Notices . . . . .	<i>p. 4</i>
1.2	Safety precautions . . . . .	<i>p. 4</i>
1.3	Unit description . . . . .	<i>p. 5</i>
1.4	Safety and adjustment devices. . . . .	<i>p. 5</i>
1.5	Identification . . . . .	<i>p. 5</i>
1.6	Layout . . . . .	<i>p. 6</i>
1.7	Technical specifications . . . . .	<i>p. 8</i>
1.8	Operating limits . . . . .	<i>p. 9</i>
1.9	Cooling circuit . . . . .	<i>p. 10</i>
<b>2</b>	<b>INSTALLATION</b> . . . . .	<i>p. 11</i>
2.1	Receiving the product . . . . .	<i>p. 11</i>
2.2	Labels positioning . . . . .	<i>p. 11</i>
2.3	Dimensions and weight . . . . .	<i>p. 11</i>
2.4	Storage . . . . .	<i>p. 11</i>
2.5	Handling and removal of the packing . . . . .	<i>p. 12</i>
2.6	Place of installation . . . . .	<i>p. 12</i>
2.7	Recommended distances. . . . .	<i>p. 12</i>
2.8	Positioning. . . . .	<i>p. 12</i>
2.9	Installation on old systems or systems in need of upgrading . . . . .	<i>p. 14</i>
2.10	Refrigerating connection . . . . .	<i>p. 14</i>
2.11	Wiring diagram . . . . .	<i>p. 19</i>
2.12	Electrical connection . . . . .	<i>p. 19</i>
<b>3</b>	<b>COMMISSIONING AND MAINTENANCE</b> . . . . .	<i>p. 22</i>
3.1	Preparation for first commissioning . . . . .	<i>p. 22</i>
3.2	Putting into service . . . . .	<i>p. 22</i>
3.3	Ordinary maintenance . . . . .	<i>p. 23</i>
3.4	Operation signal and alarms . . . . .	<i>p. 24</i>
<b>4</b>	<b>DISPOSAL</b> . . . . .	<i>p. 26</i>

The following symbols are used on the product:



Avoid proximity to sources of ignition in continuous operation (open flames, gas household appliances, electric stoves, lit cigarettes, etc).



For more information, see the installation and technical service instructions.



Before performing maintenance and service tasks, read the installation and technical service instructions.



Before the installation, read the installation and technical service instructions.

The following symbols are used in this publication:















**WARNING** = actions requiring special care and appropriate training.





**DO NOT** = actions that **MUST ON NO ACCOUNT** be carried out.

## 1 GENERAL INFORMATION

### 1.1 General Notices









-  When you get the product, check immediately that the contents are all present and undamaged. Contact the dealer **RIELLO** if you notice any problems.
-  The product's installation must be carried out by an authorised company that will issue a declaration of the installation's conformity to the product's owner once the work has been completed, indicating that the work has been carried out in accordance with the standards of good practice, current National and Local regulations, and the indications provided by **RIELLO** in the instruction booklet accompanying the device.
-  The product must be used for its intended purpose, as stated by **RIELLO** for which it has been expressly manufactured. **RIELLO** shall bear no responsibility, whether of a contractual or non-contractual nature, for any damage caused to people, animals, or property due to incorrect installation, adjustments, or maintenance, or improper use.
-  Suitable clothing, instrumentation, and accident-prevention devices must be utilized during the installation and/or maintenance operations. **RIELLO** shall bear no responsibility for any failure to comply with current safety and accident-prevention regulations.
-  During installation and/or service operations, keep the area around the unit tidy and clean.
-  Comply with the legislation in force on the country of deployment with regard to the use and disposal of packaging, of cleaning and maintenance products and for the management of the unit's decommissioning.
-  Any repair and maintenance interventions must be carried out by **RIELLO** Technical Support Service, in accordance with the provisions contained in this publication. Do not modify or tamper with the unit as dangerous situations may arise and the unit manufacturer will not be liable for any damage caused.
-  In the event of any functional anomalies or fluid leaks, set the system's main switch to its "off" position. Promptly contact your local **RIELLO** Technical Support Service, and do not perform any interventions upon the device on your own.
-  The units contain refrigerant gas: operate carefully so as to avoid damaging the gas circuit and the fin bank.
-  Do not place any inflammable object (spray cans) within a 1 metre radius from the air expulsion.
-  According to EU Regulation no. 517/2014 regarding certain fluorinated greenhouse gases, the total amount of refrigerant contained within the installed system must be indicated. This information can be found on the unit technical data plate.
-  This unit contains fluorinated greenhouse gases covered by the Kyoto protocol. Maintenance and disposal activities must be carried out exclusively by skilled personnel.

 The R32 refrigerant gas is slightly inflammable and odourless. Carefully read the safety data sheet available from the dealer.

 This booklet is an integral part of the device, and must therefore be carefully preserved, and must ALWAYS accompany it, even in the event that it is sold to another Owner or User, or is transferred to another system. If it is damaged or lost, another copy can be requested to **RIELLO** Technical Support Service in your Area.

### 1.2 Safety precautions

It should be noted that the use of products that utilize electric energy requires certain essential safety regulations to be respected, including the following:

-  Do not allow children or unassisted disabled people to use the unit.
-  Do not touch the unit while barefoot and/or partially wet.
-  Do not spray or throw water directly on the unit.
-  It is forbidden to place weights on the device.
-  It is strictly forbidden to touch the coil fins, the moving parts, to place any body parts between them, or to insert pointy objects into the grilles.
-  It is forbidden to perform any technical interventions or cleaning operations before having disconnected the device from its electrical power supply, by setting the system's main switch to its "OFF" position.
-  It is forbidden to modify the safety or regulation devices without the authorisation of the manufacturer.
-  Do not pull, detach or twist the electrical wires coming out of the unit, even when the unit is disconnected from the power grid.
-  The packing material must not be disposed of in the surrounding environment and must be kept out of children reach, as it can be dangerous. It must be disposed of according to the regulations in force.

### 1.3 Unit description

**RIELLO AARIA STARTN** is a heat pump outdoor unit that can be coupled to indoor units of the same series for the air-conditioning of small/middle-sized rooms. Designed for outdoor installation, it is suitable for use in residential and small business premises. The rotary compressor is regulated by the DC-Inverter control with continuous modulation, ensuring high energy standards. The DC motor of the fan improves performance and sound comfort. The expansion valve electronically optimises the refrigerant flow in the circuit (model 70 N only).

### 1.4 Safety and adjustment devices

The device safety and setting are achieved thanks to

- compressor motor thermal protection, which is triggered in case the current consumed by the compressor is excessive
- gas delivery temperature sensor, which transmits the detected value to the electronic board that is triggered in case of overtemperature (110°C)
- anti-freeze sensor, which transmits the temperature value as detected by the heat exchanger to the electronic board that is triggered when the heat exchanger is clogged by frost formations
- outdoor air temperature sensor, which transmits the detected value to the electronic board that is triggered in order to adjust the operation of the unit indoor components to the variation of weather conditions
- Internal coil temperature sensor, transmits the temperature value detected on the internal heat exchanger to the electronic board, which intervenes in the event of over-temperature (63°C)

**⚠** Safety device replacement must be carried out by **RIELLO** Technical Support Service, using only original components. Please refer to the spare parts catalogue.

**⊘** IT IS FORBIDDEN to operate the device with faulty safety systems.

### 1.5 Identification

The unit can be identified through the technical data plate:

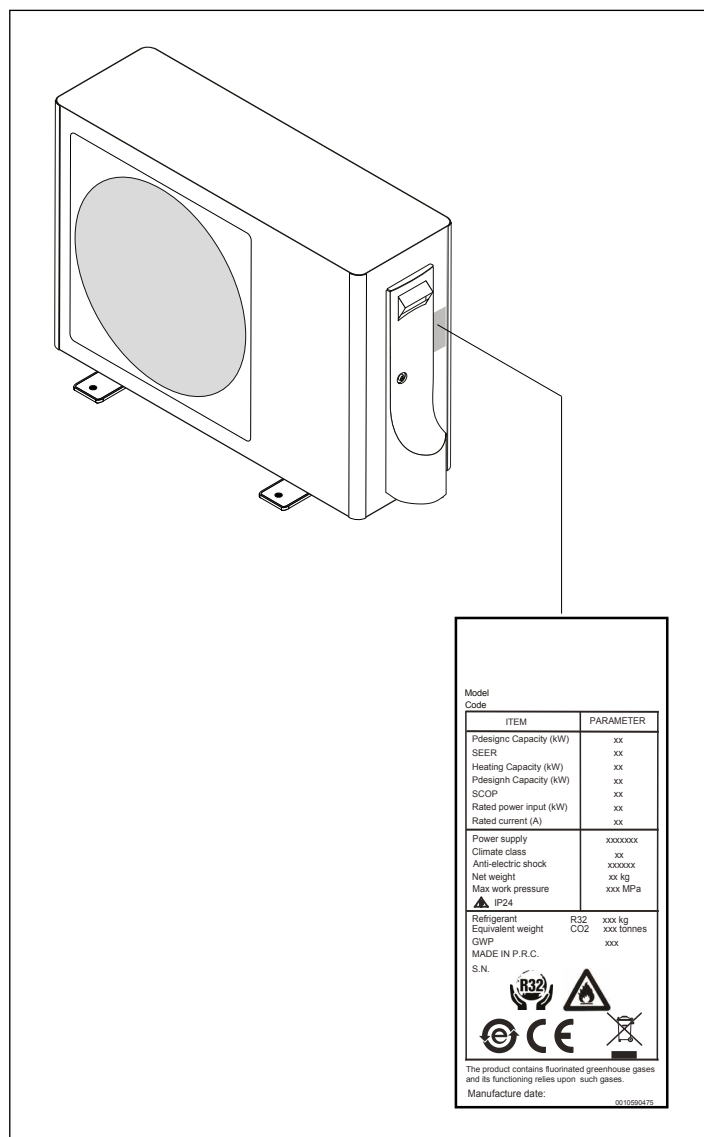

#### Technical data plate

Contains the device's technical and performance data.

**⚠** The tampering, removal, or absence of the identification plates will not allow the product to be properly identified by its serial number.

1.6 Layout

MODEL 25 N - 35 N

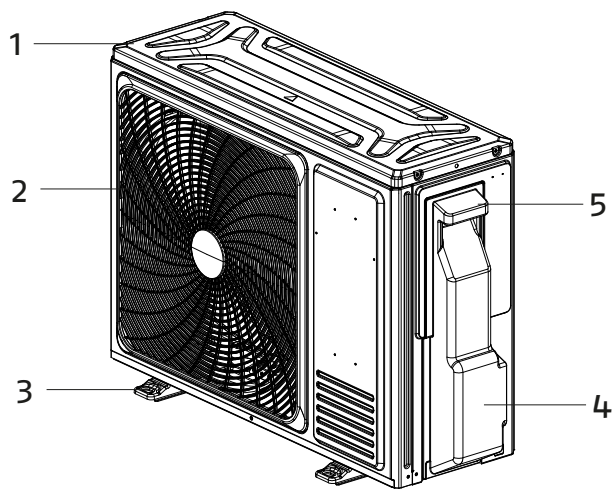

- 1 Upper panel
- 2 Fan protection grille
- 3 Support bracket
- 4 Connections cover
- 5 Handle for handling
- 6 Heat exchanger

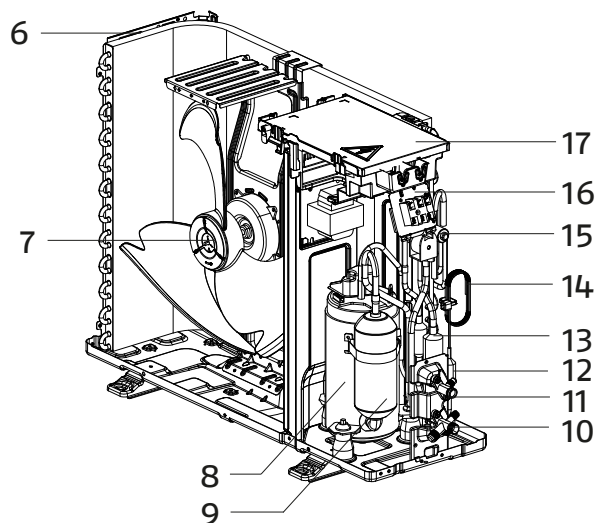

- 7 Electric fan
- 8 Rotary compressor
- 9 Intake separator
- 10 Gas line connection
- 11 Liquid line connection
- 12 Filter

- 13 Muffler
- 14 Capillary tube
- 15 Cycle reversal valve
- 16 Terminal board for electric connections
- 17 Electric panel cover

MODEL 50 N

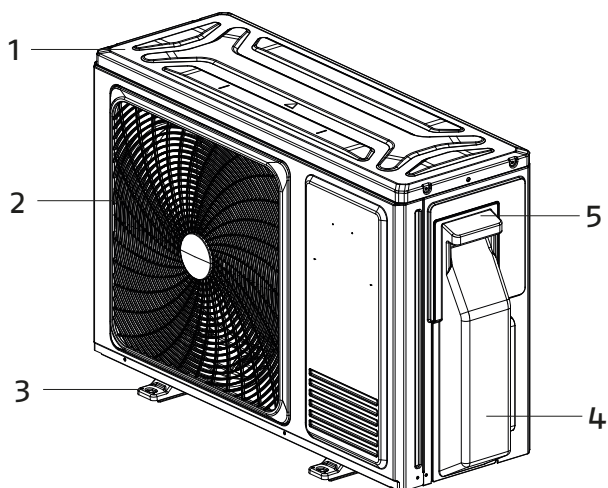

- 1 Upper panel
- 2 Fan protection grille
- 3 Support bracket
- 4 Connections cover
- 5 Handle for handling
- 6 Heat exchanger

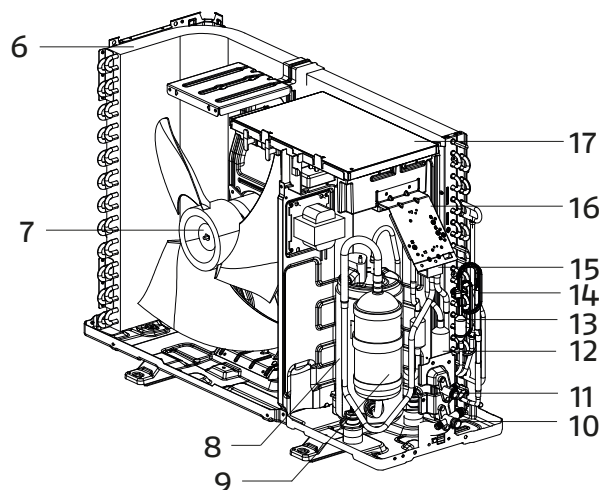

- 7 Electric fan
- 8 Rotary compressor
- 9 Intake separator
- 10 Gas line connection
- 11 Liquid line connection
- 12 Muffler

- 13 Filter
- 14 Capillary tube
- 15 Cycle reversal valve
- 16 Terminal board for electric connections
- 17 Electric panel cover

MODEL 70 N

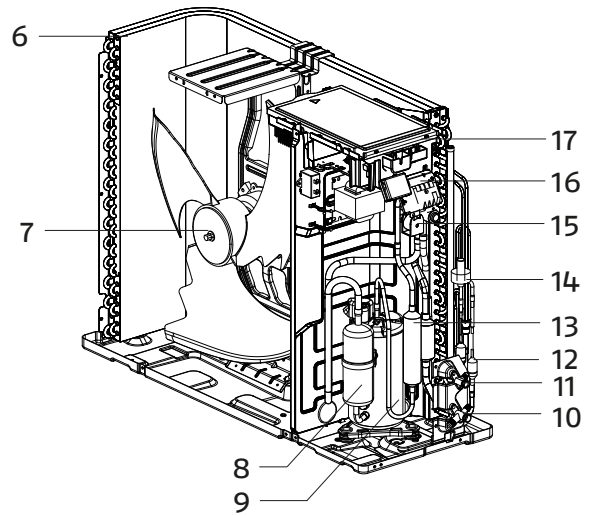

- 1 Upper panel
- 2 Fan protection grille
- 3 Support bracket
- 4 Connections cover
- 5 Handle for handling
- 6 Heat exchanger

- 7 Electric fan
- 8 Rotary compressor
- 9 Intake separator
- 10 Gas line connection
- 11 Liquid line connection
- 12 Filter

- 13 Muffler
- 14 Electronic expansion valve
- 15 Cycle reversal valve
- 16 Terminal board for electric connections
- 17 Electric panel cover

**1.7 Technical specifications**
**Performance combined with AMW ST N**

Riello model		25 N	35 N	50 N	70 N
<b>Cooling performance [A35 / A27] <sup>(1)</sup></b>					
Capacity at rated air flow	kW	2,60	3,20	5,00	6,80
Absorbed power at rated air flow	kW	0,80	0,99	1,55	2,11
EER	kW/kW	3,23		3,41	3,23
Capacity at maximum air flow	kW	3,00	3,60	5,80	8,50
Absorbed power at maximum air flow	kW	1,20	1,60	2,00	2,90
Capacity at minimum air flow	kW	0,80		1,30	2,20
Absorbed power at minimum air flow	kW	0,30		0,40	0,70
<b>Cooling energy data <sup>(2)</sup></b>					
SEER	kW/kW	6,10			6,80
Energy class		A++			
Annual energy cons.	kWh/annum	149	184	287	350
<b>Heating performance [A7 / A20] <sup>(3)</sup></b>					
Capacity at rated air flow	kW	2,80	3,40	5,20	6,80
Absorbed power at rated air flow	kW	0,75	0,92	1,40	1,83
COP	kW/kW	3,71			
Capacity at maximum air flow	kW	3,20	4,20	6,00	9,50
Absorbed power at maximum air flow	kW	1,40	1,60	2,50	2,90
Capacity at minimum air flow	kW	0,80		1,40	2,40
Absorbed power at minimum air flow	kW	0,30		0,52	0,60
<b>Energy data for Average climatic profile <sup>(4)</sup></b>					
Pdesign at -10 °C	kW	2,40	2,80	4,60	5,60
SCOP	kW/kW	4,00			
Energy class		A+			
Annual energy cons.	kWh/annum	840	980	1610	1960
<b>Energy data for Warm climatic profile <sup>(4)</sup></b>					
Pdesign at +2 °C	kW	2,00	2,70	4,10	5,60
SCOP	kW/kW	5,10			
Energy class		A+++			
Annual energy cons.	kWh/annum	549	741	1125	1538

(1) Outdoor air: 35 °C D.B., Indoor air: 27 °C D.B. / 19 ° W.B.

(2) In compliance with 626/2011 regulation

(3) Outdoor air: 7 °C D.B. / 6 °C W.B., Indoor air: 20 °C D.B.

(4) In compliance with EU 206/2012 regulation

## Outdoor unit data

Riello model		25 N	35 N	50 N	70 N
<b>Cooling performance [A35 / A27] <sup>(1)</sup></b>					
Nominal capacity	kW	2,60	3,20	5,00	6,80
Nominal power input	kW	0,80	0,99	1,55	2,11
Rated frequency	Rps	54	61	70	74
Maximum frequency	Rps	75		85	
Minimum frequency	Rps	31		20	22
Nominal current consumption	A	3,60	4,50	7,00	9,17
Max. current input	A	6,20	7,10	8,90	13,00
Minimum current consumption	A	1,40		2,30	2,60
<b>Heating performance [A7 / A20] <sup>(2)</sup></b>					
Nominal capacity	kW	2,80	3,40	5,20	6,80
Nominal power input	kW	0,75	0,92	1,40	1,83
Rated frequency	Rps	58	57	73	68
Maximum frequency	Rps	99		112	109
Minimum frequency	Rps	31		20	22
Nominal current consumption	A	3,50	4,20	6,30	7,00
Max. current input	A	6,20	7,10	11,30	13,00
Minimum current consumption	A	1,40		2,30	2,60
<b>Electrical characteristics</b>					
Power supply	V/Ph/Hz	230/1/50			
<b>Compressor</b>					
Compressor	Type	Rotary			
Oil	Type	ACS-68R			FW68S
Oil charge	l	0,32		0,44	0,35
Refrigerant	Type	R32			
Refrigerant charge	kg	0,52	0,53	0,90	1,10
<b>Fan</b>					
Fan	Type	Axial - DC			
Quantity	no.	1			
Nominal air flow	m <sup>3</sup> /h	2100		2500	2600
Minimum speed	rpm	300			
Maximum speed	rpm	900	850	950	
Maximum power input	kW	0,04			
<b>Cooling sound levels</b>					
Sound power level	dB(A)	60	61	63	65
Sound pressure level	dB(A)	47	48	52	53
<b>Heating sound levels</b>					
Sound pressure level	dB(A)	47	48	52	53
Sound power level	dB(A)	60	61	63	65

(1) Outdoor air: 35 °C D.B., Indoor air: 27 °C D.B. / 19 °C W.B.

(2) Outdoor air: 7 °C D.B. / 6 °C W.B., Indoor air: 20 °C D.B.

## 1.8 Operating limits

Operating mode	Temperature		Min	Max
	Indoor air (D.B.)	Outdoor air (D.B.)		
Cooling	Indoor air (D.B.)	°C	21	35
	Outdoor air (D.B.)	°C	-10	43
Heating	Indoor air (D.B.)	°C	10	27
	Outdoor air (D.B.)	°C	-15	24

The values are based on the following condition:

- pipe length: 5 m
- difference in height: 0 m
- air flow: maximum

### 1.9 Cooling circuit

The cooling circuit is of the heat pump type with a refrigerant gas reversal cycle. The source fluid utilised is the outdoor air, while the utility-side fluid is the air inside the rooms. During the wintertime, the heat pump extracts the thermal en-

ergy from the outdoor air and delivers it to the room air, thereby heating it. During the summertime the cycle is reversed, and the thermal energy is extracted from the room air, which is cooled, and is delivered to the outdoor air.

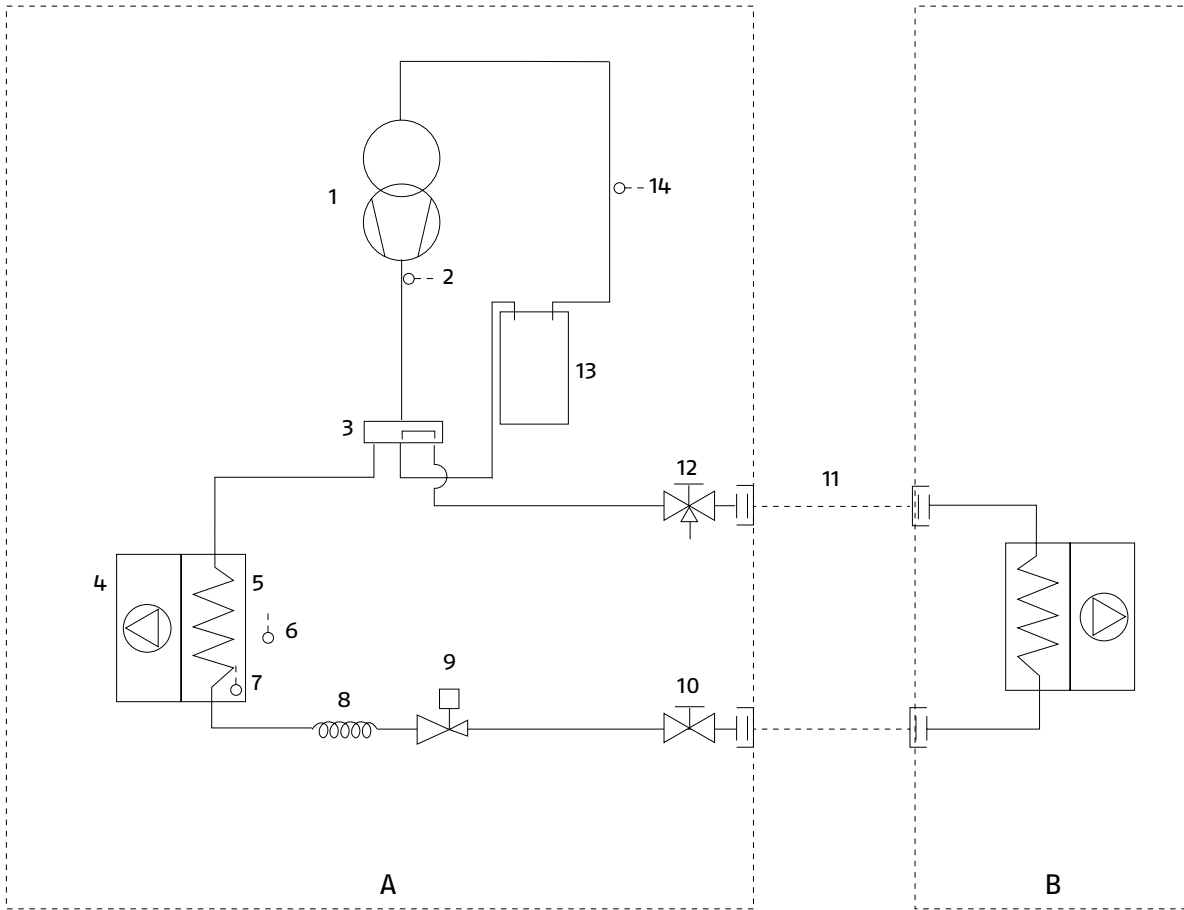

- |                                       |  |                                    |
|---------------------------------------|--|------------------------------------|
| <b>A</b> Outdoor unit                 | <b>5</b> Heat exchanger                                  | <b>10</b> Two-way shut-off valve   |
| <b>B</b> Indoor unit                  | <b>6</b> External air probe                              | <b>11</b> Connection pipes         |
| <b>1</b> Compressor                   | <b>7</b> Defrost temperature sensor                      | <b>12</b> Three-way shut-off valve |
| <b>2</b> Discharge temperature sensor | <b>8</b> Capillary tube                                  | <b>13</b> Intake separator         |
| <b>3</b> Cycle reversal valve         | <b>9</b> Electronic expansion valve (model 24000-1 only) | <b>14</b> Intake sensor            |
| <b>4</b> Electric fan                 |  |                                    |

## 2 INSTALLATION

**⚠** Ensure that the installation and operation sites are properly ventilated in order to disperse any gas leaks that could cause flames during activities with intense heat generation and high temperature.

**⚠** Avoid proximity to sources of ignition in continuous operation (open flames, gas household appliances, electric stoves, lit cigarettes, etc).

**⚠** Use equipment suitable for the system refrigerant.

**⚠** Use an electronic leak finder properly calibrated for the system refrigerant.

**⊖** It is forbidden to use leak finders with halogen lamps.

### 2.1 Receiving the product

**RIELLO AARIA START N** is supplied in a single pack, protected by a cardboard box and by polystyrene elements. The following material is placed inside the packaging, below the unit

Document envelope:

- Instruction's book for the installer and for the Technical Service in Italian
- Instruction's book for the installer and for the Technical Service in English
- Warranty/Spare parts labels.
- energy label
- etichetta gas refrigerante
- contact sheet

It is also supplied as kit:

- Condensate outlet hose.
- 4 x vibration dampers
- screws to connect refrigerant connections cover

**⚠** When you get the product, check immediately that the contents are all present and undamaged. Contact the dealer **RIELLO** if you notice any problems.

**⚠** The Instruction book comes with the equipment and it should be taken, read and kept carefully.

**⚠** The document envelope must be kept in a safe place. Any duplicate must be requested from RIELLO S.p.A. which reserves to charge the cost.

### 2.2 Labels positioning

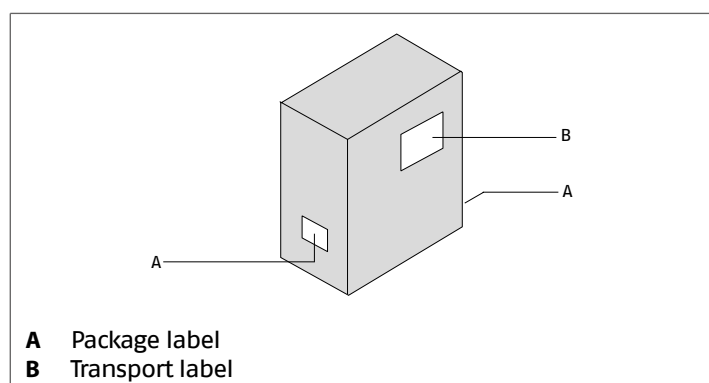

### 2.3 Dimensions and weight

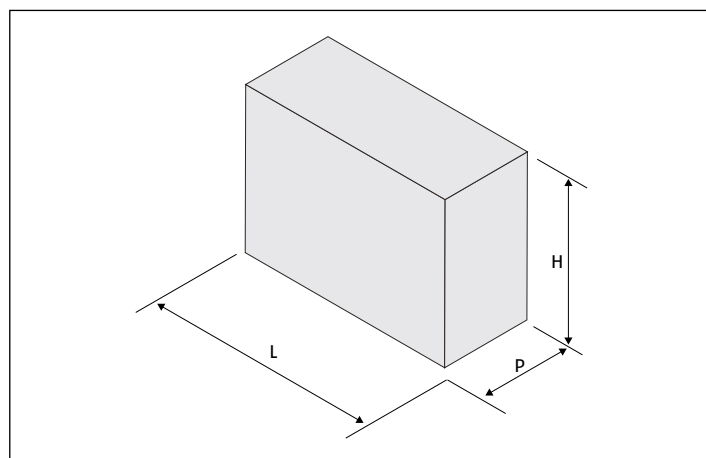

Riello model		25 N	35 N	50 N	70 N
<b>Packaging dimensions</b>					
H	mm	585	585	607	780
L	mm	819	819	902	1046
P	mm	320	320	375	460
Weight	kg	25,3	26,0	36,5	48,0

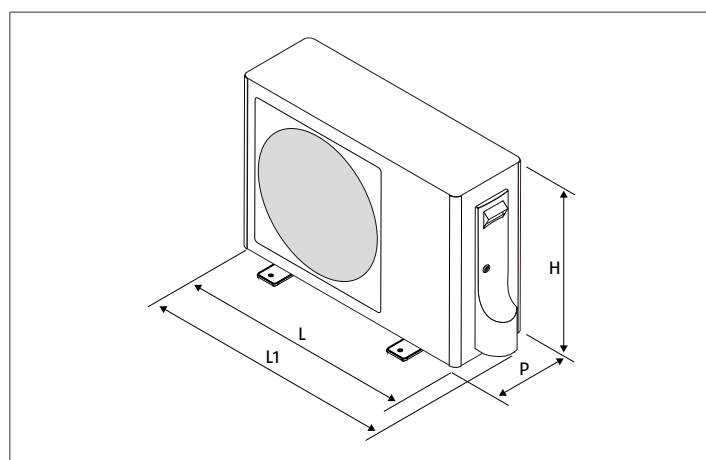

Riello model		25 N	35 N	50 N	70 N
<b>Product dimensions</b>					
H	mm	544	544	550	705
L	mm	700	700	800	890
L1	mm	777	777	868	969
P	mm	245	245	280	340
Weight	kg	22,8	23,5	32,7	44,0

### 2.4 Storage

If the product is stored in a room before installation check:

- there aren't continuously operating ignition sources (open flames, gas appliances, electric heaters,..) within a radius of 2.5 m.
- there is adequate ventilation

**⚠** The product must be stored according to the regulations in force.

## 2.5 Handling and removal of the packing

**⚠** Before unpacking, personal protective clothing should be worn and used transport means and tools suitable for the size and weight of the unit.

**⚠** Check refrigerant leak inside the packaging with a leak detector suitable for the refrigerant used in the system. If a gas leak is detected, probably the refrigerant circuit is damaged and the product can't be installed; finally call Technical Service **RIELLO**.

Product handling can also be done manually by grasping the handles provided on the packaging.

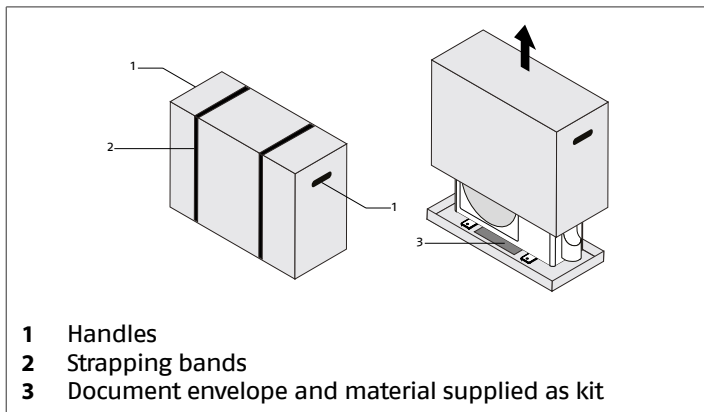

Follow the below instructions for packing removal and product handling:

- transport the equipment in the installation place
- cut strapping bands
- lift and remove the cardboard pack
- handle the unit by grasping the handles provided.
- remove the document envelope

**⚠** In manual operation it is compulsory to respect always the maximum weight per person provided for by the national laws and standards.

**⚠** Handle with care

**⚠** The equipment must always be handled vertically

**⚠** Do not tilt the equipment over 15°

**⚠** The unit's weight is concentrated on the compressors side (connection covering side).

**⊖** The packing material must not be disposed of in the surrounding environment and must be kept out of children reach, as it can be dangerous. It must be disposed of according to the regulations in force.

## 2.6 Place of installation

The location of **RIELLO AARIA START N** devices must be determined by the system's designer or by another competent person, and must take into account the technical requirements, as well as any current local regulations that require specific permits to be obtained. (e.g.: zoning, architectural, environmental protection, etc.).

It is therefore recommended to obtain all the necessary permits before installing the device.

**RIELLO AARIA START N** is designed for outdoor installation.

**Avoid:**

- positioning the unit in air shafts and/or basement window wells
- any obstacles or barriers that will cause the expelled air to recirculate
- locations with aggressive or explosive atmospheres or with inflammable fluids
- confined locations in which the device's sound levels might be compounded by reverberations or resonances
- proximity to bedrooms and rooms for resting
- positioning in corners where dust, leaves, or any other materials typically accumulate, which could compromise the device efficiency by obstructing the airflow
- situations in which the air expelled from the device might enter the habitation through doors or windows, thus creating an inconvenience for the people inside
- situations in which the air expelled from the device will encounter resistance from opposing winds
- direct exposure to sunlight and proximity to heat sources

**⚠** Avoid placing the unit less than 1 metre away from radio and video systems.

**⚠** If the unit is installed in a windy location, fit an anti-wind grille to protect the fan and check the correct functioning of the unit.

**⚠** Decide where to place the unit considering the length of cooling lines and the maximum difference of height allowed between the devices.

## 2.7 Recommended distances

The distances for the device installation and maintenance are shown in the figure. The indicated spaces are necessary in order to prevent the airflow from being blocked, as well as to allow normal cleaning and maintenance operations to be carried out.

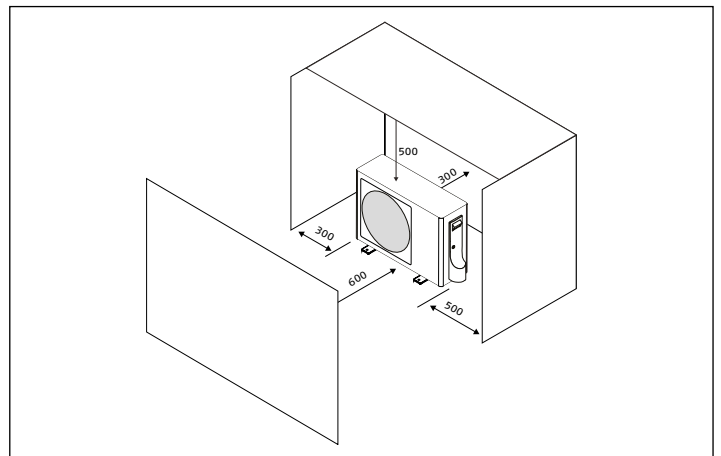

## 2.8 Positioning

**RIELLO AARIA START N** devices must:

- be positioned on a level surface that is capable of supporting their weight
- be positioned on a sufficiently rigid surface that will not transmit any vibrations to the underlying or adjacent rooms

**⚠** Use the anti-vibration supports supplied with the device.

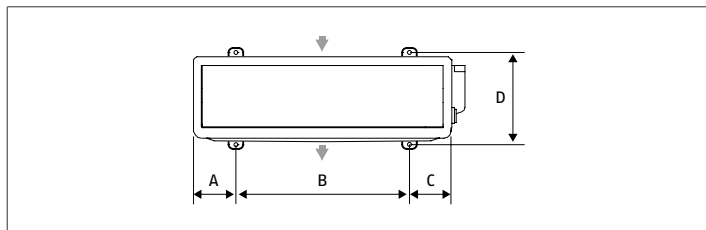

Riello model		25 N	35 N	50 N	70 N
A	mm	139	139	180	130
B	mm	500	500	440	630
C	mm	61	61	180	130
D	mm	256	256	313	374

They can be placed on the floor or suspended on supporting brackets.

### Positioning on floor

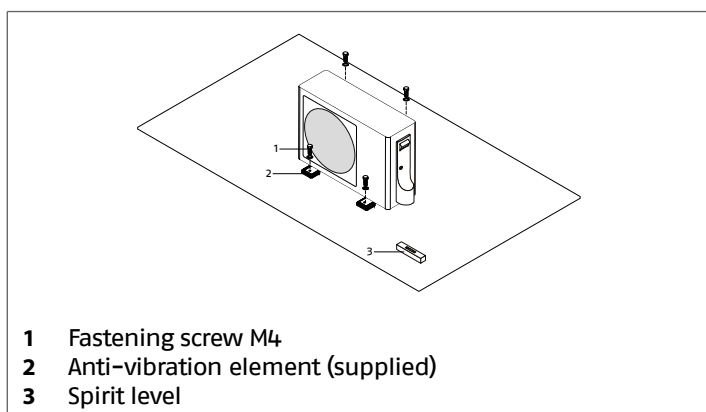

- 1 Fastening screw M4
- 2 Anti-vibration element (supplied)
- 3 Spirit level

- screw the unit to the ground
- tighten using a torque wrench
- apply a tightening torque of 3.5 Nm

Provide for lifting of the unit from the floor:

- 20 mm without conveying of the condensate outlet
- 90 - 100 mm to allow for the condensate discharge

**⚠** If the device is installed in an area that is subject to heavy snowfalls, place the unit in a raised position so as to prevent the air flow from being blocked or install a roofing to protect it.

**⚠** Adequate anti-freeze systems should be used for installations in extremely cold areas, where there is a possibility of freezing.

**⚠** While operating in heating mode, the unit generates condensate, which will deposit on the support surface if there is not discharge. This could freeze if the outdoor temperatures are below zero, thus creating a hazard. In this case, appropriate barriers should be installed in order to prevent people from approaching the unit.

**⚠** Test

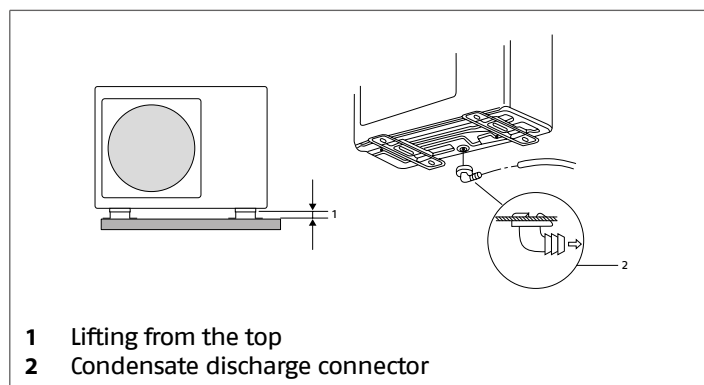

- 1 Lifting from the top
- 2 Condensate discharge connector

Riello model		25 N	35 N	50 N	70 N
Condensate discharge attachment $\varnothing$	mm	16			

### Hanging position

**⚠** Properly sized supporting brackets must be used if the device is installed in suspension.

**⚠** Ensure that the wall section does not include bearing elements, pipes or electric lines.

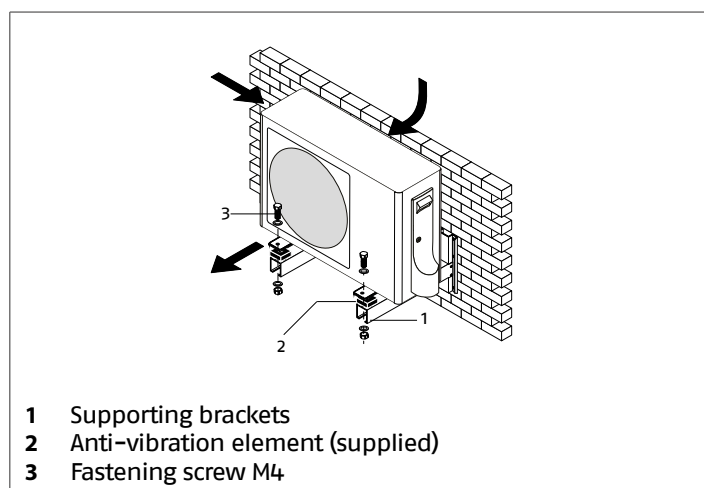

- 1 Supporting brackets
- 2 Anti-vibration element (supplied)
- 3 Fastening screw M4

## 2.9 Installation on old systems or systems in need of upgrading

When **RIELLO AARIA START N** is installed on old systems or systems in need of upgrading, it is recommended to ensure that:

- the electrical system is compliant with the applicable regulations and has been installed by qualified professionals

**⚠** In the event of a replacement, the system must be inspected by the designer or by another competent person, and must be compliant with the technical requirements, as well as the current legislations and regulations.

**⚠** The manufacturer shall bear no responsibility for any damages caused by incorrect system installation.

## 2.10 Refrigerating connection

The dimensions and positions of **RIELLO AARIA START N** cooling connections are shown hereunder.

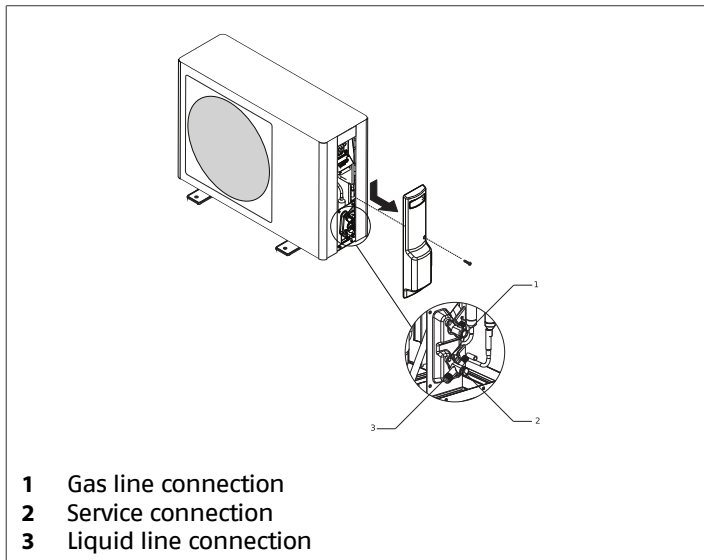

Riello model		25 N	35 N	50 N	70 N
Liquid line connection	Inches		1/4		
Gas line connection	Inches	3/8		1/2	
Charge connection	Inches		1/2		
Liquid line connection	mm		6,35		
Gas line connection	mm	9,52		12,7	
Charge connection	mm		12,7		

To access the cooling connections:

- unscrew the fastening screw
- push down the connection covering panel
- remove the connection covering panel

The cooling pipes must respect the lengths and differences in height as indicated in the following table.

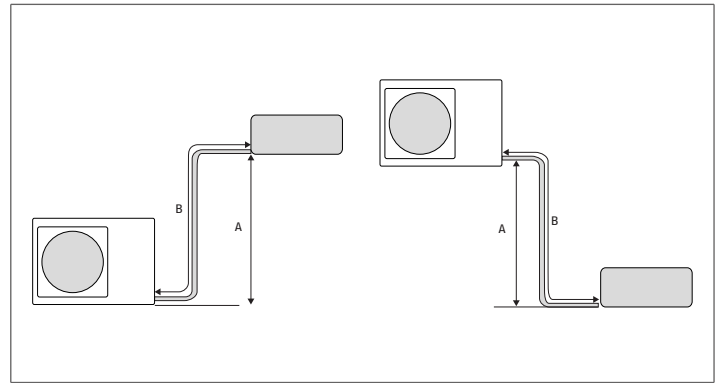

Riello model		25 N	35 N	50 N	70 N
A	m	10		15	
B	m	15	20	25	
Maximum length with standard charge	m	5		7	
Minimum length of the single refrigeration line	m	3			
Additional charge	g/m	20			

Use pipes with the thickness indicated in the following table:

Pipe Ø		Thickness
mm	inches	mm
6,35	1/4	0,8
9,52	3/8	0,8
12,70	1/2	0,8
15,88	5/8	1,0

**Maximum operating pressure 4.3 Mpa.**

- ⚠** In case of a drop in excess of 5 m, a siphon must be installed every 5-7 metres.
- ⚠** The given measures are the maximum permitted values.
- ⚠** Cooling connections featuring shut-off valves are preconfigured for flare connections.
- ⚠** Cooling lines must be as straight as possible and any necessary bends must have a radius greater than 40 mm.
- ⚠** Use clean hoses. Make sure the inside is free of dust, residues, water.
- ⚠** Avoid the entry of uncondensable gases (air) in the circuit, otherwise, with the unit in operation, high pressures with the risk of damages might ensue.
- ⚠** Use copper pipes for cooling systems.
- ⚠** Use connecting pipes and tools appropriate for the system's refrigerant.
- ⊖** It is forbidden to use second-hand cooling lines since their flare connection seal is not guaranteed.
- ⊖** It is forbidden to use pre-charged cooling lines.
- ⊖** It is forbidden to carry out welding operations with refrigerant inside the cooling circuit. If necessary, the refrigerant must be recovered and the circuit must be cleaned with nitrogen without oxygen.

**Connections**

- position the connecting pipes

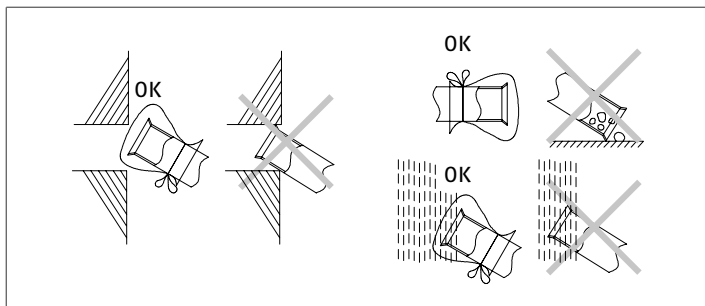

**⚠** Before threading the lines through the hole in the wall, close the lines ends.

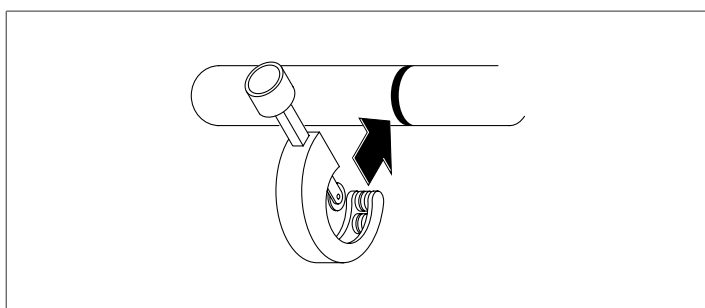

- cut the pipe end square using a pipe cutter
- remove burrs keeping the cut edge facing down
- remove the flare nut on the unit connection
- insert it into the connection pipe
- flare the tube

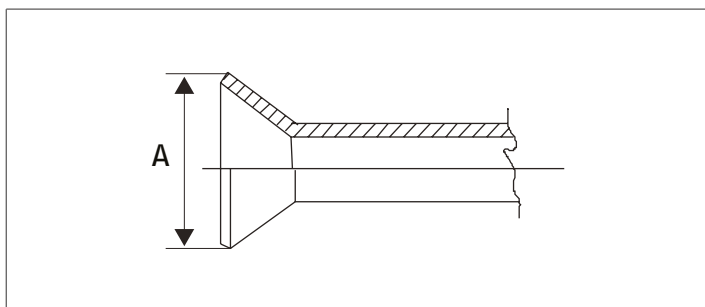

Pipe Ø		A
mm	inches	mm
6,35	1/4	9,1
9,52	3/8	13,2
12,70	1/2	16,6
15,88	5/8	19,7

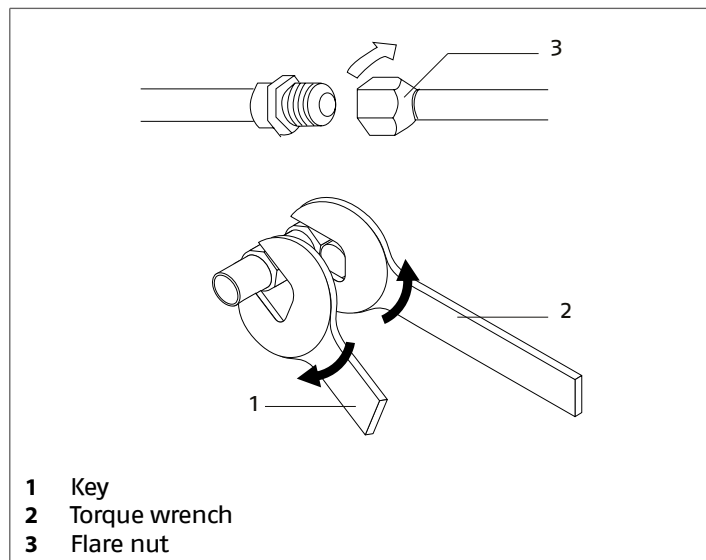

- 1 Key
- 2 Torque wrench
- 3 Flare nut

Pipe Ø		Tightening torque
mm	inches	Nm
6,35	1/4	18-20
9,52	3/8	30-35
12,70	1/2	35-45
15,88	5/8	45-55

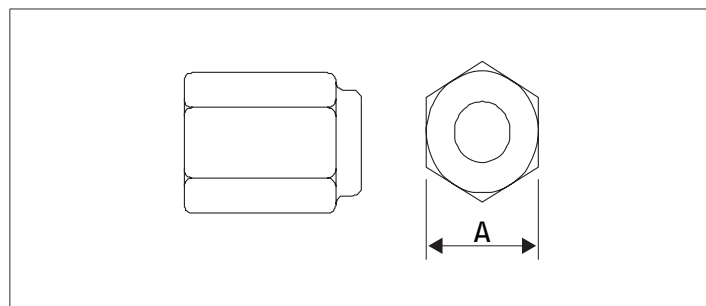

Pipe Ø		A
mm	inches	mm
6,35	1/4	17
9,52	3/8	22
12,70	1/2	26
15,88	5/8	29

- bring line ends with flare connection close to their coupling on the unit
- manually rotate the flare nuts by 3 - 4 turns
- tighten the connections using a spanner and a counter spanner

**⚠** Use a torque wrench to tighten so as to prevent damage to flare nuts and gas leaks.

**⚠** Use equipment suitable for the system refrigerant.

**⚠** During the connection, keep the leak finder on and close to the unit so that it signals any refrigerant leak.

**⚠** Avoid using the refrigerant oil on the external part of the flaring.

## INSTALLATION

- ⚠** Avoid proximity to sources of ignition in continuous operation (open flames, gas household appliances, electric stoves, lit cigarettes, etc).

After connecting the cooling pipes:

- create a vacuum inside the pipes
- check for refrigerant leaks
- apply thermal insulating material on the joints

### Pipe insulation

Connection pipes must be thermally insulated to prevent dispersions of heat or formation of condensate.

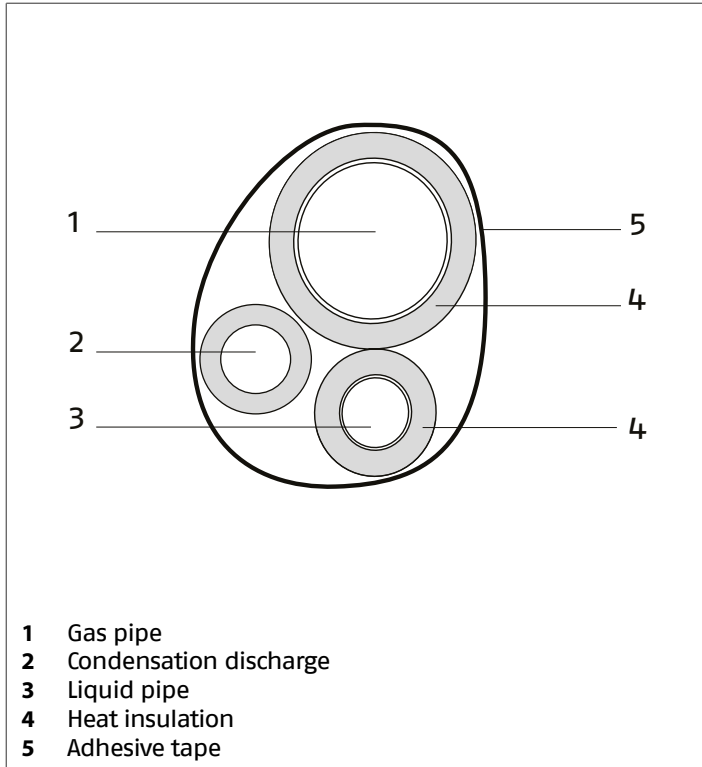

- insulate the liquid and gas pipes separately
- use insulating material that is thicker than 15 mm
- ensure that the insulating material adheres to the pipe without gaps
- fix using adhesive tape

- ⚠** Do not tighten the adhesive tape too much, so as to avoid damaging the insulation.

- ⚠** Avoid partial insulation of the pipes.

- ⚠** In case of use with outdoor temperature above 30 °C and relative humidity above 80%, increase wall thickness up to 20 mm.

For gas pipes:

- ensure that the material used resists to temperatures up to 120°C

For liquid pipes:

- ensure that the material used resists to temperatures up to 70°C

### Stop valves

Cooling connections feature shut-off valves. During operations on the cooling circuit, start-up and service, it may be required to open and close the valves.

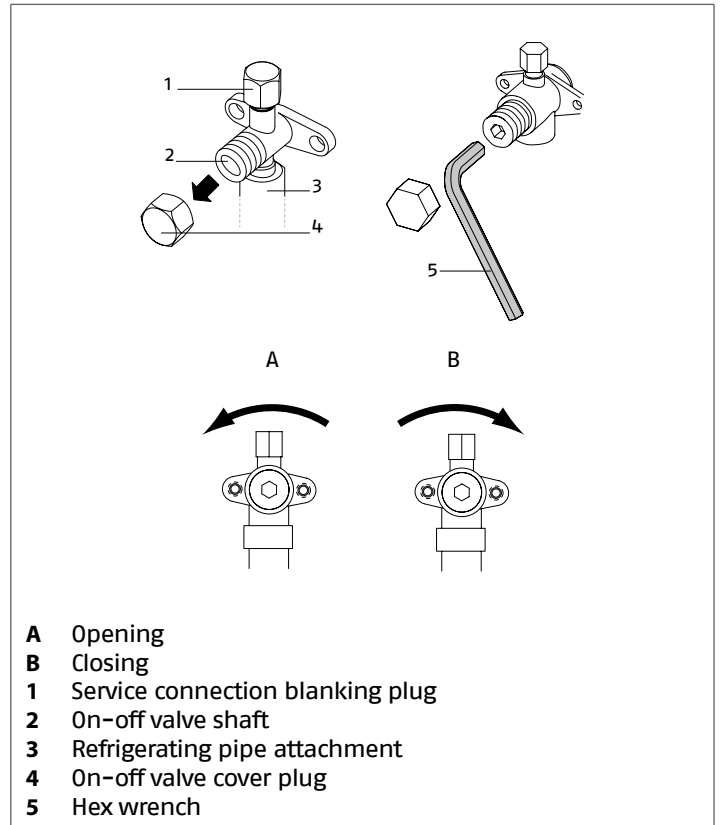

If required:

- remove the valve covering plug
- operate on the valve shaft with an hex wrench
- open or close according to what is needed
- immediately stop as soon as the valve shaft has reached the stop point
- use a torque wrench calibrated on the valve diameter

Pipe Ø		Hex wrench	Valve tightening torque	Plug tightening torque
mm	inches	mm	Nm	Nm
6,35	1/4	5	6	25
9,52	3/8	5	6	25
12,70	1/2	5	8	30
15,88	5/8	5	10	35

- ⚠** Do not force beyond the stop point to prevent damaging the shaft and causing leakage as a consequence.

At the end of the operations:

- refit the valve covering plug

- ⚠** Carefully check for absence of leakages from the closing point of the plug.

### Circuit tightness check

The appliance is tested at the factory and the indoor refrigerating circuit tightness does not usually need to be checked. The refrigerating circuit built on site needs to be checked instead.

**To check tightness:**

- keep the outdoor unit shut-off valves closed

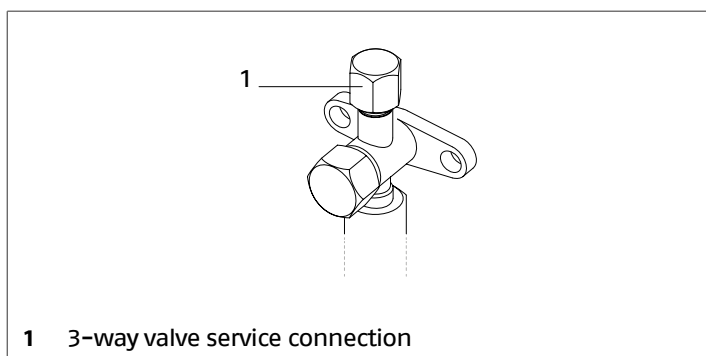
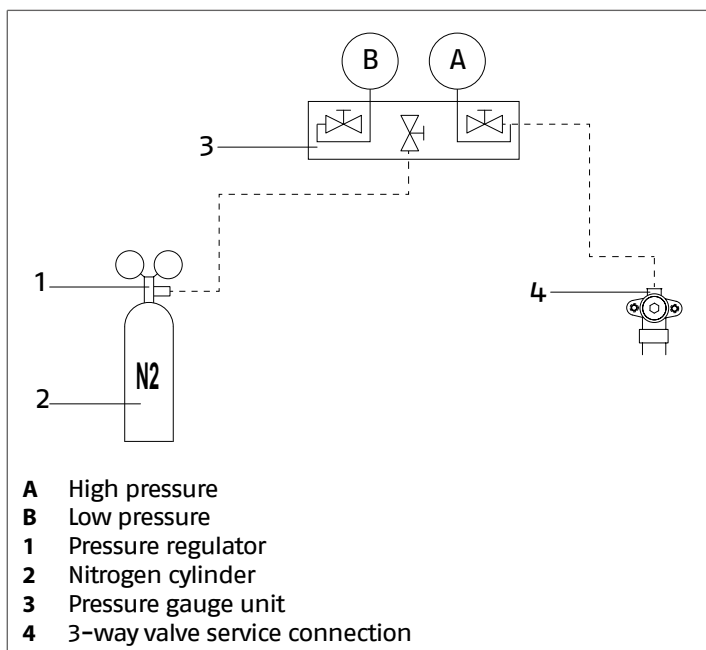

- charge the circuit with nitrogen through the service connection on the 3-way shut-off valve

**⚠** Do not use oxygen or acetylene or other flammable or poisonous gases in the refrigerating circuit, as they can cause explosions.

- reach a pressure equal to 0.3 Mpa
- wait 3 minutes.
- check that the pressure has not dropped
- reach a pressure equal to 1.5 Mpa
- wait 3 minutes.
- check that the pressure has not dropped
- reach a pressure equal to 3 Mpa
- adjust the reached pressure and room temperature
- leave the circuit pressurised for 1 day
- check that the pressure has not dropped

**⚠** If the temperature has changed with respect to the noted value consider that the pressure varied by 0.01 Mpa for 1 °C.

**⚠** If pressure has dropped, detect the leak, fix it and repeat the test.

**⚠** To detect the leak, use a solution of water and soap and check all the joints and welds, if any.

**Having verified the absence of leakages:**

- create a pneumatic vacuum inside the circuit

**Pneumatic vacuum**

**To create vacuum in the circuit:**

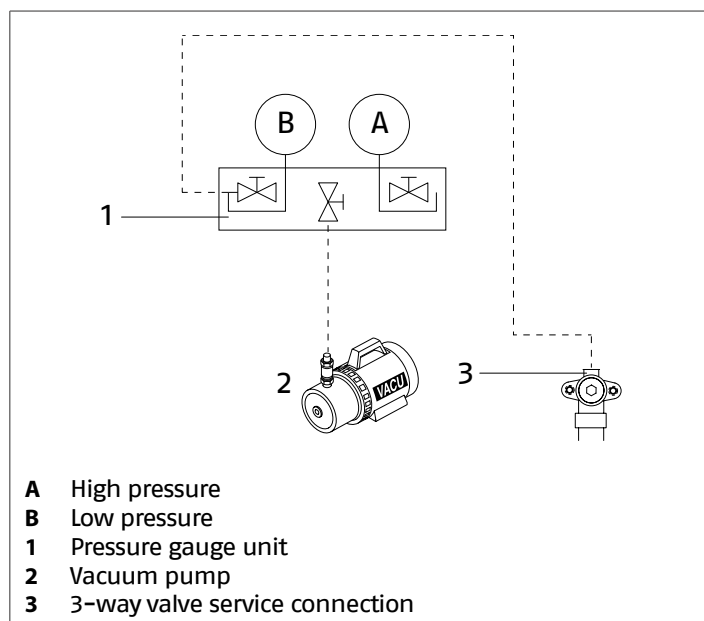

- keep the outdoor unit shut-off valves closed
- connect the vacuum pump to the pressure gauge unit
- connect the pressure gauge unit to the service connection on the 3-way shut-off valve
- completely close the pressure reducing valve of the pressure gauge
- fully open the low pressure valve of the pressure gauge unit
- let the vacuum pump work for at least 15 minutes
- reach a pressure that is close to -0.1 Mpa
- close the low pressure valve of the pressure gauge unit
- switch off the vacuum pump
- wait 5 minutes
- check that the pressure has not risen again

**If the pressure has risen again:**

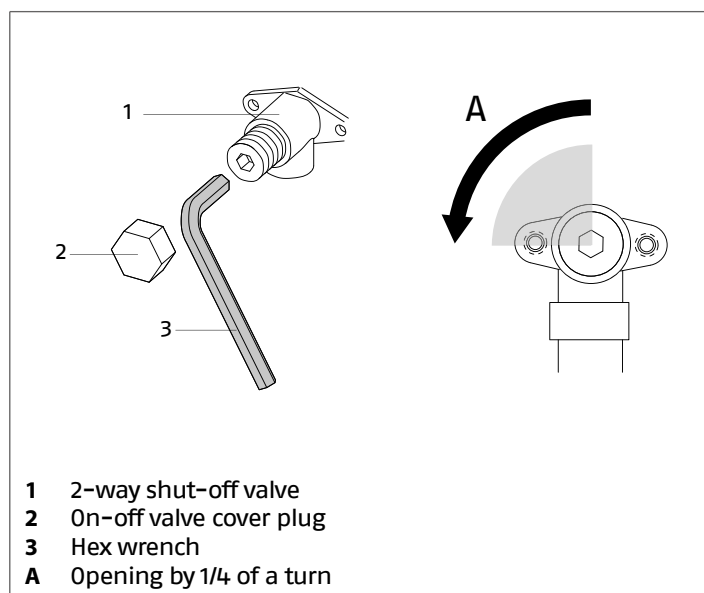

- open the 2-way shut-off valve by a quarter of a turn
- close it after 6 seconds so as to allow a small quantity of refrigerant into the circuit
- detect the leak using a solution of water and soap

## INSTALLATION

- fix the leak
- recreate the pneumatic vacuum

**⚠** Take the necessary safety precautions for the system refrigerant.

**⊘** It is forbidden to carry out welding operations with refrigerant inside the cooling circuit. If necessary, the refrigerant must be recovered and the circuit must be cleaned with nitrogen without oxygen.

**⊘** It is forbidden to use detergents containing chlorine because it could react with the refrigerant and corrode the copper pipes.

### If the pressure has not risen again:

- remove the tube of the pressure gauge unit from the service connection on the 3-way shut-off valve

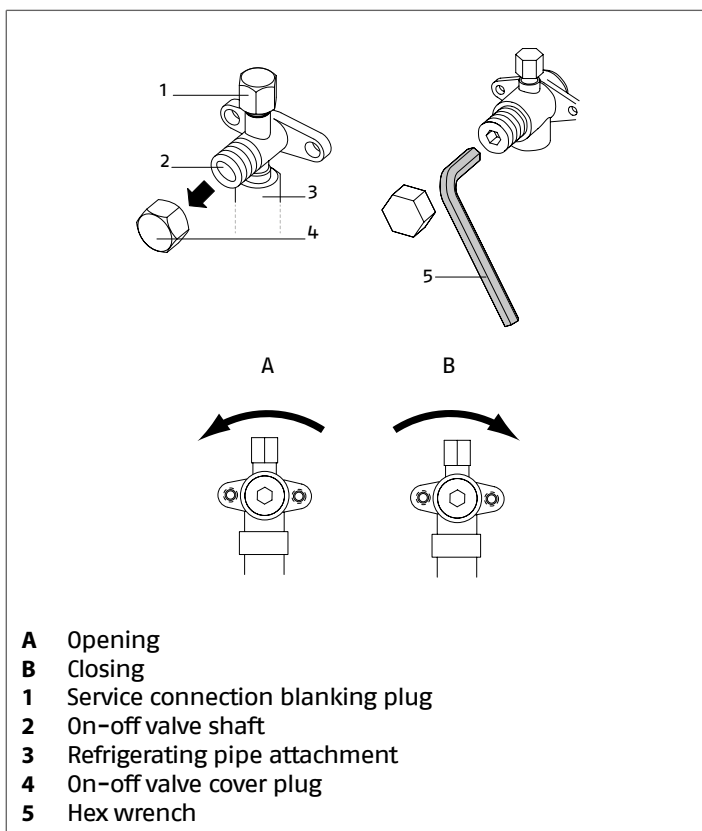

- fully open the unit shut-off valves
- refit the valve covering plug

**⚠** Carefully check for absence of leakages from the closing point of the plug.

**⚠** Do not force beyond the stop point to prevent damaging the shaft and causing leakage as a consequence.

**⚠** Once the check has been completed, remove any residues of the water-soap solution.

**⚠** Do not use the same vacuum pump with different refrigerants.

**⚠** The vacuum pump requires regular maintenance and the oil's clarity must also be checked.

**⚠** After having created the vacuum and established the electric connections, proceed with the additional refrigerant charge (see chapter "Additional refrigerant charge" p. 22).

## 2.11 Wiring diagram

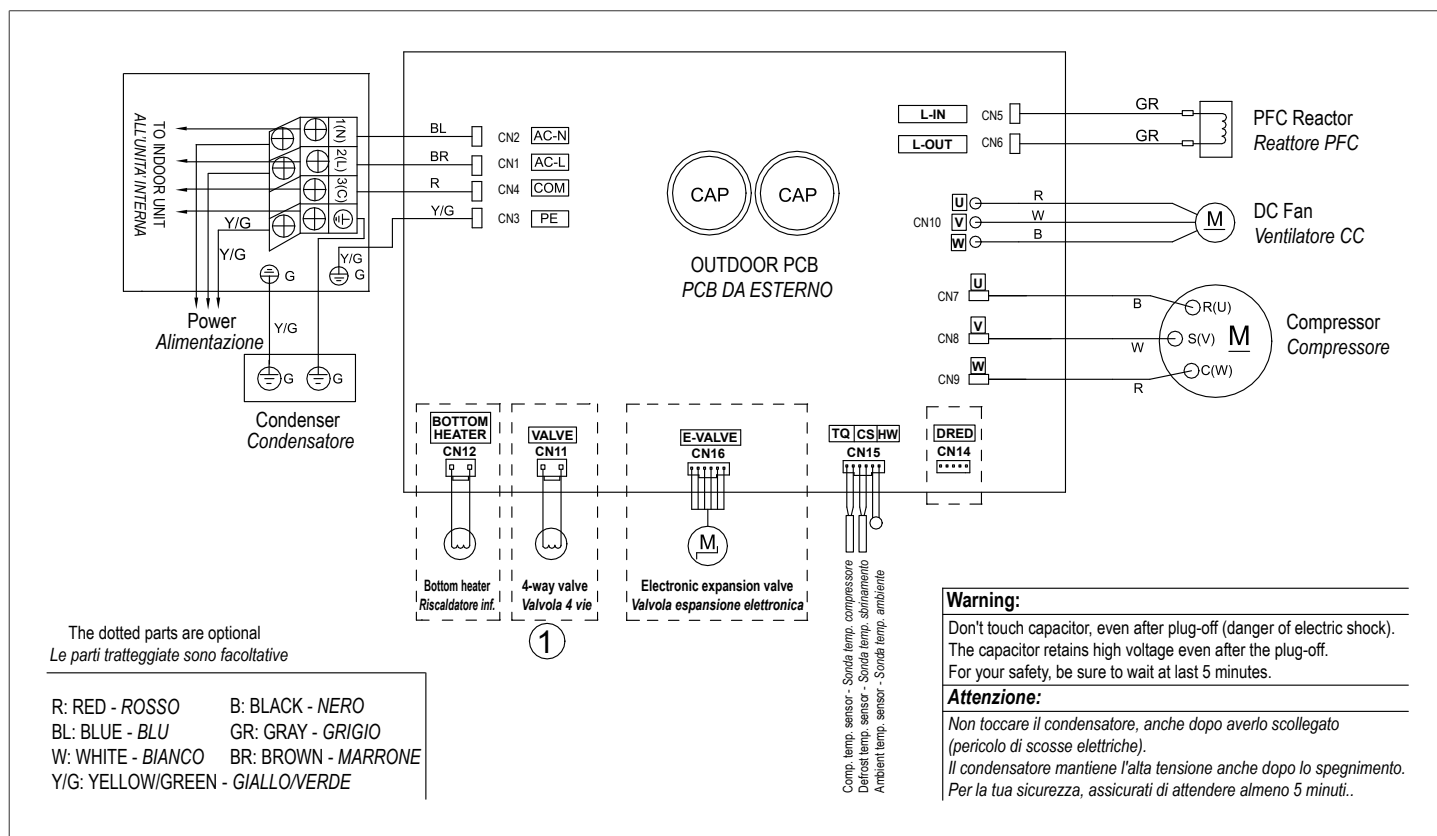

## 2.12 Electrical connection

**AARIA START N** It leaves the factory completely wired, and only requires a connection to the electrical power grid, the installation of a padlockable disconnecting switch, and a connection to the indoor unit.

**⚠** The unit must be powered with a separate electric circuit.

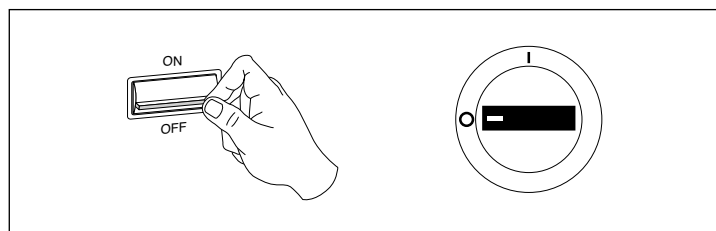
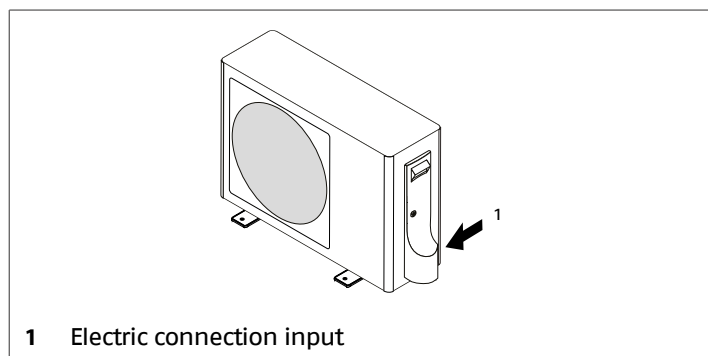

– position the system's main switch in the "OFF" position.

**⚠** Wait 10 minutes before touching the device electric components.

To access the terminal board:

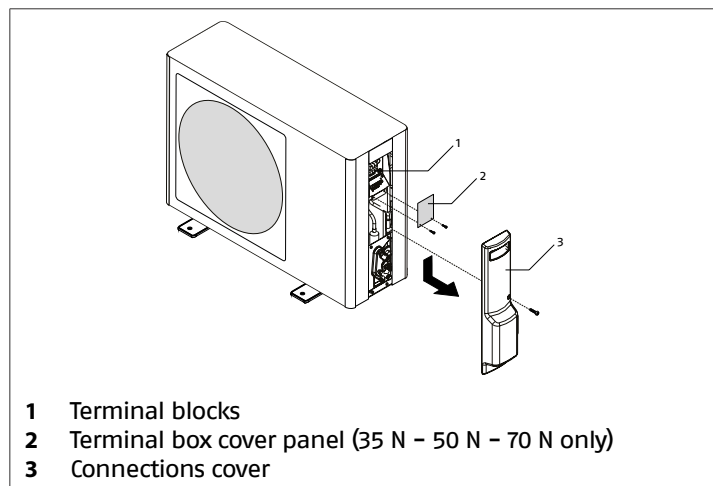

- unscrew the fastening screw
- push down the connection covering panel
- remove the connection covering panel
- unscrew the fastening screws
- remove the terminal board cover panel

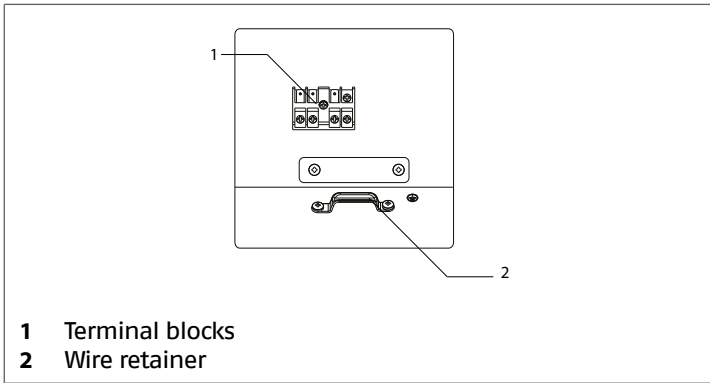

- remove the wire retainer
- make electrical connections according to the diagrams below

**MODEL 25 N - 35 N - 50 N - 70 N**

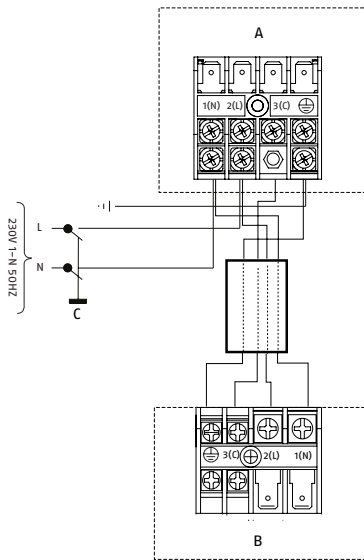

- A** Outdoor unit  
**B** Indoor unit  
**C** System main switch

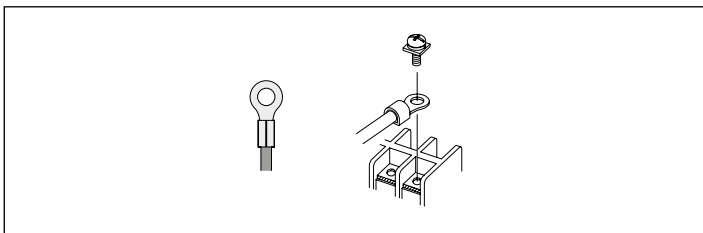

**⚠** It is compulsory to use ring crimp terminals to connect to the terminal board.

For the sizing of the electrical power cables and safety devices, use the following table:

Riello model		25 N	35 N	50 N	70 N
<b>Electrical characteristics</b>					
Protection factor	IP	X4			
Protection against short circuit	A	20,00	25,00		
Protection against overcurrent	A	10,00	13,00	15,00	
Ground protection	A	20	25		

Riello model		25 N	35 N	50 N	70 N
Residual current	mA	30,00			
Starting current	A	1,40		2,30	2,60
Power cable	Type	H07RN-F			
Power cable	n. x mm <sup>2</sup>	3 x 1	3 x 1,5		
Signal cable	n. x mm <sup>2</sup>	4 x 1			

**⚠** The cable sections specified in the table are minimum requirements. The correct size must be calculated taking into account the actual length, the type of routing and other conditions set by the existing regulations.

- fasten the wires with the wire retainer
- complete the electric connections and refit all components by performing the described operations in reverse order

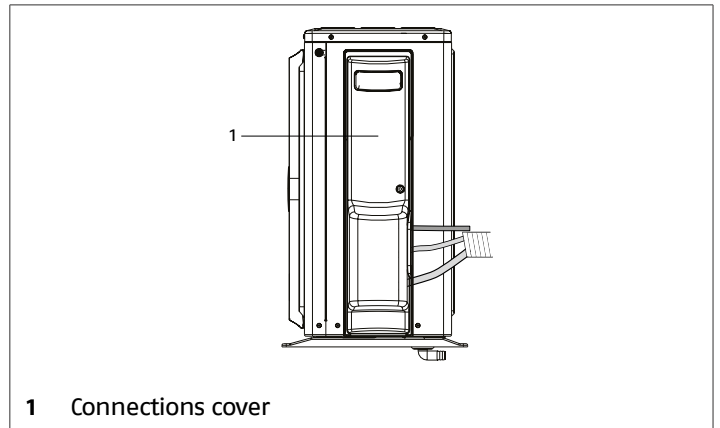

**Check that:**

- the characteristics of the power network are suitable for the device usage values
- the power supply voltage corresponds to the nominal value +/- 10%, with a maximum phase imbalance of 3%
- all of the power network disconnect devices must be equipped with contact openings (3 mm) in order to allow for complete disconnection, in accordance with the conditions required

**Mandatory items:**

- have an omnipolar magneto-thermal circuit breaker and a disconnecting switch compliant with the IEC-EN Standards (contact opening of at least 3 mm), with adequate breaking power and differential protection, installed near the equipment
- connect the device to a properly functioning earthing system
- make sure that the electrical power supply system is compliant with the current national safety standards
- make sure that the power supply line impedance is consistent with the unit's power consumption, as indicated on the unit's data plate
- for any electrical intervention, always refer to the wiring diagrams contained within this booklet
- take anti-static precautions in case of weather conditions where humidity is less than 40%

**⚠** Electric connections shall be made in compliance with national regulations.

**⚠** Avoid placing the connection cables less than 1 metre away from radio and video systems.

**⚠** Avoid using mobile phones.

- ⊖ It is forbidden to earth the device together with pipes, lightning conductors or the earthing system of a telephone line. Using an improper earthing system can cause electric shocks.
- ⊖ It is forbidden to connect other devices in parallel to the unit.

### 3 COMMISSIONING AND MAINTENANCE

#### 3.1 Preparation for first commissioning

Prior to commissioning, it is necessary to check that:

- all the safety conditions have been met
- installation distances and gaps have been respected
- the electrical connections have been properly completed
- power supply values are correct.
- the earthing has been carried out correctly
- all the connections have been properly tightened
- the shut-off valves are open

**⚠** The device must always be powered electrically in order to allow for the compressor's oil to be properly pre-heated.

**If the device is installed in very cold areas, the device should be under voltage for at least 12 hours before starting it up for the first time.**

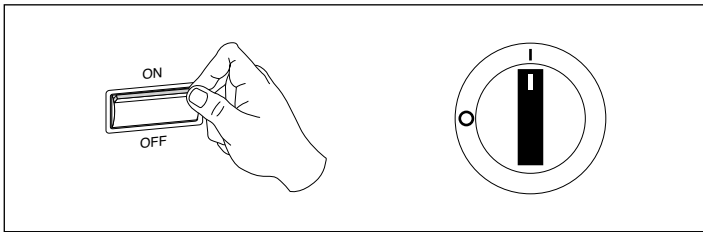

- position the system's main switch in the "ON" position.

#### 3.2 Putting into service

After having completed all the operations required to prepare for first commissioning, do the following to activate the device:

- follow the instructions given in the manual of the indoor unit that you are installing

**⚠** The unit has an automatic restart function after power failure.

**⚠** Keep the leak finder on and close to the unit so that it signals any refrigerant leak.

**⚠** Use an electronic leak finder properly calibrated for the system refrigerant.

**⊘** It is forbidden to use leak finders with halogen lamps.

#### Checks during and after the first commissioning

After starting the unit, leave it running for 30 minutes and then check that:

- the working pressures are correct
- the air temperature difference between intake and supply air in the indoor unit is correct
- the current consumed by the compressor is less than the maximum permitted
- the device is operating under the recommended operating conditions
- the unit is able to stop and start up again

**⚠** Should any of the above-listed controls have problems: turn the device off and call the Technical Service immediately.

**⚠** Do not touch the device pipes to prevent potential burns.

**⚠** Take anti-static precautions in case of weather conditions where humidity is less than 40%.

**⚠** Avoid using mobile phones.

#### Additional refrigerant charge

The units are supplied with a sufficient amount of refrigerant gas for a pre-set length of the connection pipes.

An additional refrigerant charge is needed if such length is exceeded.

The pre-set values are detailed in the following table:

Riello model		25 N	35 N	50 N	70 N
Maximum length with standard charge	m	5	5	7	7
Additional charge	g/m	20	20	20	20

**⚠** The device must be earthed before performing the additional charge.

To perform the additional charge:

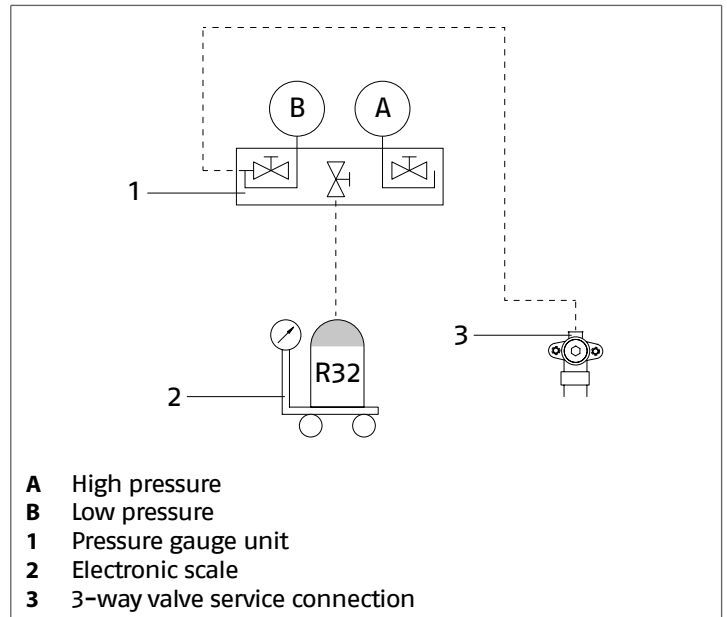

- connect the refrigerant cylinder to the pressure gauge unit
- connect the charging tube to the service connection on the 3-way shut-off valve
- remove the air from the charging tube
- charge the refrigerant with an electronic scale
- disconnect the charging tube from the service valve
- refit the three-way valve closing plug

**⚠** Carefully check for absence of leakages from the closing point of the plug.

**⚠** Do not force beyond the stop point to prevent damaging the shaft and causing leakage as a consequence.

**⚠** Use equipment suitable for the system refrigerant.

**⚠** Use only the system refrigerant.

- ⚠** Any gas leaks indoors can generate toxic gases if they come into contact with naked flames or high temperature bodies, in case of leaks, please air the rooms thoroughly.
- ⚠** Take anti-static precautions in case of weather conditions where humidity is less than 40%.
- ⚠** Avoid using mobile phones.

### 3.2.1 Refrigerant label

In base alla Normativa CE n. 517/2014 su determinati gas fluorurati ad effetto serra, è obbligatorio indicare la quantità totale di refrigerante presente sistema installato. Tale informazione è presente nella targhetta tecnica presente nell'unità esterna.

<p>QUESTO APPARECCHIO CONTIENE GAS AD EFFETTO SERRA COPERTI DAL PROTOCOLLO DI KYOTO.</p> <p>È VIETATO DISPERDERE IL GAS R32 DIRETTAMENTE IN ATMOSFERA.</p> <p><small> Istruzioni per compilare l'Etichetta "F-Gas Label":          1- Adattare le quantità all'installazione con richiesta ineditabile          2- Collocare l'adesivo plastico di protezione (segnato con il manuale)          3- Peso equivalente CO2 del sistema in tonnellate = Carica totale in kg / 1000 x GWP</small></p>	<p>INFORMAZIONI SUL REFRIGERANTE</p> <table border="1"> <tr> <td>Refrigerante</td> <td>: R32</td> <td></td> </tr> <tr> <td>GWP</td> <td>: 675</td> <td></td> </tr> <tr> <td>Carica di fabbrica (vedi etichetta tecnica)</td> <td>: </td> <td>kg A</td> </tr> <tr> <td>Carica addizionale</td> <td>: </td> <td>kg B</td> </tr> <tr> <td>Carica totale</td> <td>: </td> <td>kg C</td> </tr> <tr> <td>Peso equivalente CO2</td> <td>: </td> <td>t D</td> </tr> </table>	Refrigerante	: R32		GWP	: 675		Carica di fabbrica (vedi etichetta tecnica)	:	kg A	Carica addizionale	:	kg B	Carica totale	:	kg C	Peso equivalente CO2	:	t D
Refrigerante	: R32																		
GWP	: 675																		
Carica di fabbrica (vedi etichetta tecnica)	:	kg A																	
Carica addizionale	:	kg B																	
Carica totale	:	kg C																	
Peso equivalente CO2	:	t D																	

**A** Standard charge  
**B** Additional charge  
**C** Total charge  
**D** Equivalent total weight of CO2

To write the tag:

- note the quantity onto the label with indelible ink
- place the refrigerant gas label on the outdoor unit
- ⚠** This unit contains fluorinated greenhouse gases covered by the Kyoto protocol. Maintenance and disposal activities must be carried out exclusively by skilled personnel.
- ⚠** Global warming potential of the R32 refrigerant gas: GWP=675
- ⚠** If necessary, the refrigerant must be recovered and not dispersed into the environment.
- ⊖** It is forbidden to disperse the refrigerant into the environment.

### 3.3 Ordinary maintenance

Routine maintenance is fundamental for keeping the equipment efficient, safe and reliable. It can be performed periodically by the Technical Support Service, whose staff is technically qualified and can use genuine spare parts, if necessary.

- ⚠** For units installed in a seaside environment, the maintenance intervals shall be halved.
- ⚠** Original conditions must be restored after performing the required maintenance operations.
- ⚠** All described operations MUST be carried out under the following conditions:
  - cold device
  - device NOT supplied with electric power
  - suitable personal protection equipment

- ⊖** Do not open the access covers and carry out technical or cleaning activities before disconnecting the unit from the power grid by positioning the system's main switch in the "OFF" position.

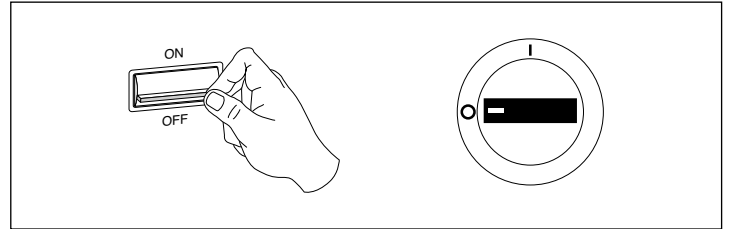

- position the system's main switch in the "OFF" position.

- ⚠** Wait 10 minutes before touching the device electric components.
- ⚠** Check with a tester that the voltage between the power supply connectors of the main electronic board is lower than 10 Vdc.

### Yearly operations

The annual maintenance plan includes the following checks:

- power supply voltage
- electric connection tightening
- status of cooling and hydraulic joint
- finned coil cleaning
- electric absorption
- fan grille cleaning

### Cleaning the heat exchanger fins

The thermal exchange bank must be cleaned with compressed air.

Cleaning must be carried out at least once a year, according to the location of the unit, as dirt accumulating between the fins narrows the passage section and reduces the exchange capability.

- check the alignment of the bank's aluminium fins and, if necessary, straighten them with the appropriate comb
- check that the condensate discharge pipe is clean

- ⚠** Do not use any means to accelerate the defrosting.

- ⚠** Do not use systems different from the ones indicated in this manual.

### Emptying of the evaporator

This operation may be necessary to perform reparations on the low pressure side (evaporator), the device reallocation or the replacement of the indoor unit without losing the whole refrigerant charge.

Proceed as follows:

- remove the covering plug from the shut-off valve
- check that the three-way shut-off valve is fully open
- let the device operate in cooling mode for 10 - 15 minutes
- stop the device for about 3 minutes
- connect the charging tube of the pressure gauge unit to the three-way valve service connection on gas side
- vent the air from the charging tube
- close the two-way shut-off valve on liquid side
- operate the equipment in cooling mode until pressure gauge reads a suction pressure of approx. -1 MPa

- close the three-way shut-off valve on gas side
- stop the unit
- disconnect the pressure gauge unit
- refit the valve covering plug

**⚠** Carefully check for absence of leakages from the closing point of the plug.

### 3.4 Operation signal and alarms

Signals are displayed by means of LEDs on the unit main electronic board.

Proceed as follows to access the filters:

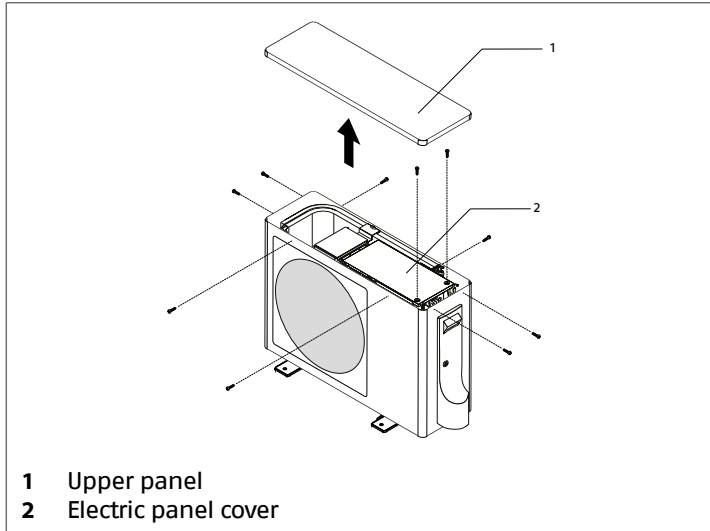

- unscrew the fastening screws
- remove the top panel
- unscrew the fastening screws
- remove the electric panel cover

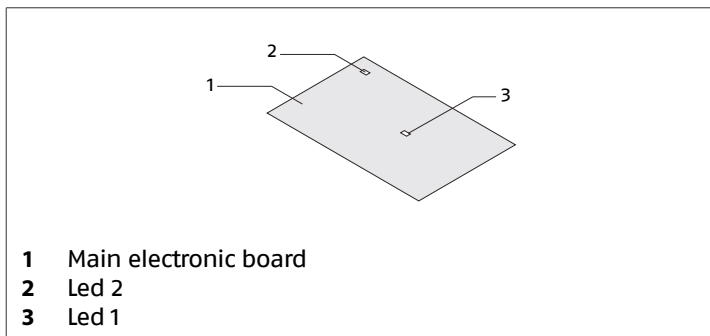

The unit operation is signalled with LED 2.

Led 2	Description
On	Indicates that the unit is supplied with electricity
Off	Indicates that the unit is not supplied with electricity

After the LED switches off:

**⚠** Wait 10 minutes before touching the device electric components.

**⚠** Check with a tester that the voltage between the power supply connectors of the main electronic board is lower than 10 Vdc.

In the presence of operating abnormalities, the unit is secured and blocked.

**⚠** Safety block can occur randomly.

**⚠** Wait for at least 10 minutes before restarting the unit.

**⚠** If the fault occurs again, an accurate check of the device components is required. Contact **RIELLO** Technical Support Service.

**⚠** Indoor units with display signal faults with an alphanumeric code. Consult the matching outdoor unit instruction booklet for the installer.

**Alarms table**

Faults are signalled by means of LED 1 blinking.

Led 1	Description	Remarks
1	External unit microprocessor fault	The unit resets after problem resolution
2	Power module fault	After 3 consecutive interventions in 10 minutes, the unit resets after problem resolution
3	Main electronic board protection against overcurrent	After 3 consecutive interventions in 30 minutes, the unit resets after problem resolution
4	Communication error between main board and power module	The alarm activates 4 minutes after the unit start The unit resets after problem resolution
5	Pressure protection	The unit resets after problem resolution
6	Wrong power supply voltage	The unit resets after problem resolution
7	Compressor lockout	After 3 consecutive interventions in 10 minutes, the unit resets after problem resolution
8	Overheat protection for compressor discharge	The unit resets automatically when the temperature drops under 110°C After 3 consecutive interventions in 30 minutes, the unit resets after problem resolution
9	Fan motor malfunction	After 3 consecutive interventions in 30 minutes, the unit resets after problem resolution
10	Pipe probe failure	The unit resets after problem resolution
11	Suction probe fault or suction overtemperature	The unit resets automatically when the temperature drops under 40°C or after problem resolution
12	External air probe fault	The unit resets after problem resolution
13	Discharge temperature sensor failure	The alarm activates 4 minutes after the unit start After 3 consecutive interventions in 30 minutes, the unit resets after problem resolution
15	Communication error between outdoor and indoor unit	The alarm activates 4 minutes after the unit start The unit resets after problem resolution
16	Lack of refrigerant	The alarm activates 5 minutes after the unit start After 2 consecutive interventions in 20 minutes, the unit resets after problem resolution
17	4-way valve malfunction	Alarm and stop if detect $T_m \leq 0$ last for 1min after compressor has started for 10 min in heating mode Not restorable if the alarm occurs 3 times in 1 hour, check the 4 way valve
18	Deviate from the normal for the compressor	The unit resets after problem resolution
19	Power module malfunction	After 3 consecutive interventions in 10 minutes, the unit resets after problem resolution
20	Electronic board overtemperature protection sensor fault	After 3 consecutive interventions in 1 hour, the unit resets after problem resolution
21	Internal unit overload	The unit resets after problem resolution
22	Internal unit anti-freeze protection	The alarm activates when the indoor unit heat exchanger probe is lower than the setpoint for 2 minutes The unit resets after problem resolution
24	Compressor motor overcurrent	The unit resets automatically
25	Overcurrent protection for single- phase of the compressor	The unit resets after problem resolution

#### 4 DISPOSAL

---

Packaging materials shall be disposed of separately so as to recover and recycle them. Refrigerant and oil must be recovered and not dispersed into the environment. At the end of its service life, the device shall be disposed of according to the existing legislation.

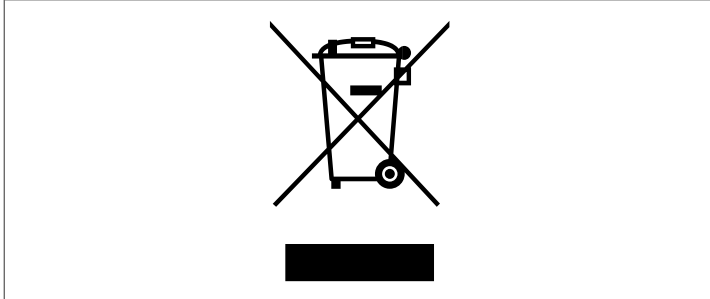

# RIELLO

RIELLO S.p.A. - 37045 Legnago (VR)  
tel. +39 0442 630111 - fax +39 0442 630371  
[www.riello.it](http://www.riello.it)

As the manufacturer is constantly improving its products, the aesthetic or dimensional features, the technical data, the equipment and accessories indicated could be subject to variations.