

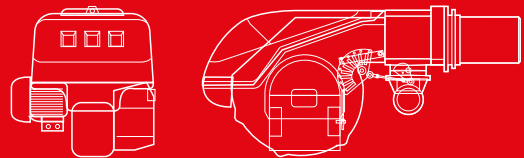

RS/M Series

Modulating Gas Burners

| | | |
|-------------|-----------------|----|
| RS 34/M MZ | 45/125 ÷ 390 | kW |
| RS 44/M MZ | 80/203 ÷ 550 | kW |
| RS 50/M MZ | 80/285 ÷ 630 | kW |
| RS 64/M MZ | 150/400 ÷ 850 | kW |
| RS 70/M | 150/470 ÷ 930 | kW |
| RS 100/M | 150/700 ÷ 1340 | kW |
| RS 130/M | 240/920 ÷ 1600 | kW |
| RS 150/M | 300/900 ÷ 1850 | kW |
| RS 190/M | 470/1279 ÷ 2290 | kW |
| RS 250/M MZ | 600/1250 ÷ 2650 | kW |



The RS/M burners series covers a firing range from 45 to 2650 kW, and it has been designed for use in low or medium temperature hot water boilers, hot air or steam boilers, diathermic oil boilers.

Operation can be "two stage progressive" or, alternatively, "modulating" with the installation of a PID logic regulator and respective probes.

RS/M burners series guarantees high efficiency levels in all the various applications, thus reducing fuel consumption and running costs.

The exclusive design ensures reduced dimensions, simple use and maintenance.

A wide range of accessories guarantees elevated working flexibility.

Technical Data

| MODEL | | RS 34/M MZ | RS 44/M MZ | RS 50/M MZ | RS 64/M MZ | RS 70/M |
|---------------------------------|---------------------|-----------------------------------------------------------------------------------------------------|--------------|--------------|---------------|------------------|
| Operation | | Modulating (with regulator and probes accessories) | | | | |
| Modulation ratio at max. output | | 6 ÷ 1 | | | | |
| Servomotor | type | SQN90 | | | | SQN31 |
| | run time s | 24 | | | | 42 |
| Heat output | kW | 45/125 ÷ 390 | 80/203 ÷ 550 | 80/285 ÷ 630 | 150/400 ÷ 850 | 150/470 ÷ 930 |
| | Mcal/h | 39/108 ÷ 336 | 69/175 ÷ 473 | 69/245 ÷ 542 | 130/345 ÷ 730 | 129/404 ÷ 800 |
| Working temperature | | °C min./max. 0/40 | | | | |
| FUEL/AIR DATA | | | | | | |
| G20 gas | net calorific value | kWh/Nm ³ 10 | | | | |
| | gas density | kg/Nm ³ 0,71 | | | | |
| | gas delivery | 7/13 ÷ 39 | 10/20 ÷ 55 | 8,5/29 ÷ 58 | 15/40 ÷ 85 | 13,5/46,5 ÷ 81,4 |
| G25 gas | net calorific value | kWh/Nm ³ 8,6 | | | | |
| | gas density | kg/Nm ³ 0,78 | | | | |
| | gas delivery | 8/15 ÷ 45 | 12/24 ÷ 64 | 10/34 ÷ 68 | 17/47 ÷ 99 | 16/54 ÷ 95 |
| LPG gas | net calorific value | kWh/Nm ³ 25,8 | | | | |
| | gas density | kg/Nm ³ 2,02 | | | | |
| | gas delivery | 3/5 ÷ 15 | 4/8 ÷ 21 | 4/11 ÷ 23 | 6/16 ÷ 33 | 5/18 ÷ 32 |
| Fan | | type (02) (02) (01) (02) (01) | | | | |
| Air temperature | | max °C 60 | | | | |
| ELECTRICAL DATA | | | | | | |
| Electrical supply | | Ph/Hz/V (04) (04) (06) (05) (05) (05) | | | | |
| Auxiliary electrical supply | | Ph/Hz/V (04) (04) (03) (03) (03) | | | | |
| Control box | | type RMG/M | | | | |
| Total electrical power | | kW 0,6 0,7 0,75 0,75 1,4 1,4 | | | | |
| Auxiliary electrical power | | kW 0,3 0,28 0,3 0,12 0,3 0,3 | | | | |
| Protection level | | IP 40 40 44 40 44 | | | | |
| Fan motor | electrical power | kW 0,3 0,42 0,45 0,65 1,1 1,1 | | | | |
| | rated current | A 3,2 3,5 2 - 1,4 3 - 1,7 4,8 - 2,8 4,8 - 2,8 | | | | |
| | start up current | A 15 17 14 - 10 13,8 - 8 22 - 13 33 - 19 | | | | |
| | protection level | IP 54 | | | | |
| Ignition transformer | | V1 - V2 230V - 1x15 kV 230V - 1x15 kV 230V - 1x8 kV 230V - 1x15 kV 230V-1x8 kV | | | | |
| | | I1 - I2 1A - 25 mA 1A - 25 mA 1A - 20 mA 1A - 25 mA 1A - 20 mA | | | | |
| Operation | | Intermittent (at least one stop every 24 h) - Continuous as optional (at least one stop every 72 h) | | | | |
| EMISSIONS | | | | | | |
| Noise levels | sound pressure | dB(A) 68 70 72 76 75 | | | | |
| | sound power | 79 81 83 87 86 | | | | |
| Gas G20 | CO emission | mg/kWh < 10 < 3 < 40 < 40 < 40 | | | | |
| | NOx emission | mg/kWh < 97 < 95 < 130 < 120 < 130 | | | | |
| APPROVAL | | | | | | |
| Directive | | 2006/42/EC - 2016/426/EU - 2014/30/EU - 2014/35/EU | | | | |
| Conforming to | | EN 676 | | | | |
| Certification | | CE 0085BR0378 CE 0085AQ0709 CE 0085BR0558 CE 0085AQ0708 | | | | |

- | | |
|--------------------------------------------|-----------------------------|
| (01) Centrifugal with reverse curve blades | (04) 1/50-60/220-230~(±10%) |
| (02) Centrifugal with forward curve blades | (05) 3/50/230-400~(±10%) |
| (03) 1/50/230~(±10%) | (06) 3/50-60/220-400~(±10%) |

Reference conditions:

Temperature: 20°C - Pressure: 1013.5 mbar - Altitude: 0 m a.s.l. - Sound pressure measured in manufacturer's combustion laboratory, with burner operating on test boiler and at maximum rated output. The sound power is measured with the "Free Field" method, as per EN 15036, and according to an "Accuracy: Category 3" measuring accuracy, as set out in EN ISO 3746.

| MODEL | | RS 100/M | RS 130/M | RS 150/M | RS 190/M | RS 250/M | |
|---------------------------------|---------------------------------------|--------------------------------------------------------------------------------------------------------|----------------|------------------------|-----------------|-----------------|-----------|
| Operation | | Modulating (with regulator and probes accessories) | | | | | |
| Modulation ratio at max. output | | 6 ÷ 1 | | | | | |
| Servomotor | type | SQN31 | | | | | |
| | run time s | 42 | | | | | |
| Heat output | kW | 150/700 ÷ 1340 | 240/920 ÷ 1600 | 300/900 ÷ 1850 | 470/1279 ÷ 2290 | 600/1250 ÷ 2650 | |
| | Mcal/h | 129/602 ÷ 1152 | 206/791 ÷ 1376 | 258/774 ÷ 1590 | 405/1100 ÷ 1970 | 516/1075 ÷ 2279 | |
| Working temperature | °C min./max. | 0/40 | | | | | |
| FUEL/AIR DATA | | | | | | | |
| G20 gas | net calorific value | 10 | | | | | |
| | gas density | 0,71 | | | | | |
| | gas delivery | 15/70 ÷ 116 | 16/93 ÷ 151 | 30/90 ÷ 185 | 47/128 ÷ 229 | 60/125 ÷ 265 | |
| G25 gas | net calorific value | 8,6 | | | | | |
| | gas density | 0,78 | | | | | |
| | gas delivery | 17/81 ÷ 135 | 19/108 ÷ 176 | 35/105 ÷ 215 | 55/149 ÷ 266 | 70/145 ÷ 308 | |
| LPG gas | net calorific value | 25,8 | | | | | |
| | gas density | 2,02 | | | | | |
| | gas delivery | 6/27 ÷ 45 | 6/36 ÷ 59 | 12/35 ÷ 72 | 18/50 ÷ 89 | 23/48 ÷ 103 | |
| Fan | type | (01) | (01) | (01) | (02) | (02) | |
| Air temperature | max °C | 60 | | | | | |
| ELECTRICAL DATA | | | | | | | |
| Electrical supply | Ph/Hz/V | (05) | (05) | (07) (08) | (05) | (07) (08) | |
| Auxiliary electrical supply | Ph/Hz/V | (03) | (03) | (03) | (03) | (03) | |
| Control box | type | RMG/M | | | | | |
| Total electrical power | kW | 1,8 | 2,6 | 4 | 5,5 | 6,5 | |
| Auxiliary electrical power | kW | 0,3 | 0,4 | 0,5 | 1,0 | 1,0 | |
| Protection level | IP | 44 | | | | | |
| Fan motor | electrical power | kW | 1,5 | 2,2 | 3,0 | 4,5 | 5,5 |
| | rated current | A | 5,9 - 3,4 | 8,8 - 5,1 | 10,2 5,9 | 15,8 - 9,1 | 12,3 21,3 |
| | start up current | A | 48 - 28 | 68 - 39 | 79 45,8 | 126 - 73 | 83 143 |
| | protection level | IP | 54 | | | | |
| Ignition transformer | V1 - V2 | 230V-1x8 kV | 230V-1x8 kV | 230V-1x8 kV | 230V-1x8 kV | 230V-1x15 kV | |
| | I1 - I2 | 1A - 20 mA | 1A - 20 mA | 1A - 20 mA | 1A - 20 mA | 1A - 20 mA | |
| Operation | | Intermittent (at least one stop every 24 h) - Continuous as optional (at least one stop every 72 h) | | | | | |
| EMISSIONS | | | | | | | |
| Noise levels | sound pressure | dB (A) | 77 | 78,5 | 83,1 | 83,1 | 83 |
| | sound power | W | -- | | | | |
| Gas | CO emission | mg/kWh | < 40 | | | | |
| | NOx emission | mg/kWh | < 130 | < 130 | < 130 | < 130 | < 120 |
| APPROVAL | | | | | | | |
| Directive | | 2006/42/EC - 2016/426/EU - 2014/30/EU - 2014/35/EU | | | | | |
| Conforming to | | EN 676 | | | | | |
| Certification | | CE 0085AQ0708 | in progress | | CE 0085AT0042 | CE 0085BS0114 | |
| (01) | Centrifugal with reverse curve blades | | (05) | 3/50/230-400~(±10%) | | | |
| (02) | Centrifugal with forward curve blades | | (06) | 3/50-60/220-400~(±10%) | | | |
| (03) | 1/50/230~(±10%) | | (07) | 3/50/400~(±10%) | | | |
| (04) | 1/50-60/220-230~(±10%) | | (08) | 3/50/230~(±10%) | | | |

Reference conditions:

Temperature: 20°C - Pressure: 1013.5 mbar - Altitude: 0 m a.s.l. - Sound pressure measured in manufacturer's combustion laboratory, with burner operating on test boiler and at maximum rated output. The sound power is measured with the "Free Field" method, as per EN 15036, and according to an "Accuracy: Category 3" measuring accuracy, as set out in EN ISO 3746.

Firing Rates

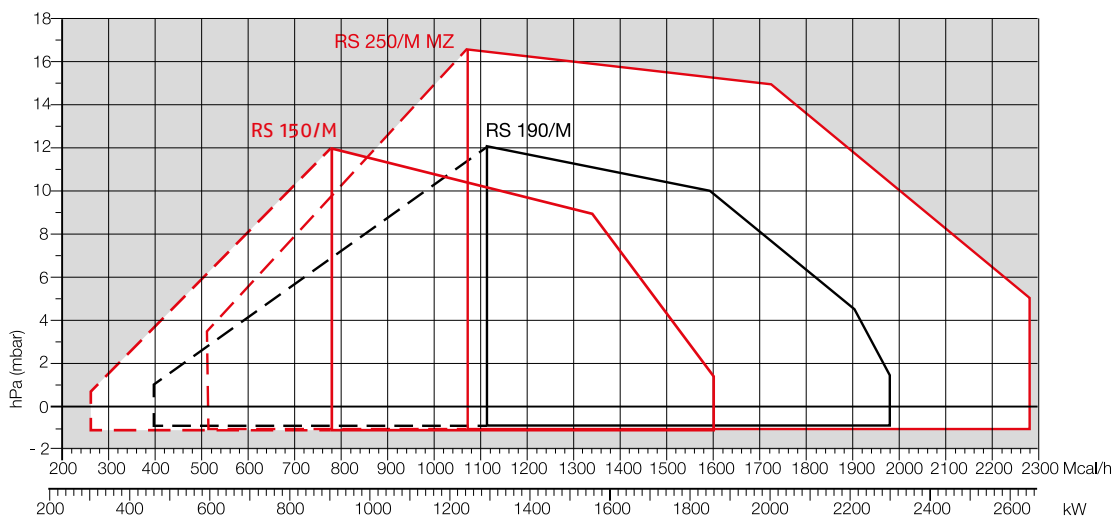
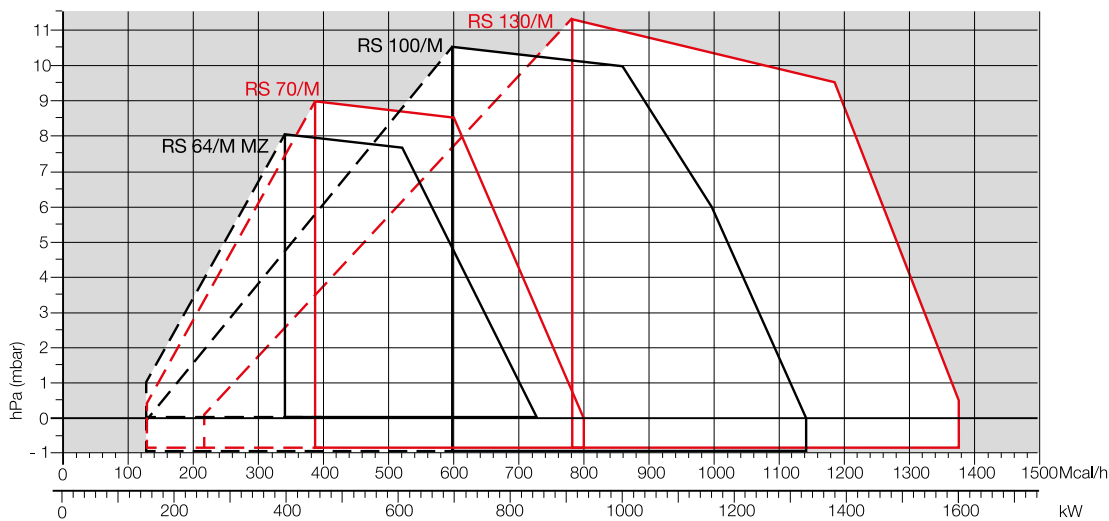
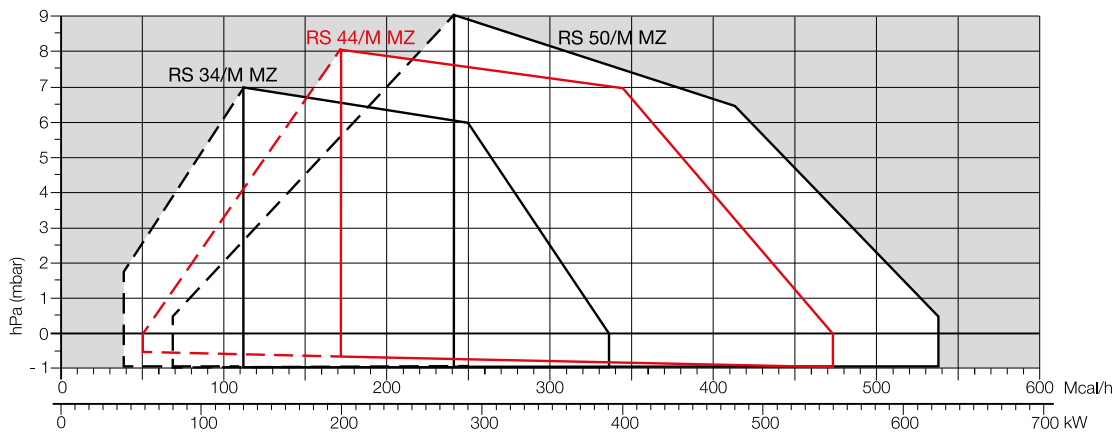

□ Useful working field for choosing the burner

▤▤ Modulation range

Test conditions conforming to EN 676:

Temperature: 20°C

Pressure: 1013,5 mbar

Altitude: 0 m a.s.l.

Gas train

GAS TRAIN DESIGNATION

- Series: MB
 MBC
 DMV
 DMV12
 VGD
 CB
 CBH
 MV
 CG

| Size: | 405 | 407 | 410 | 412 | 415 | 420 | | | | | | | |
|-------|-----|-----|-----|-----|-----|------|-----|------|------|-------|-------|-------|--|
| | | 65 | 120 | 300 | 700 | 1200 | - | 1900 | 3100 | 5000 | | | |
| | 505 | 507 | 510 | 512 | - | 520 | 525 | 5065 | 5080 | 50100 | 50125 | 50150 | |
| 10 | 15 | 20 | 32 | 40 | - | 50 | - | 65 | 80 | 100 | 125 | 150 | |
| | | 120 | 220 | | | | | | | | | | |

- Operation: /S only ON-OFF function
 /1 stage mode opening
 /2 2nd stage mode opening
 /P 1st stage mode opening with air/gas proportional regulator

- Leak detection control: - 0
 CT leak detection control device installed on the gas train
 CQ equipped with pressure switch for leak detection control

- Joint type: R threaded joint
 F standard flange ISO
 F1 square flange BS1
 F2 square flange BS2
 F3 square flange BS3 - BS4

- Electrical connection: T Terminals - Terminal strip
 SD Domestic plug
 SM Medium voltage plug

- Standard output pressure range: - without pressure governor
 0 with governor and air/gas proportional pressure
 2 with governor and output pressure up to 20 mbar
 3 with governor and output pressure up to 30 mbar
 4 with governor and output pressure up to 40 mbar
 5 with governor and output pressure up to 50 mbar
 6 with governor and output pressure up to 60 mbar
 8 with governor and output pressure up to 80 mbar
 15 with governor and output pressure up to 150 mbar

- Valve control: 0 shared
 2 separate

| | | | | | | | |
|----|------|----|----|---|----|---|---|
| CB | 5065 | /1 | CT | F | SM | 3 | 0 |
|----|------|----|----|---|----|---|---|

BASIC DESIGNATION

EXTENDED DESIGNATION

GAS TRAINS

The burners are fitted with a butterfly valve to regulate the fuel, controlled by a variable profile cam servomotor. Fuel can be supplied either from the right or left hand sides. A maximum gas pressure switch stops the burner in case of excess pressure in the fuel line (as accessory on RS 34-44/M MZ). The gas train can be selected to best fit system requirements depending on the fuel output and pressure in the supply line.



Example of the variable profile cam on RS 34-44/M MZ burners.



Example of the variable profile cam on RS 250/M MZ burners.

MB "THREADED"

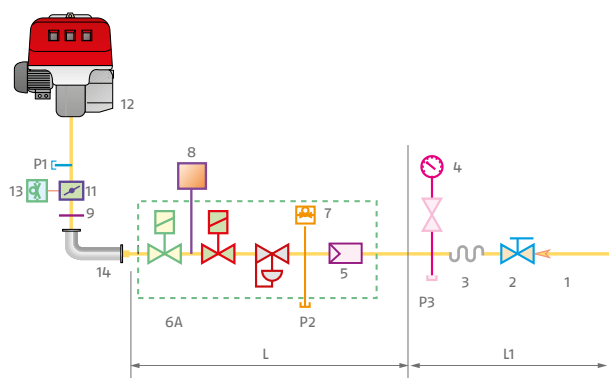

| | |
|----|----------------------------------------------------------------------------------------------|
| 1 | Gas input pipework |
| 2 | Manual valve |
| 3 | Anti-vibration joint |
| 4 | Pressure gauge with pushbutton cock |
| 5 | Filter |
| 6A | Includes: |
| | - filter |
| | - operation valve |
| | - safety valve |
| | - pressure adjuster |
| 7 | Minimum gas pressure switch |
| 8 | Leak detection device, supplied as an accessory or incorporated, based on the gas train code |
| 9 | Gasket, for "flanged" versions only |
| 10 | Pressure adjuster |
| 11 | Gas adjuster butterfly valve |
| 12 | Burner |
| 13 | Maximum gas pressure switch |
| 14 | Gas train-burner adaptor, supplied separately |
| P1 | Combustion head pressure |
| P2 | Upstream pressure of valves |
| P3 | Upstream pressure of the filter |
| L | Gas train supplied separately, with the code given in the table |
| L1 | Installer's responsibility |

MBC "THREADED"

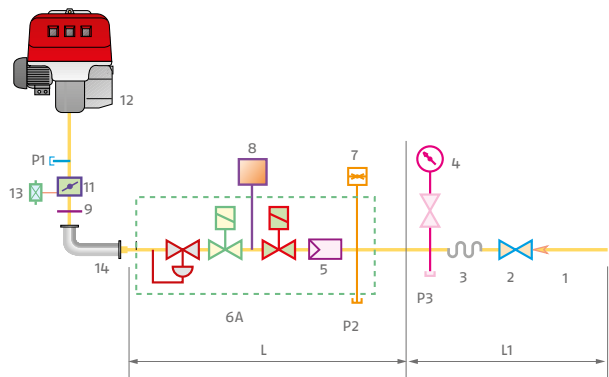

MBC "FLANGED"

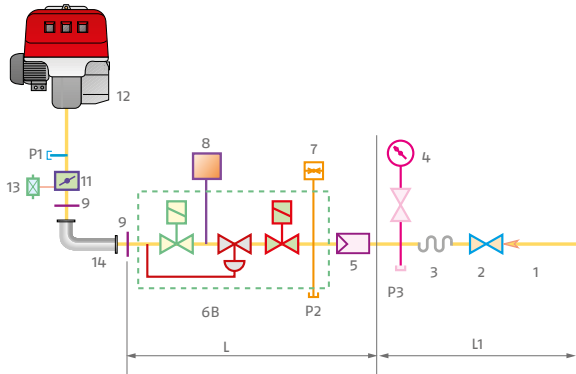

| | |
|----|----------------------------------------------------------------------------------------------|
| 1 | Gas input pipework |
| 2 | Manual valve |
| 3 | Anti-vibration joint |
| 4 | Pressure gauge with pushbutton cock |
| 5 | Filter |
| 6B | Includes: - operation valve - safety valve - pressure adjuster |
| 6C | Includes: - operation valve - safety valve |
| 6D | Includes: - operation valve - safety valve |
| 7 | Minimum gas pressure switch |
| 8 | Leak detection device, supplied as an accessory or incorporated, based on the gas train code |
| 9 | Gasket, for "flanged" versions only |
| 10 | Pressure adjuster |
| 11 | Gas adjuster butterfly valve |
| 12 | Burner |
| 13 | Maximum gas pressure switch |
| 14 | Gas train-burner adaptor, supplied separately |
| P1 | Combustion head pressure |
| P2 | Upstream pressure of valves |
| P3 | Upstream pressure of the filter |
| L | Gas train supplied separately, with the code given in the table |
| L1 | Installer's responsibility |

CB "FLANGED OR THREADED"

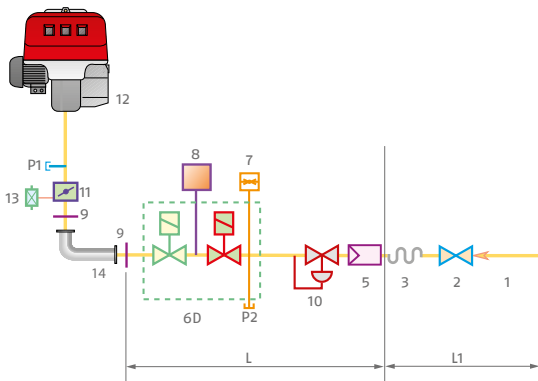

DMV "FLANGED OR THREADED"

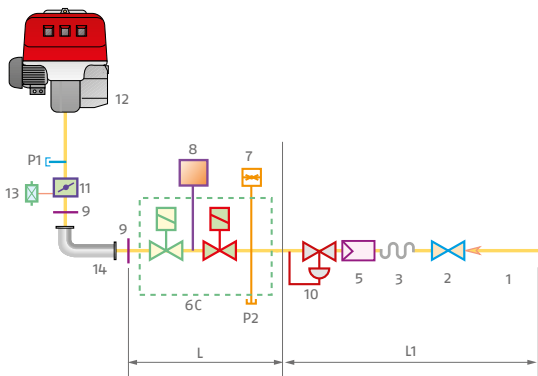

Gas trains are approved by standard EN 676 together with the burner.

The overall dimensions of the gas train depends on how they are constructed. The following table shows the maximum dimensions of the gas trains that can be fitted to RS/M burners, intake and outlet diameters and seal control if fitted.

Please note that the seal control can be installed as an accessory, if not already installed on the gas train. The maximum gas pressure of gas train "Multibloc" type is 360 mbar, and that one of gas train "Composed" type is 500 mbar. The range of pressure in the MULTIBLOC with flange can be modified choosing the stabiliser spring (see gas train accessory).

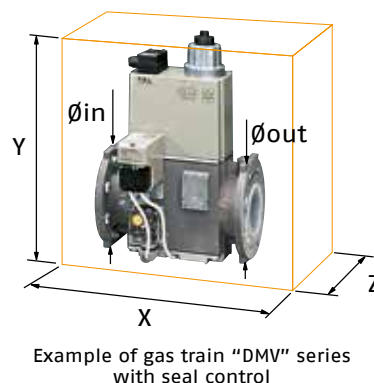
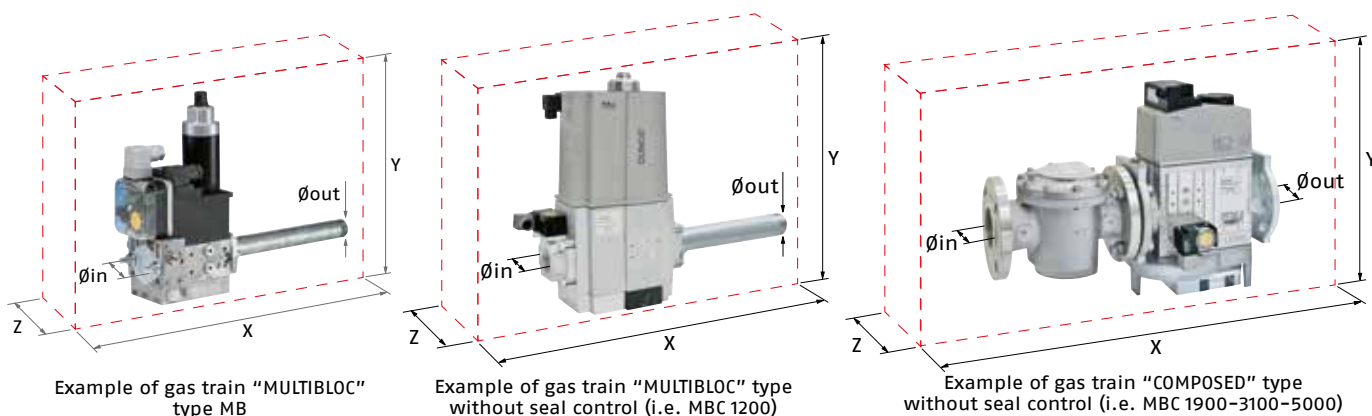

| GAS TRAIN | | | | | | |
|-------------------|-------------|-------------|--------------|-------------|-------------|-------------|
| MODEL | CODE | ∅ in | ∅ out | X mm | Y mm | Z mm |
| MB 405/1 - RT 20 | 3970500 | Rp 3/4" | Rp 3/4" | 371 | 186 | 92 |
| MB 407/1 - RT 20 | 3970553 | Rp 3/4" | Rp 3/4" | 371 | 196 | 92 |
| MB 407/1 - RT 52 | 3970599 | Rp 3/4" | Rp 3/4" | 371 | 196 | 92 |
| MB 407/1 - RSM 20 | 3970229 | Rp 3/4" | Rp 3/4" | 371 | 196 | 92 |
| MB 410/1 - RT 52 | 3970258 | Rp 1" 1/2 | Rp 1" 1/2 | 405 | 217 | 116 |
| MB 410/1 - RT 20 | 3970554 | Rp 3/4" | Rp 3/4" | 405 | 217 | 116 |
| MB 410/1 - RT 52 | 3970600 | Rp 3/4" | Rp 3/4" | 405 | 217 | 116 |
| MB 410/1 - RSM 20 | 3970230 | Rp 3/4" | Rp 3/4" | 405 | 221 | 116 |
| MB 412/1 - RT 52 | 3970256 | Rp 1" 1/2 | Rp 1" 1/2 | 433 | 217 | 116 |
| MB 412/1 - RT 20 | 3970144 | Rp 1" 1/2 | Rp 1" 1/2 | 433 | 217 | 116 |
| MB 412/1 CT RT 20 | 3970197 | Rp 1" 1/2 | Rp 1" 1/2 | 523 | 217 | 116 |
| MB 412/1 - RSM 20 | 3970231 | Rp 1" 1/2 | Rp 1" 1/2 | 433 | 217 | 116 |
| MB 415/1 - RT 30 | 3970180 | Rp 1-1/2" | Rp 1-1/2" | 523 | 250 | 100 |
| MB 415/1 CT RT 30 | 3970198 | Rp 1-1/2" | Rp 1-1/2" | 523 | 250 | 229 |
| MB 415/1 - RT 52 | 3970250 | Rp 1-1/2" | Rp 1-1/2" | 523 | 250 | 100 |
| MB 415/1 CT RT 52 | 3970253 | Rp 1-1/2" | Rp 1-1/2" | 523 | 250 | 229 |
| MB 415/1 RSM 30 | 3970232 | Rp 1-1/2" | Rp 1-1/2" | 523 | 250 | 100 |
| MB 420/1 RT 30 | 3970181 | Rp 2" | Rp 2" | 523 | 300 | 100 |
| MB 420/1 CT RT 30 | 3970182 | Rp 2" | Rp 2" | 523 | 300 | 229 |

GAS TRAIN

| MODEL | CODE | Ø in | Ø out | X mm | Y mm | Z mm |
|--------------------|---------|-------|-------|------|------|------|
| MB 420/1 RT 52 | 3970257 | Rp 2" | Rp 2" | 523 | 300 | 100 |
| MB 420/1 CT RT 52 | 3970252 | Rp 2" | Rp 2" | 523 | 300 | 229 |
| MB 420/1 RSM 30 | 3970233 | Rp 2" | Rp 2" | 523 | 300 | 100 |
| MB 420/1 CT RSM 30 | 3970234 | Rp 2" | Rp 2" | 523 | 300 | 229 |

GAS TRAIN

| MODEL | CODE | Ø in | Ø out | X mm | Y mm | Z mm |
|----------------------|---------|--------|--------|------|------|------|
| MBC 1200/1 - RSM 60 | 3970221 | Rp 2" | Rp 2" | 528 | 424 | 161 |
| MBC 1200/1 CT RSM 60 | 3970225 | Rp 2" | Rp 2" | 528 | 424 | 290 |
| MBC 1900/1 - FSM 40 | 3970222 | DN 65 | DN 65 | 613 | 430 | 237 |
| MBC 1900/1 CT FSM 40 | 3970226 | DN 65 | DN 65 | 613 | 430 | 298 |
| MBC 3100/1 - FSM 40 | 3970223 | DN 80 | DN 80 | 633 | 500 | 240 |
| MBC 3100/1 CT FSM 40 | 3970227 | DN 80 | DN 80 | 633 | 500 | 319 |
| MBC 5000/1 - FSM 80 | 3970224 | DN 100 | DN 100 | 733 | 576 | 280 |
| MBC 5000/1 CT FSM 80 | 3970228 | DN 100 | DN 100 | 733 | 576 | 348 |

GAS TRAIN

| MODEL | CODE | Ø in | Ø out | X mm | Y mm | Z mm |
|----------------------|----------|-----------|-----------|------|------|------|
| CB 512/1 - RSM 30 | 3970145 | Rp 1-1/2" | Rp 1-1/2" | 891 | 261 | 245 |
| CB 512/1 - CT RSM 30 | 20045589 | Rp 1-1/2" | Rp 1-1/2" | 891 | 261 | 245 |
| CB 520/1 - RSM 30 | 3970146 | Rp 2" | Rp 2" | 986 | 328 | 255 |
| CB 520/1 - CT RSM 30 | 3970160 | Rp 2" | Rp 2" | 986 | 328 | 255 |
| CB 525/1 - RSM 30 | 20044659 | Rp 2" | Rp 2" | 1025 | 356 | 285 |
| CB 525/1 - CT RSM 30 | 20044660 | Rp 2" | Rp 2" | 1025 | 356 | 285 |
| CB 5065/1 - FSM 30 | 3970147 | DN 65 | DN 65 | 906 | 356 | 285 |
| CB 5065/1 CT FSM 30 | 3970161 | DN 65 | DN 65 | 906 | 356 | 285 |
| CB 5080/1 - FSM 30 | 3970148 | DN 80 | DN 80 | 934 | 416 | 285 |
| CB 5080/1 CT FSM 30 | 3970162 | DN 80 | DN 80 | 934 | 416 | 285 |
| CB 50100/1 - FSM 30 | 3970149 | DN 100 | DN 100 | 1054 | 501 | 350 |
| CB 50100/1 CT FSM 30 | 3970163 | DN 100 | DN 100 | 1054 | 501 | 350 |
| CB 50125/1 - FSM 30 | 20015871 | DN 125 | DN 125 | 1164 | 780 | 400 |
| CB 50125/1 CT FSM 30 | 3970196 | DN 125 | DN 125 | 1164 | 780 | 400 |

GAS TRAIN

| MODEL | CODE | Ø in | Ø out | X mm | Y mm | Z mm |
|------------------------|----------|-----------|-----------|------|------|------|
| DMV 512/1 - RSM - 0 | 20043035 | Rp 1-1/2" | Rp 1-1/2" | 490 | 292 | 245 |
| DMV 512/1 - CT RSM - 0 | 20043036 | Rp 1-1/2" | Rp 1-1/2" | 490 | 292 | 245 |
| DMV 512/1 - CQ RSM - 2 | 20043037 | Rp 1-1/2" | Rp 1-1/2" | 490 | 292 | 245 |
| DMV 520/1 - RSM - 0 | 20043038 | Rp 2" | Rp 2" | 490 | 292 | 255 |
| DMV 520/1 CT RSM - 0 | 20043039 | Rp 2" | Rp 2" | 490 | 292 | 255 |
| DMV 520/1 CQ RSM - 2 | 20043040 | Rp 2" | Rp 2" | 490 | 292 | 255 |
| DMV 525/1 - RSM - 0 | 20043053 | Rp 2" | Rp 2" | 530 | 338 | 270 |
| DMV 525/1 CT RSM - 0 | 20043054 | Rp 2" | Rp 2" | 530 | 338 | 270 |
| DMV 525/1 CQ RSM - 2 | 20043055 | Rp 2" | Rp 2" | 530 | 338 | 270 |
| DMV 5065/1 - FSM - 0 | 20043041 | DN 65 | DN 65 | 290 | 338 | 270 |
| DMV 5065/1 CT FSM - 0 | 20043042 | DN 65 | DN 65 | 290 | 338 | 270 |
| DMV 5065/1 CQ FSM - 2 | 20043043 | DN 65 | DN 65 | 290 | 338 | 270 |
| DMV 5080/1 - FSM - 0 | 20043044 | DN 80 | DN 80 | 310 | 397 | 290 |
| DMV 5080/1 CT FSM - 0 | 20043045 | DN 80 | DN 80 | 310 | 397 | 290 |
| DMV 5080/1 CQ FSM - 2 | 20043046 | DN 80 | DN 80 | 310 | 397 | 290 |
| DMV 50100/1 - FSM - 0 | 20043047 | DN 100 | DN 100 | 350 | 449 | 307 |
| DMV 50100/1 CT FSM - 0 | 20043048 | DN 100 | DN 100 | 350 | 449 | 307 |
| DMV 50100/1 CQ FSM - 2 | 20043049 | DN 100 | DN 100 | 350 | 449 | 307 |
| DMV 50125/1 - FSM - 0 | 20043050 | DN 125 | DN 125 | 400 | 554 | 333 |
| DMV 50125/1 CT FSM - 0 | 20043051 | DN 125 | DN 125 | 400 | 554 | 333 |
| DMV 50125/1 CQ FSM - 2 | 20043052 | DN 125 | DN 125 | 400 | 554 | 333 |

Pressure Drop Diagram

The diagrams indicate the minimum pressure drop of the burners with the various gas trains that can be matched with them; at the value of these pressure drop add the combustion chamber pressure. The value thus calculated represents the minimum required input pressure to the gas train.

The minimum input gas pressure required is 15 mbar while burner operating. In particular, the pressure difference between gas train upstream and downstream has to remain always over pressure drop values indicated below.

RS 34/M (NATURAL GAS)

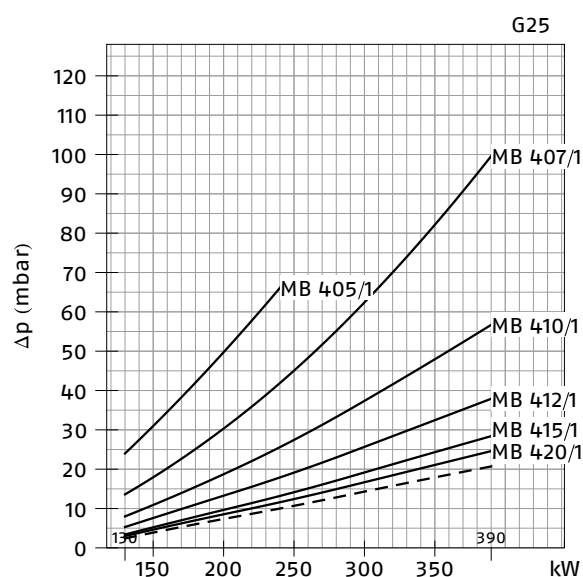
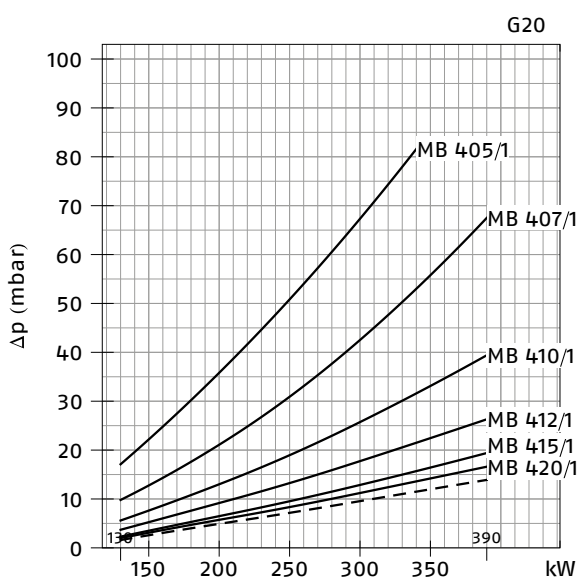

RS 34/M (NATURAL GAS)

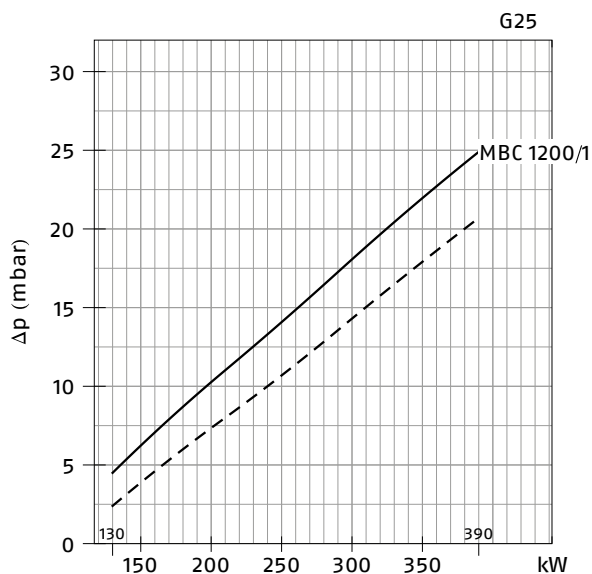
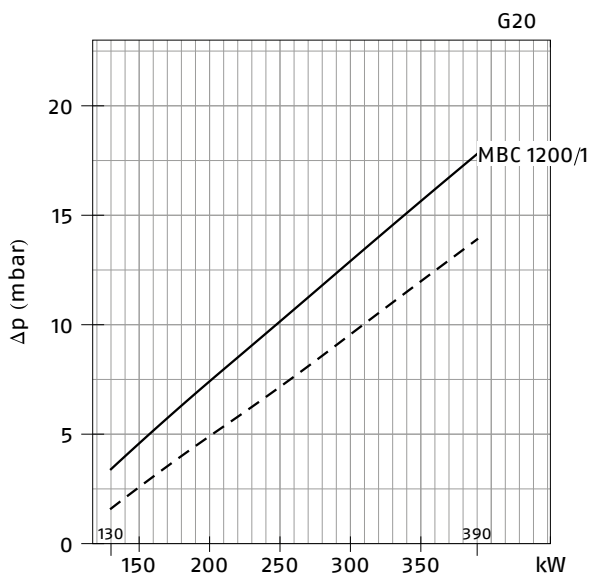

- Combustion head + gas butterfly valve + gas train
- - - Combustion head + gas butterfly valve

RS 34/M (NATURAL GAS)

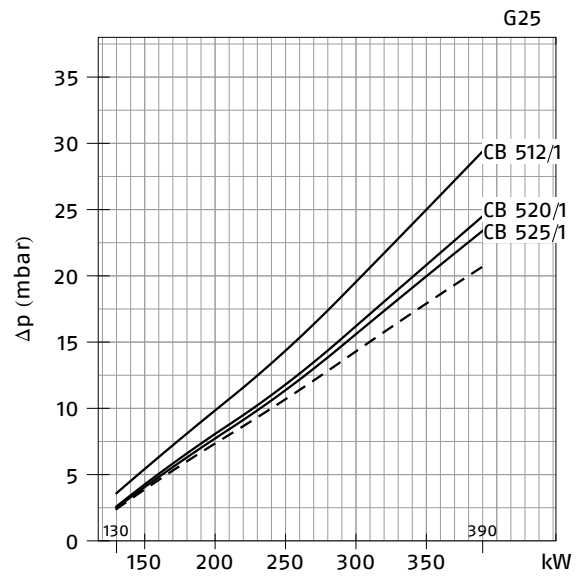
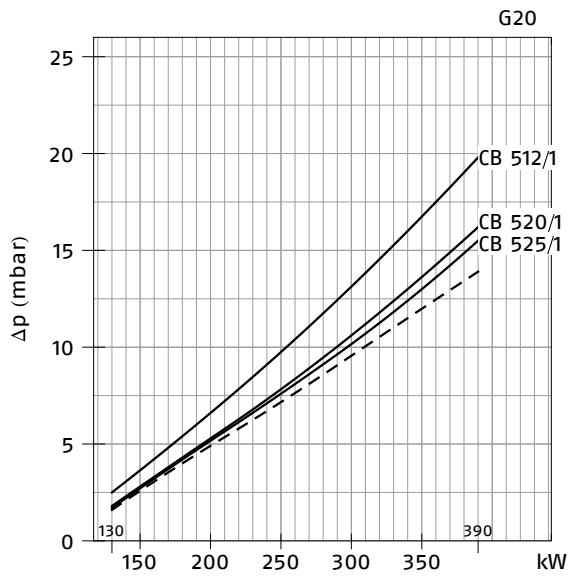

RS 34/M (NATURAL GAS)

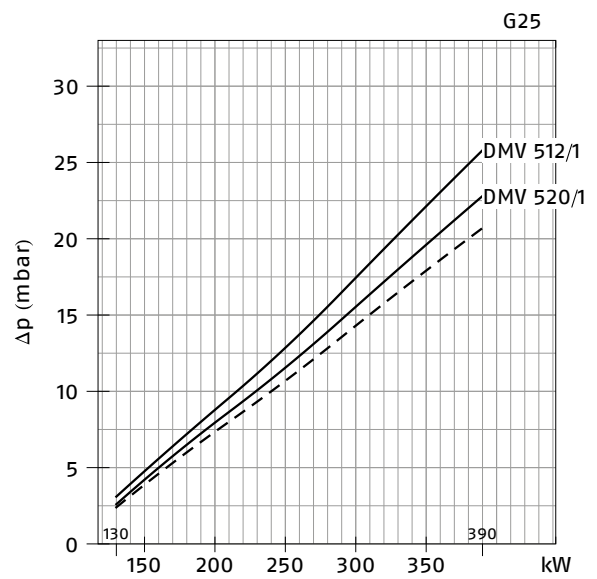
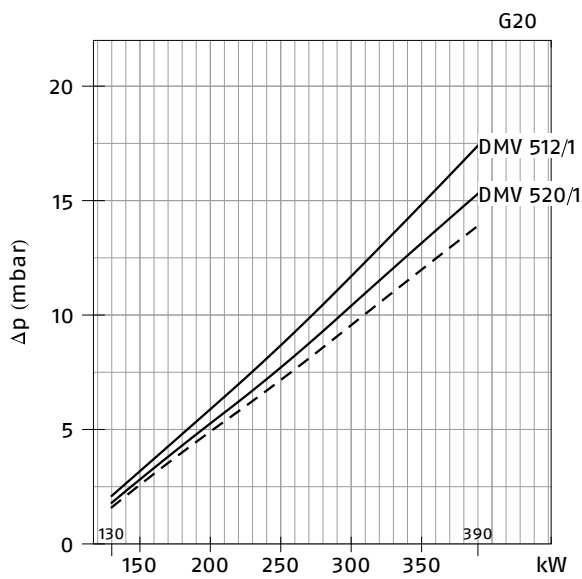

— Combustion head + gas butterfly valve + gas train
 - - - Combustion head + gas butterfly valve

RS 44/M (NATURAL GAS)

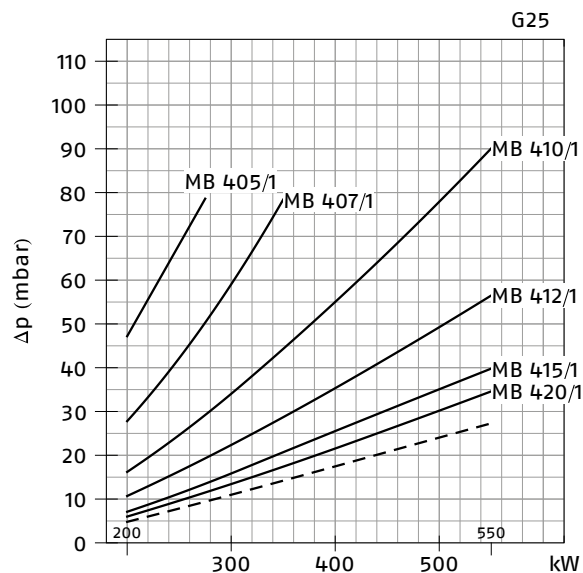
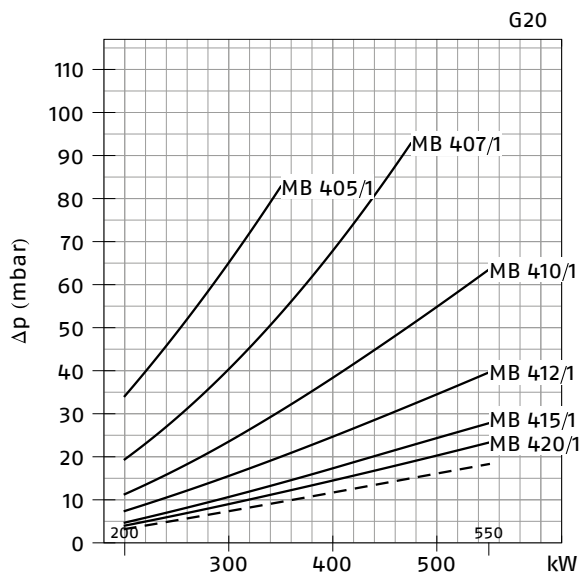

RS 44/M (NATURAL GAS)

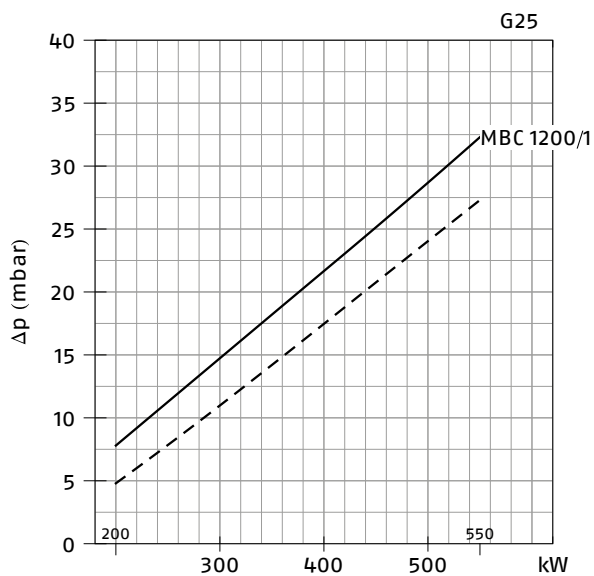
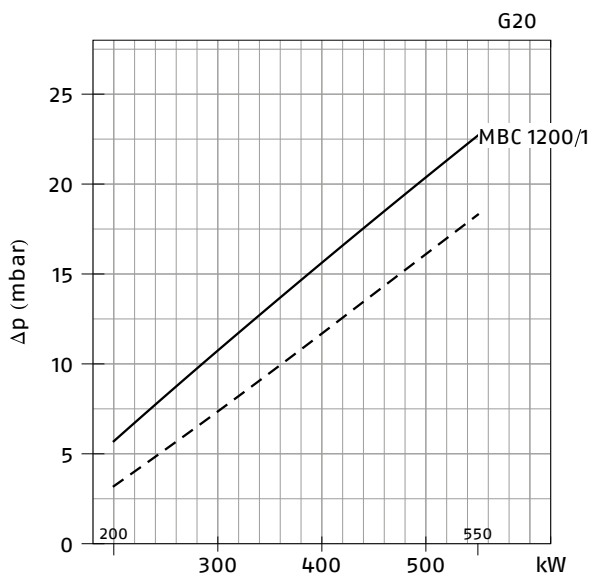

- Combustion head + gas butterfly valve + gas train
- - - Combustion head + gas butterfly valve

RS 44/M (NATURAL GAS)

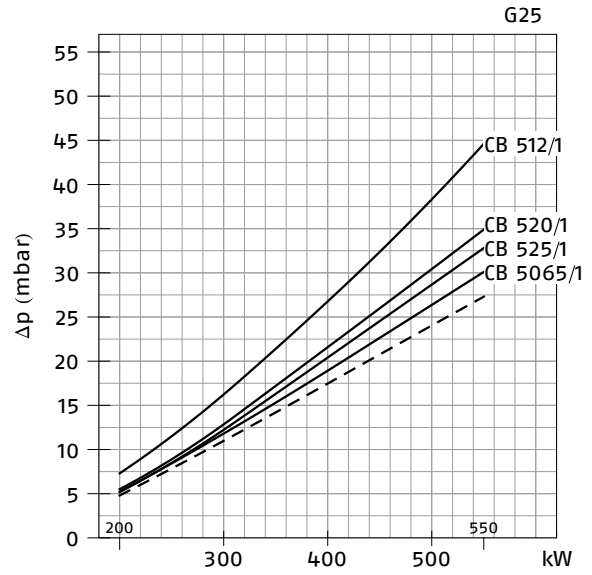
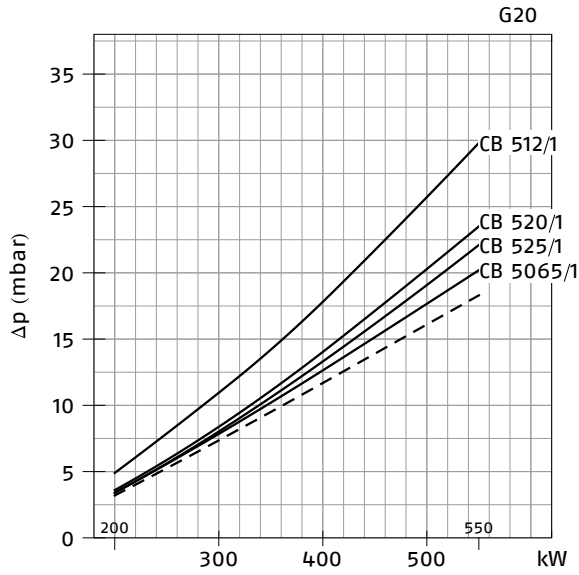

RS 44/M (NATURAL GAS)

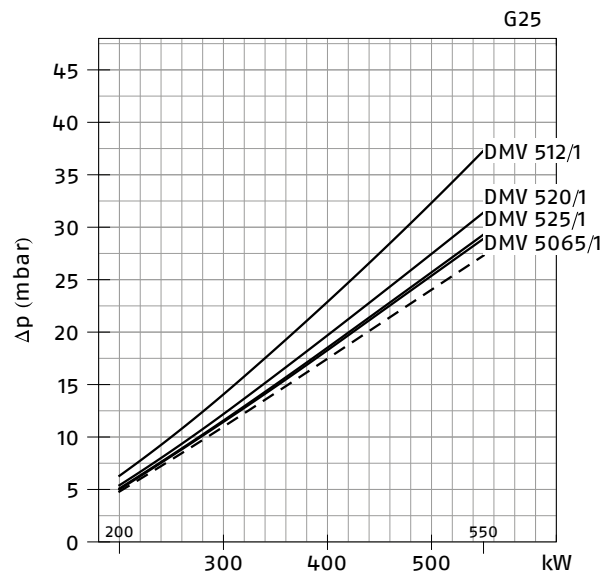
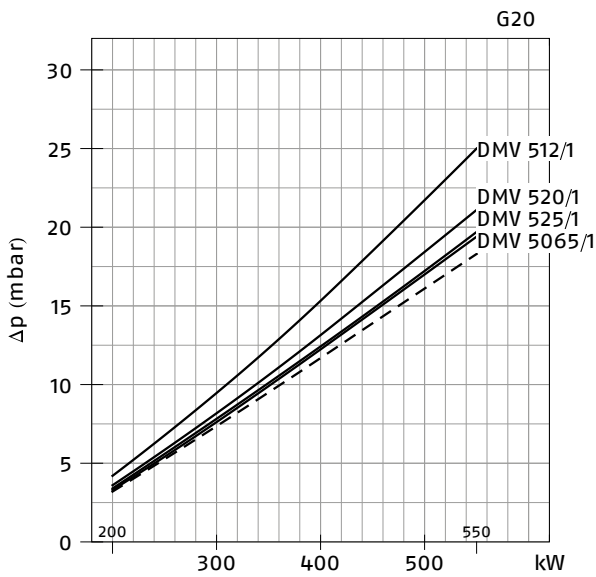

— Combustion head + gas butterfly valve + gas train
 - - - Combustion head + gas butterfly valve

RS 50/M (NATURAL GAS)

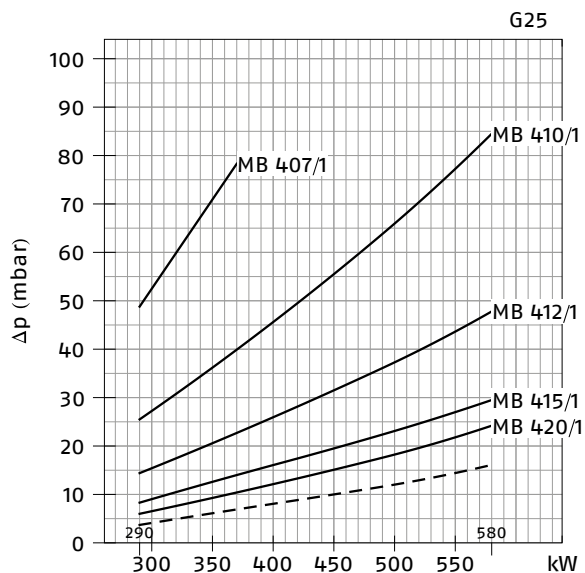
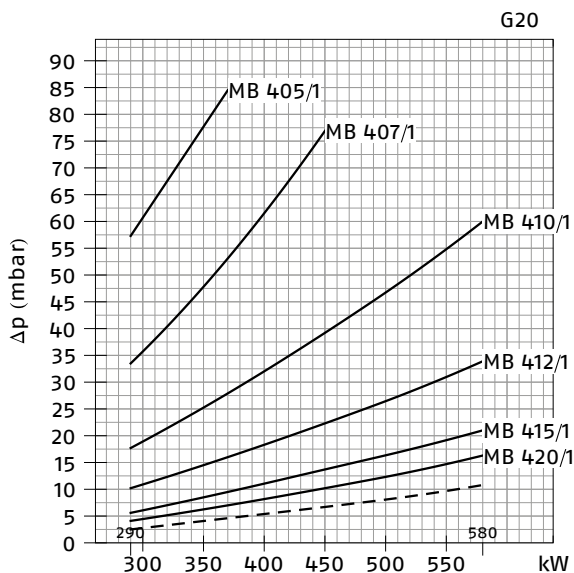

RS 50/M (NATURAL GAS)

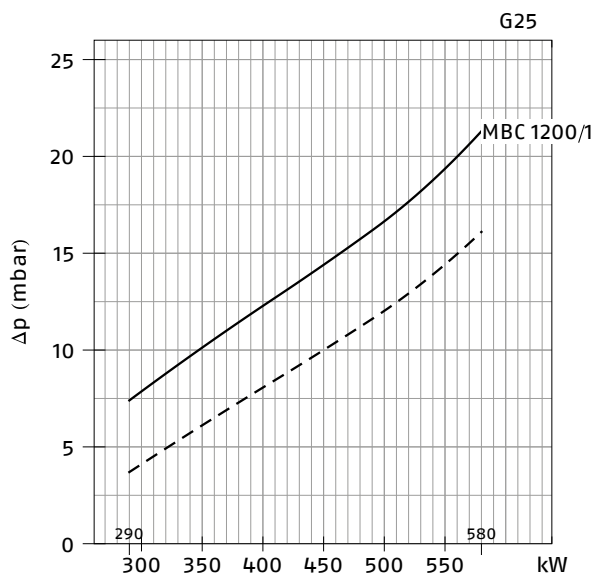
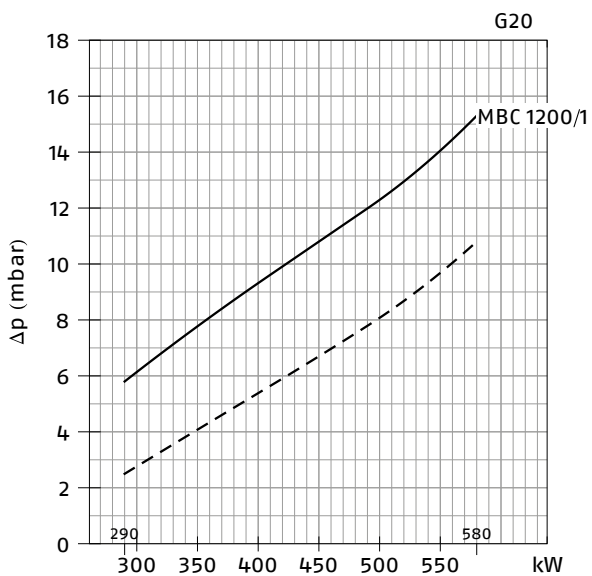

- Combustion head + gas butterfly valve + gas train
- - - Combustion head + gas butterfly valve

RS 50M (NATURAL GAS)

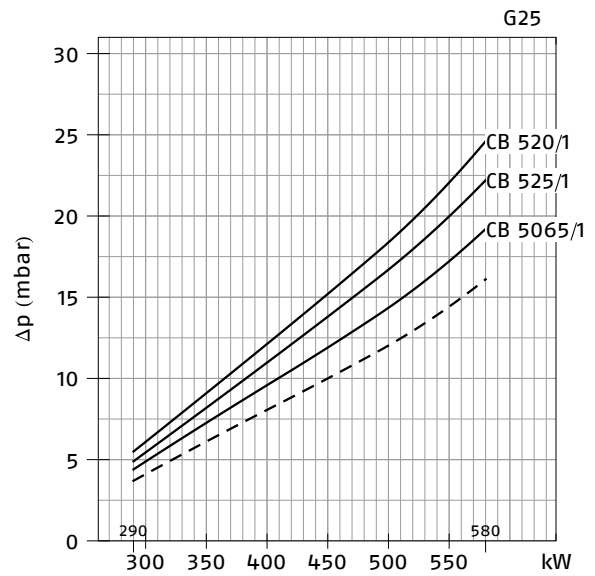
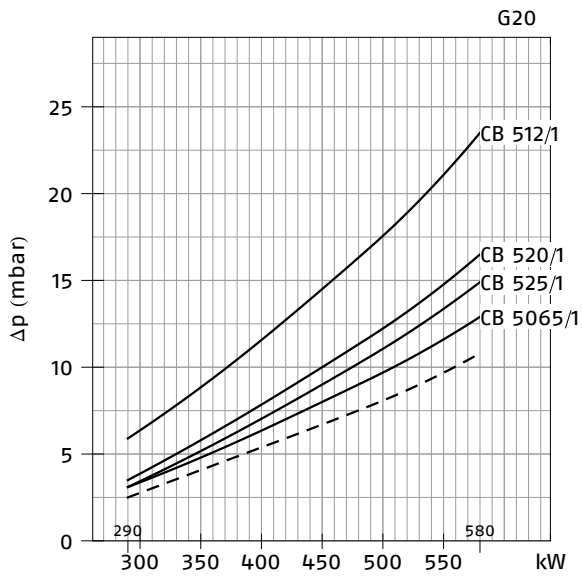

RS 50/M (NATURAL GAS)

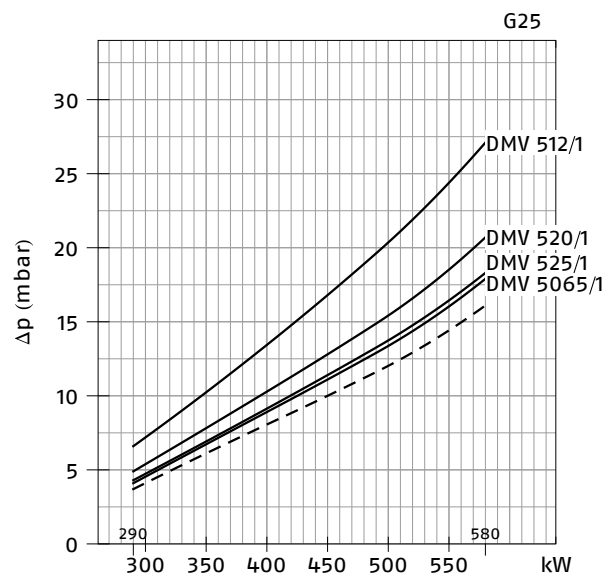
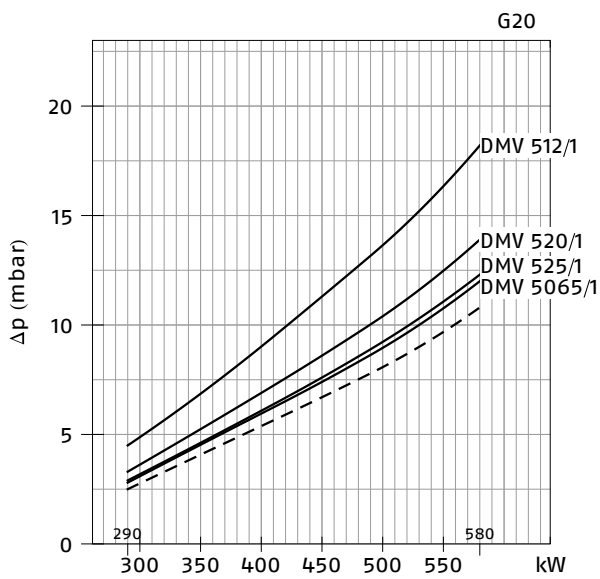

- Combustion head + gas butterfly valve + gas train
- - - Combustion head + gas butterfly valve

RS 64/M (NATURAL GAS)

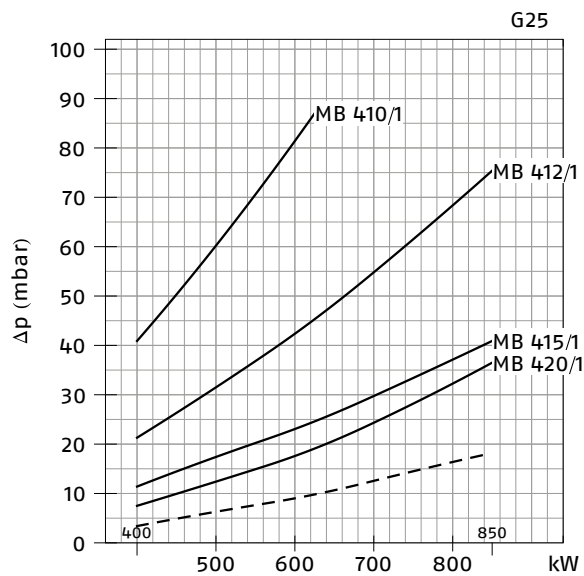
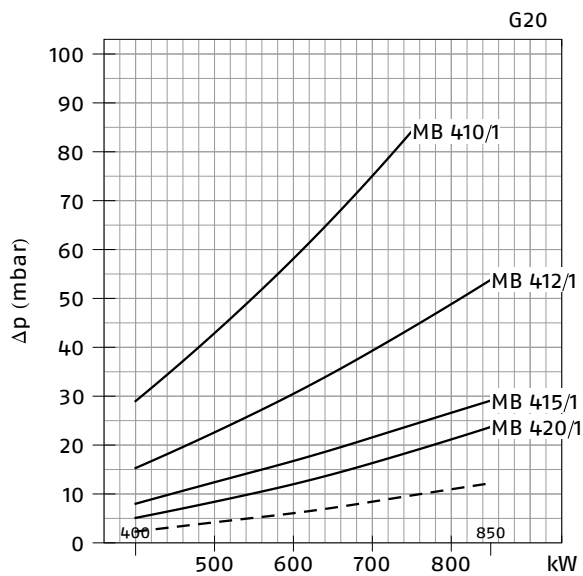

RS 64/M (NATURAL GAS)

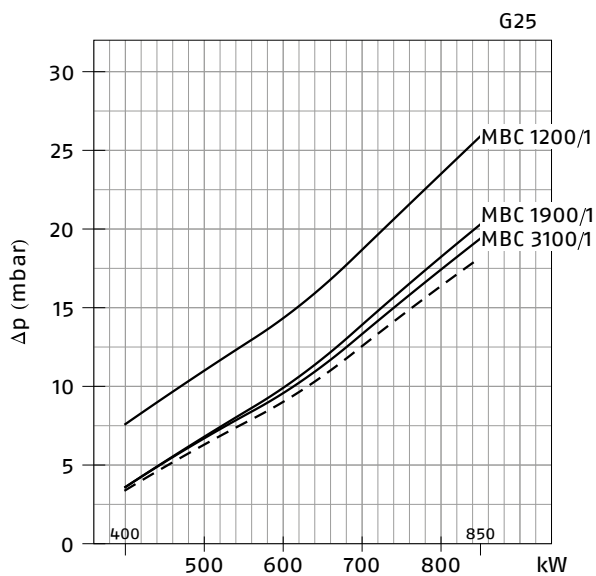
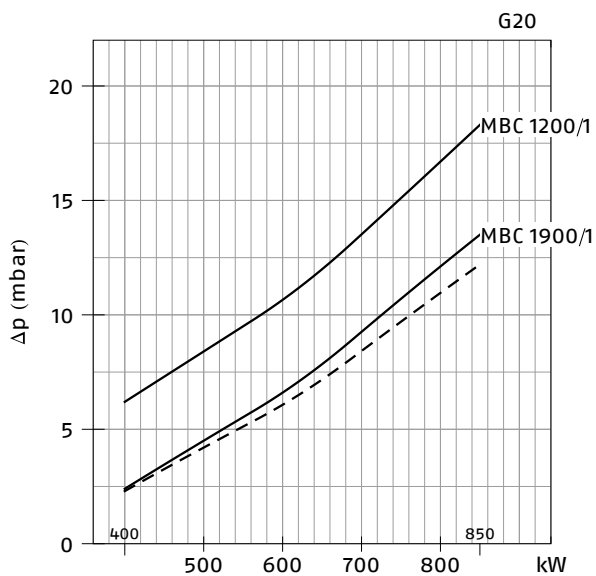

- Combustion head + gas butterfly valve + gas train
- - - Combustion head + gas butterfly valve

RS 64/M (NATURAL GAS)

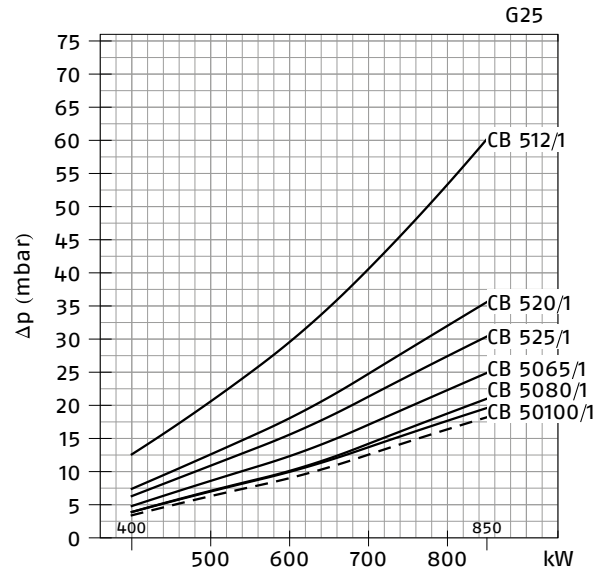
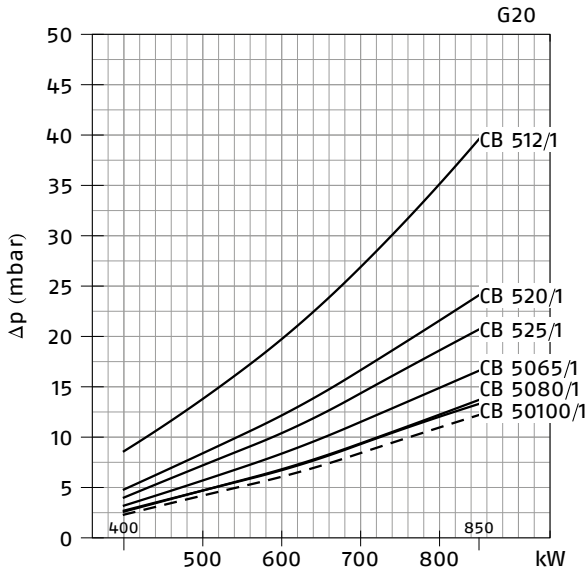

RS 64/M (NATURAL GAS)

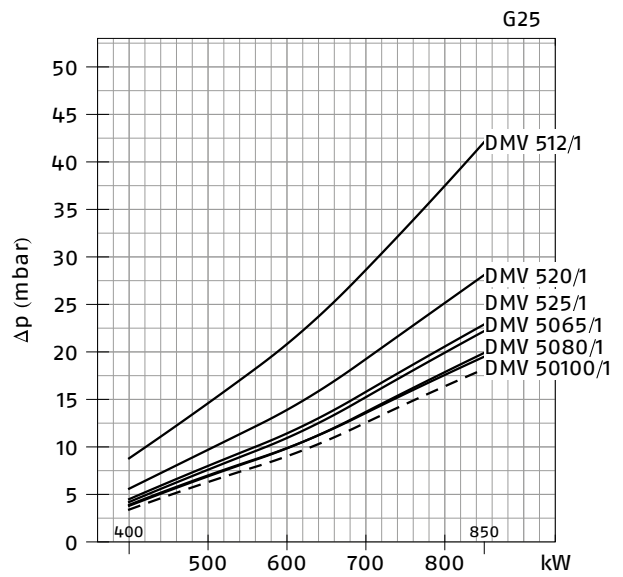
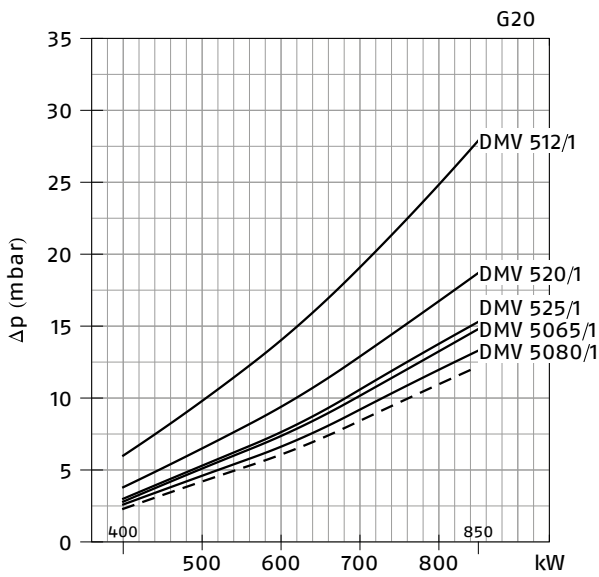

— Combustion head + gas butterfly valve + gas train
 - - - Combustion head + gas butterfly valve

RS 70/M (NATURAL GAS)

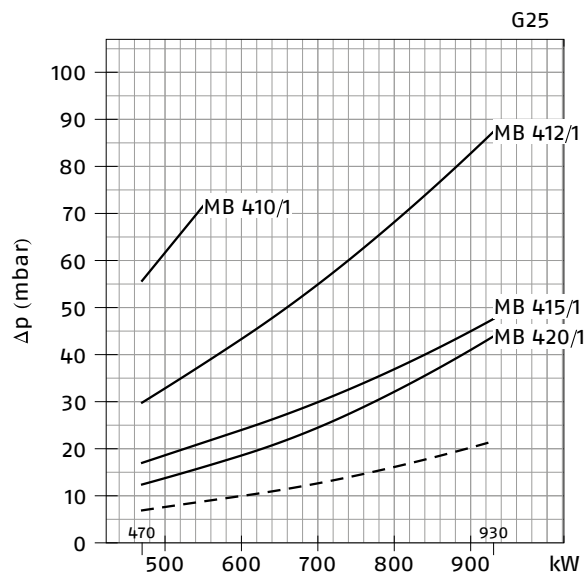
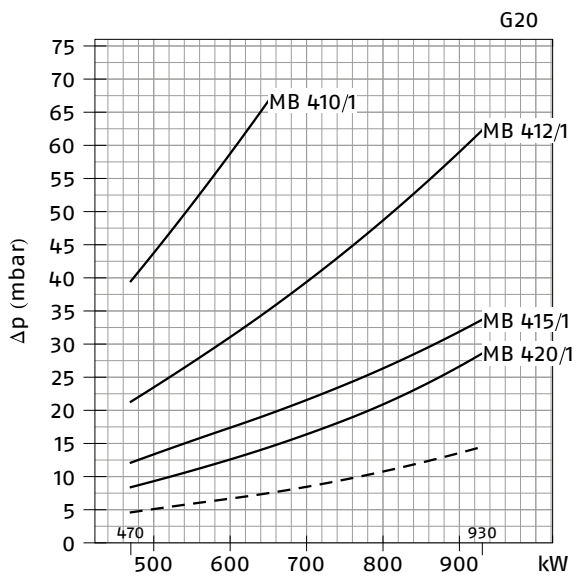

RS 70/M (NATURAL GAS)

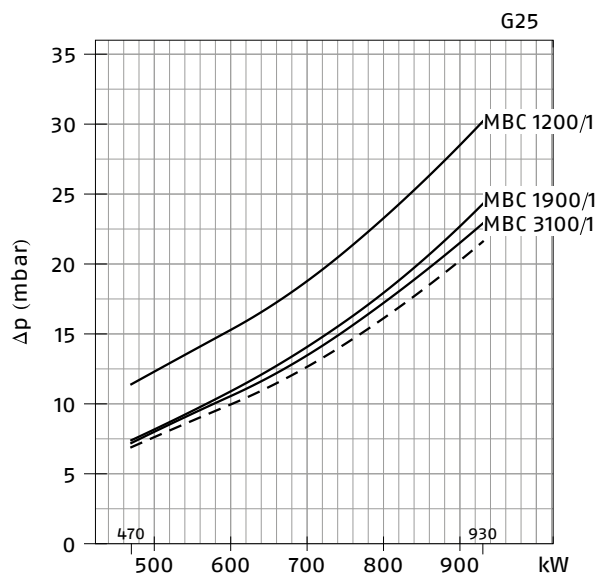
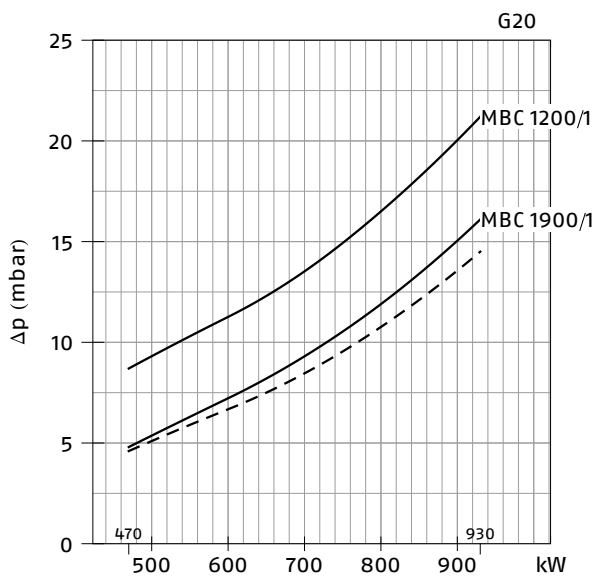

— Combustion head + gas butterfly valve + gas train
 - - - Combustion head + gas butterfly valve

RS 70/M (NATURAL GAS)

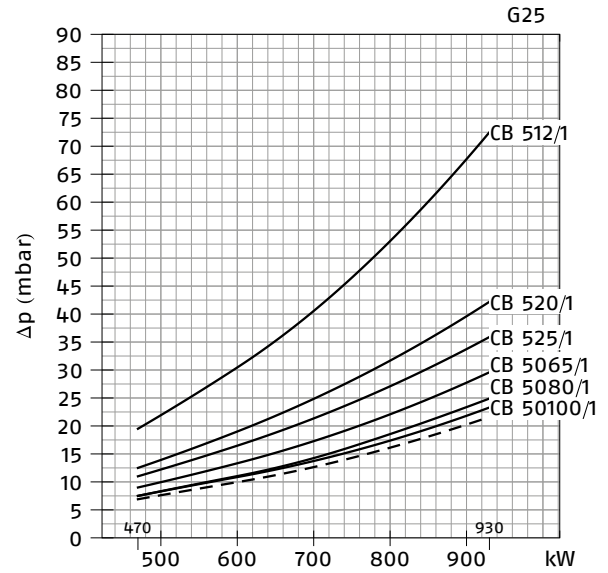
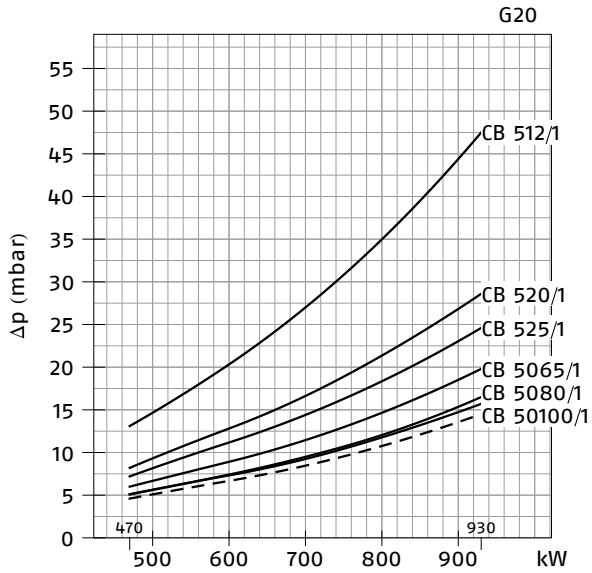

RS 70/M (NATURAL GAS)

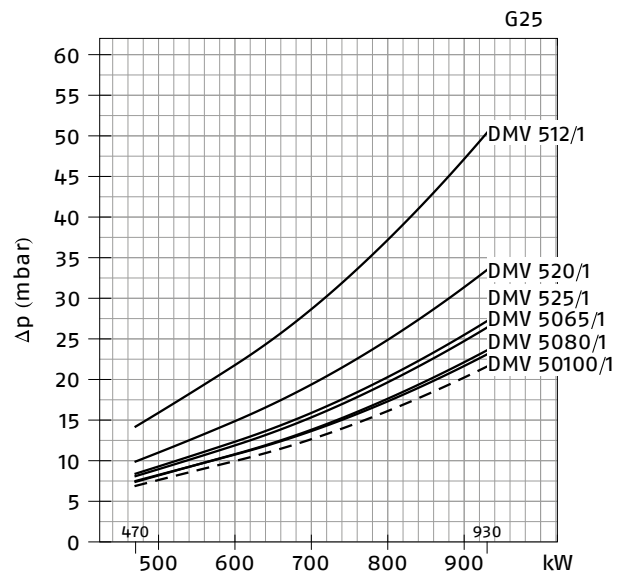
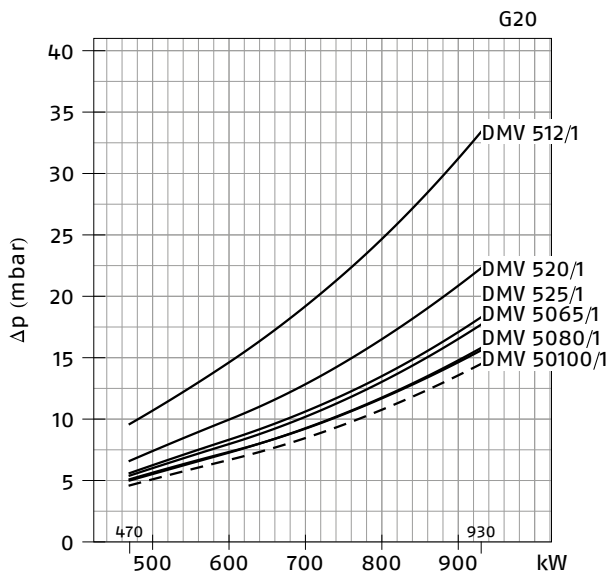

- Combustion head + gas butterfly valve + gas train
- - - Combustion head + gas butterfly valve

RS 100/M (NATURAL GAS)

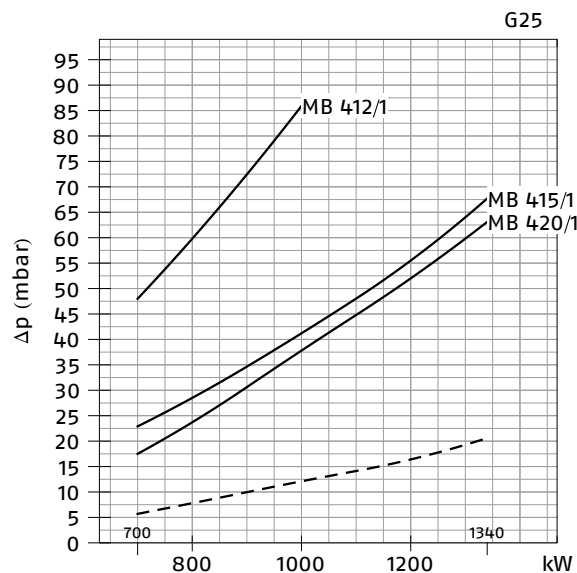
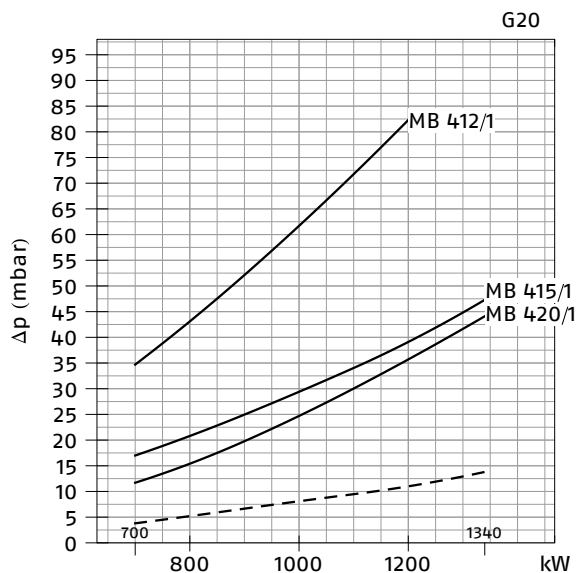

RS 100/M (NATURAL GAS)

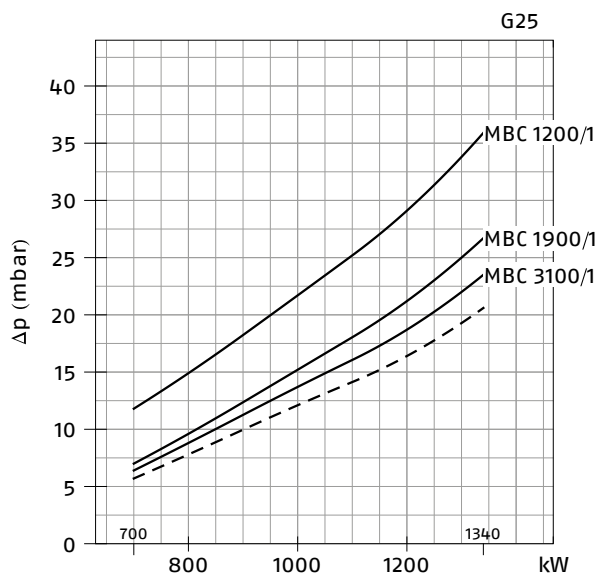
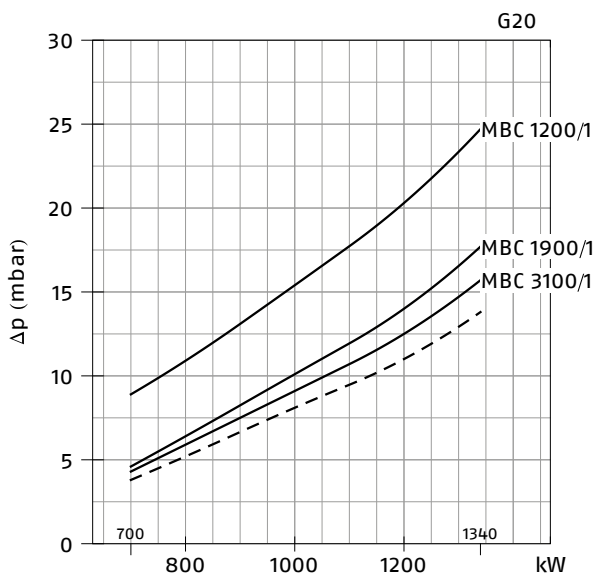

- Combustion head + gas butterfly valve + gas train
- - - Combustion head + gas butterfly valve

RS 100/M (NATURAL GAS)

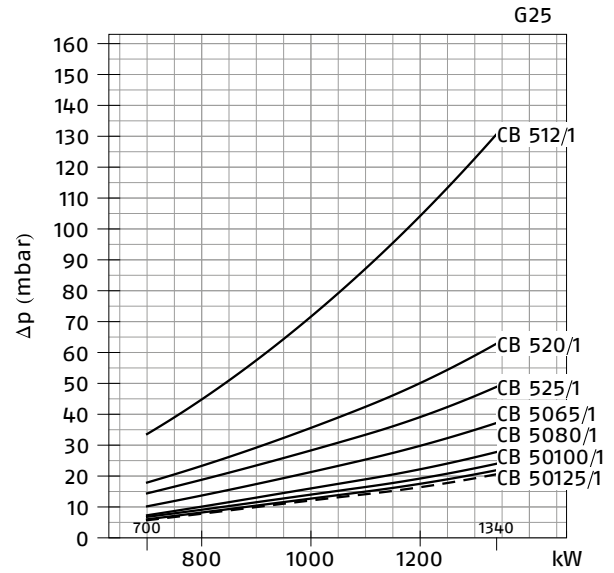
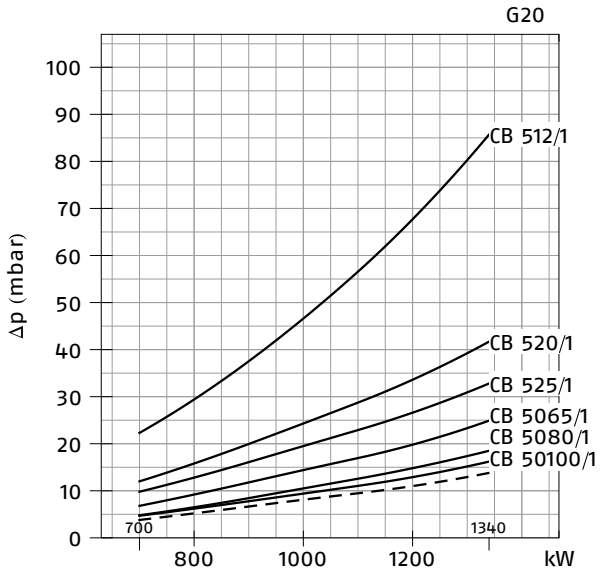

RS 100/M (NATURAL GAS)

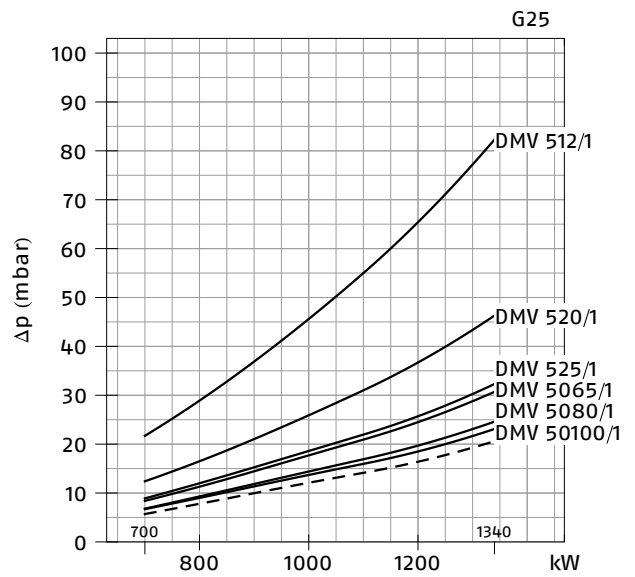
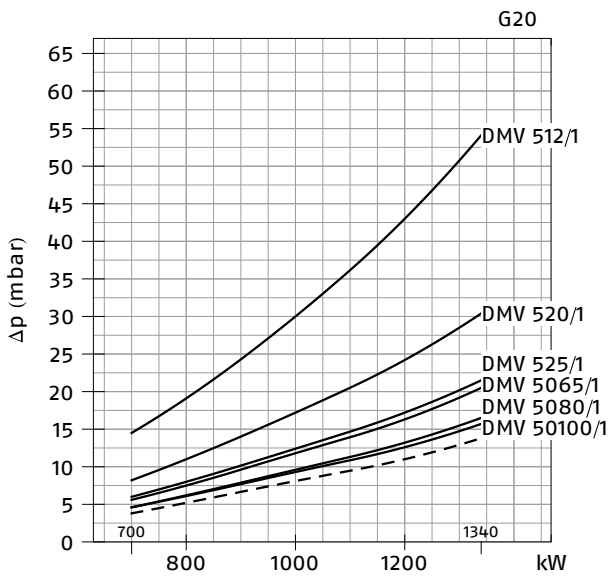

— Combustion head + gas butterfly valve + gas train
 - - - Combustion head + gas butterfly valve

RS 130/M (NATURAL GAS)

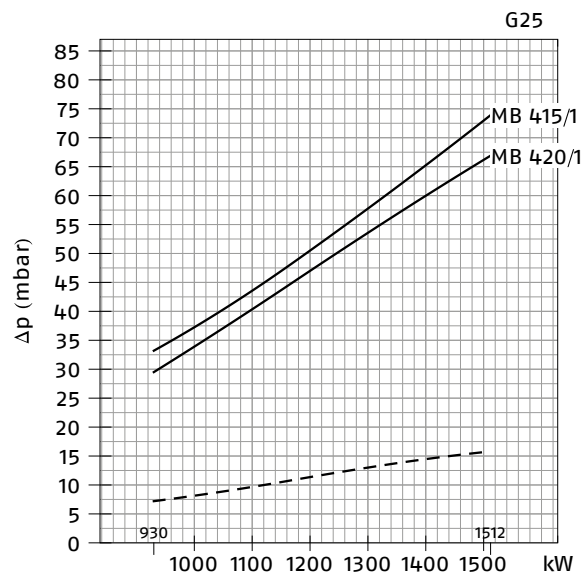
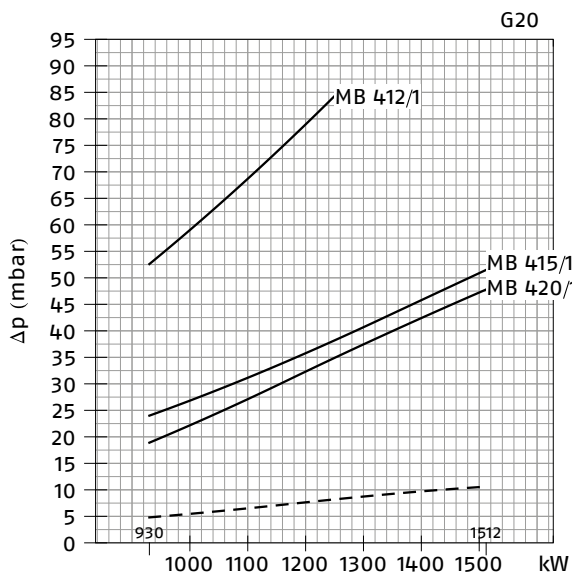

RS 130/M (NATURAL GAS)

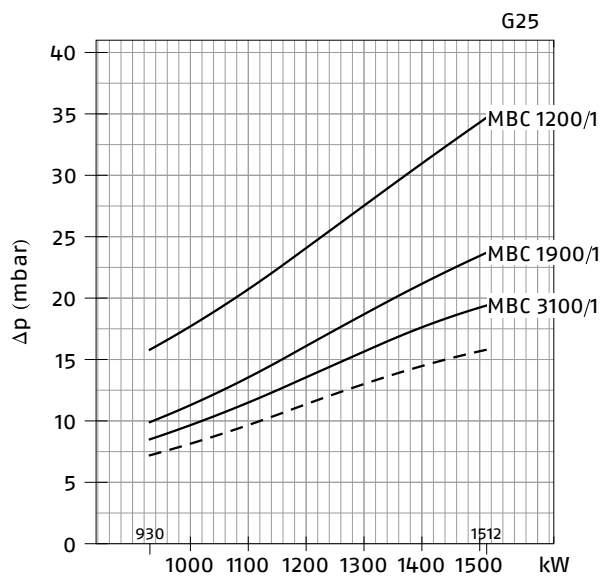
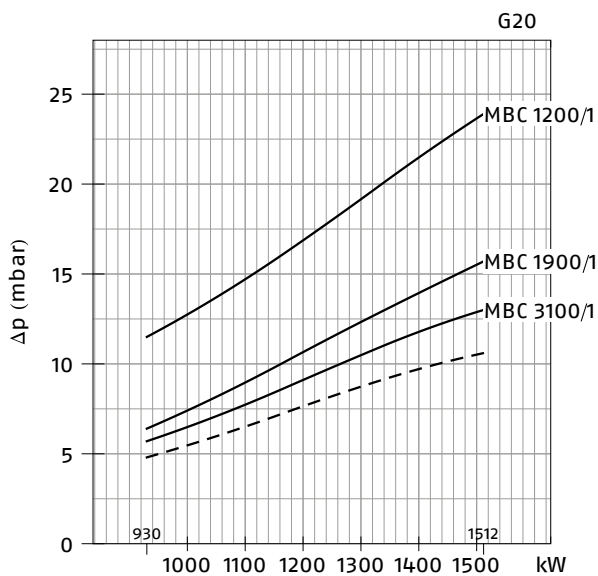

- Combustion head + gas butterfly valve + gas train
- - - Combustion head + gas butterfly valve

RS 130/M (NATURAL GAS)

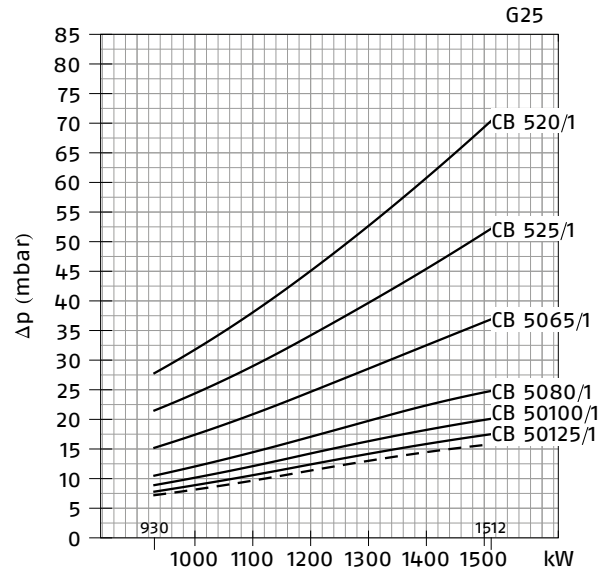
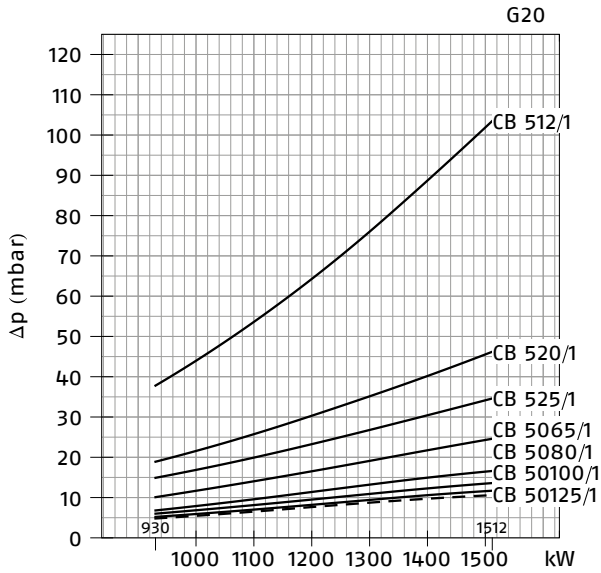

RS 130/M (NATURAL GAS)

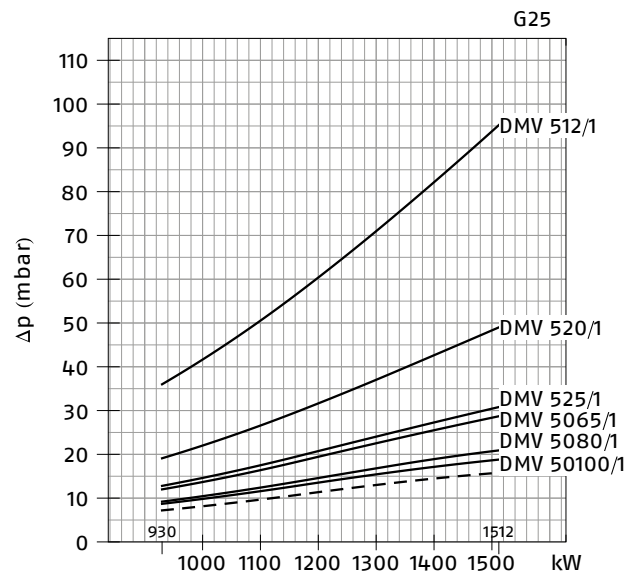
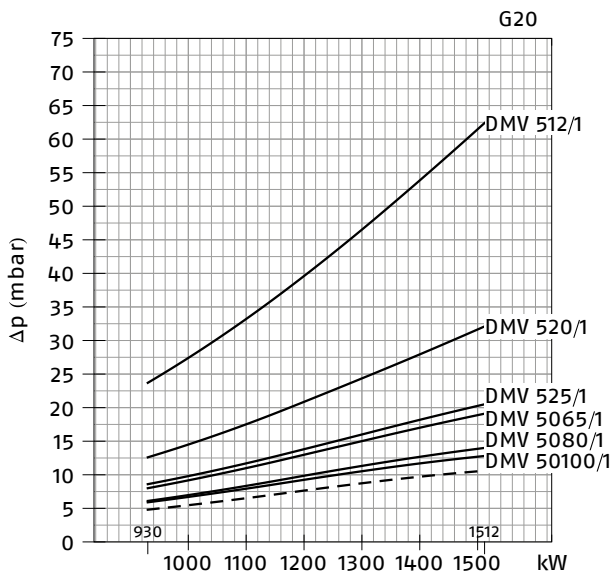

— Combustion head + gas butterfly valve + gas train
 - - - Combustion head + gas butterfly valve

RS 150/M (NATURAL GAS)

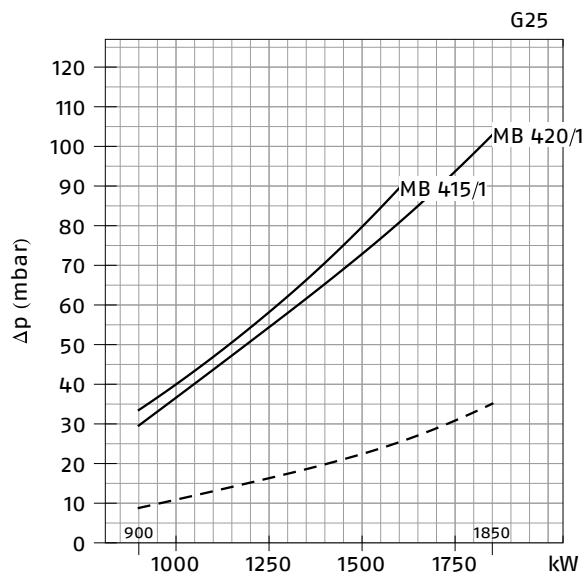
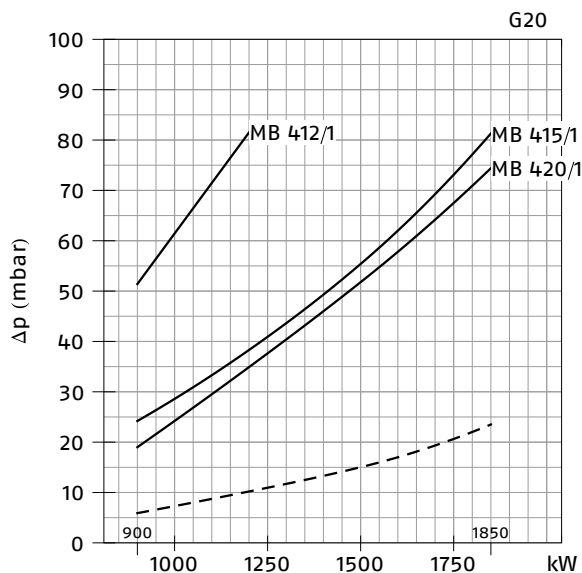

RS 150/M (NATURAL GAS)

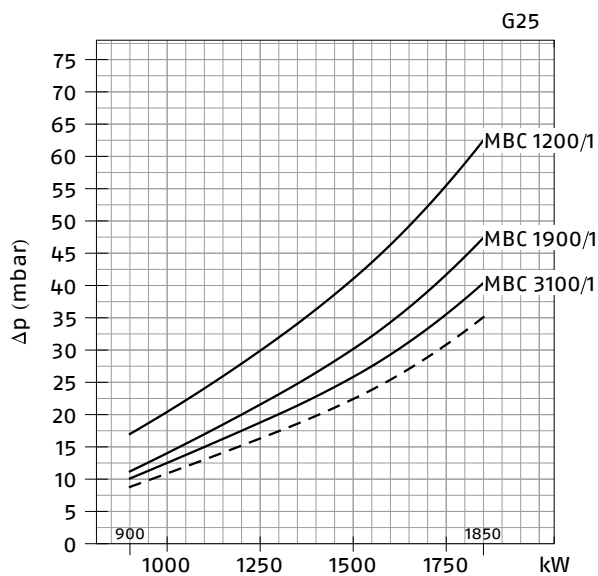
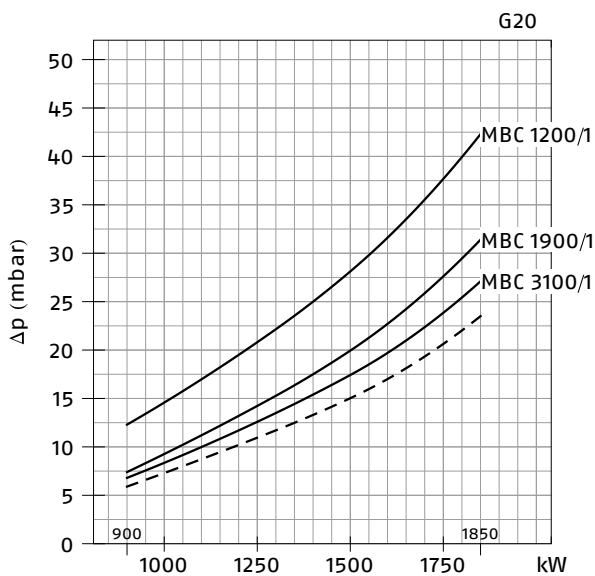

- Combustion head + gas butterfly valve + gas train
- - - Combustion head + gas butterfly valve

RS 150/M (NATURAL GAS)

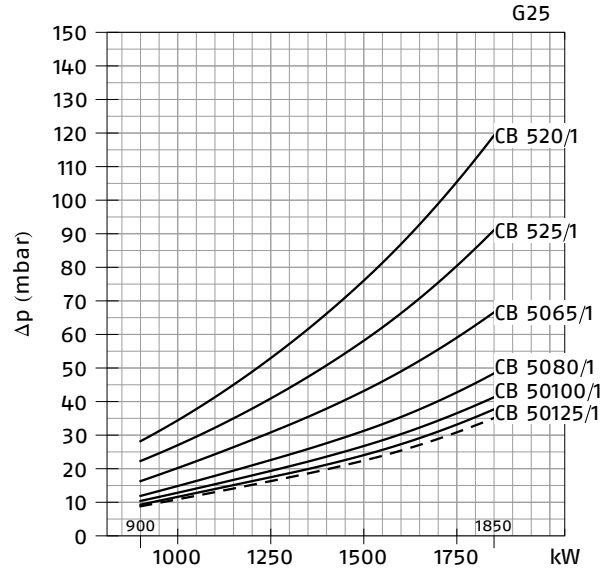
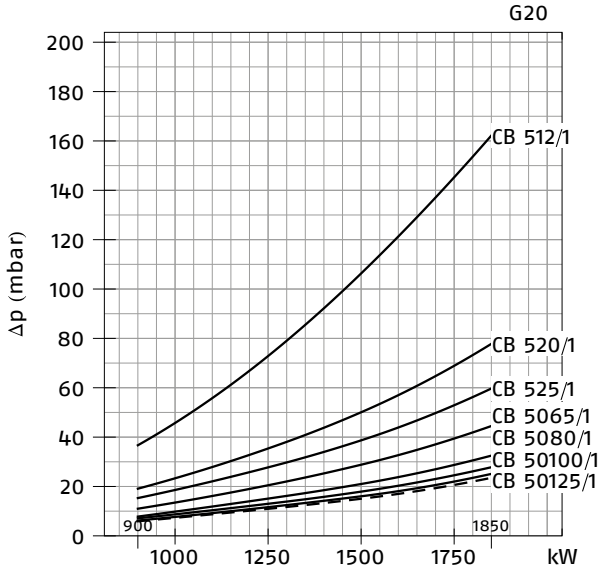

RS 150/M (NATURAL GAS)

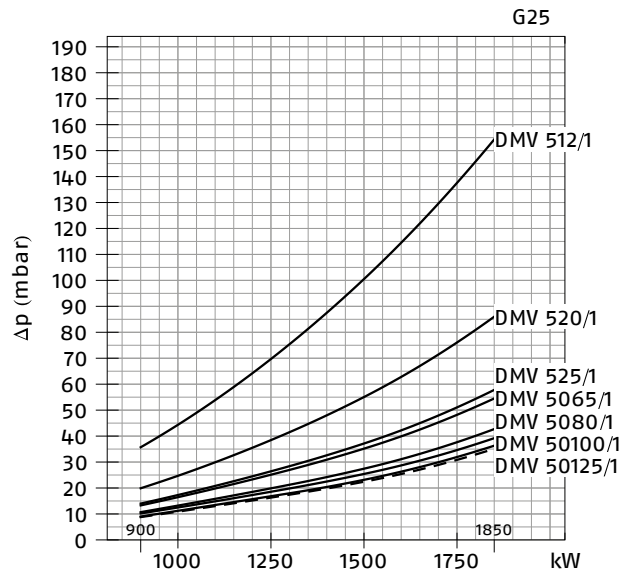
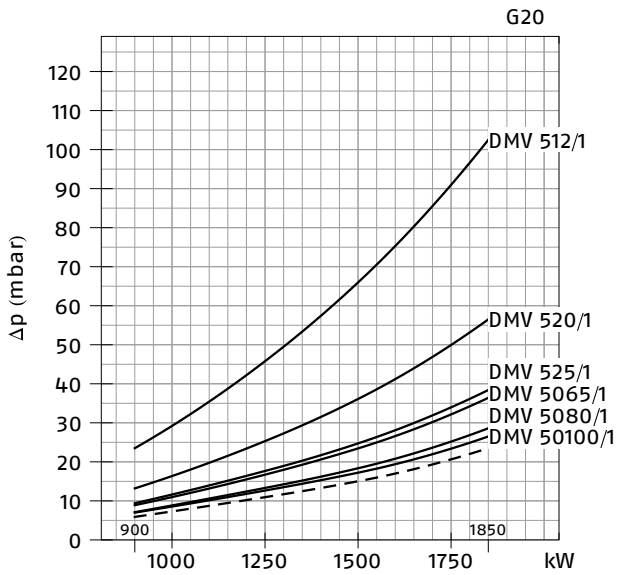

- Combustion head + gas butterfly valve + gas train
- - - Combustion head + gas butterfly valve

RS 190/M (NATURAL GAS)

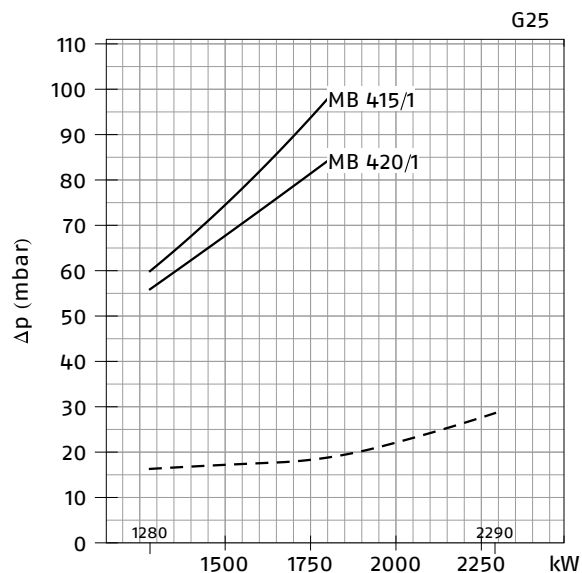
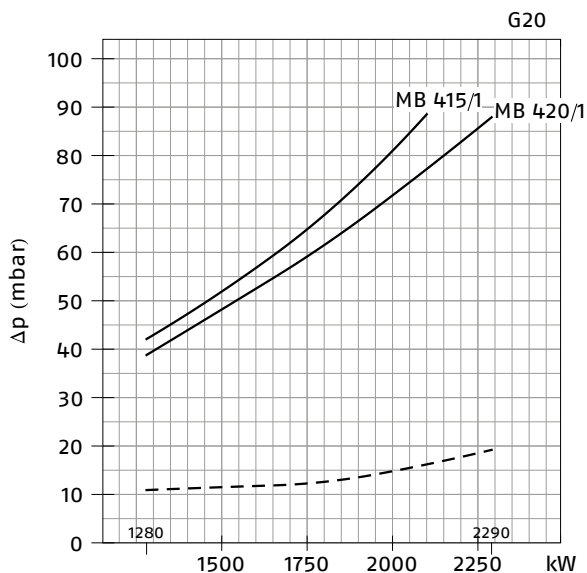

RS 190/M (NATURAL GAS)

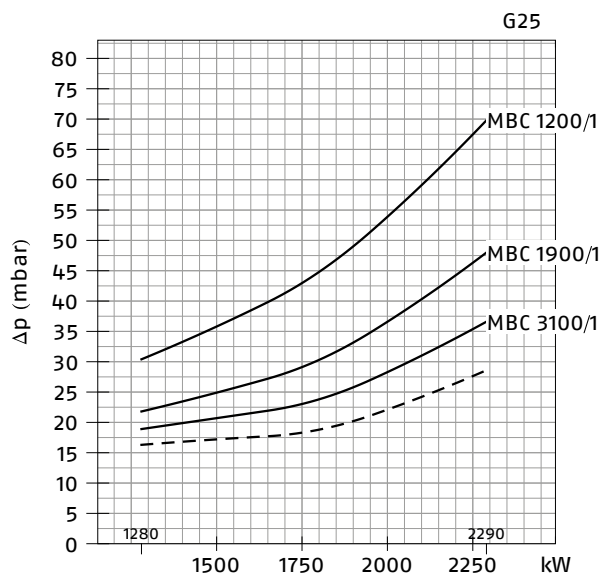
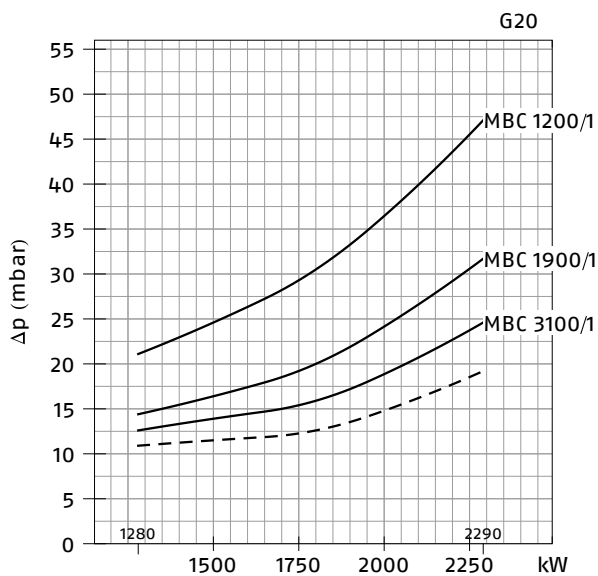

— Combustion head + gas butterfly valve + gas train
 - - - Combustion head + gas butterfly valve

RS 190/M (NATURAL GAS)

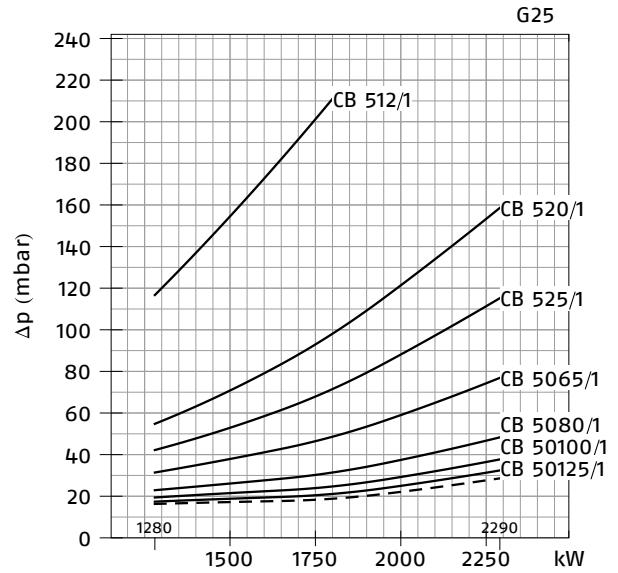
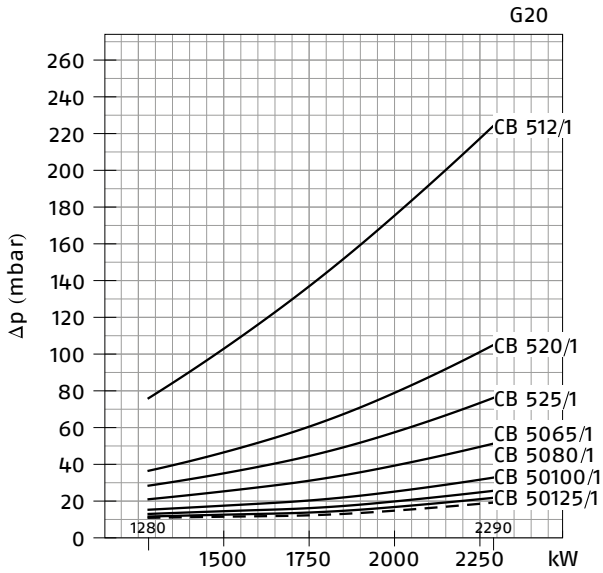

RS 190/M (NATURAL GAS)

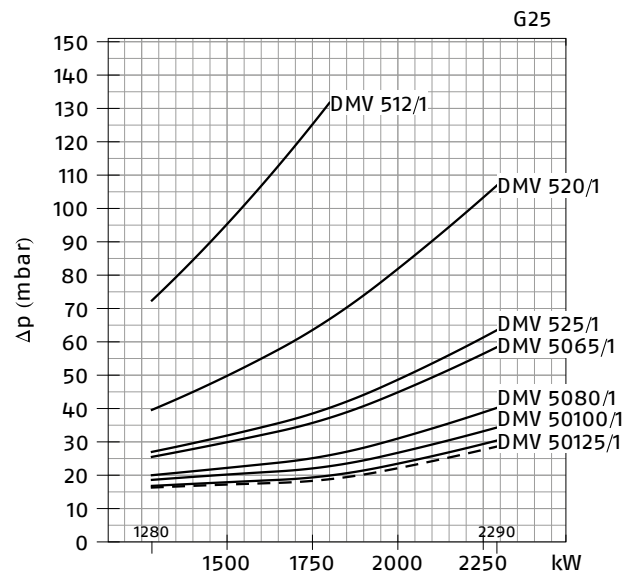
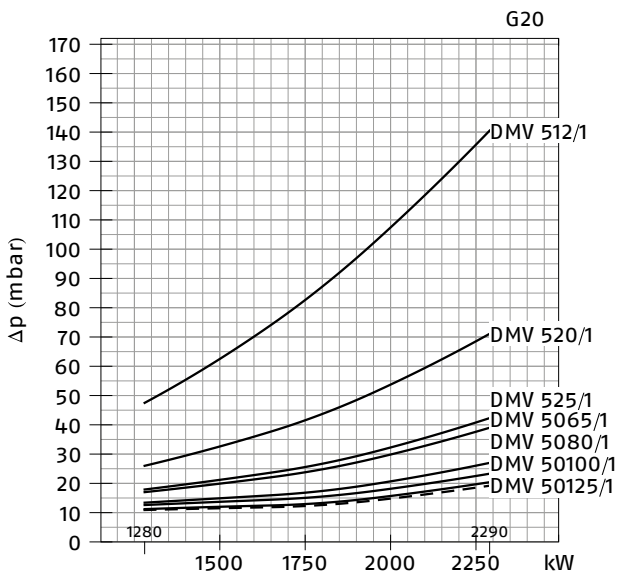

- Combustion head + gas butterfly valve + gas train
- - - Combustion head + gas butterfly valve

RS 250/M (NATURAL GAS)

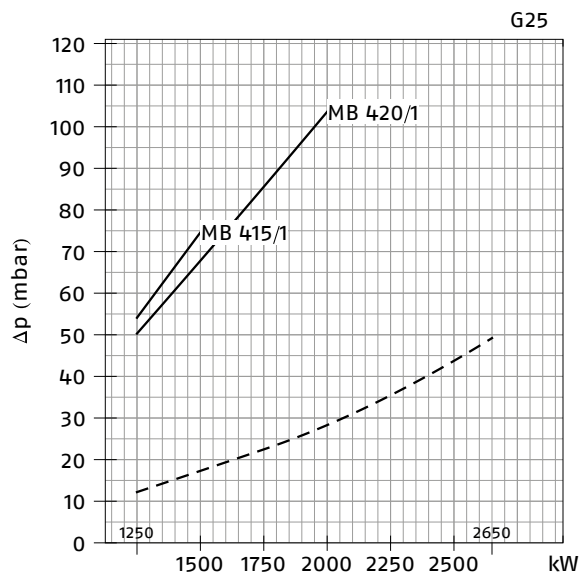
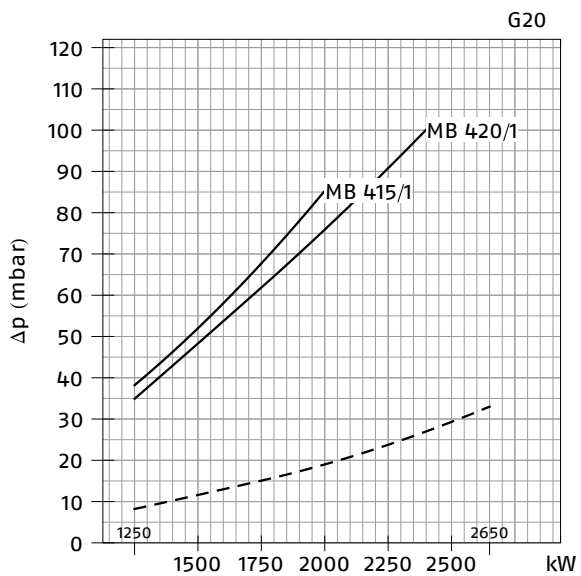

RS 250/M (NATURAL GAS)

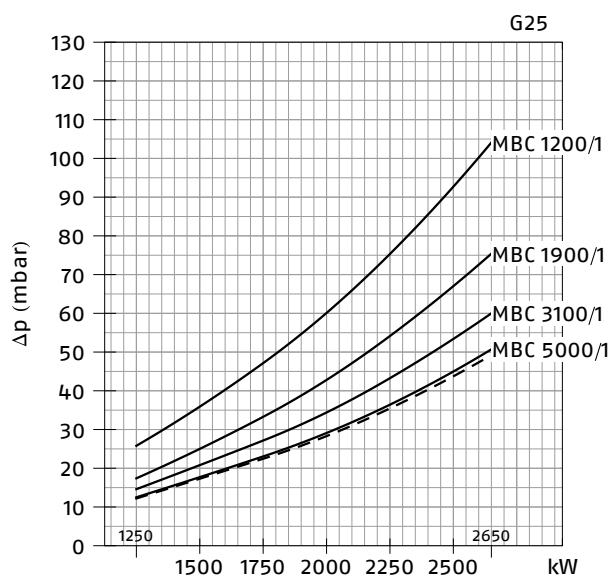
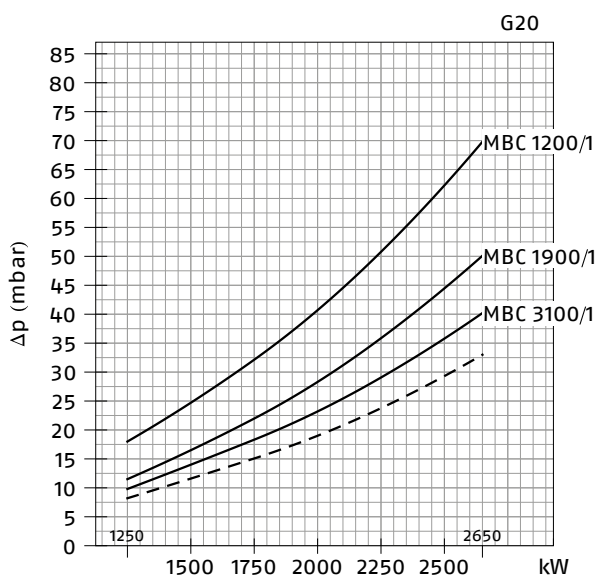

- Combustion head + gas butterfly valve + gas train
- - - Combustion head + gas butterfly valve

RS 250/M (NATURAL GAS)

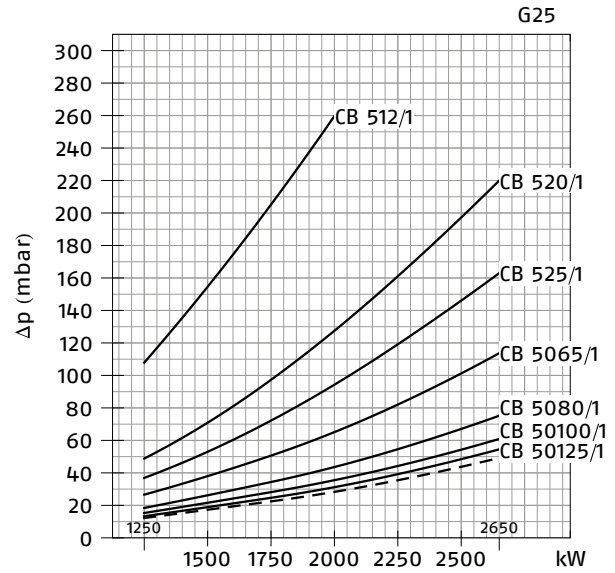
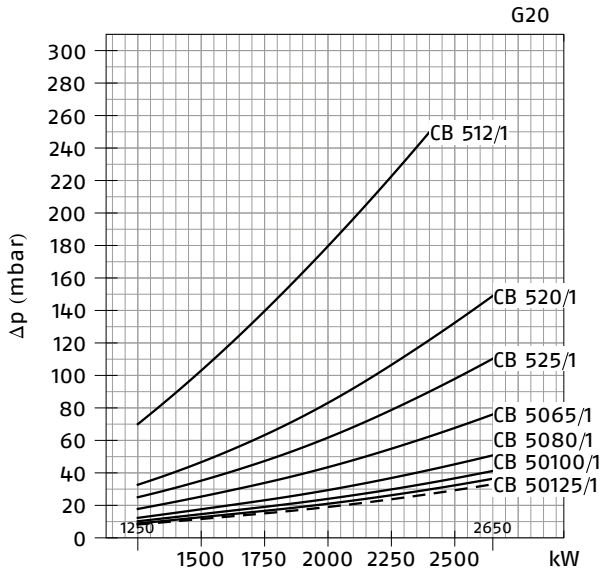

RS 250/M (NATURAL GAS)

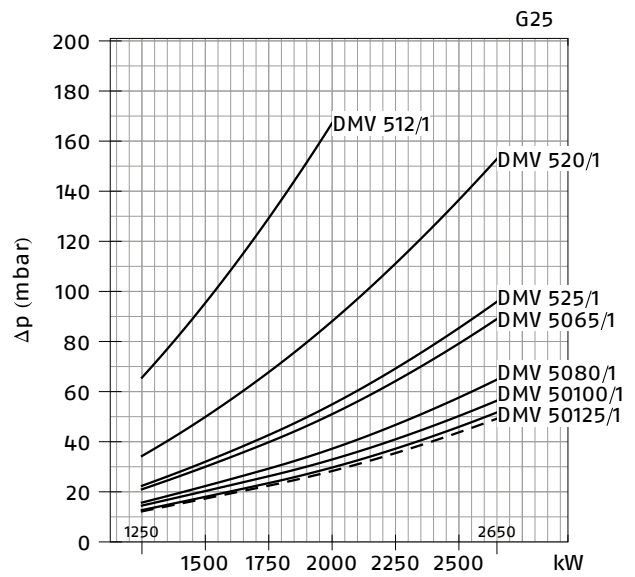
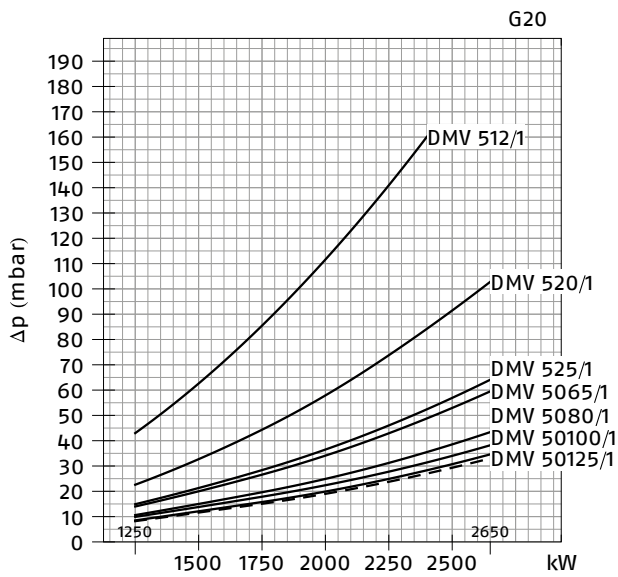

- Combustion head + gas butterfly valve + gas train
- - - Combustion head + gas butterfly valve

| GAS TRAIN | | ADAPTER CODE | | | | | | | | |
|-----------|----------------------|--------------|----------|----------------------|-------|--------|-------------------|--------|--------|----------------------|
| CODE | MODEL | RS 34 | RS 44-50 | RS 64 | RS 70 | RS 100 | RS 130 | RS 150 | RS 190 | RS 250 |
| 3970500 | MB 405/1 - RT 20 | 3000824 | | ● | ● | ● | ● | ● | ● | ● |
| 3970553 | MB 407/1 - RT 20 | | | ● | ● | ● | ● | ● | ● | ● |
| 3970599 | MB 407/1 - RT 52 | | | ● | ● | ● | ● | ● | ● | ● |
| 3970229 | MB 407/1 - RSM 20 | | | ● | ● | ● | ● | ● | ● | ● |
| 3970258 | MB 410/1 - RT 52 | 3010124 | | 3000843 | | ● | ● | ● | ● | ● |
| 3970554 | MB 410/1 - RT 20 | 3000824 | | 3000824 + 3000843 | | ● | ● | ● | ● | ● |
| 3970600 | MB 410/1 - RT 52 | | | | | ● | ● | ● | ● | ● |
| 3970230 | MB 410/1 - RSM 20 | | | | | ● | ● | ● | ● | ● |
| 3970256 | MB 412/1 - RT 52 | - | - | 3000843 | | | | | | |
| 3970144 | MB 412/1 - RT 20 | - | - | | | | | | | |
| 3970197 | MB 412/1 CT RT 20 | - | - | | | | | | | |
| 3970231 | MB 412/1 - RSM 20 | - | - | | | | | | | |
| 3970180 | MB 415/1 - RT 30 | - | - | | | | | | | |
| 3970198 | MB 415/1 CT RT 30 | - | - | | | | | | | |
| 3970250 | MB 415/1 - RT 52 | - | - | | | | | | | |
| 3970253 | MB 415/1 CT RT 52 | - | - | | | | | | | |
| 3970232 | MB 415/1 - RSM 30 | - | - | | | | | | | |
| 3970181 | MB 420/1 - RT 30 | 3000822 | | | | | | | | |
| 3970182 | MB 420/1 CT RT 30 | | | - | - | - | - | - | - | - |
| 3970257 | MB 420/1 - RT 52 | | | - | - | - | - | - | - | - |
| 3970252 | MB 420/1 CT RT 52 | | | - | - | - | - | - | - | - |
| 3970233 | MB 420/1 - RSM 30 | | | - | - | - | - | - | - | - |
| 3970234 | MB 420/1 CT RSM 30 | | | - | - | - | - | - | - | - |
| 3970221 | MBC 1200/1 - RSM 60 | | | - | - | - | - | - | - | - |
| 3970225 | MBC 1200/1 CT RSM 60 | | | - | - | - | - | - | - | - |
| 3970222 | MBC 1900/1 - FSM 40 | ● | ● | 3000825 | | | | | | |
| 3970226 | MBC 1900/1 CT FSM 40 | ● | ● | 3000825 | | | | | | |
| 3970223 | MBC 3100/1 - FSM 40 | ● | ● | 3000826 | | | | | | |
| 3970227 | MBC 3100/1 CT FSM 40 | ● | ● | 3000826 | | | | | | |
| 3970224 | MBC 5000/1 - FSM 80 | ● | ● | ● | ● | ● | ● | ● | ● | 3010370 + 3000826 |
| 3970228 | MBC 5000/1 CT FSM 80 | ● | ● | ● | ● | ● | ● | ● | ● | |
| 3970145 | CB 512/1 - RSM 30 | - | - | 3000843 | | | | | | |
| 20045589 | CB 512/1 CT RSM 30 | - | - | 3000843 | | | | | | |
| 3970146 | CB 520/1 - RSM 30 | 3000822 | | - | - | - | - | - | - | - |
| 3970160 | CB 520/1 CT RSM 30 | | | - | - | - | - | - | - | - |
| 20044659 | CB 525/1 - RSM 30 | | | - | - | - | - | - | - | - |
| 20044660 | CB 525/1 CT RSM 30 | | | - | - | - | - | - | - | - |
| 3970147 | CB 5065/1 - FSM 30 | ● | | 3000825 | | | | | | |
| 3970161 | CB 5065/1 CT FSM 30 | ● | | 3000825 | | | | | | |
| 3970148 | CB 5080/1 - FSM 30 | ● | ● | 3000826 | | | | | | |
| 3970162 | CB 5080/1 CT FSM 30 | ● | ● | 3000826 | | | | | | |
| 3970149 | CB 50100/1 - FSM 30 | ● | ● | 3010370 + 3000826 | | | | | | |
| 3970163 | CB 50100/1 CT FSM 30 | ● | ● | 3010370 + 3000826 | | | | | | |
| 20015871 | CB 50125/1 - FSM 30 | ● | ● | ● | ● | ● | 3010224 + 3000826 | | | |
| 3970196 | CB 50125/1 CT FSM 30 | ● | ● | ● | ● | ● | 3010224 + 3000826 | | | |

Key to layout

● Not available

| GAS TRAIN | | ADAPTER CODE | | | | | | | | |
|-----------|-----------------------|--------------|----------|-------------------|-------|--------|-------------------|--------|--------|--------|
| CODE | MODEL | RS 34 | RS 44-50 | RS 64 | RS 70 | RS 100 | RS 130 | RS 150 | RS 190 | RS 250 |
| 20043035 | DMV 512/1 - RSM -0 | - | - | 3000843 | | | | | | |
| 20043036 | DMV 512/1 CT RSM -0 | - | - | | | | | | | |
| 20043037 | DMV 512/1 CQ RSM -2 | - | - | | | | | | | |
| 20043038 | DMV 520/1 - RSM -0 | 3000822 | | - | - | - | - | - | - | - |
| 20043039 | DMV 520/1 CT RSM -0 | | | - | - | - | - | - | - | - |
| 20043040 | DMV 520/1 CQ RSM -2 | | | - | - | - | - | - | - | - |
| 20043053 | DMV 525/1 - RSM -0 | | | - | - | - | - | - | - | - |
| 20043054 | DMV 525/1 CT RSM -0 | | | - | - | - | - | - | - | - |
| 20043055 | DMV 525/1 CQ RSM -2 | | | - | - | - | - | - | - | - |
| 20043041 | DMV 5065/1 - FSM -0 | ● | 3000825 | | | | | | | |
| 20043042 | DMV 5065/1 CT FSM -0 | ● | | | | | | | | |
| 20043043 | DMV 5065/1 CQ FSM -2 | ● | | | | | | | | |
| 20043044 | DMV 5080/1 - FSM -0 | ● | ● | 3000826 | | | | | | |
| 20043045 | DMV 5080/1 CT FSM -0 | ● | ● | | | | | | | |
| 20043046 | DMV 5080/1 CQ FSM -2 | ● | ● | | | | | | | |
| 20043047 | DMV 50100/1 - FSM -0 | ● | ● | 3010370 + 3000826 | | | | | | |
| 20043048 | DMV 50100/1 CT FSM -0 | ● | ● | | | | | | | |
| 20043049 | DMV 50100/1 CQ FSM -2 | ● | ● | | | | | | | |
| 20043050 | DMV 50125/1 - FSM -0 | ● | ● | ● | ● | ● | 3010224 + 3000826 | | | |
| 20043051 | DMV 50125/1 CT FSM -0 | ● | ● | ● | ● | ● | | | | |
| 20043052 | DMV 50125/1 CQ FSM -2 | ● | ● | ● | ● | ● | | | | |

Key to layout

● Not available

Ventilation

The ventilation circuit produces low noise levels with high performance pressure and air output, in spite of the compact dimensions.

The use of sound-proofing material on all models keeps noise level very low.

A variable profile cam connects the fuel and air regulations, ensuring high fuel efficiency at all firing ranges. A minimum air pressure switch stops the burner when there is an insufficient quantity of air at the combustion head.

The RS 34/M MZ and RS 44/M MZ are realised with a structure made by an innovative technology based on a new fibreglass reinforced polyamide material, with high thermal and mechanical characteristics, instead of the traditional aluminium.

This allows big advantages in terms of lay-out rationalisation, weight and dimensions reduction.

In order to guarantee the correct exercise temperature for the internal burner components in every working conditions, the new structure includes an innovative patented cooling technology.

Between the burner front base and the reinforcing steel front plate, had been create an air cavity offering an high thermal insulation against the front boiler reflection heat, and to further improve the insulation efficiency the innovative HCS (Housing Cooling System) technology had been developed.

Inside the front base cavity an air circulation is activated with continuous air volume refresh to obtain an active cooling system and avoid any heat transfer to the electrical component housing.



Example of the servomotor for gas setting.



Example of HCS (Housing Cooling System) working concept.

Combustion Head

Different lengths of the combustion head can be chosen for the RS/M series of burners. The choice depends on the thickness of the front panel and the type of boiler. Depending on the type of generator, check that the penetration of the head into the combustion chamber is correct. The internal positioning of the combustion head can easily be adjusted to the maximum defined output by adjusting a screw fixed to the flange.



Example of a RS/M burner combustion head.

SUGGESTED COMBUSTION CHAMBER DIMENSIONS

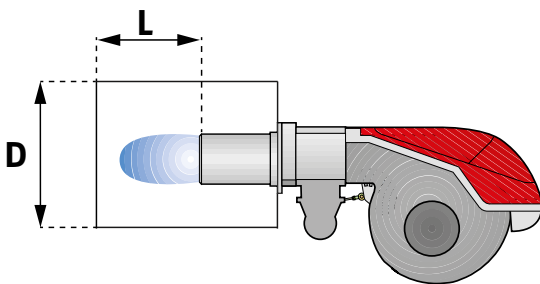

Example:
 Burner thermal output = 2000 kW;
 L Combustion Chamber (m) = 2,7 m (medium value);
 D Combustion Chamber (m) = 0,8 m (medium value)

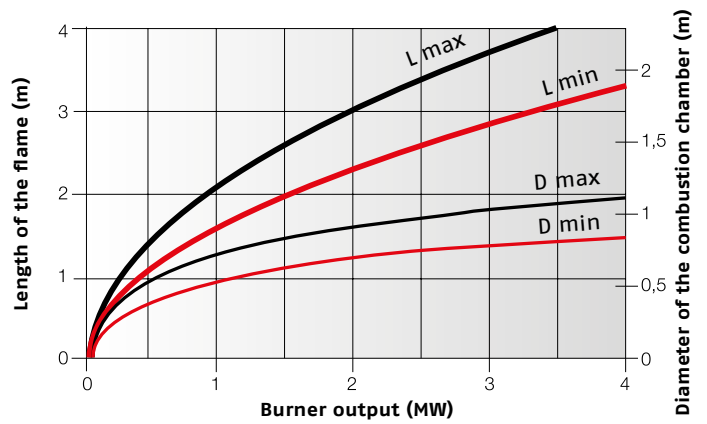

Operation

BURNER OPERATION MODE

The RS/M series of burners can have “two stage progressive” or “modulating” operation.



Output regulator.



Analog control signal converter.

On “two stage progressive” operation, the burner gradually adapts the output to the requested level, by varying between two pre-set levels (see picture A).

In “modulating” operation, normally required in steam generators, in superheated boilers or diathermic oil burners, a specific regulator or an analog control signal converter are required. These are supplied as accessories that must be ordered separately. The burner can work for long periods at intermediate output levels (see picture B).

“TWO STAGE PROGRESSIVE” OPERATION

“MODULATING” OPERATION

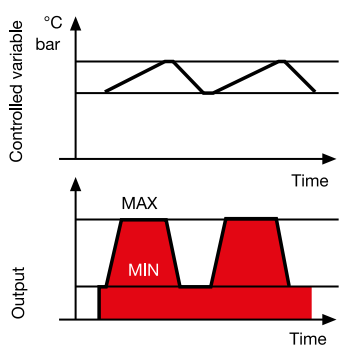

Picture A

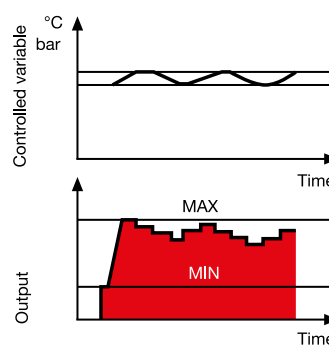

Picture B

The RS 34-44-64-250/M MZ burner models are fitted with a new microprocessor control panel, RMG/M, for the supervision during intermittent operation.

For helping the commissioning and maintenance work, there are two main elements:

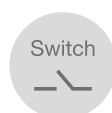

The lock-out reset button is the central **operating element** for resetting the burner control and for activating / deactivating the diagnostic functions.

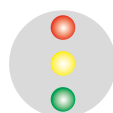

The multi-color LED is the central **indication element** for visual diagnosis and interface diagnosis.

Both elements are located under the transparent cover of lock-out reset button, as showed below.



There are two diagnostic choices, for indication of operation and diagnosis of fault cause:

VISUAL DIAGNOSIS



INTERFACE DIAGNOSIS

By the interface adapter and a PC with dedicated software or by a predisposed flue gas analyzer (see paragraph accessories).

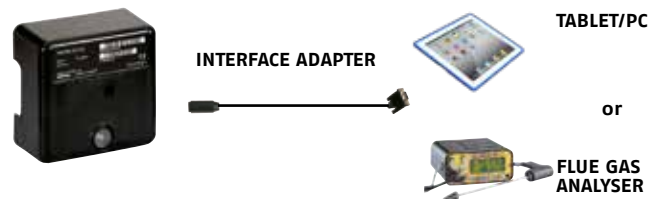

INDICATION OF OPERATION

In normal operation, the various status are indicated in the form of colour codes according to the table below.
The interface diagnosis (with adapter) can be activated by pressing the lock-out button for over 3 seconds.

| COLOR CODE TABLE | | | | | | | |
|-----------------------------|------------------|---|---|---|---|---|---|
| Operation status | Color code table | | | | | | |
| Stand-by | ● | ● | ● | ● | ● | ● | ● |
| Pre-purging | ● | ● | ● | ● | ● | ● | ● |
| Ignition phase | ● | ● | ● | ● | ● | ● | ● |
| Flame OK | ● | ● | ● | ● | ● | ● | ● |
| Poor flame | ● | ● | ● | ● | ● | ● | ● |
| Undervoltage, built-in fuse | ● | ● | ● | ● | ● | ● | ● |
| Fault, alarm | ● | ● | ● | ● | ● | ● | ● |
| Flame simulation | ● | ● | ● | ● | ● | ● | ● |

● LED off

DIAGNOSIS OF FAULT CAUSES

After lock-out has occurred, the red signal lamp is steady on. In this status, the visual fault diagnosis according to the error code table can be activated by pressing the lock-out reset button for over 3 seconds.

The interface diagnosis (with adapter) can be activated by pressing again the lock-out button for over 3 seconds.

The flashing of red LED are a signal with this sequence:
(e.g. signal with n° 3 flashes – faulty air pressure monitor)



ERROR CODE TABLE

| POSSIBLE CAUSE OF FAULT | FLASH CODE |
|----------------------------------------------------------------------------------------------------------------------------------------------------------------------------------------------------|---------------|
| No establishment of flame at the end of safety time: - faulty or soiled fuel valves - faulty or soiled flame detector - poor adjustment of burner, no fuel - faulty ignition equipment | ● 2x flashes |
| Faulty air pressure monitor | ● 3x flashes |
| Extraneous light or simulation of flame on burner start up | ● 4x flashes |
| Flame presence during pre-purging | ● 5x flashes |
| Loss of flame during operation: - faulty or soiled fuel valves - faulty or soiled flame detector - poor adjustment of burner | ● 7x flashes |
| Minimum air pressure switch opens during operation | ● 18x flashes |
| Wrong electrical connections | ● 19x flashes |
| Faulty control box | ● 20x flashes |

START UP CYCLE

RS 34/M MZ- 44/M MZ - 50/M MZ - 64/M MZ

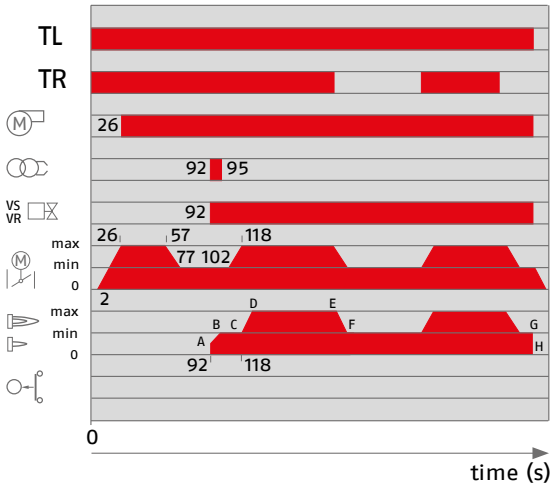

- 0s The TL remote control closes.
- 2-26s The servomotor opens the air-damper.
- 26-57s Pre-ventilation with air delivery at max output.
- 57-77s The air damper and the gas butterfly valve are positioned on MIN output.
- 92s The ignition electrode sparks.
- 94s Firing: the VS safety valve and the VR adjustment valve open.
- 118s The start up cycle of the control box is concluded.

RS 70/M - 100/M - 130/M - 190/M - 250/M MZ

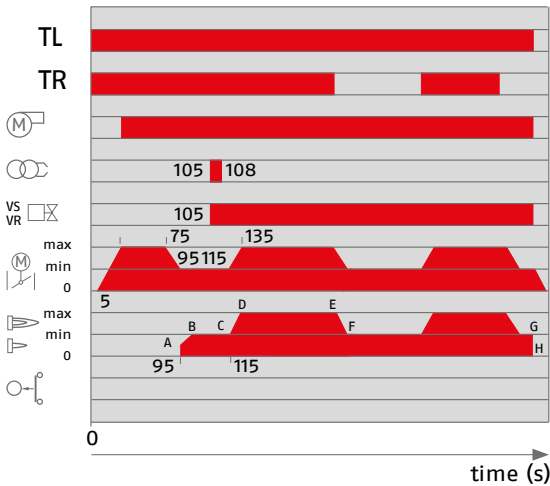

- 0s The TL remote control closes.
- 5-35s The servomotor opens the air-damper.
- 35-75s Pre-ventilation with air delivery at max output.
- 75-95s The air damper and the gas butterfly valve are positioned on MIN output.
- 105s The ignition electrode sparks.
- 105s Firing: the VS safety valve and the VR adjustment valve open.
- 115s The start up cycle of the control box is concluded.

Burner Wiring

All models of the RS/M burner series have an easily accessible control panel for the electrical components housing and wiring.

In particular the RS 34-44/M MZ models, thanks to the new structure concept, have a extremely clean electrical layout to optimise the commissioning and maintenance speed.

On these models the electrical connection are done by a Plug&Socket system, accessible from the external of the cover, and some of the main components as the servomotor, the air pressure switch, the electronic regulator (accessory) and the gas max pressure switch (accessory) are connected to the burner electrical wiring trough plugs & sockets system in order to facilitate the connection in case of maintenance.

The electrical wiring of all RS/M burner models are very easy to do following the wiring diagrams included in the instruction handbook.

Electrical connections must be made by qualified and skilled personnel, according to the local norms.



Example of the terminal board for electrical connections for the RS 70-100-130-190-250/M models.



Example of electrical components housing and Plug&Socket system for electrical connection of RS 34-44/M MZ.



The following table shows the supply lead sections and the type of fuse to be used.

| MODEL | V | F (A) | L (mm ²) |
|------------|-----|-------|----------------------|
| RS 34/M MZ | 230 | T6 | 1,5 |
| RS 44/M MZ | 230 | T6 | 1,5 |
| RS 44/M MZ | 230 | T6 | 1,5 |
| | 400 | T6 | 1,5 |
| RS 50/M MZ | 230 | T6 | 1,5 |
| | 400 | T6 | 1,5 |
| RS 64/M MZ | 230 | T10 | 1,5 |
| | 400 | T6 | 1,5 |
| RS 70/M | 230 | T10 | 1,5 |
| | 400 | T6 | 1,5 |

| MODEL | V | F (A) | L (mm ²) |
|-------------|-----|-----------------|----------------------|
| RS 100/M | 230 | T16 | 1,5 |
| | 400 | T10 | 1,5 |
| RS 130/M | 230 | T16 | 1,5 |
| | 400 | T10 | 1,5 |
| RS 150/M | 230 | T12 | 2,5 |
| | 400 | T10 | 2,5 |
| RS 190/M | 230 | T25 | 2,5 |
| | 400 | T25 | 2,5 |
| RS 250/M MZ | 230 | 25A aM - 40A gG | 6 |
| | 400 | 16A aM - 32A gG | 4 |

V = Electrical supply F = Fuse L = Lead section

Emissions

N₂O EMISSIONS (gas G20)

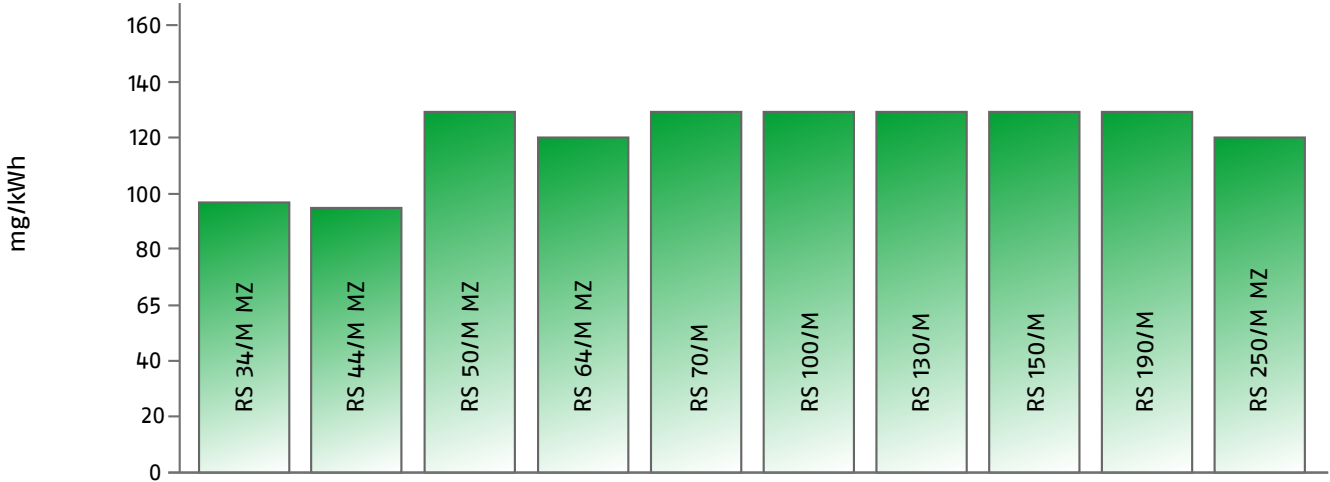

CO EMISSIONS (gas G20)

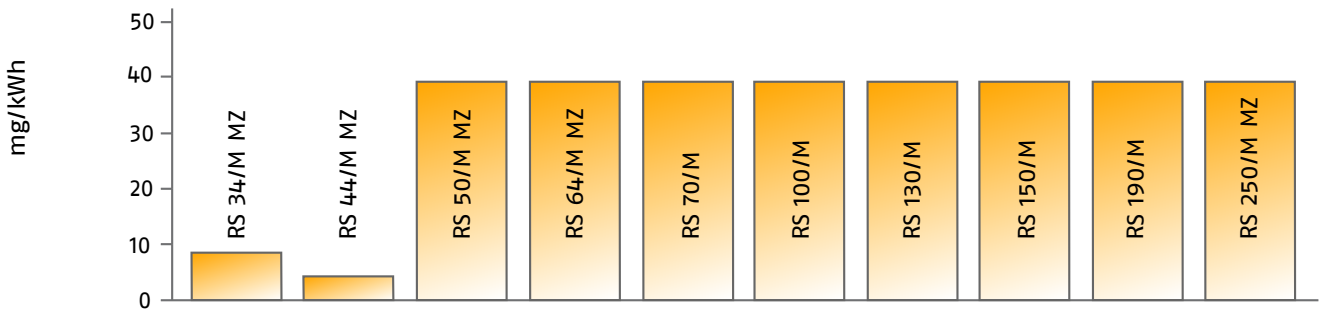

NOISE EMISSIONS

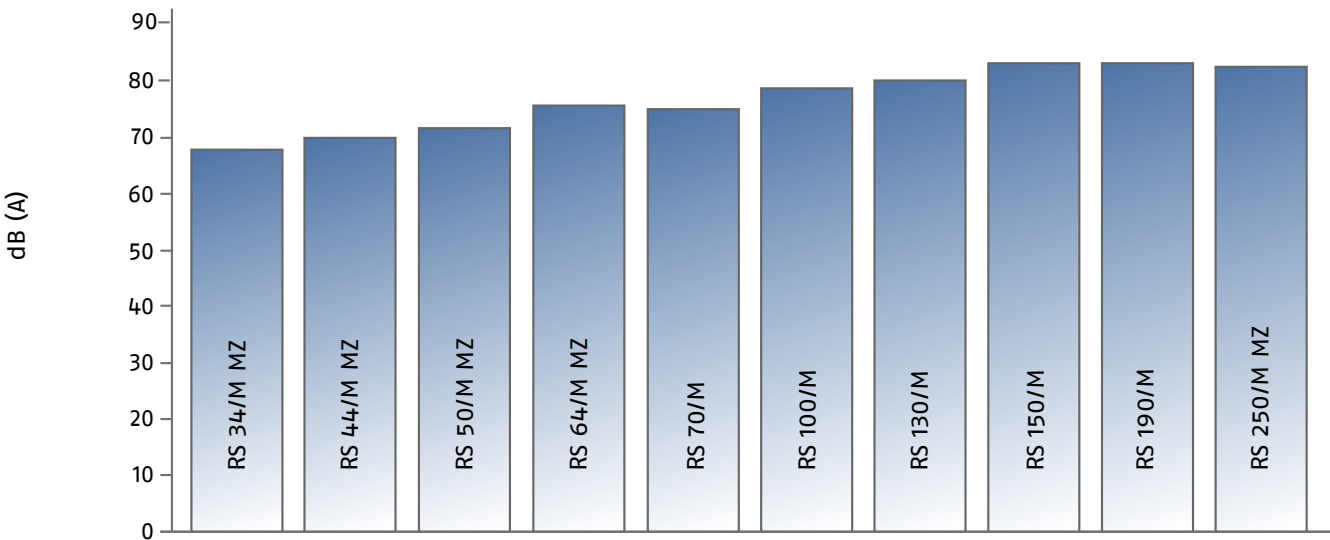

The noise emissions have been measured at the maximum output.

Overall Dimensions (mm)

BURNER

RS 34/M MZ - 44/M MZ

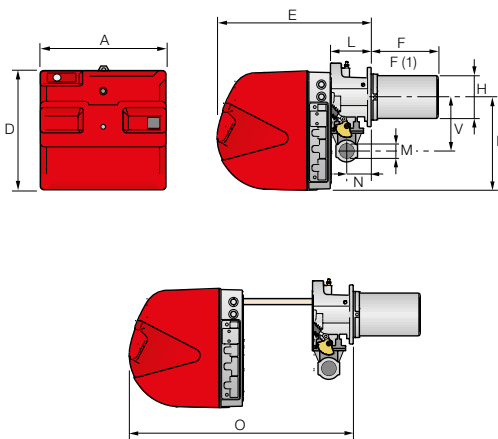

RS 50/M MZ

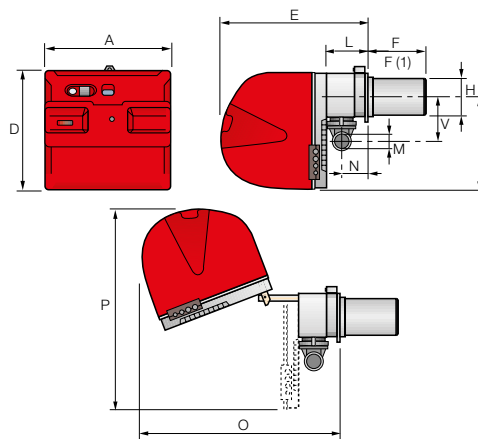

| MODEL | A | D | E | F - F ⁽¹⁾ | H | I | L | M | N | O | P | V |
|------------|-----|-----|-----|----------------------|-----|-----|-----|-------------------|-----|-----|-----|-----|
| RS 34/M MZ | 442 | 422 | 508 | 216 - 351 | 140 | 305 | 138 | 1 ^{11/2} | 84 | 780 | - | 177 |
| RS 44/M MZ | 442 | 422 | 508 | 216 - 351 | 152 | 305 | 138 | 1 ^{11/2} | 84 | 780 | - | 177 |
| RS 50/M MZ | 476 | 474 | 580 | 216 - 351 | 152 | 352 | 164 | 1 ^{11/2} | 108 | 810 | 719 | 168 |

(1) dimension with extended head

RS 64/M MZ

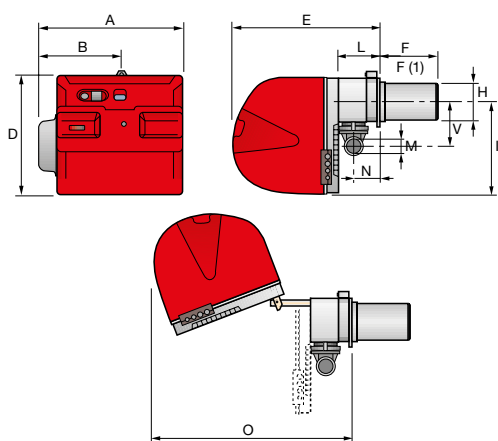

RS 70/M - 100/M - 130/M - 150/M - 190/M - 250/M MZ

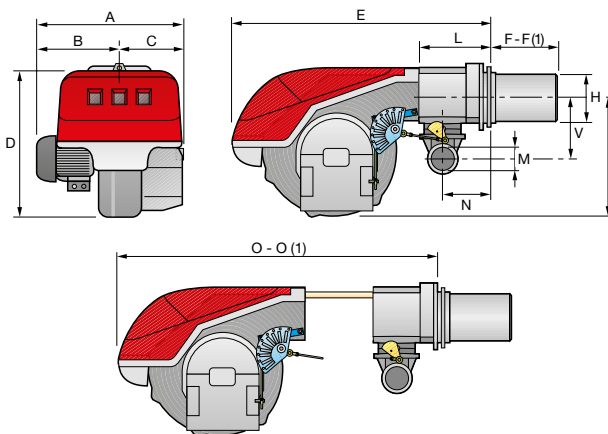

| MODEL | A | B | C | D | E | F - F ⁽¹⁾ | H | I | L | M | N | O - O ⁽¹⁾ | V |
|-------------|-----|-----|-----|-----|-----|----------------------|-----|-----|-----|----|-----|----------------------|-----|
| RS 64/M MZ | 533 | 300 | - | 490 | 640 | 250 - 385 | 179 | 352 | 222 | 2" | 134 | 870 - - | 221 |
| RS 70/M | 511 | 296 | 215 | 555 | 840 | 250 - 385 | 179 | 430 | 214 | 2" | 134 | 1161 - 1296 | 221 |
| RS 100/M | 527 | 312 | 215 | 555 | 840 | 250 - 385 | 179 | 430 | 214 | 2" | 134 | 1161 - 1296 | 221 |
| RS 130/M | 553 | 338 | 215 | 555 | 840 | 280 - 415 | 189 | 430 | 214 | 2" | 134 | 1161 - 1296 | 221 |
| RS 150/M | 675 | 370 | 305 | 590 | 840 | 280 - 415 | 189 | 435 | 214 | 2" | 134 | 1180 - 1315 | 221 |
| RS 190/M | 681 | 366 | 315 | 555 | 872 | 370 - 520 | 222 | 430 | 230 | 2" | 150 | 1328 - - | 221 |
| RS 250/M MZ | 732 | 427 | 305 | 555 | 872 | 370 - 520 | 222 | 430 | 230 | 2" | 150 | 1328 - - | 262 |

(1) dimension with extended head

BURNER - BOILER MOUNTING FLANGE

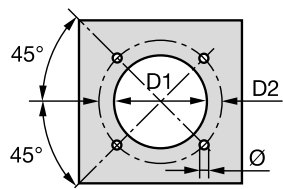

| MODEL | D1 | D2 | Ø |
|-------------|-----|---------|-----|
| RS 34/M MZ | 160 | 224 | M8 |
| RS 44/M MZ | 160 | 224 | M8 |
| RS 50/M MZ | 160 | 224 | M8 |
| RS 64/M MZ | 185 | 275-325 | M12 |
| RS 70/M | 185 | 275-325 | M12 |
| RS 100/M | 185 | 275-325 | M12 |
| RS 130/M | 195 | 275-325 | M12 |
| RS 150/M | 195 | 275-325 | M12 |
| RS 190/M | 230 | 325-368 | M16 |
| RS 250/M MZ | 230 | 325-368 | M16 |

PACKAGING

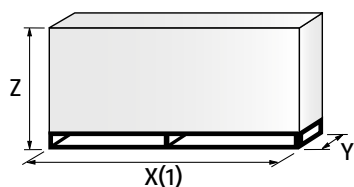

| MODEL | X (1) | Y | Z | kg |
|-------------|-----------|------|-----|-----|
| RS 34/M MZ | 1000 | 485 | 500 | 32 |
| RS 44/M MZ | 1000 | 485 | 500 | 33 |
| RS 50/M MZ | 1200 | 502 | 520 | 41 |
| RS 64/M MZ | 1200 | 580 | 520 | 42 |
| RS 70/M | 1405 | 700 | 660 | 70 |
| RS 100/M | 1405 | 700 | 660 | 73 |
| RS 130/M | 1405 | 700 | 660 | 76 |
| RS 150/M | 1400-1420 | 1000 | 660 | 110 |
| RS 190/M | 1400-1420 | 1000 | 660 | 115 |
| RS 250/M MZ | 1400-1420 | 1040 | 725 | 117 |

(1) dimension with standard and extended head

Installation Description

Installation, start up and maintenance must be carried out by qualified and skilled personnel.
All operations must be performed in accordance with the technical handbook supplied with the burner.

BURNER SETTING

All the burners have slide bars, for easier installation and maintenance.

After drilling the boilerplate, using the supplied gasket as a template, dismantle the blast tube from the burner and fix it to the boiler.

Adjust the combustion head.

Fit the gas train, choosing this on the basis of the maximum output of the boiler and considering the enclosed diagrams.

Refit the burner casing to the slide bars.

Close the burner, sliding it up to the flange.



ELECTRICAL CONNECTIONS AND START UP

Make the electrical connections to the boiler following the wiring diagrams included in the instruction handbook.

Turn the motor to check rotation direction (if it is a three-phase motor).

Perform a first ignition calibration on the gas train.

On start up, check:

- Gas pressure at the combustion head (to max. and min. output)
- Combustion quality, in terms of unburned substances and excess air.



BURNER MAINTENANCE

The maintenance of RS/M burners is very simple thanks to the sliding bars system that allows an easy access to the internal components.



In particular the RS 34-44/M MZ models have a new sliding bars system to make easier the access to the combustion head.

The RS 190/M and RS 250/M MZ have new reinforced sliding bars that make very strong the burner structure during maintenance.

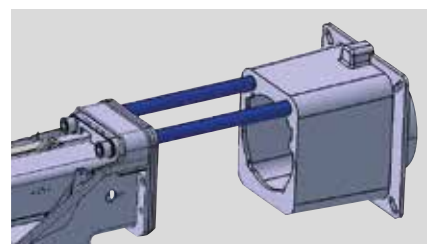

Burner accessories

Extended heads

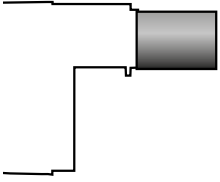

“Standard head” burners can be transformed into “extended head” versions, by using the special kit. The KITS available for the various burners, giving the original and the extended lengths, are listed below.

| BURNER | 'STANDARD HEAD' LENGTH (mm) | 'EXTENDED HEAD' LENGTH (mm) | KIT CODE |
|-------------|-----------------------------|-----------------------------|-----------|
| RS 34/M MZ | 216 | 351 | 3010428 |
| RS 44/M MZ | 216 | 351 | 3010429 |
| RS 50/M MZ | 216 | 351 | 3010078 |
| RS 64/M MZ | 250 | 385 | 3010427 |
| RS 70/M | 250 | 385 | 3010117 |
| RS 100/M | 250 | 385 | 3010118 |
| RS 130/M | 280 | 415 | 3010119 |
| RS 150/M | 280 | 415 | 20052186 |
| RS 190/M | 370 | 520 | 3010443 * |
| RS 250/M MZ | 370 | 520 | 3010412 |

* Kit to be used on burners recognizable by a serial number that is over or equal to 02426XXXXXX, for burners with a serial number that is under or equal to 02416XXXXXX please use the Kit coded 3010196

Spacer kit



If burner head penetration into the combustion chamber needs reducing, varying thickness spacers are available, as given in the following table:

| BURNER | SPACER THICKNESS S (mm) | KIT CODE |
|----------------------------------------------|-------------------------|----------|
| RS 34/M MZ - 44/M MZ - RS 50/M MZ | 110 | 3010095 |
| RS 64/M MZ - RS 70/M - 100/M - 130/M - 150/M | 135 | 3010129 |
| RS 190/M - 250/M MZ | 102 | 3000722 |

Continuous ventilation kit



If the burner requires continuous ventilation in the stages without flame, a special kit is available as given in the following table:

| BURNER | KIT CODE |
|---------------------------------------------------------------------|----------|
| RS 34/M MZ - 44/M MZ | 3010449 |
| RS 50/M MZ - 64/M MZ - 70/M - 100/M - 130/M - 150/M - 190/M - 250/M | 3010094 |

Sound proofing box

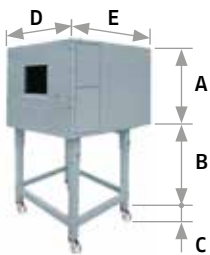

If noise emission needs reducing even further, sound-proofing boxes are available.

In case of generator heights, where a lower dimension “B” is required, ask for the Box Support Kit code 20065135. The useful dimensions are 40 mm less than the total dimensions indicated in the table (A, D, E). Not suitable for outdoor use.

| BURNER | BOX TYPE | A (mm) | B (mm) min-max | C (mm) | D (mm) | E (mm) | [dB(A)] (*) | BOX CODE |
|------------------------------------------------------------|----------|--------|----------------|--------|--------|--------|-------------|----------|
| RS 34/M MZ - 44/M MZ RS 50/M - 64/M MZ | C1/3 | 650 | 372 - 980 | 110 | 690 | 770 | 10 | 3010403 |
| RS 70/M - 100/M RS 130/M - 150/M RS 190/M - 250/M MZ | C4/5 | 850 | 160 - 980 | 110 | 980 | 930 | 10 | 3010404 |

(*) Average noise reduction according to EN 15036-1 standard

Accessories for modulating operation



To obtain modulating operation, the RS/M series of burners requires a regulator with three point outlet controls. The relative temperature or pressure probes fitted to the regulator must be chosen on the basis of the application.

The following table lists the accessories for modulating operation with their application range.

| BURNER | TYPE | CODE |
|----------------------------------------------------|----------|----------|
| RS 34/M MZ - 44/M MZ | RWF 50.2 | 20083339 |
| | RWF 55.5 | 20098541 |
| RS 50/M MZ - RS 64/M MZ | RWF 50.2 | 20082208 |
| | RWF 55.5 | 20099657 |
| RS 70/M - 100/M - 130/M - 150/M - 190/M - 250/M MZ | RWF 50.2 | 20099869 |
| | RWF 55.5 | 20099905 |

Probe



| BURNER | PROBE TYPE | RANGE (°C) (bar) | CODE |
|------------|--------------------|------------------|---------|
| All models | Temperature PT100 | -100 ÷ 500°C | 3010110 |
| | Pressure 4 ÷ 20 mA | 0 ÷ 2,5 bar | 3010213 |
| | Pressure 4 ÷ 20 mA | 0 ÷ 16 bar | 3010214 |
| | Pressure 4 ÷ 20 mA | 0 ÷ 25 bar | 3090873 |

Analog control signal converter



Modulating operation can also be obtained with an analog control signal converter and a feedback three-pole potentiometer.

Alternatively, the potentiometer can be used to check the servomotor position.

| BURNER | TYPE (INPUT SIGNAL) | CODE |
|-------------------------------------------------------|-------------------------------|-----------|
| RS 34/M MZ - 44/M MZ | 0/2 - 10 V (impedance 200 KΩ) | 3010410 |
| | 0/4 - 20 mA (impedance 250 Ω) | |
| RS 50/M MZ - RS 64/M MZ | 0/2 - 10 V (impedance 200 KΩ) | on demand |
| | 0/4 - 20 mA (impedance 250 Ω) | |
| RS 70/M - 100/M - 130/M - 150/M - RS 190/M - 250/M MZ | 0/2 - 10 V (impedance 200 KΩ) | 3010415 |
| | 0/4 - 20 mA (impedance 250 Ω) | |

Potentiometer kit



| BURNER | KIT CODE |
|----------------------------------------------------|----------|
| RS 34/M MZ - 44/M MZ | 3010420 |
| RS 50/M MZ - RS 64/M MZ | 3010109 |
| RS 70/M - 100/M - 130/M - 150/M - 190/M - 250/M MZ | 3010416 |

Connection flange kit

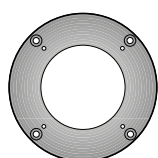

A kit is available for use where the burner opening on the boiler is of excessive diameter.

| BURNER | KIT CODE |
|-----------------------------------|----------|
| RS 34/M MZ - 44/M MZ - RS 50/M MZ | 3010138 |

LPG kit

For burning LPG gas, a special kit is available to be fitted to the combustion head on the burner, as given in the following table:

| BURNER | KIT CODE FOR 'STANDARD HEAD' | KIT CODE FOR 'EXTENDED HEAD' |
|-------------|---------------------------------|---------------------------------|
| RS 34/M MZ | 3010423 | 3010423 |
| RS 44/M MZ | 3010424 | 3010424 |
| RS 50/M MZ | 20008173 | 20008173 |
| RS 64/M MZ | 3010434 | 3010435 |
| RS 70/M | 20008175 | 20008176 |
| RS 100/M | 20008177 | 20008178 |
| RS 130/M | 20008179 | 20008180 |
| RS 150/M | 20050064 | 20050065 |
| RS 190/M | 3010166 | 3010166 |
| RS 250/M MZ | 3010411 | 3010411 |

Town gas kit

For burning Town gas, a special kit is available:

| BURNER | KIT CODE FOR HEAD' (*) |
|-------------|------------------------|
| RS 34/M MZ | 3010502 |
| RS 44/M MZ | 3010503 |
| RS 50/M MZ | 3010285 |
| RS 70/M | 3010286 |
| RS 100/M | 3010287 |
| RS 130/M | 3010288 |
| RS 190/M | 3010297 |
| RS 250/M MZ | 3010472 |

(*) Without CE certification

Vibration reduction kit

The kit allow you to improve flame stability in some applications, where the boiler/flue assembly is liable to resonate.

| BURNER | KIT CODE |
|-------------------------------|----------|
| RS 50/M MZ TC - RS 50/M MZ TL | 3010200 |
| RS 70/M TC - RS 70/M TL | 3010201 |
| RS 100/M TC - RS 100/M TL | 3010202 |
| RS 130/M TC | 3010373 |
| RS 130/M TL | 3010374 |
| RS 190/M TC | 3010375 |

Ground fault interrupter kit



A "Ground fault interrupter kit" is available as a safety device for electrical system fault.

| BURNER | KIT CODE |
|-------------------------------------------------------|----------|
| RS 34/M MZ - 44/M MZ | 3010448 |
| RS 50/M MZ - RS 64/M MZ | 3010321 |
| RS 70/M - 100/M - 130/M - 150/M - 190/M - RS 250/M MZ | 3010329 |

Gas max pressure switch kit

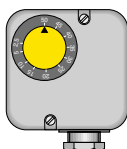

If necessary a Gas max pressure Switch kit is available and connectable to the burner electrical wiring through Plugs & Sockets system.

| BURNER (*) | KIT CODE |
|----------------------|----------|
| RS 34/M MZ - 44/M MZ | 3010418 |

(*) Gas max pressure switch is installed as a standard on RS 50/M MZ - 64/M MZ - 70/M - 100/M - 130/M - 190/M - 250/M MZ

Volt free contact kit



A volt free contact kit is available for installation onto the burner. It can be used for a remote interface between burner operating signals. Every burner can be equipped with a single kit for a remote check of the flame presence signal or the burner lockout indication.

| BURNER | KIT CODE |
|------------------------------------------|----------|
| RS 34/M MZ - 44/M MZ - 50/M MZ - 64/M MZ | 3010419 |

PC interface kit



To connect the control box to a personal computer for the transmission of operation, fault signals and detailed service information, an interface adapter with PC software are available.

| BURNER | KIT CODE |
|------------|----------|
| All models | 3002719 |

DN80 gas flange kit

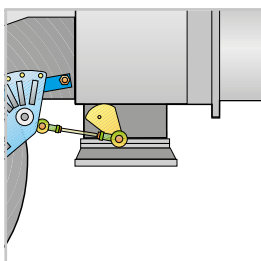

To modify the standard 2" burner gas input connection in to DN80 connection, a specific gas flange is available.

| BURNER | KIT CODE |
|------------|----------|
| All models | 3010439 |

Post-ventilation kit

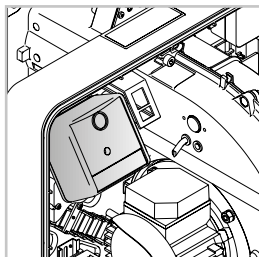

To have 20 s ventilation after opening of thermostats chain, a special kit is available.

| BURNER | KIT CODE |
|----------------------|----------|
| RS 34/M MZ - 44/M MZ | 3010451 |

Hours counter kit

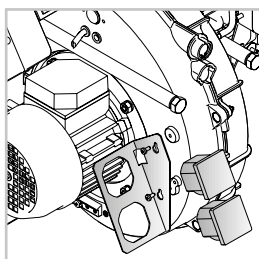

To measure the burner working time a hours counter kit is available.

| BURNER | KIT CODE |
|----------------------|----------|
| RS 34/M MZ - 44/M MZ | 3010450 |

Protection kit (electromagnetic interferences)

When the burner is installed in a room particularly subject to electromagnetic interference (signals emitted over 10 V/m) due for example to INVERTER presence or in systems where the lengths of the thermostat connections is over 20 meters, this specific protection kit is available as an interface between the thermostatic controls and the burner.

| BURNER | KIT CODE |
|------------|----------|
| All models | 3010386 |

Head kit for "reverse flame chamber"



In certain cases, the use of the burner on reverse flame boilers can be improved by using an additional cylinder.

| BURNER | STANDARD HEAD LENGTH WITH CYLINDER (mm) | EXTENDED HEAD LENGTH WITH CYLINDER (mm) | KIT CODE (*) |
|----------|-----------------------------------------|-----------------------------------------|--------------|
| RS 190/M | 493 | - | 3010241 |









(*) EC certification in progress

Gas train accessories

Adapters

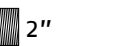
In certain cases, an adapter must be fitted between the gas train and the burner, when the diameter of the gas train is different from the set diameter of the burner.

Below are given the available adapters; please see on the Gas Train list the correct adapter codes to select.

| ADAPTER | LENGTH mm | ADAPTER CODE |
|-------------------------------------------------------------------------------------------------------------------------------------------------------------------------------------|-----------|--------------|
| 2"  1" 1/2 | 70 | 3000822 |
| 3/4"  1" 1/2 | 31 | 3000824 |
| DN 65  2" 1/2  2" | 300 | 3000825 |
| DN 80  2" 1/2  2" | 300 | 3000826 |
| 1" 1/2  2" | 35 | 3000843 |
| 1" 1/4  1" 1/2 | 35 | 3010124 |
| 1" 1/4  2" | 35 | 3010126 |

Stabiliser spring



Accessory springs are available to vary the pressure range of the gas train stabilisers.

The following table shows these accessories with their application range. Please refer to the technical manual for the correct choice of spring.

| GAS TRAIN | SPRING COLOUR | SPRING PRESSURE RANGE mbar | SPRING CODE |
|-----------------------------------|---------------|----------------------------|-------------|
| MBC 1900/1 - 3100/1 MBC 5000/1 | WHITE | 4 - 20 | 3010381 |
| | RED | 20 - 40 | 3010382 |
| | BLACK | 40 - 80 | 3010383 |
| | GREEN | 80 - 150 | 3010384 |
| CB 512/1 | RED | 25 - 55 | 3010131 |
| | BLACK | 60 - 110 | 3010157 |
| | PINK | 90 - 150 | 3090486 |
| CB 520/1 - 525/1 | RED | 25 - 55 | 3010132 |
| | BLACK | 60 - 110 | 3010158 |
| | PINK | 90 - 150 | 3090487 |
| CB 5065/1 - 5080/1 | RED | 25 - 55 | 3010133 |
| | BLACK | 60 - 110 | 3010135 |
| | PINK | 100 - 150 | 3090456 |
| | GREY | 140 - 200 | 3090992 |

Seal control kit

To test the valve seals on the gas train, a special "seal control kit" is available. The valve seal control device is compulsory (EN 676) on gas trains to burners with a maximum output over 1200 kW. The seal control is type VPS 504.

| GAS TRAIN | KIT CODE FOR 50 Hz OPERATION | KIT CODE FOR 60 Hz OPERATION |
|------------------|-----------------------------------------|-----------------------------------------|
| MB/1 type | 3010123 | 20050030 |
| MBC/1 type | 3010367 | 20029057 |
| CB/1 type | 3010367 | 20029057 |

Specification

DESIGNATION OF SERIES

A specific index guides your choice of burner from the various models available in the RS/M C13 series. Below is a clear and detailed specification description of the product.

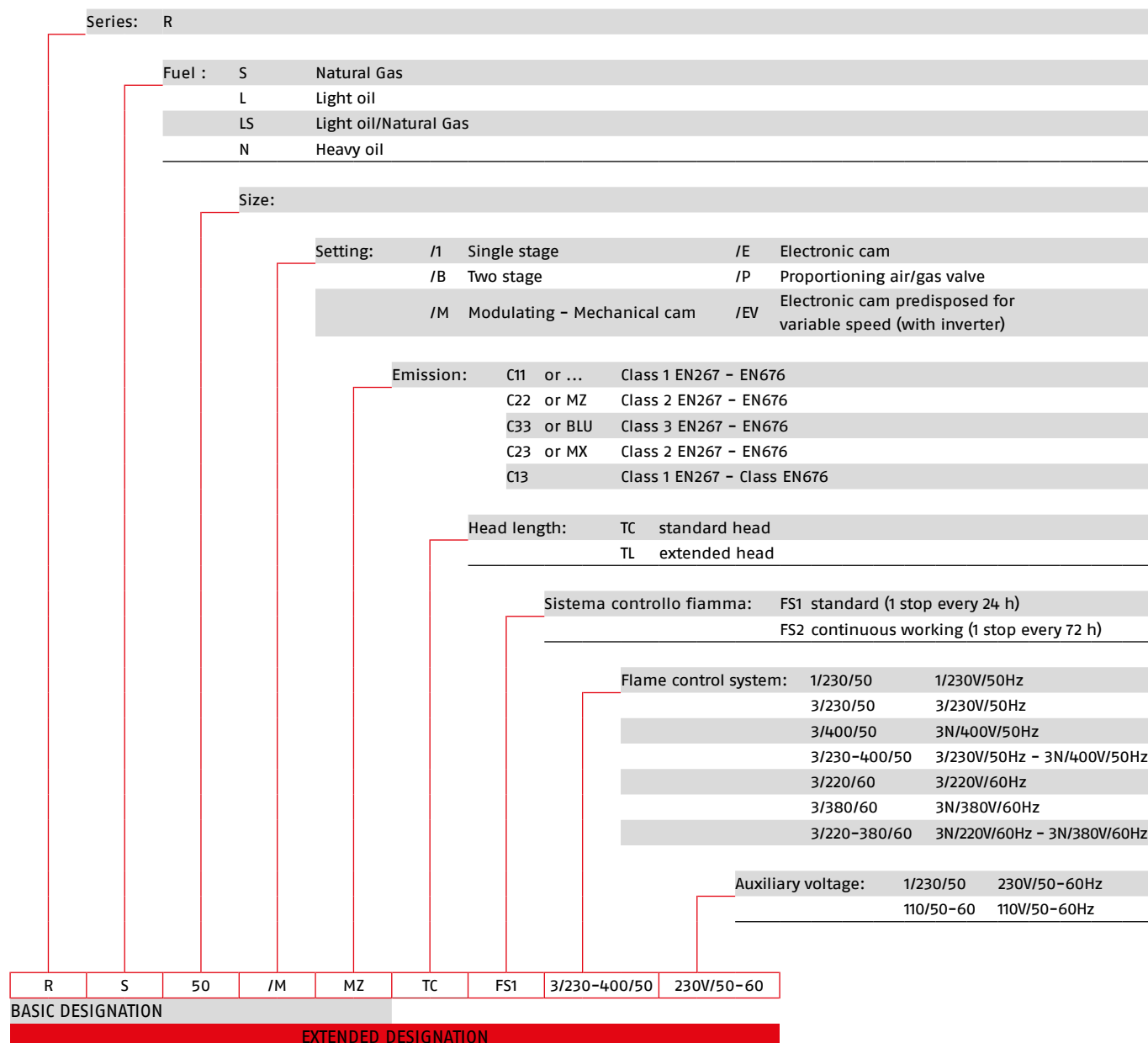

AVAILABLE BURNER MODELS

| | | | | | |
|-----------|-------------|----|-----|-----------------|--------------|
| 3788710 | RS 34/M MZ | TC | FS1 | 1/230/50-60 | 230/50-60 |
| 3788711 | RS 34/M MZ | TL | FS1 | 1/230/50-60 | 230/50-60 |
| 3788810 | RS 44/M MZ | TC | FS1 | 1/230/50-60 | 230/50-60 |
| 3788811 | RS 44/M MZ | TL | FS1 | 1/230/50-60 | 230/50-60 |
| 3788840 | RS 44/M MZ | TC | FS1 | 3/230-400/50-60 | 230/50-60 |
| 3788841 | RS 44/M MZ | TL | FS1 | 3/230-400/50-60 | 230/50-60 |
| 3781622 | RS 50/M MZ | TC | FS1 | 3/230-400/50 | 230/50-60 |
| 3781623 | RS 50/M MZ | TL | FS1 | 3/230-400/50 | 230/50-60 |
| 3781682 | RS 50/M MZ | TC | FS1 | 3/220-380/60 | 230/50-60 |
| 3781683 | RS 50/M MZ | TL | FS1 | 3/220-380/60 | 230/50-60 |
| 3788910 | RS 64/M MZ | TC | FS1 | 3/230-400/50 | 230/50-60 |
| 3788911 | RS 64/M MZ | TL | FS1 | 3/230-400/50 | 230/50-60 |
| 3788920 | RS 64/M MZ | TC | FS2 | 3/230-400/50 | 230/50-60 |
| 3788921 | RS 64/M MZ | TL | FS2 | 3/230-400/50 | 230/50-60 |
| 3788980 | RS 64/M MZ | TC | FS1 | 3/220-380/60 | 230/50-60 |
| 3788981 | RS 64/M MZ | TL | FS1 | 3/220-380/60 | 230/50-60 |
| 3789610 | RS 70/M | TC | FS1 | 3/230-400/50 | 230/50-60 |
| 3787040 | RS 70/M | TC | FS1 | 3/230-400/50 | 230/50-60 ID |
| 3789611 | RS 70/M | TL | FS1 | 3/230-400/50 | 230/50-60 |
| 3787041 | RS 70/M | TL | FS1 | 3/230-400/50 | 230/50-60 ID |
| 3866203 | RS 70/M | TC | FS1 | 3/230-400/50 | 230/50-60 |
| on demand | RS 70/M | TL | FS1 | 3/230-400/50 | 230/50-60 |
| 3787082 | RS 70/M | TC | FS1 | 3/220-380/60 | 230/50-60 |
| 3787083 | RS 70/M | TL | FS1 | 3/220-380/60 | 230/50-60 |
| 3789710 | RS 100/M | TC | FS1 | 3/230-400/50 | 230/50-60 |
| 3787240 | RS 100/M | TC | FS1 | 3/230-400/50 | 230/50-60 ID |
| 3789711 | RS 100/M | TL | FS1 | 3/230-400/50 | 230/50-60 |
| 3787241 | RS 100/M | TL | FS1 | 3/230-400/50 | 230/50-60 ID |
| 3866204 | RS 100/M | TC | FS1 | 3/230-400/50 | 230/50-60 |
| on demand | RS 100/M | TL | FS1 | 3/230-400/50 | 230/50-60 |
| 3787282 | RS 100/M | TC | FS1 | 3/380/60 | 230/50-60 |
| 3787283 | RS 100/M | TL | FS1 | 3/220-380/60 | 230/50-60 |
| 3789810 | RS 130/M | TC | FS1 | 3/230-400/50 | 230/50-60 |
| 3787440 | RS 130/M | TC | FS1 | 3/230-400/50 | 230/50-60 ID |
| 3789811 | RS 130/M | TL | FS1 | 3/230-400/50 | 230/50-60 |
| 3787441 | RS 130/M | TL | FS1 | 3/230-400/50 | 230/50-60 ID |
| 3866205 | RS 130/M | TC | FS1 | 3/230-400/50 | 230/50-60 |
| on demand | RS 130/M | TL | FS1 | 3/230-400/50 | 230/50-60 |
| 3787482 | RS 130/M | TC | FS1 | 3/220-380/60 | 230/50-60 |
| 3787483 | RS 130/M | TL | FS1 | 3/220-380/60 | 230/50-60 |
| 20044638 | RS 150/M | TC | FS1 | 3/400/50 | 230/50-60 |
| 20044639 | RS 150/M | TL | FS1 | 3/400/50 | 230/50-60 |
| 20051315 | RS 150/M | TC | FS1 | 3/230/50 | 230/50-60 |
| 20051316 | RS 150/M | TL | FS1 | 3/230/50 | 230/50-60 |
| 3787623 | RS 190/M | TC | FS1 | 3/400/50 | 230/50-60 |
| 3787622 | RS 190/M | TC | FS1 | 3/230/50 | 230/50-60 |
| 3787640 | RS 190/M | TC | FS1 | 3/400/50 | 230/50-60 ID |
| 20011675 | RS 190/M | TC | FS1 | 3/230/50 | 230/50-60 ID |
| 3866206 | RS 190/M | TC | FS1 | 3/400/50 | 230/50-60 |
| on demand | RS 190/M | TL | FS1 | 3/400/50 | 230/50-60 |
| 20011708 | RS 190/M | TC | FS1 | 3/230/50 | 230/50-60 |
| 3787682 | RS 190/M | TC | FS1 | 3/220-380/60 | 230/50-60 |
| 3787681 | RS 190/M | TC | FS1 | 3/220/60 | 220/60 |
| 3788410 | RS 250/M MZ | TC | FS1 | 3/400/50 | 230/50-60 |
| 3788411 | RS 250/M MZ | TL | FS1 | 3/400/50 | 230/50-60 |
| 3788440 | RS 250/M MZ | TC | FS1 | 3/230/50 | 230/50-60 |
| 3788441 | RS 250/M MZ | TL | FS1 | 3/230/50 | 230/50-60 |
| 3788420 | RS 250/M MZ | TC | FS2 | 3/400/50 | 230/50-60 |
| 3788421 | RS 250/M MZ | TL | FS2 | 3/400/50 | 230/50-60 |
| 3788450 | RS 250/M MZ | TC | FS2 | 3/230/50 | 230/50-60 |
| 3788451 | RS 250/M MZ | TL | FS2 | 3/230/50 | 230/50-60 |
| 20008162 | RS 250/M MZ | TC | FS1 | 3/220-380/60 | 220/60 |

PRODUCT SPECIFICATION

RS 34/M MZ – 44/M MZ models

Monoblock forced draught gas burner with two stage progressive or modulating operation, with a specific kit, fully automatic, made up of:

- Air suction circuit **with sound proofing material**
- High performance fan with straight blades
- Air damper for air flow setting and butterfly valve for regulating fuel output controlled by a servomotor with variable cam
- Starting motor at 2800 rpm, single-phase / 230V / 50-60Hz or three-phase / 230-400V / 50-60Hz
- Combustion head, that can be set on the basis of required output, fitted with:
 - stainless steel end cone, resistant to corrosion and high temperatures
 - ignition electrodes
 - ionisation probe
 - gas distributor
 - flame stability disk
- Exclusive patented HCS (Housing Cooling System) with high thermal insulation and air circulation with continuous air volume refresh for an active cooling system and avoid heat transfer to the electrical component housing
- Minimum air pressure switch stops the burner in case of insufficient air quantity at the combustion head
- Microprocessor-based burner safety control box, with diagnostic functions
- Plugs and Sockets for electrical connection, accessible from the external of the cover
- Burner on/off selection switch
- Manual or automatic output increase/decrease selection switch
- Flame inspection window
- Slide bars for easier installation and maintenance
- Protection filter against radio interference
- IP 40 electric protection level.

Standard equipment:

- 1 gas train flange
- 1 flange gasket
- 4 screws for fixing the flange
- 1 thermal screen
- 4 screws for fixing the burner flange to the boiler
- 3 plugs for electrical connection (RS 34-44/M MZ single-phase)
- 4 plugs for electrical connection (RS 44/M MZ three-phase)
- Instruction handbook for installation, use and maintenance
- Spare parts catalogue.

RS 50/M MZ – 64/M MZ – 70/M – 100/M – 130/M – 150/M – 190/M – 250/M MZ models

Monoblock forced draught gas burner with two stage progressive or modulating operation, with a specific kit, fully automatic, made up of:

- Air suction circuit lined with sound-proofing material
- Fan with reverse curve blades (RS 50 – 70 – 100 – 130/M models) or straight blades (RS 64/M MZ – 150/M – 190/M – 250/M MZ models)
- Air damper for air flow setting and butterfly valve for regulating fuel output controlled by a servomotor with variable cam
- Starting motor at 2800 rpm, three-phase 400V with neutral, 50Hz
- Combustion head, that can be set on the basis of required output, fitted with:
 - stainless steel end cone, resistant to corrosion and high temperatures
 - ignition electrodes
 - ionisation probe
 - gas distributor
 - flame stability disk
- Maximum gas pressure switch to stop the burner in the case of excess pressure on the fuel supply line
- Minimum air pressure switch stops the burner in case of insufficient air quantity at the combustion head
- Microprocessor-based burner safety control box, with diagnostic functions
- Burner on/off selection switch
- Manual or automatic output increase/decrease selection switch
- Flame inspection window
- Slide bars for easier installation and maintenance
- Protection filter against radio interference
- IP 44 electric protection level.

Standard equipment:

- 1 gas train flange
- 1 flange gasket
- 4 screws for fixing the flange
- 1 thermal screen
- 4 screws for fixing the burner flange to the boiler
- Wiring loom fittings for the electrical connection (RS 64-50/M MZ)
- 2 slide bar extensions (for extended head models and RS 150-190/M models)
- Instruction handbook for installation, use and maintenance
- Spare parts catalogue.

Riello Burners a world of experience in every burner we sell.



[1]

Across the world, Riello sets the standard in reliable and high efficiency burner technology.

With burner capacity from 5 kW to 48 MW, Riello gas, oil, dual fuel and Low Nox burners deliver unbeatable performance across the full range of residential and commercial heating applications, as well as in industrial processes.

With headquarter in Legnago, Italy, Riello has been manufacturing premium quality burners for over 90 year. The manufacturing plant is equipped with the most innovative systems of assembling lines and modern manufacturing cells for a quick and flexible response to the market.



[2]

Besides, the Riello Combustion Research Centre, located in Angiari, Italy, represents one of the most modern facility in Europe and one of the most advanced in the world for the development of the combustion technology.

Today, the company's presence on worldwide markets is distinguished by a well-constructed and efficient sales network, alongside many important Training Centres located in various countries to meet its customers' needs. Riello has 13 operational branches abroad (in Europe, America and Asia), with customers in over 60 countries.

[1] BURNERS PRODUCTION PLANT
S. PIETRO, LEGNAGO (VERONA) - ITALIA

[2] HEADQUARTER BURNERS DIVISION
S. PIETRO, LEGNAGO (VERONA) - ITALIA

RIELLO S.p.A. - 37045 Legnago (VR) - Italy
tel. +39 0442 630111 - fax: +39 0442 21980
www.riello.com

Since the Company is constantly engaged in the production improvement, the aesthetic and dimensional features, the technical data, the equipment and the accessories can be changed. This document contains confidential and proprietary information of RIELLO S.p.A. Unless authorised, this information shall not be divulged, nor duplicated in whole or in part.

RIELLO