

**GB** Dual fuel light oil / gas burners

Progressive two-stage or modulating operation



CODE	MODEL	TYPE
20073915	RLS 68/E MX	779T1
20073918	RLS 120/E MX	780T1



**Translation of the original instructions**

<b>1</b>	<b>Information and general warnings.....</b>	<b>3</b>
1.1	Information about the instruction manual .....	3
1.1.1	Introduction.....	3
1.1.2	General dangers.....	3
1.1.3	Other symbols .....	3
1.1.4	Delivery of the system and the instruction manual .....	4
1.2	Guarantee and responsibility.....	4
<b>2</b>	<b>Safety and prevention.....</b>	<b>5</b>
2.1	Introduction.....	5
2.2	Personnel training .....	5
<b>3</b>	<b>Technical description of the burner .....</b>	<b>6</b>
3.1	Burner designation .....	6
3.2	Models available.....	6
3.3	Burner categories - Countries of destination .....	7
3.4	Technical data .....	7
3.5	Electrical data.....	7
3.6	Maximum dimensions.....	8
3.7	Firing rates .....	9
3.8	Test boiler.....	9
3.9	Commercial boilers.....	10
3.10	Burner equipment.....	10
3.11	Burner description .....	11
3.12	Flame control (LMV 26...)	12
3.12.1	Operation sequence of the burner (gas operation) .....	14
3.12.2	Operation sequence of the burner (light oil operation) .....	15
3.12.3	List of the phases (gas operation) .....	16
3.12.4	List of the phases (light oil operation).....	16
3.13	Operator panel operation .....	16
3.13.1	Description of the symbols on the display .....	17
3.13.2	Description of the buttons.....	17
3.14	Servomotors .....	18
<b>4</b>	<b>Installation .....</b>	<b>19</b>
4.1	Notes on safety for the installation .....	19
4.2	Handling .....	19
4.3	Preliminary checks .....	19
4.4	Operating position .....	20
4.5	Preparing the boiler .....	20
4.5.1	Boring the boiler plate .....	20
4.5.2	Blast tube length.....	20
4.6	Securing the burner to the boiler .....	21
4.7	Nozzle .....	22
4.7.1	Recommended nozzles.....	22
4.7.2	Nozzle installation .....	22
4.7.3	Removing the nozzles .....	23
4.8	Pressure variator .....	23
4.9	Combustion head adjustment.....	24
4.10	Electrodes adjustment.....	24
4.11	Closing the burner .....	24
4.12	Light oil supply.....	25
4.12.1	Double-pipe circuit.....	25
4.12.2	The loop circuit .....	25
4.12.3	Hydraulic connections .....	26
4.13	Burner start-up .....	26
4.13.1	Pump .....	27
4.13.2	Priming pump .....	27
4.14	Gas feeding .....	28
4.14.1	Gas feeding line (Example) - Please refer to the gas train documentation for more information .....	28
4.14.2	Gas pressure.....	29
4.15	Electrical wiring .....	30
4.15.1	Supply cables and external connections passage .....	30

<b>5</b>	<b>Start-up, calibration and operation of the burner</b> .....	<b>31</b>
5.1	Notes on safety for the first start-up .....	31
5.2	Adjustments prior to ignition (light oil) .....	31
5.2.1	Nozzle .....	31
5.2.2	Combustion head .....	31
5.2.3	Pump pressure .....	31
5.2.4	Fan damper .....	31
5.3	Operations before start-up (gas) .....	31
5.4	Burner start-up .....	32
5.5	Change of fuel .....	32
5.6	Burner adjustment .....	33
5.6.1	Gas/air delivery adjustment .....	33
5.6.2	Light oil/air delivery adjustment .....	33
5.7	Final calibration of the pressure switches .....	33
5.7.1	Air pressure switch .....	33
5.7.2	Maximum gas pressure switch .....	34
5.7.3	Minimum gas pressure switch .....	34
5.7.4	PVP pressure switch kit .....	34
5.7.5	Minimum oil pressure switch .....	35
5.7.6	Maximum oil pressure switch .....	35
5.8	Visualisation and programming mode .....	36
5.8.1	Normal mode .....	36
5.8.2	Info mode .....	37
5.8.3	Service mode .....	38
5.8.4	Parameters Mode .....	38
5.9	Parameter modification procedure .....	40
5.10	Start-up procedure .....	42
5.11	Backup / Restore procedure .....	44
5.11.1	Backup .....	44
5.11.2	Restore .....	45
5.12	List of parameters .....	46
5.13	Operation .....	51
5.14	Ignition failure .....	51
5.15	Burner flame goes out during operation .....	52
5.16	Stopping of the burner .....	52
5.17	Measuring the flame signal .....	52
5.18	Final checks (with burner operating) .....	52
<b>6</b>	<b>Maintenance</b> .....	<b>53</b>
6.1	Notes on safety for the maintenance .....	53
6.2	Maintenance programme .....	53
6.2.1	Maintenance frequency .....	53
6.2.2	Safety test - with gas ball valve closed .....	53
6.2.3	Checking and cleaning .....	53
6.2.4	Checking the air and gas pressure on the combustion head .....	55
6.2.5	Safety components .....	55
6.3	Opening the burner .....	56
6.4	Closing the burner .....	56
<b>7</b>	<b>Faults - Probable causes - Solutions</b> .....	<b>57</b>
7.1	List of error codes .....	57
<b>A</b>	<b>Appendix - Accessories</b> .....	<b>64</b>
<b>B</b>	<b>Appendix - Electrical panel layout</b> .....	<b>65</b>

**1 Information and general warnings**

**1.1 Information about the instruction manual**

**1.1.1 Introduction**

The instruction manual supplied with the burner:

- is an integral and essential part of the product and must not be separated from it; it must therefore be kept carefully for any necessary consultation and must accompany the burner even if it is transferred to another owner or user, or to another system. If the manual is lost or damaged, another copy must be requested from the Technical Assistance Service of the area;
- is designed for use by qualified personnel;
- offers important indications and instructions relating to the installation safety, start-up, use and maintenance of the burner.

**Symbols used in the manual**

In some parts of the manual you will see triangular DANGER signs. Pay great attention to these, as they indicate a situation of potential danger.

**1.1.2 General dangers**

The **dangers** can be of **3 levels**, as indicated below.



Maximum danger level!  
This symbol indicates operations which, if not carried out correctly, cause serious injury, death or long-term health risks.



This symbol indicates operations which, if not carried out correctly, may cause serious injury, death or long-term health risks.



This symbol indicates operations which, if not carried out correctly, may cause damage to the machine and/or injury to people.

**1.1.3 Other symbols**



**DANGER: LIVE COMPONENTS**  
This symbol indicates operations which, if not carried out correctly, lead to electric shocks with lethal consequences.



**DANGER: FLAMMABLE MATERIAL**  
This symbol indicates the presence of flammable materials.



**DANGER: BURNING**  
This symbol indicates the risks of burns due to high temperatures.



**DANGER: CRUSHING OF LIMBS**  
This symbol indicates the presence of moving parts: danger of crushing of limbs.



**WARNING: MOVING PARTS**

This symbol indicates that you must keep limbs away from moving mechanical parts; danger of crushing.



**DANGER: EXPLOSION**

This symbol signals places where an explosive atmosphere may be present. An explosive atmosphere is defined as a mixture - under atmospheric conditions - of air and flammable substances in the form of gases, vapours, mist or dust in which, after ignition has occurred, combustion spreads to the entire unburned mixture.



**PERSONAL PROTECTION EQUIPMENT**

These symbols indicate the equipment that must be worn and kept by the operator for protection against threats against safety and/or health while at work.



**OBLIGATION TO ASSEMBLE THE COVER AND ALL THE SAFETY AND PROTECTION DEVICES**

This symbol signals the obligation to reassemble the cover and all the safety and protection devices of the burner after any maintenance, cleaning or checking operations.



**ENVIRONMENTAL PROTECTION**

This symbol gives indications for the use of the machine with respect for the environment.



**IMPORTANT INFORMATION**

This symbol indicates important information that you must bear in mind.

- This symbol indicates a list.

**Abbreviations used**

Ch.	Chapter
Fig.	Figure
Page	Page
Sec.	Section
Tab.	Table

**1.1.4 Delivery of the system and the instruction manual**

When the system is delivered, it is important that:

- The instruction manual is delivered to the user by the system manufacturer, with the recommendation to keep it in the room where the heat generator is to be installed.
- The instruction manual shows:
  - the serial number of the burner;

.....

- the address and telephone number of the nearest Assistance Centre;

.....

.....

.....

- The system supplier must carefully inform the user about:
  - the use of the system;
  - any further tests that may be required before activating the system;
  - maintenance, and the need to have the system checked at least once a year by a representative of the manufacturer or another specialised technician.
 To ensure a periodic check, the manufacturer recommends the drawing up of a Maintenance Contract.

**1.2 Guarantee and responsibility**

The manufacturer guarantees its new products from the date of installation, in accordance with the regulations in force and/or the sales contract. At the moment of the first start-up, check that the burner is integral and complete.



**WARNING**

Failure to observe the information given in this manual, operating negligence, incorrect installation and carrying out of non authorised modifications will result in the annulment by the manufacturer of the guarantee that it supplies with the burner.

In particular, the rights to the guarantee and the responsibility will no longer be valid, in the event of damage to things or injury to people, if such damage/injury was due to any of the following causes:

- incorrect installation, start-up, use and maintenance of the burner;
- improper, incorrect or unreasonable use of the burner;
- intervention of unqualified personnel;
- carrying out of unauthorised modifications on the equipment;
- use of the burner with safety devices that are faulty, incorrectly applied and/or not working;
- installation of untested supplementary components on the burner;
- powering of the burner with unsuitable fuels;
- faults in the fuel supply system;
- continuation of use of the burner when a fault has occurred;
- repairs and/or overhauls incorrectly carried out;
- modification of the combustion chamber with inserts that prevent the regular development of the structurally established flame;
- insufficient and inappropriate surveillance and care of those burner components most likely to be subject to wear and tear;
- use of non-original components, including spare parts, kits, accessories and optional;
- force majeure.

**The manufacturer furthermore declines any and every responsibility for the failure to observe the contents of this manual.**

## 2 Safety and prevention

### 2.1 Introduction

The burners have been designed and built in compliance with current regulations and directives, applying the known technical rules of safety and envisaging all the potential danger situations. It is necessary, however, to bear in mind that the imprudent and clumsy use of the equipment may lead to situations of death risk for the user or third parties, as well as the damaging of the burner or other items. Inattention, thoughtlessness and excessive confidence often cause accidents; the same applies to tiredness and sleepiness.

It is a good idea to remember the following:

- The burner must only be used as expressly described. Any other use should be considered improper and therefore dangerous.

In particular:

it can be applied to boilers operating with water, steam, diathermic oil, and to other uses expressly foreseen by the manufacturer;

the type and pressure of the fuel, the voltage and frequency of the electrical power supply, the minimum and maximum deliveries for which the burner has been regulated, the pressurisation of the combustion chamber, the dimensions of the combustion chamber and the ambient temperature must all be within the values indicated in the instruction manual.

- Modification of the burner to alter its performance and destinations is not allowed.
- The burner must be used in exemplary technical safety conditions. Any disturbances that could compromise safety must be quickly eliminated.
- Opening or tampering with the burner components is not allowed, apart from the parts requiring maintenance.
- Only those parts envisaged by the manufacturer can be replaced.



The manufacturer guarantees safety and proper functioning only if all burner components are intact and positioned correctly.

### 2.2 Personnel training

The user is the person, body or company that has acquired the machine and intends to use it for the specific purpose. He is responsible for the machine and for the training of the people working around it.

The user:

- undertakes to entrust the machine exclusively to suitably trained and qualified personnel;
- undertakes to inform his personnel in a suitable way about the application and observance of the safety instructions. With that aim, he undertakes to ensure that everyone knows the use and safety instructions for his own duties.
- Personnel must observe all the danger and caution indications shown on the machine.
- Personnel must not carry out, on their own initiative, operations or interventions that are not within their province.
- Personnel must inform their superiors of every problem or dangerous situation that may arise.
- The assembly of parts of other makes, or any modifications, can alter the characteristics of the machine and hence compromise operating safety. The manufacturer therefore declines any and every responsibility for any damage that may be caused by the use of non-original parts.

In addition:



- must take all the measures necessary to prevent unauthorised people gaining access to the machine;
- the user must inform the manufacturer if faults or malfunctioning of the accident prevention systems are noticed, along with any presumed danger situation;
- personnel must always use the personal protective equipment envisaged by legislation and follow the indications given in this manual.

**3 Technical description of the burner**

**3.1 Burner designation**

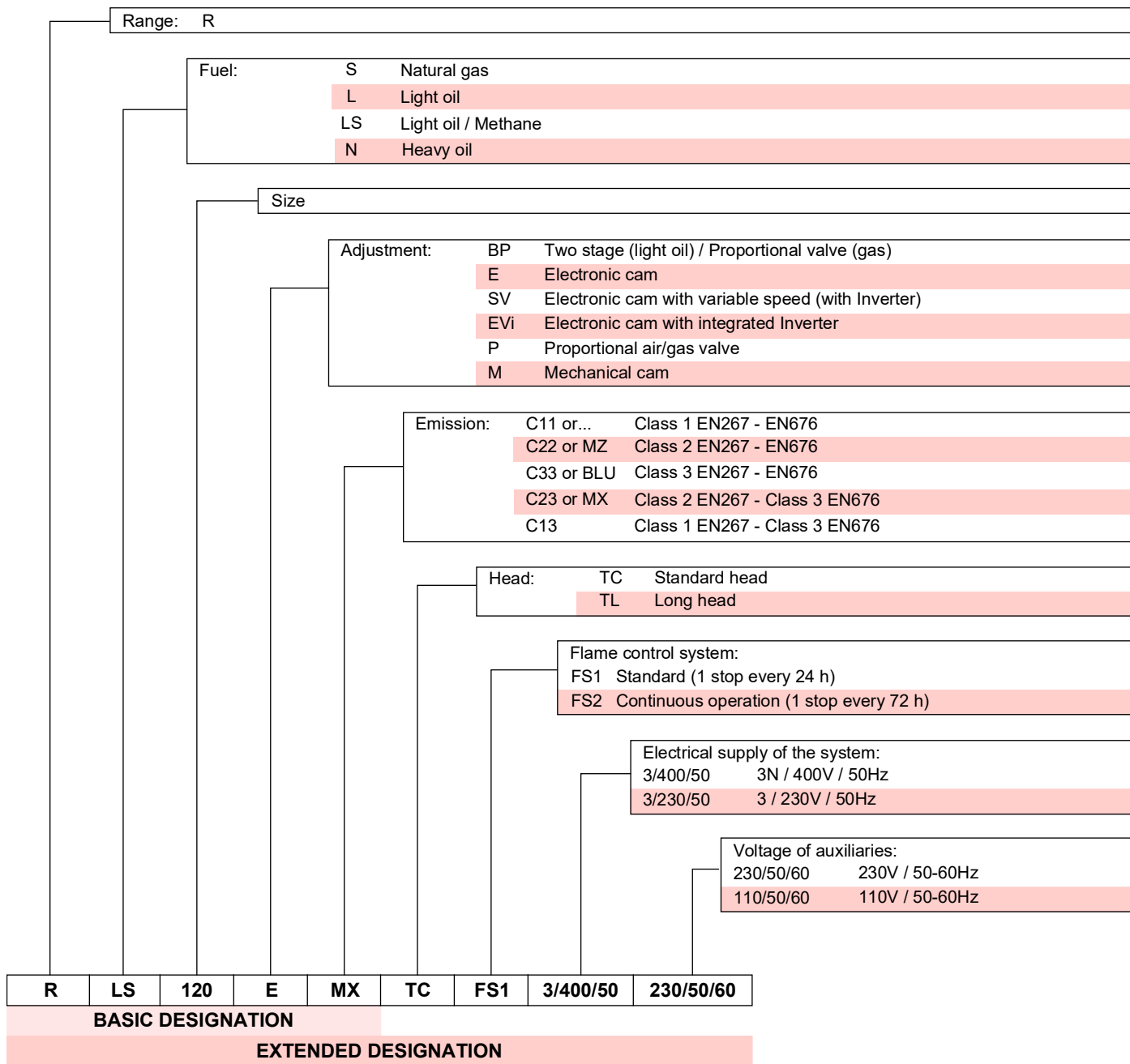

**3.2 Models available**

Designation	TC	Voltage	Start-up	Code
RLS 68/E MX FS1	TC	3/230-400/50	Direct	20073915
RLS 120/E MX FS1	TC	3/230-400/50	Direct	20073918

Tab. A

**3.3 Burner categories - Countries of destination**

Gas category	Country of destination
I2H	AT, BG, CH, CZ, DK, EE, ES, FI, GB, GR, HU, IE, IS, IT, LT, LV, NO, PT, RO, SE, SI, SK, TR
I2E(R)	BE
I2E	LU, PL
I2ELL	DE
I2EK	NL
I2Er	FR

**Tab. B**

**3.4 Technical data**

Model		RLS 68/E MX FS1		RLS 120/E MX FS1	
Power <sup>(1)</sup>	min - max	kW	195/350 - 871	290/595 - 1224	
Delivery <sup>(1)</sup>		kg/h	16/29 - 73	24/50 - 95	
Fuels		Light oil, max. viscosity at 20 °C: 6 mm <sup>2</sup> /s (1.5°E - 6 cSt) Natural gas: G20 (methane gas) - G25			
Operation		- Intermittent (min. 1 stop in 24 hours) - Oil / Gas: Progressive two-stage or modulating by kit (See ACCESSORIES)			
Nozzles		number	1		
Standard applications		Boilers: water, steam, diathermic oil			
Ambient temperature		°C	0 - 40		
Combustion air temperature		°C max	60		
Pump	output (at 20 bar)	kg/h	195		
	pressure range	bar	10 - 21		
	fuel temperature	°C max	90		
Noise levels <sup>(2)</sup>	Sound pressure	dB(A)	76	79	
	Sound power		87	90	
Weight		kg	70	76	
CE		CE-0476DQ3601			

**Tab. C**

- (1) Reference conditions: Ambient temperature 20°C - Gas temperature 15°C - Barometric pressure 1,013 mbar - Altitude 0 m a.s.l.  
 (2) Sound pressure measured in manufacturer's combustion laboratory, with burner operating on test boiler and at maximum output. The sound power is measured with the "Free Field" method, as per EN 15036, and according to an accurate "Accuracy: Category 3" measurement, as described in EN ISO 3746.

**3.5 Electrical data**

Model		RLS 68/E MX FS1		RLS 120/E MX FS1	
Main electrical supply		3~ 230/400V +/-10% 50Hz			
Auxiliary circuit electrical supply		1N~ 230V 50Hz			
Max. Absorbed electric power main electrical supply		W			
- light oil	1880				2,588
- gas	1,800			2,588	
Max. Absorbed electric power auxiliary circuit electrical supply		W			
- light oil	1300				1300
- gas	500			500	
Protection level		IP 44			

**Tab. D**

**3.6 Maximum dimensions**

The maximum dimensions of the burner are given in Fig. 1.

The dimensions of the open burner are indicated by position I.

Bear in mind that inspection of the combustion head requires the burner to be opened and the rear part drawn back on the slide bars.

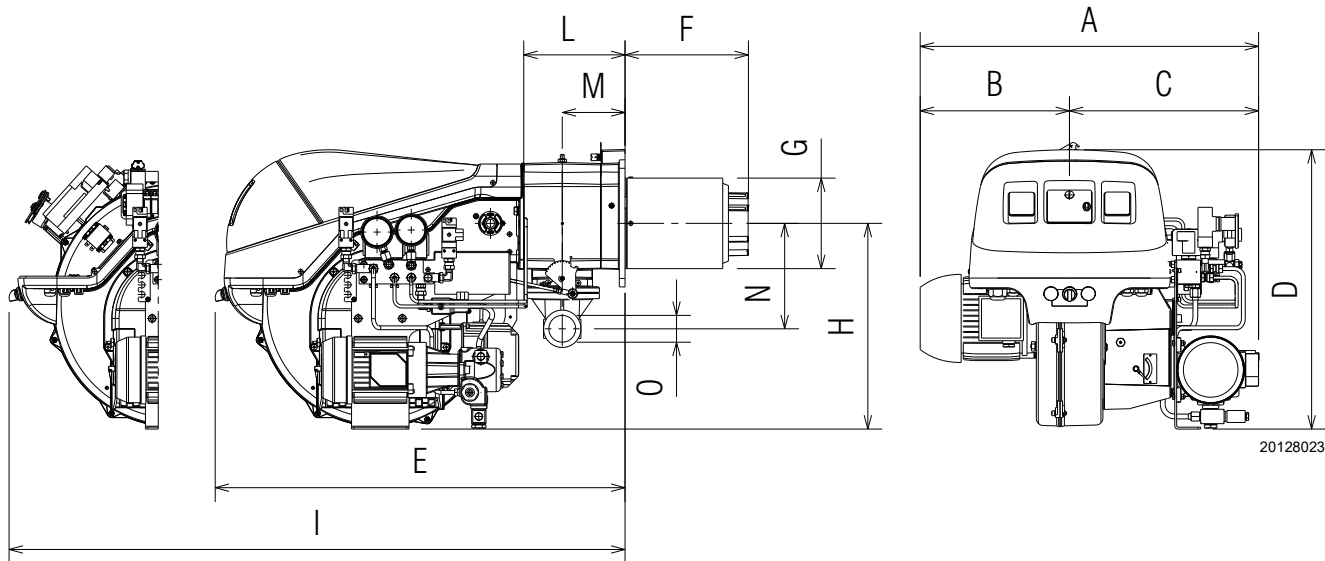

**Fig. 1**

mm	A	B	C	D	E	F*	G	H	I*	L	M	N	O
RLS 68/E	705	310	395	585	860	260	189	430	1325	214	134	221	2"
RLS 120/E	730	335	395	585	860	260	189	430	1325	214	134	221	2"

**Tab. E**

3.7 Firing rates

The **maximum output** should be chosen within area A)(Fig. 2) of the diagram.

The **minimum output** must not be lower than the minimum limit of the diagram.



The firing rate was obtained with an ambient temperature of 20°C and a barometric pressure of 1013 mbar (approx. 0m above sea level), with the combustion head adjusted as shown on page 24.



For the operation inside area B)(Fig. 2) remove the gas nozzle as indicated in paragraph “**Removing the nozzles**” on page 23.

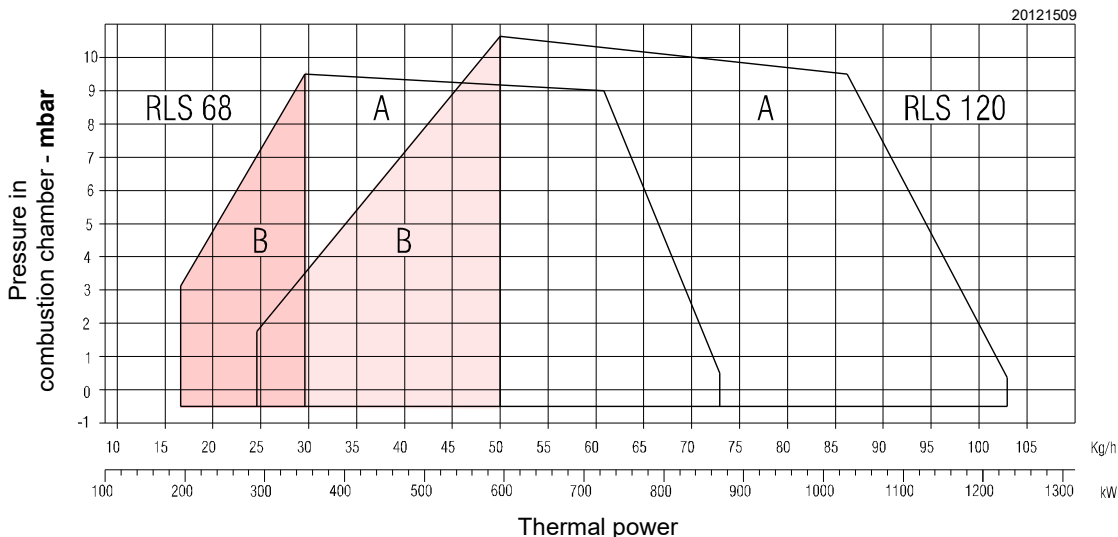

Fig. 2

3.8 Test boiler

The firing rates were established in special test boilers, according to EN 676 regulations.

In Fig. 3 you can see the diameter and length of the test combustion chamber.

**Example:**  
output 756 kW (650 Mcal/h): diameter 60cm, length 2m.

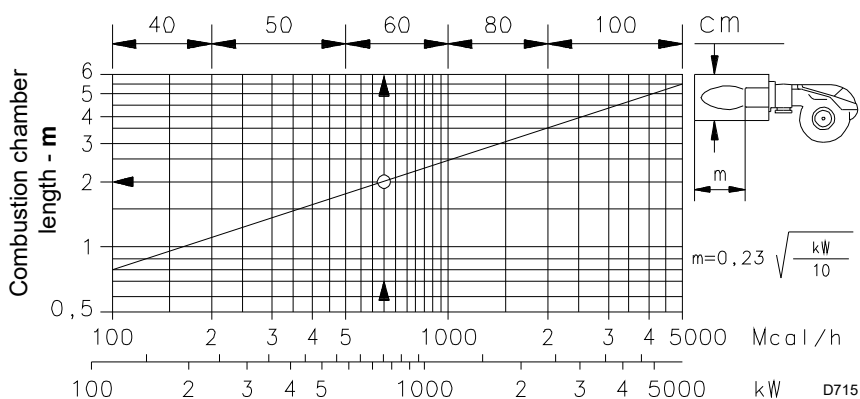

Fig. 3

**3.9 Commercial boilers**

The burner is suitable for operating on both flame inversion boilers (\*), as well as on boilers with a combustion chamber with run-off from the bottom (three flue passes) on which the best results for low NO<sub>x</sub> emissions are obtained.

The boiler front door maximum thickness must not exceed 200 mm (Fig. 4).

The coupling is ensured when the boiler is EC type-approved; for boilers or ovens with combustion chambers of very different dimensions compared to those shown in the diagram of Fig. 3 preliminary checks are recommended.

(\*) For flame inversion boilers, a kit is available to reduce the CO, if necessary.

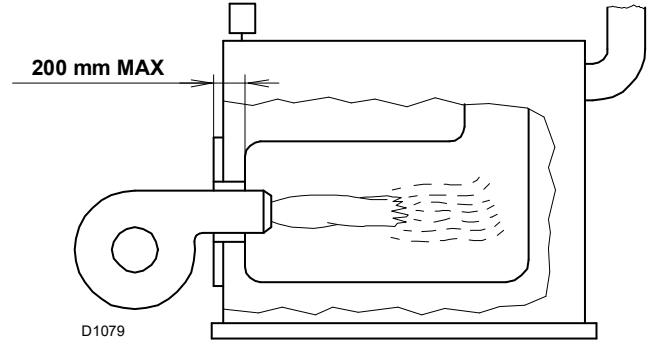

**Fig. 4**

**3.10 Burner equipment**

Flange for gas train . . . . .	No. 1
Slide bar extensions . . . . .	No. 2
Gasket for flange . . . . .	No. 1
M10x35 screws to fix the gas flange . . . . .	No. 4
Thermal insulation screen . . . . .	No. 1
Screws M12x35 to fix the burner flange to the boiler . . . . .	No. 4
Flexible hoses . . . . .	No. 2
Fitting for flexible hoses . . . . .	No. 2
Gaskets . . . . .	No. 2
Spare parts list . . . . .	No. 1
Instructions . . . . .	No. 1



It is recommended to tighten the screws of the gas flange with a tightening torque of **30 Nm ±10%**.

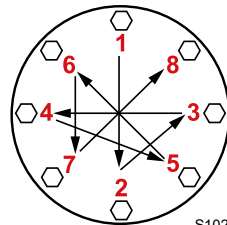

Tighten the nuts gradually (first to 30%, then to 60% up to 100%) according to the cross pattern shown in the figure.

S10230

3.11 Burner description

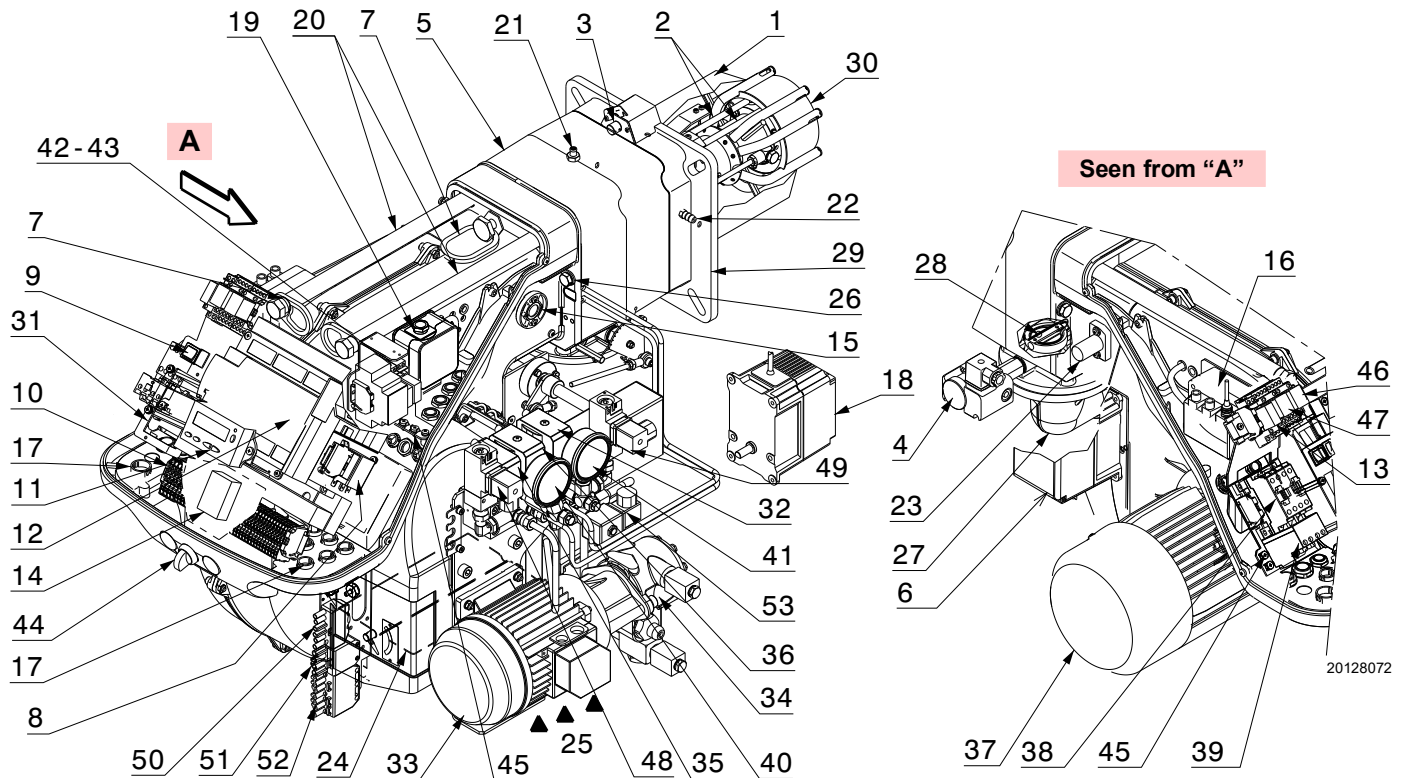

Fig. 5

- |  |  |
|--|--|
| 1 Combustion head  | 33 Pump motor                              |
| 2 Ignition electrodes  | 34 Pump                                    |
| 3 Screw for combustion head adjustment                                       | 35 Safety valve                            |
| 4 Maximum gas pressure switch  | 36 Working valve                           |
| 5 Pipe coupling  | 37 Fan motor                               |
| 6 Fuel servomotor  | 38 Contactor                               |
| 7 Lifting rings  | 39 Overload                                |
| 8 Pump motor starter   | 40 Nozzle delivery pressure gauge          |
| 9 OFF/ON selector (0-1)  | 41 Nozzle return pressure gauge            |
| 10 Terminal board for electrical wiring                                      | 42 "K1" relay                              |
| 11 Operator panel with LCD display   | 43 "K2" relay                              |
| 12 Flame control   | 44 "OIL-EXT-GAS" selector                  |
| 13 "K3" relay  | 45 Terminals for earthing                  |
| 14 Filter to protect against radio disturbance                               | 46 Relay with timer "KO"                   |
| 15 Flame inspection window   | 47 Relay with timer "KG"                   |
| 16 Ignition transformer  | 48 Minimum oil pressure switch             |
| 17 Cable grommets for electrical wiring (to be carried out by the installer) | 49 Maximum oil pressure switch             |
| 18 Air servomotor  | 50 6-pin socket                            |
| 19 Air pressure switch   | 51 4-pin socket                            |
| 20 Slide bars for opening the burner and inspecting the combustion head      | 52 7 pole socket                           |
| 21 Gas pressure test point and head fixing screw                             | 53 Return valve (VR1) (only for RLS 120/E) |
| 22 Air pressure test point   |  |
| 23 Flame sensor  |  |
| 24 Air damper  |  |
| 25 Fan air inlet   |  |
| 26 Screws to secure fan to pipe coupling                                     |  |
| 27 Gas input pipe  |  |
| 28 Gas butterfly valve   |  |
| 29 Boiler fixing flange  |  |
| 30 Flame stability disc  |  |
| 31 Bracket for application of output power regulator RWF50 (option)          |  |
| 32 Return valve (VR)   |  |

**3.12 Flame control (LMV 26...)**

**Important notes**



**WARNING**

To avoid accidents, material and/or environmental damage, observe the following instructions!

The flame control is a safety device! Avoid opening or modifying it, or forcing its operation. Riello S.p.A. cannot assume any responsibility for damage resulting from unauthorised interventions!



**Risk of explosion!**

An incorrect configuration can provoke fuel overcharging, with the consequential risk of explosion! The operators must be aware that the incorrect setting of the visualisation and operation flame control, and of the positions of the fuel and/or air actuators, can cause dangerous conditions during burner operation.

The flame control is a system to check the burners, based on a microprocessor and equipped with components to adjust and supervise medium and large capacity forced draught burners.

The flame control contains the following components:

- burner management system with valve leak detection control device;
- electronic device to check the fuel/air ratio with a maximum of 2 actuators;
- Modbus interface.



**WARNING**

For the safety and reliability of the flame control, comply with the following instructions:

- All interventions (assembly and installation operations, assistance, etc.) must be carried out by qualified personnel.
- Before carrying out any checks on the wiring, fully isolate the system from the electric mains (omnipolar separation). Check the system is not powered and cannot be accidentally reconnected. Failure to do this will lead to the risk of electrocution.
- Protection against electrocution from the flame control and all connected electric components is obtained with the correct assembly.
- After every intervention (assembly and installation operations, assistance, etc.), ensure the wiring is in order and that the parameters are correctly set, then perform the safety checks.
- Falls and collisions can negatively affect the safety functions. In this case, the flame control must not be operated, even if it displays no evident damage.
- During the programming of the air-fuel ratio control curves, the technician should constantly observe the quality of the combustion process (for example using a gas analyser) and, in the event of inadequate combustion values or dangerous conditions, should take appropriate action, for example shutting down the system manually.
- The plugs of the connection cables or other accessories can be disconnected when the system has been switched off.

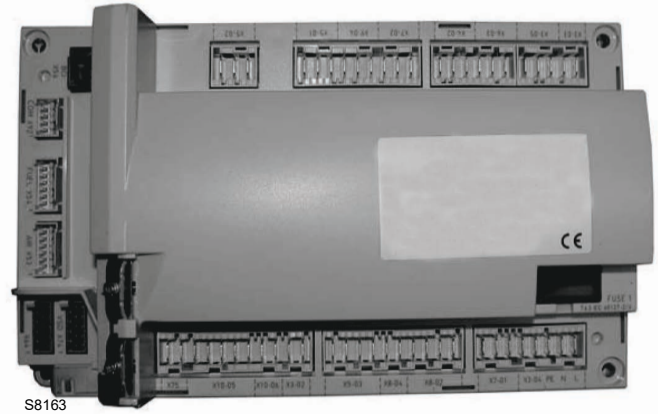

**Fig. 6**

- The connections to the actuators do not provide a secure separation from the mains voltage. Before connecting or changing the actuators the system should be off to avoid any conditions that could cause the formation of condensation or humidity. Otherwise, before switching on again, make sure that the entire flame control is perfectly dry!
- Static charges must be avoided since they can damage the flame control's electronic components when touched.
- Static charges must be avoided since they can damage the flame control's electronic components when touched.

**Technical data**

Flame control	Mains voltage	AC 230 V -15% / +10%
	Mains frequency	50 / 60 Hz ±6%
	Power absorption	< 30 W
	Safety class	I, with components in compliance with II and III, according to DIN EN 60730-1
Load on 'input' terminals	Fuse on the flame control (can be inspected)	6.3 AT
	Undervoltage	
Cable length	– Safety switch-off from operating position to mains voltage	< AC 190 V
	– Restart when mains voltage picks up	> AC 195 V
	– Main line AC 230 V	Max. 100 m (100 pF / m)
	– Control load (TL1-TL2)	Max. 20 m (100 pF/m)
	– External reset button (RS)	Max 20 m (100 pF/m)
	– Load exit (DC 0/2...10V)	Max. 10 m (100 pF/m)
Environmental conditions	– Fuel valve	Max. 3 m (100 pF/m)
	– Other lines	Max. 3 m (100 pF/m)
	<b>Storage</b>	DIN EN 60721-3-1
	– Climatic conditions	Class 1K3
	– Mechanical conditions	Class 1M2
	– Temperature range	-20 ... +60 °C
	– Humidity	< 95% RH
	<b>Transport</b>	DIN EN 60721-3-2
	– Climatic conditions	Class 2K2
	– Mechanical conditions	Class 2M2
	– Temperature range	-30 ... +60 °C
	– Humidity	< 95% RH
<b>Operation</b>	DIN EN 60721-3-3	
– Climatic conditions	Class 3K3	
– Mechanical conditions	Class 3M3	
– Temperature range	-20 ... +60 °C	
– Humidity	< 95% RH	

**Tab. F**

**WARNING**

Condensation, the formation of ice and the entry of water are prohibited!

**3.12.1 Operation sequence of the burner (gas operation)**

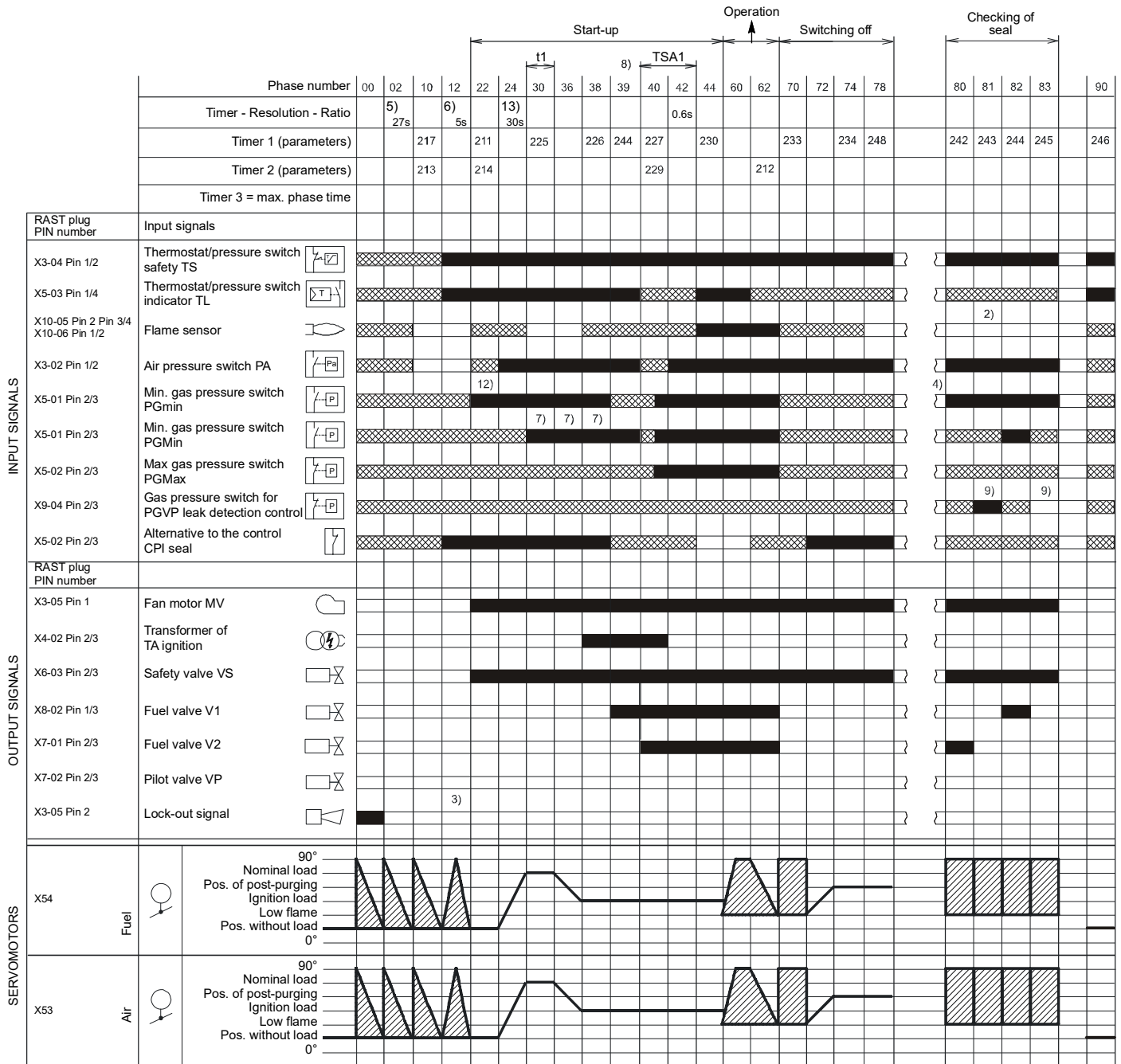

S8870

Fig. 7

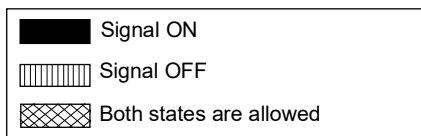

3.12.2 Operation sequence of the burner (light oil operation)

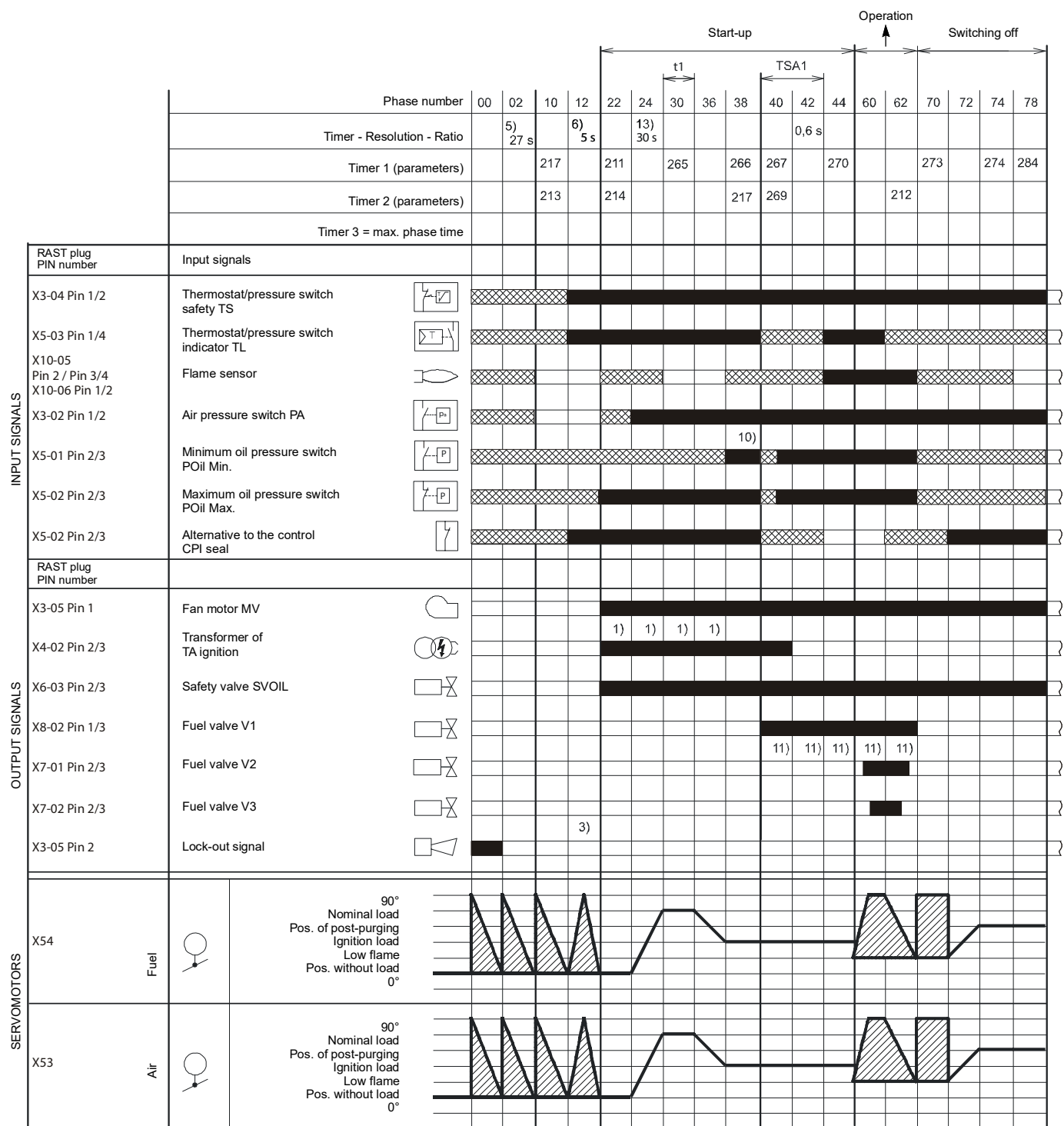

S9230

Fig. 8

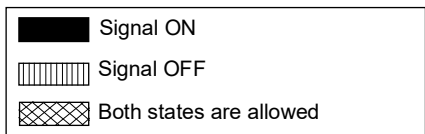

**3.12.3 List of the phases (gas operation)**

Phase	Description
Ph00	Lockout phase
Ph02	Safety phase
Ph10	Closing paused
Ph12	Standby
Ph22	Fan motor(MV) = ON Safety valve (VS) = ON
Ph24	The burner moves to the pre-purging position
Ph30	Pre-purging time
Ph36	The burner moves to the ignition position
Ph38	Ignition phase (TA) = ON
Ph39	Minimum gas pressure switch test (PGmin.)
Ph40	Fuel valve (V) = ON
Ph42	Ignition (TA) = OFF
Ph44	t44 = interval time 1
Ph60	Operation
Ph62	The burner moves to the switching off position
Ph70	t13 = post-combustion time
Ph72	The burner moves to the post-purging position
Ph74	t8 = post-purging time
Ph78	t3 = post-purging time
Ph80	Emptying time (valve leak detection)
Ph81	Atmospheric time test (valve leak control)
Ph82	Filling time (valve leak detection)
Ph83	Pressure test time (valve leak detection)
Ph90	Standby time due to lack of gas

**Tab. G**

**3.12.4 List of the phases (light oil operation)**

Phase	Description
Ph00	Lockout phase
Ph02	Safety phase
Ph10	Closing paused
Ph12	Standby
Ph22	Fan motor(MV) = ON Pump motor (MP) = ON Safety valve (SVOIL) = ON Test maximum oil pressure switch (POilmax)
Ph24	The burner moves to the pre-purging position
Ph30	Pre-purging time
Ph36	The burner moves to the ignition position
Ph38	Ignition phase (TA) = ON Test minimum oil pressure switch (POilmin)
Ph40	Fuel valve (V) = ON
Ph42	Ignition (TA) = OFF
Ph44	t44 = interval time 1
Ph60	Operation
Ph62	The burner moves to the switching off position
Ph70	t13 = post-combustion time
Ph72	The burner moves to the post-purging position
Ph74	t8 = post-purging time
Ph78	t3 = post-purging time

**Tab. H**

**3.13 Operator panel operation**

The flame control LMV 26... is connected directly to the operator panel (Fig. 9).

The buttons allow you to programme the operation and diagnostics menus.

The burner management system is shown on the LCD display (Fig. 10). To simplify the diagnostics, the display shows the operating status, type of problem, and when the problem arose.



**WARNING**

- Observe the procedures and adjustments shown below.
- All interventions (assembly and installation operations, assistance, etc.) must be carried out by qualified personnel.
- If the display and operator panel are dirty, clean them with a dry cloth.
- Protect the panel from excessive temperatures and liquids.

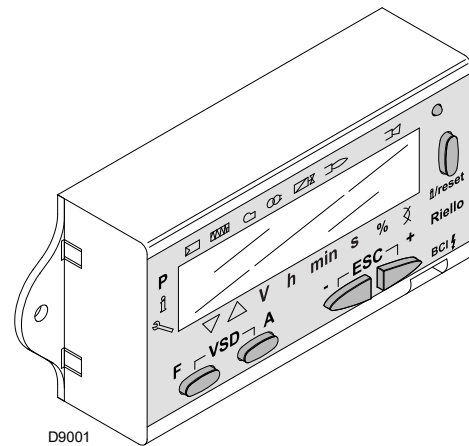

**Fig. 9**

3.13.1 Description of the symbols on the display

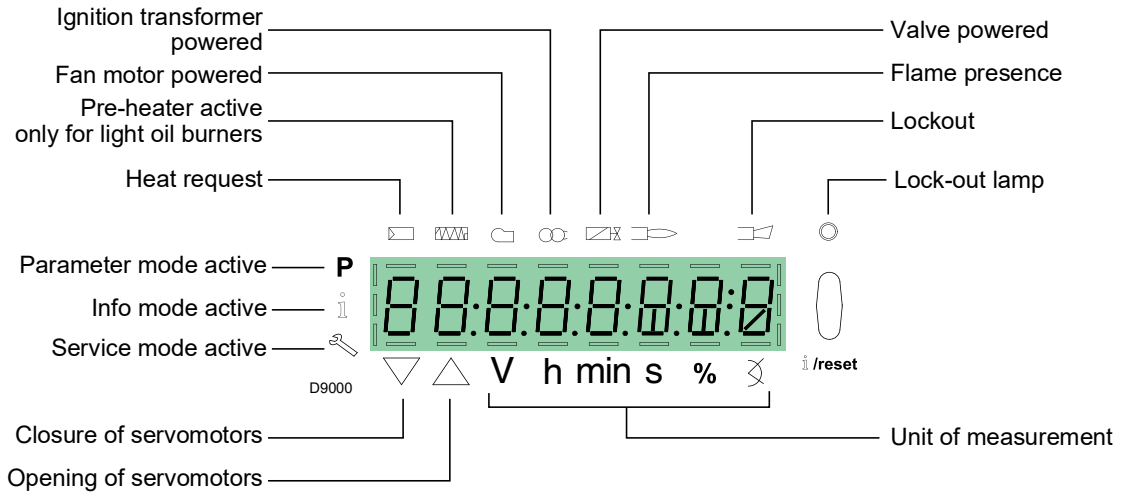

Fig. 10

The brightness of the display can be adjusted from 0 ... 100% with the parameter 126.

3.13.2 Description of the buttons

Button	Button	Function
	<b>Button F</b>	To adjust the fuel servomotor (keep  pressed and adjust the value by pressing  or )
	<b>Button A</b>	To adjust the air servomotor (keep  pressed and adjust the value by pressing  or )
	<b>Buttons A and F VSD function</b>	To change the mode setting parameter P (simultaneously press  and  plus  or )
	<b>Button Info and Enter</b>	<ul style="list-style-type: none"> <li>• <b>Enter</b> in Parameters Mode</li> <li>• <b>Reset</b> in the event of a lockout</li> <li>• Access to a lower level of the menu</li> <li>• To navigate in <b>Mode Info</b> or <b>Service</b> and permits:                             <ul style="list-style-type: none"> <li>- the selection of the parameter (flashing symbol) (press for &lt;1 s)</li> <li>- access to a lower level of the menu (press from 1...3 s)</li> <li>- access to a higher level of the menu (press from 3...8 s)</li> <li>- access to another Mode (press for &gt; 8 s)</li> </ul> </li> </ul>
	<b>Button -</b>	Lowering the value <ul style="list-style-type: none"> <li>- Access to a lower point of the modulation curve</li> <li>- Scrolling the parameter list</li> </ul>
	<b>Button +</b>	Increasing the value <ul style="list-style-type: none"> <li>- Access to a higher point of the modulation curve</li> <li>- Scrolling the parameter list</li> </ul>
	<b>Buttons - and +</b>	Quit function (ESC) (press  and  simultaneously) <ul style="list-style-type: none"> <li>- Does not confirm the value</li> <li>- Access to a higher level of the menu</li> </ul>

Tab. I

### 3.14 Servomotors

#### Introduction

The servomotors are commanded by the flame control, which constantly checks their position by means of a return signal from the optic sensor inside the servomotor.



**WARNING**

For this reason it is absolutely forbidden to remove the cover of the servomotors.

The position (in degrees) of the servomotors can be seen on the display of the operator panel.

See paragraph “**List of parameters**” on page 46, parameter 922 - index “**0**” for fuel servomotor, index “**1**” for air servomotor.

The servomotors are electrically connected to the flame control by means of RAST 2.5 type connectors.

**During the maintenance or replacement of the servomotors, take care not to invert the connectors.**

Follow the indications given in the electrical layouts or the silk-screen printing on the flame control cover.



**Fig. 11**

#### Technical data

Model	SQM33.5...
Type of motor	Stepping motor
Electrical supply	AC/DC 24V
Protection level	IP54
Firing rate	0 - 90°
Opening time 0 - 90°	5 s
Torque	3 Nm
Input power	10 W
Rotation	Clockwise/anticlockwise (can be selected from the flame control)

**Tab. J**

**4 Installation**

**4.1 Notes on safety for the installation**

After carefully cleaning all around the area where the burner will be installed, and arranging the correct lighting of the environment, proceed with the installation operations.



All the installation, maintenance and disassembly operations must be carried out with the electricity supply disconnected.



The installation of the burner must be carried out by qualified personnel, as indicated in this manual and in compliance with the standards and regulations of the laws in force.



Combustion air inside the boiler must be free from hazardous mixes (e.g.: chloride, fluoride, halogen); if present, it is highly recommended to carry out cleaning and maintenance more frequently.

**4.2 Handling**

The burner packaging includes a wooden platform, it is therefore possible to move the burner (still packaged) with a transpallet truck or fork lift truck.



The handling operations for the burner can be highly dangerous if not carried out with the greatest attention: keep any unauthorised people at a distance; check the integrity and suitability of the available means of handling. Check also that the area in which you are working is empty and that there is an adequate escape area (i.e. a free, safe area to which you can quickly move if the burner should fall). When handling, keep the load at not more than 20-25 cm from the ground.



After positioning the burner near the installation point, correctly dispose of all residual packaging, separating the various types of material.



Before proceeding with the installation operations, carefully clean all around the area where the burner will be installed.

**4.3 Preliminary checks**

**Checking the consignment**



After removing all the packaging, check the integrity of the contents. In the event of doubt, do not use the burner; contact the supplier.



The packaging elements (wooden cage or cardboard box, nails, clips, plastic bags, etc.) must not be abandoned as they are potential sources of danger and pollution; they should be collected and disposed of in the appropriate places.

		A		B	
		D		C	
		E		F	
GAS-KAASU	<input type="checkbox"/> FAM.2	G		H	
GAZ.AEPIQ	<input type="checkbox"/> FAM.3	G		H	
		I		H	
		L			
				CE	

20206732

**Fig. 12**

**Checking the characteristics of the burner**

Check the identification label of the burner, showing:

- the model (A) and type of burner (B);
- the year of manufacture, in cryptographic form (C);
- the serial number (D);
- the data for electrical supply and the protection level (E);
- the absorbed electrical power (F);
- the types of gas used and the relative supply pressures (G);
- the data of the burner's minimum and maximum output possibilities (H) (see Firing rate).

**Warning.** The output of the burner must be within the boiler's firing rate;

- the category of the appliance/countries of destination (I);
- light oil maximum viscosity (L).



A burner label that has been tampered with, removed or is missing, along with anything else that prevents the definite identification of the burner makes any installation or maintenance work difficult.

### 4.4 Operating position



- The burner is designed to operate only in positions 1, 2, 3 and 4 (Fig. 13).
- Installation 1 is preferable, as it is the only one that allows the maintenance operations as described in this manual.
- Installations 2, 3 and 4 permit operation but make maintenance and inspection of the combustion head more difficult.



- Any other position could compromise the correct operation of the appliance.
- Installation 5 is prohibited for safety reasons.

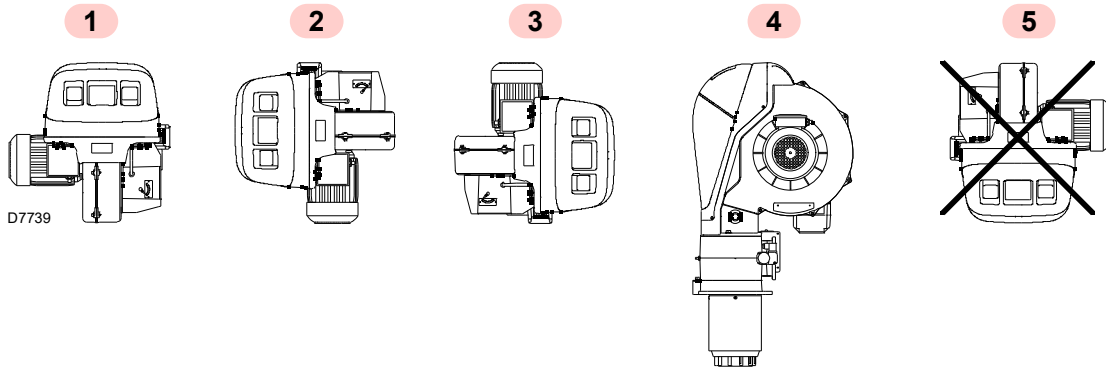

Fig. 13

### 4.5 Preparing the boiler

#### 4.5.1 Boring the boiler plate

Pierce the closing plate of the combustion chamber, as in Fig. 14. The position of the threaded holes can be marked using the thermal insulation screen supplied with the burner.

#### 4.5.2 Blast tube length

The length of the blast tube must be selected according to the indications provided by the manufacturer of the boiler, and in any case it must be greater than the thickness of the boiler door complete with its fettling.

The available lengths L are those indicated in the table below.

Blast tube (mm)	Short	Long
RLS 68/E MX	260	-
RLS 120/E MX	260	-

Tab. K

For boilers with a front flue gas passes 13)(Fig. 16) or flame inversion chamber, a protection device in refractory material 11) must be inserted between the boiler fettling 12) and the blast tube 10).

This protective fettling must not compromise the extraction of the blast tube.

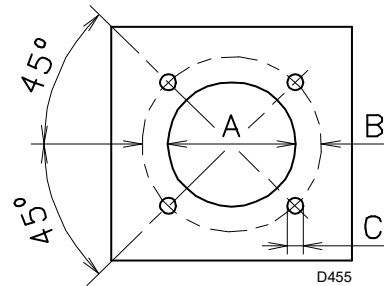

Fig. 14

mm	A	B	C
RLS 68/E MX	195	275-325	M12
RLS 120/E MX	195	275-325	M12

Tab. L

**4.6 Securing the burner to the boiler**

Before fixing the burner to the boiler, check from the opening of the blast tube if the electrodes are positioned correctly as in Fig. 25.

If in the previous check the position was not correct, remove the screw 1)(Fig. 15) extract the inner part 2) of the head, and adjust them.



Provide an adequate lifting system.

Separate the combustion head from the rest of the burner, (Fig. 16). To do this, proceed as follows:

- loosen the 4 screws 3) and remove the hood 1);
- disconnect the light oil pipes unscrewing the two unions 16);
- remove screws 2) and lifting rings from the two slide bars 5);
- disconnect the tie-rod 14) from the sector 15);
- disconnect the socket from the maximum gas pressure switch;
- remove the two screws 4);
- pull back the burner on the slide bars 5) by about 100 mm;
- disconnect the cables, then completely unthread the burner from the slide bars.

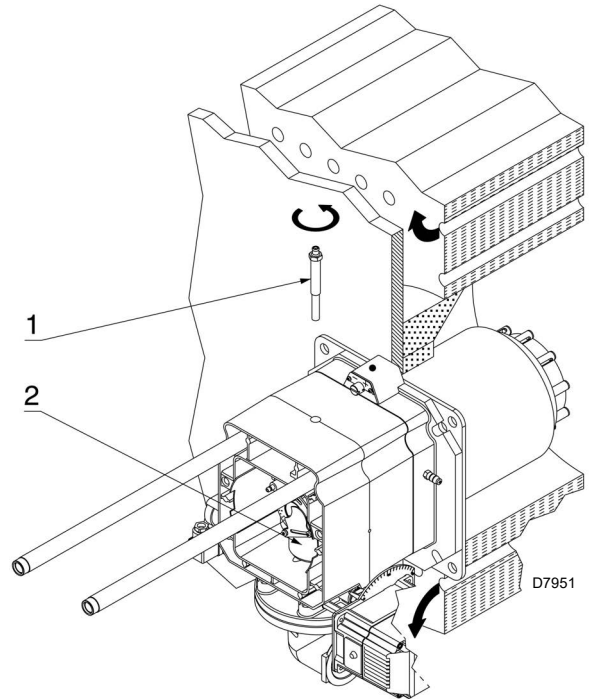

Fig. 15

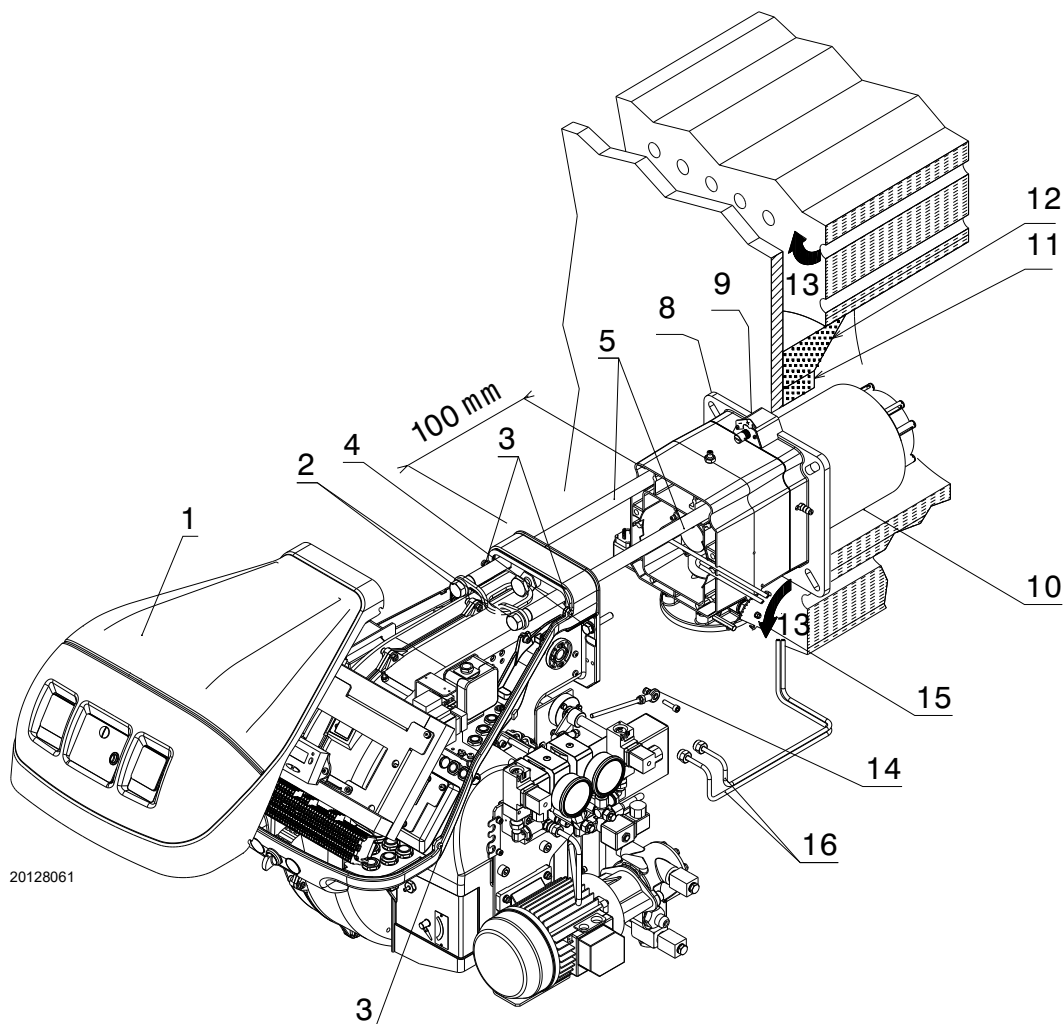

Fig. 16

**4.7 Nozzle**

The burner complies with the emission requirements of the EN 267 standard. In order to guarantee that emissions do not vary, recommended and/or alternative nozzles specified by Riello in the Instruction and warning booklet should be used.



It is advisable to replace the nozzle once a year during periodical maintenance.



The use of nozzles other than those specified by Riello S.p.A. and inadequate regular maintenance may result into emission limits non-conforming to the values set forth by the regulations in force, and in extremely serious cases, into potential hazards to people and objects.

The manufacturing company shall not be liable for any such damage arising from non-observance of the requirements contained in this manual.

**4.7.1 Recommended nozzles**

- Bergonzo type A3 - angle 45° (Fig. 17)
- Bergonzo type A4 - 45° angle

If you want a delivery somewhere between the two values shown in the diagram (Fig. 17), select a nozzle with a higher flow rate.

The reduction in the flow rate is obtained with the pressure variator.

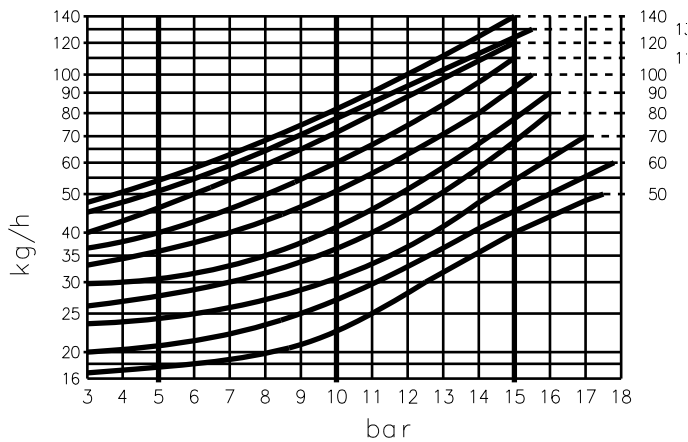

**Fig. 17**

**4.7.2 Nozzle installation**

- Remove the screw 1)(Fig. 18) and the internal part 2);
- remove the nozzle 1)(Fig. 19) using a wheel spanner;
- install the nozzle 1)(Fig. 19);
- fix it with the spanner through the central hole of the flame stability disk or loosen the screws 1)(Fig. 20);
- remove the disk 2) and replace the nozzle with the spanner 3).



- Do not use any sealing products such as: gaskets, sealing compound, or tape.
- Be careful to avoid damaging the nozzle sealing seat.
- The nozzle must be screwed into place tightly but not to the maximum torque value provided by the wrench.

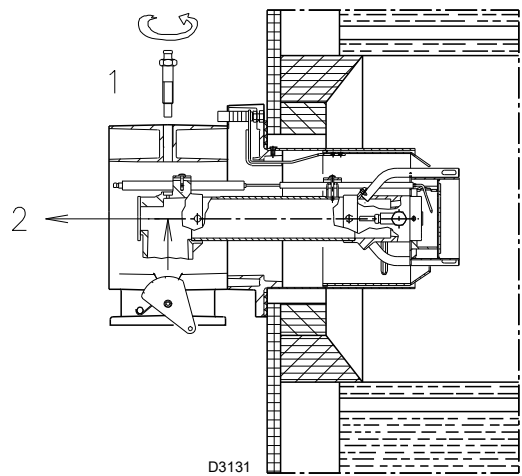

**Fig. 18**

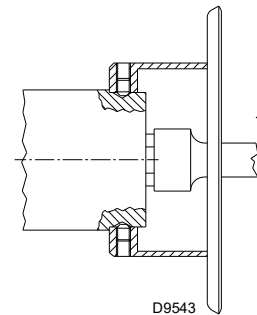

**Fig. 19**

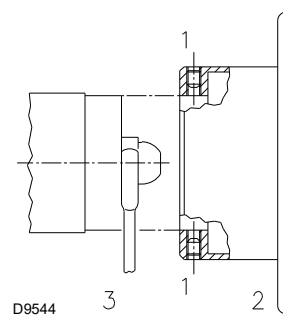

**Fig. 20**

### 4.7.3 Removing the nozzles

Necessary for the operation within area B) of the "Firing rates" on page 9.

- extract the internal part of the combustion head as described in paragraph "Nozzle installation" on page 22;

- unscrew screws 1) and nuts 2);
- extract the restrictor 3);
- unscrew the nozzles 4) at the front of the head;
- replace the restrictor 3).

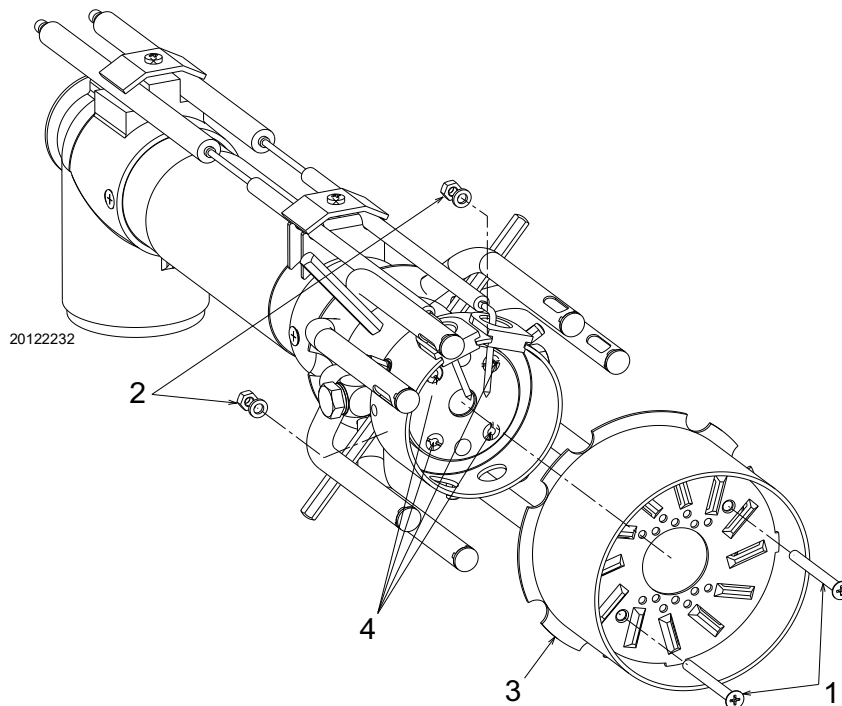

Fig. 21

### 4.8 Pressure variator

The value of the pressure on the return line of the nozzle is shown on the pressure gauge 1)(Fig. 22).

The pressure and the flow output of the nozzle are at their maximum when the servomotor is at the maximum position.

For a correct calibration, the eccentric 6) must operate on the entire range of travel of the servomotor: a pressure variation must correspond to every variation of the servomotor.



**WARNING**

Never take the piston of the variator to the end: the stop ring 4) determines the maximum travel.

If you want to check the output delivery of the nozzle, open the burner, connect a pipe to the nozzle, simulate the ignition and proceed with the weighing of the fuel at the maximum and minimum pressures.

If at the maximum delivery of the nozzle (maximum pressure on the return line) pressure oscillations can be seen on the pressure gauge 1), slightly reduce the pressure until they disappear.

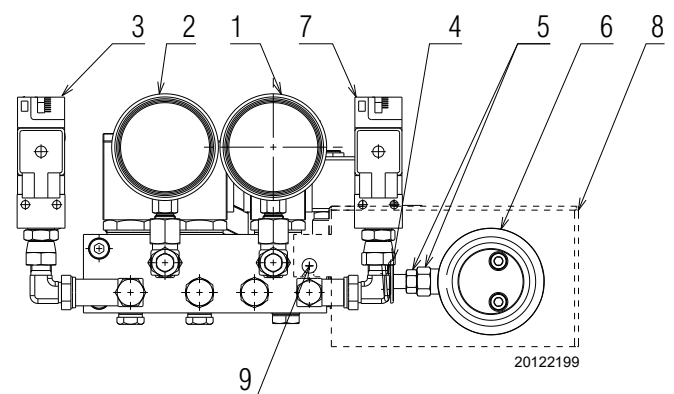

Fig. 22

Key (Fig. 22)

- 1 Nozzle return pressure gauge
- 2 Nozzle delivery pressure gauge
- 3 Minimum oil pressure switch
- 4 Piston stop ring
- 5 Piston calibration nut and lock nut
- 6 Variable eccentric
- 7 Maximum oil pressure switch
- 8 Eccentric cover 6) and nut 5)
- 9 Cover fixing screw

### 4.9 Combustion head adjustment

The adjustment of the combustion head depends only on the maximum output of the burner.

Turn the screw 5 (Fig. 23) until the notch indicated by the diagram (Fig. 24) corresponds with the front part of the flange 6).



To facilitate the adjustment, loosen the screw 1 (Fig. 18 on page 22), adjust, then block.

**Example:**

Burner maximum output = 750 kW (RLS 68/E)

The diagram (Fig. 24) shows that for this output, the adjustment of the combustion head is carried out on the notch 1, as in (Fig. 23).

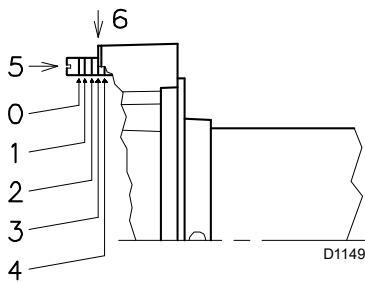

Fig. 23

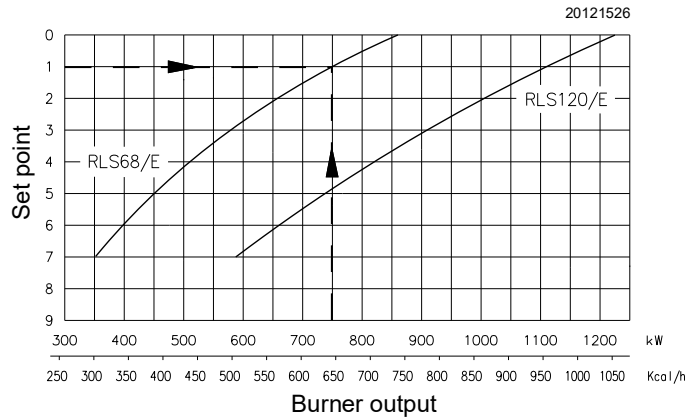

Fig. 24

### 4.10 Electrodes adjustment



Position the electrodes according to the dimensions shown in Fig. 25.

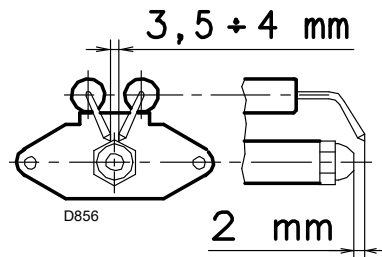

Fig. 25

### 4.11 Closing the burner

Once the combustion head adjustment is completed:

- reassemble the burner on the guides 3) at about 100 mm from the pipe coupling 4) - burner in the position shown in Fig. 16;
- insert the electrode cables and then slide the burner up to the pipe coupling;
- connect the tie-rod 14) to the sector 15);
- connect the socket of the maximum gas pressure switch;
- replace screws 2) and lifting rings on the two slide bars 3);
- connect the light oil pipes by screwing the two fittings 16);
- fix the burner to the pipe coupling with the screws 4).



When fitting the burner on the two slide bars, it is advisable to gently draw out the high voltage cable and the flame detection probe cable until they are slightly stretched.

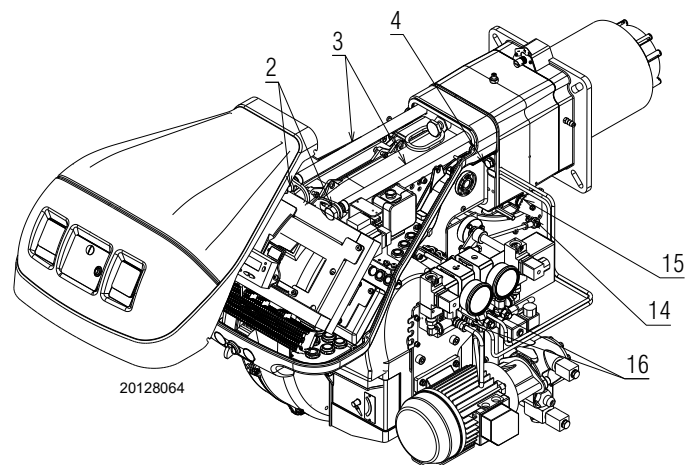

Fig. 26

**4.12 Light oil supply**



Explosion danger due to fuel leaks in the presence of a flammable source.

Precautions: avoid knocking, attrition, sparks and heat.

Make sure the fuel interception tap is closed before performing any operation on the burner.



**WARNING**

The fuel supply line must be installed by qualified personnel, in compliance with current standards and laws.

**4.12.1 Double-pipe circuit**

The burner is equipped with a self-priming pump which is capable of feeding itself within the limits listed in Tab. M.

**Tank higher than burner A (Fig. 27)**

Distance "P" must not exceed 10 meters in order to avoid straining the pump's seal; distance "V" must not exceed 4 meters in order to allow pump self-priming even when the tank is almost empty.

**Tank lower than burner B (Fig. 27)**

Pump depression values higher than 0.45 bar (35 cm Hg) must not be exceeded. Because at higher levels gas is released from the fuel, the pump starts making noise and its working life-span decreases. It is good practice to ensure that the return and suction lines enter the burner from the same height; in this way it will be less probable that the suction line fails to prime or stops priming.

**4.12.2 The loop circuit**

A loop circuit consists of a loop of piping departing from and returning to the tank with an auxiliary pump that circulates the fuel under pressure. A branch connection from the loop feeds the burner. This circuit is extremely useful whenever the burner pump does not succeed in self-priming because the tank distance and/or height difference are higher than the values listed in Tab. M.

+/- H m	L [m]		
	Ø 12 mm	Ø 14 mm	Ø 16 mm
+ 4	71	138	150
+ 3	62	122	150
+ 2	53	106	150
+ 1	44	90	150
+ 0.5	40	82	150
0	36	74	137
- 0.5	32	66	123
- 1	28	58	109
- 2	19	42	81
- 3	10	26	53
- 4	-	10	25

**Tab. M**

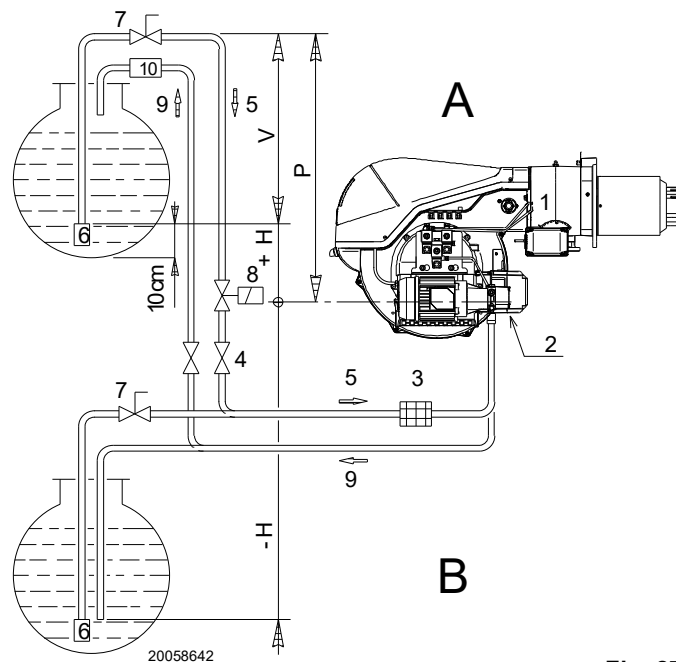

**Fig. 27**

**Key (Fig. 27)**

- H = Pump/Foot valve height difference
- L = Piping length
- Ø = Inside pipe diameter
- 1 = Burner
- 2 = Pump
- 3 = Filter
- 4 = Manual on/off valve
- 5 = Suction line
- 6 = Foot valve
- 7 = Quick closing manual valve with remote control (Italy only)
- 8 = On/off solenoid valve (Italy only).
- 9 = Return line
- 10 = Check valve (only Italy)

### 4.12.3 Hydraulic connections

The pumps are equipped with a by-pass that connects return line with suction line.

They are installed on the burner with the by-pass closed by screw 6)(Fig. 29).

It is necessary to connect both flexible hoses to the pump (Fig. 28). The pump will break down immediately if it is run with the return line closed and the by-pass screw inserted.

Remove the plugs from the suction and return connections of the pump.



**WARNING**

Follow the instructions below:

- Tighten the flexible hoses with the supplied gaskets.
- Take care that the hoses are not stretched or twisted during installation.
- Place the pipes so that they are not crushed or are in contact with hot parts of the boiler and so it is possible to open the burner.
- Finally, connect the other end of the flexible hoses to the suction and return pipes.

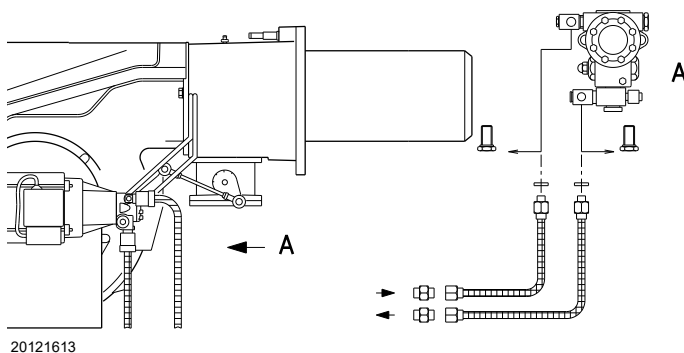

**Fig. 28**

### 4.13 Burner start-up

- The working valve closes, the motor starts.
- The pump 3)(Fig. 29) draws fuel from the tank through the pipe 1) and pushes it under pressure to the outlet.
- The piston 4) rises and the fuel returns to the tank through the piping 5) - 7). The screw 6) closes the by-pass towards the suction line and the solenoid valves 8)-9)-2)-15), de-energised, closing the path towards the nozzle.
- The damper and the pressure regulator are set to minimum output.
- Ignition electrode emits a spark.
- Solenoid valves 8) -9) -16) -17) open, the fuel passes into the pipe 10) and through the nozzle 11), exits the nozzle pulverized, and in contact with the spark, ignites: flame at low output level. The remaining fuel passes through the pipe 12) at the pressure regulated by the regulator 13), then through the pipe 7), returns into the tank.
- The starting cycle comes to an end.

Key (Fig. 29)

- 1 Pump suction
- 2 Filter
- 3 Pump
- 4 Pressure adjuster
- 5 Pressure test point
- 6 Bypass screw
- 7 Pump return line
- 8 Safety valve
- 9 Working valve
- 10 Delivery line
- 11 Nozzle
- 12 Return line
- 13 Pressure adjuster
- 14 Pressure adjustment eccentric
- 15 Maximum oil pressure switch
- 16 Return valve
- 17 Return valve
- M Pressure gauge
- V Vacuometer

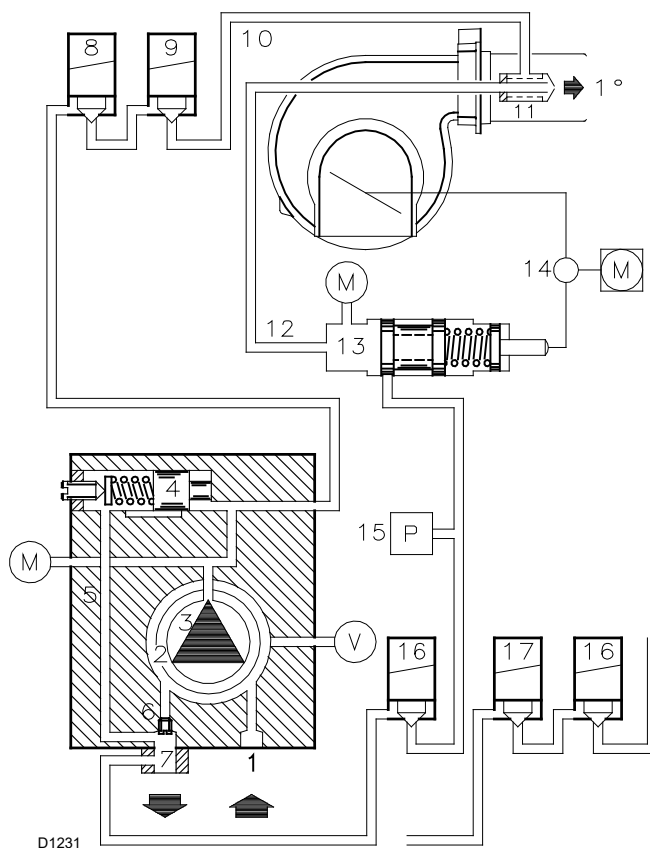

**Fig. 29**

**4.13.1 Pump**

**Technical data**

Pump	J7C
Min. delivery rate at 12 bar pressure	230 kg/h
Delivery pressure range	10 - 21 bar
Max. suction depression	0.45 bar
Viscosity range	2.8 - 200 cSt
Max. light oil temperature	90 °C
Max. suction and return pressure	1.5 bar
Pressure calibration in the factory	12 bar
Filter mesh width	0.175 mm

**Tab. N**

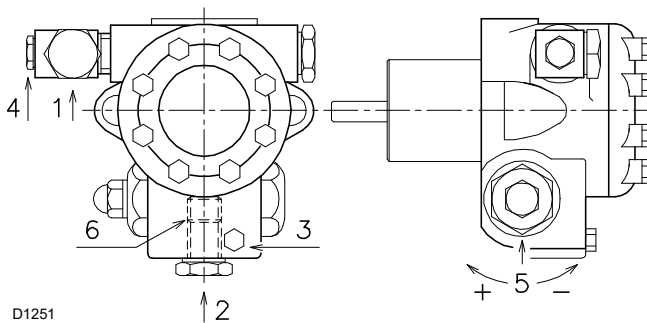

**Fig. 30**

- 1 Suction line G 1/2"
- 2 Return line G 1/2"
- 3 Gauge connection G 1/8"
- 4 Vacuometer connection G 1/8"
- 5 Pressure adjuster
- 6 By-pass screws

**4.13.2 Priming pump**



- Before starting the burner, make sure that the tank return line is not clogged.
- Obstructions in the line could cause the sealing organ located on the pump shaft to break.
- Make sure that the valves on the suction line are open and that there is fuel in the tank.

Since the pump can self-ignite, it is essential to loosen the screw 3)(Fig. 30) of the pump to vent the air from the suction line.

- Select the fuel by positioning the selector (Fig. 31) to "OIL".
- Start the burner by closing the remote control, with the selector 9)(Fig. 5 on page 11) in position "1".
- The pump can be considered to be primed when the light oil starts coming out of the screw 3)(Fig. 30).
- Stop the burner: position the selector 9)(Fig. 5 on page 11) in the "OFF" position and tighten the screws 3) of the pump.

The time required for this operation depends upon the diameter and length of the suction tubing.

If the pump fails to prime at the first starting of the burner and the burner locks out, wait approx. 15 seconds, reset the burner, and then repeat the starting operation as often as required. And so on.

After 5 or 6 starting operations allow 2 or 3 minutes for the transformer to cool.

Do not illuminate the flame sensor or the burner will lock out; the burner should lock out anyway about 10 seconds after it starts.

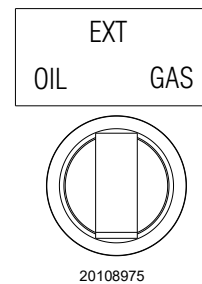

**Fig. 31**



The above-mentioned operation is possible because the pump is already full of fuel when it leaves the factory. If the pump has been drained, fill it with fuel through the opening on the vacuum meter prior to starting; otherwise, the pump will seize.

Whenever the length of the suction piping exceeds 20-30 meters, the supply line must be filled using a separate pump.

### 4.14 Gas feeding



Explosion danger due to fuel leaks in the presence of a flammable source.

Precautions: avoid knocking, attrition, sparks and heat.

Make sure the fuel interception tap is closed before performing any operation on the burner.



The fuel supply line must be installed by qualified personnel, in compliance with current standards and laws.

#### 4.14.1 Gas feeding line (Example) - Please refer to the gas train documentation for more information

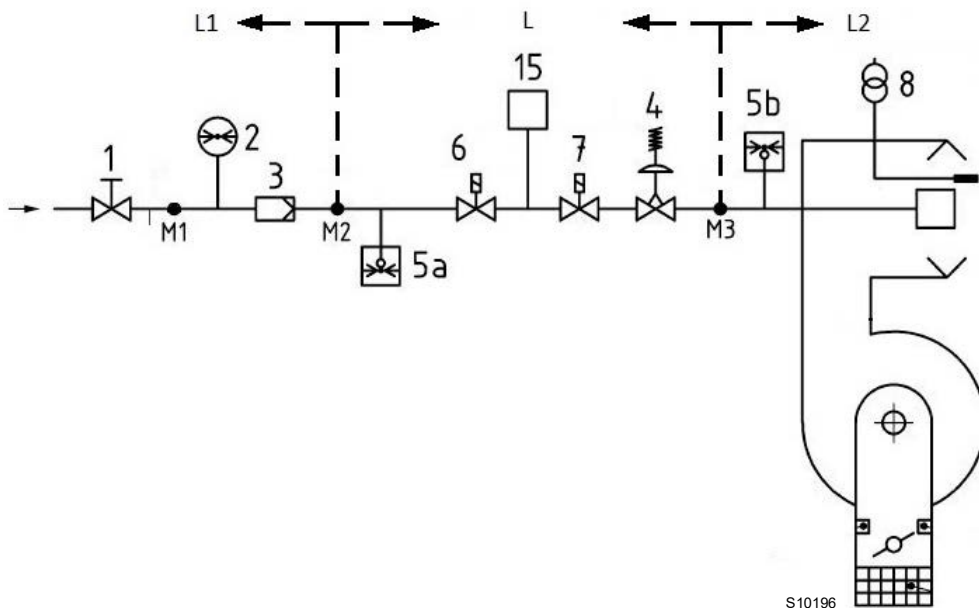

Fig. 32

Key (Fig. 32)

- 1 Manually operated shut-off valve
- 2 Pressure gauge
- 3 Filter
- 4 Governor
- 5a Low pressure protection device
- 5b Maximum gas pressure switch
- 6 1st safety shut-off device
- 7 2nd safety shut-off device
- 8 Ignition device
- 15 Valve leak detection control system
- L Gas train (supplied separately)
- L1 Responsibility of the installer
- L2 Burner
- M1 Pressure test point
- M2 Pressure test point
- M3 Pressure test point

**4.14.2 Gas pressure**

Tab. O indicates the pressure drop of the combustion head and the gas butterfly valve depending on the operating output of the burner.

The values shown the table refer to:

- natural gas G 20 NCV 10 kWh/Nm<sup>3</sup> (8.6 Mcal/Nm<sup>3</sup>)
- natural gas G 25 NCV 8.6 kWh/Nm<sup>3</sup> (7.4 Mcal/Nm<sup>3</sup>)

Column 1

Combustion head pressure drop.

Gas pressure measured at test point 1)(Fig. 33), with:

- combustion chamber at 0 mbar;
- gas butterfly valve fully opened (90°) as in Fig. 33;
- combustion head set as on page 24.

Column 2

Pressure loss at gas butterfly valve 2)(Fig. 33) with maximum opening: 90°.

To calculate the approximate output at which the burner operates:

- subtract the pressure in combustion chamber from the gas pressure measured at test point 1)(Fig. 33).
- Find, in related to the burner concerned, the pressure value closest to the result of the subtraction.
- Read off the corresponding output on the left.

**Example with G 20 natural gas - RLS 120/E MX:**

Maximum output operation

$$\begin{aligned} \text{Gas pressure at test point 1)(Fig. 33)} &= 13.4 \text{ mbar} \\ \text{Pressure in combustion chamber} &= 3.0 \text{ mbar} \\ 13.4 - 3.0 &= 10.4 \text{ mbar} \end{aligned}$$

A pressure of 10.4 mbar, (column 1, corresponds in to an output of 913 kW.

This value serves as a rough guide; the effective output must be measured at the gas meter.

To calculate the required gas pressure at test point 1)(Fig. 33), set the maximum modulating output required from the burner operation:

- find the nearest output value in for the burner in question.
- Read, on the right (column 1), the pressure at the test point 1)(Fig. 33).
- Add this value to the estimated pressure in combustion chamber.

**Example with G 20 natural gas - RLS 120/E MX:**

Operation at maximum modulating output

$$\begin{aligned} \text{Gas pressure at an output of 913 kW} &= 10.4 \text{ mbar} \\ \text{Pressure in combustion chamber} &= 3.0 \text{ mbar} \\ 10.4 + 3.0 &= 13.4 \text{ mbar} \end{aligned}$$

pressure required at test point 1)(Fig. 33).

Mod.	kW	1 Δp (mbar)		2 Δp (mbar)	
		G20	G25	G20	G25
RLS 68/E	200	1.6	2.2	0.4	0.6
	275	1.8	2.5	0.4	0.6
	349	2.3	3.2	0.5	0.7
	424	3.1	4.3	0.6	0.8
	498	4.1	5.7	0.7	1.0
	573	5.4	7.6	0.8	1.1
	647	7	9.8	0.9	1.3
	722	8.9	12.5	1	1.4
	796	11.1	15.5	1.1	1.5
	871	13.5	18.9	1.3	1.8
RLS 12/E	290	1.7	2.4	0.6	0.8
	394	2.5	3.5	0.6	0.8
	498	3.5	4.9	0.7	1.0
	601	4.8	6.7	0.8	1.1
	705	6.4	9.0	0.9	1.3
	809	8.2	11.5	1.1	1.5
	913	10.4	14.6	1.2	1.7
	1016	12.8	17.9	1.4	2.0
	1120	15.5	21.7	1.6	2.2
	1224	18.5	25.9	1.8	2.5

**Tab. O**

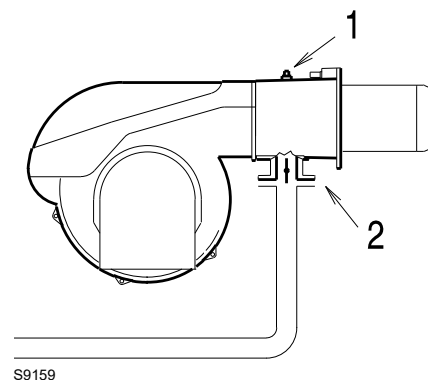

S9159

**Fig. 33**



**The data of thermal output and combustion head gas pressure are related to full open (90°) gas butterfly valve.**

**4.15 Electrical wiring**

**Notes on safety for the electrical wiring**



- The electrical wiring must be carried out with the electrical supply disconnected.
- Electrical wiring must be made in accordance with the regulations currently in force in the country of destination and by qualified personnel. Refer to the wiring diagrams.
- The manufacturer declines all responsibility for modifications or connections different from those shown in the wiring diagrams.
- Check that the electrical supply of the burner corresponds to that shown on the identification label and in this manual.
- The burner has been type-approved for intermittent use. This means they should compulsorily be stopped at least once every 24 hours to enable the flame control to perform checks of its own start-up efficiency. Normally, burner stopping is guaranteed by the boiler's thermostat/pressure switch.
- If this is not the case, a time switch should be fitted in series to IN to provide for burner stopping at least once every 24 hours. Refer to the wiring diagrams.
- The electrical safety of the device is obtained only when it is correctly connected to an efficient earthing system, made according to current standards. It is necessary to check this fundamental safety requirement. In the event of doubt, have the electrical system checked by qualified personnel. Do not use the gas tubes as an earthing system for electrical devices.
- The electrical system must be suitable for the maximum power absorption of the device, as indicated on the label and in the manual, checking in particular that the section of the cables is suitable for that level of power absorption.
- For the main power supply of the device from the electricity mains:
  - do not use adapters, multiple sockets or extensions;
  - use a multiple pole switch with at least a 3 mm gap between the contacts (overvoltage category III), as envisaged by the present safety standards.
- Do not touch the device with wet or damp body parts and/or in bare feet.
- Do not pull the electric cables.

Before carrying out any maintenance, cleaning or checking operations:



Turn off the burner's electrical supply using the main system switch.



Turn off the fuel interception tap.



Avoid condensate, ice and water leaks from forming.

If the cover is still present, remove it and proceed with the electrical wiring according to the wiring diagrams.

Use flexible cables in compliance with the EN 60 335-1 standard.

**4.15.1 Supply cables and external connections passage**

All the cables to be connected to the burner should be passed through cable grommets, as shown in Fig. 34.

Key (Fig. 34)

- 1 Three-phase power supply
- 2 6-pin plug (supplied)
- 3 4-pin plug (supplied)
- 4 7-pin plug (supplied) single-phase power supply
- 5 External selection of the fuel
- 6 Remote reset
- 7 Gas valves seal control
- 8 Signal clean contacts output

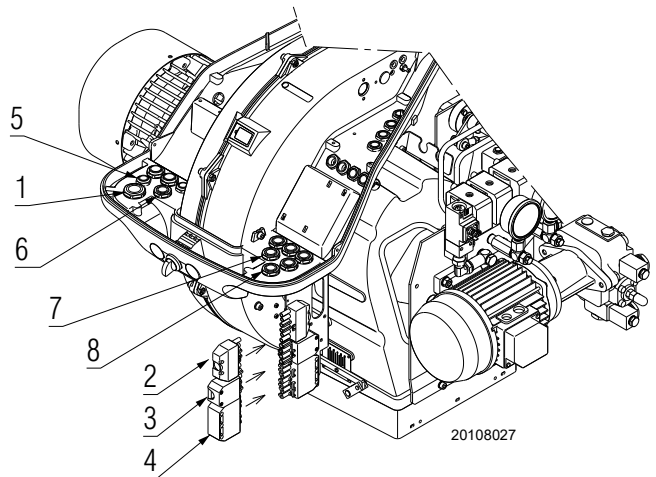

**Fig. 34**

**NOTE:**

for details of external connections, refer to the wiring diagrams included in this booklet.

To select the fuel from the outside, a switching system is provided with a contact capable of opening the TL circuit at every rotation of the selector.



After carrying out maintenance, cleaning or checking operations, reassemble the cover and all the safety and protection devices of the burner.

## 5 Start-up, calibration and operation of the burner

### 5.1 Notes on safety for the first start-up



The first start-up of the burner must be carried out by qualified personnel, as indicated in this manual and in compliance with the standards and regulations of the laws in force.



Check the correct working of the adjustment, command and safety devices.



Refer to paragraph “Safety test - with gas ball valve closed” on page 53 before the first start-up.

### 5.2 Adjustments prior to ignition (light oil)



It is recommended to adjust first the light oil burner and then the gas burner.  
Carry out the fuel change with burner off.

The optimum calibration of the burner requires an analysis of the flue gases at the boiler outlet and interventions on the following points.

#### 5.2.1 Nozzle

See information in paragraph “Nozzle” on page 22.

#### 5.2.2 Combustion head

The adjustment of the combustion head already carried out on page 24 does not require any modifications unless the burner output is changed.

#### 5.2.3 Pump pressure

In order to change the pump pressure, use the screw 5)(Fig. 30 on page 27).

#### 5.2.4 Fan damper

For the initial ignition, leave the factory setting for the 1st and 2nd stages.

### 5.3 Operations before start-up (gas)

- Ensure that the gas supply company has carried out the supply line vent operations, eliminating air or inert gases from the piping.
- Slowly open the manual valves situated upstream from the gas train.
- Adjust the minimum gas pressure switch to the start of the scale.
- Adjust the maximum gas pressure switch to the end of the scale.
- Adjust the air pressure switch to the start of the scale.
- Adjust the pressure switch for the valve leak detection control device (PVP kit), if present, according to the instructions supplied with the kit itself.
- Check the gas supply pressure by connecting a pressure gauge to the pressure test point 1)(Fig. 35) of the minimum gas pressure switch: it must be lower than the maximum allowed pressure of the gas train, as shown on the characteristics label.



**Excessive gas pressure can damage the components of the gas train and lead to a risk of explosion.**

- Bleed the air from the piping of the gas train, connecting a plastic tube to the pressure test point 1)(Fig. 35) of the minimum gas pressure switch. Take the vent tube outside the building so you can notice the smell of gas.
- Connect two lamps or testers to the two gas line solenoids to check the exact moment in which voltage is supplied. This operation is unnecessary if each of the two solenoid valves is equipped with a pilot light that signals voltage passing through.



**Before starting up the burner, it is good practice to adjust the gas train so that ignition takes place in conditions of maximum safety, i.e. with gas delivery at the minimum.**

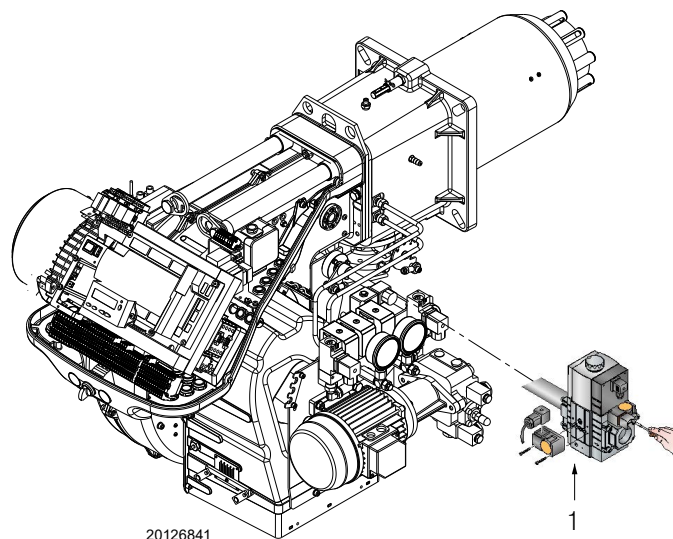

Fig. 35

**5.4 Burner start-up**

- Feed electricity to the burner via the disconnecting switch on the boiler panel.
- Close the thermostats/pressure switches.
- Put the switch to the “OIL” position for light oil operation and “GAS” for gas operation.



Make sure that the lights or testers connected to the solenoids, or the pilot lights on the solenoids themselves, indicate that no voltage is present.

If voltage is present, stop the burner **immediately** and check the electrical wiring.

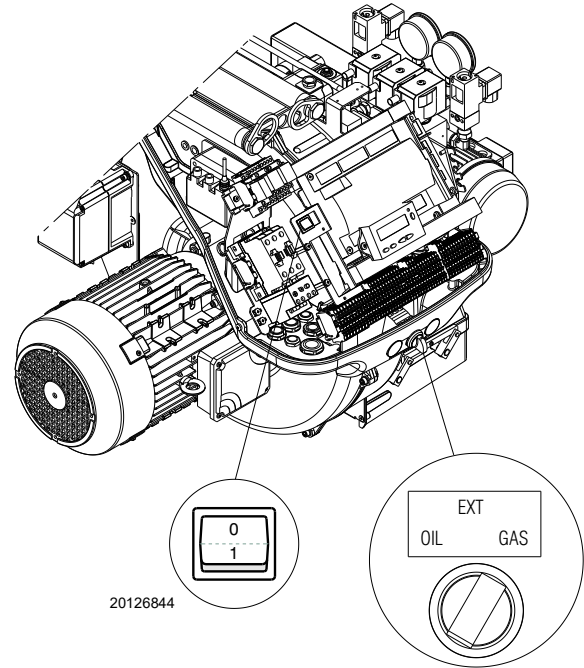

**Fig. 36**

**5.5 Change of fuel**



**The selection of the fuel must take place with the burner off.**



The burner is electrically and mechanically designed to exclude the operation with light oil and to activate the gas operation.

This modification must be made by qualified Riello personnel.

There are two change of fuel options:

- 1 with the “OIL-EXT-GAS” selector (Fig. 36);
- 2 with a remote selector connected to the main terminal board.

Positioning the selector to “EXT” activates the remote selection of the fuel.

In this position, if there is no remote selector, the display shows the priority fuel, but does not start.

In the passage between the two fuels, the following is displayed: “FUEL CHG” (Fig. 39).

The display shows when operating with:

- light oil “OFF GASO” (Fig. 37)
- gas “OFF GAS1” (Fig. 38)

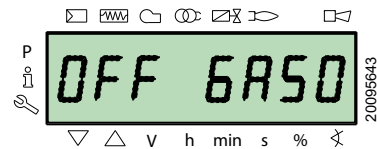

**Fig. 37**

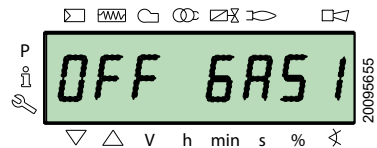

**Fig. 38**

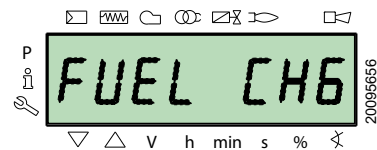

**Fig. 39**

**5.6 Burner adjustment**

**5.6.1 Gas/air delivery adjustment**

- Slightly move towards the maximum flow rate (butterfly valve fully open);
- adjust the maximum delivery required with the pressure stabiliser.
- Adjust the fuel parameters with the air servomotor and memorise the maximum combustion value;
- slowly complete the procedure, synchronising the combustion with the two servomotors and memorising the different adjustment values.



**For the start-up procedure and the adjustment of the parameters, see the specific manual of the electronic cam, supplied with the burner.**

**5.6.2 Light oil/air delivery adjustment**

- Position the selector for selecting the light oil fuel.
- During the ignition phase, slightly move towards the oil servomotor, with an approximate adjustment of max. 90°.
- Adjust the maximum pressure on the return nozzle using the "nut and blocking nut".
- Adjust the fuel parameters with the air servomotor and memorise the maximum combustion value.
- Slowly complete the procedure, synchronising the combustion with the two servomotors.
- Memorise the different adjustment values.

**5.7 Final calibration of the pressure switches**

**5.7.1 Air pressure switch**

Adjust the air pressure switch after performing all other burner adjustments with the air pressure switch set to the start of the scale (Fig. 40).

With the burner operating at MIN output, insert a combustion analyser in the stack, slowly close the suction inlet of the fan (for example, with a piece of cardboard) until the CO value does not exceed 100 ppm.

Slowly turn the appropriate knob clockwise until the burner goes into lockout.

Read the value indicated by the upward arrow on the graduated scale (Fig. 41). Turn the knob clockwise again, until the value shown on the graduated scale corresponds with the arrow pointing downwards, and so recovering the hysteresis of the pressure switch (shown by the white mark on a blue background, between the two arrows).

Now check the correct start-up of the burner.

If the burner locks out again, turn the knob anticlockwise a little bit more.

During these operations it may be useful to measure the air pressure with a pressure gauge.

The connection of the pressure gauge is shown in Fig. 41.

The standard configuration is that with the air pressure switch connected in absolute mode. Note the presence of a "T" connection, not supplied.

In certain applications in strong depression situations, the connection of the pressure switch does not allow it to change over. In this case it is necessary to connect the pressure switch in differential mode, applying a second tube between the air pressure switch and the fan suction line mouth. In this case also, the pressure gauge must be connected in differential mode, as shown in Fig. 41.



**Connecting the air pressure switch in differential mode, the burner will no longer be certified according to the EN 676 standard.**

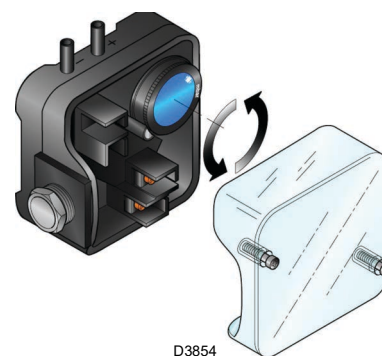

**Fig. 40**

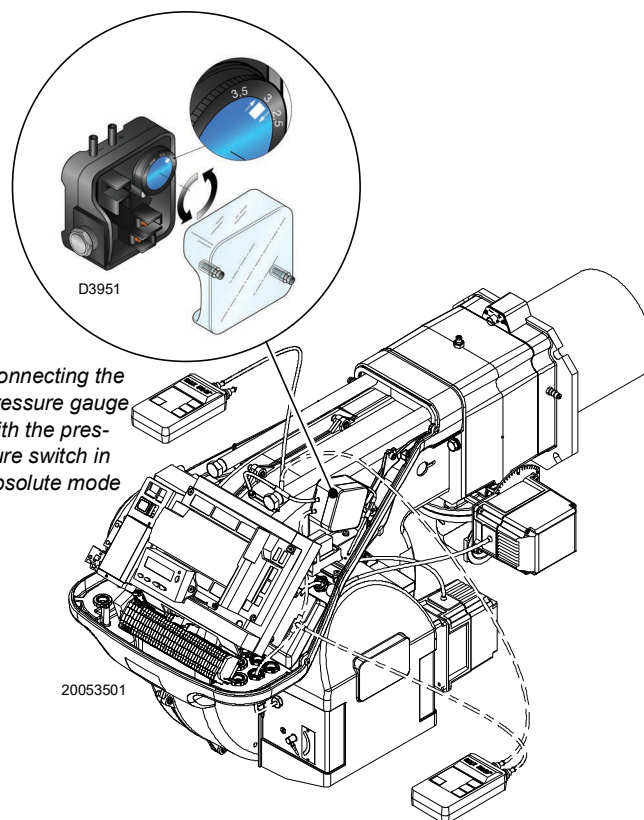

*Connecting the pressure gauge with the pressure switch in absolute mode*

*Connecting the pressure gauge with the pressure switch in differential mode*

**Fig. 41**

### 5.7.2 Maximum gas pressure switch

Adjust the maximum gas pressure switch (Fig. 42) after making all other burner adjustments with the maximum gas pressure switch set to the end of the scale.

To calibrate the maximum gas pressure switch, open the tap and then connect a pressure gauge to its pressure test point.

The maximum gas pressure switch must be regulated to a value no higher than 30% of the measurement read on the gauge when the burner is working at maximum output.

After making the adjustment, remove the pressure gauge and close the tap.

### 5.7.3 Minimum gas pressure switch

The purpose of the minimum gas pressure switch is to prevent the burner from operating in an unsuitable way due to too low gas pressure.

Adjust the minimum gas pressure switch (Fig. 43) after having adjusted the burner, the gas valves and the gas train stabiliser. With the burner operating at maximum output:

- install a pressure gauge downstream of the gas train stabiliser (for example at the gas pressure test point on the burner combustion head);
- choke slowly the manual gas cock until the pressure gauge detects a decrease in the pressure read of about 0.1 kPa (1 mbar). In this phase, verify the CO value which must always be less than 100 mg/kWh (93 ppm).
- Increase the adjustment of the gas pressure switch until it intervenes, causing the burner shutdown;
- remove the pressure gauge and close the cock of the gas pressure test point used for the measurement;
- open completely the manual gas cock.



1 kPa = 10 mbar

### 5.7.4 PVP pressure switch kit

Adjust the pressure switch for the leak detection control (PVP kit) (Fig. 44) according to the instructions supplied with the kit.

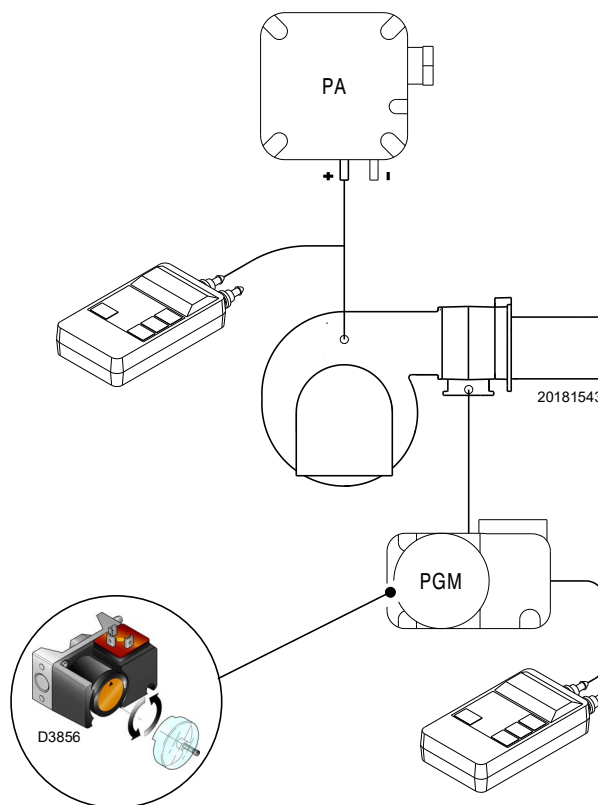

Fig. 42

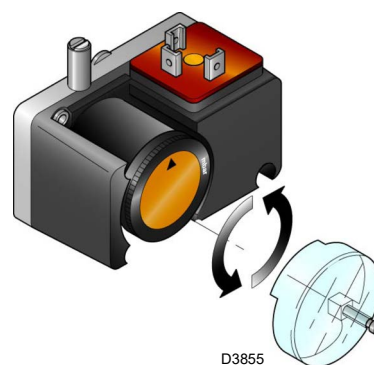

Fig. 43

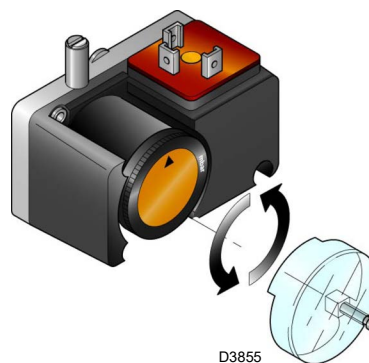

Fig. 44

### 5.7.5 Minimum oil pressure switch

The minimum oil pressure switch (Fig. 45) is calibrated in the factory at 18 bar. If the oil pressure falls below this value in the delivery line, the pressure switch stops the burner.

The burner restarts automatically if the pressure goes above 18 bar after the burner starts.

### 5.7.6 Maximum oil pressure switch

The maximum oil pressure switch (Fig. 46) is calibrated in the factory at 3 bar. If the oil pressure goes above this value in the return line, the pressure switch stops the burner.

The burner restarts automatically if the pressure drops below 3 bar, after the burner has stopped.

If a loop circuit with pressure "Px" feeds the burner, the pressure switch has to be adjusted to  $P_x + 3$  bar.

For the regulation see Fig. 46.

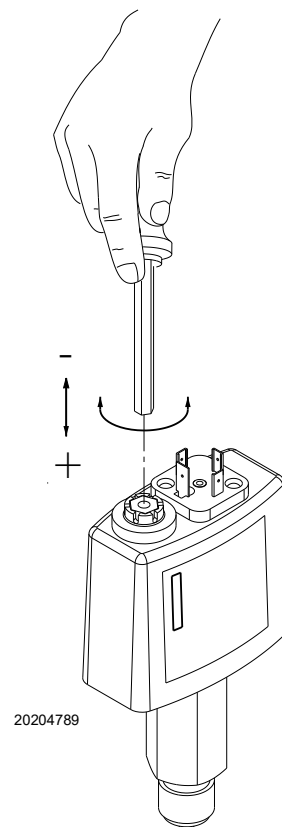

Fig. 45

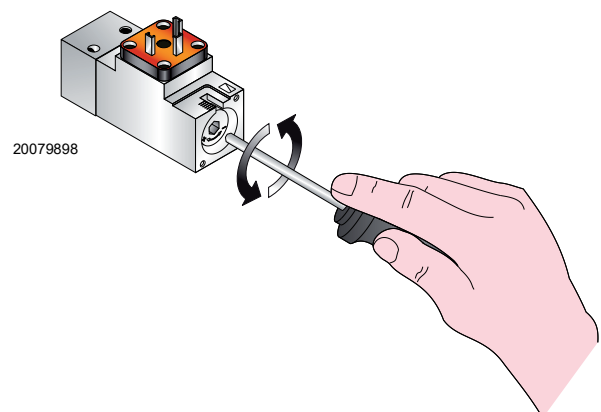

Fig. 46

**5.8 Visualisation and programming mode**

**5.8.1 Normal mode**

The Normal mode is the standard operation mode visualised on the operator panel display. It is the main level of the menu.

- Visualises the operation conditions and allows you to modify the operation point of the burner manually.
- It does not require any use of the keys of the Operator Panel.
- It allows access to the other visualisation and programming modes.

From Normal mode you can access other levels:

- Info mode (**InFo**)
- Service mode (**SEr**)
- Parameter mode (**PArA**)

Some examples in the standard conditions are given below.

**5.8.1.1 Burner in stand-by display**

The burner is in the heat request waiting mode, or the selector "OFF-ON" (Fig. 5 on page 11) is set to "OFF".

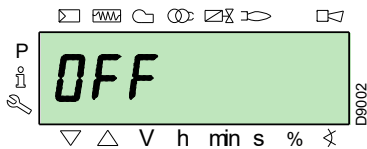

**5.8.1.2 Display during starting / stopping**

The display visualises the various phases of the start-up, ignition and switch-off of the burner.

In the example, the display indicates that the burner is in **Phase 30** (see diagram Fig. 47) and there are 12 seconds until the next phase.

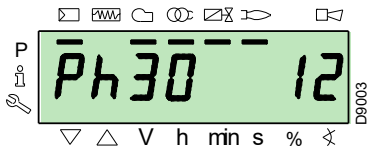

**5.8.1.3 Display of the work position**

The burner is working in the requested load position (in the example alongside, **78.4%**).

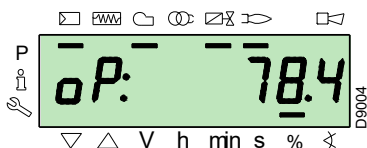

**5.8.1.4 Error state message, display of the errors and information**

The display visualises alternately the error code (in the example **c: 12**) and the relative diagnostic (in the example **d: 0**).

The system goes into safety mode and the message shown in the next figure appears.

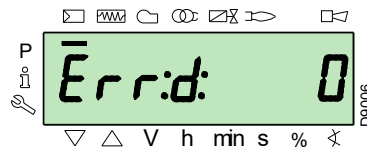
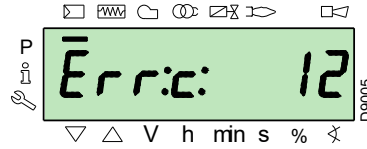

The burner goes into lockout.

The display visualises alternately the lockout code (in the example alongside **c: 4**) and the relative diagnostic (in the example **d: 3**). The red lockout lamp is on.

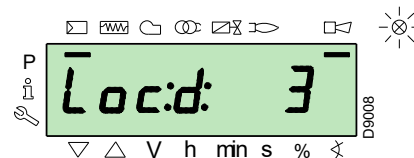
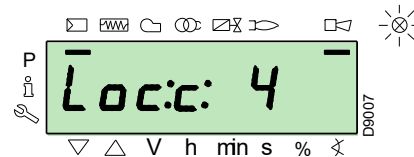

The display visualises alternately an error code and a diagnostic, which does not take the system into safety mode.

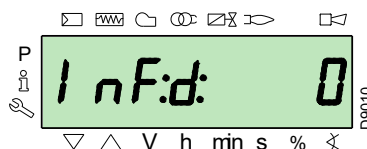
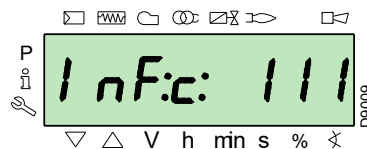

**5.8.1.5 Reset procedure**

The burner is in lockout when the red indicator light on the operator panel is lit up, and the display visualises the lockout code (in the example alongside **c: 4**) and the relative diagnostics (in the example **d: 3**) alternately.

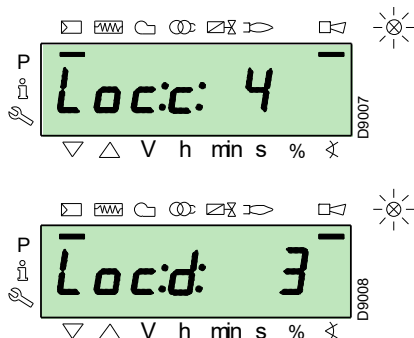

To reset, press the “i/reset” key for 1s: the display will show “RESET”. When the key is released, the lockout signal will disappear and the red indicator light will switch off.

The flame control is reset.

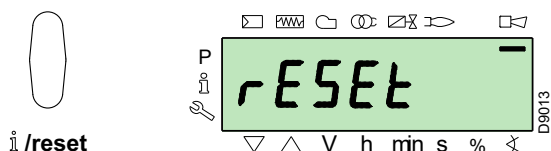

**5.8.1.6 Manual lockout procedure**

If necessary, it is possible to manually block the flame control and, consequently, the burner, by pressing the key “i/reset” simultaneously with any other key of the operator panel.



With the selector “OFF-ON” (Fig. 5 on page 11) the burner does not stop immediately, but the switch-off phase is activated.

**5.8.1.7 Manual operation procedure**

After the adjustment of the burner and the setting of the points on the modulation curve, it is possible to manually check the operation of the burner along the entire curve.

Example:

the burner is working at the requested load percentage: 20%.

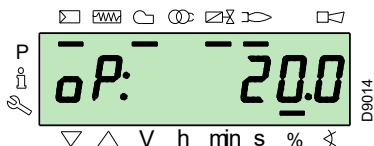

Press the “F” key for 1 second: “LoAd” is displayed and the load percentage flashes.

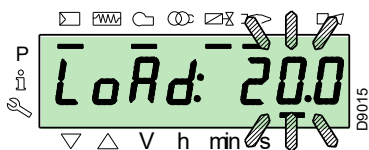

Releasing the “F” key, the standard visualisation appears, with the current load percentage flashing: this means that the burner is working in Manual mode (any outside adjustment is excluded and only the safety devices are active).

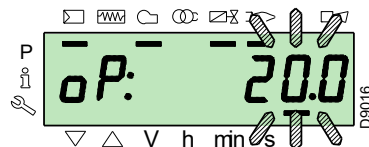

Keep the “F” key pressed and, with the keys “+” or “-”, increase or decrease the load percentage.

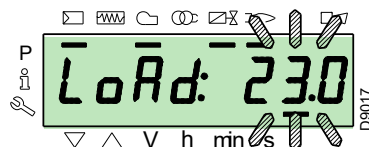

To exit manual mode, press the keys “+” and “-” (ESC) simultaneously for 3 seconds: the burner will work in Automatic mode and the output will depend on the thermostat/adjustment pressure switch (TR).

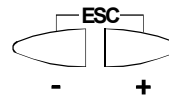

**5.8.2 Info mode**

The **Info mode (InFo)** visualises general system information. To access this level you must:

- press the “i/reset” key for 1-3 s.
- Release the key immediately when the display shows “InFo”.

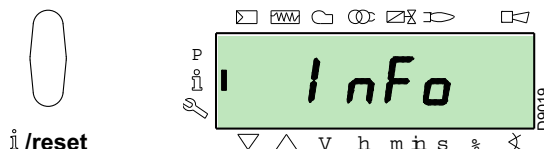

The list of parameters (in the sequence in which they are displayed) is shown in Tab. P.

No.	Parameter
167	Volumetric delivery of fuel in the unit of measurement selected
162	Operation time with flame
163	Operation time
164	No. of resettable ignitions
165	No. of ignitions
177	Fuel 1: Volumetric output of fuel in the unit of measurement selected
172	Fuel 1: Operation time with flame
174	Fuel 1: No. of resettable ignitions
175	Fuel 1: No. of ignitions
166	Total no. of ignitions
113	Identification code of the burner
107	Software version
108	Software variation
102	Flame control test date
103	Identification code of the flame control
104	Identification number of the group of parameters set
105	Version of the group of parameters set
143	Reserved
End	

**Tab. P**

**5.8.3 Service mode**

The **Service mode (SEr)** visualises the error log and certain technical information about the system. To access this level you must:

- press the **"i/reset"** key for more than 3 s.
- Release the key immediately when the display shows **"SEr"**.

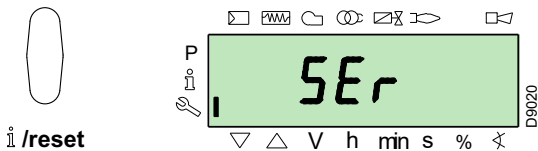

The list of parameters (in the sequence in which they are displayed) is shown in Tab. Q.

No.	Parameter
954	Flame intensity (%)
960	Actual fuel which passes in units of volume / h (m <sup>3</sup> /h, l/h, ft <sup>3</sup> /h, gal/h)
121	Manual setting of output Not defined = automatic operation
922	Position of the servomotors (expressed in degrees, symbol ☒) 0 = fuel 1 = air
161	Number of errors
701÷725	Log of the errors: 701-725.01, Code
945	Fuel in use: 0 = fuel 0 (oil) 1 = fuel 1 (gas)

**Tab. Q**

**5.8.3.1 Operating mode on Info Mode and Service Mode**

After access to these levels, the display visualises the number of the parameter (flashing) on the left, and the corresponding value on the right.

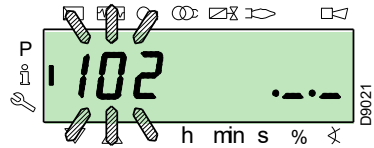

If the value is not displayed, press the **"i/reset"** key for a period of 1 to 3 seconds

To return to the Parameter List, press the **"i/reset"** key for more than 3 s, or press the keys **"+"** and **"-"** (ESC) simultaneously.

To move on to the next parameter, press the key **"+"** or **"i/reset"** for less than 1s. At the end of the list, the display visualises **"End"**.

To move back to the previous parameter, press the key **"-"**.

To return to the Normal/Standard Visualisation Mode, press the **"i/reset"** key for more than 3 s, or press the keys **"+"** and **"-"** (ESC) simultaneously.

For a moment the display will show **"OPERate"**.

**5.8.4 Parameters Mode**

The **Parameters Mode (PARa)** displays and allows you to modify/programme the parameters list on page 46.

The factory-set parameters are not visible.

To access this level, refer to **"Access procedure with password"**.

**5.8.4.1 Access procedure with password**

Press the **"F"** and **"A"** keys simultaneously for 1s.

For a moment the display will show **"CodE"**, and immediately after you will see 7 dashes, the first one flashing.

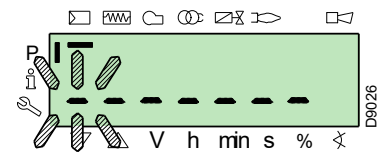
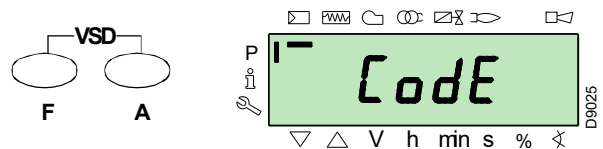

With the keys **"+"** and **"-"** select the first character of the password (letter or number), and confirm by pressing the key **"i/reset"**.

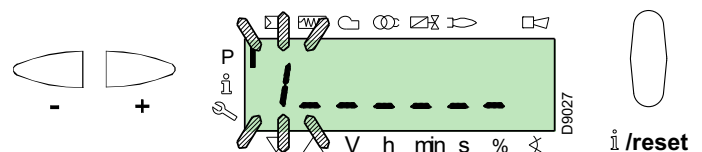

Once you have confirmed, the sign “-” will appear.

Continue in the same way for the other characters.

After inserting the last character of the password, confirm by pressing the key “i/reset”: if the password inserted is correct you will see “PArA” for a few seconds, then you can access the various groups of parameters.

With the keys “+” and “-” select the group you require.

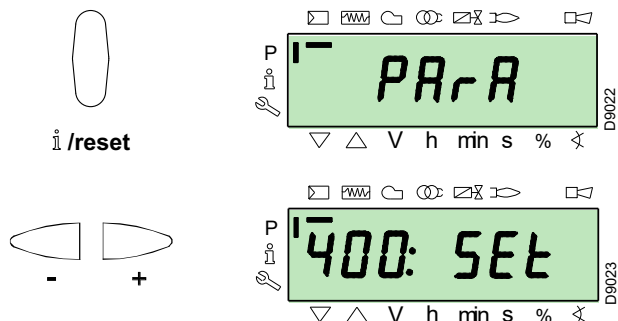

If the password inserted is incorrect, the message “Error” will appear for a moment. It is then necessary to repeat the procedure.



The password must only be communicated to the qualified personnel or the Technical Assistance Service, and must be kept in a safe place.

Once the access procedure has been carried out, the display will show “PArA” for a few seconds.

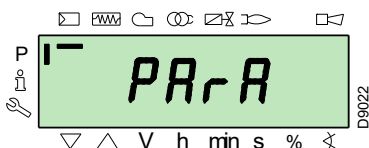

Select the desired group of parameters with keys “+” and “-”, and confirm by pressing the key “i/reset”.

Within the group you have chosen, scroll through the list with the keys “+” and “-”. At the end of the list, the display shows “End”.

To return to Normal visualisation mode, simultaneously press the keys “+” and “-” (ESC) twice.

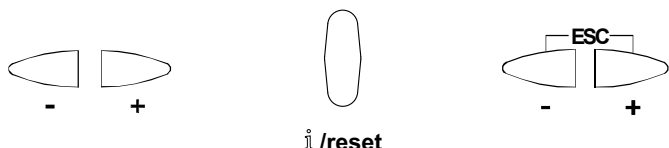

### 5.8.4.2 Assigning parameter levels

The parameters level is subdivided into groups as shown in Tab. R.

No.	Parameter
100: ParA	<b>General parameters</b> Information and identification data of the system.
200: ParA	<b>Burner checks (Fuel 0)</b> Type of operation, intervention and safety times of the various phases.
300: ParA	<b>Burner checks (Fuel 1)</b> Type of operation, intervention and safety times of the various phases.
400: Set	<b>Air/fuel modulation curve</b> Setting of air/fuel adjustment points
500: ParA	<b>Positioning of servomotors</b> Choice of positions of the air/fuel servomotors in the various phases.
600: ParA	<b>Servomotors</b> Setting and addressing of the servomotors.
700: HIST	<b>Log of the errors</b> Choice of different visualisation modes for the errors log.
900: dAtA	<b>Process information</b> Visualisation of information for the remote management of the burner.

Tab. R



WARNING

All the parameters are checked in the factory. Modification/tampering may compromise the good operation of the burner and cause injury to people or damage to things. In any case, modifications must be carried out by qualified personnel.

To modify a parameter, refer to paragraph “Parameter modification procedure”.

This procedure for example illustrates a single fuel (0). The same procedure is also valid with reference to Tab. R for fuel (1) also.

**5.9 Parameter modification procedure**

After accessing the level and group of parameters, the display visualises the number of the parameter (flashing) on the left, and the corresponding value on the right.

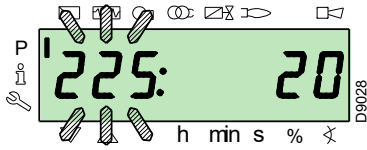

If the value is not visualised, press the key “i/reset for 1 - 3 seconds.

Find below an example of how to modify the parameter relating to the **pre-purging time** (No. 225).

Press the key “i/reset”: the value **20** (seconds) will appear.

**NOTE:**

The unit of measurement of the time is not visualised but is understood in seconds.

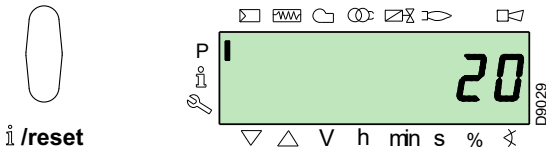

Press the key “+” and increase the value to **25** seconds (flashing). Press the key “i/reset” to confirm and store.

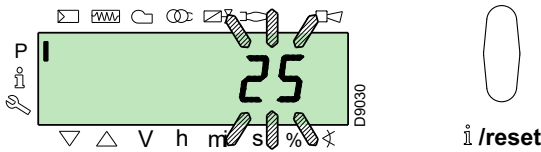

To return to the list of parameters, press the keys “+” and “-” (ESC) simultaneously.

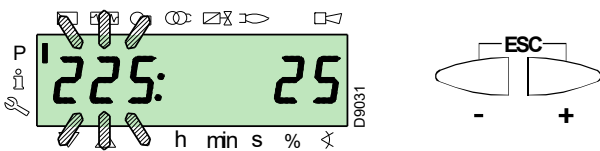

**5.9.0.1 Procedure for inserting and adjusting points on the modulation curve**

Nine adjustment/calibration points (P1 - P9) can be inserted in the flame control for each servomotor, varying their position by degrees and, consequently, the quantity of air and fuel introduced.

The **ignition point P0** is independent of the minimum modulation value. This means that, in the event of difficulty, it is possible to switch on the burner at a value other than the modulation minimum (**P1**).

To access the **Parameter mode** (group 400) referring to the Access procedure with password.

To insert or adjust a point, proceed as follows.

Using the keys “+” and “-” insert/select the curve point you want and wait for it to flash: this means that the servomotors are now positioned on the values shown on the display and which correspond to the point previously set.

It is now possible to insert/modify the position by degrees.



The set value does not require confirmation.



For the fuel servomotor, keep the key “F” pressed (the position in degrees flashes) and press the keys “+” or “-” to increase or decrease the value.



For the air servomotor, keep the key “A” pressed (the position in degrees flashes) and press the keys “+” or “-” to increase or decrease the value.



To adjust the speed of the inverter (expressed in % and that is 50 Hz = 100 %), keep the buttons “F” and “A” simultaneously pressed, the percentage position blinks and press buttons “+” or “-” to increase or decrease the value.

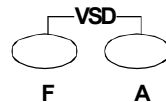

Select another point, or exit this area by pressing the keys “+” and “-” (ESC) simultaneously.

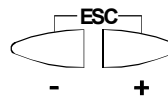

**5.9.0.2 CALC function**

The diagram (Fig. 47) shows how the fuel modulation curve is modified if the values of point “P5” are changed.

By keeping the “+” key pressed for more than 3 s, the points from “P6” to “P8” are recalculated.

By keeping the “-” key pressed for more than 3 s, the points from “P4” to “P2” are recalculated.

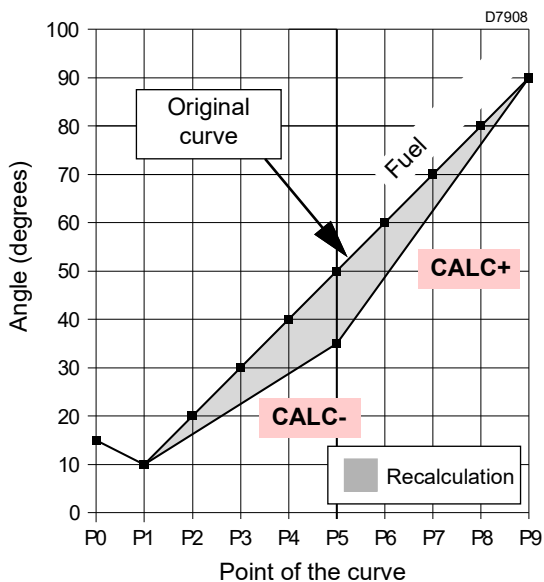

**Fig. 47**

The diagram of (Fig. 48) shows the fuel modulation curve when, after the modification of point “P5”, the recalibration of all the other points is not carried out.

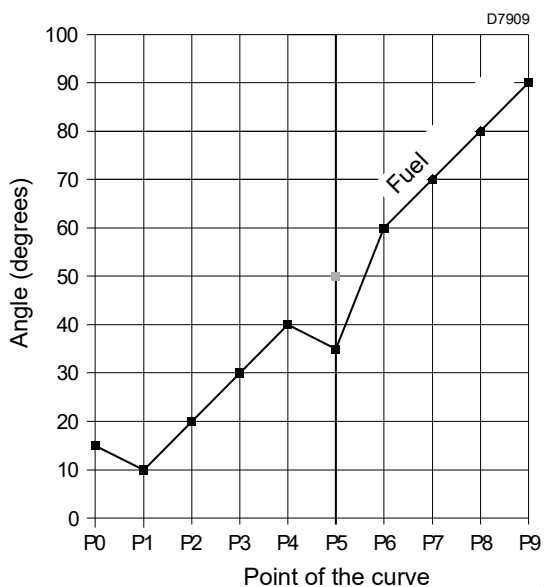

**Fig. 48**

**5.10 Start-up procedure**

Check that the Operator panel display shows the heat request and “OFF UP0” for fuel “0” or “OFF UP1” for fuel 1: this means it is necessary to set the modulation curve of the burner.

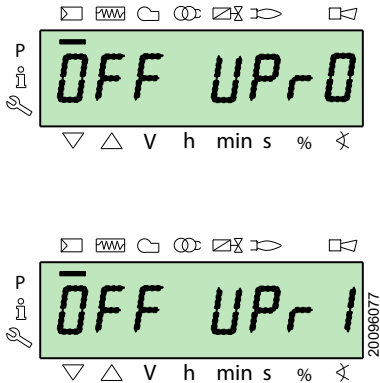

Access the Parameters Level referring to “Access procedure with password”. The display screen displays the parameters group 400.

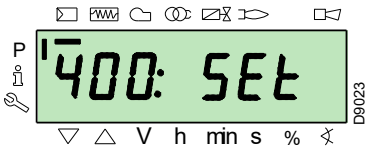

Confirm with the key “i/reset”



i/reset

The display shows “run”

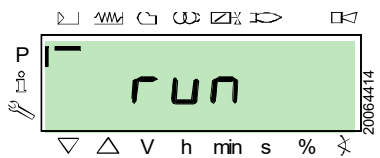

Confirm with the key “i/reset”. The burner starts up. The display shows all the phases and relative times in sequence. The phases are listed in the section List of the phases (gas operation).

**Phase 22:**

- Start of the fan motor.
- Pump motor start-up (only for oil operation).

**Phase 24:**

The burner goes to the pre-purging position, the air servomotor opens the damper at 90°.

**Phases 80, 81, 82, 83 (only with gas operation):**

These phases relate to the valve seal test.

**Phase 30:**

The count of the pre-purging time pre-set in the factory begins.

**Phase 36:**

The burner goes to its switch-on position, point “P0”, defined in Tab. S on page 43: the display shows a flashing “P0” indication. If the value proposed is adequate, confirm using the “+” button.

Otherwise, modify the ignition point (see the section Procedure for inserting and adjusting points on the modulation curve).

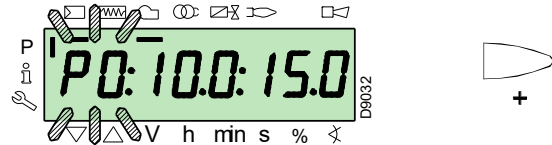

The values shown in the figure are purely for indication purposes.

**Phase 38:**

The ignition phase begins and the spark goes off.

**Phase 40:**

The fuel valves open (the safety time count begins). Using the appropriate visor check there is a flame and that the combustion parameters are correct. If necessary, vary the degrees of opening/closing of the air and fuel servomotors.



When operating with oil, the valves only open with the consent of the minimum oil pressure switch. If necessary adjust the minimum pressure switch or check the fuel flow.

If the flame control goes into lockout, press the keys “+” and “-” (ESC) simultaneously: the display visualises alternately the lock-out code for flame absence (c: 4) and the relative diagnostic (d: 3).

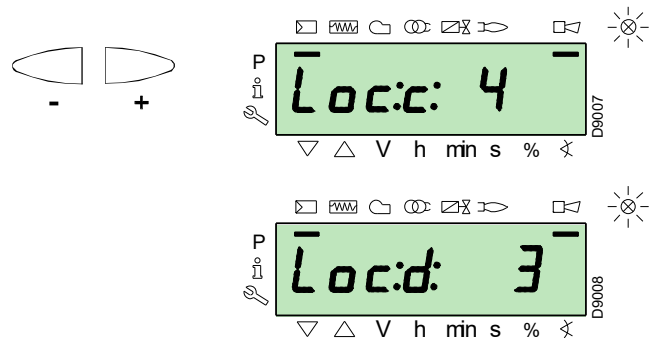

Solve the problem, referring to the paragraph Ignition failure.

To unlock, see Reset procedure. The display shows “OFF UP0” or “OFF UP1”

Repeat the “Start-up procedure”.



The values previously inserted remain stored.

Once the ignition has occurred (point “P0”), proceed with the calibration of the modulation curve.

Press the button “+”: the display visualises the indicator “P1” flashing and proposes the same settings as point “P0”.

Press button “+” again: the display shows “CALC” for a few seconds.

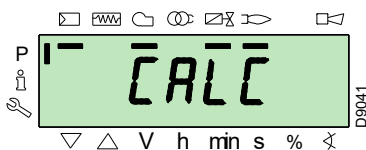

The flame control will automatically report the same values set in points “P0” and “P1” at points “P2” to “P8”.



The purpose of this is to reach point “P9” to regulate/determine the maximum operation output.

Press “+” until point “P9” is reached.

Once point “P9” is reached wait for the display to show the flashing indicator “P9” proposing the same settings as point “P0”.

Now it is possible to change this value to obtain the maximum operating power desired.

If the gas pressure is insufficient, despite opening the gas servomotor to a maximum of 90°, it is necessary to use the gas valve stabiliser.

After adjusting point “P9” keep the “-” key on the display pressed for about 5 seconds, “CALC” appears for a few seconds.

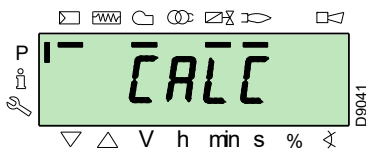

The flame control will automatically calculate the points from “P8” to “P2”, distributing them in a straight line. These are theoretical and must be checked.

Check that the settings of point “P8” are adequate.

If not, modify the point.

Proceed in sequence, with the “-” button, up to point “P1”.

It is possible to modify point “P1” to obtain a minimum modulation point different to the ignition point (“P0”).



Before moving on from one point to the next, wait for the servomotors to reach the position visualised on the display.

During the adjustment of each point, work on the air and gas servomotors, without modifying the position of the gas valve stabiliser.

Halfway through the procedure (i.e. around point P4 or P5), you are advised to measure gas delivery and check that the output is about 50% of the maximum output.

If this is not the case, work also on the gas valve stabiliser: in this case however, it is necessary to revise the calibrations of all the points previously set.

Once the calibration of point “P1” is completed, confirm by pressing the keys “+” and “-” (ESC) simultaneously: parameter “546” will appear.

If you want to make the burner work on the entire modulation curve, press the “+” and “-” (ESC) keys simultaneously: in this way, parameter “546” will automatically be assigned the value of 100% and parameter “545” will have a value of 20%.

If you want to make the burner work on just a part of the modulation curve, modify the parameters “546” and “545” according to the Parameter modification procedure.

Press the keys “+” and “-” (ESC) simultaneously twice, the display will show the current load position.

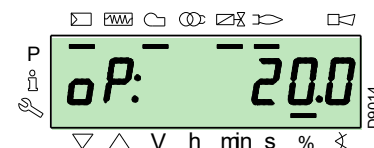
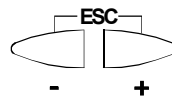

At the end of the “Start-up procedure” it is necessary to carry out a “Backup”, which is used to memorise the parameters and the data in the flame control within the display RDI21...

This operation allows the parameters and the points of the modulation curve to be restored in the event of problems.

It is advisable to perform a backup every time that a parameter is changed!

For the procedure see “Backup” on page 44.

**Factory settings**

		Point of the curve	Burner
Light oil	P0	air	15°
		fuel	17°
	P9	air / fuel	90°
Gas	P0	air	15°
		fuel	20°
	P9	air / fuel	90°

**Tab. S**

**5.11 Backup / Restore procedure**

At the end of the **Start-up procedure** it is wise to carry out a backup, creating a copy of the data memorised on the LMV 26..., in the RDI 21 display panel.

This will allow the data to be used for programming a new LMV 26... or to return to the memorised settings of the same LMV 26...



We suggest that this operation be carried out at the end of any intervention that involves modifications to what has been set on the cam.

This will allow you to carry out a restore in a simple manner on a new cam supplied as a replacement part, without having to reprogramme the system.

**5.11.1 Backup**

To perform the backup, proceed as follows:

- access the Parameters Level referring to Access procedure with password.

The display screen displays the parameters group **400**.

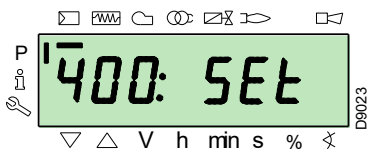

With the key “-”:



Select the parameters group **000**:

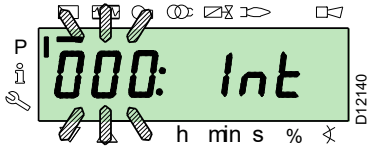

The **000** parameter blinks, confirm using the “i/reset” key:



i /reset

The display screen shows parameter **050** blinking:

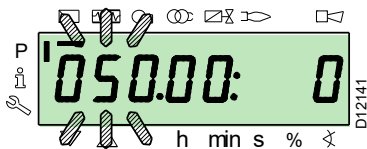

confirm with the key “i/reset”:



i /reset

The parameter **bAC\_UP** appears on the display screen:

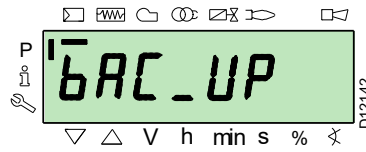

confirm with the key “i/reset”:



i /reset

The display screen shows the following value:

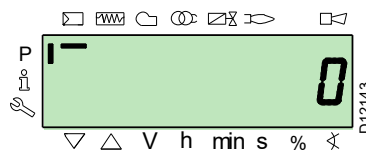

Use the button “+”:



The value will be set to **1**. Value 1 is flashing:

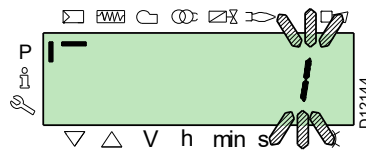

confirm with the button “i/reset” to activate the **backup** process.



i /reset

The value **1** appears on the display screen:

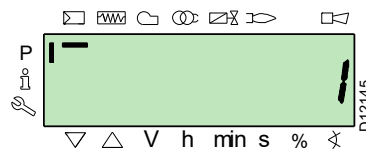

After approx 5 seconds (it depends on the duration of the programme), the 0 value appears on the display screen, this is to indicate that the backup process has been completed correctly.

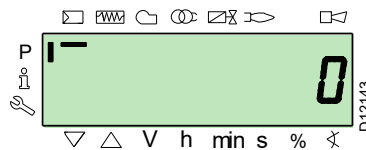

**NOTE:**

If an error occurs during the backup process, the display screen shows a negative value.

Refer to diagnostic code 137 to determine the cause of the error (see section List of parameters).



It is advisable to perform a backup every time that a parameter is changed, after checking that the modification carried out is correct.

**5.11.2 Restore**



Use this procedure when replacing equipment with a parts code. In this way it is possible to have the default parameters already memorised or those memorised during the start-up.

**This procedure cannot be carried out on equipment coming from other burners.**

To perform the restore procedure, proceed as follows:

- access the Parameters Level referring to Access procedure with password.

The display screen displays the parameters group **400**.

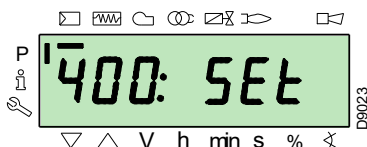

With the key “-”:



Select the parameters group **000**:

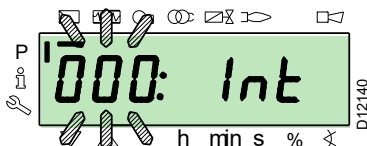

The **000** parameter blinks, confirm using the “i/reset” key:



i /reset

The display screen shows parameter **050** blinking:

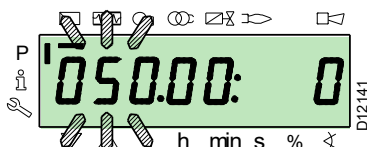

confirm with the key “i/reset”:



i /reset

The parameter **bAC\_UP** appears on the display screen:

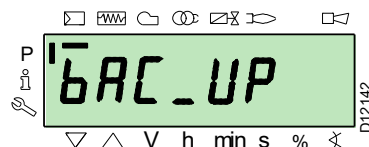

With the key “+”



select the **rEstorE** parameter

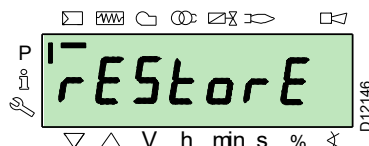

confirm with the key “i/reset”:



i /reset

The display shows the following value.



Use the button “+”:



The value will be set to **1**. Value 1 is flashing:



confirm with the button “i/reset” to activate the **restore** process.



i /reset

The value **1** appears on the display screen:



After approx 8 seconds (it depends on the duration of the programme), the **0** value appears on the display screen, this is to indicate that the restore process has been completed correctly.

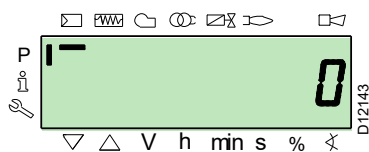

### NOTE:

**When the restore process is successfully completed, the 0 value is shown on the display screen. Err C information: 136 D: 1 (restore process initialised) is displayed for a brief moment.**



**At the end of the restore process, it is necessary to check the sequence of functions and the list of parameters.**

## 5.12 List of parameters

Parameter		No. of elements	Unit of measurement	Modification	Values interval		Degree of precision	Predefined setting	Access mode
No.	Description				Min.	Max.			
<b>000 INTERNAL PARAMETERS</b>									
050	Start backup/restore process via RDI21... / PC TOOL (set the parameter to 1) Index 0 = create backup Index 1 = perform restore Negative values indicate errors	2	-	Modification	-99	2	1	0; 0	Service mode
055	Burner identification number created from the backup on RDI21...	1	-	Reading only	0	99999999	1	0	Service mode
056	ASN number created by the backup on RDI21...	8	-	Reading only	0	127	1	0	Service mode
057	Software Version created by the backup on RDI21...	1	-	Reading only	0x100	0xFF9	1	0	Service mode
<b>100 GENERAL PARAMETERS</b>									
102	Flame control identification date	1	-	Reading only	0	255	1		Info mode
103	Flame control identification number	1	-	Reading only	0	65535	1		Info mode
104	Identification number of the group of parameters set	1	-	Reading only	0	255	1	30	Info mode
105	Version of the group of parameters set	1	-	Reading only	0	0xFFFF	1	V 01.08	Info mode
107	Software version	1	-	Reading only	0	0xFF9	1	V 03.30	Info mode
108	Software variation	1	-	Reading only	0	225	1	1	Info mode
111	ASN number to verify the ASN number created by the backup on RDI 21...	8	-	Reading only	0	127	1	0	Service mode
113	Burner identification	1	-	Modification	0	99999999	1	Not defined	Info Mode with password Service Mode
121	Manual setting of output Not defined = automatic operation	1	%	Modification / zero setting	0%	100%	0.1%	Not defined	Info mode
123	Minimum output step position Index 0: BACS output Index 1: output of the external load regulator, analogue. Index 2: output of the external load regulator contacts.	3	%	Modification	0%	100%	0.1%	0%; 1%; 0%	Modo Service
124	Beginning flame loss test (TÜV test)(define the parameter at 1)(switch of flame loss fuel valves) A negative value indicates an error (see code 150)	1	-	Modification	-6	1	1	0	Modo Service
125	Frequency of main power supply 0 = 50 Hz 1 = 60 Hz	1	-	Modification	0	1	1	0	Service Mode
126	Brightness of display	1	%	Modification	0%	100%	1%	75%	Service Mode
128	Fuel meter: Led pulse valence (led pulses / volumetric flow units)	1	-	Modification	0	400	0.01	0	Service Mode
130	Eliminate visualisation error chronology To eliminate the visualisation, set the parameter to 1, then to 2 Answer 0: process successful Answer -1: timeout of 1_2 - sequence	1	-	Modification	-5	2	1	0	Service Mode
133	Default output for TÜV test: Not valid for TÜV test when output is activated 2,000 ..... 10,000 = low flame or first / second / third stage	1	%	Modification / zero setting	20%	100%	0.1%	Not defined	Service Mode
141	Remote management of flame control 0 = off 1 = Modbus 2 = reserved	1	-	Modification	0	2	1	0	Service Mode

Parameter		No. of elements	Unit of measurement	Modification	Values interval		Degree of precision	Predefined setting	Access mode
No.	Description				Min.	Max.			
142	Standby time before a new attempt in event of communication fault Set values: 0 = not active 1 = .... 7200 s	1	s	Modification	0s	7200s	1s	120s	Service Mode
143	Reserved	1	-	Modification	1	8	1	1	Info Mode
144	Reserved	1	s	Modification	10s	60s	1s	30s	Service Mode
145	Peripheral address for Modbus Set values: 1 ... 247	1	-	Modification	1	247	1	1	Service Mode
146	Baud Rate for Modbus Set values: 0 = 9600 1 = 19200	1	-	Modification	0	1	1	1	Service Mode
147	Parity for Modbus 0 = none 1 = odd 2 = even	1	-	Modification	0	2	1	0	Service Mode
148	Selection of the burner operation during the interruption of the switch-over with the system of remote management. Set values: With <b>modulating operation</b> the settings of the values are the following: 0...19.9 = burner switched off 20...100 = 20...100% modulation field of the burner. With <b>stage operation</b> : 0 = burner off P1, P2, P3 No setting = no function in the event of communication interruption	1	%	Modification / zero setting	0%	100%	0.1%	Not defined	Service Mode
161	Total number of errors	1	-	Reading only	0	65535	1	0	Info mode
162	Hours of operation (that can be reset)	1	h	Reset	0 h	999999h	1 h	0h	Info mode
163	Total hours of power supply to flame control	1	h	Reading only	0h	999999h	1h	0h	Info mode
164	Total number of start-ups (that can be reset)	1	-	Reset	0	999999	1	0	Info mode
166	Total number of start-ups	1	-	Reading only	0	999999	1	0	Info mode
167	Volumetric delivery of fuel in the selected unit of measurement (that can be reset)	1	m <sup>3</sup> , l, ft <sup>3</sup> , gal	Reset	0	99999999	1	0	Info mode
<b>200 BURNER CHECKS (fuel 0)</b>									
201	Burner operation mode (fuel supply line, modulating/stage, servomotors, etc.) -- = not defined (eliminate curves) 1 = Gmod 2 = Gp1 mod 3 = Gp2 mod 4 = Lo mod 5 = Lo 2 stage 6 = Lo 3 stage 7 = Gmod pneu 8 = Gp1 mod pneu 9 = Gp2 mod pneu 10 = LoGp mod 11 = LoGp 2-stage 12 = Lo mod 2 fuel valves 13 = LoGp mod 2 fuel valves 14 = G mod pneu without actuator 15 = Gp1 mod pneu without actuator 16 = Gp2 mod pneu without actuator 17 = Lo 2-stage without actuator 18 = Lo 3-stage without actuator 19 = G mod only gas actuator 20 = Gp1 mod only gas actuator 21 = Gp2 mod only gas actuator 22 = Lo mod only oil actuator	1	-	Modify/set to zero	1	22	1	Not defined	Service Mode
208	Stopping of the program 0 = deactivated 1 = pre-purging (Ph24) 2 = Ignition (Ph36) 3 = Interval 1 (Ph44) 4 = Interval 2 (Ph52)	1	-	Modification	0	4	1	0	Service Mode
210	Alarm as the pre-purging phase begins; 0 = Deactivated; 1 = Activated	1	-	Modification	0	1	1	0	Service Mode

Parameter		No. of elements	Unit of measurement	Modification	Values interval		Degree of precision	Predefined setting	Access mode
No.	Description				Min.	Max.			
211	Uphill train fan motor	1	s	Modification	2s	60s	0.2s	2s	Service Mode
212	Maximum time to reach low flame	1	s	Modification	0.2s	10 min	0.2s	45s	Service Mode
215	Maximum repeats of safety circuit 1 = No repetition 2...15 = Number of repetitions 16 = Constant repetitions	1	-	Modification	1	16	1	16	Service Mode
221	Gas: selection of flame sensor 0 = QRB.../ QRC 1 = ION / QRA	1	-	Modification	0	1	1	1	Service Mode
222	Gas: Selection of the pre-purging function 0 = deactivated 1 = activated	1	-	Modification	0	1	1	1	Service Mode
223	Maximum repeats of minimum gas pressure switch intervention 1 = No repetition 2...15 = Number of repetitions 16 = Constant repetitions	1	-	Modification	1	16	1	16	Service Mode
225	Gas: pre-purging time	1	s	Modification	20s	60 min	0.2s	20s	Service Mode
226	Gas: pre-ignition time	1	s	Modification	0.4 s	60 min	0.2s	2s	Service Mode
230	Gas: interval 1	1	s	Modification	0.4 s	60s	0.2s	2s	Service Mode
232	Gas: interval 2	1	s	Modification	0.4 s	60s	0.2s	2s	Service Mode
233	Gas: post-combustion time	1	s	Modification	0.2s	60s	0.2s	8s	Service Mode
234	Gas: Post-purging time (no extraneous light test)	1	s	Modification	0.2s	108 min	0.2s	0.2s	Service Mode
236	Gas: Minimum gas pressure switch input 0 = deactivated 1 = minimum gas pressure switch (upstream of the fuel valve 1 (V1)) 2 = valve control via the minimum pressure switch (between fuel vale 1 (V1) and 2 (V2))	1	-	Modification	1	2	1	1	Service Mode
237	Gas: Maximum gas pressure switch / POC Input 0 = deactivated 1 = Maximum gas pressure switch 2 = POC 3 = Leak detection control pressure switch	1	-	Modification	1	2	1	1	Service Mode
241	Gas: Valve leak detection test 0 = test deactivated 1 = valve leak detection test at start up 2 = valve leak detection test at shutdown 3 = valve leak detection test at start-up and at shut-down	1	-	Modification	0	3	1	2	Service Mode
248	Gas: Post-purging time (t3)(at deactivation of the load (LR)) - ON	1	s	Modification	1s	108 min	0.2s	1s	Service Mode
261	Oil: selection of flame sensor 0 = QRB.../ QRC... 1 = ION / QRA...	1	-	Modification	0	1	1	0	Service Mode
265	Oil: pre-purging time	1	s	Modification	15s	60 min	0.2s	15s	Service Mode
266	Oil: pre-ignition time	1	s	Modification	0.6s	60 min	0.2s	2s	Service Mode
270	Oil: interval 1	1	s	Modification	0.4 s	60 min	0.2s	2s	Service Mode
272	Oil: interval 2	1	s	Modification	0.4 s	60 min	0.2s	2s	Service Mode
273	Oil: post-combustion time	1	s	Modification	0.2s	60s	0.2s	8s	Service Mode
274	Oil: Post-purging time (no extraneous light test)	1	s	Modification	0.2s	108 min	0.2s	0.2s	Service Mode
276	Oil: Minimum input oil pressure switch 0 = deactivated 1 = activated from phase 38 2 = activated from safety time (TSA)	1	-	Modification	1	2	1	1	Service Mode
277	Oil: Maximum oil pressure switch / POC Input 0 = deactivated 1 = Maximum oil pressure switch 2 = POC	1	-	Modification	1	2	1	1	Service Mode
281	Oil: selection transformer ignition phase TA 0 = brief pre-ignition (Ph38) 1 = long pre-ignition (with fan)(Ph22)	1	-	Modification	0	1	1	1	Service Mode
284	Oil: Post-purging time (t3)(at deactivation of the load (LR)) - ON	1	s	Modification	1s	108 min	0.2s	1s	Service Mode
<b>300</b>	<b>BURNER CHECKS (FUEL 1)</b>								

Parameter		No. of elements	Unit of measurement	Modification	Values interval		Degree of precision	Predefined setting	Access mode
No.	Description				Min.	Max.			
301	Burner operation mode (fuel supply line, modulating/ stage, servomotors, etc.) -- = not defined (eliminate curves) 1 = Gmod 2 = Gp1 mod 3 = Gp2 mod 4 = Lo mod 5 = Lo 2 stage 6 = Lo 3 stage 7 = Gmod pneu 8 = Gp1 mod pneu 9 = Gp2 mod pneu 10 = LoGp mod 11 = LoGp 2-stage 12 = Lo mod 2 fuel valves 13 = LoGp mod 2 fuel valves 14 = G mod pneu without actuator 15 = Gp1 mod pneu without actuator 16 = Gp2 mod pneu without actuator 17 = Lo 2-stage without actuator 18 = Lo 3-stage without actuator 19 = G mod only gas actuator 20 = Gp1 mod only gas actuator 21 = Gp2 mod only gas actuator 22 = Lo mod only oil actuator	1	-	Modify/set to zero	1	22	1	Not defined	Service Mode
321	(Fuel 1) Gas: selection of flame sensor 0 = QRB.../ QRC 1 = ION / QRA	1	-	Modification	0	1	1	1	Service Mode
322	(Fuel 1) Gas: Selection of the pre-purging function 0 = deactivated 1 = activated	1	-	Modification	0	1	1	1	Service Mode
323	Maximum repeats of minimum gas pressure switch intervention 1 = No repetition 2...15 = Number of repetitions 16 = Constant repetitions	1	-	Modification	1	16	1	16	Service Mode
325	(Fuel 1) Gas: pre-purging time	1	s	Modification	20s	60 min	0.2s	20s	Service Mode
326	(Fuel 1) Gas: Spark pre-ignition time	1	s	Modification	0.4 s	60 min	0.2s	2s	Service Mode
330	(Fuel 1) Gas: interval 1	1	s	Modification	0.4 s	60s	0.2s	2s	Service Mode
332	(Fuel 1) Gas: interval 2	1	s	Modification	0.4 s	60s	0.2s	2s	Service Mode
333	(Fuel 1) Gas: post-combustion time	1	s	Modification	0.2s	60s	0.2s	8s	Service Mode
334	(Fuel 1) Gas: Post-purging time (no extraneous light test)	1	s	Modification	0.2s	108 min	0.2s	0.2s	Service Mode
336	(Fuel 1) Gas: Minimum gas pressure switch input 0 = deactivated 1 = minimum gas pressure switch (upstream of the fuel valve 1 (V1)) 2 = valve control via the minimum pressure switch (between fuel vale 1 (V1) and 2 (V2))	1	-	Modification	1	2	1	1	Service Mode
337	(Fuel 1) Gas: Maximum gas pressure switch / POC Input 0 = deactivated 1 = Maximum gas pressure switch 2 = POC 3 = Leak detection control pressure switch	1	-	Modification	1	2	1	1	Service Mode
341	(Fuel 1) Gas: Valve leak detection test 0 = test deactivated 1 = valve leak detection test at start up 2 = valve leak detection test at shutdown 3 = valve leak detection test at start-up and at shutdown	1	-	Modification	0	3	1	2	Service Mode
348	(Fuel 1) Gas: Post-purging time (t3)(at deactivation of the load (LR)) - ON	1	s	Modification	1s	108 min	0.2s	1s	Service Mode
361	(Fuel 1) Oil: selection of flame sensor 0 = QRB.../ QRC... 1 = ION / QRA...	1	-	Modification	0	1	1	0	Service Mode
365	(Fuel 1) Oil: pre-purging time	1	s	Modification	15s	60 min	0.2s	15s	Service Mode
366	(Fuel 1) Oil: Spark pre-ignition time	1	s	Modification	0.6s	60 min	0.2s	2s	Service Mode
370	(Fuel 1) Oil: interval 1	1	s	Modification	0.4 s	60 min	0.2s	2s	Service Mode
372	(Fuel 1) Oil: interval 2	1	s	Modification	0.4 s	60 min	0.2s	2s	Service Mode
373	(Fuel 1) Oil: post-combustion time	1	s	Modification	0.2s	60s	0.2s	8s	Service Mode

Parameter		No. of elements	Unit of measurement	Modification	Values interval		Degree of precision	Predefined setting	Access mode
No.	Description				Min.	Max.			
374	(Fuel 1) Oil: Post-purging time (no extraneous light test)	1	s	Modification	0.2s	108 min	0.2s	0.2s	Service Mode
377	(Fuel 1) Oil: Maximum oil pressure switch / POC Input 0 = deactivated 1 = Maximum oil pressure switch 2 = POC	1	-	Modification	1	2	1	1	Service Mode
381	(Fuel 1) Oil: selection transformer ignition phase TA 0 = brief pre-ignition (Ph38) 1 = long pre-ignition (with fan)(Ph22)	1	-	Modification	0	1	1	1	Service Mode
384	(Fuel 1) Oil: Post-purging time (t3)(at deactivation of the load (LR)) - ON	1	s	Modification	1s	108 min	0.2s	1s	Service Mode
<b>400 AIR / FUEL MODULATION CURVES</b>									
401	Checking fuel servomotor (only setting of the curve)	13	(°)	Modification	0°	90°	0.1°	0°; 0°; 15°; Not defined	Service Mode
402	Checking air servomotor (only setting of the curve)	13	(°)	Modification	0°	90°	0.1°	0°; 90°; 45°; Not defined	Service Mode
<b>500 POSITIONING OF SERVOMOTORS</b>									
501	Position of the fuel servomotor in absence of flame Index 0 = standby position Index 1 = pre-purging position Index 2 = post-purging position	3	(°)	Modification	0°	90°	0.1°	0°; 0°; 15°	Service Mode
502	Position of the air servomotor in absence of flame Index 0 = standby position Index 1 = pre-purging position Index 2 = post-purging position	3	(°)	Modification	0°	90°	0.1°	0°; 90°; 45°	Service Mode
545	Minimum modulation limit Not defined = 20%	1	%	Modification / zero setting	20%	100%	0.1%	Not defined	Service Mode
546	Maximum modulation limit Not defined = 100%	1	%	Modification / zero setting	20%	100%	0.1%	Not defined	Service Mode
<b>600 SERVOMOTORS</b>									
606	Tolerance limit for position check (0.1°) Index 0 = fuel Index 1 = air More serious position error, where a defect has certainly been detected -> Stop range: (P 606 - 0.6°) a P606	2	(°)	Modification	0.5°	4°	0.1°	1.7°; 1.7°	Service Mode
645	Analogue exit configuration 0 = DC 0...10 V 1 = DC 2...10 V 2 = DC 0 / 2...10 V	1	-	Modification	0	2	1	2	Service Mode
<b>700 LOG OF THE ERRORS</b>									
701	Error chronology: 701-725.01.Code	25	-	Reading only	0	255	1	0	Info mode
•	Error chronology: 701-725.02.Diagnostic code	25	-	Reading only	0	255	1	0	Info mode
•	Error chronology: 701-725.03.Error class	25	-	Reading only	0	6	1	0	Info mode
•	Error chronology: 701-725.04.Phase	25	-	Reading only	0	255	1	0	Info mode
•	Error chronology: 701-725.05.Start-up meter	25	-	Reading only	0	99999999	1	0	Info mode
725	Error chronology: 701-725.06.Load	25	%	Reading only	0%	100%	0.1%	0%	Info mode
<b>900 PROCESS INFORMATION</b>									
903	Actual output Index 0 = fuel Index 1 = air	2	%	Reading only	0%	100%	0.1%	0%	Info mode
922	Position of the servomotors Index 0 = fuel Index 1 = air	2	(°)	Reading only	-50°	150°	0.01°	0°	Info mode
942	Heat source active 1 = output during the definition of the curves 2 = manual output 3 = BACS output 4 = analogue input output 5 = output of the external load regulator contacts	1	-	Reading only	0	255	1	0	Modo Service

Parameter		No. of elements	Unit of measurement	Modification	Values interval		Degree of precision	Predefined setting	Access mode									
No.	Description				Min.	Max.												
947	Result of the sampling of the contact (codified in bits) Bit 0.0 = 1: Minimum pressure switch Bit 0.1 = 2: Maximum pressure switch Bit 0.2 = 4: Pressure switch control valves Bit 0.3 = 8: Air pressure switch Bit 0.4 = 16: Open load check Bit 0.5 = 32: ON load check	2	-	Reading only	0	255	1	0	Info mode									
	Bit 0.6 = 64: Closed load check																	
	Bit 0.7 = 128: Safety circuit																	
	Bit 1.0 = 1: Safety valve																	
	Bit 1.1 = 2: Ignition																	
	Bit 1.2 = 4: Fuel valve 1																	
	Bit 1.3 = 8: Fuel valve 2																	
	Bit 1.4 = 16: Fuel valve 3/ pilot valve																	
	Bit 1.5 = 32: Reset																	
	Relay request status (coded in bits)																	
	950									Bit 0 = 1: Alarm	1	-	Reading only	0	255	1	0	Info mode
										Bit 1 = 2: Safety valve								
										Bit 2 = 4: Ignition								
										Bit 3 = 8: Fuel valve 1								
										Bit 4 = 16: Fuel valve 2								
Bit 5 = 32: Fuel valve 3/ pilot valve																		
954	Flame intensity	1	%	Reading only	0%	100%	1%	0%	Info mode									
960	Actual output	1	m <sup>3</sup> /h, l, h, ft <sup>3</sup> /h, gal/h	Reading only	0	6553.5	0.1	0	Info mode									
961	Status of external modules and visualisation	1	-	Reading only	0	255	1	0	Info mode									
981	Memory error: Code	1	-	Reading only	0	255	1	0	Info mode									
982	Memory error: diagnostic code	1	-	Reading only	0	255	1	0	Info mode									
992	Error indicators	10	-	Reset	0	0xFFFFFFFF FF	1	0	Modo Service									

Tab. T

## 5.13 Operation

### Burner without modulating operation kit

Once the start-up cycle is completed, the servomotor command moves on to the thermostat/pressure switch TR that controls the pressure or the temperature in the boiler.

- If the temperature or the pressure is low (so the thermostat/pressure switch TR is closed), the burner progressively increases the output as far as the MAX value (point "P9").
- If the temperature or the pressure increases as far as the opening of the thermostat/pressure switch TR, the burner progressively reduces the output as far as the MIN value (point "P1"). The sequence repeats endlessly.

- The burner stops when the heat request is less than the heat supplied by the burner at MIN output.
- The thermostat/pressure switch TL opens, the flame control carries out the switching off phase.
- The air damper closes completely to reduce heat losses to a minimum.

### Burner with modulating operation kit

See manual enclosed with the adjuster kit.

## 5.14 Ignition failure

If the burner does not switch on, there is a lockout within 3s of the electrical supply reaching the gas valve.

It may be that the gas does not arrive at the combustion head within the safety time of 3s.

In this case increase gas ignition delivery.

The arrival of gas to the pipe coupling is shown by the pressure gauge in Fig. 51.



WARNING

In the event the burner stops, in order to prevent any damage to the installation, do not unblock the burner more than twice in a row.

If the burner locks out for a third time, contact the customer service.



DANGER

In the event there are further lockouts or faults with the burner, the maintenance interventions must only be carried out by qualified, authorised personnel, in accordance with the contents of this manual and in compliance with the standards and regulations of current laws.

**5.15 Burner flame goes out during operation**

If the flame accidentally goes out during operation, the flame control carries out a recycle (i.e. it repeats the start-up phase once, and makes a further ignition attempt).  
If the flame is still absent, the flame control goes into lockout.

**5.16 Stopping of the burner**

The burner can be stopped by:

- intervening on the disconnecting switch of the electrical supply line, located on the boiler panel;
- position selector **"OFF/ON"** (Fig. 5 on page 11) to **"OFF"** (0);
- removing the transparent protection that covers the Operator Panel (after loosening the relative screw), and intervening on the Panel itself as explained in the "Manual lockout procedure".

**5.17 Measuring the flame signal**

The burner is fitted with a sensor to check that a flame is present. The minimum current for flame control operation is 70 µA. The operator Panel displays "30%" (see List of parameters, parameter 954).

The burner provides a much higher current, so controls are not normally required.

If, however, you want to measure the current of the flame sensor, follow the instructions as described in **"Maintenance programme"** on page 53.

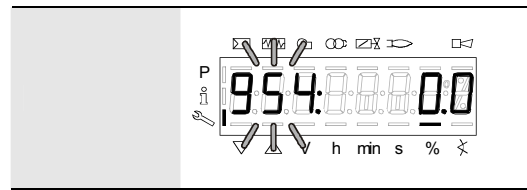

S8171

**Fig. 49**

**5.18 Final checks (with burner operating)**

<ul style="list-style-type: none"> <li>➤ Open the thermostat/pressure switch TL</li> <li>➤ Open the thermostat/pressure switch TS</li> </ul>	➡	The burner must stop
<ul style="list-style-type: none"> <li>➤ Turn the gas maximum pressure switch knob to the minimum end of scale position</li> <li>➤ Turn the air pressure switch to the maximum end of scale position</li> <li>➤ Turn the oil maximum pressure switch knob to the minimum end of scale position</li> </ul>	➡	The burner must stop in lockout
<ul style="list-style-type: none"> <li>➤ Turn off the burner and cut off the power</li> <li>➤ Disconnect the minimum gas pressure switch connector</li> <li>➤ Turn the oil minimum pressure switch knob to the maximum end of scale position</li> </ul>	➡	The burner must not start
<ul style="list-style-type: none"> <li>➤ Obscure the flame sensor</li> </ul>	➡	the burner must stop in lockout due to flame loss

**Tab. U**



Make sure that the mechanical locking systems on the various adjustment devices are fully tightened.

## 6 Maintenance

### 6.1 Notes on safety for the maintenance

The periodic maintenance is essential for the good operation, safety, yield and duration of the burner.

It allows you to reduce consumption and polluting emissions and to keep the product in a reliable state over time.



The maintenance interventions and the calibration of the burner must only be carried out by qualified, authorised personnel, in accordance with the contents of this manual and in compliance with the standards and regulations of current laws.

Before carrying out any maintenance, cleaning or checking operations:



Turn off the burner's electrical supply using the main system switch.

Make sure that both electrical supplies have been disconnected.



Turn off the fuel interception tap.



Wait for the components in contact with heat sources to cool down completely.

### 6.2 Maintenance programme

#### 6.2.1 Maintenance frequency



The gas combustion system should be checked at least once a year by a representative of the manufacturer or another specialised technician.

#### 6.2.2 Safety test - with gas ball valve closed

It is fundamental to ensure the correct execution of the electrical connections between the gas solenoid valves and the burner to perform safely the commissioning.

For this purpose, after checking that the connections have been carried out in accordance with the burner's electrical diagrams, an ignition cycle with closed gas ball valve -dry test- must be performed.

- 1 The manual ball gas valve must be closed
- 2 The electrical contacts of the burner limit switch need to be closed
- 3 Ensures closed the contact of the low gas pressure switch
- 4 Make a trial for burner ignition

The start-up cycle must be as follows:

- Starting the fan for pre-ventilation
- Performing the gas valve seal control, if provided
- Completion of pre-ventilation
- Arrival of the ignition point
- Power supply of the ignition transformer
- Electrical Supply of solenoid gas valves

Since the manual gas ball valve is closed, the burner will not light up and its flame control will go to a safety lockout condition.

The actual electrical supply of the solenoid gas valves can be verified by inserting a tester. Some valves are equipped with light signals (or close/open position indicator) that turn on at the same time as their power supply.



**IF THE ELECTRICAL SUPPLY OF THE GAS VALVES OCCURS AT UNEXPECTED TIMES, DO NOT OPEN MANUAL GAS BALL VALVE, SWITCH OFF POWER LINE; CHECK THE WIRES; CORRECT THE ERRORS AND REPEAT THE COMPLETE TEST.**

#### 6.2.3 Checking and cleaning



The operator must use the required equipment during maintenance.

##### Combustion

The optimum calibration of the burner requires an analysis of the flue gases.

Significant differences with respect to the previous measurements indicate the points where most care should be exercised during maintenance.

##### Combustion head

Open the burner and make sure that all the components of the combustion head are:

- undamaged;
- not deformed due to high temperature;
- free of ambient dirt or dust;
- free of rusted materials;
- adequately positioned.

Check the gas outlet holes for the ignition phase (in the distributor of the combustion head) are free of impurities or rust.

##### Burner

Clean the outside of the burner.

##### Fan

Check to make sure that no dust has accumulated inside the fan or on its impellers, as this condition will cause a reduction in the air flow rate and provoke polluting combustion.

##### Boiler

Clean the boiler as indicated in its accompanying instructions in order to maintain all the original combustion characteristics intact, especially: the flue gas temperature and combustion chamber pressure.

**Electrical current to flame sensor**

Clean the glass cover from any dust that may have accumulated. To remove the sensor, pull out outwards; it is only pressed in. Min value for a good work: 70  $\mu$ A.

If the value is lower, it could be due to:

- exhausted sensor
- low voltage (lower than 187 V)
- bad regulation of the burner

In order to measure the current, use a microammeter of 100  $\mu$ A d.c., connected in series to the sensor, as in the scheme, with a capacitor of 100  $\mu$ F - 1V d.c. at the same level of the instrument.

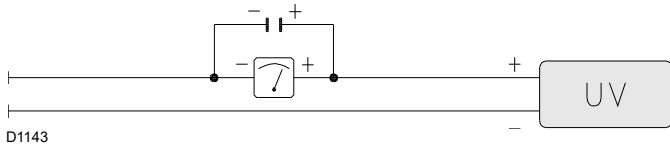

**Fig. 50**

**LIGHT OIL OPERATION**

**Pump**

The depression must be less than 0.45 bar.  
Unusual noise must not be evident during pump operation.  
 If the pressure is found to be unstable or if the pump runs noisily, the flexible hose must be detached from the line filter and the fuel must be sucked from a tank located near the burner.  
 This measure permits the cause of the anomaly to be traced to either the suction piping or the pump.  
 If the problem lies in the suction line, check the filter is clean and that air is not entering the piping.

**Filters**

Check the filtering baskets on line and at nozzle present in the system.  
 Clean or replace if necessary.  
 If rust or other impurities are observed inside the pump, use a separate pump to lift any water and other impurities that may have deposited on the bottom of the tank.

**Nozzles**

It is advisable to replace nozzles once a year during periodical maintenance.  
 Do not clean the nozzle openings.

**Hoses**

Check that these are in good conditions.

**Fuel tank**

Approximately every 5 years, suck any water on the bottom of the tank using a separate pump.

**Combustion**

In case the combustion values found at the beginning of the intervention do not respect the standards in force or, in any case, do not correspond to a proper combustion, contact the Technical Assistance Service in order to carry out the necessary adjustments.

EN 267	Air excess		CO
	Max. output $\lambda \leq 1.2$	Min. output $\lambda \leq 1.3$	
Theoretical max CO <sub>2</sub> 0 % O <sub>2</sub>	CO <sub>2</sub> % Calibration		mg/kWh
	$\lambda = 1.2$	$\lambda = 1.3$	
15.2	12.6	11.5	$\leq 100$

**Tab. V**

**GAS OPERATION**

**Gas leaks**

Make sure that there are no gas leaks on the pipe between the gas meter and the burner.

**Gas filter**

Change the gas filter when it is dirty.

**Combustion**

In case the combustion values found at the beginning of the intervention do not respect the standards in force or, in any case, do not correspond to a proper combustion, contact the Technical Assistance Service in order to carry out the necessary adjustments.

EN 676	GAS	Theoretical max CO <sub>2</sub> 0 % O <sub>2</sub>	Air excess		CO
			Max. output $\lambda \leq 1.2$	Max. output $\lambda \leq 1.3$	
			CO <sub>2</sub> % Calibration		mg/kWh
			$\lambda = 1.2$	$\lambda = 1.3$	
	G 20	11.7	9.7	9	$\leq 100$
	G 25	11.5	9.5	8.8	$\leq 100$
	G 30	14.0	11.6	10.7	$\leq 100$
	G 31	13.7	11.4	10.5	$\leq 100$

**Tab. W**

**6.2.4 Checking the air and gas pressure on the combustion head**

To carry out this operation it is necessary to use a pressure gauge to measure the air and gas pressure at the combustion head, as shown in Fig. 51.

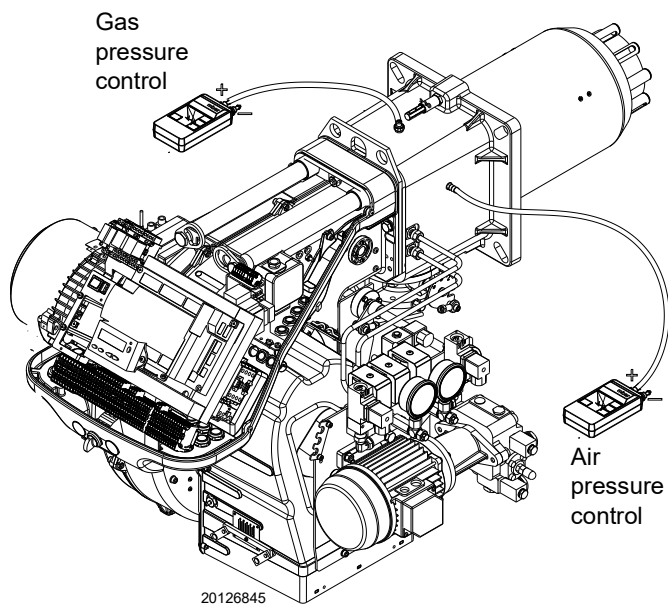

**Fig. 51**

**6.2.5 Safety components**

The safety components must be replaced at the end of their life cycle indicated in Tab. X.

The specified life cycles do not refer to the warranty terms indicated in the delivery or payment conditions.

Safety component	Life cycle
Flame control	10 years or 250,000 operation cycles
Flame sensor	10 years or 250,000 operation cycles
Gas valves (solenoid)	10 years or 250,000 operation cycles
Pressure switches	10 years or 250,000 operation cycles
Pressure adjuster	15 years
Servomotor (electronic cam) (if present)	10 years or 250,000 operation cycles
Oil valve (solenoid) (if present)	10 years or 250,000 operation cycles
Oil regulator (if present)	10 years or 250,000 operation cycles
Oil pipes/ couplings (metallic) (if present)	10 years
Fan impeller	10 years or 500,000 start-ups

**Tab. X**

### 6.3 Opening the burner



DANGER

Turn off the burner's electrical supply using the main system switch.

Make sure that both electrical supplies have been disconnected.



DANGER

Turn off the fuel interception tap.



Wait for the components in contact with heat sources to cool down completely.

- Loosen the 4 screws 1)(Fig. 52) and remove the hood 2).
- Disconnect the light oil pipes using the fittings 3).
- Disconnect the tie-rod 4) from the sector 5).
- Assemble the supplied extensions on the sliding bars 6).
- Fit the screws 10).
- Disconnect the socket from the maximum gas pressure switch.
- Remove the screws 7) and move the burner backwards by about 100 mm on the slide bars 6).
- Disconnect the probe and electrode leads and then pull the burner fully back.

At this point it is possible to extract the inner part 8) after having removed the screw 9).

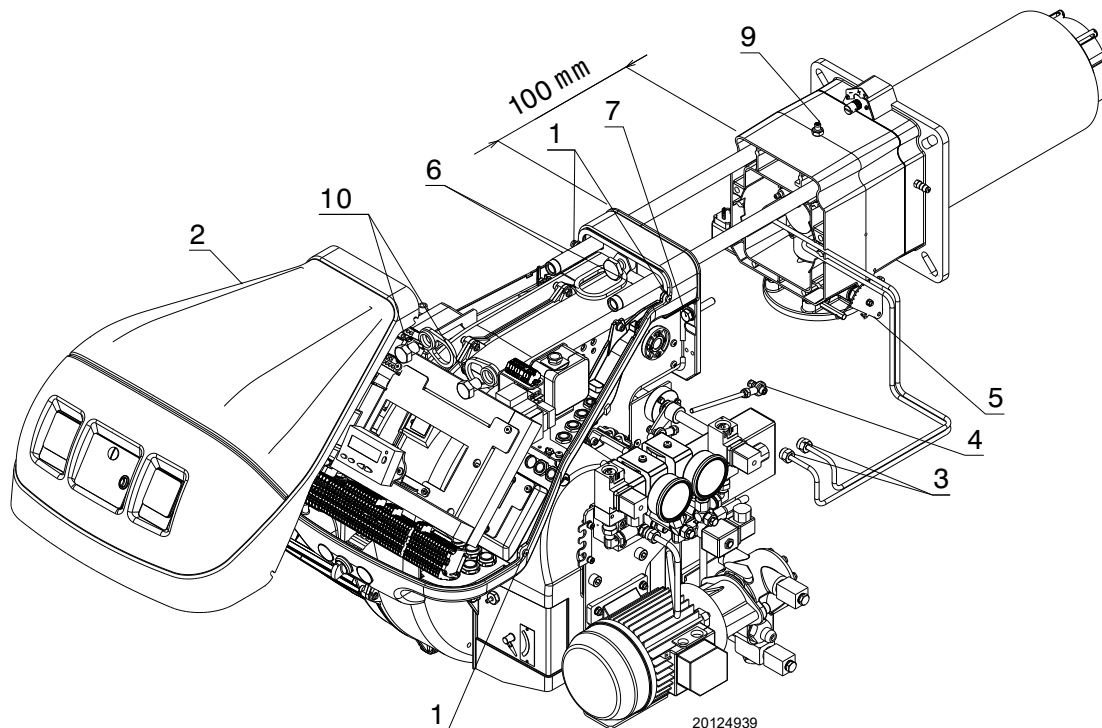

Fig. 52

### 6.4 Closing the burner

- Push the burner to approximately 100 mm from the pipe coupling.
- Disassemble the two extensions from the slide bars 6)(Fig. 52).
- Tighten the screws 10) on the slide bars of the burner.
- Reconnect the cables and slide in the burner until it comes to a stop.
- Connect the socket of the maximum gas pressure switch.
- Replace the screws 7) and carefully pull the probe and electrode cables outwards until they are slightly taut.
- Connect the tie-rod 4) from the sector 5).
- Connect the light oil pipes using the fittings.



After carrying out maintenance, cleaning or checking operations, reassemble the cover and all the safety and protection devices of the burner.

**7** Faults - Probable causes - Solutions

If faults arise in ignition or operations, the burner performs a "safety stop", which is signalled by the red burner lockout LED.

The display of the operator panel visualises alternately the lock-out code and the relative diagnostic.

To restore start-up conditions, refer to the Reset procedure.

When the burner starts up again, the red LED goes out.



In the event the burner stops, in order to prevent any damage to the installation, do not unblock the burner more than twice in a row.

If the burner locks out for a third time, contact the customer service.



In the event there are further lockouts or faults with the burner, the maintenance interventions must only be carried out by qualified, authorised personnel, in accordance with the contents of this manual and in compliance with the standards and regulations of current laws.

**7.1** List of error codes

Error code	Diagnostic code	Meaning of the LMV 26... system	Recommended measures
<b>No Comm</b>		<b>No communication between LMV 26... and RDI21...</b>	Check the wiring between the flame control LMV 26... and display RDI21...
<b>2</b>	<b>#</b>	<b>No flame at the end of TSA1</b>	
	1	No flame at the end of safety time 1 (TSA1)	
	2	No flame at the end of safety time 2 (TSA2)	
	4	No flame at the end of safety time 1 (TSA1) (software version ≤ V02.00)	
<b>3</b>	<b>#</b>	<b>Air pressure error</b>	
	0	Air pressure switch off	
	1	Air pressure switch on	
	4	Air pressure on – Lockout alarm at start	
	20	Air pressure, fuel pressure on - Alarm lock at start	
	68	Air pressure, POC on – Alarm lockout at start	
	84	Air pressure, fuel pressure, POC on - Alarm lockout at start	
<b>4</b>	<b>#</b>	<b>Extraneous light</b>	
	0	Extraneous light during start-up	
	1	Extraneous light during switch-off	
	2	Extraneous light during start-up – Lockout alarm at start	
	6	Extraneous light during start-up, air pressure - Alarm lockout at start	
	18	Extraneous light during start-up, fuel pressure - Alarm lockout at start	
	24	Extraneous light during start-up, air pressure, fuel pressure - Alarm lockout at start	
	66	Extraneous light during start-up, POC – Alarm lockout at start	
	70	Extraneous light during start-up, air pressure, POC - Alarm lockout at start	
	82	Extraneous light during start-up, fuel pressure, POC - Alarm lockout at start	
	86	Extraneous light during start-up, air pressure, fuel pressure, poc - Alarm lockout at start	
<b>7</b>	<b>#</b>	<b>Loss of flame</b>	
	0	Loss of flame	
	3	Flame loss (software version ≤ V02.00)	
	3...255	Flame loss during TÜV test (flame loss test)	The diagnostics covers the period of time from the closure of the fuel valves to the point the flame loss was detected (resolution 0.2 s → value 5 = 1 s).
<b>12</b>	<b>#</b>	<b>Valve leak detection control</b>	
	0	V1 leaks	<u>Leak test</u> Check if the valve on the side of the gas has any leaks. Check the wiring and make sure that the circuit is open.

Error code	Diagnostic code	Meaning of the LMV 26... system	Recommended measures
	1	V2 leaks	Leak test Check if the valve on the side of the burner has any leaks. Check if the pressure switch for the leak test (PGVP) is closed when gas pressure is not present. Check the wiring and check if there is a short circuit.
	2	Valve leak detection test not possible	The valve leak detection is active, but the minimum gas pressure switch is selected as input for X9-04 (check parameters 238 and 241)
	3	Valve leak detection test not possible	The valve leak detection is active, but no input has been assigned (check parameters 236 and 237)
	4	Valve leak detection not possible	Valve leak detection is active, but 2 inputs have already been assigned (configure parameter 237 or maximum gas Pressure switch or POC)
	5	Valve leak detection not possible	The valve leak detection is active, but 2 inputs have been assigned (check parameters 236 and 237)
<b>14</b>	<b>#</b>	<b>POC</b>	
	0	POC Open	Check if the closure contact of the valve is closed
	1	POC Closed	Check the wiring Check if the closure contact of the valve opens when the valve is checked
	64	POC Open - Alarm lockout at start	Check the wiring Check if the closure contact of the valve is closed
<b>19</b>	80	Fuel pressure, POC - Alarm lockout at start	Check that the pressure switch is closed when no pressure is present from the fuel Check that there are no short-circuits
<b>20</b>	<b>#</b>	<b>Pmin</b>	
	0	Minimum gas/oil pressure absent	Check that there are no line interruptions
	1	Scarcity of gas - Alarm lockout at start	Check that there are no line interruptions
<b>21</b>	<b>#</b>	<b>Pmax/POC</b>	
	0	Pmax: Max. gas/oil pressure exceeded POC: POC open (software version ≤ V02.00)	Check the wiring. POC: check whether the closure contact of the valve is closed
	1	POC closed (software version ≤ V02.00)	Check the wiring. Check if the closure contact of the valve opens when the valve is checked
	64	POC Open - Lockout alarm at the start (software version ≤ V02.00)	Check the wiring. Check if the contact of the valve opens when the valve is checked
<b>22 OFF S</b>	<b>#</b>	<b>Safety circuit/Burner flange</b>	
	0	Safety circuit open /Burner flange open	
	1	Safety circuit open /Burner flange open - Alarm lockout at start	
	3	Safety circuit open /Burner flange open, extraneous light - Alarm lockout at start	
	5	Safety circuit open /Burner flange open, extraneous light - Alarm lockout at start	
	17	Safety circuit open /Burner flange open, extraneous light - Alarm lockout at start	
	19	Safety circuit open /Burner flange open, extraneous light - Alarm lockout at start	
	21	Safety circuit open /Burner flange open, extraneous light - Alarm lockout at start	
	23	Safety circuit open /Burner flange open, extraneous light, air pressure, fuel pressure - Alarm lockout at start	
	65	Safety circuit /Burner flange open, POC - Alarm lockout at start	
	67	Safety circuit open /Burner flange open, extraneous light, POC - Alarm lockout at start	
	69	Safety circuit open /Burner flange open, air pressure, POC - Alarm lockout at start	
	71	Safety circuit open /Burner flange open, extraneous light, air pressure, POC - Alarm lockout at start	
	81	Safety circuit open /Burner flange open, fuel pressure, POC - Alarm lockout at start	
	83	Safety circuit open /Burner flange open, extraneous light, air pressure, POC - Alarm lockout at start	

Error code	Diagnostic code	Meaning of the LMV 26... system	Recommended measures
	85	Safety circuit open /Burner flange, air pressure, fuel pressure, POC - Alarm lockout at start	
	87	Safety circuit open /Burner flange, extraneous light, air pressure, fuel pressure, POC - Alarm lockout at start	
<b>50 ÷ 58</b>	<b>#</b>	<b>Internal error</b>	Carry out a reset; if the error arises repeatedly, replace the flame control
<b>60</b>	<b>0</b>	<b>Internal error: no valid load checking device</b>	Carry out a reset; if the error arises repeatedly, replace the flame control
<b>65 ÷ 67</b>	<b>#</b>	<b>Internal error</b>	Carry out a reset; if the error arises repeatedly, replace the flame control
<b>70</b>	<b>#</b>	<b>Fuel/air checking error: Calculation position in modulation</b>	
	23	Invalid load	No valid load
	26	Curve points not defined	Adjust the curve points of all the actuators
<b>71</b>	<b>#</b>	<b>Special position not defined</b>	
	0	Standby position	Set the standby position of all the servomotors used
	1	Pre-purging position	Set the pre-purging position of all the servomotors used
	2	Post-purging position	Set the post-purging position of all the servomotors used
	3	Ignition position	Set the ignition position of all the servomotors used
<b>72</b>	<b>#</b>	<b>Fuel/air internal checking error</b>	Carry out a reset; if the error arises repeatedly, replace the flame control
<b>73</b>	<b>#</b>	<b>Fuel/air internal checking error: multistep calculation position</b>	
	23	Position calculation, invalid stage load	No valid load
	26	Position calculation, stage curve points not defined	Adjust the curve points of all the servomotors
<b>75</b>	<b>#</b>	<b>Fuel/air ratio internal checking error: cyclical data check</b>	
	1	Check synchronisation data, different current load	
	2	Check synchronisation data, different target load	
	4	Check synchronisation data, different target positions	
	16	Check synchronisation data, different positions reached	
<b>76</b>	<b>#</b>	<b>Fuel/air internal checking error</b>	Carry out a reset; if the error arises repeatedly, replace the flame control
<b>85</b>	<b>#</b>	<b>Reference error of a servomotor</b>	
	0	Reference error of the fuel servomotor	The reference of the fuel servomotor was not successful. It was not possible to reach the reference point. 1. Check if the servomotors have been inverted. 2. Check if the servomotor is blocked or overloaded.
	1	Reference error of the air servomotor	The reference of the air servomotor was not successful. It was not possible to reach the reference point. 1. Check if the servomotors have been inverted. 2. Check if the servomotor is blocked or overloaded.
	Bit 7 Valence $\geq 128$	Reference error owing to parameter modification	The parameterisation of an actuator (e.g. the reference position) has been modified. This error will be visualised to start up a new reference.
<b>86</b>	<b>#</b>	<b>Fuel servomotor error</b>	
	0	Position error	It was not possible to reach the target position within the requested tolerance range. 1. Check if the servomotor is blocked or overloaded.
	Bit 0 Valence 1	Circuit open	Circuit open shown on the servomotor connection. 1. Check the wiring (the voltage between pin 5 or 6 and 2 of the X54 connector must be $> 0.5$ V).
	Bit 3 Valence $\geq 8$	Curve too steep in terms of train ratio	The slope of the curve can correspond to a maximum position modification of $31^\circ$ between 2 points of the modulation curve.
	Bit 4 Valence $\geq 16$	Deviation of section compared with the last reference	Overloading of the servomotor or servomotor subjected to mechanical torsion. 1. Check if the servomotor is blocked in any point along its range of action. 2. Check if the torque is sufficient for the application.
<b>87</b>	<b>#</b>	<b>Air servomotor error</b>	
	0	Position error	It was not possible to reach the target position within the requested tolerance range. 1. Check if the servomotor is blocked or overloaded.
	Bit 0 Valence 1	Circuit open	Circuit open shown on the servomotor connection. 1. Check the wiring (the voltage between pin 5 or 6 and 2 of the X54 connector must be $> 0.5$ V).

Error code	Diagnostic code	Meaning of the LMV 26... system	Recommended measures
	Bit 3 Valence $\geq 8$	Curve too steep in terms of train ratio	The slope of the curve can correspond to a maximum position modification of 31° between 2 points of the modulation curve.
	Bit 4 Valence $\geq 16$	Deviation of section compared with the last reference	Overloading of the servomotor or servomotor subjected to mechanical torsion. 1. Check if the servomotor is blocked in any point along its range of action. 2. Check if the torque is sufficient for the application.
<b>90 - 91</b>	<b>#</b>	<b>Burner internal checking error</b>	
<b>93</b>	<b>#</b>	<b>Flame signal acquisition error</b>	
	3	Short circuit of the sensor	Short circuit in the QRB sensor... 1. Check the wiring. 2. Flame detector probably faulty.
<b>95</b>	<b>#</b>	<b>Relay supervision error</b>	
	3 Ignition transformers 4 Fuel valve 1 5 Fuel valve 2 6 Fuel valve 3	External power supply - Contact active	Check the wiring
<b>96</b>	<b>#</b>	<b>Relay supervision error</b>	
	3 Ignition transformers 4 Fuel valve 1 5 Fuel valve 2 6 Fuel valve 3	The relay contacts have joined together	Check the contacts: 1. flame control connected to the power supply: the fan output must be without voltage. 2. Disconnect the power supply. Disconnect the fan. The resistive connection between the fan output and the neutral wire is not allowed. If one of the 2 tests fails, replace the flame control because the contacts are definitively joined together and it is no longer possible to guarantee safety.
<b>97</b>	<b>#</b>	<b>Relay supervision error</b>	
	0	The safety relay contacts have joined together or the safety relay has been powered by an external power supply	Check the contacts: 1. flame control connected to the power supply: the fan output must be without voltage. 2. Disconnect the power supply. Disconnect the fan. The resistive connection between the fan output and the neutral wire is not allowed. If one of the 2 tests fails, replace the flame control because the contacts are definitively joined together and it is no longer possible to guarantee safety.
<b>98</b>	<b>#</b>	<b>Relay supervision error</b>	
	2 - Safety valve 3 Ignition transformers 4 Fuel valve 1 5 Fuel valve 2 6 Fuel valve 3	The relay does not start up	Carry out a reset; if the error arises repeatedly, replace the unit
<b>99</b>	<b>#</b>	<b>Relay internal checking error</b>	Carry out a reset; if the error arises repeatedly, replace the flame control
	3	Relay internal checking error	Carry out a reset; if the error arises repeatedly, replace the flame control Software version V03.10: If error C:99 D:3 occurs during the standardisation of the VSD, temporarily deactivate the Alarm function at the start of the pre-purging phase (parameter 210 = 0) or interrupt the signal controller-ON
<b>100</b>	<b>#</b>	<b>Relay internal checking error</b>	Carry out a reset; if the error arises repeatedly, replace the flame control
<b>105</b>	<b>#</b>	<b>Contact sampling internal error</b>	
	0 Min. pressure switch 1 Max. pressure switch 2 Valve operation test pressure switch 3 Air pressure 4 Load controller open 5 Load controller on/off 6 Load controller closed 7 Safety loop / burner flange 8 Safety valve 9 Ignition transformers 10 Fuel valve 1 11 Fuel valve 2 12 Fuel valve 3 13 Reset	Blocked upon irregularity	Can be caused by capacitive loads or presence of DC voltage on the main power supply of the flame control. The diagnostic code indicates the input in which the problem arose
<b>106 ÷ 108</b>	<b>#</b>	<b>Contact request internal error</b>	Carry out a reset; if the error arises repeatedly, replace the flame control

Error code	Diagnostic code	Meaning of the LMV 26... system	Recommended measures
110	#	Voltage monitoring test internal error	Carry out a reset; if the error arises repeatedly, replace the flame control
111	0	Low level of power supply	Insufficient mains voltage. Conversion of the diagnostic code Voltage value (230 V AC: 1.683)
112	0	Reset power supply voltage	Error code for the carrying out of a reset in the event of power supply restoration (absence of error)
113	#	Mains voltage supervision internal error	Carry out a reset; if the error arises repeatedly, replace the flame control
115	#	Flame control meter internal error	
116	0	Life cycle of the flame control in the critical interval (250,000 Start ups)	The envisaged life cycle of the flame control has been exceeded. Replace it.
117	0	Life cycle of the flame control exceeded	The switch-off threshold has been reached.
120	0	Interruption of fuel limiting meter input	Too many disturbance impulses on the input of the fuel meter. Improve the electromagnetic compatibility.
121 ÷ 124	#	EEPROM access internal error	Carry out a reset, repeat and check the last setting of the parameters. Restore the group of parameters: if the error arises repeatedly, replace the flame control.
125	#	EEPROM reading access internal error	Carry out a reset, repeat and check the last setting of the parameters. If the error arises repeatedly, replace the flame control.
126	#	EEPROM writing access internal error	Carry out a reset, repeat and check the last setting of the parameters. If the error arises repeatedly, replace the flame control.
127	#	EEPROM access internal error	Carry out a reset, repeat and check the last setting of the parameters. Restore the group of parameters: if the error arises repeatedly, replace the flame control.
128	0	EEPROM access internal error - synchronisation during the initialisation	Carry out a reset; If the error arises repeatedly, replace the flame control.
129	#	EEPROM access internal error – command synchronisation	Carry out a reset, repeat and check the last setting of the parameters. If the error arises repeatedly, replace the flame control.
130	#	EEPROM access internal error - time-out	Carry out a reset, repeat and check the last setting of the parameters. If the error arises repeatedly, replace the flame control.
131	#	EEPROM access internal error - page interrupted	Carry out a reset, repeat and check the last setting of the parameters. If the error arises repeatedly, replace the flame control.
132	#	EEPROM register initialisation internal error	Carry out a reset; if the error arises repeatedly, replace the flame control.
133 ÷ 135	#	EEPROM access internal error – request synchronisation	Carry out a reset, repeat and check the last setting of the parameters. If the error arises repeatedly, replace the flame control.
136	1	Restoration started	The restoration of a backup has been started (no error)
137	#	Internal error – backup / restoration	
	157 (-99)	Restoration – OK, but backup < compared with set data of current system	Restoration successful, but the backup data installed are fewer than those currently present in the system.
	239 (-17)	Backup - logging of the backup on RDI21... failed	Perform the reset and repeat backup
	240 (-16)	Reset - no backup in RDI21...	No backup in RDI21...
	241 (-15)	Reset - Interruptions relating to impracticable ASN	The backup has an impracticable ASN and cannot reset the unit
	242 (-14)	Backup – the backup carried out is contradictory	The backup is irregular and cannot be transferred again
	243 (-13)	Backup – the data comparison between the internal microprocessors is irregular	Repeat the reset and backup
	244 (-12)	The backup data are incompatible	The backup data are incompatible with the current version of the software; the restoration is not possible
	245 (-11)	Error in access to the parameter Restore_Complete	Repeat the reset and backup
	246 (-10)	Restoration – time-out during logging in EEPROM	Repeat the reset and backup
	247 (-9)	The data received are contradictory	The series of backup data is not valid; restoration is not possible
	248 (-8)	The restoration cannot currently be carried out	Repeat the reset and backup
	249 (-7)	Restoration – interruption caused by inadequate identification of the burner	The backup has an inadequate identification of the burner and must not be transferred to the flame control
	250 (-6)	Backup – the CRC of a page is not correct	The series of backup data is not valid; restoration is not possible
	251 (-5)	Backup – the identification of the burner is not defined	Define the identification of the burner and repeat the backup

Error code	Diagnostic code	Meaning of the LMV 26... system	Recommended measures
	252 (-4)	After restoration, the pages are still in INTERRUPTION	Repeat the reset and backup
	253 (-3)	The restoration cannot currently be carried out	Repeat the reset and backup
	254 (-2)	Interruption owing to transmission error	Repeat the reset and backup
	255 (-1)	Interruption owing to time-out during the restoration	Carry out a reset, check the connections and repeat the backup
<b>146</b>	<b>#</b>	<b>Time-out of the system automation interface</b>	Refer to the Modbus User Documentation (A7541)
	1	Modbus time-out	
<b>150</b>	<b>#</b>	<b>TÜV test</b>	
	1 (-1)	Invalid phase	The TÜV test can only be started in phase 60 (operation)
	2 (-2)	The TÜV test default output is too low	The output of the TÜV test must be lower than the minor output limit
	3 (-3)	The TÜV test default output is too high	The output of the TÜV test must be greater than the upper output limit
	4 (-4)	Manual interruption	No error: Manual interruption of the TÜV test by the user
	5 (-5)	TÜV test time-out	No flame loss after the fuel valves have been closed 1. Check for any extraneous lights 2. Check that there are no short-circuits 3. Check whether one of the valves is leaking
<b>165</b>	<b>#</b>	<b>Internal error</b>	
<b>166</b>	<b>0</b>	<b>Watchdog reset internal error</b>	
<b>167</b>	<b>#</b>	<b>Manual lockout</b>	The flame control has been manually blocked (no error)
	1	Manual lockout from remote reset command	
	2	Manual lockout from RDI21...	
	3	Manual lockout from PC interface	
	8	Manual lockout from RDI21... Timeout/interrupted communication	During a regulation of the curve via the operating panel RDI21...the timeout for the operating menu is passed (setting via the 127 parameter), or else the communication between LMV 26... and RDI21... has been interrupted
	9	Manual lockout from PC interface Communication interrupted	During an adjustment of the curve via the PC interface, the communication between LMV 26... and the operator panel has been interrupted for more than 30 seconds
	33	Manual lockout after the PC tool has performed a tentative reset	The PC tool has performed a tentative reset, even if the system has worked correctly
<b>168 ÷ 171</b>	<b>#</b>	<b>Internal error management</b>	Carry out a reset; if the error arises repeatedly, replace the flame control
<b>200 off</b>	<b>#</b>	<b>System free of errors</b>	No error
<b>201 off VA</b>	<b>#</b>	<b>Lockout or error at start</b>	Lockout or error due to lack of unit parameter settings
	Bit 0 Valency 1	No valid operation mode	
	Bit 1 Valency 2..3	No fuel train defined	
	Bit 2 Valency 4..7	No curve defined	
	Bit 3 Valency 8..15	Standardisation speed not defined	
	Bit 4 Valency 16..31	Backup / Reset impossible	
<b>202</b>	<b>#</b>	<b>Selection of internal operation mode</b>	Redefine the operation mode (parameter 201)
<b>203</b>	<b>#</b>	<b>Internal error</b>	Redefine the operation mode (parameter 201) Carry out a reset; if the error arises repeatedly, replace the flame control
<b>204</b>	<b>Phase number</b>	<b>Program stop</b>	The program stop is active (no error)
<b>205</b>	<b>#</b>	<b>Internal error</b>	Carry out a reset; if the error arises repeatedly, replace the flame control
<b>206</b>	<b>0</b>	<b>Combination of flame control and operator panel not allowed</b>	
<b>207</b>	<b>#</b>	<b>Compatibility of flame control with operator panel</b>	
	0	Obsolete version of flame control	
	1	Obsolete version of operator panel	
<b>208 - 209</b>	<b>#</b>	<b>Internal error</b>	Carry out a reset; if the error arises repeatedly, replace the flame control
<b>210</b>	<b>0</b>	The selected operating mode is not released for the standard unit	Select an operating mode released for the standard unit

Error code	Diagnostic code	Meaning of the LMV 26... system	Recommended measures
240	#	Internal error	Carry out a reset; if the error arises repeatedly, replace the flame control
245	#	Internal error	Carry out a reset; if the error arises repeatedly, replace the flame control
250	#	Internal error	Carry out a reset; if the error arises repeatedly, replace the flame control

Tab. Y

**A Appendix - Accessories**
**Output power regulator kit for modulating operation**

With the modulating operation, the burner continually adapts the power to the heat request, ensuring a high level of stability for the parameter controlled: temperature or pressure.

Two components should be ordered:

- the output power regulator to be installed on the burner;
- the probe to install on the heat generator.

Parameter to be checked		Probe		Output regulator	
	Adjustment field	Type	Code	Type	Code
Temperature	- 100...+ 500°C	PT 100	3010110	RWF50	20099869
Pressure	0...2.5 bar	Output probe 4...20mA	3010213	RWF55	20099905
	0...16 bar		3010214		

**EMI and ferrite filter kit**

Burner	Code
RLS 68-120/E MX	20122917

**Continuous purging kit**

Burner	Code
RLS 68-120/E MX	3010094

**Soundproofing box kit**

Burner	Code
RLS 68-120/E MX	3010404

**Tubes kit**

Burner	Code
RLS 68/E MX	20006401
RLS 120/E MX	20006402

**Software interface kit (ACS410 + OCI410.30) - Service Level**

Burner	Code
RLS 68-120/E MX	3010436

**Modbus interface kit**

Burner	Model	Code
RLS 68-120/E MX	OCI412	3010437

**Gas trains in compliance with EN 676**

Please refer to manual.

**B Appendix - Electrical panel layout**

<b>1</b>	<b>Index of layouts</b>
<b>2</b>	Indication of references
<b>3</b>	Layout of unifilar output
<b>4</b>	LMV26.... operational layout
<b>5</b>	LMV26.... operational layout
<b>6</b>	LMV26.... operational layout
<b>7</b>	LMV26.... operational layout
<b>8</b>	LMV26.... operational layout
<b>9</b>	Electrical connections set by installer
<b>10</b>	Electrical connections set by installer
<b>11</b>	RWF50.... operational layout

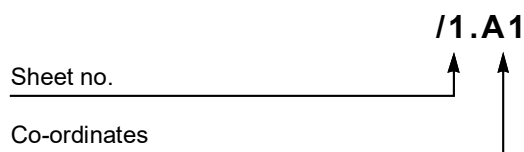
**2 Indication of references**

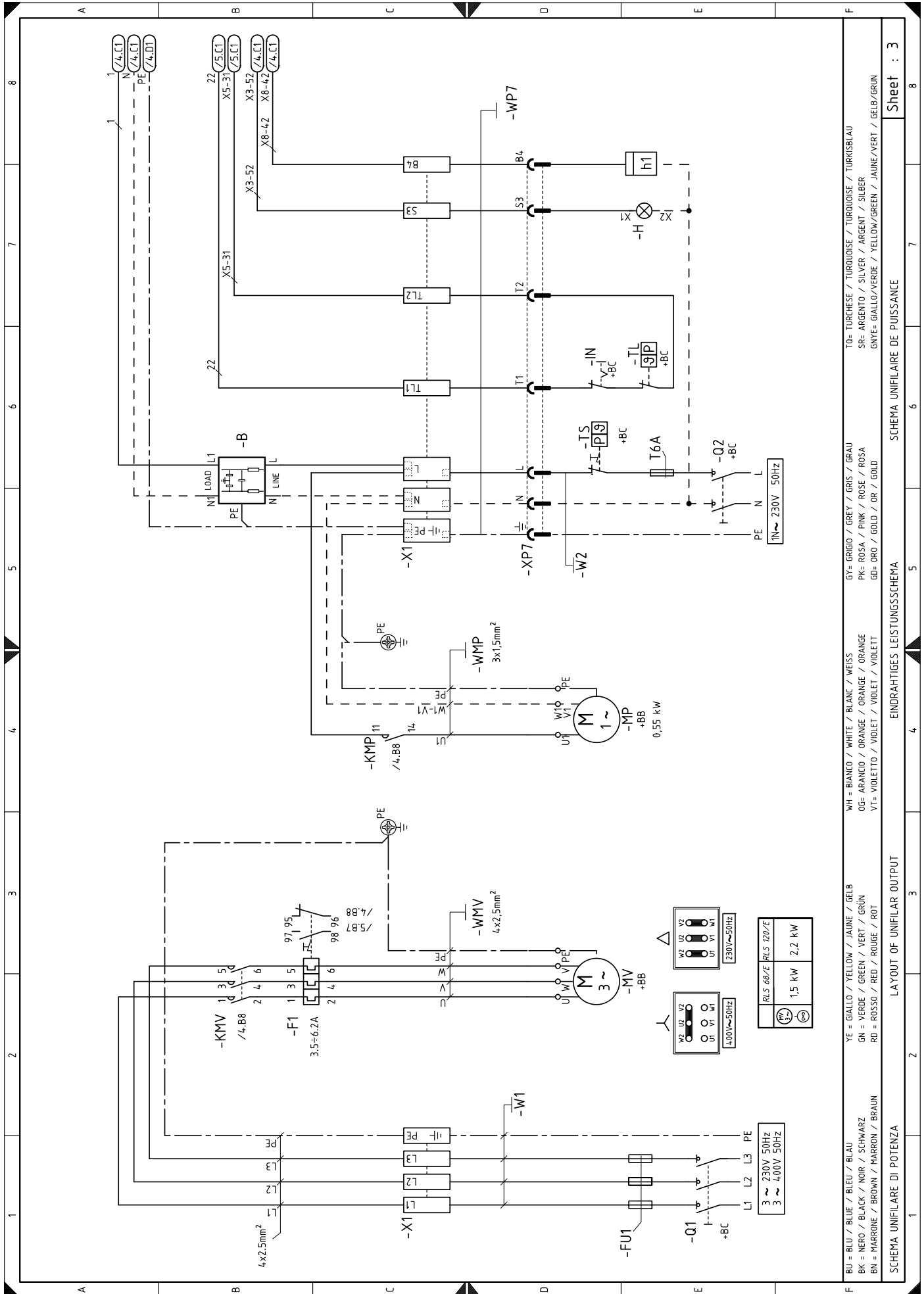

TO= TURCHÈSE / TURQUOISE / TURKOISE / TURKISBLAU	GY= GRIGIO / GREY / GRIS / GRAU	WH = BIANCO / WHITE / BLANC / WEISS	YE = GIALLO / YELLOW / JAUNE / GELB	BU = BLU / BLUE / BLEU / BLAU
SR= ARGENTO / SILVER / ARGENT / SILBER	PK= ROSA / PINK / ROSE / ROSA	OG= ARANCIO / ORANGE / ORANGE / ORANGE	GN = VERDE / GREEN / VERT / GRÜN	BK = NERO / BLACK / NOIR / SCHWARZ
GRYE= GIALLO/VERDE / YELLOW/GREEN / JAUNE/VERT / GELB/GRÜN	GD= ORO / GOLD / OR / GOLD	VT= VIOLETT / VIOLET / VIOLET / VIOLETT	RD = ROSSO / RED / ROUGE / ROT	BN = MARRONE / BROWN / MARRON / BRAUN

Sheet : 3

SCHEMA UNIFILAIRE DE PUISSANCE

EINDRAHTIGES LEISTUNGSSCHEMA

LAYOUT OF UNIFILAR OUTPUT

SCHEMA UNIFILARE DI POTENZA





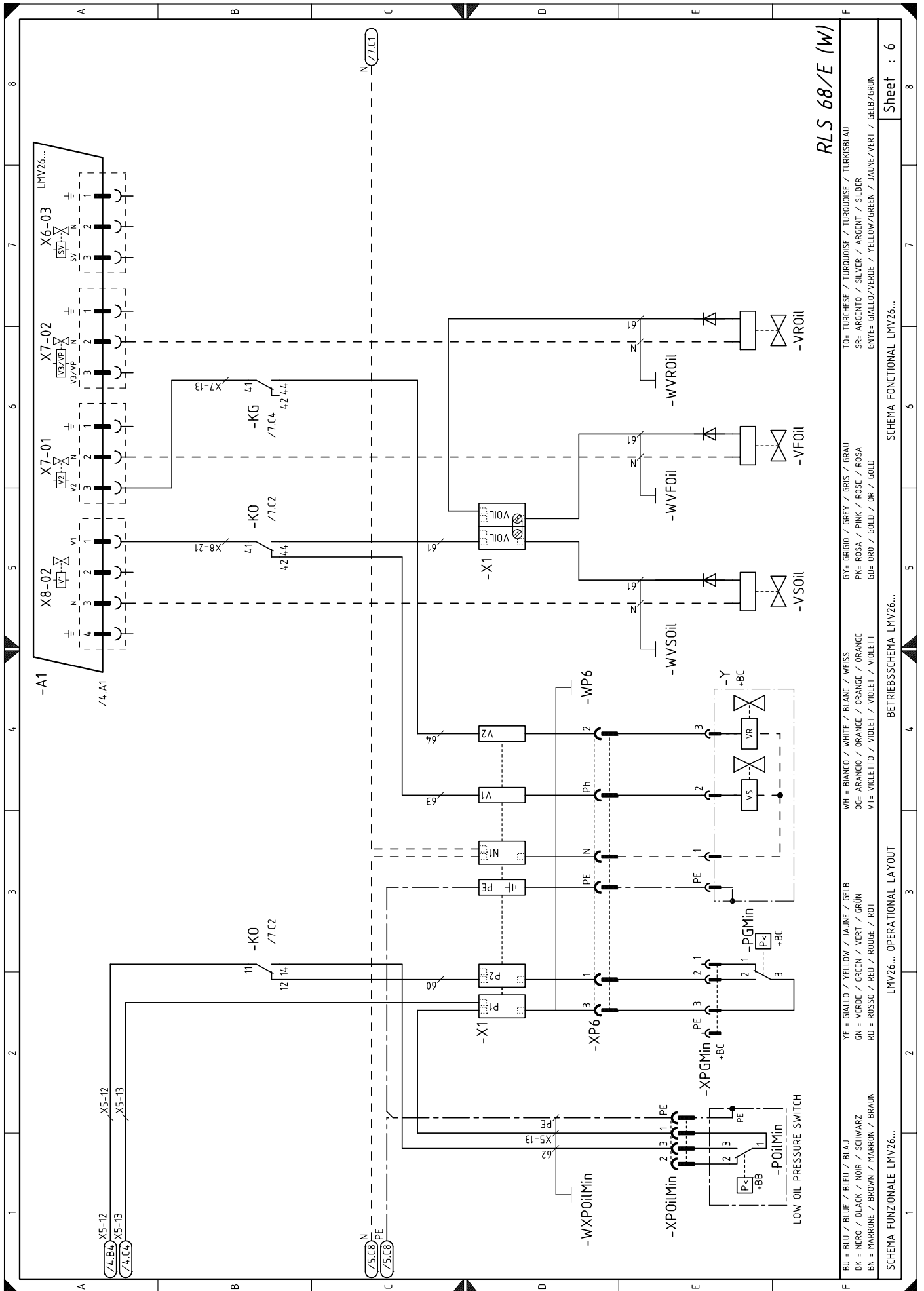

RLS 68/E (W)

TO= TURCHESE / TURQUOISE / TURQUOISE / TURKSBLAU  
 SR= ARGENTO / SILVER / ARGENT / SILBER  
 GNYE= GIALLO/VERDE / YELLOW/GREEN / JAUNE/VERT / GELB/GRUN  
 GY= GRIGIO / GREY / GRIS / GRAU  
 PK= ROSA / PINK / ROSE / ROSA  
 GD= ORO / GOLD / OR / GOLD  
 WH= BIANCO / WHITE / BLANC / WEISS  
 OG= ARANCIO / ORANGE / ORANGE / ORANGE  
 VT= VIOLETTO / VIOLET / VIOLET / VIOLETT  
 YE= GIALLO / YELLOW / JAUNE / GELB  
 GN= VERDE / GREEN / VERT / GRUN  
 RD= ROSSO / RED / ROUGE / ROT  
 BU= BLU / BLUE / BLEU / BLAU  
 BK= NERO / BLACK / NOIR / SCHWARZ  
 BN= MARRONE / BROWN / MARRON / BRAUN

SCHEMA FUNZIONALE LMV26... SCHEMA FONCTIONAL LMV26... SCHEMA FUNZIONALE LMV26... SCHEMA FONCTIONAL LMV26...

Sheet : 6

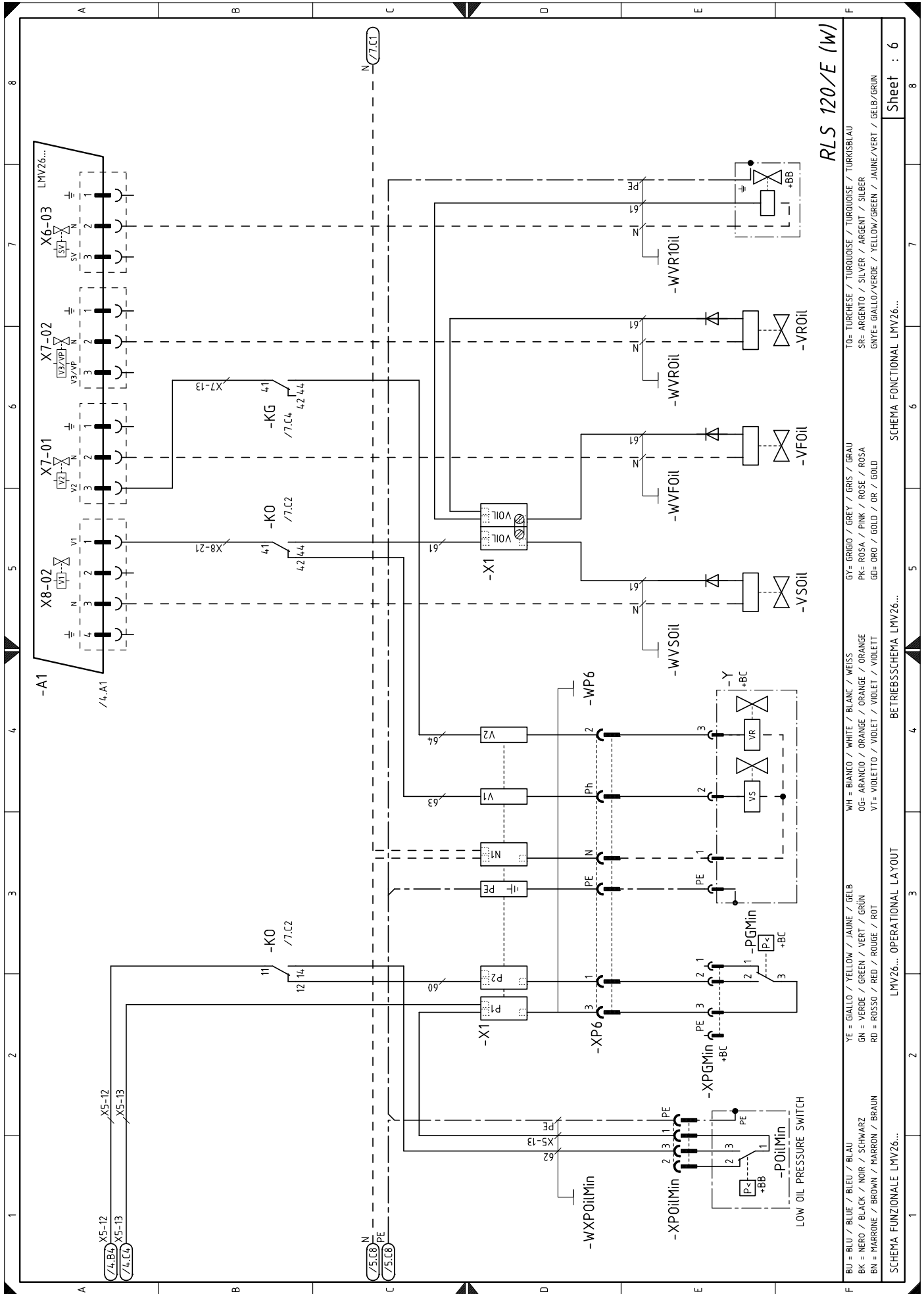

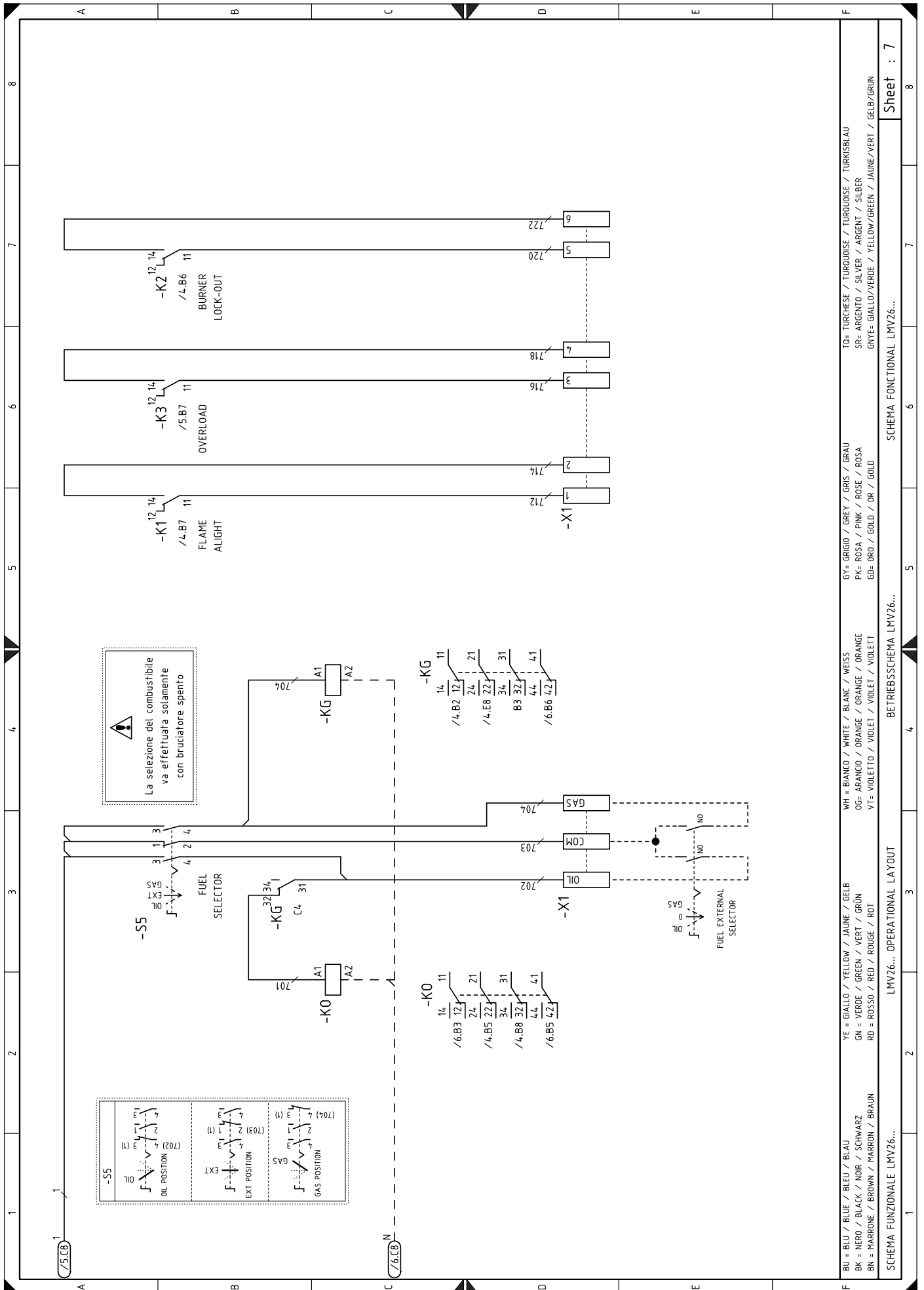

La selezione del combustibile va effettuata solamente con bruciatore spento

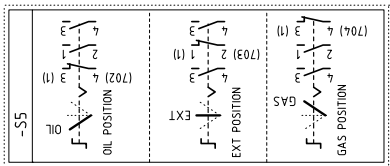

TO= TURCHESE / TURQUOISE / TURKISBLAU  
 SR= ARGENTO / SILVER / ARGENT / SILBER  
 GNYE= GIALLO/VERDE / YELLOW/GREEN / JAUNE/VERT / GELB/GRUN

GY= GRIGIO / GREY / GRIS / GRAU  
 PK= ROSA / PINK / ROSE / ROSA  
 GD= ORO / GOLD / OR / GOLD

WH = BIANCO / WHITE / BLANC / WEISS  
 OG= ARANCIO / ORANGE / ORANGE / ORANGE  
 VT= VIOLETTO / VIOLET / VIOLET / VIOLETT

YE = GIALLO / YELLOW / JAUNE / GELB  
 GN = VERDE / GREEN / VERT / GRUN  
 RD = ROSSO / RED / ROUGE / ROT

BU = BLU / BLUE / BLEU / BLAU  
 BK = NERO / BLACK / NOIR / SCHWARZ  
 BN = MARRONE / BROWN / MARRON / BRAUN

SCHEMA FUNZIONALE LMV26...  
 SCHEMA FUNCTIONAL LMV26...  
 BETRIEBSSCHEMA LMV26...  
 LMV26... OPERATIONAL LAYOUT

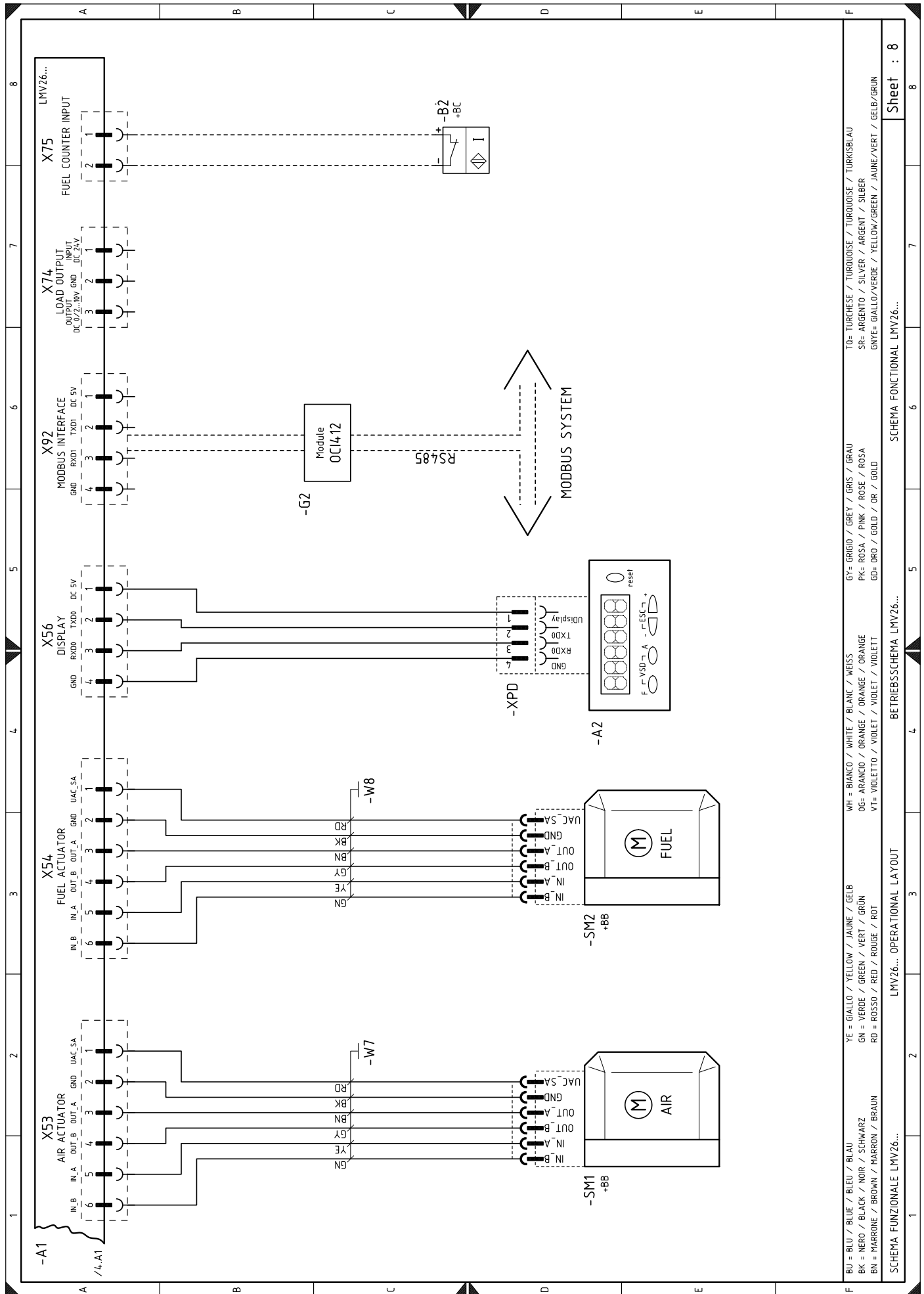

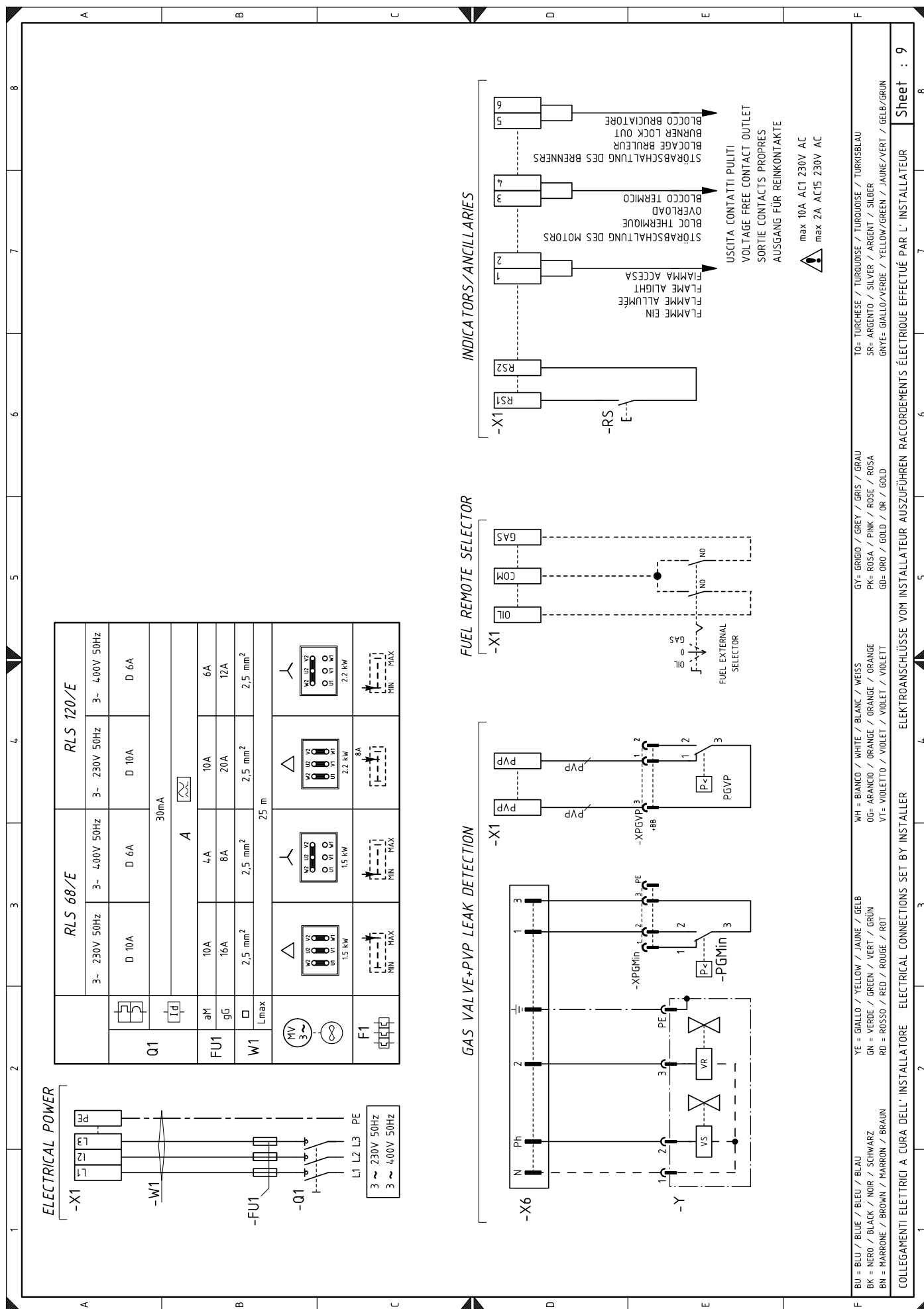





**Wiring layout key**

+BB	Burner components	TA	Ignition transformer
+BC	Boiler components	TL	Limit thermostat/pressure switch
A1	Flame control	TR	Adjustment thermostat/pressure switch
A2	Operator panel	TS	Safety thermostat/pressure switch
B	Filter to protect against radio disturbance	VFOil	Light oil working valve
B1	Output regulator RWF50	VROil	Light oil adjustment valve
B2	Fuel meter	VR1Oil	Light oil adjustment valve
BA	Input in current DC 4...20 mA	VSOil	Oil safety valve
BA1	Input in current DC 4...20 mA to modify remote setpoint	X1	Burner terminal strip
BP	Pressure probe	X4	4-pin plug
BP1	Pressure probe	X6	6-pin plug
BR	Remote setpoint potentiometer	X7	7-pin plug
BT1	Thermocouple probe	XP1	Connector for output power regulator kit RWF50
BT2	Probe Pt100, 2 wires	XP4	4-pole socket
BT3	Probe Pt100, 3 wires	XP6	6-pole socket
BT4	Probe Pt100, 3 wires	XP7	7-pole socket
BTEXT	External probe for climatic compensation of the setpoint	XPD	Operator panel connector
BV	Input in voltage DC 0...10V	XPGM	Maximum gas pressure switch connector
BV1	Input in voltage DC 0...10V to modify remote setpoint	XPGMin	Minimum gas pressure switch connector
F1	Fan motor thermal relay	XPGVP	Gas pressure switch connector for gas leak control
F2	Pump motor thermal relay	XPOilMax	Maximum oil pressure switch connector
FU1	Three-phase power supply fuses	XPOilMin	Minimum oil pressure switch connector
H	Remote lockout signal	Y	Gas regulator valve + gas safety valve
h1	Operation hour counter		
IN	Burner manual stop switch		
K1	Relay "K1" (clean contacts "FLAME ALIGHT")		
K2	Relay "K2" (clean contacts "BURNER LOCK-OUT")		
K3	Relay "K3" (clean contacts "OVERLOAD" fan motor)		
KG	Gas operation "KG" relay		
KMP	Pump motor contact maker		
KMV	Fan motor contact maker		
KO	Light oil operation "KO" relay		
MP	Pump motor		
MV	Fan motor		
OCI	Communication interface for Modbus system		
PA	Air pressure switch		
PE	Burner earth		
PGM	Maximum gas pressure switch		
PGMin	Minimum gas pressure switch		
PGVP	Gas pressure switch for valve leak detection control device		
POilMin	Minimum oil pressure switch		
POilMax	Maximum oil pressure switch		
Q1	Three-phase line disconnecting switch		
Q2	Single-phase line disconnecting switch		
QRA	Flame sensor		
RS	Remote burner reset button		
S1	On/off selector		
S5	Fuel selector		
SM1	Air servomotor		
SM2	Gas servomotor		



---

**RIELLO**

RIELLO S.p.A.  
I-37045 Legnago (VR)  
Tel.: +39.0442.630111  
[http:// www.riello.it](http://www.riello.it)  
[http:// www.riello.com](http://www.riello.com)