

**GB** **Dual fuel light oil/gas burners**

Modulating operation

**CE**

**UK  
CA**

**EAC**

CODE	MODEL	TYPE
20080869	RLS 1600/EV C11	LS003T2
20066055	RLS 2000/EV C11	1316 T2



**Translation of the original instructions**

<b>1</b>	<b>Information and general warnings.....</b>	<b>3</b>
1.1	Information about the instruction manual .....	3
1.1.1	Introduction.....	3
1.1.2	General dangers.....	3
1.1.3	Other symbols .....	3
1.1.4	Delivery of the system and the instruction manual .....	4
1.2	Guarantee and responsibility.....	4
<b>2</b>	<b>Safety and prevention.....</b>	<b>5</b>
2.1	Introduction.....	5
2.2	Personnel training .....	5
<b>3</b>	<b>Technical description of the burner .....</b>	<b>6</b>
3.1	Burner designation .....	6
3.2	Models available.....	6
3.3	Burner categories - Countries of destination .....	6
3.4	Technical data .....	7
3.5	Electrical data.....	7
3.6	Maximum dimensions.....	8
3.7	Firing rates .....	9
3.8	Test boiler.....	10
3.9	Burner description .....	11
3.10	Electrical panel description.....	12
3.11	Burner equipment.....	12
3.12	AZL Display.....	13
3.13	Flame control (LMV52.....)	14
3.14	Servomotor (SQM48.4.....)	16
<b>4</b>	<b>Installation .....</b>	<b>17</b>
4.1	Notes on safety for the installation .....	17
4.2	Handling .....	17
4.3	Preliminary checks .....	17
4.4	Operating position .....	18
4.5	Removing the shutter lockout screws.....	18
4.6	Coupling of the burner - Centre of gravity position .....	18
4.7	Preparing the boiler .....	19
4.7.1	Boring the boiler plate .....	19
4.7.2	Blast tube length.....	19
4.8	Securing the burner to the boiler .....	19
4.9	Access to head internal part.....	20
4.10	Nozzle installation .....	21
4.10.1	Recommended nozzle.....	21
4.11	Electrode position.....	21
4.12	Combustion head adjustment.....	22
4.13	Light oil supply.....	22
4.13.1	Double-pipe circuit.....	22
4.13.2	Hydraulic connections .....	23
4.13.3	Hydraulic circuit diagram .....	23
4.13.4	Pressure variator .....	23
4.14	Gas feeding .....	24
4.14.1	Gas feeding line (Example) - Please refer to the gas train documentation for more information.....	24
4.14.2	Gas train.....	25
4.14.3	Gas train installation.....	25
4.14.4	Gas pressure .....	25
4.14.5	Pilot - gas train connection.....	26
4.14.6	Ignition pilot burner.....	26
4.15	Electrical wiring .....	27

4.15.1	Notes on terminals .....	27
4.15.2	Supply cables and external connections passage .....	28
4.15.3	Shielding the connections .....	29
4.16	Motor rotation .....	29
4.17	Calibration of the thermal relay .....	30
<b>5</b>	<b>Start-up, calibration and operation of the burner .....</b>	<b>31</b>
5.1	Notes on safety for the first start-up .....	31
5.2	Adjustments prior to ignition (light oil) .....	31
5.2.1	Nozzle .....	31
5.2.2	Combustion head .....	31
5.3	Burner ignition (light oil) .....	31
5.4	Adjustments prior to ignition (gas) .....	32
5.5	Burner start-up (gas) .....	32
5.6	Burner ignition .....	32
5.7	Change of fuel .....	32
5.8	Combustion air adjustment .....	33
5.8.1	Air / gas adjustment and output modulation .....	33
5.9	Pressure switch adjustment .....	34
5.9.1	Air pressure switch - check CO .....	34
5.9.2	Maximum gas pressure switch .....	34
5.9.3	Minimum gas pressure switch .....	34
5.9.4	PVP pressure switch kit .....	35
5.9.5	Oil pressure switch .....	35
5.10	Final checks (with burner operating) .....	35
<b>6</b>	<b>Maintenance .....</b>	<b>36</b>
6.1	Notes on safety for the maintenance .....	36
6.2	Maintenance programme .....	36
6.2.1	Maintenance frequency .....	36
6.2.2	Safety test - with no gas supply .....	36
6.2.3	Checking and cleaning .....	36
6.2.4	Electrical panel .....	38
6.3	Checking the position of the rpm sensor .....	39
6.3.1	Safety components .....	40
6.3.2	Pump unit .....	40
6.4	Opening the burner .....	41
6.5	Closing the burner .....	41
<b>7</b>	<b>Faults - Probable causes - Solutions .....</b>	<b>42</b>
<b>A</b>	<b>Appendix - Accessories .....</b>	<b>43</b>
<b>B</b>	<b>Appendix - Electrical panel layout .....</b>	<b>44</b>

**1 Information and general warnings**

**1.1 Information about the instruction manual**

**1.1.1 Introduction**

The instruction manual supplied with the burner:

- is an integral and essential part of the product and must not be separated from it; it must therefore be kept carefully for any necessary consultation and must accompany the burner even if it is transferred to another owner or user, or to another system. If the manual is lost or damaged, another copy must be requested from the Technical Assistance Service of the area;
- is designed for use by qualified personnel;
- offers important indications and instructions relating to the installation safety, start-up, use and maintenance of the burner.

**Symbols used in the manual**

In some parts of the manual you will see triangular DANGER signs. Pay great attention to these, as they indicate a situation of potential danger.

**1.1.2 General dangers**

The **dangers** can be of **3 levels**, as indicated below.



Maximum danger level!  
This symbol indicates operations which, if not carried out correctly, cause serious injury, death or long-term health risks.



This symbol indicates operations which, if not carried out correctly, may cause serious injury, death or long-term health risks.



This symbol indicates operations which, if not carried out correctly, may cause damage to the machine and/or injury to people.

**1.1.3 Other symbols**



**DANGER: LIVE COMPONENTS**  
This symbol indicates operations which, if not carried out correctly, lead to electric shocks with lethal consequences.



**DANGER: FLAMMABLE MATERIAL**  
This symbol indicates the presence of flammable materials.



**DANGER: BURNING**  
This symbol indicates the risks of burns due to high temperatures.



**DANGER: CRUSHING OF LIMBS**  
This symbol indicates the presence of moving parts: danger of crushing of limbs.



**WARNING: MOVING PARTS**

This symbol indicates that you must keep limbs away from moving mechanical parts; danger of crushing.



**DANGER: EXPLOSION**

This symbol signals places where an explosive atmosphere may be present. An explosive atmosphere is defined as a mixture - under atmospheric conditions - of air and flammable substances in the form of gases, vapours, mist or dust in which, after ignition has occurred, combustion spreads to the entire unburned mixture.



**PERSONAL PROTECTION EQUIPMENT**

These symbols indicate the equipment that must be worn and kept by the operator for protection against threats against safety and/or health while at work.



**OBLIGATION TO ASSEMBLE THE COVER AND ALL THE SAFETY AND PROTECTION DEVICES**

This symbol signals the obligation to reassemble the cover and all the safety and protection devices of the burner after any maintenance, cleaning or checking operations.



**ENVIRONMENTAL PROTECTION**

This symbol gives indications for the use of the machine with respect for the environment.



**IMPORTANT INFORMATION**

This symbol indicates important information that you must bear in mind.



This symbol indicates a list.

**Abbreviations used**

Ch.	Chapter
Fig.	Figure
Page	Page
Sec.	Section
Tab.	Table

**1.1.4 Delivery of the system and the instruction manual**

When the system is delivered, it is important that:

- the instruction manual is delivered to the user by the system manufacturer, with the recommendation to keep it in the room where the heat generator is to be installed.
- The instruction manual shows:
  - the serial number of the burner;

.....

- the address and telephone number of the nearest Assistance Centre

.....  
 .....  
 .....

- The system supplier must carefully inform the user about:
  - the use of the system;
  - any further tests that may be required before activating the system;
  - maintenance, and the need to have the system checked at least once a year by a representative of the manufacturer or another specialised technician. To ensure a periodic check, the manufacturer recommends the drawing up of a Maintenance Contract.

**1.2 Guarantee and responsibility**

The manufacturer guarantees its new products from the date of installation, in accordance with the regulations in force and/or the sales contract. At the moment of the first start-up, check that the burner is integral and complete.



**WARNING**

Failure to observe the information given in this manual, operating negligence, incorrect installation and carrying out of non authorised modifications will result in the annulment by the manufacturer of the guarantee that it supplies with the burner.

In particular, the rights to the guarantee and the responsibility will no longer be valid, in the event of damage to things or injury to people, if such damage/injury was due to any of the following causes:

- incorrect installation, start-up, use and maintenance of the burner;
- improper, incorrect or unreasonable use of the burner;
- intervention of unqualified personnel;
- carrying out of unauthorised modifications on the equipment;
- use of the burner with safety devices that are faulty, incorrectly applied and/or not working;
- installation of untested supplementary components on the burner;
- powering of the burner with unsuitable fuels;
- faults in the fuel supply system;
- continuation of use of the burner when a fault has occurred;
- repairs and/or overhauls incorrectly carried out;
- modification of the combustion chamber with inserts that prevent the regular development of the structurally established flame;
- insufficient and inappropriate surveillance and care of those burner components most likely to be subject to wear and tear;
- use of non-original components, including spare parts, kits, accessories and optional;
- force majeure.

**The manufacturer furthermore declines any and every responsibility for the failure to observe the contents of this manual.**

**2 Safety and prevention**

**2.1 Introduction**

The burners have been designed and built in compliance with current regulations and directives, applying the known technical rules of safety and envisaging all the potential danger situations. It is necessary, however, to bear in mind that the imprudent and clumsy use of the equipment may lead to situations of death risk for the user or third parties, as well as the damaging of the burner or other items. Inattention, thoughtlessness and excessive confidence often cause accidents; the same applies to tiredness and sleepiness.

It is a good idea to remember the following:

- The burner must only be used as expressly described. Any other use should be considered improper and therefore dangerous.

In particular:

it can be applied to boilers operating with water, steam, diathermic oil, and to other uses expressly foreseen by the manufacturer;

the type and pressure of the fuel, the voltage and frequency of the electrical power supply, the minimum and maximum deliveries for which the burner has been regulated, the pressurisation of the combustion chamber, the dimensions of the combustion chamber and the ambient temperature must all be within the values indicated in the instruction manual.

- Modification of the burner to alter its performance and destinations is not allowed.
- The burner must be used in exemplary technical safety conditions. Any disturbances that could compromise safety must be quickly eliminated.
- Opening or tampering with the burner components is not allowed, apart from the parts requiring maintenance.
- Only those parts envisaged by the manufacturer can be replaced.



The manufacturer guarantees safety and proper functioning only if all burner components are intact and positioned correctly.

**2.2 Personnel training**

The user is the person, body or company that has acquired the machine and intends to use it for the specific purpose. He is responsible for the machine and for the training of the people working around it.

The user:

- undertakes to entrust the machine exclusively to suitably trained and qualified personnel;
- undertakes to inform his personnel in a suitable way about the application and observance of the safety instructions. With that aim, he undertakes to ensure that everyone knows the use and safety instructions for his own duties;
- Personnel must observe all the danger and caution indications shown on the machine.
- Personnel must not carry out, on their own initiative, operations or interventions that are not within their province.
- Personnel must inform their superiors of every problem or dangerous situation that may arise.
- The assembly of parts of other makes, or any modifications, can alter the characteristics of the machine and hence compromise operating safety. The manufacturer therefore declines any and every responsibility for any damage that may be caused by the use of non-original parts.

In addition:



- must take all the measures necessary to prevent unauthorised people gaining access to the machine;
- the user must inform the manufacturer if faults or malfunctioning of the accident prevention systems are noticed, along with any presumed danger situation;
- personnel must always use the personal protective equipment envisaged by legislation and follow the indications given in this manual.

**3 Technical description of the burner**

**3.1 Burner designation**

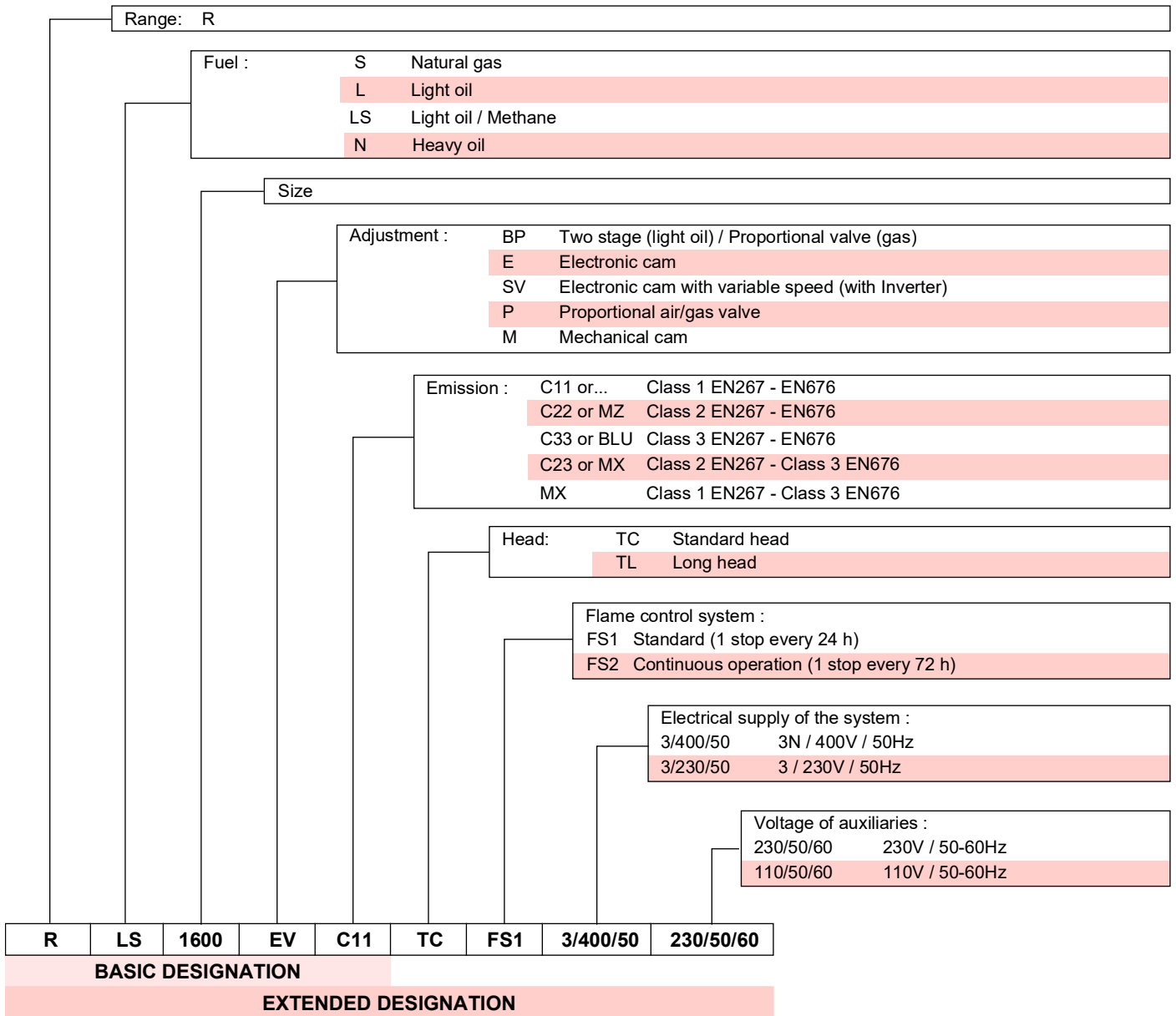

**3.2 Models available**

Designation	TC	Voltage	Start-up	Code
RLS 1600/EV C11	TC	3/400/50	Direct/Inverter	20080869
RLS 2000/EV C11	TC	3/400/50	Direct/Inverter	20066055

**3.3 Burner categories - Countries of destination**

Country of destination	Gas category
AT - BG - CH - CZ - DK - EE - ES - FI - GB - GR - HU - IE - IS - IT - LT - LV - NO - PT - RO - SE - SI - SK - TR	I <sub>2</sub> H
BE	I <sub>2</sub> E(R)
DE	I <sub>2</sub> ELL
LU - PL	I <sub>2</sub> E
NL	I <sub>2</sub> EK
FR	I <sub>2</sub> Er

## 3.4 Technical data

Model				RLS 1600/EV C11	RLS 2000/EV C11
Type				LS003T2	1316 T2
Power (1)	Light oil	min - max	kW	3145/9500 ÷ 15755	2520/11955 ÷ 18500
Power (1)	Natural gas			3070/9500 ÷ 15500	1560/12075 ÷ 18500
Delivery (1)	Light oil		kg/h	267/805 ÷ 1335	214/1013 ÷ 1568
Fuels				- Light oil, max. viscosity at 20 °C: 6 mm <sup>2</sup> /s (1.5°E - 6 cSt) - Natural gas: G20 (methane gas) - G25	
Operation (2)				- Intermittent/Continuous (min. 1 stop every 24/72 hours) - Modulating	
Nozzles			number	1	
Standard applications				Boilers: water, steam, diathermic oil	
Ambient temperature			°C	0 - 50	
Combustion air temperature			°C max	60	
Noise levels (3)	Sound pressure		dB(A)	91	93
	Sound power			102	104
Weight			kg	1000	1050
CE			No.	CE-0476DQ3601	

**Tab. A**

- (1) Reference conditions: Ambient temperature 20°C - Gas temperature 15°C - Barometric pressure 1,013 mbar - Altitude 0 m a.s.l.  
 (2) The burners are factory set for FS1 operation (1 stop every 24 hours), but can be switched to the FS2 operation (continuous - 1 stop every 72 hours) by changing the parameters of the AZL display.  
 (3) Noise emission tests carried out as specified in EN 15036-1 with measurement accuracy  $\delta = \pm 1.5$  dB, in the manufacturer's combustion chamber with burner operating on test boiler at maximum output.

## 3.5 Electrical data

Model				RLS 1600/EV C11	RLS 2000/EV C11
Electrical supply				3N ~ 400V 50 Hz	
Maximum absorbed electrical power	Light oil (*)		kW max	48	55.8
	Gas			41.5	49.3
Protection level				IP 55	

**Tab. B**

(\*) The output is calculated taking into account the use of a 5.5 kW pump motor.

**3.6 Maximum dimensions**

The maximum dimensions of the burner are given in Fig. 1. Bear in mind that inspection of the combustion head requires the burner to be opened and the rear part turned on the hinge.

The maximum dimensions of the open burner are indicated by the L and R positions. The I position is reference for the refractory thickness of the boiler door.

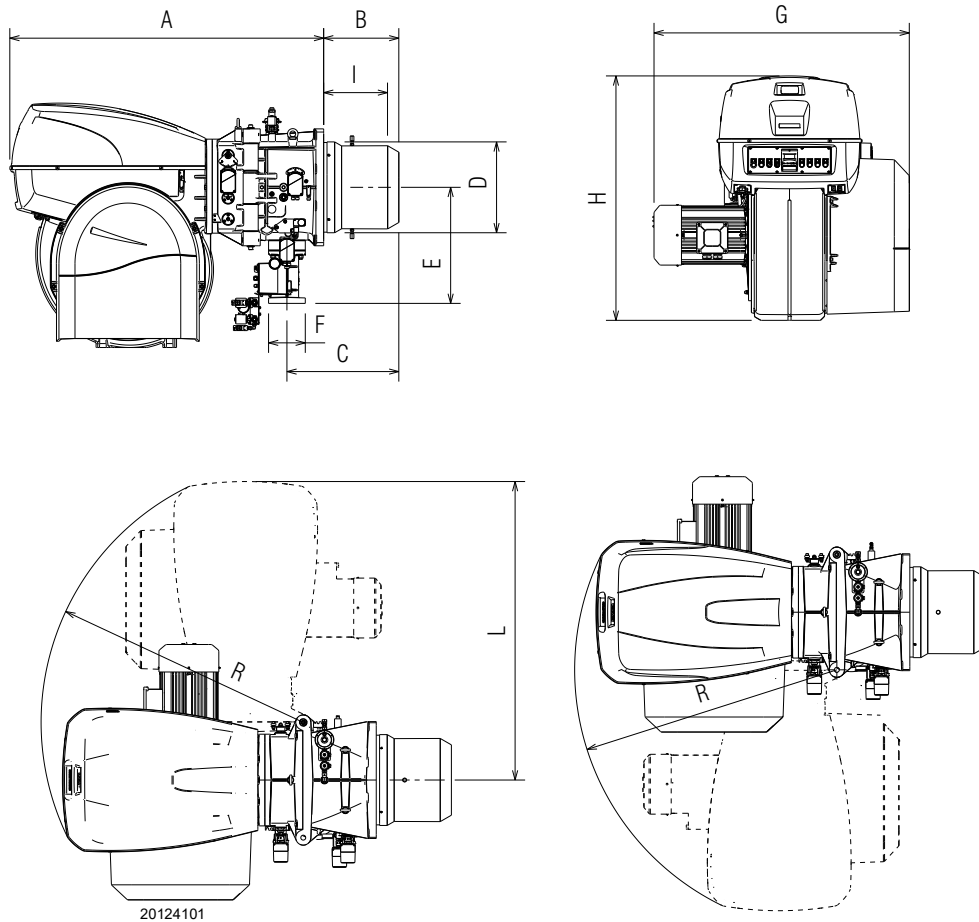

**Fig. 1**

mm	A	B	C	D	E	F	G	H	I	L	R
RLS 1600/EV C11	1880	450	220	544	960	DN100	1560	1464	383	1782	1564
RLS 2000/EV C11	1880	450	220	544	960	DN100	1530	1464	383	1782	1564

**Tab. C**

## 3.7 Firing rates

The **MAXIMUM OUTPUT** is chosen from within the continuous diagram area Fig. 2 and Fig. 3.

The **MINIMUM OUTPUT** must not be lower than the minimum:



The firing rates values (Fig. 2 and Fig. 3) here been obtained considering an ambient temperature of 20 °C, an atmospheric pressure of 1,013 mbar (approx. 0 m a.s.l.), and with the combustion head adjusted as shown on page 22.

Model	Light oil	Natural gas
RLS 1600/EV C11	3145 kW	3070 kW
RLS 2000/EV C11	2520 kW	1560 kW

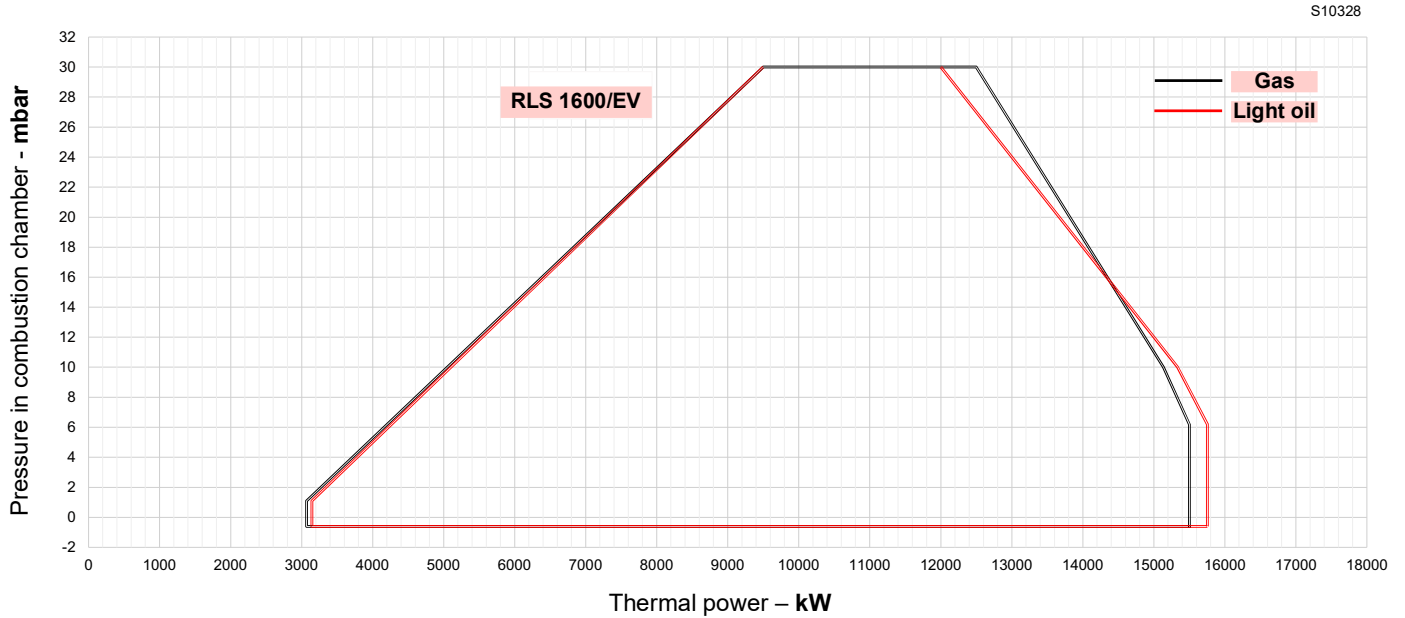

Fig. 2

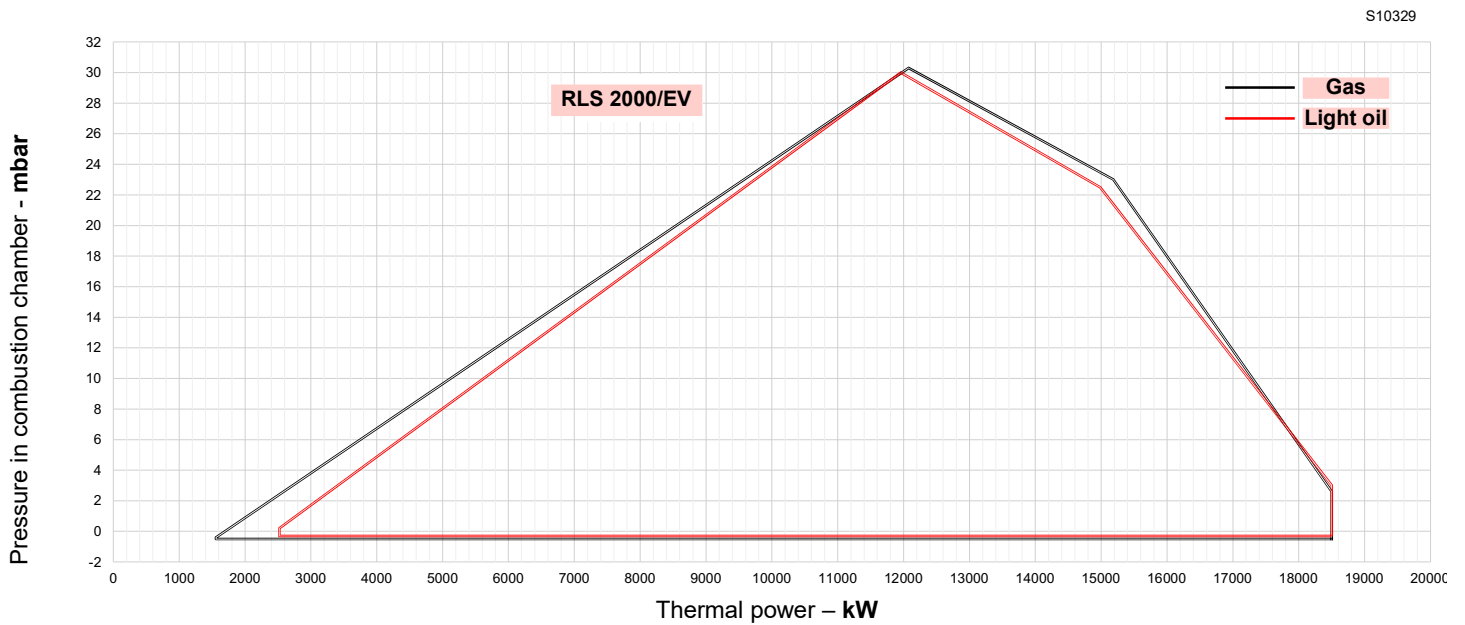

Fig. 3

**3.8 Test boiler**

The burner/boiler combination does not pose any problems if the boiler is EC approved and its combustion chamber dimensions are similar to those indicated in the diagram (Fig. 4).

If the burner must be combined with a boiler that has not been EC approved and/or its combustion chamber dimensions are clearly smaller than those indicated in the diagram, consult the manufacturer. The firing rates were set in relation to special test boilers, according to EN 676 regulations.

In Fig. 4 you can see the diameter and length of the test combustion chamber.

**Example:**

Output 7000 kW - diameter 120 cm - length 6 m

**MODULATING RATIO**

The modulating ratio, obtained in the test boilers, according to standard (EN 676 for gas, EN 267 for light oil), is of 4:1.

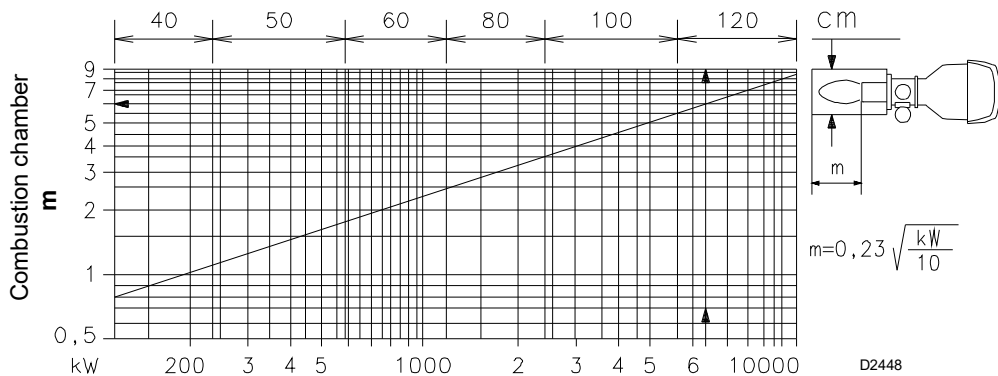

**Fig. 4**

3.9 Burner description

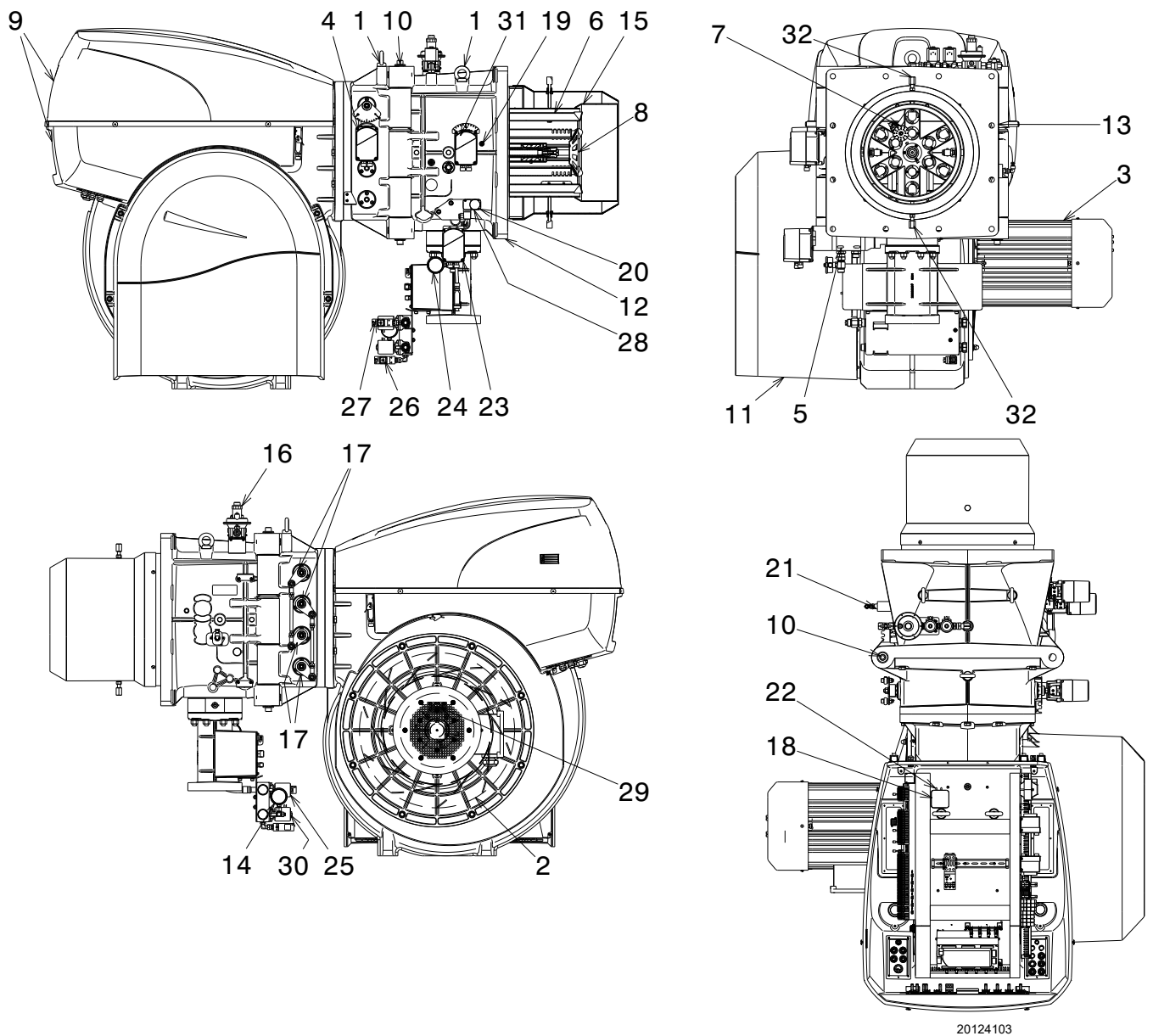

20124103

Fig. 5

- |  |  |
|--|--|
| <ul style="list-style-type: none"> <li>1 Lifting rings</li> <li>2 Fan</li> <li>3 Fan motor</li> <li>4 Air damper servomotor</li> <li>5 Oil modulator</li> <li>6 Combustion head</li> <li>7 Ignition pilot burner</li> <li>8 Flame stability disc</li> <li>9 Electrical panel casing</li> <li>10 Hinge for opening the burner</li> <li>11 Fan air inlet</li> <li>12 Pipe coupling</li> <li>13 Gasket for boiler fixing</li> <li>14 Nozzle return pressure gauge</li> <li>15 Shutter</li> <li>16 Combustion head movement lever</li> <li>17 Air damper movement lever</li> <li>18 Minimum air pressure switch (differential operating type)</li> <li>19 Combustion head air pressure test point</li> <li>20 Maximum gas pressure switch with pressure test point</li> <li>21 QRI flame sensor</li> <li>22 Pressure test point for air pressure switch “+”</li> </ul> | <ul style="list-style-type: none"> <li>23 Gas butterfly valve and oil modulator servomotor</li> <li>24 Delivery pressure gauge</li> <li>25 Oil delivery safety valves</li> <li>26 Maximum oil pressure switch on return</li> <li>27 Minimum oil pressure switch</li> <li>28 Combustion head gas pressure test point</li> <li>29 Rpm probe</li> <li>30 Return oil safety valves</li> <li>31 Shutter position adjustment servomotor</li> <li>32 Screws to lock the shutter during transportation (replace them with the M12x25 screws supplied as standard)</li> </ul> |
|--|--|



CAUTION

The burner can be opened to the right or to the left without links to the fuel supply side.

When the burner is closed, the hinge pin can be refitted on the opposite side.

**3.10 Electrical panel description**

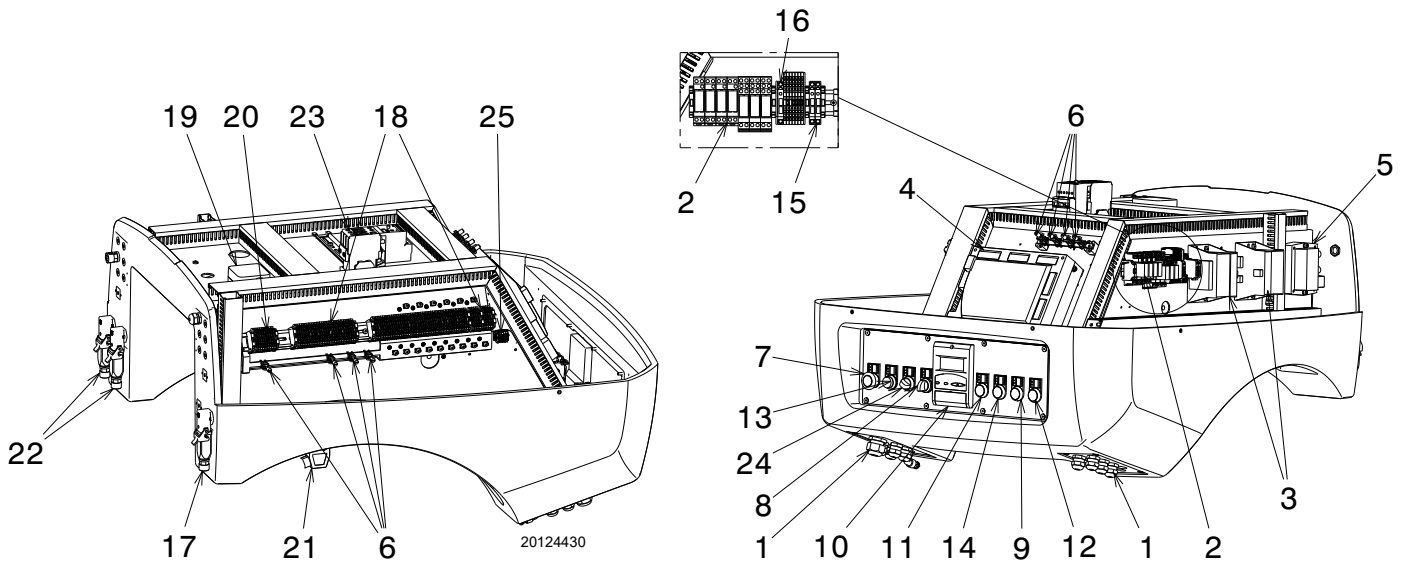

**Fig. 6**

- 1 Supply cables, external connections and kits
- 2 Volt-free contacts output relay
- 3 Electronic cam transformer
- 4 Flame control
- 5 Ignition transformer
- 6 Shielding terminals
- 7 Emergency button
- 8 Fuel selector and enable signal to remote fuel selector
- 9 Light signalling of main fuel valve open
- 10 AZL display
- 11 Voltage present warning lamp
- 12 Light signalling of fan motor lockout and pump motor
- 13 Burner lockout warning lamp and reset switch
- 14 Heat request signal
- 15 Auxiliary transformer fuses
- 16 Auxiliary circuits fuse
- 17 Flame sensor plug/sensor socket
- 18 Main terminal supply board

- 19 Air pressure switch
- 20 Terminal board for O<sub>2</sub> kit
- 21 Plug/Oil valve socket/pump motor (derivation unit)
- 22 Plug/socket servomotor
- 23 Pump motor contactor and thermal relay
- 24 Off-automatic selector
- 25 Rpm sensor terminal board

**NOTE**

Two types of burner failure may occur:

- **flame control lockout:** the switching on of the button (**red led**) 13)(Fig. 6) signals that the burner is in lockout. Release by pressing button 13)(Fig. 6) or use the display.
- **Motor lockout:** release the pump motor by pressing the button on the relevant thermal relay. See the inverter manual for the release of the fan motor.

**3.11 Burner equipment**

- Gasket for gas train flange . . . . .No. 1
- Gas flange fixing screws, M 16 x 50 . . . . .No. 8
- Thermal insulation screen . . . . .No. 1
- M 20 x 70 screws to secure the burner to the boiler. . . . . No. 12
- Pressure switch (for leak detection control) . . . . .No. 1
- Light oil flexible hoses . . . . .No. 2
- M20 nuts to secure the burner to the boiler door . . . . . No. 12
- Instruction booklet . . . . . No. 2
- Spare parts list . . . . . No. 1



It is recommended to tighten the screws of the gas flange with a tightening torque of  
 DN80: **40 Nm ±10%**  
 DN100: **50 Nm ±10%**  
 DN125: **60 Nm ±10%**

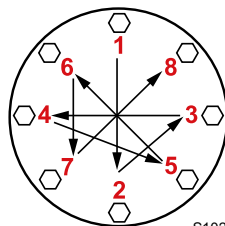

Tighten the nuts gradually (first to 30%, then to 60% up to 100%) according to the cross pattern shown in the figure.

**3.12 AZL Display...**

**Important notes**



**WARNING**

To avoid accidents, material or environmental damage, observe the following instructions!

The AZL... display is a safety device! Avoid opening or modifying it, or forcing its operation. Riello S.p.A. cannot assume any responsibility for damage resulting from unauthorised interventions!

The electronic cam is operated and programmed through the AZL5 interface... or with the aid of a PC.

The AZL5 has a backlit LCD display with clear reading of the menu text and diagnostics.

The Modbus function of the AZL display integrates the electronic cam LMV5 and through data management allows the diagnostic of the burner.

The display shows the operating status, the types of errors and lockouts. Used to parameterize and monitor data.



**Fig. 7**

**Technical data**

Operating voltage	AC 24 V - 15% / +10%
Power consumption	< 5W (typical)
Protection level of the container	
- Rear	IP00 according to IEC 529
- Front	IP54 according to IEC 529 (if installed)
Safety class	I with parts II and III according to DIN EN 60730-1
<b>Battery - Manufacturer:</b>	<b>Type reference:</b>
VARTA	CR 2430 (LF-1/2 W)
DURACELL	DL 2430
SANYO ELECTRIC, Osaka/ Japan	CR 2430 (LF-1/2 W)
RENATA AG, Itingen/CH	CR 2430

**Tab. D**

**3.13 Flame control (LMV52...)**

**Important notes**



To avoid accidents, material or environmental damage, observe the following instructions!

The LMV52 flame control... is a safety device! Avoid opening or modifying it, or forcing its operation. Riello S.p.A. cannot assume any responsibility for damage resulting from unauthorised interventions!

**Risk of explosion!**

An incorrect configuration can provoke fuel overcharging, with the consequential risk of explosion! Operators must be aware that incorrect settings made on the AZL5... display and operating unit and incorrect settings of the fuel and / or air actuator positions can lead to dangerous burner operating conditions.

- All interventions (assembly and installation operations, assistance, etc.) must be carried out by qualified personnel.
- Before modifying the wiring in the LMV52 flame control connection area, fully disconnect the system from the power supply (omnipolar separation). Check the system is not powered and cannot be accidentally reconnected. Failure to do this will lead to the risk of electrocution.
- Protection against electrocution from the LMV5... flame control and all connected electric components is obtained with correct assembly.
- Before any intervention (assembly and installation operations, assistance, etc.), ensure the wiring is in order and that the parameters are correctly set, then make the safety checks.
- Falls and collisions can negatively affect the safety functions.  
In this case, the flame control must not be operated, even if it displays no evident damage.
- In programming mode, the position check of actuators and VSD (checking electronic fuel / air ratio control) is different from the check during automatic operation. As for automatic operation, the actuators are guided together to the positions requested and, if an actuator does not reach the position requested, adjustments are made until the position is actually reached. However, in contrast to automatic operation, there are no time limits to these corrective actions. The other actuators maintain their positions until all actuators have reached the positions currently required.  
This is absolutely important to set the fuel / air ratio control system.  
During the time the fuel / air ratio curves are being programmed, the person making the plant settings must continuously monitor the quality of the combustion process (e.g. by means of a flue gas analyser). Also, if combustion levels are poor, or in the event of dangerous situations, the commissioning engineer must take appropriate action (e.g. switching off manually).

To ensure the safety and reliability of the LMV5... system, the following instructions must also be followed:

- avoid conditions that can favour the development of condensate and humidity. Otherwise, before switching on again, make sure that the entire flame control is perfectly dry!
- Static charges must be avoided since they can damage the flame control's electronic components when touched.



D9301

**Fig. 8**

**Mechanical structure**

The LMV5... flame control is a system to check the burners, based on a microprocessor and equipped with components to adjust and monitor medium and large capacity forced draught burners.

The base flame control of the LMV5... system incorporates the following components:

- Burner control with gas valve proving system
- Electronic fuel / air ratio control with a maximum of 4 (LMV51...) or 6 (LMV52...) actuators
- Optional PID temperature / pressure controller (load controller)
- Optional VSD module Mechanical design

**Installation notes**

- Check the electric wiring inside the boiler complies with the national and local safety regulations.
- Do not confuse the powered conductors with the neutral ones.
- Make certain that strain relief of the connected cables is in compliance with the relevant standards (e.g. as per DIN EN 60730 and DIN EN 60 335).
- Ensure that spliced wires cannot get into contact with neighbouring terminals. Use adequate ferrules.
- Arrange the HV ignition cables separately, as far as possible from the flame control and the other cables
- The burner manufacturer must protect unused AC 230V terminals with dummy plugs (refer to sections Suppliers of other accessory items).
- When wiring the unit, make sure that AC 230V mains voltage cables are run strictly separate from extra low-voltage cables to avoid risks of electrical shock hazard.

### Electrical connection of flame detector

It is important for signal transmission to be almost totally free of any disturbances or loss:

- always separate the detector cables from the other cables:
  - Line capacitance reduces the magnitude of the flame signal.
  - Use a separate cable.
- Respect the allowed cable lengths.

### Technical data

LMV52... base flame control	Mains voltage	AC 230 V -15% / +10%
	Mains frequency	50 / 60 Hz $\pm 6\%$
	Power absorption	< 30W (normal)
	Safety class	I, with components in compliance with II and III, according to DIN EN 60730-1
Load on 'input' terminals	F1 unit fuse (internal)	6.3 AT
	Main fuse of perm. network (external)	Max. 16 AT
	Undervoltage	
	• Safety switch-off from operating position to mains voltage	< AC 186V
	• Restart when mains voltage picks up	> AC 188 V
	Oil pump / magnetic clutch (nominal voltage)	
• Nominal current	2A	
• Power factor	$\cos\phi > 0.4$	
Air pressure switch test valve (nominal voltage)	• Nominal current	0.5A
	• Power factor	$\cos\phi > 0.4$
	<b>Total load on the contacts:</b>	
	• Mains voltage	AC 230 V -15% / +10%
Load on 'output' terminals	• Total unit input current (safety circuit) load on contacts due to:	Max. 5A
	- Fan motor contactor	
	- Ignition transformer	
	- Valve	
	- Oil pump / magnetic clutch	
	<b>Single contact loading:</b>	
	Fan motor contactor (nominal voltage)	
	• Nominal current	1A
	• Power factor	$\cos\phi > 0.4$
	Alarm output (nominal voltage)	
	• Nominal current	1A
	• Power factor	$\cos\phi > 0.4$
	Ignition transformer (nominal voltage)	
• Nominal current	2A	
• Power factor	$\cos\phi > 0.2$	
Fuel gas valve (nominal voltage)		
• Nominal current	2A	
• Power factor	$\cos\phi > 0.4$	
Fuel oil valve (nominal voltage)		
• Nominal current	1A	
• Power factor	$\cos\phi > 0.4$	
Cable lengths	Main line	Max. 100m (100 pF/m)
Environmental conditions	Operation	DIN EN 60721-3-3
	Climatic conditions	Class 3K3
	Mechanical conditions	Class 3M3
	Temperature range	-20...+60°C
	Humidity	< 95% RH

**3.14 Servomotor (SQM48.4....)**

**Important notes**



**To avoid accidents, material or environmental damage, observe the following instructions!**

**WARNING**

**Avoid opening, modifying or forcing the actuators.**

- All interventions (assembly and installation operations, assistance, etc.) must be carried out by qualified personnel.
- Before modifying the wiring in the SQM4... system connection area, fully disconnect the burner control device from the power supply (omnipolar separation).
- To avoid the risk of electrocution, protect the connection terminals in a suitable manner and correctly fix the cover.
- Check the wiring is in order.
- Falls and collisions can negatively affect the safety functions. In this case, the unit must not be operated, even if it displays no evident damage.

**Assembly notes**

- Check the relevant national safety standards are respected.
- The connection between the actuator command shaft and the control element must be rigid, without any mechanical play.
- To avoid an excessive load on the bearings due to rigid hubs, the use of compensation clutches without any mechanical play is recommended (e.g. metal bellows-type clutches).

**Installation notes**

- Arrange the HV ignition cables separately, as far as possible from the flame control and the other cables.
- To avoid the risk of electrocution, make sure that the 230V AC section of the SQM4... unit is fully separated from the functional low-voltage section.
- The static torque is reduced when the electrical supply of the actuator is switched off.
- The housing cover may only be removed for short periods of time for wiring or when making the addressing. In similar cases, make sure that dust or dirt does not penetrate inside the actuator.
- The actuator comprises a PCB with ESD-sensitive components.
- The top side of the board carries a cover which affords protection against direct contact. This protective cover must not be removed! The underside side of the board must not be touched.



**WARNING**

**During the maintenance or replacement of the actuators, be careful not to invert the connectors.**

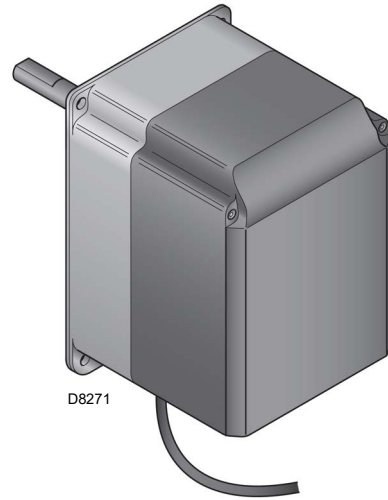

**Fig. 9**

**Technical data**

Operating voltage	AC 2 x 12V via bus cable from the base unit or via a separate transformer
Safety class	extra low-voltage with safe isolation from mains voltage
Power absorption	26...34 VA
Protection level	to EN 60 529, IP 54, provided adequate cable entries are used
Cable connection	RAST3,5 connectors
Rotation direction	- Anticlockwise (standard) - Clockwise (inverted rotation)
Rated torque (max.)	20 Nm
Static torque (max.)	20 Nm
Operation time (min.) for 90°	30 s.
Weight	approx. 1.6 kg
Environmental conditions:	
Operation	DIN EN 60 721-3-3
Climatic conditions	Class 3K3
Mechanical conditions	Class 3M3
Temperature range	-20...+60°C
Humidity	< 95% RH

**Tab. E**

**4 Installation**

**4.1 Notes on safety for the installation**

After carefully cleaning all around the area where the burner is to be installed, and arranging for the environment to be illuminated correctly, proceed with the installation operations.



All the installation, maintenance and disassembly operations must be carried out with the electricity supply disconnected.



The installation of the burner must be carried out by qualified personnel, as indicated in this manual and in compliance with the standards and regulations of the laws in force.



Combustion air inside the boiler must be free from hazardous mixes (e.g.: chloride, fluoride, halogen); if present, it is highly recommended to carry out cleaning and maintenance more frequently.

**4.2 Handling**

The burner packaging includes a wooden platform, it is therefore possible to move the burner (still packaged) with a transpallet truck or fork lift truck.



The handling operations for the burner can be highly dangerous if not carried out with the greatest attention: keep any unauthorised people at a distance; check the integrity and suitability of the available means of handling. Check also that the area in which you are working is empty and that there is an adequate escape area (i.e. a free, safe area to which you can quickly move if the burner should fall). When handling, keep the load at not more than 20-25 cm from the ground.



After positioning the burner near the installation point, correctly dispose of all residual packaging, separating the various types of material.



Before proceeding with the installation operations, carefully clean all around the area where the burner will be installed.

**4.3 Preliminary checks**

**Checking the consignment**



After removing all the packaging, check the integrity of the contents. In the event of doubt, do not use the burner; contact the supplier.



The packaging elements (wooden cage or cardboard box, nails, clips, plastic bags, etc.) must not be abandoned as they are potential sources of danger and pollution; they should be collected and disposed of in the appropriate places.

		A		B	
		D		C	
		E		F	
GAS-KAASU	<input type="checkbox"/> FAM.2	G		H	
GAZ-AEPIO	<input type="checkbox"/> FAM.3	G		H	
		I		I	
		L		L	
				CE	
					

20206732

**Checking the characteristics of the burner**

Check the identification label of the burner, showing:

- the model (A)(Fig. 10) and type of burner (B);
- the year of manufacture, in cryptographic form (C);
- the serial number (D);
- the data for electrical supply and the protection level (E);
- the absorbed electrical power (F);
- the types of gas used and the relative supply pressures (G);
- the data of the burner's minimum and maximum output possibilities (H) (see Firing rate).

**Warning.** The output of the burner must be within the boiler's firing rate;

- the category of the appliance/countries of destination (I).
- light oil maximum viscosity (L).



A burner label that has been tampered with, removed or is missing, along with anything else that prevents the definite identification of the burner makes any installation or maintenance work difficult.

**Fig. 10**

**4.4 Operating position**



- The burner is designed to operate only in positions 1, 2, 3 and 4 (Fig. 11).
- Installation 1 is preferable, as it is the only one that allows the maintenance operations as described in this manual.
- Installations 2, 3 and 4 permit operation but make maintenance and inspection of the combustion head more difficult.



- Any other position could compromise the correct operation of the appliance.
- Installation 5 is prohibited for safety reasons.

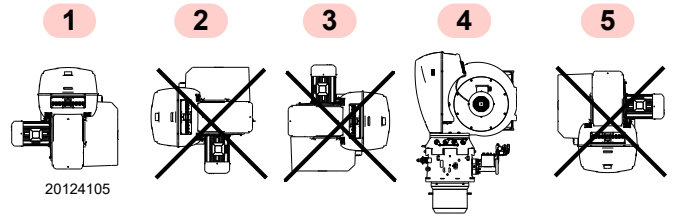

**Fig. 11**

**4.5 Removing the shutter lockout screws**

Remove the screws 1)-2) and nuts before fitting the burner onto the boiler (Fig. 12). Replace them with the screws 3) M12x16 supplied as standard.

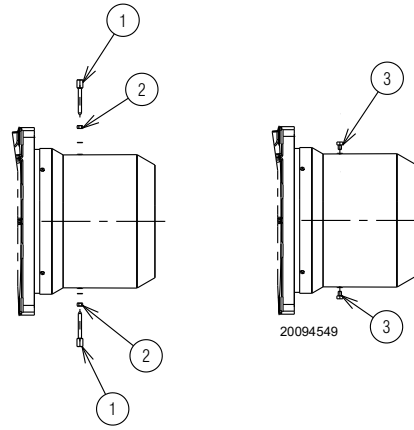

**Fig. 12**

**4.6 Coupling of the burner - Centre of gravity position**



Provide an adequate lifting system.



Hook and lift the burner as shown in Fig. 13

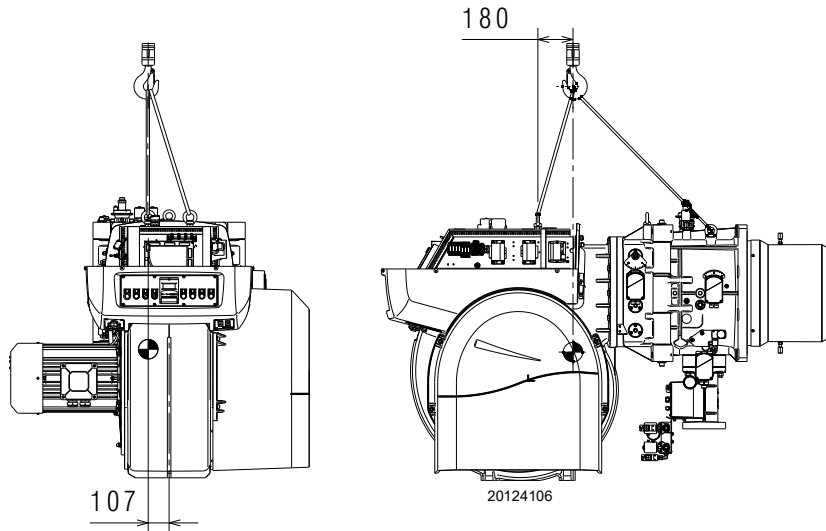

**Fig. 13**

**4.7 Preparing the boiler**

**4.7.1 Boring the boiler plate**

Pierce the closing plate of the combustion chamber, as in Fig. 14. The position of the threaded holes can be marked using the thermal insulation screen supplied with the burner.

**4.7.2 Blast tube length**

The length of the blast tube must be selected according to the indications provided by the manufacturer of the boiler, and in any case it must be greater than the thickness of the boiler door complete with its fettling.

For boilers with a front flue gas passes 1) (Fig. 15) or flame inversion chamber, a protection device in refractory material 5) must be inserted between the boiler fettling 2) and the blast tube 4).

This protective fettling must not compromise the extraction of the blast tube.

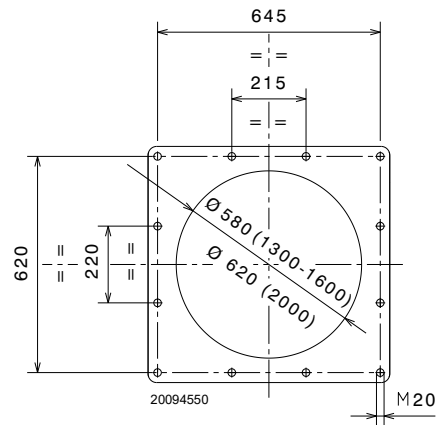

Fig. 14

**4.8 Securing the burner to the boiler**



Prepare a suitable lifting system using the rings 3)(Fig. 15), after having removed the screws 7) and cover 8).



**The seal between burner and boiler must be airtight.**

- Insert the thermal protection supplied with the blast tube 4).
- Insert the entire burner on the boiler hole, previously fitted, as in Fig. 14, and fix it with the screws supplied.

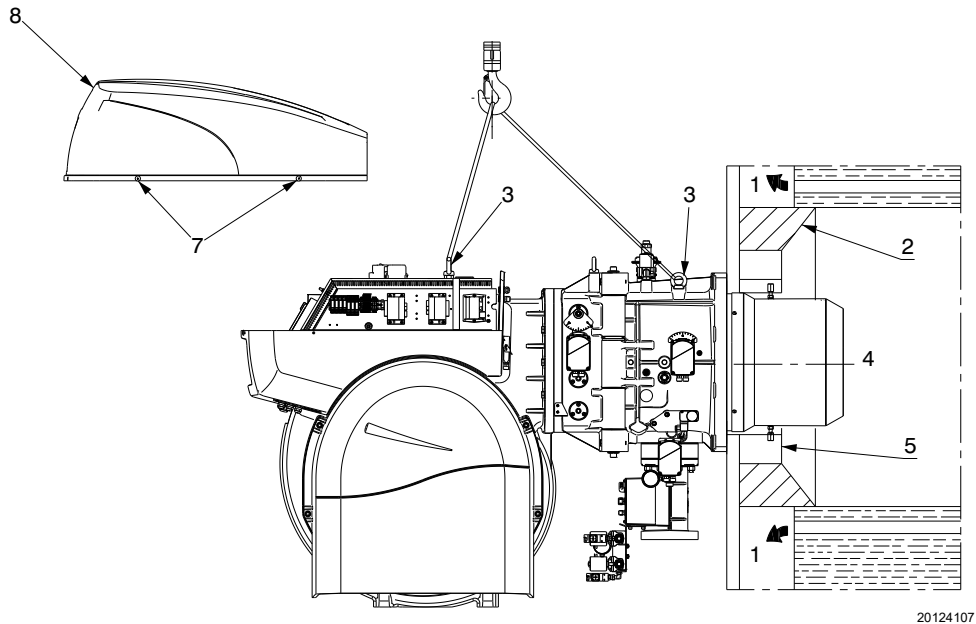

20124107

Fig. 15

### 4.9 Access to head internal part

In order to reach inside the combustion head (Fig. 16) proceed as follows:

- disconnect the derivation unit socket 1) and the QRI flame sensor 2);
- disconnect the servomotor sockets;
- remove the cover;
- disconnect the cable of the electrode 12) from the transformer 13) and remove it by unscrewing the fitting 14);
- unscrew the 4 fixing screws of the pipe coupling 4);
- open the burner on the hinge

- disconnect the cable of the pilot electrode 5);
- release the ignition pilot fitting 6);
- disconnect the light oil pipes 7);
- unscrew the lockout screw 9) of the oil lance 10);
- extract the oil lance 10) from the combustion head 11);
- extract the combustion head of the head 11).



Be careful as fuel may leak during this phase.

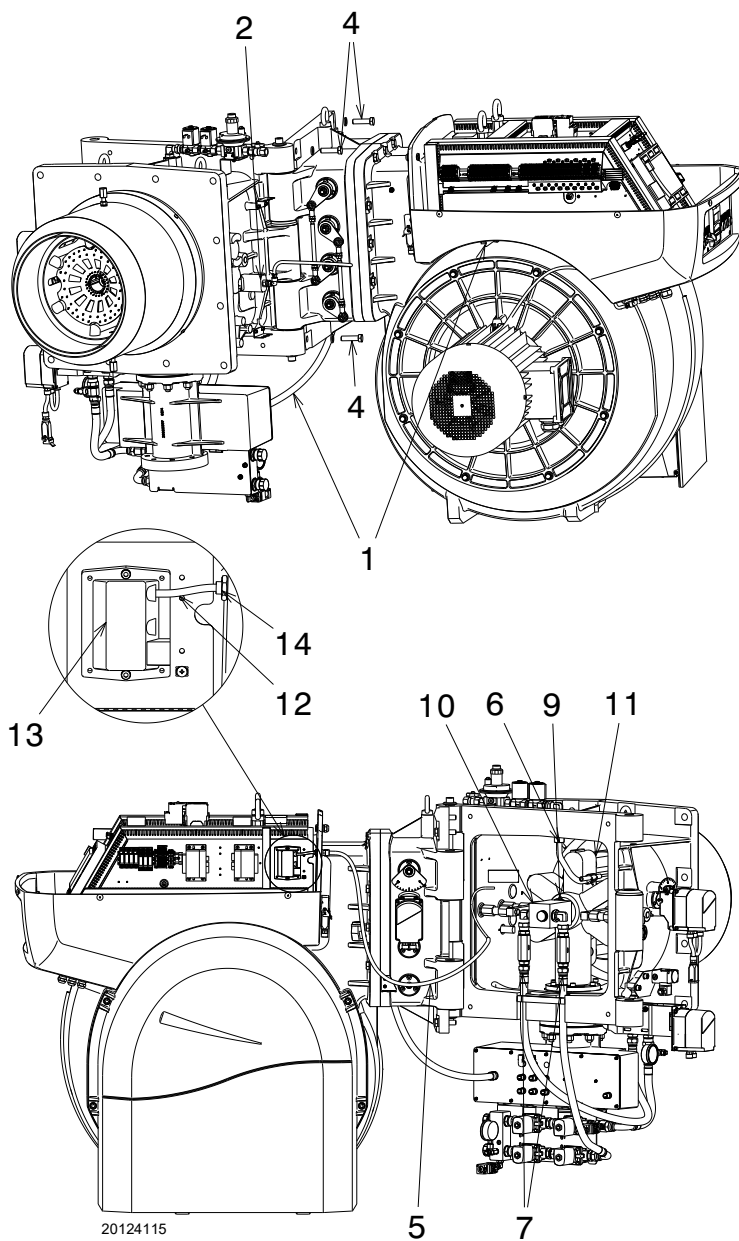

Fig. 16

**4.10 Nozzle installation**

The burner complies with the emission requirements of the EN 267 standard. In order to guarantee that emissions do not vary, recommended and/or alternative nozzles specified by Riello in the Instruction and warning booklet should be used.



It is advisable to replace the nozzle once a year during periodical maintenance.



The use of nozzles other than those specified by Riello S.p.A. and inadequate regular maintenance may result into emission limits non-conforming to the values set forth by the regulations in force, and in extremely serious cases, into potential hazards to people and objects.

The manufacturing company shall not be liable for any such damage arising from non-observance of the requirements contained in this manual.

Fit the nozzle with the 24-mm pipe wrench, passing through the central opening of the flame balance disc (Fig. 17) or remove the lance.



- Do not use any sealing products such as: gaskets, sealing compound, or tape.
- Be careful to avoid damaging the nozzle sealing seat.
- The nozzle must be screwed into place tightly but not to the maximum torque value provided by the wrench.

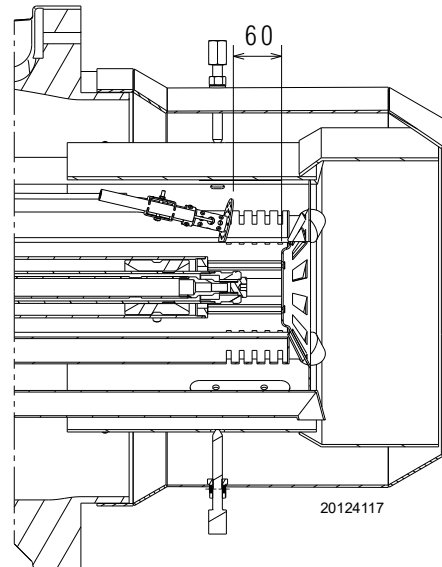

**Fig. 17**

**4.10.1 Recommended nozzle**

**Complete range of nozzles:**

- Fluidics type 22N1:  
400 - 450 - 500 - 550 - 600 - 650 - 700 - 750 - 800 - 850 - 900 - 950 - 1000 - 1100 - 1200 - 1300 - 1400 - 1500.

**4.11 Electrode position**



Position the electrode on the ignition pilot as shown in Fig. 18.

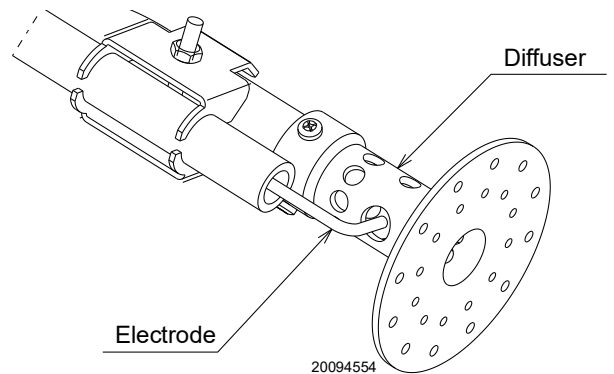

**Fig. 18**

**4.12 Combustion head adjustment**

The air damper servomotor 4)(Fig. 19), varies the air output according to the output demand, while another servomotor varies the combustion head adjustment.

This system allows an optimum adjustment also at the minimum firing rate.



The gas pipes leave the factory calibrated at notch 1.

The adjustment shown in Fig. 20 allows the gas pipes to be positioned in the best way for the application on which the burner is installed (e.g. boilers with flame inversion chamber).

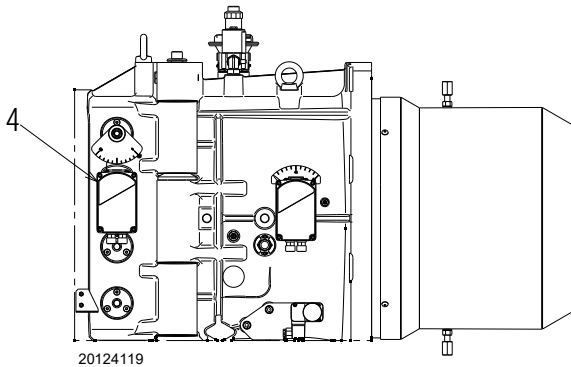

**Fig. 19**

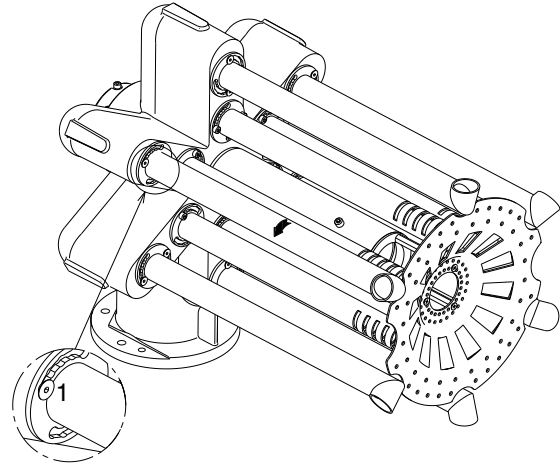

**Fig. 20**

**4.13 Light oil supply**



Explosion danger due to fuel leaks in the presence of a flammable source.

Precautions: avoid knocking, attrition, sparks and heat.

Make sure the fuel interception tap is closed before performing any operation on the burner.



**WARNING**

The fuel supply line must be installed by qualified personnel, in compliance with current standards and laws.

**4.13.1 Double-pipe circuit**

The burner must be combined with a suitable pumping unit suitable for the output to be produced; refer to the supplied instruction booklet to determine the diameters of the fuel supply pipes based on the head necessary for the correct operation of the system.

The pump unit models available in combination with these burners are indicated in the final pages of this instruction booklet.

**4.13.2 Hydraulic connections**



- Make sure that the flexible hoses to the pump supply and return line are installed correctly.



Follow the instructions below:

- Tighten the flexible hoses with the supplied gaskets.
- Take care that the hoses are not stretched or twisted during installation.
- Place the pipes so that they are not crushed or are in contact with hot parts of the boiler and so it is possible to open the burner.
- Finally, connect the other end of the flexible hoses to the suction and return pipes.

**4.13.3 Hydraulic circuit diagram**

Key (Fig. 21)

- 1 Pump suction
- 2 Pump return line and nozzle return line
- 3 Pump pressure regulator
- 4 Delivery safety valve
- 5 Delivery safety valve
- 6 Nozzle delivery line
- 7 Nozzle without interception rod
- 8 Nozzle return line
- 9 Pressure variator on nozzle return line
- 10 Pressure variator servomotor
- 11 Pressure switch on nozzle return line
- 12 Safety valve on nozzle return line
- 13 Safety valve on nozzle return line
- 14 Pressure switch on pump delivery line
- M Pressure gauges
- V Vacuumeter connection

**OPERATION**

**Pre-purging phase:**

valves 4), 5), 12) and 13) closed.

**Ignition and operation phase:**

valves 4), 4), 12) and 13) open.

**Stop:** All valves closed.

**4.13.4 Pressure variator**

The pressure variator (Fig. 22), allows the pressure on the return line of the nozzle to be varied according to the required output.

The pressure on the return line is adjusted by varying a section by means of the rotation of the servomotor 23)(Fig. 5, page 11), which also controls the gas butterfly valve at the same time.

- Regulator at 0° (maximum opening) = minimum pressure on the nozzle return line.
- Regulator at 90° (minimum opening) = maximum pressure on the nozzle return line.

The servomotor is controlled by the electronic cam, thanks to this device, it is possible to set different curves for oil and gas on the same servomotor (also for the air damper servomotor).

- When **adjusting the gas**, it is recommended the servomotor be adjusted to about 90° to reduce leaks from the gas butterfly valve.
- When **adjusting the oil**, the adjustment is done based on the nozzle fitted and on the required degree of modulation; in a situation of minimum firing rate, a rotation of 20° can be enough.

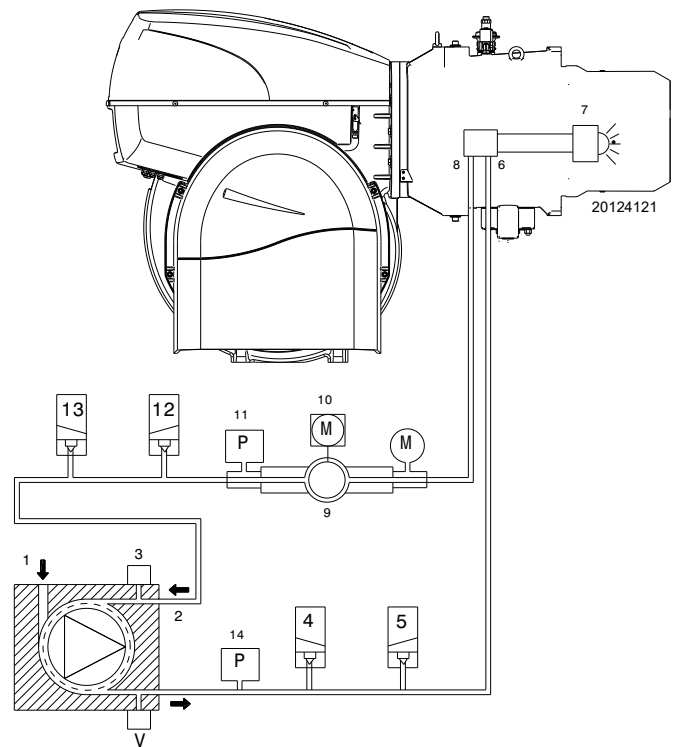

**Fig. 21**

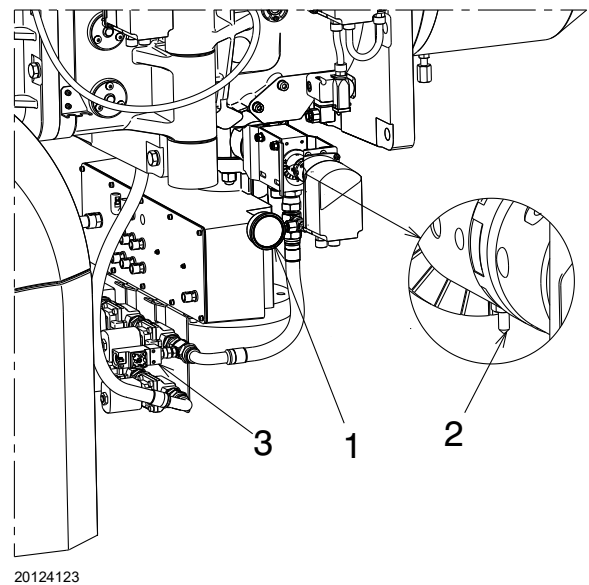

**Fig. 22**

Key (Fig. 22)

- 1 Nozzle return pressure gauge
- 2 Position indicator (0 ÷ 90) of the pressure variator
- 3 Maximum oil pressure switch on return circuit

### 4.14 Gas feeding



Explosion danger due to fuel leaks in the presence of a flammable source.

Precautions: avoid knocking, attrition, sparks and heat.

Make sure the fuel interception tap is closed before performing any operation on the burner.



The fuel supply line must be installed by qualified personnel, in compliance with current standards and laws.

#### 4.14.1 Gas feeding line (Example) - Please refer to the gas train documentation for more information

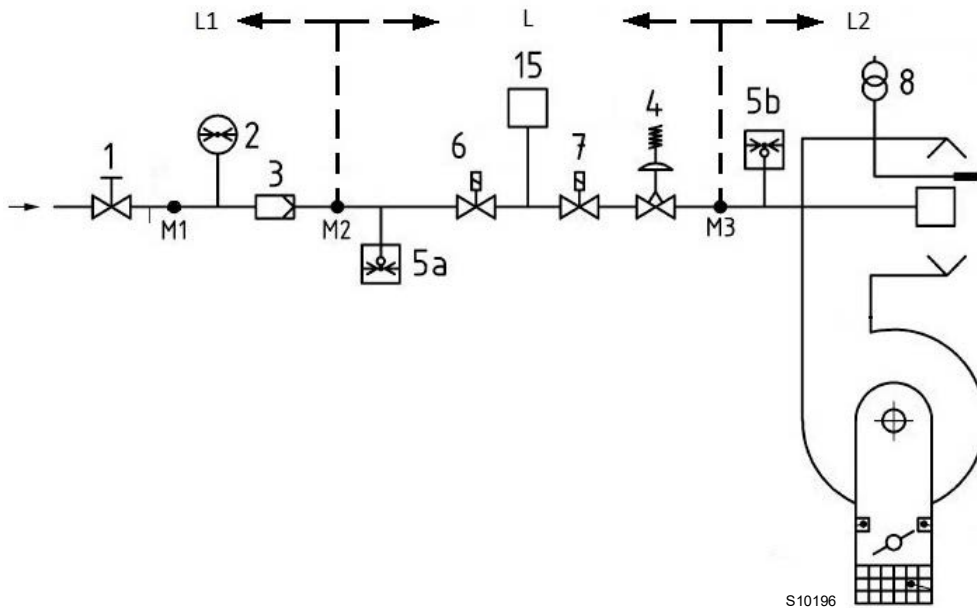

Fig. 23

#### Key (Fig. 23)

- 1 Manually operated shut-off valve
- 2 Pressure gauge
- 3 Filter
- 4 Governor
- 5a Low pressure protection device
- 5b Maximum gas pressure switch
- 6 1st safety shut-off device
- 7 2nd safety shut-off device
- 8 Ignition device
- 15 Valve leak detection control system
- L Gas train (supplied separately)
- L1 Responsibility of the installer
- L2 Burner
- M1 Pressure test point
- M2 Pressure test point
- M3 Pressure test point

**4.14.2 Gas train**

Approved according to standard EN 676 and provided separately from the burner.

**4.14.3 Gas train installation**



Disconnect the electrical power using the main switch.



Check that there are no gas leaks.



Pay attention when handling the train: danger of crushing of limbs.



Make sure that the gas train is properly installed by checking for any fuel leaks.



The operator must use the required equipment during installation.

The gas train is prearranged to be connected to the burner by the flange 1)(Fig. 24).

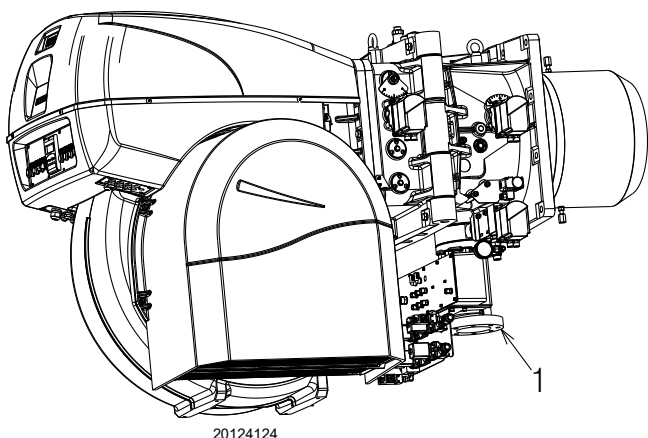

Fig. 24



**Data of head thermal power and gas pressure refer to operation with gas butterfly valve fully open (90°).**

**4.14.4 Gas pressure**

Tab. F indicates the pressure drop of the combustion head and the gas butterfly valve depending on the operating output of the burner.

	kW	1 Δp (mbar)		2 Δp (mbar)	
		G 20	G 25	G 20	G 25
RLS 1600/EV	9503	23	34	13	19
	10200	27	40	14	21
	10900	31	46	15	22
	11600	35	52	16	24
	12400	41	61	17	25
	13100	46	69	18	27
	13800	51	76	20	30
	14500	56	83	22	33
	15200	62	92	24	36
	15560	66	98	26	39
RLS 2000/EV	15200	58	86	11	16
	15700	62	92	13	19
	16300	67	100	16	24
	16800	71	106	19	28
	17400	76	113	21	31
	17900	81	121	24	36
	18500	87	130	27	40
	19000	92	137	30	45
	19600	98	146	33	49
	20100	104	155	36	54

Tab. F

The values shown in Tab. F refer to:

- Natural gas G 20 NCV 9.45 kWh/Sm<sup>3</sup> (8.2 Mcal/Sm<sup>3</sup>)
- Natural gas G 25 NCV 8.13 kWh/Sm<sup>3</sup> (7.0 Mcal/Sm<sup>3</sup>)

Column 1

Combustion head pressure drop.

Gas pressure measured at test point 1)(Fig. 25), with:

- combustion chamber at 0 mbar;
- burner working at maximum modulating output;
- combustion head set as on page 22.

Column 2

Pressure loss at gas butterfly valve 2)(Fig. 25) with maximum opening: 90°.

To calculate the approximate output at which the burner operates:

- subtract the pressure in combustion chamber from the gas pressure measured at test point 1)(Fig. 25).
- Find, in Tab. F related to the burner concerned, the pressure value closest to the result of the subtraction.
- Read off the corresponding output on the left.

**Example RLS 1600/EV C11 with natural gas G20:**

Operation at maximum modulating output  
 Gas pressure at test point 1)(Fig. 25) = 46 mbar  
 Pressure in combustion chamber = 5 mbar  
 46 - 5 = 41 mbar

A pressure of 41 mbar, (column 1, corresponds in Tab. F to an output of 12400 kW.

This value serves as a rough guide; the effective output must be measured at the gas meter.

To calculate the required gas pressure at test point 1)(Fig. 25), set the maximum modulating output required from the burner operation:

- find the nearest output value in Tab. F for the burner in question.
- read, on the right (column 1), the pressure at the test point 1)(Fig. 25).
- Add this value to the estimated pressure in combustion chamber.

**Example RLS 1600/EV C11 with natural gas G20:**

Operation at maximum modulating output  
 Gas pressure at an output of 12400 kW = 41 mbar  
 Pressure in combustion chamber = 5 mbar  
 41 + 5 = 46 mbar  
 pressure required at test point 1)(Fig. 25).

**4.14.5 Pilot - gas train connection**

The burner is fitted with a dedicated gas train that is fixed to the pipe coupling.

- It should be connected to the main train downstream the filter or the pressure adjuster (depending on configuration).



Supply pressure 68 ± 500 mbar.

**4.14.6 Ignition pilot burner**

For proper operation, adjust gas pressure (measured at pressure test point 1)(Fig. 26) as follows:

Model	Gas	mbar	Sm <sup>3</sup> /h
RLS 1600/EV C11	G20	26	19
RLS 2000/EV C11	G20	26	19

**Tab. G**



Check pilot flame stability before starting up the main burner.

In the case of ignition problems check:

- correct positioning of the ignition electrode;
- the gas pressure, according to indications.

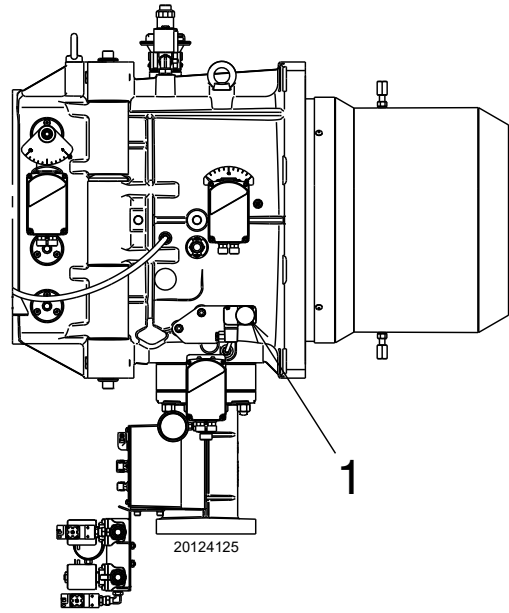

**Fig. 25**

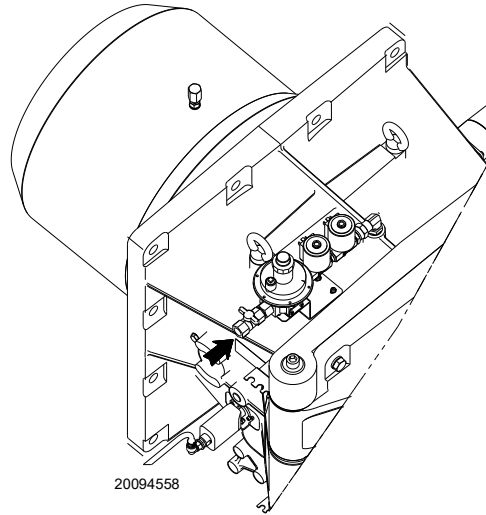

**Fig. 26**

**4.15 Electrical wiring**

**Notes on safety for the electrical wiring**



- The electrical wiring must be carried out with the electrical supply disconnected.
- Electrical wiring must be made in accordance with the regulations currently in force in the country of destination and by qualified personnel. Refer to the wiring diagrams.
- The manufacturer declines all responsibility for modifications or connections different from those shown in the wiring diagrams.
- Check that the electrical supply of the burner corresponds to that shown on the identification label and in this manual.
- The burner has been type-approved for intermittent operation (FS1). This means that it should as a rule be stopped at least once every 24 hours to enable the flame control to perform checks of its own start-up efficiency. Normally, burner stopping is guaranteed by the boiler's thermostat/pressure switch. If this is not the case, a time switch should be fitted in series to TL to stop the burner at least once every 24 hours. Refer to the wiring diagrams.
- The burner is factory set for FS1 operation (1 stop every 24 hours); it can be converted to FS2 operation (continuous - 1 stop every 72 hours), by changing the parameters using the menu of the AZL Display.
- The electrical safety of the device is obtained only when it is correctly connected to an efficient earthing system, made according to current standards. It is necessary to check this fundamental safety requirement. In the event of doubt, have the electrical system checked by qualified personnel. Do not use the gas tubes as an earthing system for electrical devices.
- The electrical system must be suitable for the maximum power absorption of the device, as indicated on the label and in the manual, checking in particular that the section of the cables is suitable for that level of power absorption.
- For the main power supply of the device from the electricity mains:
  - do not use adapters, multiple sockets or extensions;
  - make provisions for an omnipolar switch with a gap between the contacts of at least 3 mm (over-voltage category III), as required by current safety regulations.
- Do not touch the device with wet or damp body parts and/or in bare feet.
- Do not pull the electric cables.

**4.15.1 Notes on terminals**

Two types of terminals with "spring" system can be found on the electrical panel. The opening of these terminals must be made via a suitable tool, using a flat-blade screwdriver of the correct size. The first type of terminal "A" (present on the "2000" burner) is reserved for the connection of the three-phase line and has a rotation type opening. The second type "B" has a pressure opening system.

**Type "A" terminal opening (Fig. 27)**

- Insert the correct screwdriver into the hole until it stops, rotate anti-clockwise pushing down (the terminal can be kept open by pressing the orange button).
- Insert the previously stripped cable, turn the screwdriver slightly and pull it out. Make sure the cable is securely fastened Fig. 27.

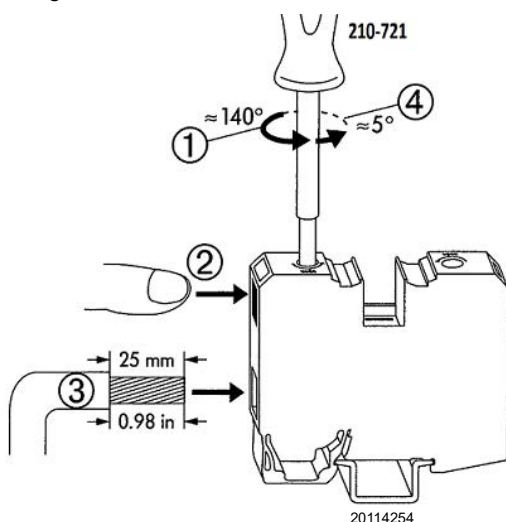

**Fig. 27**

**Type "B" terminal opening (Fig. 28)**

- insert the correct screwdriver into the opening, pushing down until the hole for the cable is completely open.
- Insert the previously stripped cable and remove the screwdriver. Make sure the cable is securely fastened Fig. 28.

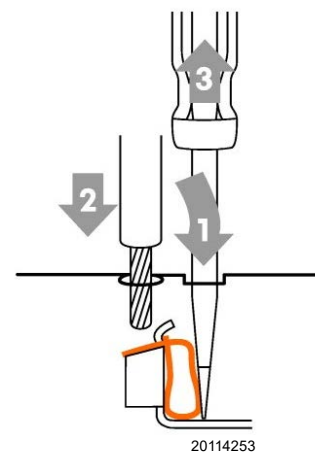

**Fig. 28**

Before carrying out any maintenance, cleaning or checking operations:



Turn off the burner's electrical supply using the main system switch.



Turn off the fuel interception tap.



Avoid condensate, ice and water leaks from forming.

If the cover is still present, remove it and proceed with the electrical wiring according to the wiring diagrams.

Use flexible cables in compliance with the EN 60 335-1 standard.

### 4.15.2 Supply cables and external connections passage

All the cables to be connected to the burner should be passed through cable grommets, as shown in Fig. 29.



To guarantee the protection level of the burner, it is necessary to close any holes and fairleads not used using the plugs supplied.

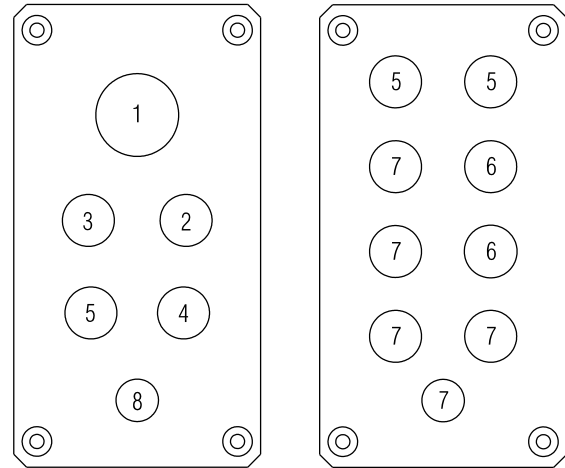

20096726

**Fig. 29**

Key (Fig. 29)

- 1 Electrical supply
- 2 Minimum gas pressure switch
- 3 Pressure switch for VPS gas valve leak detection
- 4 Gas train
- 5 Consents/Safety
- 6 Available
- 7 Plug
- 8 Rpm sensor cable outlet



After carrying out maintenance, cleaning or checking operations, reassemble the cover and all the safety and protection devices of the burner.

**4.15.3 Shielding the connections**



For the burner to operate correctly, where required, it is necessary to shield the connections.

**WARNING**

To shield the motor connection, proceed as follows:

- to access the motor casing, loosen the four screws 1)(Fig. 30) and remove the cover 2).



To make the correct shielding, it is important to bear in mind the necessary length of the connections inside the motor casing.

**CAUTION**

- Shield the cable 4) running from the VSD (inverter), as shown in Fig. 31 and using the coupling 3).
- Install the cable 4) with its connection to the motor casing, securing it carefully.
- Carry out the motor connection as shown in the wiring diagrams.
- Fix the grommets/cable terminals of the connections securely and tidily to the terminal board of the motor.
- In the protective earth "PE" on the body of the fan motor, install the ground wire 5) fixing the eye 8) with the screw 6) outside the motor box putting the washers 7) in-between.
- Make a final visual check, then close the motor casing by tightening the 4 screws 1)(Fig. 30).

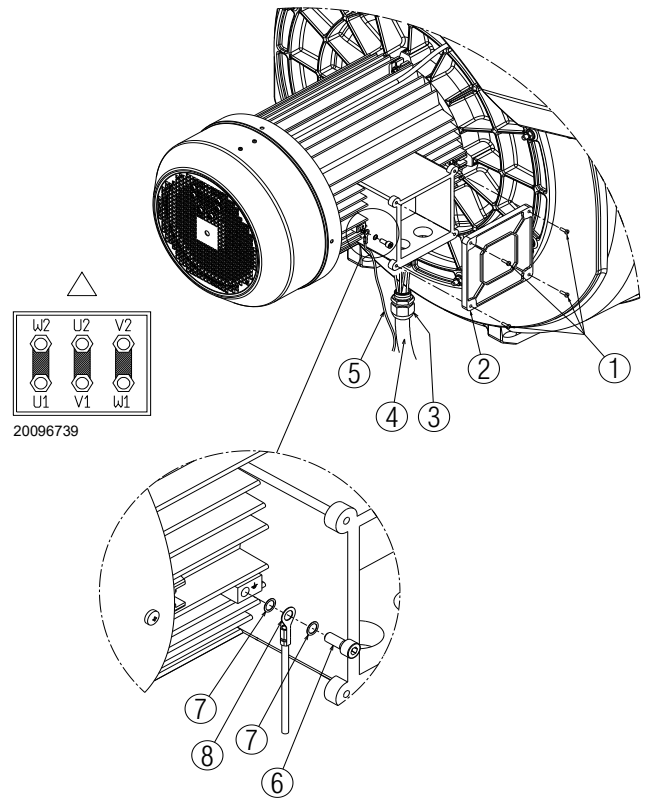

**Fig. 30**

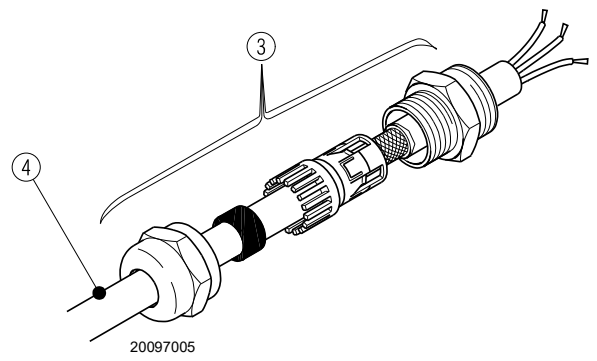

**Fig. 31**

**4.16 Motor rotation**

As the burner is not fitted with a phase sequence checking device, the motor rotation may be incorrect.



As soon as the burner starts up, go in front of the fan motor cooling fan and check it is rotating anti-clockwise (Fig. 32).

**WARNING**

If this is not the case:

- turn the burner switch to position "0" (OFF) and wait for the flame control to carry out the switch-off phase;
- disconnect the power supply to the main panel;
- invert the phases on the three-phase power supply.



This operation must be carried out with the electrical supply disconnected.

**DANGER**

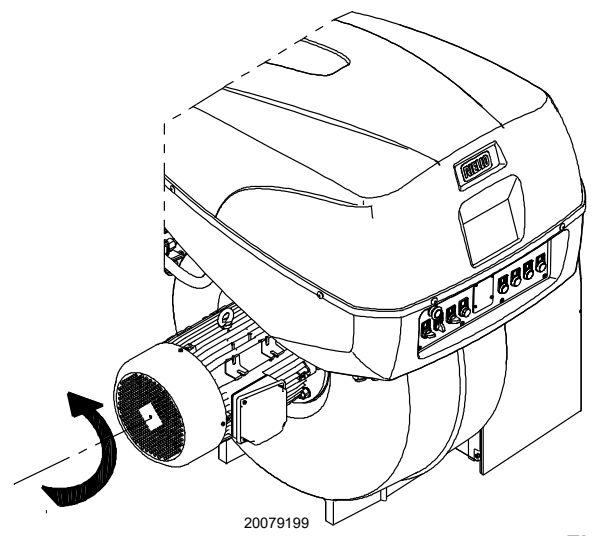

**Fig. 32**

#### 4.17 Calibration of the thermal relay

The thermal relay (Fig. 33) serves to avoid damage to the motor due to an excessive absorption increase or if a phase is missing.

For calibration 2), refer to the table indicated in the electrical layout (electrical wiring in charge of the installer).

To reset, in case of an intervention of the thermal relay, press button "RESET" 1).

The button "STOP" 3) opens the NC contact (95-96) and stops the motor.

Insert a screwdriver in the window "TEST/TRIP" 4) and move it in the arrow direction (to the right) to carry out the thermal relay test.

**The burner leaves the factory set for the 5.5 kW pump motor.**

**Adjust the relay according to the output of the pump that will be installed.**

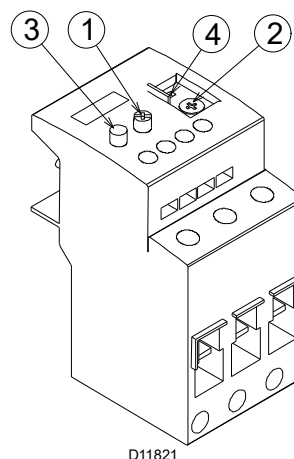

D11821



The automatic reset can be dangerous.

This operation is not foreseen in the burner operation.

Fig. 33

**5 Start-up, calibration and operation of the burner**

**5.1 Notes on safety for the first start-up**



The first start-up of the burner must be carried out by qualified personnel, as indicated in this manual and in compliance with the standards and regulations of the laws in force.



Check the correct working of the adjustment, command and safety devices.



Before starting up the burner, refer to section See “Safety test - with no gas supply” on page 36.

**5.2 Adjustments prior to ignition (light oil)**



It is recommended to adjust first the light oil burner and then the gas burner.

Carry out the fuel change with burner off.

The optimum calibration of the burner requires an analysis of the flue gases at the boiler outlet and interventions on the following points.

**5.2.1 Nozzle**

See information on page 21.

**5.2.2 Combustion head**

The adjustment of the combustion head already carried out on page 22 need not be altered unless the 2nd stage delivery of the burner is changed.

**5.3 Burner ignition (light oil)**

Position the selector 1)(Fig. 34) in “**AUTO**”.

Position the selector 2) in “**OIL**” to select light oil fuel.

When the limit thermostat (TL) is closed, the “**HEAT REQUEST**” 3) signal must be switched on.

At first ignition, there is a momentary drop in fuel pressure due to the filling of the nozzle piping. This lowering of the fuel pressure

can cause the burner to lockout and can sometimes give rise to pulsations.

Once the following adjustments have been made, the ignition of the burner must generate a noise similar to the noise generated during operation.

If a burner lockout occurs, refer to the “Release procedure” given in the equipment manual supplied.

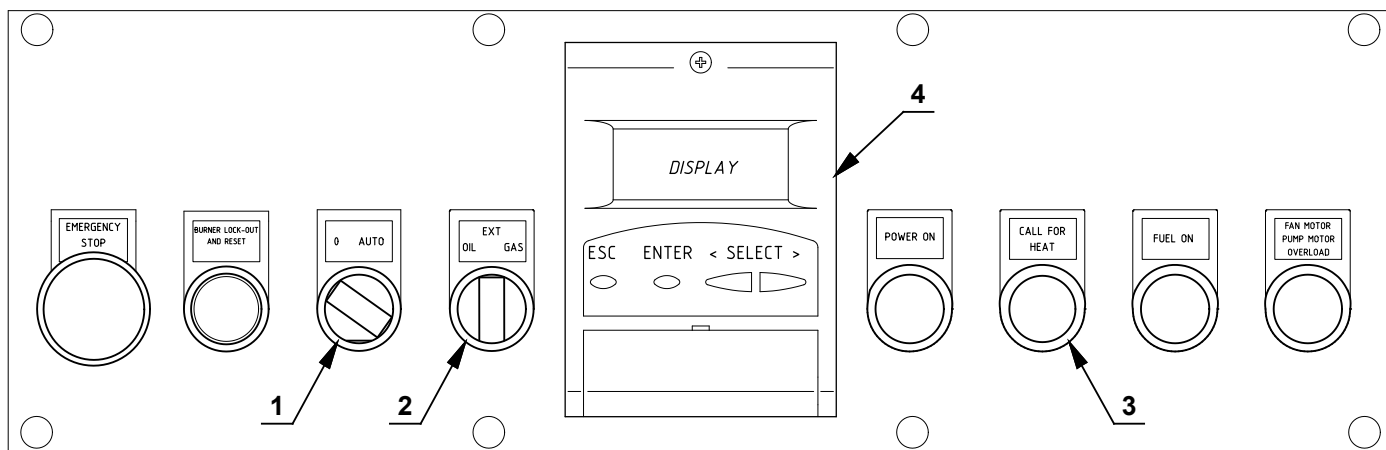

S8384

**Fig. 34**

### 5.4 Adjustments prior to ignition (gas)

In addition, the following adjustments must also be made:

- Slowly open the manual valves situated upstream from the gas train.
- Adjust the minimum gas pressure switch (Fig. 38) to the start of the scale.
- Adjust the maximum gas pressure switch (Fig. 37) to the end of the scale.
- Adjust the air pressure switch (Fig. 36) to the start of the scale.
- Purge the air from the gas line. We recommend using a plastic tube routed outside the building and to purge air until gas is smelt.
- Fit a U-type pressure gauge or a differential pressure gauge (Fig. 35), with socket (+) on the gas pressure of the pipe coupling and (-) in the combustion chamber. The manometer readings are used to calculate MAX burner output.
- Connect two lamps or testers to the two gas line solenoids to check the exact moment in which voltage is supplied. This operation is unnecessary if each of the two solenoid valves is equipped with a pilot light that signals voltage passing through.



Before starting up the burner, it is good practice to adjust the gas train so that ignition takes place in conditions of maximum safety, i.e. with gas delivery at the minimum.

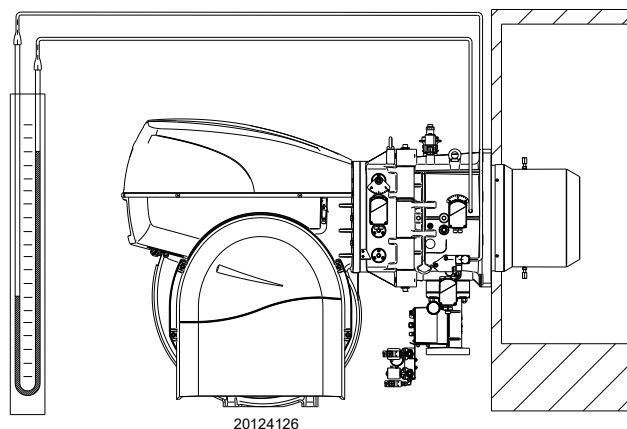

Fig. 35

### 5.5 Burner start-up (gas)

Close the remote controls and position the selector 1)(Fig. 34) to "AUTO".

Position the selector 2) to "GAS" to select gas as fuel.

Make sure that the lights or testers connected to the solenoids, or the pilot lights on the solenoids themselves, indicate that no voltage is present. If voltage is present, stop the burner immediately and check the electrical connections.

When the limit thermostat (TL) closes, the "CALL FOR HEAT" 3) signal must come on. The burner will subsequently begin its starting cycle.

### 5.6 Burner ignition

The burner should light after having performed the above steps. If the motor starts up, but the flame does not appear and the flame control goes into lockout, reset it and wait for a new ignition attempt.

If ignition is still not achieved, it may be that gas is not reaching the combustion head within the safety time period of 3 seconds; In this case increase gas ignition delivery.

The arrival of gas at the sleeve is indicated by the U-type manometer (Fig. 35).

If further burner lockouts occur, refer to the "Release procedure" given in the equipment manual supplied.

Once the burner has fired, now proceed with global calibration operations.

### 5.7 Change of fuel

There are three options of change of fuel:

- 1 with the AZL device 4)(Fig. 34);
- 2 with selector 2);
- 3 with a remote selector connected to the main terminal board.

Positioning the selector 2)(Fig. 34) to "EXT" activates the remote selection of the fuel. In this position, if there is no remote selector, the AZL device defines the priority fuel and the selected fuel is shown on the display.

**5.8 Combustion air adjustment**

Fuel/combustion air synchronisation is done with the relevant servomotors (air and gas) by logging a calibration curve by means of the electronic cam.

It is advisable, to reduce the loss and for a wide calibration field, to adjust the servomotors to the maximum of the output used, the nearest possible to the maximum opening (90°).

On the gas butterfly valve, fuel step according to the burner output required, with servomotor completely open, is carried out by the pressure stabiliser placed on the gas train.

The values indicated in Tab. H and Tab. I can be a reference for a good combustion calibration.

EN 676		Air excess		CO
		Max. output $\lambda \leq 1.2$	Max. output $\lambda \leq 1.3$	
GAS	Theoretical max CO <sub>2</sub> 0 % O <sub>2</sub>	CO <sub>2</sub> % Calibration		mg/kWh
		$\lambda = 1.2$	$\lambda = 1.3$	
G 20	11.7	9.7	9	≤ 100
G 25	11.5	9.5	8.8	≤ 100
G 30	14.0	11.6	10.7	≤ 100
G 31	13.7	11.4	10.5	≤ 100

**Tab. H**

EN 267		Air excess		CO
		Max. output $\lambda \leq 1.2$	Min. output $\lambda \leq 1.3$	
Theoretical max CO <sub>2</sub> 0 % O <sub>2</sub>		CO <sub>2</sub> % Calibration		mg/kWh
		$\lambda = 1.2$	$\lambda = 1.3$	
	15.2	12.6	11.5	≤ 100

**Tab. I**

**5.8.1 Air / gas adjustment and output modulation**

The air/gas adjustment and output modulation system with which the **RLS** range burners are equipped carries out a series of integrated functions in order to optimise burner functioning, both for single operation and together with other units (e.g. double furnace boiler or more than one generator in parallel).

The basic system functions control:

- 1 The dosage of the air and fuel through positioning using direct servo commands of the relevant valves eliminating the possible play in the calibration systems with mechanical cam lever mechanisms, used on traditional modulating burners.
- 2 The modulation of the burner output in accordance with the load required by the system, with maintenance of the pressure or temperature of the boiler at the operating values set.
- 3 The sequence (cascade adjustment) of more than one boiler through the suitable connection of the various units and the activation of the internal software of the individual systems (option).

Further interfaces and communication functions with computers, for remote control or integration in central supervision systems are available on the basis of the configuration of the system.



**WARNING**

The first start up and every further internal setting operation of the adjustment system or the expansion of the base functions require access by means of password and are to be carried out by service personnel who are especially trained for the internal programming of the instrument and the specific application created with this burner.

The first start-up and curve synchronisation manual is supplied with the burner.

At request, the complete manual for the control and setting of all parameters is available.

**5.9 Pressure switch adjustment**

**5.9.1 Air pressure switch - check CO**

Adjust the air pressure switch after performing all other burner adjustments with the air pressure switch set to the start of the scale (Fig. 36).

With the burner operating at MIN output, insert a combustion analyser in the stack, slowly close the suction inlet of the fan (for example, with a piece of cardboard) until the CO value does not exceed 100 ppm.

Slowly turn the appropriate knob clockwise until the burner goes into lockout.

Check the indication of the arrow pointing upwards on the graduated scale.

Turn the knob clockwise again, until the value shown on the graduated scale corresponds with the arrow pointing downwards, and so recovering the hysteresis of the pressure switch (shown by the white mark on a blue background, between the two arrows). Now check the correct start-up of the burner.

If the burner locks out again, turn the knob anticlockwise a little bit more.



Connecting the air pressure switch in differential mode, the burner will no longer be certified according to the EN 676 standard.

**5.9.2 Maximum gas pressure switch**

Adjust the maximum gas pressure switch (Fig. 37) after making all other burner adjustments with the maximum gas pressure switch set to the end of the scale.

To calibrate the maximum gas pressure switch, open the tap and then connect a pressure gauge to its pressure test point.

The maximum gas pressure switch must be regulated to a value no higher than 30% of the measurement read on the gauge when the burner is working at maximum output.

After making the adjustment, remove the pressure gauge and close the tap.

**5.9.3 Minimum gas pressure switch**

The purpose of the minimum gas pressure switch is to prevent the burner from operating in an unsuitable way due to too low gas pressure.

Adjust the minimum gas pressure switch (Fig. 38) after having adjusted the burner, the gas valves and the gas train stabiliser. With the burner operating at maximum output:

- install a pressure gauge downstream of the gas train stabiliser (for example at the gas pressure test point on the burner combustion head);
- choke slowly the manual gas cock until the pressure gauge detects a decrease in the pressure read of about 0.1 kPa (1 mbar). In this phase, verify the CO value which must always be less than 100 mg/kWh (93 ppm).
- Increase the adjustment of the gas pressure switch until it intervenes, causing the burner shutdown;
- remove the pressure gauge and close the cock of the gas pressure test point used for the measurement;
- open completely the manual gas cock.



1 kPa = 10 mbar

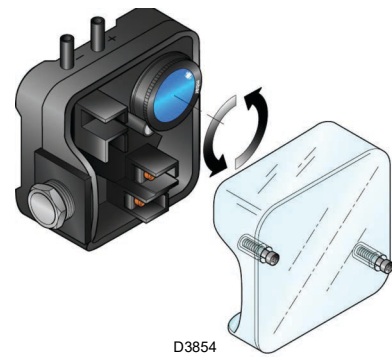

**Fig. 36**

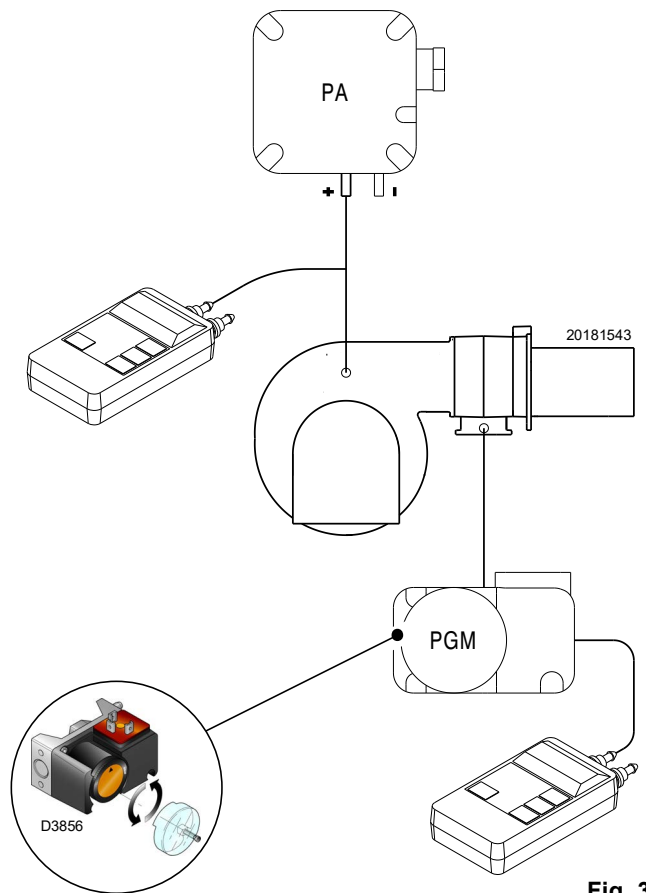

**Fig. 37**

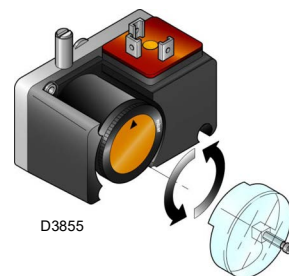

**Fig. 38**

**5.9.4 PVP pressure switch kit**

Adjust the pressure switch for the leak detection control (PVP kit) (Fig. 39) according to the instructions supplied with the kit.

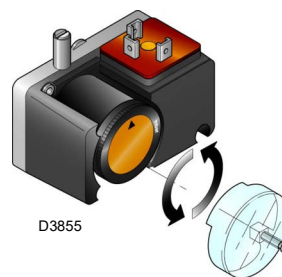

Fig. 39

**5.9.5 Oil pressure switch**

Check that the oil pressure switches have intervened correctly. Turn the adjustment screw (Fig. 40) to check that the pressure switches have intervened. The check should be carried out by individually varying the calibration of each pressure switch.

Decreasing the maximum calibration of the oil pressure switch, the burner should go into lockout.

Increasing the minimum calibration of the oil pressure switch, the burner should not start.

While the minimum oil pressure switch must be calibrated to approx. 16-18 bars.

With the control carried out, restore the factory setting of the maximum oil pressure switch to approx. 4-5 bar.

Any other pressure values should be adjusted to the burner output.

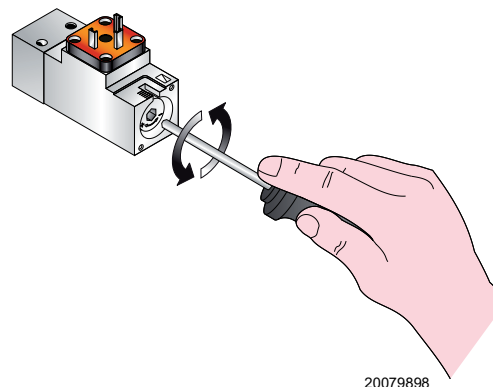

Fig. 40

**5.10 Final checks (with burner operating)**

<ul style="list-style-type: none"> <li>➤ Open the thermostat/pressure switch TL</li> <li>➤ Open the thermostat/pressure switch TS</li> </ul>	➡	The burner must stop
<ul style="list-style-type: none"> <li>➤ Turn the gas maximum pressure switch knob to the minimum end of scale position</li> <li>➤ Turn the air pressure switch to the maximum end of scale position</li> </ul>	➡	The burner must stop in lockout
<ul style="list-style-type: none"> <li>➤ Turn the oil maximum pressure switch knob to the minimum end of scale position</li> <li>➤ Turn the oil minimum pressure switch knob to the maximum end of scale position</li> </ul>	➡	The burner must stop in lockout
<ul style="list-style-type: none"> <li>➤ Turn off the burner and cut off the power</li> <li>➤ Disconnect the minimum gas pressure switch connector</li> </ul>	➡	The burner must not start
<ul style="list-style-type: none"> <li>➤ Disconnect the QRI flame sensor wire</li> </ul>	➡	The burner must stop in lockout due to ignition failure

Tab. J



Make sure that the mechanical locking systems on the various adjustment devices are fully tightened.

**6 Maintenance**

**6.1 Notes on safety for the maintenance**

The periodic maintenance is essential for the good operation, safety, yield and duration of the burner.

It allows you to reduce consumption and polluting emissions and to keep the product in a reliable state over time.



The maintenance interventions and the calibration of the burner must only be carried out by qualified, authorised personnel, in accordance with the contents of this manual and in compliance with the standards and regulations of current laws.

Before carrying out any maintenance, cleaning or checking operations:



Turn off the burner's electrical supply using the main system switch.



Turn off the fuel interception tap.



Wait for the components in contact with heat sources to cool down completely.

**6.2 Maintenance programme**

**6.2.1 Maintenance frequency**



The gas combustion system should be checked at least once a year by a representative of the manufacturer or another specialised technician.

**6.2.2 Safety test - with no gas supply**

To perform commissioning in safety conditions, it is very important to check correct wiring between gas valves and burner.

For this purpose, after checking that connections comply with the burner wiring diagrams, it is necessary to carry out a start-up cycle with gas cock closed (dry test).

- 1 The manual gas valve must be closed using the locking/unlocking device ("Lock-out / tag out" procedure).
- 2 Ensure that burner limit electrical contacts are closed
- 3 Ensure that minimum gas pressure switch contact is closed
- 4 Try to start the burner.

The start-up cycle must occur according to the following steps:

- Fan motor start-up for pre-purging
- Gas valve leak detection control, if applicable.
- Pre-purging completion
- Achievement of the ignition point
- Power supply of the ignition transformer
- Supply of gas valves.

As gas is closed, the burner cannot ignite and its flame control will switch to stop or safety lockout condition.

The actual supply of gas valves can be checked by inserting a tester; some valves are equipped with lights (or closing/opening position indicators) that activate as soon as they are powered.



**IF POWER SUPPLY OF GAS VALVES OCCURS IN UNEXPECTED MOMENTS, DO NOT OPEN THE MANUAL VALVE, DISCONNECT POWER SUPPLY, CHECK WIRINGS, CORRECT THE ERRORS AND CARRY OUT THE WHOLE TEST AGAIN.**

**6.2.3 Checking and cleaning**



The operator must use the required equipment during maintenance.

**Combustion**

The optimum calibration of the burner requires an analysis of the flue gases.

Significant differences with respect to the previous measurements indicate the points where most care should be exercised during maintenance.

**Combustion head**

Open the burner and make sure that all components of the combustion head are in good condition, not deformed by the high temperatures, free of impurities from the surroundings and correctly positioned.

**Burner**

Clean the outside of the burner.

**Fan**

Check to make sure that no dust has accumulated inside the fan or on its impellers, as this condition will cause a reduction in the air flow rate and provoke polluting combustion.

**Boiler**

Clean the boiler as indicated in its accompanying instructions in order to maintain all the original combustion characteristics intact, especially: the flue gas temperature and combustion chamber pressure.

**Voltage on the QRI flame sensor**

Min value for a good work: 3.5V DC (value on AZL display at about 50%).

If the value is lower, it could be due to:

- sensor not positioned correctly
- low voltage (lower than 187 V)
- bad regulation of the burner

In order to measure, use a voltmeter with a 10V DC scale connected as in the diagram (Fig. 41).

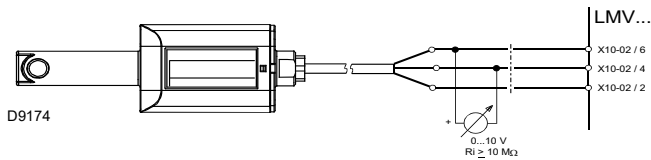

Fig. 41

**Fuel tank**

Approximately every 5 years, suck any water on the bottom of the tank using a separate pump.

**Combustion**

In case the combustion values found at the beginning of the intervention do not respect the standards in force or, in any case, do not correspond to a proper combustion, contact the Technical Assistance Service in order to carry out the necessary adjustments.

EN 267	Air excess		CO
	Max. output $\lambda \leq 1.2$	Min. output $\lambda \leq 1.3$	
Theoretical max CO <sub>2</sub> 0 % O <sub>2</sub>	CO <sub>2</sub> % Calibration		mg/kWh
	$\lambda = 1.2$	$\lambda = 1.3$	
15.2	12.6	11.5	≤ 100

Tab. K

**LIGHT OIL OPERATION**

**Pump**

The delivery pressure must be 25 bar.

The depression must be less than 0.45 bar.

Unusual noise must not be evident during pump operation.

If the pressure is found to be unstable or if the pump runs noisily, the flexible hose must be detached from the line filter and the fuel must be sucked from a tank located near the burner. This measure permits the cause of the anomaly to be traced to either the suction piping or the pump. If the problem lies in the suction line, check the filter is clean and that air is not entering the piping.

**Filters (Fig. 42)**

Check the filtering baskets on line 1) and at nozzle 2) present in the system. Clean or replace if necessary. If rust or other impurities are observed inside the pump, use a separate pump to lift any water and other impurities that may have deposited on the bottom of the tank.

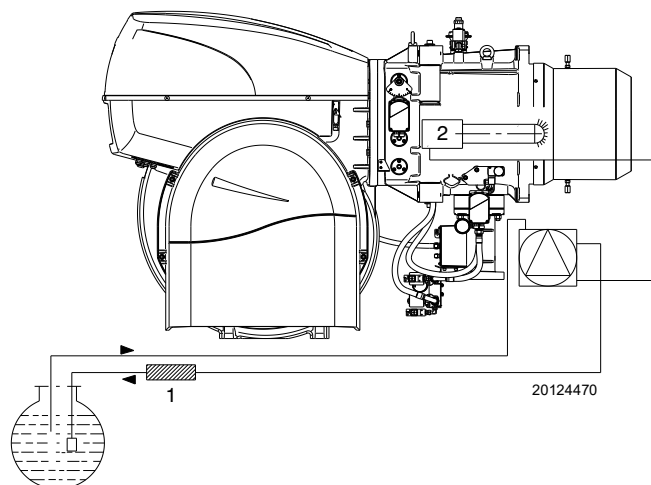

Fig. 42

**Nozzles**

It is advisable to replace nozzles once a year during periodical maintenance.

Do not clean the nozzle openings.

**Hoses**

Check that these are in good conditions.

**GAS OPERATION**

**Gas leaks**

Make sure that there are no gas leaks on the pipe between the gas meter and the burner.

**Gas filter**

Change the gas filter when it is dirty.

**Combustion**

In case the combustion values found at the beginning of the intervention do not respect the standards in force or, in any case, do not correspond to a proper combustion, contact the Technical Assistance Service in order to carry out the necessary adjustments.

EN 676	GAS	Theoretical max CO <sub>2</sub> 0 % O <sub>2</sub>	Air excess		CO
			Max. output $\lambda \leq 1.2$	Max. output $\lambda \leq 1.3$	
			CO <sub>2</sub> % Calibration		mg/kWh
			$\lambda = 1.2$	$\lambda = 1.3$	
	G 20	11.7	9.7	9	≤ 100
	G 25	11.5	9.5	8.8	≤ 100
	G 30	14.0	11.6	10.7	≤ 100
	G 31	13.7	11.4	10.5	≤ 100

Tab. L

### 6.2.4 Electrical panel



Turn off the burner's electrical supply using the main system switch.

In the event of maintenance/replacement of components in the lower part of the electrical panel, access is possible via the front of the panel itself, following the directions below:

- unscrew the screws 2) of the control panel 1);
- extract the control panel 1) and turn it 90°, hooking it with the brackets 3) in the profile of the electrical panel as shown in Fig. 43;
- after performing the operation, install the control panel 1) in the electrical panel with the appropriate screws 2), arranging the cables present.



Failure to install the control panel 1) in the seat of the electrical panel, results in the machine's loss of "IP" protection.

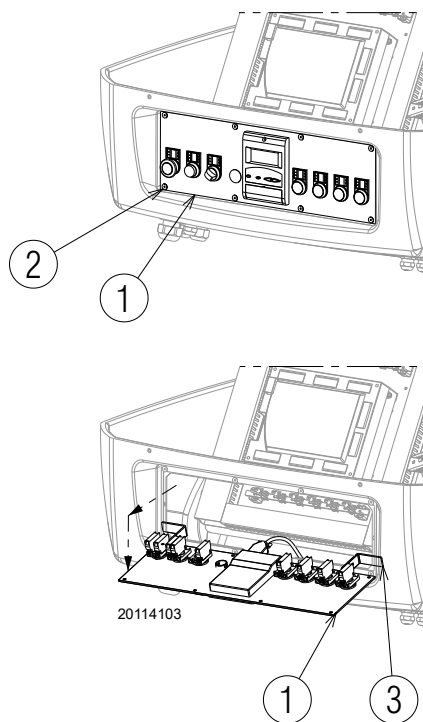

Fig. 43

### 6.3 Checking the position of the rpm sensor

To calibrate the rpm sensor 6)(Fig. 44), proceed as follows:

- remove the cover 1) unscrewing the screws 2);
- unscrew or screw the nuts 3) - 5) and the rpm detection disc 4) so that its distance from the rpm sensor 6) is about 2 mm.;
- place the plate 4) on the nut 5) and fix with the lock nut 3);
- close the cover 1) by screwing the screws 2).

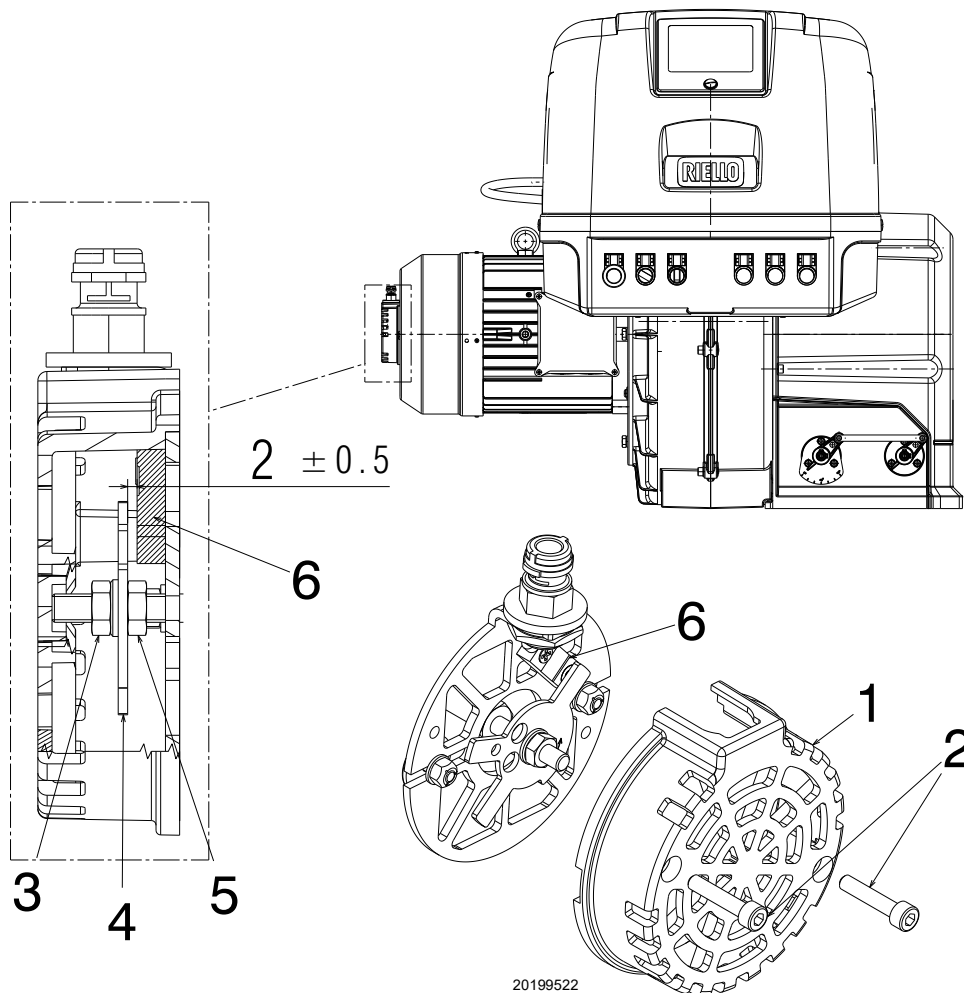

Fig. 44

Key (Fig. 44)

- 1 Cover
- 2 Screws for cover fixing
- 3 Lock nut
- 4 Rpm detection disc
- 5 Lower nut
- 6 Rpm sensor

### 6.3.1 Safety components

The safety components should be replaced at the end of their life cycle indicated in the following table.

The specified life cycles do not refer to the warranty terms indicated in the delivery or payment conditions.

Safety component	Life cycle
Flame control	10 years or 250.000 operation cycles
Flame sensor	10 years or 250.000 operation cycles
Gas valves (solenoid)	10 years or 250.000 operation cycles
Pressure switches	10 years or 250.000 operation cycles
Pressure adjuster	15 years
Servomotor (electronic cam) (if present)	10 years or 250.000 operation cycles
Oil valve (solenoid) (if present)	10 years or 250.000 operation cycles
Oil regulator (if present)	10 years or 250.000 operation cycles
Oil pipes/couplings (metallic) (if present)	10 years
Fan impeller	10 years or 500.000 start-ups

Tab. M

### 6.3.2 Pump unit



**WARNING**

Prior to performing any operations/maintenance on the pump unit, make sure the electrical power supply to the burner is turned off by means of the system's main switch.

## 6.4 Opening the burner



DANGER

Turn off the burner's electrical supply using the main system switch.



DANGER

Turn off the fuel interception tap.



Wait for the components in contact with heat sources to cool down completely.

- Disconnect the socket 1) of the oil/gas servomotor;
- disconnect the socket of the derivation unit.
- disconnect the flame sensor socket
- disconnect the electrode connection from the transformer, see procedure in chapter 4.9 "Access to head internal part";
- remove the screws 2). At this point, it is possible to open the burner on the hinge.

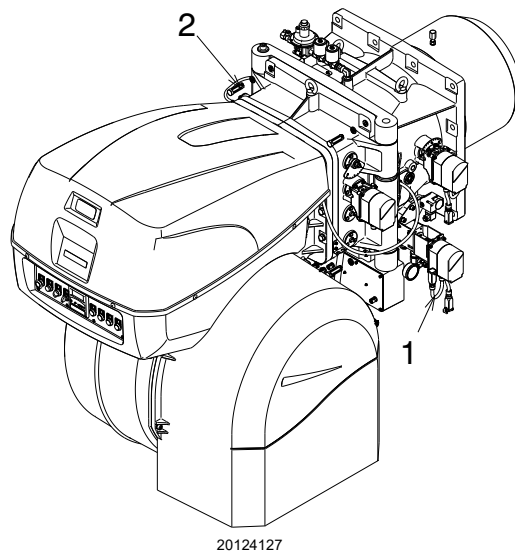

Fig. 45

## 6.5 Closing the burner

Refit following the steps described but in reverse order; refit all burner components as they were originally assembled.



After carrying out maintenance, cleaning or checking operations, reassemble the cover and all the safety and protection devices of the burner.

**7** **Faults - Probable causes - Solutions**

If faults arise in ignition or operations, the burner performs a "safety stop", which is signalled by the red burner lockout LED.

The display visualises alternately the lockout code and the relative diagnostic. To reset the start-up conditions, refer to the "Reset procedure" indicated in the flame control manual supplied.

When the burner starts again, the red LED goes out and the flame control is reset.

**WARNING**

In the event the burner stops, in order to prevent any damage to the installation, do not unblock the burner more than twice in a row. If the burner locks out for a third time, contact the customer service.

**DANGER**

In the event there are further lockouts or faults with the burner, the maintenance interventions must only be carried out by qualified, authorised personnel, in accordance with the contents of this manual and in compliance with the standards and regulations of current laws.

## A Appendix - Accessories

### Kit Inverter (VSD)

Burner	Power Supply	Inverter Output	Code
RLS 1600/EV C11	3Ph/400V/50Hz	37 kW	20095475
RLS 2000/EV C11	3Ph/400V/50Hz	45 kW	20095476



**WARNING**

The use of inverters other than those indicated by the manufacturer may lead to burner failure and, in extreme cases, a potential risk of harm to people and damage to property.

The manufacturing company shall not be liable for any such damage arising from non-observance of the requirements contained in this manual.

### Air/combustion fume temperature sensor

Parameter to be checked		Probe	
	Adjustment field	Type	Code
Temperature	- 100...+ 500°C	PT 1000Ni1000	3010377

### Pump unit flame control

Model	Fuel	Connection	Output at 30 bar	Motor (kW)	Burner max. output (kg/h)	Code
SG 1000	Light oil	1"	2200 l/h (*)	4	900	20097693
SG 1250	Light oil	1"	3000 l/h (*)	4	1250	20098501
SG 1500	Light oil	1"	3600 l/h (*)	5.5	1500	20097701
SG 2000	Light oil	1"	4800 l/h (*)	7.5	2000	20097703

### AZL Kit (display and operating unit) - (Russia only)

Burner	Code
All models	3010469

### Pressure switch kit for leak detection control (supplied as standard)

Burner	Code
All models	3010344

### Software interface kit

Burner	Code
All models	3010388

### Kit O<sub>2</sub>

Burner	Code
All models	20045187

### Flue gases sensor bracket kit

Burner	Code
All models	20041585

### Gas trains in compliance with EN 676

Please refer to manual.

**B Appendix - Electrical panel layout**

<b>1</b>	<b>Index of layouts</b>
<b>2</b>	Indication of references
<b>3</b>	Single-wire output layout
<b>4</b>	Fuel selection functional layout
<b>5</b>	LMV52.... functional layout
<b>6</b>	LMV52.... functional layout
<b>7</b>	LMV52.... functional layout
<b>8</b>	LMV52.... functional layout
<b>9</b>	LMV52.... functional layout
<b>10</b>	LMV52.... functional layout
<b>11</b>	LMV52.... functional layout
<b>12</b>	LMV52.... functional layout
<b>13</b>	Electrical wiring that the installer is responsible for
<b>14</b>	Electrical wiring that the installer is responsible for
<b>15</b>	Electrical wiring that the installer is responsible for

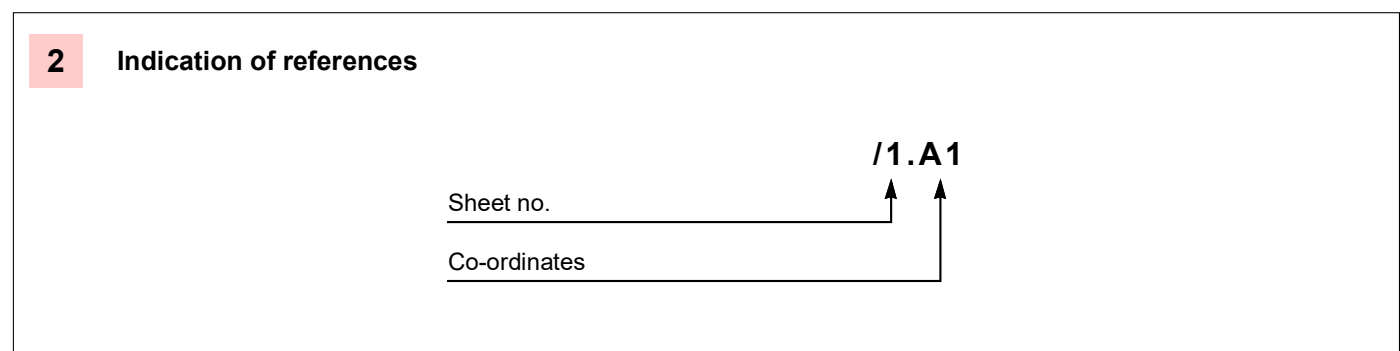

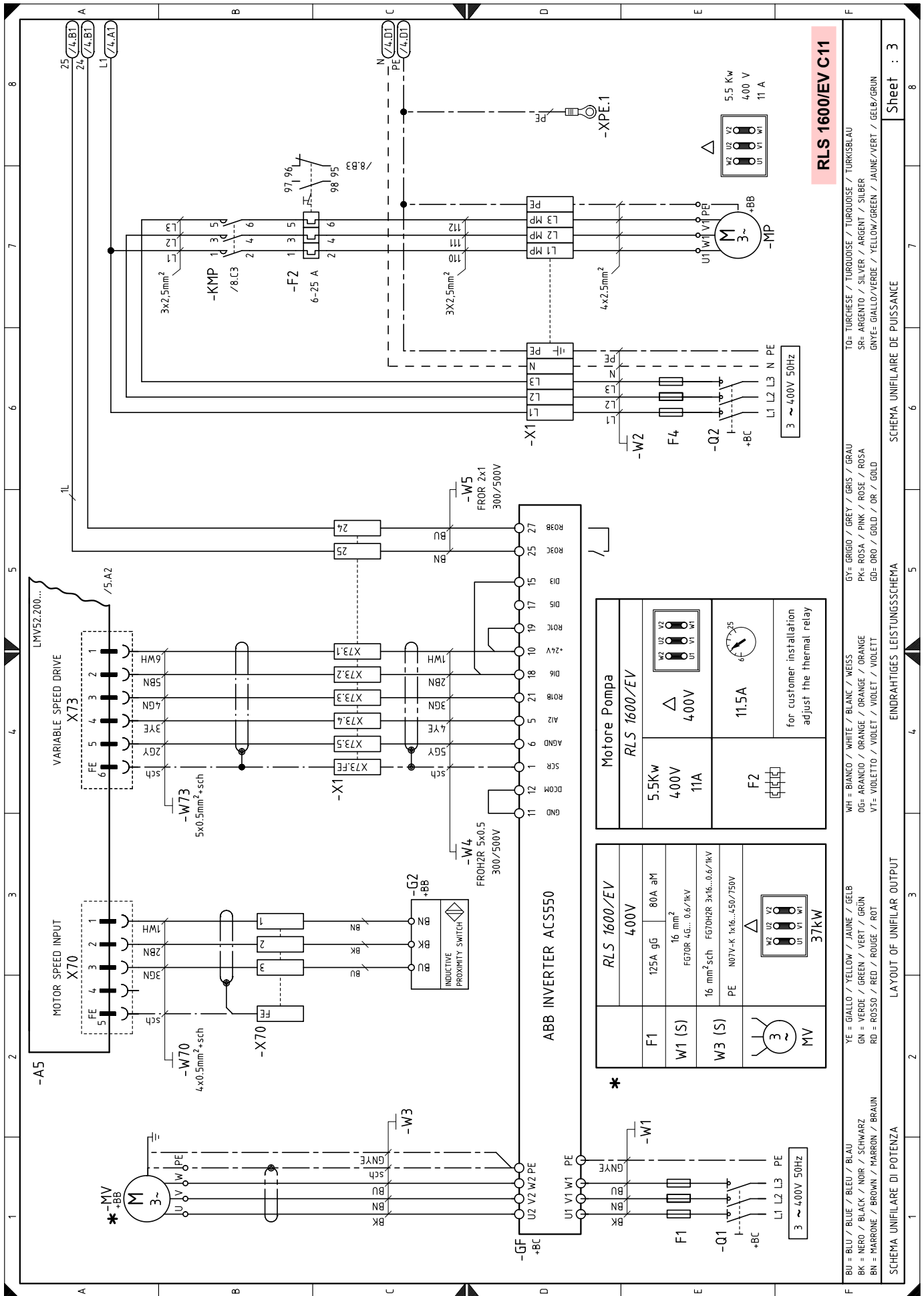

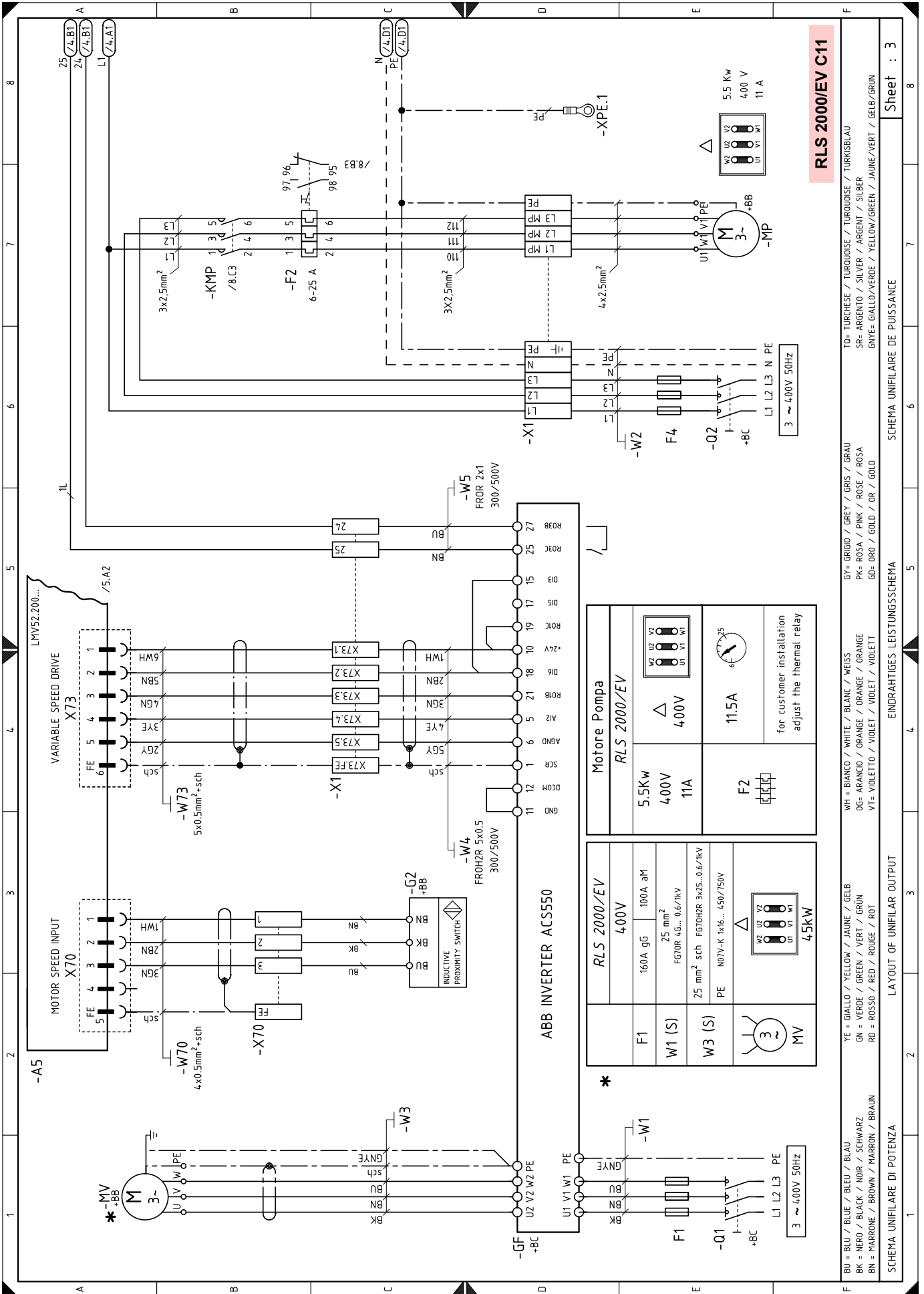

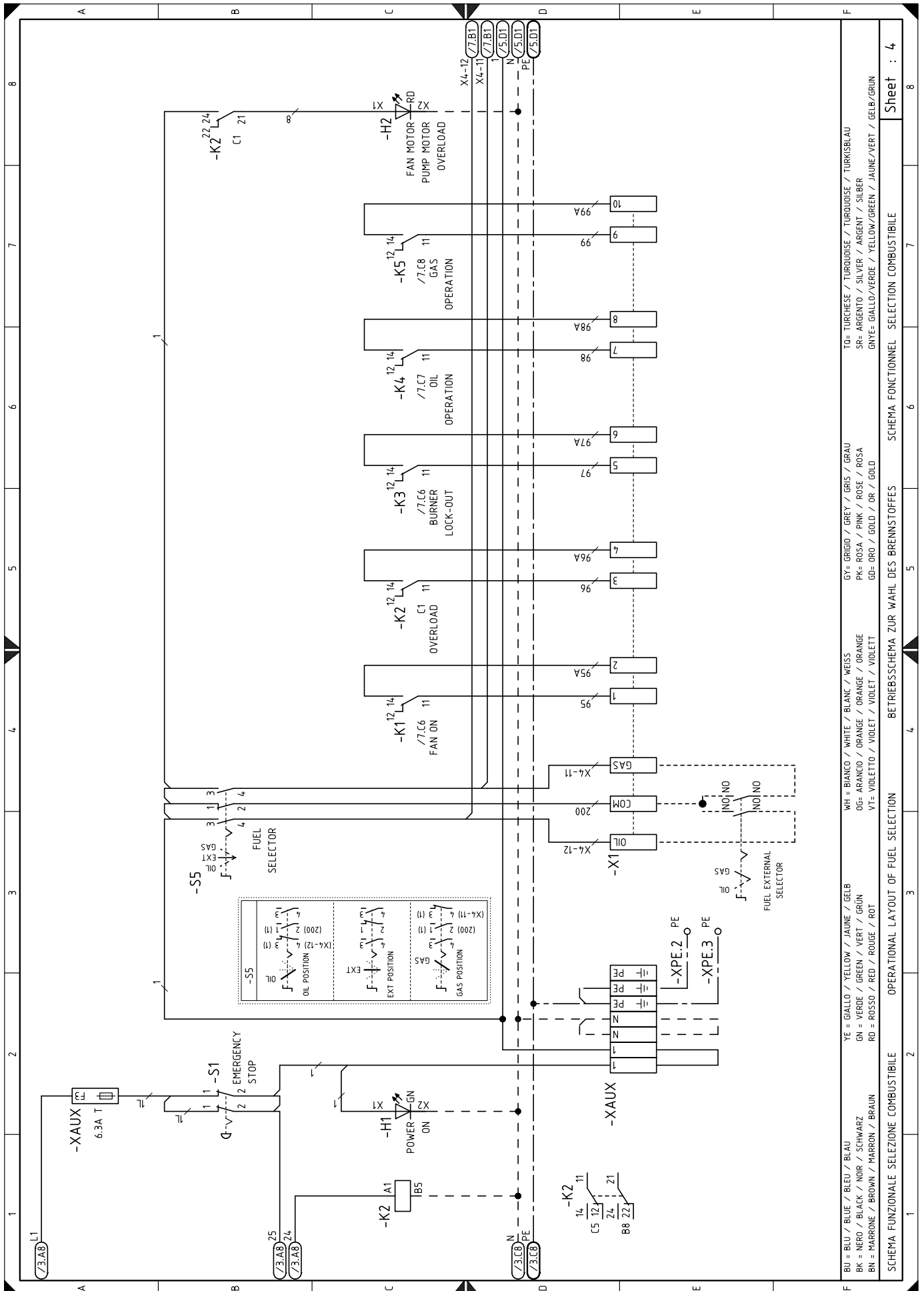

TO= TURCHESE / TURQUOISE / TURQUOISE / TURQUOISE / TURKISBLAU  
 SR= ARGENTO / SILVER / ARGENT / SILBER  
 GN= GIALLO/VERDE / YELLOW/GREEN / JAUNE/VERT / GELB/GRÜN

WH = BIANCO / WHITE / BLANC / WEISS  
 OR= ARANCIO / ORANGE / ORANGE / ORANGE  
 VI= VIOLETTO / VIOLET / VIOLET / VIOLETT

GY= GRIGIO / GREY / GRIS / GRAU  
 PK= ROSA / PINK / ROSE / ROSA  
 GD= ORO / GOLD / OR / GOLD

YE = GIALLO / YELLOW / JAUNE / GELB  
 GN = VERDE / GREEN / VERT / GRÜN  
 RD = ROSSO / RED / ROUGE / ROT

BU = BLU / BLUE / BLEU / BLAU  
 BK = NERO / BLACK / NOIR / SCHWARZ  
 BN = MARRONE / BROWN / MARRON / BRAUN

SCHEMA FUNZIONALE SELEZIONE COMBUSTIBILE  
 SCHEMA FUNCTIONNEL SELECTION COMBUSTIBLE  
 SCHEMA FUNKTIONELL SELEKTION COMBUSTIBEL

Sheet : 4

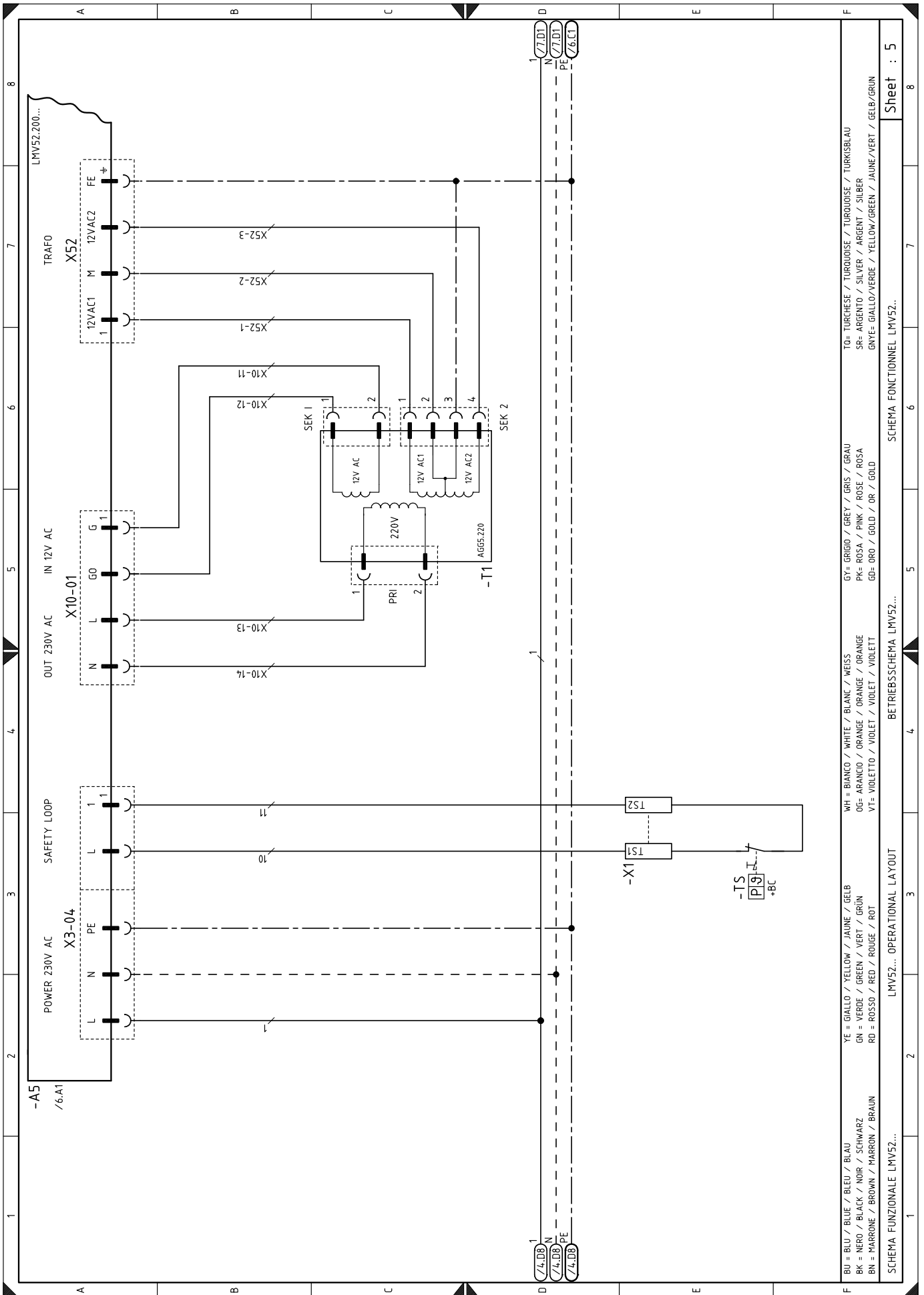

BU = BLU / BLUE / BLEU / BLAU  
 BK = NERO / BLACK / NOIR / SCHWARZ  
 BN = MARRONE / BROWN / MARRON / BRAUN  
 YE = GIALLO / YELLOW / JAUNE / GÉLBE  
 GN = VERDE / GREEN / VERT / GRÜN  
 RD = ROSSO / RED / ROUGE / ROT  
 WH = BIANCO / WHITE / BLANC / WEISS  
 OG= ARANCIO / ORANGE / ORANGE / ORANGE  
 VT= VIOLETT / VIOLET / VIOLET / VIOLETT  
 GY= GRIGIO / GREY / GRIS / GRAU  
 PK= ROSA / PINK / ROSE / ROSA  
 GO= ORO / GOLD / OR / GOLD  
 TO= TURCHESE / TURQUOISE / TURQUOISE / TURKISBLAU  
 SR= ARGENTO / SILVER / ARGENT / SILBER  
 GNYE= GIALLO/VERDE / YELLOW/GREEN / JAUNE/VERT / GELB/GRÜN

Sheet : 5

BETRIEBSSCHEMA LMV52...

OPERATIONAL LAYOUT

SCHEMA FUNZIONALE LMV52...

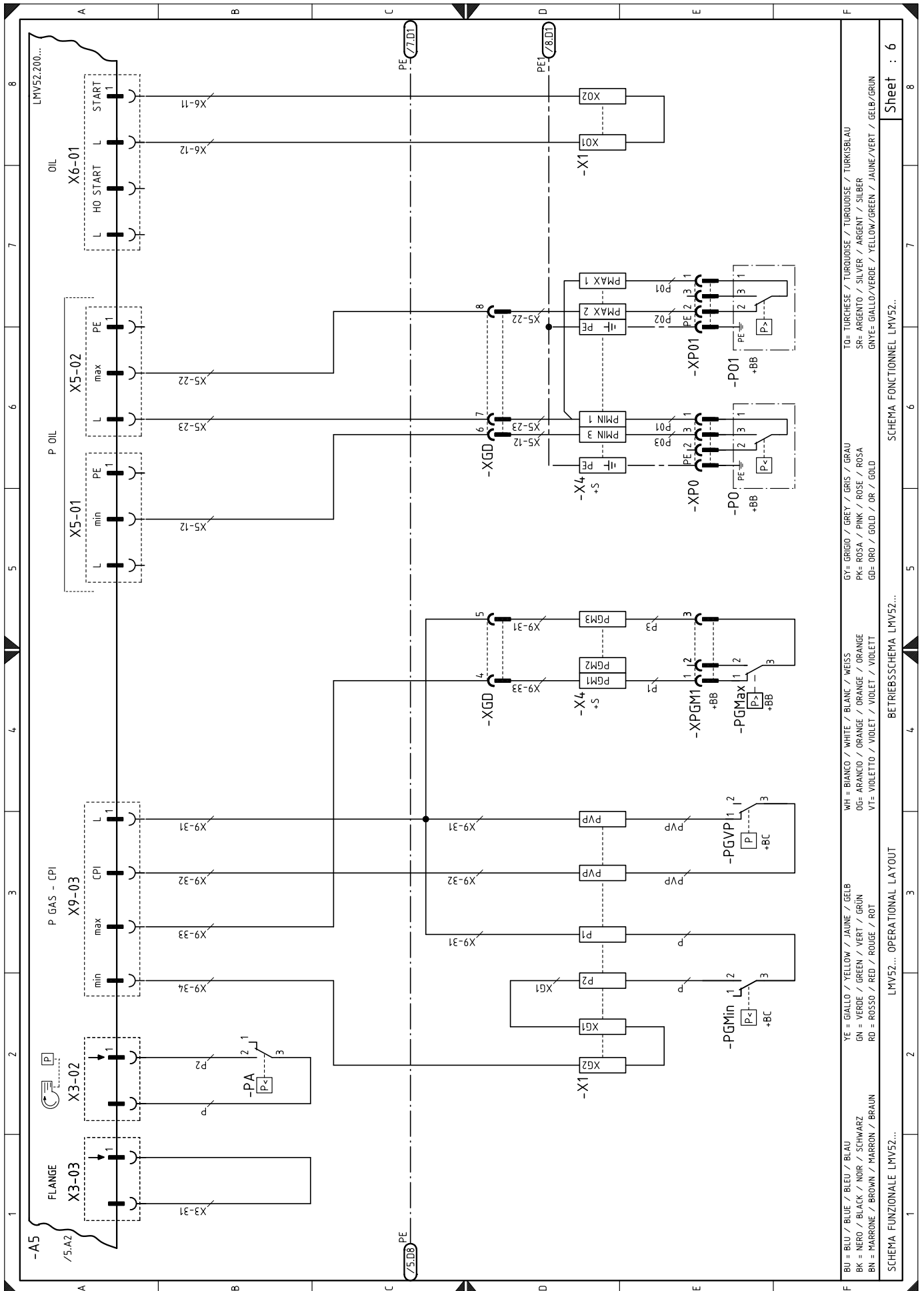

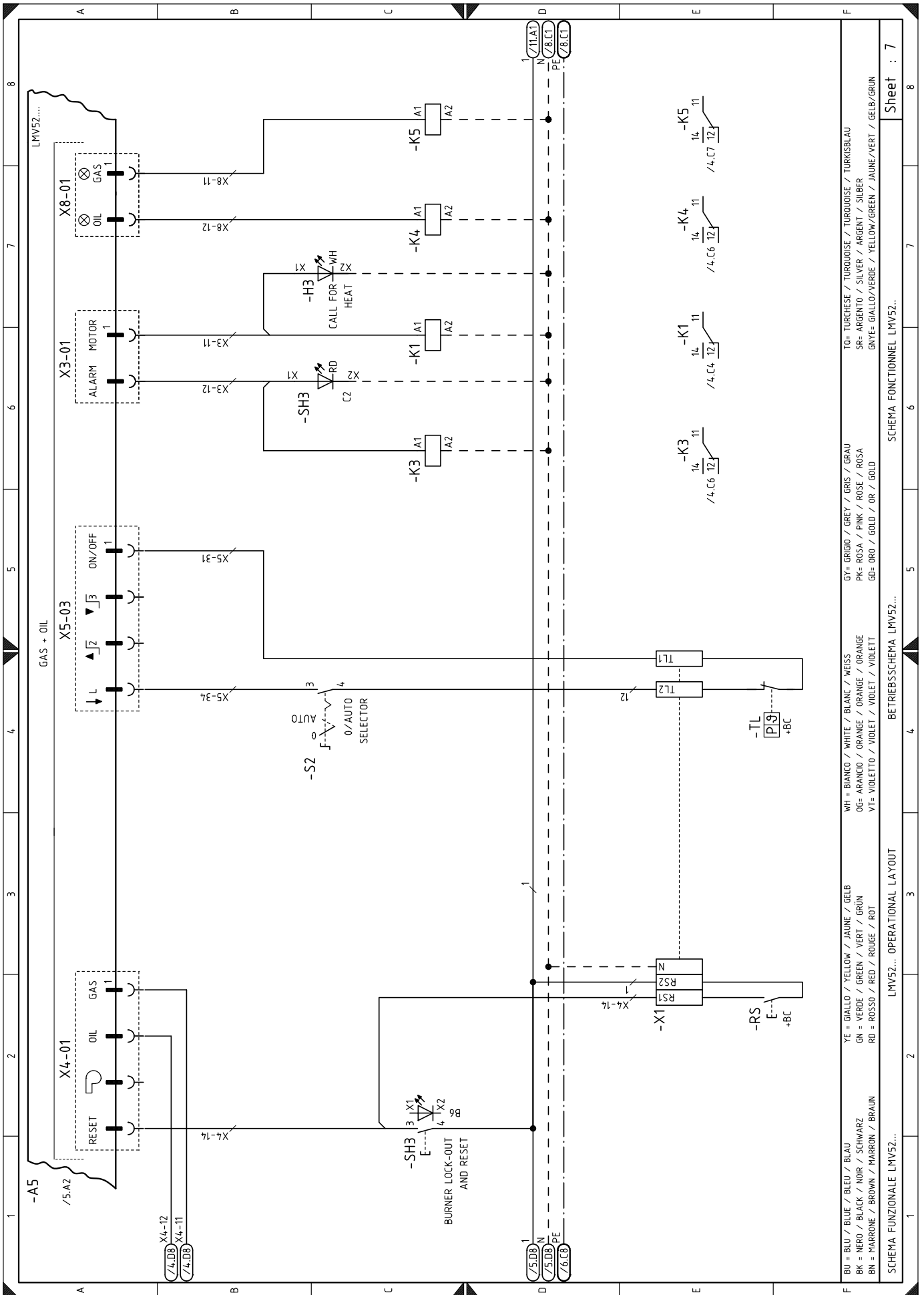

Sheet : 7

TO= TURCHESE / TURKOISE / TURQUOISE / TURKISBLAU  
 SR= ARGENTO / SILVER / ARGENT / SILBER  
 GN= GIALLO/VERDE / YELLOW/GREEN / JAUNE/VERT / GELB/GRUN  
 GY= GRIGIO / GREY / GRIS / GRAU  
 PK= ROSA / PINK / ROSE / ROSA  
 GD= ORO / GOLD / OR / GOLD  
 WH= BIANCO / WHITE / BLANC / WEISS  
 OG= ARANCIO / ORANGE / ORANGE / ORANGE  
 VT= VIOLETTO / VIOLET / VIOLET / VIOLETT  
 YE= GIALLO / YELLOW / JAUNE / GELB  
 GN= VERDE / GREEN / VERT / GRUN  
 RD= ROSSO / RED / ROUGE / ROT  
 BK= NERO / BLACK / NOIR / SCHWARZ  
 BN= MARRONE / BROWN / MARRON / BRAUN

SCHEMA FUNZIONALE LMV52...

OPERATIONAL LAYOUT

SCHEMA FUNZIONALE LMV52...



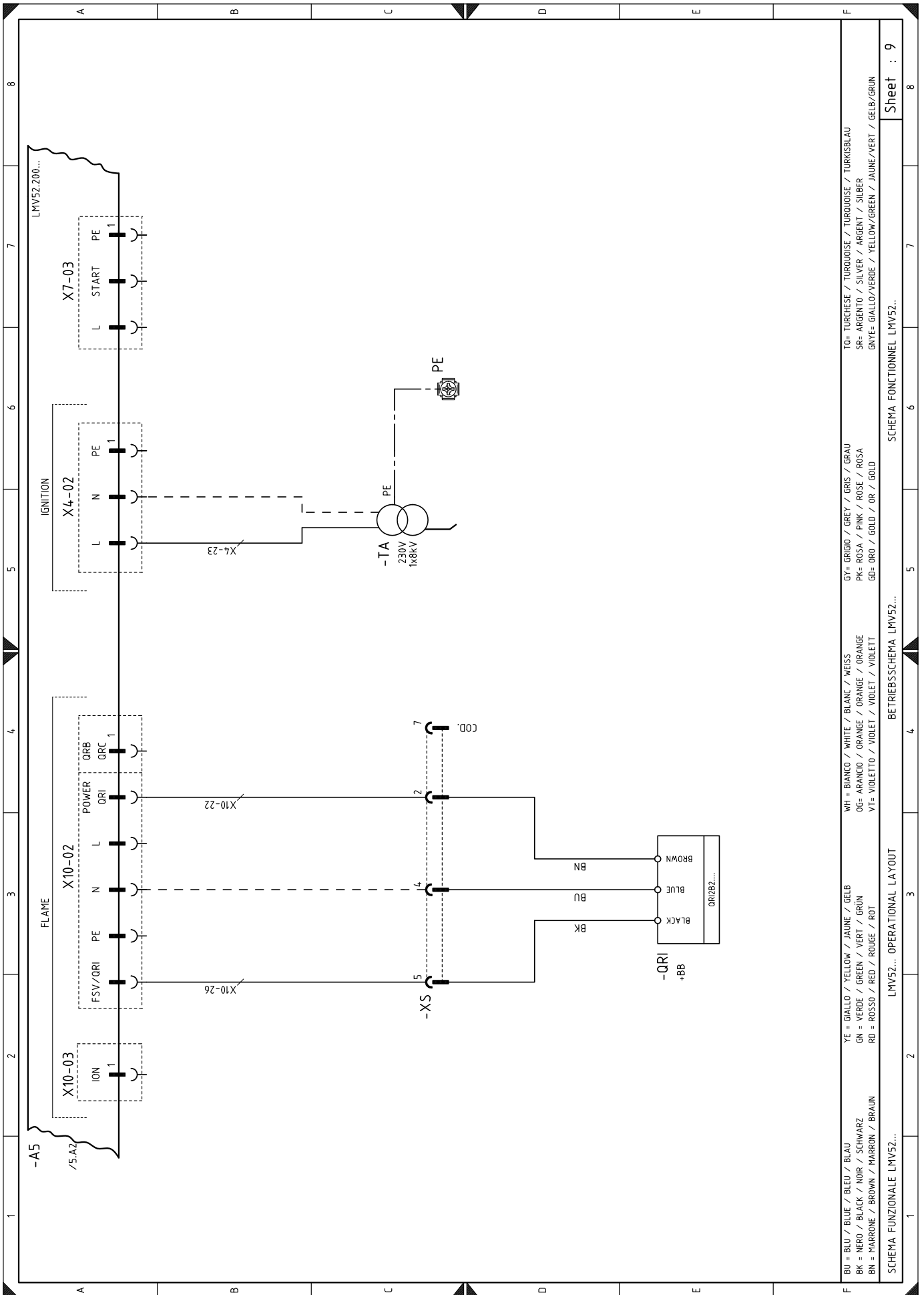

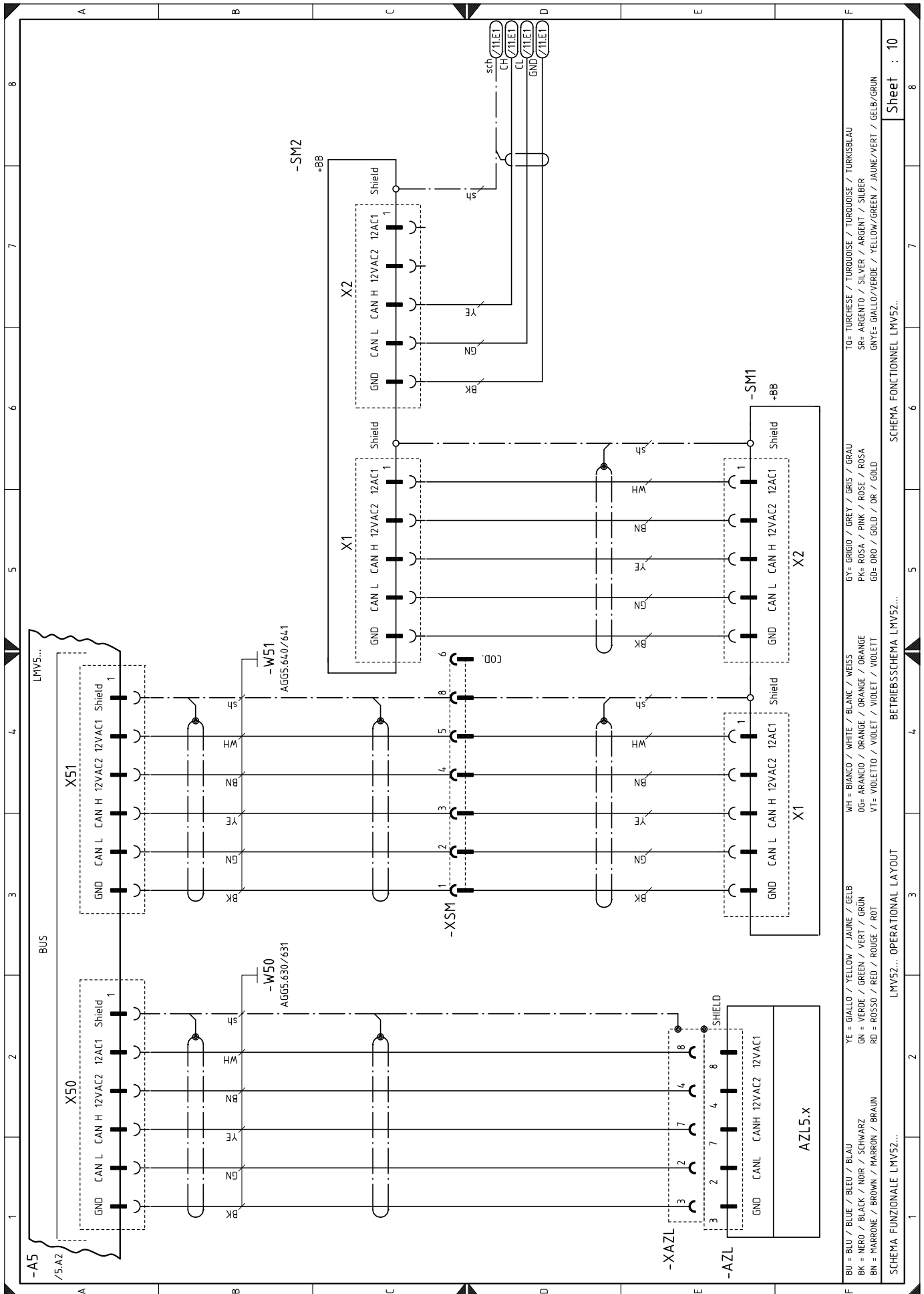

TO= TURCHESE / TURQUOISE / TURQUOISE / TURQUOISE / TURKISBLAU  
 SR= ARGENTO / SILVER / ARGENT / SILBER  
 GNYE= GIALLO/VERDE / YELLOW/GREEN / JAUNE/VERT / GELB/GRÜN

GY= GRIGIO / GREY / GRIS / GRAU  
 PK= ROSA / PINK / ROSE / ROSA  
 GD= ORO / GOLD / OR / GOLD

WH = BIANCO / WHITE / BLANC / WEISS  
 O= ARANCIO / ORANGE / ORANGE / ORANGE  
 V= VIOLETTO / VIOLET / VIOLET / VIOLETT

YE = GIALLO / YELLOW / JAUNE / GELB  
 GN = VERDE / GREEN / VERT / GRÜN  
 RD = ROSSO / RED / ROUGE / ROT

BU = BLU / BLUE / BLEU / BLAU  
 BK = NERO / BLACK / NOIR / SCHWARZ  
 BN = MARRONE / BROWN / MARRON / BRAUN

LMV52... OPERATIONAL LAYOUT  
 LMV52... SCHEMA FONCTIONNEL LMV52...

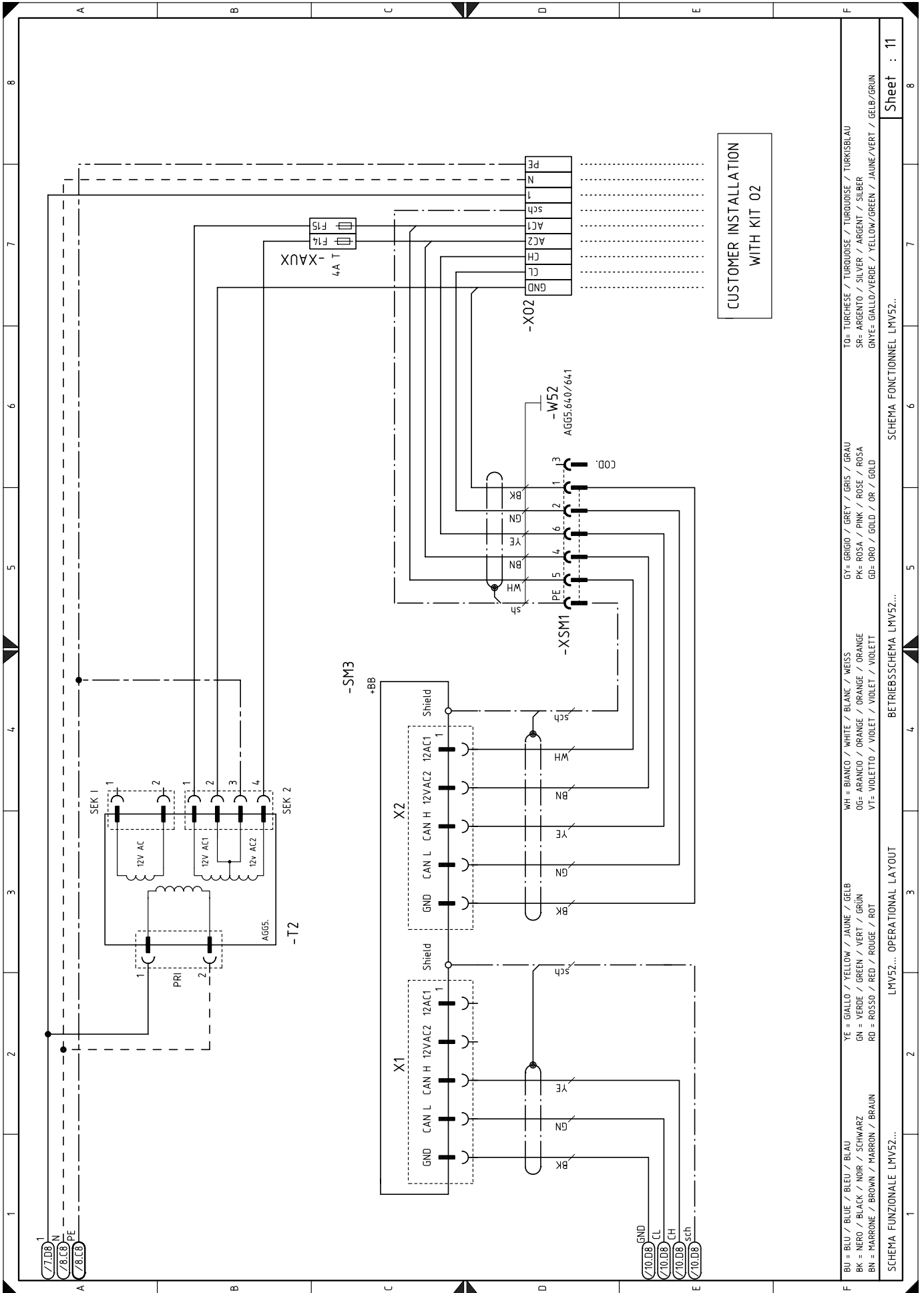



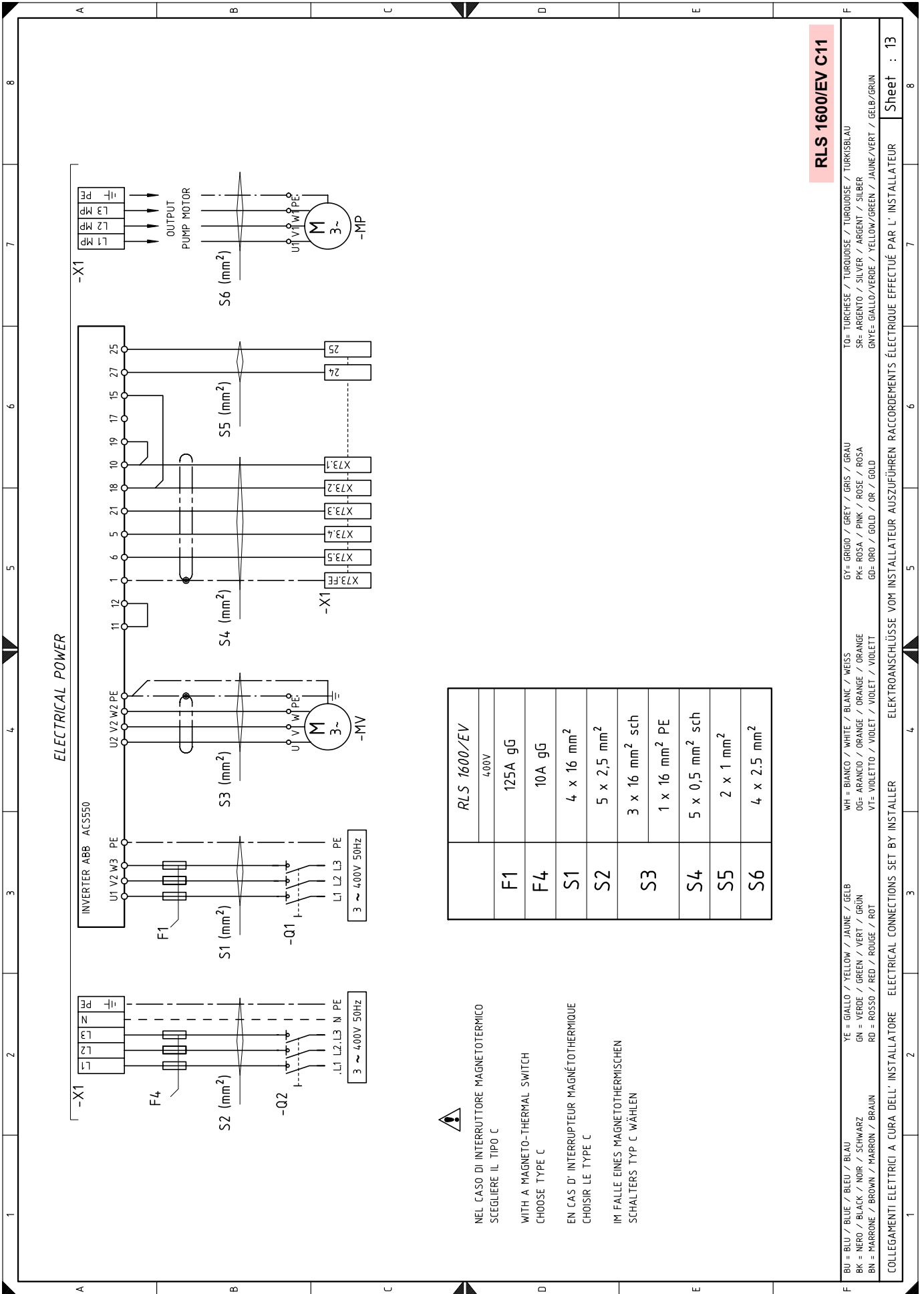

NEL CASO DI INTERRUPTORE MAGNETOTERMICO  
SCEGLIERE IL TIPO C

WITH A MAGNETO-THERMAL SWITCH  
CHOOSE TYPE C

EN CAS D'INTERRUPTEUR MAGNÉOTHERMIQUE  
CHOISIR LE TYPE C

IM FALLE EINES MAGNETOTHERMISCHEN  
SCHALTERS TYP C WÄHLEN

	RLS 1600/EV
	400V
F1	125A gG
F4	10A gG
S1	4 x 16 mm <sup>2</sup>
S2	5 x 2,5 mm <sup>2</sup>
S3	3 x 16 mm <sup>2</sup> sch 1 x 16 mm <sup>2</sup> PE
S4	5 x 0,5 mm <sup>2</sup> sch
S5	2 x 1 mm <sup>2</sup>
S6	4 x 2,5 mm <sup>2</sup>

**RLS 1600/EV C11**

F BU = BLU / BLUE / BLEU / BLAU YE = GIALLO / YELLOW / JAUNE / GÉLB WH = BIANCO / WHITE / BLANC / WEISS GY= GRIGIO / GREY / GRIS / GRAU TO= TURCHESE / TURKOISE / TURKOISE / TÜRKISBLAU  
BK = NERO / BLACK / NOIR / SCHWARZ GN = VERDE / GREEN / VERT / GRÜN OG= ARANCIO / ORANGE / ORANGE / ORANGE PK= ROSA / PINK / ROSE / ROSA SR= ARGENTO / SILVER / ARGENT / SILBER  
BN = MARRONE / BROWN / MARRON / BRAUN RT = ROSSO / RED / ROUGE / ROT VT= VIOLETT / VIOLET / VIOLET / VIOLETT  
GNYE= GIALLO/VERDE / YELLOW/GREEN / JAUNE/VERT / GELB/GRÜN

COLLEGAMENTI ELETTRICI A CURA DELL'INSTALLATORE ELECTRICAL CONNECTIONS SET BY INSTALLER ELEKTROANSCHLÜSSE VOM INSTALLATEUR AUSZUFÜHREN RACCORDEMENTS ÉLECTRIQUE EFFECTUÉ PAR L'INSTALLATEUR

Sheet : 13



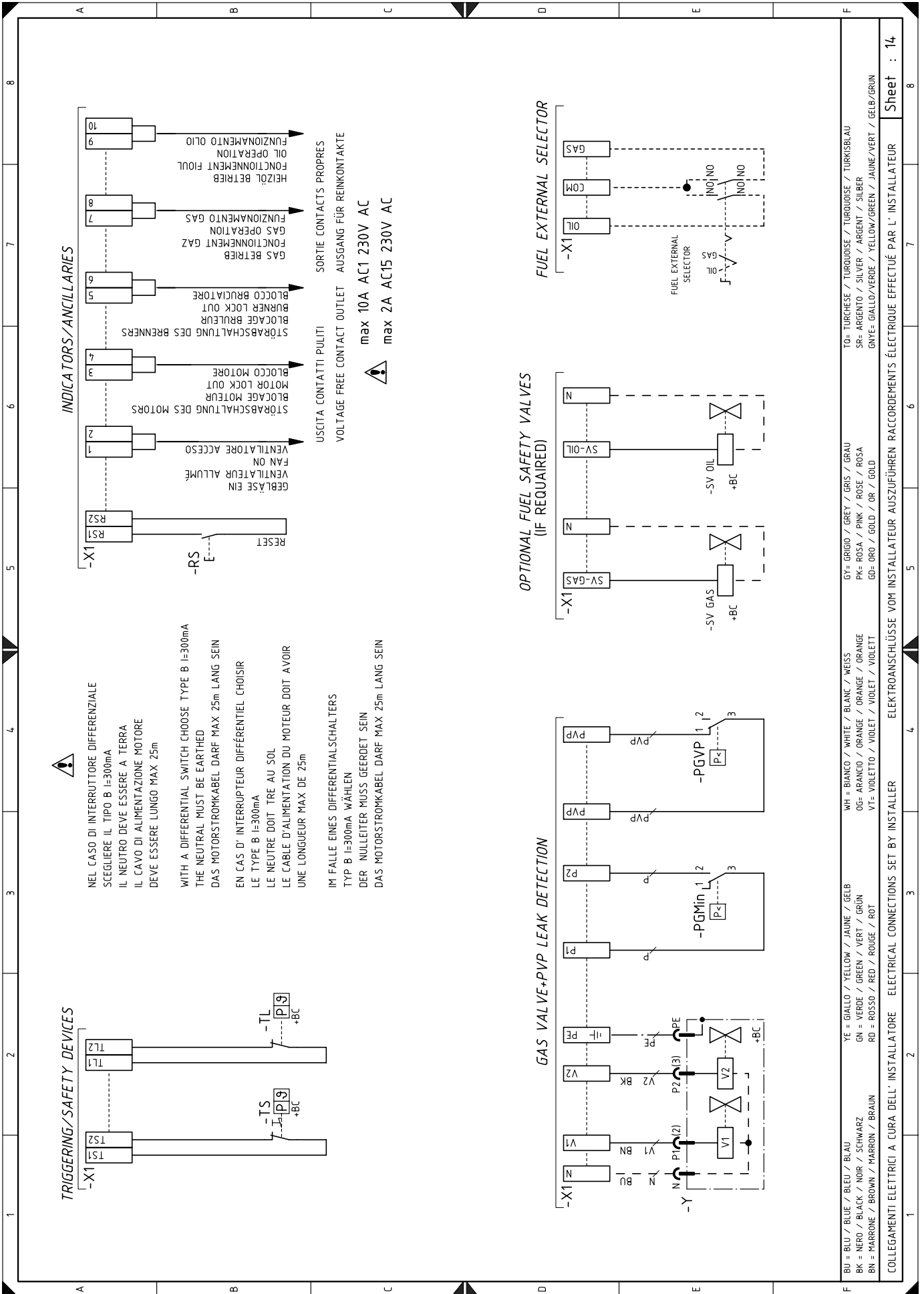

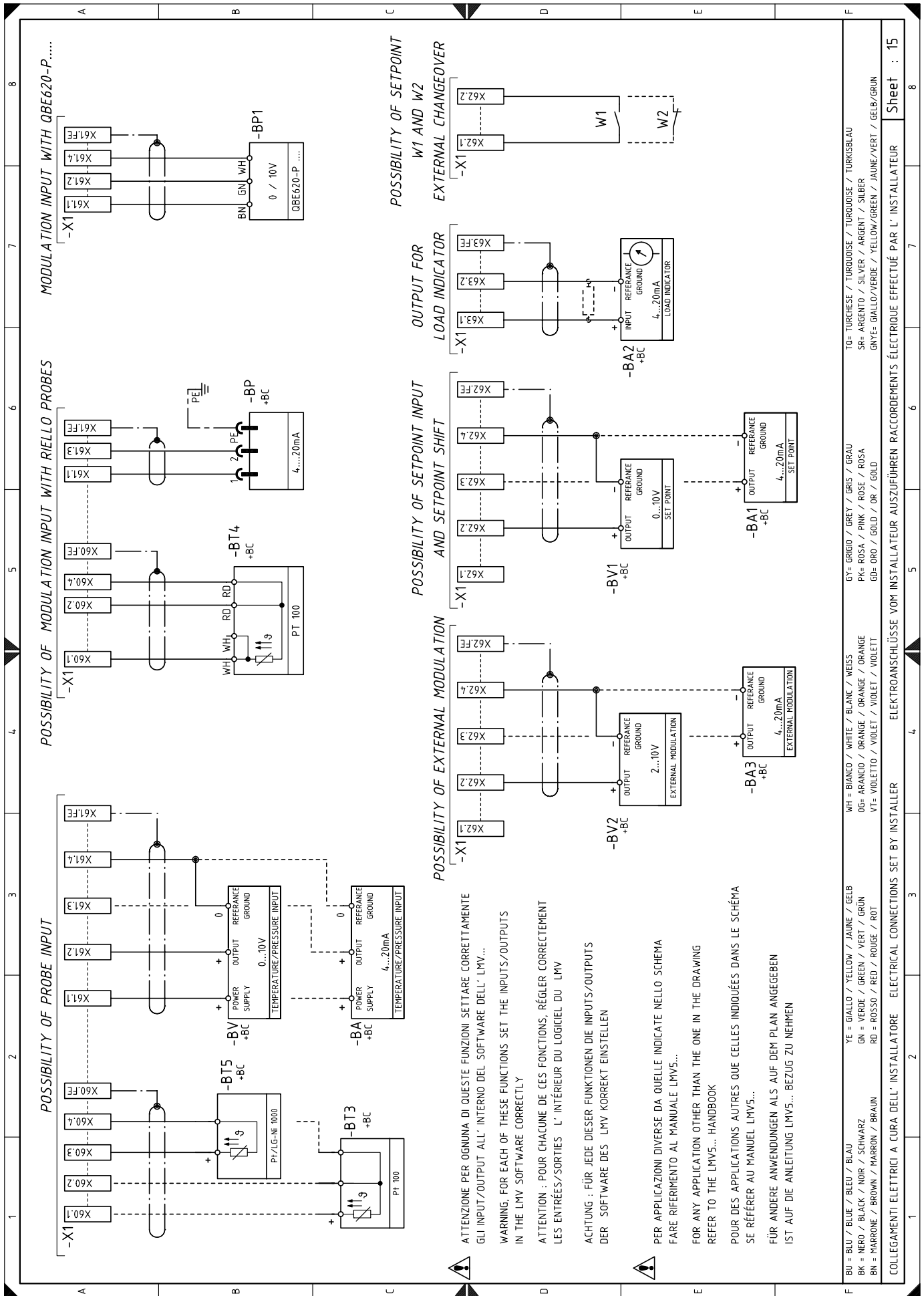

POSSIBILITY OF SETPOINT  
W1 AND W2  
EXTERNAL CHANGEOVER

OUTPUT FOR  
LOAD INDICATOR

POSSIBILITY OF SETPOINT INPUT  
AND SETPOINT SHIFT

POSSIBILITY OF EXTERNAL MODULATION

ATTENZIONE PER OGNA DI QUESTE FUNZIONI SETTARE CORRETTAMENTE  
GLI INPUT/OUTPUT ALL' INTERNO DEL SOFTWARE DELL' LMV...  
WARNING, FOR EACH OF THESE FUNCTIONS SET THE INPUTS/OUTPUTS  
IN THE LMV SOFTWARE CORRECTLY

ATTENTION : POUR CHACUNE DE CES FONCTIONS, RÉGLER CORRECTEMENT  
LES ENTRÉES/SORTIES L' INTÉRIEUR DU LOGICIEL DU LMV

ACHTUNG : FÜR JEDE DIESER FUNKTIONEN DIE INPUTS/OUTPUTS  
DER SOFTWARE DES LMV KORREKT EINSTELLEN

PER APPLICAZIONI DIVERSE DA QUELLE INDICATE NELLO SCHEMA  
FARE RIFERIMENTO AL MANUALE LMV5...

FOR ANY APPLICATION OTHER THAN THE ONE IN THE DRAWING  
REFER TO THE LMV5... HANDBOOK

POUR DES APPLICATIONS AUTRES QUE CELLES INDICUÉES DANS LE SCHÉMA  
SE RÉFÉRER AU MANUEL LMV5...

FÜR ANDERE ANWENDUNGEN ALS AUF DEM PLAN ANGEGEBEN  
IST AUF DIE ANLEITUNG LMV5... BEZUG ZU NEHMEN

BU = BLU / BLUE / BLEU / BLAU  
BK = NERO / BLACK / NOIR / SCHWARZ  
BN = MARRONE / BROWN / MARRON / BRAUN  
YE = GIALLO / YELLOW / JAUNE / GELB  
GN = VERDE / GREEN / VERT / GRÜN  
RD = ROSSO / RED / ROUGE / ROT  
VF = VIOLETT / VIOLET / VIOLET / VIOLETT

WH = BIANCO / WHITE / BLANC / WEISS  
OG = ARANCIO / ORANGE / ORANGE / ORANGE  
VF = VIOLETT / VIOLET / VIOLET / VIOLETT

GY = GRIGIO / GREY / GRIS / GRAU  
PK = ROSA / PINK / ROSE / ROSA  
GD = ORO / GOLD / OR / GOLD

TO = TURCHESE / TURQUOISE / TURQUOISE / TURKISBLAU  
SR = ARGENTO / SILVER / ARGENT / SILBER  
GN YE = GIALLO / VERDE / YELLOW / GREEN / JAUNE / VERT / GELB / GRÜN

**Wiring layout key**

A5	Flame control	VR1	Light oil return valve
AZL	Display for flame control	VS	Safety light oil valve
BA	Output probe in current	XAZL	AZL display connector
BA1	Output device in current to modify remote setpoint	XAUX	Auxiliary terminal board
BA2	Load indicator with input under current	XGD	Derivation unit connector
BA3	Device with current output for remote modulation	XPGM1	Maximum gas pressure switch connector
BP	Pressure probe	XPO	Oil pressure switch connector
BP1	Pressure probe	XPO1	Oil return pressure switch connector
BT3	Probe Pt100, 3 wires	XS	Flame sensor connector
BT4	Probe Pt100, 3 wires	XSM	Servomotor connector SM1
BT5	PT 1000 probe, 2 wires	XSM1	Servomotor connector SM3
BV	Output probe in voltage	X1	Main terminal supply board
BV1	Output device in voltage to modify remote setpoint	X4	Derivation unit terminal board
BV2	Device with voltage current output for remote modulation	X02	Kit O <sub>2</sub> terminal strip
F1	Inverter line fuse	X70	RPM sensor terminal board
F2	Pump motor thermal relay	XVP1	Pilot valve 1 connector
F3	Auxiliary fuse	XVP2	Pilot valve 2 connector
F4	Three-phase line fuse	Y	Gas regulator valve + gas safety valve
F14	Fuse T2		
F15	Fuse T2		
GF	Inverter		
G2	Rpm sensor		
H1	Light signalling burner on		
H2	Light signalling fan motor and pump motor lockout		
H3	Heat request lighting signal		
H4	Fuel supply light signal		
KMP	Pump motor contact maker		
K1	Clean contacts output relay with fan motor working		
K2	Volt-free overload contacts output relay		
K3	Clean contacts output relay burner lockout		
K4	Output relay for light oil operation clean contacts		
K5	Output relay for gas operation clean contacts		
K8	Clean contacts output relay burner switched on gas		
K9	Output relay for 'light oil burner on' clean contacts		
MP	Pump motor		
MV	Fan motor		
PA	Air pressure switch		
PE	Burner earth		
PGMAX	Maximum gas pressure switch		
PGMin	Minimum gas pressure switch		
PGVP	Pilot valves gas pressure switch		
PO	Minimum oil pressure switch		
PO1	Maximum oil pressure switch on return line		
Q1	Inverter power supply disconnect switch		
Q2	Line disconnect switch		
QRI	Flame sensor		
RS	Remote burner reset button		
S1	Emergency stop button		
S2	0 / AUTO selector		
S5	Fuel selector and enable signal to remote fuel selector		
SH3	Burner reset button and lock-out signal		
SM1	Air servomotor		
SM2	Fuel servomotor		
SM3	Head movement servomotor		
SV gas	External gas safety valve		
SV oil	Remote safety light oil valve		
TA	Ignition transformer		
TL	Limit thermostat/pressure switch		
TS	Safety thermostat/pressure switch		
T1	Flame control transformer		
T2	Transformer servomotors		
VF	Light oil operation valve		
VP1	Pilot valve 1		
VP2	Pilot valve 2		
VR	Light oil return valve		



---

**RIELLO**

RIELLO S.p.A.  
I-37045 Legnago (VR)  
Tel.: +39.0442.630111  
[http:// www.riello.it](http://www.riello.it)  
[http:// www.riello.com](http://www.riello.com)