

GB Dual fuel light oil/gas burner

Modulating operation

CE

**UK
CA**

EAC

CODE	MODEL	TYPE
20081187	RLS 1300/EV C11	LS001T2



Translation of the original instructions

1	Information and general warnings.....	3
1.1	Information about the instruction manual	3
1.1.1	Introduction.....	3
1.1.2	General dangers.....	3
1.1.3	Other symbols	3
1.1.4	Delivery of the system and the instruction manual	4
1.2	Guarantee and responsibility.....	4
2	Safety and prevention.....	5
2.1	Introduction.....	5
2.2	Personnel training	5
3	Technical description of the burner	6
3.1	Burner designation	6
3.2	Models available.....	6
3.3	Burner categories - Countries of destination	6
3.4	Technical data	7
3.5	Electrical data.....	7
3.6	Maximum dimensions.....	8
3.7	Firing rates	9
3.8	Test boiler.....	9
3.9	Burner description	10
3.10	Electrical panel description.....	11
3.11	Burner equipment.....	11
3.12	AZL Display.....	12
3.13	flame control for the air/fuel ratio (LMV52...)	13
3.14	Servomotor (SQM48.4....)	15
4	Installation	16
4.1	Notes on safety for the installation	16
4.2	Handling	16
4.3	Preliminary checks	16
4.4	Operating position	17
4.5	Removing the shutter lockout screws.....	17
4.6	Preparing the boiler	17
4.6.1	Boring the boiler plate	17
4.6.2	Blast tube length.....	17
4.7	Securing the burner to the boiler	18
4.8	Access to head internal part.....	18
4.9	Nozzle installation	19
4.9.1	Recommended nozzle.....	19
4.10	Electrode position.....	20
4.11	Combustion head adjustment.....	20
4.12	Light oil supply.....	21
4.12.1	Double-pipe circuit.....	21
4.12.2	The loop circuit.....	21
4.12.3	Hydraulic connections	22
4.12.4	Hydraulic circuit diagram	22
4.12.5	Pressure variator	22
4.13	Pump	23
4.13.1	Technical data	23
4.13.2	Priming pump	23
4.14	Gas feeding	24
4.14.1	Gas feeding line (Example) - Please refer to the gas train documentation	24
4.14.2	Gas train	25
4.14.3	Gas train installation	25
4.14.4	Gas pressure.....	25

4.14.5	Pilot - gas train connection.....	26
4.14.6	Ignition pilot burner	26
4.15	Electrical wiring	27
4.15.1	Notes on terminals	27
4.15.2	Supply cables and external connections passage	28
4.15.3	Shielding the connections	29
4.16	Motor rotation.....	29
4.17	Calibration of the thermal relay	30
5	Start-up, calibration and operation of the burner	31
5.1	Notes on safety for the first start-up	31
5.2	Adjustments prior to ignition (light oil)	31
5.2.1	Nozzle	31
5.2.2	Combustion head.....	31
5.2.3	Pump pressure.....	31
5.3	Burner ignition (light oil)	31
5.4	Adjustments prior to ignition (gas)	32
5.5	Burner start-up (gas).....	32
5.6	Burner ignition	32
5.7	Change of fuel.....	32
5.8	Combustion air adjustment	33
5.8.1	Air / gas adjustment and output modulation.....	33
5.9	Pressure switch adjustment	34
5.9.1	Air pressure switch - check CO	34
5.9.2	Maximum gas pressure switch.....	34
5.9.3	Minimum gas pressure switch.....	34
5.9.4	PVP pressure switch kit	35
5.9.5	Oil pressure switch.....	35
5.10	Final checks (with burner operating).....	35
6	Maintenance	36
6.1	Notes on safety for the maintenance	36
6.2	Maintenance programme	36
6.2.1	Maintenance frequency.....	36
6.2.2	Safety test - with gas ball valve closed	36
6.2.3	Checking and cleaning.....	36
6.2.4	Safety components	37
6.2.5	Electrical panel.....	37
6.3	Checking the position of the rpm sensor	38
6.3.1	Pump unit.....	38
6.4	Opening the burner	40
6.5	Closing the burner.....	40
7	Faults - Probable causes - Solutions	41
A	Appendix - Accessories	42
B	Appendix - Electrical panel layout.....	44

1 Information and general warnings

1.1 Information about the instruction manual

1.1.1 Introduction

The instruction manual supplied with the burner:

- is an integral and essential part of the product and must not be separated from it; it must therefore be kept carefully for any necessary consultation and must accompany the burner even if it is transferred to another owner or user, or to another system. If the manual is lost or damaged, another copy must be requested from the Technical Assistance Centre of the area;
- is designed for use by qualified personnel;
- offers important indications and instructions relating to the installation safety, start-up, use and maintenance of the burner.

Symbols used in the manual

In some parts of the manual you will see triangular DANGER signs. Pay great attention to these, as they indicate a situation of potential danger.

1.1.2 General dangers

The **dangers** can be of **3 levels**, as indicated below.



Maximum danger level!
This symbol indicates operations which, if not carried out correctly, cause serious injury, death or long-term health risks.



This symbol indicates operations which, if not carried out correctly, may cause serious injury, death or long-term health risks.



This symbol indicates operations which, if not carried out correctly, may cause damage to the machine and/or injury to people.

1.1.3 Other symbols



DANGER: LIVE COMPONENTS
This symbol indicates operations which, if not carried out correctly, lead to electric shocks with lethal consequences.



DANGER: FLAMMABLE MATERIAL
This symbol indicates the presence of flammable materials.



DANGER: BURNING
This symbol indicates the risks of burns due to high temperatures.



DANGER: CRUSHING OF LIMBS
This symbol indicates the presence of moving parts: danger of crushing of limbs.



WARNING: MOVING PARTS
This symbol indicates that you must keep limbs away from moving mechanical parts; danger of crushing.



DANGER: EXPLOSION
This symbol signals places where an explosive atmosphere may be present. An explosive atmosphere is defined as a mixture - under atmospheric conditions - of air and flammable substances in the form of gases, vapours, mist or dust in which, after ignition has occurred, combustion spreads to the entire unburned mixture.



PERSONAL PROTECTION EQUIPMENT
These symbols indicate the equipment that must be worn and kept by the operator for protection against threats against safety and/or health while at work.



OBLIGATION TO ASSEMBLE THE COVER AND ALL THE SAFETY AND PROTECTION DEVICES
This symbol signals the obligation to reassemble the cover and all the safety and protection devices of the burner after any maintenance, cleaning or checking operations.



ENVIRONMENTAL PROTECTION
This symbol gives indications for the use of the machine with respect for the environment.



IMPORTANT INFORMATION
This symbol indicates important information that you must bear in mind.

- This symbol indicates a list.

Abbreviations used

Ch.	Chapter
Fig.	Figure
Page	Page
Sec.	Section
Tab.	Table

1.1.4 Delivery of the system and the instruction manual

When the system is delivered, it is important that:

- the instruction manual is delivered to the user by the system manufacturer, with the recommendation to keep it in the room where the heat generator is to be installed.
- The instruction manual shows:
 - the serial number of the burner;

.....

- the address and telephone number of the nearest Assistance Centre

.....

.....

.....

- The system supplier must carefully inform the user about:
 - the use of the system;
 - any further tests that may be required before activating the system;
 - maintenance, and the need to have the system checked at least once a year by a representative of the manufacturer or another specialised technician. To ensure a periodic check, the manufacturer recommends the drawing up of a Maintenance Contract.

1.2 Guarantee and responsibility

The manufacturer guarantees its new products from the date of installation, in accordance with the regulations in force and/or the sales contract. At the moment of the first start-up, check that the burner is integral and complete.



WARNING

Failure to observe the information given in this manual, operating negligence, incorrect installation and carrying out of non authorised modifications will result in the annulment by the manufacturer of the guarantee that it supplies with the burner.

In particular, the rights to the guarantee and the responsibility will no longer be valid, in the event of damage to things or injury to people, if such damage/injury was due to any of the following causes:

- incorrect installation, start-up, use and maintenance of the burner;
- improper, incorrect or unreasonable use of the burner;
- intervention of unqualified personnel;
- carrying out of unauthorised modifications on the equipment;
- use of the burner with safety devices that are faulty, incorrectly applied and/or not working;
- installation of untested supplementary components on the burner;
- powering of the burner with unsuitable fuels;
- faults in the fuel supply system;
- continuation of use of the burner when a fault has occurred;
- repairs and/or overhauls incorrectly carried out;
- modification of the combustion chamber with inserts that prevent the regular development of the structurally established flame;
- insufficient and inappropriate surveillance and care of those burner components most likely to be subject to wear and tear;
- use of non-original components, including spare parts, kits, accessories and optional;
- force majeure.

The manufacturer furthermore declines any and every responsibility for the failure to observe the contents of this manual.

2 Safety and prevention

2.1 Introduction

The burners have been designed and built in compliance with current regulations and directives, applying the known technical rules of safety and envisaging all the potential danger situations. It is necessary, however, to bear in mind that the imprudent and clumsy use of the equipment may lead to situations of death risk for the user or third parties, as well as the damaging of the burner or other items. Inattention, thoughtlessness and excessive confidence often cause accidents; the same applies to tiredness and sleepiness.

It is a good idea to remember the following:

- The burner must only be used as expressly described. Any other use should be considered improper and therefore dangerous.

In particular:

it can be applied to boilers operating with water, steam, diathermic oil, and to other uses expressly foreseen by the manufacturer;

the type and pressure of the fuel, the voltage and frequency of the electrical power supply, the minimum and maximum deliveries for which the burner has been regulated, the pressurisation of the combustion chamber, the dimensions of the combustion chamber and the ambient temperature must all be within the values indicated in the instruction manual.

- Modification of the burner to alter its performance and destinations is not allowed.
- The burner must be used in exemplary technical safety conditions. Any disturbances that could compromise safety must be quickly eliminated.
- Opening or tampering with the burner components is not allowed, apart from the parts requiring maintenance.
- Only those parts envisaged by the manufacturer can be replaced.



The manufacturer guarantees safety and proper functioning only if all burner components are intact and positioned correctly.

2.2 Personnel training

The user is the person, body or company that has acquired the machine and intends to use it for the specific purpose. He is responsible for the machine and for the training of the people working around it.

The user:

- undertakes to entrust the machine exclusively to suitably trained and qualified personnel;
- undertakes to inform his personnel in a suitable way about the application and observance of the safety instructions. With that aim, he undertakes to ensure that everyone knows the use and safety instructions for his own duties;
- Personnel must observe all the danger and caution indications shown on the machine.
- Personnel must not carry out, on their own initiative, operations or interventions that are not within their province.
- Personnel must inform their superiors of every problem or dangerous situation that may arise.
- The assembly of parts of other makes, or any modifications, can alter the characteristics of the machine and hence compromise operating safety. The manufacturer therefore declines any and every responsibility for any damage that may be caused by the use of non-original parts.

In addition:



- must take all the measures necessary to prevent unauthorised people gaining access to the machine;
- the user must inform the manufacturer if faults or malfunctioning of the accident prevention systems are noticed, along with any presumed danger situation;
- personnel must always use the personal protective equipment envisaged by legislation and follow the indications given in this manual.

3 Technical description of the burner

3.1 Burner designation

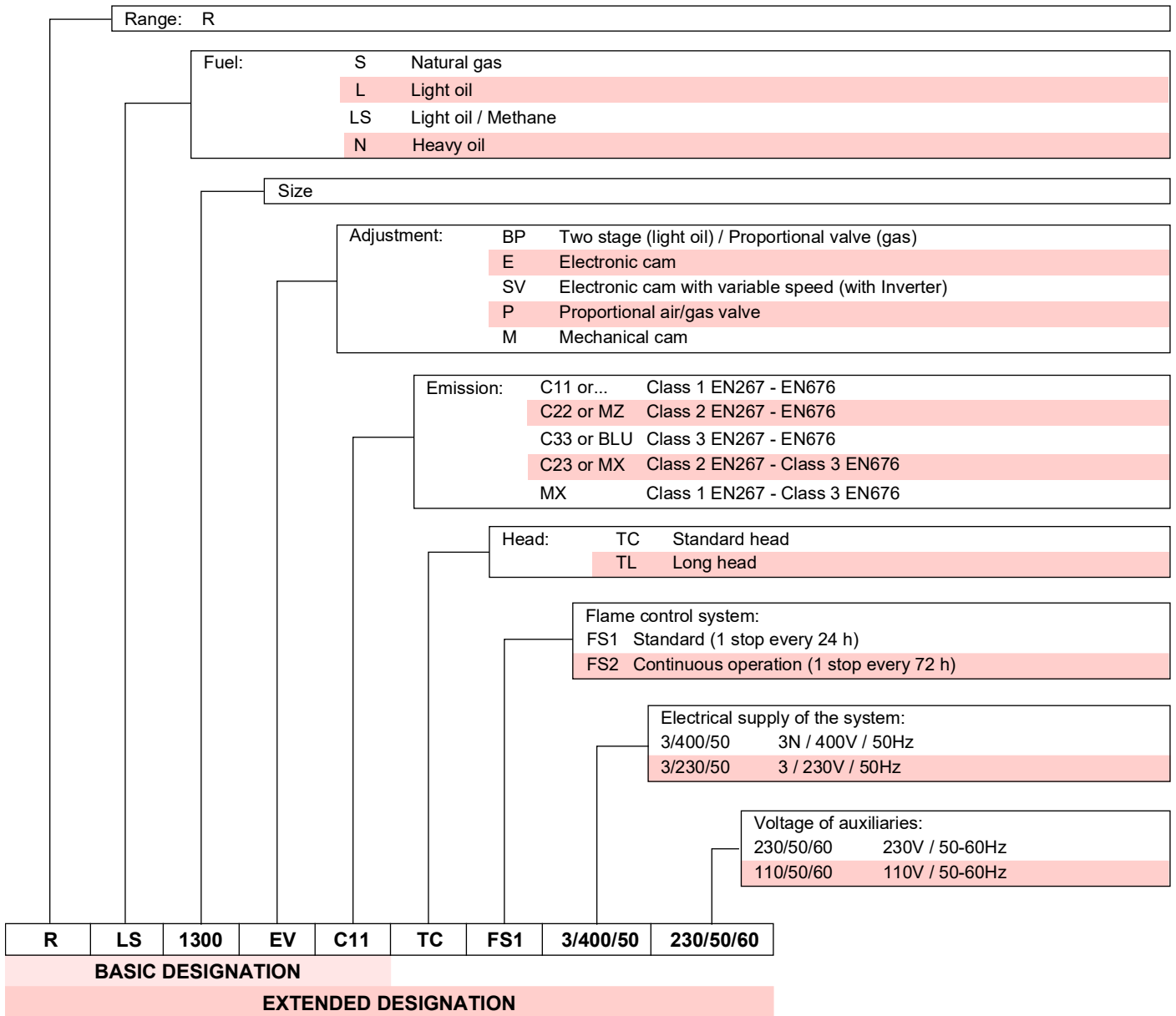

3.2 Models available

Designation	Voltage	Start-up	Code
RLS 1300/EV C11 TC	3/400/50	Direct/Inverter	20081187

3.3 Burner categories - Countries of destination

Country of destination	Gas category
AT - BG - CH - CZ - DK - EE - ES - FI - GB - GR - HU- IE - IS - IT - LT - LV - NO - PT - RO - SE - SI - SK - TR	I ₂ H
BE	I ₂ E(R)
DE	I ₂ ELL
LU - PL	I ₂ E
NL	I ₂ EK
FR	I ₂ Er

3.4 Technical data

Model			RLS 1300/EV C11
Type			LS001T2
Power ⁽¹⁾	min - max	kW	1100/7500 - 13000
Delivery ⁽¹⁾			kg/h
Fuels			– Light oil, max. viscosity at 20 °C: 6 mm ² /s (1.5°E - 6 cSt) – Natural gas: G20 (methane gas) - G25
Operation ⁽²⁾			– Intermittent/Continuous (1 stop every 24-72 hours) – Modulating
Nozzles		number	1
Standard applications			Boilers: water, steam, diathermic oil
Ambient temperature		°C	0 - 50
Combustion air temperature		°C max	60
Pump Output at 30 bar		l/h	3000
Pressure range		bar	15/40
Fuel temperature		°C max	150
Noise levels ⁽³⁾	Sound pressure	dB(A)	95
	Sound power		106
Weight		kg	1000
CE			CE-0476DQ3601

Tab. A

- (1) Reference conditions: Ambient temperature 20 °C - Gas temperature 15 °C - Barometric pressure 1,013 mbar - Altitude 0 m a.s.l.
 (2) The burners are factory set for FS1 operation (1 stop every 24 hours), but can be switched to the FS2 operation (continuous - 1 stop every 72 hours) by changing the parameters of the AZL display.
 (3) Sound pressure measured in manufacturer's combustion laboratory, with burner operating on test boiler and at maximum rated output. The sound power is measured with the "Free Field" method, as per EN 15036, and according to an accurate "Accuracy: Category 3" measurement, as described in EN ISO 3746.

3.5 Electrical data

Model			RLS 1300/EV C11
Electrical supply			3N ~ 400V 50 Hz
Maximum absorbed electric power	Light oil	kW max	39.2
	Gas		34.5
Protection level			IP 55

Tab. B

3.6 Maximum dimensions

The maximum dimensions of the burner are given in Fig. 1.
 Bear in mind that inspection of the combustion head requires the burner to be opened and the rear part turned on the hinge.

The maximum dimensions of the open burner are indicated by the L and R positions.

The I position is reference for the refractory thickness of the boiler door.

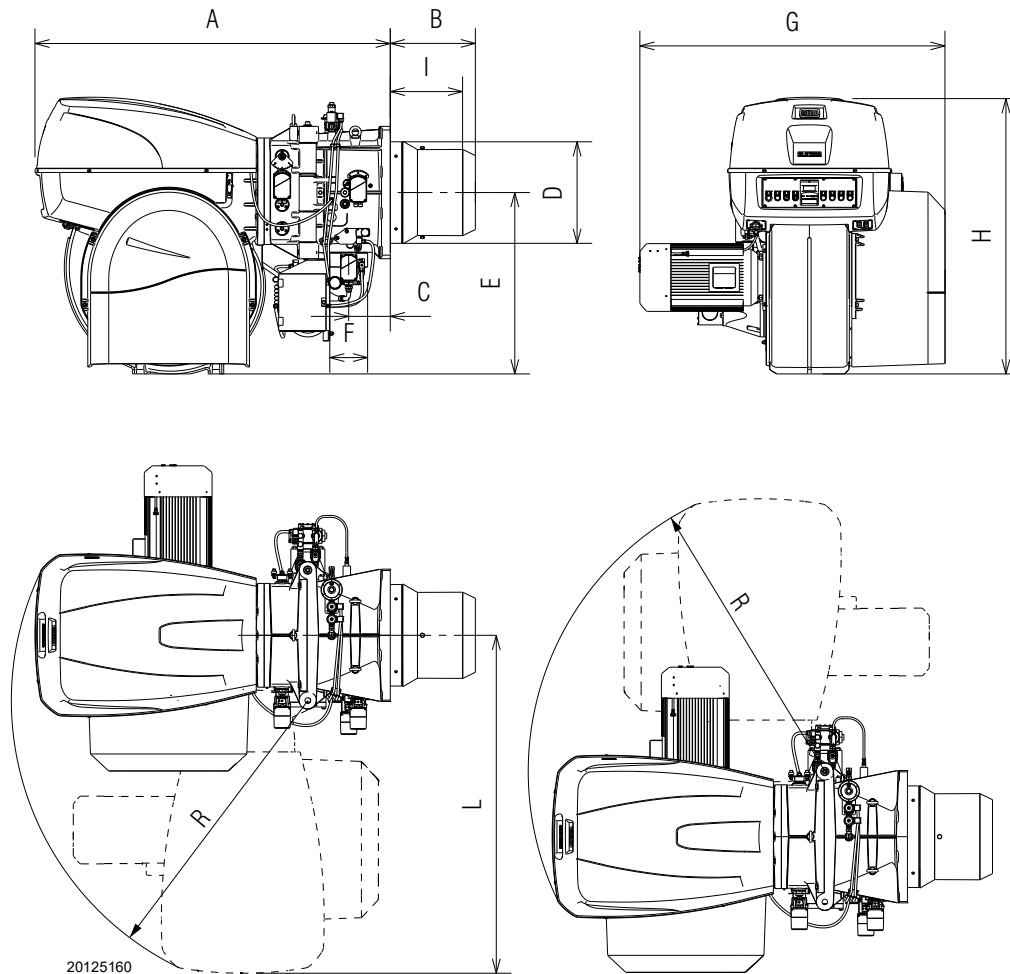

Fig. 1

mm	A	B	C	D	E	F	G	H	I	L	R
RLS 1300/EV C11	1880	450	220	544	459	DN80	1620	1463	380	1787	1564

Tab. C

3.7 Firing rates

The **MAXIMUM OUTPUT** is chosen from within the continuous diagram area (Fig. 2).

The **MINIMUM OUTPUT** must not be lower than the minimum limit of the diagram: **7500 kW**



The firing rate value (Fig. 2) has been obtained considering an ambient temperature of 20 °C, an atmospheric pressure of 1,013 mbar (approx. 0 m a.s.l.), and with the combustion head adjusted as shown on page 20.

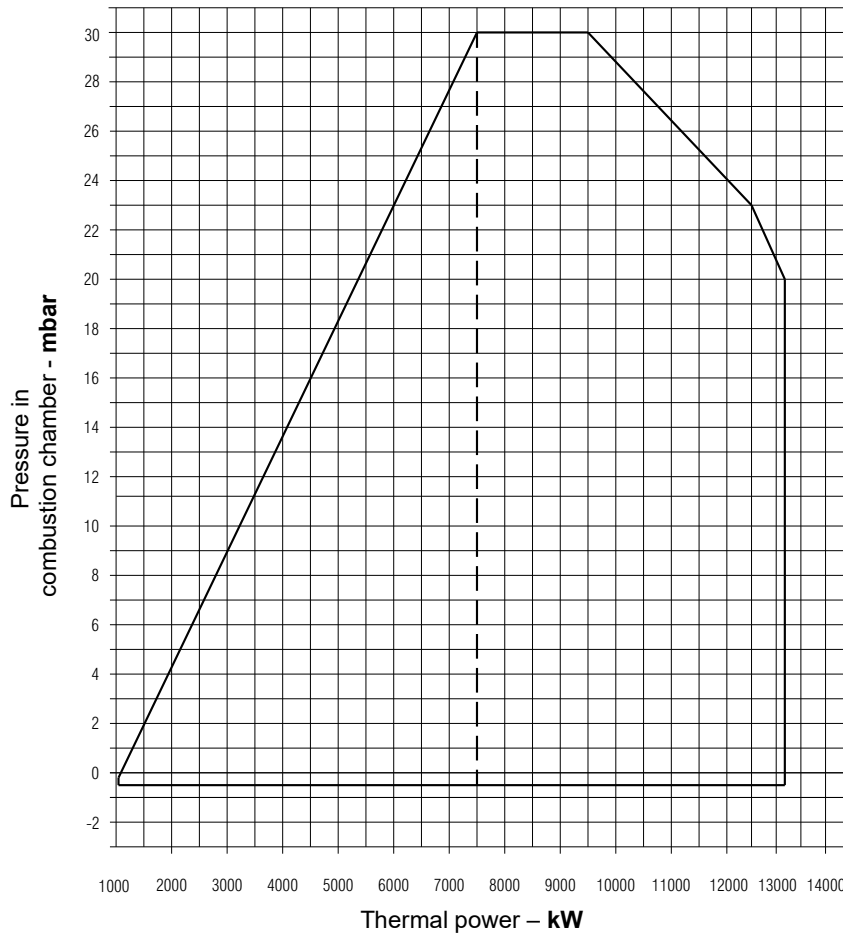

20125279

Fig. 2

3.8 Test boiler

The burner/boiler combination does not pose any problems if the boiler is EC approved and its combustion chamber dimensions are similar to those indicated in the diagram (Fig. 3).

If the burner must be combined with a boiler that has not been EC approved and/or its combustion chamber dimensions are clearly smaller than those indicated in the diagram, consult the manufacturer.

The firing rates were set in relation to special test boilers, according to EN 676 regulations.

In Fig. 3 you can see the diameter and length of the test combustion chamber.

Example:

Output 7000 kW - diameter 120 cm - length 6 m

MODULATING RATIO

The modulating ratio, obtained in test boilers, according to current standards (EN 676 for gas, EN 267 for light oil), is of 1:5 for gas and 1:4 for light oil.

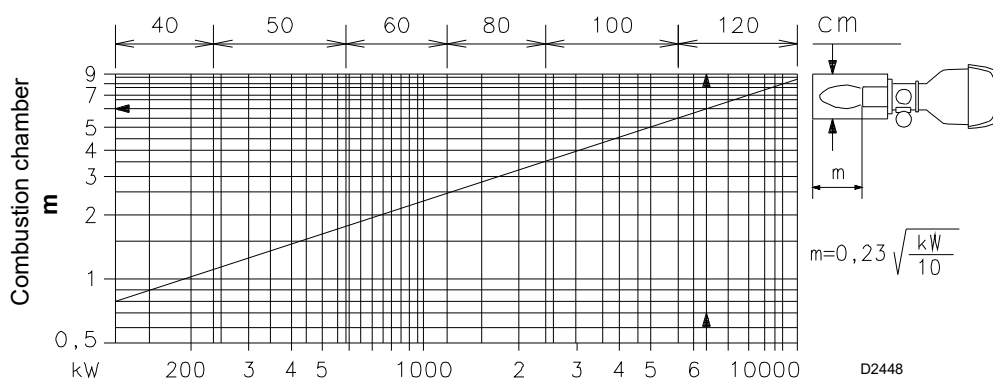

D2448

Fig. 3

3.9 Burner description

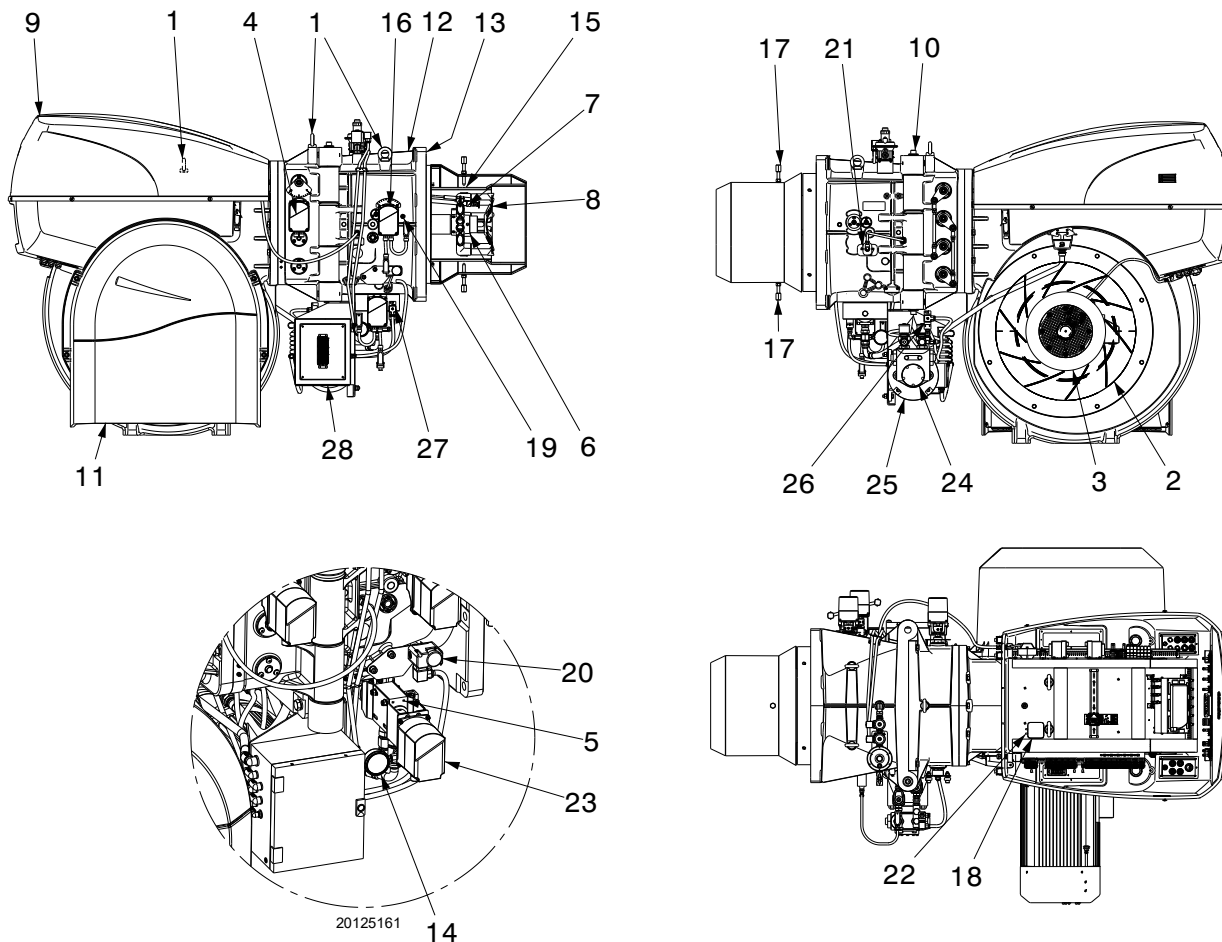

Fig. 4

- 1 Lifting rings
- 2 Impeller
- 3 Fan motor with rpm sensors
- 4 Air damper servomotor
- 5 Oil modulator
- 6 Combustion head
- 7 Ignition pilot burner
- 8 Flame stability disc
- 9 Electrical panel casing
- 10 Hinge pin for opening the burner
- 11 Fan air inlet
- 12 Pipe coupling
- 13 Gasket for boiler fixing
- 14 Nozzle return pressure gauge
- 15 Shutter
- 16 Combustion head servomotor movement
- 17 Screws to lock the shutter during transportation (replace them with the M12x25 screws supplied as standard)
- 18 Minimum air pressure switch (differential operating type)
- 19 Combustion head air pressure test point
- 20 Maximum gas pressure switch with pressure test point
- 21 QRI flame sensor
- 22 Pressure test point for air pressure switch "+"
- 23 Gas butterfly valve and oil modulator servomotor
- 24 Pump
- 25 Pump motor
- 26 Maximum oil pressure switch
- 27 Minimum oil pressure switch
- 28 Derivation unit terminal board box



CAUTION

The burner can be opened to the right or to the left without links to the fuel supply side.

When the burner is closed, the hinge pin can be refitted on the opposite side.

3.10 Electrical panel description

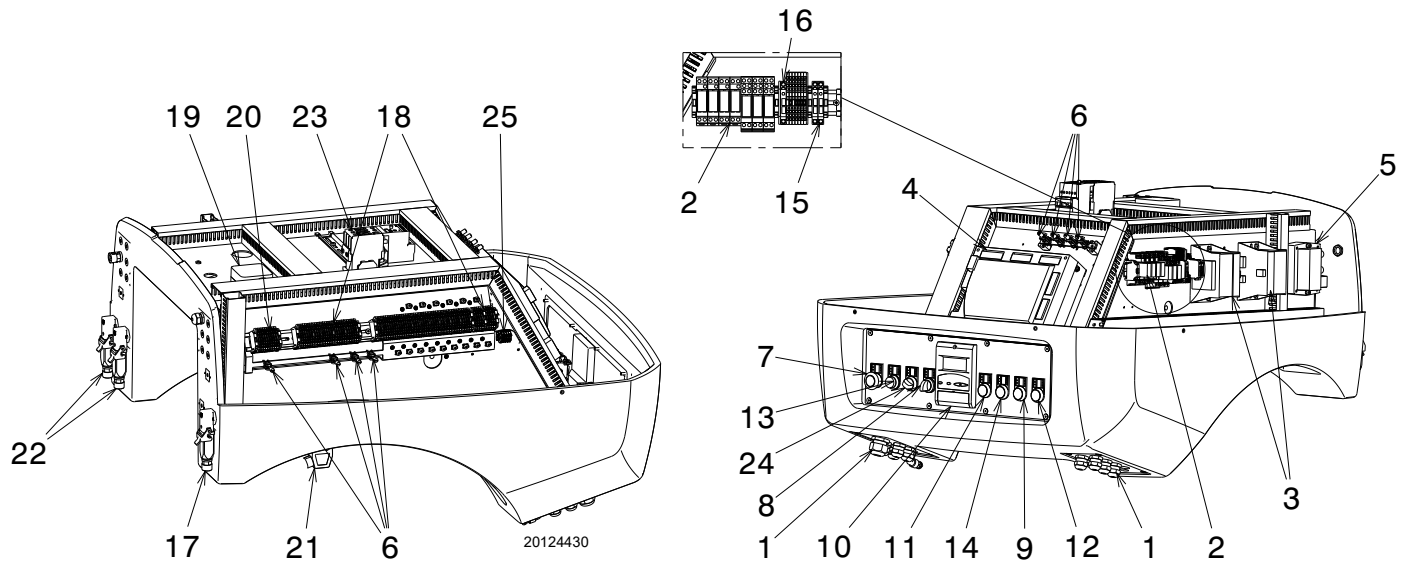

Fig. 5

- 1 Supply cables, external connections and kits
- 2 Volt-free contacts output relay
- 3 Electronic cam transformer
- 4 Flame control
- 5 Ignition transformer
- 6 Shielding terminals
- 7 Emergency button
- 8 Fuel selector and enable signal to remote fuel selector
- 9 Light signalling of main fuel valve open
- 10 AZL display
- 11 Voltage present warning lamp
- 12 Light signalling fan motor and pump motor lockout
- 13 Burner lockout warning lamp and reset switch
- 14 Heat request signal
- 15 Auxiliary transformer fuses
- 16 Auxiliary circuits fuse
- 17 Flame sensor plug/sensor socket
- 18 Main terminal supply board

- 19 Air pressure switch
- 20 Terminal board for O₂ kit
- 21 Plug/Oil valve socket/pump motor (derivation unit)
- 22 Plug/socket servomotor
- 23 Pump motor contactor and thermal relay
- 24 Off-automatic selector
- 25 Rpm sensor terminal board

NOTE

Two types of burner failure may occur:

- **flame control lockout:** the switching on of the button (**red led**) 13)(Fig. 5) signals that the burner is in lockout. Release by pressing button 13)(Fig. 5) or use the display.
- **Motor lockout:** release the pump motor by pressing the button on the relevant thermal relay. See the inverter manual for the release of the fan motor.

3.11 Burner equipment

Gasket for gas train flange DN80	No. 1
M 16 x 50 gas flange fastener screws	No. 8
Thermal insulation screen	No. 1
Bolts M 20 x 70 for fixing the burner flange to the boiler.	No. 12
M20 Nut	No. 12
Pressure switch (for leak detection control)	No. 1
Light oil flexible hoses	No. 2
Fitting 1" 1/2 - 3/4"	No. 1
Fitting 3/4" - 1/2"	No. 1
Rotating elbow 1/2"	No. 1
Instructions	No. 1
Spare parts list	No. 1



It is recommended to tighten the screws of the gas flange with a tightening torque of

- DN80: **40 Nm ±10%**
- DN100: **50 Nm ±10%**
- DN125: **60 Nm ±10%**

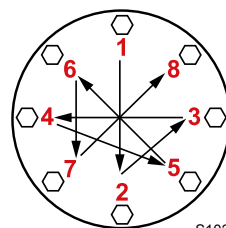

Tighten the nuts gradually (first to 30%, then to 60% up to 100%) according to the cross pattern shown in the figure.

S10230

3.12 AZL Display...

Important notes



WARNING

To avoid accidents, material or environmental damage, observe the following instructions!

The AZL... display is a safety device! Avoid opening or modifying it, or forcing its operation. Riello S.p.A. cannot assume any responsibility for damage resulting from unauthorised interventions!

The electronic cam is operated and programmed through the AZL5 interface... or with the aid of a PC.

The AZL5 has a backlit LCD display with clear reading of the menu text and diagnostics.

The Modbus function of the AZL display integrates the electronic cam LMV5 and through data management allows the diagnostic of the burner.

The display shows the operating status, the types of errors and lockouts. Used to parameterize and monitor data.



Fig. 6

Technical data

Operating voltage	AC 24 V - 15% / +10%
Power consumption	< 5W (typical)
Protection level of the container	
– Rear	IP00 according to IEC 529
– Front	IP54 according to IEC 529 (if installed)
Safety class	I with parts II and III according to DIN EN 60730-1
Battery - Manufacturer:	Type reference:
VARTA	CR 2430 (LF-1/2 W)
DURACELL	DL 2430
SANYO ELECTRIC, Osaka/ Japan	CR 2430 (LF-1/2 W)
RENATA AG, Itingen/CH	CR 2430

Tab. D

3.13 Flame control (LMV52...)

Important notes



To avoid accidents, material or environmental damage, observe the following instructions!

The LMV52 flame control... is a safety device! Avoid opening or modifying it, or forcing its operation. Riello S.p.A. cannot assume any responsibility for damage resulting from unauthorised interventions!

Risk of explosion!

An incorrect configuration can provoke fuel overcharging, with the consequential risk of explosion! Operators must be aware that incorrect settings made on the AZL5... display and operating unit and incorrect settings of the fuel and / or air actuator positions can lead to dangerous burner operating conditions.

- All interventions (assembly and installation operations, assistance, etc.) must be carried out by qualified personnel.
- Before modifying the wiring in the LMV52 flame control connection area, fully disconnect the system from the power supply (omnipolar separation). Check the system is not powered and cannot be accidentally reconnected. Failure to do this will lead to the risk of electrocution.
- Protection against electrocution from the LMV5... flame control and all connected electric components is obtained with correct assembly.
- Before any intervention (assembly and installation operations, assistance, etc.), ensure the wiring is in order and that the parameters are correctly set, then make the safety checks.
- Falls and collisions can negatively affect the safety functions.
In this case, the flame control must not be operated, even if it displays no evident damage.
- In programming mode, the position check of actuators and VSD (checking electronic fuel / air ratio control) is different from the check during automatic operation. As for automatic operation, the actuators are guided together to the positions requested and, if an actuator does not reach the position requested, adjustments are made until the position is actually reached. However, in contrast to automatic operation, there are no time limits to these corrective actions. The other actuators maintain their positions until all actuators have reached the positions currently required.
This is absolutely important to set the fuel / air ratio control system.
During the time the fuel / air ratio curves are being programmed, the person making the plant settings must continuously monitor the quality of the combustion process (e.g. by means of a flue gas analyser). Also, if combustion levels are poor, or in the event of dangerous situations, the commissioning engineer must take appropriate action (e.g. switching off manually).

To ensure the safety and reliability of the LMV5... system, the following instructions must also be followed:

- avoid conditions that can favour the development of condensate and humidity. Otherwise, before switching on again, make sure that the entire flame control is perfectly dry!
- Static charges must be avoided since they can damage the flame control's electronic components when touched.



D9301

Fig. 7

Mechanical structure

The LMV5... flame control is a system to check the burners, based on a microprocessor and equipped with components to adjust and monitor medium and large capacity forced draught burners.

The base flame control of the LMV5... system incorporates the following components:

- Burner control with gas valve proving system
- Electronic fuel / air ratio control with a maximum of 4 (LMV51...) or 6 (LMV52...) actuators
- Optional PID temperature / pressure controller (load controller)
- Optional VSD module Mechanical design

Installation notes

- Check the electric wiring inside the boiler complies with the national and local safety regulations.
- Do not confuse the powered conductors with the neutral ones.
- Make sure the cable grommets of the connected cables comply with the relevant standards (e.g. DIN EN 60730 and DIN EN 60335).
- Ensure that spliced wires cannot get into contact with neighbouring terminals. Use adequate ferrules.
- Arrange the HV ignition cables separately, as far as possible from the flame control and the other cables
- The burner manufacturer must protect unused AC 230V terminals with dummy plugs (refer to sections Suppliers of other accessory items).
- When wiring the unit, make sure that AC 230V mains voltage cables are run strictly separate from extra low-voltage cables to avoid risks of electrical shock hazard.

Electrical connection of flame detector

It is important for signal transmission to be almost totally free of any disturbances or loss:

- always separate the detector cables from the other cables:

- Line capacitance reduces the magnitude of the flame signal.
- Use a separate cable.
- Respect the allowed cable lengths.

Technical data

LMV52... base flame control	Mains voltage	AC 230V -15% / +10%
	Mains frequency	50 / 60 Hz ±6%
	Power absorption	< 30W (normal)
	Safety class	I, with components in compliance with II and III, according to DIN EN 60730-1
Load on 'input' terminals	F1 unit fuse (internal)	6.3 AT
	Primary perm. mains fuse (external)	Max. 16 AT
	Undervoltage	
	• Safety switch-off from operating position to mains voltage	< AC 186V
	• Restart when mains voltage picks up	> AC 188V
	Oil pump / magnetic clutch (nominal voltage)	
	• Nominal current	2A
• Power factor	cosφ > 0.4	
Load on 'output' terminals	Air pressure switch test valve (nominal voltage)	
	• Nominal current	0.5A
	• Power factor	cosφ > 0.4
	Total load on the contacts:	
• Mains voltage	AC 230V -15% / +10%	
• Total unit input current (safety circuit)	Max. 5 A	
	load on contacts due to:	
	- Fan motor contactor	
	- Ignition transformer	
	- Valve	
	- Oil pump / magnetic clutch	
	Single contact loading:	
	Fan motor contactor (nominal voltage)	
	• Nominal current	1A
	• Power factor	cosφ > 0.4
	Alarm output (nominal voltage)	
	• Nominal current	1A
	• Power factor	cosφ > 0.4
	Ignition transformer (nominal voltage)	
	• Nominal current	2A
	• Power factor	cosφ > 0.2
	Fuel gas valve (nominal voltage)	
	• Nominal current	2A
	• Power factor	cosφ > 0.4
	Fuel oil valve (nominal voltage)	
	• Nominal current	1A
	• Power factor	cosφ > 0.4
Cable length	Main line	Max. 100 m (100 pF / m)
Environmental conditions	Operation	DIN EN 60721-3-3
	Climatic conditions	Class 3K3
	Mechanical conditions	Class 3M3
	Temperature range	-20...+60 °C
	Humidity	< 95% RH

3.14 Servomotor (SQM48.4....)

Important notes



WARNING

To avoid accidents, material or environmental damage, observe the following instructions!

Avoid opening, modifying or forcing the actuators.

- All interventions (assembly and installation operations, assistance, etc.) must be carried out by qualified personnel.
- Before modifying the wiring in the SQM4... system connection area, fully disconnect the burner control device from the power supply (omnipolar separation).
- To avoid the risk of electrocution, protect the connection terminals in a suitable manner and correctly fix the cover.
- Check the wiring is in order.
- Falls and collisions can negatively affect the safety functions. In this case, the unit must not be operated, even if it displays no evident damage.

Assembly notes

- Check the relevant national safety standards are respected.
- The connection between the actuator command shaft and the control element must be rigid, without any mechanical play.
- To avoid an excessive load on the bearings due to rigid hubs, the use of compensation clutches without any mechanical play is recommended (e.g. metal bellows-type clutches).

Installation notes

- Arrange the HV ignition cables separately, as far as possible from the flame control and the other cables.
- To avoid the risk of electrocution, make sure that the 230V AC section of the SQM4... unit is fully separated from the functional low-voltage section.
- The static torque is reduced when the electrical supply of the actuator is switched off.
- The housing cover may only be removed for short periods of time for wiring or when making the addressing. In similar cases, make sure that dust or dirt does not penetrate inside the actuator.
- The actuator comprises a PCB with ESD-sensitive components.
- The top side of the board carries a cover which affords protection against direct contact. This protective cover must not be removed! The underside side of the board must not be touched.



WARNING

During the maintenance or replacement of the actuators, be careful not to invert the connectors.

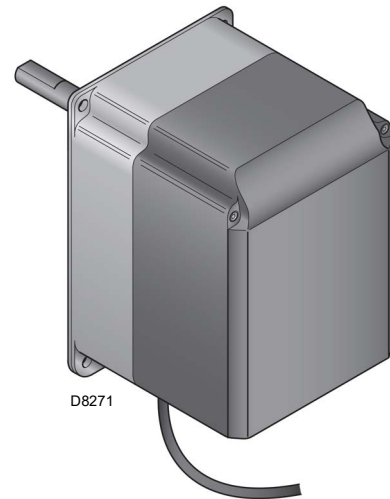

Fig. 8

Technical data

Operating voltage	AC 2 x 12V via bus cable from the base unit or via a separate transformer
Safety class	extra low-voltage with safe isolation from mains voltage
Power absorption	26...34 VA
Protection level	to EN 60 529, IP 54, provided adequate cable entries are used
Cable connection	RAST3,5 connectors
Rotation direction	- Anticlockwise (standard) - Clockwise (inverted rotation)
Rated torque (max.)	20 Nm
Static torque (max.)	20 Nm
Operation time (min.) for 90°	30 s.
Weight	approx. 1.6 kg
Environmental conditions:	
Operation	DIN EN 60 721-3-3
Climatic conditions	Class 3K3
Mechanical conditions	Class 3M3
Temperature range	-20...+60 °C
Humidity	< 95% RH

Tab. E

4 Installation

4.1 Notes on safety for the installation

After carefully cleaning all around the area where the burner is to be installed, and arranging for the environment to be illuminated correctly, proceed with the installation operations.



All the installation, maintenance and disassembly operations must be carried out with the electricity supply disconnected.



The installation of the burner must be carried out by qualified personnel, as indicated in this manual and in compliance with the standards and regulations of the laws in force.



Combustion air inside the boiler must be free from hazardous mixes (e.g.: chloride, fluoride, halogen); if present, it is highly recommended to carry out cleaning and maintenance more frequently.

4.2 Handling

The burner packaging includes a wooden platform, it is therefore possible to move the burner (still packaged) with a transpallet truck or fork lift truck.



The handling operations for the burner can be highly dangerous if not carried out with the greatest attention: keep any unauthorised people at a distance; check the integrity and suitability of the available means of handling. Check also that the area in which you are working is empty and that there is an adequate escape area (i.e. a free, safe area to which you can quickly move if the burner should fall). When handling, keep the load at not more than 20-25 cm from the ground.

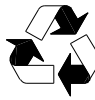

After positioning the burner near the installation point, correctly dispose of all residual packaging, separating the various types of material.



Before proceeding with the installation operations, carefully clean all around the area where the burner will be installed.

4.3 Preliminary checks

Checking the consignment



After removing all the packaging, check the integrity of the contents. In the event of doubt, do not use the burner; contact the supplier.



The packaging elements (wooden cage or cardboard box, nails, clips, plastic bags, etc.) must not be abandoned as they are potential sources of danger and pollution; they should be collected and disposed of in the appropriate places.

		A		B	
		D		C	
		E		F	
GAS-KAASU	<input type="checkbox"/> FAM.2	G		H	
GAZ-AEPIO	<input type="checkbox"/> FAM.3	G		H	
		I			
		L			
				CE	
		[Barcode]			

20206732

Checking the characteristics of the burner

- Check the identification label of the burner, showing:
- the model (A)(Fig. 9) and type of burner (B);
 - the year of manufacture, in cryptographic form (C);
 - the serial number (D);
 - the data for electrical supply and the protection level (E);
 - maximum electric power consumption (F);
 - the types of gas used and the relative supply pressures (G);
 - the data of the burner's minimum and maximum output possibilities (H)(see Firing rate).
- Warning.** The burner output must be within the boiler's firing rate;
- the category of the appliance/countries of destination (I).
 - light oil maximum viscosity (L).



A burner label that has been tampered with, removed or is missing, along with anything else that prevents the definite identification of the burner makes any installation or maintenance work difficult.

Fig. 9

4.4 Operating position



- The burner is designed to work only in positions **1** and **4** (Fig. 10).
- Installation **1** is preferable, as it is the only one that allows the maintenance operations as described in this manual.
- The installation **4** permits the operation, but makes the maintenance and inspection operations of the combustion head more difficult.



- Any other position could compromise the correct operation of the appliance.
- Installation **5** is prohibited for safety reasons.

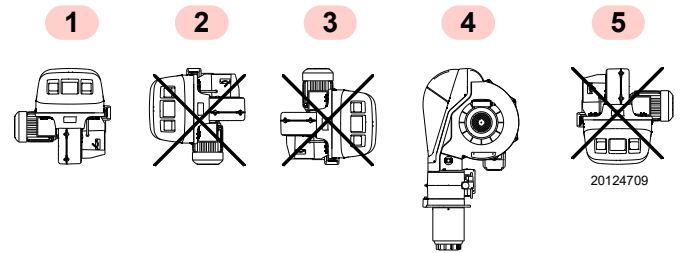

Fig. 10

4.5 Removing the shutter lockout screws

Remove the screws 1)-2) and nuts before fitting the burner onto the boiler (Fig. 11). Replace them with the screws 3) M12x16 supplied as standard.

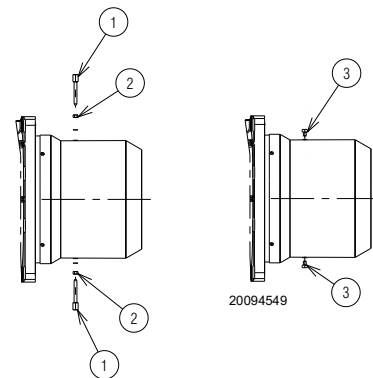

Fig. 11

4.6 Preparing the boiler

4.6.1 Boring the boiler plate

Pierce the closing plate of the combustion chamber, as in Fig. 12. The position of the threaded holes can be marked using the thermal insulation screen supplied with the burner.

4.6.2 Blast tube length

The length of the blast tube must be selected according to the indications provided by the manufacturer of the boiler, and in any case it must be greater than the thickness of the boiler door complete with its fettling.

For boilers with a front flue gas passes 1)(Fig. 13) or flame inversion chamber, a protection device in refractory material 5) must be inserted between the boiler fettling 2) and the blast tube 4).

This protective fettling must not compromise the extraction of the blast tube.

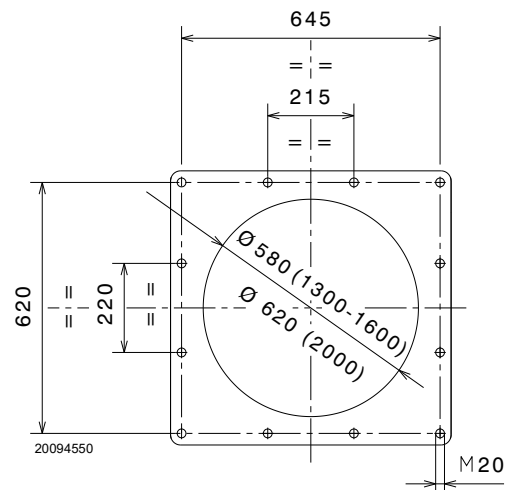

Fig. 12

4.7 Securing the burner to the boiler



Prepare a suitable lifting system using rings 3)(Fig. 13).

- Insert the thermal protection supplied with the blast tube 4).
- Insert the entire burner on the boiler hole, previously fitted, as in Fig. 12, and fix it with the screws supplied.



WARNING

The seal between burner and boiler must be airtight.

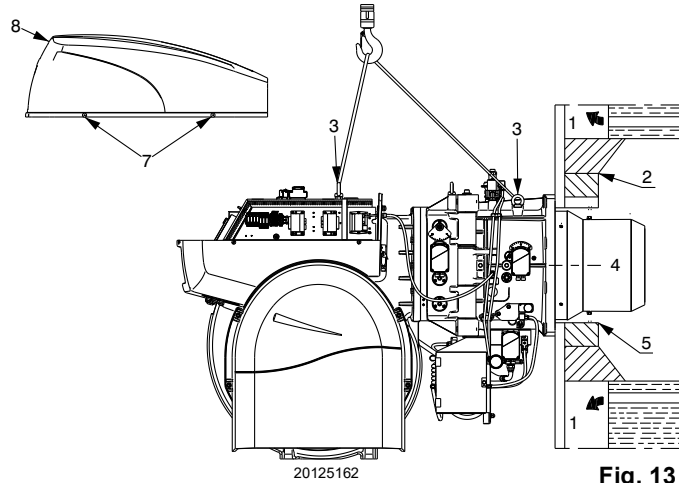

Fig. 13

4.8 Access to head internal part

In order to reach inside the combustion head (Fig. 14) proceed as follows:

- disconnect the derivation unit socket 1) and the QRI photo-cell 2);
- disconnect the servomotor sockets;
- remove the cover;
- disconnect the cable of the electrode 12) from the transformer 13) and remove it by unscrewing the fitting 14);
- unscrew the 4 fixing screws of the pipe coupling 4);
- open the burner on the hinge
- disconnect the cable of the pilot electrode 5);
- release the ignition pilot fitting 6);
- disconnect the light oil pipes 7);
- unscrew the lockout screw 9) of the oil lance 10);
- extract the oil lance 10) from the combustion head 11);
- remove the combustion head 11) from the pipe coupling.



Be careful as fuel may leak during this phase.

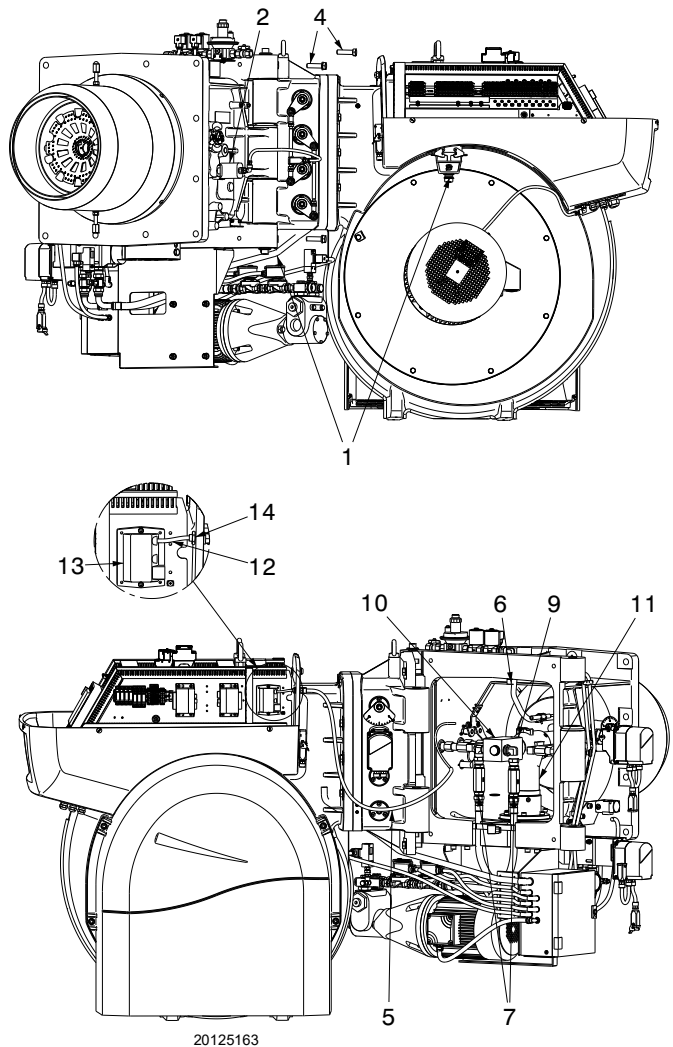

Fig. 14

4.9 Nozzle installation

The burner complies with the emission requirements of the EN 267 standard. In order to guarantee that emissions do not vary, recommended and/or alternative nozzles specified by Riello in the Instruction and warning booklet should be used.



WARNING

It is advisable to replace the nozzle once a year during periodical maintenance.



CAUTION

The use of nozzles other than those specified by Riello S.p.A. and inadequate regular maintenance may result into emission limits non-conforming to the values set forth by the regulations in force, and in extremely serious cases, into potential hazards to people and objects.

The manufacturing company shall not be liable for any such damage arising from non-observance of the requirements contained in this manual.

Fit the nozzle with the 24-mm pipe wrench, passing through the central opening of the flame balance disc (Fig. 15) or remove the lance.



WARNING

- Do not use any sealing products such as gaskets, sealing compound, or tape.
- Be careful to avoid damaging the nozzle sealing seat.
- The nozzle must be screwed into place tightly but not to the maximum torque value provided by the wrench.

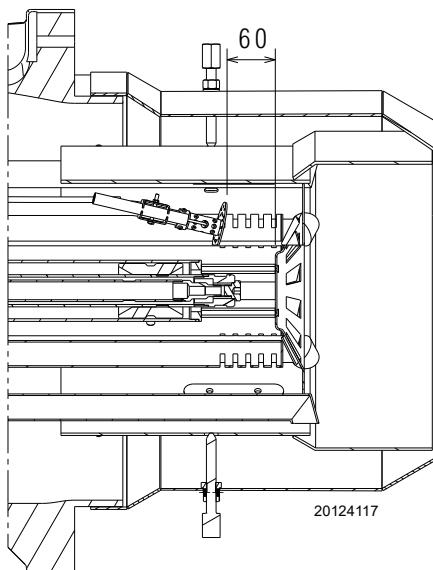

Fig. 15

4.9.1 Recommended nozzle

Model	Nozzle
RLS 1300/EV C11	– Fluidics 22N1

Complete range of nozzles:

- Fluidics type 22N1:
400 - 450 - 500 - 550 - 600 - 650 - 700 - 750 - 800 - 850 - 900 - 950 - 1000 - 1100.

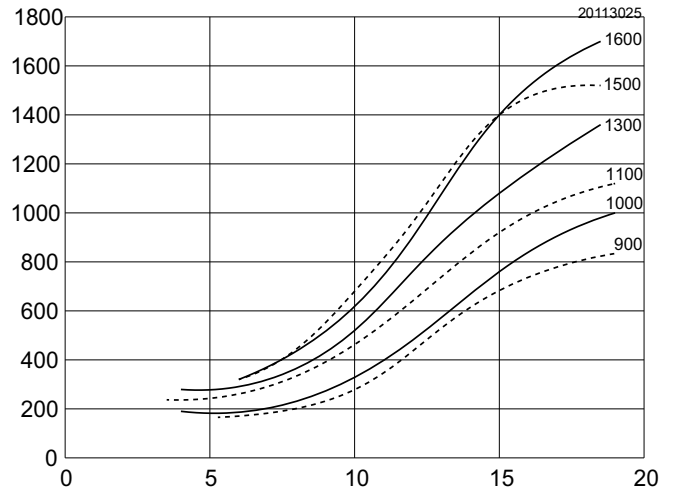

Fig. 16

4.10 Electrode position



Place the electrode on the ignition pilot observing the dimensions specified in Fig. 17.

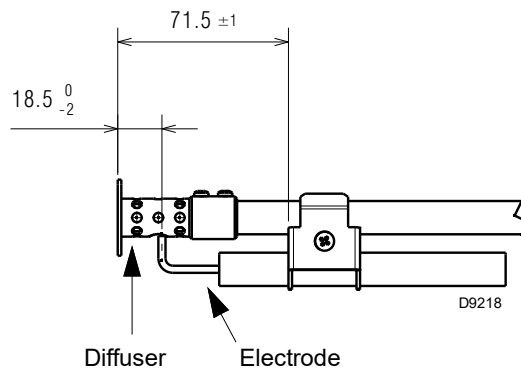

Fig. 17

4.11 Combustion head adjustment

The air damper servomotor 4 (Fig. 18), varies the air output according to the output demand, while another servomotor varies the combustion head adjustment.

This system allows an optimum adjustment also at the minimum firing rate.



The gas pipes leave the factory calibrated at notch 1. The adjustment shown in Fig. 19 allows the gas pipes to be positioned in the best way for the application on which the burner is installed (e.g. boilers with flame inversion chamber).

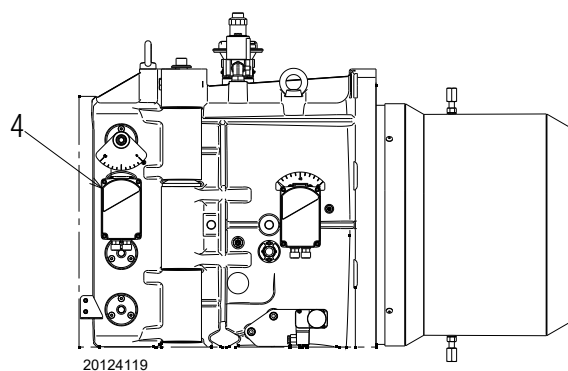

Fig. 18

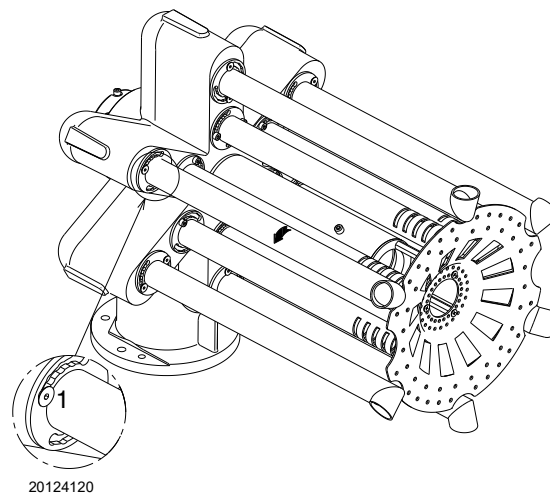

Fig. 19

4.12 Light oil supply



Explosion danger due to fuel leaks in the presence of a flammable source.

Precautions: avoid knocking, attrition, sparks and heat.

Make sure the fuel interception tap is closed before performing any operation on the burner.



WARNING

The fuel supply line must be installed by qualified personnel, in compliance with current standards and laws.

4.12.1 Double-pipe circuit

The burner is equipped with a self-priming pump which is capable of feeding itself within the limits listed in Tab. F.

Tank higher than burner A (Fig. 20)

Distance "P" must not exceed 10 meters in order to avoid straining the pump's seal; distance "V" must not exceed 4 meters in order to allow pump self-priming even when the tank is almost empty.

Tank lower than burner B (Fig. 20)

Pump depression values higher than 0.45 bar (35 cm Hg) must not be exceeded. because at higher levels gas is released from the fuel, the pump starts making noise and its working life-span decreases.

It is good practice to ensure that the return and suction lines enter the burner from the same height; in this way it will be less probable that the suction line fails to prime or stops priming.

4.12.2 The loop circuit

A loop circuit consists of a loop of piping departing from and returning to the tank with an auxiliary pump that circulates the fuel under pressure. A branch connection from the loop feeds the burner.

This circuit is extremely useful whenever the burner pump does not succeed in self-priming because the tank distance and/or height difference are higher than the values listed in Tab. F.

+/- H [m]	RLS 1300/EV C11			
	Ø [mm]			
	22	24	27	36
4.0	19	33	65	300
3.0	16	28	55	260
2.0	13	23	45	220
1.0	10	18	38	185
0.5	9	16	33	165
0	7	13	30	145
-4.0	-	-	-	-
-3.0	-	-	-	30
-2.0	-	-	11	70
-1.0	-	9	20	108
-0.5	5	11	25	125
0	7	13	29	145

Tab. F

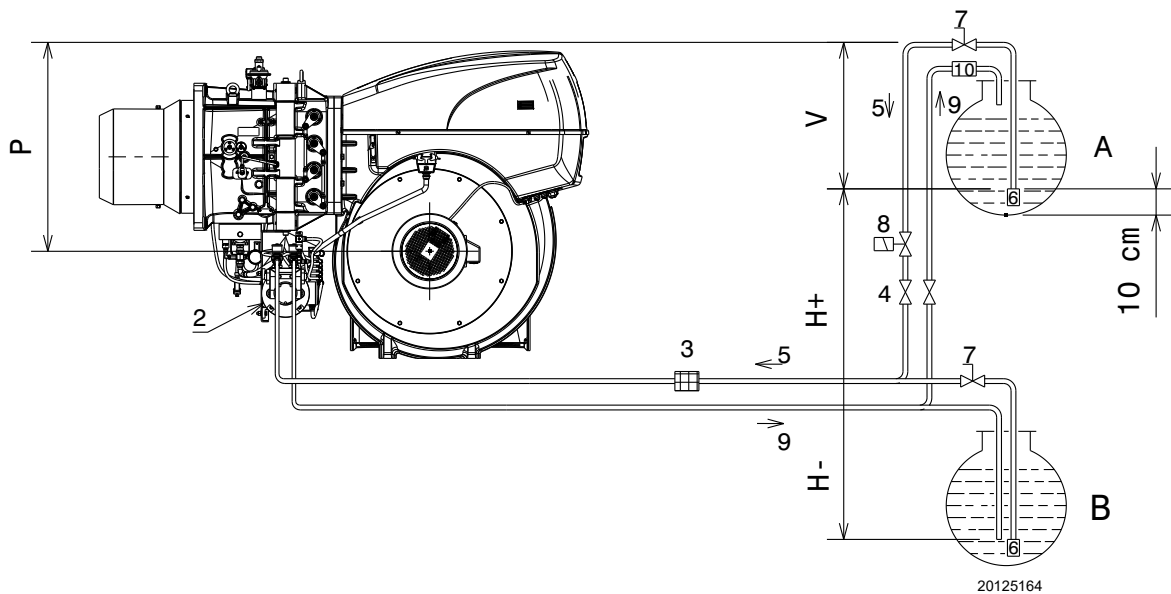

Fig. 20

Key (Fig. 20)

- H = Pump/Foot valve height difference
- L = Piping length
- Ø = Inside pipe diameter
- 1 = Burner
- 2 = Pump
- 3 = Filter
- 4 = Manual on/off valve

- 5 = Suction line
- 6 = Foot valve
- 7 = Quick closing manual valve with remote control (Italy only)
- 8 = On/off solenoid valve (Italy only). See electrical layout. Connections to be carried out by the installer (SV).
- 9 = Return line
- 10 = Check valve (only Italy)

4.12.3 Hydraulic connections



- Make sure that the flexible hoses to the pump supply and return line are installed correctly.



- Follow the instructions below:
- Tighten the flexible hoses with the supplied gaskets.
 - Take care that the hoses are not stretched or twisted during installation.
 - Place the pipes so that they are not crushed or are in contact with hot parts of the boiler and so it is possible to open the burner.
 - Finally, connect the other end of the flexible hoses to the suction and return pipes.

4.12.4 Hydraulic circuit diagram

Key (Fig. 21)

- 1 Pump suction
- 2 Pump return line and nozzle return line
- 3 Pump pressure regulator
- 4 Delivery safety valve
- 5 Delivery safety valve
- 6 Nozzle delivery line
- 7 Nozzle without interception rod
- 8 Nozzle return line
- 9 Pressure variator on nozzle return line
- 10 Pressure variator servomotor
- 11 Pressure switch on nozzle return line
- 12 Safety valve on nozzle return line
- 13 Safety valve on nozzle return line
- 14 Pressure switch on pump delivery line
- M Pressure gauges
- V Vacuumeter connection

TEST

Pre-purging phase:

valves 4), 5), 12) and 13) closed.

Ignition and operation phase:

valves 4), 4), 12) and 13) open.

Stop: All valves closed.

4.12.5 Pressure variator

The pressure variator (Fig. 22), allows the pressure on the return line of the nozzle to be varied according to the required output.

The pressure on the return line is adjusted by varying a section by means of the rotation of the servomotor 23)(Fig. 4), which also controls the gas butterfly valve at the same time.

- Regulator at 0° (maximum opening) = minimum pressure on the nozzle return line.
- Regulator at 90° (minimum opening) = maximum pressure on the nozzle return line.

The servomotor is controlled by the electronic cam 3)(Fig. 5); thanks to this device, it is possible to set different curves for oil and gas on the same servomotor (also for the air damper servomotor 4)(Fig. 4).

- When **adjusting the gas**, it is recommended the servomotor be adjusted to about 90° to reduce leaks from the gas butterfly valve.
- When **adjusting the oil**, the adjustment is done based on the nozzle fitted and on the required degree of modulation; in a situation of minimum firing rate, a rotation of 20° can be enough.

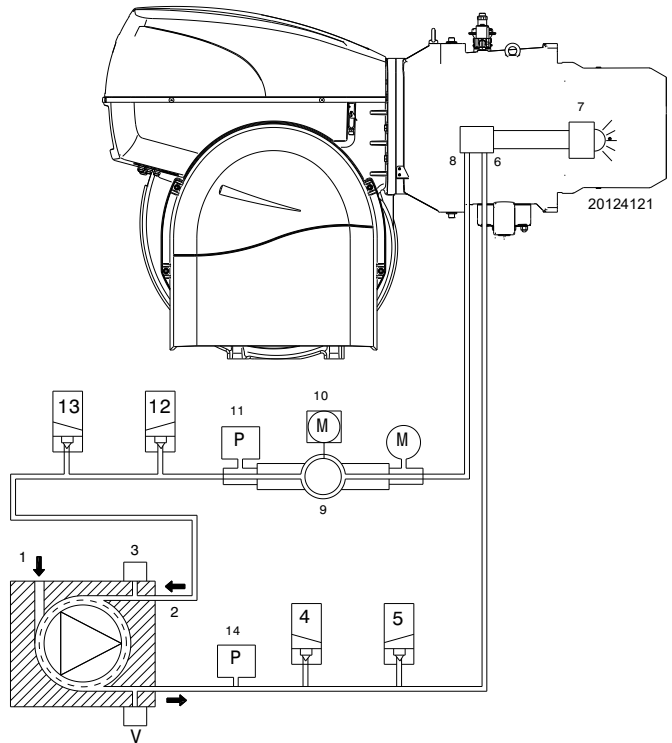

Fig. 21

Key (Fig. 22)

- 1 Nozzle return pressure gauge
- 2 Position indicator (0 ÷ 90) of the pressure variator
- 3 Maximum oil pressure switch on return circuit

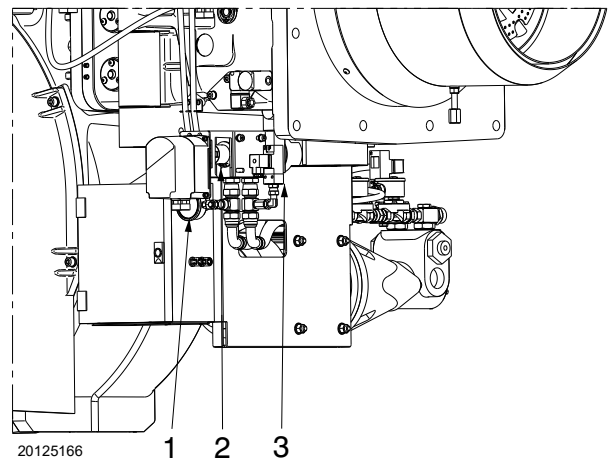

Fig. 22

4.13 Pump

4.13.1 Technical data

Pump

**RLS 1300/EV C11
VBHGRPZ**

Min. delivery rate at 30 bar pressure	3000 l/h
Delivery pressure range	9 - 40 bar
Max. suction depression	0.6 bar
Viscosity range	6 - 800 cSt
Max. light oil temperature	150 °C
Max. suction and return pressure	5 bar
Pressure calibration in the factory	25 bar

Tab. G

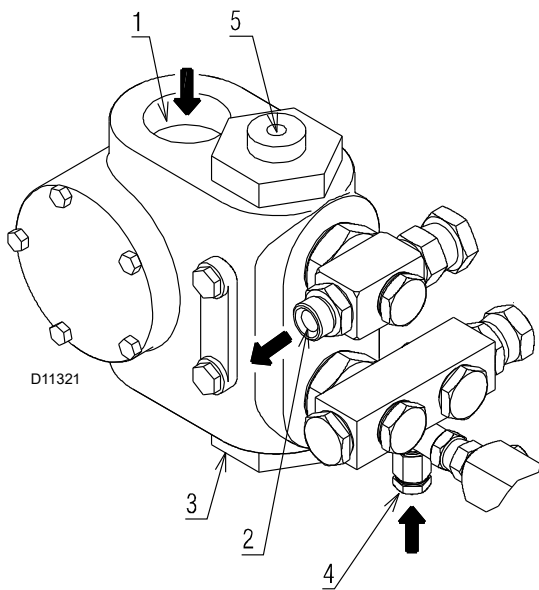

Fig. 23

Key (Fig. 23)

- | | |
|---------------------|----------|
| 1 Suction line | G 1" 1/2 |
| 2 Return line | G 1" |
| 3 Vacuum connection | G 1/4" |
| 4 Gauge connection | G 1/4" |
| 5 Pressure adjuster | |

4.13.2 Priming pump



Before starting the burner, make sure that the tank return line is not clogged.

Obstructions in the line could cause the sealing organ located on the pump shaft to break.

- In order for the pump (Fig. 23) to be able to self-prime, the screw 4) must be loosened to purge the air in the suction line.
- Start the burner by closing the remote controls. As soon as the burner starts, check the direction of rotation of the fan blade.
- The pump can be considered to be primed when the light oil starts coming out of the screw 4).
- Close the burner and undo the screws 4).

The time required for this operation depends upon the diameter and length of the suction tubing.

If the pump fails to prime at first start-up and the burner locks out, wait approx. 15 seconds, reset the burner, and then repeat the start-up operation. And so on.

After 5 or 6 starting operations allow 2 or 3 minutes for the transformer to cool.

Do not illuminate the QRI cell or the burner will lock out; the burner should lock out anyway about 10 seconds after it starts.



The above-mentioned operation is possible because the pump is already full of fuel when it leaves the factory.

If the pump has been drained, fill it with fuel through the opening on the vacuum gauge 4)(Fig. 23) prior to starting; otherwise, the pump will seize.

Whenever the length of the suction piping exceeds 20-30 meters, the supply line must be filled using a separate pump.

4.14 Gas feeding



Explosion danger due to fuel leaks in the presence of a flammable source.

Precautions: avoid knocking, attrition, sparks and heat.

Make sure the fuel interception tap is closed before performing any operation on the burner.



WARNING

The fuel supply line must be installed by qualified personnel, in compliance with current standards and laws.

4.14.1 Gas feeding line (Example) - Please refer to the gas train documentation for more information

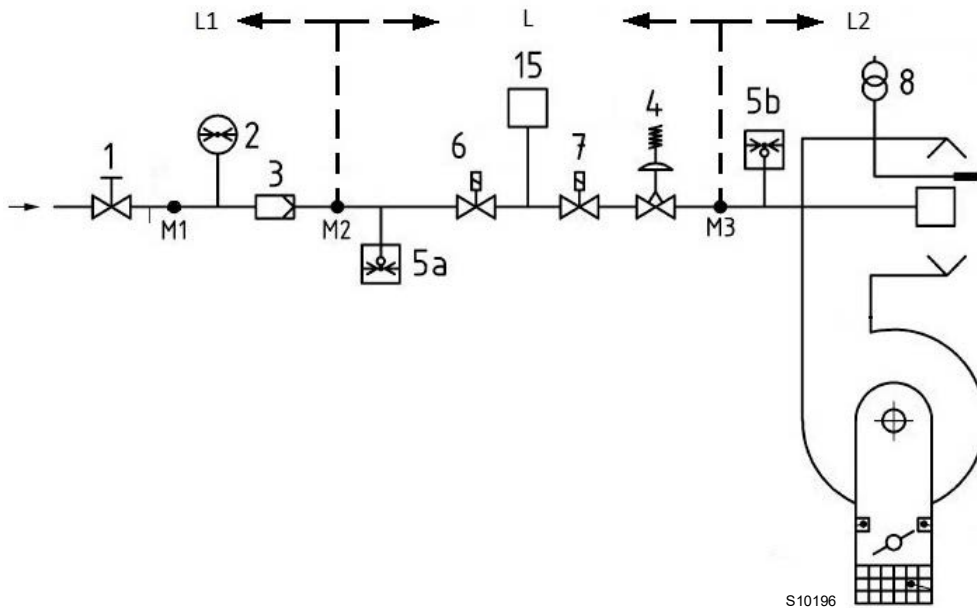

Fig. 24

Key (Fig. 24)

- 1 Manually operated shut-off valve
- 2 Pressure gauge
- 3 Filter
- 4 Governor
- 5a Low pressure protection device
- 5b Maximum gas pressure switch
- 6 1st safety shut-off device
- 7 2nd safety shut-off device
- 8 Ignition device
- 15 Valve leak detection control system
- L Gas train (supplied separately)
- L1 Responsibility of the installer
- L2 Burner
- M1 Pressure test point
- M2 Pressure test point
- M3 Pressure test point

4.14.2 Gas train

Approved according to standard EN 676 and provided separately from the burner.

4.14.3 Gas train installation



Disconnect the electrical power using the main switch.



Check that there are no gas leaks.



Pay attention when handling the train: danger of crushing of limbs.



Make sure that the gas train is properly installed by checking for any fuel leaks.



The operator must use the required equipment during installation.

The gas train is prearranged to be connected to the burner by the flange 1)(Fig. 25).

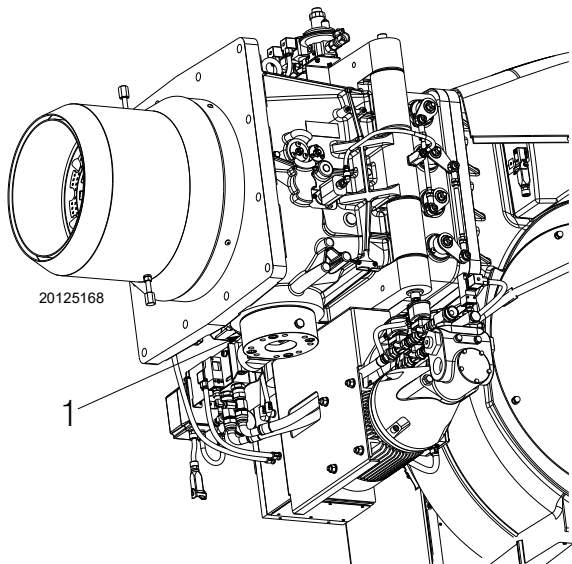

Fig. 25

4.14.4 Gas pressure

Tab. H indicates the pressure drop of the combustion head and the gas butterfly valve depending on the operating output of the burner.

kW	1 Δp (mbar)		2 Δp (mbar)	
	G 20	G 25	G 20	G 25
9500	60	89	17	25
10000	63	94	19	28
10500	69	103	21	31
11100	76	113	23	34
11600	84	125	25	37
12200	92	137	27	40
12700	101	150	29	43
13200	109	162	31	46
13700	116	173	33	49
14300	122	182	36	54

Tab. H



The data of thermal output and combustion head gas pressure are related to full open (90°) gas butterfly valve.

The values shown in Tab. H refer to:

- Natural gas G 20 NCV 9.45 kWh/Sm³ (8.2 Mcal/Sm³)
- Natural gas G 25 NCV 8.13 kWh/Sm³ (7.0 Mcal/Sm³)

Column 1

Combustion head pressure drop.

Gas pressure measured at test point 1)(Fig. 26), with:

- combustion chamber at 0 mbar;
- burner working at maximum modulating output;
- combustion head set as on page 20.

Column 2

Pressure loss at gas butterfly valve 2)(Fig. 26) with maximum opening: 90°.

To calculate the approximate output at which the burner operates:

- subtract the pressure in combustion chamber from the gas pressure measured at test point 1)(Fig. 26).
- Find, in Tab. H related to the burner concerned, the pressure value closest to the result of the subtraction.
- Read off the corresponding output on the left.

Example with natural gas G20:

Operation at maximum modulating output
 Gas pressure at test point 1)(Fig. 26) = 44.2 mbar
 Pressure in combustion chamber = 5 mbar
 44.2 - 5 = 39.2 mbar

A pressure of 39.2 mbar, column 1, corresponds in Tab. H to an output of 8000 kW.

This value serves as a rough guide; the effective output must be measured at the gas meter.

To calculate the required gas pressure at test point 1)(Fig. 26), set the maximum modulating output required from the burner operation:

- find the nearest output value in Tab. H for the burner in question.
- read, on the right (column 1), the pressure at the test point 1)(Fig. 26).
- Add this value to the estimated pressure in combustion chamber.

Example with natural gas G20:

Operation at maximum modulating output
 Gas pressure at an output of 8000kW = 39.2 mbar
 Pressure in combustion chamber = 5 mbar
 39.2 + 5 = 44.2 mbar
 pressure required at test point 1)(Fig. 26).

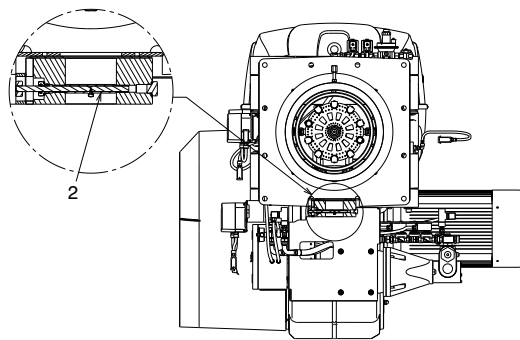

4.14.5 Pilot - gas train connection

The burner is fitted with a dedicated gas train that is fixed to the pipe coupling.

- It should be connected to the main train downstream the filter or the pressure adjuster (depending on configuration).



Supply pressure 68 ± 500 mbar.

4.14.6 Ignition pilot burner

For proper operation, adjust gas pressure (measured at pressure test point 1)(Fig. 27) as follows:

Model	Gas	mbar	Sm ³ /h
RLS 1300/EV C11	G20	26	19

Tab. I



Check pilot flame stability before starting up the main burner.

In the case of ignition problems check:

- correct positioning of the ignition electrode;
- the gas pressure, according to indications.

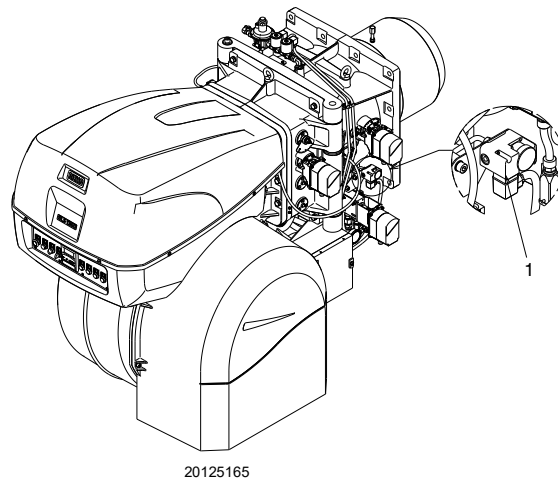

20125165

Fig. 26

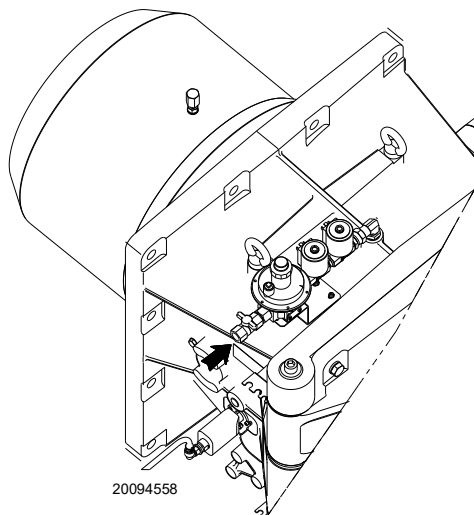

20094558

Fig. 27

4.15 Electrical wiring

Notes on safety for the electrical wiring



DANGER

- The electrical wiring must be carried out with the electrical supply disconnected.
- Electrical wiring must be made in accordance with the regulations currently in force in the country of destination and by qualified personnel. Refer to the wiring diagrams.
- The manufacturer declines all responsibility for modifications or connections different from those shown in the wiring diagrams.
- Check that the electrical supply of the burner corresponds to that shown on the identification label and in this manual.
- The burner has been type-approved for intermittent operation (FS1). This means that it should as a rule be stopped at least once every 24 hours to enable the flame control to perform checks of its own start-up efficiency. Normally, burner stopping is guaranteed by the boiler's thermostat/pressure switch. If this is not the case, a time switch should be fitted in series to TL to stop the burner at least once every 24 hours. Refer to the wiring diagrams.
- The burner is factory set for FS1 operation (1 stop every 24 hours); it can be converted to FS2 operation (continuous - 1 stop every 72 hours), by changing the parameters using the menu of the AZL Display.
- The electrical safety of the device is obtained only when it is correctly connected to an efficient earthing system, made according to current standards. It is necessary to check this fundamental safety requirement. In the event of doubt, have the electrical system checked by qualified personnel. Do not use the gas tubes as an earthing system for electrical devices.
- The electrical system must be suitable for the maximum power absorption of the device, as indicated on the label and in the manual, checking in particular that the section of the cables is suitable for that level of power absorption.
- For the main power supply of the device from the electricity mains:
 - do not use adapters, multiple sockets or extensions;
 - make provisions for an omnipolar switch with a gap between the contacts of at least 3 mm (over-voltage category III), as required by current safety regulations.
- Do not touch the device with wet or damp body parts and/or in bare feet.
- Do not pull the electric cables.

4.15.1 Notes on terminals

On the electrical panel there terminals with a "spring" system. The opening of these terminals must be made via a suitable tool, using a flat-blade screwdriver of the correct size.

The clamp uses a pressurised opening system.

Clamp opening

- insert the correct screwdriver into the opening, pushing down until the hole for the cable is completely open.
- Insert the previously stripped cable and remove the screwdriver. Make sure the cable is securely fastened Fig. 28.

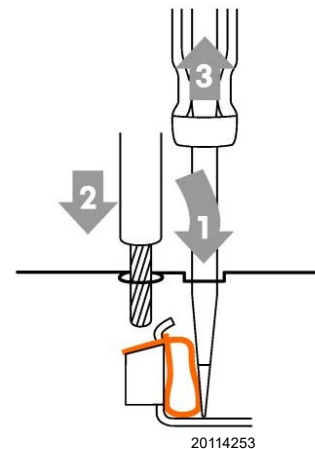

Fig. 28

Before carrying out any maintenance, cleaning or checking operations:



Turn off the burner's electrical supply using the main system switch.



Turn off the fuel interception tap.



Avoid condensate, ice and water leaks from forming.

If the cover is still present, remove it and proceed with the electrical wiring according to the wiring diagrams.

Use flexible cables in compliance with the EN 60 335-1 standard.

4.15.2 Supply cables and external connections passage

All the cables to be connected to the burner should be passed through cable grommets, as shown in Fig. 29.



To guarantee the protection level of the burner, it is necessary to close any holes and fairleads not used using the plugs supplied.

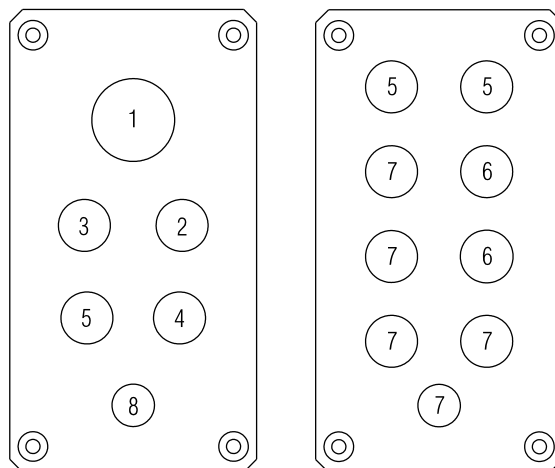

20096726

Fig. 29

Key (Fig. 29)

- 1 Electrical supply
- 2 Minimum gas pressure switch
- 3 Pressure switch for VPS gas valve leak detection
- 4 Gas train
- 5 Consents/Safety
- 6 Available
- 7 Plug
- 8 Rpm sensor cable outlet



After carrying out maintenance, cleaning or checking operations, reassemble the cover and all the safety and protection devices of the burner.

4.15.3 Shielding the connections



For the burner to operate correctly, where required, it is necessary to shield the connections.

WARNING

To shield the motor connection, proceed as follows:

- to access the motor casing, loosen the four screws 1)(Fig. 30) and remove the cover 2).



To make the correct shielding, it is important to bear in mind the necessary length of the connections inside the motor casing.

CAUTION

- Shield the cable 4) running from the VSD (inverter), as shown in Fig. 31 and using the coupling 3);
- install the cable 4) with its connection to the motor casing, securing it carefully.
- Carry out the motor connection as shown in the wiring diagrams.
- Fix the grommets/cable terminals of the connections securely and tidily to the terminal board of the motor.
- In the protective earth "PE" on the body of the fan motor, install the ground wire 5) fixing the eye 8) with the screw 6) outside the motor box putting the washers 7) in-between.
- Make a final visual check, then close the motor casing by tightening the 4 screws 1)(Fig. 30).

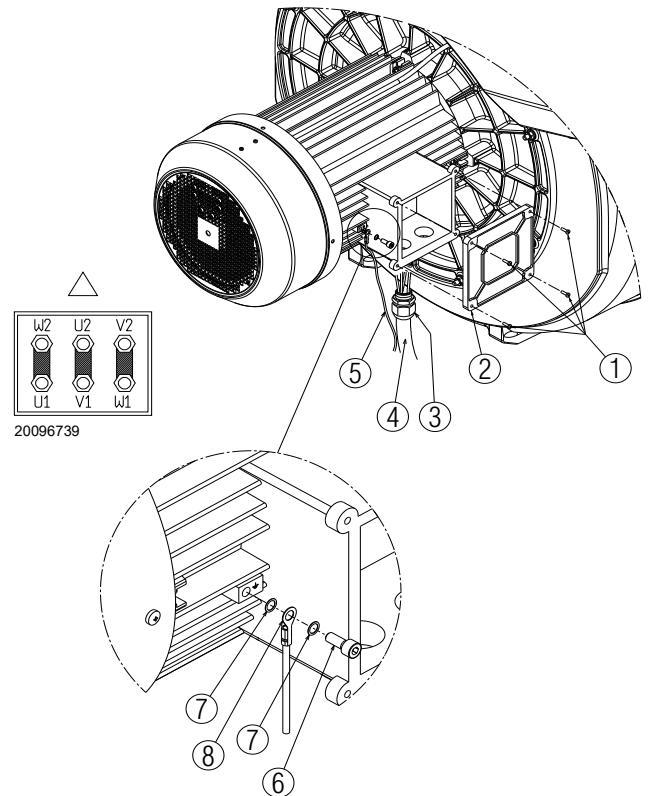

Fig. 30

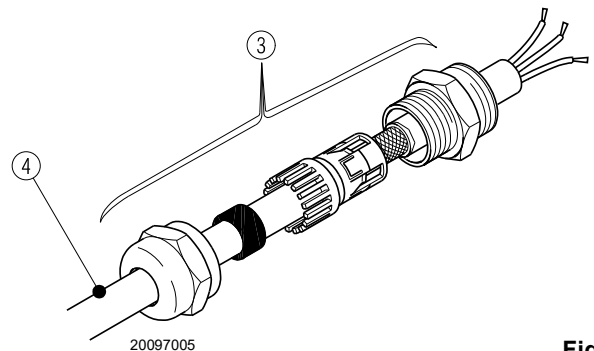

Fig. 31

4.16 Motor rotation

As the burner is not fitted with a phase sequence checking device, the motor rotation may be incorrect.



As soon as the burner starts up, go in front of the fan motor cooling fan and check it is rotating anti-clockwise (Fig. 32).

WARNING

If this is not the case:

- turn the burner switch to position "0" (OFF) and wait for the flame control to carry out the switch-off phase;
- disconnect the power supply to the main panel;
- invert the phases on the three-phase power supply.



This operation must be carried out with the electrical supply disconnected.

DANGER

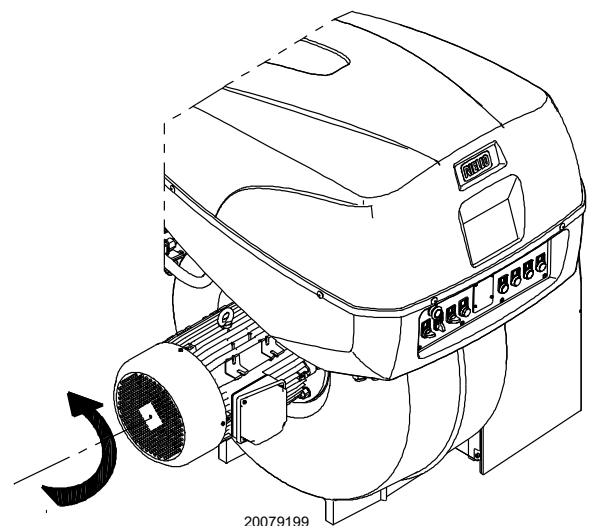

Fig. 32

4.17 Calibration of the thermal relay

The thermal relay (Fig. 33) serves to avoid damage to the motor due to an excessive absorption increase or if a phase is missing.

For calibration 2), refer to the table indicated in the electrical layout (electrical wiring in charge of the installer).

To reset, in case of an intervention of the thermal relay, press button "RESET" 1).

The button "STOP" 3) opens the NC contact (95-96) and stops the motor.

Insert a screwdriver in the window "TEST/TRIP" 4) and move it in the arrow direction (to the right) to carry out the thermal relay test.

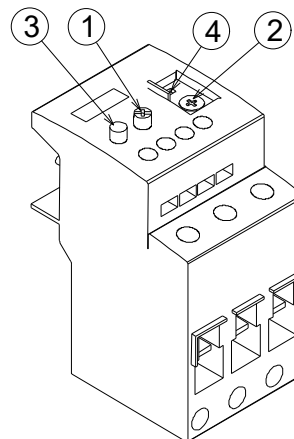

D11821



WARNING

The automatic reset can be dangerous.

This operation is not foreseen in the burner operation.

Fig. 33

5 Start-up, calibration and operation of the burner

5.1 Notes on safety for the first start-up



The first start-up of the burner must be carried out by qualified personnel, as indicated in this manual and in compliance with the standards and regulations of the laws in force.



Refer to paragraph “Safety test - with gas ball valve closed” on page 36.



Check the correct working of the adjustment, command and safety devices.

5.2 Adjustments prior to ignition (light oil)



It is recommended to adjust first the light oil burner and then the gas burner.

Carry out the fuel change with burner off.

The optimum calibration of the burner requires an analysis of the flue gases at the boiler outlet and interventions on the following points.

5.2.1 Nozzle

See information on page 19.

5.2.2 Combustion head

The adjustment of the combustion head already carried out on page 20 need not be altered unless the 2nd stage delivery of the burner is changed.

5.2.3 Pump pressure

In order to change pump pressure, act on screw 5)(Fig. 23). See information on page 19.

5.3 Burner ignition (light oil)

Position the selector 1)(Fig. 34) in “AUTO”.

Position the selector 2) in “OIL” to select light oil fuel.

When the limit thermostat (TL) is closed, the “HEAT REQUEST” 3) signal must be switched on.

At first ignition, there is a momentary drop in fuel pressure due to the filling of the nozzle piping. This lowering of the fuel pressure can cause the burner to lockout and can sometimes give rise to pulsations.

Once the following adjustments have been made, the ignition of the burner must generate a noise similar to the noise generated during operation.

If a burner lockout occurs, refer to the “Release procedure” given in the equipment manual supplied.

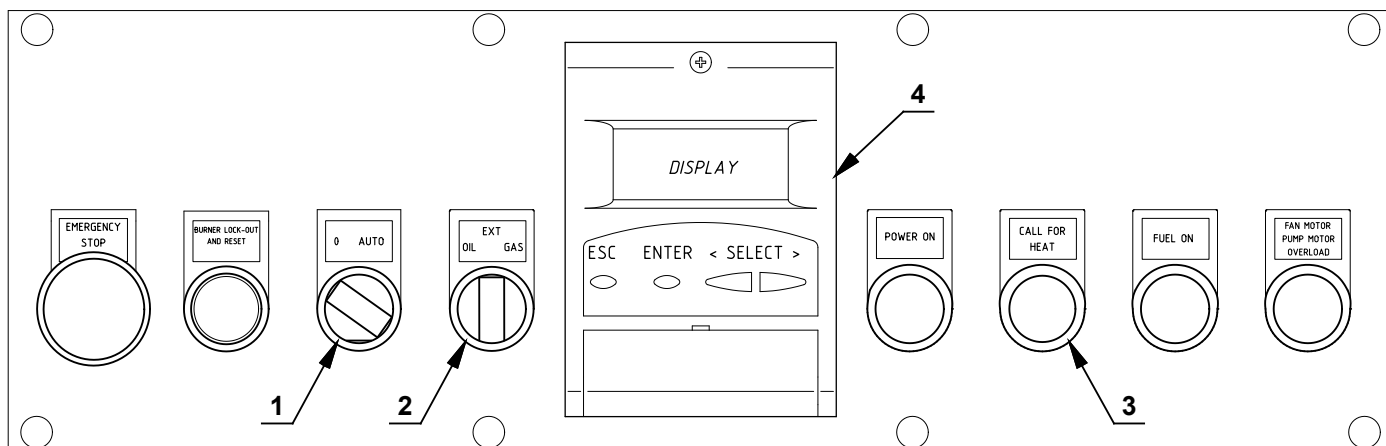

S8384

Fig. 34

5.4 Adjustments prior to ignition (gas)

In addition, the following adjustments must also be made:

- Slowly open the manual valves situated upstream from the gas train.
- Adjust the minimum gas pressure switch (Fig. 38) to the start of the scale.
- Adjust the maximum gas pressure switch (Fig. 37) to the end of the scale.
- Adjust the air pressure switch (Fig. 36) to the start of the scale.
- Purge the air from the gas line. We recommend using a plastic tube routed outside the building and to purge air until gas is smelt.
- Fit a U-type pressure gauge or a differential pressure gauge (Fig. 35), with socket (+) on the gas pressure of the pipe coupling and (-) in the combustion chamber. The manometer readings are used to calculate MAX burner output.
- Connect two lamps or testers to the two gas line solenoids to check the exact moment in which voltage is supplied. This operation is unnecessary if each of the two solenoid valves is equipped with a pilot light that signals voltage passing through.



Before starting up the burner, it is good practice to adjust the gas train so that ignition takes place in conditions of maximum safety, i.e. with gas delivery at the minimum.

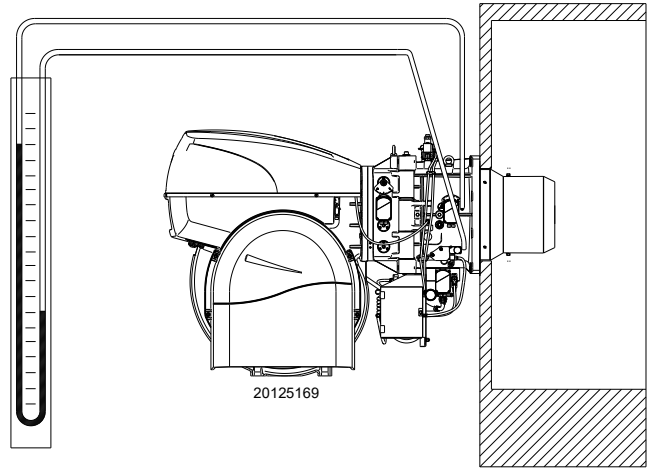

Fig. 35

5.5 Burner start-up (gas)

Close the remote controls and position the selector 1)(Fig. 34) to “**AUTO**”.

Position the selector 2) to “**GAS**” to select gas as fuel.

Make sure that the lights or testers connected to the solenoids, or the pilot lights on the solenoids themselves, indicate that no volt-

age is present. If voltage is present, stop the burner immediately and check the electrical connections.

When the limit thermostat (TL) closes, the “**CALL FOR HEAT**” 3) signal must come on. The burner will subsequently begin its starting cycle.

5.6 Burner ignition

The burner should light after having performed the above steps. If the motor starts up, but the flame does not appear and the flame control goes into lockout, reset it and wait for a new ignition attempt.

If ignition is still not achieved, it may be that gas is not reaching the combustion head within the safety time period of 3 seconds; In this case increase gas ignition delivery.

The arrival of gas at the sleeve is indicated by the U-type manometer (Fig. 35).

If further burner lockouts occur, refer to the “Release procedure” given in the equipment manual supplied.

Once the burner has fired, now proceed with global calibration operations.

5.7 Change of fuel

There are three options of change of fuel:

- 1 with the AZL device 4)(Fig. 34);
- 2 with selector 2);
- 3 with a remote selector connected to the main terminal board.

Positioning the selector 2)(Fig. 34) to “**EXT**” activates the remote selection of the fuel. In this position, if there is no remote selector, the AZL device defines the priority fuel and the selected fuel is shown on the display.

5.8 Combustion air adjustment

Fuel/combustion air synchronisation is done with the relevant servomotors (air and gas) by logging a calibration curve by means of the electronic cam.

It is advisable, to reduce the loss and for a wide calibration field, to adjust the servomotors to the maximum of the output used, the nearest possible to the maximum opening (90°).

On the gas butterfly valve, fuel step according to the burner output required, with servomotor completely open, is carried out by the pressure stabiliser placed on the gas train.

The values indicated in Tab. J and Tab. K can be a reference for a good combustion calibration.

EN 676		Air excess		CO
		Max. output $\lambda \leq 1.2$	Max. output $\lambda \leq 1.3$	
GAS	Theoretical max CO ₂ 0 % O ₂	CO ₂ % Calibration		mg/kWh
		$\lambda = 1.2$	$\lambda = 1.3$	
G 20	11.7	9.7	9	≤ 100
G 25	11.5	9.5	8.8	≤ 100
G 30	14.0	11.6	10.7	≤ 100
G 31	13.7	11.4	10.5	≤ 100

Tab. J

EN 267		Air excess		CO
		Max. output $\lambda \leq 1.2$	Min. output $\lambda \leq 1.3$	
Theoretical max CO ₂ 0 % O ₂		CO ₂ % Calibration		mg/kWh
		$\lambda = 1.2$	$\lambda = 1.3$	
15.2		12.6	11.5	≤ 100

Tab. K

5.8.1 Air / gas adjustment and output modulation

The air/gas adjustment and output modulation system with which the RLS range burners are equipped carries out a series of integrated functions in order to optimise burner functioning, both for single operation and together with other units (e.g. double furnace boiler or more than one generator in parallel).

The basic system functions control:

- 1 The dosage of the air and fuel through positioning using direct servo commands of the relevant valves eliminating the possible play in the calibration systems with mechanical cam lever mechanisms, used on traditional modulating burners.
- 2 The modulation of the burner output in accordance with the load required by the system, with maintenance of the pressure or temperature of the boiler at the operating values set.
- 3 The sequence (cascade adjustment) of more than one boiler through the suitable connection of the various units and the activation of the internal software of the individual systems (option).

Further interfaces and communication functions with computers, for remote control or integration in central supervision systems are available on the basis of the configuration of the system.



WARNING

The first start up and every further internal setting operation of the adjustment system or the expansion of the base functions require access by means of password and are to be carried out by service personnel who are especially trained for the internal programming of the instrument and the specific application created with this burner.

The first start-up and curve synchronisation manual is supplied with the burner.

At request, the complete manual for the control and setting of all parameters is available.

5.9 Pressure switch adjustment

5.9.1 Air pressure switch - check CO

Adjust the air pressure switch after performing all other burner adjustments with the air pressure switch set to the start of the scale (Fig. 36).

With the burner operating at MIN output, insert a combustion analyser in the stack, slowly close the suction inlet of the fan (for example, with a piece of cardboard) until the CO value does not exceed 100 ppm.

Slowly turn the appropriate knob clockwise until the burner goes into lockout.

Check the indication of the arrow pointing upwards on the graduated scale.

Turn the knob clockwise again, until the value shown on the graduated scale corresponds with the arrow pointing downwards, and so recovering the hysteresis of the pressure switch (shown by the white mark on a blue background, between the two arrows). Now check the correct start-up of the burner.

If the burner locks out again, turn the knob anticlockwise a little bit more.



Connecting the air pressure switch in differential mode, the burner will no longer be certified according to the EN 676 standard.

5.9.2 Maximum gas pressure switch

Adjust the maximum gas pressure switch (Fig. 37) after making all other burner adjustments with the maximum gas pressure switch set to the end of the scale.

To calibrate the maximum gas pressure switch, open the tap and then connect a pressure gauge to its pressure test point.

The maximum gas pressure switch must be regulated to a value no higher than 30% of the measurement read on the gauge when the burner is working at maximum output.

After making the adjustment, remove the pressure gauge and close the tap.

5.9.3 Minimum gas pressure switch

The purpose of the minimum gas pressure switch is to prevent the burner from operating in an unsuitable way due to too low gas pressure.

Adjust the minimum gas pressure switch (Fig. 38) after having adjusted the burner, the gas valves and the gas train stabiliser. With the burner operating at maximum output:

- install a pressure gauge downstream of the gas train stabiliser (for example at the gas pressure test point on the burner combustion head);
- choke slowly the manual gas cock until the pressure gauge detects a decrease in the pressure read of about 0.1 kPa (1 mbar). In this phase, verify the CO value which must always be less than 100 mg/kWh (93 ppm).
- Increase the adjustment of the gas pressure switch until it intervenes, causing the burner shutdown;
- remove the pressure gauge and close the cock of the gas pressure gauge used for the measurement;
- open completely the manual gas cock.



1 kPa = 10 mbar

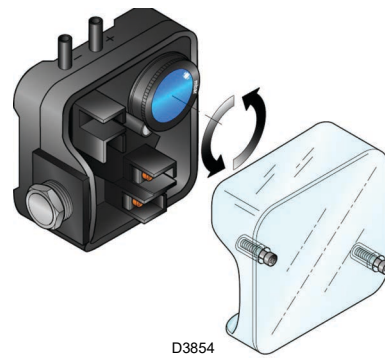

Fig. 36

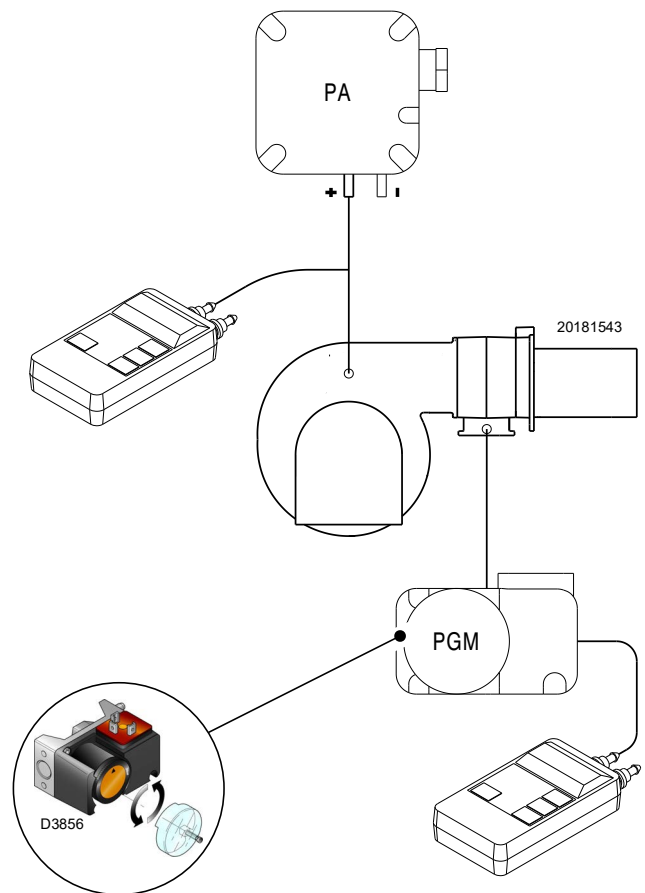

Fig. 37

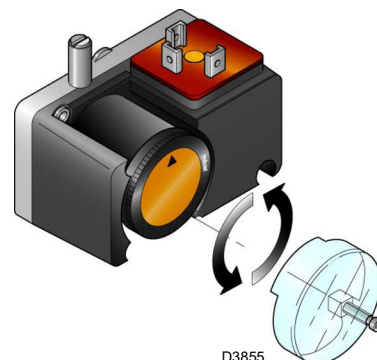

Fig. 38

5.9.4 PVP pressure switch kit

Adjust the pressure switch for the leak detection control (PVP kit) (Fig. 39) according to the instructions supplied with the kit.

5.9.5 Oil pressure switch

Check that the oil pressure switches have intervened correctly. Turn the adjustment screw (Fig. 40) to check that the pressure switches have intervened. The check should be carried out by individually varying the calibration of each pressure switch.

Decreasing the maximum calibration of the oil pressure switch, the burner should go into lockout.

Increasing the minimum calibration of the oil pressure switch, the burner should not start.

While the minimum oil pressure switch must be calibrated to approx. 16-18 bars.

With the control carried out, restore the factory setting of the maximum oil pressure switch to approx. 4-5 bar.

Any other pressure values should be adjusted to the burner output.

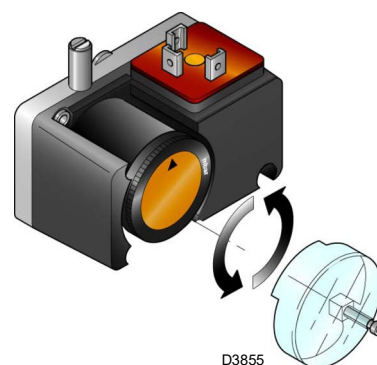

Fig. 39

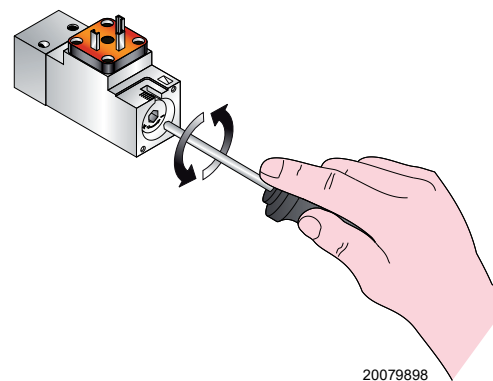

Fig. 40

5.10 Final checks (with burner operating)

<ul style="list-style-type: none"> ➤ Open the thermostat/pressure switch TL ➤ Open the thermostat/pressure switch TS 	➤	The burner must stop
<ul style="list-style-type: none"> ➤ Turn the gas maximum pressure switch knob to the minimum end of scale position ➤ Turn the air pressure switch to the maximum end of scale position 	➤	The burner must stop in lockout
<ul style="list-style-type: none"> ➤ Turn the oil maximum pressure switch knob to the minimum end of scale position ➤ Turn the oil minimum pressure switch knob to the maximum end of scale position 	➤	The burner must stop in lockout
<ul style="list-style-type: none"> ➤ Turn off the burner and cut off the power ➤ Disconnect the minimum gas pressure switch connector 	➤	The burner must not start
<ul style="list-style-type: none"> ➤ Disconnect the QRI flame sensor wire 	➤	The burner must stop in lockout due to ignition failure

Tab. L



Make sure that the mechanical locking systems on the various adjustment devices are fully tightened.

6 Maintenance

6.1 Notes on safety for the maintenance

The periodic maintenance is essential for the good operation, safety, yield and duration of the burner.

It allows you to reduce consumption and polluting emissions and to keep the product in a reliable state over time.



The maintenance interventions and the calibration of the burner must only be carried out by qualified, authorised personnel, in accordance with the contents of this manual and in compliance with the standards and regulations of current laws.

Before carrying out any maintenance, cleaning or checking operations:



Turn off the burner's electrical supply using the main system switch.



Turn off the fuel interception tap.



Wait for the components in contact with heat sources to cool down completely.

6.2 Maintenance programme

6.2.1 Maintenance frequency



The gas combustion system should be checked at least once a year by a representative of the manufacturer or another specialised technician.

6.2.2 Safety test - with gas ball valve closed

It is fundamental to ensure the correct execution of the electrical connections between the gas solenoid valves and the burner to perform safely the commissioning.

For this purpose, after checking that the connections have been carried out in accordance with the burner's electrical diagrams, an ignition cycle with closed gas ball valve -dry test- must be performed.

- 1 The manual ball gas valve must be closed
- 2 The electrical contacts of the burner limit switch need to be closed
- 3 Ensures closed the contact of the low gas pressure switch
- 4 Make a trial for burner ignition

The start-up cycle must be as follows:

- starting the fan for pre-ventilation
- Performing the gas valve seal control, if provided
- Completion of pre-ventilation
- Arrival of the ignition point
- Power supply of the ignition transformer
- Electrical Supply of solenoid gas valves

Since the manual gas ball valve is closed, the burner will not light up and its flame control will go to a safety lockout condition.

The actual electrical supply of the solenoid gas valves can be verified by inserting a tester. Some valves are equipped with light signals (or close/open position indicator) that turn on at the same time as their power supply.



IF THE ELECTRICAL SUPPLY OF THE GAS VALVES OCCURS AT UNEXPECTED TIMES, DO NOT OPEN MANUAL GAS BALL VALVE, SWITCH OFF POWER LINE; CHECK THE WIRES; CORRECT THE ERRORS AND REPEAT THE COMPLETE TEST.

6.2.3 Checking and cleaning



The operator must use the required equipment during maintenance.

Combustion

The optimum calibration of the burner requires an analysis of the flue gases.

Significant differences with respect to the previous measurements indicate the points where most care should be exercised during maintenance.

Combustion head

Open the burner and make sure that all components of the combustion head are in good condition, not deformed by the high temperatures, free of impurities from the surroundings and correctly positioned.

Fan

Check to make sure that no dust has accumulated inside the fan or on its impellers, as this condition will cause a reduction in the air flow rate and provoke polluting combustion.

Boiler

Clean the boiler as indicated in its accompanying instructions in order to maintain all the original combustion characteristics intact, especially: the flue gas temperature and combustion chamber pressure.

Voltage on the QRI flame sensor

Minimum value for correct operation: 3.5V DC (value on AZL display at about 50%).

If the value is lower, it could be due to:

- flame sensor not positioned correctly
- low voltage (lower than 187V)
- bad regulation of the burner

In order to measure, use a voltmeter with a 10V DC scale connected as in the diagram (Fig. 41).

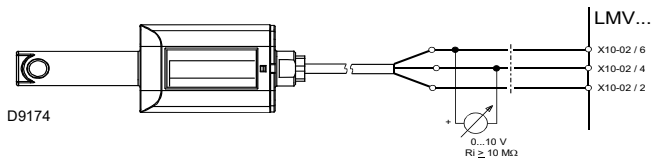

Fig. 41

Burner

Clean the outside of the burner.

6.2.4 Safety components

The safety components should be replaced at the end of their life cycle indicated in the following table.

The specified life cycles do not refer to the warranty terms indicated in the delivery or payment conditions.

Safety component	Life cycle
Flame control	10 years or 250.000 operation cycles
Flame sensor	10 years or 250.000 operation cycles
Gas valves (solenoid)	10 years or 250.000 operation cycles
Pressure switches	10 years or 250.000 operation cycles
Pressure adjuster	15 years
Servomotor (electronic cam) (if present)	10 years or 250.000 operation cycles
Oil valve (solenoid) (if present)	10 years or 250.000 operation cycles
Oil regulator (if present)	10 years or 250.000 operation cycles
Oil pipes/ couplings (metallic) (if present)	10 years
Fan impeller	10 years or 500.000 start-ups

Tab. M

6.2.5 Electrical panel



Turn off the burner's electrical supply using the main system switch.

In the event of maintenance/replacement of components in the lower part of the electrical panel, access is possible via the front of the panel itself, following the directions below:

- unscrew the screws 2) of the control panel 1);
- extract the control panel 1) and turn it 90°, hooking it with the brackets 3) in the profile of the electrical panel as shown in Fig. 42;
- after performing the operation, install the control panel 1) in the electrical panel with the appropriate screws 2), arranging the cables present.



Failure to install the control panel 1) in the seat of the electrical panel, results in the machine's loss of "IP" protection.

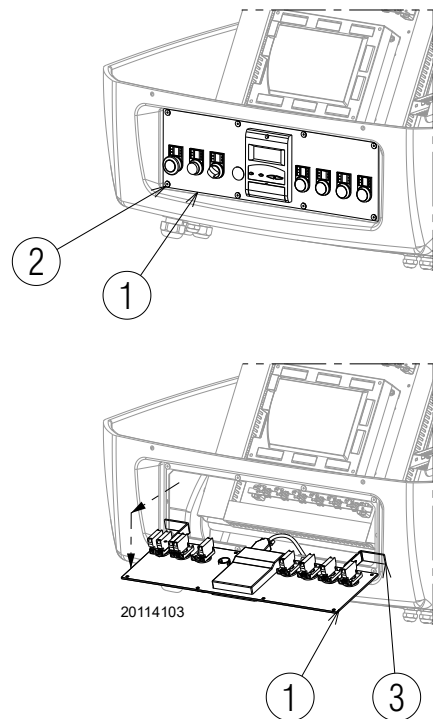

Fig. 42

6.3 Checking the position of the rpm sensor

To calibrate the rpm sensor 6)(Fig. 43), proceed as follows:

- remove the cover 1) unscrewing the screws 2);
- unscrew or screw the nuts 3) - 5) and the rpm detection disc 4) so that its distance from the rpm sensor 6) is about 2 mm.;
- place the plate 4) on the nut 5) and fix with the lock nut 3);
- close the cover 1) by screwing the screws 2).

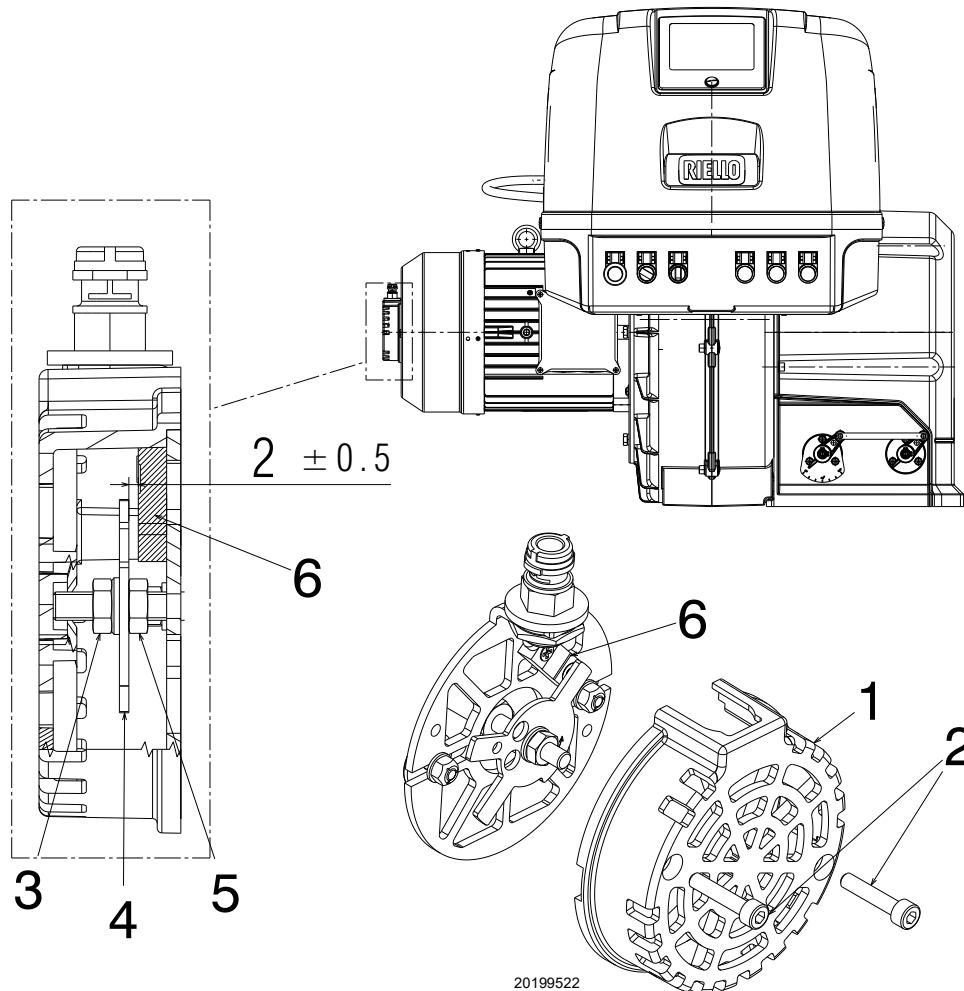

Fig. 43

Key (Fig. 43)

- 1 Cover
- 2 Screws for cover fixing
- 3 Lock nut
- 4 Rpm detection disc
- 5 Lower nut
- 6 Rpm sensor

6.3.1 Pump unit



WARNING

Prior to performing any operations/maintenance on the pump unit, make sure the electrical power supply to the burner is turned off by means of the system's main switch.

LIGHT OIL OPERATION

GAS OPERATION

Pump

The pressure going in should conform to the values in the chart Fig. 16.

The depression must be less than 0.45 bar.

Unusual noise must not be evident during pump operation.

If the pressure is unstable, or the pump runs noisily, the flexible hose must be detached from the line filter and the fuel must be sucked from a tank located near the burner. This measure permits the cause of the anomaly to be traced to either the suction line or the pump. If the problem lies in the suction line, check the filter is clean and that air is not entering the piping.

Filters

Check the filtering baskets on line 1)(Fig. 44) and at nozzle 2) present in the system. Clean or replace if necessary. If rust or other impurities are observed inside the pump, use a separate pump to lift any water and other impurities that may have deposited on the bottom of the tank.

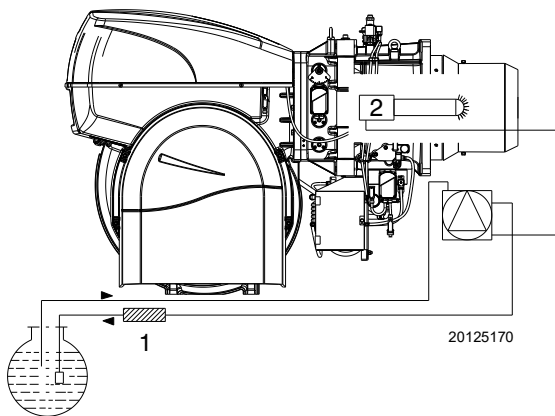

Fig. 44

Nozzles

It is advisable to replace nozzles every year during regular maintenance operations. Do not clean the nozzle openings;

Hoses

Check that these are in good conditions.

Fuel tank

Approximately every 5 years, suck any water on the bottom of the tank using a separate pump.

Combustion

In case the combustion values found at the beginning of the intervention do not respect the standards in force or, in any case, do not correspond to a proper combustion, contact the Technical Assistance Centre in order to carry out the necessary adjustments.

Gas leaks

Make sure that there are no gas leaks on the pipe between the gas meter and the burner.

Gas filter

Change the gas filter when it is dirty.

Combustion

In case the combustion values found at the beginning of the intervention do not respect the standards in force or, in any case, do not correspond to a proper combustion, contact the Technical Assistance Centre in order to carry out the necessary adjustments.

EN 676		Air excess		CO
		Max. output $\lambda \leq 1.2$	Max. output $\lambda \leq 1.3$	
GAS	Theoretical max CO ₂ 0 % O ₂	CO ₂ % Calibration		mg/kWh
		$\lambda = 1.2$	$\lambda = 1.3$	
G 20	11.7	9.7	9	≤ 100
G 25	11.5	9.5	8.8	≤ 100
G 30	14.0	11.6	10.7	≤ 100
G 31	13.7	11.4	10.5	≤ 100

Tab. O

EN 267	Air excess		CO
	Max. output $\lambda \leq 1.2$	Min. output $\lambda \leq 1.3$	
Theoretical max CO ₂ 0 % O ₂	CO ₂ % Calibration		mg/kWh
	$\lambda = 1.2$	$\lambda = 1.3$	
15.2	12.6	11.5	≤ 100

Tab. N

6.4 Opening the burner



Turn off the burner's electrical supply using the main system switch.



Turn off the fuel interception tap.



Wait for the components in contact with heat sources to cool down completely.

- Disconnect the socket 1)(Fig. 45) of the oil/gas servomotor;
- Disconnect the socket of the derivation unit.
- Disconnect the flame sensor.
- Disconnect the electrode connection from the transformer, see procedure in chapter Access to head internal part;
- Remove the screws 2).

At this point, it is possible to open the burner on the hinge.

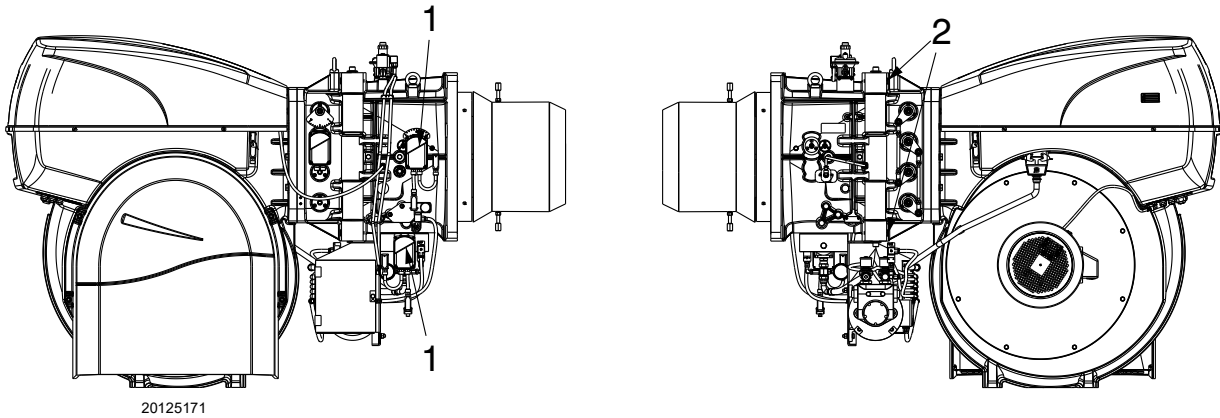

20125171

Fig. 45

6.5 Closing the burner

Refit following the steps described but in reverse order; refit all burner components as they were originally assembled.



After carrying out maintenance, cleaning or checking operations, reassemble the cover and all the safety and protection devices of the burner.

7 Faults - Probable causes - Solutions

If faults arise in ignition or operations, the burner performs a "safety stop", which is signalled by the red burner lockout LED.

The display visualises alternately the lockout code and the relative diagnostic. To reset the start-up conditions, refer to the "Reset procedure" indicated in the flame control manual supplied.

When the burner starts again, the red LED goes out and the flame control is reset.



WARNING

In the event the burner stops, in order to prevent any damage to the installation, do not unblock the burner more than twice in a row. If the burner locks out for a third time, contact the customer service.



DANGER

In the event there are further lockouts or faults with the burner, the maintenance interventions must only be carried out by qualified, authorised personnel, in accordance with the contents of this manual and in compliance with the standards and regulations of current laws.

A Appendix - Accessories**Probe for checking temperature/pressure**

Parameter to be checked		Probe	
	Adjustment field	Type	Code
Temperature	- 100...+ 500 °C	PT 100	3010110
Pressure	0...2.5 bar	Output probe 4....20 mA	3010213
	0...16 bar		3010214

AZL Kit (display and operating unit) - (Russia only)

Burner	Code
RLS 1300/EV C11	3010469

Pressure switch kit for leak detection control (supplied as standard)

Burner	Code
RLS 1300/EV C11	3010344

Software interface kit

Burner	Code
RLS 1300/EV C11	3010388

Kit O₂

Burner	Code
RLS 1300/EV C11	20045187

Inverter Kit

Burner	Code
RLS 1300/EV C11	20030338



The use of inverters other than those indicated by the manufacturer may lead to burner failure and, in extreme cases, a potential risk of harm to people and damage to property. The manufacturing company shall not be liable for any such damage arising from non-observance of the requirements contained in this manual.

C9 Soundproofing box kit

Burner	Code
RLS 1300/EV C11	20108736

Flue gases sensor bracket kit

Burner	Code
RLS 1300/EV C11	20041585

Air/combustion fume temperature sensor

Parameter to be checked		Probe	
	Adjustment field	Type	Code
Temperature	- 100...+ 500 °C	PT 1000Ni1000	3010377

Gas trains in compliance with EN 676

Please refer to manual.

B Appendix - Electrical panel layout

1	Index of layouts
2	Indication of references
3	Single-wire output layout
4	Fuel selection functional layout
5	LMV52.... functional layout
6	LMV52.... functional layout
7	LMV52.... functional layout
8	LMV52.... functional layout
9	LMV52.... functional layout
10	LMV52.... functional layout
11	LMV52.... functional layout
12	LMV52.... functional layout
13	Electrical wiring that the installer is responsible for
14	Electrical wiring that the installer is responsible for
15	Electrical wiring that the installer is responsible for

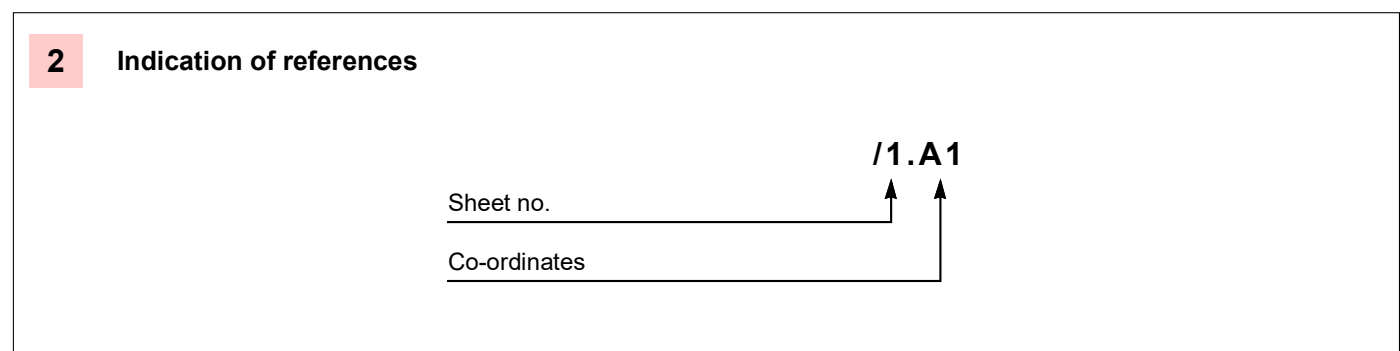

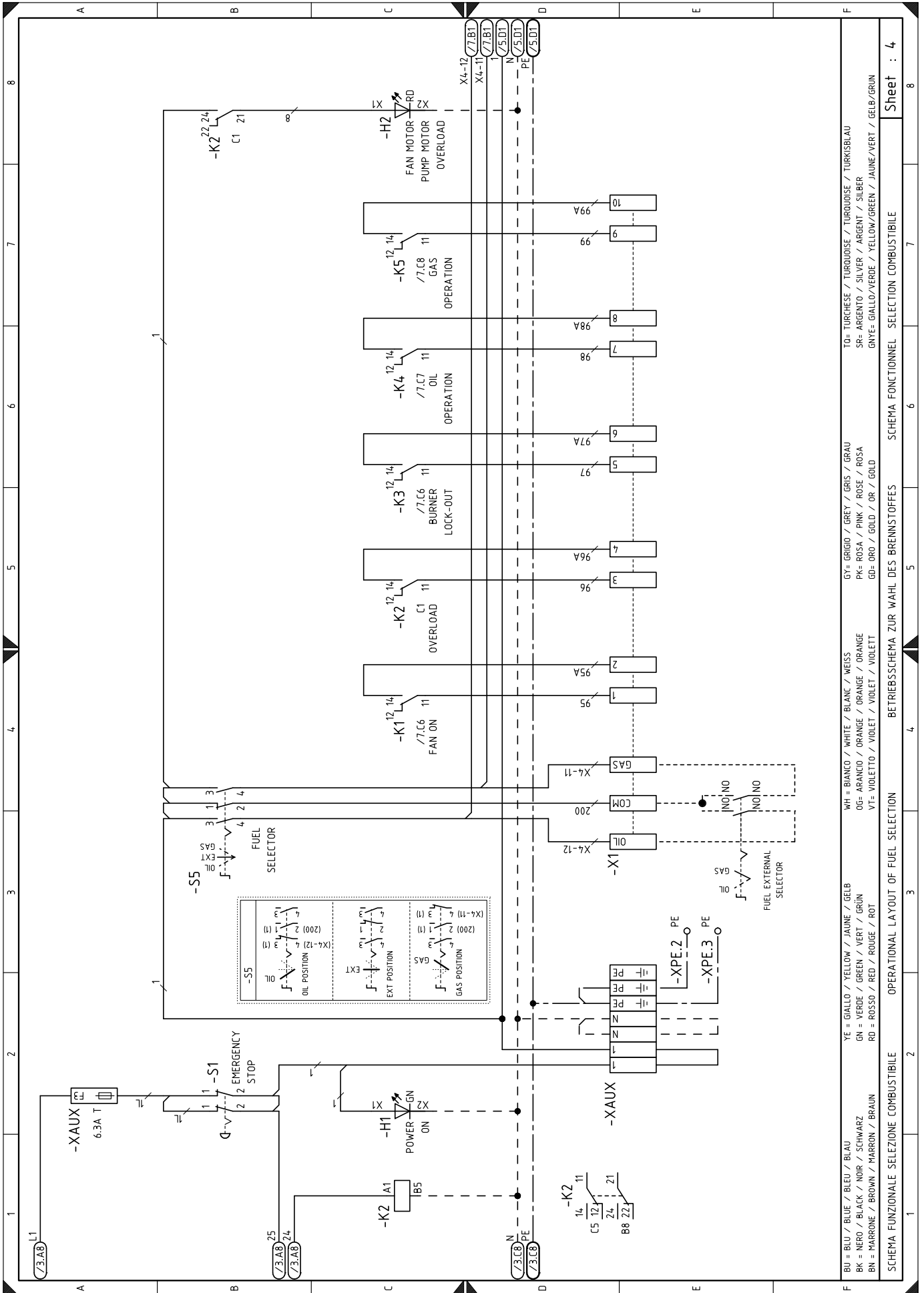

BU = BLU / BLUE / BLEU / BLAU
 BK = NERO / BLACK / NOIR / SCHWARZ
 BN = MARRONE / BROWN / MARRON / BRAUN
 YE = GIALLO / YELLOW / JAUNE / GÉLBE
 GN = VERDE / GREEN / VERT / GRÜN
 RD = ROSSO / RED / ROUGE / ROT
 WH = BIANCO / WHITE / BLANC / WEISS
 OG= ARANCIO / ORANGE / ORANGE / ORANGE
 VT= VIOLETTO / VIOLET / VIOLET / VIOLETT
 GY= GRIGIO / GREY / GRIS / GRAU
 PK= ROSA / PINK / ROSE / ROSA
 GO= ORO / GOLD / OR / GOLD
 SR= ARGENTO / SILVER / ARGENT / SILBER
 GNVE= GIALLO/VERDE / YELLOW/GREEN / JAUNE/VERT / GÉLBE/GRÜN
 TO= TURCHESE / TURQUOISE / TURQUOISE / TURKISBLAU

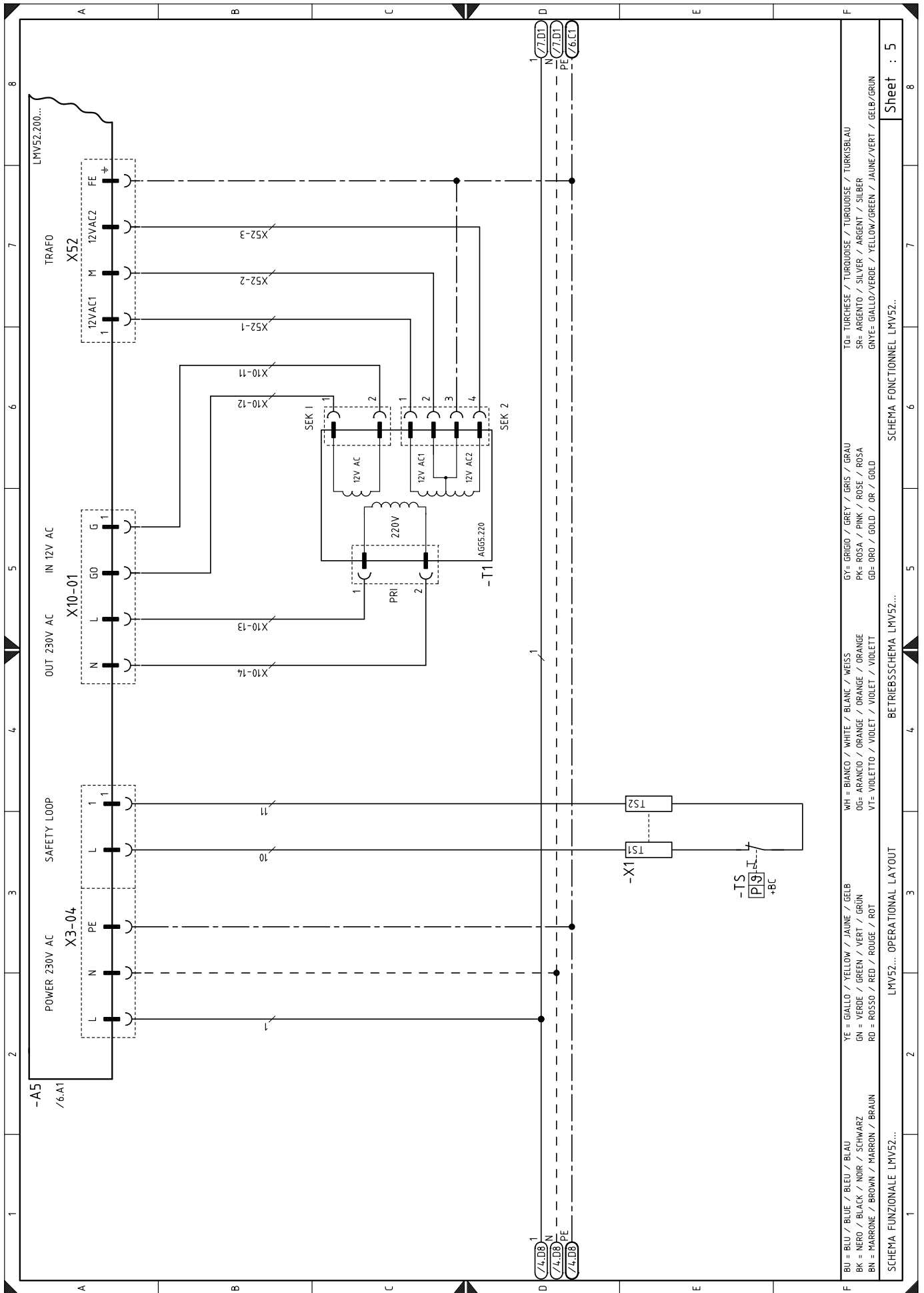

Sheet : 5

SCHEMA FUNZIONALE LMV52...
 SCHEMA FONCTIONNEL LMV52...
 BETRIEBSSCHEMA LMV52...
 LMV52... OPERATIONAL LAYOUT

WH = BIANCO / WHITE / BLANC / WEISS
 O5= ARANCIO / ORANGE / ORANGE / ORANGE
 V7= VIOLETT / VIOLET / VIOLET / VIOLETT

GY= GRIGIO / GREY / GRIS / GRAU
 PK= ROSA / PINK / ROSE / ROSA
 GD= ORO / GOLD / OR / GOLD

TO= TURCHESE / TURQUOISE / TURQUOISE / TURKISBLAU
 SR= ARGENTO / SILVER / ARGENT / SILBER
 GNYE= GIALLO/VERDE / YELLOW/GREEN / JAUNE/VERT / GELB/GRUN

YE = GIALLO / YELLOW / JAUNE / GELB
 GN = VERDE / GREEN / VERT / GRUN
 RD = ROSSO / RED / ROUGE / ROT

BU = BLU / BLUE / BLEU / BLAU
 BK = NERO / BLACK / NOIR / SCHWARZ
 BN = MARRONE / BROWN / MARRON / BRAUN

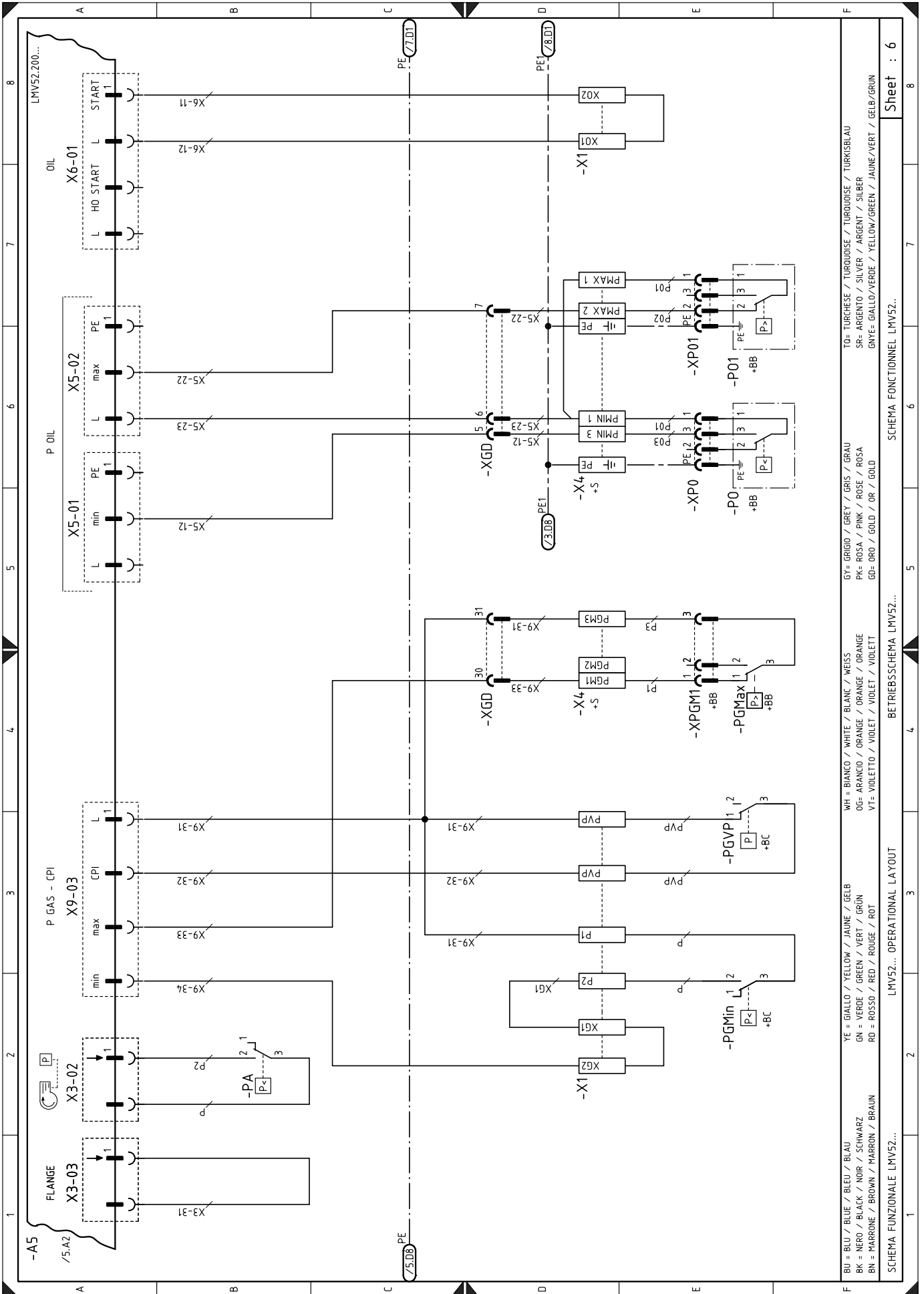

Sheet : 6

SCHEMA FONCTIONNEL LMV52...

BETRIEBSSCHEMA LMV52...

OPERATIONAL LAYOUT LMV52...

SCHEMA FUNZIONALE LMV52...

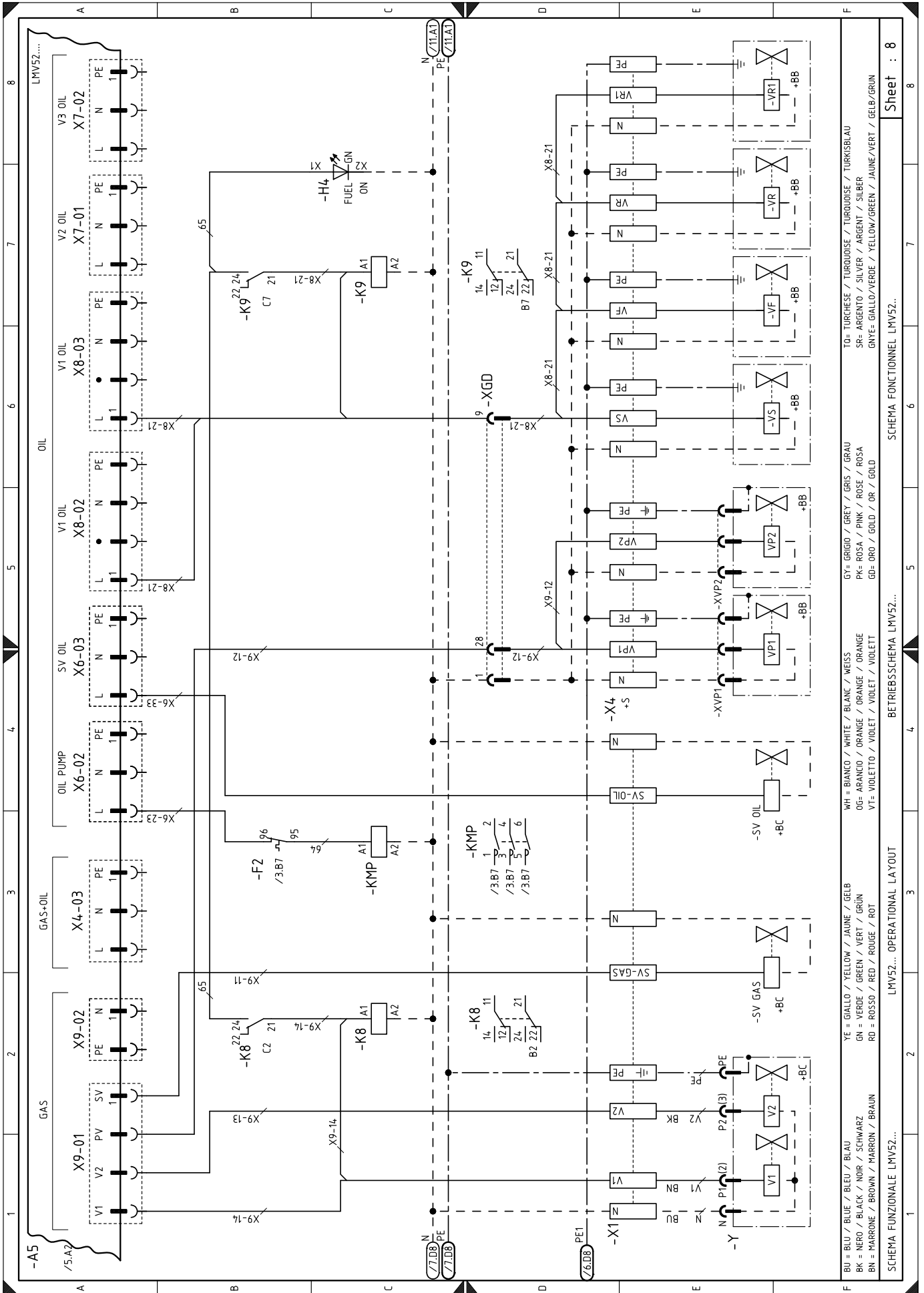

TO= TURCHESE / TURQUOISE / TURQUOISE / TURQUOISE / TURKISBLAU
 SR= ARGENTO / SILVER / ARGENT / SILBER
 GNYE= GIALLO/VERDE / YELLOW/GREEN / JAUNE/VERT / GELB/GRÜN

GY= GRIGIO / GREY / GRIS / GRAU
 WH= BIANCO / WHITE / BLANC / WEISS
 OG= ARANCIO / ORANGE / ORANGE / ORANGE
 PK= ROSA / PINK / ROSE / ROSA
 GD= ORO / GOLD / OR / GOLD

YE= GIALLO / YELLOW / JAUNE / GÉLB
 GN= VERDE / GREEN / VERT / GRÜN
 RD= ROSSO / RED / ROUGE / ROT

BU= BLU / BLUE / BLEU / BLAU
 BK= NERO / BLACK / NOIR / SCHWARZ
 BN= MARRONE / BROWN / MARRON / BRAUN

LMV52... OPERATIONAL LAYOUT

LMV52... BETRIEBSSCHEMA LMV52...

SCHEMA FONCTIONNEL LMV52...

Sheet : 8

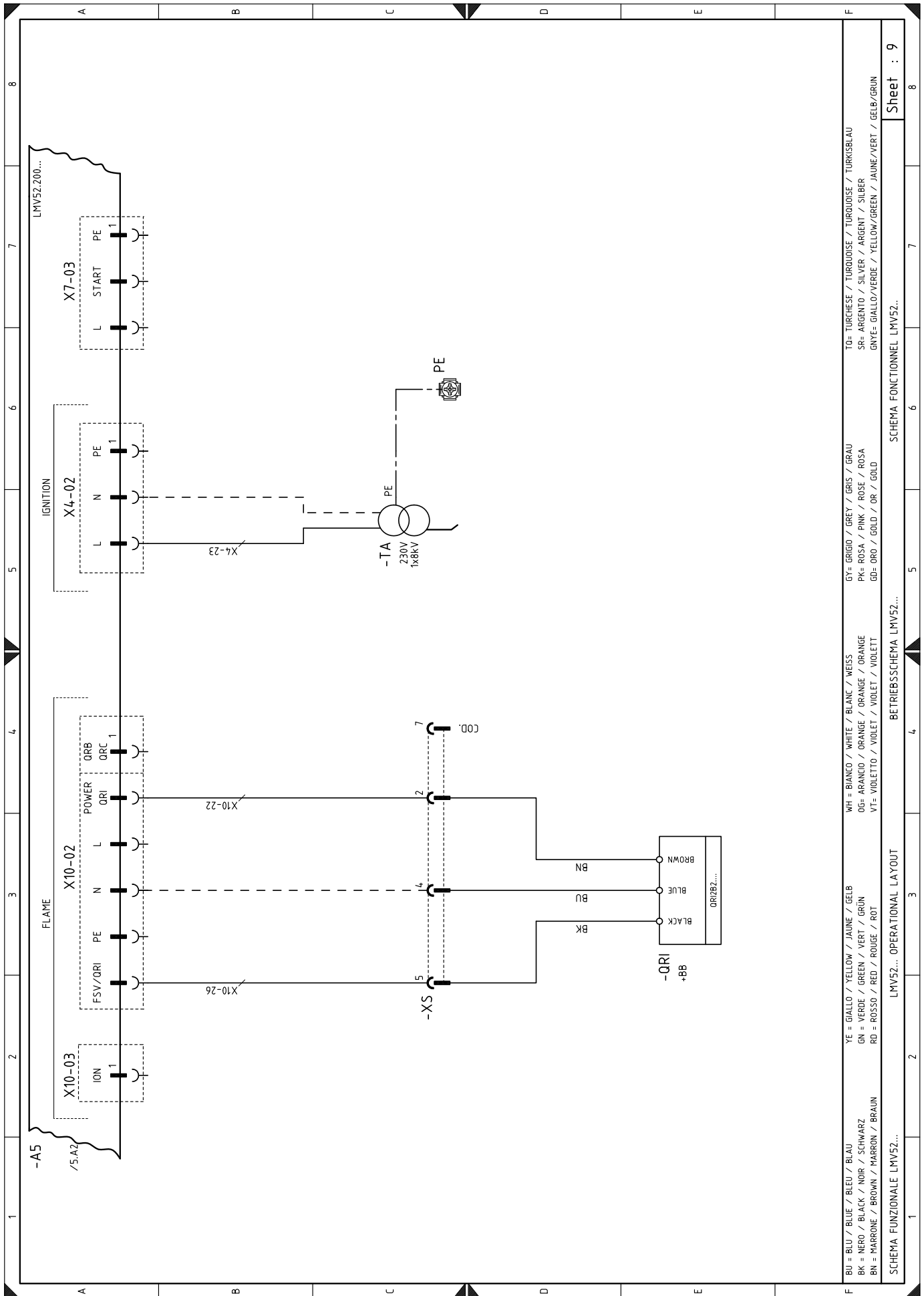

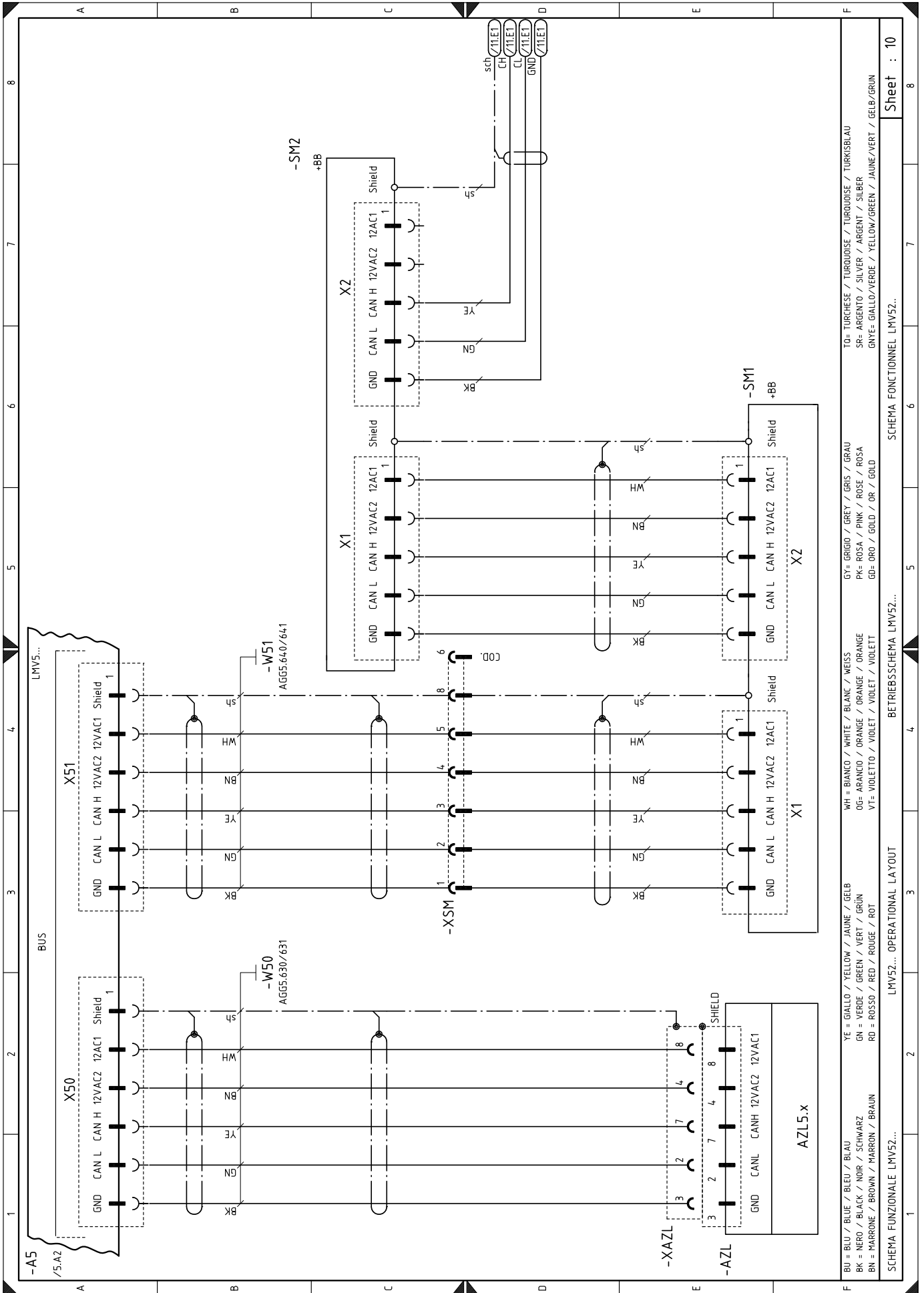

TO= TURCHESE / TURQUOISE / TURQUOISE / TURKISBLAU
 SR= ARGENTO / SILVER / ARGENT / SILBER
 GNYE= GIALLO/VERDE / YELLOW/GREEN / JAUNE/VERT / GELB/GRUN

GY= GRIGIO / GREY / GRIS / GRAU
 PK= ROSA / PINK / ROSE / ROSA
 GD= ORO / GOLD / OR / GOLD

WH = BIANCO / WHITE / BLANC / WEISS
 OG= ARANCIO / ORANGE / ORANGE / ORANGE
 VT= VIOLETTO / VIOLET / VIOLET / VIOLETT

YE = GIALLO / YELLOW / JAUNE / GELB
 GN = VERDE / GREEN / VERT / GRUN
 RD = ROSSO / RED / ROUGE / ROT

BK = BLU / BLUE / BLEU / BLAU
 BK = NERO / BLACK / NOIR / SCHWARZ
 BN = MARRONE / BROWN / MARRON / BRAUN

Sheet : 10

SCHEMA FONCTIONNEL LMV52...

BETRIEBSSCHEMA LMV52...

LMV52... OPERATIONAL LAYOUT

SCHEMA FUNZIONALE LMV52...

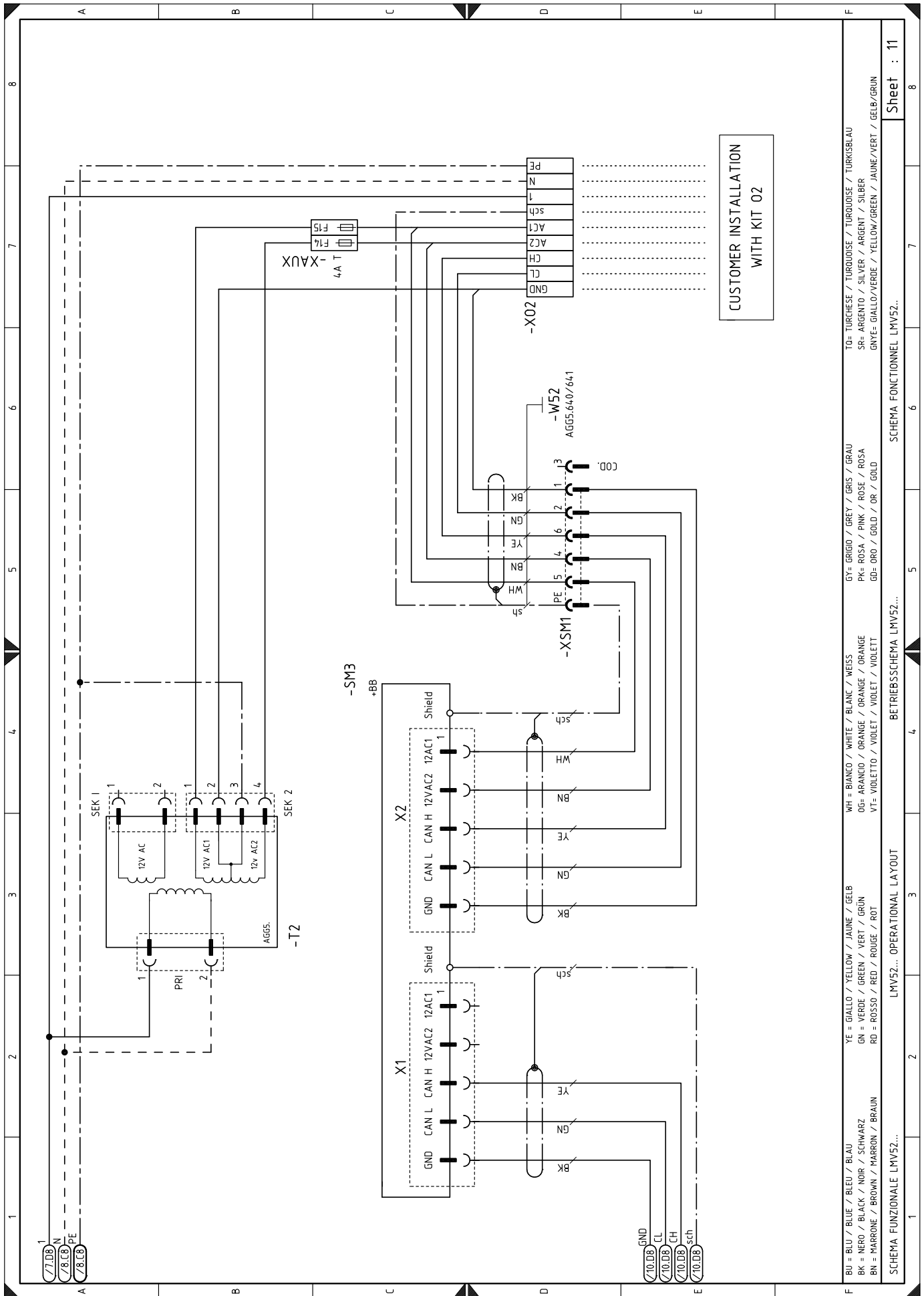

F BU = BLU / BLUE / BLEU / BLAU
 BK = NERO / BLACK / NOIR / SCHWARZ
 BN = MARRONE / BROWN / MARRON / BRAUN
 YE = GIALLO / YELLOW / JAUNE / GELB
 GN = VERDE / GREEN / VERT / GRÜN
 RD = ROSSO / RED / ROUGE / ROT
 WH = BIANCO / WHITE / BLANC / WEISS
 OG= ARANCIO / ORANGE / ORANGE / ORANGE
 VF= VIOLETT / VIOLET / VIOLET / VIOLETT
 GY= GRIGIO / GREY / GRIS / GRAU
 PK= ROSA / PINK / ROSE / ROSA
 GD= ORO / GOLD / OR / GOLD
 TO= TURCHESE / TURQUOISE / TURQUOISE / TURKISBLAU
 SR= ARGENTO / SILVER / ARGENT / SILBER
 GNYE= GIALLO/VERDE / YELLOW/GREEN / JAUNE/VERT / GELB/GRÜN

LMV52... OPERATIONAL LAYOUT
 BTRIEBSSCHEMA LMY52...
 SCHEMA FONCTIONNEL LMY52...
 SCHEMA FUNZIONALE LMY52...

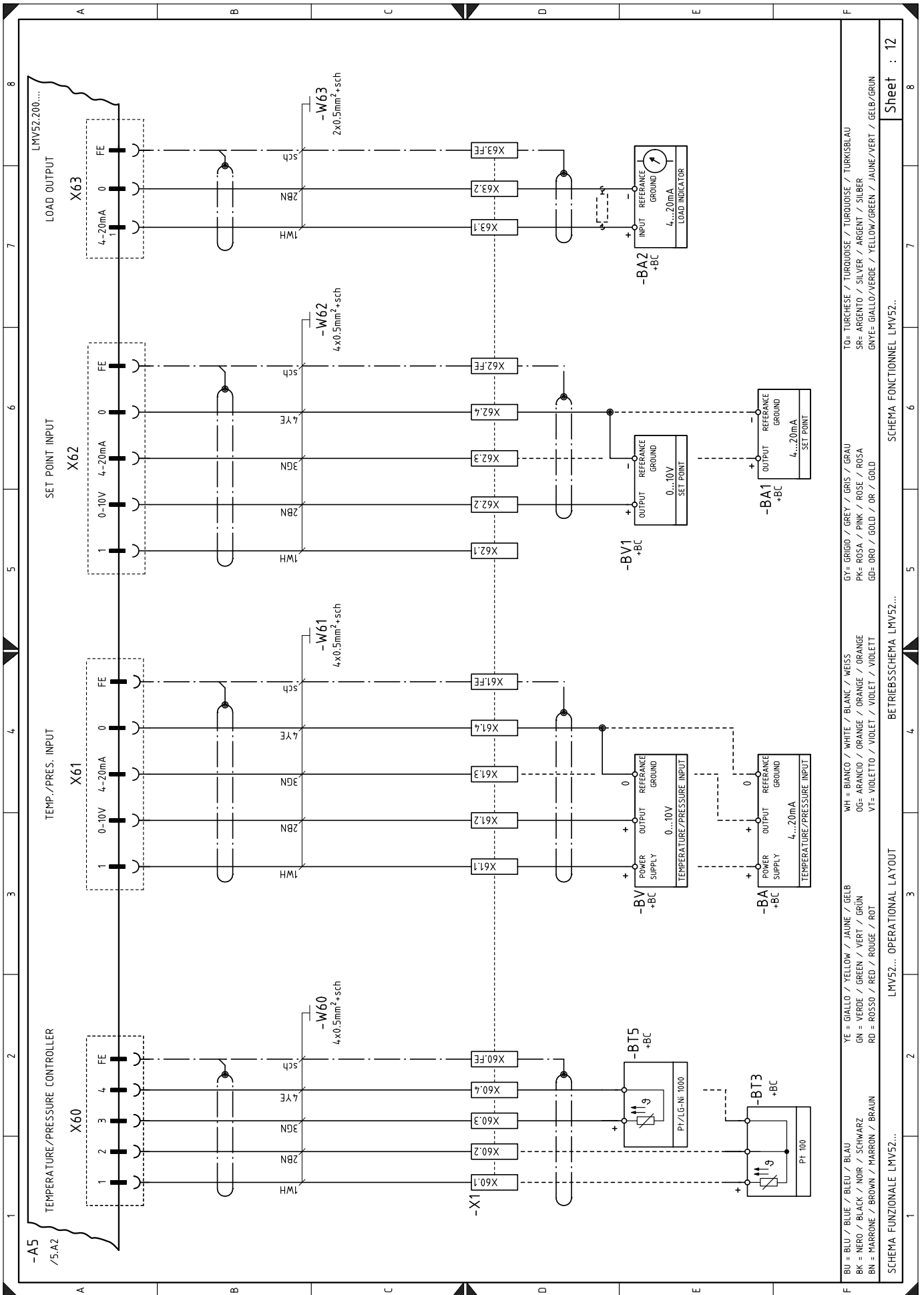

Sheet : 12

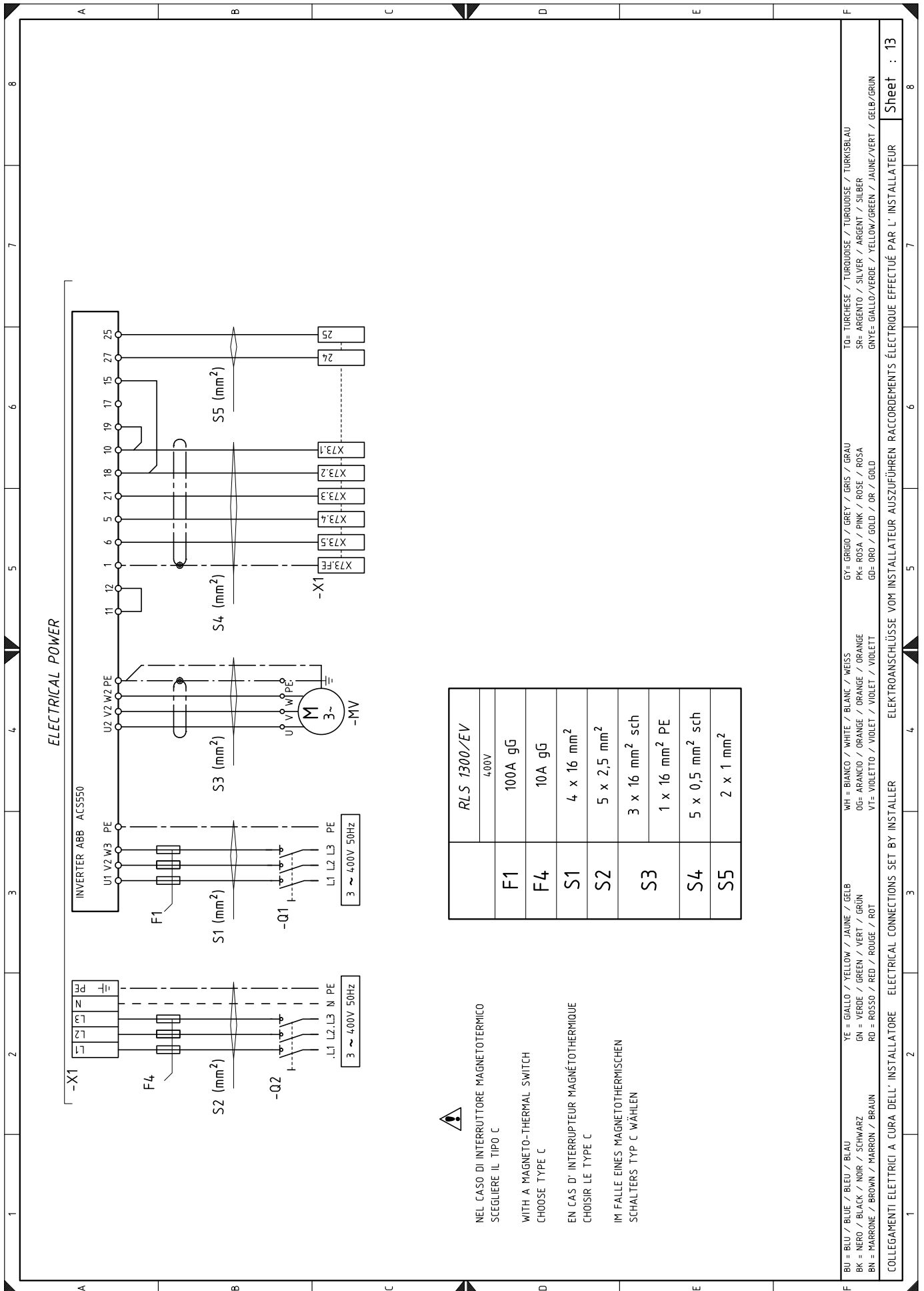

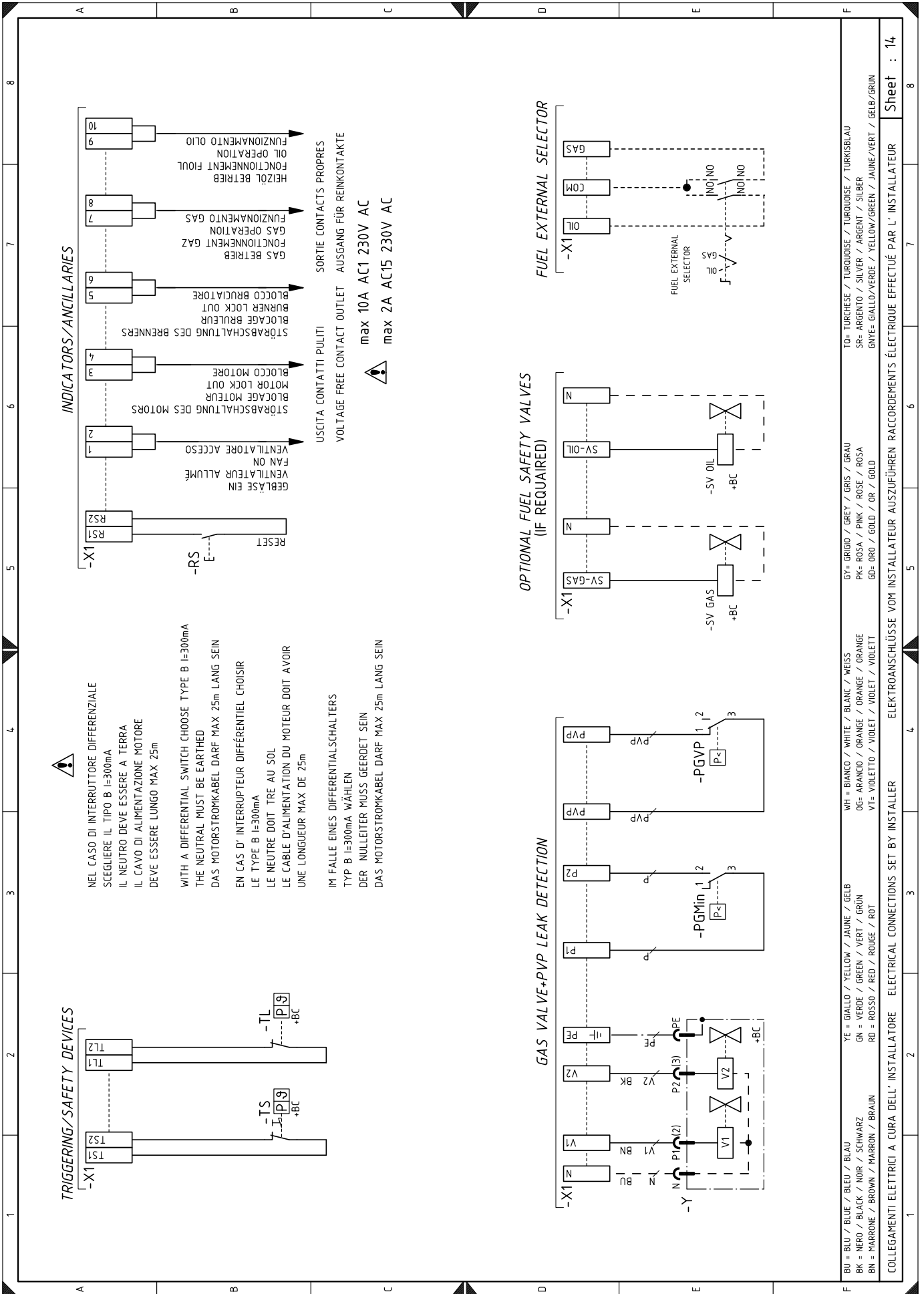

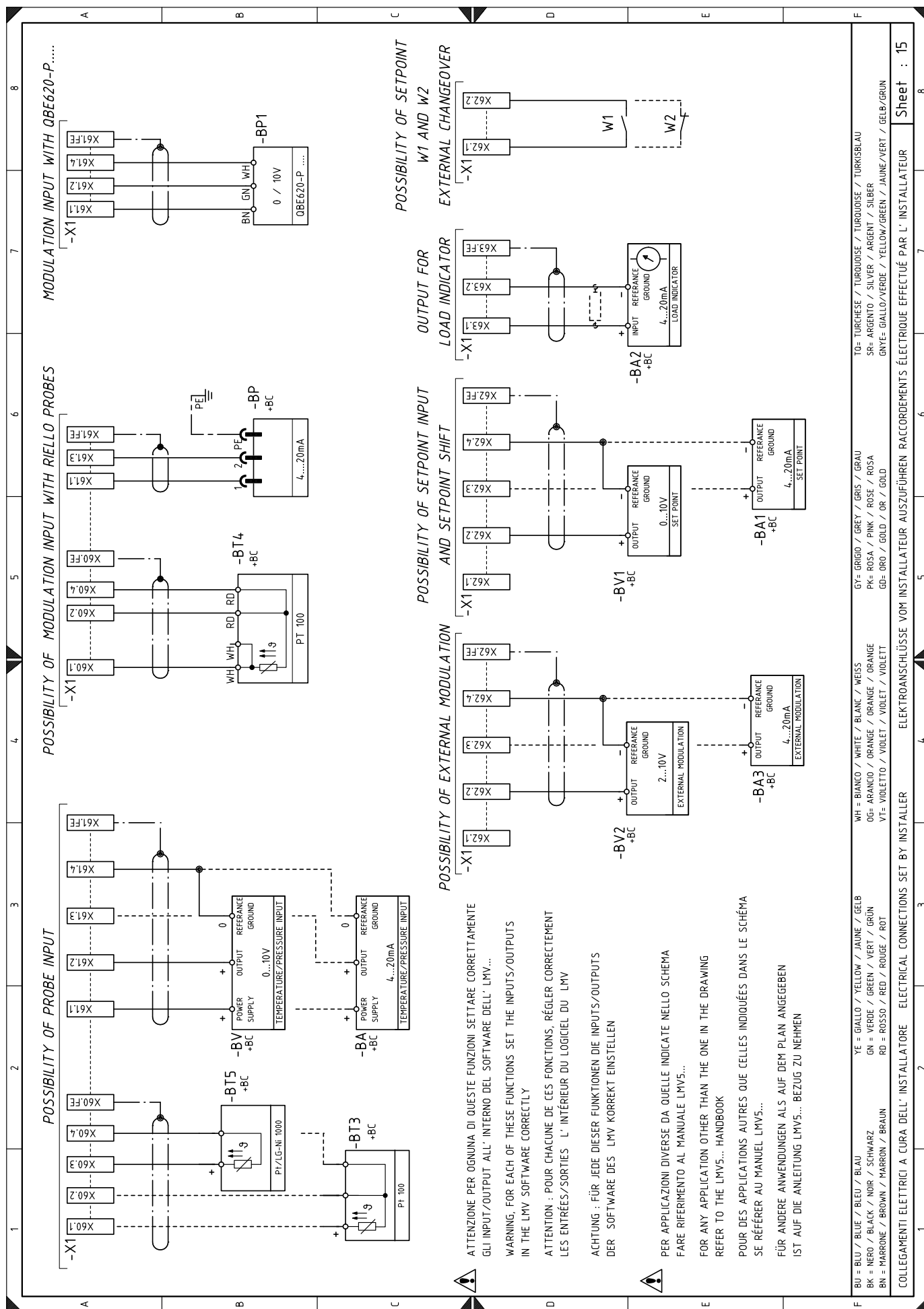

Wiring layout key

A5	Flame control	VR1	Light oil return valve
AZL	Display for flame control	VS	Safety light oil valve
BA	Output probe in current	XAZL	AZL display connector
BA1	Output device in current to modify remote setpoint	XAUX	Auxiliary terminal board
BA2	Load indicator with input under current	XGD	Derivation unit connector
BA3	Device with current output for remote modulation	XPGM	Maximum gas pressure switch connector
BP	Pressure probe	XPO	Oil pressure switch connector
BP1	Pressure probe	XPO1	Oil return pressure switch connector
BT3	Probe Pt100, 3 wires	XS	Flame sensor connector
BT4	Probe Pt100, 3 wires	XSM	Servomotor connector SM1
BT5	PT 1000 probe, 2 wires	XSM1	Servomotor connector SM3
BV	Output probe in voltage	X1	Main terminal supply board
BV1	Output device in voltage to modify remote setpoint	X4	Derivation unit terminal board
BV2	Device with voltage current output for remote modulation	X02	Kit O ₂ terminal board
F1	Inverter line fuse	X70	RPM sensor terminal board
F2	Pump motor thermal relay	XVP1	Pilot valve 1 connector
F3	Auxiliary fuse	XVP2	Pilot valve 2 connector
F4	Three-phase line fuse	Y	Gas regulator valve + gas safety valve
F14	Fuse T2		
F15	Fuse T2		
GF	Inverter		
G2	Rpm sensor		
H1	Light signalling burner on		
H2	Light signalling fan motor and pump motor lockout		
H3	Heat request lighting signal		
H4	Fuel supply light signal		
KMP	Pump motor contact maker		
K1	Clean contacts output relay with fan motor working		
K2	Volt-free overload contacts output relay		
K3	Clean contacts output relay burner lockout		
K4	Output relay for light oil operation clean contacts		
K5	Output relay for gas operation clean contacts		
K8	Clean contacts output relay burner switched on gas		
K9	Clean contacts output relay burner switched on		
MP	Pump motor		
MV	Fan motor		
PA	Air pressure switch		
PE	Burner earth		
PGMAX	Maximum gas pressure switch		
PGMin	Minimum gas pressure switch		
PGVP	Pilot valves gas pressure switch		
PO	Oil pressure switch		
PO1	Maximum oil pressure switch on return line		
Q1	Inverter power supply disconnect switch		
Q2	Line disconnect switch		
QRI	Flame sensor		
RS	Remote burner reset button		
S1	Emergency stop button		
S2	0 / AUTO selector		
S5	Fuel selector and enable signal to remote fuel selector		
SH3	Burner reset button and lock-out signal		
SM1	Servomotor		
SM2	Fuel servomotor		
SM3	Head movement servomotor		
SV gas	External gas safety valve		
SV oil	Remote safety light oil valve		
TA	Ignition transformer		
TL	Limit thermostat/pressure switch		
TS	Safety thermostat/pressure switch		
T1	Flame control transformer		
T2	Transformer servomotors		
VF	Light oil operation valve		
VP1	Pilot valve 1		
VP2	Pilot valve 2		
VR	Light oil return valve		

RIELLO

RIELLO S.p.A.
I-37045 Legnago (VR)
Tel.: +39.0442.630111
[http:// www.riello.it](http://www.riello.it)
[http:// www.riello.com](http://www.riello.com)