

GB **Forced draught gas burner**

Progressive two-stage or modulating operation



CODE	MODEL
20142732	RS 190/EV MZ



Original instructions

1	Information and general warnings.....	3
1.1	Information about the instruction manual	3
1.1.1	Introduction.....	3
1.1.2	General dangers.....	3
1.1.3	Other symbols	3
1.1.4	Delivery of the system and the instruction manual	4
1.2	Guarantee and responsibility.....	4
2	Safety and prevention.....	5
2.1	Introduction.....	5
2.2	Personnel training	5
3	Technical description of the burner	6
3.1	Burner designation	6
3.2	Models available.....	6
3.3	Burner categories - Countries of destination	6
3.4	Technical data	7
3.5	Maximum dimensions.....	7
3.6	Firing rate	8
3.7	Test boiler.....	8
3.8	Burner equipment.....	8
3.9	Burner components	9
3.10	Flame control (REC 37.400A2)	10
3.11	Operation sequence of the burner.....	13
3.11.1	List of phases	14
3.12	Operator panel operation	14
3.12.1	Symbols description on the display	14
3.12.2	Buttons description.....	15
3.13	Servomotors (SQM33....)	16
4	Installation	17
4.1	Notes on safety for the installation	17
4.2	Handling	17
4.3	Preliminary checks	17
4.4	Operating position	18
4.5	Preparing the boiler	18
4.5.1	Boring the boiler plate	18
4.5.2	Blast tube length.....	18
4.6	Positioning probe - electrode.....	19
4.7	Securing the burner to the boiler	20
4.8	Combustion head adjustment.....	21
4.9	Burner closing	22
4.10	Gas feeding	23
4.10.1	Gas feeding line (Example) - Please refer to the gas train documentation for more information.....	23
4.10.2	Gas train.....	24
4.10.3	Gas train installation.....	24
4.10.4	Gas pressure.....	24
4.11	Electrical wiring	26
4.11.1	Supply cables and external connections passage	26
4.11.2	Motor cable shield	27
4.12	Adjustment fan motor covering with external rpm	28
5	Start-up, calibration and operation of the burner	29
5.1	Notes on safety for the first start-up	29
5.2	Adjustments prior to ignition	29
5.3	Burner start-up	30
5.4	Burner adjustment	30
5.4.1	Firing output	30

5.4.2	Maximum output	30
5.4.3	Minimum output	30
5.5	Final calibration of the pressure switches	31
5.5.1	Air pressure switch.....	31
5.5.2	Maximum gas pressure switch.....	31
5.5.3	Minimum gas pressure switch.....	32
5.5.4	PVP pressure switch kit	32
5.6	Visualisation and programming mode.....	33
5.6.1	Normal mode	33
5.6.2	Info mode	35
5.6.3	Service mode	35
5.6.4	Parameters Mode	36
5.7	Parameter modification procedure.....	37
5.7.1	Procedure for inserting and adjusting points on the modulation curve	37
5.7.2	CALC function.....	38
5.7.3	Modification of parameter "acceleration / deceleration ramp"	38
5.8	Start-up procedure	39
5.9	Backup / Restore procedure	41
5.9.1	Backup	41
5.9.2	Restore	42
5.9.3	Parameter list.....	43
5.10	Steady-state operation.....	47
5.11	Ignition failure.....	48
5.12	Burner flame goes out during operation.....	48
5.13	Stopping of the burner	48
5.14	Final checks (with burner operating).....	48
6	Maintenance	49
6.1	Notes on safety for the maintenance	49
6.2	Maintenance programme	49
6.2.1	Maintenance frequency.....	49
6.2.2	Safety test - with gas ball valve closed	49
6.2.3	Checking and cleaning.....	49
6.2.4	Safety components	50
6.2.5	Measuring the ionisation current.....	50
6.2.6	Checking the air and gas pressure on the combustion head	50
6.3	Opening the burner	51
6.4	Closing the burner.....	51
7	Faults - Probable causes - Solutions	52
7.1	Error codes list.....	52
A	Appendix - Accessories	61
B	Appendix - Electrical panel layout.....	62

1 Information and general warnings

1.1 Information about the instruction manual

1.1.1 Introduction

The instruction manual supplied with the burner:

- is an integral and essential part of the product and must not be separated from it; it must therefore be kept carefully for any necessary consultation and must accompany the burner even if it is transferred to another owner or user, or to another system. If the manual is lost or damaged, another copy must be requested from the Technical Assistance Service of the area;
- is designed for use by qualified personnel;
- offers important indications and instructions relating to the installation safety, start-up, use and maintenance of the burner.

Symbols used in the manual

In some parts of the manual you will see triangular DANGER signs. Pay great attention to these, as they indicate a situation of potential danger.

1.1.2 General dangers

The **dangers** can be of **3 levels**, as indicated below.



Maximum danger level!
This symbol indicates operations which, if not carried out correctly, cause serious injury, death or long-term health risks.



This symbol indicates operations which, if not carried out correctly, may cause serious injury, death or long-term health risks.



This symbol indicates operations which, if not carried out correctly, may cause damage to the machine and/or injury to people.

1.1.3 Other symbols



DANGER: LIVE COMPONENTS
This symbol indicates operations which, if not carried out correctly, lead to electric shocks with lethal consequences.



DANGER: FLAMMABLE MATERIAL
This symbol indicates the presence of flammable materials.



DANGER: BURNING
This symbol indicates the risks of burns due to high temperatures.



DANGER: CRUSHING OF LIMBS
This symbol indicates the presence of moving parts: danger of crushing of limbs.



WARNING: MOVING PARTS
This symbol indicates that you must keep limbs away from moving mechanical parts; danger of crushing.



DANGER: EXPLOSION

This symbol signals places where an explosive atmosphere may be present. An explosive atmosphere is defined as a mixture - under atmospheric conditions - of air and flammable substances in the form of gases, vapours, mist or dust in which, after ignition has occurred, combustion spreads to the entire unburned mixture.



PERSONAL PROTECTION EQUIPMENT

These symbols indicate the equipment that must be worn and kept by the operator for protection against threats against safety and/or health while at work.



OBLIGATION TO ASSEMBLE THE HOOD AND ALL THE SAFETY AND PROTECTION DEVICES

This symbol signals the obligation to reassemble the hood and all the safety and protection devices of the burner after any maintenance, cleaning or checking operations.



ENVIRONMENTAL PROTECTION

This symbol gives indications for the use of the machine with respect for the environment.



IMPORTANT INFORMATION

This symbol indicates important information that you must bear in mind.

- This symbol indicates a list.

Abbreviations used

Ch.	Chapter
Fig.	Figure
Page	Page
Sec.	Section
Tab.	Table

1.1.4 Delivery of the system and the instruction manual

When the system is delivered, it is important that:

- the instruction manual is delivered to the user by the system manufacturer, with the recommendation to keep it in the room where the heat generator is to be installed.
- The instruction manual shows:
 - the serial number of the burner;

.....

- the address and telephone number of the nearest Assistance Centre.

.....

- The system supplier must carefully inform the user about:
 - the use of the system;
 - any further tests that may be required before activating the system;
 - maintenance, and the need to have the system checked at least once a year by a representative of the manufacturer or another specialised technician.
 To ensure a periodic check, the manufacturer recommends the drawing up of a Maintenance Contract.

1.2 Guarantee and responsibility

The manufacturer guarantees its new products from the installation date, in accordance with the regulations in force and/or the sales contract. At the moment of the first start-up, check that the burner is integral and complete.



WARNING

Failure to observe the information given in this manual, operating negligence, incorrect installation and carrying out of non authorised modifications will result in the annulment by the manufacturer of the guarantee that it supplies with the burner.

In particular, the rights to the guarantee and the responsibility will no longer be valid, in the event of damage to things or injury to people, if such damage/injury was due to any of the following causes:

- incorrect installation, start-up, use and maintenance of the burner;
- improper, incorrect or unreasonable use of the burner;
- intervention of unqualified personnel;
- carrying out of unauthorised modifications on the equipment;
- use of the burner with safety devices that are faulty, incorrectly applied and/or not working;
- installation of untested supplementary components on the burner;
- powering of the burner with unsuitable fuels;
- faults in the fuel supply system;
- use of the burner even following an error and/or an irregularity;
- repairs and/or overhauls incorrectly carried out;
- modification of the combustion chamber with inserts that prevent the regular development of the structurally established flame;
- insufficient and inappropriate surveillance and care of those burner components most likely to be subject to wear and tear;
- the use of non-original components, including spare parts, kits, accessories and optional;
- force majeure.

The manufacturer furthermore declines any and every responsibility for the failure to observe the contents of this manual.

2 Safety and prevention

2.1 Introduction

The burners have been designed and built in compliance with current regulations and directives, applying the known technical rules of safety and envisaging all the potential danger situations.

It is necessary, however, to bear in mind that the imprudent and clumsy use of the equipment may lead to situations of death risk for the user or third parties, as well as the damaging of the burner or other items. Inattention, thoughtlessness and excessive confidence often cause accidents; the same applies to tiredness and sleepiness.

It is a good idea to remember the following:

- The burner must only be used as expressly described. Any other use should be considered improper and therefore dangerous.

In particular:

it can be applied to boilers operating with water, steam, diathermic oil, and to other users expressly named by the manufacturer;

the type and pressure of the fuel, the voltage and frequency of the electrical power supply, the minimum and maximum deliveries for which the burner has been regulated, the pressurisation of the combustion chamber, the dimensions of the combustion chamber and the room temperature must all be within the values indicated in the instruction manual.

- Modification of the burner to alter its performance and destinations is not allowed.
- The burner must be used in exemplary technical safety conditions. Any disturbances that could compromise safety must be quickly eliminated.
- Opening or tampering with the burner components is not allowed, apart from the parts requiring maintenance.
- Only those parts envisaged by the manufacturer can be replaced.



The manufacturer guarantees safety and proper functioning only if all burner components are intact and positioned correctly.

2.2 Personnel training

The user is the person, body or company that has acquired the machine and intends to use it for the specific purpose. He is responsible for the machine and for the training of the people working around it.

The user:

- undertakes to entrust the machine exclusively to suitably trained and qualified personnel;
- undertakes to inform his personnel in a suitable way about the application and observance of the safety instructions. With that aim, he undertakes to ensure that everyone knows the use and safety instructions for his own duties;
- Personnel must observe all the danger and caution indications shown on the machine.
- Personnel must not carry out, on their own initiative, operations or interventions that are not within their province.
- Personnel must inform their superiors of every problem or dangerous situation that may arise.
- The assembly of parts of other makes, or any modifications, can alter the characteristics of the machine and hence compromise operating safety. The manufacturer therefore declines any and every responsibility for any damage that may be caused by the use of non-original parts.

In addition:



- the user must take all the measures necessary to prevent unauthorised people gaining access to the machine
- the user must inform the manufacturer if faults or malfunctioning of the accident prevention systems are noticed, along with any presumed danger situation
- personnel must always use the personal protective equipment envisaged by legislation and follow the indications given in this manual

3 Technical description of the burner

3.1 Burner designation

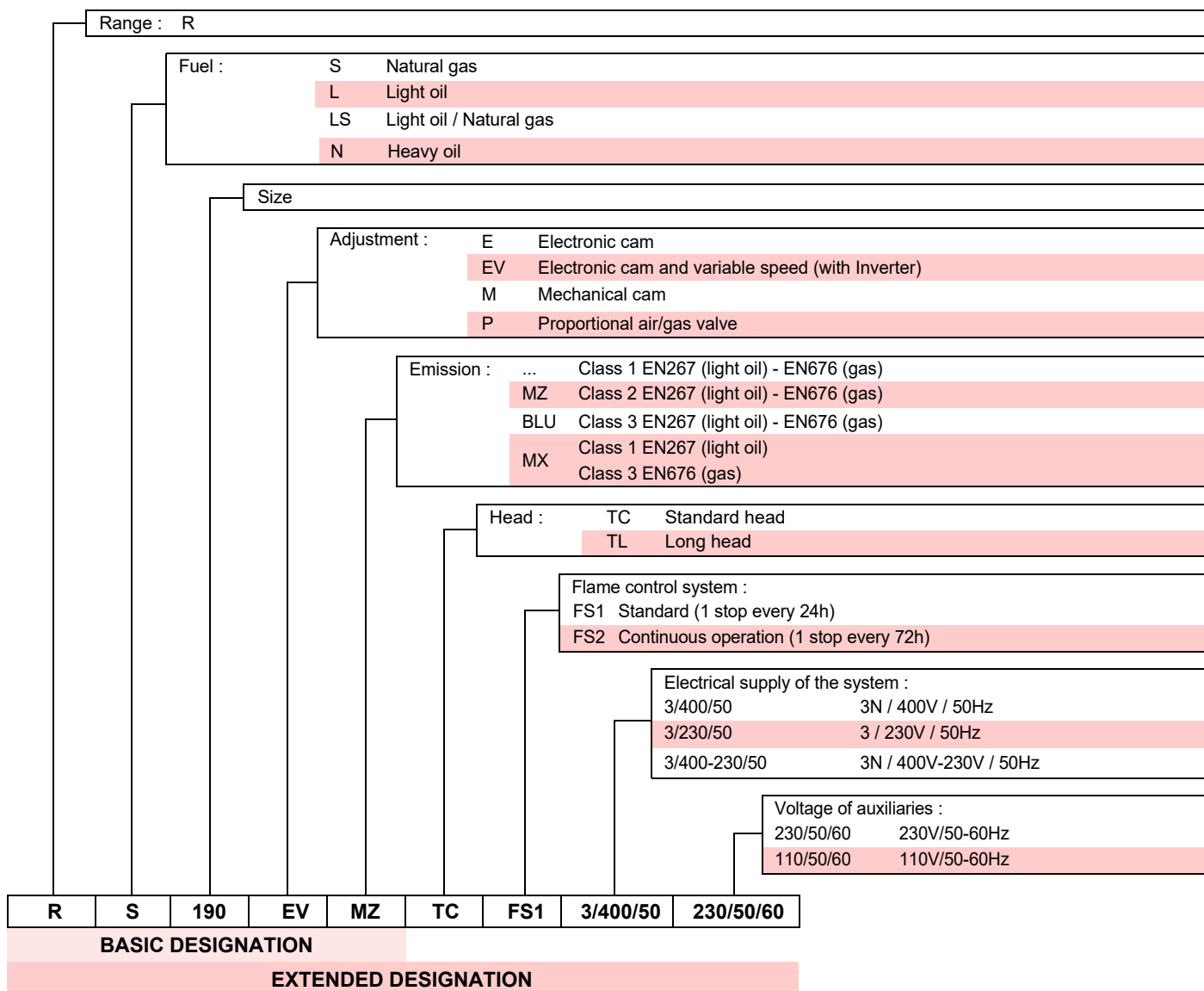

3.2 Models available

Designation	Voltage	Code
RS 190/EV MZ TC	3 ~ 400 / 50Hz	20142732

Tab. A

3.3 Burner categories - Countries of destination

Gas category	Country of destination
I12H3B/P	AT - BG - CH - CZ - DK - EE - FI - GR - HU - IS - IT - LT - NO - RO - SE - SK - SI - TR
I12H3P	ES- GB- IE- PT
I12E3	B/P LU- PL
I2E(R) I3P	BE
I12ELL3B/P	DE
I3B/P	CY- MT
I12EK3B/P	NL
I12Er3P	FR
I2H	LV

Tab. B

3.4 Technical data

Model			RS 190/EV MZ
Output ⁽¹⁾	maximum	kW Mcal/h	1279 - 2290 1100 - 1970
	minimum	kW Mcal/h	470 405
Fuel		Natural gas: G20 - G25	
Operation		Intermittent (min. 1 stop in 24 hours)	
Standard applications		Boilers: water, steam, diathermic oil	
Room temperature		°C	0 - 40
Combustion air temperature		°C max	60
Main electrical supply		3 ~ 400V +/-10% 50 Hz	
Control circuit power supply		1N ~ 230V 50 Hz	
Absorbed electrical power		kW max	5.3
Protection level		IP 44	
Noise levels ⁽²⁾	Sound pressure	dB(A)	83.1
	Sound power		94.1
Weight		89	
CE		CE-0476DP3335	

Tab. C

- (1) Reference conditions: Room temperature 20°C - Gas temperature 15°C - Barometric pressure 1013 mbar - Altitude 0 m above sea level.
- (2) Sound pressure measured in manufacturer's combustion laboratory, with burner operating on test boiler and at maximum rated output. The sound power is measured with the "Free Field" method, as per EN 15036, and according to an "Accuracy: Category 3" measuring accuracy, as set out in EN ISO 3746.

3.5 Maximum dimensions

The dimensions of the burner are shown in Fig. 1.

Bear in mind that inspection of the combustion head requires the burner to be opened and the rear part drawn back on the guides. The dimensions of the open burner are indicated by position I.

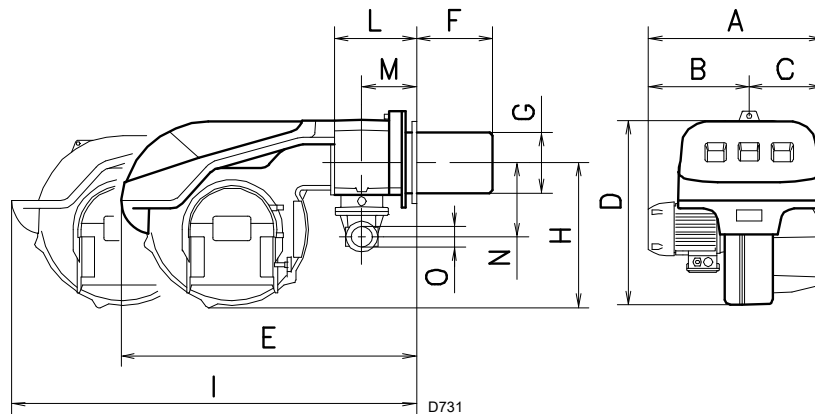

Fig. 1

mm	A	B	C	D	E	F ⁽¹⁾	G	H	I ⁽¹⁾	L	M	N	O
RS 190/EV	675	370	305	555	872	372	222	436	1328	230	150	223	2"

(1) Blast tube: short-long

3.6 Firing rate

The **maximum output** is chosen within area A of the diagram.
The **minimum output** must not be lower than the minimum limit of the diagram.



The firing rate was obtained considering an ambient temperature of 20°C and an atmospheric pressure of 1013 mbar (approx. 0 m above sea level), with the combustion head adjusted as shown at page 21.

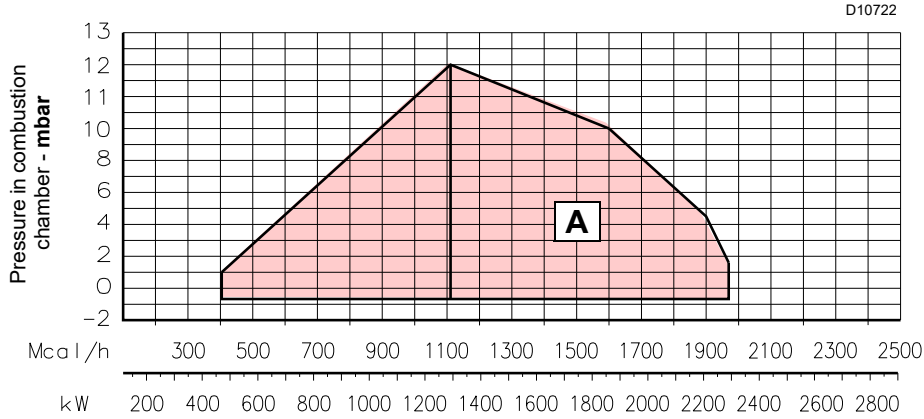

Fig. 2

3.7 Test boiler

The firing rates were obtained in special test boilers, according to EN 676 regulations.

Fig. 3 indicates the diameter and length of the test combustion chamber.

The coupling is ensured when the boiler is EC type-approved; for boilers or ovens with combustion chambers of very different dimensions compared to those shown in the diagram of Fig. 3, preliminary checks are recommended.

Example:

Output 756 kW (650 McaI/h) - diameter 60 cm, length 2 m.

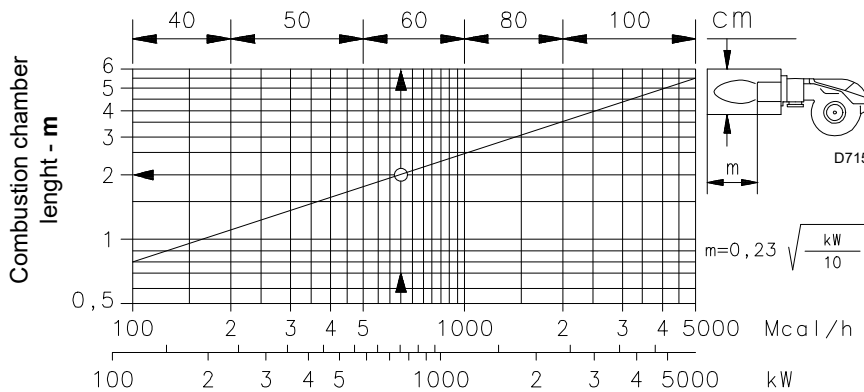

Fig. 3

3.8 Burner equipment

The burner is supplied complete with:

- Gas train flange
- Flange gasket
- 4 screws to fix the flange: M10 x 40
- Thermal insulation screen
- 4 Screws to fix the burner flange to the boiler: M16 x 40
- N° 2 Screws M4 x 7
- Extensions 32) for guides 20)
- Disc
- Small disc
- PVP kit for leak detection
- Instruction manual
- Spare parts list



It is recommended to tighten the screws of the gas flange with a tightening torque of **30 Nm ±10%**.

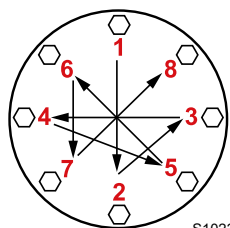

Tighten the nuts gradually (first to 30%, then to 60% up to 100%) according to the cross pattern shown in the figure.

3.9 Burner components

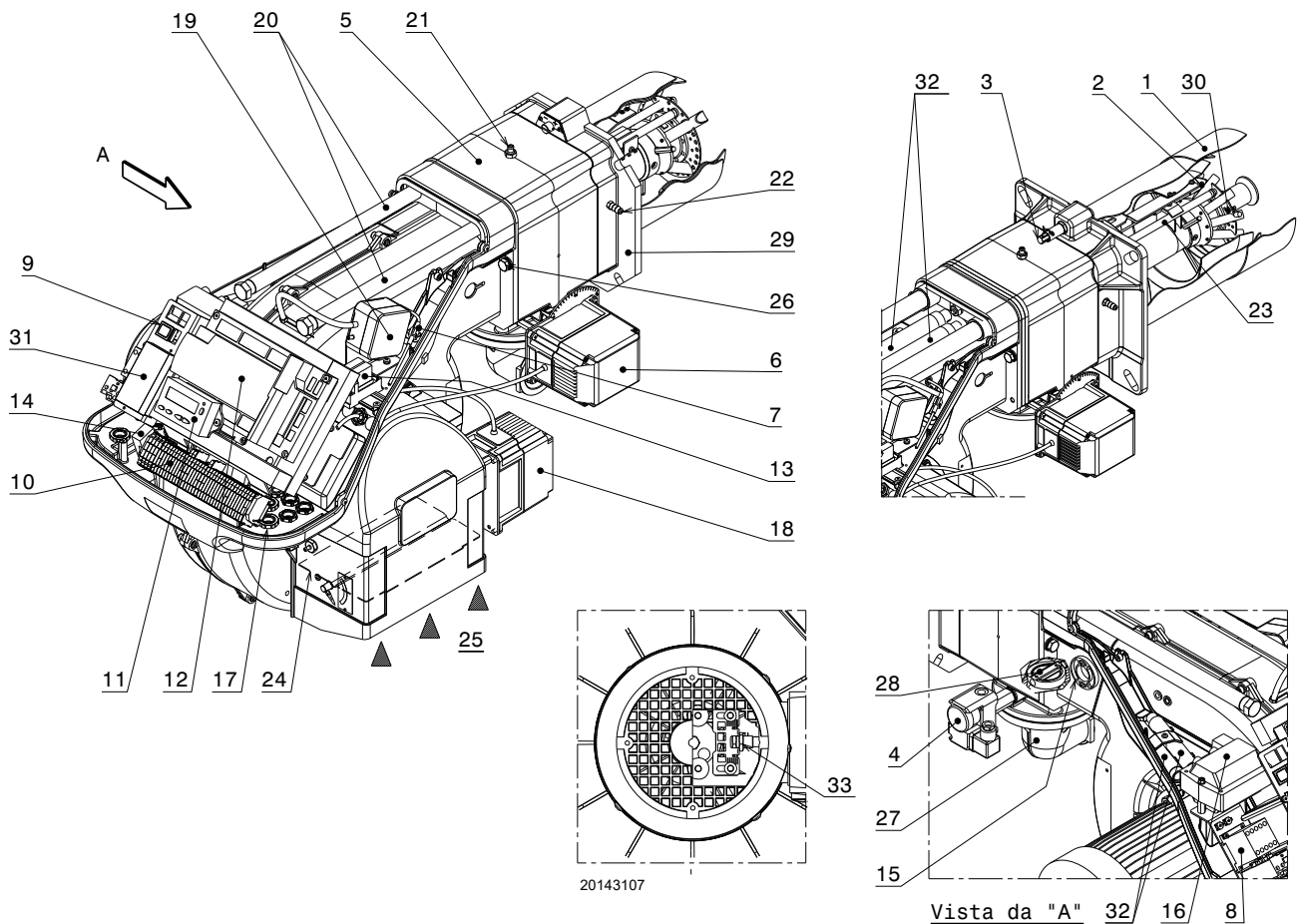

Fig. 4

- | | |
|--|--|
| 1 Combustion head | 27 Gas input pipe |
| 2 Ignition electrode | 28 Gas butterfly valve |
| 3 Screw for combustion head adjustment | 29 Boiler fixing flange |
| 4 Maximum gas pressure switch | 30 Flame stability disc |
| 5 Pipe coupling | 31 Bracket for application of output regulator RWF50 |
| 6 Gas servomotor | 32 Extensions for guides 20) |
| 7 Plug-socket on ionisation probe cable | 33 Revolution sensor |
| 8 Motor contact maker and thermal relay with reset button | |
| 9 Operation on/off switch | |
| 10 Terminal board for electrical wiring | |
| 11 Operator Panel with LCD display | |
| 12 Flame control for checking flame and air/fuel ratio | |
| 13 Clean contacts relay | |
| 14 Filter to protect against radio disturbance | |
| 15 Flame inspection window | |
| 16 Ignition transformer | |
| 17 Cable grommets for electrical wiring (to be carried out by the installer) | |
| 18 Air servomotor | |
| 19 Air pressure switch (differential type) | |
| 20 Guides for opening the burner and inspecting the combustion head | |
| 21 Gas pressure test point and head fixing screw | |
| 22 Air pressure socket | |
| 23 Flame sensor probe | |
| 24 Air damper | |
| 25 Fan air inlet | |
| 26 Screws to secure fan to pipe coupling | |

3.10 Flame control (REC 37.400A2)

Important notes



To avoid accidents, material or environmental damage, observe the following instructions!

The flame control is a safety device! Avoid opening or modifying it, or forcing its operation. Riello S.p.A. cannot assume any responsibility for damage resulting from unauthorised interventions!



Risk of explosion!

An incorrect configuration can provoke fuel overcharging, with the consequential risk of explosion! Operators must be aware that incorrect settings made on the display and operating unit and incorrect settings of the fuel and / or air actuator positions can lead to dangerous burner operating conditions.

- All interventions (assembly and installation operations, assistance, etc.) must be carried out by qualified personnel.
- Before modifying the wiring in the flame control connection area, fully disconnect the system from the power supply (omnipolar separation). Check the system is not powered and cannot be accidentally reconnected. Failure to do this will lead to the risk of electrocution.
- Protection against electrocution from the flame control and all connected electric components is obtained with correct assembly.
- Before any intervention (assembly and installation operations, assistance, etc.), ensure the wiring is in order and that the parameters are correctly set, then make the safety checks.
- Falls and collisions can negatively affect the safety functions. In this case, the flame control must not be operated, even if it displays no evident damage.
- During the programming of the control curves of the air-fuel ratio, the technician should constantly observe the quality of the combustion process (for example, using a gas analyser) and, if the combustion values are too low or if there are dangerous conditions, take the appropriate action, for example by manually switching off the system.
- The plugs of the connection cables or other accessories can be removed or changed when the system is off.
- The connections to the actuators do not provide a safe separation of the mains voltage. Before connecting or changing the actuators, the system should be switched off.

To ensure the safety and reliability of the flame control, the following instructions must also be followed:

- avoid conditions that can favour the development of condensate and humidity. Otherwise, before switching on again, make sure that the entire flame control is perfectly dry!
- Static charges must be avoided since they can damage the flame control's electronic components when touched.

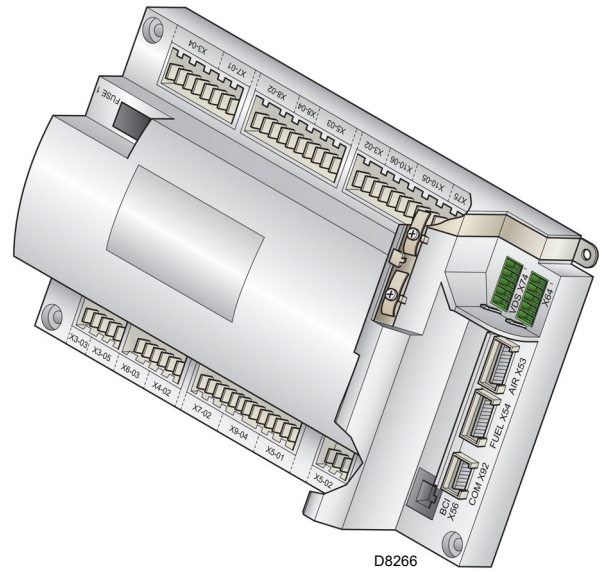

Electrical connection of flame detector

It is important for signal transmission to be almost totally free of any disturbances or loss:

- always separate the detector cables from the other cables:
 - line capacitance reduces the magnitude of the flame signal.
 - Use a separate cable.
- Respect the allowed cable lengths.
- The ionisation probe is not protected against the risk of elec-

trocutation; it must be protected against any accidental contact.

- The grounding of the burner must be in compliance with the rules in force; the grounding of the boiler alone is not enough.
- Position the ignition electrode and the ionisation probe so that the ignition spark cannot form an arc on the probe (risk of electric overcharge).

Technical data

Flame control	Mains voltage	AC 230 V -15 % / +10 %
	Mains frequency	50 / 60 Hz ±6 %
	Power absorption	< 30 W (normal)
	Safety class	I, with components in compliance with II and III, according to DIN EN 60730-1
Load on 'input' terminals	F1 unit fuse (internal)	6,3 AT
	Main fuse of perm. network (external)	Max. 16 AT
	Undervoltage	
	– Safety switch-off from operating position to mains voltage	< AC 186 V
	– Restart when mains voltage picks up	> AC 195 V
	Input currents and input voltages	
	– UeMax	UN +10%
	– UeMin	UN -15%
	– IeMax	1.5 mA peak
	– IeMin	0.7 mA peak
Voltage detection	– On	AC 180...253 V
	– Off	< AC 80 V
Load on 'output' terminals	Total load on the contacts	
	– Mains voltage	AC 230 V, 50 / 60 Hz
	– Total unit input current (safety circuit)	Max. 5 A
	– Fan motor contactor	
	– Ignition transformer	
	– Valve	
	Single contact loading	
	Fan motor contactor	
	– Rated voltage	AC 230 V, 50 / 60 Hz
	– Nominal current	2A
	– Power factor	cosφ > 0.4
	Alarm output	
	– Rated voltage	AC 230 V, 50 / 60 Hz
	– Nominal current	1A
	– Power factor	cosφ > 0.4
	Ignition transformer	
	– Rated voltage	AC 230 V, 50 / 60 Hz
– Nominal current	2A	
– Power factor	cosφ > 0.2	
Fuel valve		
– Rated voltage	AC 230 V, 50 / 60 Hz	
– Nominal current	2A	
– Power factor	cosφ > 0.4	
Display operation		
– Rated voltage	AC 230 V, 50 / 60 Hz	
– Nominal current	0,5A	
– Power factor	cosφ > 0.4	

Cable lengths	- Main line AC 230 V	Max. 100 m (100 pF / m)
	- Display, BCI	For installation under the casing of the burner or in the control panel max. 3 m (100 pF / m)
	- Load control (LR) X5-03	Max. 20 m (100 pF/m)
	- External reset button	Max 20 m (100 pF/m)
	- Safety valve (SV)	Max 20 m (100 pF/m)
	- Load output	Max. 10 m (100 pF/m)
	- Fuel valve	Max. 3 m (100 pF/m)
	- Pilot valve	Max. 3 m (100 pF/m)
	- Ignition transformer	Max. 3 m (100 pF/m)
	- Other lines	Max. 3 m (100 pF/m)
Cross-sections of the power supply lines	They should be sized for rated currents as per the primary external fuse and the fuse of the internal unit.	
	- Min. cross-section	(max. 6.3 AT) 0.75 mm ²
	- Fuses used inside the flame control F1	6.3 AT DIN EN 60127 2 / 5
Environmental conditions	Storage	DIN EN 60721-3-1
	- Climatic conditions	Class 1K3
	- Mechanical conditions	Class 1M2
	- Temperature range	-20 ... +60 °C
	- Humidity	< 95% RH
	Transport	DIN EN 60721-3-2
	- Climatic conditions	Class 2K2
	- Mechanical conditions	Class 2M2
	- Temperature range	-30 ... +60 °C
	- Humidity	< 95% RH
	Operation	DIN EN 60721-3-3
	- Climatic conditions	Class 3K3
- Mechanical conditions	Class 3M3	
- Temperature range	-20 ... +60 °C	
- Humidity	< 95% RH	

Tab. D



Condensation, formation of ice and the entrance of water are not permitted!

3.11 Operation sequence of the burner

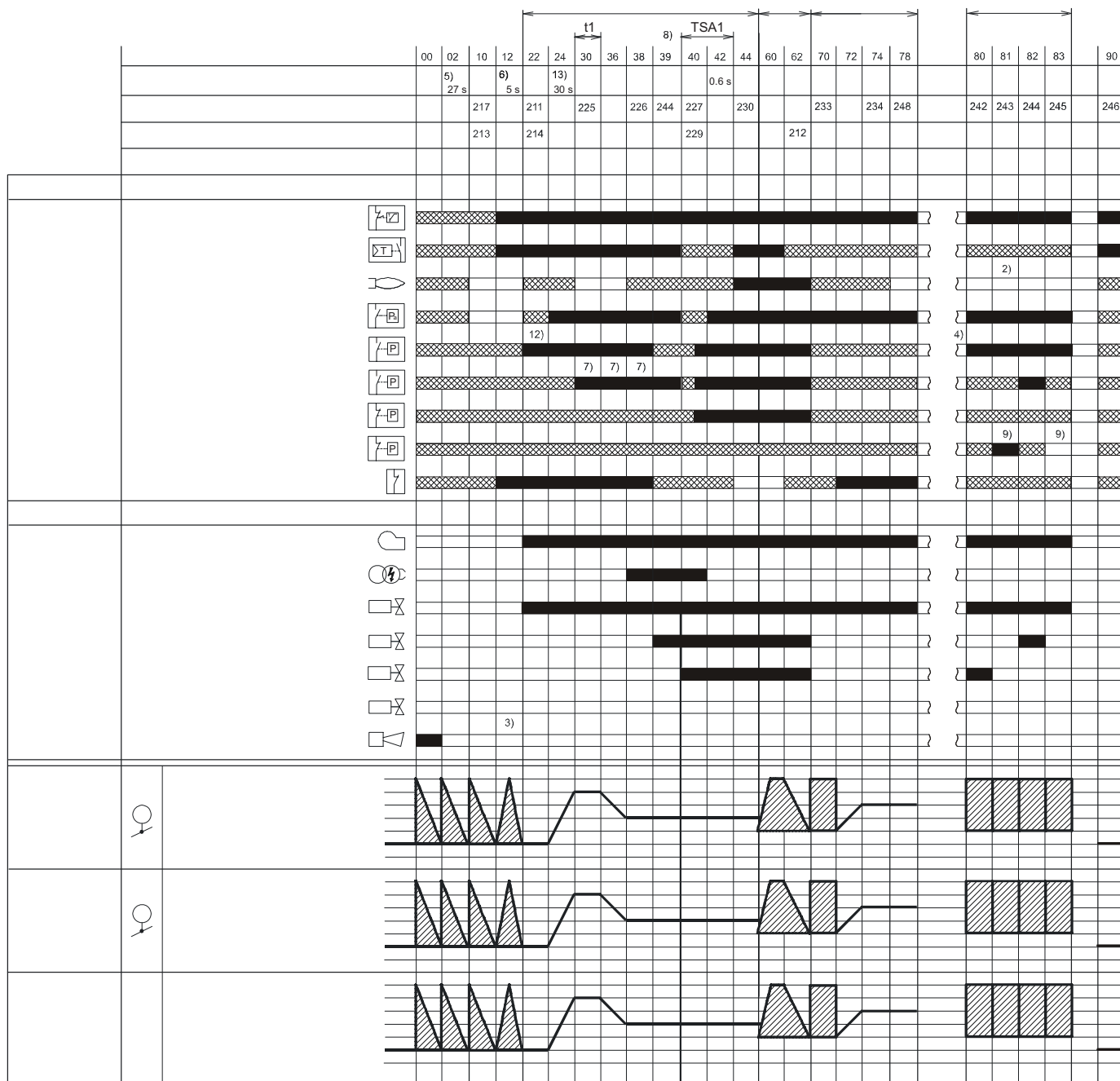

S8887

Fig. 6

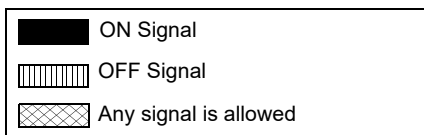

3.11.1 List of phases

Phase	Description
Ph00	Lockout phase
Ph02	Safety phase
Ph10	Closing paused
Ph12	Standby
Ph22	Fan motor (MV) = ON Safety valve (VS) = ON
Ph24	The burner moves to the pre-purging position
Ph30	Pre-purging time
Ph36	The burner moves to the ignition position
Ph38	Ignition phase (TA) = ON
Ph39	Min. gas pressure switch test (PGmin.)
Ph40	Fuel valve (V) = ON
Ph42	Ignition (TA) = OFF

Phase	Description
Ph44	t44 = interval time 1
Ph60	Operation
Ph62	The burner moves to the switching off position
Ph70	t13 = post-combustion time
Ph72	The burner moves to the post-purging position
Ph74	t8 = post-purging time
Ph78	t3 = post-purging time
Ph80	Emptying time (valve leak detection)
Ph81	Atmospheric test time (valve leak detection)
Ph82	Filling time (valve leak detection)
Ph83	Pressure test time (valve leak detection)
Ph90	Standby time due to lack of gas

3.12 Operator panel operation

The flame control REC 37.400A2 is directly connected to the operator panel (Fig. 7).

The buttons allow you to programme the operation and diagnostics menus.

The burner management system is visualised on the LCD display (Fig. 8). To simplify the diagnostics, the display shows the operating status, type of problem, and when the problem arose.



WARNING

- Observe the procedures and adjustments shown below.
- All interventions (assembly and installation operations, assistance, etc.) must be carried out by qualified personnel.
- If the display and operator panel are dirty, clean them with a dry cloth.
- Protect the panel from excessive temperatures and liquids.

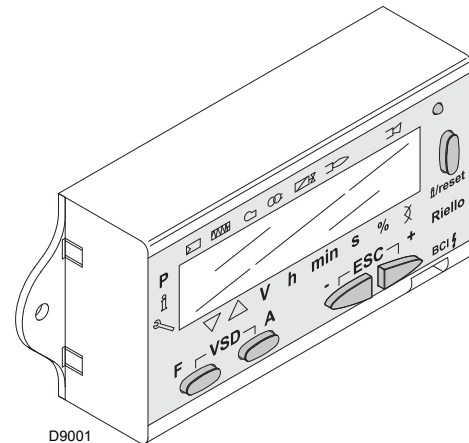

Fig. 7

3.12.1 Symbols description on the display

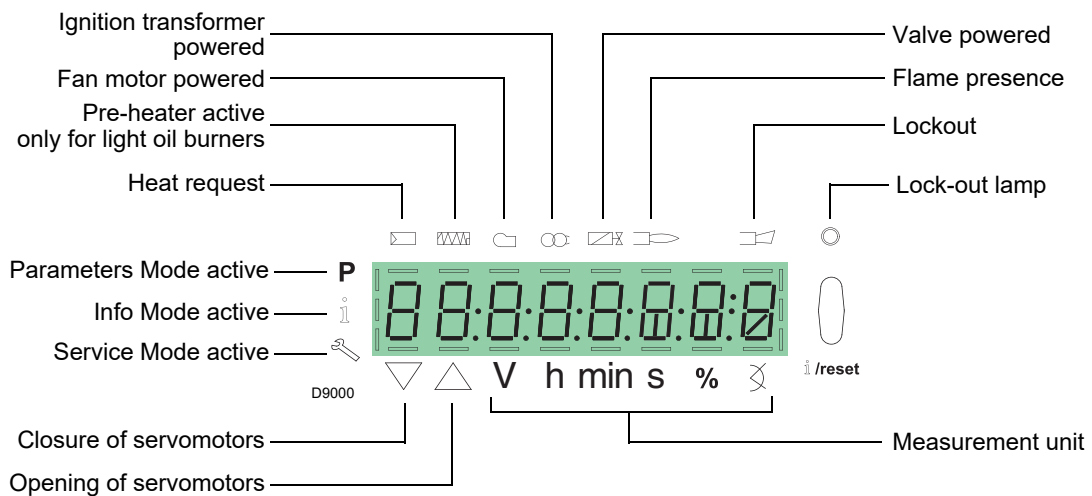







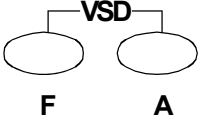







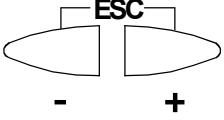



Fig. 8

The display brightness can be regulated from 0 ... 100% with parameter 126.

3.12.2 Buttons description

Button	Button	Function
	Button F	To regulate the fuel servomotor (keep pressed  and adjust the value by pressing  or )
	Button A	To regulate the servomotor air (keep pressed  and adjust the value by pressing  or )
	Button A and F VSD Function	To modify the parameter for setting the P mode (simultaneously press  and  plus  or )
 i/reset	Button Info and Enter	<ul style="list-style-type: none"> • Enter in Parameters Mode • Reset in the event of a lockout • Access to a lower level of the menu • To navigate in Service or Info Mode and allows: <ul style="list-style-type: none"> – the selection of the parameter (flashing symbol) (press for <1 s) – access to a lower level of the menu (press from 1...3 s) – access to a higher level of the menu (press from 3...8 s) – access to another Mode (press for > 8 s)
	Button -	Reduction of the value <ul style="list-style-type: none"> – Access to a lower point of the modulation curve – Scrolling of the parameter list
	Button +	Increase of the value <ul style="list-style-type: none"> – Access to a higher point of the modulation curve – Scrolling of the parameter list
	Buttons - and +	Quit function (ESC) (press  and  simultaneously) <ul style="list-style-type: none"> – Does not confirm the value – Access to a higher level of the menu

Tab. E

3.13 Servomotors (SQM33....)

Important notes



To avoid accidents, material or environmental damage, observe the following instructions!

Avoid opening, modifying or forcing the servomotor.

- All interventions (assembly and installation operations, assistance, etc.) must be carried out by qualified personnel.
- Before modifying the wiring in the servomotor connection area, fully disconnect the burner control device from the power supply (omnipolar separation).
- To avoid the risk of electrocution, protect the connection terminals in a suitable manner and correctly fix the cover.
- Check the wiring is in order.
- Falls and collisions can negatively affect the safety functions. In this case, the unit must not be operated, even if it displays no evident damage.

Assembly notes

- Check the relevant national safety standards are respected.
- The connection between the actuator command shaft and the control element must be rigid, without any mechanical play.
- To avoid an excessive load on the bearings due to rigid hubs, the use of compensation clutches without any mechanical play is recommended (e.g. metal bellows-type clutches).

Installation notes

- Arrange the H.V. ignition cables separately, as far as possible from the flame control and the other cables.
- To avoid the risk of electrocution, make sure that the 230V AC section of the servomotor is fully separated from the functional low-voltage section.
- The static torque is reduced when the electrical supply of the actuator is switched off.
- The housing cover may only be removed for short periods of time for wiring or when making the addressing. In similar cases, make sure that dust or dirt does not penetrate inside the actuator.
- The servomotor comprises a PCB with ESD-sensitive components.
- The top side of the board carries a cover which affords protection against direct contact. This protective cover must not be removed! The underside side of the board must not be touched.



During the maintenance or replacement of the servomotors, be careful not to invert the connectors.

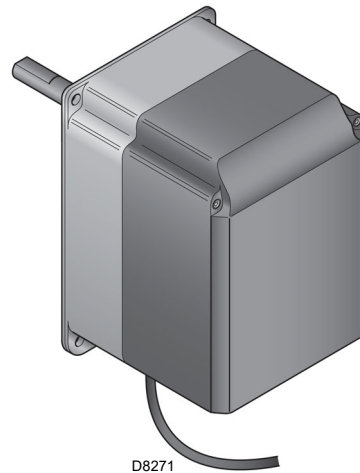

Fig. 9

Technical data

Model	SQM33.4...	SQM33.5...
Operating voltage	AC / DC 24 V ± 20 %	
Safety class	2 according to EN 60 730	
Power consumption	Max. 7.5 W	Max. 10 W
Degree of protection	IP54 according to EN 60 529-1	
Cable connection	RAST2, connectors	
Rotation direction	- Anticlockwise (standard) - Clockwise (inverted rotation)	
Nominal torque (max)	1.2 Nm	3 Nm
Holding torque (max)	1.2 Nm	3 Nm
Running time for 90°	5 s.	
Weight	1.4 kg about	
Environmental conditions:		
Operation	DIN EN 60 721-3-3	
Climatic conditions	Class 3K5	
Mechanical conditions	Class 3M4	
Temperature range	-20...+60 °C	
Humidity	< 95% RH	

Tab. F



Condensation, formation of ice and the entrance of water are not permitted!

4 Installation

4.1 Notes on safety for the installation

After carefully cleaning all around the area where the burner will be installed, and arranging the correct lighting of the environment, proceed with the installation operations.



All the installation, maintenance and disassembly operations must be carried out with the electricity supply disconnected.



The installation of the burner must be carried out by qualified personnel, as indicated in this manual and in compliance with the standards and regulations of the laws in force.



Combustion air inside the boiler must be free from hazardous mixes (e.g.: chloride, fluoride, halogen); if present, it is highly recommended to carry out cleaning and maintenance more frequently.

4.2 Handling

The packaging of the burner includes a wooden platform, so it is possible to move the burner (still packaged) with a transpallet truck or fork lift truck.



The handling operations for the burner can be highly dangerous if not carried out with the greatest attention: keep any unauthorised people at a distance; check the integrity and suitability of the available means of handling.

Check also that the area in which you are working is empty and that there is an adequate escape area (i.e. a free, safe area to which you can quickly move if the burner should fall).

When handling, keep the load at not more than 20-25 cm from the ground.



After positioning the burner near the installation point, correctly dispose of all residual packaging, separating the various types of material.



Before proceeding with the installation operations, carefully clean all around the area where the burner will be installed.

4.3 Preliminary checks

Checking the consignment



After removing all the packaging, check the integrity of the contents. In the event of doubt, do not use the burner; contact the supplier.



The packaging elements (wooden cage or cardboard box, nails, clips, plastic bags, etc.) must not be abandoned as they are potential sources of danger and pollution; they should be collected and disposed of in the appropriate places.

		A		B	
		D		C	
		E		F	
GAS-KAASU	<input checked="" type="checkbox"/>	FAM.2		G	
GAZ-AEPIO	<input type="checkbox"/>	FAM.3		H	
		G		H	
I	I	I	I	I	I
				CE	

20187902

Fig. 10

Checking the characteristics of the burner

Check the identification label of the burner (Fig. 10), showing:

- A the burner model
- B the burner type
- C the cryptographic year of manufacture
- D the serial number
- E the data for electrical supply and the protection level
- F the electrical power consumption
- G the types of gas used and the relative supply pressures
- H the data of the burner's minimum and maximum output possibilities (see Firing rate)
- Warning.** The burner output must be within the boiler's firing rate
- I the category of the appliance/countries of destination



A burner label, or any other component, that has been tampered with, removed or is missing, prevents the definite identification of the burner and makes any installation or maintenance work difficult.

4.4 Operating position



- The burner is designed to operate only in positions 1, 2, 3 and 4 (Fig. 11).
- Installation 1 is preferable, as it is the only one that allows the maintenance operations as described in this manual.
- Installations 2, 3 and 4 permit operation but make maintenance and inspection of the combustion head more difficult.



- Any other position could compromise the correct operation of the appliance.
- Installation 5 is prohibited for safety reasons.

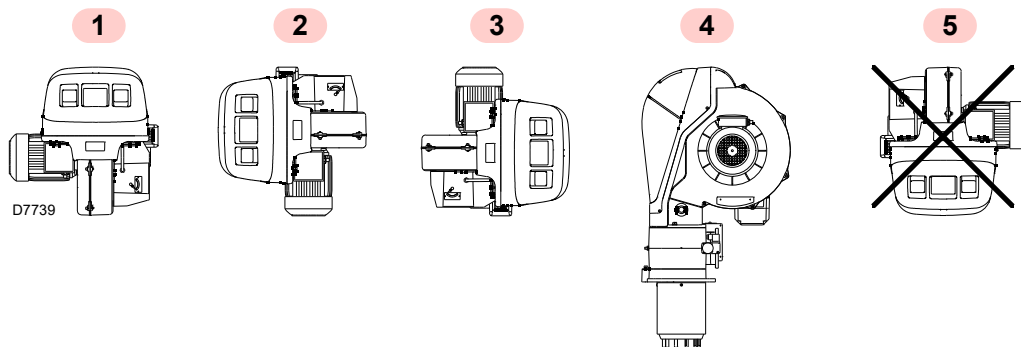

Fig. 11

4.5 Preparing the boiler

4.5.1 Boring the boiler plate

Drill holes in the plate shutting off the combustion chamber, as illustrated in Fig. 12.

The position of the threaded holes can be marked using the thermal insulation screen supplied with the burner.

4.5.2 Blast tube length

The length of the blast tube must be selected according to the indications provided by the manufacturer of the boiler, and in any case it must be greater than the thickness of the boiler door complete with its refractory.

The lengths L available are:

Blast tube	Short (mm)	Long (mm)
RS 190/EV MZ	372	522

Tab. G

For boilers with front flue passes 13)(Fig. 15 at page 20), a protection in refractory material 11) must be inserted between the boiler refractory 12) and the blast tube 10).

This protection must not compromise the extraction of the blast tube.

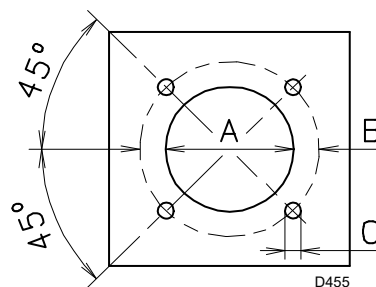

Fig. 12

mm	A	B	C
RS 190/EV MZ	230	325-368	M 16

Tab. H

4.6 Positioning probe - electrode



WARNING

Before fixing the burner to the boiler, check from the opening of the blast tube that the probe and the electrode are correctly positioned, as in Fig. 14.

If, in the previous check, the position of the probe or electrode was not correct, is necessary:

- remove the screw 1)(Fig. 13);
- extract the inner part 2)(Fig. 13) of the head, and adjust them.



WARNING

Do not rotate the probe: leave it as in Fig. 14.
If it is located too close to the ignition electrode, the flame control amplifier may be damaged.



WARNING

Observe the dimensions shown in Fig. 14.

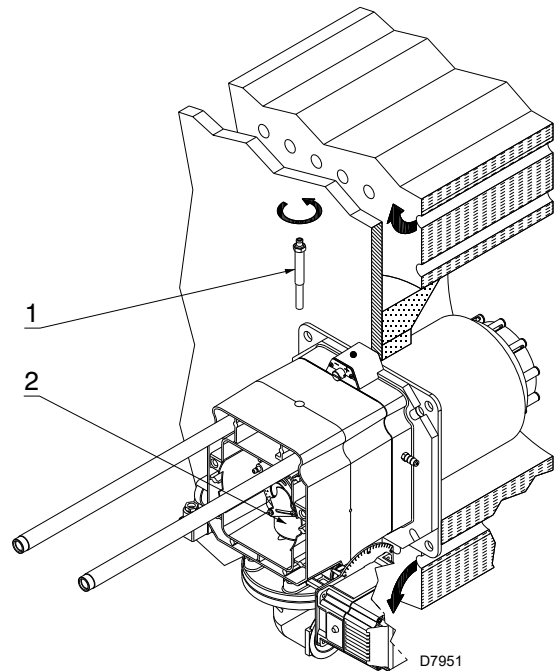

Fig. 13

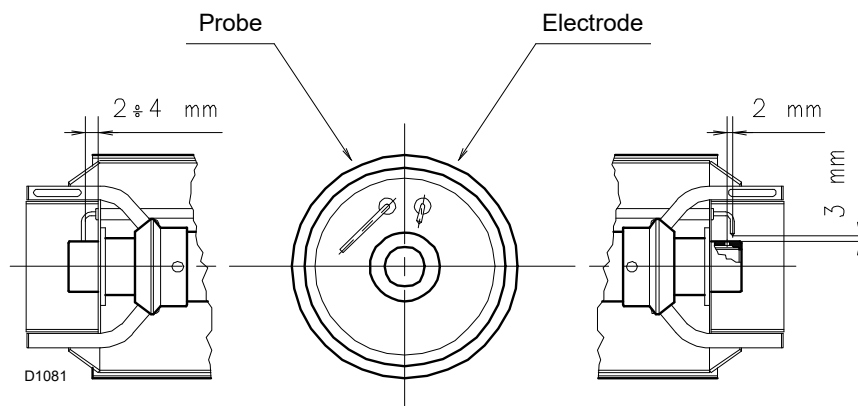

Fig. 14

4.7 Securing the burner to the boiler



Provide an adequate lifting system of the burner.

Separate the combustion head from the rest of the burner, as in Fig. 15; proceed as follows:

- loosen the 4 screws 3) and remove the hood 1);
- remove the screws 2) from the two guides 5);
- disconnect the plug 14), unscrew the grommet 15);
- disconnect the socket from the maximum gas pressure switch;
- remove the two screws 4);

- pull back the burner on the guides 5) by about 100 mm;
- disconnect the probe and electrode leads, then unthread the burner completely from the guides.

Once this operation has been carried out:

- fix the flange 9) to the boiler plate, interposing the supplied insulating gasket 8).
- Use the 4 screws supplied, with a tightening torque of 35 ± 40 Nm, after protecting their thread with anti-seize products.



The seal between burner and boiler must be air-tight; after the start-up, check there is no leakage of flue gases into the external environment.

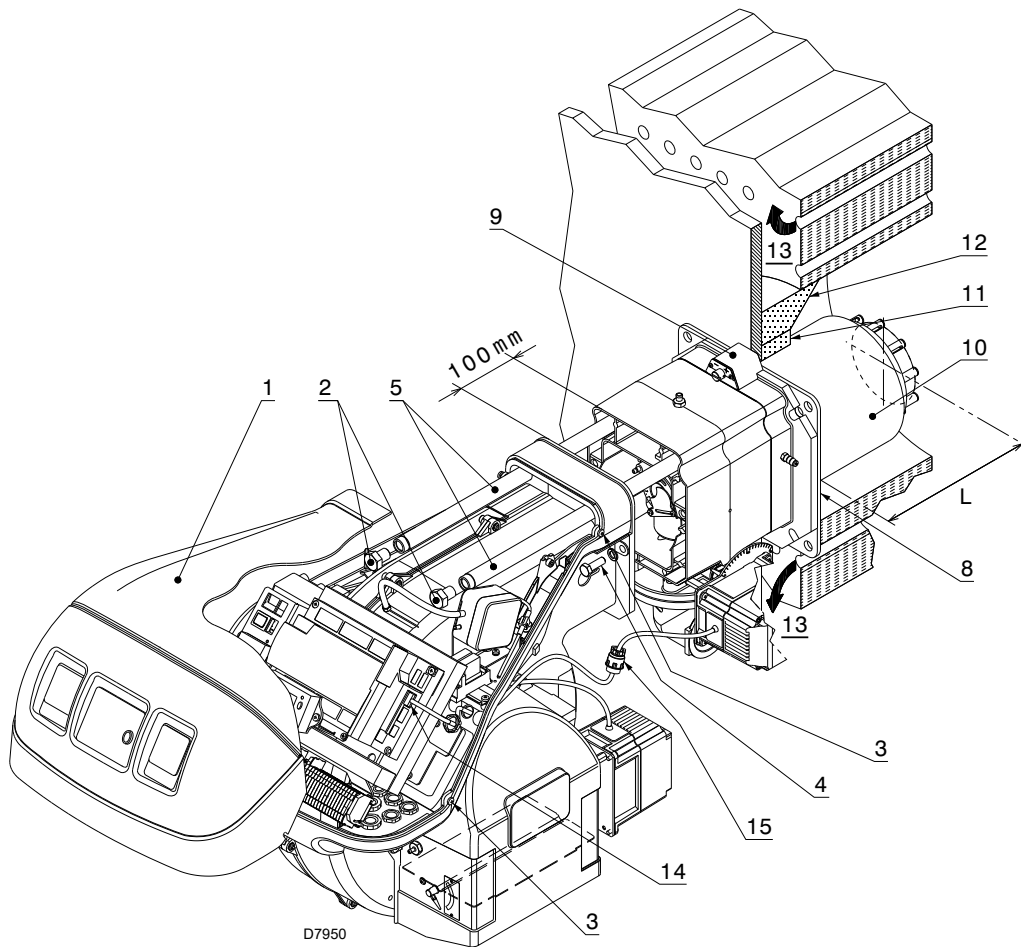

Fig. 15

4.8 Combustion head adjustment

At this point of the installation, the combustion head is fixed to the boiler as shown in Fig. 15 at page 20. It is therefore especially easy to adjust, and this adjustment depends only on the maximum output of the burner.

Two adjustments of the head are foreseen:

- the air adjustment;
- the gas adjustment.

In the diagram of Fig. 18, find the notch at which to adjust both air and central gas/air.

Air adjustment

Rotate the screw 2) until the notch you have found corresponds with the front surface 1) of the flange, Fig. 16.



Important

To facilitate adjustment, loosen the screw 3)(Fig. 16), adjust and then lock.

Gas adjustment

When the burner is installed for maximum burner output ≤ 1300 Mcal/h (approx. 1500 kW) fit the discs 1)-2)(Fig. 17), supplied as part of the standard equipment, removing the internal tube 3)(Fig. 17). If the mains gas pressure is low, the head can be left in the standard set-up, limiting the modulation minimum to 450 Mcal/h (approx. 520 kW).

Example

Burner output = 1400 kW.

According to diagram Fig. 18 the gas and air adjustments for this output are carried out on notch 5.

NOTE:

The diagram indicates the optimum adjustment for a type of boiler according to Fig. 3 at page 8.

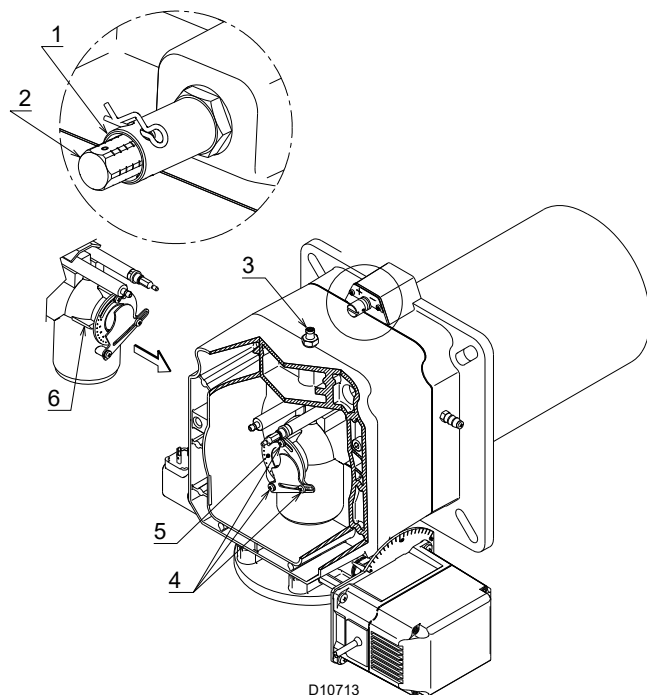

Fig. 16

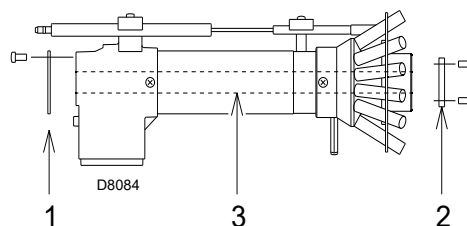

Fig. 17

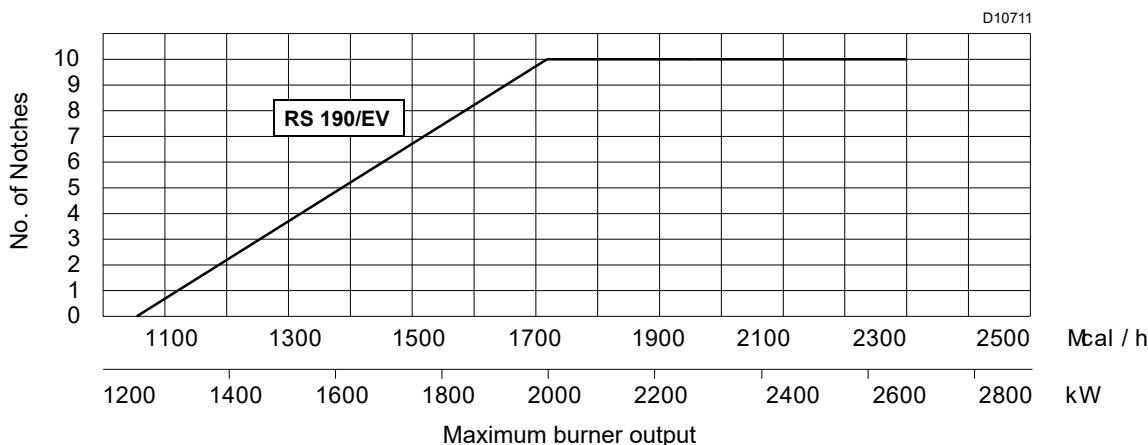

Fig. 18

NOTE:

The adjustments indicated can be modified during the initial start-up.

4.9 Burner closing

Once the combustion head adjustment is completed:

- reassemble the burner on the guides 3)(Fig. 19) at about 100 mm from the pipe coupling 4) - burner in the position shown in Fig. 15 at page 20;
- insert the probe and electrode cables, then slide the burner as far as the pipe coupling - burner in the position shown in Fig. 19;
- connect the plug of the servomotor 14)(Fig. 15 at page 20) and tighten the cable grommet 15);

- connect the socket of the maximum gas pressure switch;
- refit the screws 2)(Fig. 19) on the guides 3);
- fix the burner to the pipe coupling with the screws 1).



When fitting the burner on the two guides, it is advisable to gently draw out the high voltage cable and flame detection probe cable until they are slightly taut.

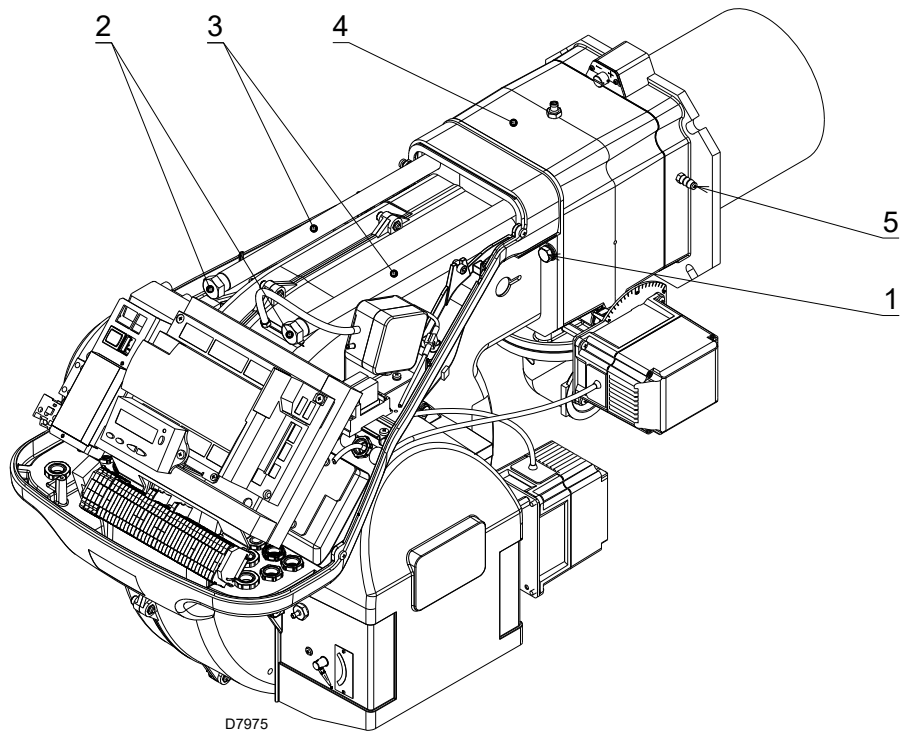

Fig. 19

4.10 Gas feeding



Explosion danger due to fuel leaks in the presence of a flammable source.
 Precautions: avoid knocking, attrition, sparks and heat.
 Make sure that the fuel interception tap is closed before performing any operation on the burner.



The fuel supply line must be installed by qualified personnel, in compliance with current standards and laws.

4.10.1 Gas feeding line (Example) - Please refer to the gas train documentation for more information

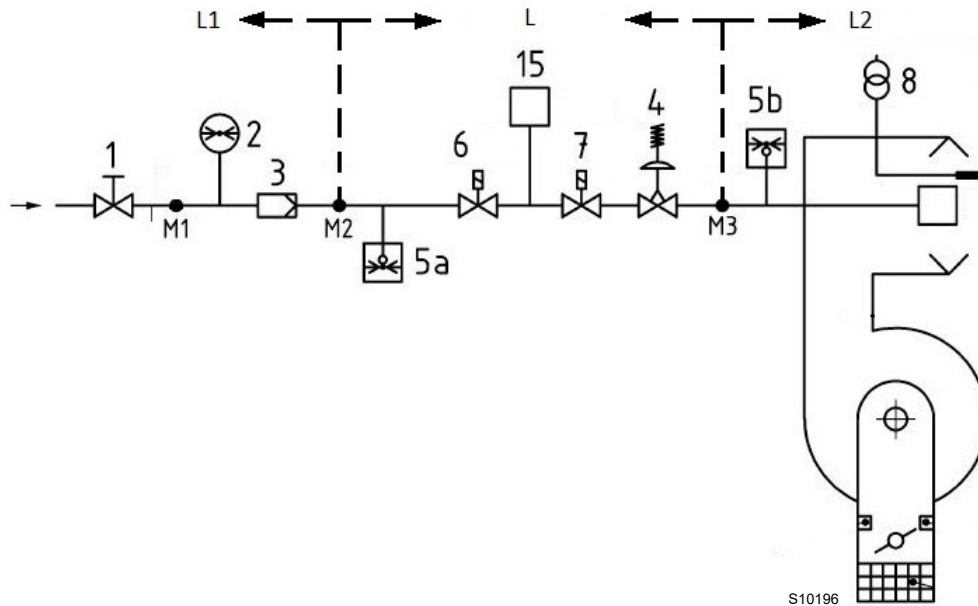

Fig. 20

Key (Fig. 20)

- 1 Manually operated shut-off valve
- 2 Pressure gauge
- 3 Filter
- 4 Governor
- 5a Low pressure protection device
- 5b Maximum gas pressure switch
- 6 1st safety shut-off device
- 7 2nd safety shut-off device
- 8 Ignition device
- 15 Valve leak detection control system
- L Gas train (supplied separately)
- L1 Responsibility of the installer
- L2 Burner
- M1 Pressure test point
- M2 Pressure test point
- M3 Pressure test point

4.10.2 Gas train

Type-approved in accordance with EN 676 and supplied separately from the burner.

4.10.3 Gas train installation



Disconnect the electrical power using the main system switch.



Check that there are no gas leaks.



Beware of train movements: danger of crushing of limbs.



Make sure that the gas train is properly installed by checking for any fuel leaks.



The operator must use appropriate tools for installation.

The gas train can enter the burner from the right or left side, depending on which is the most convenient, see Fig. 21.

The gas train must be connected to the gas attachment 1)(Fig. 21), with the flange 2), the gasket 3) and the screws 4) supplied with the burner.



The gas solenoids must be as close as possible to the burner, to ensure that the gas reaches the combustion head within the safety time of 3s.

Ensure that the maximum pressure to the burner is within the calibration range of the pressure regulator.

See the accompanying instructions for the adjustment of the gas train.



The data of thermal output and combustion head gas pressure are related to full open (90°) gas butterfly valve.

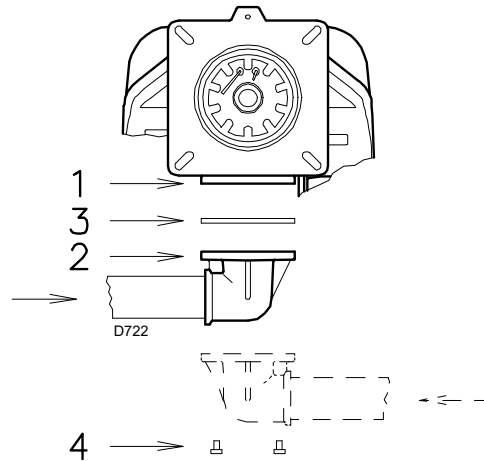

Fig. 21

4.10.4 Gas pressure

Tab. I indicates the pressure drop of the combustion head and the gas butterfly valve depending on the operating output of the burner.

kW	1 Δp (mbar)		2 Δp (mbar)	
	G 20	G 25	G 20	G 25
1280	9.6	14.3	1.3	2.0
1500	9.7	14.5	1.8	2.7
1800	9.9	14.8	2.7	4.0
2100	12.6	18.8	3.6	5.4
2290	14.9	22.2	4.3	6.4

Tab. I

The values shown in Tab. I refer to:

- Natural gas G 20 NCV 9.45 kWh/Sm³ (8.2 Mcal/Sm³)
- Natural gas G 25 NCV 8.13 kWh/Sm³ (7.0 Mcal/Sm³)

Column 1

Load loss at combustion head.

Gas pressure measured at the test point 1)(Fig. 22), with:

- combustion chamber at 0 mbar;
- burner working at maximum output;

Column 2

Pressure loss at gas butterfly valve 2)(Fig. 22) with maximum opening: 90°.

To know the approximate output at which the burner is operating at its maximum:

- Subtract the combustion chamber pressure from the gas pressure measured at test point 1)(Fig. 22).
- Find, in the Tab. I relating to the burner concerned, column 1, the pressure value closest to the result you want.
- Read the corresponding output on the left.

Example with natural gas G 20:

Maximum output operation	
Gas pressure at test point 1)(Fig. 22)	= 16.9 mbar
Pressure in combustion chamber	= 2.0 mbar
16.9 - 2.0	= 14.9 mbar

A maximum output of 2290 kW shown in Tab. I corresponds to 14.9 mbar pressure, column 1.

This value serves as a rough guide; the effective output must be measured at the gas meter.

To know the required gas pressure at test point 1)(Fig. 22), set the maximum output required from the burner operation, then:

- find the nearest output value in the Tab. I for the burner in question.
- Read, on the right (column 1) the socket pressure 1)(Fig. 22).
- Add this value to the estimated pressure in the combustion chamber.

Example with natural gas G 20:

Required burner maximum output operation: 2290 kW

Gas pressure at output of 2290 kW = 14.9 mbar

Pressure in combustion chamber = 2,0 mbar

14.9 + 2,0 = 16.9 mbar

pressure required at test point 1)(Fig. 22).

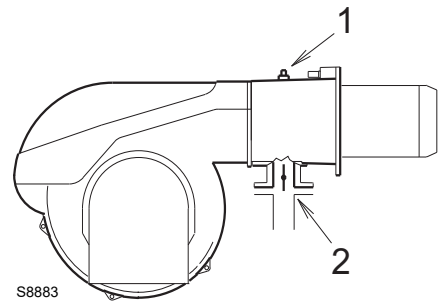

Fig. 22

4.11 Electrical wiring

Notes on safety for the electrical wiring



- The electrical wiring must be carried out with the electrical supply disconnected.
- Electrical wiring must be made in accordance with the regulations currently in force in the country of destination and by qualified personnel. Refer to the wiring diagrams.
- The manufacturer declines all responsibility for modifications or connections different from those shown in the wiring diagrams
- Check that the electrical supply of the burner corresponds to that shown on the identification label and in this manual.
- The burner has been type-approved for intermittent use. This means they should compulsorily be stopped at least once every 24 hours to enable the flame control to perform checks of its own start-up efficiency. Normally, burner stopping is guaranteed by the boiler's thermostat/pressure switch. If this is not the case, a time switch should be fitted in series to TL to stop the burner at least once every 24 hours. Refer to the wiring diagrams.
- The electrical safety of the device is obtained only when it is correctly connected to an efficient earthing system, made according to current standards. It is necessary to check this fundamental safety requirement. In the event of doubt, have the electrical system checked by qualified personnel. Do not use the gas tubes as an earthing system for electrical devices.
- The electrical system must be suitable for the maximum power absorption of the device, as indicated on the label and in the manual, checking in particular that the section of the cables is suitable for that level of power absorption.
- For the main power supply of the device from the electricity mains:
 - do not use adapters, multiple sockets or extensions;
 - use a multiple pole switch with at least a 3mm gap between the contacts (overvoltage category III), as envisaged by the present safety standards.
- Do not touch the device with wet or damp body parts and/or in bare feet.
- Do not pull the electric cables.

Before carrying out any maintenance, cleaning or checking operations:



Disconnect the electrical supply from the burner by means of the main system switch.



Close the fuel interception tap.



Avoid condensate, ice and water leaks from forming.

If the hood is still present, remove it and proceed with the electrical wiring according to the wiring diagrams.

Use flexible cables in compliance with the EN 60 335-1 standard.

4.11.1 Supply cables and external connections passage

All the cables to be connected to the burner are fed through the grommets. See Fig. 21.

The use of the cable grommets can take various forms. By way of example we indicate the following mode:

- 1 single-phase power supply
- 2 available
- 3 consent/safety
- 4 minimum gas pressure switch and leak detection
- 5 gas valves
- 6 signal cable input from the inverter

Cable grommets used in the factory:

- A rpm sensor
- B maximum gas pressure switch
- C gas servomotor
- D air servomotor

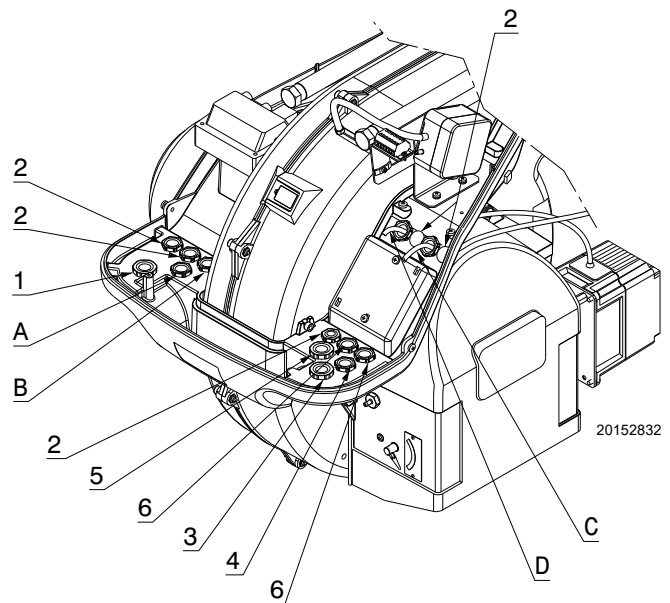

Fig. 23



After carrying out maintenance, cleaning or checking operations, reassemble the hood and all the safety and protection devices of the burner.

4.11.2 Motor cable shield



It is important to shield the motor cable 1) as indicated in Fig. 24.

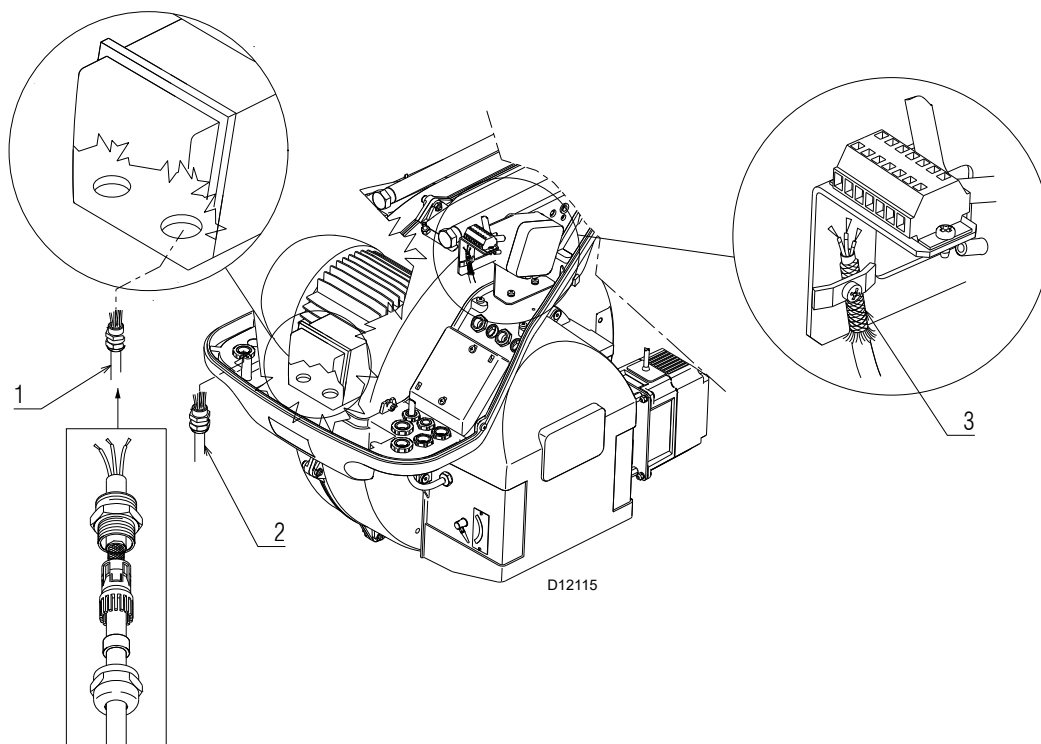

Fig. 24

Key (Fig. 24)

- 1 Power supply cable (from the inverter)
- 2 Single-phase power supply cable
- 3 Connecting cable between the inverter and the REC 37.400A2 electronic cam



The connection from the inverter to the REC 37.400A2, electronic cam, must be performed as indicated in 3)(Fig. 24).

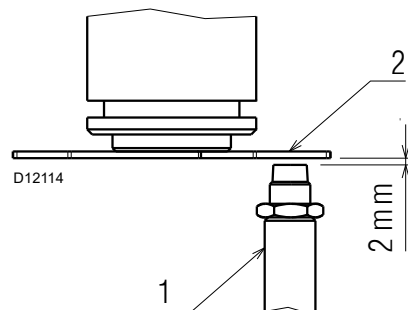

Fig. 25

4.12 Adjustment fan motor covering with external rpm

To calibrate the rpm sensor 6)(Fig. 26), proceed as follows:

- remove the cover 1) unscrewing the screws 2);
- unscrew or screw the nuts 3) - 5) and the rpm detection disc 4) so that its distance from the rpm sensor 6) is about 2 mm;
- place the plate 4) on the nut 5) and fix with the lock nut 3);
- close the cover 1) by screwing the screws 2).

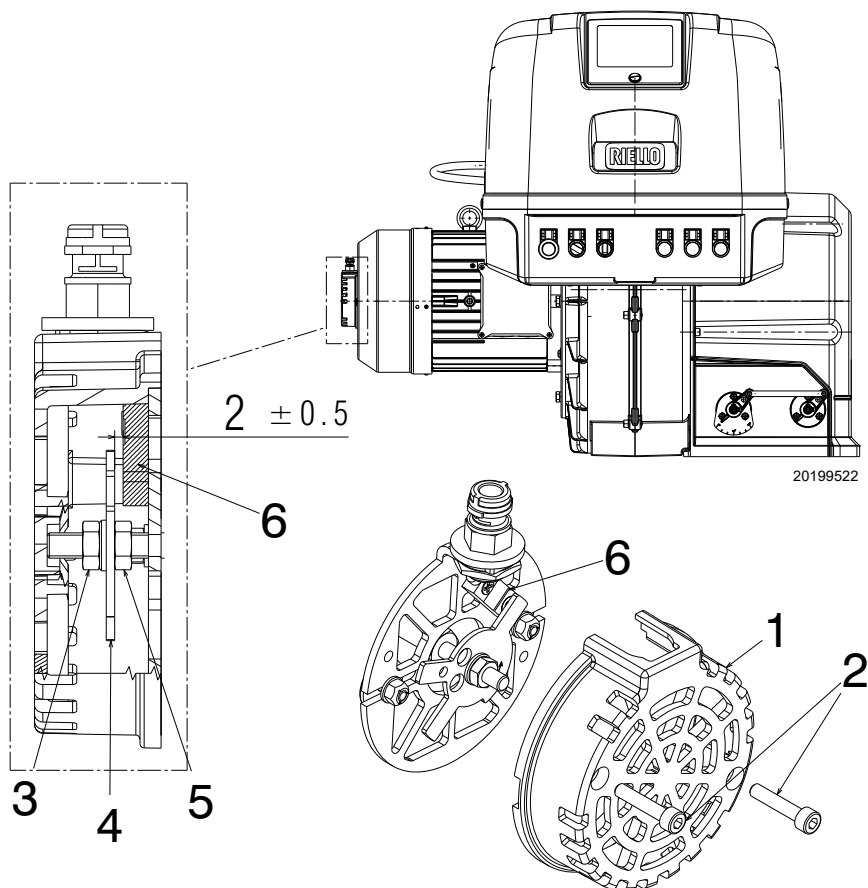

Fig. 26

Key (Fig. 26)

- 1 - Cover
- 2 - Screws for cover fixing
- 3 - Lock nut
- 4 - Rpm detection disc
- 5 - Lower nut
- 6 - Rpm sensor

5 Start-up, calibration and operation of the burner

5.1 Notes on safety for the first start-up



The first start-up of the burner must be carried out by qualified personnel, as indicated in this manual and in compliance with the standards and regulations of the laws in force.



Check the correct working of the adjustment, command and safety devices.



Refer to paragraph “Safety test - with gas ball valve closed” on page 49 before the first start-up.

5.2 Adjustments prior to ignition

The adjustments to be carried out are:

- ensure that the gas supply company has carried out the supply line vent operations, eliminating air or inert gases from the piping.
- Slowly open the manual valves situated upstream of the gas train.
- Adjust the minimum gas pressure switch to the start of the scale.
- Adjust the maximum gas pressure switch to the end of the scale.
- Adjust the air pressure switch to the start of the scale.
- Adjust the pressure switch for the valve leak detection control device (PVP Kit), if present, according to the instructions supplied with the Kit itself.
- Check the gas supply pressure by connecting a pressure gauge to the pressure test point 1)(Fig. 27) of the minimum gas pressure switch: it must be lower than the maximum allowed pressure of the gas train, as shown on the characteristics label.



An excessive gas pressure can damage the components of the gas train and lead to a risk of explosion.

- Bleed the air from the piping of the gas train, connecting a plastic tube to the pressure test point 1)(Fig. 27) of the minimum gas pressure switch. Take the vent tube outside the building so you can notice the smell of gas.
- Connect two lamps or testers to the two gas line solenoids to check the exact moment at which voltage is supplied. This operation is unnecessary if each of the two solenoids is equipped with an indicator light that signals voltage passing through.



Before starting up the burner, it is good practice to adjust the gas train so that ignition takes place in conditions of maximum safety, i.e. with gas delivery at the minimum.

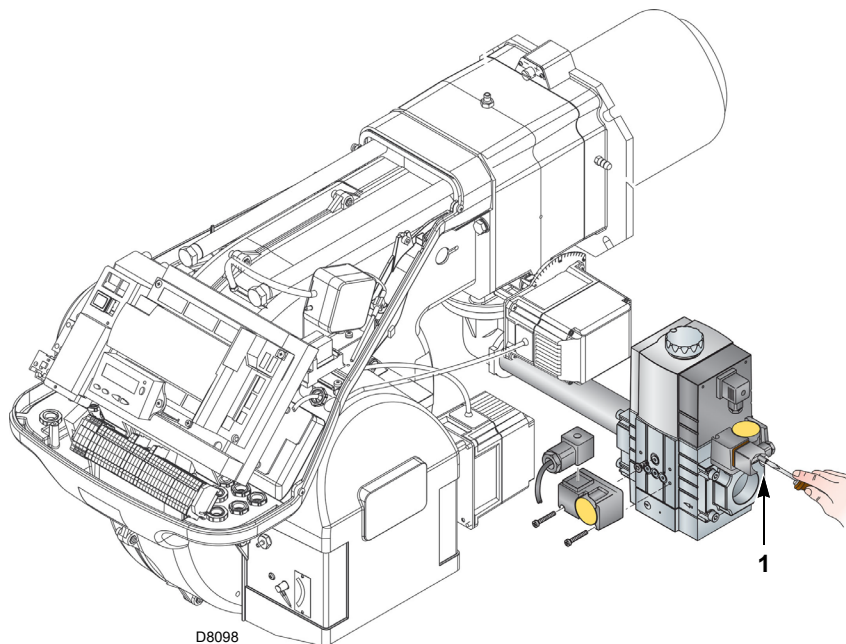

Fig. 27

5.3 Burner start-up

Feed electricity to the burner via the disconnecting switch on the boiler panel.

Close the thermostats/pressure switches and turn the switch of Fig. 28 to position "1".



DANGER

Make sure that the lights or testers connected to the solenoids, or the pilot lights on the solenoids themselves, indicate that no voltage is present.

If voltage is present, stop the burner **immediately** and check the electrical wiring.

Follow the "Start-up procedure" on page 39.

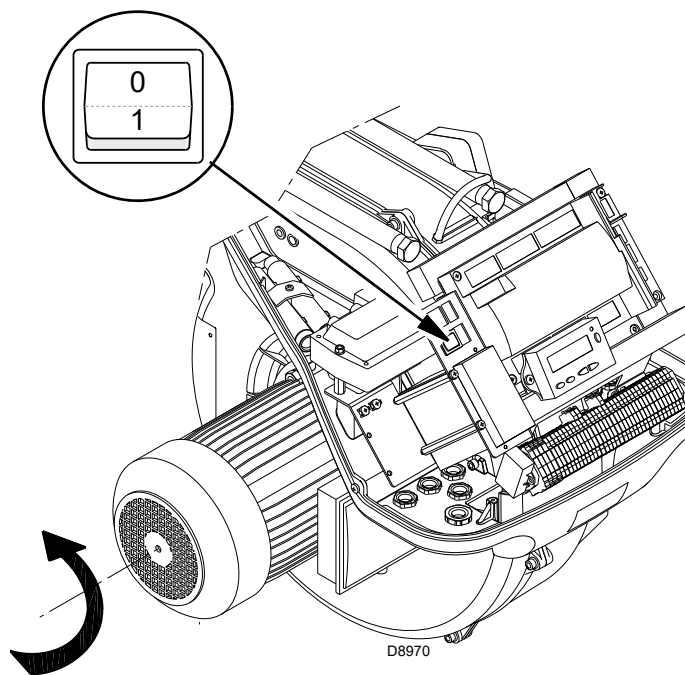

Fig. 28

5.4 Burner adjustment

5.4.1 Firing output



WARNING

For safety purposes and correct product operation, the ignition output, if it is adjustable, must be carried out by authorized personnel and in compliance with the standards and regulations of the laws in force.

5.4.2 Maximum output

The MAX output must be set within the firing rate (Fig. 2 at page 8).

Gas adjustment

Measure the gas delivery on the meter.

As a general rule, this value can be found on Tab. I at page 24, just read the gas pressure on the pressure gauge (Fig. 36 at page 50) and follow the indications given on page 24.

- If it is necessary to reduce it, lower the output gas pressure via the pressure adjuster located beneath the gas valve.
- If it needs to be increased, increase the output gas pressure via the adjuster.

Air adjustment

If necessary vary the degrees of the air servomotor.

5.4.3 Minimum output

The MIN output must be set within the firing rate (Fig. 2 at page 8).

5.5 Final calibration of the pressure switches

5.5.1 Air pressure switch

Adjust the air pressure switch after performing all other burner adjustments with the air pressure switch set to the start of the scale (Fig. 29).

With the burner working at MIN output, insert a combustion analyser in the stack, slowly close the suction inlet of the fan (for example, with a piece of cardboard) until the CO value does not exceed 100 ppm.

Slowly turn the appropriate knob clockwise until the burner goes into lockout.

Check the indication of the arrow pointing upwards on the graduated scale.

Turn the knob clockwise again, until the value shown on the graduated scale corresponds with the arrow pointing downwards, and so recovering the hysteresis of the pressure switch (shown by the white mark on a blue background, between the two arrows). Now check the correct start-up of the burner.

If the burner locks out again, turn the knob slightly anticlockwise. During these operations it may be useful to measure the air pressure with a pressure gauge.

The connection of the pressure gauge is shown in Fig. 29.

The standard configuration is that with the air pressure switch connected in absolute mode. Note the presence of a "T" connection, not supplied.

In certain applications in strong depression situations, the connection of the pressure switch does not allow it to change over. In this case it is necessary to connect the pressure switch in differential mode, applying a second tube between the air pressure switch and the fan suction line mouth.

In this case, the pressure gauge must also be connected in differential mode.



Connecting the air pressure switch in differential mode, the burner will no longer be certified according to the EN 676 standard.

5.5.2 Maximum gas pressure switch

Adjust the maximum gas pressure switch (Fig. 30) after making all other burner adjustments with the maximum gas pressure switch set to the end of the scale.

To calibrate the maximum gas pressure switch, open the tap and then connect a pressure gauge to its pressure test point.

The maximum gas pressure switch must be regulated to a value no higher than 30% of the measurement read on the gauge when the burner is working at maximum output.

After making the adjustment, remove the pressure gauge and close the tap.

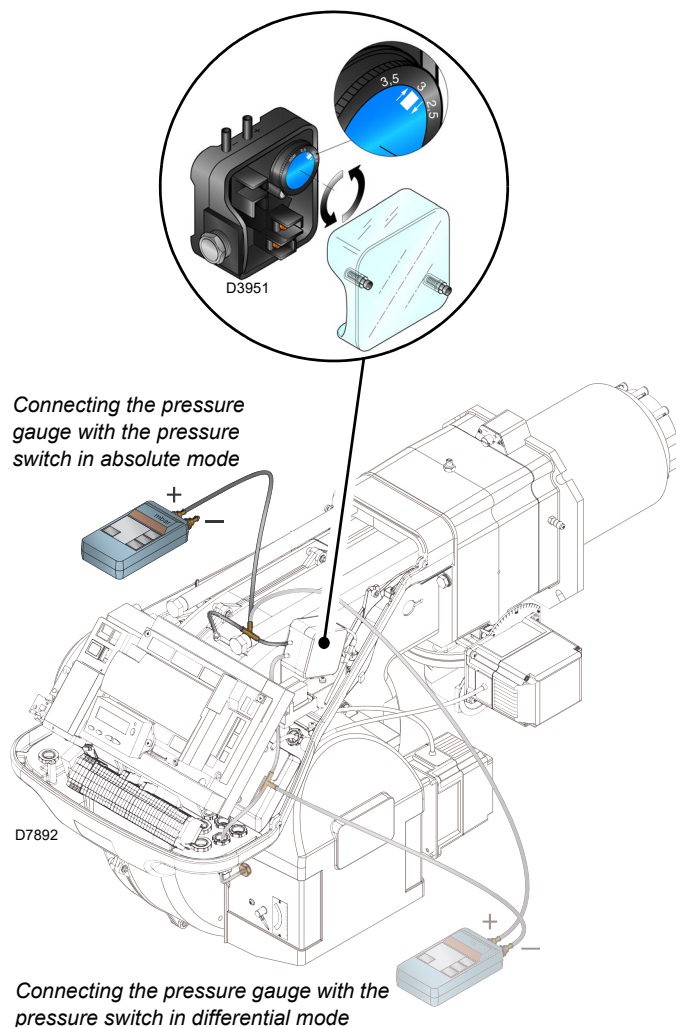

Fig. 29

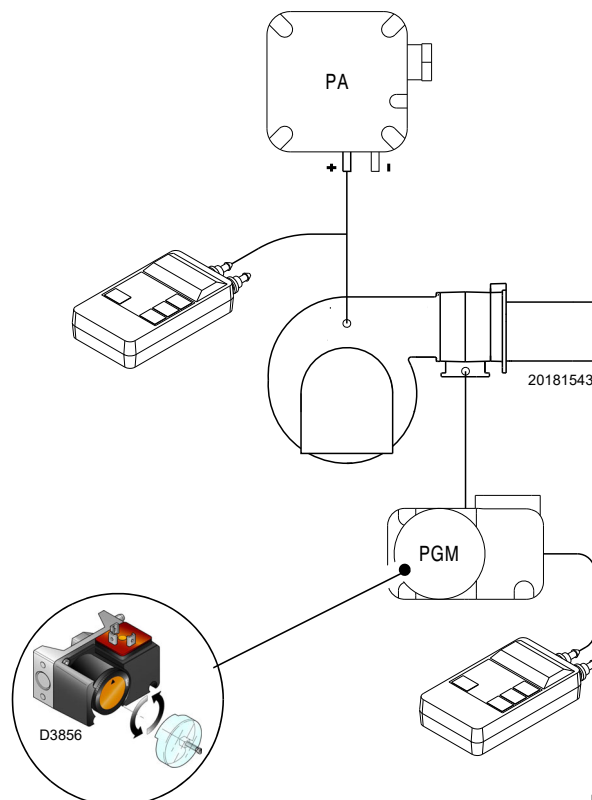

Fig. 30

5.5.3 Minimum gas pressure switch

The purpose of the minimum gas pressure switch is to prevent the burner from operating in an unsuitable way due to too low gas pressure.

Adjust the minimum gas pressure switch (Fig. 31) after having adjusted the burner, the gas valves and the gas train stabiliser.

With the burner operating at maximum output:

- install a pressure gauge downstream of the gas train stabiliser (for example at the gas pressure test point on the burner combustion head);
- choke slowly the manual gas cock until the pressure gauge detects a decrease in the pressure read of about 0.1 kPa (1 mbar). In this phase, verify the CO value which must always be less than 100 mg/kWh (93 ppm).
- Increase the adjustment of the gas pressure switch until it intervenes, causing the burner shutdown;
- remove the pressure gauge and close the cock of the gas pressure test point used for the measurement;
- open completely the manual gas cock.



1 kPa = 10 mbar

WARNING

5.5.4 PVP pressure switch kit

Adjust the pressure switch for the valve leak detection control device (PVP Kit) (Fig. 32), if present, according to the instructions supplied with the Kit itself.

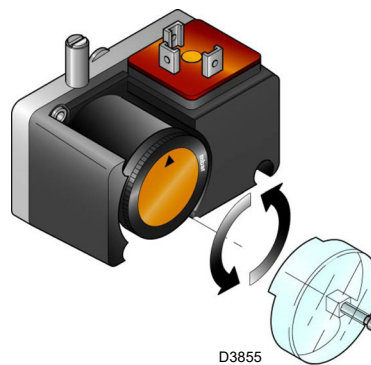

Fig. 31

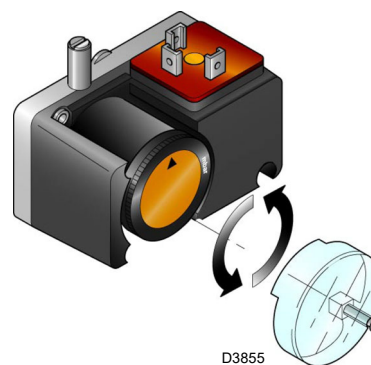

Fig. 32

5.6 Visualisation and programming mode

5.6.1 Normal mode

The Normal mode is the standard operation mode visualised on the operator panel display. It is the main level of the menu.

- Visualises the operation conditions and allows you to modify the operation point of the burner manually.
- It does not require any use of the keys of the Operator Panel.
- It allows access to the other visualisation and programming modes.

From Normal mode you can access other levels:

- Info mode (**InFo**)
- Service mode (**SEr**)
- Parameter mode (**PArA**)

Some examples in the standard conditions are given below.

5.6.1.1 Burner in stand-by display

The burner is in the heat request waiting mode, or the selector “0-1” (Fig. 28 at page 30) is at “0”.

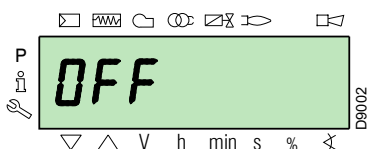

5.6.1.2 Display during starting / stopping

The display visualises the various phases of the start-up, ignition and switch-off of the burner.

In the example, the display indicates that the burner is in **Phase 30** (see diagram Fig. 33) and there are 12 seconds until the next phase.

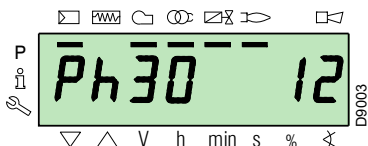

5.6.1.3 Display of the work position

The burner is working in the requested load position (in the example alongside, **78.4%**).

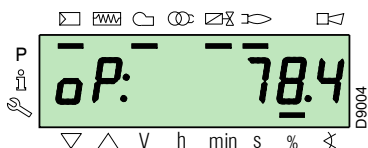

5.6.1.4 Error state message, display of the errors and information

The display visualises alternately the error code (in the example **c: 12**) and the relative diagnostic (in the example **d: 0**).

The system goes into safety mode and the message shown in the next figure appears.

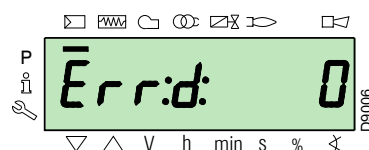
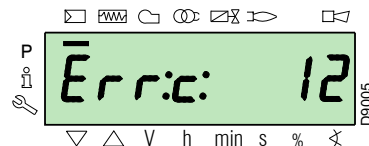

The burner goes into lockout.

The display visualises alternately the lockout code (in the example alongside **c: 4**) and the relative diagnostic (in the example **d: 3**). The red lockout lamp is on.

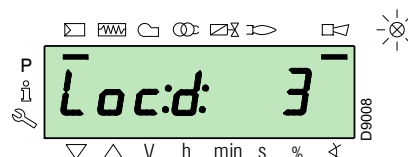
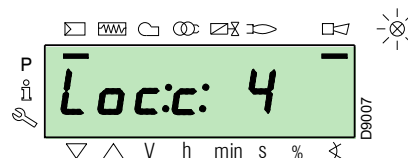

The display visualises alternately an error code and a diagnostic, which does not take the system into safety mode.

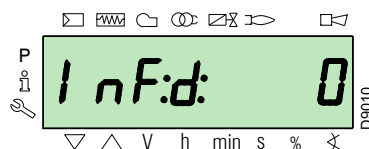
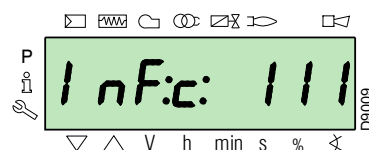

5.6.1.5 Reset procedure

The burner is in lockout when the red indicator light on the operator panel is lit up, and the display visualises the lockout code (in the example alongside **c: 4**) and the relative diagnostics (in the example **d: 3**) alternately.

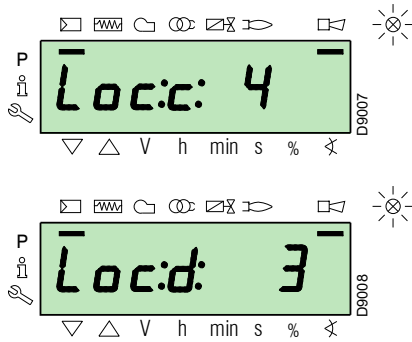

To reset, press the “**i/reset**” key for 1 s: the display will show “**rESEt**”. When the key is released, the lockout signal will disappear and the red indicator light will switch off. The flame control is reset.

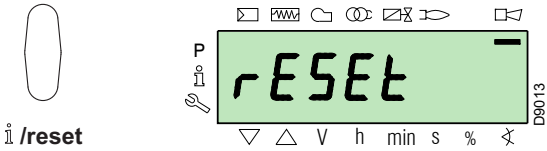

5.6.1.6 Manual lockout procedure

If necessary, it is possible to manually block the flame control and, consequently, the burner, by pressing the key “**i/reset**” simultaneously with any other key of the operator panel.



With the selector “**0-1**” (Fig. 28 at page 30), the burner does not stop immediately, but the switch-off phase is activated.

5.6.1.7 Manual operation procedure

After the adjustment of the burner and the setting of the points on the modulation curve, it is possible to manually check the operation of the burner along the entire curve.

Example:

the burner is working at the requested load percentage: 20%.

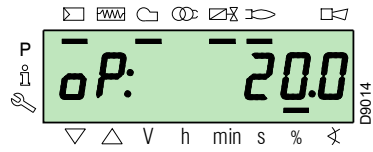

Press the “**F**” key for 1 second: “**LoAd**” is displayed and the load percentage flashes.

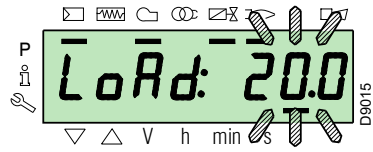

Releasing the “**F**” key, the standard visualisation appears, with the current load percentage flashing: this means that the burner is working in Manual mode (any outside adjustment is excluded and only the safety devices are active).

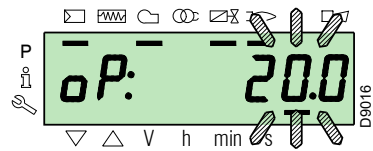

Keep the “**F**” key pressed and, with the keys “**+**” or “**-**”, increase or decrease the load percentage.

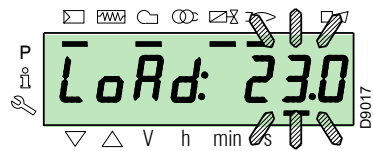

To exit manual mode, press the keys “**+**” and “**-**” (**ESC**) simultaneously for 3 seconds: the burner will work in Automatic mode and the output will depend on the thermostat/adjustment pressure switch (TR).

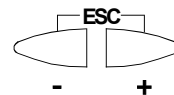

5.6.2 Info mode

The **Info mode (InFo)** visualises general system information. To access this level you must:

- press the “**i/reset**” key for 1-3 s.
- Release the key immediately when the display shows “**InFo**”.

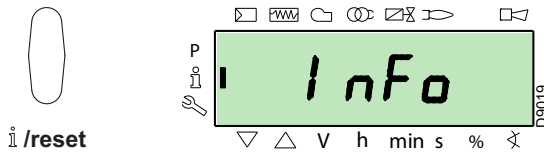

The list of parameters (in the sequence in which they are displayed) is shown in Tab. J.

No.	Parameter
167	Volumetric delivery of fuel in the unit of measurement selected
162	Operation time with flame
163	Operation time
164	No. of resettable ignitions
166	Total no. of ignitions
113	Identification code of the burner
107	Software version
108	Software variation
102	Flame control test date
103	Identification code of the flame control
104	Identification number of the group of parameters set
105	Version of the group of parameters
143	Reserved
End	

Tab. J

5.6.3 Service mode

The **Service mode (SEr)** visualises the error log and certain technical information about the system. To access this level you must:

- press the “**i/reset**” key for more than 3 s.
- Release the key immediately when the display shows “**SEr**”.

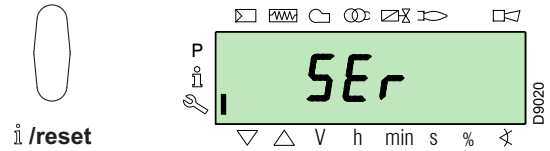

The list of parameters (in the sequence in which they are displayed) is shown in Tab. K.

No.	Parameter
954	Flame intensity (%)
960	Actual fuel which passes in units of volume / h (m ³ /h, l/h, ft ³ /h, gal/h)
121	Manual setting of output Not defined = automatic operation
922	Position of the servomotors (expressed in degrees, symbol \otimes) 0 = fuel 1 = air
161	Number of errors
701÷725	Log of the errors: 701-725.01, Code

Tab. K

5.6.3.1 Operating mode on Info Mode and Service Mode

After access to these levels, the display visualises the number of the parameter (flashing) on the left, and the corresponding value on the right.

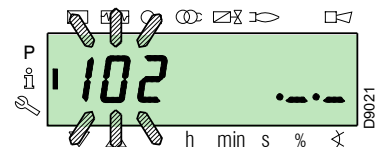

If the value is not displayed, press the “**i/reset**” key for 1 to 3 seconds

To return to the Parameter List, press the “**i/reset**” key for more than 3 s, or press the keys “**+**” and “**-**” (**ESC**) simultaneously.

To move on to the next parameter, press the “**+**” or “**i/reset**” key for less than 1 s. At the end of the list, the display visualises “**End**”.

To move back to the previous parameter, press the key “**-**”.

To return to the Normal/Standard Visualisation Mode, press the “**i/reset**” key for more than 3 s, or press the keys “**+**” and “**-**” (**ESC**) simultaneously.

For a moment the display will show “**OPeAte**”.

5.6.4 Parameters Mode

The **Parameters Mode (ParA)** displays and allows you to modify/programme the parameters list on page 43.

The factory-set parameters are not visible.

To access this level it is necessary to follow the **Access procedure with password**.

5.6.4.1 Access procedure with password

Press the “F” and “A” keys simultaneously for 1s.

For a moment the display will show “CodE”, and immediately after you will see 7 dashes, the first one flashing.

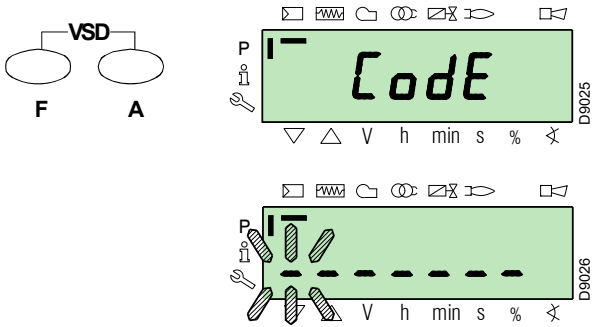

With the keys “+” and “-” select the first character of the password (letter or number), and confirm by pressing the key “i/reset”.

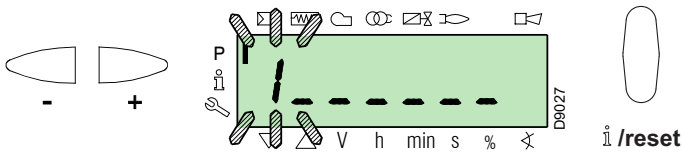

Once you have confirmed, the sign “-” will appear. Continue in the same way for the other characters.

After inserting the last character of the password, confirm by pressing the key “i/reset”: if the password inserted is correct you will see “PARA” for a few seconds, then you can access the various groups of parameters.

With the keys “+” and “-” select the group you require.

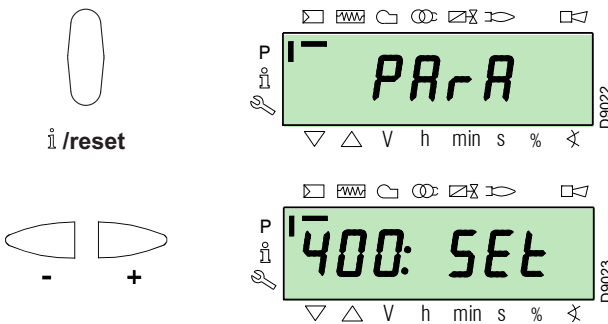

If the password inserted is incorrect, the message “Error” will appear for a moment. It is then necessary to repeat the procedure.



The password must only be communicated to the qualified personnel or the Technical Assistance Service, and must be kept in a safe place.

Once the access procedure has been carried out, the display will show “PARA” for a few seconds.

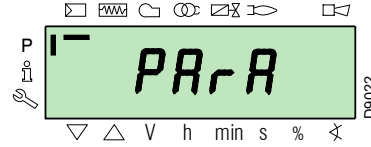

Select the group of parameters with keys “+” and “-”, and confirm by pressing the key “i/reset”.

Within the group you have chosen, scroll through the list with the keys “+” and “-”. At the end of the list, the display visualises “End”.

To return to Normal visualisation mode, simultaneously press the keys “+” and “-” (ESC) twice.

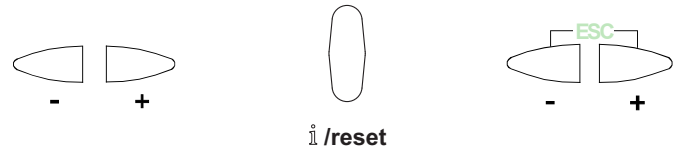

5.6.4.2 Assigning parameter levels

The parameters level is subdivided into groups as shown in Tab. L.

No.	Parameter
100: ParA	General parameters Information and identification data of the system.
200: ParA	Checks on the burner Type of operation, intervention and safety times of the various phases.
400: Set	Air/fuel modulation curve Setting of air/fuel adjustment points
500: ParA	Positioning of servomotors Choice of positions of the air/fuel servomotors in the various phases.
600: ParA	Servomotors Setting and addressing of the servomotors.
700: HIST	Log of the errors: Choice of different visualisation modes for the errors log.
900: dAtA	Process information Visualisation of information for the remote management of the burner.

Tab. L



All the parameters are checked in the factory. Modification/tampering may compromise the good operation of the burner and cause injury to people or damage to things. In any case, modifications must be carried out by qualified personnel.

To modify a parameter, refer to the **Parameter modification procedure**.

5.7 Parameter modification procedure

After accessing the level and group of parameters, the display visualises the number of the parameter (flashing) on the left, and the corresponding value on the right.

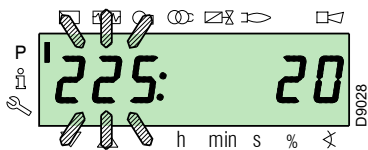

If the value is not visualised, press the key “i/reset” for 1 - 3 seconds.

An example of how to modify the parameter relating to **pre-purging time** (no.225) is given below.

Press the key “i/reset”: the value **20** (seconds) will appear.

NOTE:

The unit of measurement of the time is not visualised but is understood in seconds.

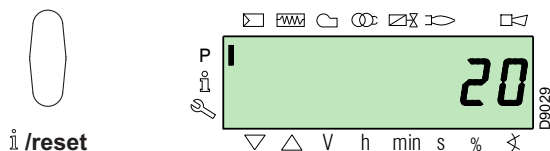

Press the key “+” and increase the value to **25** seconds (flashing). Press the key “i/reset” to confirm and store.

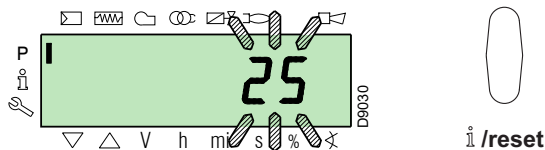

To return to the list of parameters, press the keys “+” and “-” (ESC) simultaneously.

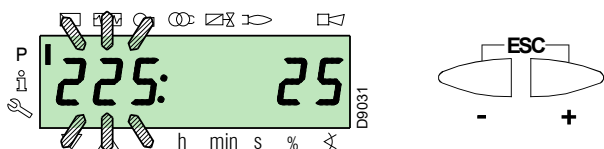

5.7.1 Procedure for inserting and adjusting points on the modulation curve

Nine adjustment/calibration points (P1 ÷ P9) can be inserted in the flame control for each servomotor, varying their position by degrees and, consequently, the quantity of air and fuel introduced.

The **ignition point P0** is independent of the minimum modulation value. This means that, in the event of difficulty, it is possible to switch on the burner at a value other than the modulation minimum (**P1**).

To access the **Parameter mode** (group 400) referring to the Access procedure with password.

To insert or adjust a point, proceed as follows.

Using the keys “+” and “-” insert/select the curve point you want and wait for it to flash: this means that the servomotors are now positioned on the values shown on the display and which correspond to the point previously set.

It is now possible to insert/modify the position by degrees.



Il valore impostato non necessita di conferma.

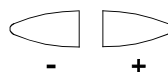

For the fuel servomotor, keep the key “F” pressed (the position in degrees flashes) and press the keys “+” or “-” to increase or decrease the value.



For the air servomotor, keep the key “A” pressed (the position in degrees flashes) and press the keys “+” or “-” to increase or decrease the value.



To adjust the speed of the inverter (expressed in % and that is **50 Hz = 100 %**), keep the buttons “F” and “A” simultaneously pressed, the percentage position blinks and press buttons “+” or “-” to increase or decrease the value.

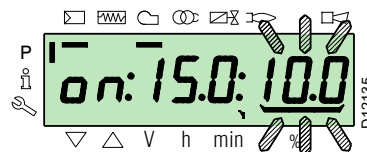
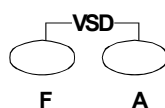

Select another point, or exit this area by pressing the keys “+” and “-” (ESC) simultaneously.

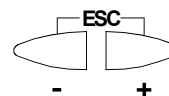

5.7.2 CALC function

The diagram (Fig. 33) shows how the fuel modulation curve is modified if the values of point “P5” are changed. By keeping the “+” key pressed for more than 3 s, the points from “P6” to “P8” are recalculated. By keeping the “-” key pressed for more than 3 s, the points from “P4” to “P2” are recalculated.

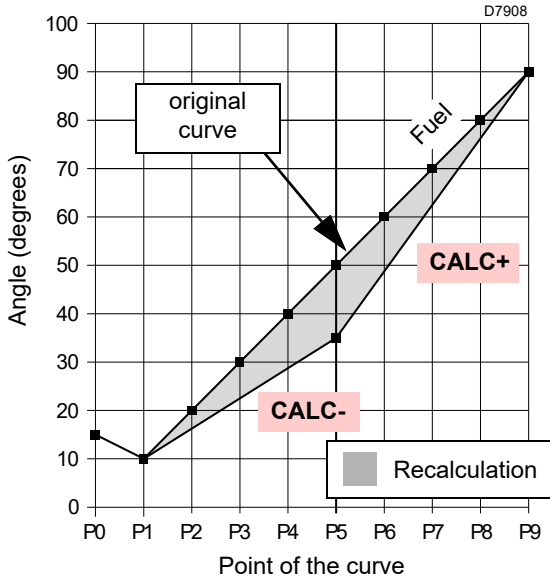

Fig. 33

The diagram of (Fig. 34) shows the fuel modulation curve when, after the modification of point “P5”, the recalculations of all the other points is not carried out.

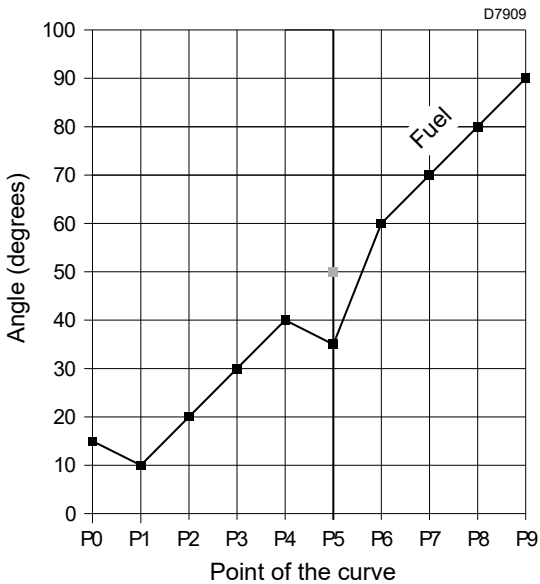

Fig. 34

5.7.3 Modification of parameter “acceleration / deceleration ramp”

The burner leaves the factory with the parameters 522 (acceleration) and 523 (deceleration) already set.

If the operator needs to modify them, proceed as follows:

Access the Parameters Level referring to “Access procedure with password” on page 36.

Using the “+” key select the parameters group 500:



Using the “+” key select the parameters group 522 (acceleration):

press the “info” key to change parameter 522.

The set value must be **greater than** at least 20% of the parameter “ACCELERATION RAMP” of the Inverter.



Example:

522 at 12s ----> Inverter parameter at 10s

522 at 10s ----> Inverter parameter at 8s

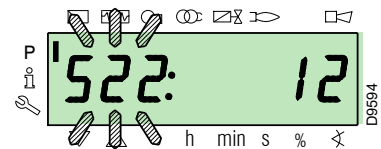

With the key “+”



Select the parameter 523 (deceleration):

press the “info” key to change parameter 523.

The set value must be **greater than** at least 20% of the parameter “DECCELERATION RAMP” of the Inverter.



Example:

523 at 12s ----> Inverter parameter at 10s

523 at 10s ----> Inverter parameter at 8s

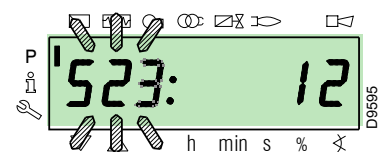

5.8 Start-up procedure

Check that the operator panel display shows the heat request and **“OFF Upr”**: this means it is necessary to set the modulation curve of the burner.

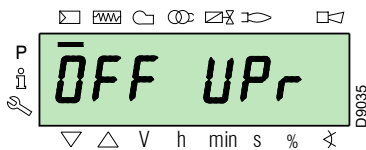

Access the Parameters Level referring to Access procedure with password.

The display screen displays the parameters group **400**.

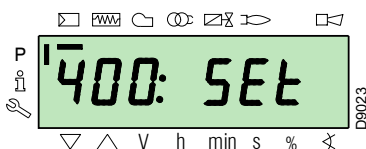

Press the **“+”** button and select the parameters group **600**:



Confirm with the key **“i/reset”**



Scroll the parameters with the **“+”** button, until parameter **641** (VSD speed standardisation) is selected.

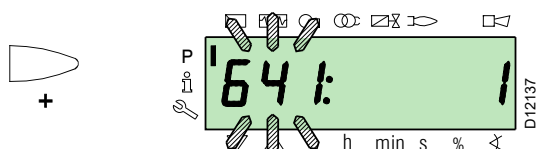

Set parameter **641 = 1**.

Press the **“i/reset”** key, start the **“VSD speed standardisation”** phase.



See the specific manual for the correct inverter parametrization.

The air servometer opens the damper at 90° and simultaneously begins the inverter start phase when the speed/frequency max is reached.

Phase 22:

Start of the fan motor.

If the standardisation operation is successful, the parameter is reset to 0.

Negative values indicate errors.

Phase 24:

The burner goes to the pre-purging position, the air servomotor opens the damper at 90°.

Phases 80, 81, 82, 83:

These phases relate to the valve seal test.

Phase 30:

The count of the pre-purging time pre-set in the factory begins.

Phase 36:

The burner goes to its switch-on position, point **“P0”**, defined in Tab. M at page 40: the display shows a flashing **“P0”** indication.

If the value proposed is adequate, **confirm using the “+” button**.

Otherwise, modify the ignition point (see the section Procedure for inserting and adjusting points on the modulation curve).

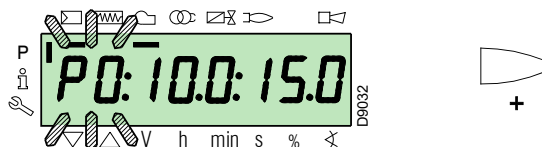

The values shown in the figure are purely for indication purposes.

Phase 38:

The ignition phase begins and the spark goes off.

Phase 40:

The gas valves open (the count of the safety time begins). Using the appropriate visor check there is a flame and that the combustion parameters are correct.

If necessary, vary the degrees of opening/closing of the air, fuel and VSD servomotors.

If the flame control goes into lockout, press the keys **“+”** and **“-”** (**ESC**) simultaneously: the display visualises alternately the lock-out code for flame absence **c: 4**) and the relative diagnostic (**d: 3**).

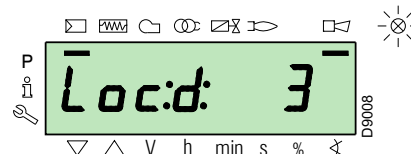
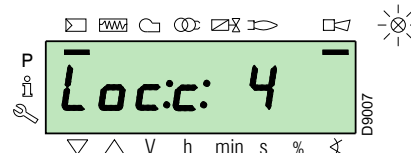
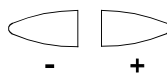

Solve the problem, referring to the paragraph Ignition failure.
To unlock, see Reset procedure. The display visualises “**OFF Upr**”.

Repeat the **Start-up procedure**.



WARNING

The values previously inserted remain stored.

Once the ignition has occurred (point “**P0**”), proceed with the calibration of the modulation curve.

Press the button “**+**”: the display visualises the indicator “**P1**” flashing and proposes the same settings as point “**P0**”.

Press button “**+**” again: the display shows “**CALC**” for a few seconds.

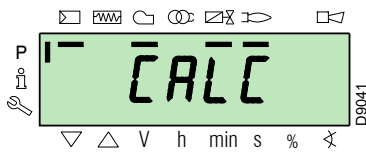

The flame control will automatically report the same values set in points “**P0**” and “**P1**” at points “**P2**” to “**P8**”.



IMPORTANT

The purpose of this is to reach point “**P9**” to regulate/determine the maximum operation output.

Press “**+**” until point “**P9**” is reached.

Once point “**P9**” is reached wait for the display to show the flashing indicator “**P9**” proposing the same settings as point “**P0**”.

Now it is possible to change this value to obtain the maximum operating power desired.

If the gas pressure is insufficient, despite opening the gas servomotor to a maximum of 90°, it is necessary to use the gas valve stabiliser.

After adjusting point “**P9**” keep the “**-**” key on the display pressed for about 5 seconds, “**CALC**” appears for a few seconds.

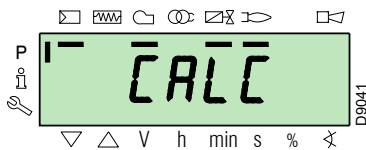

The flame control will automatically calculate the points from “**P8**” to “**P2**”, distributing them in a straight line. These are theoretical and must be checked.

Check that the settings of point “**P8**” are adequate.

If not, modify the point.

Proceed in sequence, with the “**-**” button, up to point “**P1**”.

It is possible to modify point “**P1**” to obtain a minimum modulation point different to the ignition point (“**P0**”).



IMPORTANT

Before moving on from one point to the next, wait for the servomotors to reach the position visualised on the display.

During the adjustment of each point, work on the air and gas servomotors, without modifying the position of the gas valve stabiliser.

Halfway through the procedure (i.e. around point **P4** or **P5**), you are advised to measure gas delivery and check that the output is about 50% of the maximum output.

If this is not the case, work also on the gas valve stabiliser: in this case however, it is necessary to revise the calibrations of all the points previously set.

Once the calibration of point “**P1**” is completed, confirm by pressing the keys “**+**” and “**-**” (**ESC**) simultaneously: parameter “**546**” will appear.

If you want to make the burner work on the entire modulation curve, press the “**+**” and “**-**” (**ESC**) keys simultaneously: in this way, parameter “**546**” will automatically be assigned the value of 100% and parameter “**545**” will have a value of 20%.

If you want to make the burner work on just a part of the modulation curve, modify the parameters “**546**” and “**545**” according to the Parameter modification procedure.

Press the keys “**+**” and “**-**” (**ESC**) simultaneously twice, the display will show the current load position.

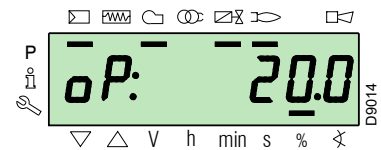
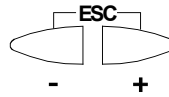

Factory settings

Point of the curve	Burner	
P0	air	15°
	gas	15°
	VSD	100°

Tab. M



WARNING

At the end of the **Start-up procedure** it is necessary to carry out a **Backup**, which is used to memorise the parameters and the data in the flame control within the display RD121...

This operation allows the parameters and the points of the modulation curve to be restored in the event of problems.

It is advisable to perform a backup every time that a parameter is changed!

For the procedure see Backup.

5.9 Backup / Restore procedure

At the end of the **Start-up procedure** it is wise to carry out a backup, creating a copy of the data memorised on the REC, in the RDI 21 display panel.

This will allow the data to be used for programming a new REC or to return to the memorised settings of the same REC.



WARNING

We suggest that this operation be carried out at the end of any intervention that involves modifications to what has been set on the cam.

This will allow you to carry out a restore in a simple manner on a new cam supplied as a replacement part, without having to reprogramme the system.

5.9.1 Backup

To perform the backup, proceed as follows:

- access the Parameters Level referring to Access procedure with password.

The display screen displays the parameters group **400**.

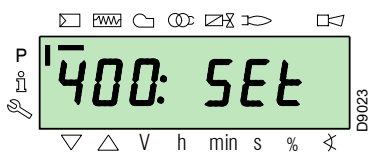

With the key "-":



Select the parameters group **000**:

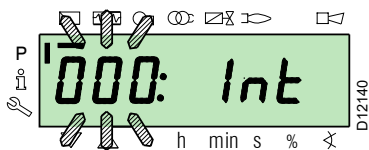

The **000** parameter blinks, confirm using the "i/reset" key:



i/reset

The display screen shows parameter **050** blinking:



Confirm with the key "i/reset":



i/reset

The parameter **bAC_UP** appears on the display screen:

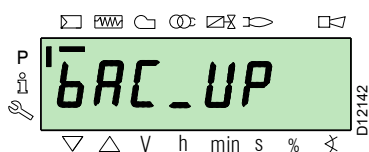

confirm with the key "i/reset":



i/reset

The display screen shows the following value:



Use the button "+":



The value will be set to **1**. Value 1 is flashing:

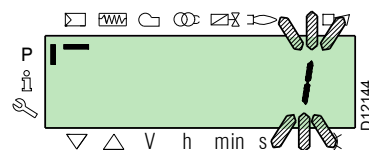

confirm with the button "i/reset" to activate the **backup** process.



i/reset

The value **1** appears on the display screen:



After approx 5 seconds (it depends on the duration of the programme), the 0 value appears on the display screen, this is to indicate that the backup process has been completed correctly.



NOTE:

If an error occurs during the backup process, the display screen shows a negative value.
Refer to diagnostic code 137 to determine the cause of the error (see section Error codes list).



It is advisable to perform a backup every time that a parameter is changed, after checking that the modification carried out is correct.

5.9.2 Restore



Use this procedure when replacing equipment with a spare part code. In this way it is possible to have the default parameters already memorised or those memorised during the start-up.

This procedure cannot be carried out on equipment coming from other burners.

To perform the restore procedure, proceed as follows:

- access the Parameters Level referring to Access procedure with password.

The display screen displays the parameters group **400**.

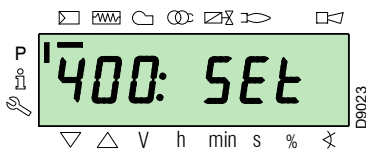

With the key “-”:



Select the parameters group **000**:

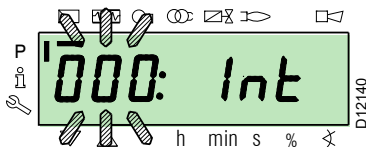

The **000** parameter blinks, confirm using the “i/reset” key:



i /reset

The display screen shows parameter **050** blinking:

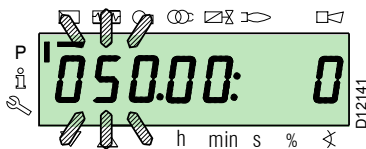

Confirm with the key “i/reset”:



i /reset

The parameter **bAC_UP** appears on the display screen:

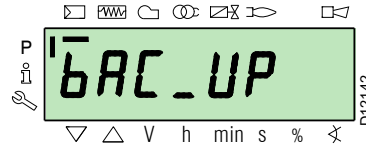

With the key “+”



select the **rEStorE** parameter

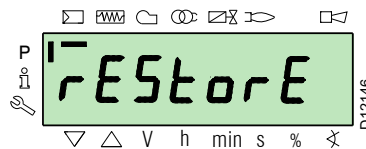

Confirm with the key “i/reset”:



i /reset

The display shows the following value.



Use the button “+”:



The value will be set to **1**. Value 1 is flashing:

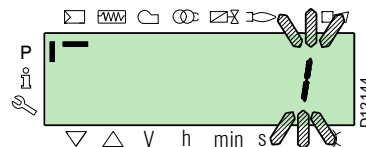

confirm with the button “i/reset” to activate the **restore** process.



i /reset

The value **1** appears on the display screen:



After approx 8 seconds (it depends on the duration of the programme), the **0** value appears on the display screen, this is to indicate that the restore process has been completed correctly.



NOTE:

When the restore process is successfully completed, the **0** value is shown on the display screen.

Err C information: 136 D: 1 (restore process initialised) is displayed for a brief moment.



IMPORTANT

At the end of the restore process, it is necessary to check the sequence of functions and the list of parameters.

5.9.3 Parameter list

Parameter		No. elements	Unit of measure	Modification	Value range		Degree of accuracy	Default setting	Access mode
No.	Description				Min.	Max.			
000 INTERNAL PARAMETERS									
050	Start backup/restore process via RDI21... / PC TOOL (set the parameter to 1) Index 0 = create backup Index 1 = perform restore Negative values indicate errors	2	-	Modification	-99	2	1	0; 0	Service mode
055	Burner identification number created from the backup on RDI21...	1	-	Reading only	0	99999999	1	0	Service mode
056	ASN number created by the backup on RDI21...	8	-	Reading only	0	127	1	0	Service mode
057	Software Version created by the backup on RDI21...	1	-	Reading only	0x100	0xFFFF9	1	0	Service mode
100 GENERAL PARAMETERS									
102	Flame control identification date	1	-	Reading only	0	255	1		Info mode
103	Flame control identification number	1	-	Reading only	0	65535	1		Info mode
104	Identification number of the group of parameters set	1	-	Reading only	0	255	1	30	Info mode
105	Version of the group of parameters set	1	-	Reading only	0	0xFFFF	1	V 01.08	Info mode
107	Software version	1	-	Reading only	0	0xFFFF9	1	V 03.30	Info mode
108	Software variation	1	-	Reading only	0	225	1	1	Info mode
111	ASN number to verify the ASN number created by the backup on RDI 21...	8	-	Reading only	0	127	1	0	Service mode
113	Burner identification	1	-	Modification	0	99999999	1	Not defined	Info Mode with password Service Mode
121	Manual setting of output Not defined = automatic operation	1	%	Modification / zero setting	0%	100%	0.1%	Not defined	Info mode
123	Minimum output step position Index 0: BACS output Index 1: output of the external load regulator, analogue. Index 2: output of the external load regulator contacts.	3	%	Modification	0%	100%	0.1%	0% ; 1%; 0%	Service mode
124	Beginning flame loss test (TUV test) (define the parameter at 1) (switch of flame loss fuel valves) A negative value indicates an error (see code 150)	1	-	Modification	-6	1	1	0	Service mode
125	Frequency of main power supply 0 = 50 Hz 1 = 60 Hz	1	-	Modification	0	1	1	0	Service Mode
126	Brightness of display	1	%	Modification	0%	100%	1%	75%	Service Mode
128	Fuel meter: Led pulse valence (led pulses / volumetric flow units)	1	-	Modification	0	400	0.01	0	Service Mode
130	Eliminate visualisation error chronology To eliminate the visualisation, set the parameter to 1, then to 2 Answer 0: process successful Answer -1: timeout of 1_2 - sequence	1	-	Modification	-5	2	1	0	Service Mode

Parameter		No. elements	Unit of measure	Modification	Value range		Degree of accuracy	Default setting	Access mode
No.	Description				Min.	Max.			
133	Default output for TÜV test: Not valid for TÜV test when output is activated 2,000 10,000 = low flame or first / second / third stage	1	%	Modification / zero setting	20%	100%	0.1%	Not defined	Service Mode
141	Remote management of flame control 0 = off 1 = Modbus 2 = reserved	1	-	Modification	0	2	1	0	Service Mode
142	Standby time before a new attempt in event of communication fault Set values: 0 = not active 1 = 7200 s	1	s	Modification	0s	7200s	1s	120s	Service Mode
143	Reserved	1	-	Modification	1	8	1	1	Info Mode
144	Reserved	1	s	Modification	10s	60s	1s	30s	Service Mode
145	Peripheral address for Modbus Set values: 1 ... 247	1	-	Modification	1	247	1	1	Service Mode
146	Baud Rate for Modbus Set values: 0 = 9600 1 = 19200	1	-	Modification	0	1	1	1	Service Mode
147	Parity for Modbus 0 = none 1 = odd 2 = even	1	-	Modification	0	2	1	0	Service Mode
148	Selection of the burner operation during the interruption of the switch-over with the system of remote management. With modulating operation the settings of the values are the following: 0...19.9 = burner switched off 20...100 = 20...100% modulation field of the burner. With stage operation : 0 = burner off P1, P2, P3 No setting = no function in the event of communication interruption	1	%	Modification / zero setting	0%	100%	0.1%	Not defined	Service Mode
161	Total number of errors	1	-	Reading only	0	65535	1	0	Info mode
162	Hours of operation (that can be reset)	1	h	Reset	0h	999999h	1h	0h	Info mode
163	Total hours of power supply to flame control	1	h	Reading only	0h	999999h	1h	0h	Info mode
164	Total number of start-ups (that can be reset)	1	-	Reset	0	999999	1	0	Info mode
166	Total number of start-ups	1	-	Reading only	0	999999	1	0	Info mode
167	Volumetric delivery of fuel in the selected unit of measurement (that can be reset)	1	m ³ , l, ft ³ , gal	Reset	0	99999999	1	0	Info mode
200 BURNER CHECKS									
201	Burner operation mode (fuel supply line, modulating/ stage, servomotors, etc.) -- = not defined (eliminate curves) 1 = Gmod 2 = Gp1 mod 3 = Gp2 mod 4 = Lo mod 5 = Lo 2 stage 6 = Lo 3 stage 7 = Gmod pneu 8 = Gp1 mod pneu 9 = Gp2 mod pneu 10 = LoGp mod 11 = LoGp 2-stage 12 = Lo mod 2 fuel valves 13 = LoGp mod 2 fuel valves 14 = G mod pneu without actuator 15 = Gp1 mod pneu without actuator 16 = Gp2 mod pneu without actuator 17 = Lo 2-stage without actuator 18 = Lo 3-stage without actuator 19 = G mod only gas actuator 20 = Gp1 mod only gas actuator 21 = Gp2 mod only gas actuator 22 = Lo mod only oil actuator	1	-	Modify/set to zero	1	22	1	Not defined	Service Mode

Parameter No.	Description	No. elements	Unit of measure	Modification	Value range		Degree of accuracy	Default setting	Access mode
					Min.	Max.			
208	Stopping of the program 0 = deactivated 1 = pre-purging (Ph24) 2 = Ignition (Ph36) 3 = Interval 1 (Ph44) 4 = Interval 2 (Ph52)	1	-	Modification	0	4	1	0	Service Mode
210	Alarm as the pre-purging phase begins; 0 = Deactivated; 1 = Activated	1	-	Modification	0	1	1	0	Service Mode
211	Uphill train fan motor	1	s	Modification	2s	60s	0.2s	2s	Service Mode
212	Maximum time to reach low flame	1	s	Modification	0.2s	10 min	0.2s	45s	Service Mode
215	Maximum repeats of safety circuit 1 = No repetition 2...15 = Number of repetitions 16 = Constant repetitions	1	-	Modification	1	16	1	16	Service Mode
221	Gas: selection of flame sensor 0 = QRB... / QRC 1 = ION / QRA	1	-	Modification	0	1	1	1	Service Mode
222	Gas: Selection of the pre-purging function 0 = deactivated 1 = activated	1	-	Modification	0	1	1	1	Service Mode
223	Maximum repeats of minimum gas pressure switch intervention 1 = No repetition 2...15 = Number of repetitions 16 = Constant repetitions	1	-	Modification	1	16	1	16	Service Mode
225	Gas: Pre-purging time	1	s	Modification	20s	60 min	0.2s	20s	Service Mode
226	Gas: Pre-ignition time	1	s	Modification	0.4 s	60 min	0.2s	2s	Service Mode
230	Gas: Interval 1	1	s	Modification	1s	60s	0.2s	2s	Service Mode
232	Gas: Interval 2	1	s	Modification	0.4 s	60s	0.2s	2s	Service Mode
233	Gas: Post-combustion time	1	s	Modification	0.2s	60s	0.2s	8s	Service Mode
234	Gas: Post-purging time (no extraneous light test)	1	s	Modification	0.2s	108 min	0.2s	0.2s	Service Mode
236	Gas: Minimum gas pressure switch input 0 = deactivated 1 = Minimum gas pressure switch (upstream of the fuel valve 1 (V1)) 2 = Valve control via the minimum pressure switch (between fuel vale 1 (V1) and 2 (V2))	1	-	Modification	1	2	1	1	Service Mode
237	Gas: Maximum gas pressure switch / POC Input 0 = Deactivated 1 = Maximum gas pressure switch 2 = POC	1	-	Modification	1	2	1	1	Service Mode
239	Gas: Intermittent operation 0 = Deactivated 1 = Activated	1	-	Modification	0	1	1	1	Service Mode
241	Gas: Valve leak detection test 0 = test deactivated 1 = valve leak detection test at start up 2 = valve leak detection test at shutdown 3 = valve leak detection test at start-up and at shut-down	1	-	Modification	0	3	1	2	Service Mode
248	Gas: Post-purging time (t3) (at deactivation of the load (LR)) - ON	1	s	Modification	1s	108 min	0.2s	1s	Service Mode
261	Oil: Selection of flame sensor 0 = QRB... / QRC... 1 = ION / QRA...	1	-	Modification	0	1	1	0	Service Mode
265	Oil: Pre-purging time	1	s	Modification	15s	60 min	0.2s	15s	Service Mode
266	Oil: Pre-ignition time	1	s	Modification	0.6s	60 min	0.2s	2s	Service Mode
270	Oil: Interval 1	1	s	Modification	0.4 s	60 min	0.2s	2s	Service Mode
272	Oil: Interval 2	1	s	Modification	0.4 s	60 min	0.2s	2s	Service Mode
273	Oil: Post-combustion time	1	s	Modification	0.2s	60s	0.2s	8s	Service Mode
274	Oil: Post-purging time (no extraneous light test)	1	s	Modification	0.2s	108 min	0.2s	0.2s	Service Mode
276	Oil: Minimum input oil pressure switch 0 = deactivated 1 = activated from phase 38 2 = activated from safety time (TSA)	1	-	Modification	1	2	1	1	Service Mode

Parameter		No. elements	Unit of measure	Modification	Value range		Degree of accuracy	Default setting	Access mode
No.	Description				Min.	Max.			
277	Oil: Maximum oil pressure switch / POC Input 0 = deactivated 1 = maximum oil pressure switch 2 = POC	1	-	Modification	1	2	1	1	Service Mode
279	Oil: Intermittent operation 0 = deactivated 1 = activated	1	-	Modification	0	1	1	1	Service Mode
281	Oil: selection transformer ignition phase TA 0 = brief pre-ignition (Ph38) 1 = long pre-ignition (with fan) (Ph22)	1	-	Modification	0	1	1	1	Service Mode
284	Oil: Post-purging time (t3) (at deactivation of the load (LR)) - ON	1	s	Modification	1s	108 min	0.2s	1s	Service Mode
400 AIR / FUEL MODULATION CURVES									
401	Checking servomotor fuel (only curve setting)	13	(°)	Modification	0°	90°	0.1°	0°; 0°; 15°; Not defined	Service Mode
402	Checking servomotor air (only curve setting)	13	(°)	Modification	0°	90°	0.1°	0°; 90°; 45°; Not defined	Service Mode
403	VSD control curve ratio (only curve setting)	13	(°)	Modification	20°	100°	0.1°	0°; 100°; 50°; Not defined	Service Mode
500 POSITIONING OF SERVMOTORS									
501	Position of the fuel servomotor in absence of flame Index 0 = standby position Index 1 = pre-purging position Index 2 = post-purging position	3	(°)	Modification	0°	90°	0.1°	0°; 0°; 15°	Service Mode
502	Position of the air servomotor in absence of flame Index 0 = standby position Index 1 = pre-purging position Index 2 = post-purging position	3	(°)	Modification	0°	90°	0.1°	0°; 90°; 45°	Service Mode
503	VSD speed without flame Index 0 = standby speed Index 1 = pre-purging speed Index 2 = post-purging speed	3	(°)	Modification	0°	100°	0.1°	0°; 100°; 50°	Service Mode
522	Acceleration	1	s	Modification	5 s	20s	1s	10s	Service Mode
523	Deceleration	1	s	Modification	5 s	20s	1s	10s	Service Mode
542	VSD/PWM activation 0 = Deactivated 1 = Activated	1	-	Modification	0	1	1	0	Service Mode
545	Minimum modulation limit Not defined = 20%	1	%	Modification / zero setting	20%	100%	0.1%	Not defined	Service Mode
546	Maximum modulation limit Not defined = 100%	1	%	Modification / zero setting	20%	100%	0.1%	Not defined	Service Mode
600 SERVMOTORS									
606	Tolerance limit for position check (0.1°) Index 0 = fuel Index 1 = air More serious position error, where a defect has certainly been detected -> Stop range: (P 606 - 0.6°) a P606	2	(°)	Modification	0.5°	4°	0.1°	1.7°; 1.7°	Service Mode
641	VSD speed standardisation control Negative value error diagnostics (see error code 82) 0 = standardisation deactivated 1 = Standardisation active	1	-	Modification	-25	1	1	0	Service Mode
642	Standardised speed Index 0 = speed 1 Index 1 = speed 2	2	-	Reading only	650	6500	0.1	Not defined	Service Mode
645	Analogue exit configuration 0 = DC 0...10 V 1 = DC 2...10 V 2 = DC 0 / 2...10 V	1	-	Modification	0	2	1	2	Service Mode
700 LOG OF THE ERRORS									
701	Error chronology: 701-725.01.Code	25	-	Reading only	0	255	1	0	Info mode
•	Error chronology: 701-725.02.Diagnostic code	25	-	Reading only	0	255	1	0	Info mode
•	Error chronology: 701-725.03.Error class	25	-	Reading only	0	6	1	0	Info mode
•	Error chronology: 701-725.04.Phase	25	-	Reading only	0	255	1	0	Info mode

Parameter		No. elements	Unit of measure	Modification	Value range		Degree of accuracy	Default setting	Access mode
No.	Description				Min.	Max.			
•	Error chronology: 701-725.05.Start-up meter	25	-	Reading only	0	99999999	1	0	Info mode
725	Error chronology: 701-725.06.Load	25	%	Reading only	0%	100%	0.1%	0%	Info mode
900 PROCESS INFORMATION									
903	Actual output Index 0 = fuel Index 1 = air	2	%	Reading only	0%	100%	0.1%	0%	Info mode
922	Position of the servomotors Index 0 = fuel Index 1 = air	2	(°)	Reading only	-50°	150°	0.01°	0°	Info mode
935	Absolute speed	1	-	Reading only	0	6553,5	0.1	0	Service mode
936	Standardised speed	1	%	Reading only	-200%	200%	0.1%	0%	Info mode
942	Heat source active 1 = output during the definition of the curves 2 = manual output 3 = BACS output 4 = analogue input output 5 = output of the external load regulator contacts	1	-	Reading only	0	255	1	0	Service mode
947	Result of the sampling of the contact (coded in bits) Bit 0.0 = 1: Minimum pressure switch Bit 0.1 = 2: Maximum pressure switch Bit 0.2 = 4: Pressure switch control valves Bit 0.3 = 8: Air pressure switch Bit 0.4 = 16: Open load check Bit 0.5 = 32: ON load check Bit 0.6 = 64: Closed load check Bit 0.7 = 128: Safety circuit Bit 1.0 = 1: Safety valve Bit 1.1 = 2: Ignition Bit 1.2 = 4: Fuel valve 1 Bit 1.3 = 8: Fuel valve 2 Bit 1.4 = 16: Fuel valve 3/ pilot valve Bit 1.5 = 32: Reset	2	-	Reading only	0	255	1	0	Info mode
950	Relay request status (coded in bits) Bit 0 = 1: Alarm Bit 1 = 2: Safety valve Bit 2 = 4: Ignition Bit 3 = 8: Fuel valve 1 Bit 4 = 16: Fuel valve 2 Bit 5 = 32: Fuel valve 3/ pilot valve	1	-	Reading only	0	255	1	0	Info mode
954	Flame intensity	1	%	Reading only	0%	100%	1%	0%	Info mode
960	Actual output	1	m ³ /h, l, h, ft ³ /h, gal/h	Reading only	0	6553,5	0.1	0	Info mode
961	Status of external modules and visualisation	1	-	Reading only	0	255	1	0	Info mode
981	Memory error: Code	1	-	Reading only	0	255	1	0	Info mode
982	Memory error: diagnostic code	1	-	Reading only	0	255	1	0	Info mode
992	Error indicators	10	-	Reset	0	0xFFFFFFFF FF	1	0	Service mode

Tab. N

5.10 Steady-state operation

Burner without modulating operation kit

Once the start-up cycle is completed, the servomotor command moves on to the thermostat/pressure switch TR that controls the pressure or the temperature in the boiler.

- If the temperature or the pressure is low (so the thermostat/pressure switch TR is closed), the burner progressively increases the output as far as the MAX value (point "P9").
- If the temperature or the pressure increases as far as the opening of the thermostat/pressure switch TR, the burner progressively reduces the output as far as the MIN value (point "P1"). And so on.
- The burner switches off when the request for heat is lower than the heat supplied by the burner at MIN output.
- The thermostat/pressure switch TL opens and the flame control carries out the switching off phase.

- The damper closes completely to reduce thermal dispersions to a minimum.

Burner with modulating operation kit

See the manual supplied with the regulator.

5.11 Ignition failure

If the burner does not switch on, there is a lockout within 3s of the electrical supply reaching the gas valve.

It may be that the gas does not arrive at the combustion head within the safety time of 3 s.

In this case, increase gas delivery upon ignition.

The arrival of the gas at the pipe coupling is shown on the pressure gauge of Fig. 36 at page 50.



In the event of a burner lockout, more than two consecutive burner reset operations could cause damage to the installation. On the third lockout, contact the Aftersales Service.



If further lockouts or burner faults occur, interventions must only be made by qualified, authorised personnel (as indicated in this manual, and in compliance with the laws and regulations currently in force).

5.12 Burner flame goes out during operation

If the flame accidentally goes out during operation, the flame control carries out a recycle (i.e. it repeats the start-up phase once, and makes a further ignition attempt).

If the flame is still absent, the flame control goes into lockout.

5.13 Stopping of the burner

The burner can be stopped by:

- intervening on the disconnecting switch of the electrical supply line, located on the boiler panel;
- removing the cover and working on the switch "0-1" of Fig. 28 at page 30;

- removing the transparent protection that covers the Operator Panel, after loosening the relative screw, and using the panel itself according to Manual lockout procedure.

5.14 Final checks (with burner operating)

<ul style="list-style-type: none"> ➤ Open the thermostat/pressure switch TL ➤ Open the thermostat/pressure switch TS 		The burner must stop
<ul style="list-style-type: none"> ➤ Turn the gas maximum pressure switch knob to the minimum end of scale position ➤ Turn the air pressure switch to the maximum end of scale position. 		The burner must stop in lockout
<ul style="list-style-type: none"> ➤ Switch off the burner and disconnect the voltage. ➤ Disconnect the minimum gas pressure switch connector. 		The burner must not start
<ul style="list-style-type: none"> ➤ Disconnect the ionisation probe wire 		The burner must stop in lockout due to firing failure

Tab. O



Make sure that the mechanical locking systems on the various adjustment devices are fully tightened.

6 Maintenance

6.1 Notes on safety for the maintenance

The periodic maintenance is essential for the good operation, safety, yield and duration of the burner.

It allows you to reduce consumption and polluting emissions and to keep the product in a reliable state over time.



The maintenance interventions and the calibration of the burner must only be carried out by qualified, authorised personnel, in accordance with the contents of this manual and in compliance with the standards and regulations of current laws.

Before carrying out any maintenance, cleaning or checking operations:



Disconnect the electrical supply from the burner by means of the main system switch.



Close the fuel interception tap.



Wait for the components in contact with heat sources to cool down completely.

6.2 Maintenance programme

6.2.1 Maintenance frequency



The gas combustion system should be checked at least once a year by a representative of the manufacturer or another specialised technician.

6.2.2 Safety test - with gas ball valve closed

It is fundamental to ensure the correct execution of the electrical connections between the gas solenoid valves and the burner to perform safely the commissioning.

For this purpose, after checking that the connections have been carried out in accordance with the burner's electrical diagrams, an ignition cycle with closed gas ball valve -dry test- must be performed.

- 1 The manual ball gas valve must be closed
- 2 The electrical contacts of the burner limit switch need to be closed
- 3 Ensures closed the contact of the low gas pressure switch
- 4 Make a trial for burner ignition

The start-up cycle must be as follows:

- Starting the fan for pre-ventilation
- Performing the gas valve seal control, if provided
- Completion of pre-ventilation
- Arrival of the ignition point
- Power supply of the ignition transformer
- Electrical Supply of solenoid gas valves

Since the manual gas ball valve is closed, the burner will not light up and its flame control will go to a safety lockout condition.

The actual electrical supply of the solenoid gas valves can be verified by inserting a tester. Some valves are equipped with light signals (or close/open position indicator) that turn on at the same time as their power supply.



IF THE ELECTRICAL SUPPLY OF THE GAS VALVES OCCURS AT UNEXPECTED TIMES, DO NOT OPEN MANUAL GAS BALL VALVE, SWITCH OFF POWER LINE; CHECK THE WIRES; CORRECT THE ERRORS AND REPEAT THE COMPLETE TEST.

6.2.3 Checking and cleaning



The operator must use the required equipment during maintenance.

Combustion

The optimum calibration of the burner requires an analysis of the flue gases. Significant differences with respect to the previous measurements indicate the points where more care should be exercised during maintenance.

Combustion head

Open the burner and make sure that all the components of the combustion head are undamaged, not deformed due to high temperature, free of ambient dirt or dust, free of rusted materials and adequately positioned.

Make sure that the gas outlet holes for the start-up, on the combustion head distributor, are free of dirt or rust deposits. If in doubt, disassemble the elbow (Fig. 37 at page 51).

Fan

Check to make sure that no dust has accumulated inside the fan or on its blades, as this condition will cause a reduction in the air flow rate and provoke polluting combustion.

Burner

Clean the outside of the burner.

Gas leaks

Make sure that there are no gas leaks on the pipes between the gas meter and the burner.

Gas filter

Replace the gas filter when it is dirty.

Flame inspection window

Clean the glass of the flame inspection window.

Boiler

Clean the boiler as indicated in its accompanying instructions in order to maintain all the original combustion characteristics intact, especially the flue gas temperature and combustion chamber pressure.

Combustion

If the combustion values found at the start of the intervention do not satisfy current standards or anyway indicate a poor state of combustion (consult the table below), contact the Technical Assistance Service for the necessary adjustments.

EN 676		Air excess		CO
		Max. output $\lambda \leq 1.2$	Max. output $\lambda \leq 1.3$	
GAS	Theoretical max. CO ₂ 0 % O ₂	CO ₂ % Calibration		mg/kWh
		$\lambda = 1.2$	$\lambda = 1.3$	
G 20	11.7	9.7	9	≤ 100
G 25	11.5	9.5	8.8	≤ 100
G 30	14.0	11.6	10.7	≤ 100
G 31	13.7	11.4	10.5	≤ 100

Tab. P

6.2.4 Safety components

The safety components must be replaced at the end of their life cycle indicated in Tab. Q. The specified life cycles do not refer to the warranty terms indicated in the delivery or payment conditions.

Safety component	Life cycle
Flame control	10 years or 250.000 operation cycles
Flame sensor	10 years or 250.000 operation cycles
Gas valves (solenoid)	10 years or 250.000 operation cycles
Pressure switches	10 years or 250.000 operation cycles
Pressure adjuster	15 years
Servomotor (electronic cam) (if present)	10 years or 250.000 operation cycles
Oil valve (solenoid) (if present)	10 years or 250.000 operation cycles
Oil regulator (if present)	10 years or 250.000 operation cycles
Oil pipes/ couplings (metallic) (if present)	10 years
Fan impeller	10 years or 500.000 start-ups

Tab. Q

6.2.5 Measuring the ionisation current

The burner is fitted with an ionisation system to check that a flame is present.

The minimum current for flame control operation is 4 µA. The Operator Panel visualises “30%” (see Parameter list, parameter no. 954).

The burner provides a much higher current, so controls are not normally required.

However, if it is necessary to measure the ionisation current, disconnect the plug-socket on the ionisation probe cable and insert a direct current microammeter with a base scale of 100 µA - see Fig. 35.



Carefully check the polarities!

6.2.6 Checking the air and gas pressure on the combustion head

To carry out this operation a pressure gauge must be used to measure the air and gas pressure at the combustion head, as shown in Fig. 36.

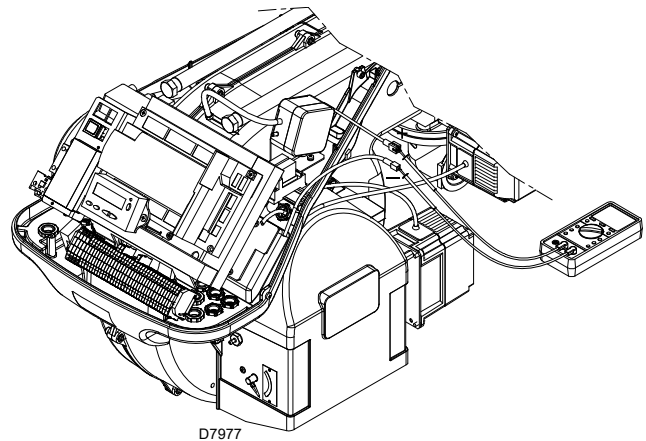

Fig. 35

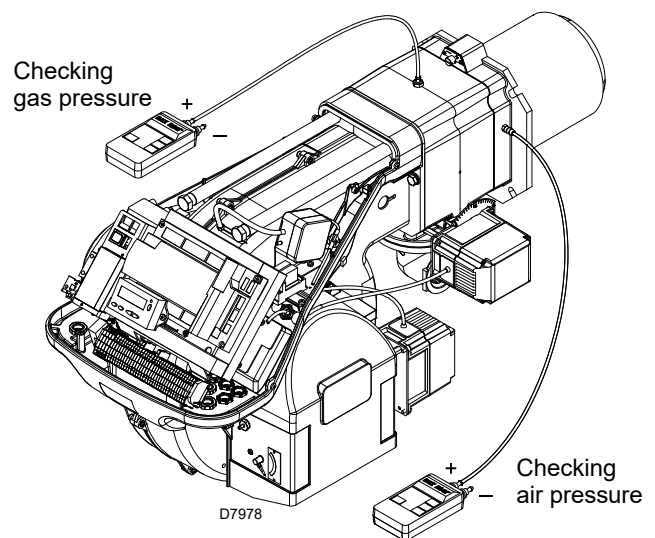

Fig. 36

6.3 Opening the burner



Disconnect the electrical supply from the burner by means of the main system switch.



Close the fuel interception tap.



Wait for the components in contact with heat sources to cool down completely.

- Loosen the 4 screws 1)(Fig. 37) and remove the hood 2).
- Assemble the two extensions supplied on the guides 4) (versions TL).
- Disconnect the plug 7) and loosen the cable grommet 8);
- Disconnect the socket from the maximum gas pressure switch;
- Remove the screws 3) and pull back the burner on the guides 4) by about 100 mm.
- Disconnect the cables of the probe and electrode, then pull the burner back completely.

At this point it is possible to extract the inner part 5) after having removed the screw 6).

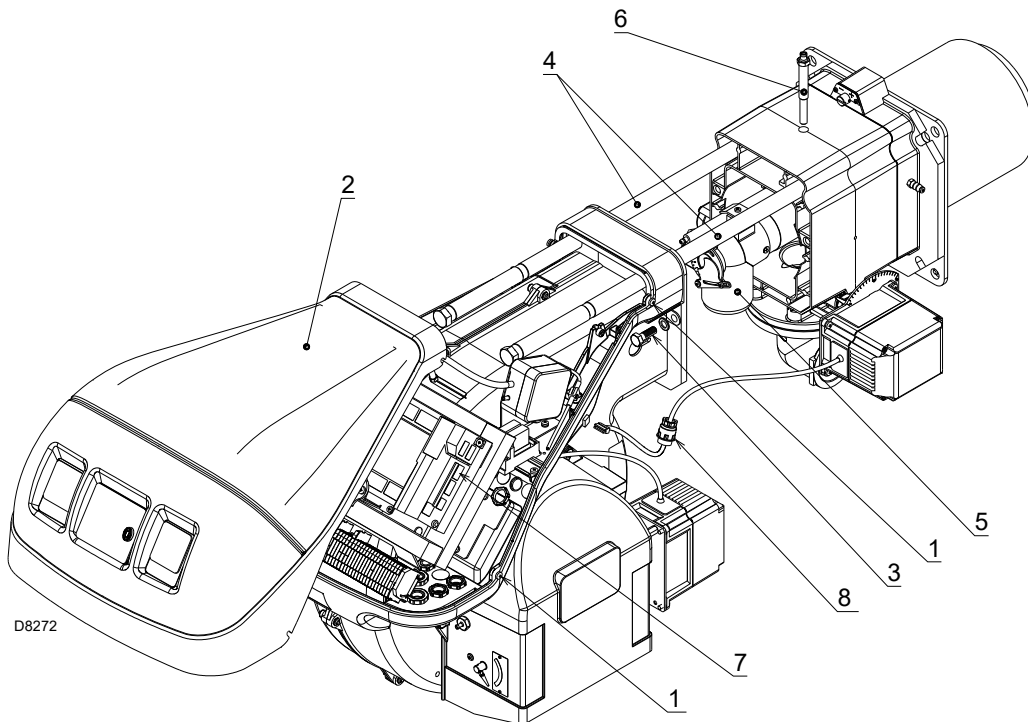

Fig. 37

6.4 Closing the burner

- Push the burner up to approximately 100 mm from the pipe coupling.
- Reinsert the cables and slide the burner as far as the stop.
- Connect the plug of the servomotor 7) and tighten the grommet 8).
- Connect the socket of the maximum gas pressure switch.
- Replace the screws 3) and carefully pull the probe and electrode cables outwards until they are slightly taut.
- Disassemble the two extensions from the guides 4).



After carrying out maintenance, cleaning or checking operations, reassemble the hood and all the safety and protection devices of the burner.

7 Faults - Probable causes - Solutions

If faults arise in ignition or operations, the burner performs a "safety stop", which is signalled by the red burner lockout LED. The display of the operator panel visualises alternately the lock-out code and the relative diagnostic. To restore start-up conditions, refer to the Reset procedure. When the burner starts up again, the red LED goes out.



In the event of a burner lockout, more than two consecutive burner reset operations could cause damage to the installation. On the third lockout, contact the Aftersales Service.



If further lockouts or burner faults occur, interventions must only be made by qualified, authorised personnel (as indicated in this manual, and in compliance with the laws and regulations currently in force).

7.1 Error codes list

Error code	Diagnostic code	Meaning of the REC 27.100A2 system	Recommended measures
No Comm		No communication between REC 37.400A2 and RDI21...	Check the wiring between the flame control REC 37.400A2 and display RDI21...
2	#	No flame at the end of TSA1	
	1	No flame at the end of safety time 1 (TSA1)	
	2	No flame at the end of safety time 2 (TSA2)	
	4	No flame at the end of safety time 1 (TSA1) (software version ≤ V02.00)	
3	#	Air pressure error	
	0	Air pressure switch off	
	1	Air pressure switch on	
	4	Air pressure on – Lockout alarm at start	
	20	Air pressure, fuel pressure on - Alarm lock at start	
	68	Air pressure, POC on – Alarm lockout at start	
	84	Air pressure, fuel pressure, POC on - Alarm lockout at start	
4	#	Extraneous light	
	0	Extraneous light during start-up	
	1	Extraneous light during switch-off	
	2	Extraneous light during start-up – Lockout alarm at start	
	6	Extraneous light during start-up, air pressure - Alarm lockout at start	
	18	Extraneous light during start-up, fuel pressure - Alarm lockout at start	
	24	Extraneous light during start-up, air pressure, fuel pressure - Alarm lockout at start	
	66	Extraneous light during start-up, POC – Alarm lockout at start	
	70	Extraneous light during start-up, air pressure, POC - Alarm lockout at start	
	82	Extraneous light during start-up, fuel pressure, POC - Alarm lockout at start	
	86	Extraneous light during start-up, air pressure, fuel pressure, poc - Alarm lockout at start	
7	#	Loss of flame	
	0	Loss of flame	
	3	Flame loss (software version ≤ V02.00)	
	3...255	Flame loss during TÜV test (flame loss test)	The diagnostics covers the period between the closure of the fuel valve to the point the flame loss is detected (resolution 0.2 s → value 5 = 1 s).
12	#	Valve leak detection control	
	0	V1 leaks	<u>Leak test</u> Check if the valve on the side of the gas has any leaks. Check the wiring and make sure that the circuit is open.
	1	V2 leaks	<u>Leak test</u> Check if the valve on the side of the burner has any leaks. Check if the pressure switch for the leak test (PGVP) is closed when gas pressure is not present. Check the wiring and check if there is a short circuit.

Error code	Diagnostic code	Meaning of the REC 27.100A2 system	Recommended measures
	2	Valve leak detection test not possible	The valve leak detection is active, but the minimum gas pressure switch is selected as input for X9-04 (check parameters 238 and 241)
	3	Valve leak detection test not possible	The valve leak detection is active, but no input has been assigned (check parameters 236 and 237)
	4	Valve leak detection not possible	Valve leak detection is active, but 2 inputs have already been assigned (configure parameter 237 or maximum gas Pressure switch or POC)
	5	Valve leak detection not possible	The valve leak detection is active, but 2 inputs have been assigned (check parameters 236 and 237)
14	#	POC	
	0	POC Open	Check if the closure contact of the valve is closed
	1	POC Closed	Check the wiring Check if the closure contact of the valve opens when the valve is checked
	64	POC Open - Alarm lockout at start	Check the wiring Check if the closure contact of the valve is closed
19	80	Fuel pressure, POC - Alarm lockout at start	Check that the pressure switch is closed when no pressure is present from the fuel Check that there are no short-circuits
20	#	Pmin	
	0	Minimum gas/oil pressure absent	Check that there are no line interruptions
	1	Scarcity of gas - Alarm lockout at start	Check that there are no line interruptions
21	#	Pmax/POC	
	0	Pmax: Max. gas/oil pressure exceeded POC: POC open (software version ≤ V02.00)	Check the wiring. POC: check whether the closure contact of the valve is closed
	1	POC closed (software version ≤ V02.00)	Check the wiring. Check if the closure contact of the valve opens when the valve is checked
	64	POC Open - Lockout alarm at the start (software version ≤ V02.00)	Check the wiring. Check if the contact of the valve opens when the valve is checked
22 OFF S	#	Safety circuit/Burner flange	
	0	Safety circuit open /Burner flange open	
	1	Safety circuit open /Burner flange open - Alarm lockout at start	
	3	Safety circuit open /Burner flange open, extraneous light - Alarm lockout at start	
	5	Safety circuit open /Burner flange open, extraneous light - Alarm lockout at start	
	17	Safety circuit open /Burner flange open, extraneous light - Alarm lockout at start	
	19	Safety circuit open /Burner flange open, extraneous light - Alarm lockout at start	
	21	Safety circuit open /Burner flange open, extraneous light - Alarm lockout at start	
	23	Safety circuit open /Burner flange open, extraneous light, air pressure, fuel pressure - Alarm lockout at start	
	65	Safety circuit /Burner flange open, POC - Alarm lockout at start	
	67	Safety circuit open /Burner flange open, extraneous light, POC - Alarm lockout at start	
	69	Safety circuit open /Burner flange open, air pressure, POC - Alarm lockout at start	
	71	Safety circuit open /Burner flange open, extraneous light, air pressure, POC - Alarm lockout at start	
	81	Safety circuit open /Burner flange open, fuel pressure, POC - Alarm lockout at start	
	83	Safety circuit open /Burner flange open, extraneous light, air pressure, POC - Alarm lockout at start	
	85	Safety circuit open /Burner flange, air pressure, fuel pressure, POC - Alarm lockout at start	
	87	Safety circuit open /Burner flange, extraneous light, air pressure, fuel pressure, POC - Alarm lockout at start	
50 ÷ 58	#	Internal error	Carry out a reset; if the error arises repeatedly, replace the flame control

Error code	Diagnostic code	Meaning of the REC 27.100A2 system	Recommended measures
60	0	Internal error: no valid load checking device	Carry out a reset; if the error arises repeatedly, replace the flame control
65 ÷ 67	#	Internal error	Carry out a reset; if the error arises repeatedly, replace the flame control
70	#	Fuel/air checking error: Calculation position in modulation	
	23	Invalid load	No valid load
	26	Curve points not defined	Adjust the curve points of all the actuators
71	#	Special position not defined	
	0	Standby position	Set the standby position of all the servomotors used
	1	Pre-purging position	Set the pre-purging position of all the servomotors used
	2	Post-purging position	Set the post-purging position of all the servomotors used
	3	Ignition position	Set the ignition position of all the servomotors used
72	#	Fuel/air internal checking error:	Carry out a reset; if the error arises repeatedly, replace the flame control
73	#	Fuel/air internal checking error: multistep calculation position	
	23	Position calculation, invalid stage load	No valid load
	26	Position calculation, stage curve points not defined	Adjust the curve points of all the servomotors
75	#	Fuel/air ratio internal checking error: cyclical data check	
	1	Check synchronisation data, different current load	
	2	Check synchronisation data, different target load	
	4	Check synchronisation data, different target positions	
	16	Check synchronisation data, different positions reached	May be caused by different standardisation speeds (for example following the resetting of the data set) when the VSD is active -> perform the standardisation again and check the regulation of the fuel/air ratio.
76	#	Fuel/air internal checking error:	Carry out a reset; if the error arises repeatedly, replace the flame control
80	#	VSD control range limit	<p>The standard unit could not correct the speed difference and has reached a limit in the control range.</p> <p>1. The base unit is not standardised for this motor ----> repeat the standardisation.</p> <p>WARNING! check the settings of the air/fuel ratio control!</p> <p>2. The VSD train times are not shorter than those of the standard unit (parameters 522, 523).</p> <p>3. The VSD characteristic is not linear. The VSD voltage input configuration must correspond with that of the standard unit (parameter 645).</p> <p>4. The VSD does not follow the changes of the standard unit quickly enough. Check the VSD settings (input filter, slide compensation, different latent speeds).</p>
	1	Lower control range limit	The VSD speed was too high
	2	Upper control range limit	The VSD speed was too low
81	1	Interruption in speed limit input	Excessive electromagnetic interference on the sensor line -> improve the EMC
82	#	Error during VSD speed standardisation	
	1	Standardisation time-out (the descent time of the VSD train is too long)	Time-out at the end of the standardisation, during deceleration of VSD 1. The VSD train times are not shorter than those of the standard unit (parameter: 523)
	2	Logging of the standardised speed not successful	Error during the logging of the standardised speed ----> block the standard unit, reset it and repeat the standardisation
	3	Speed sensor circuit open	The standard unit does not receive pulses from the speed sensor: 1. The motor does not rotate. 2. The speed sensor is not connected. 3. The speed sensor is not activated by the sensor disc (check the distance)

Error code	Diagnostic code	Meaning of the REC 27.100A2 system	Recommended measures
	4	Variation in speed / VSD acceleration time too long / speed below the minimum limit for standardisation	<p>The motor has not reached a stable speed after acceleration.</p> <ol style="list-style-type: none"> The VSD train times are not shorter than those of the standard unit (parameters 522, 523). The VSD characteristic is not linear. The VSD voltage input configuration must correspond with that of the standard unit (parameter 645). The VSD does not follow the changes of the standard unit quickly enough. Check the VSD settings (input filter, slide compensation, different latent speeds). The VSD speed is below the minimum for standardisation (650 rpm).
	5	Incorrect rotation direction	<p>The motor rotation direction is incorrect.</p> <ol style="list-style-type: none"> The motor does not rotate in the correct direction ----> modify the parameterisation of the rotation direction, or invert 2 phases. The sensor disc is incorrectly assembled ----> turn the sensor disc.
	6	Implausible speed sensor signals	<p>The required pulse pattern (60°, 120°, 180°) has not been correctly identified.</p> <ol style="list-style-type: none"> The speed sensor does not detect all the noses of the sensor disc ----> check the distance When the motor rotates, other metal parts are detected along with the noses ----> improve the assembly. Electromagnetic interference on the sensor lines ----> check the cable path, improve the EMC
	7	Standardised speed not valid	<p>The standardised speed measured is not within the allowed range.</p> <ol style="list-style-type: none"> The motor turns too slowly or too quickly.
	15	Speed deviation $\mu C1 + \mu C2$	<p>Microcomputer speeds 1 and 2 have an excessive deviation. This may be caused by incorrect standardised speeds (e.g. after the reintegration of a set of data in a new unit) ----> repeat the standardisation and check the air/fuel ratio.</p>
	20	Incorrect phase of the phase controller	<p>The standardisation was performed in the wrong phase. The only phases allowed are ≤ 12 ----> controller OFF, restart the standardisation.</p>
	21	Safety loop/burner flange open	<p>The safety loop or burner flange is open ----> repeat the standardisation with the safety loop closed</p>
	22	Pneumatic actuator without reference	<p>The air actuator has no reference, or has lost it.</p> <ol style="list-style-type: none"> Check whether the reference position can be approached. Check whether the actuators have been swapped over. If the error only arises after the start of standardisation, the actuator may be overloaded and unable to reach its destination.
	23	VSD deactivated	<p>The standardisation was started with the VSD deactivated ----> activate the VSD and repeat the standardisation</p>
	24	No valid operation mode	<p>The standardisation was started without a valid operation mode ----> activate a valid operation mode and repeat the standardisation</p>
	25	Pneumatic control of the air/fuel ratio	<p>The standardisation was started with a pneumatic control of the air/fuel ratio ----> it is not possible to carry out the standardisation with a pneumatic control of the air/fuel ratio</p>
	128	Run command without prior standardisation	<p>The VSD is controlled but not standardised ----> perform the standardisation</p>
	255	No standardised speed available	<p>The motor turns but is not standardised ----> perform the standardisation</p>
83	#	VSD speed error	The required speed has not been reached
	Bit 0 Valence 1	Lower control range limit	<p>The speed was not reached because the control range limit was activated ----> for the measurements, see error code 80</p>
	Bit 1 Valence 2...3	Greater control range limit	<p>The speed was not reached because the control range limit was activated ----> for the measurements, see error code 80</p>
	Bit 2 Valence 4...7	Stop caused by electromagnetic interference	<p>The speed has not been reached because there are too many electromagnetic interferences on the sensor line. For the measurements, see error code 81.</p>

Error code	Diagnostic code	Meaning of the REC 27.100A2 system	Recommended measures
	Bit 3 Valence ≥ 8	Curve too steep in terms of train speed	The speed was not reached because the curve was too steep. 1. With a train REC3... of 20 s, the speed variation between 2 points of the curve (in modulating mode) cannot exceed 10%. With a train REC3... of 10 s, the speed variation between 2 points of the curve (in modulating mode) cannot exceed 20%. With a train REC3... of 5 s, the speed variation between 2 points of the curve (in modulating mode) cannot exceed 40%. ---> Between the ignition point (P0) and the low flame point (P1), the speed in modulating mode may vary by a maximum of 40%, regardless of the train REC3.... 2. The VSD train must be about 20% faster than the train of the standard unit (parameters 522, 523).
	Bit 4 Valence ≥ 16	Speed signal interruption	No speed detected, despite the control. 1. Check the motor is rotating. 2. Check whether the speed sensor provides a signal (LED / check the distance from the sensor disc). 3. Check the VSD wiring.
	Bit 5 Valence ≥ 32	Quick switch-off due to excessive speed deviation	For about 1 s, the speed deviation was >10% outside the envisaged range. 1. Check the train times of REC3.... and VSD. 2. Check the VSD wiring.
84	#	Servomotors curve slope	
	Bit 0 Valence ≥ 1	VSD: Curve too steep in terms of train speed	1. With a train REC3... of 20 s, the speed variation between points of the curve (in modulating mode) cannot exceed 10%. With a train REC3... of 10 s, the speed variation between points of the curve (in modulating mode) cannot exceed 20%. 2. With a train REC3... of 5 s, the speed variation between points of the curve (in modulating mode) cannot exceed 40%. ---> Between the ignition point (P0) and the low flame point (P1), the speed in modulating mode may vary by a maximum of 40%, regardless of the train REC3.... The VSD train must be about 20% faster than the train of the standard unit (parameters 522, 523)
	Bit 1 Valence 2..3	Fuel servomotor: Curve too steep in terms of train ratio	The slope of the curve can correspond to a maximum position variation of 31° between 2 points of the modulation curve
	Bit 2 Valence 4..7	Air servomotor: Curve too steep in terms of train ratio	The slope of the curve can correspond to a maximum position variation of 31° between 2 points of the modulation curve
85	#	Reference error of a servomotor	
	0	Reference error of the fuel servomotor	The reference of the fuel servomotor was not successful. It was not possible to reach the reference point. 1. Check if the servomotors have been inverted. 2. Check if the servomotor is blocked or overloaded.
	1	Reference error of the air servomotor	The reference of the air servomotor was not successful. It was not possible to reach the reference point. 1. Check if the servomotors have been inverted. 2. Check if the servomotor is blocked or overloaded.
	Bit 7 Valence ≥ 128	Reference error owing to parameter modification	The parameterisation of an actuator (e.g. the reference position) has been modified. This error will be visualised to start up a new reference.
86	#	Fuel servomotor error	
	0	Position error	It was not possible to reach the target position within the required range ---> Check to see if the servomotor is blocked or overloaded.
	Bit 0 Valence 1	Circuit open	Open circuit detected on the connection of the servomotor ---> Check the wiring (voltage between pins 5 or 6 and 2 of the X54 connector should be > 0.5 V).
	Bit 3 Valence ≥ 8	Curve too steep in terms of train ratio	The slope of the curve can correspond to a maximum position modification of 31° between 2 points of the modulation curve.
	Bit 4 Valence ≥ 16	Deviation of section compared with the last reference	Overloading of the servomotor or servomotor subjected to mechanical torsion. 1. Check if the servomotor is blocked in any point along its range of action. 2. Check if the torque is sufficient for the application.
87	#	Air servomotor error	
	0	Position error	It was not possible to reach the target position within the requested tolerance range. 1. Check if the servomotor is blocked or overloaded.
	Bit 0 Valence 1	Circuit open	Open circuit detected on the connection of the servomotor ---> Check the wiring (voltage between pins 5 or 6 and 2 of the X54 connector should be > 0.5 V).
	Bit 3 Valence ≥ 8	Curve too steep in terms of train ratio	The slope of the curve can correspond to a maximum position modification of 31° between 2 points of the modulation curve.

Error code	Diagnostic code	Meaning of the REC 27.100A2 system	Recommended measures
	Bit 4 Valence ≥ 16	Deviation of section compared with the last reference	Overloading of the servomotor or servomotor subjected to mechanical torsion. 1. Check if the servomotor is blocked in any point along its range of action. 2. Check if the torque is sufficient for the application.
90 - 91	#	Burner internal checking error	
93	#	Flame signal acquisition error	
	3	Short circuit of the sensor	Short circuit in the QRB sensor... 1. Check the wiring. 2. Flame detector probably faulty.
95	#	Relay supervision error	
	3 Ignition transformers 4 Fuel valve 1 5 Fuel valve 2 6 Fuel valve 3	External power supply - Contact active	Check the wiring
96	#	Relay supervision error	
	3 Ignition transformers 4 Fuel valve 1 5 Fuel valve 2 6 Fuel valve 3	The relay contacts have joined together	Check the contacts: 1. Flame control connected to the power supply: the fan output must be without voltage. 2. Disconnect the power supply. Disconnect the fan. The resistive connection between the fan output and the neutral wire is not allowed. If one of the 2 tests fails, replace the flame control because the contacts are definitively joined together and it is no longer possible to guarantee safety.
97	#	Relay supervision error	
	0	The safety relay contacts have joined together or the safety relay has been powered by an external power supply	Check the contacts: 1. Flame control connected to the power supply: the fan output must be without voltage. 2. Disconnect the power supply. Disconnect the fan. The resistive connection between the fan output and the neutral wire is not allowed. If one of the 2 tests fails, replace the flame control because the contacts are definitively joined together and it is no longer possible to guarantee safety.
98	#	Relay supervision error	
	2 - Safety valve 3 Ignition transformers 4 Fuel valve 1 5 Fuel valve 2 6 Fuel valve 3	The relay does not start up	Carry out a reset; if the error arises repeatedly, replace the unit
99	#	Relay internal checking error	Carry out a reset; if the error arises repeatedly, replace the flame control
	3	Relay internal checking error	Carry out a reset; if the error arises repeatedly, replace the flame control Software version V03.10: If error C:99 D:3 occurs during the standardisation of the VSD, temporarily deactivate the Alarm function at the start of the pre-purging phase (parameter 210 = 0) or interrupt the signal controller-ON
100	#	Relay internal checking error	Carry out a reset; if the error arises repeatedly, replace the flame control
105	#	Contact sampling internal error	
	0 Min. pressure switch 1 Max. pressure switch 2 Valve operation test pressure switch 3 Air pressure 4 Load controller open 5 Load controller on/off 6 Load controller closed 7 Safety loop / burner flange 8 Safety valve 9 Ignition transformers 10 Fuel valve 1 11 Fuel valve 2 12 Fuel valve 3 13 Reset	Blocked upon irregularity	Can be caused by capacitive loads or presence of DC voltage on the main power supply of the flame control. The diagnostic code indicates the input in which the problem arose
106 ÷ 108	#	Contact request internal error	Carry out a reset; if the error arises repeatedly, replace the flame control
110	#	Voltage monitoring test internal error	Carry out a reset; if the error arises repeatedly, replace the flame control

Error code	Diagnostic code	Meaning of the REC 27.100A2 system	Recommended measures
111	0	Low level of power supply	Insufficient mains voltage. Conversion of the diagnostic code ---> Voltage value (230 V AC : 1,683)
112	0	Reset power supply voltage	Error code for the carrying out of a reset in the event of power supply restoration (absence of error)
113	#	Mains voltage supervision internal error	Carry out a reset; if the error arises repeatedly, replace the flame control
115	#	Flame control meter internal error	
116	0	Life cycle of the flame control in the critical interval (250,000 Start ups)	The envisaged life cycle of the flame control has been exceeded. Replace it.
117	0	Life cycle of the flame control exceeded	The switch-off threshold has been reached.
120	0	Interruption of fuel limiting meter input	Too many disturbance impulses on the input of the fuel meter - --> Improve the electromagnetic compatibility.
121 ÷ 124	#	EEPROM access internal error	Carry out a reset, repeat and check the last setting of the parameters. Restore the group of parameters: if the error arises repeatedly, replace the flame control.
125	#	EEPROM reading access internal error	Carry out a reset, repeat and check the last setting of the parameters. If the error arises repeatedly, replace the flame control.
126	#	EEPROM writing access internal error	Carry out a reset, repeat and check the last setting of the parameters. If the error arises repeatedly, replace the flame control.
127	#	EEPROM access internal error	Carry out a reset, repeat and check the last setting of the parameters. Restore the group of parameters: if the error arises repeatedly, replace the flame control.
128	0	EEPROM access internal error - synchronisation during the initialisation	Carry out a reset; If the error arises repeatedly, replace the flame control.
129	#	EEPROM access internal error – command synchronisation	Carry out a reset, repeat and check the last setting of the parameters. If the error arises repeatedly, replace the flame control.
130	#	EEPROM access internal error - time-out	Carry out a reset, repeat and check the last setting of the parameters. If the error arises repeatedly, replace the flame control.
131	#	EEPROM access internal error - page interrupted	Carry out a reset, repeat and check the last setting of the parameters. If the error arises repeatedly, replace the flame control.
132	#	EEPROM register initialisation internal error	Carry out a reset; If the error arises repeatedly, replace the flame control.
133 ÷ 135	#	EEPROM access internal error – request synchronisation	Carry out a reset, repeat and check the last setting of the parameters. If the error arises repeatedly, replace the flame control.
136	1	Restoration started	The restoration of a backup has been started (no error)
137	#	Internal error – backup / restoration	
	157 (-99)	Restoration – OK, but backup < compared with set data of current system	Restoration successful, but the backup data installed are fewer than those currently present in the system.
	239 (-17)	Backup - logging of the backup on RDI21... failed	Perform the reset and repeat backup
	240 (-16)	Reset - no backup in RDI21...	No backup in RDI21...
	241 (-15)	Reset - Interruptions relating to impracticable ASN	The backup has an impracticable ASN and cannot reset the unit
	242 (-14)	Backup – the backup carried out is contradictory	The backup is irregular and cannot be transferred again
	243 (-13)	Backup – the data comparison between the internal microprocessors is irregular	Repeat the reset and backup
	244 (-12)	The backup data are incompatible	The backup data are incompatible with the current version of the software; the restoration is not possible
	245 (-11)	Error in access to the parameter Restore_Complete	Repeat the reset and backup
	246 (-10)	Restoration – time-out during logging in EEPROM	Repeat the reset and backup
	247 (-9)	The data received are contradictory	The series of backup data is not valid; restoration is not possible
	248 (-8)	The restoration cannot currently be carried out	Repeat the reset and backup
	249 (-7)	Restoration – interruption caused by inadequate identification of the burner	The backup has an inadequate identification of the burner and must not be transferred to the flame control.
	250 (-6)	Backup – the CRC of a page is not correct	The series of backup data is not valid; restoration is not possible
	251 (-5)	Backup – the identification of the burner is not defined	Define the identification of the burner and repeat the backup
	252 (-4)	After restoration, the pages are still in INTERRUPTION	Repeat the reset and backup
	253 (-3)	The restoration cannot currently be carried out	Repeat the reset and backup

Error code	Diagnostic code	Meaning of the REC 27.100A2 system	Recommended measures
	254 (-2)	Interruption owing to transmission error	Repeat the reset and backup
	255 (-1)	Interruption owing to time-out during the restoration	Carry out a reset, check the connections and repeat the backup
146	#	Time-out of the system automation interface	Refer to the Modbus User Documentation (A7541)
	1	Modbus time-out	
150	#	TÜV test	
	1 (-1)	Invalid phase	The TÜV test can only be started in phase 60 (operation)
	2 (-2)	The TÜV test default output is too low	The output of the TÜV test must be lower than the minor output limit
	3 (-3)	The TÜV test default output is too high	The output of the TÜV test must be greater than the upper output limit
	4 (-4)	Manual interruption	No error: Manual interruption of the TÜV test by the user
	5 (-5)	TÜV test timeout	No flame loss after the fuel valves have been closed 1. Check for potential extraneous lights 2. Check that there are no short-circuits 3. Check that one of the valves is leaking
165	#	Internal error	
166	0	Watchdog reset internal error	
167	#	Manual lockout	The flame control has been manually blocked (no error)
	1	Manual lockout from remote reset command	
	2	Manual lockout from RDI21...	
	3	Manual lockout from PC interface	
	8	Manual lockout from RDI21... Timeout/interrupted communication	During a regulation of the curve via the operating panel RDI21...the timeout for the operating menu is passed (setting via the 127 parameter), or else the communication between REC 37.400A2 and RDI21... has been interrupted
	9	Manual lockout from PC interface Communication interrupted	During an adjustment of the curve via the PC interface, the communication between REC 37.400A2 and the operator panel has been interrupted for more than 30 seconds
	33	Manual lockout after the PC tool has performed a tentative reset	The PC tool has performed a tentative reset, even if the system has worked correctly
168 ÷ 171	#	Internal error management	Carry out a reset; if the error arises repeatedly, replace the flame control.
200 OFF	#	System free of errors	No error
201 OFF UPr	#	Lockout or error at start	Lockout or error due to lack of unit parameter settings
	Bit 0 Valency 1	No valid operation mode	
	Bit 1 Valency 2..3	No fuel train defined	
	Bit 2 Valency 4..7	No curve defined	
	Bit 3 Valency 8..15	Standardisation speed not defined	
	Bit 4 Valency 16..31	Backup / Reset impossible	
202	#	Selection of internal operation mode	Redefine the operation mode (parameter 201)
203	#	Internal error	Redefine the operation mode (parameter 201) Carry out a reset; if the error arises repeatedly, replace the flame control.
204	Phase number	Program stop	The program stop is active (no error)
205	#	Internal error	Carry out a reset; if the error arises repeatedly, replace the flame control.
206	0	Combination of flame control and operator panel not allowed	
207	#	Compatibility of flame control with operator panel	
	0	Obsolete version of flame control	
	1	Obsolete version of operator panel	
208 - 209	#	Internal error	Carry out a reset; if the error arises repeatedly, replace the flame control.
210	0	The selected operating mode is not released for the standard unit	Select an operating mode released for the standard unit
240	#	Internal error	Carry out a reset; if the error arises repeatedly, replace the flame control.
245	#	Internal error	Carry out a reset; if the error arises repeatedly, replace the flame control.

Error code	Diagnostic code	Meaning of the REC 27.100A2 system	Recommended measures
250	#	Internal error	Carry out a reset; if the error arises repeatedly, replace the flame control.

Tab. R

A Appendix - Accessories**Output power regulator kit for modulating operation**

With the modulating operation, the burner continually adapts the power to the request for heat, ensuring great stability for the parameter controlled: temperature or pressure.

Two components should be ordered:

- the output regulator to install on the burner;
- the probe to install on the heat generator.

Parameter to be checked		Probe		Output regulator	
	Adjustment field	Type	Code	Type	Code
Temperatur	- 100 ÷ 500° C	PT 100	3010110	RWF50 RWF55	20099869 20099905
Pressure	0 ÷ 2,5 bar	4 ÷ 20 mA	3010213		
	0 ÷ 16 bar	4 ÷ 20 mA	3010214		
	0 ÷ 25 bar	4 ÷ 20 mA	3090873		

Long head kit

Bruciatore	Kit code	Standard head length	Head length obtained with the kit
RS 190/EV	3010443	372 mm	530 mm

Kit for LPG operation

Burner	Code	Power (kW)
RS 190/EV	3010166	465 ÷ 2290 kW

Modbus interface Kit (OCI412)

Burner	Code
RS 190/EV	3010437

Soundproofing chamber

Burner	Code
RS 190/EV	3010404

Continuous purging kit

Burner	Code
RS 190/EV	3010094

Gas trains in compliance with EN 676

Please refer to manual.

Pipes Kit (for flame inversion boilers)

Burner	Code
RS 190/EV	3010375

Kit for TOWN GAS operation - not CE type-approved

Burner	Code
RS 190/EV	3010297

Software interface Kit (ACS410 + OCI410.30) - Service Level



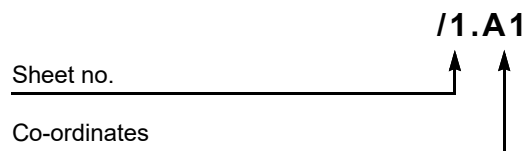

Burner	Code
RS 190/EV	3010436

B Appendix - Electrical panel layout

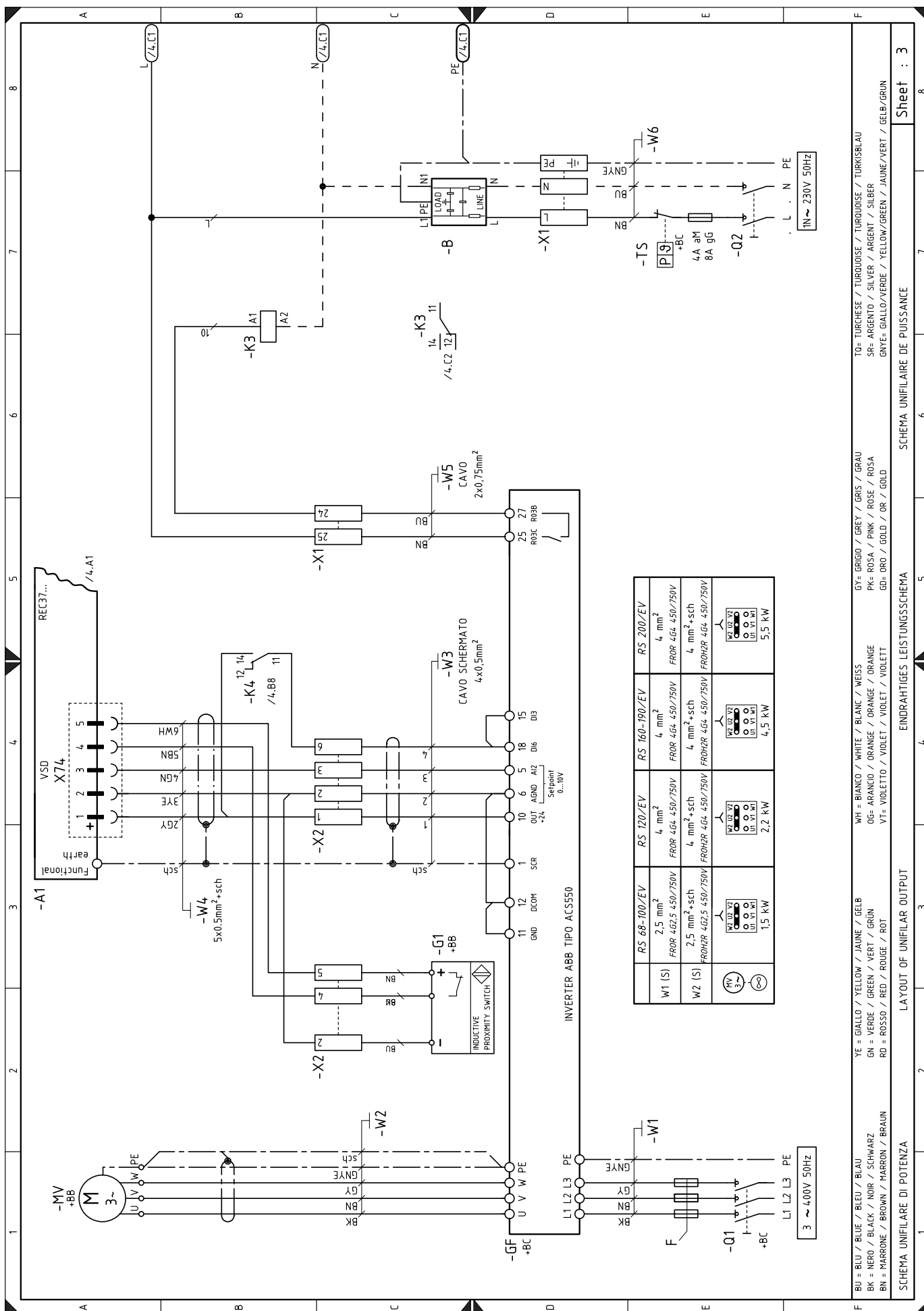
1	Index of layouts
2	Indication of references
3	Layout of unifilar output
4	REC37... operational layout
5	REC37... operational layout
6	REC37... operational layout
7	Electrical connections set by installer
8	Operational layout RWF50...

2 Indication of references



	RS 68-100/EV	RS 120/EV	RS 160-190/EV	RS 200/EV
W1 (S)	2.5 mm ² FROR 4G2.5 450/750V	4 mm ² FROR 4G4 450/750V	4 mm ² FROR 4G4 450/750V	4 mm ² FROR 4G4 450/750V
W2 (S)	2.5 mm ² +sch FRORHR 4G2.5 450/750V	4 mm ² +sch FRORHR 4G4 450/750V	4 mm ² +sch FRORHR 4G4 450/750V	4 mm ² +sch FRORHR 4G4 450/750V
				
	1.5 kW	2.2 kW	4.5 kW	5.5 kW

TO= TURCHESE / TURQUOISE / TURQUOISE / TURKISBLAU
 SR= ARGENTO / SILVER / ARGENT / SILBER
 GNYE= GIALLO/VERDE / YELLOW/GREEN / JAUNE/VERT / GELB/GRÜN

GY= GRIGIO / GREY / GRIS / GRAU
 PK= ROSA / PINK / ROSE / ROSA
 GD= ORO / GOLD / OR / GOLD

WH= BIANCO / WHITE / BLANC / WEISS
 OG= ARANCIO / ORANGE / ORANGE / ORANGE
 VT= VIOLETTA / VIOLET / VIOLET / VIOLETT

YE = GIALLO / YELLOW / JAUNE / GELB
 GN = VERDE / GREEN / VERT / GRÜN
 RD = ROSSO / RED / ROUGE / ROT

BU = BLU / BLUE / BLEU / BLAU
 BK = NERO / BLACK / NOIR / SCHWARZ
 BN = MARRONE / BROWN / MARRON / BRAUN

SCHEMA UNIFILARE DI POTENZA
 LAYOUT OF UNIFILAR OUTPUT
 ENDRAHTIGES LEISTUNGSSCHEMA
 SCHEMA UNIFILAIRE DE PUISSANCE

Sheet : 3

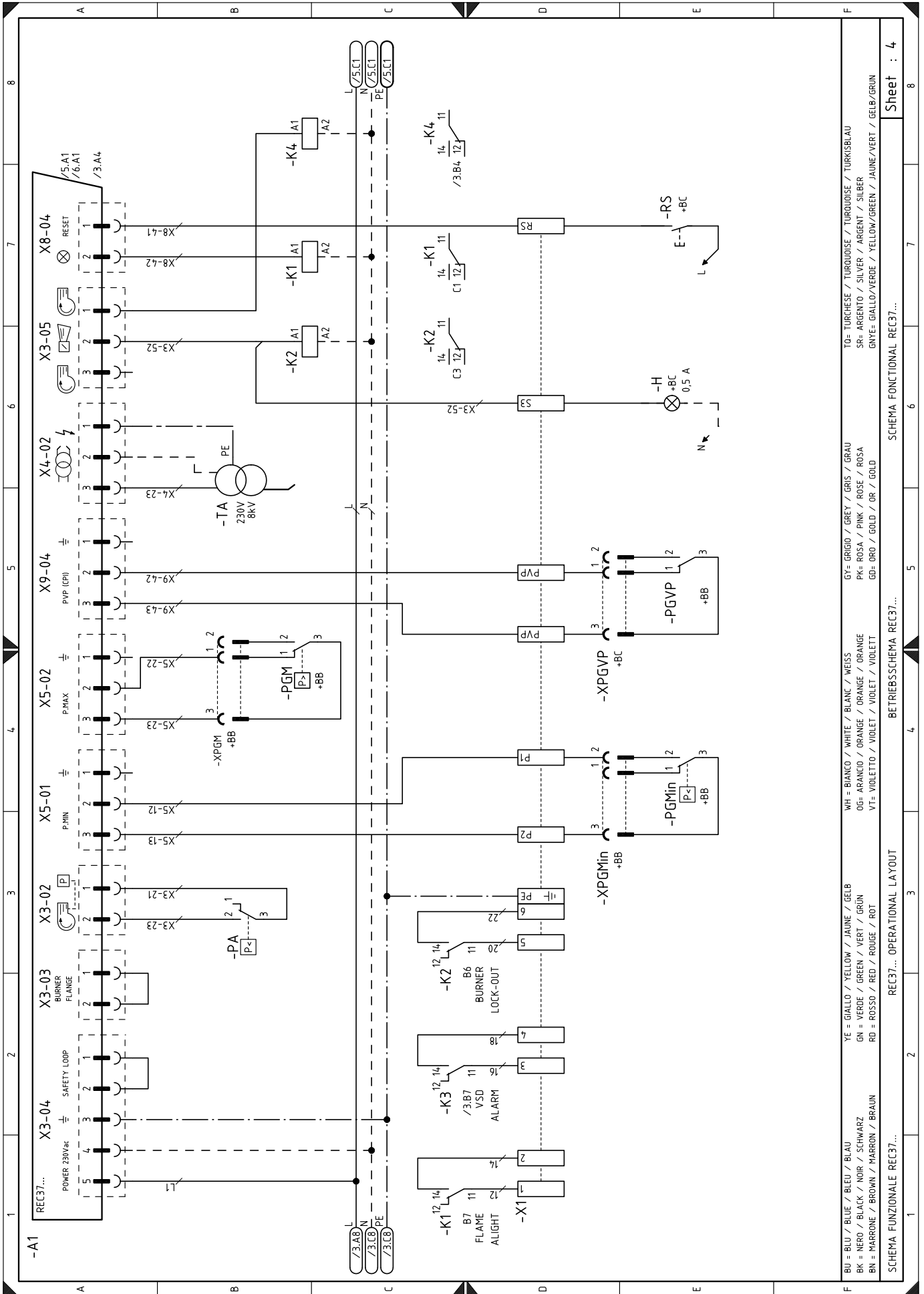

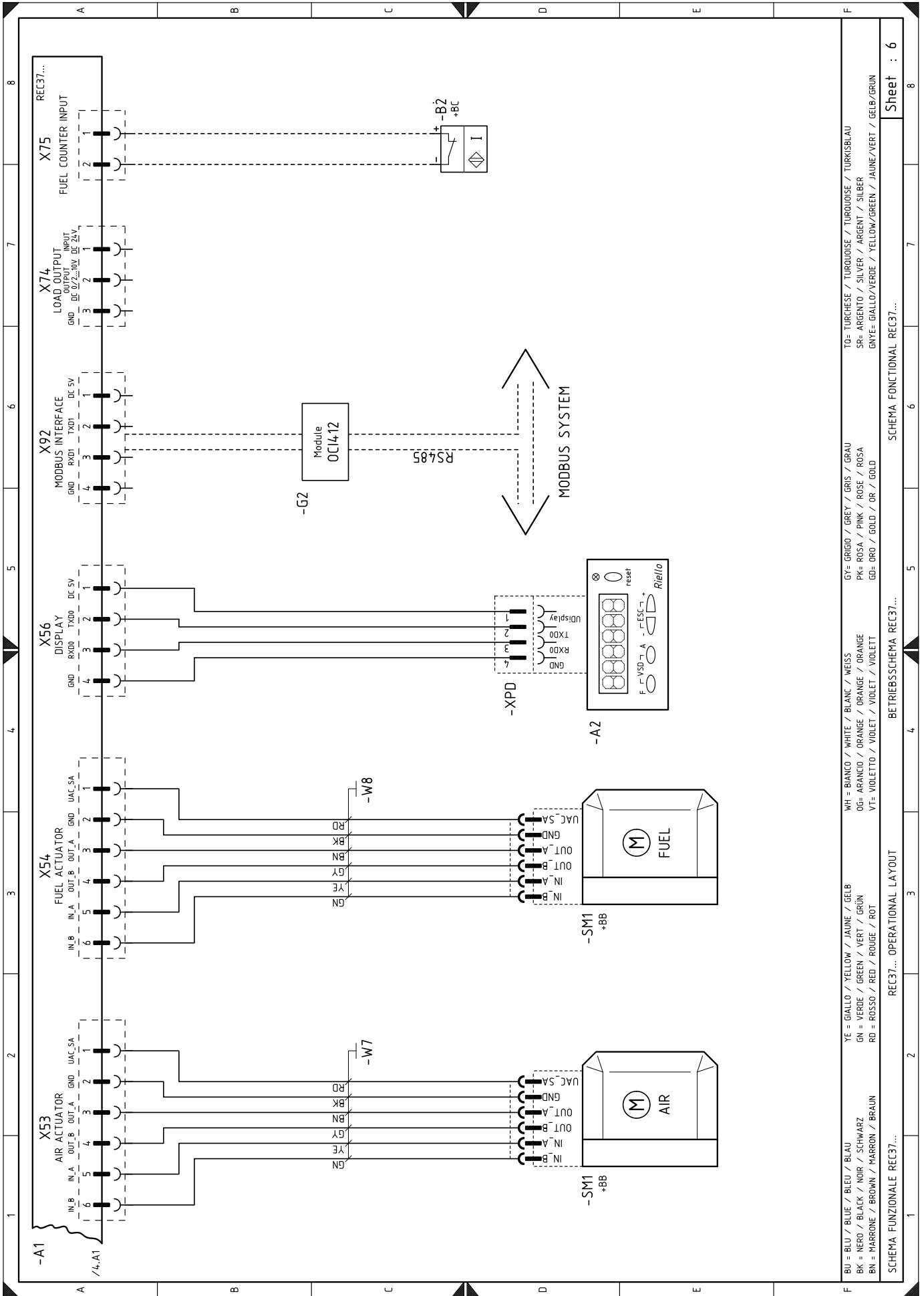

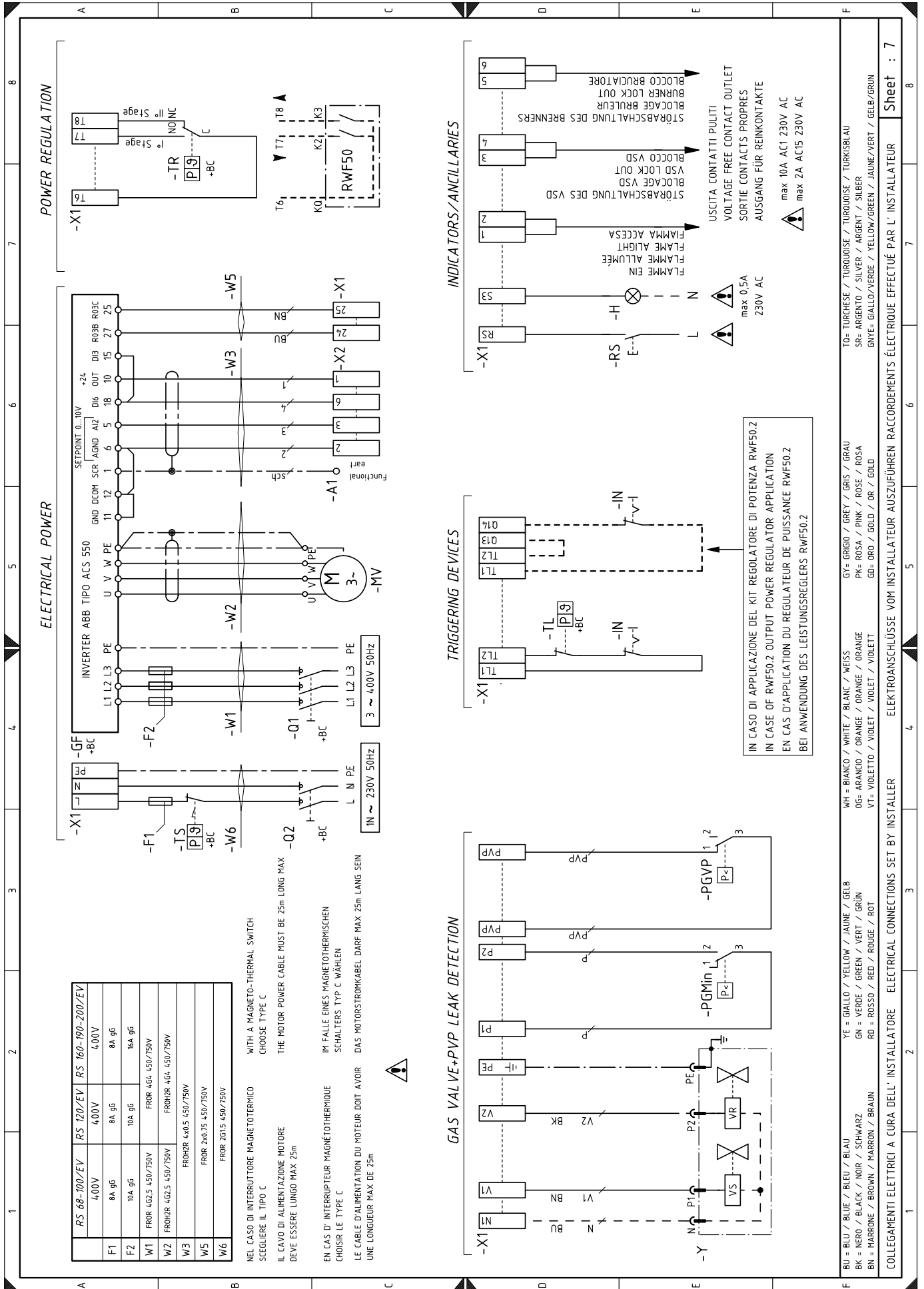

RS 68-100/EV	RS 120/EV	RS 160-190-200/EV
4.00V	4.00V	4.00V
8A gg	8A gg	8A gg
10A gg	10A gg	16A gg
FROR 4G2.5 450/750V	FROR 4G4 450/750V	FROR 4G4 450/750V
FROR 4G0.5 450/750V	FROR 4G1.5 450/750V	FROR 2G0.75 450/750V
FROR 2G1.5 450/750V		

NEL CASO DI INTERRUPTORE MAGNETOTERMICO
SCEGLIERE IL TIPO C
WITH A MAGNETO-THERMAL SWITCH
CHOOSE TYPE C
IL CAVO DI ALIMENTAZIONE MOTORE
DEVE ESSERE LUNGO MAX 25m
THE MOTOR POWER CABLE MUST BE 25m LONG MAX

EN CAS D'INTERRUPTEUR MAGNÉTHERMIQUE
CHOISIR LE TYPE C
IM FALLE EINES MAGNETOTHERMISCHEN
SCHALTERS TYP C WÄHLEN
LE CABLE D'ALIMENTATION DU MOTEUR DOIT AVOIR
UNE LONGUEUR MAX DE 25m
DAS MOTORSTROMKABEL DARF MAX 25m LANG SEIN



GAS VALVE+PVP LEAK DETECTION

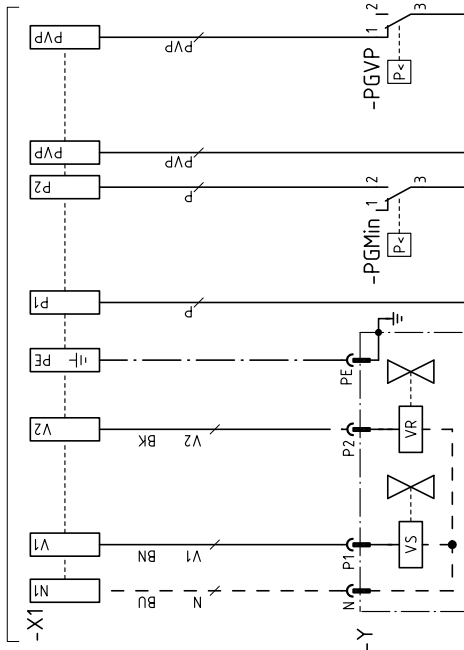

TRIGGERING DEVICES

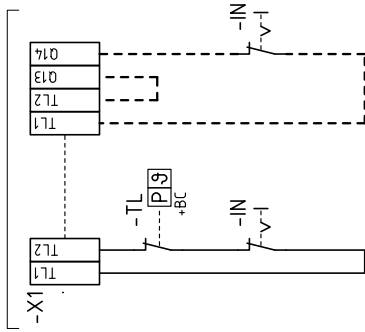

IN CASO DI APPLICAZIONE DEL KIT REGOLATORE DI POTENZA RWF50.2
IN CASE OF RWF50.2 OUTPUT POWER REGULATOR APPLICATION
EN CAS D'APPLICATION DU REGULATEUR DE PUISSANCE RWF50.2
BEI ANWENDUNG DES LEISTUNGSREGLEERS RWF50.2

INDICATORS/ANCILLARIES

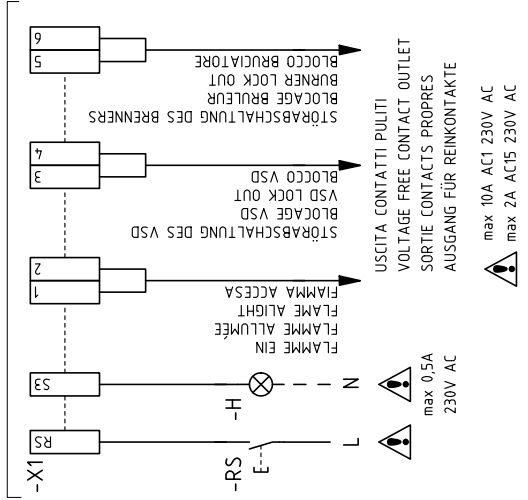

WH = BIANCO / WHITE / BLANC / WEISS
GY = GRIGIO / GREY / GRIS / GRAU
PK = ROSA / PINK / ROSE / ROSA
OG = ARANCIO / ORANGE / ORANGE / ORANGE
GD = GRG / GOLD / OR / GOLD
VT = VIOLETT / VIOLET / VIOLET / VIOLETT

YE = GIALLO / YELLOW / JAUNE / GELB
GN = VERDE / GREEN / VERT / GRÜN
RD = ROSSO / RED / ROUGE / ROT
BU = BLU / BLUE / BLEU / BLAU
BK = NERO / BLACK / NOIR / SCHWARZ
BN = MARRONE / BROWN / MARRON / BRAUN

TO= TURCHESE / TURQUOISE / TURQUOISE / TURKISBLAU
SR= ARGENTO / SILVER / ARGENT / SILBER
GNYE= GIALLO/VERDE / YELLOW/GREEN / JAUNE/VERT / GELB/GRÜN
COLLEGAMENTI ELETTRICI A CURA DELL'INSTALLATORE ELECTRICAL CONNECTIONS SET BY INSTALLER

Sheet : 7

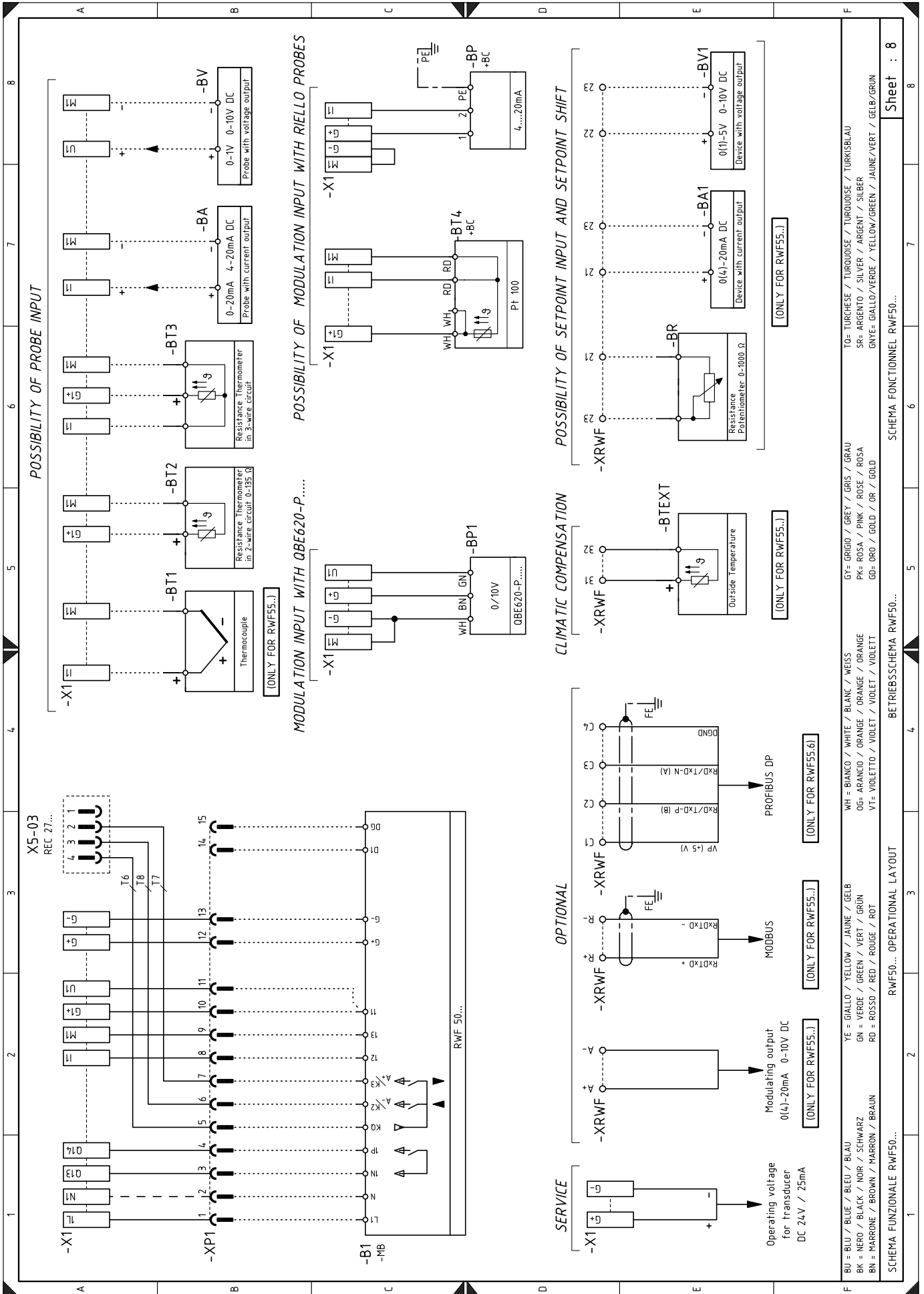

Wiring layout key

A1	Flame control for the air/fuel ratio
A2	Operator Panel
+BB	Burner components
+BC	Boiler components
B	Filter to protect against radio disturbance
B1	Output regulator RWF
B2	Fuel meter
BA	Input in current DC 4...20 mA
BA1	Input in current DC 4...20 mA to modify remote setpoint
BP	Pressure probe
BP1	Pressure probe
BR	Remote setpoint potentiometer
BT1	Thermocouple probe
BT2	Probe Pt100, 2 wires
BT3	Probe Pt100, 3 wires
BT4	Probe Pt100, 3 wires
BTEXT	External probe for climatic compensation of the setpoint
BV	Input in voltage DC 0...10V
BV1	Input in voltage DC 0...10V to modify remote setpoint
CN1	Ionisation probe connector
GF	Inverter
G1	RPM sensor
G2	Communication interface for Modbus system
H	Remote lockout signal
ION	Ionisation probe
IN	Manual burner arrest switch
K1	Clean contacts output relay burner switched on
K2	Clean contacts output relay burner lockout
K3	Clean contacts output relay inverter alarm
K4	Fan enable relay
MV	Fan motor
PA	Air pressure switch
PE	Burner earth
PGM	Maximum gas pressure switch
PGMin	Minimum gas pressure switch
PGVP	Gas pressure switch for valve leak detection control device
Q1	Three-phase disconnecting switch
Q2	Single phase disconnecting switch
RS	Remote burner reset button
S1	On/off selector
SM1	Air servomotor
SM2	Gas servomotor
TA	Ignition transformer
TL	Limit thermostat/pressure switch
TR	Adjustment thermostat/pressure switch
TS	Safety thermostat/pressure switch
X1	Burner terminal strip
X2	Terminal board for RPM sensor
XP1	Connector for output power regulator kit RWF
XPD	Operator Panel connector
XPGM	Maximum gas pressure switch connector
XPGMin	Minimum gas pressure switch connector
XPGVP	Gas pressure switch connector for valve leak detection control device
XRWF	Terminal board for output power regulator RWF
Y	Gas adjustment valve + gas safety valve

RIELLO

RIELLO S.p.A.
I-37045 Legnago (VR)
Tel.: +39.0442.630111
[http:// www.riello.it](http://www.riello.it)
[http:// www.riello.com](http://www.riello.com)