

GB **Forced draught gas burners**

Modulating operation

CE

**UK
CA**

EAC

CODE	MODEL	TYPE
20162652	RS 410/EV FGR	S029T2
20162653	RS 510/EV FGR	S030T2
20162655	RS 610/EV FGR	S031T2



Translation of the original instructions

1	Information and general warnings.....	3
1.1	Information about the instruction manual	3
1.1.1	Introduction.....	3
1.1.2	General dangers.....	3
1.1.3	Other symbols	3
1.1.4	Delivery of the system and the instruction manual	4
1.2	Guarantee and responsibility.....	4
2	Safety and prevention.....	5
2.1	Introduction.....	5
2.2	Personnel training	5
3	Technical description of the burner	6
3.1	Burner designation	6
3.2	Models available.....	7
3.3	Burner categories - Countries of destination	7
3.4	Technical data	7
3.5	Electrical data.....	7
3.6	Maximum dimensions.....	8
3.7	Firing rates	9
3.8	Test boiler.....	10
3.9	Burner equipment.....	10
3.10	Burner description	11
3.11	Electrical panel description.....	12
3.12	Flame control (LMV51...).....	13
3.13	Servomotor.....	15
4	Installation	16
4.1	Notes on safety for the installation	16
4.2	Handling	16
4.3	Preliminary checks	16
4.4	Operating position	17
4.5	Preparing the boiler	17
4.5.1	Boring the boiler plate	17
4.5.2	Blast tube length.....	17
4.6	Securing the burner to the boiler	17
4.7	Access to head internal part.....	18
4.8	Probe-electrode position	19
4.9	Gas butterfly valve.....	19
4.10	Combustion head adjustment.....	20
4.11	FGR duct system.....	21
4.11.1	Flue gas recirculation line sizing	22
4.11.2	Calculating the percentage of recirculated flue gas	22
4.12	Gas pressures	23
4.12.1	Gas feeding line (Example) - Please refer to the gas train documentation	23
4.12.2	Gas train.....	24
4.12.3	Gas train installation.....	24
4.12.4	Gas pressure.....	25
4.13	Electrical wiring	26
4.13.1	Supply cables and external connections passage	27
5	Start-up, calibration and operation of the burner	28
5.1	Notes on safety for the first start-up	28
5.2	Adjustments prior to ignition	28
5.3	Burner start-up	29
5.4	FGR commissioning	30

5.5	Air / fuel adjustment	31
5.5.1	Air adjustment for maximum output	31
5.5.2	Air/fuel adjustment and output modulation system	31
5.5.3	Burner adjustment.....	31
5.5.4	Output upon ignition	31
5.5.5	Maximum output	31
5.5.6	Minimum output	31
5.6	Final adjustment of the pressure switches	32
5.6.1	Air pressure switch.....	32
5.7	Final checks (with burner operating).....	32
6	Maintenance	33
6.1	Notes on safety for the maintenance	33
6.2	Maintenance programme	33
6.2.1	Maintenance frequency.....	33
6.2.2	Safety test - with gas ball valve closed	33
6.2.3	Checking and cleaning.....	33
6.2.4	Safety components	34
6.2.5	Voltage on the QRI sensor.....	35
6.2.6	Checking the air and gas pressure on the combustion head	35
6.2.7	Checking the air and gas pressure on the combustion head	35
6.3	Checking the position of the rpm sensor.....	36
6.4	Opening the burner	37
6.5	Closing the burner.....	37
7	Faults - Probable causes - Solutions	38
A	Appendix - Accessories	39
B	Appendix - Electrical panel layout.....	40

1 Information and general warnings

1.1 Information about the instruction manual

1.1.1 Introduction

The instruction manual supplied with the burner:

- is an integral and essential part of the product and must not be separated from it; it must therefore be kept carefully for any necessary consultation and must accompany the burner even if it is transferred to another owner or user, or to another system. If the manual is lost or damaged, another copy must be requested from the Technical Assistance Service of the area;
- is designed for use by qualified personnel;
- offers important indications and instructions relating to the installation safety, start-up, use and maintenance of the burner.

Symbols used in the manual

In some parts of the manual you will see triangular DANGER signs. Pay great attention to these, as they indicate a situation of potential danger.

1.1.2 General dangers

The **dangers** can be of **3 levels**, as indicated below.



Maximum danger level!
This symbol indicates operations which, if not carried out correctly, cause serious injury, death or long-term health risks.



This symbol indicates operations which, if not carried out correctly, may cause serious injury, death or long-term health risks.



This symbol indicates operations which, if not carried out correctly, may cause damage to the machine and/or injury to people.

1.1.3 Other symbols



DANGER: LIVE COMPONENTS
This symbol indicates operations which, if not carried out correctly, lead to electric shocks with lethal consequences.



DANGER: FLAMMABLE MATERIAL
This symbol indicates the presence of flammable materials.



DANGER: BURNING
This symbol indicates the risks of burns due to high temperatures.



DANGER: CRUSHING OF LIMBS
This symbol indicates the presence of moving parts: danger of crushing of limbs.



WARNING: MOVING PARTS
This symbol indicates that you must keep limbs away from moving mechanical parts; danger of crushing.



DANGER: EXPLOSION

This symbol signals places where an explosive atmosphere may be present. An explosive atmosphere is defined as a mixture - under atmospheric conditions - of air and flammable substances in the form of gases, vapours, mist or dust in which, after ignition has occurred, combustion spreads to the entire unburned mixture.



PERSONAL PROTECTION EQUIPMENT

These symbols indicate the equipment that must be worn and kept by the operator for protection against threats against safety and/or health while at work.



OBLIGATION TO ASSEMBLE THE COVER AND ALL THE SAFETY AND PROTECTION DEVICES

This symbol signals the obligation to reassemble the cover and all the safety and protection devices of the burner after any maintenance, cleaning or checking operations.



ENVIRONMENTAL PROTECTION

This symbol gives indications for the use of the machine with respect for the environment.



IMPORTANT INFORMATION

This symbol indicates important information that you must bear in mind.



This symbol indicates important information that you must bear in mind.



This symbol indicates a list.

Abbreviations used

Ch.	Chapter
Fig.	Figure
Page	Page
Sec.	Section
Tab.	Table

1.1.4 Delivery of the system and the instruction manual

When the system is delivered, it is important that:

- the instruction manual is delivered to the user by the system manufacturer, with the recommendation to keep it in the room where the heat generator is to be installed.
- The instruction manual shows:
 - the serial number of the burner;

.....

- the address and telephone number of the nearest Assistance Centre.

.....

.....

.....

- The system supplier must carefully inform the user about:
 - the use of the system;
 - any further tests that may be required before activating the system;
 - maintenance, and the need to have the system checked at least once a year by a representative of the manufacturer or another specialised technician. To ensure a periodic check, the manufacturer recommends the drawing up of a Maintenance Contract.

1.2 Guarantee and responsibility

The manufacturer guarantees its new products from the date of installation, in accordance with the regulations in force and/or the sales contract. At the moment of the first start-up, check that the burner is integral and complete.



WARNING

Failure to observe the information given in this manual, operating negligence, incorrect installation and carrying out of non authorised modifications will result in the annulment by the manufacturer of the guarantee that it supplies with the burner.

In particular, the rights to the guarantee and the responsibility will no longer be valid, in the event of damage to things or injury to people, if such damage/injury was due to any of the following causes:

- incorrect installation, start-up, use and maintenance of the burner;
- improper, incorrect or unreasonable use of the burner;
- intervention of unqualified personnel;
- carrying out of unauthorised modifications on the equipment;
- use of the burner with safety devices that are faulty, incorrectly applied and/or not working;
- installation of untested supplementary components on the burner;
- powering of the burner with unsuitable fuels;
- faults in the fuel supply system;
- continuation of use of the burner when a fault has occurred;
- repairs and/or overhauls incorrectly carried out;
- modification of the combustion chamber with inserts that prevent the regular development of the structurally established flame;
- insufficient and inappropriate surveillance and care of those burner components most likely to be subject to wear and tear;
- use of non-original components, including spare parts, kits, accessories and optional;
- force majeure.

The manufacturer furthermore declines any and every responsibility for the failure to observe the contents of this manual.

2 Safety and prevention

2.1 Introduction

The burners have been designed and built in compliance with current regulations and directives, applying the known technical rules of safety and envisaging all the potential danger situations. It is necessary, however, to bear in mind that the imprudent and clumsy use of the equipment may lead to situations of death risk for the user or third parties, as well as the damaging of the burner or other items. Inattention, thoughtlessness and excessive confidence often cause accidents; the same applies to tiredness and sleepiness.

It is a good idea to remember the following:

- The burner must only be used as expressly described. Any other use should be considered improper and therefore dangerous.

In particular:

it can be applied to boilers operating with water, steam, diathermic oil, and to other uses expressly foreseen by the manufacturer;

the type and pressure of the fuel, the voltage and frequency of the electrical power supply, the minimum and maximum deliveries for which the burner has been regulated, the pressurisation of the combustion chamber, the dimensions of the combustion chamber and the room temperature must all be within the values indicated in the instruction manual.

- Modification of the burner to alter its performance and destinations is not allowed.
- The burner must be used in exemplary technical safety conditions. Any disturbances that could compromise safety must be quickly eliminated.
- Opening or tampering with the burner components is not allowed, apart from the parts requiring maintenance.
- Only those parts envisaged by the manufacturer can be replaced.



The manufacturer guarantees safety and proper functioning only if all burner components are intact and positioned correctly.

2.2 Personnel training

The user is the person, body or company that has acquired the machine and intends to use it for the specific purpose. He is responsible for the machine and for the training of the people working around it.

The user:

- undertakes to entrust the machine exclusively to suitably trained and qualified personnel;
- undertakes to inform his personnel in a suitable way about the application and observance of the safety instructions. With that aim, he undertakes to ensure that everyone knows the use and safety instructions for his own duties;
- Personnel must observe all the danger and caution indications shown on the machine.
- Personnel must not carry out, on their own initiative, operations or interventions that are not within their province.
- Personnel must inform their superiors of every problem or dangerous situation that may arise.
- The assembly of parts of other makes, or any modifications, can alter the characteristics of the machine and hence compromise operating safety. The manufacturer therefore declines any and every responsibility for any damage that may be caused by the use of non-original parts.

In addition:



- must take all the measures necessary to prevent unauthorised people gaining access to the machine;
- the user must inform the manufacturer if faults or malfunctioning of the accident prevention systems are noticed, along with any presumed danger situation;
- personnel must always use the personal protective equipment envisaged by legislation and follow the indications given in this manual.

3 Technical description of the burner

3.1 Burner designation

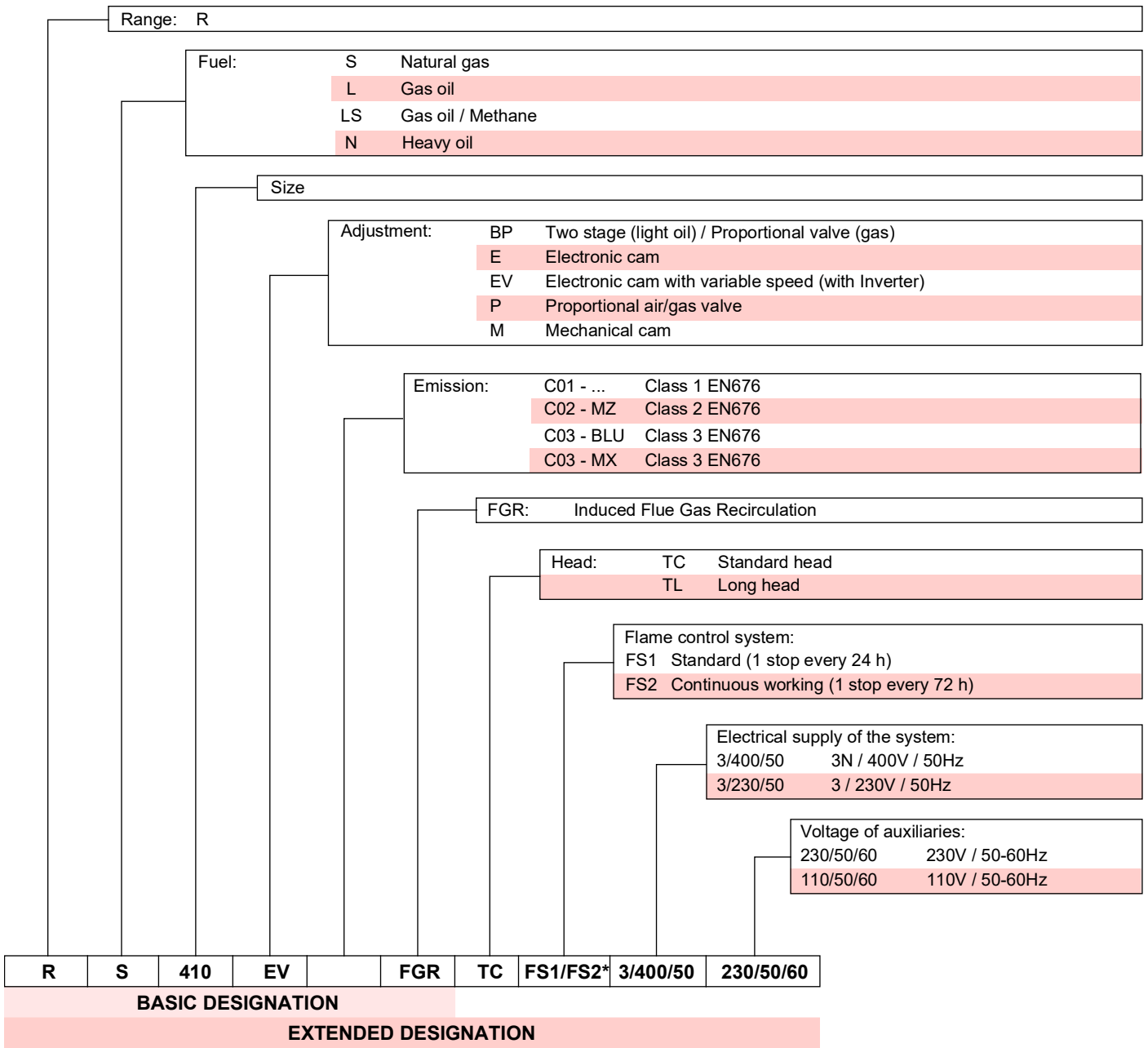

*The burner leaves the factory set up for FS1 operation. If FS2 operation is required, see the manual of the electronic cam.

3.2 Models available

Designation	Voltage	Start-up	Code
RS 410/EV FGR FS1/FS2	3/400/50	Inverter	20162652
RS 510/EV FGR FS1/FS2	3/400/50	Inverter	20162653
RS 610/EV FGR FS1/FS2	3/400/50	Inverter	20162655

Tab. A

3.3 Burner categories - Countries of destination

Destination country	Gas category
AT - BG - CH - CZ - DK - EE - ES - FI - GB - GR - FR - HU - IE - IS - IT - LT - LV - NO - PT - RO - SE - SI - SK - TR	I _{2H}
BE	I _{2E(R)}
DE - LU - PL	I _{2E}

Tab. B

3.4 Technical data

Model	RS 410/EV FGR		RS 510/EV FGR	RS 610/EV FGR	
Power ⁽¹⁾ Delivery ⁽¹⁾	min - max	kW	595/1210 ÷ 3820	660/1800 ÷ 4800	912/2220 ÷ 5850
Fuels	Natural gas: G20 (methane gas)				
Operation	FS1: Intermittent (min. 1 stop in 24 hours) FS2: Continuous (min 1 stop 72 hours) The burner leaves the factory set for the intermittent operation				
Standard applications	Boilers: water, steam, diathermic oil				
Ambient temperature	°C		0 - 50		
Combustion air temperature	°C max		60		
Noise levels ⁽²⁾	Sound pressure Sound power	dB(A)	80 91	82.5 93.5	85 96
Weight of the burner complete with its packaging	kg		265	265	295
CE	CE-0476DP3335				

Tab. C

- (1) Reference conditions: Ambient temperature 20°C - Gas temperature 15°C - Barometric pressure 1013 mbar - Altitude 0 m a.s.l.
 (2) Sound pressure measured in manufacturer's combustion laboratory, with burner operating on test boiler and at maximum rated output. The sound power is measured with the "Free Field" method, as per EN 15036, and according to an "Accuracy: Category 3" measuring accuracy, as set out in EN ISO 3746.



In order to reduce the nitrogen oxides NO_x in case of FGR system, the maximum burner capacity obtained, changes within the limits agreed with the Riello Technical Dept. for the specific application.

3.5 Electrical data

Model	RS 510/EV FGR	RS 510/EV FGR	RS 610/EV FGR	
Main electrical supply	3N ~ 400V +/-10% 50 Hz			
Absorbed electrical power	kW max	10,8	14	17
Protection level	IP 54			

Tab. D

3.6 Maximum dimensions

The maximum dimensions of the burner are given in Fig. 1.

Bear in mind that inspection of the combustion head requires the burner to be opened and the rear part turned on the hinge.

The maximum dimensions of the open burner are indicated by the L and R positions.

The I position is reference for the refractory thickness of the boiler door.



* The gas adaptor is set also for DN 80 bore.

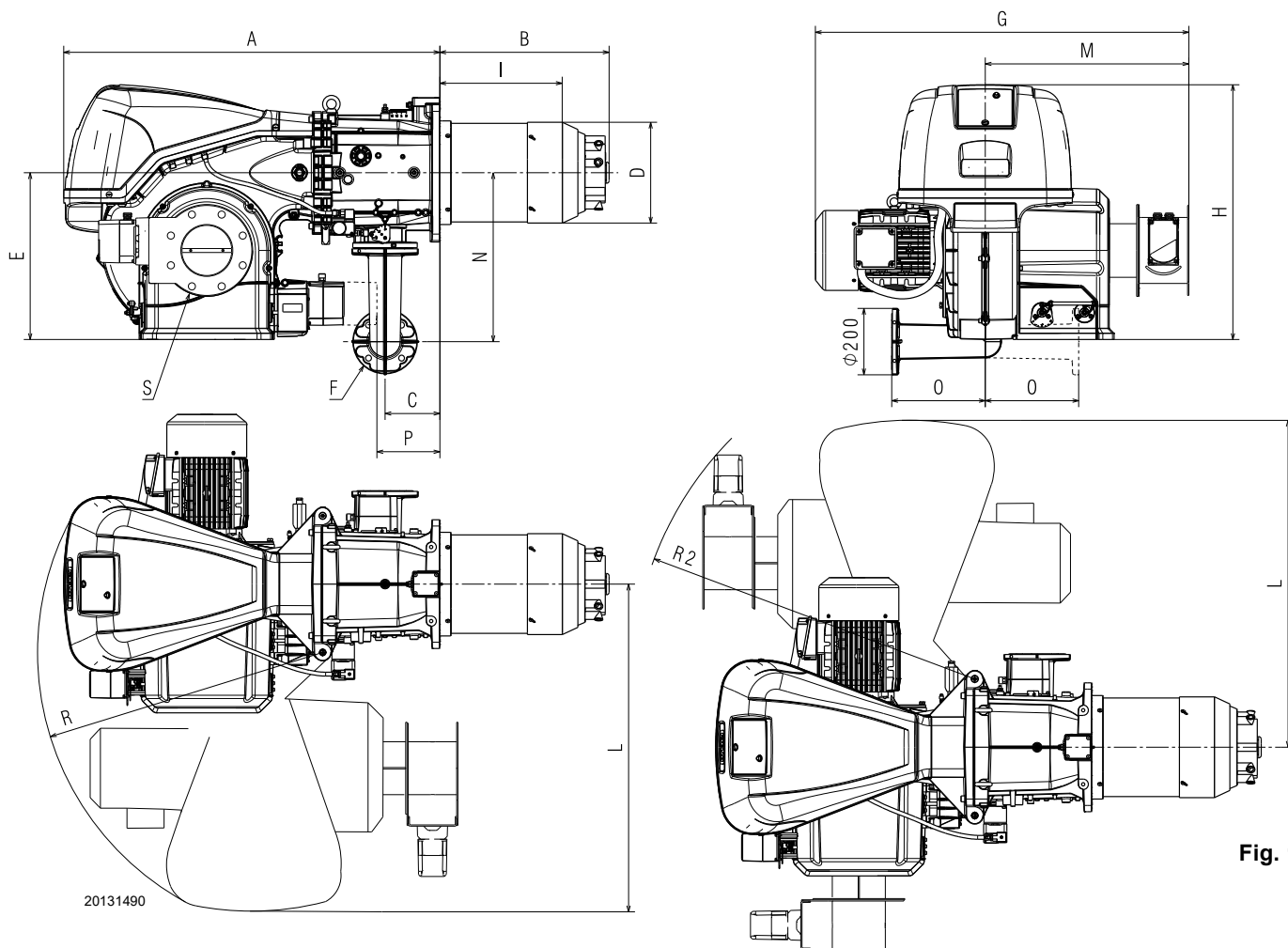

Fig. 1

mm	A	B	C	D	E	F*	G	H	I	L	M	N	O	P**	R
RS 410/EV BLU	1178	517	178	313	520	DN65	908	790	340	1015	400	528	290	177	890
RS 510/EV BLU	1178	517	178	313	520	DN65	908	790	340	1015	400	528	290	177	890
RS 610/EV BLU	1178	517	178	334	520	DN65	980	790	365	1015	400	528	290	177	890

Tab. E

** Maximum position for the extraction of the servomotor cover.

3.7 Firing rates

The **MAXIMUM OUTPUT** is chosen from within the diagram area (Fig. 2).

The **MINIMUM OUTPUT** must not be lower than the minimum limit of the diagram:

Model	kW
RS 410/EV FGR	595
RS 510/EV FGR	660
RS 610/EV FGR	912

Tab. F



WARNING

The firing rate value (Fig. 2) has been obtained considering an ambient temperature of 20 °C, an atmospheric pressure of 1013 mbar (approx. 0 m a.s.l.), and with the combustion head adjusted as shown on page 20.



WARNING

Pre-calibration of the combustion head only for the burner model RS 410/EV FGR:

If the maximum burner output of the burner falls within:

- area A of the firing rate, it is necessary to replace the internal shutter with that one supplied (no. 8 holes \varnothing 4,7 mm), Fig. 13 on page 19.

- area B of the firing rate, no modifications are required.

20164284

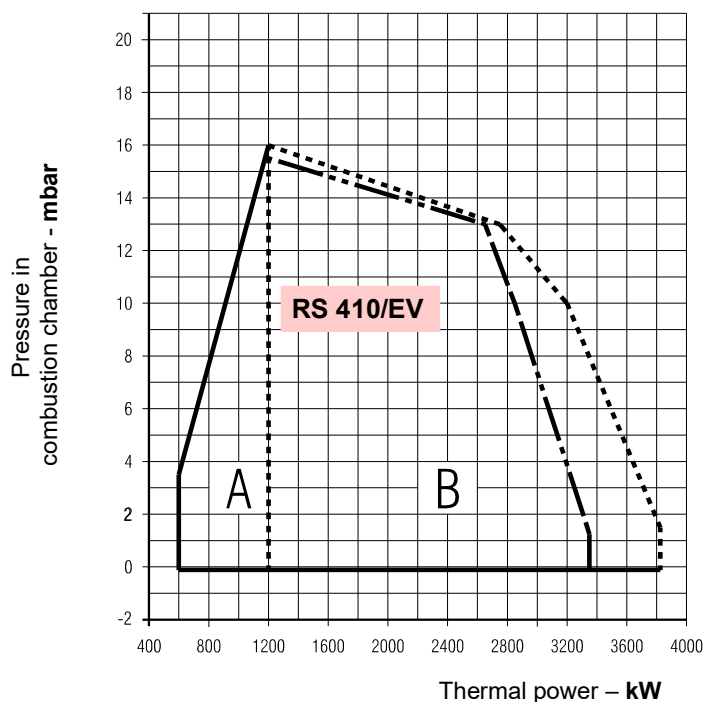
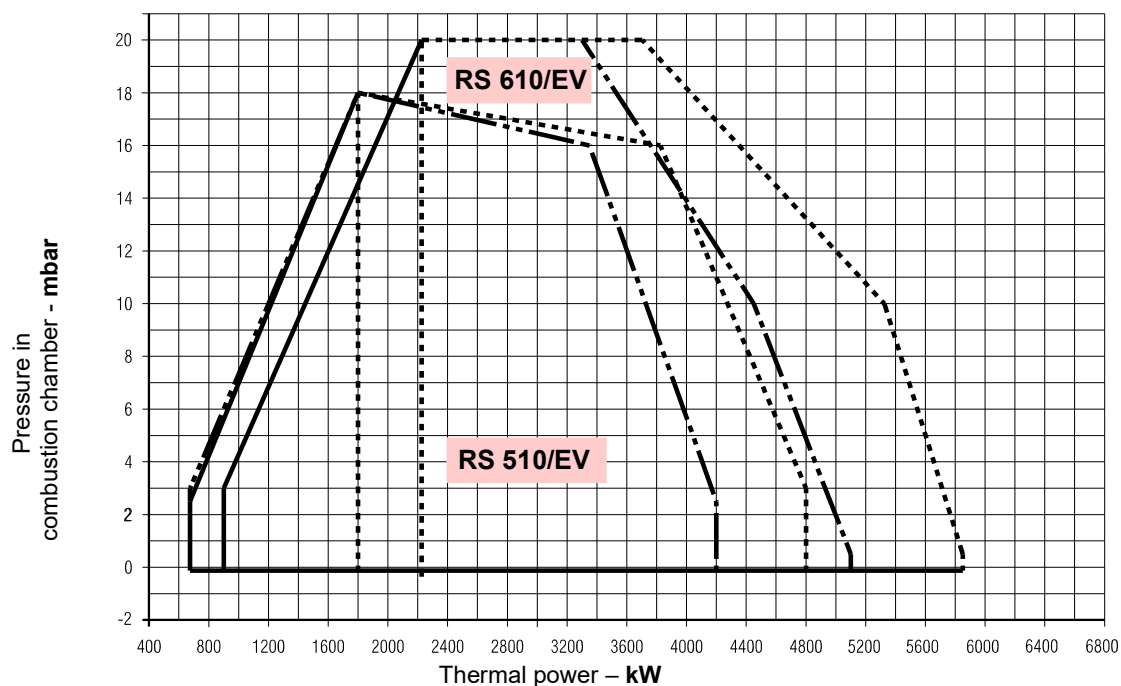

— — — Limit with active flue gas recirculation system

Fig. 2

3.8 Test boiler

The burner/boiler combination does not pose any problems if the boiler is EC approved and its combustion chamber dimensions are similar to those indicated in the diagram (Fig. 3).

If the burner must be combined with a boiler that has not been EC approved and/or its combustion chamber dimensions are clearly smaller than those indicated in the diagram, consult the manufacturer.

The firing rates were set in relation to special test boilers, according to EN 676 regulations.

In Fig. 3 you can see the diameter and length of the test combustion chamber.

Example:
Output 7000 kW - diameter 120 cm - length 6m

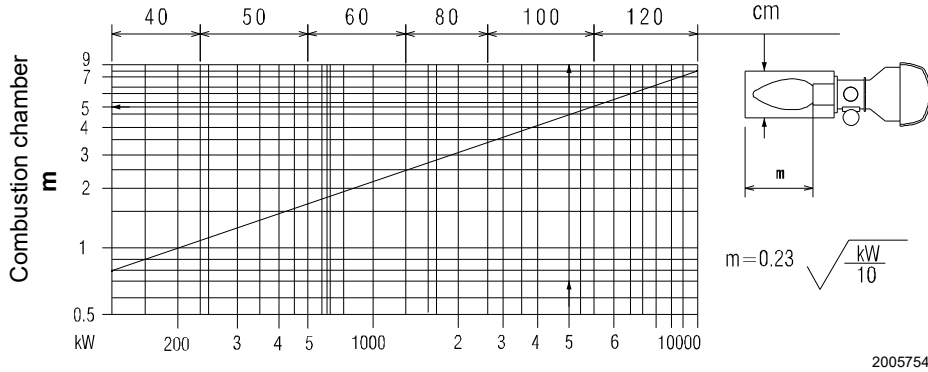

Fig. 3

3.9 Burner equipment

- Gasket for gas train adaptor. No. 1
- Adaptor for gas train. No. 1
- Screws for fixing the gas train adaptor: M 16 x 70 No. 4
- Thermal insulation screen No. 1
- M 18 x 60 screws to secure the burner flange to the boiler . No. 4
- Cable grommets kit for optional electrical wiring input. . . . No. 1
- M16 nuts to fix the gas elbow to the pipe coupling No. 8
- Stud bolts M16X60 to fix the gas elbow to the pipe coupling . No. 1
- Internal shutter (RS 410/EV FGR) No. 1
- Instructions No. 1
- Spare parts list No. 1



It is recommended to tighten the screws of the gas flange with a tightening torque of **40 Nm ±10%**.

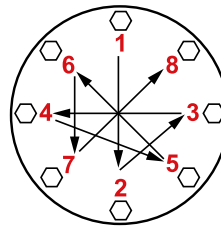

Tighten the nuts gradually (first to 30%, then to 60% up to 100%) according to the cross pattern shown in the figure.

3.10 Burner description

ASSEMBLY VIEW

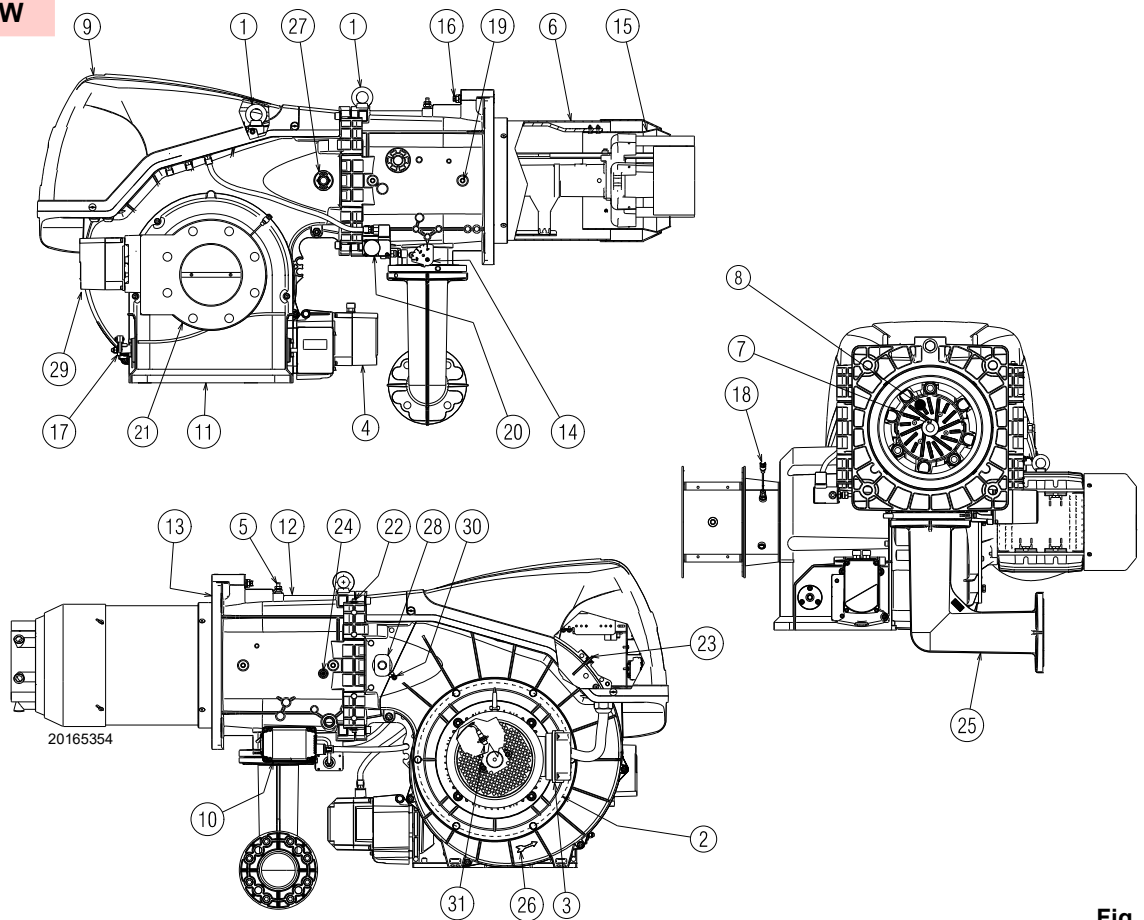





Fig. 4

- | | |
|-------------------------|----------------------------|
| 1 Lifting rings | 28 UV flame sensor |
| 2 Fan | 29 Servomotor for flue gas |
| 3 Fan motor | 30 Air cooling intake |
| 4 Air damper servomotor | 31 Rpm sensor |

- | |
|---|
| 5 Combustion head gas pressure test point |
| 6 Combustion head |
| 7 Ignition electrode |
| 8 Flame stability disk |
| 9 Electrical panel casing |
| 10 Gas butterfly valve servomotor |
| 11 Fan air inlet |
| 12 Pipe coupling |
| 13 Gasket for boiler fixing |
| 14 Gas butterfly valve |
| 15 Shutter |
| 16 Combustion head movement screw |
| 17 Lever for controlling the dampers with graduated scale |

 The burner can be opened to the right or to the left without links to the fuel supply side.

 **WARNING** To open the burner see section "Access to head internal part" on page 18.

 Wait for the components in contact with heat sources to cool down completely.

- | |
|--|
| 22 Hinge for opening the burner |
| 23 Pressure test point for air pressure switch "+" |
| 24 Combustion head air pressure test points |
| 25 Gas train adapter |
| 26 Indication for checking the rotation direction of the purging motor |
| 27 Flame inspection window |

3.11 Electrical panel description

20165363

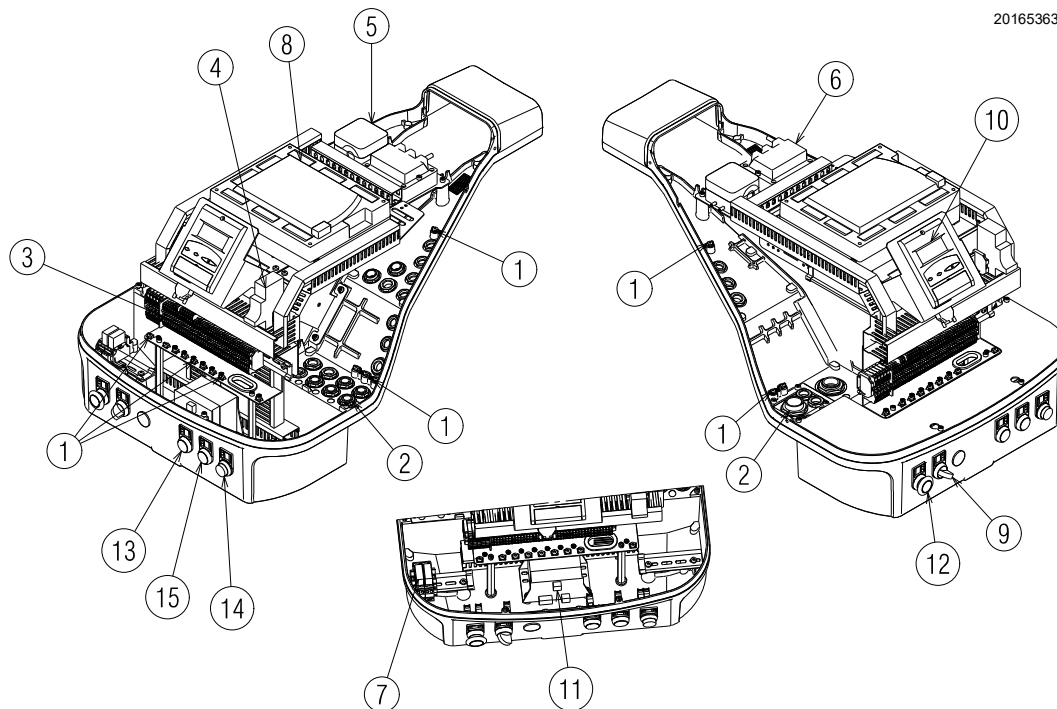

Fig. 5

- 1 Earth terminal
- 2 Supply cables and external connections passage
- 3 Main terminal supply board
- 4 Auxiliary circuits fuse (includes a spare fuse)
- 5 Air pressure switch
- 6 Ignition transformer
- 7 Free contact relay
- 8 Electronic cam
- 9 "0/AUTO" selector
- 10 Operator panel with LCD display
- 11 Flame control power supply
- 12 Emergency button
- 13 Light signalling "POWER ON"
- 14 Light signalling burner lock-out and reset button
- 15 Light signalling "OVERLOAD FAN MOTOR"

3.12 Flame control (LMV51...)

Warnings



To avoid accidents, material or environmental damage, observe the following instructions!

The LMV51... is a safety device! Avoid opening or modifying it, or forcing its operation. Riello S.p.A. cannot assume any responsibility for damage resulting from unauthorised interventions!

Risk of explosion!

An incorrect configuration can provoke fuel overcharging, with the consequential risk of explosion! Operators must be aware that incorrect settings made on the AZL5... display and operating unit and incorrect settings of the fuel and / or air actuator positions can lead to dangerous burner operating conditions.

- All interventions (assembly and installation operations, assistance, etc.) must be carried out by qualified personnel.
- Before modifying the wiring in the LMV52 flame control connection area, fully disconnect the system from the power supply (omnipolar separation). Check the system is not powered and cannot be accidentally reconnected. Failure to do this will lead to the risk of electrocution.
- Protection against electrocution from the LMV5... flame control and all connected electric components is obtained with correct assembly.
- Before any intervention (assembly and installation operations, assistance, etc.), ensure the wiring is in order and that the parameters are correctly set, then make the safety checks.
- Falls and collisions can negatively affect the safety functions.

In this case, the flame control must not be operated, even if it displays no evident damage.

- In programming mode, the position check of actuators and VSD (checking electronic fuel / air ratio control) is different from the check during automatic operation. As for automatic operation, the actuators are guided together to the positions requested and, if an actuator does not reach the position requested, adjustments are made until the position is actually reached. However, in contrast to automatic operation, there are no time limits to these corrective actions.

The other actuators maintain their positions until all actuators have reached the positions currently required. This is absolutely important to set the fuel / air ratio control system.

During the time the fuel / air ratio curves are being programmed, the person making the plant settings must continuously monitor the quality of the combustion process (e.g. by means of a flue gas analyser). Also, if combustion levels are poor, or in the event of dangerous situations, the commissioning engineer must take appropriate action (e.g. switching off manually).

To ensure the safety and reliability of the LMV5... system, the following instructions must also be followed:

- avoid conditions that can favour the development of condensate and humidity. Otherwise, before switching on again, make sure that the entire flame control is perfectly dry!
- Static charges must be avoided since they can damage the flame control's electronic components when touched.



D9301

Fig. 6

Mechanical structure

The LMV5... flame control is a system to check the burners, based on a microprocessor and equipped with components to adjust and monitor medium and large capacity forced draught burners.

The base flame control of the LMV5... system incorporates the following components:

- Burner control with gas valve proving system
- Electronic fuel / air ratio control with a maximum of 4 actuators
- Optional PID temperature / pressure controller (load controller)
- Optional VSD module Mechanical design

Installation notes

- Check the electric wiring inside the boiler complies with the national and local safety regulations.
- Do not confuse the powered conductors with the neutral ones.
- Make certain that strain relief of the connected cables is in compliance with the relevant standards (e.g. as per DIN EN 60730 and DIN EN 60 335).
- Ensure that spliced wires cannot get into contact with neighbouring terminals. Use adequate ferrules.
- Arrange the HV ignition cables separately, as far as possible from the flame control and the other cables.
- The burner manufacturer must protect unused AC 230V terminals with dummy plugs (refer to sections Suppliers of other accessory items).
- When wiring the unit, make sure that AC 230V mains voltage cables are run strictly separate from extra low-voltage cables to avoid risks of electrical shock hazard.

Electrical connection of flame detector

It is important for signal transmission to be almost totally free of any disturbances or loss:

- always separate the detector cables from the other cables:
 - Line capacitance reduces the magnitude of the flame signal.
 - Use a separate cable.
- Respect the allowed cable lengths.

Technical data

LMV51... basic unit	Mains voltage	AC 230V -15% / +10%
	Mains frequency	50 / 60 Hz ± 6%
	Power absorption	< 30W (normal)
	Safety class	I, with components in compliance with II and III, according to DIN EN 60730-1
Load on 'input' terminals	F1 unit fuse (internal)	6.3 AT
	Primary perm. mains fuse (external)	Max. 16 AT
	Undervoltage	
	• Safety switch-off from operating position to mains voltage	< AC 186V
	• Restart when mains voltage picks up	> AC 188V
	Oil pump / magnetic clutch (nominal voltage)	
	• Nominal current	2A
	• Power factor	cosφ > 0.4
	Air pressure switch test valve (nominal voltage)	
	• Nominal current	0.5A
• Power factor	cosφ > 0.4	
Load on 'output' terminals	Total load on the contacts:	
	• Mains voltage	AC 230V -15 % / +10%
	• Total unit input current (safety circuit) load on contacts due to:	Max. 5 A
	- Fan motor contactor	
	- Ignition transformer	
	- Valve	
	- Oil pump / magnetic clutch	
	Single contact loading:	
	Fan motor contactor (nominal voltage)	
	• Nominal current	1A
	• Power factor	cosφ > 0.4
	Alarm output (nominal voltage)	
	• Nominal current	1A
	• Power factor	cosφ > 0.4
	Ignition transformer (nominal voltage)	
	• Nominal current	2A
	• Power factor	cosφ > 0.2
	Fuel gas valve (nominal voltage)	
	• Nominal current	2A
	• Power factor	cosφ > 0.4
Fuel oil valve (nominal voltage)		
• Nominal current	1A	
• Power factor	cosφ > 0.4	
Cable lengths	Main line	Max. 100m (100 pF/m)
Environmental conditions	Operation	DIN EN 60721-3-3
	Climatic conditions	Class 3K3
	Mechanical conditions	Class 3M3
	Temperature range	-20...+60°C
	Humidity	< 95% RH

Tab. G

3.13 Servomotor

Warnings



WARNING

To avoid accidents, material or environmental damage, observe the following instructions!

Avoid opening, modifying or forcing the actuators.

- All interventions (assembly and installation operations, assistance, etc.) must be carried out by qualified personnel.
- Before modifying the wiring in the SQM4... system connection area, fully disconnect the burner control device from the power supply (omnipolar separation).
- To avoid the risk of electrocution, protect the connection terminals in a suitable manner and correctly fix the cover.
- Check the wiring is in order.
- Falls and collisions can negatively affect the safety functions. In this case, the unit must not be operated, even if it displays no evident damage.

Assembly notes

- Check the relevant national safety standards are respected.
- The connection between the actuator command shaft and the control element must be rigid, without any mechanical play.
- To avoid an excessive load on the bearings due to rigid hubs, the use of compensation clutches without any mechanical play is recommended (e.g. metal bellows-type clutches).

Installation notes

- Arrange the H.V. ignition cables separately, as far as possible from the flame control and the other cables.
- To avoid the risk of electrocution, make sure that the 230V AC section of the SQM4... unit is fully separated from the functional low-voltage section.
- The static torque is reduced when the electrical supply of the actuator is switched off.
- The housing cover may only be removed for short periods of time for wiring or when making the addressing. In similar cases, make sure that dust or dirt does not penetrate inside the actuator.
- The actuator comprises a PCB with ESD-sensitive components.
- The top side of the board carries a cover which affords protection against direct contact. This protective cover must not be removed! The underside side of the board must not be touched.



WARNING

During the maintenance or replacement of the actuators, be careful not to invert the connectors.

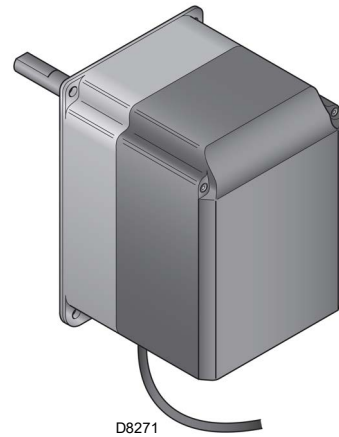

Fig. 7

Technical data

Operating voltage	AC 2 x 12V via bus cable from the base unit or via a separate transformer
Safety class	extra low-voltage with safe isolation from mains voltage
Power absorption	
– SQM45...	9...15 VA
– SQM48...	26...34 VA
Degree of protection	to EN 60 529, IP 54, provided adequate cable entries are used
Cable connection	RAST3,5 connectors
Rotation direction	- Anticlockwise (standard) - Clockwise (inverted rotation)
Nominal torque (max)	
– SQM45...	3 Nm
– SQM48...	20 Nm
Holding torque (max)	
– SQM45...	1.5 Nm
– SQM48...	20 Nm
Running time (min.) for 90°	
– SQM45...	10 s.
– SQM48...	30 s.
Weight	
– SQM45...	1 kg approx.
– SQM48...	1.6 kg approx.
Environmental conditions:	
Operation	DIN EN 60 721-3-3
Climatic conditions	Class 3K3
Mechanical conditions	Class 3M3
Temperature range	-20...+60°C
Humidity	< 95% RH

Tab. H

4.4 Operating position



- The burner is designed to operate only in positions 1, 2, 3 and 4 (Fig. 9).
- Installation 1 is preferable, as it is the only one that allows the maintenance operations as described in this manual.
- Installations 2, 3 and 4 permit operation but make maintenance and inspection of the combustion head more difficult.



- Any other position could compromise the correct operation of the appliance.
- Installation 5 is prohibited for safety reasons.

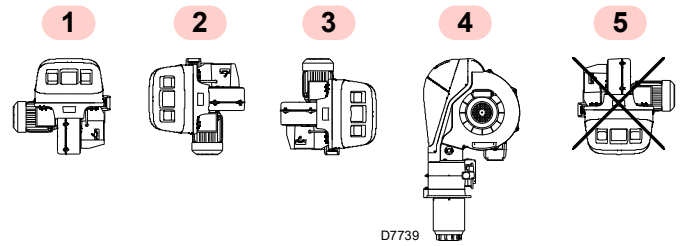

Fig. 9

4.5 Preparing the boiler

4.5.1 Boring the boiler plate

Drill the combustion chamber locking plate as shown in Fig. 10 (Tab. I). The position of the threaded holes can be marked using the thermal screen supplied with the burner.

4.5.2 Blast tube length

The length of the blast tube must be selected according to the indications provided by the manufacturer of the boiler, and in any case it must be greater than the thickness of the boiler door complete with its fettling.

For boilers with front flue passes 1)(Fig. 11) or flame inversion chamber, a protection in refractory material 5) must be inserted between the boiler fettling 2) and the blast tube 4).

The refractory can have a conical shape (minimum 60°).

This protective fettling must not compromise the extraction of the blast tube.

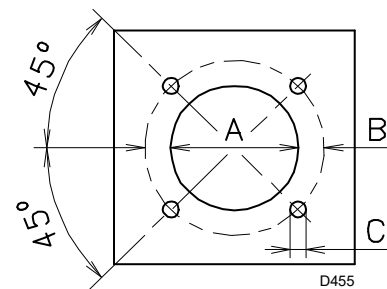

Fig. 10

mm	A	B	C
RS 410/EV FGR	335	452	M18
RS 510/EV FGR	335	452	M18
RS 610/EV FGR	350	452	M18

Tab. I

4.6 Securing the burner to the boiler



Prepare a suitable lifting system using the rings 3)(Fig. 11), after removing the fixing screws 7) of the casing 8).

- Fit the heat insulation supplied onto the blast tube 4)(Fig. 11).
- Fit the entire burner onto the boiler hole prepared previously (Fig. 10), and fasten with the screws supplied.



The seal between burner and boiler must be airtight.

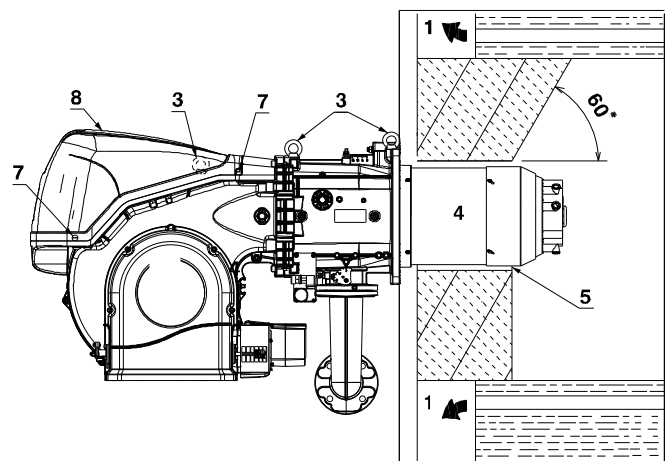

Fig. 11

4.7 Access to head internal part

The burner leaves the factory set for opening to the left, therefore maintaining the pin 1)(Fig. 12) in the housing.

To open the burner towards the left, proceed as follows:

- A** disconnect the plug/socket 9)(Fig. 12) of the maximum gas pressure switch;
- B** remove the screws 2);
- C** open the burner to a maximum of 100-150 mm by rotating around the hinge and release the cables of the probe 5) and electrode 11);
- D** fully open the burner as in Fig. 12;
- E** undo the screw 4) with pressure test point;
- F** release the head by lifting it from its housing 3), then take out the combustion head.



WARNING

To open the burner from the opposite side, before removing the pin 1)(Fig. 12), make sure that the 4 screws 2) are tight. Then shift the pin 1) to the opposite side, only then is it possible to remove the screws 2). Disconnect the socket 9 (Fig. 12) of the maximum gas pressure switch, then proceed as described above at point (C).

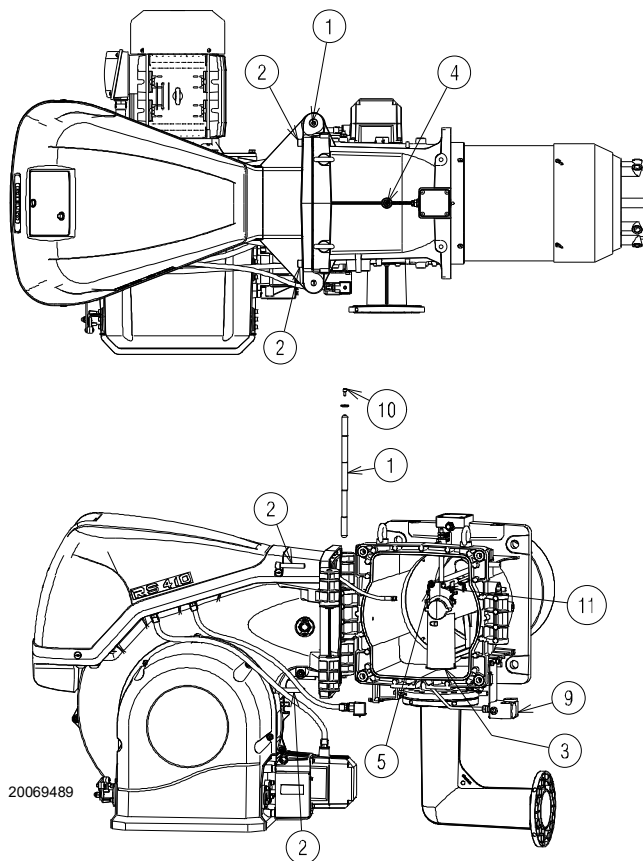

Fig. 12

4.8 Probe-electrode position



Check that the probe and the electrode are placed as in Fig. 13, according to the dimensions indicated.

RS 510-610/EV FGR

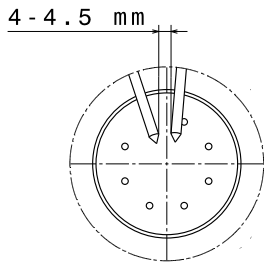

RS 410/EV FGR

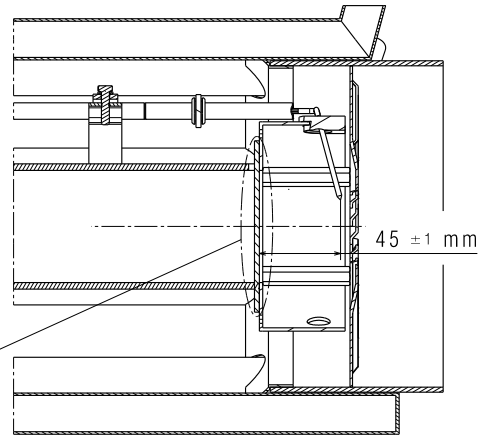
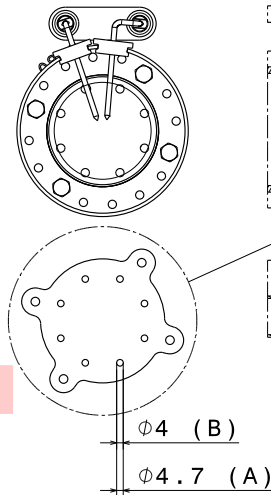

20164331

Fig. 13

4.9 Gas butterfly valve

If necessary, replace the gas butterfly valve. The correct position is shown in Fig. 14.

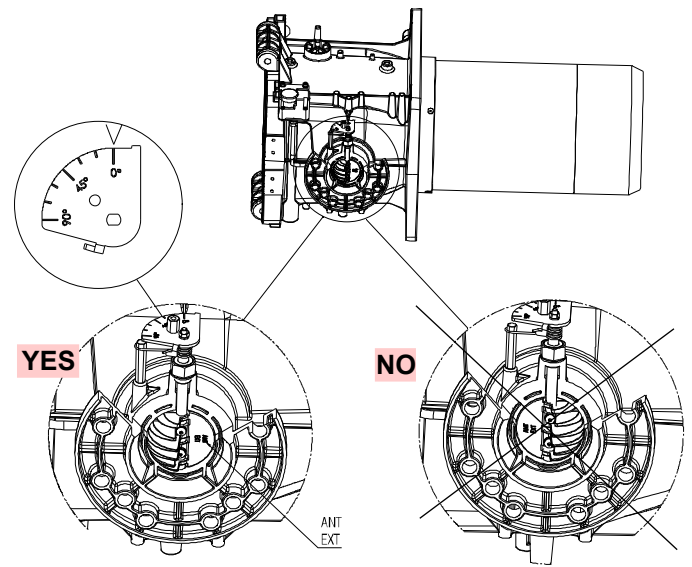

20078516

Fig. 14

4.10 Combustion head adjustment

Rotate the screw 1) until the notch you have found corresponds with the front surface of the screw itself.

The combustion head is opened by turning the screw 1) anti-clockwise.

The combustion head is closed by turning the screw 1) clockwise (Fig. 15)



The burner leaves the factory with the combustion head set at notch 0 (Fig. 15).

This setting allows to secure the movable components during the transport of the burner.

Before starting up the burner, carry out the settings according to the required output and indicated in the diagram (Fig. 16).

NOTE:
Depending on the specific application, the adjustment can be modified.

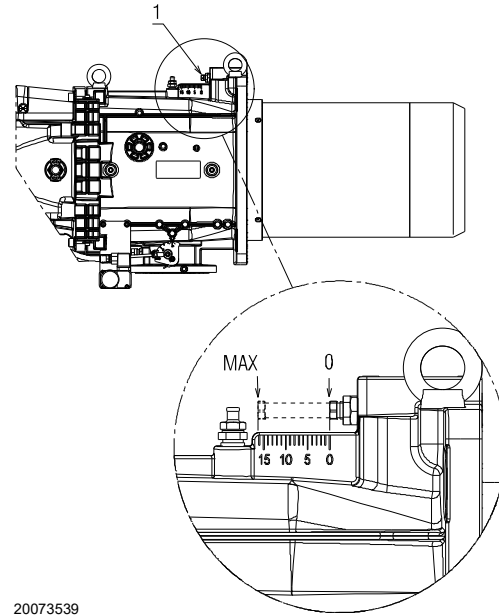

20073539

Fig. 15

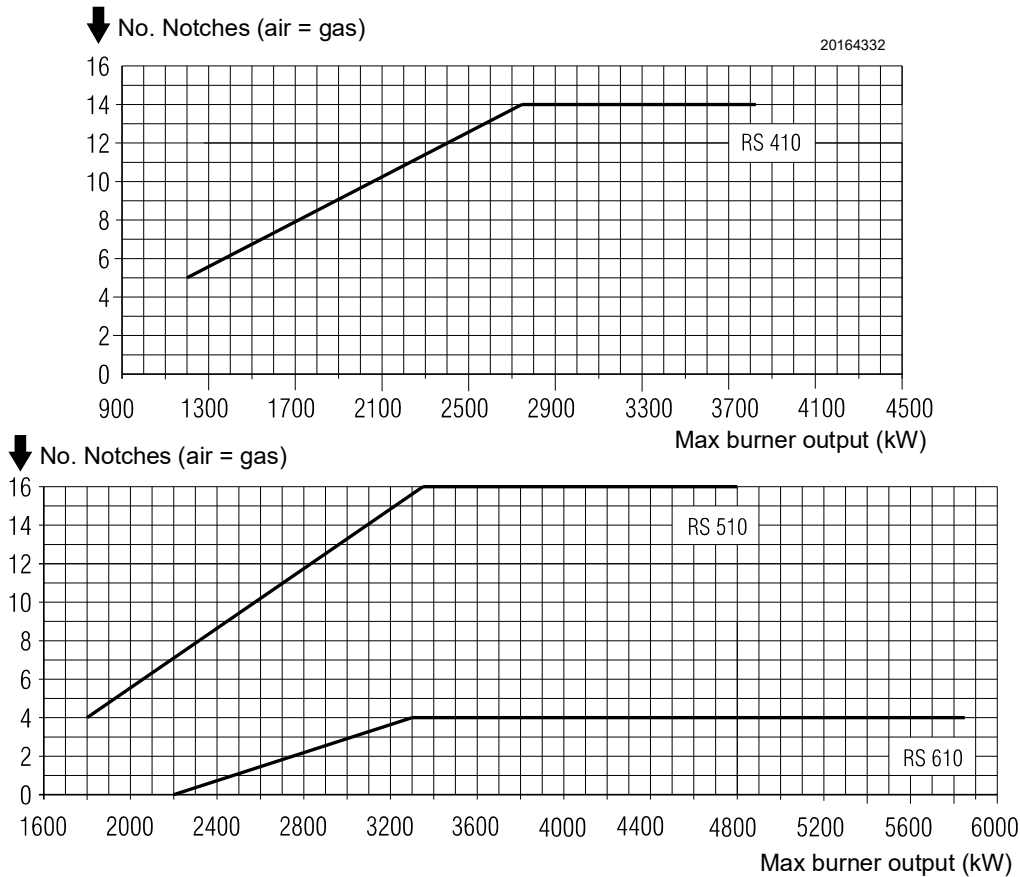

Fig. 16



The combustion head can be adjusted within the following ranges:

RS 410/EV FGR: 5 - 14;

RS 510/EV FGR: 4 - 16;

RS 610/EV FGR: 0 - 4.

The adjustment cannot be carried out outside these ranges.

4.11 FGR duct system

- Normally the duct would connect to the stack as shown in Fig. 17, with a 45° cut facing the flue gas flow and with the centre of the cut centred in the stack. The duct could be made to the smoke box, but must still be located with the same 45° cut facing the flue gas flow stream and with the centre of the cut in the centre of the stream.
- The duct should be routed in a manner that has the minimum number of elbows and provides for the normal expansion and contraction of the piping. Long duct runs can change length by over 1" and can put an extreme load on the connecting points that could cause component failures. The design must include offsets that will allow for the required movement of the piping without undue force on the burner or stack.
- Duct expansion and contraction can be managed by using two relatively long duct runs that are 90° opposed to each other. A small movement in the angle between these two legs will provide the space needed to absorb the expansion and contraction. The ends of the FGR duct must be securely attached to allow this to work properly, and prevent high loads from being applied to the burner or stack.
- A condensation drip leg must be provided upstream of the FGR control valve and the FGR shut off valve (if used).

There must be sufficient condensate drip legs and catch space (volume of drip legs) to prevent the condensation from flowing through the control valves and into the fan. In cases of heavy condensation, a condensate drip leg may be required on the bottom of the housing, to remove condensate.

- Determine if pipe reducers are needed for the connection to the FGR control valve and the FGR shut off valve.
- The duct must be properly supported, handling both the weight of the duct and to control the thermal expansion and contraction. The supports may need to be anchored to provide this stability in the FGR duct.



Uncontrolled condensation can cause premature failure of the control valves, fan and motor.

Adequate means must be provided to remove condensation from the system.

Cold start-up will generate significant amounts of condensation.

- The duct components must be seal welded, flanged or screwed together to provide an air tight duct. Air leakage into the duct will prevent the system from working properly. It is sufficient to only inspect the welds for a proper seal, they do not need to be leak tested.

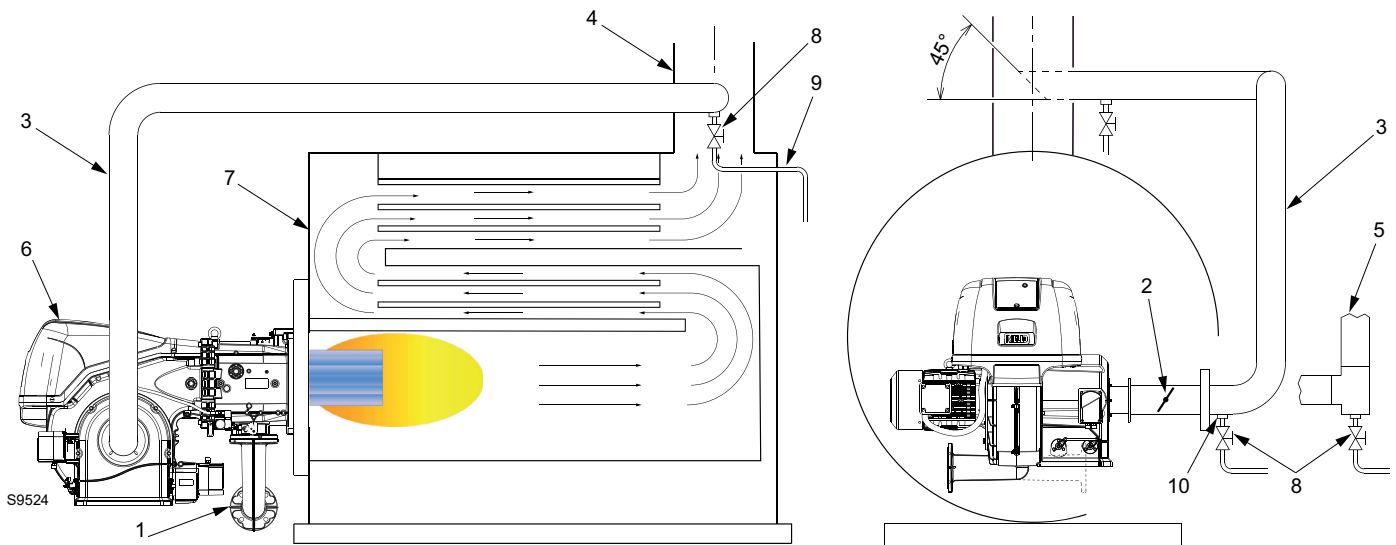

Fig. 17

Key (Fig. 17)

- 1 Primary gas supply inlet
- 2 Inducted FGR modulating damper



Wait for the components in contact with heat sources to cool down completely.

- 3 Flue gas recirculation pipe
- 4 Boiler stack
- 5 Alternate Construction Using "T"
- 6 Burner
- 7 Boiler
- 8 Drain Valve (Manual Ball Valve, Stainless Steel)
- 9 Drain line
- 10 Condensate Trap

4.11.1 Flue gas recirculation line sizing

The Tab. J can be helpful to correctly size the FGR pipes taking flue gases from boiler stack base up to the burner intake port.

Diameter of FGR pipe (inch)	RS 410/E FGR (m)	RS 510/E FGR (m)	RS 610/E FGR (m)
3"	-	-	-
4"	6.1	4.9	3
6"	45	30	24
8"	-	75	61

Tab. J

To account for the flow resistance at 90° elbows of the flue gas circuit, the following equivalent straight pipe length values can be considered, and shall be deducted from the maximum pipe length values indicated in Tab. J to obtain the maximum length of FGR pipe development in the considered instance:

Size of pipe	Pipe fittings	
	90° elbow (m)	45° elbow (m)
3"	2.2	1.2
4"	3	1.7
6"	4.5	2.4
8"	6.1	3.3

Tab. K

Example for RS 510/E FGR:

- foreseen overall pipe development: 24 m
- foreseen number of bends: 3

Start considering a 6" pipe.

In Tab. J you see that maximum allowed length is 30 m, then we must take off $3 \times 4.5 = 13.5$ m to account for bends. We then obtain a maximum pipe value of 16.5 m.

You understand that pipe diameter is too small so we must choose a 8" diameter.

Maximum allowed pipe length

$FGR = 75 - (3 \times 6.1) = 56.7$ m that is > 24 m so it is fine.

Maximum allowed pipe length (considering smooth steel pipes) is specified for every burner and pipe diameter.

To prepare the Tab. J a flue gas maximum temperature of 260°C was considered.

4.11.2 Calculating the percentage of recirculated flue gas

As a general rule, recirculated flue gas quantity must be adjusted so as to recirculate the smallest quantity necessary to obtain the required NOx rate.

Adjustment is carried out through the throttle valve located on FGR pipe. It is necessary to consider that too high a quantity of recirculated flue gas could lead to flame instability and excessively high CO rate.

To calculate the % of recirculated flue gas, use the formula below: $\% IFGR = (CO_2 R) / (CO_2 f) \times 100$.

Where:

- $(CO_2 R)$ is the percentage of CO_2 measured at the burner coupling
- $(CO_2 f)$ is the percentage of CO_2 measured at the stack

4.12 Gas pressures



Explosion danger due to fuel leaks in the presence of a flammable source.

Precautions: avoid knocking, attrition, sparks and heat.

Make sure the fuel interception tap is closed before performing any operation on the burner.



The fuel supply line must be installed by qualified personnel, in compliance with current standards and laws.

4.12.1 Gas feeding line (Example) - Please refer to the gas train documentation for more information

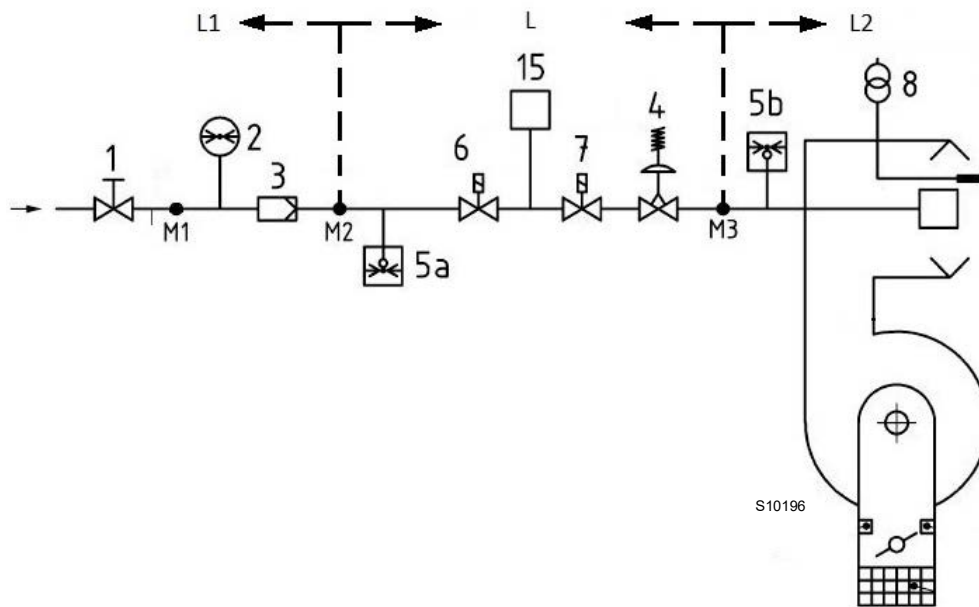

Fig. 18

Key (Fig. 18)

- 1 Manually operated shut-off valve
- 2 Pressure gauge
- 3 Filter
- 4 Governor
- 5a Low pressure protection device
- 5b Maximum gas pressure switch
- 6 1st safety shut-off device
- 7 2nd safety shut-off device
- 8 Ignition device
- 15 Valve leak detection control system
- L Gas train (supplied separately)
- L1 Responsibility of the installer
- L2 Burner
- M1 Pressure test point
- M2 Pressure test point
- M3 Pressure test point

4.12.2 Gas train

Approved according to standard EN 676 and provided separately from the burner.



Make sure that the gas train is properly installed by checking for any fuel leaks.

4.12.3 Gas train installation



DANGER

Disconnect the electrical power using the main switch.



Check that there are no gas leaks.



Pay attention when handling the train: danger of crushing of limbs.



The operator must use the required equipment during installation.

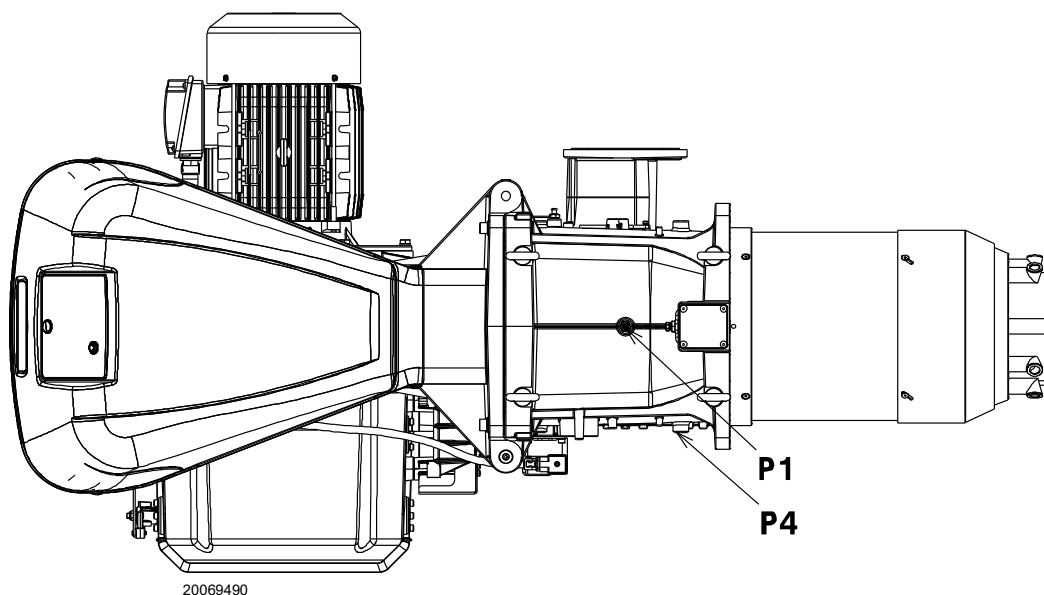

Fig. 19

4.12.4 Gas pressure

Tab. L indicates the minimum pressure drops along the gas supply line, depending on the maximum burner output.

The values shown in Tab. L refer to:

- Natural gas G 20 NCV 9.45 kWh/Sm³ (8.2 Mcal/Sm³)

Column 1

Combustion head pressure drop.

Gas pressure measured at the test point P1)(Fig. 19), with:

- Combustion chamber at 0 mbar;
- Burner working at maximum output;
- Combustion head adjusted as in page 20.

Column 2

Pressure loss at gas butterfly valve 14)(Fig. 4 on page 11) with maximum opening: 90°.

Calculate the approximate maximum output of the burner in this way:

- subtract the combustion chamber pressure from the gas pressure measured at test point P1)(Fig. 19).
- Find, in the table Tab. L related to the burner concerned, the pressure value closest to the result of the subtraction.
- Read the corresponding output on the left.

Example RS 410/EV FGR with G20 natural gas:

Maximum output operation

$$\begin{aligned} \text{Gas pressure at test point P1)(Fig. 19)} &= 25.0 \text{ mbar} \\ \text{Pressure in combustion chamber} &= 5 \text{ mbar} \\ 25.0 - 5 &= 20.0 \text{ mbar} \end{aligned}$$

A pressure of 20.0 mbar, column 1, corresponds in the table Tab. L to an output of 2745 kW.

This value serves as a rough guide; the effective output must be measured at the gas meter.

To calculate the required gas pressure at test point P1)(Fig. 19), set the MAX output required from the burner operation:

- find the nearest output value in the table Tab. L for the burner in question.
- Read, on the right (column 1), the pressure at the test point P1)(Fig. 19).
- Add this value to the estimated pressure in the combustion chamber.

Example for RS 410/EV FGR with G20 natural gas:

Required burner maximum output operation: 2745 kW

$$\begin{aligned} \text{Gas pressure at an output of 2745 kW} &= 20.0 \text{ mbar} \\ \text{Pressure in combustion chamber} &= 5 \text{ mbar} \\ 20.0 + 5 &= 25.0 \text{ mbar} \end{aligned}$$

Pressure required at test point P1)(Fig. 19).



The heat output and gas pressure data in the head refer to operation with gas butterfly valve fully open (90°).

	kW	1 Δp (mbar)	2 Δp (mbar)
	G 20		
RS 410/EV FGR	595	2	0.3
	953	4	0.5
	1312	6	0.7
	1670	9	1
	2028	12	1.3
	2387	15	1.7
	2745	20	2.2
	3103	25	2.7
	3462	31	3.3
	3820	38	4
RS 510/EV FGR	660	3	0
	1120	6	0.1
	1580	9	0.3
	2040	13	0.5
	2500	18	0.9
	2960	24	1.4
	3420	31	2.1
	3880	39	3
	4340	49	4.1
	4800	60	5.4
RS 610/EV FGR	912	2	0
	1461	4	0
	2009	6	0.1
	2558	10	0.3
	3107	14	0.8
	3655	19	1.6
	4204	25	2.4
	4753	32	3.2
	5301	40	4
	5850	49	4.6

Tab. L

4.13 Electrical wiring

Notes on safety for the electrical wiring



DANGER

- The electrical wiring must be carried out with the electrical supply disconnected.
- Electrical wiring must be made in accordance with the regulations currently in force in the country of destination and by qualified personnel. Refer to the wiring diagrams.
- The manufacturer declines all responsibility for modifications or connections different from those shown in the wiring diagrams.
- Check that the electrical supply of the burner corresponds to that shown on the identification label and in this manual.
- The burners equipped with LMV5... can operate in FS1 or FS2 mode. See specific manual LMV5... for continuous/intermittent operation. Refer to the following notes for the type of operation that has been set.
- The FS1 burners have been set for intermittent operation. This means that the burner should compulsorily be stopped at least once every 24 hours to enable the flame control to check its own safety and efficiency at start-up. Normally the boiler's thermostat/pressure switch ensures that the burner stops. If this is not the case, a time switch should be fitted in series to TL to stop the FS1 burner at least once every 24 hours. Refer to the wiring diagrams.
- The FS2 burners have been set for continuous operation. This means that the burner should compulsorily be stopped at least once every 72 hours to enable the flame control to check its own safety and efficiency at start-up. Normally, burner stopping is guaranteed by the boiler's thermostat/pressure switch. If this is not the case, a time switch should be fitted in series to TL to stop the FS2 burner at least once every 72 hours. Refer to the wiring diagrams.
- The electrical safety of the device is obtained only when it is correctly connected to an efficient earthing system, made according to current standards. It is necessary to check this fundamental safety requirement. In the event of doubt, have the electrical system checked by qualified personnel. Do not use the gas tubes as an earthing system for electrical devices.
- The electrical system must be suitable for the maximum power absorption of the device, as indicated on the label and in the manual, checking in particular that the section of the cables is suitable for that level of power absorption.
- For the main power supply of the device from the electricity mains:
 - do not use adapters, multiple sockets or extensions;
 - use a multiple pole switch with at least a 3 mm gap between the contacts (overvoltage category III), as envisaged by the present safety standards.
- Do not touch the device with wet or damp body parts and/or in bare feet.
- Do not pull the electric cables.
- Check the electric wiring inside the boiler complies with the national and local safety regulations.
- Live and neutral should not be mixed up (this could cause dangerous malfunctions, a loss of protection against electric shocks, etc..).
- Make sure the cable grommets of the connected cables comply with the relevant standards (e.g. EN60730 and EN60 335).
- When wiring the unit, make sure that AC 230V mains voltage cables are run strictly separate from extra low-voltage cables to avoid risks of electrical shock hazard.

Before carrying out any maintenance, cleaning or checking operations:



DANGER

Disconnect the electrical supply from the burner by means of the main system switch.



DANGER

Turn off the fuel interception tap.



DANGER

Avoid condensate, ice and water leaks from forming.

If the cover is still present, remove it and proceed with the electrical wiring according to the wiring diagrams.

Use flexible cables in compliance with the EN 60 335-1 standard.

4.13.1 Supply cables and external connections passage

All the cables to be connected to the burner must be threaded through cable grommets. The use of the cable grommets can take various forms; by way of example see Fig. 20.

Key (Fig. 20)

- 1 Electrical supply - Bore for M32
- 2 Consents and safety devices - Bore for M20
- 3 Minimum gas pressure switch - Bore for M20
- 4 VPS gas valve leak detection control kit- Bore for M20
- 5 Gas train - Bore for M20
- 6 Available - Bore for M20
- 7 Available - Bore for M16

Cable grommets used in the factory:

- A Fan motor
- B Maximum gas pressure switch
- C ServomotorS
- D Rpm sensor

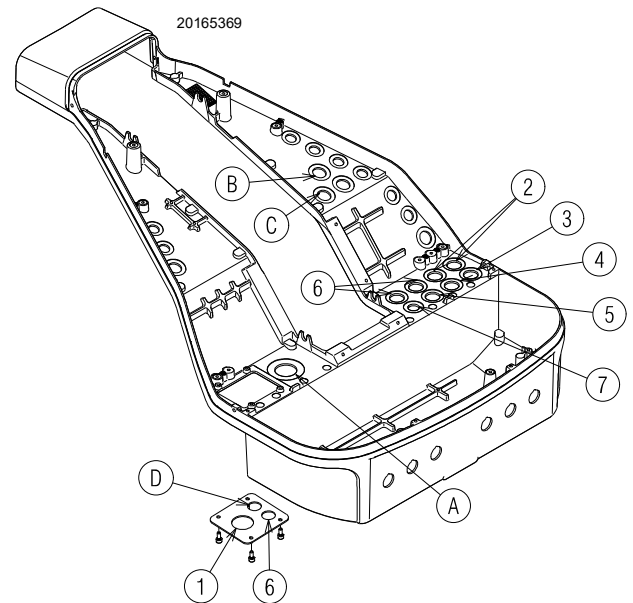

Fig. 20



After carrying out maintenance, cleaning or checking operations, reassemble the cover and all the safety and protection devices of the burner.

5 Start-up, calibration and operation of the burner

5.1 Notes on safety for the first start-up



The first start-up of the burner must be carried out by qualified personnel, as indicated in this manual and in compliance with the standards and regulations of the laws in force.



Check the correct working of the adjustment, command and safety devices.



Refer to paragraph "Safety test - with gas ball valve closed" on page 33 before the first start-up.

5.2 Adjustments prior to ignition

Combustion head adjustment has already been already described in the section "Combustion head adjustment" on page 20.

In addition, the following adjustments must also be made:

- open manual valves upstream from the gas train.
- Adjust the minimum gas pressure switch to the start of the scale.
- Adjust the maximum gas pressure switch to the end of the scale.
- Adjust the air pressure switch to the start of the scale.
- Adjust the pressure switch for the leak detection control (PVP kit)(Fig. 28 on page 37) according to the instructions supplied with the kit.
- Purge the air from the gas line. We recommend using a plastic tube routed outside the building and to purge air until gas is smelt.
- Fit a U-type pressure gauge or a differential pressure gauge (Fig. 21), with socket (+) on the gas pressure of the pipe coupling and (-) in the combustion chamber. The manometer readings are used to calculate MAX burner output using the Tab. L.
- Connect two lamps or testers to the two gas line solenoids to check the exact moment in which voltage is supplied. This operation is unnecessary if each of the two solenoids is equipped with a pilot light that signals voltage passing through.



Before starting up the burner, it is good practice to adjust the gas train so that ignition takes place in conditions of maximum safety, i.e. with gas delivery at the minimum.

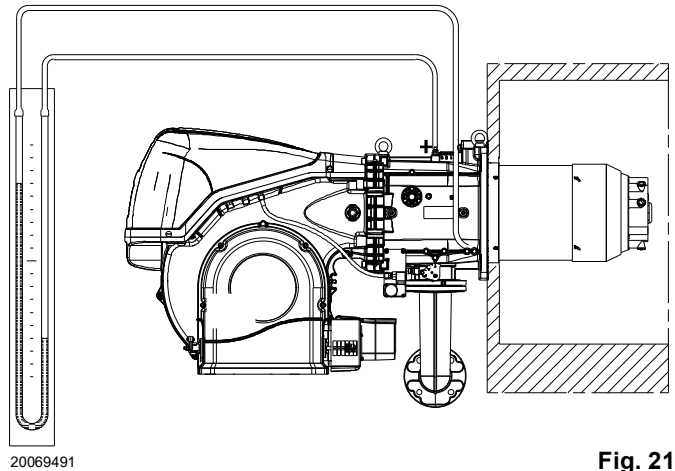

Fig. 21

5.3 Burner start-up

Feed electricity to the burner via the disconnecting switch on the boiler panel.

Close the thermostats/pressure switches.

Turn the switch to position “**AUTO**” (Fig. 22).



Make sure that the lamps or testers connected to the solenoids, or indicator lights on the solenoids themselves, show that no voltage is present. If voltage is present, stop the burner **immediately** and check the electrical wiring. When the burner starts, check the direction of the motor rotation, as indicated in Fig. 22.

As the burner is not fitted with a device to check the sequence of the phases, the motor rotation may be incorrect. As soon as the burner starts up, go in front of the cooling fan of the fan motor and check it is rotating anticlockwise.

If this is not the case:

- place the switch of Fig. 22 in position “**0**” and wait for the flame control to carry out the switch-off phase;
- disconnect the electrical supply from the burner;

invert the phases on the three-phase power supply.

Once the above steps are complete, the burner should light.

If the motor starts up, but the flame does not appear and the flame control goes into lockout, reset it and wait for a new ignition attempt.

If ignition is still not achieved, it may be that gas is not reaching the combustion head within the safety time period of 3 seconds. In this case increase gas ignition delivery.

The arrival of gas at the pipe coupling is indicated by the U-type pressure gauge (Fig. 21).

If further burner lockouts occur, refer to the “Release procedure” given in the equipment manual supplied.



In the event of a burner lockout, more than two consecutive burner reset operations could cause damage to the installation. On the third lockout, contact the Aftersales Service.



If further lockouts or burner faults occur, interventions must only be made by qualified, authorised personnel (as indicated in this manual, and in compliance with the laws and regulations currently in force).

Once the burner has ignited, proceed with the global adjustment of the burner.

Further interfaces and communication functions with computers, for remote control or integration in central supervision systems are available on the basis of the configuration of the system.

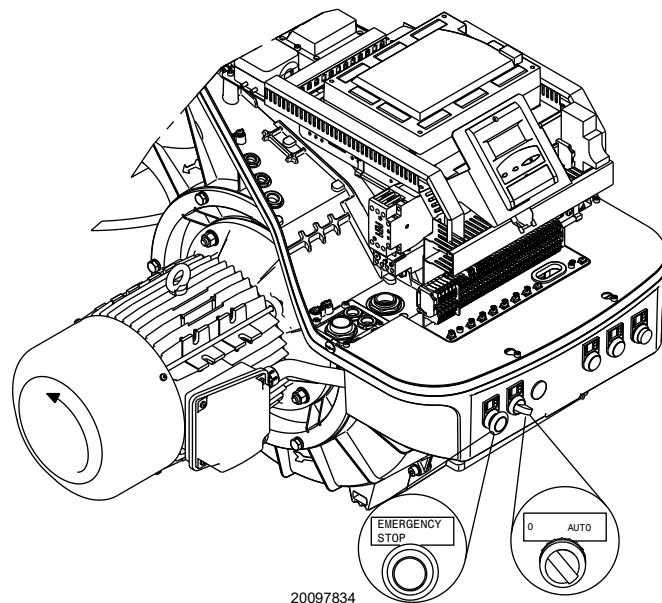

Fig. 22



The first start up and every further internal setting operation of the adjustment system or the expansion of the base functions require access by means of password and are to be carried out by service personnel who are especially trained for the internal programming of the instrument and the specific application created with this burner.

The first start-up and curve synchronisation manual is supplied with the burner.

At request, the complete manual for the control and setting of all parameters is available.

5.4 FGR commissioning

The flue gas recirculation (FGR) function is used to reduce the NOx content of flue gases. This is accomplished by feeding a certain proportion of the flue gas back to the combustion chamber, causing the flame's temperature to drop. The amount of recirculated flue gas is set via auxiliary actuator 3.



When making the setting, it must be observed that excessive amounts of recirculated flue gas can cause the flame to lift off the burner's head (stability limit of flame).

**NOTE:
Reduction of maximum burner output**

Use of the flue gas recirculation (FGR) function or the flue gas mass introduced to the supply air duct might lower the burner's maximum output.

This means that the maximum amount of combustion air that can be introduced will be reduced.

Hence, the amount of fuel for high-fire operation must be reduced to ensure correct combustion values.

The flame control supports flue gas recirculation (FGR) function: flue gas recirculation (FGR) without temperature compensation (operating mode flue gas recirculation (FGR) = time or temperature).

With these operating principles, the positions of auxiliary actuator 3 can only change between CLOSED (ignition position) and the positions on the ratio control curves.

First time set up

Commission the plant with no influence from flue gas recirculation (FGR).

Factory preset: FGR-Mode = AUX3onCurve

Flue gas recirculation (FGR) function is deactivated.

(Auxiliary actuator 3 is driven along its parameterized ratio control curve)

This enables the fuel-air ratio control system to be set as if the plant operated without flue gas recirculation (FGR).

For that purpose, in flue gas recirculation (FGR) mode Time, set the switch-on time to its maximum or parameterize it at such a level that auxiliary actuator 3 will not be positioned until the curve settings become active.

Analogously, in flue gas recirculation (FGR) mode Temperature, set the switch-on temperature to a level that cannot be reached.

After completing the settings of the fuel-air ratio control curves without flue gas recirculation (FGR), the actual settings with an active auxiliary actuator 3 can now be made.

Since this might have an impact on the combustion settings, the fuel- and air-regulating actuators may have to be readjusted.

First time FGR set up

Modify the factory preset: FGR-Mode = time (Auxiliary actuator 3 is held in the ignition position until an adjustable time is reached).

We suggest to use a value from 5-15 minutes for first time FGR commissioning.

Check value of temperature of flue gas recirculation (FGR). It must be 120-130 °C to reduce condensation in burner or intake duct.

Operation FGR set up

Modify the factory preset: FGR-Mode = temperature (Auxiliary actuator 3 is held in the ignition position until an adjustable temperature is reached.).

After first time FGR commissioning, we suggest to use this setting using a temperature sensor in FGR duct.

We suggest to use previous value of temperature measured during first time commissioning.

In case of use the FGR-Mode = time, make sure that the flue gas temperature reaches the value within the set time.

FGR temperature sensor

FGR-Mode: PT 1000 temperature probe is connect to X1 terminal board (see electrical connection)

You can connect 2 probes in X1 terminal board together:

Factory pre-set:

PT100 for boiler temperature (customer installation)

PT1000 for FGR-sensor (already connected)



You can't use PT1000 probe for boiler temperature when it's used as FGR sensor. But you can use other type of connection.



Check air temperature where is mounted flame sensor.

If temperature is more than 50-60°, it's mandatory air cooling using burner air-intake.



While burner is working with FGR, it's possible reach high surface temperature.

5.5 Air / fuel adjustment

Air/fuel synchronisation is carried out with the relevant air and gas servomotors by logging a calibration curve by using the electronic cam.

It is advisable, to reduce the loss and for a wide calibration field, to adjust the servomotors to the maximum of the output used, the nearest possible to the maximum opening (90°).

The choking of the air, taking into account the maximum combustion output, takes place by varying the adjustment of the combustion head (see "Combustion head adjustment" on page 20).

On the gas butterfly valve, the fuel step according to the burner output required, with servomotor completely open, is carried out by the pressure stabiliser on the gas train.

5.5.1 Air adjustment for maximum output

- Adjust the servomotor to maximum opening (nearly 90°) so that the air butterfly valves are entirely open.

5.5.2 Air/fuel adjustment and output modulation system

The air/gas regulator and output modulation system equipping **RS/EV** series burners performs a number of integrated functions to optimise burner function, in both individual installations and in combination with other units (e.g. double furnace boiler or multiple heat generators in parallel).

The basic system functions control:

- 1 The dosage of the air and fuel through positioning using direct servocommands of the relevant valves eliminating the possible play in the calibration systems with mechanical cam lever mechanisms, used on traditional modulating burners.
- 2 The modulation of the burner output in accordance with the load required by the system, with maintenance of the pressure or temperature of the boiler at the operating values set.
- 3 The sequence (cascade adjustment) of more than one boiler through the suitable connection of the various units and the activation of the internal software of the individual systems (option).

Further interfaces and communication functions with computers, for remote control or integration in central supervision systems are available on the basis of the configuration of the system.



WARNING

The first start up and every further internal setting operation of the adjustment system or the expansion of the base functions require access by means of password and are to be carried out by service personnel who are especially trained for the internal programming of the instrument and the specific application created with this burner.

5.5.3 Burner adjustment

The optimum adjustment of the burner requires an analysis of flue gases at the boiler outlet.

Adjust in sequence:

- 1 - Output upon ignition
- 2 - MAX output
- 3 - MIN output
- 4 - Intermediate outputs between Min. and Max.
- 5 - Air pressure switch
- 6 - Maximum gas pressure switch
- 7 - Minimum gas pressure switch

5.5.4 Output upon ignition



WARNING

For safety purposes and correct product operation, the ignition output, if it is adjustable, must be carried out by authorized personnel and in compliance with the standards and regulations of the laws in force.

Air adjustment

The adjustment of the air is carried out by changing the angle of the air damper changing the degrees of the air servomotor inside the electronic cam programme.

5.5.5 Maximum output

The MAX output must be set within the firing rate (Fig. 2 on page 9).

Adjustment of gas delivery

Measure the gas delivery on the gas meter.

As an indicative guide just read the gas pressure on the pressure gauge (shown in Fig. 26 on page 35) and follow the instructions given on page 25.

- If it is necessary to reduce it, lower the output gas pressure via the pressure adjuster located beneath the gas valve.
- If delivery needs to be increased, increase the adjuster outlet gas pressure.

Air adjustment

If necessary vary the degrees of the air servomotor.

5.5.6 Minimum output

The MIN output must be set within the firing rate (Fig. 2 on page 9).

5.6 Final adjustment of the pressure switches

5.6.1 Air pressure switch

Adjust the air pressure switch (Fig. 23) after performing all other burner adjustments with the air pressure switch set to the start of the scale.

With the burner operating at minimum output, insert a combustion analyser in the stack, slowly close the suction inlet of the fan (for example, with a piece of cardboard) until the CO value does not exceed 100 ppm.

Slowly turn the appropriate knob clockwise until the burner goes into lockout.

Check the indication of the arrow pointing upwards on the graduated scale. Turn the knob clockwise again, until the value shown on the scale corresponds with the arrow pointing downwards, and so recovering the hysteresis of the pressure switch shown by the white mark on a blue background, between the two arrows.

Now check the correct start-up of the burner. If the burner locks out again, turn the knob anti-clockwise a little bit more. During these operations it may be useful to measure the air pressure with a pressure gauge.

The connection of the pressure gauge is shown in Fig. 23. The standard configuration is that with the air pressure switch connected in absolute mode. Note the presence of a "T" connection, not supplied.

In certain applications in strong depression situations, the connection of the pressure switch does not allow it to change over. In this case it is necessary to connect the pressure switch in differential mode, applying a second tube between the air pressure switch and the fan suction line mouth.

In this case also, the pressure gauge must be connected in differential mode, as shown in Fig. 23.

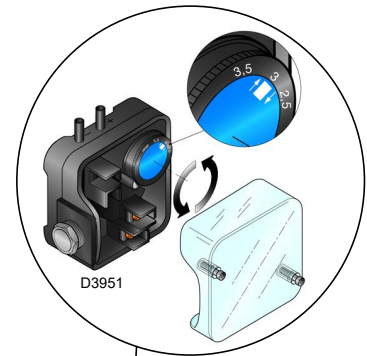

Connection of the pressure gauge with the pressure switch in absolute mode

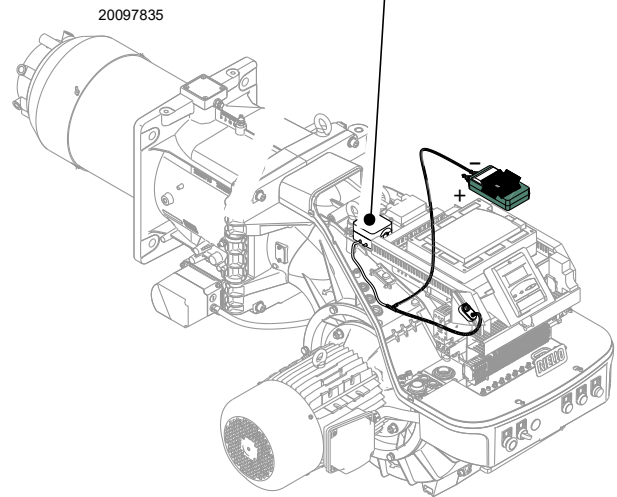

Fig. 23



Connecting the air pressure switch in differential mode, the burner will no longer be certified according to the EN 676 standard.

5.7 Final checks (with burner operating)

<ul style="list-style-type: none"> ➤ Open the thermostat/pressure switch TL ➤ Open the thermostat/pressure switch TS 	➤	The burner must stop
<ul style="list-style-type: none"> ➤ Turn the gas maximum pressure switch knob to the minimum end of scale position ➤ Turn the air pressure switch knob to the maximum end of scale position 	➤	The burner must stop in lockout
<ul style="list-style-type: none"> ➤ Turn off the burner and cut off the power ➤ Disconnect the minimum gas pressure switch connector 	➤	The burner must not start
<ul style="list-style-type: none"> ➤ Darken the flame sensor 	➤	The burner must stop in lockout due to ignition failure

Tab. M



Make sure that the mechanical locking systems on the various adjustment devices are fully tightened.

6 Maintenance

6.1 Notes on safety for the maintenance

The periodic maintenance is essential for the good operation, safety, yield and duration of the burner.

It allows you to reduce consumption and polluting emissions and to keep the product in a reliable state over time.



The maintenance interventions and the calibration of the burner must only be carried out by qualified, authorised personnel, in accordance with the contents of this manual and in compliance with the standards and regulations of current laws.

Before carrying out any maintenance, cleaning or checking operations:



Disconnect the electrical supply from the burner by means of the main system switch.



Turn off the fuel interception tap.



Wait for the components in contact with heat sources to cool down completely.

6.2 Maintenance programme

6.2.1 Maintenance frequency



The gas combustion system should be checked at least once a year by a representative of the manufacturer or another specialised technician.

6.2.2 Safety test - with gas ball valve closed

It is fundamental to ensure the correct execution of the electrical connections between the gas solenoid valves and the burner to perform safely the commissioning.

For this purpose, after checking that the connections have been carried out in accordance with the burner's electrical diagrams, an ignition cycle with closed gas ball valve -dry test- must be performed.

- 1 The manual ball gas valve must be closed
- 2 The electrical contacts of the burner limit switch need to be closed
- 3 Ensures closed the contact of the low gas pressure switch
- 4 Make a trial for burner ignition

The start-up cycle must be as follows:

- Starting the fan for pre-ventilation
- Performing the gas valve seal control, if provided
- Completion of pre-ventilation
- Arrival of the ignition point
- Power supply of the ignition transformer
- Electrical Supply of solenoid gas valves

Since the manual gas ball valve is closed, the burner will not light up and its flame control will go to a safety lockout condition.

The actual electrical supply of the solenoid gas valves can be verified by inserting a tester. Some valves are equipped with light signals (or close/open position indicator) that turn on at the same time as their power supply.



IF THE ELECTRICAL SUPPLY OF THE GAS VALVES OCCURS AT UNEXPECTED TIMES, DO NOT OPEN MANUAL GAS BALL VALVE, SWITCH OFF POWER LINE; CHECK THE WIRES; CORRECT THE ERRORS AND REPEAT THE COMPLETE TEST.

6.2.3 Checking and cleaning



The operator must use the required equipment during maintenance.

Combustion

The optimum calibration of the burner requires an analysis of the flue gases.

Significant differences with respect to the previous measurements indicate the points where most care should be exercised during maintenance.

Combustion head

Open the burner and make sure that all components of the combustion head are in good condition, not deformed by the high temperatures, free of impurities from the surroundings and correctly positioned.

Burner

Check that there are not excess wear or loosen screws.

Clean the outside of the burner.

Fan

Check to make sure that no dust has accumulated inside the fan or on its blades, as this condition will cause a reduction in the air flow rate and provoke polluting combustion.

Boiler

Clean the boiler as indicated in its accompanying instructions in order to maintain all the original combustion characteristics intact, especially the flue gas temperature and combustion chamber pressure.

Gas leaks

Make sure that there are no gas leaks on the pipe between the gas meter and the burner.

Gas filter

Change the gas filter when it is dirty.

Combustion

If the combustion values measured before starting maintenance do not comply with applicable legislation or do not indicate efficient combustion, consult the Tab. N or contact our Technical Support Service to implement the necessary adjustments.

It is advisable to set the burner according to the type of gas used and following the indications in Tab. N.

EN 676		Air excess			
		Max. output. $\lambda \leq 1,2$		Min. output. $\lambda \leq 1,3$	
GAS	CO ₂ theoretical max. 0% O ₂	CO ₂ % Calibration		CO	NO _x
		$\lambda = 1.2$	$\lambda = 1.3$	mg/kWh	mg/kWh
G 20	11.7	9.7	9.0	≤ 100	≤ 170
G 25	11.5	9.5	8.8	≤ 100	≤ 170
G 30	14.0	11.6	10.7	≤ 100	≤ 230
G 31	13.7	11.4	10.5	≤ 100	≤ 230

Tab. N

6.2.4 Safety components

The safety components should be replaced at the end of their life cycle indicated in the following table.

The specified life cycles do not refer to the warranty terms indicated in the delivery or payment conditions.

Safety component	Life cycle
Flame control	10 years or 250,000 operation cycles
Flame sensor	10 years or 250,000 operation cycles
Gas valves (solenoid)	10 years or 250,000 operation cycles
Pressure switches	10 years or 250,000 operation cycles
Pressure adjuster	15 years
Servomotor (electronic cam (if present))	10 years or 250,000 operation cycles
Oil valve (solenoid) (if present)	10 years or 250,000 operation cycles
Oil regulator (if present)	10 years or 250,000 operation cycles
Oil pipes/couplings (metallic) (if present)	10 years
Fan impeller	10 years or 500,000 start-ups

Tab. O

6.2.5 Voltage on the QRI sensor

Minimum value for correct operation: 3.5V DC (value on AZL display at about 50%).

If the value is lower, it could be due to:

- sensor not positioned correctly
- low voltage (lower than 187V)
- bad regulation of the burner

In order to measure, use a voltmeter with a 10V DC scale connected as in the diagram (Fig. 26).

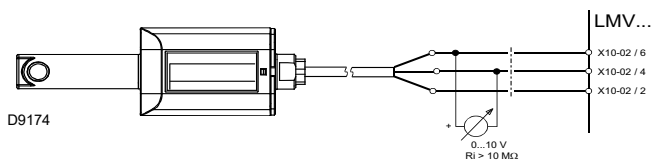

Fig. 24

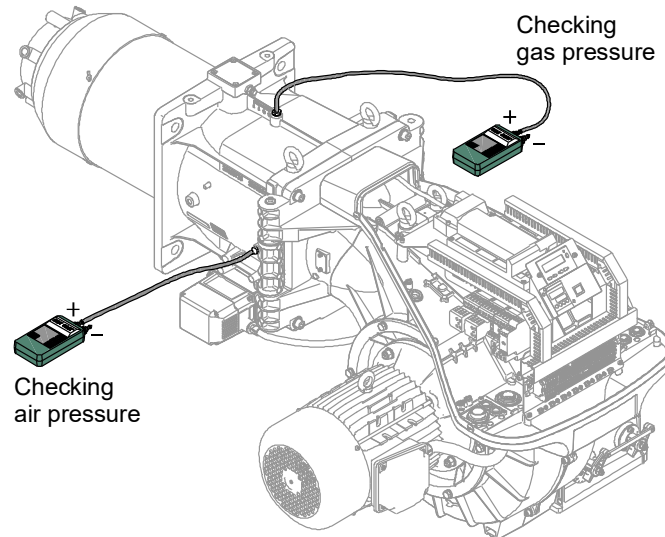

Fig. 26

20076586

6.2.6 Checking the air and gas pressure on the combustion head

To carry out this operation it is necessary to use a pressure gauge to measure the air and gas pressure at the combustion head, as shown in Fig. 26.

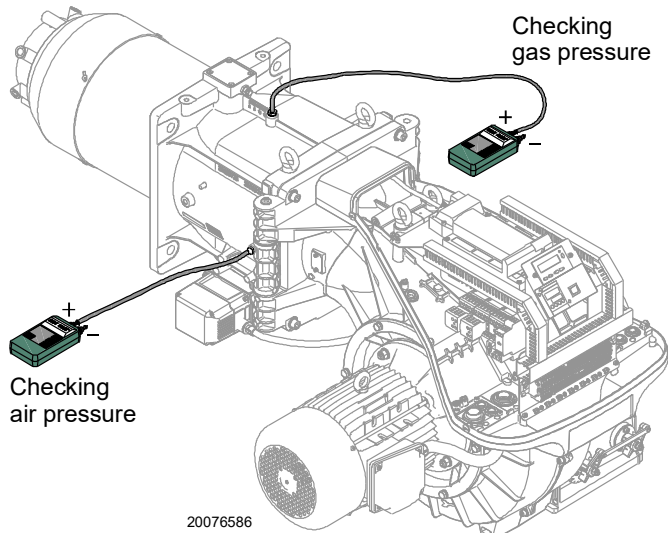

Fig. 25

20076586

6.2.7 Checking the air and gas pressure on the combustion head

To carry out this operation it is necessary to use a pressure gauge to measure the air and gas pressure at the combustion head, as shown in Fig. 26.

6.3 Checking the position of the rpm sensor

To calibrate the rpm sensor 6)(Fig. 27), proceed as follows:

- remove the cover 1) unscrewing the screws 2);
- unscrew or screw the nuts 3) - 5) and the rpm detection disc 4) so that its distance from the rpm sensor 6) is about 2 mm.;
- place the plate 4) on the nut 5) and fix with the lock nut 3);
- close the cover 1) by screwing the screws 2).

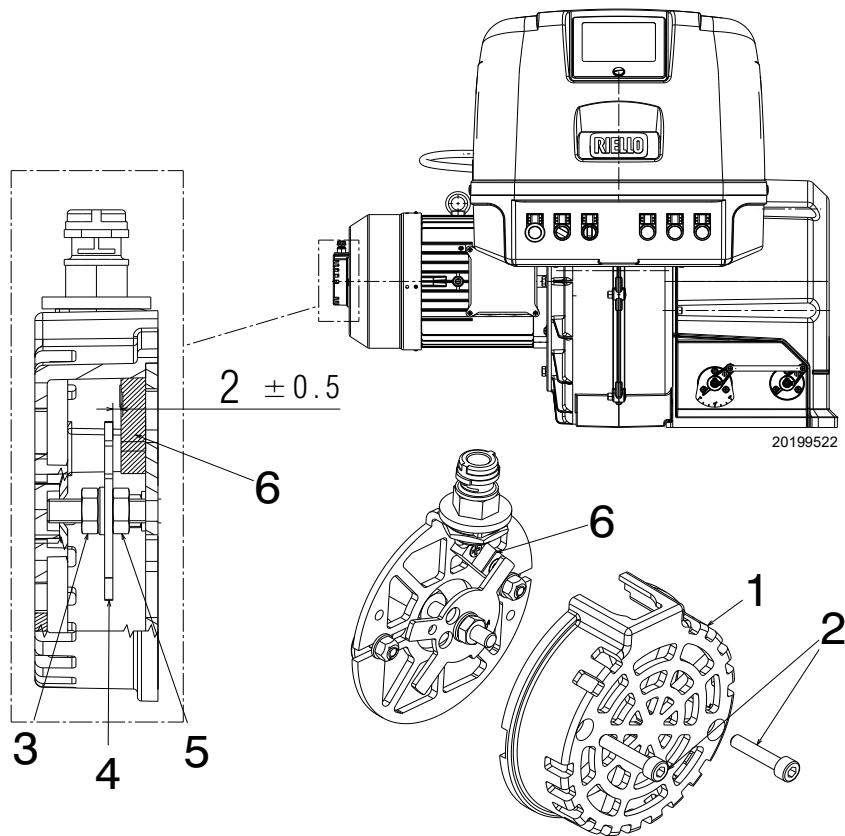

Key (Fig. 27)

- 1 Cover
- 2 Screws for cover fixing
- 3 Lock nut
- 4 Rpm detection disc
- 5 Lower nut
- 6 Rpm sensor

Fig. 27

6.4 Opening the burner



Disconnect the electrical supply from the burner by means of the main system switch.



Turn off the fuel interception tap.



Wait for the components in contact with heat sources to cool down completely.

To open the burner, use the same procedure set out in “Access to head internal part” on page 18.

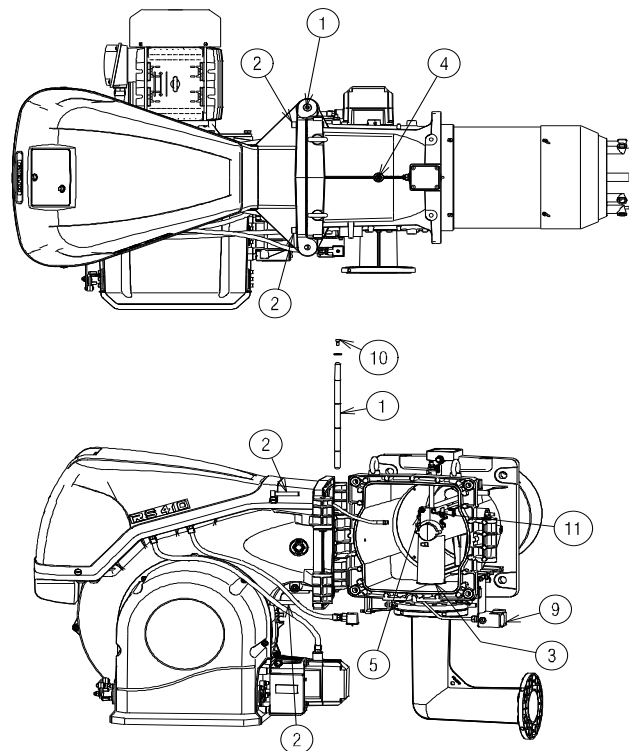

Fig. 28

6.5 Closing the burner

Refit following the steps described but in reverse order; refit all burner components as they were originally assembled.



After carrying out maintenance, cleaning or checking operations, reassemble the cover and all the safety and protection devices of the burner.

7 **Faults - Probable causes - Solutions**

If faults arise in ignition or operations, the burner performs a “safety stop”, which is signalled by the red burner lockout LED.

The display visualises alternately the lockout code and the relative diagnostic. To reset the start-up conditions, refer to the “Reset procedure” indicated in the flame control manual supplied.

When the burner starts again, the red LED goes out and the flame control is reset.

**WARNING**

In the event of a burner lockout, more than two consecutive burner reset operations could cause damage to the installation. On the third lockout, contact the Aftersales Service.

**DANGER**

If further lockouts or burner faults occur, interventions must only be made by qualified, authorised personnel (as indicated in this manual, and in compliance with the laws and regulations currently in force).

A Appendix - Accessories**Kit for modulating operation**

Burner	Probe	Adjustment field	Code
All models	PT 100 temperature	- 100...+ 500°C	3010110
All models	4 - 20 mA pressure	0...2.5 bar	3010213
All models	4 - 20 mA pressure	0...16 bar	3010214
All models	4 - 20 mA pressure	0...25 bar	3090873

Inverterkit (VSD)

Burner	Line voltage	Motor Output (kW)	Inverter Output (kW)	Code
RS 410/EV FGR	400V	9.2	11	20163093
RS 510/EV FGR	400V	12	15	20163096
RS 610/EV FGR	400V	15	15	20163096

**WARNING**

The use of inverters other than those indicated by the manufacturer may lead to burner failure and, in extreme cases, a potential risk of harm to people and damage to property.

The manufacturing company shall not be liable for any such damage arising from non-observance of the requirements contained in this manual.

Soundproofing box kit

Burner	Type	dB(A)	Code
All models	C7	10	3010376

Software interface kit

Burner	Code
All models	3010388

O₂ KIT (external)

Burner	Code
All models	20045187

PVP kit (Seal control function - See gas train booklet)

Burner	Ramp type	Code
All models	MB - CB	3010344

Gas trains in compliance with EN 676

Please refer to manual.

**WARNING**

The installer is responsible for the addition of any safety device not foreseen in this manual.

B Appendix - Electrical panel layout

1	Index of layouts
2	Indication of references
3	Single-wire output layout
4	Functional layout
5	Functional layout LMV 51...
6	Functional layout LMV 51...
7	Functional layout LMV 51...
8	Functional layout LMV 51...
9	Functional layout LMV 51...
10	Functional layout LMV 51...
11	Functional layout LMV 51...
12	Electrical connections set by installer
13	Electrical connections set by installer
14	Electrical connections set by installer

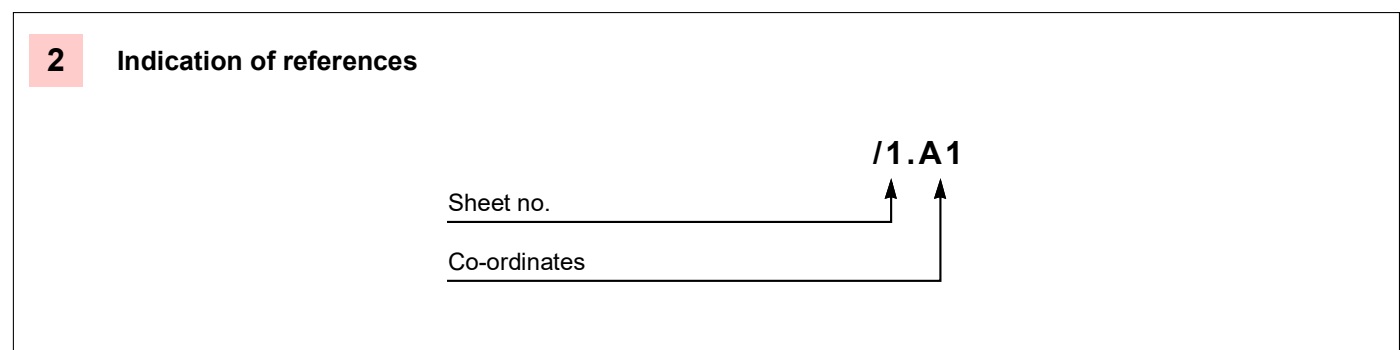

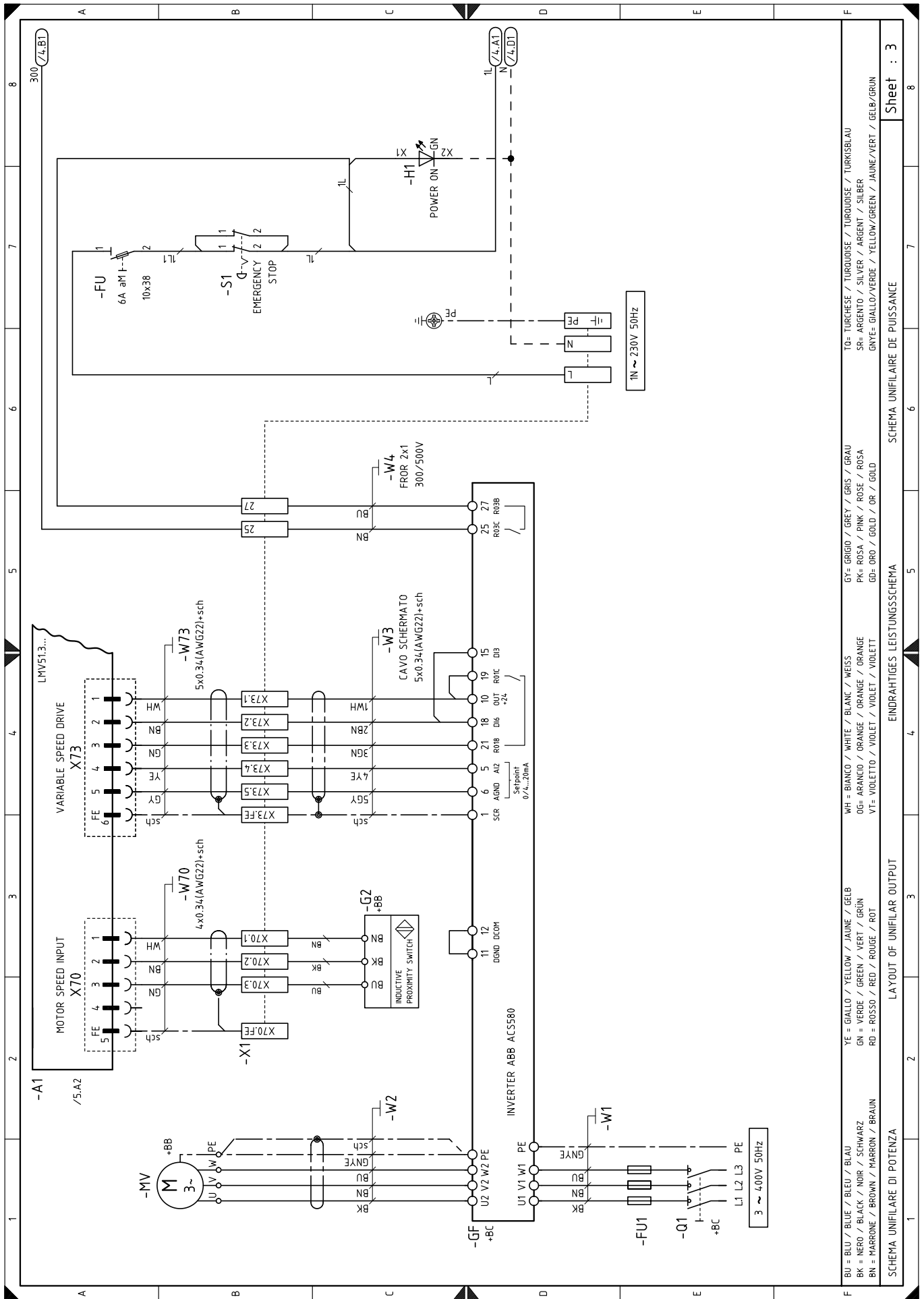

TO= TURCHESE / TURQUOISE / TURQUOISE / TURKUISE / TURKISBLAU
 SR= ARGENTO / SILVER / ARGENT / SILBER
 GNYE= GIALLO/VERDE / YELLOW/GREEN / JAUNE/VERT / GELB/GRUN

GY= GRIGIO / GREY / GRIS / GRAU
 WH= BIANCO / WHITE / BLANC / WEISS
 OG= ARANCIO / ORANGE / ORANGE / ORANGE
 VT= VIOLETTO / VIOLET / VIOLET / VIOLETT

YE = GIALLO / BLUE / BLEU / BLAU
 BK = NERO / BLACK / NOIR / SCHWARZ
 BN = MARRONE / BROWN / MARRON / BRAUN

SCHEMA UNIFILARE DI POTENZA SCHEMA UNIFILAIRE DE PUISSANCE
 EINDRAHTIGES LEISTUNGSSCHEMA LAYOUT OF UNIFILAR OUTPUT

Sheet : 3

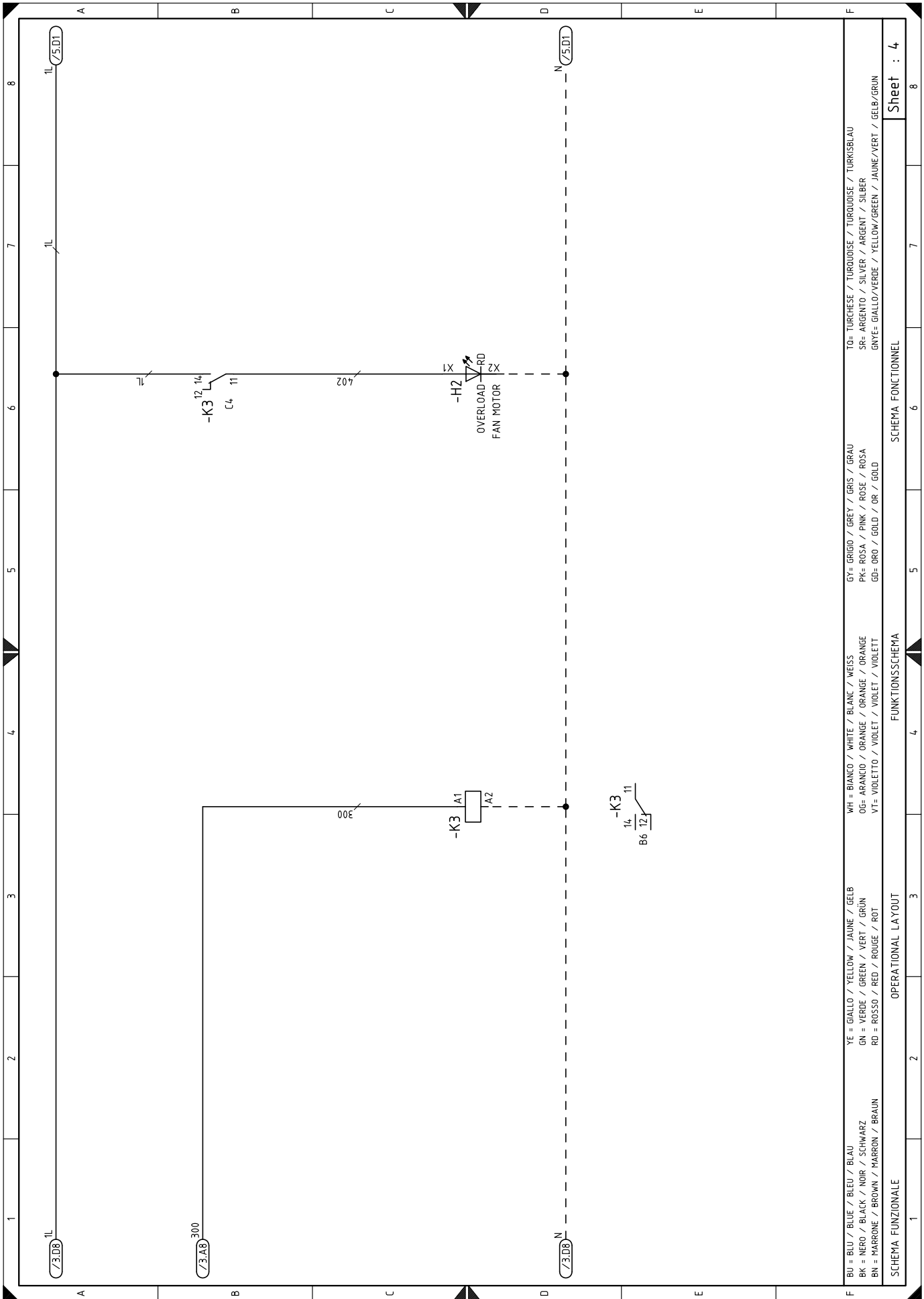

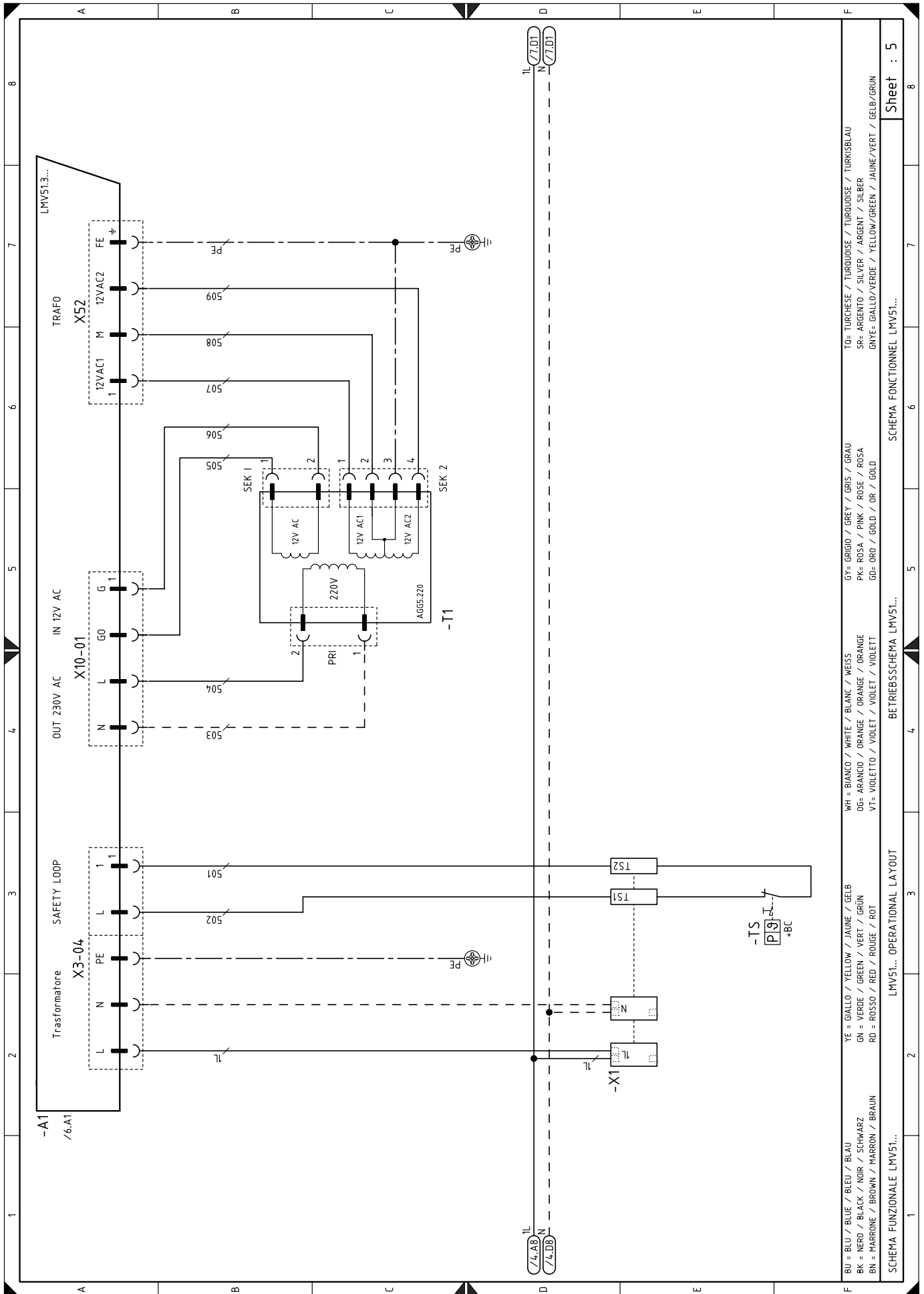

TO= TURCHESE / TURQUOISE / TURQUOISE / TURKISBLAU
 SR= ARGENTO / SILVER / ARGENT / SILBER
 GNYE= GIALLO/VERDE / YELLOW/GREEN / JAUNE/VERT / GELB/GRUN

GY= GRIGIO / GREY / GRIS / GRAU
 PK= ROSA / PINK / ROSE / ROSA
 GD= ORO / GOLD / OR / GOLD

WH = BIANCO / WHITE / BLANC / WEISS
 OG= ARANCIO / ORANGE / ORANGE / ORANGE
 VT= VIOLETTO / VIOLET / VIOLET / VIOLETT

YE = GIALLO / YELLOW / JAUNE / GELB
 GN = VERDE / GREEN / VERT / GRÜN
 RD = ROSSO / RED / ROUGE / ROT

BU = BLU / BLUE / BLEU / BLAU
 BK = NERO / BLACK / NOIR / SCHWARZ
 BN = MARRONE / BROWN / MARRON / BRAUN

SCHEMA FUNZIONALE LMV51...
 LMV51... OPERATIONAL LAYOUT
 SCHEMA FONCTIONNEL LMV51...
 BETRIEBSSCHEMA LMV51...

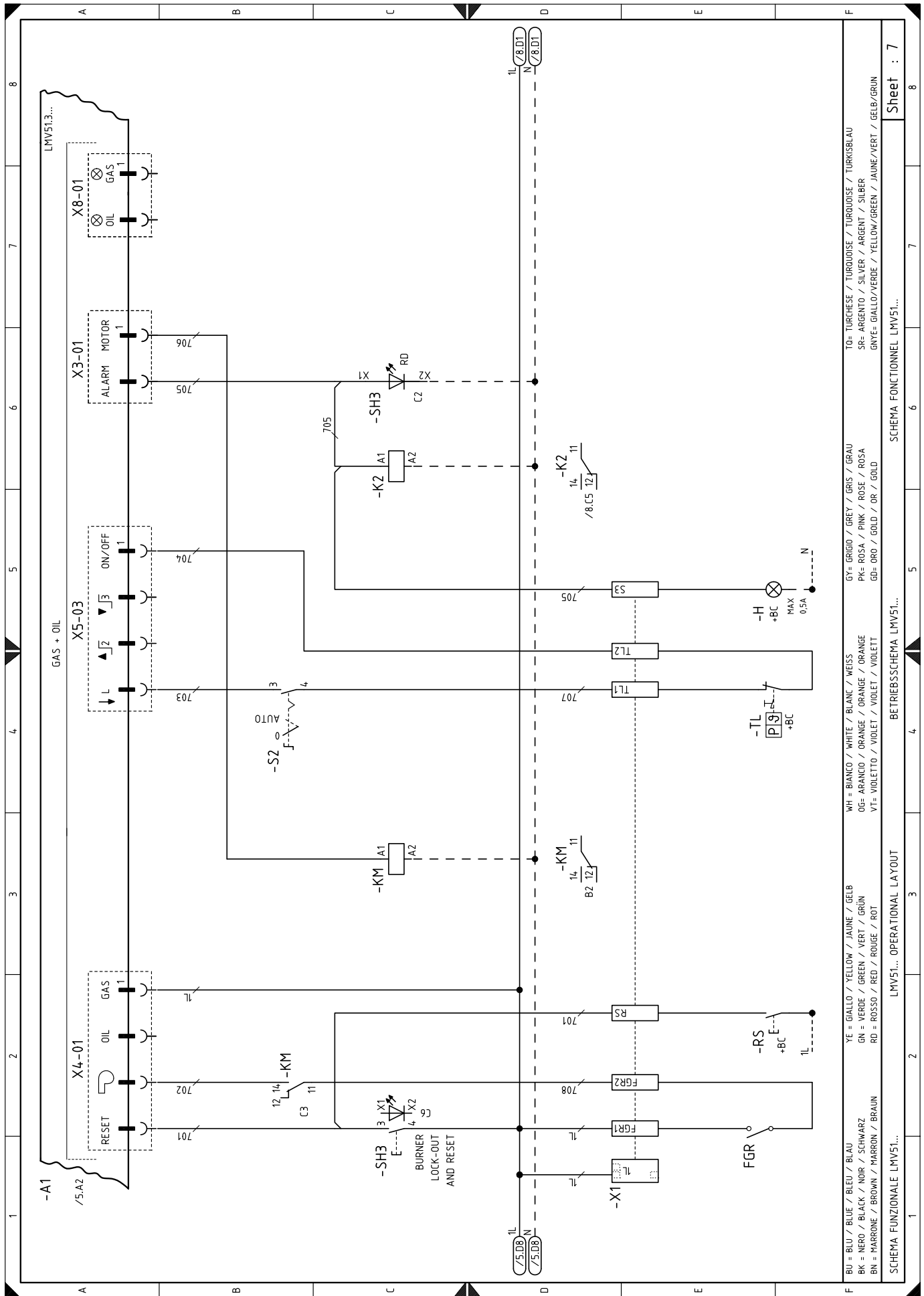

BU = BLU / BLUE / BLEU / BLAU
 BK = NERO / BLACK / NOIR / SCHWARZ
 BN = MARRONE / BROWN / MARRON / BRAUN
 YE = GIALLO / YELLOW / JAUNE / GELB
 GN = VERDE / GREEN / VERT / GRÜN
 RD = ROSSO / RED / ROUGE / ROT
 WH = BIANCO / WHITE / BLANC / WEISS
 OG = ARANCIO / ORANGE / ORANGE / ORANGE
 VT = VIOLETTO / VIOLET / VIOLET / VIOLETT
 GY = GRIGIO / GREY / GRIS / GRAU
 PK = ROSA / PINK / ROSE / ROSA
 GD = ORO / GOLD / OR / GOLD
 TO = TURCHESE / TURQUOISE / TURQUOISE / TURKISBLAU
 SR = ARGENTO / SILVER / ARGENT / SILBER
 GW = GIALLO/VERDE / YELLOW/GREEN / JAUNE/VERT / GELB/GRÜN

SCHEMA FUNZIONALE LMV51...
 LMV51... OPERATIONAL LAYOUT
 BETRIEBSSCHEMA LMV51...
 SCHEMA FONCTIONNEL LMV51...

Sheet : 7

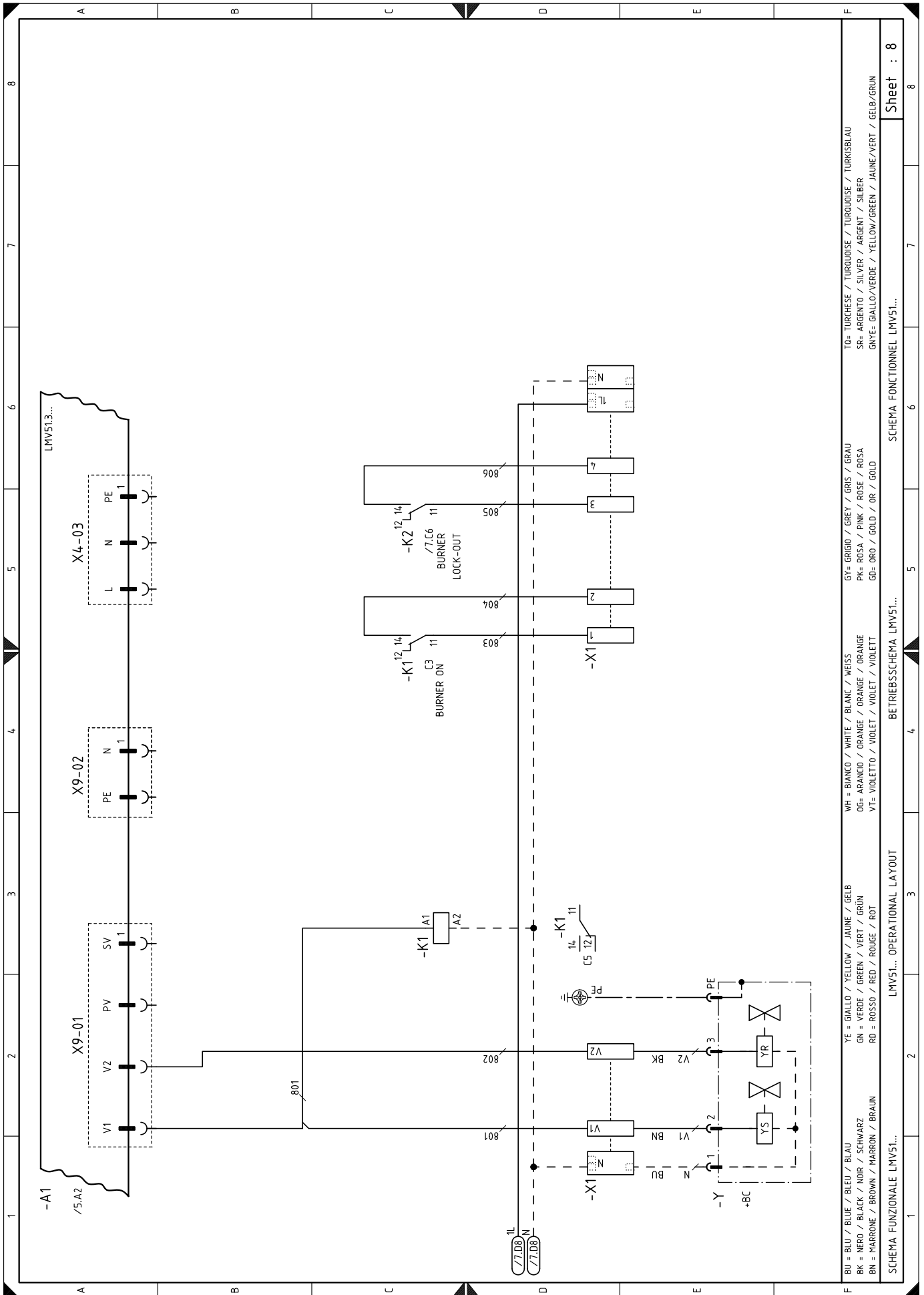

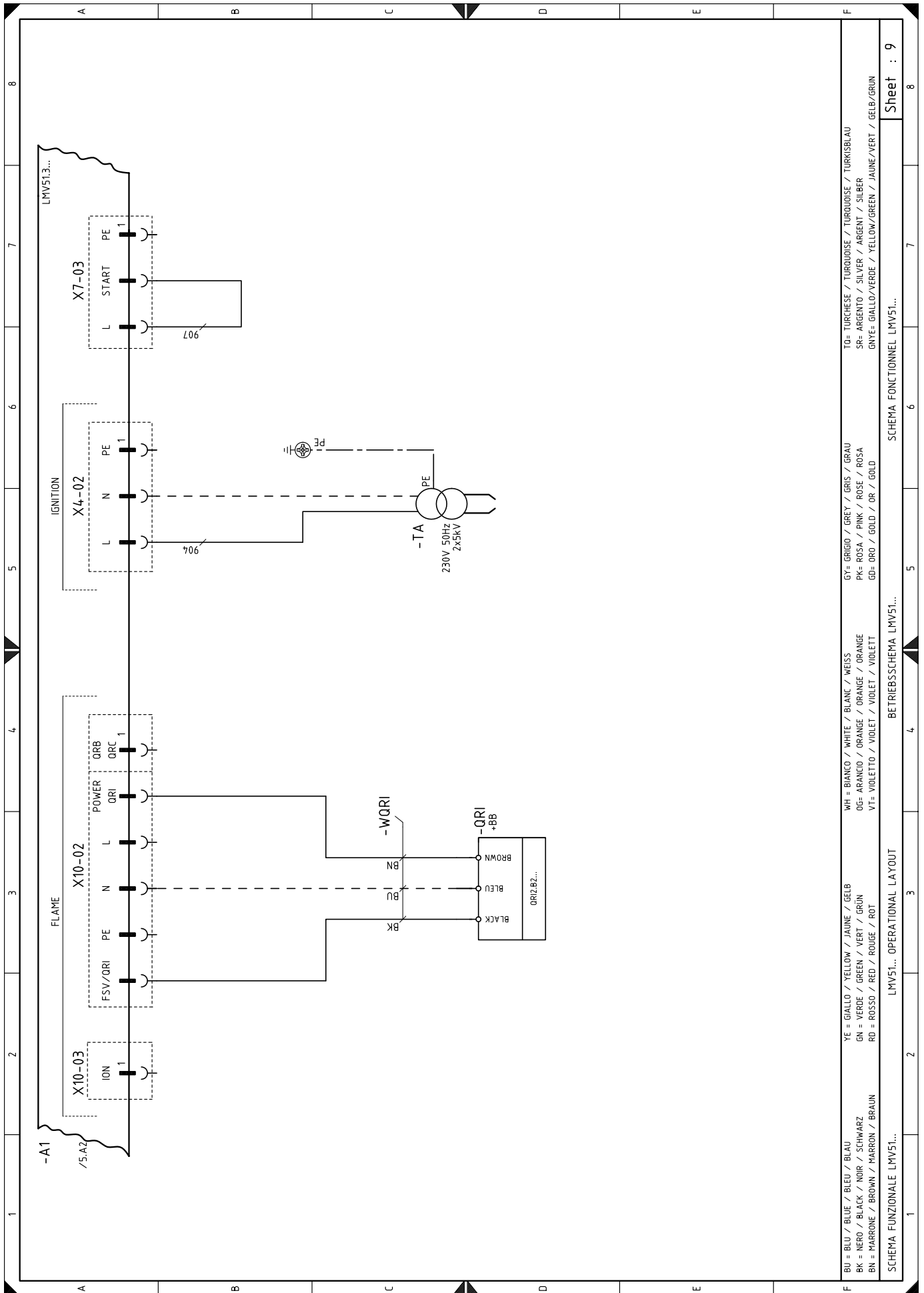

BU = BLEU / BLUE / BLEU / BLAU
 BK = NERO / BLACK / NOIR / SCHWARZ
 BN = MARRONE / BROWN / MARRON / BRAUN
 YE = GIALLO / YELLOW / JAUNE / GELB
 GN = VERDE / GREEN / VERT / GRÜN
 RD = ROSSO / RED / ROUGE / ROT
 WH = BIANCO / WHITE / BLANC / WEISS
 OG = ARANCIO / ORANGE / ORANGE / ORANGE
 VT = VIOLETTO / VIOLET / VIOLET / VIOLETT
 GY = GRIGIO / GREY / GRIS / GRAU
 PK = ROSA / PINK / ROSE / ROSA
 GD = ORO / GOLD / OR / GOLD
 TO = TURCHESE / TURQUOISE / TURQUOISE / TURKISBLAU
 SR = ARGENTO / SILVER / ARGENT / SILBER
 GNYE = GIALLO/VERDE / YELLOW/GREEN / JAUNE/VERT / GELB/GRÜN

SCHEMA FUNZIONALE LMV51...
 LMV51... OPERATIONAL LAYOUT
 BETREIBSSCHEMA LMV51...
 SCHEMA FONCTIONNEL LMV51...
 Sheet : 9

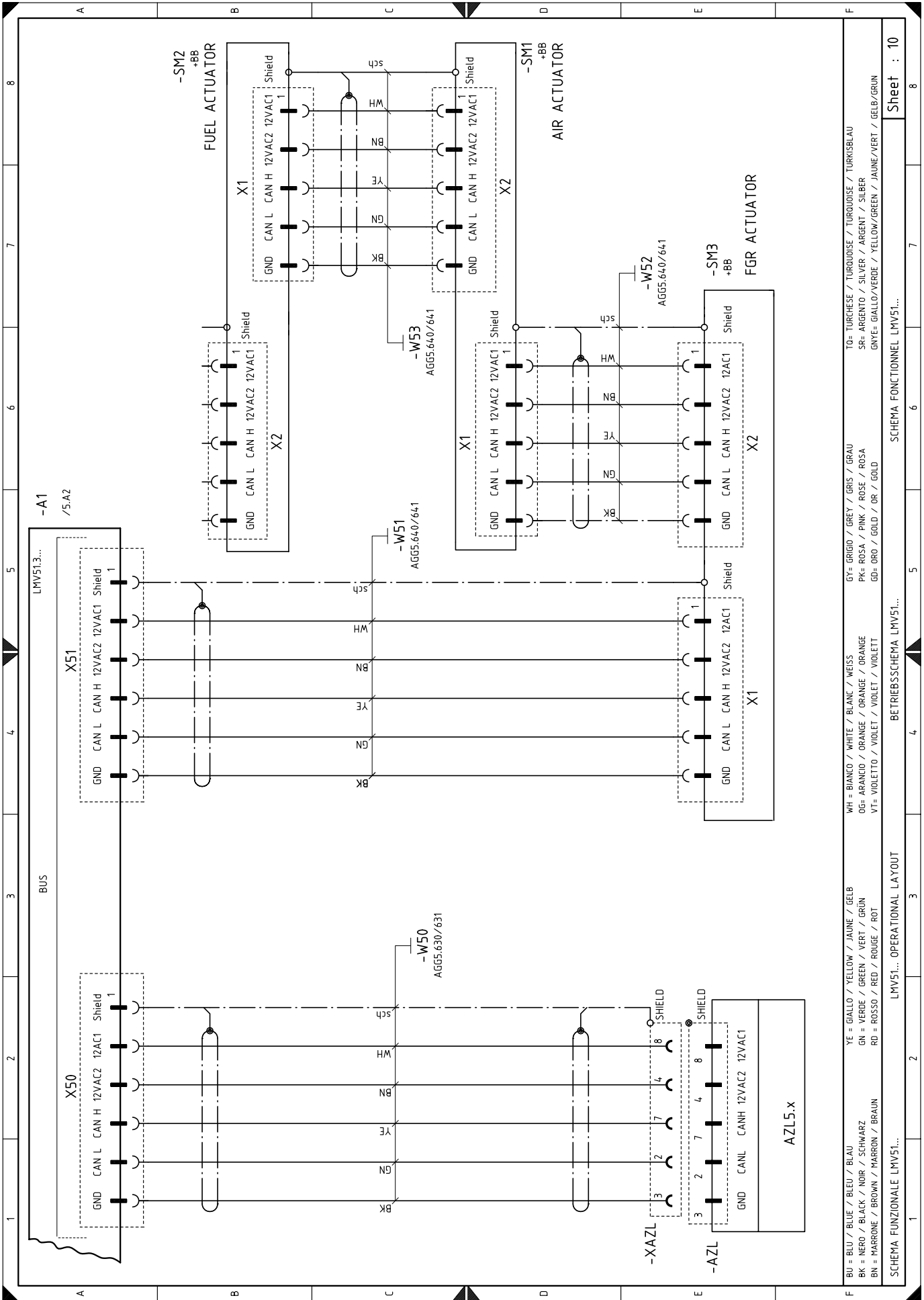

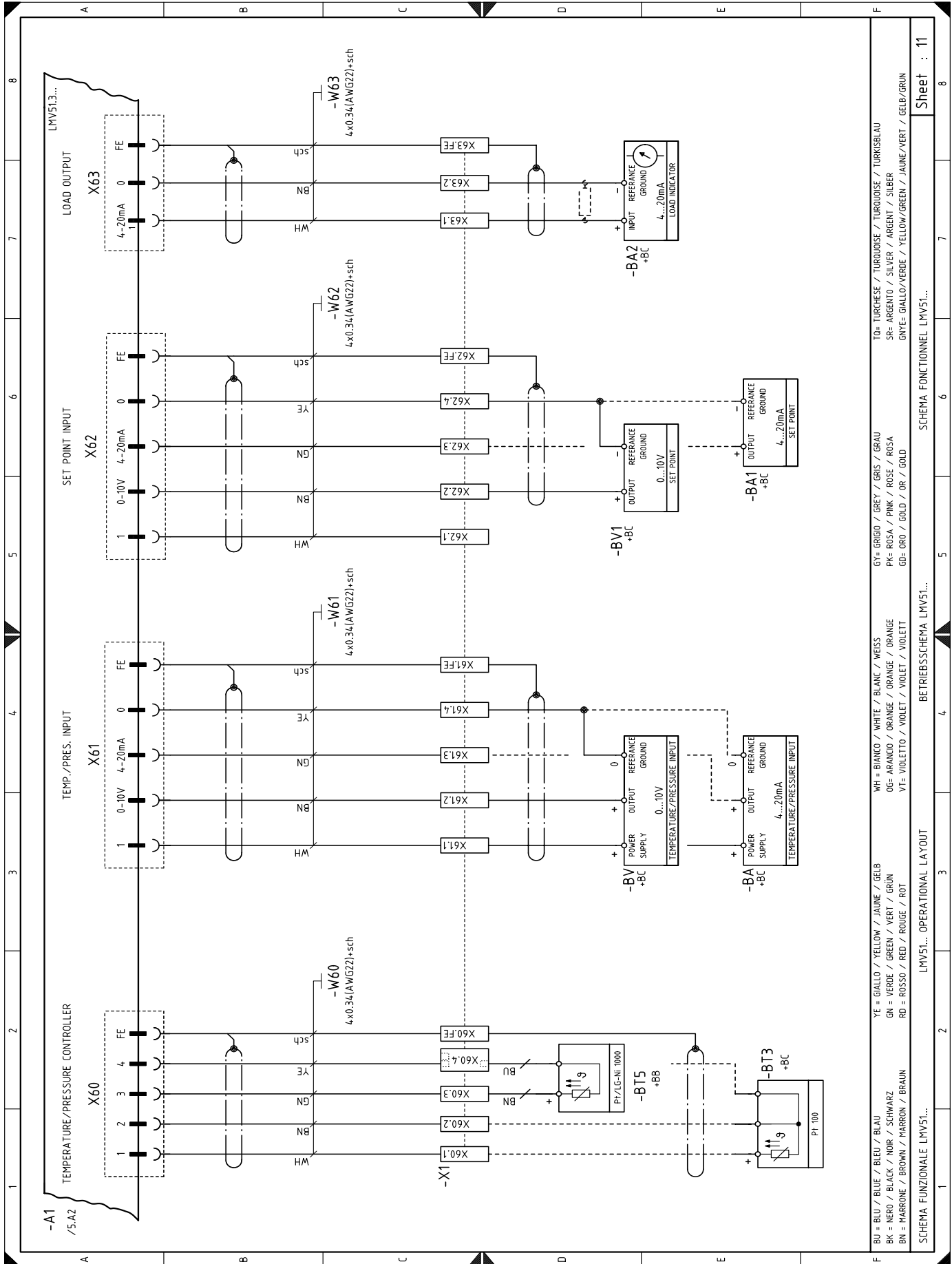

TO= TURCHESE / TURQUOISE / TURQUOISE / TURKISBLAU
 SR= ARGENTO / SILVER / ARGENT / SILBER
 GNYE= GIALLO/VERDE / YELLOW/GREEN / JAUNE/VERT / GELB/GRÜN

GY= GRIGIO / GREY / GRIS / GRAU
 PK= ROSA / PINK / ROSE / ROSA
 GD= ORO / GOLD / OR / GOLD

WH = BIANCO / WHITE / BLANK / WEISS
 OC= ARANCIO / ORANGE / ORANGE / ORANGE
 VT= VIOLETTO / VIOLET / VIOLET / VIOLETT

YE = GIALLO / YELLOW / JAUNE / GELB
 GN = VERDE / GREEN / VERT / GRÜN
 RD = ROSSO / RED / ROUGE / ROT

BU = BLU / BLUE / BLEU / BLAU
 BK = NERO / BLACK / NOIR / SCHWARZ
 BN = MARRONE / BROWN / MARRON / BRAUN

LMV51... OPERATIONAL LAYOUT

BETRIEBSSSCHEMA LMV51...

SCHEMA FONCTIONNEL LMV51...

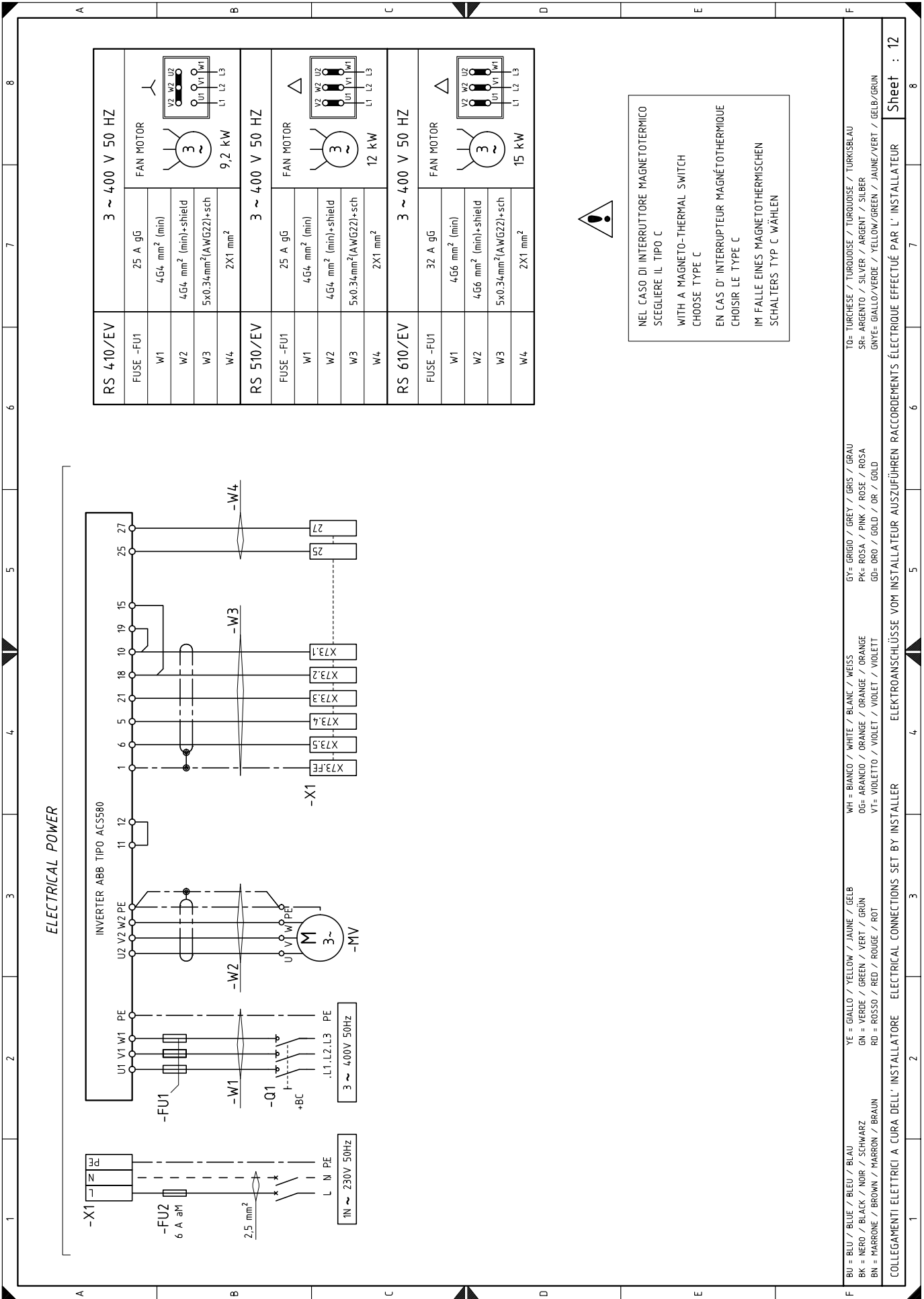

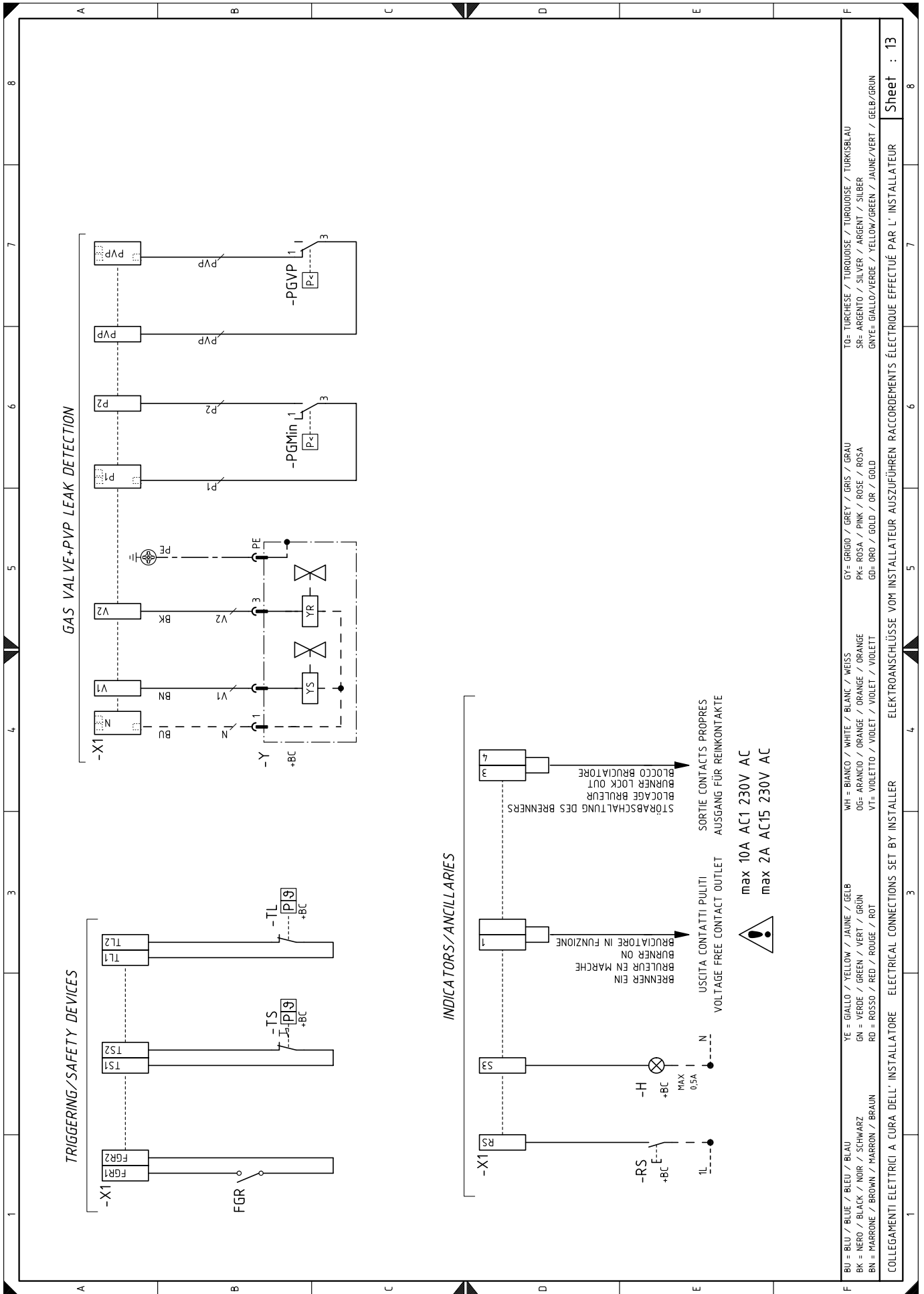

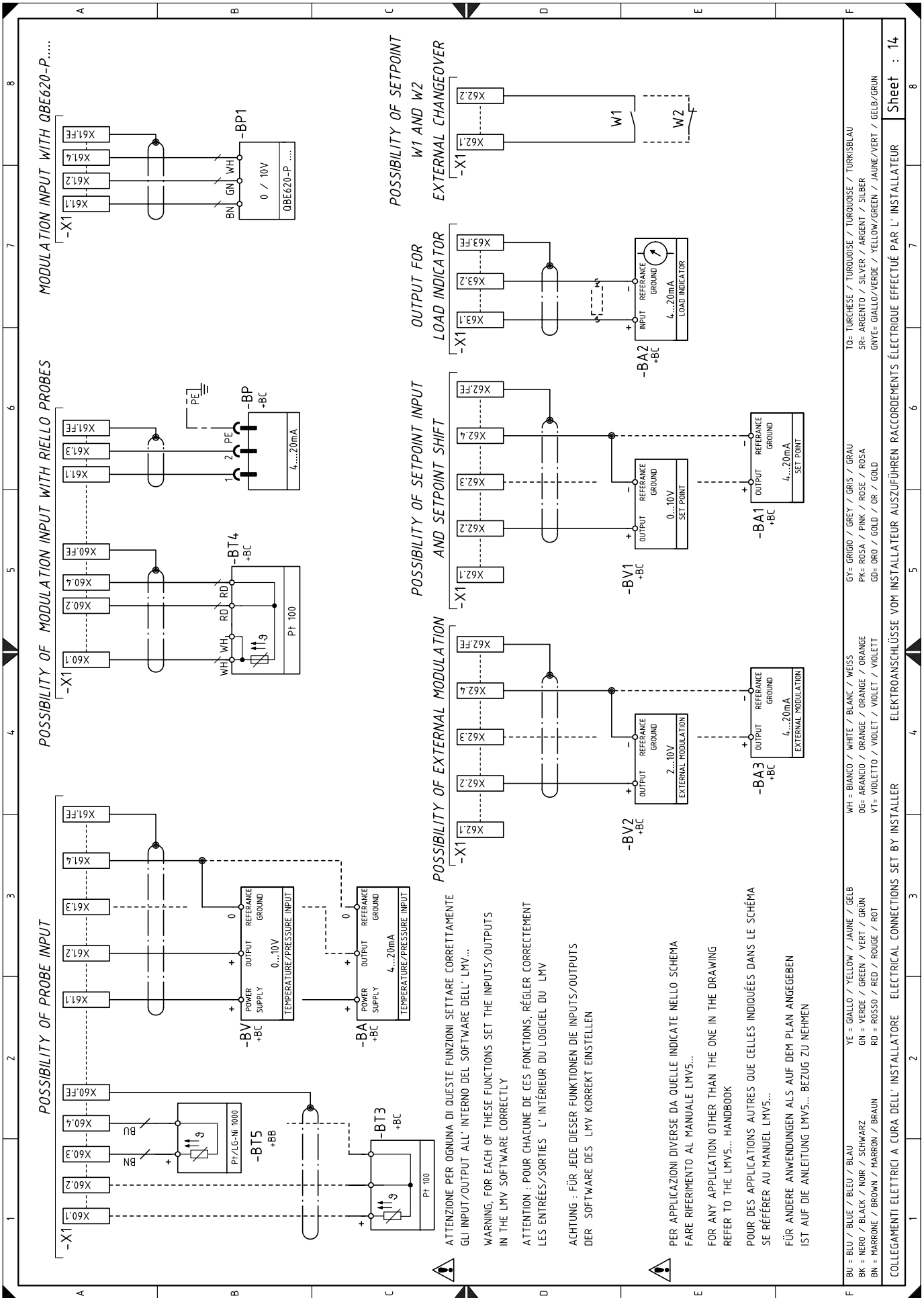

Wiring layout key

A1	Flame control
AZL	Display for flame control
BA	Probe with output under current
BA1	Device with output undercurrent, for modifying remote set-point
BA2	Load indicator with input under current
BA3	Device with output under current for remote modulation
BP	Pressure probe
BP1	Pressure probe
BT5	Probe Pt1000, 2 wires
BT3	Probe Pt100, 3 wires
BT4	Probe Pt100, 3 wires
BV	Output probe in voltage
BV1	Output device in voltage to modify remote set-point
BV2	Device with voltage current output for remote modulation
F1	Fan motor thermal relay
FGR	FGR starting enabling
FU	Auxiliary fuse
G2	RPM sensor
GF	Inverter
H1	Light signalling burner on
H2	Fan motor lockout warning lamp
K1	Clean contacts output relay for fan ON
K2	Clean contacts output relay for burner lockout
K3	Clean contacts output relay for VSD lockout
KM	Relay for VSD control
MV	Fan motor
PA	Air pressure switch
PE	Burner earth
PGMax	Maximum gas pressure switch
PGMin	Minimum gas pressure switch
PGVP	Pilot valves gas pressure switch
QRI	Flame sensor
RS	Remote burner reset button
S1	Emergency stop button
S2	"0 / AUTO" selector
SH3	Burner reset button and lockout signal
SM1	Air servomotor
SM2	Gas servomotor
SM3	FGR servomotor
T1	flame control transformer
TA	Ignition transformer
TL	Limit thermostat/pressure switch
TR	Adjustment thermostat/pressure switch
TS	Safety thermostat/pressure switch
X1	Main terminal supply board
XAZL	AZL display connector
XPGMax	Maximum gas pressure switch
Y	Gas adjustment valve + gas safety valve

RIELLO

RIELLO S.p.A.
I-37045 Legnago (VR)
Tel.: +39.0442.630111
[http:// www.riello.it](http://www.riello.it)
[http:// www.riello.com](http://www.riello.com)