

GB **Forced draught gas burners**

Modulating operation

CE

**UK
CA**

EAC

CODE	MODEL
20166096	RS 1000/EV FGR
20166097	RS 1200/EV FGR



Translation of the original instructions

1	Information and general warnings.....	3
1.1	Information about the instruction manual	3
1.1.1	Introduction.....	3
1.1.2	General dangers.....	3
1.1.3	Other symbols	3
1.1.4	Delivery of the system and the instruction manual	4
1.2	Guarantee and responsibility.....	4
2	Safety and prevention.....	5
2.1	Introduction.....	5
2.2	Personnel training	5
3	Technical description of the burner	6
3.1	Burner designation	6
3.2	Models available.....	6
3.3	Technical data	7
3.4	Electrical data.....	7
3.5	Burner categories - Countries of destination	7
3.6	Maximum dimensions.....	8
3.7	Firing rates	9
3.8	Test boiler.....	9
3.9	Burner description	10
3.10	Electrical panel description.....	11
3.11	Burner equipment.....	11
3.12	Flame control (LMV52.200...).....	12
3.13	Servomotor.....	14
4	Installation	15
4.1	Notes on safety for the installation	15
4.2	Handling	15
4.3	Preliminary checks	15
4.4	Operating position	16
4.5	Removal of the locking screws from the shutter.....	16
4.6	Preparing the boiler	16
4.6.1	Boring the boiler plate	16
4.6.2	Blast tube length.....	16
4.7	Securing the burner to the boiler	17
4.8	Access to head internal part.....	17
4.9	Combustion head adjustment.....	18
4.10	Ignition pilot burner	18
4.10.1	Ignition pilot positioning	18
4.11	FGR duct system.....	19
4.12	Gas feeding	20
4.12.1	Gas feeding line (Example) - Please refer to the gas train documentation for more information	20
4.12.2	Gas train	21
4.12.3	Gas train installation	21
4.12.4	Gas pressure	21
4.13	Electrical wiring	23
4.13.1	Supply cables and external connections passage	23
4.13.2	Shielding the connections	24
4.13.3	Motor rotation	24
5	Start-up, calibration and operation of the burner	25
5.1	Notes on safety for the first start-up	25
5.2	Adjustments prior to ignition	25
5.3	Burner start-up	26

5.4	Burner ignition	26
5.5	Combustion air adjustment	26
5.5.1	Air / gas adjustment and output modulation.....	26
5.6	FGR commissioning.....	27
5.7	Pressure switch adjustment	28
5.7.1	Air pressure switch - CO check.....	28
5.7.2	Maximum gas pressure switch.....	28
5.7.3	Minimum gas pressure switch.....	28
5.7.4	PVP pressure switch kit	29
5.8	Final checks (with burner operating).....	29
6	Maintenance	30
6.1	Notes on safety for the maintenance	30
6.2	Maintenance programme	30
6.2.1	Maintenance frequency.....	30
6.2.2	Safety test - with gas ball valve closed	30
6.2.3	Checking and cleaning.....	30
6.2.4	Safety components	31
6.3	Adjustment fan motor covering with external rpm.....	32
6.4	Opening the burner	33
6.5	Closing the burner.....	33
7	Faults - Probable causes - Solutions	34
A	Appendix - Accessories	35
B	Appendix - Electrical panel layout.....	36

1 Information and general warnings

1.1 Information about the instruction manual

1.1.1 Introduction

The instruction manual supplied with the burner:

- is an integral and essential part of the product and must not be separated from it; it must therefore be kept carefully for any necessary consultation and must accompany the burner even if it is transferred to another owner or user, or to another system. If the manual is lost or damaged, another copy must be requested from the Technical Assistance Service of the area;
- is designed for use by qualified personnel;
- offers important indications and instructions relating to the installation safety, start-up, use and maintenance of the burner.

Symbols used in the manual

In some parts of the manual you will see triangular DANGER signs. Pay great attention to these, as they indicate a situation of potential danger.

1.1.2 General dangers

The **dangers** can be of **3 levels**, as indicated below.



Maximum danger level!
This symbol indicates operations which, if not carried out correctly, cause serious injury, death or long-term health risks.



This symbol indicates operations which, if not carried out correctly, may cause serious injury, death or long-term health risks.



This symbol indicates operations which, if not carried out correctly, may cause damage to the machine and/or injury to people.

1.1.3 Other symbols



DANGER: LIVE COMPONENTS
This symbol indicates operations which, if not carried out correctly, lead to electric shocks with lethal consequences.



DANGER: FLAMMABLE MATERIAL
This symbol indicates the presence of flammable materials.



DANGER: BURNING
This symbol indicates the risks of burns due to high temperatures.



DANGER: CRUSHING OF LIMBS
This symbol indicates the presence of moving parts: danger of crushing of limbs.



WARNING: MOVING PARTS

This symbol indicates that you must keep limbs away from moving mechanical parts; danger of crushing.



DANGER: EXPLOSION

This symbol signals places where an explosive atmosphere is present. An explosive atmosphere is defined as a mixture of dangerous substances with air, under atmospheric conditions, in the form of gases, vapours, mist or dust in which, after ignition has occurred, combustion spreads to the entire unburned mixture.



PERSONAL PROTECTION EQUIPMENT

These symbols indicate the equipment that must be worn and kept by the operator for protection against threats against safety and/or health while at work.



MOUNT CASING

This symbol indicates that it is mandatory to mount casing again after maintenance, cleaning or checks.



ENVIRONMENTAL PROTECTION

This symbol gives indications for the use of the machine with respect for the environment.



IMPORTANT INFORMATION

This symbol indicates important information that you must bear in mind.

- This symbol indicates a list.

Abbreviations used

Ch.	Chapter
Fig.	Figure
Page	Page
Sec.	Section
Tab.	Table

1.1.4 Delivery of the system and the instruction manual

When the system is delivered, it is important that:

- the instruction manual is delivered to the user by the system manufacturer, with the recommendation to keep it in the room where the heat generator is to be installed.
- The instruction manual shows:
 - the serial number of the burner;

.....

- the address and telephone number of the nearest Assistance Centre.

.....

- The system supplier must carefully inform the user about:
 - the use of the system;
 - any further tests that may be required before activating the system;
 - maintenance, and the need to have the system checked at least once a year by a representative of the manufacturer or another specialised technician. To ensure a periodic check, the manufacturer recommends the drawing up of a Maintenance Contract.

1.2 Guarantee and responsibility

The manufacturer guarantees its new products from the installation date, in accordance with the regulations in force and/or the sales contract. At the moment of the first start-up, check that the burner is integral and complete.



WARNING

Failure to observe the information given in this manual, operating negligence, incorrect installation and carrying out of non authorised modifications will result in the annulment by the manufacturer of the guarantee that it supplies with the burner.

In particular, the rights to the guarantee and the responsibility will no longer be valid, in the event of damage to things or injury to people, if such damage/injury was due to any of the following causes:

- incorrect installation, start-up, use and maintenance of the burner;
- improper, incorrect or unreasonable use of the burner;
- intervention of unqualified personnel;
- carrying out of unauthorised modifications on the equipment;
- use of the burner with safety devices that are faulty, incorrectly applied and/or not working;
- installation of untested supplementary components on the burner;
- powering of the burner with unsuitable fuels;
- faults in the fuel supply system;
- use of the burner even following an error and/or an irregularity;
- repairs and/or overhauls incorrectly carried out;
- modification of the combustion chamber with inserts that prevent the regular development of the structurally established flame;
- insufficient and inappropriate surveillance and care of those burner components most likely to be subject to wear and tear;
- the use of non-original components, including spare parts, kits, accessories and optional;
- force majeure.

The manufacturer furthermore declines any and every responsibility for the failure to observe the contents of this manual.

2 Safety and prevention

2.1 Introduction

The burners have been designed and built in compliance with current regulations and directives, applying the known technical rules of safety and envisaging all the potential danger situations. It is necessary, however, to bear in mind that the imprudent and clumsy use of the equipment may lead to situations of death risk for the user or third parties, as well as the damaging of the burner or other items. Inattention, thoughtlessness and excessive confidence often cause accidents; the same applies to tiredness and sleepiness.

It is a good idea to remember the following:

- The burner must only be used as expressly described. Any other use should be considered improper and therefore dangerous.

In particular:

it can be applied to boilers operating with water, steam, diathermic oil, and to other users expressly named by the manufacturer; the type and pressure of the fuel, the voltage and frequency of the electrical power supply, the minimum and maximum deliveries for which the burner has been regulated, the pressurisation of the combustion chamber, the dimensions of the combustion chamber and the room temperature must all be within the values indicated in the instruction manual.

- Modification of the burner to alter its performance and destinations is not allowed.
- The burner must be used in exemplary technical safety conditions. Any disturbances that could compromise safety must be quickly eliminated.
- Opening or tampering with the burner components is not allowed, apart from the parts requiring maintenance.
- Only those parts envisaged by the manufacturer can be replaced.



The manufacturer guarantees safety and proper functioning only if all burner components are intact and positioned correctly.

2.2 Personnel training

The user is the person, body or company that has acquired the machine and intends to use it for the specific purpose. He is responsible for the machine and for the training of the people working around it.

The user:

- undertakes to entrust the machine exclusively to suitably trained and qualified personnel;
- undertakes to inform his personnel in a suitable way about the application and observance of the safety instructions. With that aim, he undertakes to ensure that everyone knows the use and safety instructions for his own duties;
- Personnel must observe all the danger and caution indications shown on the machine.
- Personnel must not carry out, on their own initiative, operations or interventions that are not within their province.
- Personnel must inform their superiors of every problem or dangerous situation that may arise.
- The assembly of parts of other makes, or any modifications, can alter the characteristics of the machine and hence compromise operating safety. The manufacturer therefore declines any and every responsibility for any damage that may be caused by the use of non-original parts.

In addition:



- the user must take all the measures necessary to prevent unauthorised people gaining access to the machine
- the user must inform the manufacturer if faults or malfunctioning of the accident prevention systems are noticed, along with any presumed danger situation
- personnel must always use the personal protective equipment envisaged by legislation and follow the indications given in this manual

3 Technical description of the burner

3.1 Burner designation

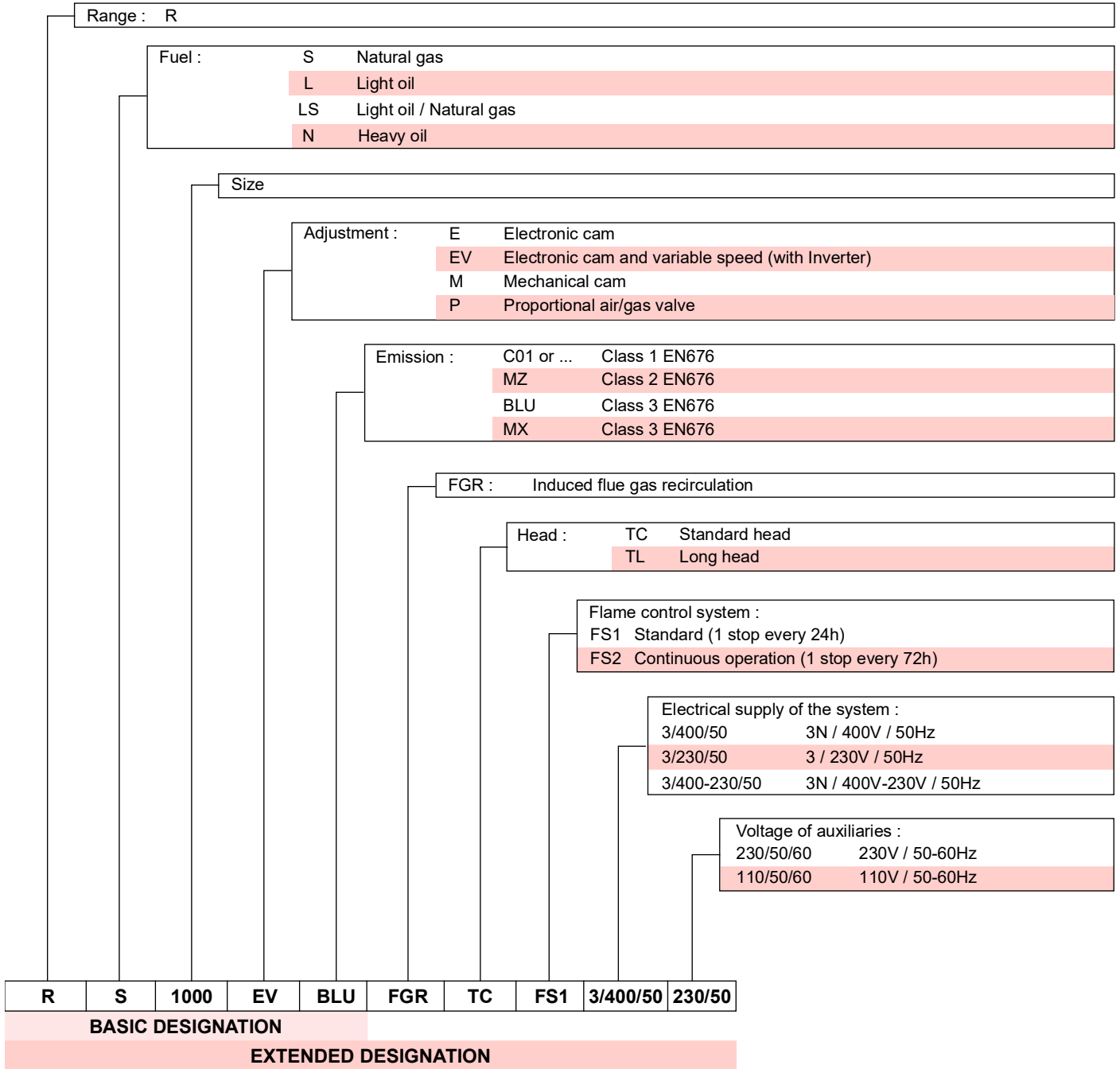

3.2 Models available

Designation	Voltage	Start-up	Code
RS 1000/EV FGR	3/400/50	Inverter	20166096
RS 1200/EV FGR	3/400/50	Inverter	20166097

Tab. A

3.3 Technical data

Model		RS 1000/EV FGR		RS 1200/EV FGR	
Output ⁽¹⁾	min - max	kW	1100/4000 - 10100		1500/5500 - 11100
Output ⁽¹⁾					
Fuels		Natural gas: G20 (methane gas) - G25			
Operation		– FS1 Intermittent (min. 1 stop in 24 hours) ⁽³⁾ – Modulating			
Standard applications		Boilers: water, steam, diathermic oil			
Ambient temperature		°C	0 - 50		
Combustion air temperature		°C max	60		
Noise levels ⁽²⁾	Sound pressure	dB(A)	85		89.3
	Sound power		99		99.7
Weight		kg	480		520
CE		CE - 0476DP3335			

Tab. B

- (1) Reference conditions: Ambient temperature 20°C - Gas temperature 15°C - Barometric pressure 1013 mbar - Altitude 0 m a.s.l.
 (2) Sound pressure measured in manufacturer's combustion laboratory, with burner operating on test boiler and at maximum rated output. The sound power is measured with the "Free Field" method, as per EN 15036, and according to an "Accuracy: Category 3" measuring accuracy, as set out in EN ISO 3746.
 (3) The burner is factory set for FS1 operation (1 stop every 24 hours); it can be converted to FS2 operation (continuous - 1 stop every 72 hours), by changing the parameters using the menu of the AZL Display.

3.4 Electrical data

Model		RS 1000/EV FGR		RS 1200/EV FGR	
Main electrical supply		3~ 400V +/-10% 50 Hz			
Control circuit power supply		1N ~ 230V 50 Hz			
Max. electrical power absorbed	kW max	24.9		28	
Protection level		IP 54			

Tab. C

3.5 Burner categories - Countries of destination

Destination country	Gas category
AT - BG - CH - CZ - DK - EE - ES - FI - GB - GR - HU - IE - IS - IT - LT - LV - NO - PT - RO - SE - SI - SK - TR	I ₂ H
DE	I ₂ ELL
NL	I ₂ EK
FR	I ₂ E _r
BE	I ₂ E(R)
LU - PL	I ₂ E

Tab. D

3.6 Maximum dimensions

The maximum dimensions of the burner are shown in Fig. 1. Bear in mind that inspection of the combustion head requires the burner to be opened and the rear part turned on the hinge.

The maximum dimensions of the open burner are indicated by the L and R positions.

The I position is reference for the refractory thickness of the boiler door.

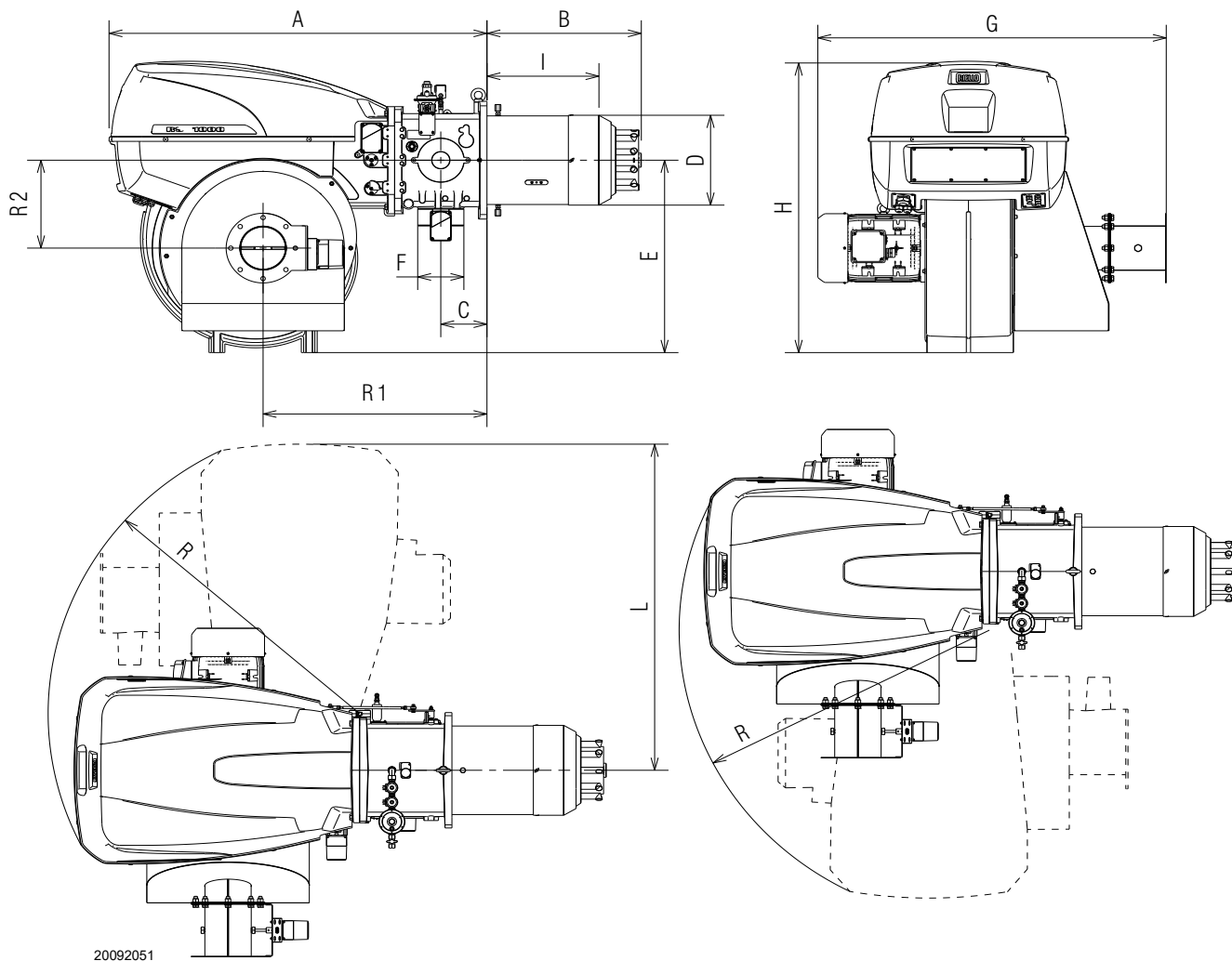

Fig. 1

Model	A	B	C	D	E	F	G	H	I	L	R
RS 1000/EV FGR	1637	669	200	413	885	DN80	1510	1338	485	1493	1350
RS 1200/EV FGR	1637	670	200	456	885	DN80	1630	1338	463	1493	1350

Tab. E

3.7 Firing rates

The **MAXIMUM OUTPUT** is chosen from within the continuous diagram area (Fig. 2).

The **MINIMUM OUTPUT** must not be lower than the minimum limit of the diagram:

- RS 1000/EV FGR = 4000 kW
- RS 1200/EV FGR = 5500 kW



The firing rate value (Fig. 2) has been obtained considering an ambient temperature of 20C, an atmospheric pressure of 1013 mbar (approx. 0 m a.s.l.), and with the combustion head adjusted as shown on page 18.

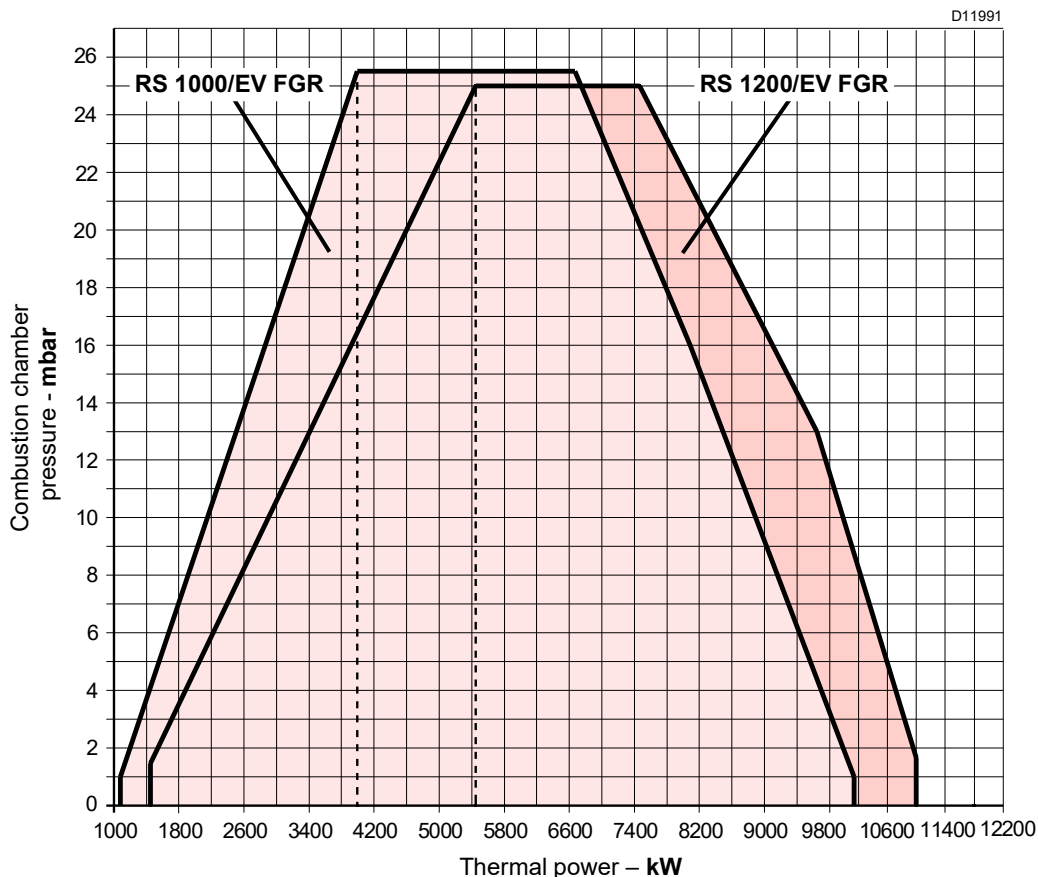

Fig. 2

3.8 Test boiler

The burner/boiler combination does not pose any problems if the boiler is EC approved and its combustion chamber dimensions are similar to those indicated in the diagram (Fig. 3).

If the burner must be combined with a boiler that has not been EC approved and/or its combustion chamber dimensions are clearly smaller than those indicated in the diagram, consult the manufacturer.

The firing rates were obtained in special test boilers, according to EN 676 regulations.

In Fig. 3 you can see the diameter and length of the test combustion chamber.

Example:
Output 7000 kW - diameter 120cm - length 6m.

MODULATING RATIO

The modulating ratio, obtained in test boilers in accordance with standard EN 676, is 7:1.

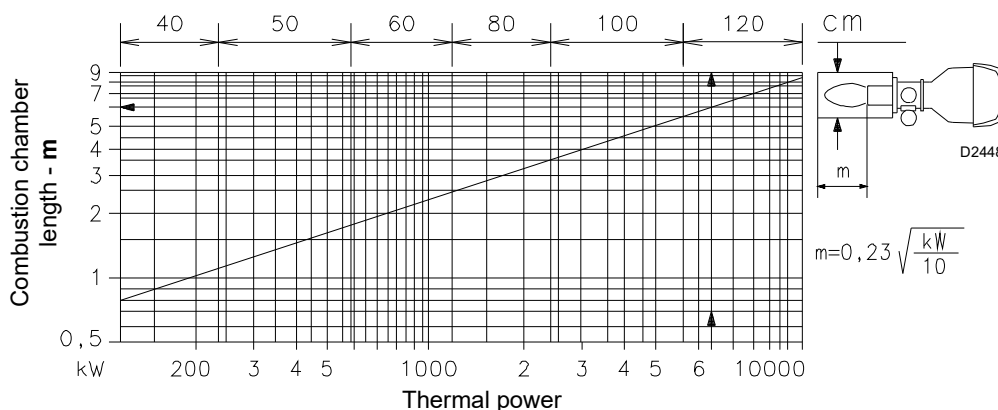

Fig. 3

3.9 Burner description

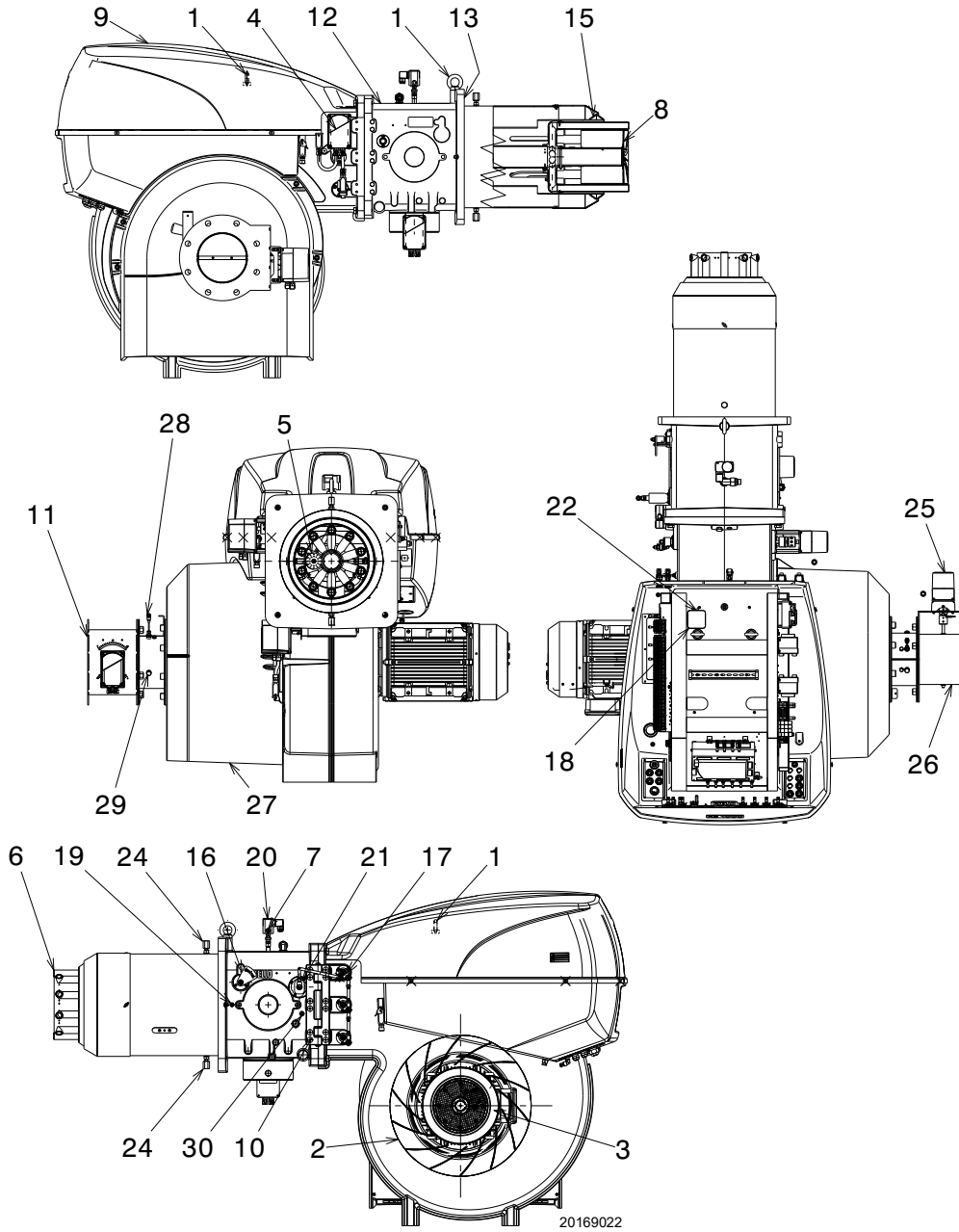

Fig. 4

- | | |
|-----------------------------------------------------------------------------------------------------------------------------------------------------------------------------------------------------------------------------------------------------------------------------------------------------------------------------------------------------------------------------------------------------------------------------------------------------------------------------------------------------------------------------------------------------------------------------------------------------------------------------------------------------------------------------------------------------------------------------------------------------------|-----------------------------------------------------------------------------------------------------------------------------------------------------------------------------------------------------------------------------------------------------------------------------------------------------------------------------------------------------------------------------------------------------------------------------------------------------------------------------------------------------------------------------------------------------------------------------------------|
| <ul style="list-style-type: none"> 1 Lifting rings 2 Fan 3 Fan motor with RPM sensor 4 Air damper servomotor 5 Pilot 6 Combustion head 7 Combustion head gas pressure test point 8 Flame stability disc 9 Electrical panel casing 10 Hinge for opening the burner 11 Flue gas recirculation inlet 12 Manifold 13 Gasket for boiler fixing 14 Gas regulator 15 Shutter 16 Combustion head adjustment 17 Air damper movement lever 18 Air pressure switch (differential operating type) 19 Combustion head air pressure test point 20 Maximum gas pressure switch | <ul style="list-style-type: none"> 21 Flame sensor 22 Pressure test point for air pressure switch “+” 23 Gas butterfly valve servomotor 24 Locking screws of the shutter during the transport (replace them with the screws M12x25 supplied with the burner) 25 Flue gas recirculation servomotor 26 Flue gas recirculation regulator 27 Air intake 28 Flue gas recirculation temperature probe 29 Flue gas recirculation pressure switch connection 30 Flame sensor cooling air intake |
|-----------------------------------------------------------------------------------------------------------------------------------------------------------------------------------------------------------------------------------------------------------------------------------------------------------------------------------------------------------------------------------------------------------------------------------------------------------------------------------------------------------------------------------------------------------------------------------------------------------------------------------------------------------------------------------------------------------------------------------------------------------|-----------------------------------------------------------------------------------------------------------------------------------------------------------------------------------------------------------------------------------------------------------------------------------------------------------------------------------------------------------------------------------------------------------------------------------------------------------------------------------------------------------------------------------------------------------------------------------------|



The burner can be opened to the right or to the left without links to the fuel supply side.
When the burner is closed, the hinge can be refitted on the opposite side.

3.10 Electrical panel description

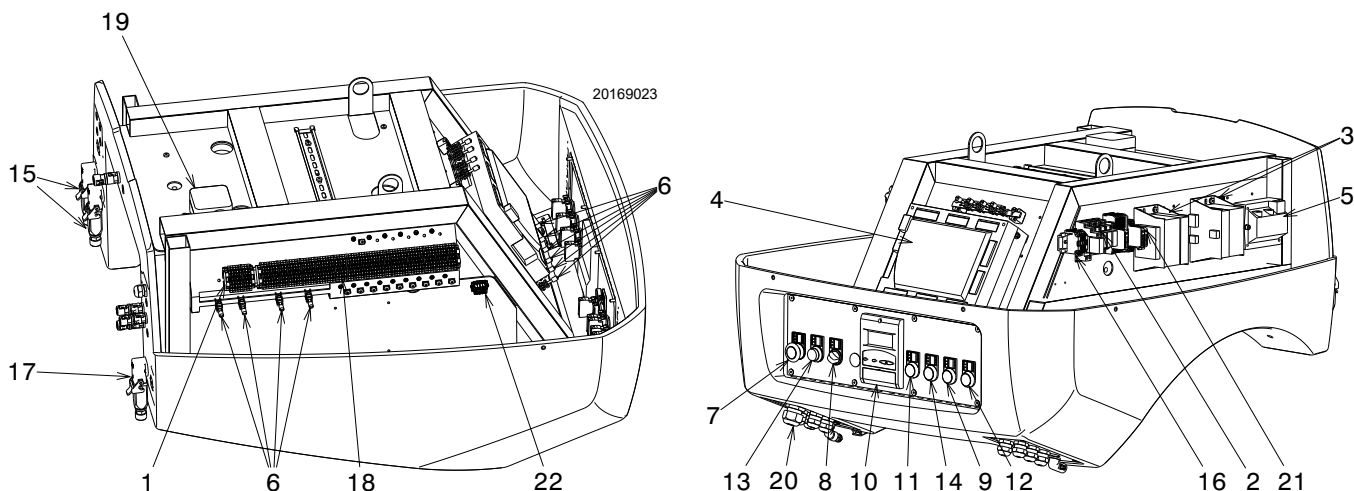

Fig. 5

- 1 Terminal board for kits
- 2 Clean contacts relay
- 3 Electronic cam transformer
- 4 Flame control
- 5 Ignition transformer
- 6 Shielding terminals
- 7 Emergency push-button
- 8 Off-automatic selector
- 9 Light signalling of main fuel valve open
- 10 AZL display
- 11 Light signalling of mains live state
- 12 Fan motor lockout warning lamp
- 13 Light signalling of burner lockout and reset switch
- 14 Call for heat signal

- 15 Plug/socket servomotor
- 16 FGR temperature probe terminal board
- 17 Flame sensor plug/sensor socket
- 18 Main terminal supply board
- 19 Air pressure switch
- 20 Supply cables, external connections and kits
- 21 Auxiliary circuits fuse
- 22 Terminal board for RPM sensor

NOTE

Burner lockout:

- **flame control lockout:** if the pushbutton 13)(Fig. 5) (**red led**), it indicates that the burner is in lockout. release by pressing the pushbutton 13)(Fig. 5).

3.11 Burner equipment

Gasket for gas train flange	No. 1
Thermal insulation screen	No. 1
Screws M12x16	No. 2
Gas flange fixing screws M16x70.	No. 8
Screws M20x70 to secure the burner flange to the boiler .	No. 4
Pressure switch (for leak detection control)	No. 1
Cable grommets kit for optional electrical wiring input . . .	No. 1
Spare parts list	No. 1
Technical instructions	No. 1



It is recommended to tighten the screws of the gas flange with a tightening torque of:

- (DN80) **40 Nm** ±10%;
- (DN100) **50 Nm** ±10%;
- (DN125) **60 Nm** ±10%.

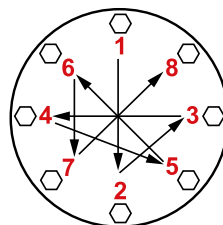

Tighten the nuts gradually (first to 30%, then to 60% up to 100%) according to the cross pattern shown in the figure.

3.12 Flame control (LMV52.200...)

Warnings



To avoid accidents, material or environmental damage, observe the following instructions!

The LMV52.200 is a safety device! Avoid opening or modifying it, or forcing its operation. Riello S.p.A. cannot assume any responsibility for damage resulting from unauthorised interventions!

Risk of explosion!

An incorrect configuration can provoke fuel overcharging, with the consequential risk of explosion! Operators must be aware that incorrect settings made on the AZL5... display and operating unit and incorrect settings of the fuel and / or air actuator positions can lead to dangerous burner operating conditions.

- All interventions (assembly and installation operations, assistance, etc.) must be carried out by qualified personnel.
- Before modifying the wiring in the LMV52 flame control connection area, fully disconnect the system from the power supply (omnipolar separation). Check the system is not powered and cannot be accidentally reconnected. Failure to do this will lead to the risk of electrocution.
- Protection against electrocution from the LMV52... flame control and all connected electric components is obtained with correct assembly.
- Before any intervention (assembly and installation operations, assistance, etc.), ensure the wiring is in order and that the parameters are correctly set, then make the safety checks.
- Falls and collisions can negatively affect the safety functions.

In this case, the flame control must not be operated, even if it displays no evident damage.

- In programming mode, the position check of actuators and VSD (checking electronic fuel / air ratio control) is different from the check during automatic operation. As for automatic operation, the actuators are guided together to the positions requested and, if an actuator does not reach the position requested, adjustments are made until the position is actually reached. However, in contrast to automatic operation, there are no time limits to these corrective actions. The other actuators maintain their positions until all actuators have reached the positions currently required.

This is absolutely important to set the fuel / air ratio control system.

During the time the fuel / air ratio curves are being programmed, the person making the plant settings must continuously monitor the quality of the combustion process (e.g. by means of a flue gas analyser). Also, if combustion levels are poor, or in the event of dangerous situations, the commissioning engineer must take appropriate action (e.g. switching off manually).

To ensure the safety and reliability of the LMV52... system, the following instructions must also be followed:

- avoid conditions that can favour the development of condensate and humidity. Otherwise, before switching on again, make sure that the entire flame control is perfectly dry!
- Static charges must be avoided since they can damage the flame control's electronic components when touched.



D9301

Fig. 6

Mechanical structure

The LMV52... flame control is a system to check the burners, based on a microprocessor and equipped with components to adjust and monitor medium and large capacity forced draught burners.

The base flame control of the LMV52... system incorporates the following components:

- Burner control with gas valve proving system
- Electronic fuel / air ratio control with a maximum of 4 actuators
- Optional PID temperature / pressure controller (load controller)
- Optional VSD module Mechanical design

Installation notes

- Check the electric wiring inside the boiler complies with the national and local safety regulations.
- Do not confuse the powered conductors with the neutral ones.
- Make certain that strain relief of the connected cables is in compliance with the relevant standards (e.g. as per DIN EN 60730 and DIN EN 60 335).
- Ensure that spliced wires cannot get into contact with neighbouring terminals. Use adequate ferrules.
- Arrange the HV ignition cables separately, as far as possible from the flame control and the other cables.
- The burner manufacturer must protect unused AC 230V terminals with dummy plugs (refer to sections Suppliers of other accessory items).
- When wiring the unit, make sure that AC 230V mains voltage cables are run strictly separate from extra low-voltage cables to avoid risks of electrical shock hazard.

Electrical connection of flame sensor

It is important for signal transmission to be almost totally free of any disturbances or loss:

- always separate the sensor cables from the other cables:

- Line capacitance reduces the magnitude of the flame signal.
- Use a separate cable.
- Respect the allowed cable lengths.

Technical data

LMV52.200 basic unit	Mains voltage	AC 230V -15% / +10%
	Mains frequency	50 / 60 Hz ± 6%
	Power absorption	< 30W (normal)
	Safety class	I, with components in compliance with II and III, according to DIN EN 60730-1
Load on 'input' terminals	F1 unit fuse (internal)	6.3 AT
	Primary perm. mains fuse (external)	Max. 16 AT
	Undervoltage	
	• Safety switch-off from operating position to mains voltage	< AC 186V
	• Restart when mains voltage picks up	> AC 188V
	Oil pump / magnetic clutch (nominal voltage)	
	• Nominal current	2A
• Power factor	cosφ > 0.4	
Load on 'output' terminals	Air pressure switch test valve (nominal voltage)	
	• Nominal current	0.5A
	• Power factor	cosφ > 0.4
	Total load on the contacts:	
• Mains voltage	AC 230V -15 % / +10%	
• Total unit input current (safety circuit) load on contacts due to:	Max. 5 A	
	- Fan motor contactor	
	- Ignition transformer	
	- Valve	
	- Oil pump / magnetic clutch	
	Single contact loading:	
	Fan motor contactor (nominal voltage)	
	• Nominal current	1A
	• Power factor	cosφ > 0.4
	Alarm output (nominal voltage)	
	• Nominal current	1A
	• Power factor	cosφ > 0.4
	Ignition transformer (nominal voltage)	
	• Nominal current	2A
	• Power factor	cosφ > 0.2
	Fuel gas valve (nominal voltage)	
	• Nominal current	2A
	• Power factor	cosφ > 0.4
	Fuel oil valve (nominal voltage)	
	• Nominal current	1A
	• Power factor	cosφ > 0.4
Cable lengths	Main line	Max. 100m (100 pF/m)
Environmental conditions	Operation	DIN EN 60721-3-3
	Climatic conditions	Class 3K3
	Mechanical conditions	Class 3M3
	Temperature range	-20...+60°C
	Humidity	< 95% RH

Tab. F

3.13 Servomotor

Warnings



WARNING

To avoid accidents, material or environmental damage, observe the following instructions!

Avoid opening, modifying or forcing the actuators.

- All interventions (assembly and installation operations, assistance, etc.) must be carried out by qualified personnel.
- Before modifying the wiring in the SQM4... system connection area, fully disconnect the burner control device from the power supply (omnipolar separation).
- To avoid the risk of electrocution, protect the connection terminals in a suitable manner and correctly fix the cover.
- Check the wiring is in order.
- Falls and collisions can negatively affect the safety functions. In this case, the unit must not be operated, even if it displays no evident damage.

Assembly notes

- Check the relevant national safety standards are respected.
- The connection between the actuator command shaft and the control element must be rigid, without any mechanical play.
- To avoid an excessive load on the bearings due to rigid hubs, the use of compensation clutches without any mechanical play is recommended (e.g. metal bellows-type clutches).

Installation notes

- Arrange the H.V. ignition cables separately, as far as possible from the flame control and the other cables.
- To avoid the risk of electrocution, make sure that the 230V AC section of the SQM4... unit is fully separated from the functional low-voltage section.
- The static torque is reduced when the electrical supply of the actuator is switched off.
- The housing cover may only be removed for short periods of time for wiring or when making the addressing. In similar cases, make sure that dust or dirt does not penetrate inside the actuator.
- The actuator comprises a PCB with ESD-sensitive components.
- The top side of the board carries a cover which affords protection against direct contact. This protective cover must not be removed! The underside side of the board must not be touched.



WARNING

During the maintenance or replacement of the actuators, be careful not to invert the connectors.

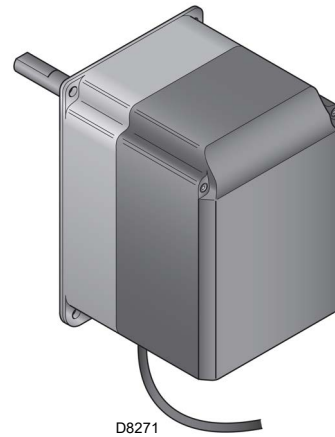

D8271

Fig. 7

Technical data

Operating voltage	AC 2 x 12V via bus cable from the base unit or via a separate transformer
Safety class	extra low-voltage with safe isolation from mains voltage
Power absorption	
– SQM45...	9...15 VA
– SQM48...	26...34 VA
Degree of protection	to EN 60 529, IP 54, provided adequate cable entries are used
Cable connection	RAST3,5 connectors
Rotation direction	- Anticlockwise (standard) - Clockwise (inverted rotation)
Nominal torque (max)	
– SQM45...	3 Nm
– SQM48...	20 Nm
Holding torque (max)	
– SQM45...	1.5 Nm
– SQM48...	20 Nm
Running time (min.) for 90°	
– SQM45...	10 s.
– SQM48...	30 s.
Weight	
– SQM45...	1 kg approx.
– SQM48...	1.6 kg approx.
Environmental conditions:	
Operation	DIN EN 60 721-3-3
Climatic conditions	Class 3K3
Mechanical conditions	Class 3M3
Temperature range	-20...+60°C
Humidity	< 95% RH

Tab. G

4.4 Operating position



- The burner is designed to operate only in positions 1 and 4 (Fig. 9).
- Installation 1 is preferable, as it is the only one that allows the maintenance operations as described in this manual.
- Installation 4 permits operation but makes maintenance and inspection of the combustion head more difficult.



- Any other position could compromise the correct operation of the appliance.
- Installations 2, 3 and 5 are prohibited for safety reasons.

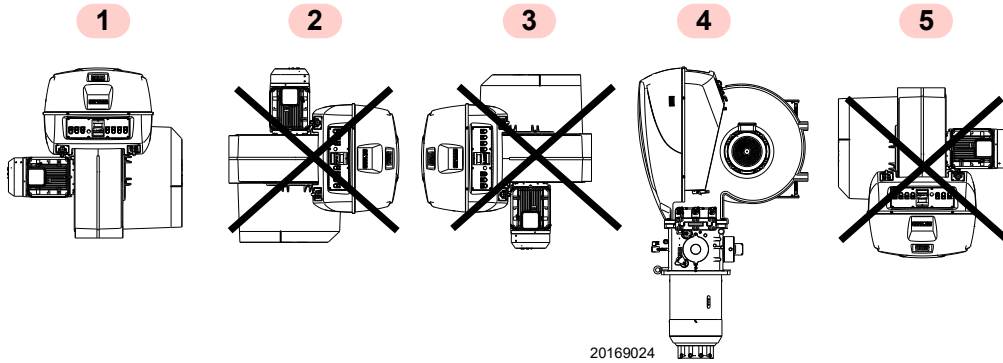

Fig. 9

4.5 Removal of the locking screws from the shutter



Remove the screws and the nuts 1)- 2)(Fig. 10), before installing the burner on the boiler. Replace them with the screws 3) M12x16 supplied with the burner.

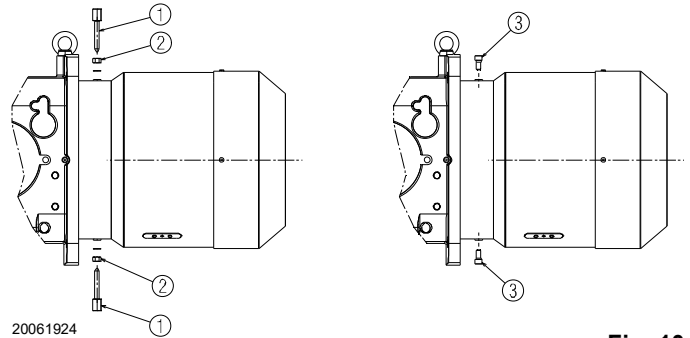

Fig. 10

4.6 Preparing the boiler

4.6.1 Boring the boiler plate

Pierce the closing plate of the combustion chamber, as in Fig. 11. The position of the threaded holes can be marked using the thermal insulation screen supplied with the burner.

4.6.2 Blast tube length

The length of the blast tube must be selected according to the indications provided by the manufacturer of the boiler, and in any case it must be greater than the thickness of the boiler door complete with its refractory.

For boilers with front flue passes 1)(Fig. 12) or flame inversion chamber, a protection in refractory material 5) must be inserted between the boiler fetting 2) and the blast tube 4).

This protection must not compromise the extraction of the blast tube.

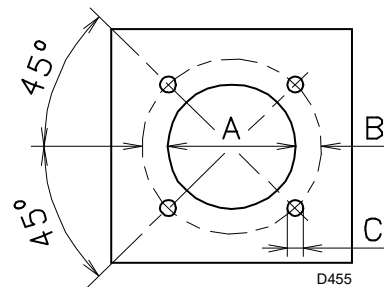

Fig. 11

mm	A	B	C
RS 1000/EV FGR	460	608	M 20
RS 1200/EV FGR	500	608	M 20

Tab. H

4.7 Securing the burner to the boiler



Prepare a suitable lifting system using rings 3)(Fig. 12).



The seal between burner and boiler must be airtight.

- Insert the thermal protection supplied with the blast tube 4).
- Insert the entire burner on the boiler hole, previously fitted, as in Fig. 11, and fix it with the screws supplied.

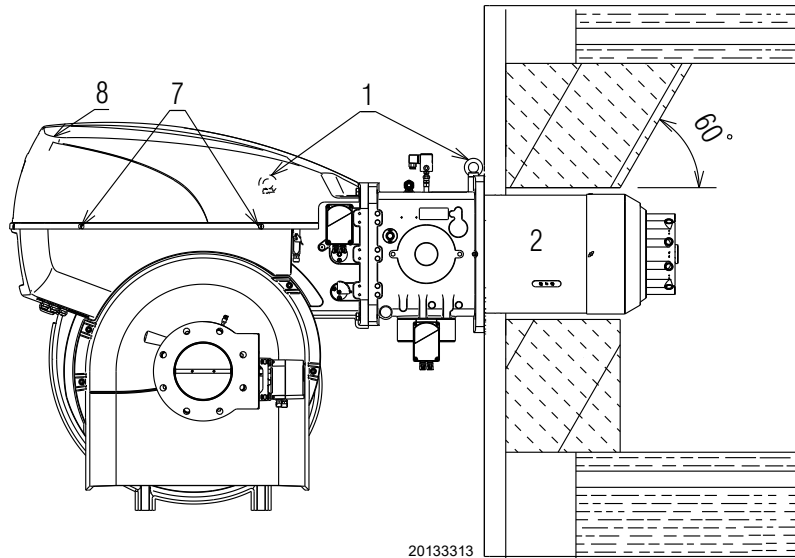

Fig. 12

4.8 Access to head internal part

In order to reach inside the combustion head (Fig. 13) proceed as follows:

- disconnect the flue gas recirculation connection pipe;
- disconnect the gas servomotor socket 1);
- remove the 4 fixing screws 2);
- partially open the burner (about 150 mm) on the hinge;
- disconnect the electrode cables 3);
- fully open the burner on the hinge;

- remove the screw/gas pressure socket 4) of the head;
- unscrew the nut pilot 5);
- pull out the inner part of the head 6).



Be careful as some drops of fuel may leak out during this phase.

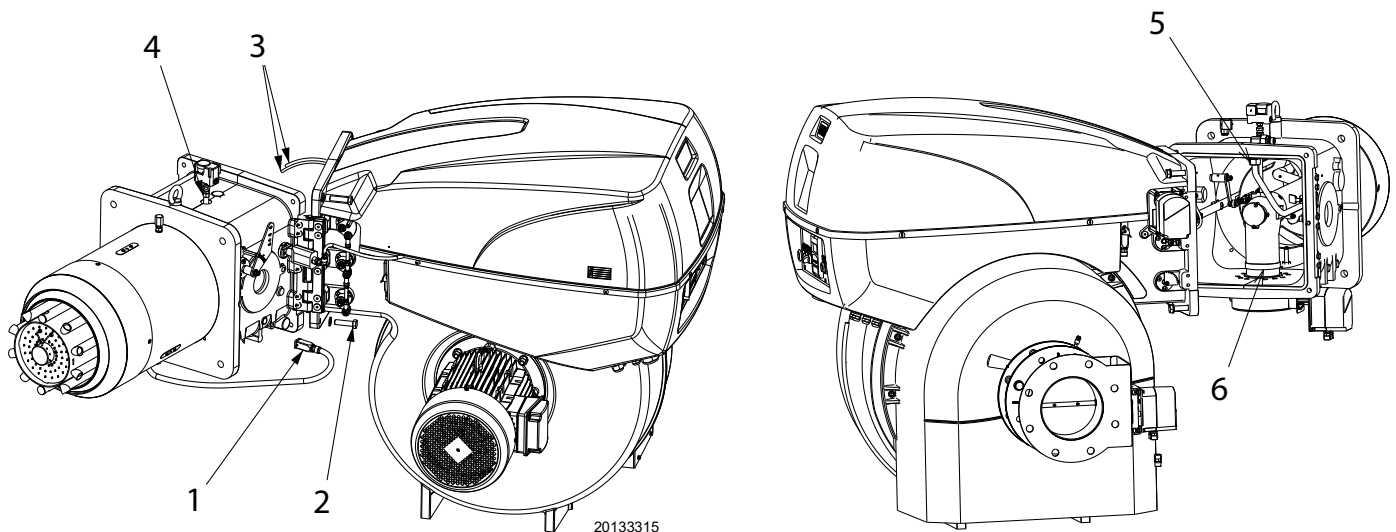

Fig. 13

4.9 Combustion head adjustment

The air damper servomotor 4)(Fig. 4 on page 10) varies the air output according to the output demand, while manually a leverage varies the combustion head adjustment.

The selection of the hole to be used is determined based on the maximum output requested, as illustrated in Tab. I.

In the factory, the adjustment is adjusted for the minimum stroke (hole 0, Fig. 14).

Leverage hole	Output (kW)	
	RS 1000/EV FGR	RS 1200/EV FGR
0	1100	1500
1	2200	2500
2	3200	3700
3	4200	5000
4	5000	6000
5	6000	7000
6	7000	8000
7	8000	9000
8	8900	9800
9	9700	10800
10	10100	11100

Tab. I

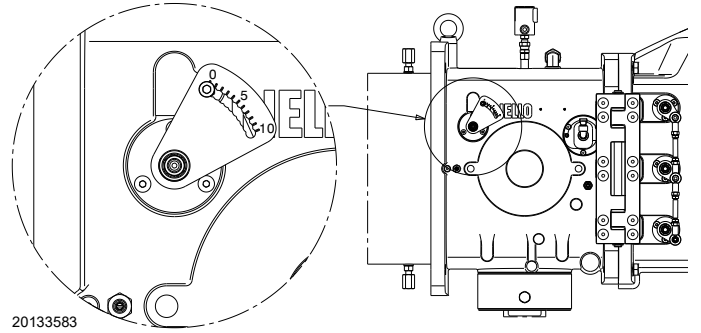

Fig. 14

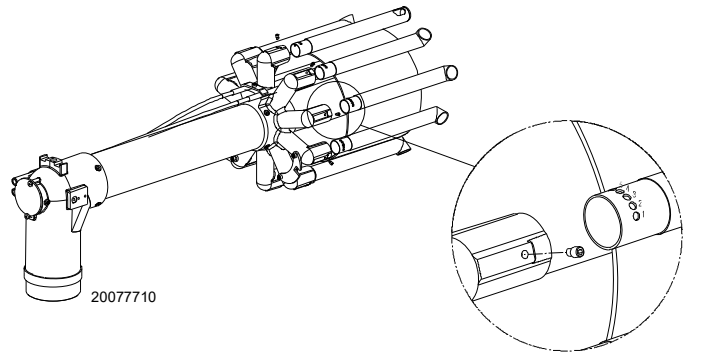

Fig. 15



WARNING

The gas pipes leave the factory calibrated at notch 1.

The adjustment shown in Fig. 15 allows the gas pipes to be positioned in the best way for the application on which the burner is installed (e.g. boilers with flame inversion chamber).

4.10 Ignition pilot burner

For correct functioning, adjust the gas pressure (measured on the socket located on the valve) to between **30 ÷ 50 mbar**.

Gas	mbar	Sm ³ /h
G20	1.5	12.3
G31	1.4	3.2

Tab. J



WARNING

Before starting the main burner, make sure that the pilot flame is stable, checking the value of the flame signal on the AZL display on the boiler's main panel.

Continue with the burner ignition procedure, checking that the pilot has come on correctly.

4.10.1 Ignition pilot positioning

Position the electrode at a distance of 2 - 3 mm from the hole, as shown in Fig. 16.

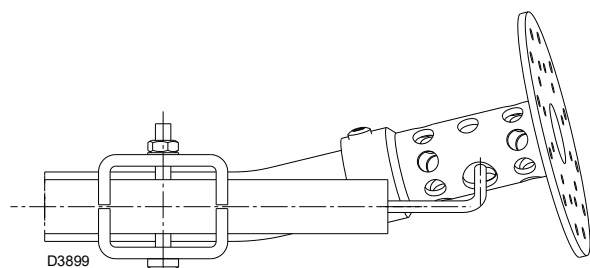

Fig. 16

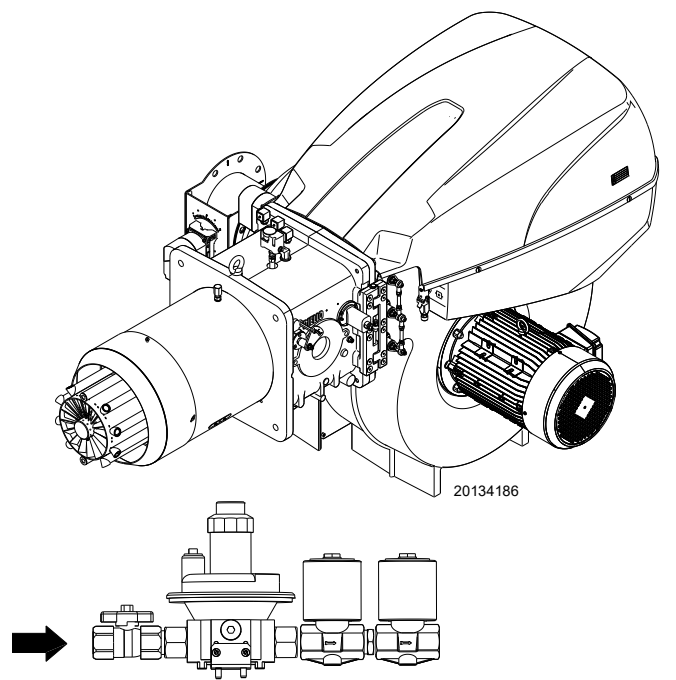

Fig. 17

4.11 FGR duct system

- Normally the duct would connect to the stack as shown in Fig. 18, with a 45° cut facing the flue gas flow and with the center of the cut centered in the stack. The duct could be made to the smoke box, but must still be located with the same 45° cut facing the flue gas flow stream and with the center of the cut in the center of the stream.
- The duct should be routed in a manner that has the minimum number of elbows and provides for the normal expansion and contraction of the piping. Long duct runs can change length by over 1" and can put an extreme load on the connecting points that could cause component failures. The design must include offsets that will allow for the required movement of the piping without undue force on the burner or stack.
- Duct expansion and contraction can be managed by using two relatively long duct runs that are 90° apposed to each other. A small movement in the angle between these two legs will provide the space needed to absorb the expansion and contraction. The ends of the FGR duct must be securely attached to allow this to work properly, and prevent high loads from being applied to the burner or stack.
- A condensation drip leg must be provided upstream of the FGR control valve and the FGR shutoff valve (if used). There must be sufficient condensate drip legs and catch space (volume of drip legs) to prevent the condensation from flowing

through the control valves and into the fan. In cases of heavy condensation, a condensate drip leg may be required on the bottom of the housing, to remove condensate.

- Determine if pipe reducers are needed for the connection to the FGR control valve and the FGR shutoff valve.
- The duct must be properly supported, handling both the weight of the duct and to control the thermal expansion and contraction. The supports may need to be anchored to provide this stability in the FGR duct.



Uncontrolled condensation can cause premature failure of the control valves, fan and motor.

Adequate means must be provided to remove condensation from the system.

Cold startup will generate significant amounts of condensation.

- The FGR duct is normally made from 8" pipe because it is easily obtainable and inexpensive.
- The duct components must be seal welded, flanged or screwed together to provide an air tight duct. Air leakage into the duct will prevent the system from working properly. It is sufficient to only inspect the welds for a proper seal, they do not need to be leak tested.

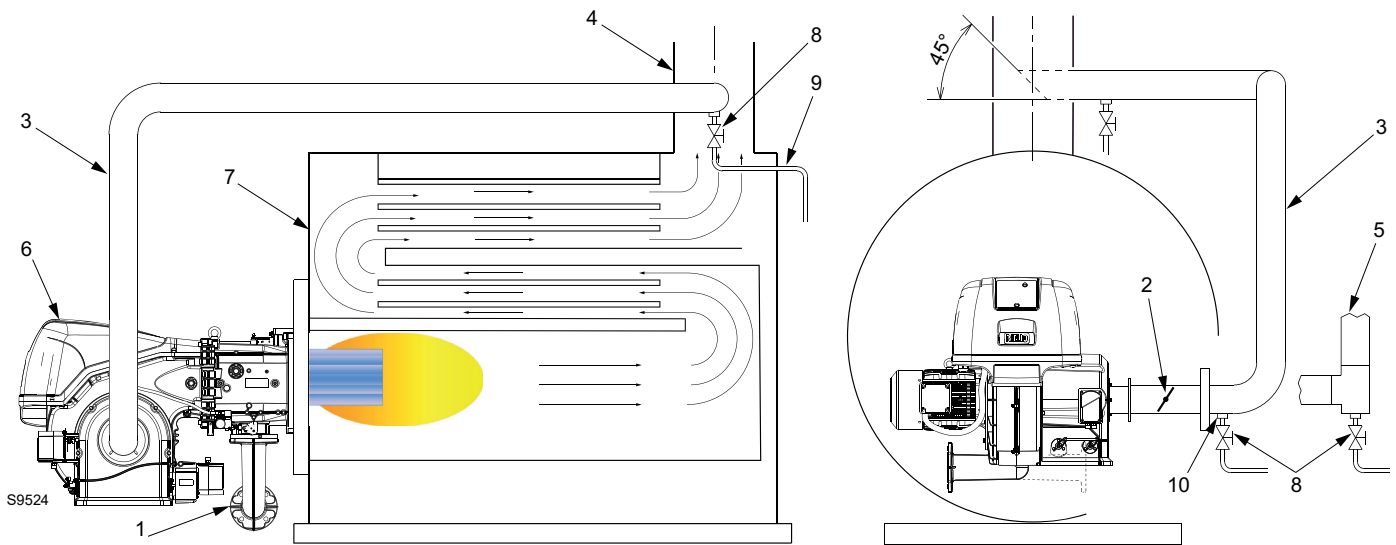

Fig. 18

Key (Fig. 18)

- 1 Primary gas supply inlet
- 2 Inducted FGR modulating damper
- 3 Flue gas recirculation pipe
- 4 Boiler stack
- 5 Alternate Construction Using "T"
- 6 Burner
- 7 Boiler
- 8 Drain Valve (Manual Ball Valve, Stainless Steel)
- 9 Drain line
- 10 Condensate Trap

4.12 Gas feeding



Explosion danger due to fuel leaks in the presence of a flammable source.

Precautions: avoid knocking, attrition, sparks and heat.

Make sure that the fuel interception tap is closed before performing any operation on the burner.



WARNING

The fuel supply line must be installed by qualified personnel, in compliance with current standards and laws.

4.12.1 Gas feeding line (Example) - Please refer to the gas train documentation for more information

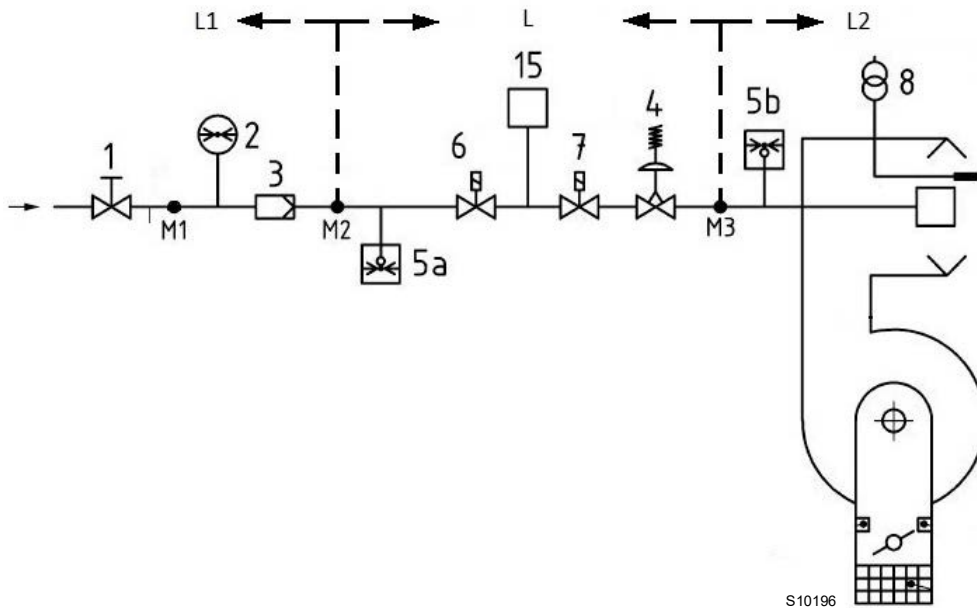

Fig. 19

Key (Fig. 19)

- 1 Manually operated shut-off valve
- 2 Pressure gauge
- 3 Filter
- 4 Governor
- 5a Low pressure protection device
- 5b Maximum gas pressure switch
- 6 1st safety shut-off device
- 7 2nd safety shut-off device
- 8 Ignition device
- 15 Valve leak detection control system
- L Gas train (supplied separately)
- L1 Responsibility of the installer
- L2 Burner
- M1 Pressure test point
- M2 Pressure test point
- M3 Pressure test point

4.12.2 Gas train

Type-approved in accordance with EN 676 and supplied separately from the burner.

4.12.3 Gas train installation



Disconnect the electrical power using the main system switch.



Check that there are no gas leaks.



Beware of train movements: danger of crushing of limbs.



Make sure that the gas train is properly installed by checking for any fuel leaks.



The operator must use appropriate tools for installation.

The gas train is prearranged to be connected to the burner by the flange 1)(Fig. 20).

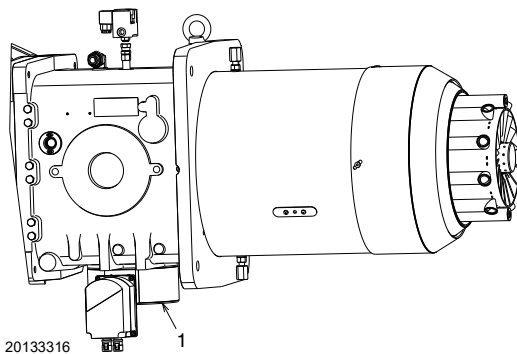

Fig. 20



The data of thermal output and combustion head gas pressure are related to full open (90°) gas butterfly valve.

4.12.4 Gas pressure

Tab. K indicates the pressure drop of the combustion head and the gas butterfly valve depending on the operating output of the burner.

	kW	1 Δp (mbar)		2 Δp (mbar)	
		G 20	G 25	G 20	G 25
RS 1000/EV FGR	4000	9.9	14.4	1.2	1.7
	4500	13.0	18.8	1.5	2.2
	5000	16.0	23.2	1.8	2.7
	5500	19.1	27.6	2.2	3.3
	6000	22.1	32.0	2.6	3.9
	6500	25.2	36.3	3.1	4.6
	7000	28.9	41.6	3.6	5.3
	7500	32.9	47.2	4.1	6.1
	8000	36.9	52.7	4.7	7.0
	8500	41.5	59.4	5.3	7.9
	9000	46.4	66.3	5.9	8.8
RS 1200/EV FGR	9500	51.2	73.3	6.6	9.8
	10000	56.0	80.2	7.3	10.9
	10100	57.0	81.6	7.5	11.1
	5500	18.2	26.6	2.2	3.3
	6000	22.1	32.1	2.6	3.9
	6500	26.0	37.6	3.1	4.6
	7000	29.9	43.2	3.6	5.3
	7500	33.8	48.7	4.1	6.1
	8000	38.6	55.4	4.7	7.0
	8500	43.4	62.1	5.3	7.9
	9000	48.2	68.8	6.0	8.8
9500	53.1	75.5	6.6	9.8	
10000	58.6	83.1	7.4	10.9	
10500	64.4	91.0	8.1	12.0	
11000	70.2	99.0	8.9	13.2	
11100	71.4	100.6	9.1	13.4	

Tab. K

The values shown in Tab. K refer to:

- Natural gas G 20 NCV 9.45 kWh/Sm³ (8.2 Mcal/Sm³)
- Natural gas G 25 NCV 8.13 kWh/Sm³ (7.0 Mcal/Sm³)

Column 1

Pressure drop on combustion head.

Gas pressure measured at the test point 1)(Fig. 21), with:

- combustion chamber at 0 mbar;
- burner working at maximum modulating output;
- combustion head set as on page 18.

Column 2

Pressure loss at gas butterfly valve 2)(Fig. 21) with maximum opening: 90°.

To calculate the approximate output at which the burner operates:

- subtract the combustion chamber pressure from the gas pressure measured at test point 1)(Fig. 21).
- Find, in Tab. K related to the burner concerned, the pressure value closest to the result of the subtraction.
- Read off the corresponding output on the left.

Example RS 1000/EV FGR with G20 natural gas:

Maximum modulating output operation

Gas pressure at test point 1)(Fig. 21)	=	59.2 mbar
Pressure in combustion chamber	=	10 mbar
59.2 - 10	=	49.2 mbar

A pressure of 49.2 mbar, column 1, corresponds in Tab. K to an output of 9000 kW.

This value serves as a rough guide; the effective output must be measured at the gas meter.

To calculate the required gas pressure at test point 1)(Fig. 21), set the maximum modulating output required from the burner operation:

- find the nearest output value in Tab. K for the burner in question.
- read, on the right (column 1), the pressure at the test point 1)(Fig. 21).
- Add this value to the estimated pressure in the combustion chamber.

Example RS 1000/EV FGR with G20 natural gas:

Maximum modulating output operation

Gas pressure at an output of 9000 kW	=	49.2 mbar
Pressure in combustion chamber	=	10 mbar
49.2 + 10	=	59.2 mbar

Pressure required at test point 1)(Fig. 21).

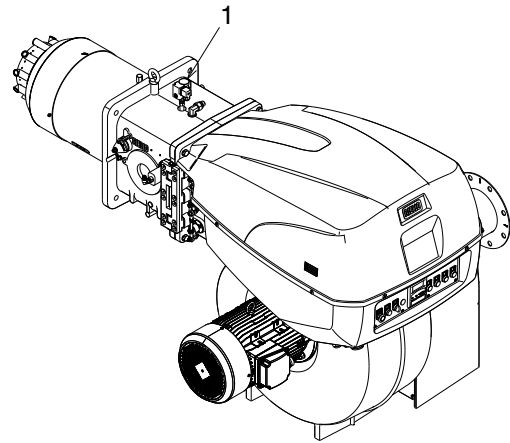
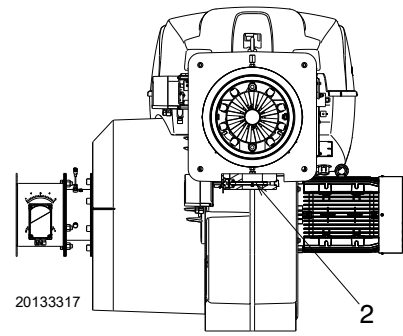

Fig. 21

4.13 Electrical wiring

Notes on safety for the electrical wiring



DANGER

- The electrical wiring must be carried out with the electrical supply disconnected.
- Electrical wiring must be made in accordance with the regulations currently in force in the country of destination and by qualified personnel. Refer to the wiring diagrams.
- The manufacturer declines all responsibility for modifications or connections different from those shown in the wiring diagrams
- Check that the electrical supply of the burner corresponds to that shown on the identification label and in this manual.
- The burner has been type-approved for intermittent use (FS1). This means they should compulsorily be stopped at least once every 24 hours to enable the flame control to perform checks of its own start-up efficiency. Normally, burner stopping is guaranteed by the boiler's thermostat/pressure switch. If this is not the case, a time switch should be fitted in series to TL to stop the burner at least once every 24 hours. Refer to the wiring diagrams.
- The burner is factory set for FS1 operation (1 stop every 24 hours); it can be converted to FS2 operation (continuous - 1 stop every 72 hours), by changing the parameters using the menu of the AZL Display.
- The electrical safety of the device is obtained only when it is correctly connected to an efficient earthing system, made according to current standards. It is necessary to check this fundamental safety requirement. In the event of doubt, have the electrical system checked by qualified personnel. Do not use the gas tubes as an earthing system for electrical devices.
- The electrical system must be suitable for the maximum power absorption of the device, as indicated on the label and in the manual, checking in particular that the section of the cables is suitable for that level of power absorption.
- For the main power supply of the device from the electricity mains:
 - do not use adapters, multiple sockets or extensions;
 - use a multiple pole switch with at least a 3 mm gap between the contacts (overvoltage category III), as envisaged by the present safety standards.
- Do not touch the device with wet or damp body parts and/or in bare feet.
- Do not pull the electric cables.

Before carrying out any maintenance, cleaning or checking operations:



DANGER

disconnect the electrical supply from the burner by means of the main system switch;



DANGER

close the fuel interception tap.



DANGER

Avoid condensate, ice and water leaks from forming.

If the hood is still present, remove it and proceed with the electrical wiring according to the wiring diagrams.

Use flexible cables in compliance with the EN 60 335-1 standard.

4.13.1 Supply cables and external connections passage

All the cables to be connected to the burner should be passed through cable grommets, as shown in Fig. 22.



WARNING

To guarantee the protection level of the burner, it is necessary to close any holes that are still free, using the plugs supplied.

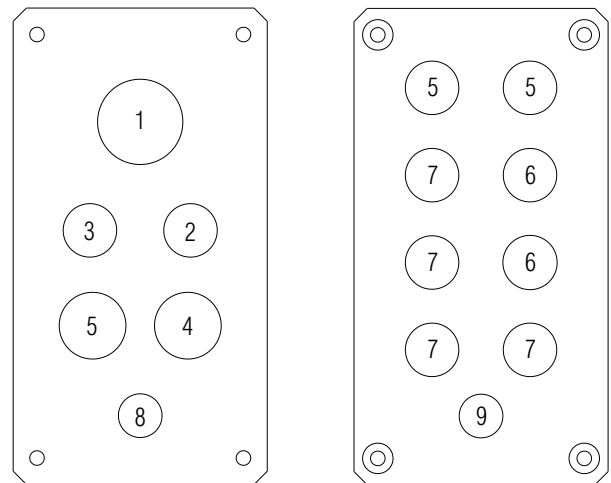

20168334

Fig. 22

Key (Fig. 22)

- 1 Electrical supply
- 2 Minimum gas pressure switch
- 3 Pressure switch for VPS gas valve leak detection
- 4 Gas train
- 5 Consents/Safety
- 6 Available
- 7 Plug
- 8 RPM sensor
- 9 PT 1000 probe for FGR



After carrying out maintenance, cleaning or checking operations, reassemble the hood and all the safety and protection devices of the burner.

4.13.2 Shielding the connections



For the burner to operate correctly, where required, it is necessary to shield the connections.

To shield the motor connection, proceed as follows:

- to access the motor casing, loosen the four screws 1)(Fig. 23) and remove the cover 2);
- remove the shielded coupling 3) screwed to the motor casing.



To make the correct shielding, it is important to bear in mind the necessary length of the connections inside the motor casing.

- Shield the cable 4) running from the VSD (inverter), as shown in Fig. 24 and using the coupling 6);
- install the cable 4) with its relative coupling on the motor casing, fixing it carefully in place with the ring nut 5)(Fig. 23);
- carry out the motor connection as shown in the wiring diagrams;
- fix the grommets/cable terminals of the connections securely and tidily to the terminal board of the motor;
- make a final visual check, then close the motor casing by tightening the 4 screws 1)(Fig. 23).

4.13.3 Motor rotation

As the burner is not fitted with a phase sequence checking device, the motor rotation may be incorrect.



As soon as the burner starts up, go in front of the fan motor cooling fan and check it is rotating anti-clockwise (Fig. 25).

If this is not the case:

- turn the burner switch to position "0" (OFF) and wait for the flame control to carry out the switch-off phase;
- disconnect the power supply to the main panel;
- invert the phases on the three-phase power supply.



This operation must be carried out with the electrical supply disconnected.

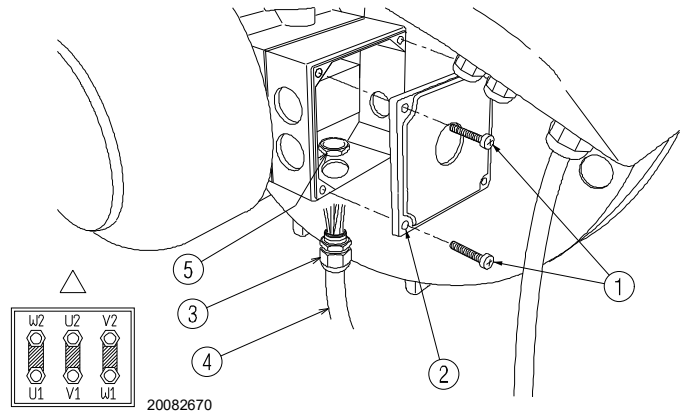

Fig. 23

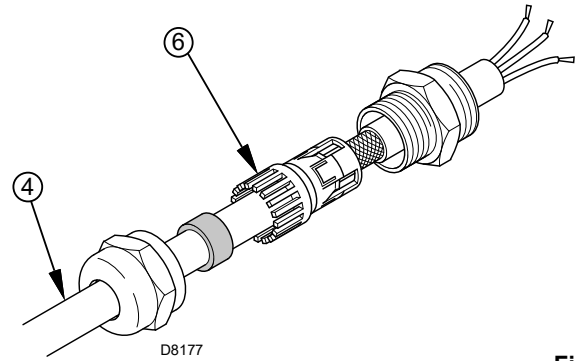

Fig. 24

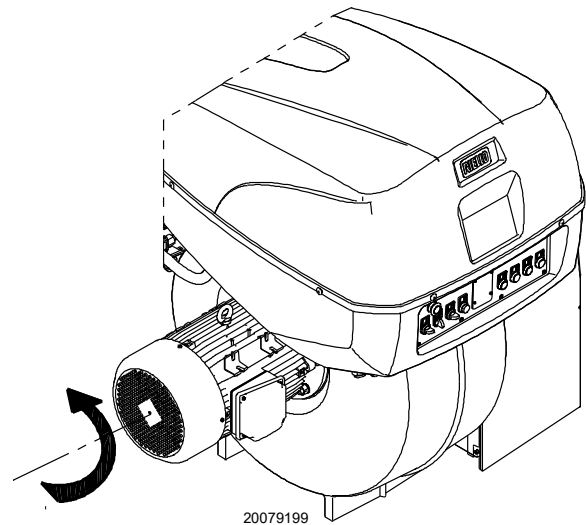

Fig. 25

5 Start-up, calibration and operation of the burner

5.1 Notes on safety for the first start-up



WARNING

The first start-up of the burner must be carried out by qualified personnel, as indicated in this manual and in compliance with the standards and regulations of the laws in force.



WARNING

Refer to paragraph "Safety test - with gas ball valve closed" on page 30 before the first start-up.



WARNING

Check the correct working of the adjustment, command and safety devices.

5.2 Adjustments prior to ignition

The adjustments to be carried out are:

- slowly open the manual valves situated upstream from the gas train;
- adjust the minimum gas pressure switch (Fig. 30 on page 28) to the start of the scale;
- adjust the maximum gas pressure switch (Fig. 29 on page 28) to the end of the scale;
- adjust the air pressure switch (Fig. 28 on page 28) to the start of the scale;
- purge the air from the gas line. We recommend using a plastic tube routed outside the building and to purge air until gas is smelt.
- Fit a U-type pressure gauge or a differential pressure gauge (Fig. 26), with socket (+) on the gas pressure of the pipe coupling and (-) in the combustion chamber. Used to approximately calculate the MAX burner output.
- Connect two lamps or testers to the two gas line solenoids to check the exact moment in which voltage is supplied. This operation is unnecessary if each of the two solenoid valves is equipped with a pilot light that signals voltage passing through.



CAUTION

Before starting up the burner, it is good practice to adjust the gas train so that ignition takes place in conditions of maximum safety, i.e. with gas delivery at the minimum.

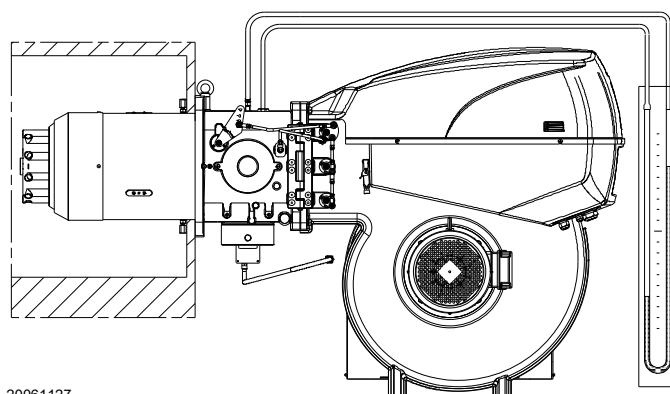

20061127

Fig. 26

5.3 Burner start-up

Close the remote controls and set the switch to 1)(Fig. 27) in “**AUTO**” position.

Check that the lamps or the testers connected to the solenoid valves or the warning lights on the solenoid valves indicate no voltage presence.

If they indicate the presence of voltage, stop the burner immediately and check the electric connections.

When the limit thermostat (TL) is closed, the heat request indication “**CALL FOR HEAT**” 2)(Fig. 27) must be displayed and the burner starts the starting cycle.

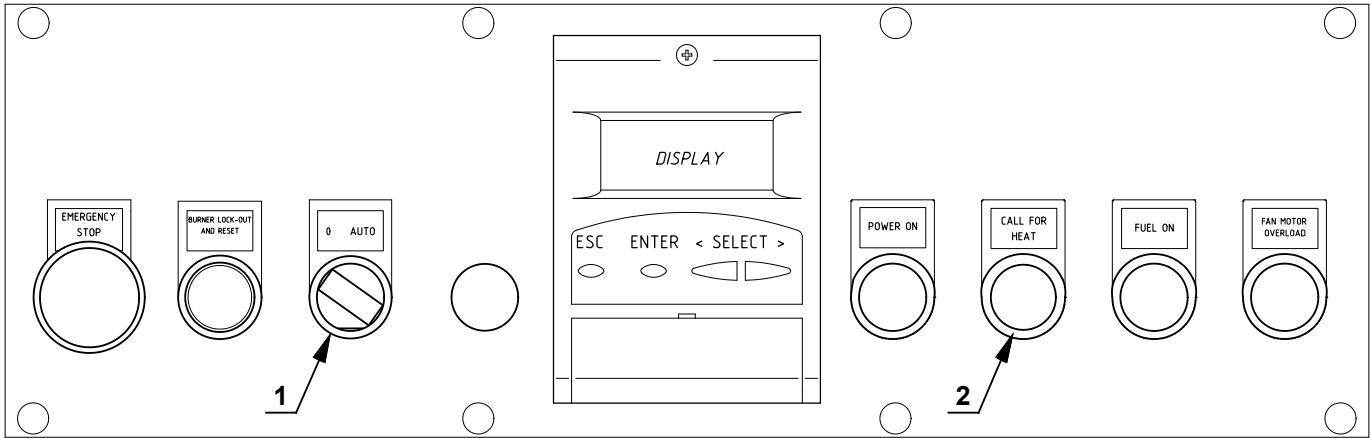

D11968

Fig. 27

5.4 Burner ignition

Once the above steps are complete, the burner should light.

If the motor starts up, but the flame does not appear and the flame control goes into lockout, reset it and wait for a new ignition attempt.

If ignition is still not achieved, it may be that gas is not reaching the combustion head within the safety time period of 3 seconds. In this case increase gas ignition delivery.

The arrival of gas at the pipe coupling is indicated by the U-type pressure gauge (Fig. 26).

If further burner lockouts occur, refer to the “Release procedure” given in the equipment manual supplied.



WARNING

In the event of a burner lockout, more than two consecutive burner reset operations could cause damage to the installation. On the third lockout, contact the Aftersales Service.



DANGER

If further lockouts or burner faults occur, interventions must only be made by qualified, authorised personnel (as indicated in this manual, and in compliance with the laws and regulations currently in force).

Once the burner has ignited, proceed with the global adjustment of the burner.

5.5 Combustion air adjustment

Fuel/combustion air synchronisation is done with the relevant servomotors (air and gas) by logging a calibration curve by means of the electronic cam.

It is advisable, to reduce the loss and for a wide calibration field, to adjust the servomotors to the maximum of the output used, the nearest possible to the maximum opening (90°).

On the gas butterfly valve, fuel step according to the burner output required, with servomotor completely open, is carried out by the pressure stabiliser placed on the gas train.

The values given in Tab. L may be used as guidelines for correctly calibrating combustion.

5.5.1 Air / gas adjustment and output modulation

The air/gas regulator and output modulation system equipping **RS** series burners performs a number of integrated functions to optimise burner function, in both individual installations and in combination with other units (e.g. double furnace boiler or multiple heat generators in parallel).

The basic system functions control:

- 1 The dosage of the air and fuel through positioning using direct servocommands of the relevant valves eliminating the possible play in the calibration systems with mechanical cam lever mechanisms, used on traditional modulating burners.
- 2 The modulation of the burner output in accordance with the load required by the system, with maintenance of the pressure or temperature of the boiler at the operating values set.
- 3 The sequence (cascade adjustment) of more than one boiler through the suitable connection of the various units and the activation of the internal software of the individual systems (option).

Further interfaces and communication functions with computers, for remote control or integration in central supervision systems are available on the basis of the configuration of the system.

EN 676		Air excess		
		Max. output. $\lambda \leq 1.2$		Min. output $\lambda \leq 1.3$
GAS	Theoretical max CO ₂ 0% O ₂	CO ₂ % Calibration		CO mg/kWh
		$\lambda = 1.2$	$\lambda = 1.3$	
G 20	11.7	9.7	9.0	≤ 100
G 25	11.5	9.5	8.8	≤ 100
G 30	14.0	11.6	10.7	≤ 100
G 31	13.7	11.4	10.5	≤ 100

Tab. L



The first start up and every further internal setting operation of the adjustment system or the expansion of the base functions require access by means of password and are to be carried out by service personnel who are especially trained for the internal programming of the instrument and the specific application created with this burner.

The first start-up and curve synchronisation manual is supplied with the burner.

At request, the complete manual for the control and setting of all parameters is available.

5.6 FGR commissioning

The flue gas recirculation (FGR) function is used to reduce the NO_x content of flue gases. This is accomplished by feeding a certain proportion of the flue gas back to the combustion chamber, causing the flame's temperature to drop. The amount of recirculated flue gas is set via auxiliary actuator 3.



When making the setting, it must be observed that excessive amounts of recirculated flue gas can cause the flame to lift off the burner's head (stability limit of flame).

NOTE:

Reduction of maximum burner output

Use of the flue gas recirculation (FGR) function or the flue gas mass introduced to the supply air duct might lower the burner's maximum output.

This means that the maximum amount of combustion air that can be introduced will be reduced.

Hence, the amount of fuel for high-fire operation must be reduced to ensure correct combustion values.

The flame control supports flue gas recirculation (FGR) function: flue gas recirculation (FGR) without temperature compensation (operating mode flue gas recirculation (FGR) = time or temperature).

With these operating principles, the positions of auxiliary actuator 3 can only change between CLOSED (ignition position) and the positions on the ratio control curves.

First time set up

Commission the plant with no influence from flue gas recirculation (FGR).

Factory preset: FGR-Mode = AUX3onCurve

Flue gas recirculation (FGR) function is deactivated.

(Auxiliary actuator 3 is driven along its parameterized ratio control curve)

This enables the fuel-air ratio control system to be set as if the plant operated without flue gas recirculation (FGR).

For that purpose, in flue gas recirculation (FGR) mode Time, set the switch-on time to its maximum or parameterize it at such a level that auxiliary actuator 3 will not be positioned until the curve settings become active.

Analogously, in flue gas recirculation (FGR) mode Temperature, set the switch-on temperature to a level that cannot be reached.

After completing the settings of the fuel-air ratio control curves without flue gas recirculation (FGR), the actual settings with an active auxiliary actuator 3 can now be made.

Since this might have an impact on the combustion settings, the fuel- and air-regulating actuators may have to be readjusted.

First time FGR set up

Modify the factory preset: FGR-Mode = time (Auxiliary actuator 3 is held in the ignition position until an adjustable time is reached).

We suggest to use a value from 5-15 minutes for first time FGR commissioning.

Check value of temperature of flue gas recirculation (FGR). It must be 120-130 °C to reduce condensation in burner or intake duct.

Operation FGR set up

Modify the factory preset: FGR-Mode = temperature (Auxiliary actuator 3 is held in the ignition position until an adjustable temperature is reached.).

After first time FGR commissioning, we suggest to use this setting using a temperature sensor in FGR duct.

We suggest to use previous value of temperature measured during first time commissioning.

In case of use the FGR-Mode = time, make sure that the flue gas temperature reaches the value within the set time.

FGR temperature sensor

FGR-Mode: PT 1000 temperature probe is connect to X11 terminal (see electrical connection)

You can connect 2 probes in X10 terminal together:

Factory pre-set:

PT100 for boiler temperature (customer installation)

PT1000 for FGR-sensor (already connected)



You can't use PT1000 probe for boiler temperature when it's used as FGR sensor. But you can use other type of connection.



Check air temperature where is mounted flame sensor.

If temperature is more than 50-60°, it's mandatory air cooling using burner air-intake.



While burner is working with FGR, it's possible reach high surface temperature.

5.7 Pressure switch adjustment

5.7.1 Air pressure switch - CO check

Adjust the air pressure switch after having performed all other burner adjustments with the air pressure switch set to the start of the scale (Fig. 28).

With the burner working at MIN output, insert a combustion analyser in the stack, slowly close the suction inlet of the fan (for example, with a piece of cardboard) until the CO value does not exceed 100 ppm.

Slowly turn the appropriate knob clockwise until the burner goes into lockout.

Check the indication of the arrow pointing upwards on the graduated scale (Fig. 28).

Turn the knob clockwise again, until the value shown on the graduated scale corresponds with the arrow pointing downwards (Fig. 28), and so recovering the hysteresis of the pressure switch (shown by the white mark on a blue background, between the two arrows).

Now check the correct start-up of the burner.

If the burner locks out again, turn the knob anti-clockwise a little bit more.



Fig. 28



Connecting the air pressure switch in differential mode, the burner will no longer be certified according to the EN 676 standard.

5.7.2 Maximum gas pressure switch

Adjust the maximum gas pressure switch (Fig. 29) after making all other burner adjustments with the maximum gas pressure switch set to the end of the scale.

To calibrate the maximum gas pressure switch, open the tap and then connect a pressure gauge to its pressure test point.

The maximum gas pressure switch must be regulated to a value no higher than 30% of the measurement read on the gauge when the burner is working at maximum output.

After making the adjustment, remove the pressure gauge and close the tap.

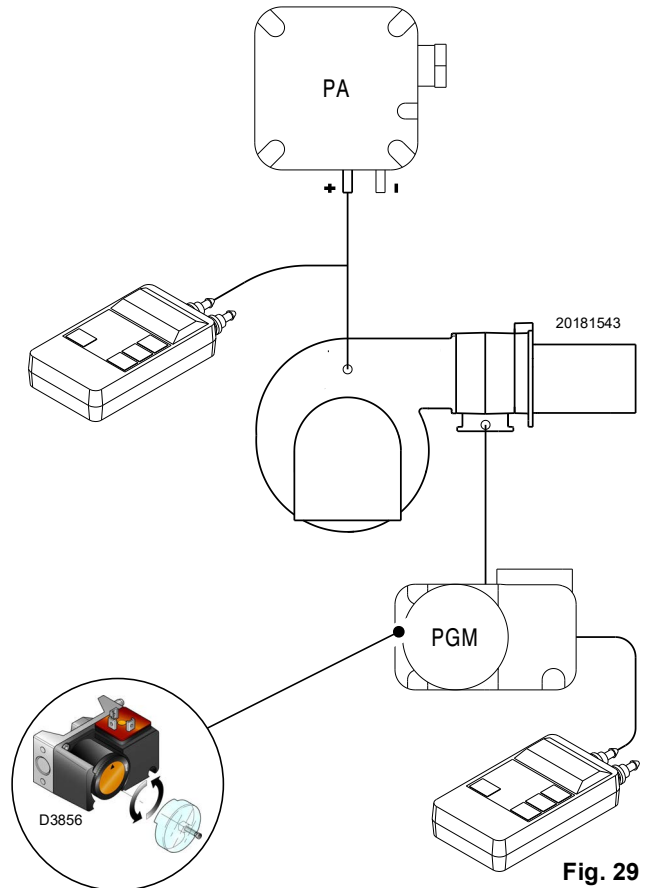

Fig. 29

5.7.3 Minimum gas pressure switch

The purpose of the minimum gas pressure switch is to prevent the burner from operating in an unsuitable way due to too low gas pressure.

Adjust the minimum gas pressure switch (Fig. 30) after having adjusted the burner, the gas valves and the gas train stabiliser. With the burner operating at maximum output:

- install a pressure gauge downstream of the gas train stabiliser (for example at the gas pressure test point on the burner combustion head);
- choke slowly the manual gas cock until the pressure gauge detects a decrease in the pressure read of about 0.1 kPa (1 mbar). In this phase, verify the CO value which must always be less than 100 mg/kWh (93 ppm).
- Increase the adjustment of the gas pressure switch until it intervenes, causing the burner shutdown;
- remove the pressure gauge and close the cock of the gas pressure test point used for the measurement;
- open completely the manual gas cock.

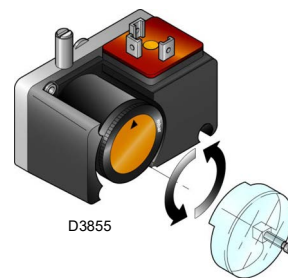

Fig. 30



1 kPa = 10 mbar

5.7.4 PVP pressure switch kit

Adjust the pressure switch for the leak detection control (PVP kit) (Fig. 31) according to the instructions supplied with the kit.

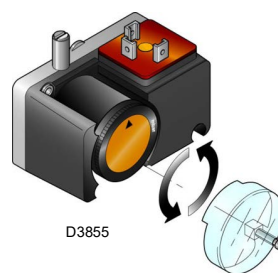





Fig. 31

5.8 Final checks (with burner operating)

<ul style="list-style-type: none"> ➤ Open the thermostat/pressure switch TL ➤ Open the thermostat/pressure switch TS 		The burner must stop
<ul style="list-style-type: none"> ➤ Turn the gas maximum pressure switch knob to the minimum end of scale position ➤ Turn the air pressure switch to the maximum end of scale position. 		The burner must stop in lockout
<ul style="list-style-type: none"> ➤ Turn off the burner and cut off the power. ➤ Disconnect the minimum gas pressure switch connector. 		The burner must not start
<ul style="list-style-type: none"> ➤ Disconnect the flame sensor wire. 		The burner must stop in lockout due to ignition failure

Tab. M



WARNING

Make sure that the mechanical locking systems on the various adjustment devices are fully tightened.

6 Maintenance

6.1 Notes on safety for the maintenance

The periodic maintenance is essential for the good operation, safety, yield and duration of the burner.

It allows you to reduce consumption and polluting emissions and to keep the product in a reliable state over time.



The maintenance interventions and the calibration of the burner must only be carried out by qualified, authorised personnel, in accordance with the contents of this manual and in compliance with the standards and regulations of current laws.

Before carrying out any maintenance, cleaning or checking operations:



Disconnect the electrical supply from the burner by means of the main system switch.



Close the fuel interception tap.



Wait for the components in contact with heat sources to cool down completely.

6.2 Maintenance programme

6.2.1 Maintenance frequency



The gas combustion system should be checked at least once a year by a representative of the manufacturer or another specialised technician.

6.2.2 Safety test - with gas ball valve closed

It is fundamental to ensure the correct execution of the electrical connections between the gas solenoid valves and the burner to perform safely the commissioning.

For this purpose, after checking that the connections have been carried out in accordance with the burner's electrical diagrams, an ignition cycle with closed gas ball valve -dry test- must be performed.

- 1 The manual ball gas valve must be closed
- 2 The electrical contacts of the burner limit switch need to be closed
- 3 Ensures closed the contact of the low gas pressure switch
- 4 Make a trial for burner ignition

The start-up cycle must be as follows:

- Starting the fan for pre-ventilation
- Performing the gas valve seal control, if provided
- Completion of pre-ventilation
- Arrival of the ignition point
- Power supply of the ignition transformer
- Electrical Supply of solenoid gas valves

Since the manual gas ball valve is closed, the burner will not light up and its flame control will go to a safety lockout condition.

The actual electrical supply of the solenoid gas valves can be verified by inserting a tester. Some valves are equipped with light signals (or close/open position indicator) that turn on at the same time as their power supply.



IF THE ELECTRICAL SUPPLY OF THE GAS VALVES OCCURS AT UNEXPECTED TIMES, DO NOT OPEN MANUAL GAS BALL VALVE, SWITCH OFF POWER LINE; CHECK THE WIRES; CORRECT THE ERRORS AND REPEAT THE COMPLETE TEST.

6.2.3 Checking and cleaning



The operator must use the required equipment during maintenance.

Combustion

Carry out an analysis of the combustion discharge gases. Significant differences with respect to the previous check indicate the points where more care should be exercised during maintenance.

Combustion head

Open the burner and make sure that all components of the combustion head are in good condition, not deformed by the high temperatures, free of impurities from the surroundings and correctly positioned.

Fan

Check to make sure that no dust has accumulated inside the fan or on its blades, as this condition will cause a reduction in the air flow rate and provoke polluting combustion.

Voltage on the flame sensor

Minimum value for correct operation: 3.5V DC (value on AZL display at about 50%).

If the value is lower, it could be due to:

- sensor not positioned correctly;
- low voltage (lower than 187V);
- bad regulation of the burner.

In order to measure, use a voltmeter with a 10V DC scale connected as in the diagram (Fig. 32).

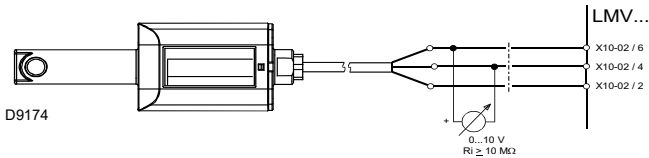

Fig. 32

Burner

Clean the outside of the burner.

Boiler

Clean the boiler as indicated in its accompanying instructions in order to maintain all the original combustion characteristics intact, especially the flue gas temperature and combustion chamber pressure.

Gas leaks

Make sure that there are no gas leaks on the pipes between the gas meter and the burner.

Gas filter

Replace the gas filter when it is dirty.

Combustion

If the combustion values found at the start of the intervention do not satisfy current standards or anyway indicate a poor state of combustion (consult the table below), contact the Technical Assistance Service for the necessary adjustments.

EN 676		Air excess		
		Max. output. $\lambda \leq 1.2$		Min. output $\lambda \leq 1.3$
GAS	Theoretical max CO ₂ 0 % O ₂	CO ₂ % Calibration		CO mg/kWh
		$\lambda = 1.2$	$\lambda = 1.3$	
G 20	11.7	9.7	9.0	≤ 100
G 25	11.5	9.5	8.8	≤ 100
G 30	14.0	11.6	10.7	≤ 100
G 31	13.7	11.4	10.5	≤ 100

Tab. N

6.2.4 Safety components

The safety components must be replaced at the end of their life cycle indicated in Tab. O. The specified life cycles do not refer to the warranty terms indicated in the delivery or payment conditions.

Safety component	Life cycle
Flame control	10 years or 250,000 operation cycles
Flame sensor	10 years or 250,000 operation cycles
Gas valves (solenoid)	10 years or 250,000 operation cycles
Pressure switches	10 years or 250,000 operation cycles
Pressure adjuster	15 years
Servomotor (electronic cam) (if present)	10 years or 250,000 operation cycles
Oil valve (solenoid) (if present)	10 years or 250,000 operation cycles
Oil regulator (if present)	10 years or 250,000 operation cycles
Oil pipes / couplings (metallic) (if present)	10 years
Fan impeller	10 years or 500,000 start-ups

Tab. O

6.3 Adjustment fan motor covering with external rpm

To calibrate the rpm sensor 6)(Fig. 33), proceed as follows:

- remove the cover 1) unscrewing the screws 2);
- unscrew or screw the nuts 3) - 5) and the rpm detection disc 4) so that its distance from the rpm sensor 6) is about 2 mm.;
- place the plate 4) on the nut 5) and fix with the lock nut 3);
- close the cover 1) by screwing the screws 2).

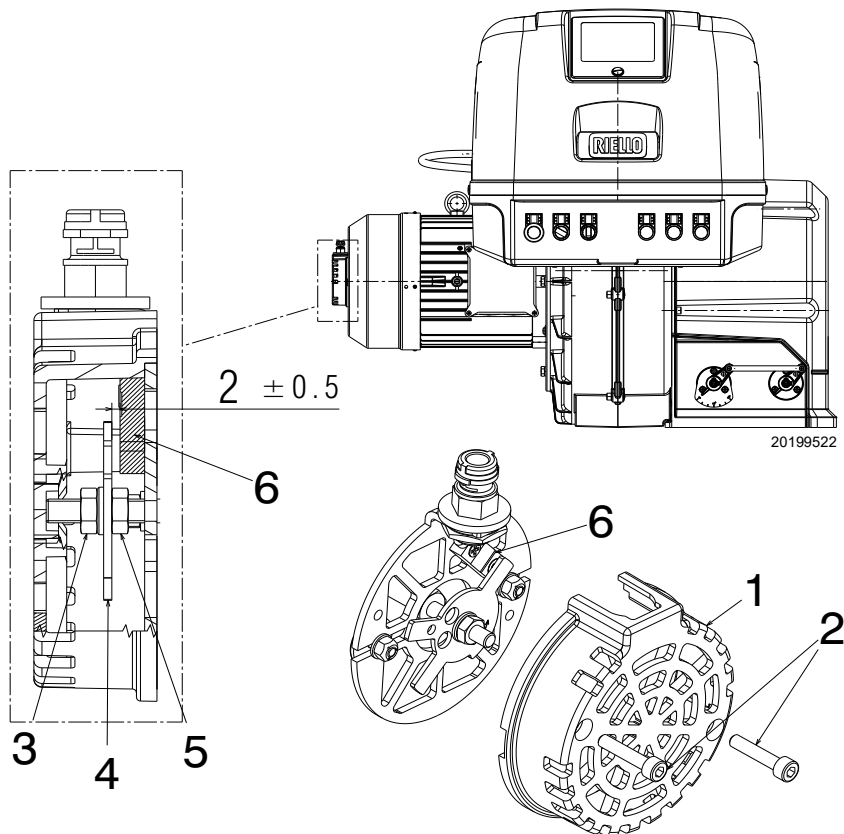

Fig. 33

Key (Fig. 33)

- 1 Cover
- 2 Screws for cover fixing
- 3 Lock nut
- 4 Rpm detection disc
- 5 Lower nut
- 6 Rpm sensor

6.4 Opening the burner



Disconnect the electrical supply from the burner by means of the main system switch;



close the fuel interception tap;



wait for the components in contact with heat sources to cool down completely;

- disconnect the FGR pipe connection;
- disconnect the socket 2)(Fig. 34) of the gas servomotor;
- remove the screws 1).

At this point, it is possible to open the burner on the hinge.

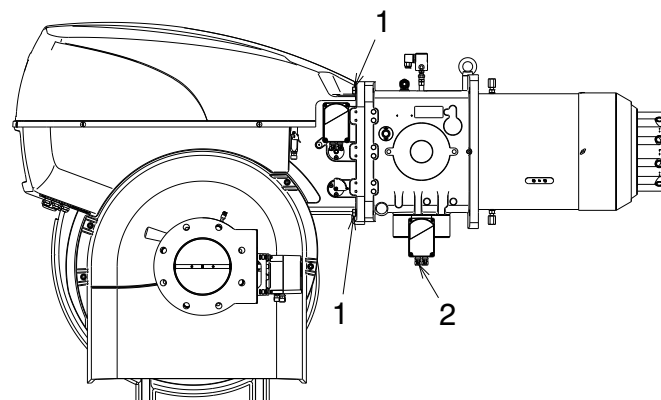
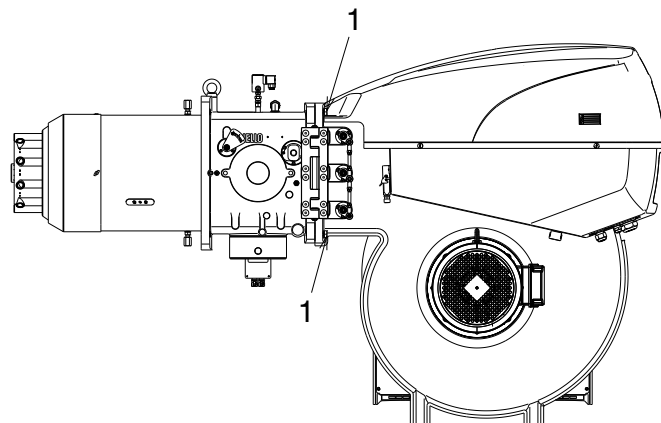

20133318

Fig. 34

6.5 Closing the burner

Refit following the steps described but in reverse order; refit all burner components as they were originally assembled.



Carry out all maintenance work and mount the casing again.

7 **Faults - Probable causes - Solutions**

If faults arise in ignition or operations, the burner performs a “safety stop”, which is signalled by the red burner lockout LED.

The display visualises alternately the lockout code and the relative diagnostic. To reset the start-up conditions, refer to the “Reset procedure” indicated in the flame control manual supplied.

When the burner starts again, the red LED goes out and the flame control is reset.

**WARNING**

In the event of a burner lockout, more than two consecutive burner reset operations could cause damage to the installation. On the third lockout, contact the Aftersales Service.

**DANGER**

If further lockouts or burner faults occur, interventions must only be made by qualified, authorised personnel (as indicated in this manual, and in compliance with the laws and regulations currently in force).

A Appendix - Accessories**Probe for checking temperature/pressure**

Parameter to be checked		Probe	
	Adjustment field	Type	Code
Temperature	- 100...+ 500°C	PT 100	3010110
Pressure	0...2.5 bar	Output probe 4....20 mA	3010213
	0...16 bar		3010214

Inverter (VSD) kit

Burner	Power supply	Inverter Output	Code
RS 1000/EV FGR	3Ph/400V/50Hz	22 kW	20163099
RS 1200/EV FGR	3Ph/400V/50Hz	30 kW	20163100

**WARNING**

The use of inverters other than those indicated by the Manufacturer may lead to burner failure and, in extreme cases, a potential risk of harm to people and damage to property.

The Manufacturing company shall not be liable for any such damage arising from non-observance of the requirements contained in this manual.

O₂ kit

Burner	Code
RS 1000/EV FGR RS 1200/EV FGR	20045187

Software interface kit

Burner	Code
RS 1000/EV FGR RS 1200/EV FGR	3010388

Soundproofing box kit

Burner	Code
RS 1000/EV FGR RS 1200/EV FGR	3010401

Gas trains in compliance with EN 676

Please refer to manual.

B Appendix - Electrical panel layout

1	Index of layouts
2	Indication of references
3	Single-wire output layout
4	Single-wire output layout
5	LMV52.... functional layout
6	LMV52.... functional layout
7	LMV52.... functional layout
8	LMV52.... functional layout
9	LMV52.... functional layout
10	LMV52.... functional layout
11	Functional layout
12	Functional layout
13	LMV52.... functional layout
14	Electrical connections set by installer
15	Electrical connections set by installer

2 Indication of references

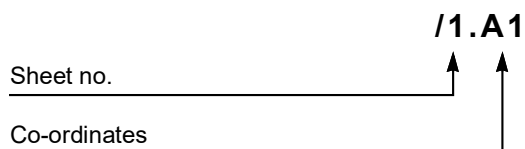

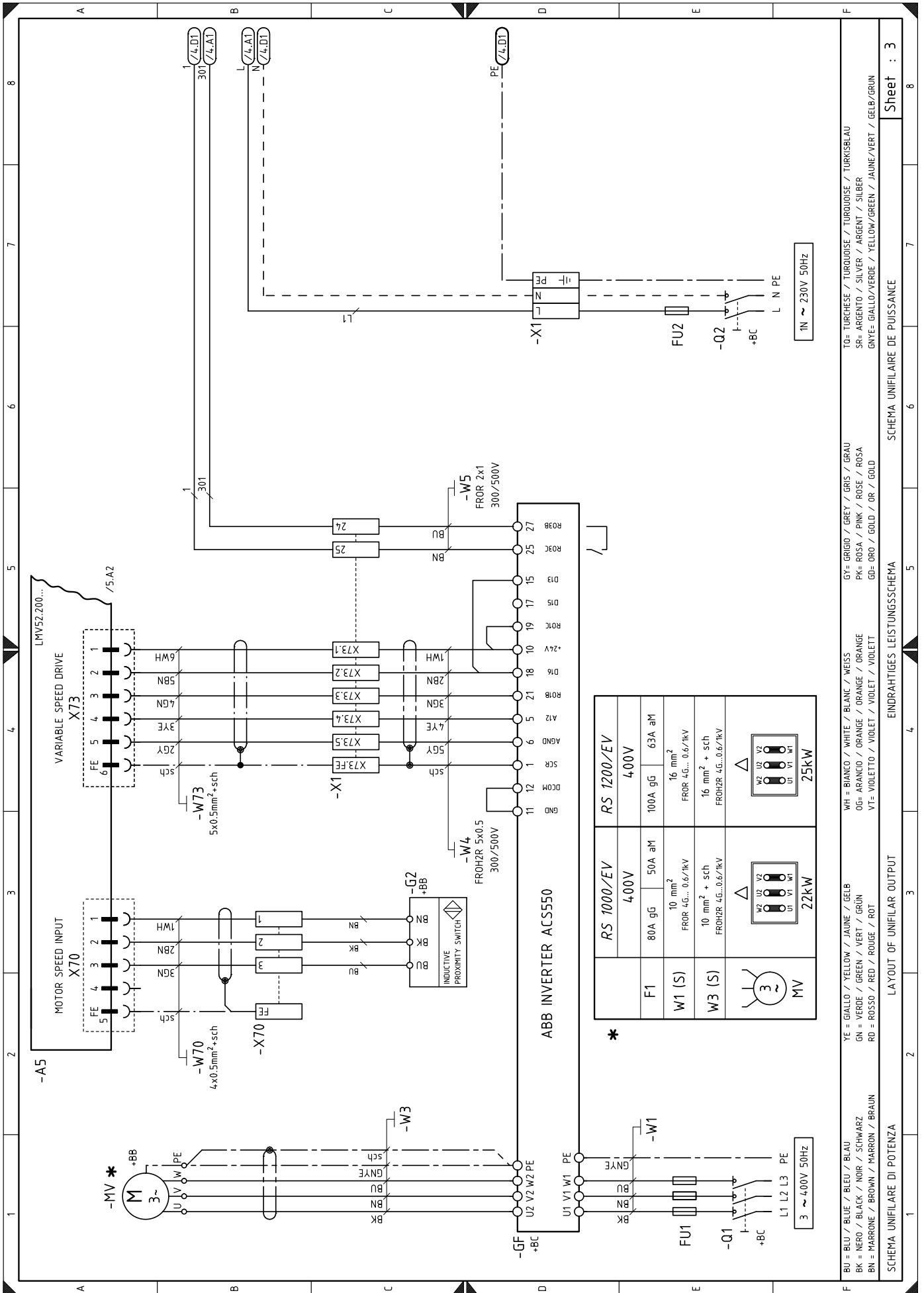

TO= TURCHESE / TURQUOISE / TURKOISE / TURKISBLAU
 SR= ARGENTO / SILVER / ARGENT / SILBER
 GNYE= GIALLO/VERDE / YELLOW/GREEN / JAUNE/VERT / GELB/GRUN

GY= GRIGIO / GREY / GRIS / GRAU
 PK= ROSA / PINK / ROSE / ROSA
 GD= ORO / GOLD / OR / GOLD

WH= BIANCO / WHITE / BLANC / WEISS
 OG= ARANCIO / ORANGE / ORANGE / ORANGE
 VT= VIOLETTA / VIOLET / VIOLET / VIOLETT

YE= GIALLO / YELLOW / JAUNE / GELB
 GN= VERDE / GREEN / VERT / GRUN
 RD= ROSSO / RED / ROUGE / ROT

BU= BLU / BLUE / BLEU / BLAU
 BK= NERO / BLACK / NOIR / SCHWARZ
 BN= MARRONE / BROWN / MARRON / BRAUN

SCHEMA UNIFILARE DI POTENZA
 LAYOUT OF UNIFILAR OUTPUT
 EINDRAHTIGES LEISTUNGSSCHEMA

SCHEMA UNIFILARE DE PUISSANCE

Sheet : 3

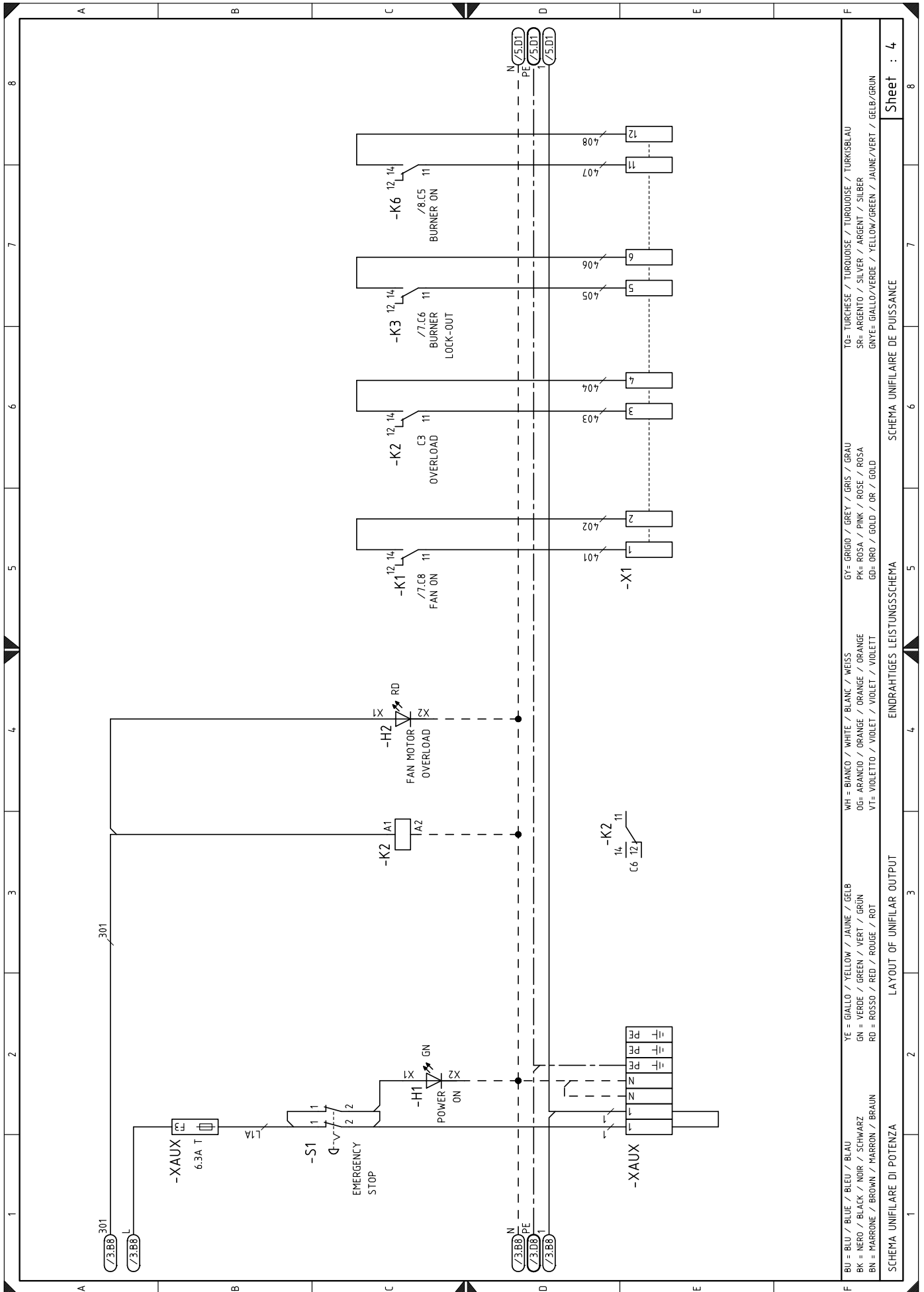

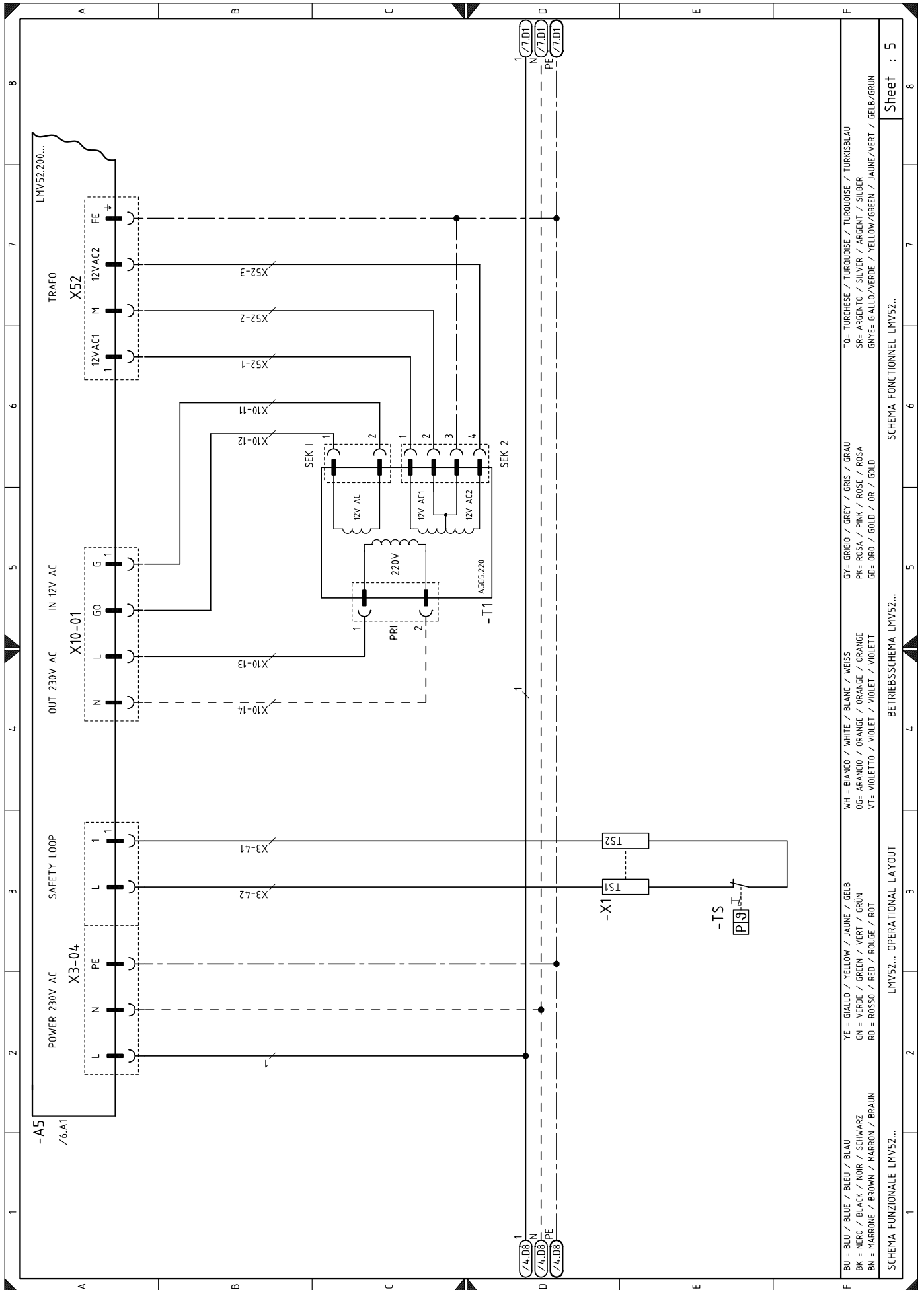

BU = BLU / BLUE / BLEU / BLAU	YE = GIALLO / YELLOW / JAUNE / GELB	WH = BIANCO / WHITE / BLANC / WEISS	GY = GRIGIO / GREY / GRIS / GRAU	TO = TURCHESE / TURQUOISE / TURKOISE / TURKISBLAU
BK = NERO / BLACK / NOIR / SCHWARZ	GN = VERDE / GREEN / VERT / GRÜN	OG = ARANCIO / ORANGE / ORANGE / ORANGE	PK = ROSA / PINK / ROSE / ROSA	SR = ARGENTO / SILVER / ARGENT / SILBER
BN = MARRONE / BROWN / MARRON / BRAUN	RD = ROSSO / RED / ROUGE / ROT	VT = VIOLETTA / VIOLET / VIOLET / VIOLETT	GD = ORO / GOLD / OR / GOLD	GNVE = GIALLO/VERDE / YELLOW/GREEN / JAUNE/VERT / GELB/GRÜN
SCHEMA FUNZIONALE LMV52... OPERATIONAL LAYOUT				
SCHEMA FONCTIONNEL LMV52... BETRIEBSSCHEMA LMV52...				
				Sheet : 5

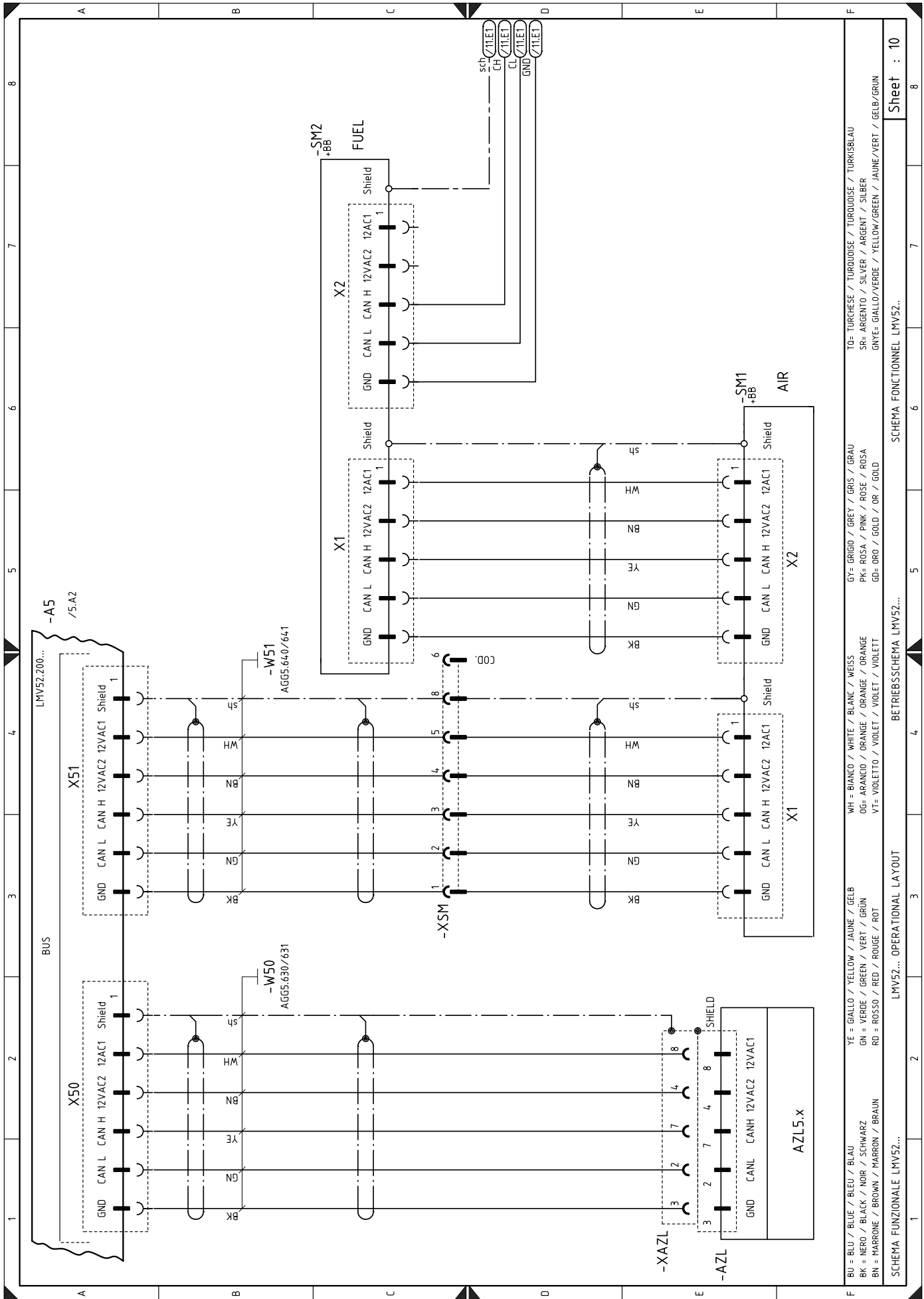

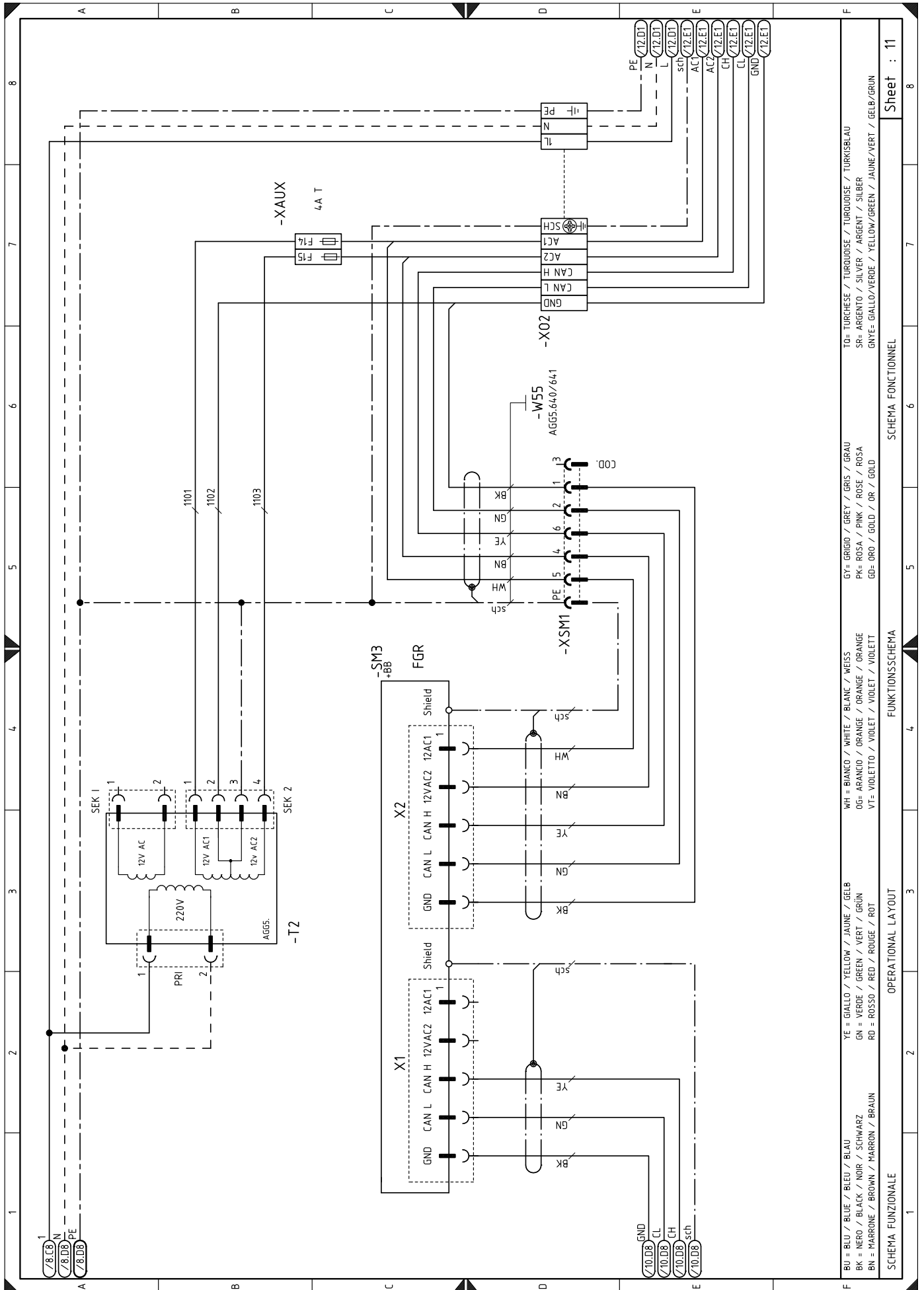

BU = BLEU / BLEU / BLAU	YE = GIALLO / YELLOW / JAUNE / GELB	WH = BIANCO / WHITE / BLANC / WEISS	GY = GRIGIO / GREY / GRIS / GRAU	TO = TURCHESE / TURQUOISE / TURKOISE / TURKISBLAU
BK = NERO / BLACK / NOIR / SCHWARZ	GN = VERDE / GREEN / VERT / GRÜN	OG = ARANCIO / ORANGE / ORANGE / ORANGE	PK = ROSA / PINK / ROSE / ROSA	SR = ARGENTO / SILVER / ARGENT / SILBER
BN = MARRONE / BROWN / MARRON / BRAUN	RD = ROSSO / RED / ROUGE / ROT	VT = VIOLETTA / VIOLET / VIOLET / VIOLETT	GD = ORO / GOLD / OR / GOLD	GNYE = GIALLO/VERDE / YELLOW/GREEN / JAUNE/VERT / GELB/GRÜN
SCHEMA FUNZIONALE	OPERATIONAL LAYOUT	FUNKTIONSSCHEMA	SCHEMA FONCTIONNEL	SCHEMA FONCTIONNEL
				Sheet : 11

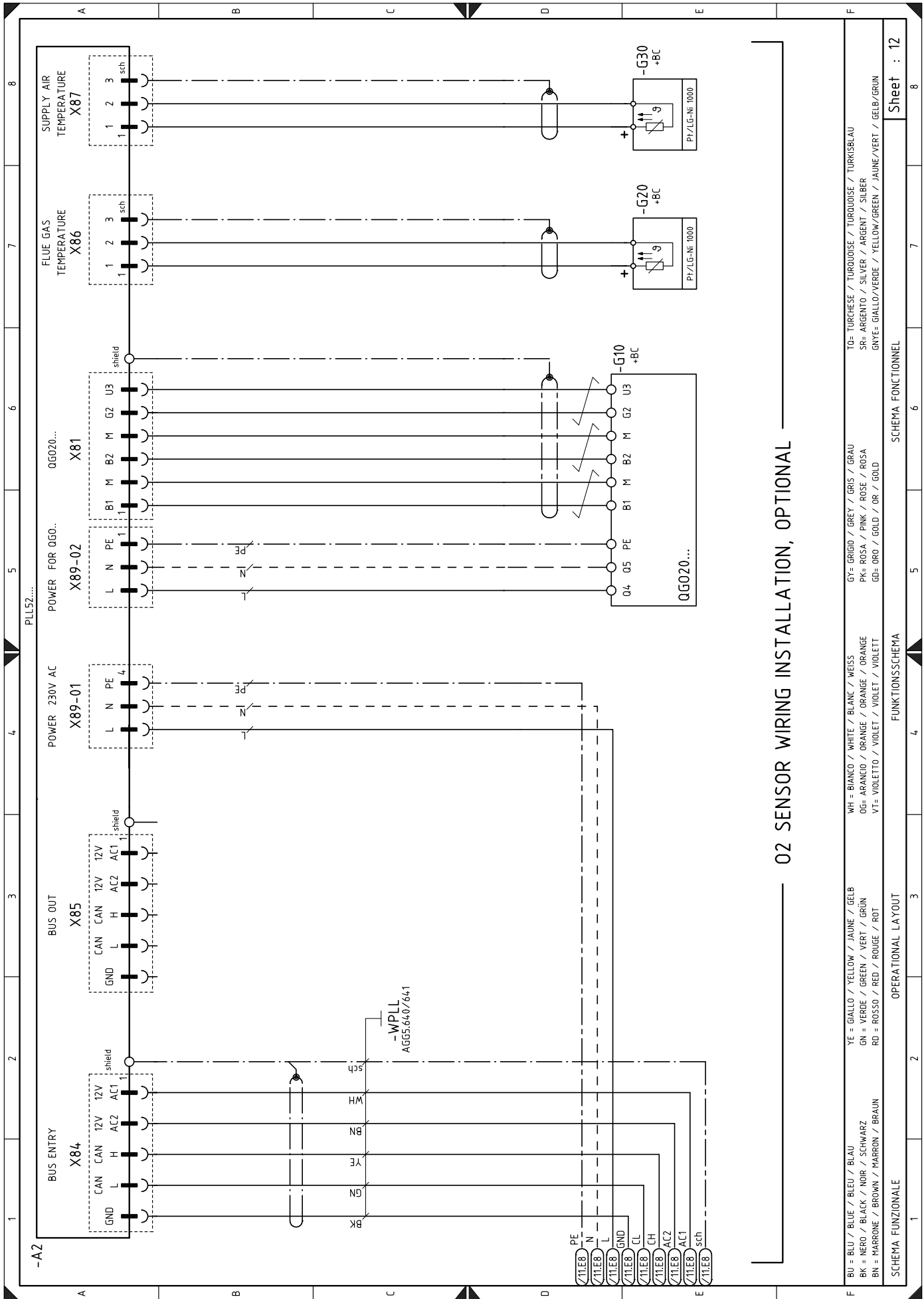

02 SENSOR WIRING INSTALLATION, OPTIONAL

Sheet : 12

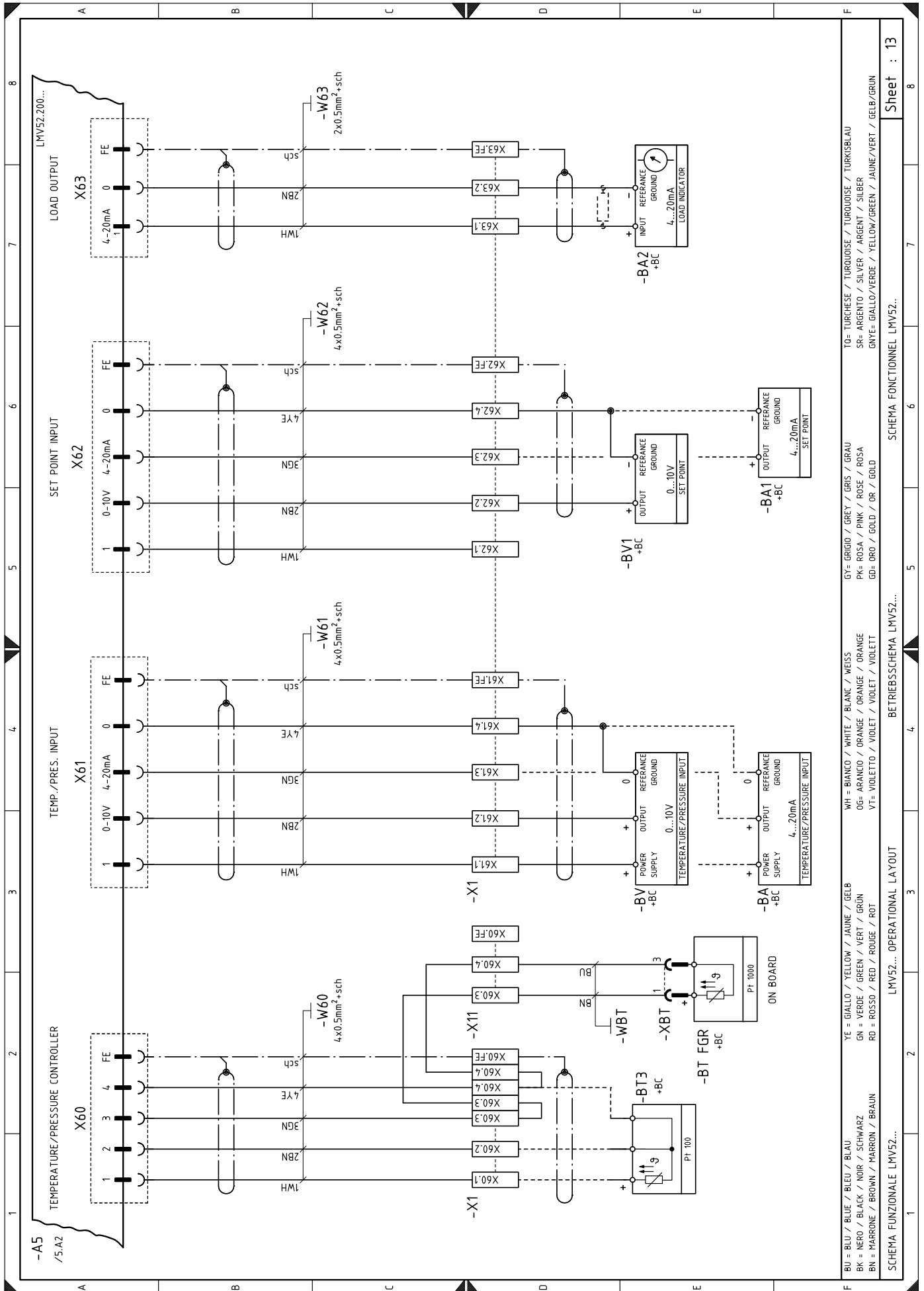

BU = BLU / BLUE / BLEU / BLAU	YE = GIALLO / YELLOW / JAUNE / GELB	WH = BIANCO / WHITE / BLANK / WEISS	GY = GRIGIO / GREY / GRIS / GRAU	TO = TURCHESE / TURQUOISE / TURKOISE / TURKISBLAU
BK = NERO / BLACK / NOIR / SCHWARZ	GN = VERDE / GREEN / VERT / GRÜN	OG = ARANCIO / ORANGE / ORANGE / ORANGE	PK = ROSA / PINK / ROSE / ROSA	SR = ARGENTO / SILVER / ARGENT / SILBER
BN = MARRONE / BROWN / MARRON / BRAUN	RD = ROSSO / RED / ROUGE / ROT	VT = VIOLETTO / VIOLET / VIOLET / VIOLETT	GD = ORO / GOLD / OR / GOLD	GNVE = GIALLO/VERDE / YELLOW/GREEN / JAUNE/VERT / GELB/GRÜN

SCHEMA FUNZIONALE LMV52... LMV52... OPERATIONAL LAYOUT BETRIEBSSCHEMA LMV52... SCHEMA FONCTIONNEL LMV52... Sheet : 13

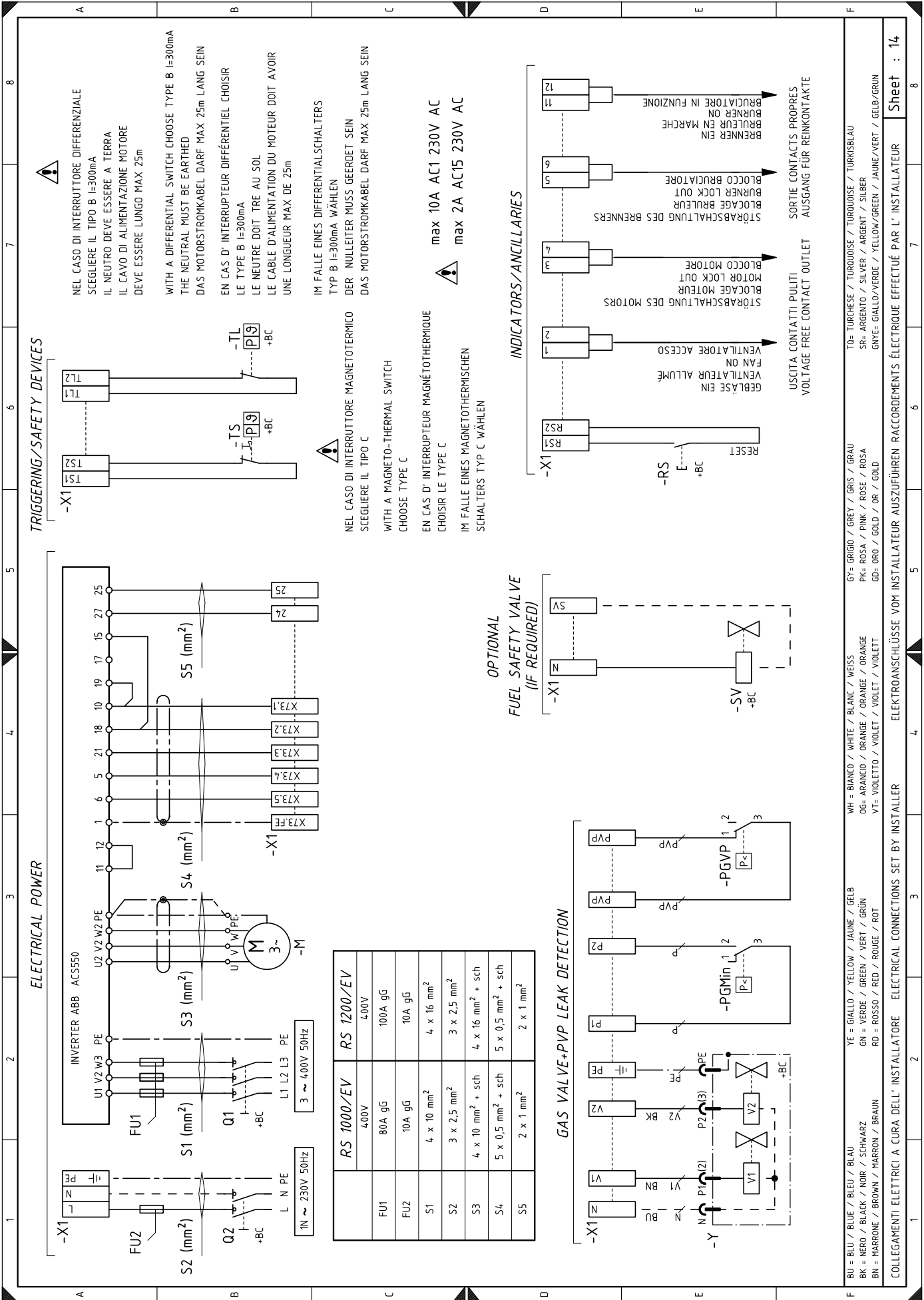

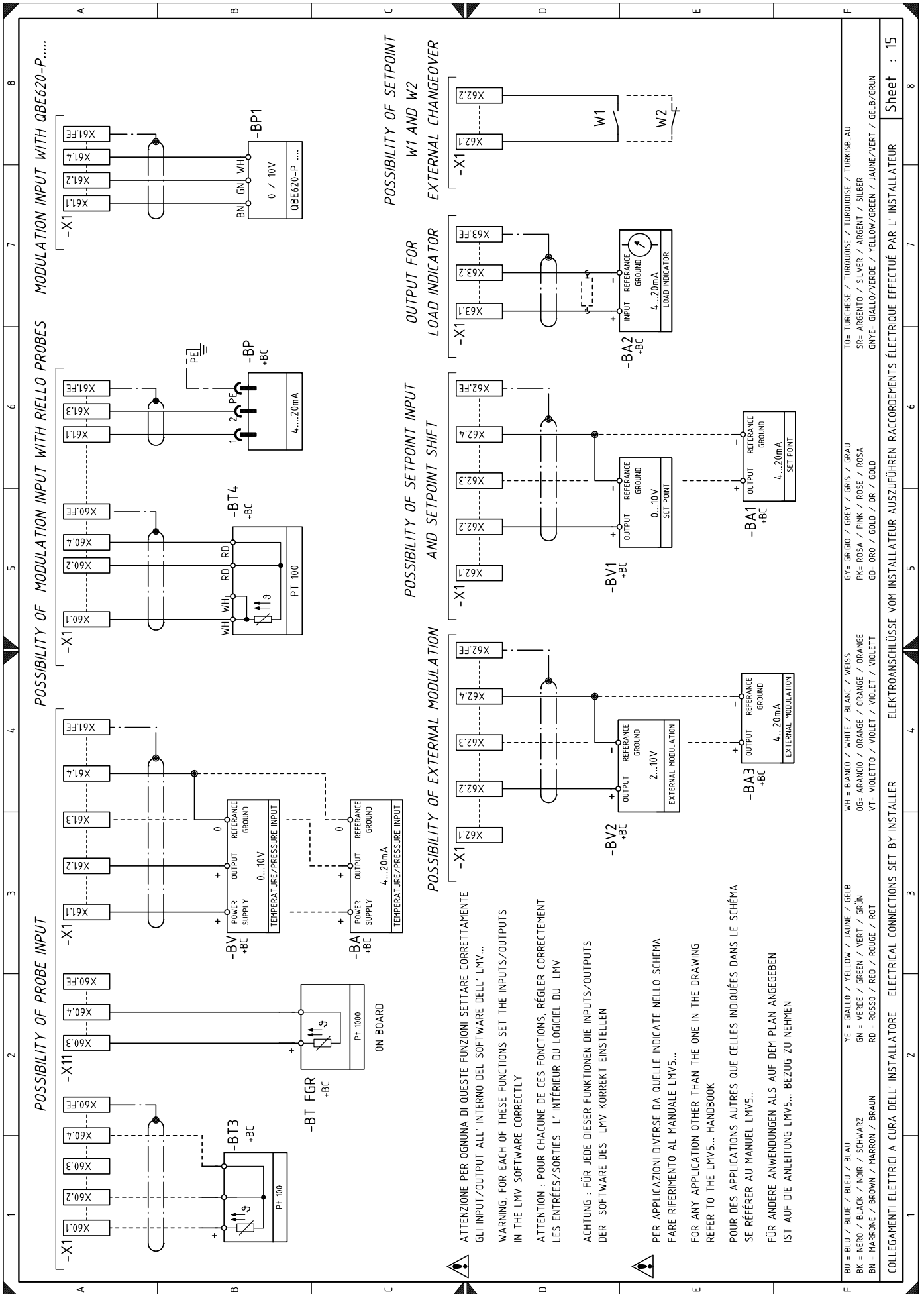

BU = BLU / BLUE / BLEU / BLAU	YE = GIALLO / YELLOW / JAUNE / GELB	WH = BIANCO / WHITE / BLANC / WEISS	GY = GRIGIO / GREY / GRIS / GRAU	TO = TURCHESE / TURKHOISE / TURKISBLAU
BK = NERO / BLACK / NOIR / SCHWARZ	GN = VERDE / GREEN / VERT / GRÜN	OG = ARANCIO / ORANGE / ORANGE / ORANGE	PK = ROSA / PINK / ROSE / ROSA	SR = ARGENTO / SILVER / ARGENT / SILBER
BN = MARRONE / BROWN / MARRON / BRAUN	RD = ROSSO / RED / ROUGE / ROT	VT = VIOLETTO / VIOLET / VIOLET / VIOLETT	GD = ORO / GOLD / OR / GOLD	GNYE = GIALLO/VERDE / YELLOW/GREEN / JAUNE/VERT / GELB/GRÜN

Sheet : 15

Wiring layout key

A2	PLL52 operator panel	XAUX	Auxiliary terminal board
A5	Flame control	XAZL	AZL display connector
AZL	Display for flame control	XBT	Flue gases air temperature control socket
BA	Probe with output under current	XO2	Terminal board for O2 kit
BA1	Device with output undercurrent, for modifying remote setpoint	XPGM	Maximum gas pressure switch connector
BA2	Load indicator with input under current	XS	Flame sensor connector
BA3	Device with output under current for remote modulation	XSM	Servomotor connector
BP	Pressure probe	XSM1	Servomotor connector
BP1	Pressure probe	XVP1	VP1 connector
BT FGR	Probe Pt1000, 2 wires	XVP2	VP2 connector
BT3	Probe Pt100, 3 wires	Y	Gas adjustment valve + gas safety valve
BV	Output probe in voltage		
BV1	Output device in voltage to modify remote setpoint		
BV2	Device with voltage current output for remote modulation		
F14	Auxiliary fuse for servomotor transformer		
F15	Auxiliary fuse for servomotor transformer		
F3	Auxiliary fuse		
FU1	Fuses for three-phase line		
FU2	Fuses for single-phase line		
G2	RPM sensor		
G10	O2 sensor, OGO20... type		
G20	Flue gases air temperature control probe		
G30	Air temperature control probe		
GF	Inverter		
H1	Light signalling burner on		
H2	Fan motor lockout warning lamp		
H3	Heat request lighting signal		
H4	Fuel supply light signal		
K1	Clean contacts output relay for fan ON		
K2	Clean contacts output relay for motor lockout		
K3	Clean contacts output relay for burner lockout		
K6	Clean contacts output relay		
MV	Fan motor		
PA	Air pressure switch		
PE	Burner earth		
PGMax	Maximum gas pressure switch		
PGMin	Minimum gas pressure switch		
PGVP	Pilot valves gas pressure switch		
Q1	Switch/breaker for three-phase line		
Q2	Switch/breaker for single-phase line		
QRI	Flame sensor		
RS	Remote burner reset button		
S1	Emergency stop button		
S2	"0 / AUTO" selector		
SH3	Burner reset button and lockout signal		
SM1	Air servomotor		
SM2	Gas servomotor		
SM3	FGR servomotor		
SV	External safety valve		
T1	flame control transformer		
T2	Servomotor transformer		
TA	Ignition transformer		
TL	Limit thermostat/pressure switch		
TS	Safety thermostat/pressure switch		
VP1	Pilot valve 1		
VP2	Pilot valve 2		
X1	Main terminal supply board		
X11	Terminal board for FGR kit probe		
X70	Terminal board for RPM sensor		

RIELLO

RIELLO S.p.A.
I-37045 Legnago (VR)
Tel: +39.0442.630111
[http:// www.riello.it](http://www.riello.it)
[http:// www.riello.com](http://www.riello.com)