

GB **Forced draught gas burners**

Modulating operation

CE

**UK
CA**

EAC

CODE	MODEL	TYPE
20166004	RS 310/EV O2 BLU	1138T2
20174935	RS 410/EV O2 BLU	1135T2
20174936	RS 510/EV O2 BLU	1136T2
20174937	RS 610/EV O2 BLU	1137T2



Translation of the original instructions

1	Information and general warnings.....	3
1.1	Information about the instruction manual	3
1.1.1	Introduction.....	3
1.1.2	General dangers.....	3
1.1.3	Other symbols	3
1.1.4	Delivery of the system and the instruction manual	4
1.2	Guarantee and responsibility.....	4
2	Safety and prevention.....	5
2.1	Introduction.....	5
2.2	Personnel training	5
3	Technical description of the burner	6
3.1	Burner designation	6
3.2	Models available.....	6
3.3	Burner categories - Countries of destination	7
3.4	Technical data	7
3.5	Electrical data.....	7
3.6	Maximum dimensions.....	8
3.7	Firing rates	9
3.8	Test boiler.....	10
3.9	Burner equipment.....	10
3.10	Burner description	11
3.11	Electrical panel description.....	12
3.12	Flame control LMV52...).....	13
3.13	Actuator	15
3.14	PLL52... module (optional)	16
3.14.1	Terminal ratings, cable lengths and cross-sectional areas	16
3.15	Oxygen sensor QGO20 ... (optional).....	17
3.15.1	Technical data QGO20.....	18
4	Installation	19
4.1	Notes on safety for the installation	19
4.2	Handling	19
4.3	Preliminary checks	19
4.4	Operating position	20
4.5	Preparing the boiler	20
4.5.1	Boring the boiler plate	20
4.5.2	Blast tube length.....	20
4.6	Securing the burner to the boiler	20
4.7	Access to head internal part.....	21
4.8	Probe-electrode position	22
4.9	Gas butterfly valve.....	22
4.10	Combustion head adjustment.....	23
4.11	Gas pressures	24
4.11.1	Gas feeding line (Example) - Please refer to the gas train documentation for more information	24
4.11.2	Gas train	25
4.11.3	Gas train installation	25
4.11.4	Gas pressure	26
4.12	Electrical wiring	27
4.12.1	Supply cables and external connections passage	28
5	Start-up, calibration and operation of the burner	29
5.1	Notes on safety for the first start-up	29
5.2	Adjustments prior to ignition	29
5.3	Burner start-up	30

5.4	Air / fuel adjustment	31
5.4.1	Air adjustment for maximum output	31
5.4.2	Air/fuel adjustment and output modulation system	31
5.4.3	Burner adjustment.....	31
5.4.4	Output upon ignition	31
5.4.5	Maximum output	31
5.4.6	Minimum output	31
5.5	Final adjustment of the pressure switches	32
5.5.1	Air pressure switch.....	32
5.6	Pressure switch adjustment	33
5.6.1	Maximum gas pressure switch.....	33
5.6.2	Minimum gas pressure switch.....	33
5.6.3	PVP pressure switch kit	33
5.7	Operation	34
5.8	Ignition failure.....	34
5.9	Burner flame goes out during operation.....	34
5.10	Stopping of the burner	34
5.11	Final checks (with burner operating).....	34
5.12	Description of O2 trim control (optional)	35
5.12.1	Operating principle of O2 trim control	35
6	Maintenance	36
6.1	Notes on safety for the maintenance	36
6.2	Maintenance programme	36
6.2.1	Maintenance frequency.....	36
6.2.2	Safety test - with gas ball valve closed	36
6.2.3	Checking and cleaning.....	36
6.2.4	Safety components	37
6.2.5	Measuring the ionisation current.....	37
6.2.6	Checking the air and gas pressure on the combustion head	37
6.3	Checking the position of the rpm sensor.....	38
6.4	Opening the burner	39
6.5	Closing the burner.....	39
A	Appendix - Accessories	40
B	Appendix - Electrical panel layout.....	42

1 Information and general warnings

1.1 Information about the instruction manual

1.1.1 Introduction

The instruction manual supplied with the burner:

- is an integral and essential part of the product and must not be separated from it; it must therefore be kept carefully for any necessary consultation and must accompany the burner even if it is transferred to another owner or user, or to another system. If the manual is lost or damaged, another copy must be requested from the Technical Assistance Service of the area;
- is designed for use by qualified personnel;
- offers important indications and instructions relating to the installation safety, start-up, use and maintenance of the burner.

Symbols used in the manual

In some parts of the manual you will see triangular DANGER signs. Pay great attention to these, as they indicate a situation of potential danger.

1.1.2 General dangers

The **dangers** can be of **3 levels**, as indicated below.



Maximum danger level!
This symbol indicates operations which, if not carried out correctly, cause serious injury, death or long-term health risks.



This symbol indicates operations which, if not carried out correctly, may cause serious injury, death or long-term health risks.



This symbol indicates operations which, if not carried out correctly, may cause damage to the machine and/or injury to people.

1.1.3 Other symbols



DANGER: LIVE COMPONENTS
This symbol indicates operations which, if not carried out correctly, lead to electric shocks with lethal consequences.



DANGER: FLAMMABLE MATERIAL
This symbol indicates the presence of flammable materials.



DANGER: BURNING
This symbol indicates the risks of burns due to high temperatures.



DANGER: CRUSHING OF LIMBS
This symbol indicates the presence of moving parts: danger of crushing of limbs.



WARNING: MOVING PARTS
This symbol indicates that you must keep limbs away from moving mechanical parts; danger of crushing.



DANGER: EXPLOSION

This symbol signals places where an explosive atmosphere may be present. An explosive atmosphere is defined as a mixture - under atmospheric conditions - of air and flammable substances in the form of gases, vapours, mist or dust in which, after ignition has occurred, combustion spreads to the entire unburned mixture.



PERSONAL PROTECTION EQUIPMENT

These symbols indicate the equipment that must be worn and kept by the operator for protection against threats against safety and/or health while at work.



OBLIGATION TO ASSEMBLE THE COVER AND ALL THE SAFETY AND PROTECTION DEVICES

This symbol signals the obligation to reassemble the cover and all the safety and protection devices of the burner after any maintenance, cleaning or checking operations.



ENVIRONMENTAL PROTECTION

This symbol gives indications for the use of the machine with respect for the environment.



IMPORTANT INFORMATION

This symbol indicates important information that you must bear in mind.



This symbol indicates important information that you must bear in mind.

IMPORTANT

- This symbol indicates a list.

Abbreviations used

Ch.	Chapter
Fig.	Figure
Page	Page
Sec.	Section
Tab.	Table

1.1.4 Delivery of the system and the instruction manual

When the system is delivered, it is important that:

- the instruction manual is delivered to the user by the system manufacturer, with the recommendation to keep it in the room where the heat generator is to be installed.
- The instruction manual shows:
 - the serial number of the burner;

.....

- the address and telephone number of the nearest Assistance Centre.

.....

- The system supplier must carefully inform the user about:
 - the use of the system;
 - any further tests that may be required before activating the system;
 - maintenance, and the need to have the system checked at least once a year by a representative of the manufacturer or another specialised technician. To ensure a periodic check, the manufacturer recommends the drawing up of a Maintenance Contract.

1.2 Guarantee and responsibility

The manufacturer guarantees its new products from the date of installation, in accordance with the regulations in force and/or the sales contract. At the moment of the first start-up, check that the burner is integral and complete.



WARNING

Failure to observe the information given in this manual, operating negligence, incorrect installation and carrying out of non authorised modifications will result in the annulment by the manufacturer of the guarantee that it supplies with the burner.

In particular, the rights to the guarantee and the responsibility will no longer be valid, in the event of damage to things or injury to people, if such damage/injury was due to any of the following causes:

- incorrect installation, start-up, use and maintenance of the burner;
- improper, incorrect or unreasonable use of the burner;
- intervention of unqualified personnel;
- carrying out of unauthorised modifications on the equipment;
- use of the burner with safety devices that are faulty, incorrectly applied and/or not working;
- installation of untested supplementary components on the burner;
- powering of the burner with unsuitable fuels;
- faults in the fuel supply system;
- continuation of use of the burner when a fault has occurred;
- repairs and/or overhauls incorrectly carried out;
- modification of the combustion chamber with inserts that prevent the regular development of the structurally established flame;
- insufficient and inappropriate surveillance and care of those burner components most likely to be subject to wear and tear;
- use of non-original components, including spare parts, kits, accessories and optional;
- force majeure.

The manufacturer furthermore declines any and every responsibility for the failure to observe the contents of this manual.

2 Safety and prevention

2.1 Introduction

The burners have been designed and built in compliance with current regulations and directives, applying the known technical rules of safety and envisaging all the potential danger situations. It is necessary, however, to bear in mind that the imprudent and clumsy use of the equipment may lead to situations of death risk for the user or third parties, as well as the damaging of the burner or other items. Inattention, thoughtlessness and excessive confidence often cause accidents; the same applies to tiredness and sleepiness.

It is a good idea to remember the following:

- The burner must only be used as expressly described. Any other use should be considered improper and therefore dangerous.

In particular:

it can be applied to boilers operating with water, steam, diathermic oil, and to other uses expressly foreseen by the manufacturer;

the type and pressure of the fuel, the voltage and frequency of the electrical power supply, the minimum and maximum deliveries for which the burner has been regulated, the pressurisation of the combustion chamber, the dimensions of the combustion chamber and the room temperature must all be within the values indicated in the instruction manual.

- Modification of the burner to alter its performance and destinations is not allowed.
- The burner must be used in exemplary technical safety conditions. Any disturbances that could compromise safety must be quickly eliminated.
- Opening or tampering with the burner components is not allowed, apart from the parts requiring maintenance.
- Only those parts envisaged by the manufacturer can be replaced.



The manufacturer guarantees safety and proper functioning only if all burner components are intact and positioned correctly.

2.2 Personnel training

The user is the person, body or company that has acquired the machine and intends to use it for the specific purpose. He is responsible for the machine and for the training of the people working around it.

The user:

- undertakes to entrust the machine exclusively to suitably trained and qualified personnel;
- undertakes to inform his personnel in a suitable way about the application and observance of the safety instructions. With that aim, he undertakes to ensure that everyone knows the use and safety instructions for his own duties;
- Personnel must observe all the danger and caution indications shown on the machine.
- Personnel must not carry out, on their own initiative, operations or interventions that are not within their province.
- Personnel must inform their superiors of every problem or dangerous situation that may arise.
- The assembly of parts of other makes, or any modifications, can alter the characteristics of the machine and hence compromise operating safety. The manufacturer therefore declines any and every responsibility for any damage that may be caused by the use of non-original parts.

In addition:



- must take all the measures necessary to prevent unauthorised people gaining access to the machine;
- the user must inform the manufacturer if faults or malfunctioning of the accident prevention systems are noticed, along with any presumed danger situation;
- personnel must always use the personal protective equipment envisaged by legislation and follow the indications given in this manual.

3 Technical description of the burner

3.1 Burner designation

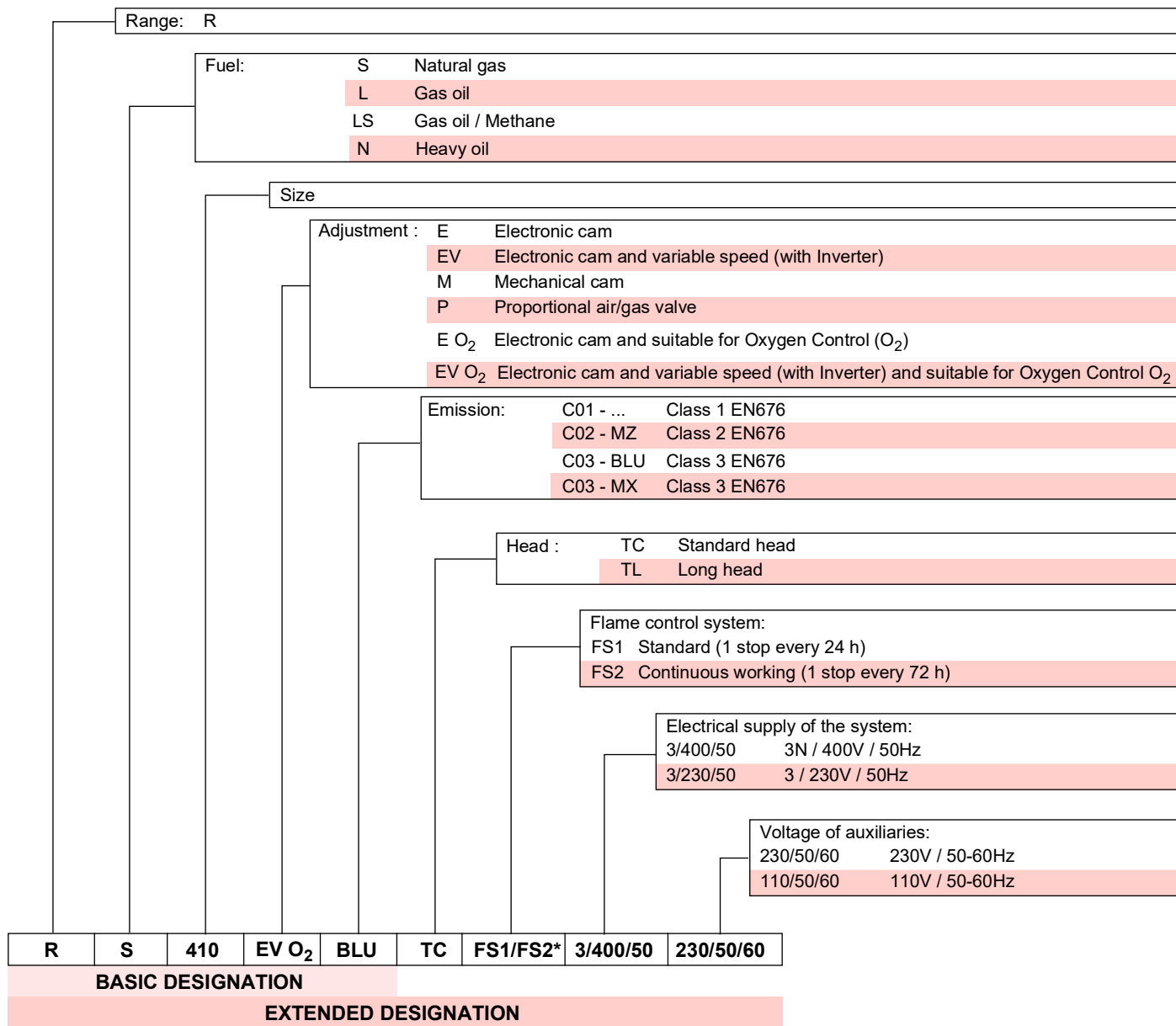

*The burner leaves the factory set up for FS1 operation. If FS2 operation is required, refer the specific manual to LMV 5...

3.2 Models available

Designation		Voltage	Start-up	Code
RS 310/EV O2 BLU FS1/FS2	TC	3/400/50	Inverter	20166004
RS 410/EV O2 BLU FS1/FS2	TC	3/400/50	Inverter	20174935
RS 510/EV O2 BLU FS1/FS2	TC	3/400/50	Inverter	20174936
RS 610/EV O2 BLU FS1/FS2	TC	3/400/50	Inverter	20174937

Tab. A

3.3 Burner categories - Countries of destination

Gas category	Destination country
I2E	LU - PL
I2E(R)	BE
I2EK	NL
I2ELL	DE
I2Er	FR
I2H	AT-BG-CH-CZ-DK-EE-ES-FI-GB-GR-HU-IE-IS-IT-LT-LV-NO-PT-RO-SE-SI-SK-TR

Tab. B

3.4 Technical data

Model	RS 310/EV O2 BLU RS 410/EV O2 BLU RS 510/EV O2 BLU RS 610/EV O2 BLU					
Power ⁽¹⁾ Delivery ⁽¹⁾	min - max	kW	400/1200 - 3630	500/1500 ÷ 4450	650/1800 ÷ 5250	780/2200 ÷ 6250
Fuels	Natural gas: G20 (methane gas) - G25					
Operation*	FS1: Intermittent (min. 1 stop in 24 hours) - FS2: Continuous (min. 1 stop in 72 hours)					
Standard applications	Boilers: water, steam, diathermic oil					
Ambient temperature		°C	0 - 50			
Combustion air temperature		°C max	60			
Noise levels ⁽²⁾	Sound pressure	dB(A)	78	80	82.5	85
	Sound power		89	91	93.5	96
CE	CE-0476DP3335					
Weight	250				280	

Tab. C

- (1) Reference conditions: Ambient temperature 20°C - Gas temperature 15°C - Barometric pressure 1013 mbar - Altitude 0 m a.s.l.
 (2) Sound pressure measured in manufacturer's combustion laboratory, with burner operating on test boiler and at maximum rated output. The sound power is measured with the "Free Field" method, as per EN 15036, and according to an "Accuracy: Category 3" measuring accuracy, as set out in EN ISO 3746.

3.5 Electrical data

Model	RS 310/EV O2 BLU RS 410/EV O2 BLU RS 510/EV O2 BLU RS 610/EV O2 BLU				
Main electrical supply	3N ~ 400V +/-10% 50 Hz				
Absorbed electrical power	kW max	9.1	10.8	14	17
Protection level	IP 54				

Tab. D



*The burner leaves the factory set up for FS1 operation. If FS2 operation is required, refer the specific manual to LMV 5...

3.6 Maximum dimensions

The maximum dimensions of the burner are given in Fig. 1.
 Bear in mind that inspection of the combustion head requires the burner to be opened and the rear part turned on the hinge.
 The maximum dimensions of the open burner are indicated by the A and R positions.

The I position is reference for the refractory thickness of the boiler door.



* The gas adaptor is set also for DN 80 bore.

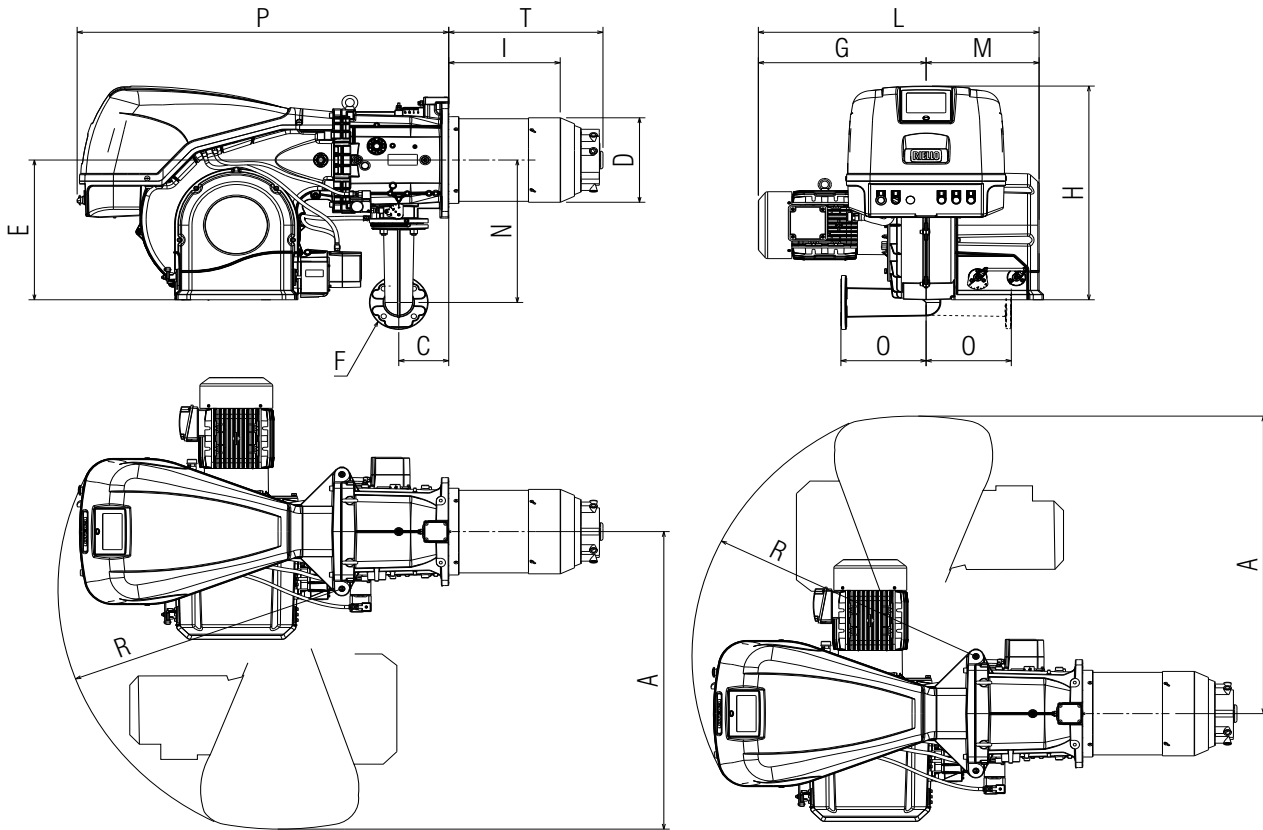

20180807

Fig. 1

mm	A	C	D	E	F*	G	H	I	L	M	N	O	P	R	T
RS 310/EV O2 BLU	1090	178	306	520	DN65	500	790	446	900	400	528	290	1260	966	565
RS 310/EV O2 BLU	1090	178	306	520	DN65	500	790	346	900	400	528	290	1260	966	465
RS 410/EV O2 BLU	1090	178	313	520	DN65	540	790	340	940	400	528	290	1260	966	517
RS 510/EV O2 BLU	1090	178	313	520	DN65	540	790	340	940	400	528	290	1260	966	517
RS 610/EV O2 BLU	1090	178	334	520	DN65	545	790	365	945	400	528	290	1260	966	517

Tab. E

3.7 Firing rates

The **MAXIMUM OUTPUT** is chosen from within the diagram area (Fig. 2).

The **MINIMUM OUTPUT** must not be lower than the minimum limit of the diagram:



The firing rate value (Fig. 2) has been obtained considering an ambient temperature of 20 °C, an atmospheric pressure of 1013 mbar (approx. 0 m a.s.l.), and with the combustion head adjusted as shown on page 23.

Model	kW
RS 310/EV O2 BLU	400
RS 410/EV O2 BLU	500
RS 510/EV O2 BLU	650
RS 610/EV O2 BLU	780

Tab. F

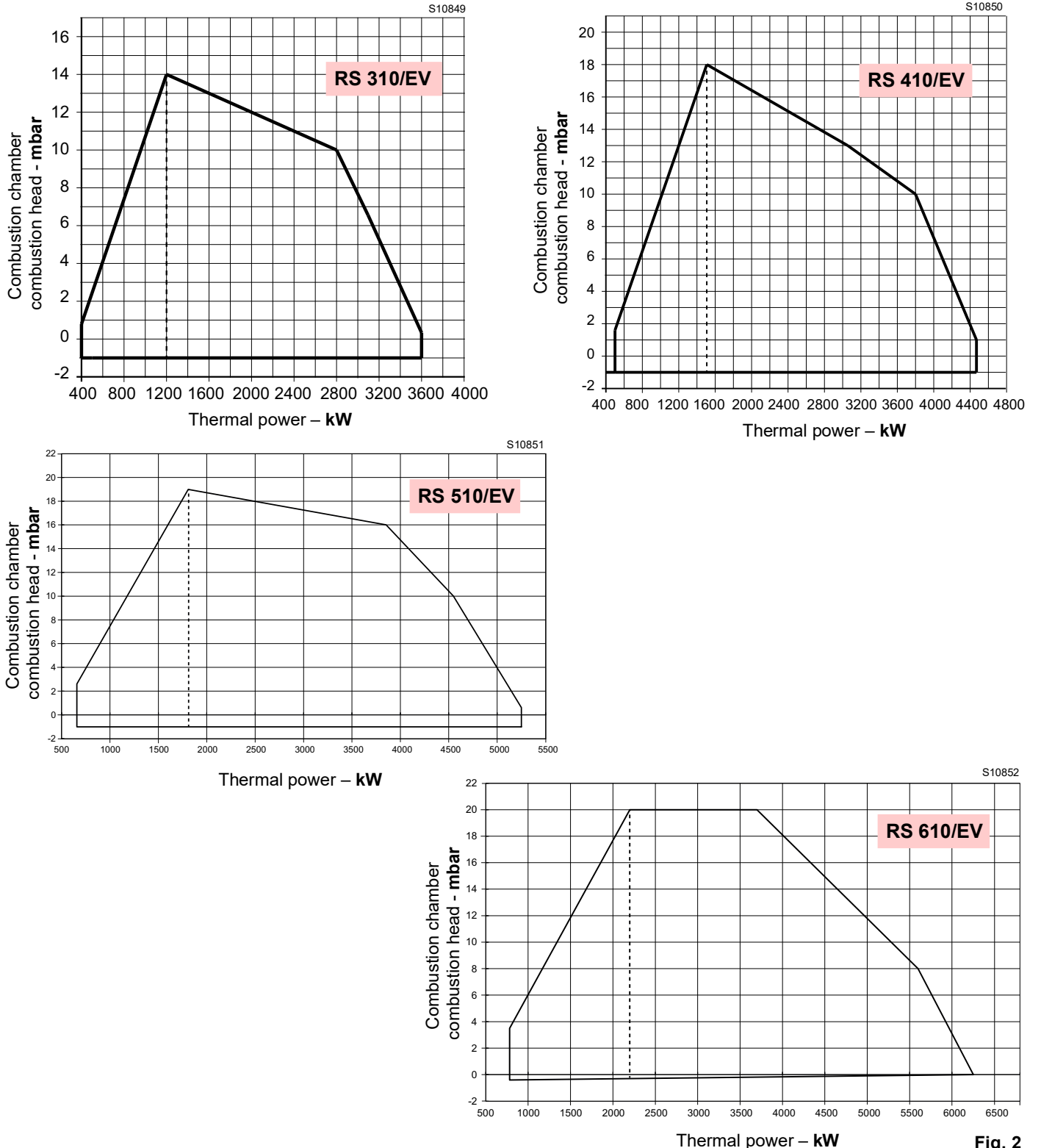

Fig. 2

3.8 Test boiler

The burner/boiler combination does not pose any problems if the boiler is EC approved and its combustion chamber dimensions are similar to those indicated in the diagram (Fig. 3).

If the burner must be combined with a boiler that has not been EC approved and/or its combustion chamber dimensions are clearly smaller than those indicated in the diagram, consult the manufacturer.

The firing rates were set in relation to special test boilers, according to EN 676 regulations.

In Fig. 3 you can see the diameter and length of the test combustion chamber.

Example: RS 510/EV O2 BLU

Output 5000 kW - diameter 100 cm - length 5m

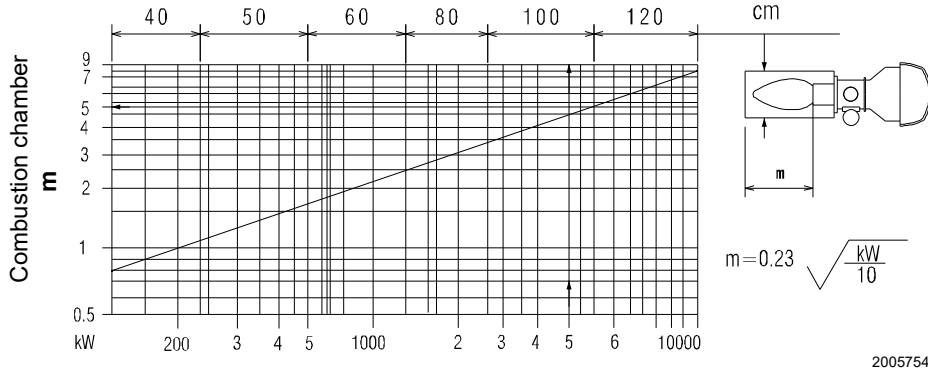

Fig. 3

3.9 Burner equipment

- Gasket for gas train adaptor. No. 1
- Adaptor for gas train. No. 1
- Screws for fixing the gas train adaptor: M 16 x 70 No. 4
- Thermal insulation screen No. 1
- M 18 x 60 screws to secure the burner flange to the boiler . No. 4
- Cable grommets kit for optional electrical wiring input. . . . No. 1
- M16 nuts to fix the gas elbow to the pipe coupling No. 4
- Spare parts list No. 1
- Instructions No. 1



It is recommended to tighten the screws of the gas flange with a tightening torque of **40 Nm ±10%**.

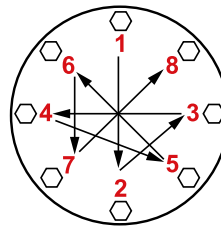

Tighten the nuts gradually (first to 30%, then to 60% up to 100%) according to the cross pattern shown in the figure.

3.10 Burner description

ASSEMBLY VIEW

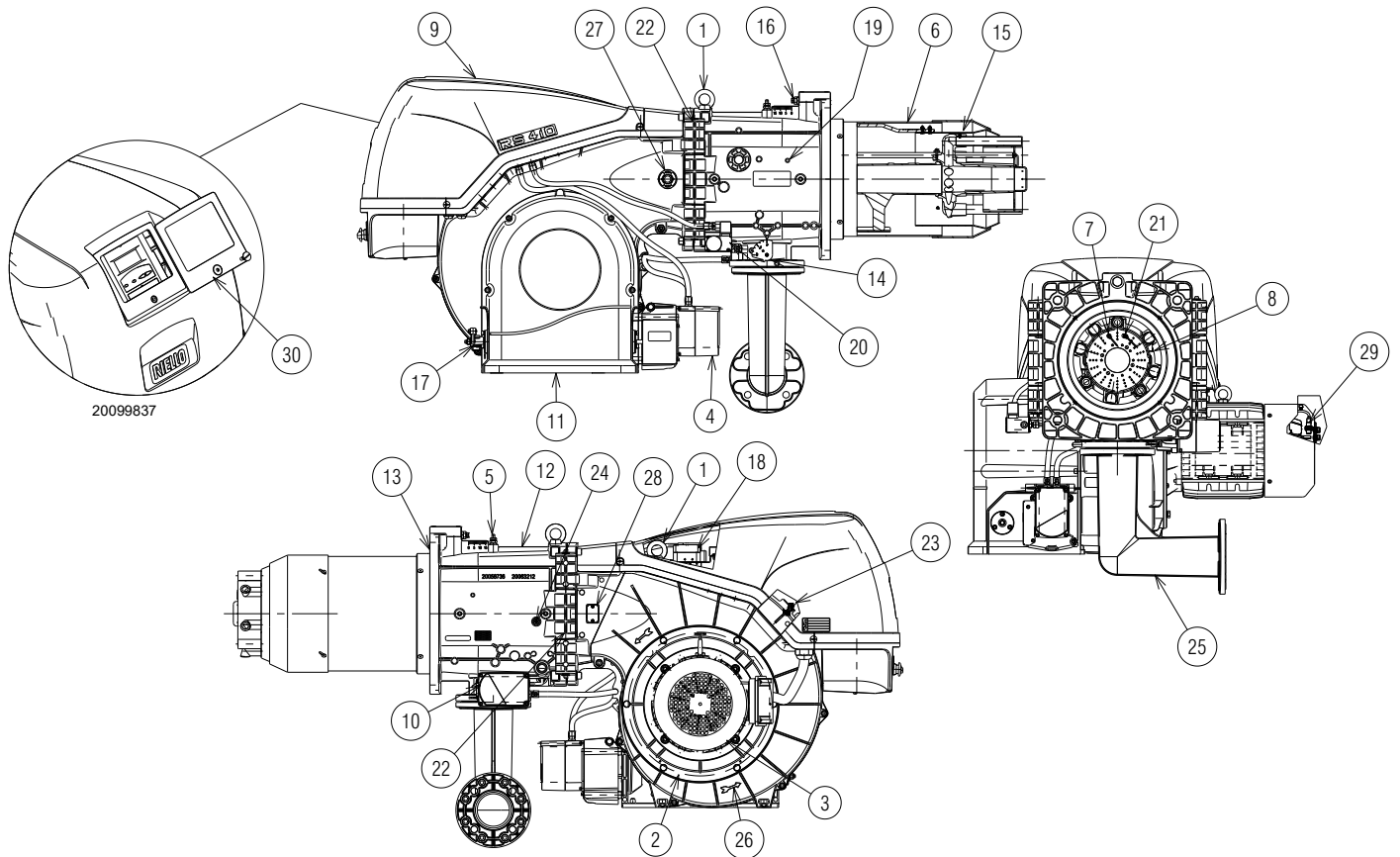

Fig. 4

- 1 Lifting rings
- 2 Fan
- 3 Fan motor
- 4 Air damper servomotor
- 5 Combustion head gas pressure test point
- 6 Combustion head
- 7 Ignition electrode
- 8 Flame stability disk
- 9 Electrical panel casing
- 10 Gas butterfly valve servomotor
- 11 Fan air inlet
- 12 Pipe coupling
- 13 Gasket for boiler fixing
- 14 Gas butterfly valve
- 15 Shutter
- 16 Combustion head movement screw
- 17 Lever for controlling the dampers with graduated scale
- 18 Air pressure switch
- 19 Combustion head air pressure test point
- 20 Maximum gas pressure switch with pressure test point
- 21 Flame sensor probe
- 22 Hinge for opening the burner
- 23 Pressure test point for air pressure switch "+"
- 24 Combustion head air pressure test points
- 25 Gas train adapter
- 26 Indication for checking the rotation direction of the purging motor
- 27 Flame inspection window
- 28 Adapt for flame sensor kit
- 29 Rpm sensor
- 30 Transparent protection



The burner can be opened to the right or to the left without links to the fuel supply side.



To open the burner see section "Access to head internal part" on page 21.

3.11 Electrical panel description

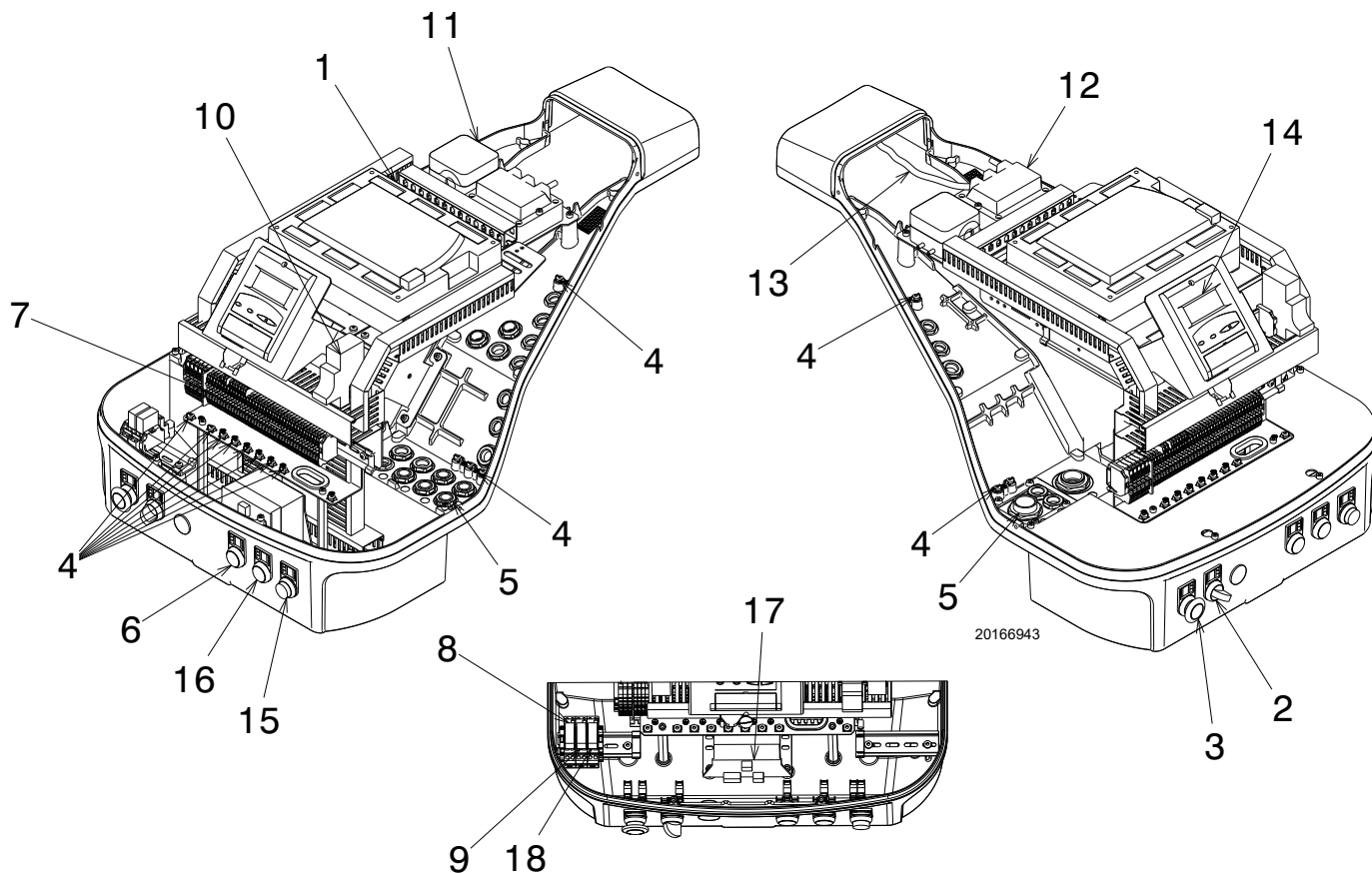

Fig. 5

- 1 Flame control
- 2 ON/OFF selector
- 3 Safety button
- 4 Earth terminal
- 5 Supply cables and external connections passage. See section "Electrical wiring" on page 27
- 6 Light signalling "POWER ON"
- 7 Main terminal supply board
- 8 Relay with clean contacts for signalling the burner is in lock-out
- 9 Relay with clean contacts for signalling the burner is operating
- 10 Auxiliary circuits fuse (includes a spare fuse)
- 11 Air pressure switch
- 12 Ignition transformer
- 13 Ionisation probe cable
- 14 Operator panel with LCD display
- 15 Light signalling burner lockout and reset button
- 16 Light signalling "OVERLOAD FAN MOTOR"
- 17 Flame control power supply
- 18 Relay with clean contacts

3.12 Flame control LMV52...)

Warnings



To avoid accidents, material or environmental damage, observe the following instructions!

The LMV52 flame control... is a safety device! Avoid opening or modifying it, or forcing its operation. Riello S.p.A. cannot assume any responsibility for damage resulting from unauthorised interventions!

Risk of explosion!

An incorrect configuration can provoke fuel overcharging, with the consequential risk of explosion! Operators must be aware that incorrect settings made on the AZL5... display and operating unit and incorrect settings of the fuel and / or air actuator positions can lead to dangerous burner operating conditions.

- All interventions (assembly and installation operations, assistance, etc.) must be carried out by qualified personnel.
- Before modifying the wiring in the LMV52 flame control connection area, fully disconnect the system from the power supply (omnipolar separation). Check the system is not powered and cannot be accidentally reconnected. Failure to do this will lead to the risk of electrocution.
- Protection against electrocution from the LMV5... flame control and all connected electric components is obtained with correct assembly.
- Before any intervention (assembly and installation operations, assistance, etc.), ensure the wiring is in order and that the parameters are correctly set, then make the safety checks.
- Falls and collisions can negatively affect the safety functions.
In this case, the flame control must not be operated, even if it displays no evident damage.
- In programming mode, the position check of actuators and VSD (checking electronic fuel / air ratio control) is different from the check during automatic operation. As for automatic operation, the actuators are guided together to the positions requested and, if an actuator does not reach the position requested, adjustments are made until the position is actually reached. However, in contrast to automatic operation, there are no time limits to these corrective actions.
The other actuators maintain their positions until all actuators have reached the positions currently required. This is absolutely important to set the fuel / air ratio control system.
During the time the fuel / air ratio curves are being programmed, the person making the plant settings must continuously monitor the quality of the combustion process (e.g. by means of a flue gas analyser). Also, if combustion levels are poor, or in the event of dangerous situations, the commissioning engineer must take appropriate action (e.g. switching off manually).

To ensure the safety and reliability of the LMV5... system, the following instructions must also be followed:

- avoid conditions that can favour the development of condensate and humidity. Otherwise, before switching on again, make sure that the entire flame control is perfectly dry!
- Static charges must be avoided since they can damage the flame control's electronic components when touched.



D9301

Fig. 6

Mechanical structure

The LMV5... flame control is a system to check the burners, based on a microprocessor and equipped with components to adjust and monitor medium and large capacity forced draught burners.

The base flame control of the LMV5... system incorporates the following components:

- Burner adjustment device with system for checking the seal of the gas valves
- Electronic fuel/air ratio monitoring device with a maximum of 6 (LMV52...) actuators
- Optional PID temperature / pressure controller (load controller)
- Optional VSD module Mechanical design.

Electrical connection of flame sensor

It is important for signal transmission to be almost totally free of any disturbances or loss:

- always separate the detector cables from the other cables:

– Line capacitance reduces the magnitude of the flame signal.
– Use a separate cable.

- Respect the allowed cable lengths.

Technical data

LMV52... base flame control	Mains voltage	AC 230V -15% / +10%
	Mains frequency	50 / 60 Hz ±6 %
	Power absorption	< 30W (normal)
	Safety class	I, with components in compliance with II and III, according to DIN EN 60730-1
Load on 'input' terminals	F1 unit fuse (internal)	6.3 AT
	Main fuse of perm. network (external)	Max. 16 AT
	Undervoltage	
	• Safety switch-off from operating position to mains voltage	< AC 186 V
	• Restart when mains voltage picks up	> AC 188 V
	Oil pump / magnetic clutch (nominal voltage)	
• Nominal current	2A	
• Power factor	cosφ > 0.4	
Air pressure switch test valve (nominal voltage)	• Nominal current	0.5A
	• Power factor	cosφ > 0.4
	Total load on the contacts:	
Load on 'output' terminals	• Mains voltage	AC 230 V -15 % / +10 %
	• Total unit input current (safety circuit) load on contacts due to:	Max. 5 A
	- Fan motor contactor	
	- Ignition transformer	
	- Valve	
	- Oil pump / magnetic clutch	
	Single contact loading:	
	Fan motor contactor (nominal voltage)	
	• Nominal current	1A
	• Power factor	cosφ > 0.4
	Alarm output (nominal voltage)	
	• Nominal current	1A
	• Power factor	cosφ > 0.4
Ignition transformer (nominal voltage)		
• Nominal current	2A	
• Power factor	cosφ > 0.2	
Fuel gas valve (nominal voltage)		
• Nominal current	2A	
• Power factor	cosφ > 0.4	
Fuel oil valve (nominal voltage)		
• Nominal current	1A	
• Power factor	cosφ > 0.4	
Cable lengths	Main line	Max. 100 m (100 pF/m)
Environmental conditions	Operation	DIN EN 60721-3-3
	Climatic conditions	Class 3K3
	Mechanical conditions	Class 3M3
	Temperature range	-20...+60°C
	Humidity	< 95% RH

Tab. G

3.13 Actuator

Warning notes



WARNING

To avoid injury to persons, damage to property or the environment, the following warning notes should be observed!

Do not open, interfere with or modify the actuators!

- All activities (mounting, installation and service work, etc.) must be performed by qualified staff.
- Before making any wiring changes in the connection area of the actuator, completely isolate the burner control from the mains supply (all-polar disconnection).
- Ensure protection against electric shock hazard by providing adequate protection for the connection terminals and by securing the housing cover.
- Check to ensure that wiring is in an orderly state.
- Fall or shock can adversely affect the safety functions. Such units must not be put into operation, even if they do not exhibit any damage.



WARNING

The housing cover may only be removed for short periods of time for wiring or when making the addressing.

It must be made certain that dust or dirt will not get inside the actuator while such work is carried out.

Use

The actuator (Fig. 7) is used to drive and position the air damper and the gas butterfly valve, without mechanical leverages but via the interposition of an elastic coupling.

When used in connection with burner controls or electronic fuel / air ratio control, the associated controlling elements are controlled depending on burner output.

Installation notes

- Always run the high-voltage ignition cables separate from the unit and other cables while observing the greatest possible distance.
- The holding torque is reduced when the actuator's power supply is switched off.



WARNING

When servicing or replacing the actuator, take care not to invert the connectors.

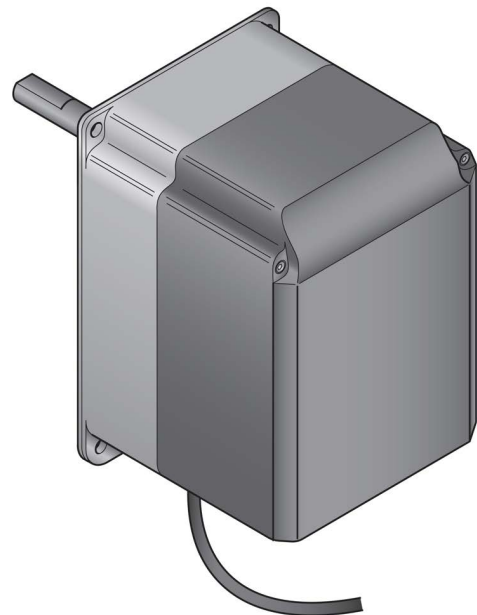

D8271

Fig. 7

Technical data

Model	SQM45.295A9
Operating voltage	AC 2 x 12 V via bus cable from the basic unit or via a separate transformer
Safety class	Extra low-voltage with safe isolation from mains voltage
Power consumption	9...15 VA
Degree of protection	To EN 60 529, IP 54, provided adequate cable entries are used
Electrical connections	RAST3.5 terminals
Direction of rotation (when facing the shaft)	- Standard: counterclockwise - Reverse: clockwise
Running time (min.) for 90°	10 s.
Holding torque (max.)	1.5 Nm
Nominal torque (max.)	3 Nm
Weight	approx. 1 kg
Environmental conditions:	
Operation	DIN EN 60721-3-1
Climatic conditions	class 1K3
Mechanical conditions	class 1M2
Temperature range	-20...+60 °C
Humidity	< 95 % r.h.

Tab. H



WARNING

Condensation, the formation of ice and the entry of water are prohibited!

3.14 PLL52... module (optional)

Warnings



To avoid accidents, material or environmental damage, observe the following instructions!

Avoid opening, modifying or forcing the device.

- All interventions (assembly and installation operations, assistance, etc.) must be carried out by qualified personnel.
- Falls and collisions can negatively affect the safety functions. In this case, the unit must not be operated, even if it displays no evident damage.

Assembly notes

- Check the relevant national safety standards are respected.

3.14.1 Terminal ratings, cable lengths and cross-sectional areas

Cable lengths / cross-sectional areas	
Electrical connection "X89"	Screw terminals up to max. 2.5 mm ²
Cable lengths	≤ 10 m fino a QGO20...
Cross-sectional areas	Refer to description of QGO20...
Analog inputs	
Air temperature detector	Pt1000 / LG-Ni1000
Flue gas temperature	Pt1000 / LG-Ni1000
QGO20...	Refer to data sheet N7842
Interface	Communication bus for LMV52...

Tab. I



Fig. 8

Technical data

Model	PLL52...
Mains voltage "X89-01"	AC 230 V -15%/10%
Safety class	I class with parts according to II class (DIN EN 60730-1)
Mains frequency	50 / 60 Hz ±6 %
Power consumption	Ca. 4 VA
Degree protection	IP54, housing closed
Transformer AGG5.220	
- Primary side	AC 230V
- Secondary side	AC 12 V (3x)
Environmental conditions:	
Storage	DIN EN 60721-3-1
Climatic conditions:	Class 1K3
Mechanical conditions:	Class 1M2
Temperature range:	-20...+60 °C
Humidity:	<95% r.h.
Transport	DIN EN 60721-3-2
Climatic conditions:	Class 2K2
Mechanical conditions:	Class 2M2
Temperature range:	-25...+70 °C
Humidity:	<95% r.h.
Operation	DIN EN 60 721-3-1
Climatic conditions:	Class 3K5
Mechanical conditions:	Class 3M2
Temperature range:	-20...+60 °C
Humidity:	< 95% r.h.

Tab. J

NOTE:

For detailed information, refer to the specific manual of PLL52 module.



Condensation, formation of ice and the entrance of water are not permitted!

3.15 Oxygen sensor QGO20 ... (optional)

Warnings



WARNING

To avoid accidents, material or environmental damage, observe the following instructions!

Avoid opening, modifying or forcing the oxygen sensor.

- All interventions (assembly and installation operations, assistance, etc.) must be carried out by qualified personnel.
- Before modifying the wiring in the sensor connection area, fully disconnect the burner control device from the power supply (omnipolar separation).
- Ensure that the sensor cannot be inadvertently switched on again and check this by making a voltage test.
- To avoid the risk of electrocution, protect the connection terminals in a suitable manner and correctly fix the cover.
- During operation, the flange of the sensor connection must be kept closed; all screws must be tightened securely.
- Check the wiring is in order.
- Falls and collisions can negatively affect the safety functions. In this case, the unit must not be operated, even if it displays no evident damage.
- Ensure that the device does not get into contact with explosive or inflammable gases.
- There is a risk of burning since the measuring cell works at an operating temperature of 700 °C and other accessible parts can get very hot too (> 60 °C).
- To prevent injury caused by the hot immersion tube, remove the device only after the equipment has cooled down.
- Make certain that the sensor's inlet and outlet are always kept free from dirt.
- Before cleaning the inlet and outlet, allow the sensor to cool down for at least 1 hour.
- Mount the sensor such that the connecting part (head to flange) is free so that the exchange of air is ensured. Otherwise, measurements might get distorted, possibly leading to dangerous situations.
- Ensure that there are no chemicals, such as solvent vapors, near the sensor.

Installation notes

- The flue gas flow passing the measuring cell must be homogeneous, with no or only little turbulence. When mounted too close to air dampers or pipe bends, faulty measurements can occur.
- A number of faults can distort the measurements (this can lead to dangerous situations in connection with oxygen trim control):
 - If the stack is not tight, false air can join the flue gases.
 - In that case, the residual oxygen content indicated by the sensor is higher than it actually is.
 - If the flue gas velocity is low, the sensor's response is slower, since the flue gases take more time to pass the measuring cell. In that case, it is recommended to mount the sensor in an inclined position (refer to the manual).
 - The greater the sensor's distance from the flame, the longer the dead time.

S9895

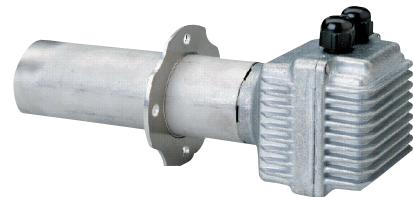

Fig. 9

NOTE:

For further explanations about the wiring connetions, please refer to the manual supplied with the accessory code 20045187.



WARNING

Condensation, formation of ice and the entrance of water are not permitted!

3.15.1 Technical data QGO20

Operating voltage of measuring cell's:	
– QGO20.000D27	AC 230 V ±15 %
– QGO20.000D17	AC 120 V ±15 % (only with LMV52 ... with PLL52...)
Mains frequency:	50...60 Hz ±6 %
Power consumption:	Max. 90 W, typical value 35 W (controlled)
Permissible mounting position:	Refer to mounting Instructions M7842
Degree of protection:	IP40, to be ensured through installation
Weight (net):	approx. 0.9 kg
Signal lines	
– Shielded 6-wires cable	Twisted pairs
– Shielding connected to terminal GND of the PL52...	
Wire diameter	LiFYCY3x2x0,2 o LYCY3x2x0,2
Measuring system	Zirconium dioxide measuring cell as an oxygen ion conductor
Permissible flue gas velocity (only with AGO20...)	1...10 m/s
Fuel type	Fuel oil EL or Natural gas H
Measuring range	0.2...20.9 % O ₂
Permissible cable length	Max. 100 m
Wire diameter	<10 m
Power supply lines (Net cable)	Min. 1 mm ²
– Cable diameter	QGO20.000D27: e.g. NYM 3 x 1,5
– Cable type	QGO20.000D17: UL AWM Style 1015/MTW or CSA-AWM/TEW
Required operating temperature of measuring cell	700 °C ±50 °C
Environmental conditions	
Storage	DIN EN 60721-3-1
Climatic conditions:	Class 1K3
Mechanical conditions:	Class 1M2
Temperature range:	-20...+60 °C
Humidity:	<95% r.h.
Transport	DIN EN 60721-3-2
Climatic conditions:	Class 2K2
Mechanical conditions:	Class 2M2
Temperature range:	-25...+70 °C
Humidity:	<95% r.h.
Operation	DIN EN 60721-3-3
Climatic conditions:	Class 3K5
Mechanical conditions:	Class 3M2
Temperature range:	
– Flange	Max. 250 °C
– Connecting head	Max. 70 °C
– Flue gases	≤300 °C
Humidity:	<95% r.h.
Installation altitude:	Max. 2000 m a.s.l.

Tab. K

4 Installation

4.1 Notes on safety for the installation

After carefully cleaning all around the area where the burner is to be installed, and arranging for the environment to be illuminated correctly, proceed with the installation operations.



All the installation, maintenance and disassembly operations must be carried out with the electricity supply disconnected.



The installation of the burner must be carried out by qualified personnel, as indicated in this manual and in compliance with the standards and regulations of the laws in force.



Combustion air inside the boiler must be free from hazardous mixes (e.g.: chloride, fluoride, halogen); if present, it is highly recommended to carry out cleaning and maintenance more frequently.

4.2 Handling

The burner packaging includes a wooden platform, it is therefore possible to move the burner (still packaged) with a transpallet truck or fork lift truck.



The handling operations for the burner can be highly dangerous if not carried out with the greatest attention: keep any unauthorised people at a distance; check the integrity and suitability of the available means of handling. Check also that the area in which you are working is empty and that there is an adequate escape area (i.e. a free, safe area to which you can quickly move if the burner should fall). When handling, keep the load at not more than 20-25cm from the ground.



After positioning the burner near the installation point, correctly dispose of all residual packaging, separating the various types of material.



Before proceeding with the installation operations, carefully clean all around the area where the burner will be installed.



Release the burner from the wooden platform by removing the bolts/nuts/screws that secure the burner to the platform. Handle the burner following the safety standards and regulations of the laws in force and using the eyebolts supplied as equipment.

4.3 Preliminary checks

Checking the consignment



After removing all the packaging, check the integrity of the contents. In the event of doubt, do not use the burner; contact the supplier.



The packaging elements (wooden cage or cardboard box, nails, clips, plastic bags, etc.) must not be abandoned as they are potential sources of danger and pollution; but should be collected and disposed of in the appropriate places.

Checking the characteristics of the burner

Check the identification label of the burner, showing:

- the model (A) (Fig. 10) and type of burner (B);
- the year of manufacture, in cryptographic form (C);
- the serial number (D);
- the data for electrical supply and the protection level (E);
- the absorbed electrical power (F);
- the types of gas used and the relative supply pressures (G);
- the data of the burner's minimum and maximum output possibilities (H) (see Firing rate).

Warning. The burner output must be within the boiler's firing rate;

- the category of the appliance/countries of destination (I).

20187902

		A		B	
		D	C	F	
		E		H	
GAS-KAASU	<input checked="" type="checkbox"/>	FAM.2		H	
GAZAEPHO	<input type="checkbox"/>	FAM.3		H	
I	I	I	I	I	I
CE					
					

Fig. 10



A burner label, or any other component, that has been tampered with, removed or is missing, prevents the definite identification of the burner and makes any installation or maintenance work difficult.

4.4 Operating position



- The burner is designed to operate only in positions 1, 2, 3 and 4 (Fig. 11).
- Installation 1 is preferable, as it is the only one that allows the maintenance operations as described in this manual.
- Installations 2, 3 and 4 permit operation but make maintenance and inspection of the combustion head more difficult.



- Any other position could compromise the correct operation of the appliance.
- Installation 5 is prohibited for safety reasons.

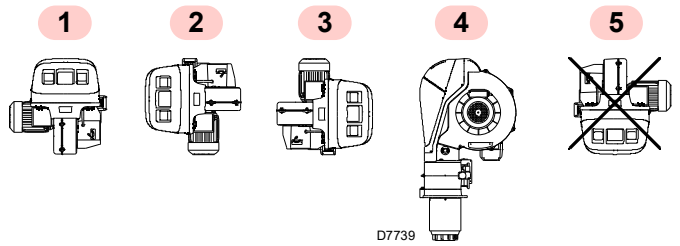

Fig. 11

4.5 Preparing the boiler

4.5.1 Boring the boiler plate

Drill the combustion chamber locking plate as shown in Fig. 12 (Tab. L). The position of the threaded holes can be marked using the thermal screen supplied with the burner.

4.5.2 Blast tube length

The length of the blast tube must be selected according to the indications provided by the manufacturer of the boiler, and in any case it must be greater than the thickness of the boiler door complete with its fettling.

For boilers with front flue passes 1)(Fig. 13) or flame inversion chamber, a protection in refractory material 5) must be inserted between the boiler fettling 2) and the blast tube 4).

The refractory can have a conical shape (minimum 60°).

This protective fettling must not compromise the extraction of the blast tube.

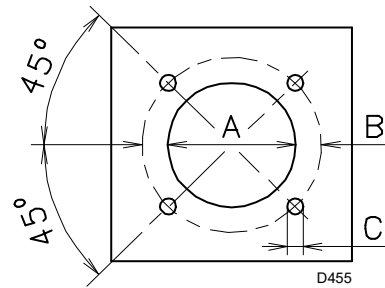

Fig. 12

mm	A	B	C
RS 310/EV O2 BLU	335	452	M18
RS 410/EV O2 BLU	335	452	M18
RS 510/EV O2 BLU	335	452	M18
RS 610/EV O2 BLU	350	452	M18

Tab. L

4.6 Securing the burner to the boiler



Prepare a suitable lifting system using the rings 3)(Fig. 13), after removing the fixing screws 7) of the casing 8).

- Fit the heat insulation supplied onto the blast tube 4)(Fig. 13).
- Fit the entire burner onto the boiler hole prepared previously (Fig. 12), and fasten with the screws supplied.



The seal between burner and boiler must be airtight.

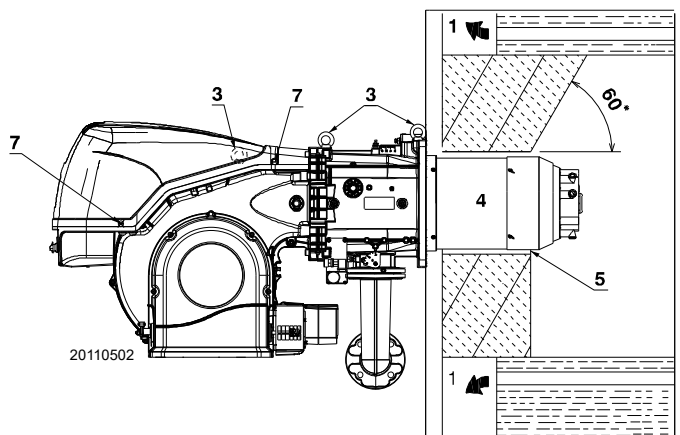

Fig. 13

4.7 Access to head internal part

The burner leaves the factory set for opening to the left, therefore maintaining the pin 1)(Fig. 14) in the housing.

To open the burner towards the left, proceed as follows:

- A** disconnect the plug/socket 9)(Fig. 14) of the maximum gas pressure switch;
- B** remove the screws 2);
- C** open the burner to a maximum of 100-150 mm by rotating around the hinge and release the cables of the probe 5) and electrode 11);
- D** fully open the burner as in Fig. 14;
- E** undo the screw 4) with pressure test point;
- F** release the head by lifting it from its housing 3), then take out the combustion head.



WARNING

To open the burner from the opposite side, before removing the pin 1)(Fig. 14), make sure that the 4 screws 2) are tight. Then shift the pin 1) to the opposite side, only then is it possible to remove the screws 2). Disconnect the socket 9 (Fig. 14) of the maximum gas pressure switch, then proceed as described above at point (C).

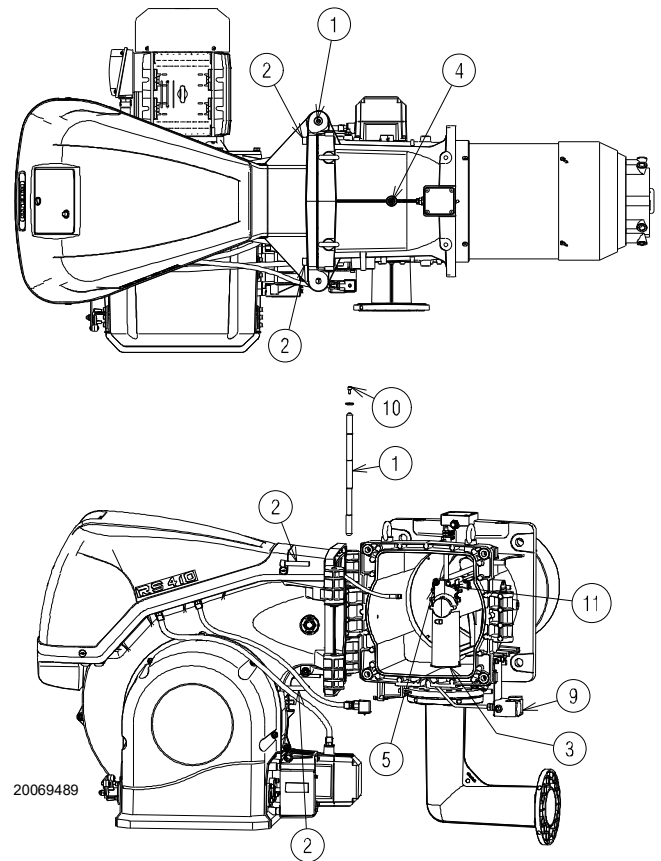

Fig. 14

4.8 Probe-electrode position



Check that the probe and the electrode are placed as in Fig. 15, according to the dimensions indicated.

RS 410-510-610/EV O2 BLU

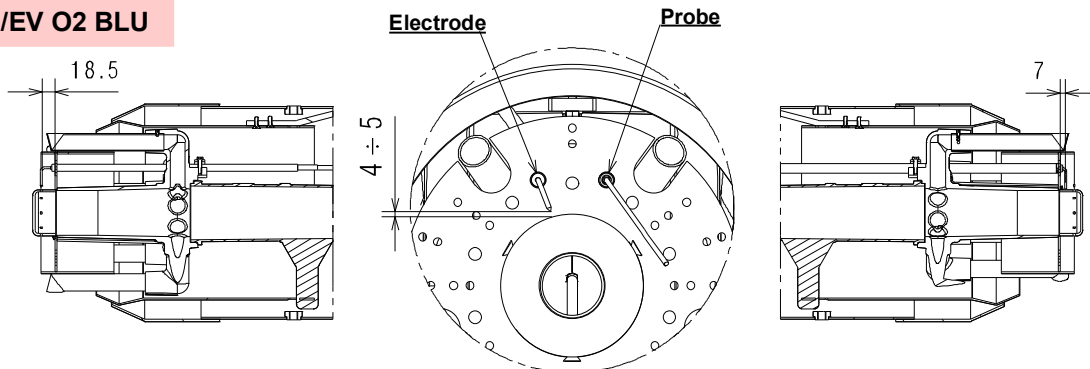

RS 310/EV O2 BLU

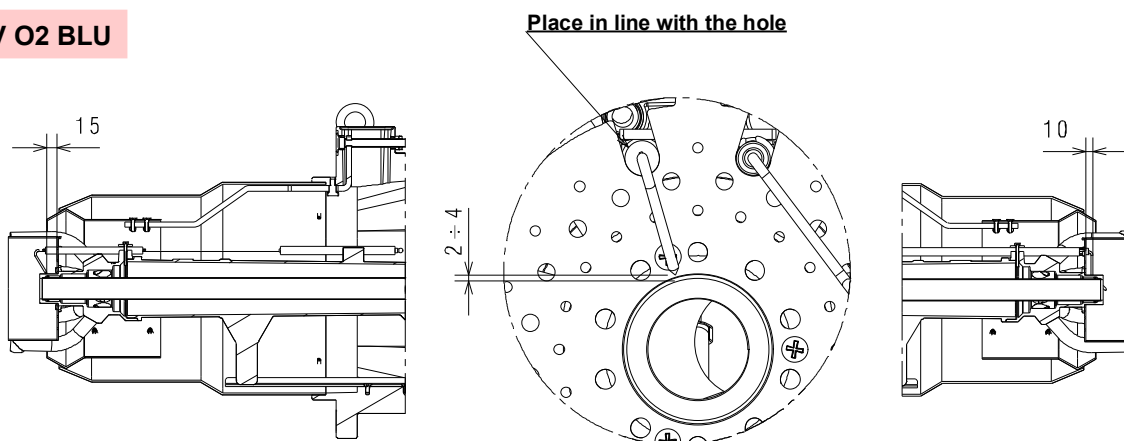

20071251

Fig. 15

4.9 Gas butterfly valve

If necessary, replace the gas butterfly valve. The correct position is shown in Fig. 16.

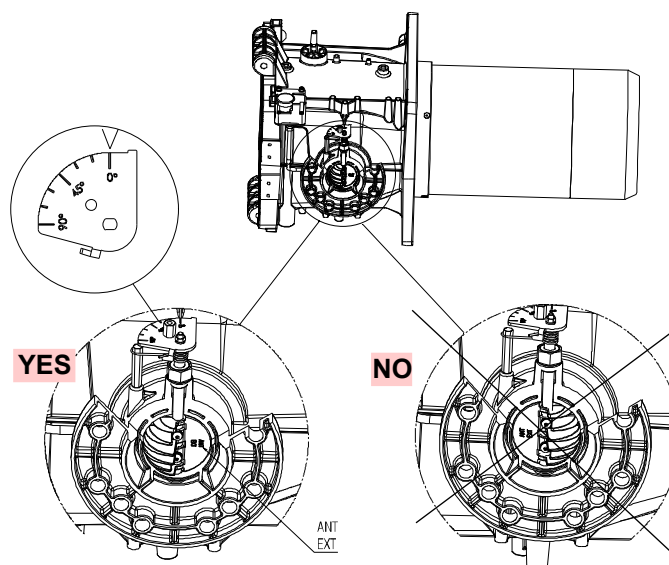

20078516

Fig. 16

4.10 Combustion head adjustment

Rotate the screw 1)(Fig. 18) until the notch you have found corresponds with the front surface of the screw itself.

The combustion head is opened by turning the screw 1) anti-clockwise.

The combustion head is closed by turning the screw 1) clockwise (Fig. 18).



The burner leaves the factory with the combustion head set at notch 0 (Fig. 17).

This setting allows to secure the movable components during the transport of the burner.

Before starting up the burner, carry out the settings according to the required output and indicated in the diagram (Fig. 17).

NOTE:

Depending on the specific application, the adjustment can be modified.

↓ No. Notches (air = gas)

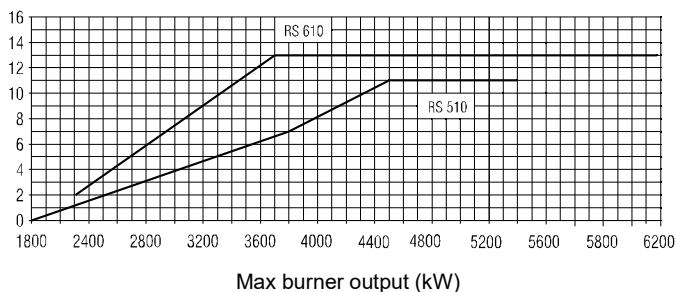
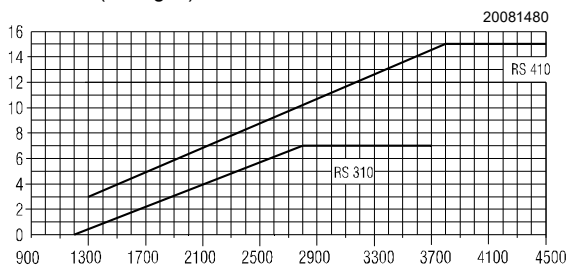
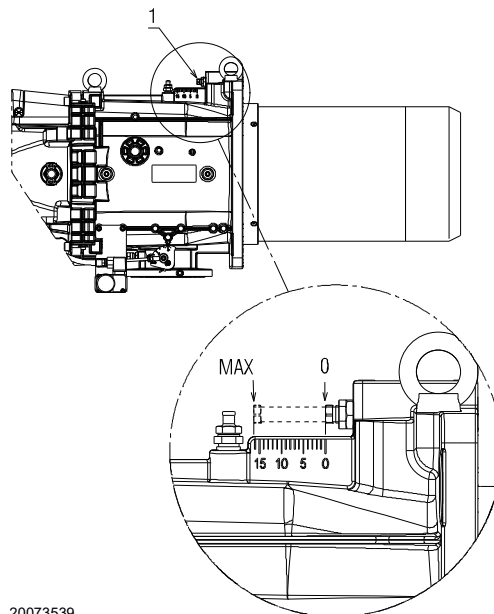

Fig. 17



20073539

Fig. 18

Only for the RS 310/EV O2 BLU model:

The RS 310 BLU burner is equipped with central air/gas adjustment. The factory setting is the following:

- AIR = notch 9**
- GAS = notch 0.**



Do not change these settings!

Only for specific cases, to change the central gas setting, do as follows:

- loosen the screws 1) and rotate the ring nut 3) until the notch you have found corresponds with the indicator 4)(Fig. 19).

To change the central air setting, do as follows:

- loosen the screws 1) and rotate the ring nut 2) until the notch you have found corresponds with the screw 1);
- Block the 2 screws 1)(Fig. 19).

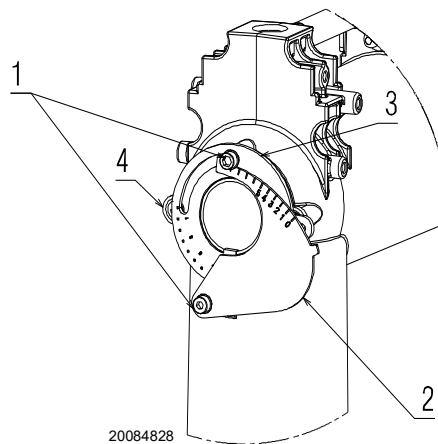

20084828

Fig. 19

4.11 Gas pressures



Explosion danger due to fuel leaks in the presence of a flammable source.

Precautions: avoid knocking, attrition, sparks and heat.

Make sure the fuel interception tap is closed before performing any operation on the burner.



The fuel supply line must be installed by qualified personnel, in compliance with current standards and laws.

4.11.1 Gas feeding line (Example) - Please refer to the gas train documentation for more information

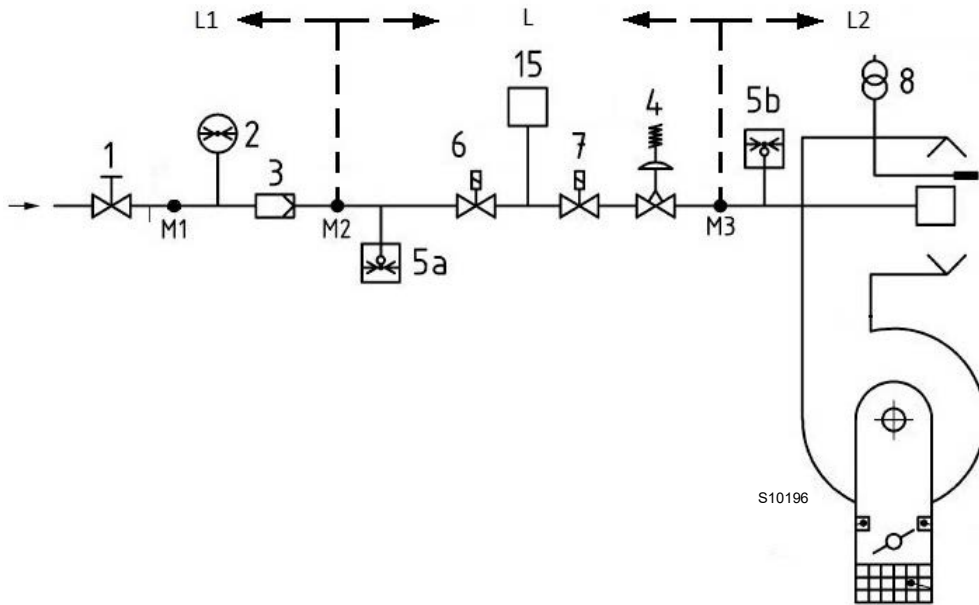

Fig. 20

Key (Fig. 20)

- 1 Manually operated shut-off valve
- 2 Pressure gauge
- 3 Filter
- 4 Governor
- 5a Low pressure protection device
- 5b Maximum gas pressure switch
- 6 1st safety shut-off device
- 7 2nd safety shut-off device
- 8 Ignition device
- 15 Valve leak detection control system
- L Gas train (supplied separately)
- L1 Responsibility of the installer
- L2 Burner
- M1 Pressure test point
- M2 Pressure test point
- M3 Pressure test point

4.11.2 Gas train

Approved according to standard EN 676 and provided separately from the burner.



Make sure that the gas train is properly installed by checking for any fuel leaks.

4.11.3 Gas train installation



Disconnect the electrical power using the main switch.



Check that there are no gas leaks.



Pay attention when handling the train: danger of crushing of limbs.



The operator must use the required equipment during installation.

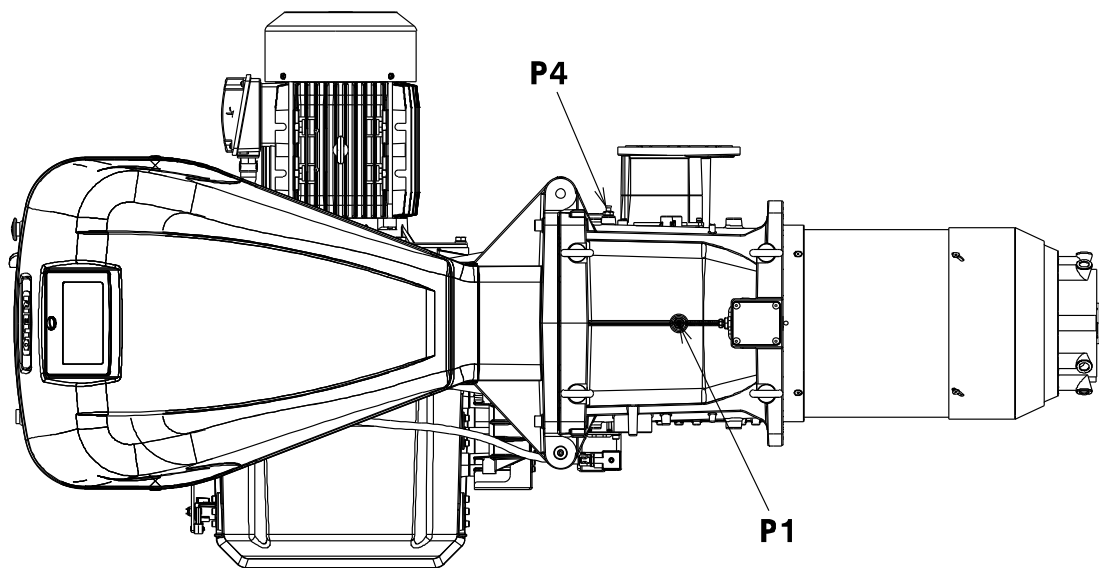

20110504

Fig. 21

4.11.4 Gas pressure

Tab. M indicates the minimum pressure drops along the gas supply line, depending on the maximum burner output.

The values shown in Tab. M refer to:

- Natural gas G 20 NCV 9.45 kWh/Sm³ (8.2 Mcal/Sm³)
- Natural gas G 25 NCV 8.13 kWh/Sm³ (7.0 Mcal/Sm³)

Column 1

Combustion head pressure drop.

Gas pressure measured at the test point P1)(Fig. 21), with:

- Combustion chamber at 0 mbar;
- Burner working at maximum output;
- Combustion head adjusted as in page 23.

Column 2

Pressure loss at gas butterfly valve 14)(Fig. 4 on page 11) with maximum opening: 90°.

Calculate the approximate maximum output of the burner in this way:

- subtract the combustion chamber pressure from the gas pressure measured at test point P1)(Fig. 21).
- Find, in the table Tab. M related to the burner concerned, the pressure value closest to the result of the subtraction.
- Read the corresponding output on the left.

Example RS 410/EV O₂ BLU with G20 natural gas:

Maximum output operation

Gas pressure at test point P1)(Fig. 21) = 58.1 mbar

Pressure in combustion chamber = 5 mbar

58.1 - 5 = 53.1 mbar

A pressure of 53.1 mbar, column 1, corresponds in the table Tab. M to an output of 4450 kW.

This value serves as a rough guide; the effective output must be measured at the gas meter.

To calculate the required gas pressure at test point P1)(Fig. 21), set the MAX output required from the burner operation:

- find the nearest output value in the table Tab. M for the burner in question.
- read, on the right (column 1), the pressure at the test point P1)(Fig. 21).
- Add this value to the estimated pressure in the combustion chamber.

Example for RS 410/EV O₂ BLU with G20 natural gas:

Required burner maximum output operation: 4450 kW

Gas pressure at an output of 4450 kW = 53.1 mbar

Pressure in combustion chamber = 5 mbar

53.1 + 5 = 58.1 mbar

Pressure required at test point P1)(Fig. 21).

	kW	1 Δp (mbar)		2 Δp (mbar)	
		G 20	G 25	G 20	G 25
RS 310/EV O ₂ BLU	1200	6.0	8.5	0.1	0.1
	1440	9.8	14.1	0.5	0.7
	1690	13.5	19.6	1.1	1.6
	1930	17.2	25.26	2.1	3.1
	2170	20.9	30.8	3.1	4.6
	2420	24.6	36.4	4.2	6.3
	2660	28.3	42	5.3	7.9
	2900	33.4	49.8	6.4	9.5
	3140	38	56.7	7.6	11.3
	3390	43.7	65.2	8.8	13.1
3630	50.1	74.7	10	14.9	
RS 410/EV O ₂ BLU	1500	2.6	3.9	0.3	0.5
	1800	7.1	10.6	1.5	2.2
	2090	11.5	17.2	2.8	4.2
	2380	16.1	24.0	4.0	6.0
	2680	21.1	31.5	5.4	8.1
	2980	26.1	38.9	6.8	10.1
	3270	31.2	46.6	8.2	12.2
	3560	36.3	54.2	9.6	14.3
	3860	41.9	62.5	11.2	16.7
	4160	47.5	70.9	12.7	18.9
4450	53.1	79.2	14.3	21.3	
RS 510/EV O ₂ BLU	1800	14.0	20.9	1.5	2.2
	2140	15.5	23.1	3.0	4.5
	2490	17.8	26.6	4.5	6.7
	2840	20.7	30.9	6.1	9.1
	3180	24.2	36.1	7.8	11.6
	3520	28.3	42.2	9.4	14.0
	3870	33.3	49.7	11.2	16.7
	4220	39.0	58.2	13.0	19.4
	4560	45.2	67.4	14.9	22.2
	4900	52.0	77.6	16.8	25.1
5250	59.7	89.1	18.8	28.0	
RS 610/EV O ₂ BLU	2200	9.3	13.9	3.3	4.9
	2600	13.6	20.3	5.0	7.5
	3010	18.6	27.8	7.0	10.4
	3420	24.1	36.0	8.9	13.3
	3820	30.1	44.9	11.0	16.4
	4220	36.5	54.5	13.0	19.4
	4630	43.7	65.2	15.3	22.8
	5040	51.5	76.8	17.6	26.3
	5440	59.6	88.9	19.9	29.7
	5840	68.2	101.8	22.3	33.3
6250	77.6	115.8	27.8	37.0	

Tab. M



The data of thermal output and combustion head gas pressure are related to full open (90°) gas butterfly valve.

4.12 Electrical wiring

Notes on safety for the electrical wiring



DANGER

- The electrical wiring must be carried out with the electrical supply disconnected.
- Electrical wiring must be made in accordance with the regulations currently in force in the country of destination and by qualified personnel. Refer to the wiring diagrams.
- The manufacturer declines all responsibility for modifications or connections different from those shown in the wiring diagrams.
- Check that the electrical supply of the burner corresponds to that shown on the identification label and in this manual.
- The burners equipped with LMV5... can operate in FS1 or FS2 mode (continuous/intermittent operation), see specific manual LMV5... . Refer to the following notes for the type of operation that has been set.
- The FS1 burners have been set for intermittent operation. This means that the burner should compulsorily be stopped at least once every 24 hours to enable the electric flame control to check its own safety and efficiency at start-up. Normally the boiler's thermostat/pressure switch ensures that the burner stops. If this is not the case, a time switch should be fitted in series to TL to stop the FS1 burner at least once every 24 hours. Refer to the wiring diagrams.
- The FS2 burners have been set for continuous operation. This means that the burner should compulsorily be stopped at least once every 72 hours to enable the electric flame control to check its own safety and efficiency at start-up. Normally, burner stopping is guaranteed by the boiler's thermostat/pressure switch. If this is not the case, a time switch should be fitted in series to TL to stop the FS2 burner at least once every 72 hours. Refer to the wiring diagrams.
- The electrical safety of the device is obtained only when it is correctly connected to an efficient earthing system, made according to current standards. It is necessary to check this fundamental safety requirement. In the event of doubt, have the electrical system checked by qualified personnel. Do not use the gas tubes as an earthing system for electrical devices.
- The electrical system must be suitable for the maximum power absorption of the device, as indicated on the label and in the manual, checking in particular that the section of the cables is suitable for that level of power absorption.
- For the main power supply of the device from the electricity mains:
 - do not use adapters, multiple sockets or extensions;
 - use a multiple pole switch with at least a 3 mm gap between the contacts (overvoltage category III), as envisaged by the present safety standards.
- Do not touch the device with wet or damp body parts and/or in bare feet.
- Do not pull the electric cables.
- Check the electric wiring inside the boiler complies with the national and local safety regulations.
- Live and neutral should not be mixed up (this could cause dangerous malfunctions, a loss of protection against electric shocks, etc.).
- Make sure the cable grommets of the connected cables comply with the relevant standards (e.g. EN60730 and EN60 335).
- When wiring the unit, make sure that AC 230V mains voltage cables are run strictly separate from extra low-voltage cables to avoid risks of electrical shock hazard.

Before carrying out any maintenance, cleaning or checking operations:



DANGER

Disconnect the electrical supply from the burner by means of the main system switch.



DANGER

Turn off the fuel interception tap.



DANGER

Avoid condensate, ice and water leaks from forming.

If the cover is still present, remove it and proceed with the electrical wiring according to the wiring diagrams.

Use flexible cables in compliance with the EN 60 335-1 standard.

4.12.1 Supply cables and external connections passage

All the cables to be connected to the burner must be threaded through cable grommets. The use of the cable grommets can take various forms; by way of example see Fig. 22.

Key (Fig. 22)

- 1 Electrical supply - Bore for M32
- 2 Consents and safety devices - Bore for M20
- 3 Minimum gas pressure switch - Bore for M20
- 4 VPS gas valve leak detection control kit- Bore for M20
- 5 Gas train - Bore for M20
- 6 Available - Bore for M20
- 7 Available - Bore for M16
- 8 Available - Bore for M32

Cable grommets used in the factory:

- A Rpm sensor
- B Maximum gas pressure switch
- C Servomotors

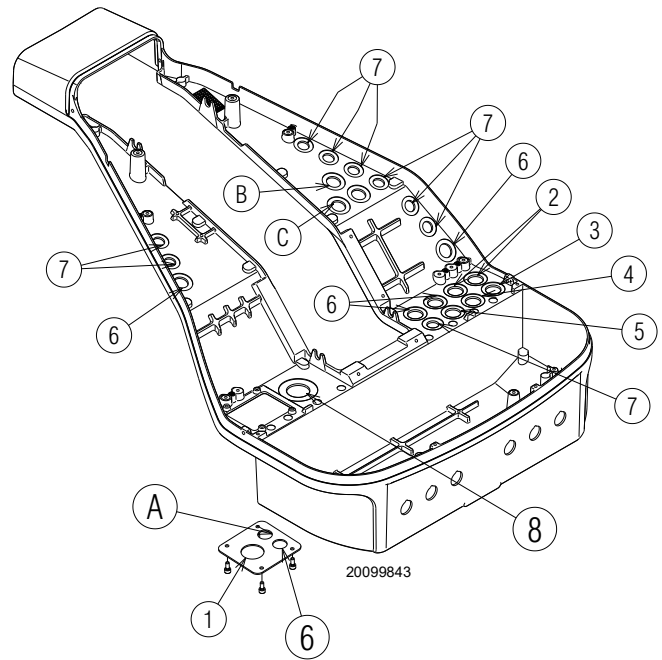

Fig. 22



After carrying out maintenance, cleaning or checking operations, reassemble the cover and all the safety and protection devices of the burner.

5 Start-up, calibration and operation of the burner

5.1 Notes on safety for the first start-up



WARNING

The first start-up of the burner must be carried out by qualified personnel, as indicated in this manual and in compliance with the standards and regulations of the laws in force.



WARNING

Check the correct working of the adjustment, command and safety devices.



WARNING

Refer to paragraph “Safety test - with gas ball valve closed” on page 36 before the first start-up.

5.2 Adjustments prior to ignition

Combustion head adjustment has already been already described in the section “Combustion head adjustment” on page 23.

In addition, the following adjustments must also be made:

- open manual valves upstream from the gas train;
- adjust the minimum gas pressure switch to the start of the scale;
- adjust the maximum gas pressure switch to the end of the scale;
- adjust the air pressure switch to the start of the scale;
- adjust the pressure switch for the leak detection control (PVP kit) (Fig. 33 on page 39) according to the instructions supplied with the kit;
- purge the air from the gas line. We recommend using a plastic tube routed outside the building and to purge air until gas is smelt.
- Fit a U-type pressure gauge or a differential pressure gauge (Fig. 23), with socket (+) on the gas pressure of the pipe coupling and (-) in the combustion chamber. The manometer readings are used to calculate MAX burner output using the Tab. M.
- Connect two lamps or testers to the two gas line solenoids to check the exact moment in which voltage is supplied. This operation is unnecessary if each of the two solenoids is equipped with a pilot light that signals voltage passing through.



CAUTION

Before starting up the burner, it is good practice to adjust the gas train so that ignition takes place in conditions of maximum safety, i.e. with gas delivery at the minimum.

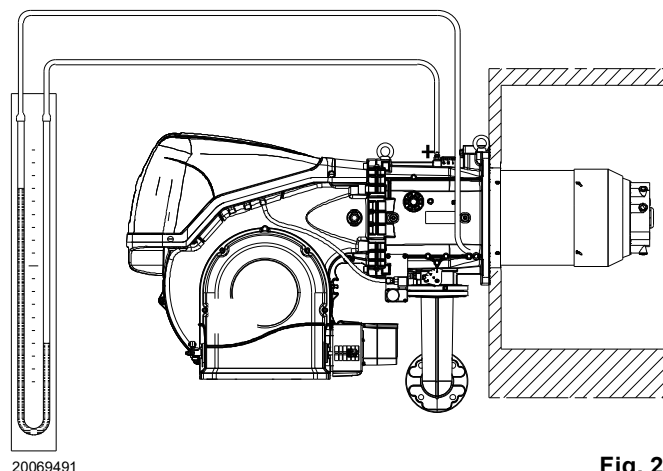

Fig. 23

5.3 Burner start-up

Feed electricity to the burner via the disconnecting switch on the boiler panel.

Close the thermostats/pressure switches. Turn the switch of Fig. 24 to position “**AUTO**”.



Make sure that the lamps or testers connected to the solenoids, or indicator lights on the solenoids themselves, show that no voltage is present. If voltage is present, stop the burner **immediately** and check the electrical wiring. When the burner starts, check the direction of the motor rotation, as indicated in Fig. 24.

As the burner is not fitted with a device to check the sequence of the phases, the motor rotation may be incorrect. As soon as the burner starts up, go in front of the cooling fan of the fan motor and check it is rotating anticlockwise.

If this is not the case:

- place the switch of Fig. 24 in position “**0**” and wait for the flame control to carry out the switch-off phase;
 - disconnect the electrical supply from the burner;
- invert the phases on the three-phase power supply.

Once the above steps are complete, the burner should light.

If the motor starts up, but the flame does not appear and the flame control goes into lockout, reset it and wait for a new ignition attempt.

If ignition is still not achieved, it may be that gas is not reaching the combustion head within the safety time period of 3 seconds. In this case increase gas ignition delivery.

The arrival of gas at the pipe coupling is indicated by the U-type pressure gauge (Fig. 23 on page 29).

If further burner lockouts occur, refer to the “Release procedure” given in the equipment manual supplied.



In the event of a burner lockout, more than two consecutive burner reset operations could cause damage to the installation. On the third lockout, contact the Aftersales Service.



If further lockouts or burner faults occur, interventions must only be made by qualified, authorised personnel (as indicated in this manual, and in compliance with the laws and regulations currently in force).

Once the burner has ignited, proceed with the global adjustment of the burner.

Further interfaces and communication functions with computers, for remote control or integration in central supervision systems are available on the basis of the configuration of the system.



The first start up and every further internal setting operation of the adjustment system or the expansion of the base functions require access by means of password and are to be carried out by service personnel who are especially trained for the internal programming of the instrument and the specific application created with this burner.

The first start-up and curve synchronisation manual is supplied with the burner.

At request, the complete manual for the control and setting of all parameters is available.

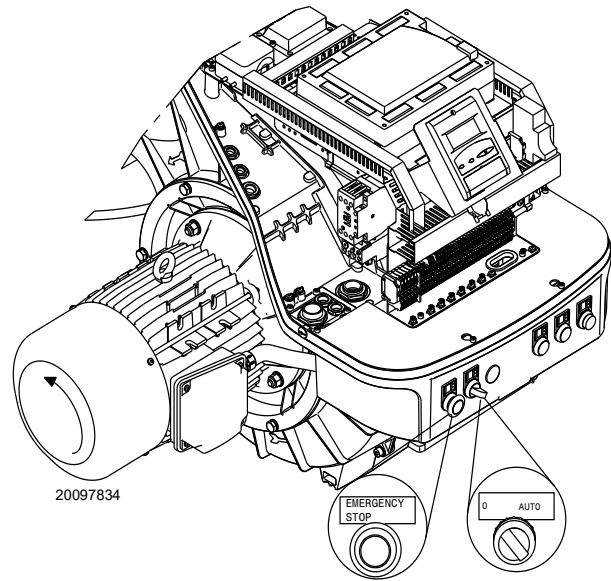

Fig. 24

5.4 Air / fuel adjustment

Air/fuel synchronisation is carried out with the relevant air and gas servomotors by logging a calibration curve by using the electronic cam.

It is advisable, to reduce the loss and for a wide calibration field, to adjust the servomotors to the maximum of the output used, the nearest possible to the maximum opening (90°).

The choking of the air, taking into account the maximum combustion output, takes place by varying the adjustment of the combustion head (see "Combustion head adjustment" on page 23).

On the gas butterfly valve, the fuel step according to the burner output required, with servomotor completely open, is carried out by the pressure stabiliser on the gas train.

5.4.1 Air adjustment for maximum output

- Adjust the servomotor to maximum opening (nearly 90°) so that the air butterfly valves are entirely open.

5.4.2 Air/fuel adjustment and output modulation system

The air/gas regulator and output modulation system equipping **RS/EV** series burners performs a number of integrated functions to optimise burner function, in both individual installations and in combination with other units (e.g. double furnace boiler or multiple heat generators in parallel).

The basic system functions control:

- 1 The dosage of the air and fuel through positioning using direct servocommands of the relevant valves eliminating the possible play in the calibration systems with mechanical cam lever mechanisms, used on traditional modulating burners.
- 2 The modulation of the burner output in accordance with the load required by the system, with maintenance of the pressure or temperature of the boiler at the operating values set.
- 3 The sequence (cascade adjustment) of more than one boiler through the suitable connection of the various units and the activation of the internal software of the individual systems (option).

Further interfaces and communication functions with computers, for remote control or integration in central supervision systems are available on the basis of the configuration of the system.



WARNING

The first start up and every further internal setting operation of the adjustment system or the expansion of the base functions require access by means of password and are to be carried out by service personnel who are especially trained for the internal programming of the instrument and the specific application created with this burner.

5.4.3 Burner adjustment

The optimum adjustment of the burner requires an analysis of flue gases at the boiler outlet.

Adjust in sequence:

- 1 - Output upon ignition
- 2 - MAX output
- 3 - MIN output
- 4 - Intermediate outputs between Min. and Max.
- 5 - Air pressure switch
- 6 - Maximum gas pressure switch
- 7 - Minimum gas pressure switch

5.4.4 Output upon ignition



WARNING

For safety purposes and correct product operation, the ignition output, if it is adjustable, must be carried out by authorized personnel and in compliance with the standards and regulations of the laws in force.

Air adjustment

The adjustment of the air is carried out by changing the angle of the air damper changing the degrees of the air servomotor inside the electronic cam programme.

5.4.5 Maximum output

The MAX output must be set within the firing rate (Fig. 2 on page 9).

Adjustment of gas delivery

Measure the gas delivery on the gas meter.

As an indicative guide it can be taken from Tab. M on page 26, just read the gas pressure on the pressure gauge (shown in Fig. 23 on page 29) and follow the instructions given on page 26.

- If it is necessary to reduce it, lower the output gas pressure via the pressure adjuster located beneath the gas valve.
- If delivery needs to be increased, increase the adjuster outlet gas pressure.

Air adjustment

If necessary vary the degrees of the air servomotor.

5.4.6 Minimum output

The MIN output must be set within the firing rate (Fig. 2 on page 9).

5.5 Final adjustment of the pressure switches

5.5.1 Air pressure switch

Adjust the air pressure switch (Fig. 25) after performing all other burner adjustments with the air pressure switch set to the start of the scale.

With the burner operating at minimum output, insert a combustion analyser in the stack, slowly close the suction inlet of the fan (for example, with a piece of cardboard) until the CO value does not exceed 100 ppm.

Slowly turn the appropriate knob clockwise until the burner goes into lockout.

Check the indication of the arrow pointing upwards on the graduated scale. Turn the knob clockwise again, until the value shown on the scale corresponds with the arrow pointing downwards, and so recovering the hysteresis of the pressure switch shown by the white mark on a blue background, between the two arrows.

Now check the correct start-up of the burner. If the burner locks out again, turn the knob anti-clockwise a little bit more. During these operations it may be useful to measure the air pressure with a pressure gauge.

The connection of the pressure gauge is shown in Fig. 25. The standard configuration is that with the air pressure switch connected in absolute mode. Note the presence of a "T" connection, not supplied.

In certain applications in strong depression situations, the connection of the pressure switch does not allow it to change over. In this case it is necessary to connect the pressure switch in differential mode, applying a second tube between the air pressure switch and the fan suction line mouth.

In this case also, the pressure gauge must be connected in differential mode, as shown in Fig. 25.



Connecting the air pressure switch in differential mode, the burner will no longer be certified according to the EN 676 standard.



Connection of the pressure gauge with the pressure switch in absolute mode

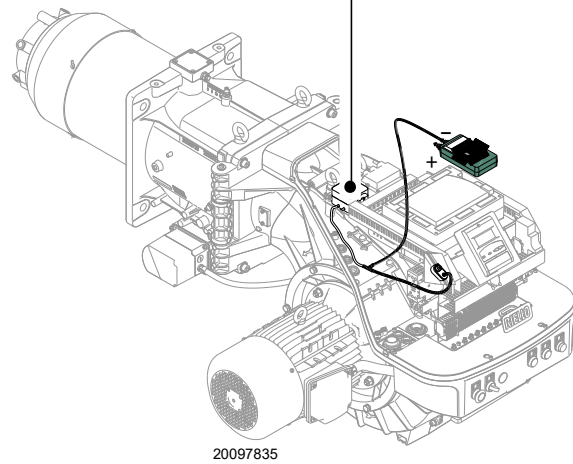

Fig. 25

5.6 Pressure switch adjustment

5.6.1 Maximum gas pressure switch

Adjust the maximum gas pressure switch (Fig. 26) after making all other burner adjustments with the maximum gas pressure switch set to the end of the scale.

To calibrate the maximum gas pressure switch, open the tap and then connect a pressure gauge to its pressure test point.

The maximum gas pressure switch must be regulated to a value no higher than 30% of the measurement read on the gauge when the burner is working at maximum output.

After making the adjustment, remove the pressure gauge and close the tap.

5.6.2 Minimum gas pressure switch

The purpose of the minimum gas pressure switch is to prevent the burner from operating in an unsuitable way due to too low gas pressure.

Adjust the minimum gas pressure switch (Fig. 27) after having adjusted the burner, the gas valves and the gas train stabiliser. With the burner operating at maximum output:

- install a pressure gauge downstream of the gas train stabiliser (for example at the gas pressure test point on the burner combustion head);
- choke slowly the manual gas cock until the pressure gauge detects a decrease in the pressure read of about 0.1 kPa (1 mbar). In this phase, verify the CO value which must always be less than 100 mg/kWh (93 ppm).
- Increase the adjustment of the gas pressure switch until it intervenes, causing the burner shut-down;
- remove the pressure gauge and close the cock of the gas pressure test point used for the measurement;
- open completely the manual gas cock.



WARNING

1 kPa = 10 mbar

5.6.3 PVP pressure switch kit

Adjust the pressure switch for the leak detection control (PVP kit) (Fig. 28) according to the instructions supplied with the kit.

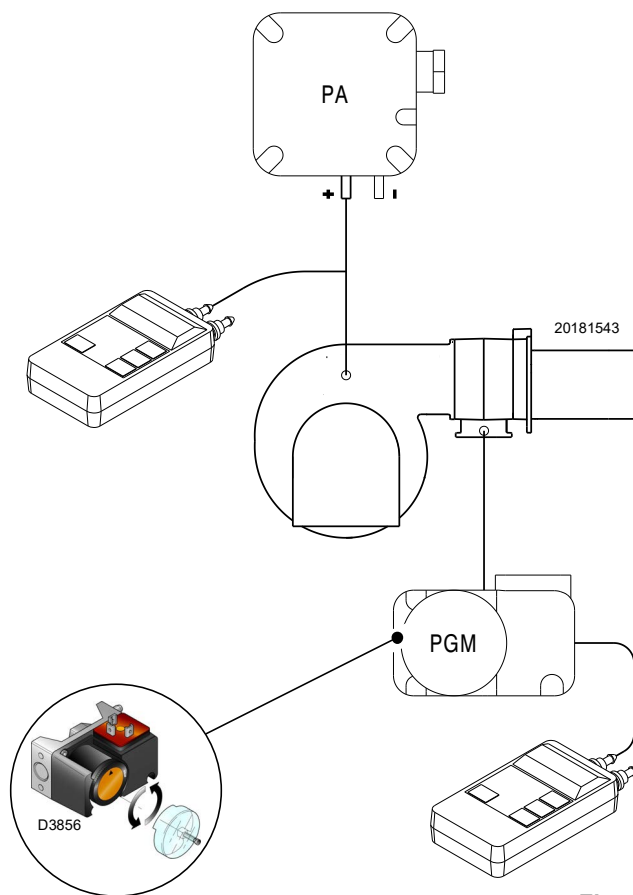

Fig. 26

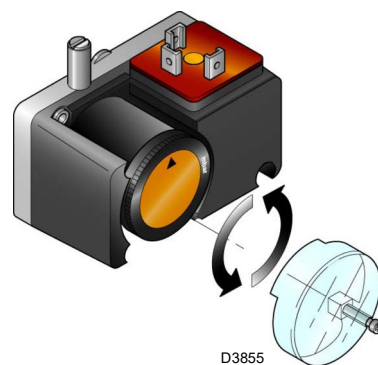

Fig. 27

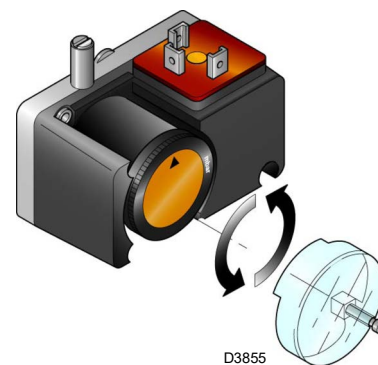

Fig. 28

5.7 Operation

Once the start-up cycle is completed, the servomotor command moves on to the thermostat/pressure switch TR that controls the pressure or the temperature in the boiler.

- If the temperature or the pressure is low, the burner progressively increases the output as far as the MAX value.
- If the temperature or the pressure increases, the burner progressively reduces the output as far as the MIN value. The sequence repeats endlessly.

- The burner stops when the heat request is less than the heat supplied by the burner at MIN output.
- The thermostat/pressure switch TL opens, the flame control carries out the switching off phase.
- The air damper closes completely to reduce heat losses to a minimum.

5.8 Ignition failure

If the burner does not switch on, there is a lockout within 3s of the electrical supply reaching the gas valve.

It may be that the gas does not arrive at the combustion head within the safety time of 3s.

In this case increase gas ignition flow rate. The arrival of gas to the pipe coupling is displayed on the pressure gauge, as shown in Fig. 31 on page 37.



In the event the burner stops, in order to prevent any damage to the installation, do not unblock the burner more than twice in a row.

If the burner locks out for a third time, contact the customer service.



In the event there are further lockouts or faults with the burner, the maintenance interventions must only be carried out by qualified, authorised personnel, in accordance with the contents of this manual and in compliance with the standards and regulations of current laws.

5.9 Burner flame goes out during operation

If the flame should go out during operation, the burner will lockout within 1s.

5.10 Stopping of the burner

The burner can be stopped by:

- intervening on the disconnecting switch of the electrical supply line, located on the boiler panel;
- using the switch "0-AUTO" of Fig. 24 on page 30.

5.11 Final checks (with burner operating)

<ul style="list-style-type: none"> ➤ Open the thermostat/pressure switch TL ➤ Open the thermostat/pressure switch TS 		The burner must stop
<ul style="list-style-type: none"> ➤ Turn the gas maximum pressure switch knob to the minimum end of scale position ➤ Turn the air pressure switch knob to the maximum end of scale position 		The burner must stop in lockout
<ul style="list-style-type: none"> ➤ Turn off the burner and cut off the power ➤ Disconnect the minimum gas pressure switch connector 		The burner must not start
<ul style="list-style-type: none"> ➤ Disconnect the connector of the ionisation probe 		The burner must stop in lockout due to ignition failure

Tab. N



Make sure that the mechanical locking systems on the various adjustment devices are fully tightened.

5.12 Description of O₂ trim control (optional)

A special feature of the LMV52... is control of the residual O₂ content to increase the boiler's efficiency. The LMV52... uses a QGO20..., an external PLL52..., and the standard components of the LMV51... The PLL52... is a detached measuring module for the O₂ sensor and for 2 temperature sensors (Pt1000 / LG-Ni1000). The module communicates with the LMV52... via CAN bus.

The following generic diagram shows the system (Fig. 29).

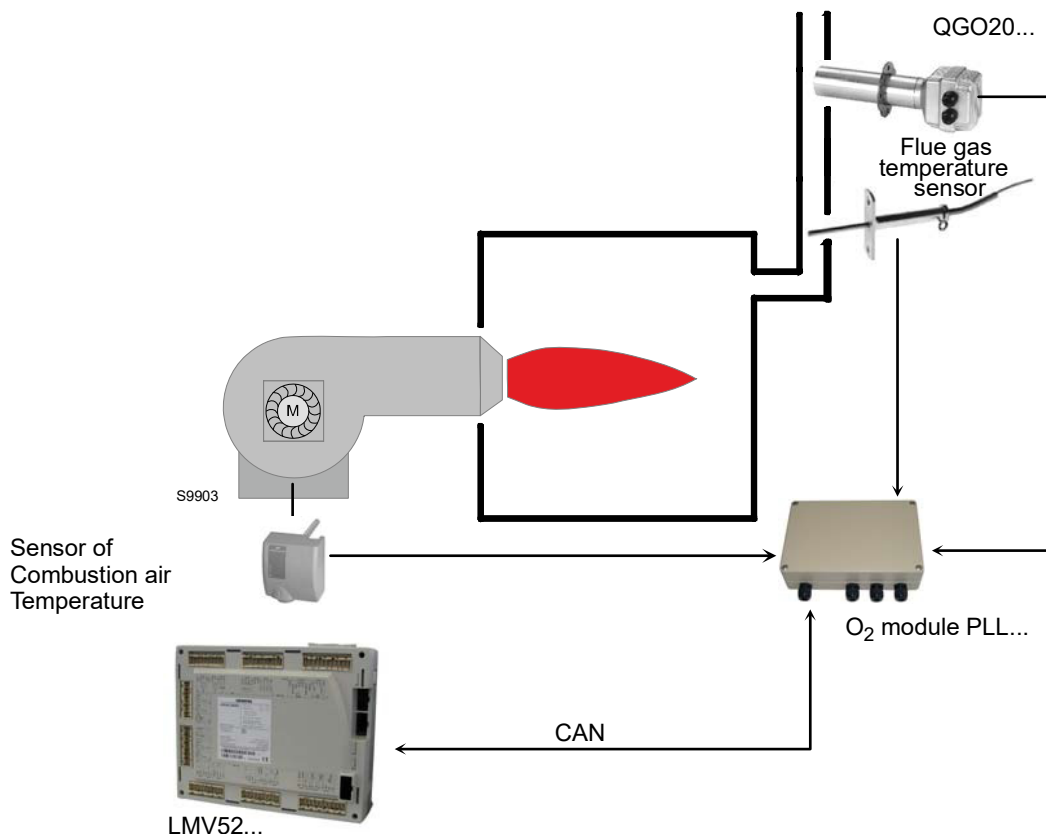

Fig. 29

5.12.1 Operating principle of O₂ trim control

The residual O₂ control system reduces the amount of combustion air depending on the control deviation (O₂ setpoint minus actual of O₂). The amount of combustion air is normally influenced by several actuators and, if used, by a VSD. **Reduction of the amount of air is reached by reducing the «air rate» of the air-regulating actuators.**

For that purpose, the damper positions of these actuators are calculated from some other load point on the ratio control curves. Hence, due to the parameterized ratio control curves, the air-regulating actuators are in a fixed relation to one another.

O₂ trim control is supported by **precontrol**. **It calculates the air rate reduction such that changes in burner load do not require the O₂ trim controller to interfere.** Consideration is given to a number of measured values that are ascertained when the burner is set. This means that the controller only becomes active when environmental conditions (temperature, pressure) change, and not when the burner load changes.



The installation and setting of the system must be carried out by qualified personnel, as indicated in the specific documentation of the device.

6 Maintenance

6.1 Notes on safety for the maintenance

The periodic maintenance is essential for the good operation, safety, yield and duration of the burner.

It allows you to reduce consumption and polluting emissions and to keep the product in a reliable state over time.



The maintenance interventions and the calibration of the burner must only be carried out by qualified, authorised personnel, in accordance with the contents of this manual and in compliance with the standards and regulations of current laws.

Before carrying out any maintenance, cleaning or checking operations:



Disconnect the electrical supply from the burner by means of the main system switch.



Turn off the fuel interception tap.



Wait for the components in contact with heat sources to cool down completely.

6.2 Maintenance programme

6.2.1 Maintenance frequency



The gas combustion system should be checked at least once a year by a representative of the manufacturer or another specialised technician.

6.2.2 Safety test - with gas ball valve closed

It is fundamental to ensure the correct execution of the electrical connections between the gas solenoid valves and the burner to perform safely the commissioning.

For this purpose, after checking that the connections have been carried out in accordance with the burner's electrical diagrams, an ignition cycle with closed gas ball valve -dry test- must be performed.

- 1 The manual ball gas valve must be closed
- 2 The electrical contacts of the burner limit switch need to be closed
- 3 Ensures closed the contact of the low gas pressure switch
- 4 Make a trial for burner ignition

The start-up cycle must be as follows:

- Starting the fan for pre-ventilation
- Performing the gas valve seal control, if provided
- Completion of pre-ventilation
- Arrival of the ignition point
- Power supply of the ignition transformer
- Electrical Supply of solenoid gas valves

Since the manual gas ball valve is closed, the burner will not light up and its flame control will go to a safety lockout condition.

The actual electrical supply of the solenoid gas valves can be verified by inserting a tester. Some valves are equipped with light signals (or close/open position indicator) that turn on at the same time as their power supply.



IF THE ELECTRICAL SUPPLY OF THE GAS VALVES OCCURS AT UNEXPECTED TIMES, DO NOT OPEN MANUAL GAS BALL VALVE, SWITCH OFF POWER LINE; CHECK THE WIRES; CORRECT THE ERRORS AND REPEAT THE COMPLETE TEST.

6.2.3 Checking and cleaning



The operator must use the required equipment during maintenance.

Combustion head

Open the burner and make sure that all components of the combustion head are in good condition, not deformed by the high temperatures, free of impurities from the surroundings and correctly positioned.

Burner

Check that there are not excess wear or loosen screws.
Clean the outside of the burner.

Fan

Check to make sure that no dust has accumulated inside the fan or on its blades, as this condition will cause a reduction in the air flow rate and provoke polluting combustion.

Boiler

Clean the boiler as indicated in its accompanying instructions in order to maintain all the original combustion characteristics intact, especially the flue gas temperature and combustion chamber pressure.

Gas leaks

Make sure that there are no gas leaks on the pipe between the gas meter and the burner.

Gas filter

Change the gas filter when it is dirty.

Combustion

The optimum calibration of the burner requires an analysis of the flue gases.

Significant differences with respect to the previous measurements indicate the points where most care should be exercised during maintenance. If the combustion values measured before starting maintenance do not comply with applicable legislation or do not indicate efficient combustion, consult the Tab. O or contact our Technical Support Service to implement the necessary adjustments.

It is advisable to set the burner according to the type of gas used and following the indications in Tab. O.

EN 676		Air excess			
		Max. output. $\lambda \leq 1,2$		Min. output. $\lambda \leq 1,3$	
GAS	CO ₂ theoretic al max. 0% O ₂	CO ₂ % Calibration		CO	NO _x
		$\lambda = 1.2$	$\lambda = 1.3$	mg/kWh	mg/kWh
G 20	11.7	9.7	9.0	≤ 100	≤ 170
G 25	11.5	9.5	8.8	≤ 100	≤ 170
G 30	14.0	11.6	10.7	≤ 100	≤ 230
G 31	13.7	11.4	10.5	≤ 100	≤ 230

Tab. O

6.2.4 Safety components

The safety components should be replaced at the end of their life cycle indicated in the Tab. P.

The specified life cycles do not refer to the warranty terms indicated in the delivery or payment conditions.

Safety component	Life cycle
Flame control	10 years or 250,000 operation cycles
Flame sensor	10 years or 250,000 operation cycles
Gas valves (solenoid)	10 years or 250,000 operation cycles
Pressure switches	10 years or 250,000 operation cycles
Pressure adjuster	15 years
Servomotor (electronic cam (if present))	10 years or 250,000 operation cycles
Oil valve (solenoid) (if present)	10 years or 250,000 operation cycles
Oil regulator (if present)	10 years or 250,000 operation cycles
Oil pipes/couplings (metallic) (if present)	10 years
Fan impeller	10 years or 500,000 start-ups

Tab. P

6.2.5 Measuring the ionisation current

The burner is fitted with an ionisation system to check that a flame is present.

The minimum current for flame control operation is 6 µA.

The burner provides a much higher current, so controls are not normally required.

However, if it is necessary to measure the ionisation current, disconnect the plug-socket on the ionisation probe cable and insert a direct current microammeter with a base scale of 100 µA, as shown in Fig. 30.



Carefully check the polarities!

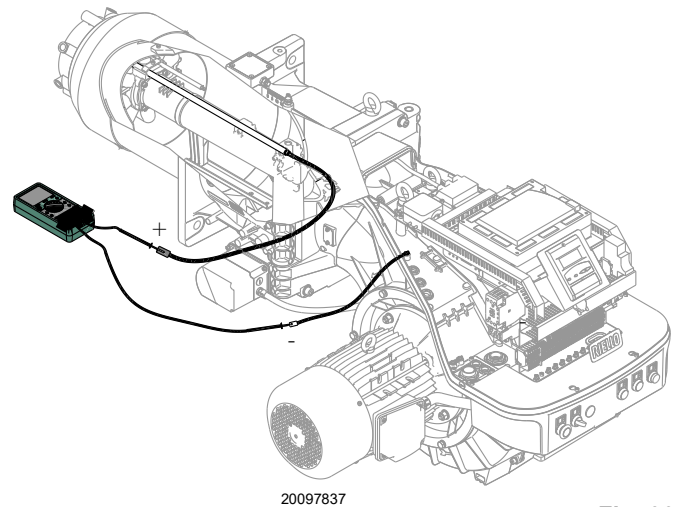

Fig. 30

6.2.6 Checking the air and gas pressure on the combustion head

To carry out this operation it is necessary to use a pressure gauge to measure the air and gas pressure at the combustion head, as shown in Fig. 31.

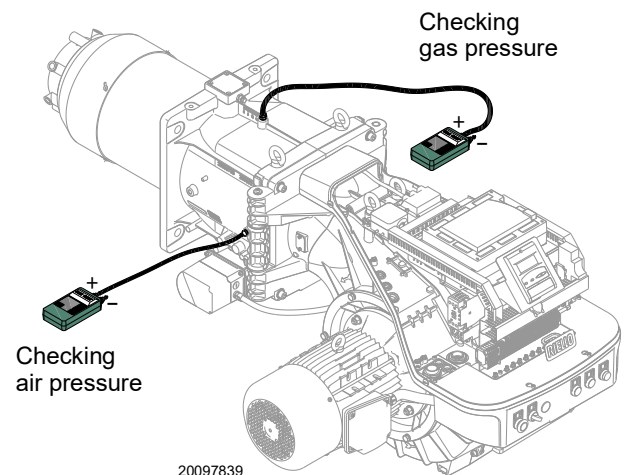

Fig. 31

6.3 Checking the position of the rpm sensor

To calibrate the rpm sensor 6)(Fig. 32), proceed as follows:

- remove the cover 1) unscrewing the screws 2);
- unscrew or screw the nuts 3) - 5) and the rpm detection disc 4) so that its distance from the rpm sensor 6) is about 2 mm.;
- place the plate 4) on the nut 5) and fix with the lock nut 3);
- close the cover 1) by screwing the screws 2).

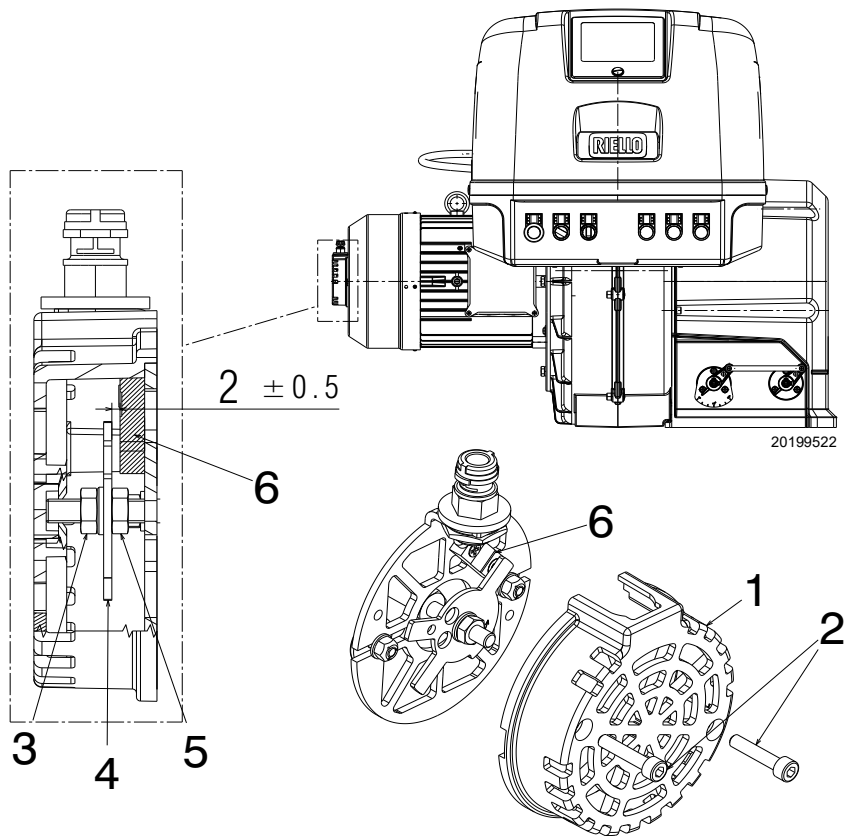

Fig. 32

Key (Fig. 32)

- 1 Cover
- 2 Screws for cover fixing
- 3 Lock nut
- 4 Rpm detection disc
- 5 Lower nut
- 6 Rpm sensor

6.4 Opening the burner



Disconnect the electrical supply from the burner by means of the main system switch.



Turn off the fuel interception tap.



Wait for the components in contact with heat sources to cool down completely.

To open the burner, use the same procedure set out in “Access to head internal part” on page 21.

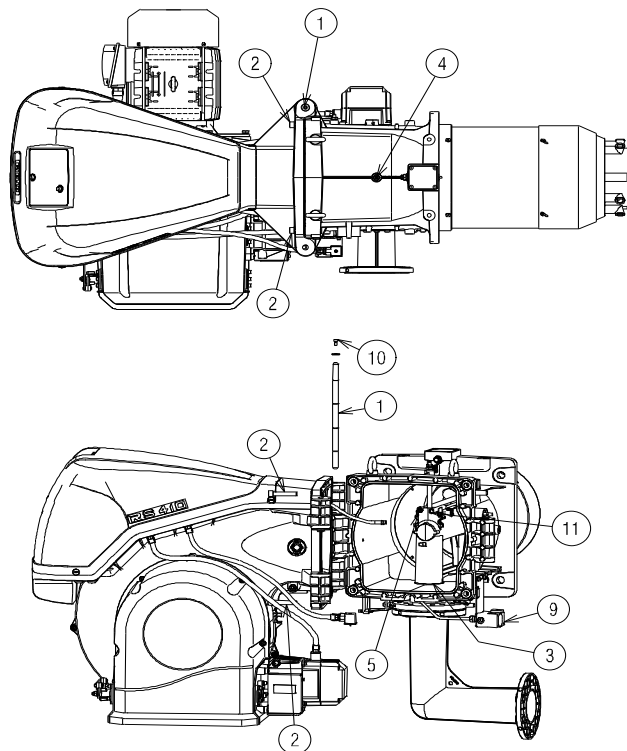

20069489

Fig. 33

6.5 Closing the burner

Refit following the steps described but in reverse order; refit all burner components as they were originally assembled.



After carrying out maintenance, cleaning or checking operations, reassemble the cover and all the safety and protection devices of the burner.

A Appendix - Accessories

Inverter kit (VSD)

Burner	Line voltage	Motor Output (kW)	Inverter Output (kW)	Code
RS 310/EV O2 BLU	400V	7.5	7.5	20163074
RS 410/EV O2 BLU	400V	9.2	11	20163093
RS 510/EV O2 BLU	400V	12	15	20163096
RS 610/EV O2 BLU	400V	15	15	20163096



WARNING

The use of inverters other than those indicated by the manufacturer may lead to burner failure and, in extreme cases, a potential risk of harm to people and damage to property.

The manufacturing company shall not be liable for any such damage arising from non-observance of the requirements contained in this manual.

Flame sensor kit

Code

On demand

Soundproofing box kit

Burner	Type	dB(A)	Code
All models	C7	10	3010376

Continuous purging kit

Burner	Code
All models	20077810

Software interface kit (ACS450)

Burner	Code
All models	3010436

Efficiency kit with oxygen control kit

Burner	Code
All models	3010377

Oxygen control kit

Burner	Code
All models	20045187

PVP kit (Seal control function - See gas train booklet)

Burner	Ramp type	Code
All models	MB - CB	3010344

Gas trains in compliance with EN 676

Please refer to manual.



The installer is responsible for the addition of any safety device not foreseen in this manual.

B Appendix - Electrical panel layout

1	Index of layouts
2	Indication of references
3	Single-wire output layout
4	Functional layout
5	Functional layout LMV 52...
6	Functional layout LMV 52...
7	Functional layout LMV 52...
8	Functional layout LMV 52...
9	Functional layout LMV 52...
10	Functional layout LMV 52... with Kit O ₂
11	Functional layout LMV 52...
12	Functional layout PLL 52.../QGO 20... with Kit O ₂
13	Electrical wiring that the installer is responsible for
14	Electrical wiring that the installer is responsible for

2 Indication of references

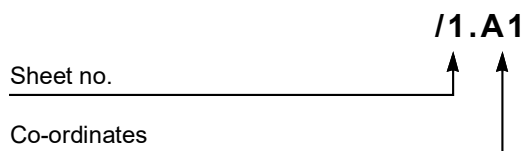

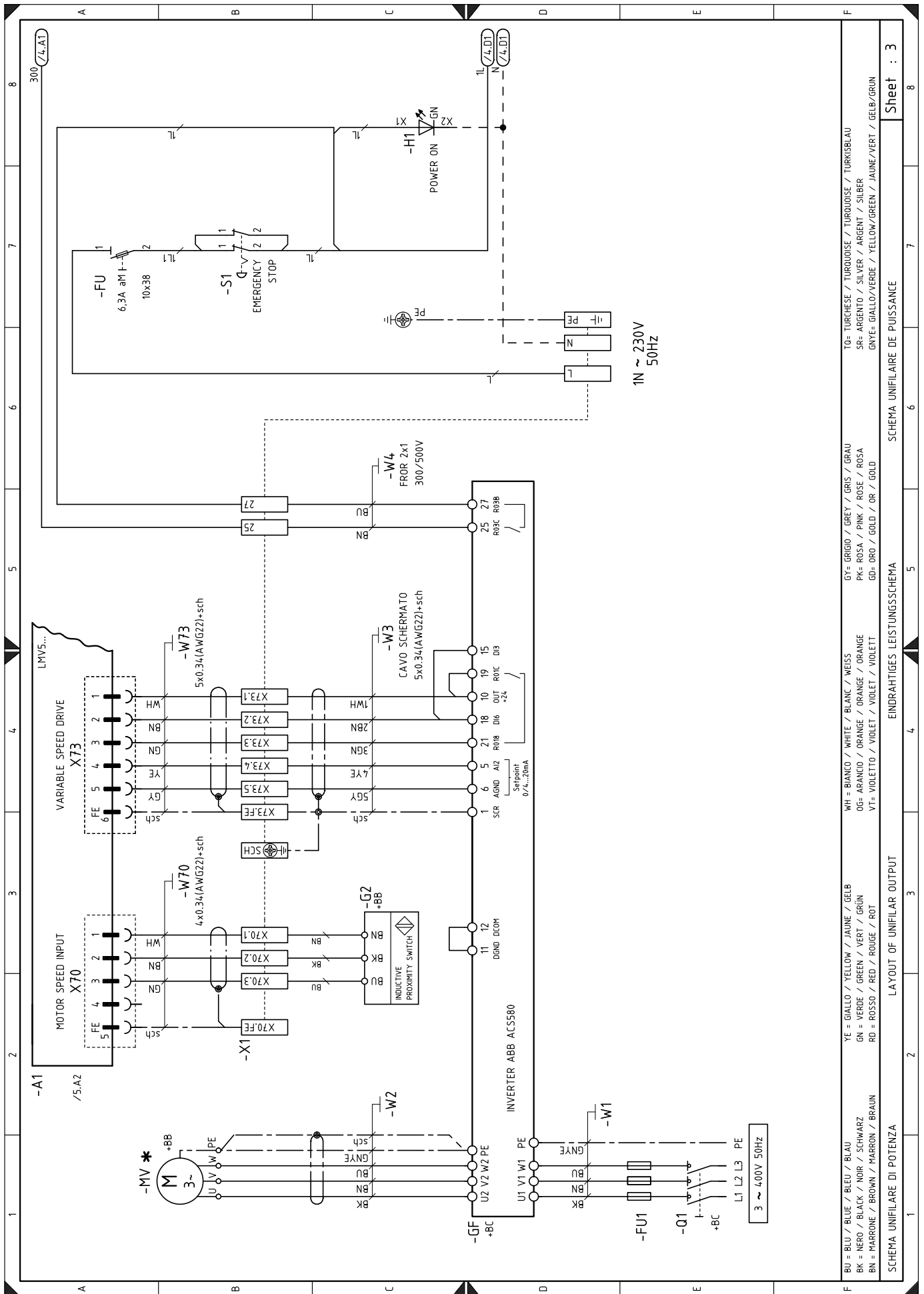

BU = BLU / BLUE / BLEU / BLAU	GY = GRIGIO / GREY / GRIS / GRAU	TO = TURCHESE / TURQUOISE / TURQUOISE / TURKISBLAU
BK = NERO / BLACK / NOIR / SCHWARZ	PK = ROSA / PINK / ROSE / ROSA	SR = ARGENTO / SILVER / ARGENT / SILBER
BN = MARRONE / BROWN / MARRON / BRAUN	GD = ORO / GOLD / OR / GOLD	GNTE = GIALLO/VERDE / YELLOW/GREEN / JAUNE/VERT / GELB/GRÜN
YE = GIALLO / YELLOW / JAUNE / GELB	OG = ARANCIO / ORANGE / ORANGE / ORANGE	
GN = VERDE / GREEN / VERT / GRÜN	VI = VIOLETT / VIOLET / VIOLET / VIOLETT	
RD = ROSSO / RED / ROUGE / ROT		

Sheet : 3

SCHEMA UNIFILARE DE PUISSANCE

EINDRÄHTIGES LEISTUNGSSCHEMA

LAYOUT OF UNIFILAR OUTPUT

SCHEMA UNIFILARE DI POTENZA

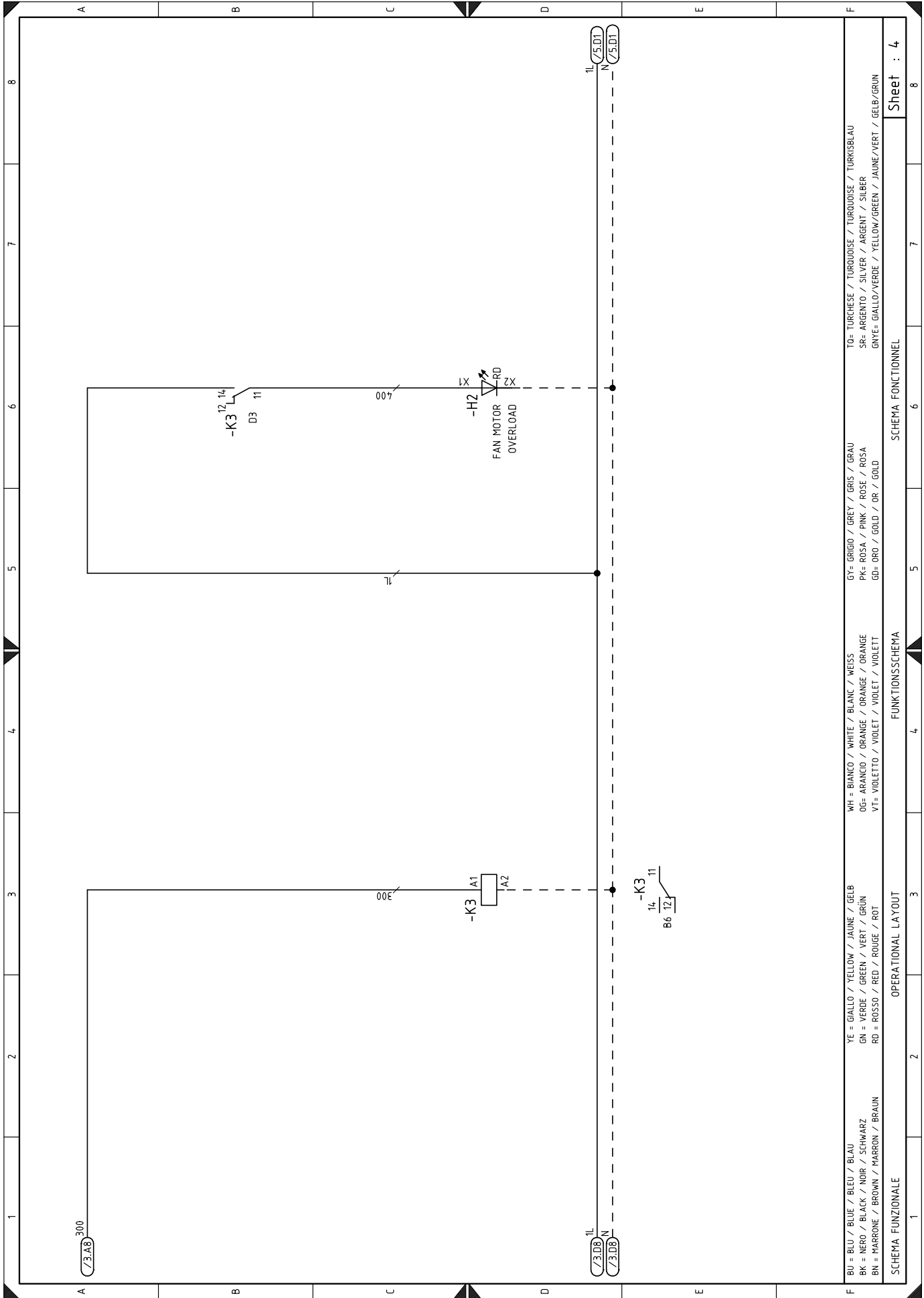

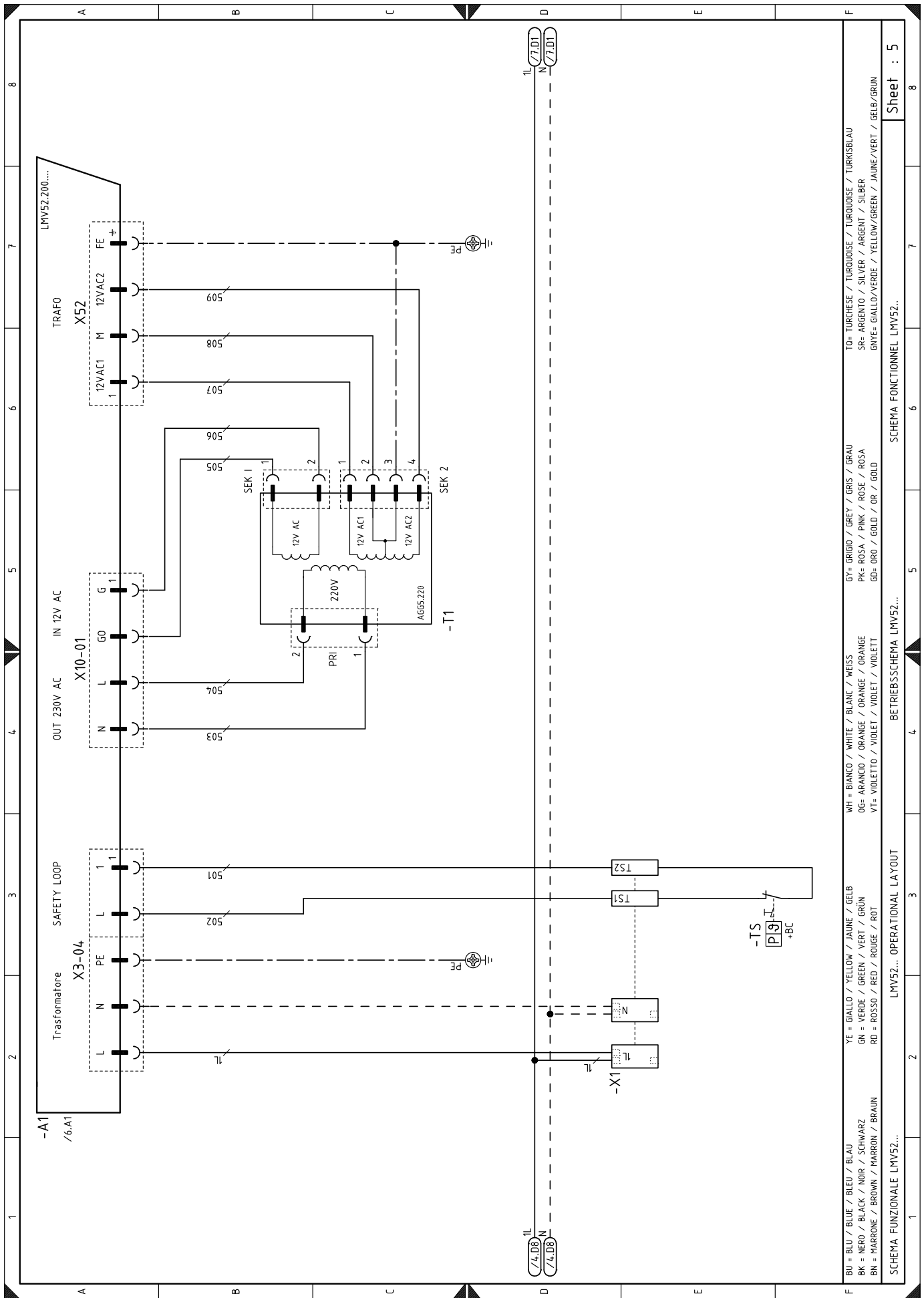

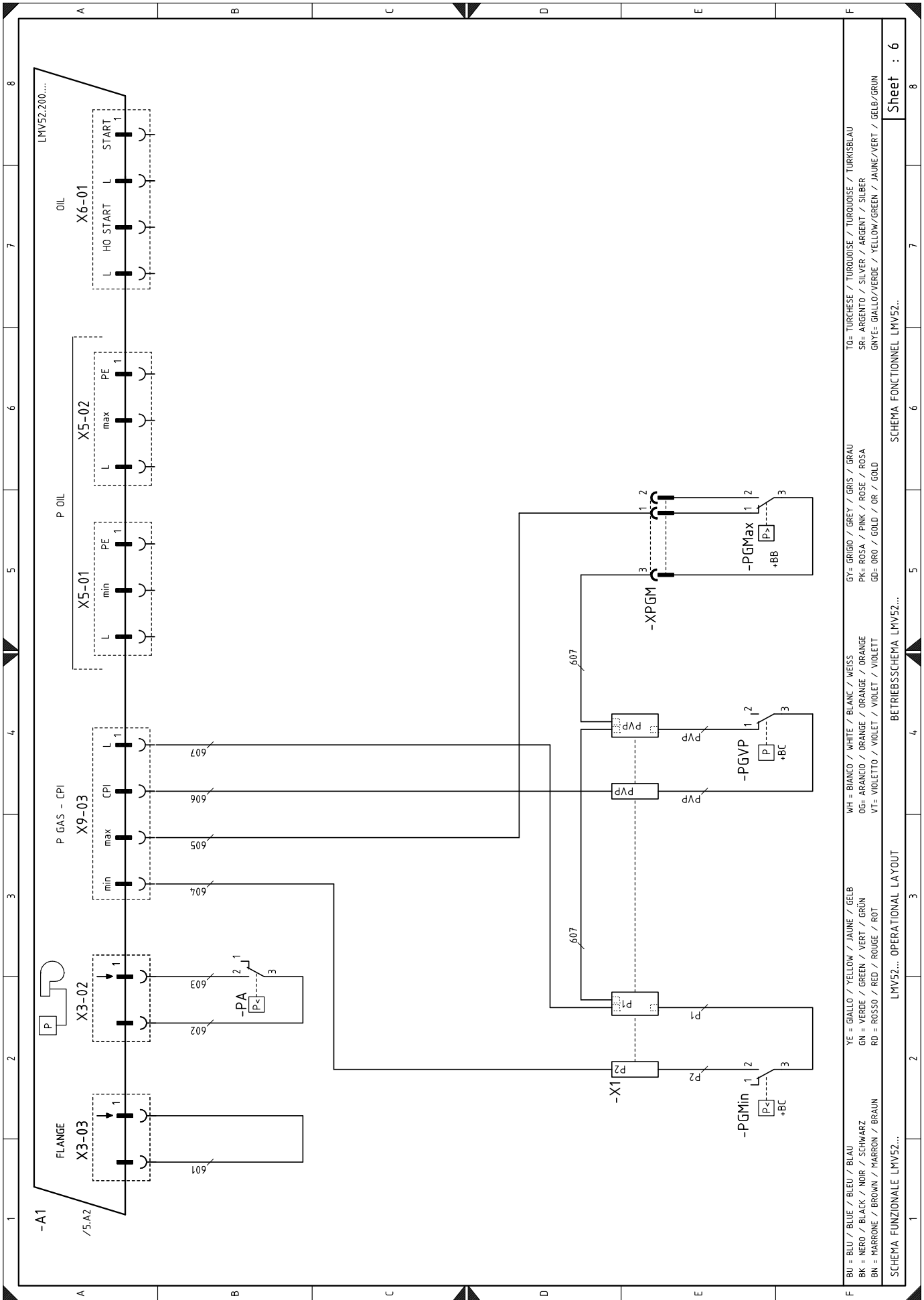

BU = BLU / BLUE / BLEU / BLAU
 BK = NERO / BLACK / NOIR / SCHWARZ
 BN = MARRONE / BROWN / MARRON / BRAUN
 YE = GIALLO / YELLOW / JAUNE / GELB
 GN = VERDE / GREEN / VERT / GRÜN
 RD = ROSSO / RED / ROUGE / ROT
 WH = BIANCO / WHITE / BLANC / WEISS
 OG = ARANCIO / ORANGE / ORANGE / ORANGE
 VT = VIOLETTA / VIOLET / VIOLET / VIOLETT
 GR = GRIGIO / GREY / GRIS / GRAU
 PK = ROSA / PINK / ROSE / ROSA
 GD = ORO / GOLD / OR / GOLD
 TO = TURCHESE / TURQUOISE / TURQUOISE / TURKISBLAU
 SR = ARGENTO / SILVER / ARGENT / SILBER
 GRY = GIALLO/VERDE / YELLOW/GREEN / JAUNE/VERT / GELB/GRÜN

SCHEMA FUNZIONALE LMV52...
 SCHEMA FONCTIONNEL LMV52...
 BETRIEBSSCHEMA LMV52...
 OPERATIONAL LAYOUT

Sheet : 6

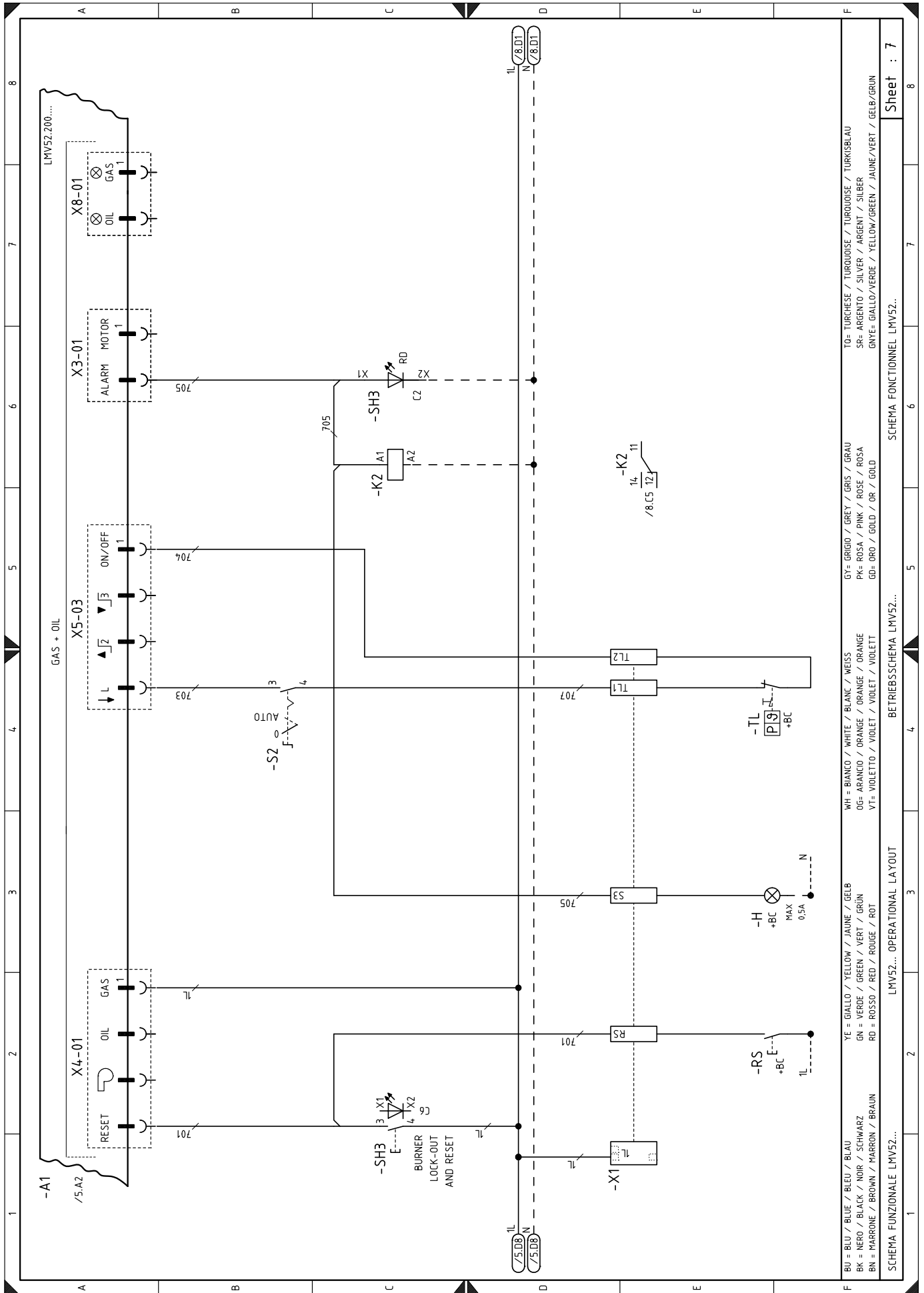

BU = BLU / BLUE / BLEU / BLAU	WH = BIANCO / WHITE / BLANC / WEISS	GY = GRIGIO / GREY / GRIS / GRAU	TO = TURCHESE / TURQUOISE / TURKUISE / TURKISBLAU
BK = NERO / BLACK / NOIR / SCHWARZ	OG = ARANCIO / ORANGE / ORANGE / ORANGE	PK = ROSA / PINK / ROSE / ROSA	SR = ARGENTO / SILVER / ARGENT / SILBER
BN = MARRONE / BROWN / MARRON / BRAUN	VI = VIOLETTA / VIOLET / VIOLET / VIOLETT	GD = ORO / GOLD / OR / GOLD	GNTE = GIALLO/VERDE / YELLOW/GREEN / JAUNE/VERT / GELB/GRUN

Sheet : 7

SCHEMA FONCTIONNEL LMV52...

BETRIEBSSCHEMA LMV52...

LMV52... OPERATIONAL LAYOUT

SCHEMA FUNZIONALE LMV52...

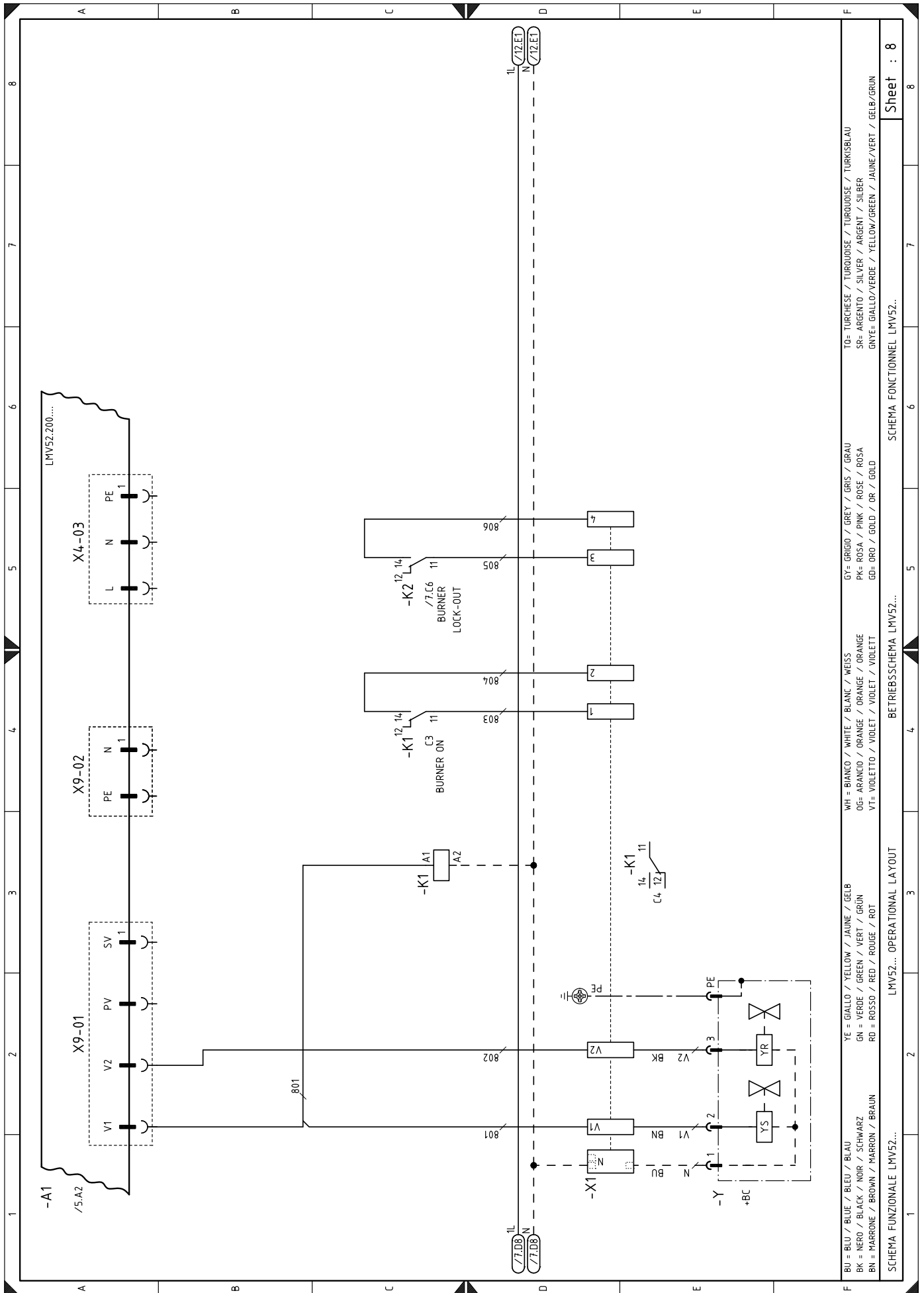

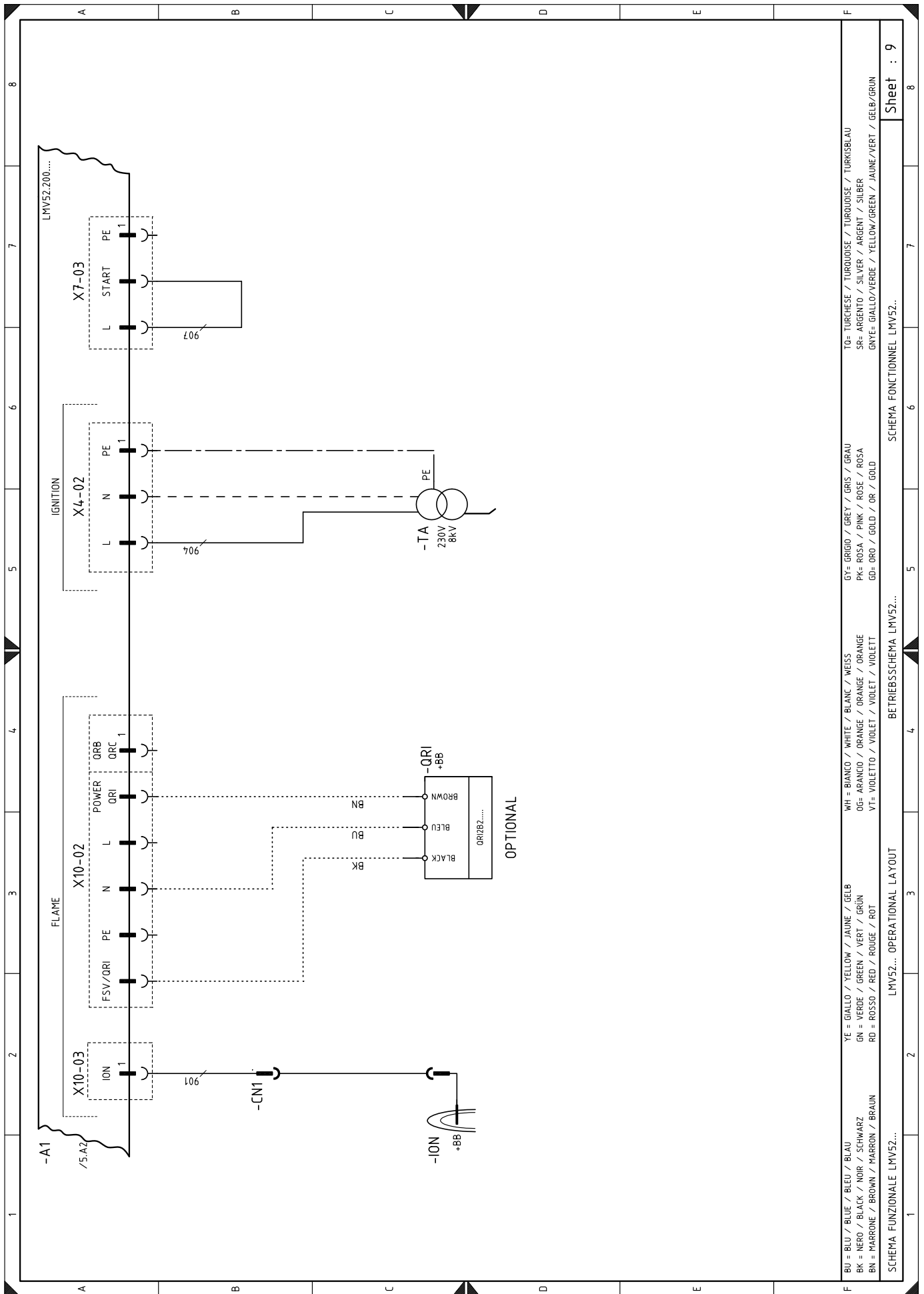

BU = BLU / BLUF / BLEU / BLAU	YE = GIALLO / YELLOW / JAUNE / GELB	WH = BIANCO / WHITE / BLANC / WEISS	GY = GRIGIO / GREY / GRIS / GRAU	TO= TURCHESE / TURQUOISE / TURKISBLAU
BK = NERO / BLACK / NOIR / SCHWARZ	GN = VERDE / GREEN / VERT / GRÜN	OG= ARANCIO / ORANGE / ORANGE / ORANGE	PK= ROSA / PINK / ROSE / ROSA	SR= ARGENTO / SILVER / ARGENT / SILBER
BN = MARRONE / BROWN / MARRON / BRAUN	RD = ROSSO / RED / ROUGE / ROT	VI= VIOLETTIO / VIOLET / VIOLET / VIOLETT	GD= ORO / GOLD / OR / GOLD	GNTE= GIALLO/VERDE / YELLOW/GREEN / JAUNE/VERT / GELB/GRÜN

SCHEMA FUNZIONALE LMV52... LMV52... OPERATIONAL LAYOUT SCHEMA FONCTIONNEL LMV52... Sheet : 9

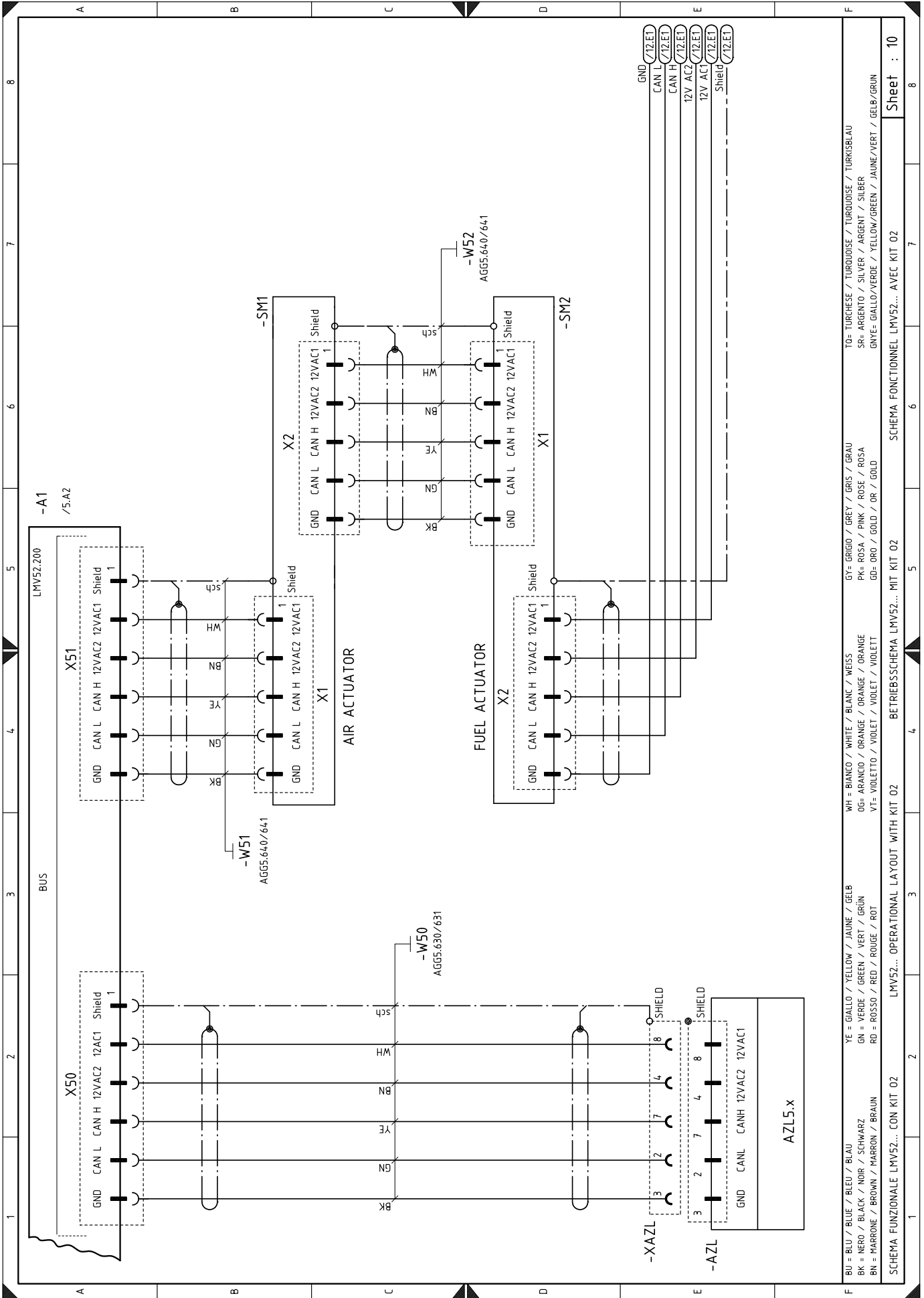

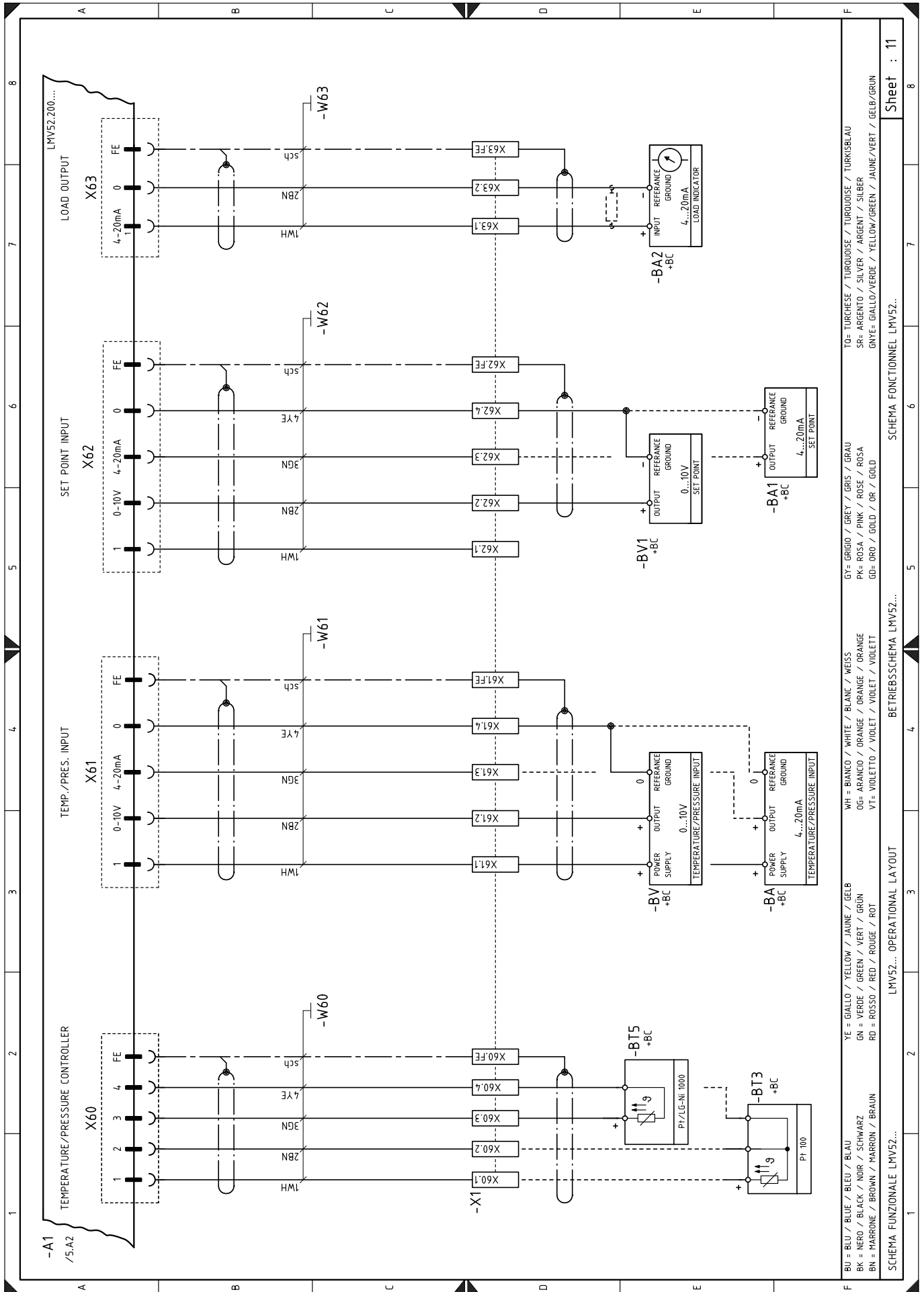

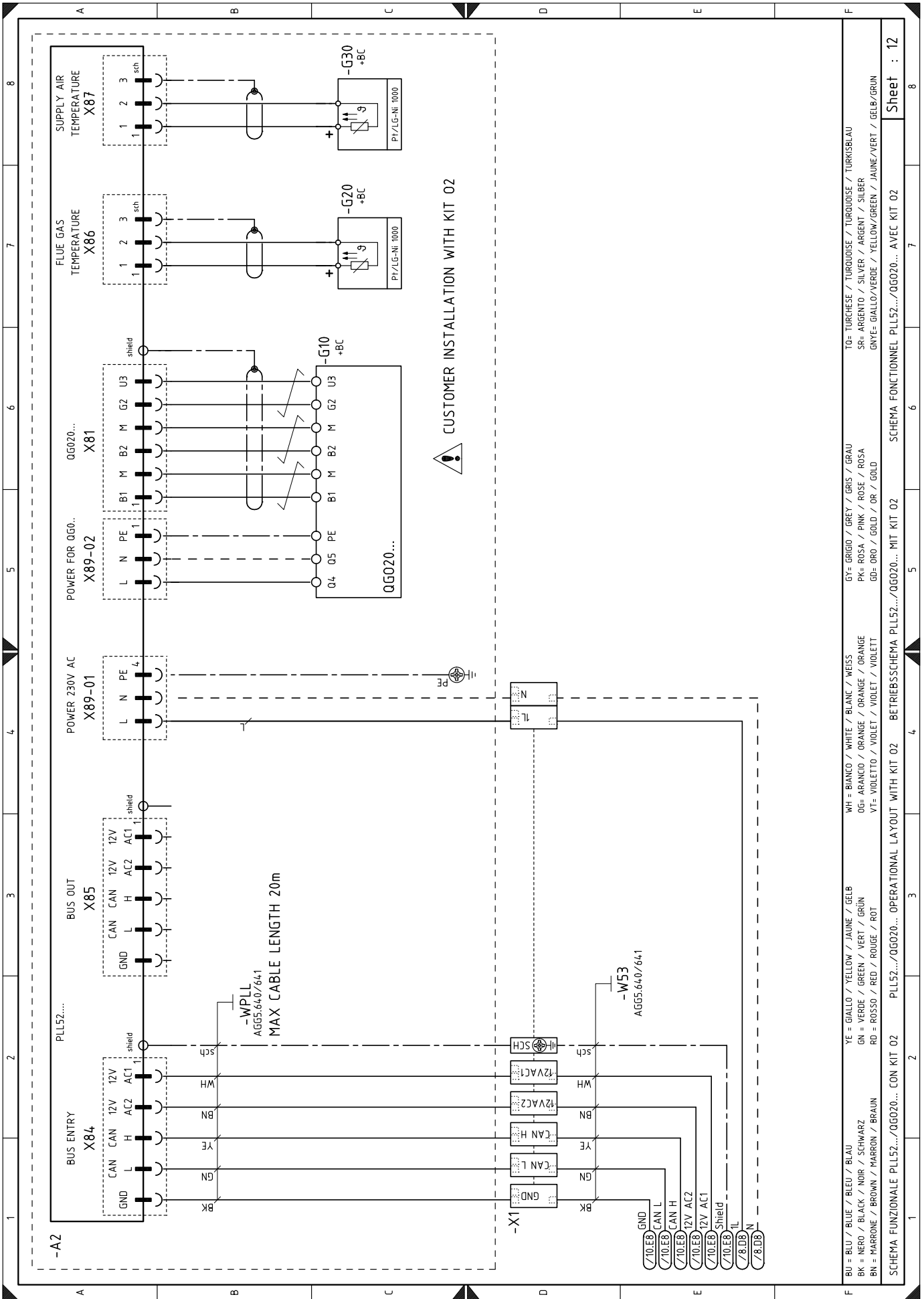

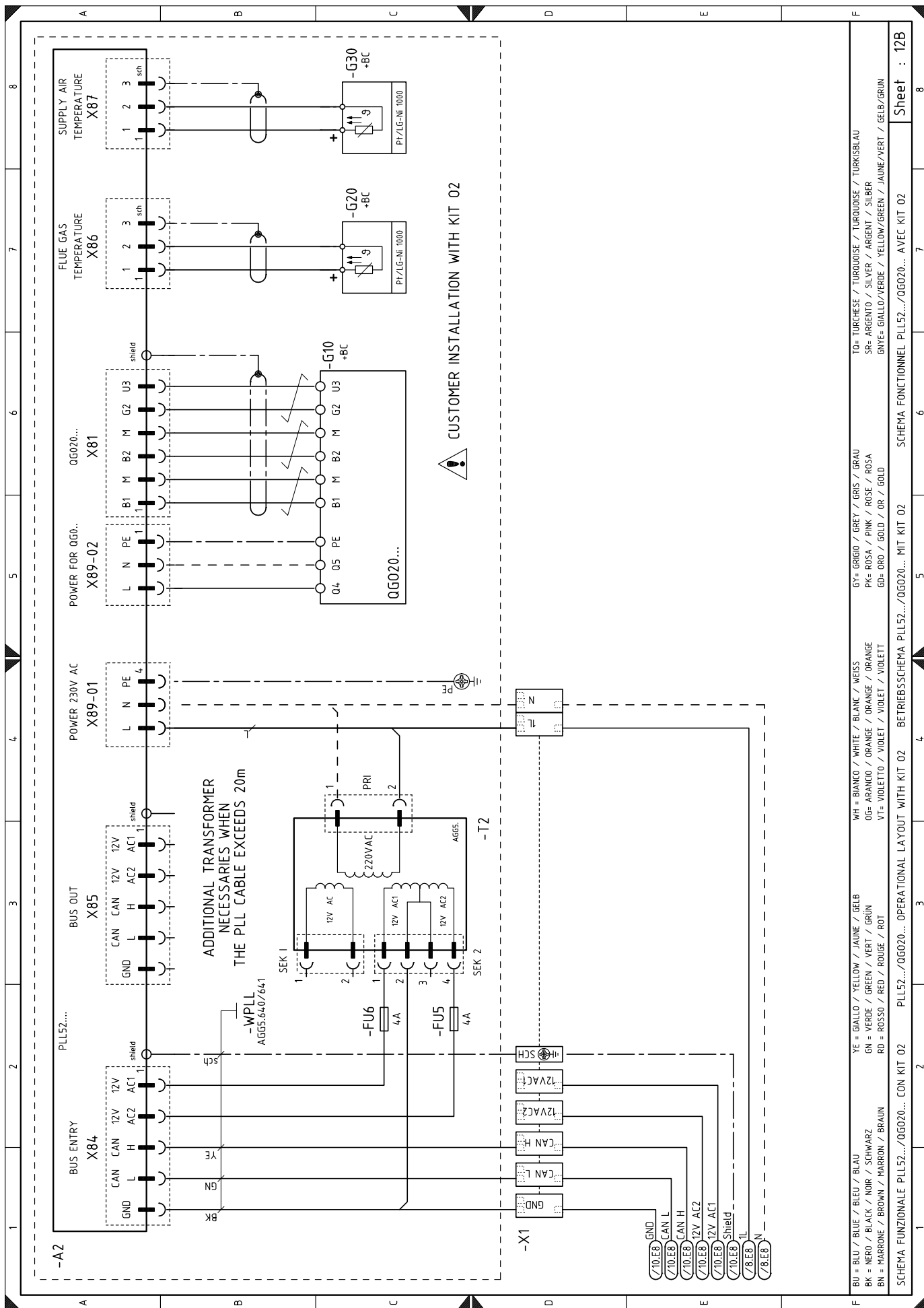

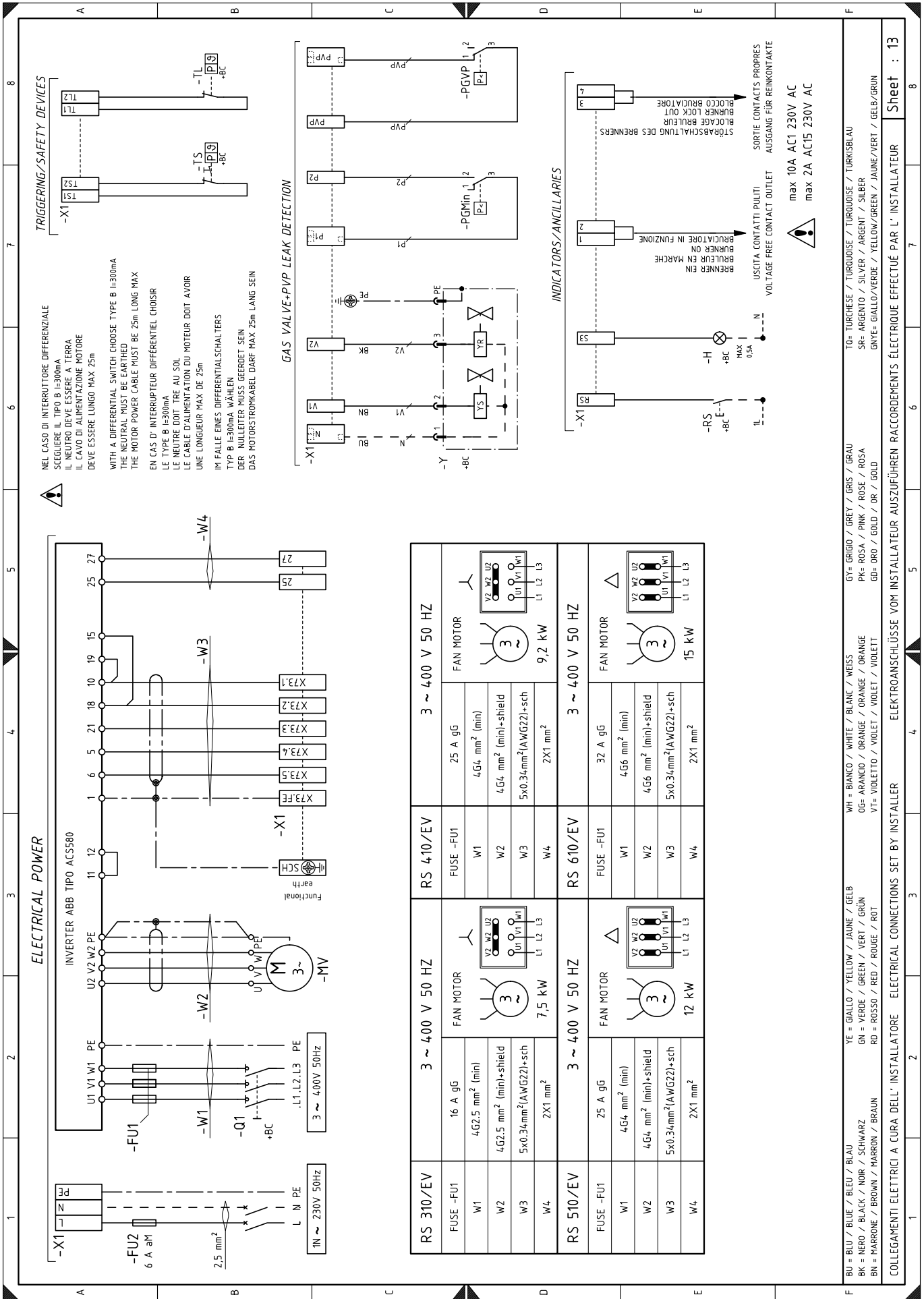

NEL CASO DI INTERRUPTORE DIFFERENZIALE
 SCEGLIERE IL TIPO B I=300mA
 IL NEUTRO DEVE ESSERE A TERRA
 IL CAVO DI ALIMENTAZIONE MOTORE
 DEVE ESSERE LUNGO MAX 25m

WITH A DIFFERENTIAL SWITCH CHOOSE TYPE B I=300mA
 THE NEUTRAL MUST BE EARTHED
 THE MOTOR POWER CABLE MUST BE 25m LONG MAX

EN CAS D'INTERRUPTEUR DIFFERENTIEL CHOISIR
 LE TYPE B I=300mA
 LE CABLE D'ALIMENTATION DU MOTEUR DOIT AVOIR
 UNE LONGUEUR MAX DE 25m

IM FALLE EINES DIFFERENTIALSCHALTERS
 WÄHLEN DER NULLEITER MUSS GEERDET SEIN
 DAS MOTORSTROMKABEL DARF MAX 25m LANG SEIN

GAS VALVE+PVP LEAK DETECTION

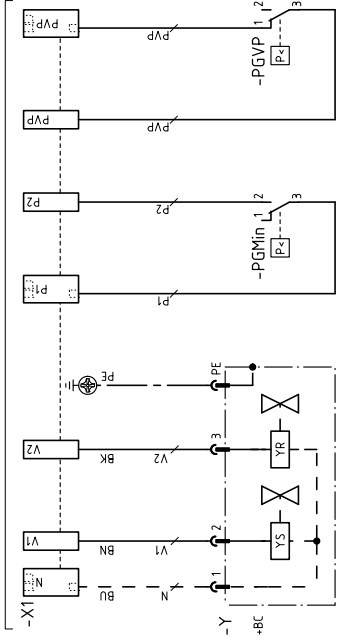

INDICATORS/ANCILLARIES

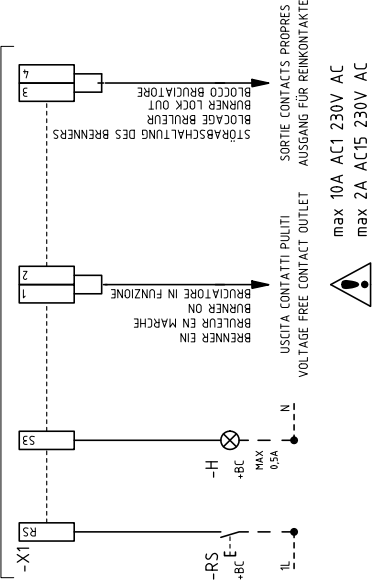

RS 310/EV	RS 410/EV	RS 510/EV	RS 610/EV
FUSE -FU1	FUSE -FU1	FUSE -FU1	FUSE -FU1
W1	W1	W1	W1
W2	W2	W2	W2
W3	W3	W3	W3
W4	W4	W4	W4
FAN MOTOR	FAN MOTOR	FAN MOTOR	FAN MOTOR
16 A gG	25 A gG	25 A gG	32 A gG
4G2.5 mm ² (min)	4G4 mm ² (min)	4G4 mm ² (min)	4G6 mm ² (min)
4G2.5 mm ² (min)+shield	4G4 mm ² (min)+shield	4G4 mm ² (min)+shield	4G6 mm ² (min)+shield
5x0.34mm ² (AWG22)+sch	5x0.34mm ² (AWG22)+sch	5x0.34mm ² (AWG22)+sch	5x0.34mm ² (AWG22)+sch
2X1 mm ²	2X1 mm ²	2X1 mm ²	2X1 mm ²
7.5 kW	9.2 kW	12 kW	15 kW

BU = BLU / BLUE / BLEU / BLAU
BN = MARRONE / BROWN / MARRON / BRAUN
BK = NERO / BLACK / NOIR / SCHWARZ
GN = VERDE / GREEN / VERT / GRÜN
GR = GRIGIO / GREY / GRIS / GRAU
GY = GIALLO / YELLOW / JAUNE / GELB
OR = ARANCIO / ORANGE / ORANGE / ORANGE
PK = ROSA / PINK / ROSE / ROSA
RD = ROSSO / RED / ROUGE / ROT
VI = VIOLETTA / VIOLET / VIOLET / VIOLETT
VT = VIOLETTA / VIOLET / VIOLET / VIOLETT
WH = BIANCO / WHITE / BLANC / WEISS
YG = GIALLO / YELLOW / JAUNE / GELB
YE = GIALLO / YELLOW / JAUNE / GELB
ZN = ZINCO / ZINC / ZINC / ZINC

TO= TURCHESE / TURQUOISE / TURKOISE / TURKISBLAU
 SR= ARGENTO / SILVER / ARGENT / SILBER
 GN= GIALLO/VERDE / YELLOW/GREEN / JAUNE/VERT / GELB/GRÜN

COLLEGAMENTI ELETTRICI A CURA DELL'INSTALLATORE ELECTRICAL CONNECTIONS SET BY INSTALLER ELEKTROANSCHLÜSSE VOM INSTALLATEUR AUSZUFÜHREN RACCORDEMENTS ÉLECTRIQUE EFFECTUÉ PAR L'INSTALLATEUR

max 10A AC1 230V AC
 max 2A AC15 230V AC

Sheet : 13

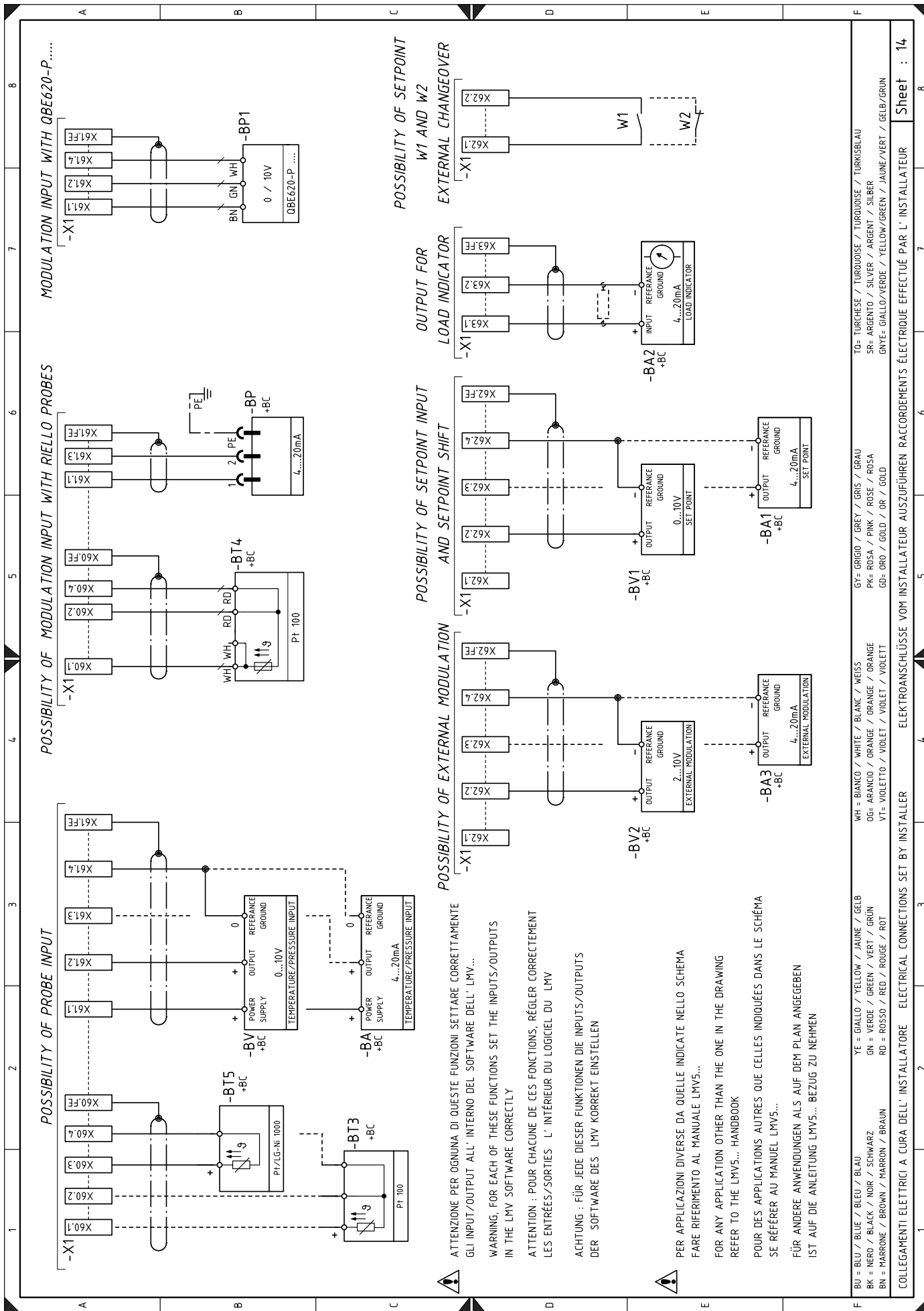

POSSIBILITY OF PROBE INPUT

POSSIBILITY OF MODULATION INPUT WITH RIELLO PROBES

MODULATION INPUT WITH QBE620-P.....

ATTENZIONE PER OGNIUNA DI QUESTE FUNZIONI SETTARE CORRETTAMENTE GLI INPUT/OUTPUT ALL' INTERNO DEL SOFTWARE DELL' LMV...

WARNING, FOR EACH OF THESE FUNCTIONS SET THE INPUTS/OUTPUTS IN THE LMV SOFTWARE CORRECTLY

ATTENTION : POUR CHACUNE DE CES FONCTIONS, RÉGLER CORRECTEMENT LES ENTRÉES/SORTIES L' INTÉRIEUR DU LOGICIEL DU LMV

ACHTUNG : FÜR JEDE DIESER FUNKTIONEN DIE INPUTS/OUTPUTS DER SOFTWARE DES LMV KORREKT EINSTELLEN

PER APPLICAZIONI DIVERSE DA QUELLE INDICATE NELLO SCHEMA FARE RIFERIMENTO AL MANUALE LMV5...

FOR ANY APPLICATION OTHER THAN THE ONE IN THE DRAWING REFER TO THE LMV5... HANDBOOK

POUR DES APPLICATIONS AUTRES QUE CELLES INDiquÉES DANS LE SCHEMA SE RÉFÉRER AU MANUEL LMV5...

FÜR ANDERE ANWENDUNGEN ALS AUF DEM PLAN ANGEZEIGT IST AUF DIE ANLEITUNG LMV5... BEZUG ZU NEHMEN

POSSIBILITY OF SETPOINT W1 AND W2 EXTERNAL CHANGEOVER

OUTPUT FOR LOAD INDICATOR

POSSIBILITY OF SETPOINT INPUT AND SETPOINT SHIFT

POSSIBILITY OF EXTERNAL MODULATION

BU = BLU / BLUE / BLEU / BLAU	YE = GIALLO / YELLOW / JAUNE / GELB	WH = BIANCO / WHITE / BLANC / WEISS	GY= GRIGIO / GREY / GRIS / GRAU	TO= TURCHESE / TURKDOUSE / TURKDOUSE / TURKISBLAU
BK = NERO / BLACK / NOIR / SCHWARZ	GN = VERDE / GREEN / VERT / GRÜN	OG= ARANCIO / ORANGE / ORANGE / ORANGE	PK= ROSA / PINK / ROSE / ROSA	SR= ARGENTO / SILVER / ARGENT / SILBER
BN = MARRONE / BROWN / MARRON / BRAUN	RD = ROSSO / RED / ROUGE / ROT	VT= VIOLETTO / VIOLET / VIOLET / VIOLETT	GD= ORO / GOLD / OR / GOLD	GNVE= GIALLO/VERDE / YELLOW/GREEN / JAUNE/VERT / GELB/GRÜN

Wiring layout key

A1	Flame control
A2	O2 module PLL.. type
AZL	Display and calibration unit
BA	Output probe in current
BA1	Device with output undercurrent, for modifying remote setpoint
BA2	Load indicator
BA3	Input in current DC 4...20 mA
BP	Pressure probe
BP1	Pressure probe
BT3	Probe Pt100, 3 wires
BT4	Probe Pt100, 3 wires
BT5	PT/LG-Ni1000 probe
BV	Output probe in voltage
BV1	Output device in voltage to modify remote setpoint
CN1	Ionisation probe connector
FU	Auxiliary circuits safety fuse
GF	Inverter
G2	Rpm sensor
G10	O2 sensor OGO20 type
G20	Combustion fume temperature sensor probe
G30	Air temperature control probe
H	Burner working lighting signal output
H1	Light signalling of mains live state
H2	Fan motor lock-out warning lamp
ION	Ionisation probe
K1	Clean contacts output relay burner switched on
K2	Clean contacts output relay burner lockout
K3	Clean contacts output relay VSD alarm
MV	Fan motor
PA	Air pressure switch
PE	Burner earth
PGMax	Maximum gas pressure switch
PGMin	Minimum gas pressure switch
PGVP	Gas pressure switch for valve leak detection control device
QRI	Infrared sensor
RS	Burner reset switch
SM1	Air servomotor
SM2	Gas servomotor
S1	Emergency stop button
S2	Automatic / off selector
SH3	Burner reset button and light signalling of lock-out signal
TA	Ignition transformer
TL	Limit thermostat/pressure switch
TS	Safety thermostat/pressure switch
T1	Electronic cam transformer
T2	Additional transformer
Y	Gas regulator valve + gas safety valve
X1	Main terminal supply board
XAZL	Plug for on board display
XPGMax	Maximum gas pressure switch connector

RIELLO

RIELLO S.p.A.
I-37045 Legnago (VR)
Tel.: +39.0442.630111
[http:// www.riello.it](http://www.riello.it)
[http:// www.riello.com](http://www.riello.com)