

GB **Dual fuel light oil/ gas burners**

Modulating operation

CE

**UK
CA**

EAC

CODE	MODEL	TYPE
20182022	RLS 310/EV O2 MX	1161T2
20182023	RLS 410/EV O2 MX	1162T2
20182024	RLS 510/EV O2 MX	1163T2
20182026	RLS 610/EV O2 MX	1164T2



Translation of the original instructions

1	Information and general warnings.....	3
1.1	Information about the instruction manual	3
1.2	Guarantee and responsibility.....	4
2	Safety and prevention.....	5
2.1	Introduction.....	5
2.2	Personnel training	5
3	Technical description of the burner	6
3.1	Burner designation	6
3.2	Models available.....	6
3.3	Burner categories - Countries of destination	7
3.4	Technical data	7
3.5	Electrical data.....	7
3.6	Maximum dimensions.....	8
3.7	Firing rates	9
3.8	Test boiler.....	10
3.9	Burner equipment.....	10
3.10	Burner description	11
3.11	Electrical panel description.....	12
3.12	Flame control (LMV52...).....	13
3.13	Servomotor.....	15
3.14	PLL52... module (optional)	16
3.15	Oxygen sensor QGO20 ... (optional).....	17
3.16	Calibration of the thermal relay	19
4	Installation	20
4.1	Notes on safety for the installation	20
4.2	Handling	20
4.3	Preliminary checks	20
4.4	Operating position	21
4.5	Preparing the boiler	21
4.6	Securing the burner to the boiler	21
4.7	Access to head internal part.....	22
4.8	Position of the electrodes and central gas nozzles	22
4.9	Gas butterfly valve.....	23
4.10	Combustion head adjustment.....	23
4.11	Nozzle installation	24
4.12	Light oil supply.....	25
4.13	Gas pressures	28
4.14	Electrical wiring	31
5	Start-up, calibration and operation of the burner	33
5.1	Notes on safety for the first start-up	33
5.2	Adjustments prior to ignition (light oil)	33
5.3	Burner ignition (light oil).....	33
5.4	Adjustments prior to ignition (gas).....	34
5.5	Burner start-up (gas)	34
5.6	Burner ignition	34
5.7	Change of fuel.....	34
5.8	Air / fuel adjustment.....	35
5.9	Final adjustment of the pressure switches	36
5.10	Pressure switch adjustment	37

5.11	Operation	38
5.12	Ignition failure	39
5.13	Burner flame goes out during operation	39
5.14	Stopping of the burner	39
5.15	Final checks	39
5.16	Pump motor lock-out	39
5.17	Description of O2 trim control (optional)	40
6	Maintenance	41
6.1	Notes on safety for the maintenance	41
6.2	Maintenance programme	41
6.3	Checking the position of the rpm sensor	44
6.4	Opening the burner	45
6.5	Closing the burner	45
7	Faults - Possible causes - Solutions	46
A	Appendix - Accessories	47
B	Appendix - Electrical panel layout	48

1 Information and general warnings

1.1 Information about the instruction manual

1.1.1 Introduction

The instruction manual supplied with the burner:

- is an integral and essential part of the product and must not be separated from it; it must therefore be kept carefully for any necessary consultation and must accompany the burner even if it is transferred to another owner or user, or to another system. If the manual is lost or damaged, another copy must be requested from the Technical Assistance Service of the area;
- is designed for use by qualified personnel;
- offers important indications and instructions relating to the installation safety, start-up, use and maintenance of the burner.

Symbols used in the manual

In some parts of the manual you will see triangular DANGER signs. Pay great attention to these, as they indicate a situation of potential danger.

1.1.2 General dangers

The **dangers** can be of **3 levels**, as indicated below.



Maximum danger level!
This symbol indicates operations which, if not carried out correctly, cause serious injury, death or long-term health risks.



This symbol indicates operations which, if not carried out correctly, may cause serious injury, death or long-term health risks.



This symbol indicates operations which, if not carried out correctly, may cause damage to the machine and/or injury to people.

1.1.3 Other symbols



DANGER: LIVE COMPONENTS
This symbol indicates operations which, if not carried out correctly, lead to electric shocks with lethal consequences.



DANGER: FLAMMABLE MATERIAL
This symbol indicates the presence of flammable materials.



DANGER: BURNING
This symbol indicates the risks of burns due to high temperatures.



DANGER: CRUSHING OF LIMBS
This symbol indicates the presence of moving parts: danger of crushing of limbs.



WARNING: MOVING PARTS
This symbol indicates that you must keep limbs away from moving mechanical parts; danger of crushing.



DANGER: EXPLOSION
This symbol signals places where an explosive atmosphere may be present. An explosive atmosphere is defined as a mixture - under atmospheric conditions - of air and flammable substances in the form of gases, vapours, mist or dust in which, after ignition has occurred, combustion spreads to the entire unburned mixture.



PERSONAL PROTECTION EQUIPMENT
These symbols indicate the equipment that must be worn and kept by the operator for protection against threats against safety and/or health while at work.



OBLIGATION TO ASSEMBLE THE COVER AND ALL THE SAFETY AND PROTECTION DEVICES
This symbol signals the obligation to reassemble the cover and all the safety and protection devices of the burner after any maintenance, cleaning or checking operations.



ENVIRONMENTAL PROTECTION
This symbol gives indications for the use of the machine with respect for the environment.



IMPORTANT INFORMATION
This symbol indicates important information that you must bear in mind.

- This symbol indicates a list.

Abbreviations used

Ch.	Chapter
Fig.	Figure
Page	Page
Sec.	Section
Tab.	Table

1.1.4 Delivery of the system and the instruction manual

When the system is delivered, it is important that:

- the instruction manual is delivered to the user by the system manufacturer, with the recommendation to keep it in the room where the heat generator is to be installed.
- The instruction manual shows:
 - the serial number of the burner;

.....

- the address and telephone number of the nearest Assistance Centre;

.....

- The system supplier must carefully inform the user about:
 - the use of the system;
 - any further tests that may be required before activating the system;
 - maintenance, and the need to have the system checked at least once a year by a representative of the manufacturer or another specialised technician.
 To ensure a periodic check, the manufacturer recommends the drawing up of a Maintenance Contract.

1.2 Guarantee and responsibility

The manufacturer guarantees its new products from the date of installation, in accordance with the regulations in force and/or the sales contract. At the moment of the first start-up, check that the burner is integral and complete.



WARNING

Failure to observe the information given in this manual, operating negligence, incorrect installation and carrying out of non authorised modifications will result in the annulment by the manufacturer of the guarantee that it supplies with the burner.

In particular, the rights to the guarantee and the responsibility will no longer be valid, in the event of damage to things or injury to people, if such damage/injury was due to any of the following causes:

- incorrect installation, start-up, use and maintenance of the burner;
- improper, incorrect or unreasonable use of the burner;
- intervention of unqualified personnel;
- carrying out of unauthorised modifications on the equipment;
- use of the burner with safety devices that are faulty, incorrectly applied and/or not working;
- installation of untested supplementary components on the burner;
- powering of the burner with unsuitable fuels;
- faults in the fuel supply system;
- continuation of use of the burner when a fault has occurred;
- repairs and/or overhauls incorrectly carried out;
- modification of the combustion chamber with inserts that prevent the regular development of the structurally established flame;
- insufficient and inappropriate surveillance and care of those burner components most likely to be subject to wear and tear;
- use of non-original components, including spare parts, kits, accessories and optional;
- force majeure.

The manufacturer furthermore declines any and every responsibility for the failure to observe the contents of this manual.

2 Safety and prevention

2.1 Introduction

The burners have been designed and built in compliance with current regulations and directives, applying the known technical rules of safety and envisaging all the potential danger situations. It is necessary, however, to bear in mind that the imprudent and clumsy use of the equipment may lead to situations of death risk for the user or third parties, as well as the damaging of the burner or other items. Inattention, thoughtlessness and excessive confidence often cause accidents; the same applies to tiredness and sleepiness.

It is a good idea to remember the following:

- The burner must only be used as expressly described. Any other use should be considered improper and therefore dangerous.

In particular:

it can be applied to boilers operating with water, steam, diathermic oil, and to other uses expressly foreseen by the manufacturer;

the type and pressure of the fuel, the voltage and frequency of the electrical power supply, the minimum and maximum deliveries for which the burner has been regulated, the pressurisation of the combustion chamber, the dimensions of the combustion chamber and the room temperature must all be within the values indicated in the instruction manual.

- Modification of the burner to alter its performance and destinations is not allowed.
- The burner must be used in exemplary technical safety conditions. Any disturbances that could compromise safety must be quickly eliminated.
- Opening or tampering with the burner components is not allowed, apart from the parts requiring maintenance.
- Only those parts envisaged by the manufacturer can be replaced.



The manufacturer guarantees safety and proper functioning only if all burner components are intact and positioned correctly.

2.2 Personnel training

The user is the person, body or company that has acquired the machine and intends to use it for the specific purpose. He is responsible for the machine and for the training of the people working around it.

The user:

- undertakes to entrust the machine exclusively to suitably trained and qualified personnel;
- undertakes to inform his personnel in a suitable way about the application and observance of the safety instructions. With that aim, the user undertakes to ensure that everyone knows the use and safety instructions for his own duties.
- Personnel must follow all the danger and caution indications shown on the machine.
- Personnel must not carry out, on their own initiative, operations or interventions that are not within their province.
- Personnel are obliged to inform their superiors of every problem or dangerous situation that may arise.
- The assembly of parts of other makes, or any modifications, can alter the characteristics of the machine and hence compromise operating safety. The manufacturing company therefore accepts no responsibility whatsoever for any which may result from the use of non-original parts.

In addition:



- must take all the measures necessary to prevent unauthorised people gaining access to the machine;
- the user must inform the manufacturer if faults or malfunctioning of the accident prevention systems are noticed, along with any presumed danger situation;
- personnel must always use the personal protective equipment envisaged by legislation and follow the indications given in this manual.

3 Technical description of the burner

3.1 Burner designation

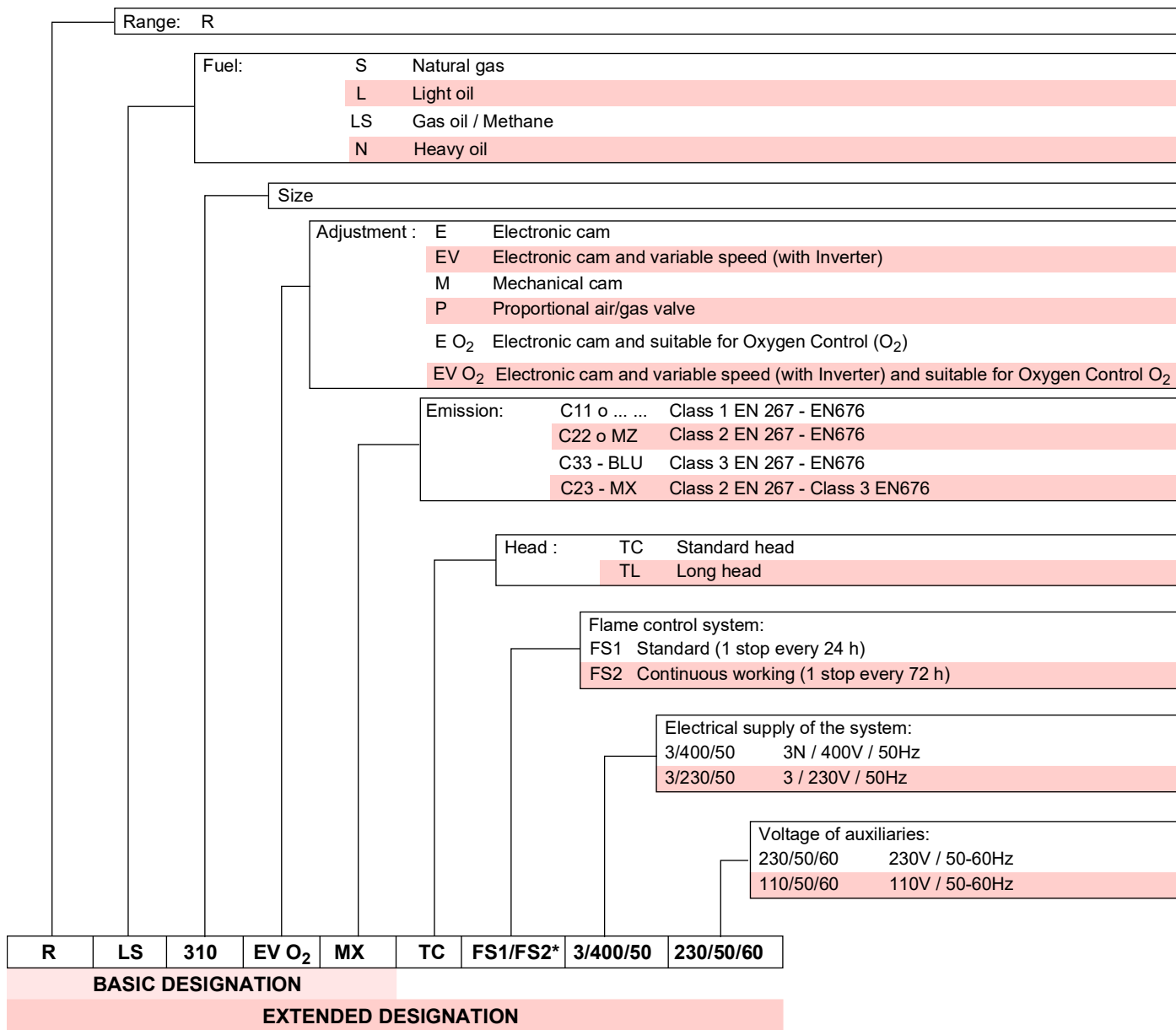

*The burner leaves the factory set up for FS1 operation. If FS2 operation is required, refer the specific manual to LMV 5...

3.2 Models available

Designation		Voltage	Start-up	Code
RLS 310/EV O ₂ MX	TC	3/400/50	Inverter	20182022
RLS 410/EV O ₂ MX	TC	3/400/50	Inverter	20182023
RLS 510/EV O ₂ MX	TC	3/400/50	Inverter	20182024
RLS 610/EV O ₂ MX	TC	3/400/50	Inverter	20182026

Tab. A

3.3 Burner categories - Countries of destination

Gas category	Destination country
I2E	LU - PL
I2E(R)	BE
I2EK	NL
I2ELL	DE
I2Er	FR
I2H	AT-GB-CH-CZ-DK-EE-ES-FI-GB-GR-HU-IE-IS-IT-LT-LV-NO-PT-RO-SE-SI-SK-TR

Tab. B

3.4 Technical data

Model			RLS 310/EV O2 MX	RLS 410/EV O2 MX	RLS 510/EV O2 MX	RLS 610/EV O2 MX
Power ⁽¹⁾ Delivery ⁽¹⁾	min - max	kW Kg/h	450/1200 ÷ 3600 50/100 ÷ 305	525/1500 ÷ 4200 55/126 ÷ 352	646/1800 ÷ 5170 56/152 ÷ 435	769/2200 ÷ 6155 110/185 ÷ 516
Fuels	Natural gas: G20 (methane gas) - G25 Light oil, max. viscosity at 20 °C: 6 mm ² /s (1.5°E - 6 cSt)					
Operation	FS1: Intermittent (min. 1 stop in 24 hours) FS2: Continuous (min. 1 stop in 72 hours) The burner leaves the factory set for the intermittent operation.					
Pump			TA 3	TA 4	TA 5	
Minimum output at 16.5 bar		kg/h	700	930	1270	
Pressure range		bar	7/40	7/40	7/30	
Fuel temperature		°C max	140			
Nozzles		number	1	1	1	1
Standard applications	Boilers: water, steam, diathermic oil					
Ambient temperature		°C	0 - 50			
Combustion air temperature		°C max	60			
Noise level ⁽²⁾						
Sound pressure		dB(A)	78	80	82,5	85
Sound power			89	91	93,5	96
Weight		kg	300			320
CE		N.	CE-0476DQ3601			

Tab. C

- (1) Reference conditions: Ambient temperature 20°C - Gas temperature 15°C - Barometric pressure 1013 mbar - Altitude 0 m a.s.l.
 (2) Sound pressure measured in manufacturer's combustion laboratory, with burner operating on test boiler and at maximum rated output. The sound power is measured with the "Free Field" method, as per EN 15036, and according to an accurate "Accuracy: Category 3", as described by EN ISO 3746".

3.5 Electrical data

Model			RLS 310/EV O2 MX	RLS 410/EV O2 MX	RLS 510/EV O2 MX	RLS 610/EV O2 MX
Main electrical supply	3N~ 400V +/-10% 50 Hz					
Absorbed electrical power						
Gas		kW max	9.1	10.7	13.6	17.2
Light oil			11	12.6	15.8	19.1
Protection level	IP 54					

Tab. D

3.6 Maximum dimensions

The maximum dimensions of the burner are given in Fig. 1.

Bear in mind that inspection of the combustion head requires the burner to be opened and the rear part turned on the hinge.

The maximum dimensions of the open burner are indicated by the L and R positions.

The I position is reference for the refractory thickness of the boiler door.



* The gas adaptor is set also for DN 80 bore.

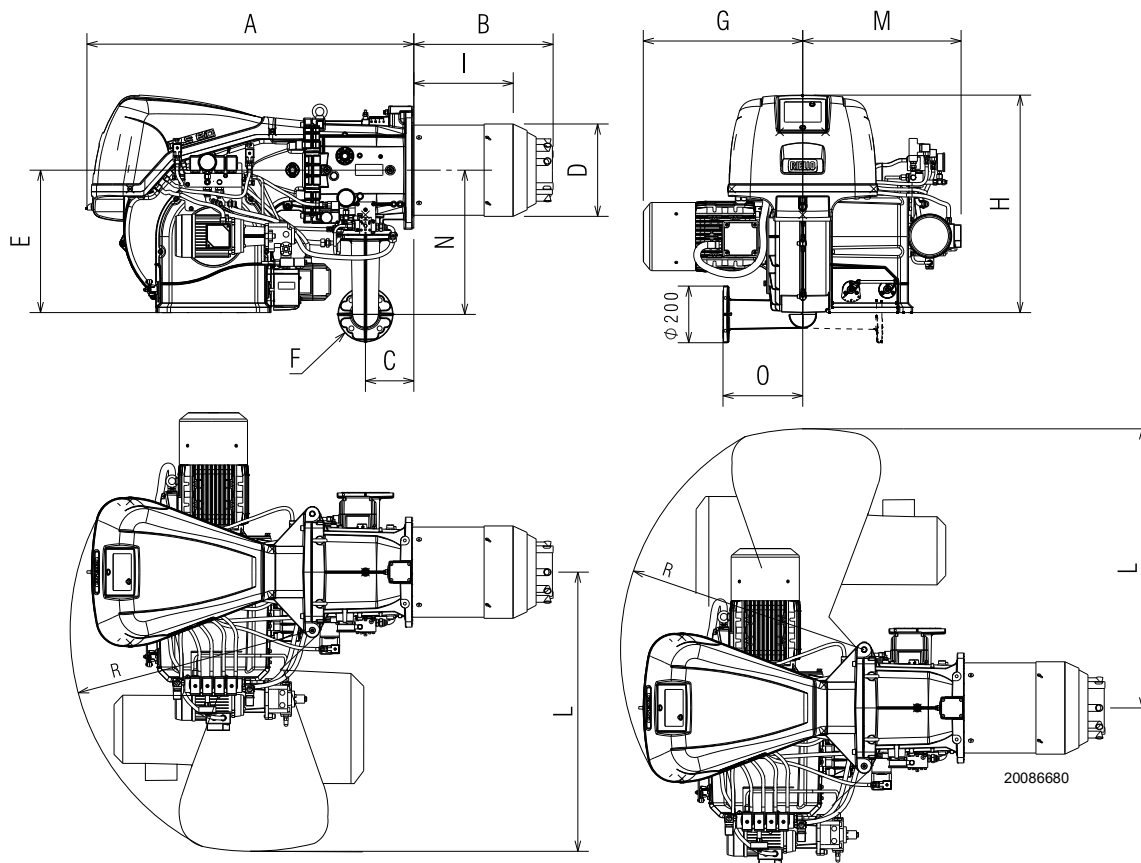

Fig. 1

mm	A	B	C	D	E	F*	G	H	I	L	M	N	O	R
RLS 310	1270	507	176	313	520	DN65	500	790	373	1178	596	528	290	970
RLS 410	1270	507	176	313	520	DN65	541	790	373	1178	596	528	290	970
RLS 510	1270	507	176	313	520	DN65	541	790	373	1178	596	528	290	970
RLS 610	1270	512	176	336	520	DN65	543	790	360	1178	596	528	290	970

Tab. E

3.7 Firing rates

The **MAXIMUM OUTPUT** is chosen from within the diagram area (Fig. 2).

The **MINIMUM OUTPUT** must not be lower than the minimum limit of the diagram:

Model	kW
RLS 310	450
RLS 410	525
RLS 510	646
RLS 610 Gas	769
RLS 610 Light oil	1300



The firing rate value (Fig. 2) has been obtained considering an ambient temperature of 20 °C, an atmospheric pressure of 1013 mbar (approx. 0 m a.s.l.), and with the combustion head adjusted as shown on page 23.



Pre-calibration of the combustion head only for the burner model RLS 310/M MX:

If the maximum burner output of the burner falls within:

- area A of the firing rate, it is necessary to replace the gas nozzles with those supplied (No. 8 gas nozzles Ø 5,3), Fig. 16 on page 22.
- area B of the firing rate, no modifications are required.

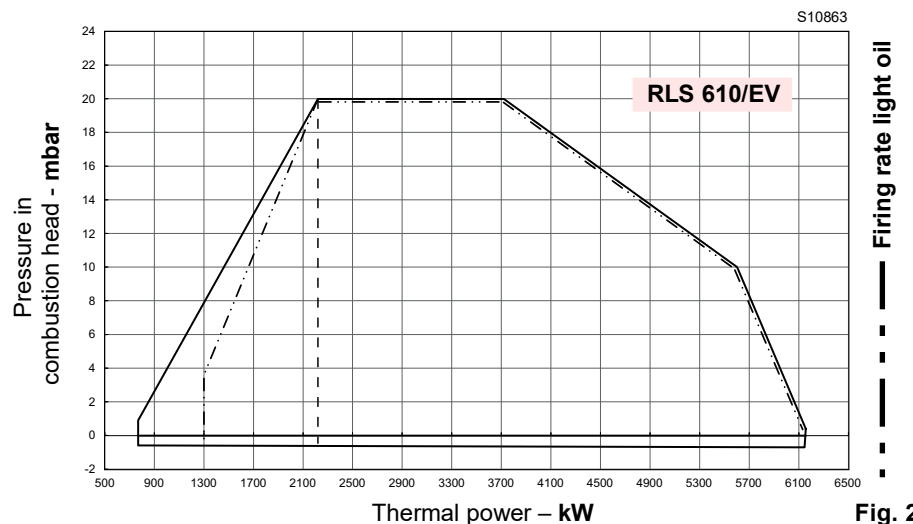
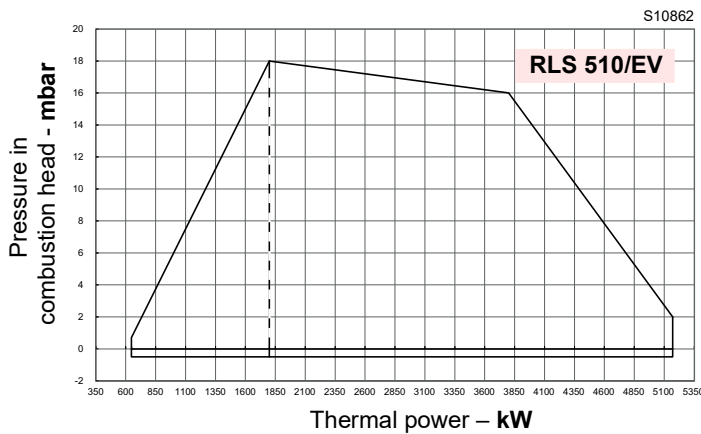
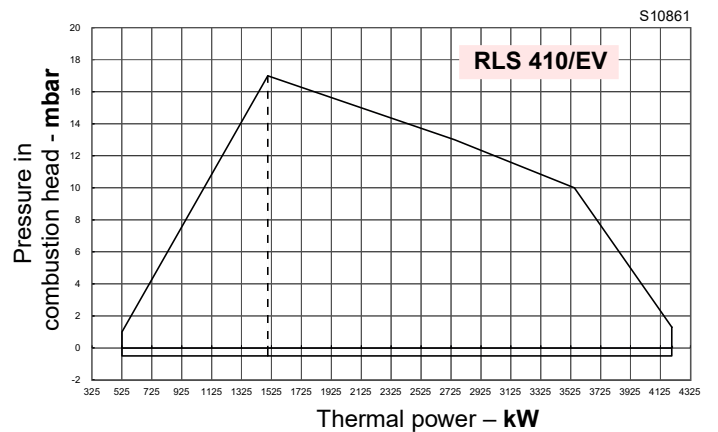
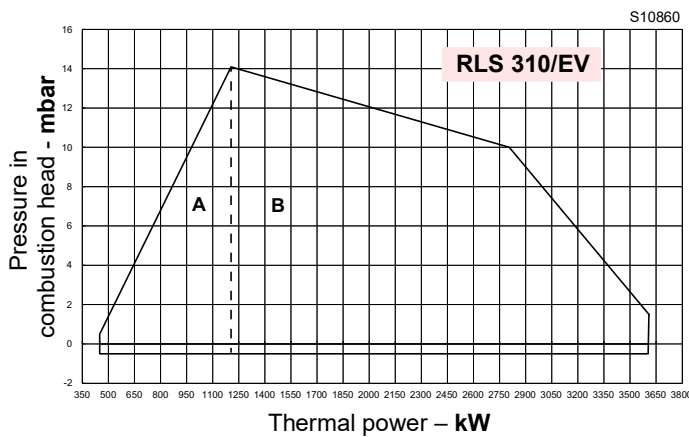

Fig. 2

3.8 Test boiler

The burner/boiler combination does not pose any problems if the boiler is EC approved and its combustion chamber dimensions are similar to those indicated in the diagram (Fig. 3).

If the burner must be combined with a boiler that has not been EC approved and/or its combustion chamber dimensions are clearly smaller than those indicated in the diagram, consult the manufacturer.

The firing rates were set in relation to special test boilers, according to EN 676 regulations.

In Fig. 3 you can see the diameter and length of the test combustion chamber.

Example:
Output 3000 kW - diameter 100 cm - length 3.5 m

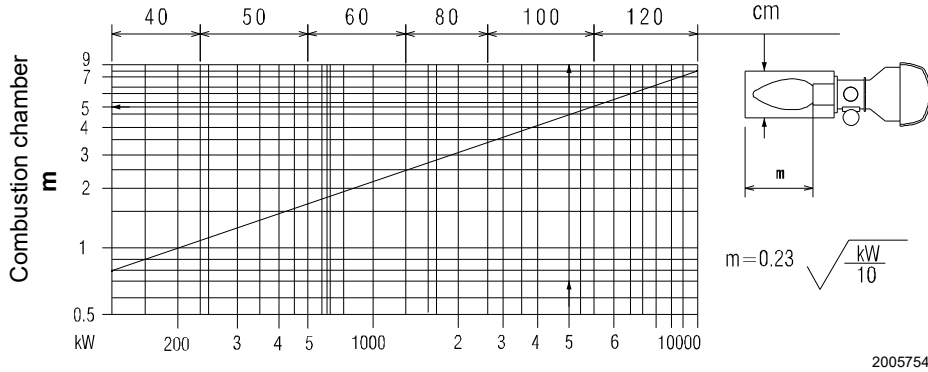

20057548

Fig. 3

3.9 Burner equipment

- Gasket for gas train adaptor. No. 1
- Adaptor for gas train. No. 1
- Screws for fixing the gas train adaptor: M 16 x 70 No. 4
- Thermal insulation screen No. 1
- M 18 x 60 screws to secure the burner flange to the boiler No. 4
- Flexible hoses No. 2
- Hydraulic fittings. No. 2
- Cable grommets kit for optional electrical wiring input. No. 1
- M16 nuts to fix the gas elbow to the pipe coupling No. 4
- Stud bolts M16X70 to fix the gas elbow to the pipe coupling No. 4
- Gas nozzles (only for RLS 310 model) No. 8
- Spare parts list. No. 1
- Instructions. No. 1



It is recommended to tighten the screws of the gas flange with a tightening torque of:

- 20 Nm ±10% with No. 8 M16;
- 40 Nm ±10% with No. 4 M16.

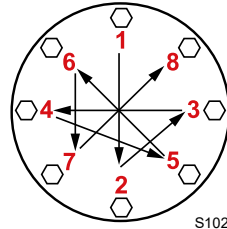

Tighten the nuts gradually (first to 30%, then to 60% up to 100%) according to the cross pattern shown in the figure.

3.10 Burner description

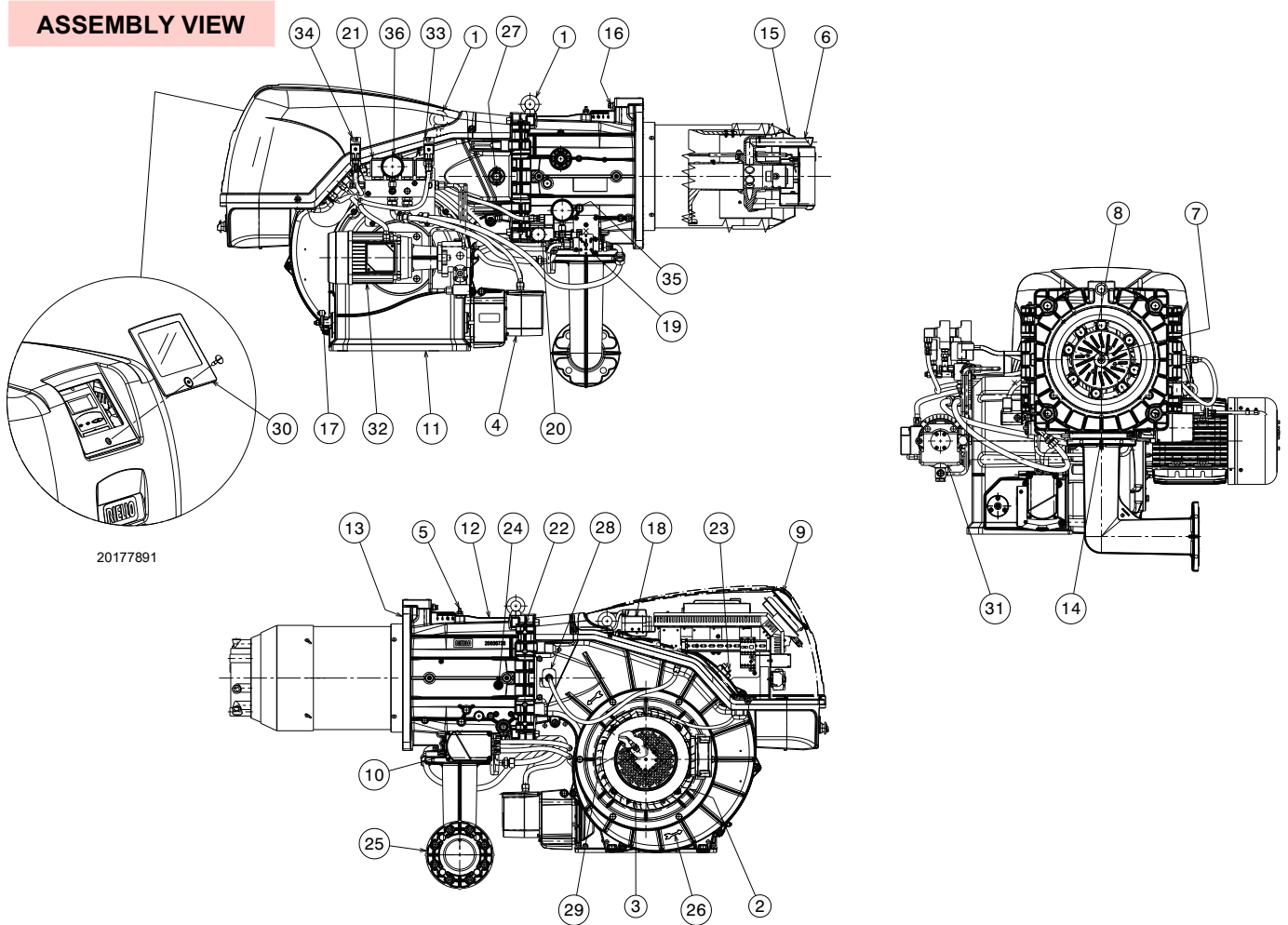

Fig. 4

- | | |
|--|-----------------------------------|
| 1 Lifting rings | 31 Pump |
| 2 Fan | 32 Pump motor |
| 3 Fan motor | 33 Minimum oil pressure switch |
| 4 Air damper servomotor | 34 Maximum oil pressure switch |
| 5 Combustion head gas pressure test point | 35 Nozzle return pressure gauge |
| 6 Combustion head | 36 Nozzle delivery pressure gauge |
| 7 Ignition electrodes | |
| 8 Flame stability disk | |
| 9 Electrical panel casing | |
| 10 Gas butterfly valve and oil modulator servomotor | |
| 11 Fan air inlet | |
| 12 Pipe coupling | |
| 13 Gasket for boiler fixing | |
| 14 Gas butterfly valve | |
| 15 Shutter | |
| 16 Combustion head movement screw | |
| 17 Lever for controlling the dampers with graduated scale | |
| 18 Air pressure switch | |
| 19 Oil modulator | |
| 20 Maximum gas pressure switch with pressure test point | |
| 21 Valve group | |
| 22 Hinge for opening the burner | |
| 23 Pressure test point for air pressure switch “+” | |
| 24 Combustion head air pressure test point | |
| 25 Gas train adapter | |
| 26 Indication for checking the rotation direction of the purging motor | |
| 27 Flame inspection window | |
| 28 Flame sensor | |
| 29 Motor revolution sensor | |
| 30 Transparent protection | |



The burner can be opened to the right or to the left without links to the fuel supply side.



To open the burner see section “Access to head internal part” on page 22.

3.11 Electrical panel description

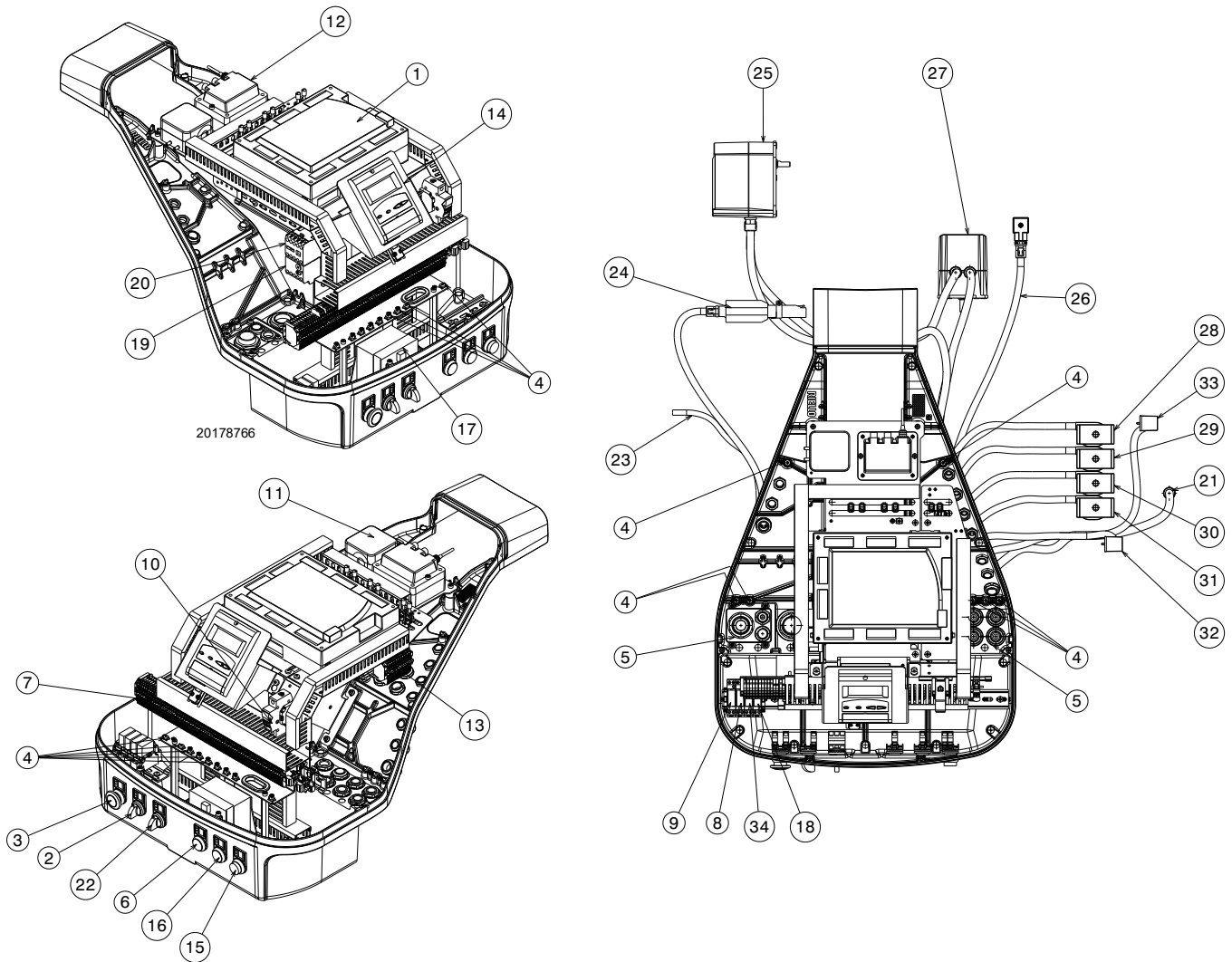

Fig. 5

- | | |
|---|---|
| <ul style="list-style-type: none"> 1 Electronic cam 2 ON/OFF selector 3 Emergency button 4 Earth terminal 5 Supply cables and external connections passage.
See section "Electrical wiring" on page 31 6 "POWER ON" light signalling 7 Main terminal supply board 8 Relay with clean contacts for signalling the burner is in lock-out 9 Relay with clean contacts for signalling the burner is in GAS operation 10 Auxiliary circuits fuse 11 Air pressure switch 12 Ignition transformer 13 Valve group terminal board 14 Operator panel with LCD display 15 Light signalling burner lockout and reset button 16 "OVERLOAD FAN MOTOR" light signalling 17 Electronic cam transformer 18 Relay with clean contacts for signalling the burner is in operation 19 Thermal relay of pump motor (with RESET button) 20 Pump motor contactor 21 Sheath for pump motor cables 22 Change of fuel selector 23 Sheath for motor revolution sensor 24 Flame sensor | <ul style="list-style-type: none"> 25 Fuel servomotor 26 Sheath for maximum gas pressure switch 27 Air servomotor 28 Safety valve sheath (VS1) 29 Return line valve sheath (VR) 30 Working valve sheath (VF) 31 Safety valve sheath (VS) 32 Sheath for minimum oil pressure switch 33 Sheath for maximum oil pressure switch 34 Relay with clean contacts for signalling the inverter is in lockout |
|---|---|

3.12 Flame control (LMV52...)

Warnings



To avoid accidents, material or environmental damage, observe the following instructions!

The LMV52 flame control... is a safety device! Avoid opening or modifying it, or forcing its operation. Riello S.p.A. cannot assume any responsibility for damage resulting from unauthorised interventions!

Risk of explosion!

An incorrect configuration can provoke fuel overcharging, with the consequential risk of explosion! Operators must be aware that incorrect settings made on the AZL5... display and operating unit and incorrect settings of the fuel and / or air actuator positions can lead to dangerous burner operating conditions.

- All interventions (assembly and installation operations, assistance, etc.) must be carried out by qualified personnel.
- Before modifying the wiring in the LMV52 flame control connection area, fully disconnect the system from the power supply (omnipolar separation). Check the system is not powered and cannot be accidentally reconnected. Failure to do this will lead to the risk of electrocution.
- Protection against electrocution from the LMV5... flame control and all connected electric components is obtained with correct assembly.
- Before any intervention (assembly and installation operations, assistance, etc.), ensure the wiring is in order and that the parameters are correctly set, then make the safety checks.
- Falls and collisions can negatively affect the safety functions. In this case, the flame control must not be operated, even if it displays no evident damage.
- In programming mode, the position check of actuators and VSD (checking electronic fuel / air ratio control) is different from the check during automatic operation. As for automatic operation, the actuators are guided together to the positions requested and, if an actuator does not reach the position requested, adjustments are made until the position is actually reached. However, in contrast to automatic operation, there are no time limits to these corrective actions. The other actuators maintain their positions until all actuators have reached the positions currently required. This is absolutely important to set the fuel / air ratio control system. During the time the fuel / air ratio curves are being programmed, the person making the plant settings must continuously monitor the quality of the combustion process (e.g. by means of a flue gas analyser). Also, if combustion levels are poor, or in the event of dangerous situations, the commissioning engineer must take appropriate action (e.g. switching off manually).

To ensure the safety and reliability of the LMV5... system, the following instructions must also be followed:

- avoid conditions that can favour the development of condensate and humidity. Otherwise, before switching on again, make sure that the entire flame control is perfectly dry!
- Static charges must be avoided since they can damage the flame control's electronic components when touched.



D9301

Fig. 6

Mechanical structure

The LMV5... flame control is a system to check the burners, based on a microprocessor and equipped with components to adjust and monitor medium and large capacity forced draught burners.

The base flame control of the LMV5... system incorporates the following components:

- Burner adjustment device with system for checking the seal of the gas valves
- Electronic fuel/air ratio monitoring device with a maximum of 6 (LMV52...) actuators
- Optional PID temperature / pressure controller (load controller)
- Optional VSD module Mechanical design.

Electrical connection of flame sensor

It is important for signal transmission to be almost totally free of any disturbances or loss:

- always separate the detector cables from the other cables:

– Line capacitance reduces the magnitude of the flame signal.
– Use a separate cable.

- Respect the allowed cable lengths.

Technical data

LMV52... flame control	base	Mains voltage	AC 230V -15% / +10%
		Mains frequency	50 / 60 Hz ±6 %
		Power absorption	< 30W (normal)
		Safety class	I, with components in compliance with II and III, according to DIN EN 60730-1
Load on 'input' terminals		F1 unit fuse (internal)	6.3 AT
		Main fuse of perm. network (external)	Max. 16 AT
		Undervoltage	
		• Safety switch-off from operating position to mains voltage	< AC 186 V
		• Restart when mains voltage picks up	> AC 188 V
		Oil pump / magnetic clutch (nominal voltage)	
Load on 'output' terminals		• Nominal current	2A
		• Power factor	cosφ > 0.4
		Air pressure switch test valve (nominal voltage)	
		• Nominal current	0.5A
		• Power factor	cosφ > 0.4
		Total load on the contacts:	
		• Mains voltage	AC 230 V -15 % / +10 %
		• Total unit input current (safety circuit) load on contacts due to:	Max. 5 A
		- Fan motor contactor	
		- Ignition transformer	
		- Valve	
		- Oil pump / magnetic clutch	
	Single contact loading:		
	Fan motor contactor (nominal voltage)		
	• Nominal current	1A	
	• Power factor	cosφ > 0.4	
	Alarm output (nominal voltage)		
	• Nominal current	1A	
	• Power factor	cosφ > 0.4	
	Ignition transformer (nominal voltage)		
	• Nominal current	2A	
	• Power factor	cosφ > 0.2	
	Fuel gas valve (nominal voltage)		
	• Nominal current	2A	
	• Power factor	cosφ > 0.4	
	Fuel oil valve (nominal voltage)		
	• Nominal current	1A	
	• Power factor	cosφ > 0.4	
Cable lengths	Main line		Max. 100 m (100 pF/m)
Environmental conditions	Operation		DIN EN 60721-3-3
	Climatic conditions		Class 3K3
	Mechanical conditions		Class 3M3
	Temperature range		-20...+60°C
	Humidity		< 95% RH

Tab. F



Condensation, the formation of ice and the entry of water are prohibited!

3.13 Servomotor

Warnings



WARNING

To avoid accidents, material or environmental damage, observe the following instructions!

Avoid opening, modifying or forcing the actuators.

- All interventions (assembly and installation operations, assistance, etc.) must be carried out by qualified personnel.
- Before modifying the wiring in the SQM4... system connection area, fully disconnect the burner control device from the power supply (omnipolar separation).
- To avoid the risk of electrocution, protect the connection terminals in a suitable manner and correctly fix the cover.
- Check the wiring is in order.
- Falls and collisions can negatively affect the safety functions. In this case, the unit must not be operated, even if it displays no evident damage.

Assembly notes

- Check the relevant national safety standards are respected.
- The connection between the actuator command shaft and the control element must be rigid, without any mechanical play.
- To avoid an excessive load on the bearings due to rigid hubs, the use of compensation clutches without any mechanical play is recommended (e.g. metal bellows-type clutches).

Installation notes

- Arrange the H.V. ignition cables separately, as far as possible from the flame control and the other cables.
- To avoid the risk of electrocution, make sure that the 230V AC section of the SQM4... unit is fully separated from the functional low-voltage section.
- The static torque is reduced when the electrical supply of the actuator is switched off.
- The housing cover may only be removed for short periods of time for wiring or when making the addressing. In similar cases, make sure that dust or dirt does not penetrate inside the actuator.
- The actuator comprises a PCB with ESD-sensitive components.
- The top side of the board carries a cover which affords protection against direct contact. This protective cover must not be removed! The underside side of the board must not be touched.



WARNING

During the maintenance or replacement of the actuators, be careful not to invert the connectors.

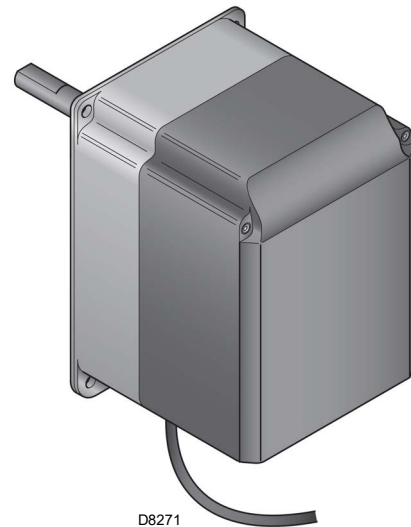

Fig. 7

Technical data

Operating voltage	AC 2 x 12V via bus cable from the base unit or via a separate transformer
Safety class	extra low-voltage with safe isolation from mains voltage
Power absorption	
– SQM45...	9...15 VA
– SQM48...	26...34 VA
Degree of protection	to EN 60 529, IP 54, provided adequate cable entries are used
Cable connection	RAST3,5 connectors
Rotation direction	- Anticlockwise (standard) - Clockwise (inverted rotation)
Nominal torque (max)	
– SQM45...	3 Nm
– SQM48...	20 Nm
Holding torque (max)	
– SQM45...	1.5 Nm
– SQM48...	20 Nm
Running time (min.) for 90°	
– SQM45...	10 s.
– SQM48...	30 s.
Weight	
– SQM45...	1 kg approx.
– SQM48...	1.6 kg approx.
Environmental conditions:	
Operation	DIN EN 60 721-3-3
Climatic conditions	Class 3K3
Mechanical conditions	Class 3M3
Temperature range	-20...+60°C
Humidity	< 95% RH

Tab. G

3.14 PLL52... module (optional)

Warnings



To avoid accidents, material or environmental damage, observe the following instructions!

Avoid opening, modifying or forcing the device.

- All interventions (assembly and installation operations, assistance, etc.) must be carried out by qualified personnel.
- Falls and collisions can negatively affect the safety functions. In this case, the unit must not be operated, even if it displays no evident damage.

Assembly notes

- Check the relevant national safety standards are respected.

3.14.1 Terminal ratings, cable lengths and cross-sectional areas

Cable lengths / cross-sectional areas	
Electrical connection "X89"	Screw terminals up to max. 2.5 mm ²
Cable lengths	≤ 10 m fino a QGO20...
Cross-sectional areas	Refer to description of QGO20...
Analog inputs	
Air temperature detector	Pt1000 / LG-Ni1000
Flue gas temperature	Pt1000 / LG-Ni1000
QGO20...	Refer to data sheet N7842
Interface	Communication bus for LMV52...

Tab. H



Fig. 8

Technical data

Model	PLL52...
Mains voltage "X89-01"	AC 230 V -15%/10%
Safety class	I class with parts according to II class (DIN EN 60730-1)
Mains frequency	50 / 60 Hz ±6 %
Power consumption	Ca. 4 VA
Degree protection	IP54, housing closed
Transformer AGG5.220	
- Primary side	AC 230V
- Secondary side	AC 12 V (3x)

Environmental conditions:

Storage	DIN EN 60721-3-1
Climatic conditions:	Class 1K3
Mechanical conditions:	Class 1M2
Temperature range:	-20...+60 °C
Humidity:	<95% r.h.
Transport	DIN EN 60721-3-2
Climatic conditions:	Class 2K2
Mechanical conditions:	Class 2M2
Temperature range:	-25...+70 °C
Humidity:	<95% r.h.
Operation	DIN EN 60 721-3-1
Climatic conditions:	Class 3K5
Mechanical conditions:	Class 3M2
Temperature range:	-20...+60 °C
Humidity:	< 95% r.h.

Tab. I

NOTE:

For detailed information, refer to the specific manual of PLL52 module.



Condensation, formation of ice and the entrance of water are not permitted!

3.15 Oxygen sensor QGO20 ... (optional)

Warnings



WARNING

To avoid accidents, material or environmental damage, observe the following instructions!

Avoid opening, modifying or forcing the oxygen sensor.

- All interventions (assembly and installation operations, assistance, etc.) must be carried out by qualified personnel.
- Before modifying the wiring in the sensor connection area, fully disconnect the burner control device from the power supply (omnipolar separation).
- Ensure that the sensor cannot be inadvertently switched on again and check this by making a voltage test.
- To avoid the risk of electrocution, protect the connection terminals in a suitable manner and correctly fix the cover.
- During operation, the flange of the sensor connection must be kept closed; all screws must be tightened securely.
- Check the wiring is in order.
- Falls and collisions can negatively affect the safety functions. In this case, the unit must not be operated, even if it displays no evident damage.
- Ensure that the device does not get into contact with explosive or inflammable gases.
- There is a risk of burning since the measuring cell works at an operating temperature of 700 °C and other accessible parts can get very hot too (> 60 °C).
- To prevent injury caused by the hot immersion tube, remove the device only after the equipment has cooled down.
- Make certain that the sensor's inlet and outlet are always kept free from dirt.
- Before cleaning the inlet and outlet, allow the sensor to cool down for at least 1 hour.
- Mount the sensor such that the connecting part (head to flange) is free so that the exchange of air is ensured. Otherwise, measurements might get distorted, possibly leading to dangerous situations.
- Ensure that there are no chemicals, such as solvent vapors, near the sensor.

Installation notes

- The flue gas flow passing the measuring cell must be homogeneous, with no or only little turbulence. When mounted too close to air dampers or pipe bends, faulty measurements can occur.
- A number of faults can distort the measurements (this can lead to dangerous situations in connection with oxygen trim control):
 - If the stack is not tight, false air can join the flue gases.
 - In that case, the residual oxygen content indicated by the sensor is higher than it actually is.
 - If the flue gas velocity is low, the sensor's response is slower, since the flue gases take more time to pass the measuring cell. In that case, it is recommended to mount the sensor in an inclined position (refer to the manual).
 - The greater the sensor's distance from the flame, the longer the dead time.

S9895

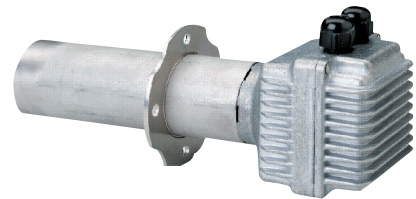

Fig. 9

NOTE:

For further explanations about the wiring connetions, please refer to the manual supplied with the accessory code 20045187.



WARNING

Condensation, formation of ice and the entrance of water are not permitted!

3.15.1 Technical data QGO20

Operating voltage of measuring cell's:	
– QGO20.000D27	AC 230 V ±15 %
– QGO20.000D17	AC 120 V ±15 % (only with LMV52 ... with PLL52...)
Mains frequency:	50...60 Hz ±6 %
Power consumption:	Max. 90 W, typical value 35 W (controlled)
Permissible mounting position:	Refer to mounting Instructions M7842
Degree of protection:	IP40, to be ensured through installation
Weight (net):	approx. 0.9 kg
Signal lines	
– Shielded 6-wires cable	Twisted pairs
– Shielding connected to terminal GND of the PL52...	
Wire diameter	LiFYCY3x2x0,2 o LYCY3x2x0,2
Measuring system	Zirconium dioxide measuring cell as an oxygen ion conductor
Permissible flue gas velocity (only with AGO20...)	1...10 m/s
Fuel type	Fuel oil EL or Natural gas H
Measuring range	0.2...20.9 % O ₂
Permissible cable length	Max. 100 m
Wire diameter	<10 m
Power supply lines (Net cable)	Min. 1 mm ²
– Cable diameter	QGO20.000D27: e.g. NYM 3 x 1,5
– Cable type	QGO20.000D17: UL AWM Style 1015/MTW or CSA-AWM/TEW
Required operating temperature of measuring cell	700 °C ±50 °C
Environmental conditions	
Storage	DIN EN 60721-3-1
Climatic conditions:	Class 1K3
Mechanical conditions:	Class 1M2
Temperature range:	-20...+60 °C
Humidity:	<95% r.h.
Transport	DIN EN 60721-3-2
Climatic conditions:	Class 2K2
Mechanical conditions:	Class 2M2
Temperature range:	-25...+70 °C
Humidity:	<95% r.h.
Operation	DIN EN 60721-3-3
Climatic conditions:	Class 3K5
Mechanical conditions:	Class 3M2
Temperature range:	
– Flange	Max. 250 °C
– Connecting head	Max. 70 °C
– Flue gases	≤300 °C
Humidity:	<95% r.h.
Installation altitude:	Max. 2000 m a.s.l.

Tab. J

3.16 Calibration of the thermal relay

The thermal relay serves to avoid damage to the motor due to an excessive absorption increase or if a phase is missing.

For calibration 2), see the table in the wiring diagram.

To reset, in case of an intervention of the thermal relay, press the "RESET" button 1)(Fig. 10). The red "TEST" button 3) opens the NC (95-96) contact and stops the motor.



CAUTION

The automatic reset (Position "A" button 1) can be dangerous. This operation is not anticipated in the burner's operation, leave it always on "H". **Therefore do not position the "RESET" button 1) on "A".**

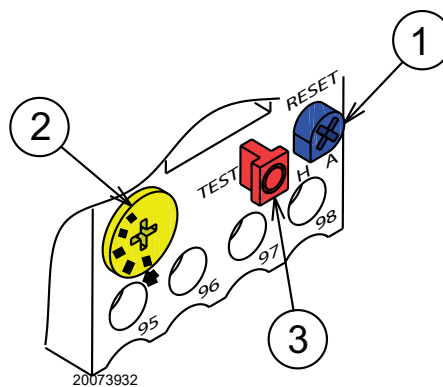

Fig. 10

4 Installation

4.1 Notes on safety for the installation

After carefully cleaning all around the area where the burner is to be installed, and arranging for the environment to be illuminated correctly, proceed with the installation operations.



All the installation, maintenance and disassembly operations must be carried out with the electricity supply disconnected.



The installation of the burner must be carried out by qualified personnel, as indicated in this manual and in compliance with the standards and regulations of the laws in force.



Combustion air inside the boiler must be free from hazardous mixes (e.g.: chloride, fluoride, halogen); if present, it is highly recommended to carry out cleaning and maintenance more frequently.

4.2 Handling

The burner packaging includes a wooden platform, it is therefore possible to move the burner (still packaged) with a transpallet truck or fork lift truck.



The handling operations for the burner can be highly dangerous if not carried out with the greatest attention: keep any unauthorised people at a distance; check the integrity and suitability of the available means of handling. Check also that the area in which you are working is empty and that there is an adequate escape area (i.e. a free, safe area to which you can quickly move if the burner should fall). When handling, keep the load at not more than 20-25 cm from the ground.



After positioning the burner near the installation point, correctly dispose of all residual packaging, separating the various types of material.



Before proceeding with the installation operations, carefully clean all around the area where the burner will be installed.



Release the burner from the wooden platform by removing the bolts/nuts/screws that secure the burner to the platform. Handle the burner following the safety standards and regulations of the laws in force and using the eyebolts supplied as equipment.

4.3 Preliminary checks

Checking the consignment



After removing all the packaging, check the integrity of the contents. In the event of doubt, do not use the burner; contact the supplier.



The packaging elements (wooden cage or cardboard box, nails, clips, plastic bags, etc.) must not be abandoned as they are potential sources of danger and pollution; but should be collected and disposed of in the appropriate places.

		A		B	
		D		C	
		E		F	
GAS-KAASU	<input checked="" type="checkbox"/> FAM.2	G		H	
GAZ-AEPIO	<input type="checkbox"/> FAM.3	G		H	
		I			
		L			
				CE	
		[Barcode]			

20206732

Fig. 11

Checking the characteristics of the burner

- Check the identification label of the burner, showing:
- the model (A)(Fig. 11) and type of burner (B);
 - the year of manufacture, in cryptographic form (C);
 - the serial number (D);
 - the data for electrical supply and the protection level (E);
 - the absorbed electrical power (F);
 - the types of gas used and the relative supply pressures (G);
 - the data of the burner's minimum and maximum output possibilities (H) (see Firing rate).
- Warning.** The burner output must be within the boiler's firing rate;
- the category of the appliance/countries of destination (I).



A burner label, or any other component, that has been tampered with, removed or is missing, prevents the definite identification of the burner and makes any installation or maintenance work difficult.

4.4 Operating position



- The burner is designed to operate only in positions 1, 2, 3 and 4 (Fig. 12).
- Installation 1 is preferable, as it is the only one that allows the maintenance operations as described in this manual.
- Installations 2, 3 and 4 permit operation but make maintenance and inspection of the combustion head more difficult.



- Any other position could compromise the correct operation of the appliance.
- Installation 5 is prohibited for safety reasons.

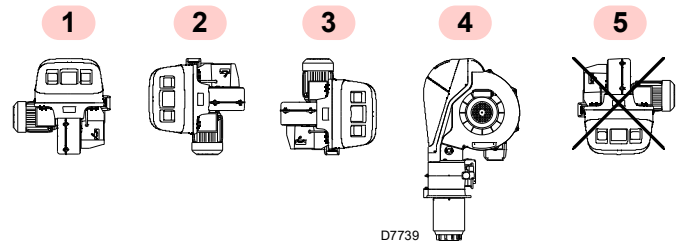

Fig. 12

4.5 Preparing the boiler

4.5.1 Boring the boiler plate

Drill the combustion chamber locking plate as shown in Fig. 13. The position of the threaded holes can be marked using the thermal screen supplied with the burner.

4.5.2 Blast tube length

The length of the blast tube must be selected according to the indications provided by the manufacturer of the boiler, and in any case it must be greater than the thickness of the boiler door complete with its fettling.

For boilers with front flue passes 1)(Fig. 14) or flame inversion chamber, a protection in refractory material 5) must be inserted between the boiler fettling 2) and the blast tube 4).

The refractory can have a conical shape (minimum 60°).

This protective fettling must not compromise the extraction of the blast tube.

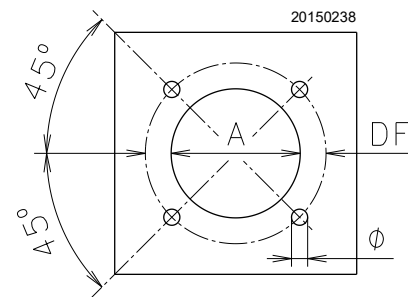

Fig. 13

mm	A	DF	Ø
RLS 310	335	452	M18
RLS 410	335	452	M18
RLS 510	335	452	M18
RLS 610	350	452	M18

Tab. K

4.6 Securing the burner to the boiler



Prepare a suitable lifting system using the rings 3)(Fig. 14), after removing the fixing screws 7) of the casing 8).

- Fit the heat insulation supplied onto the blast tube 4)(Fig. 14).
- Fit the entire burner onto the boiler hole prepared previously (Fig. 13), and fasten with the screws supplied.



The seal between burner and boiler must be airtight.

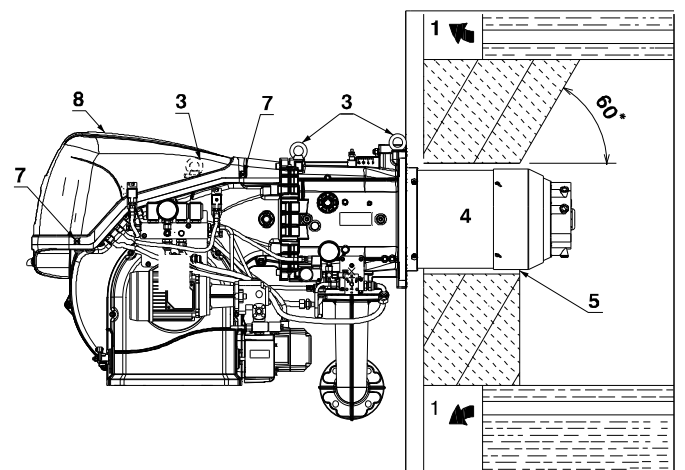

Fig. 14

4.7 Access to head internal part

The burner leaves the factory set for opening to the right, therefore maintaining the pin 1)(Fig. 15) in its housing.

To open the burner towards the right, proceed as follows:

- A** remove the screws 2);
- B** open the burner to a maximum of 100-150 mm by rotating around the hinge and release the cables of the electrodes 5);
- C** fully open the burner as in Fig. 15;
- D** disconnect the light oil pipes by unscrewing the two swivel fittings 8);
- E** undo the screw 4) with pressure test point;
- F** release the head by lifting it from its housing 3), then take out the combustion head.



WARNING

To open the burner from the opposite side, before removing the pin 1)(Fig. 15), make sure that the 4 screws 2) are tight. Then shift the pin 1) to the opposite side, only then is it possible to remove the screws 2). Disconnect the socket of the maximum gas pressure switch, then proceed as described above at point **C**).

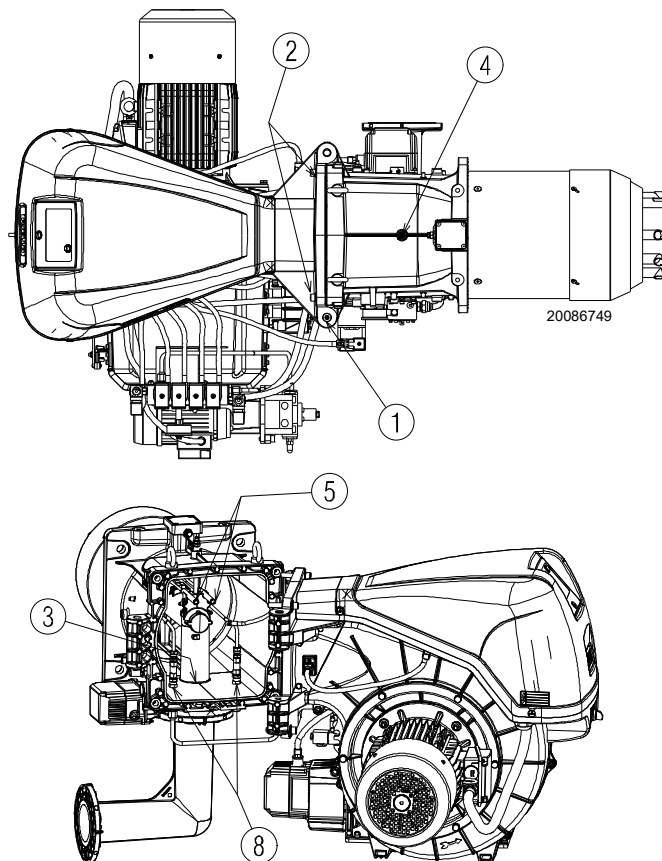

Fig. 15

4.8 Position of the electrodes and central gas nozzles



WARNING

Check that the electrodes are positioned correctly, as in Fig. 16, complying with the dimensions indicated.

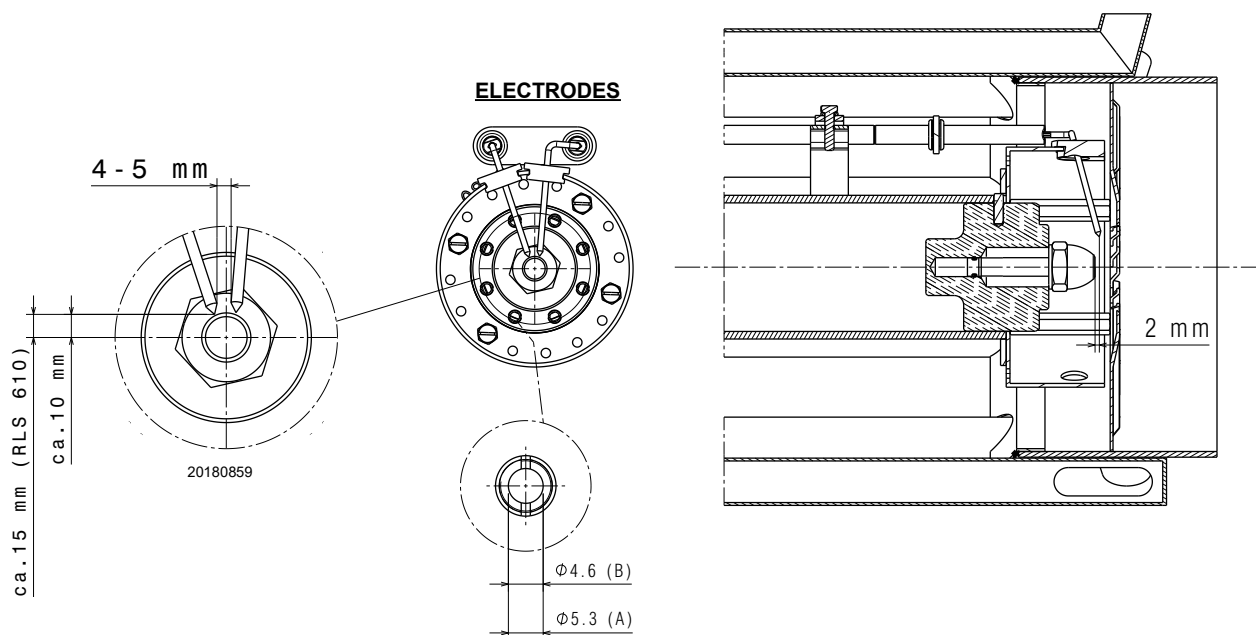

Fig. 16

4.9 Gas butterfly valve

If necessary, replace the gas butterfly valve. The correct position is shown in Fig. 18.

4.10 Combustion head adjustment

Rotate the screw 1)(Fig. 19) until the notch you have found corresponds with the front surface of the screw itself.

The combustion head is opened by turning the screw 1) anti-clockwise.

The combustion head is closed by turning the screw 1) clockwise.



The burner leaves the factory with the combustion head adjusted to notch 0 (Fig. 19).

This adjustment allows you to secure the moving parts when the burner is being transported.

Before starting the burner, carry out the adjustments for the output required and which is indicated in the diagram (Fig. 17).

NOTE:

Depending on the specific application, the adjustment can be modified.

↓ No. of notches (air = gas)

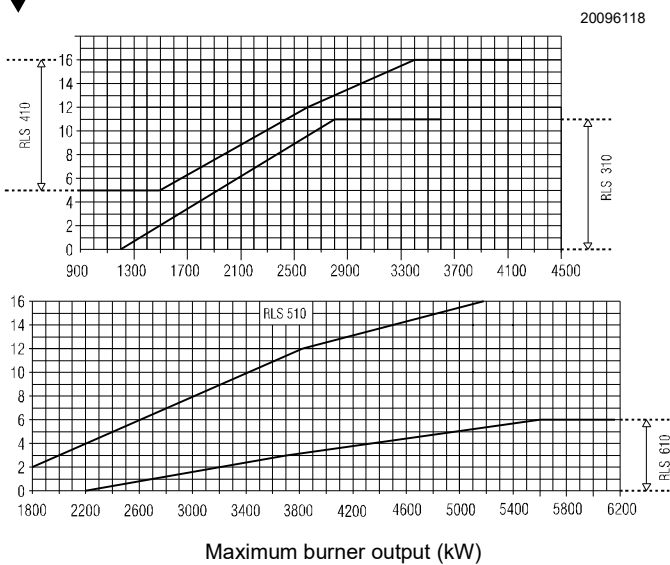

Fig. 17



The combustion head can be adjusted within the following fields:

- RLS 310: 0 - 11;**
- RLS 410: 5 - 16;**
- RLS 510: 2 - 16;**
- RLS 610: 0 - 6.**

No adjustment can be made outside this interval.

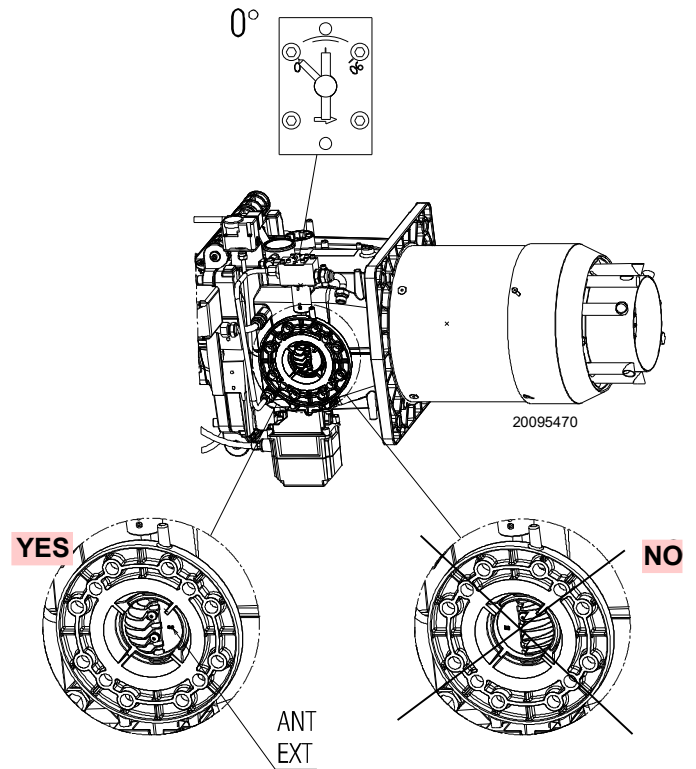

Fig. 18

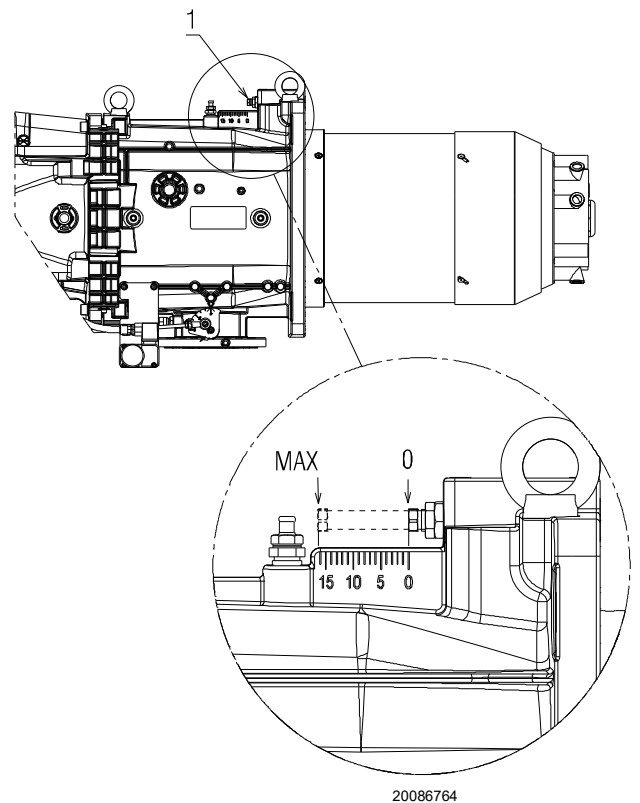

Fig. 19

4.11 Nozzle installation

The burner complies with the emission requirements of the EN 267 standard.

In order to guarantee that emissions do not vary, recommended and/or alternative nozzles specified by the Manufacturer in the Instruction and warning booklet should be used.



It is advisable to replace nozzles every year during regular maintenance operations.

The use of nozzles other than those specified by the Manufacturer and inadequate regular maintenance may result into emission limits non-conforming to the values set forth by the regulations in force, and in extremely serious cases, into potential hazards to people and objects.



The manufacturing company shall not be liable for any such damage arising from non-observance of the requirements contained in this manual.

Fit the nozzle with a pipe wrench (24 mm), passing through the central opening of the flame stability disc (Fig. 20).

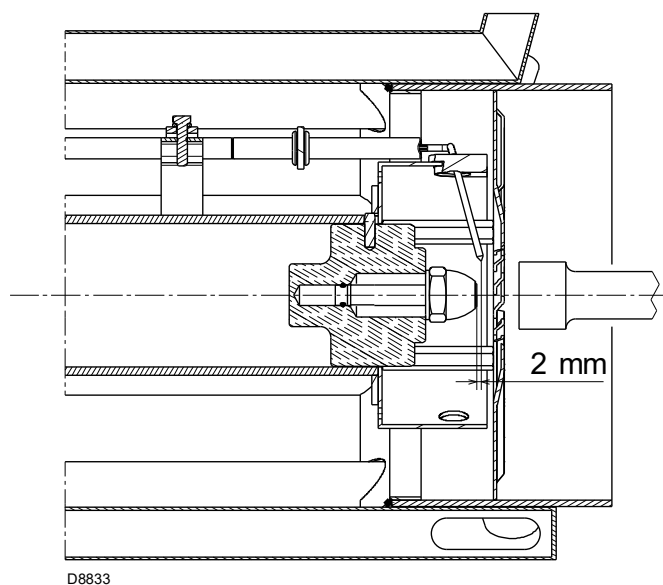

Fig. 20

Fit the nozzles on the nozzle holder without the fuel interception rod.

To calibrate the flow rate range within which the nozzle should operate, adjust the fuel pressure on the nozzle return line, according to and Tab. L.



- Do not use any sealing products such as: gaskets, sealing compound, or tape.
- Be careful to avoid damaging the nozzle sealing seat.
- The nozzle must be screwed into place tightly but not to the maximum torque value provided by the wrench.

4.11.1 Recommended nozzle

- Fluidics type N2 45°

Alternatively:

- Bergonzo type B5 45° SA

Complete range of nozzles:

- **Bergonzo type B5 45°**
150 - 200 - 225 - 250 - 275 - 300 - 325 - 350 - 375 - 400 - 425 - 450 - 475 - 500 - 525 - 550 - 575 - 600.
- **Fluidics type N1 45°**
160 - 180 - 200 - 225 - 250 - 275 - 300 - 330 - 360 - 400 - 450 - 500 - 550 - 600.
- **Fluidics type N2 45°**
160 - 180 - 200 - 225 - 250 - 275 - 300 - 330 - 360 - 400 - 450 - 500 - 550 - 600.

	kg/h	Pressione mandata bar	Pressione ritorno bar	kg/h	kW
RLS 310 - 410	150	21	13	51	600
		21	19	106	1250
	200	22	8.5	67	800
		22	17.5	150	1800
	300	20	7	100	1200
		20	17.5	257	3000
	375	20	6.5	148	1750
		20	15.5	305	3600
425	20	7.5	68	1950	
	20	17	344	4100	
RLS 510	250	24	9	94	1120
		25	15.5	210	2500
	360	24	7.5	116	1380
		25	14	260	3090
	400	24	8.5	153	1820
		25	15	355	4220
	450	24	8	164	1950
		25.5	16	425	5050
RLS 610	300	20	9.5	125	1500
		20	14	250	3000
	450	20	8	134	1600
		20	14	380	4550
	575	20	9.5	193	2300
		20	17	510	6070

Tab. L

4.12 Light oil supply

4.12.1 Double-pipe circuit

The burner is equipped with a self-priming pump which is capable of feeding itself within the limits listed in the table at the side.

Tank higher than burner A (Fig. 21)

Distance P must not exceed 10 meters in order to avoid straining the pump's seal; distance V must not exceed 4 meters in order to allow the self-priming of the pump even when the tank is almost empty.

Tank lower than burner B (Fig. 21)

Pump depression values higher than 0.45 bar (35 cm Hg) must not be exceeded. because at higher levels gas is released from the fuel, the pump starts making noise and its working life-span decreases.

It is good practice to ensure that the return and suction lines enter the burner from the same height; in this way it will be less probable that the suction line fails to prime or stops priming.

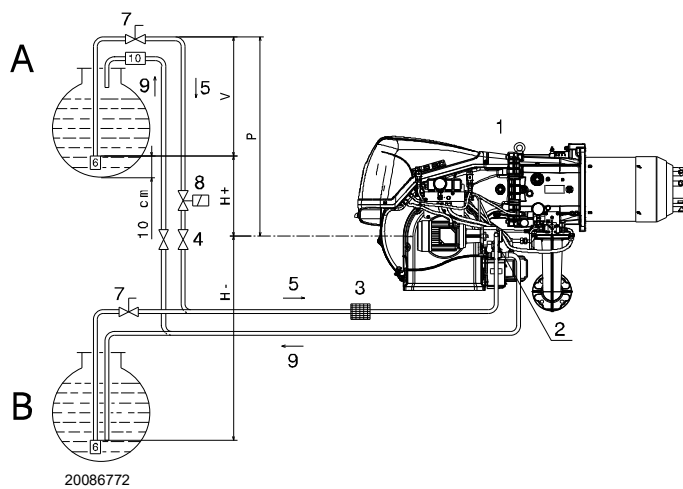

Fig. 21

Key (Fig. 21)

- H = Pump/Foot valve height difference
- L = Piping length
- Ø = Inside pipe diameter
- 1 = Burner
- 2 = Pump
- 3 = Filter
- 4 = Manual on/off valve
- 5 = Suction line
- 6 = Foot valve
- 7 = Quick closing manual valve with remote control (Italy only)
- 8 = On/off solenoid valve (Italy only). See electrical diagram. Connections to be carried out by the installer (SVOIL).
- 9 = Return line
- 10 = Check valve (only Italy)

4.12.2 The loop circuit

A loop circuit consists of a loop of piping departing from and returning to the tank with an auxiliary pump that circulates the fuel under pressure.

A branch connection from the loop feeds the burner.

This circuit is extremely useful whenever the burner pump does not succeed in self-priming because the tank distance and/or height difference are higher than the values listed in the table.

H (m)	L (m)			
	Ø (mm)			
	10	12	14	16
4	14	30	55	95
3.5	13	28	52	89
3	12	26	48	82
2.5	11	24	44	76
2	10	22	41	70
1.5	9	20	37	63
1	8	18	33	57
0.5	7	16	29	51
0	6	14	26	44
-0.5	5	12	22	38
-1	4	10	18	32
-1.5	3	8	15	25
-2		6	11	19
-2.5		4	7	13
-3			4	7

4.12.3 Hydraulic connections

The pumps are equipped with a by-pass that connects return line with suction line.

They are installed on the burner with the by-pass closed by screw 6)(Fig. 22 on page 26).

It is therefore necessary to connect both hoses to the pump.

The pump will break down immediately if it is run with the return line closed and the by-pass screw inserted.

Remove the plugs from the suction and return connections of the pump.

Insert the hose connections with the supplied seals into the connections and screw them down.

Take care that the hoses are not stretched or twisted during installation.

Place the pipes so that they are not crushed or are in contact with hot parts of the boiler and so it is possible to open the burner.

Connect, finally, the other end of the flexible hoses to the suction and return lines using nipples supplied with the equipment.

4.12.4 Priming pump



WARNING

Before starting the burner, make sure that the tank return line is not clogged.

Obstructions in the line could cause the sealing organ located on the pump shaft to break.

- In order for the pump (Fig. 22) to self-prime, it is vital that the screw 4) of the pump be loosened to vent the air contained in the suction line.
- Start the burner by closing the remote controls. As soon as the burner starts, check the direction of rotation of the fan blade.
- The pump can be considered to be primed when the light oil starts coming out of the screw 4). Close the burner and undo the screws 4).

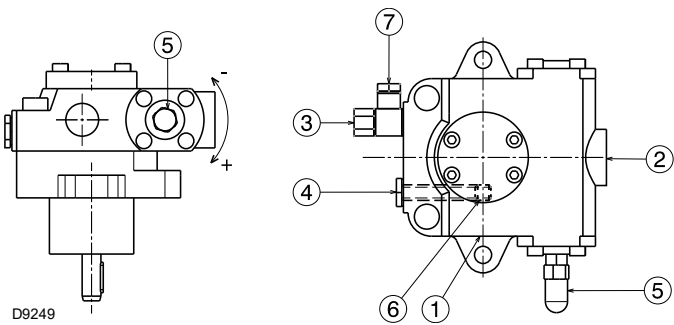

Fig. 22

Key (Fig. 22)

- | | |
|------------------------------|--------|
| 1 Suction line | G 1/2" |
| 2 Return line | G 1/2" |
| 3 Pressure switch connection | G 1/4" |
| 4 Vacuumeter connection | G 1/4" |
| 5 Pressure adjuster | |
| 6 By-pass screws | |
| 7 Gauge connection | G 1/4" |

MODELS		RLS 310	RLS 410	RLS 510 RLS 610
		TA 3	TA 4	TA 5
Min. delivery rate at 16.5 bar pressure	Kg/h	700	930	1270
Pressure range in outlet line	bar	7 - 40		7 - 30
Max depression in suction line	bar	0,45		0,45
Viscosity range	cSt	2 - 75		2 - 75
Maximum oil temperature	°C	150		150
Max pressure in suction and return lines	bar	5		5
Pressure calibration in factory	bar	22 - 20		22 - 20

Tab. M

The time required for this operation depends upon the diameter and length of the suction tubing.

If the pump fails to prime at first start-up and the burner locks out, wait approx. 15 seconds, reset the burner, and then repeat the start-up operation.

And so on. After 5 or 6 starting operations allow 2 or 3 minutes for the transformer to cool.

Do not light the flame sensor or the burner will lock out; the burner should lock out anyway about 10 seconds after it starts.

4.12.5 Pressure variator

The pressure variator (Fig. 23), allows the pressure on the return line of the nozzle to be varied according to the required output.

The pressure on the return line is adjusted by varying a section by means of the rotation of the servomotor 10)(Fig. 4 on page 11), which also controls the gas butterfly valve at the same time.

- Regulator at 0° (maximum opening) = minimum pressure on the nozzle return line.
- Regulator at 90° (minimum opening) = maximum pressure on the nozzle return line.

The servomotor is controlled by the electronic cam 1)(Fig. 5 on page 12); thanks to this device, it is possible to set different curves for oil and gas on the same servomotor (also for the air damper servomotor 4)(Fig. 4 on page 11).

- In the **oil regulation** the regulation is carried out on the basis of the nozzle that has been mounted and the modulation required.

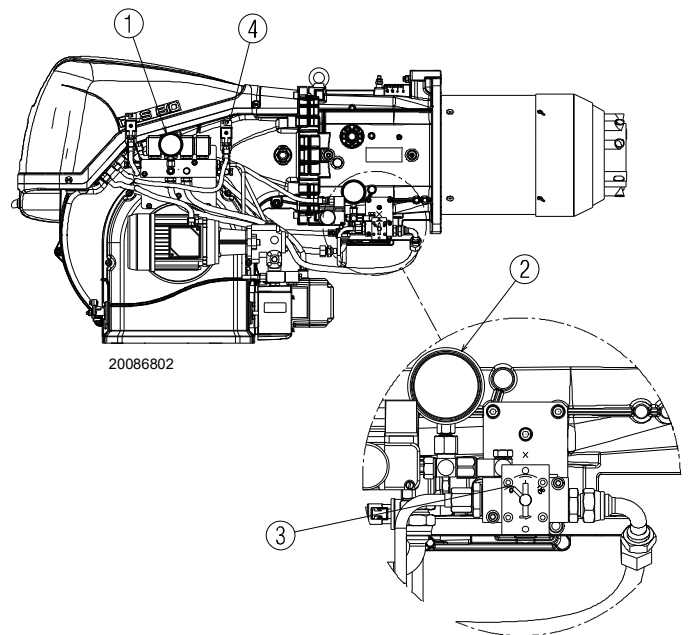

Fig. 23

Key (Fig. 23)

- 1 Nozzle delivery pressure gauge
- 2 Nozzle return pressure gauge
- 3 Position indicator (0 ÷ 90) of the pressure variator
- 4 Maximum oil pressure switch on return circuit

4.12.6 Hydraulic circuit diagram

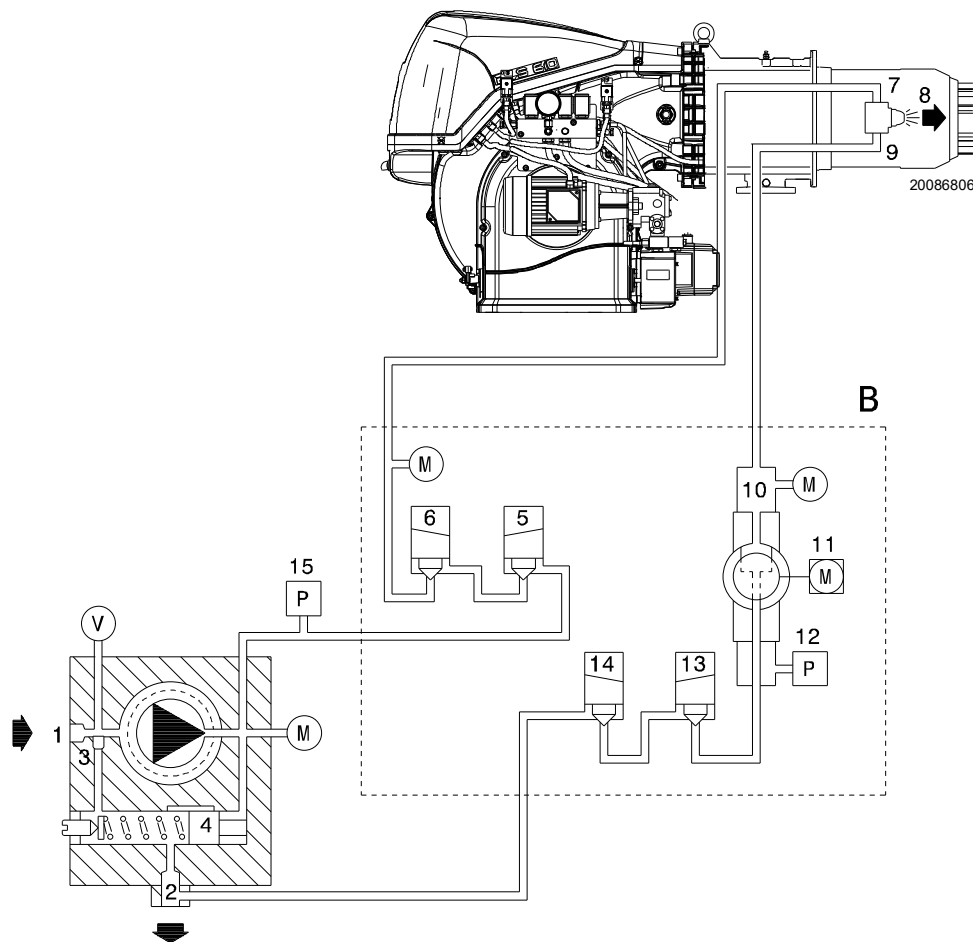

Fig. 24

Key (Fig. 24)

- 1 Pump suction
- 2 Pump return line and nozzle return line
- 3 Pump by-pass screw
- 4 Pump pressure regulator
- 5 Safety valve
- 6 Safety valve
- 7 Nozzle delivery line
- 8 Nozzle without interception rod
- 9 Nozzle return line
- 10 Pressure variator on nozzle return line
- 11 Pressure variator servomotor
- 12 Pressure switch on nozzle return line
- 13 Safety valve on nozzle return line
- 14 Safety valve on nozzle return line
- 15 Pressure switch on pump delivery line
- B Oil valve group and pressure variator
- M Pressure gauges
- V Vacuumeter connection



WARNING

The a.m. operation is possible because the pump is already full of fuel when it leaves the factory. If the pump has been drained, fill it with fuel through the opening on the vacuumeter 4)(Fig. 22 on page 26) prior to starting; otherwise, the pump will seize.

Whenever the length of the suction piping exceeds 20-30 meters, the supply line must be filled using a separate pump.

OPERATION

Pre-purging phase:

valves 5), 6), 13) and 14) closed.

Ignition and operation phase:

valves 5), 6), 13) and 14) open.

Stop: All valves closed.

4.13 Gas pressures



Explosion danger due to fuel leaks in the presence of a flammable source.

Precautions: avoid knocking, attrition, sparks and heat.

Make sure the fuel interception tap is closed before performing any operation on the burner.



WARNING

The fuel supply line must be installed by qualified personnel, in compliance with current standards and laws.

4.13.1 Gas feeding line (Example) - Please refer to the gas train documentation for more information

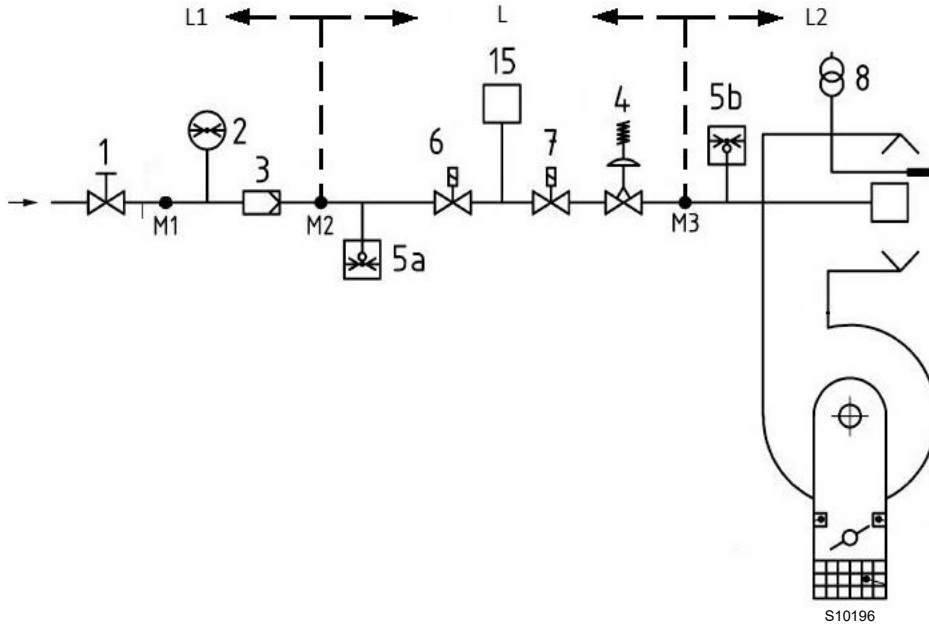

Fig. 25

Key (Fig. 25)

- 1 Manually operated shut-off valve
- 2 Pressure gauge
- 3 Filter
- 4 Governor
- 5a Low pressure protection device
- 5b Maximum gas pressure switch
- 6 1st safety shut-off device
- 7 2nd safety shut-off device
- 8 Ignition device
- 15 Valve leak detection control system
- L Gas train (supplied separately)
- L1 Responsibility of the installer
- L2 Burner
- M1 Pressure test point
- M2 Pressure test point
- M3 Pressure test point

4.13.2 Gas train

Approved according to standard EN 676 and provided separately from the burner.



Pay attention when handling the train: danger of crushing of limbs.

4.13.3 Gas train installation



DANGER

Disconnect the electrical power using the main switch.



Make sure that the gas train is properly installed by checking for any fuel leaks.



Check that there are no gas leaks.



The operator must use the required equipment during installation.

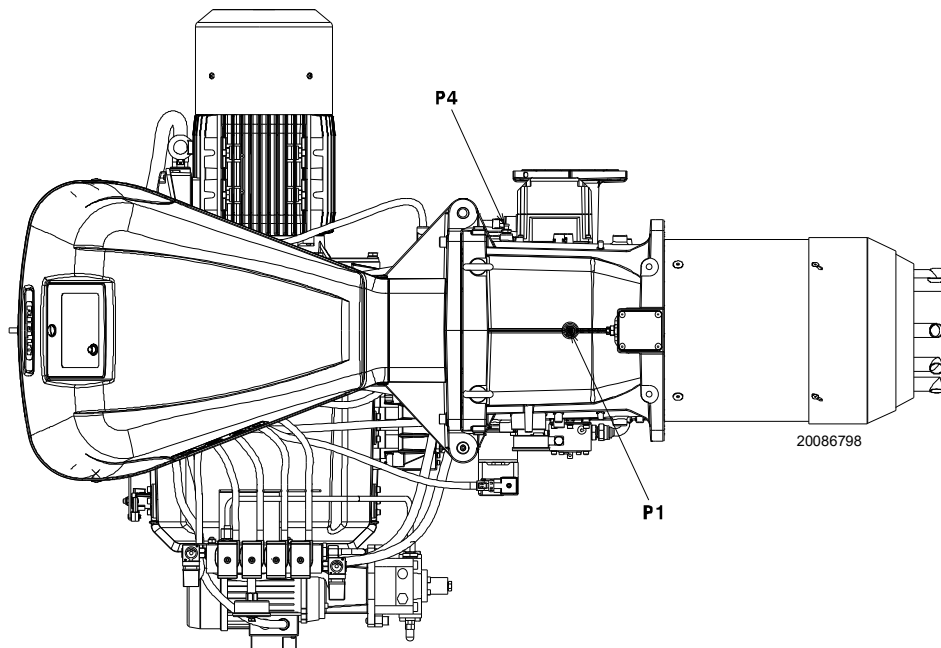

Fig. 26

4.13.4 Gas pressure

Tab. N indicates the minimum pressure drops along the gas supply line, depending on the maximum burner output.

The values shown in Tab. N refer to:

- Natural gas G 20 NCV 9.45 kWh/Sm³ (8.2 Mcal/Sm³)
- Natural gas G 25 NCV 8.13 kWh/Sm³ (7.0 Mcal/Sm³)

Column 1

Combustion head pressure drop.

Gas pressure measured at the test point P1)(Fig. 26), with:

- Combustion chamber at 0 mbar;
- Burner working at maximum output;
- Combustion head adjusted as in page 23.

Column 2

Pressure loss at gas butterfly valve 14)(Fig. 4 on page 11) with maximum opening: 90°.

Calculate the approximate maximum output of the burner in this way:

- subtract the combustion chamber pressure from the gas pressure measured at test point P1) (Fig. 26 on page 29).
- Find, in the table Tab. N related to the burner concerned, the pressure value closest to the result of the subtraction.
- Read the corresponding output on the left.

Example (RLS 310/EV O2 MX) with natural gas G20:

Maximum output operation

Gas pressure at test point P1) (Fig. 26 on page 29) = 24.3 mbar

Pressure in combustion chamber = 5 mbar
 24.3 - 5 = 19.3 mbar

A pressure of 19.3 mbar, column 1, corresponds in the table Tab. N to an output of 2800 kW.

This value serves as a rough guide; the effective output must be measured at the gas meter.

To calculate the required gas pressure at test point P1) (Fig. 26 on page 29), set the MAX output required from the burner operation:

- find the nearest output value in the table Tab. N for the burner in question.
- Read, on the right (column 1), the pressure at the test point P1) (Fig. 26 on page 29).
- Add this value to the estimated pressure in the combustion chamber.

Example (RLS 310/EV O2 MX) with natural gas G20:

Required burner maximum output operation: 3000 kW

Gas pressure at an output of 2800 kW = 19.3 mbar

Pressure in combustion chamber = 5 mbar
 19.3 + 5 = 24.3 mbar

Pressure required at test point P1)(Fig. 26).



The data of thermal output and combustion head gas pressure are related to full open (90°) gas butterfly valve.

	kW	1 Δp (mbar)		2 Δp (mbar)	
		G 20	G 25	G 20	G 25
RLS 310	1200	3.6	5.4	0.1	0.1
	1467	5.4	8.1	0.2	0.3
	1733	7.5	11.2	0.4	0.6
	2000	9.9	14.8	0.7	1.0
	2267	12.7	18.9	1.0	1.5
	2533	15.8	23.6	1.3	1.9
	2800	19.3	28.8	1.7	2.5
	3067	23.1	34.5	2.1	3.1
	3333	27.3	40.7	2.6	3.9
	3600	31.8	47.4	3.1	4.6
RLS 410	1500	6.4	9.5	0	0
	1800	9.0	13.4	0.2	0.3
	2100	12.2	18.2	0.5	0.7
	2400	15.8	23.6	0.8	1.2
	2700	19.9	29.7	1.2	1.8
	3000	24.4	36.4	1.7	2.5
	3300	29.4	43.9	2.3	3.4
	3600	34.9	52.1	2.9	4.3
	3900	40.9	61.0	3.6	5.4
	4200	47.3	70.6	4.4	6.6
RLS 510	1800	7.0	10.4	1.5	2.2
	2174	9.8	14.6	2.0	3.0
	2549	13.0	19.4	2.6	3.9
	2923	16.6	24.8	3.3	4.9
	3298	20.7	30.9	4.1	6.1
	3672	25.2	37.6	4.9	7.3
	4047	30.2	45.1	5.8	8.7
	4421	35.6	53.1	6.8	10.1
	4796	41.5	61.9	7.8	11.6
	5170	47.8	71.3	9.0	13.4
RLS 610	2200	8.7	13.0	2.7	4.0
	2639	12.5	18.6	3.9	5.8
	3079	17.1	25.5	5.3	7.9
	3518	22.3	33.3	6.9	10.3
	3958	28.2	42.1	8.7	13.0
	4397	34.8	51.9	10.7	16.0
	4837	42.1	62.8	13.0	19.4
	5276	50.1	74.7	15.4	23.0
	5716	58.8	87.7	18.1	27.0
	6155	68.2	101.8	21.0	31.3

Tab. N

4.14 Electrical wiring

Notes on safety for the electrical wiring



DANGER

- The electrical wiring must be carried out with the electrical supply disconnected.
- Electrical wiring must be made in accordance with the regulations currently in force in the country of destination and by qualified personnel. Refer to the wiring diagrams.
- The manufacturer declines all responsibility for modifications or connections different from those shown in the wiring diagrams.
- Check that the electrical supply of the burner corresponds to that shown on the identification label and in this manual.
- The burners equipped with LMV5... can operate in FS1 or FS2 mode. See specific manual LMV5... for continuous/intermittent operation. Refer to the following notes for the type of operation that has been set.
- The FS1 burners have been set for intermittent operation. This means that the burner should compulsorily be stopped at least once every 24 hours to enable the electric flame control to check its own safety and efficiency at start-up. Normally the boiler's thermostat/pressure switch ensures that the burner stops. If this is not the case, a time switch should be fitted in series to TL to stop the FS1 burner at least once every 24 hours. Refer to the wiring diagrams.
- The FS2 burners have been set for continuous operation. This means that the burner should compulsorily be stopped at least once every 72 hours to enable the electric flame control to check its own safety and efficiency at start-up. Normally, burner stopping is guaranteed by the boiler's thermostat/pressure switch. If this is not the case, a time switch should be fitted in series to TL to stop the FS2 burner at least once every 72 hours. Refer to the wiring diagrams.
- The electrical safety of the device is obtained only when it is correctly connected to an efficient earthing system, made according to current standards. It is necessary to check this fundamental safety requirement. In the event of doubt, have the electrical system checked by qualified personnel. Do not use the gas tubes as an earthing system for electrical devices.
- The electrical system must be suitable for the maximum power absorption of the device, as indicated on the label and in the manual, checking in particular that the section of the cables is suitable for that level of power absorption.
- For the main power supply of the device from the electricity mains:
 - do not use adapters, multiple sockets or extensions;
 - use a multiple pole switch with at least a 3 mm gap between the contacts (overvoltage category III), as envisaged by the present safety standards.
- Do not touch the device with wet or damp body parts and/or in bare feet.
- Do not pull the electric cables.
- Check the electric wiring inside the boiler complies with the national and local safety regulations.
- Live and neutral should not be mixed up (this could cause dangerous malfunctions, a loss of protection against electric shocks, etc.).
- Make sure the cable grommets of the connected cables comply with the relevant standards (e.g. EN60730 and EN60 335).
- When wiring the unit, make sure that AC 230V mains voltage cables are run strictly separate from extra low-voltage cables to avoid risks of electrical shock hazard.

Before carrying out any maintenance, cleaning or checking operations:



DANGER

Turn off the burner's power supply using the main system switch.



DANGER

Turn off the fuel interception tap.
Avoid condensate, ice and water leaks from forming.

If the cover is still present, remove it and proceed with the electrical wiring according to the wiring diagrams. Use flexible cables in compliance with the EN 60 335-1 standard.

4.14.1 Supply cables and external connections passage

All the cables to be connected to the burner must be threaded through cable grommets. The use of the cable grommets can take various forms; by way of example see Fig. 27.

Key (Fig. 27)

1	Electrical supply	Bore for M32
2	Consents and safety devices	Bore for M20
3	Minimum gas pressure switch	Bore for M20
4	VPS gas valve leak detection control kit	Bore for M20
5	Gas train	Bore for M20
6	Available	Bore for M20
7	Available	Bore for M16
8	Available	Bore for M32

A	Motor revolution sensor
B	Maximum gas pressure switch
C	Power supply servomotor
D	Servomotors return
E	Flame sensor
F	Oil valves
G	Pump motor
H	Minimum oil pressure switch
I	Maximum oil pressure switch

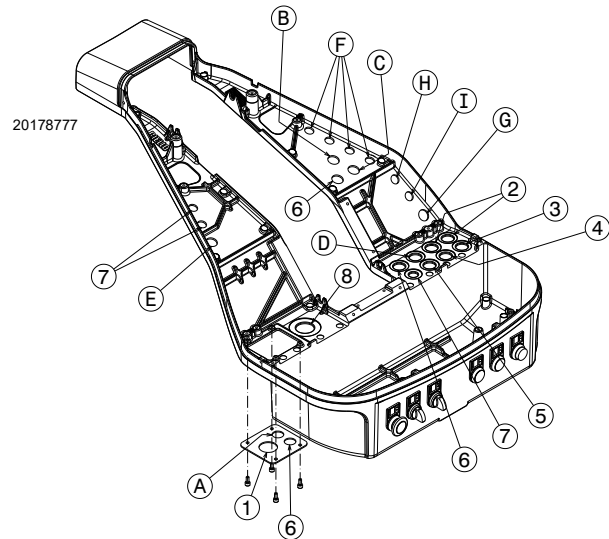

Fig. 27



After carrying out maintenance, cleaning or checking operations, reassemble the cover and all the safety and protection devices of the burner.

5 Start-up, calibration and operation of the burner

5.1 Notes on safety for the first start-up



WARNING

The first start-up of the burner must be carried out by qualified personnel, as indicated in this manual and in compliance with the standards and regulations of the laws in force.



WARNING

Check the correct working of the adjustment, command and safety devices.



WARNING

Refer to paragraph “Safety test - with gas ball valve closed” on page 41 before the first start-up.

5.2 Adjustments prior to ignition (light oil)



WARNING

It is recommended to adjust first the light oil burner and then the gas burner.
Carry out the fuel change with burner off.

The optimum calibration of the burner requires an analysis of the flue gases at the boiler outlet and interventions on the following points.

5.2.1 Nozzle

See information on “Nozzle installation” on page 24.

5.2.2 Combustion head

The adjustment of the combustion head already carried out on page 23 does not require any modifications if the burner output is not changed.

5.2.3 Pump pressure

In order to change pump pressure, act on screw 5)(Fig. 22 on page 26). See information on page 26.

5.3 Burner ignition (light oil)

Electrically power the burner using the disconnecting switch on the boiler panel.
Position the selector “OIL-EXT-GAS” (Fig. 28 on page 33) on “OIL” to select the light oil fuel.

Close the thermostats/pressure switches and set the switch of Fig. 28 on page 33 to “AUTO”.



DANGER

Make sure that the lights or testers connected to the solenoids, or the pilot lights on the solenoids themselves, indicate that no voltage is present. If voltage is present, stop the burner immediately and check the electrical connections.

As the burner is not fitted with a device to check the sequence of the phases, it may be that the rotation of the motor is incorrect.

As soon as the burner starts up, go in front of the fan motor cooling fan and make sure it is rotating anticlockwise or else in the direction of the arrow 26)(Fig. 4 on page 11).

If this is not the case:

- put the switch of Fig. 28 to “0” and wait until the flame control carries out the switching off phase;
- disconnect the burner from the electrical supply.



DANGER

Invert the phases on the motor power supply. This operation must be carried out with the electrical supply disconnected.

At the closing of the limit thermostat (TL), you must start the operating cycle of the flame control.

At first ignition, there is a momentary drop in fuel pressure due to the filling of the nozzle piping. This lowering of the fuel pressure can cause the burner to lockout and can sometimes give rise to pulsations.

Once the following adjustments have been made, the ignition of the burner must generate a noise similar to the noise generated during operation.

5.3.1 Burner adjustment (light oil)

The optimum adjustment of the burner requires an analysis of flue gases at the boiler outlet.

Adjust in sequence:

- 1 - Output upon ignition
- 2 - MAX output
- 3 - MIN output
- 4 - Intermediate outputs between Min. and Max.
- 5 - Air pressure switch
- 6 - Maximum oil pressure switch
- 7 - Minimum oil pressure switch

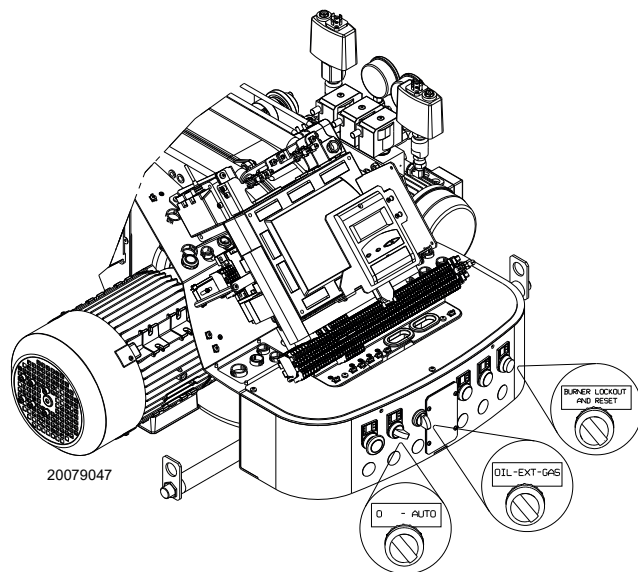

Fig. 28

5.4 Adjustments prior to ignition (gas)

Combustion head adjustment has already been already described in the section "Combustion head adjustment" on page 23.

In addition, the following adjustments must also be made:

- open manual valves upstream from the gas train.
- Adjust the minimum gas pressure switch to the start of the scale.
- Adjust the maximum gas pressure switch to the end of the scale.
- If necessary, adjust the air pressure switch (previously adjusted when operating with light oil).
- Adjust the pressure switch for the leak detection control (PVP kit) (Fig. 33 on page 37) according to the instructions supplied with the kit.
- Purge the air from the gas line.
We recommend using a plastic tube routed outside the building and to purge air until gas is smelt.
- Fit a U-type pressure gauge or a differential pressure gauge (Fig. 29), with socket (+) on the gas pressure of the pipe coupling and (-) in the combustion chamber.
The manometer readings are used to calculate MAX burner output using the Tab. N on page 30.
- Connect two lamps or testers to the two gas line solenoids to check the exact moment in which voltage is supplied. This operation is unnecessary if each of the two solenoids is equipped with a pilot light that signals voltage passing through.



Before starting up the burner, it is good practice to adjust the gas train so that ignition takes place in conditions of maximum safety, i.e. with gas delivery at the minimum.

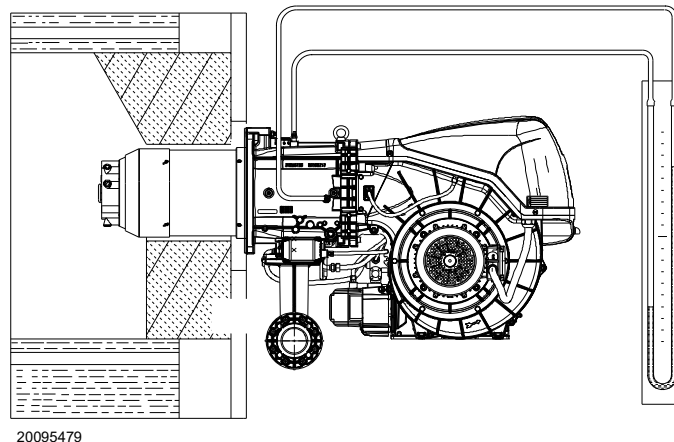

Fig. 29

5.5 Burner start-up (gas)

Close the remote controls and position the selector (Fig. 28 on page 33) on "ON".

Put the selector (Fig. 28 on page 33) on "GAS" to select gas as the fuel.

Make sure that the lights or testers connected to the solenoids, or the pilot lights on the solenoids themselves, indicate that no voltage is present. If voltage is present, stop the burner immediately and check the electrical connections.

When the limit thermostat (TL) closes, the burner begins the starting cycle.

5.6 Burner ignition

The burner should light after having performed the above steps. If the motor starts but the flame does not appear and the flame control goes into lockout, reset and wait for a new ignition attempt.

If ignition is still not achieved, it may be that gas is not reaching the combustion head within the safety time period of 3 seconds; In this case increase gas ignition delivery.

The arrival of gas at the sleeve is indicated by the U-type manometer (Fig. 29).

If the burner locks out again, see the chapter see "Faults - Possible causes - Solutions" on page 46.



In the event the burner stops, in order to prevent any damage to the installation, do not unblock the burner more than twice in a row. If the burner locks out for a third time, contact the customer service.



In the event there are further lockouts or faults with the burner, the maintenance interventions must only be carried out by qualified, authorised personnel, in accordance with the contents of this manual and in compliance with the standards and regulations of current laws.

5.7 Change of fuel

There are two change of fuel options:

- 1 with selector (Fig. 28 on page 33);
- 2 with a remote selector connected to the main terminal board.

Positioning the selector (Fig. 28 on page 33) to "EXT" activates the remote selection of the fuel. In this position, if there is no remote selector, the display shows the priority fuel.

5.8 Air / fuel adjustment

Air/fuel synchronisation is carried out with the relevant air, gas and light oil servomotors by logging a calibration curve using the electronic cam.

It is advisable, to reduce the loss and for a wide calibration field, to adjust the servomotors to the maximum of the output used, the nearest possible to the maximum opening (90°).

The choking of the air, taking into account the maximum combustion output, takes place by varying the adjustment of the combustion head (see "Combustion head adjustment" on page 23).

On the gas butterfly valve, the fuel step according to the burner output required, with servomotor completely open, is carried out by the pressure stabiliser on the gas train.

5.8.1 Air adjustment for maximum output

- Adjust the servomotor to maximum opening (nearly 90°) so that the air butterfly valves are entirely open.

5.8.2 Air/fuel adjustment and output modulation system

The air/gas regulator and output modulation system equipping the **RLS/EV MX** range of burners performs a number of integrated functions for the burner's total energy and operational optimisation, in both individual installations and in combination with other units (e.g. double furnace boiler or multiple heat generators in parallel).

The basic system functions control:

- 1 the dosage of the air and fuel through positioning using direct servo commands of the relevant valves eliminating the possible play in the calibration systems with mechanical cam lever mechanisms, used on traditional modulating burners;
- 2 the modulation of the burner output in accordance with the load required by the system, with maintenance of the pressure or temperature of the boiler at the operating values set;
- 3 the sequence (cascade adjustment) of more than one boiler through the suitable connection of the various units and the activation of the internal software of the individual systems (option).

Further interfaces and communication functions with computers, for remote control or integration in central supervision systems are available on the basis of the configuration of the system.



WARNING

The first start up and every further internal setting operation of the adjustment system or the expansion of the base functions require access by means of password and are to be carried out by service personnel who are especially trained for the internal programming of the instrument and the specific application created with this burner.

5.8.3 Burner adjustment (gas)

The optimum adjustment of the burner requires an analysis of flue gases at the boiler outlet.

Adjust in sequence:

- 1 - Output upon ignition
- 2 - MAX output
- 3 - MIN output
- 4 - Intermediate outputs between Min. and Max.
- 5 - Air pressure switch
- 6 - Maximum gas pressure switch
- 7 - Minimum gas pressure switch

5.8.4 Output upon ignition



WARNING

For safety purposes and correct product operation, the ignition output, if it is adjustable, must be carried out by authorized personnel and in compliance with the standards and regulations of the laws in force.

Air adjustment

The adjustment of the air is carried out by changing the angle of the air damper 17)(Fig. 4 on page 11) changing the degrees of the air servomotor inside the electronic cam programme.

5.8.5 Maximum output

The MAX output must be set within the firing rate (Fig. 2 on page 9).

Adjustment of gas delivery

Measure the gas delivery on the gas meter.

As an indicative guide it can be taken from Tab. N on page 30, just read the gas pressure on the pressure gauge (shown in Fig. 23 on page 26) and follow the instructions given on page 26.

- If it is necessary to reduce it, lower the output gas pressure via the pressure adjuster located beneath the gas valve.
- If delivery needs to be increased, increase the adjuster outlet gas pressure.

Air adjustment

If necessary vary the degrees of the air servomotor.

5.8.6 Minimum output

The MIN output must be set within the firing rate (Fig. 2 on page 9).

5.9 Final adjustment of the pressure switches

5.9.1 Air pressure switch

Adjust the air pressure switch (Fig. 30) after performing all other burner adjustments with the air pressure switch set to the start of the scale.

With the burner operating at minimum output, insert a combustion analyser in the stack, slowly close the suction inlet of the fan (for example, with a piece of cardboard) until the CO value does not exceed 100 ppm.

Slowly turn the appropriate knob clockwise until the burner goes into lockout.

Check the indication of the arrow pointing upwards on the graduated scale. Turn the knob clockwise again, until the value shown on the graduated scale corresponds with the arrow pointing downwards, and so recovering the hysteresis of the pressure

switch (shown by the white mark on a blue background, between the two arrows).

Now check the correct start-up of the burner. If the burner locks out again, turn the knob anti-clockwise a little bit more. During these operations it may be useful to measure the air pressure with a pressure gauge.

The connection of the pressure gauge is shown in Fig. 30. The standard configuration is that with the air pressure switch connected in absolute mode. Note the presence of a "T" connection, not supplied.



Connecting the air pressure switch in differential mode, the burner will no longer be certified according to the EN 676 standard.

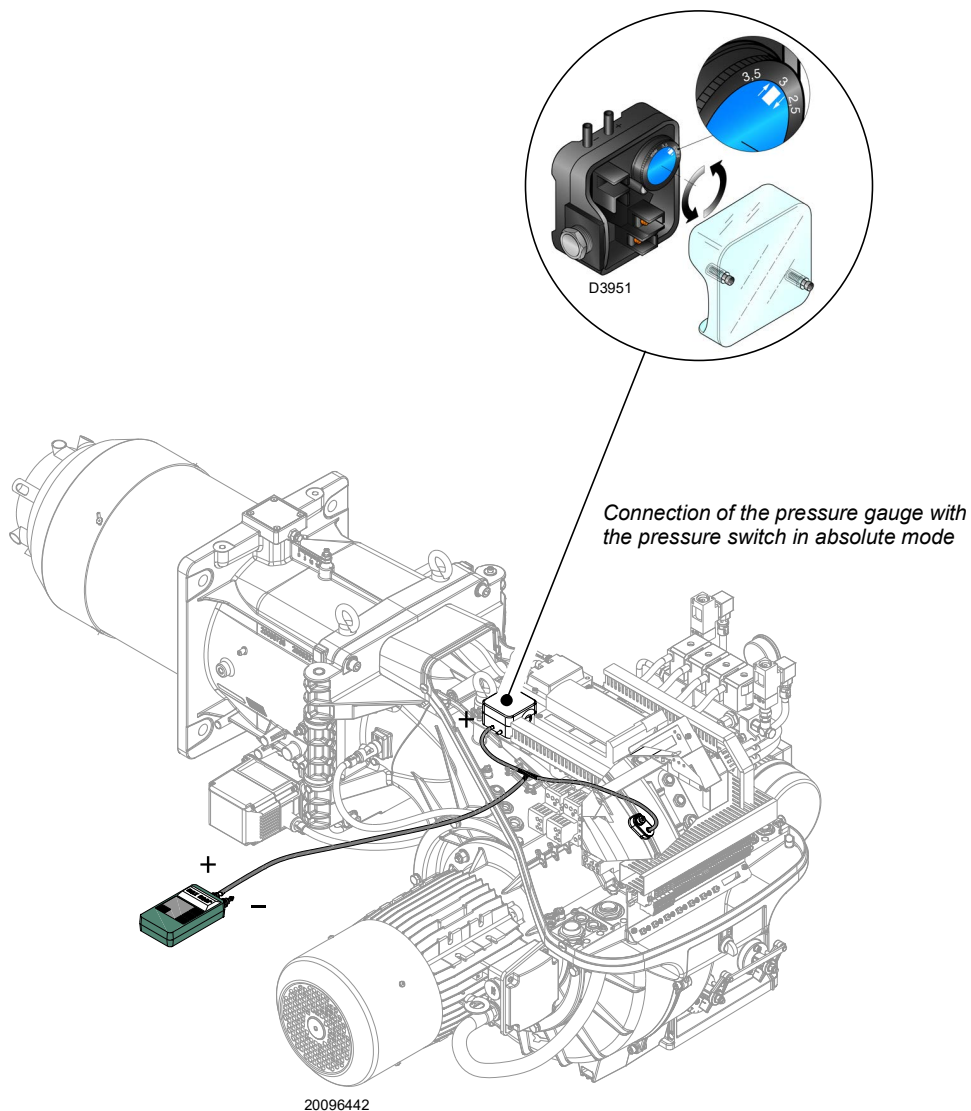

Fig. 30

5.10 Pressure switch adjustment

5.10.1 Maximum gas pressure switch

Adjust the maximum gas pressure switch (Fig. 31) after making all other burner adjustments with the maximum gas pressure switch set to the end of the scale.

To calibrate the maximum gas pressure switch, open the tap and then connect a pressure gauge to its pressure test point.

The maximum gas pressure switch must be regulated to a value no higher than 30% of the measurement read on the gauge when the burner is working at maximum output.

After making the adjustment, remove the pressure gauge and close the tap.

5.10.2 Minimum gas pressure switch

The purpose of the minimum gas pressure switch is to prevent the burner from operating in an unsuitable way due to too low gas pressure.

Adjust the minimum gas pressure switch (Fig. 32) after having adjusted the burner, the gas valves and the gas train stabiliser. With the burner operating at maximum output:

- install a pressure gauge downstream of the gas train stabiliser (for example at the gas pressure test point on the burner combustion head);
- choke slowly the manual gas cock until the pressure gauge detects a decrease in the pressure read of about 0.1 kPa (1 mbar). In this phase, verify the CO value which must always be less than 100 mg/kWh (93 ppm).
- Increase the adjustment of the gas pressure switch until it intervenes, causing the burner shutdown;
- remove the pressure gauge and close the cock of the gas pressure test point used for the measurement;
- open completely the manual gas cock.



1 kPa = 10 mbar

5.10.3 PVP pressure switch kit

Adjust the pressure switch for the leak detection control (PVP kit) (Fig. 33) according to the instructions supplied with the kit.

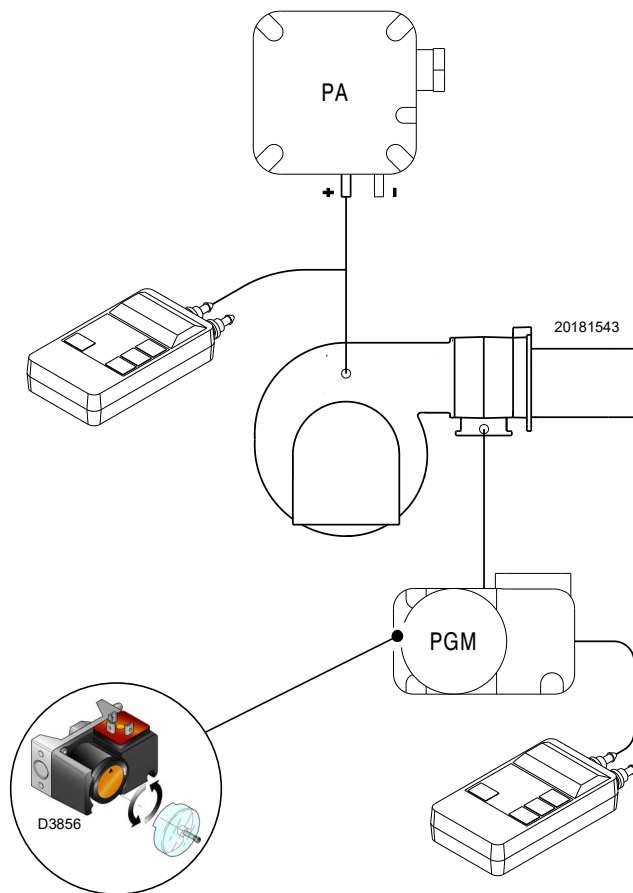

Fig. 31

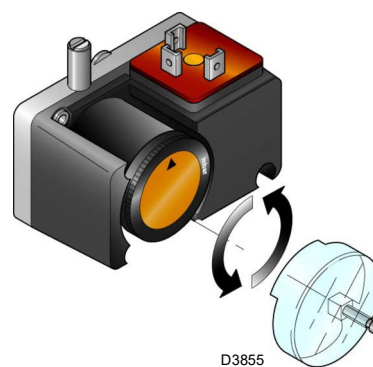

Fig. 32

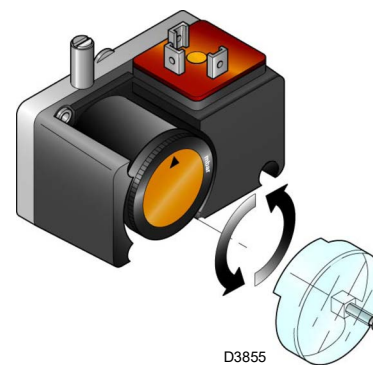

Fig. 33

5.10.4 Minimum oil pressure switch

The minimum oil pressure switch (Fig. 34) is calibrated in the factory at 18 bar.

If during the start-up phase the oil pressure drop or does not reach 18 bar, the burner goes to the ignition phase and the discharge of the transformer remains for 30s without opening the oil valve, after which there is a lockout and the display shows “Loc c 20 d0”.

If during the flame the oil pressure drops below 18 bar, the burner goes into lockout.

5.10.5 Maximum oil pressure switch

The maximum oil pressure switch (Fig. 35) is calibrated in the factory at 3 bar.

If during the ignition phase the oil pressure in the return line goes over 3 bar, the burner locks out.

if during the flame the oil pressure in the return line goes over 3 bar, the burner goes into lockout.

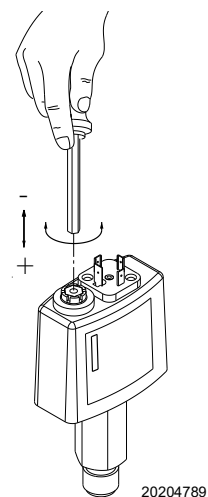

Fig. 34

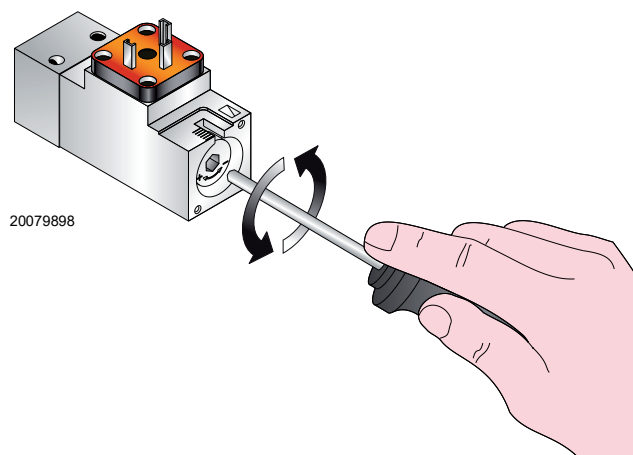

Fig. 35

5.11 Operation

Once the start-up cycle is completed, the servomotor command moves on to the thermostat/pressure switch that controls the pressure or the temperature in the boiler.

- If the temperature or the pressure is low, the burner progressively increases the output as far as the MAX value.
- If the temperature or the pressure increases, the burner progressively reduces the output as far as the MIN value. The sequence repeats endlessly.
- The burner stops when the heat request is less than the heat supplied by the burner at MIN output.
- The thermostat/pressure switch TL opens, the flame control carries out the switching off phase.
- The air damper closes completely to reduce heat losses to a minimum.

5.12 Ignition failure

If the burner does not switch on, there is a lockout within 3s of the electrical supply reaching the fuel valve.

It may be that the fuel does not arrive at the combustion head within the safety time of 3s.

In this case increase fuel ignition flow rate.



In the event the burner stops, in order to prevent any damage to the installation, do not unblock the burner more than twice in a row.

If the burner locks out for a third time, contact the customer service.



In the event there are further lockouts or faults with the burner, the maintenance interventions must only be carried out by qualified, authorised personnel, in accordance with the contents of this manual and in compliance with the standards and regulations of current laws.

5.13 Burner flame goes out during operation

If the flame accidentally goes out while running, the burner goes into lockout within 1 second.

5.14 Stopping of the burner

The burner can be stopped by:

- intervening on the disconnecting switch of the electrical supply line, located on the boiler panel;
- using the "0-AUTO" switch of Fig. 28 on page 33.



Make sure that the mechanical locking systems on the various adjustment devices are fully tightened.

5.15 Final checks

With the burner running

<ul style="list-style-type: none"> ➤ Open the thermostat/pressure switch TL ➤ Open the thermostat/pressure switch TS 	➡	the burner must stop
<ul style="list-style-type: none"> ➤ Turn the gas maximum pressure switch knob to the minimum end of scale position ➤ Turn the air pressure switch knob to the maximum end of scale position 	➡	the burner must stop in lockout
<ul style="list-style-type: none"> ➤ Disconnect the minimum gas pressure switch connector 	➡	the burner must stop in lockout
<ul style="list-style-type: none"> ➤ Disconnect the maximum oil pressure switch connector 	➡	the burner must stop in lockout
<ul style="list-style-type: none"> ➤ Disconnect the minimum oil pressure switch connector 	➡	the burner must stop in lockout
<ul style="list-style-type: none"> ➤ Obscure the flame sensor 	➡	the burner must stop in lockout due to flame loss

Tab. O

5.16 Pump motor lock-out

If the motor does not start, it could be because of a thermal relay intervention due to its incorrect calibration or problems with the motor or the main power supply, to release press the button of the thermal relay, see "Calibration of the thermal relay" on page 19.

5.17 Description of O₂ trim control (optional)

A special feature of the LMV52... is control of the residual O₂ content to increase the boiler's efficiency. The LMV52... uses a QGO20..., an external PLL52..., and the standard components of the LMV51... The PLL52... is a detached measuring module for the O₂ sensor and for 2 temperature sensors (Pt1000 / LG-Ni1000). The module communicates with the LMV52... via CAN bus.

The following generic diagram shows the system (Fig. 36).

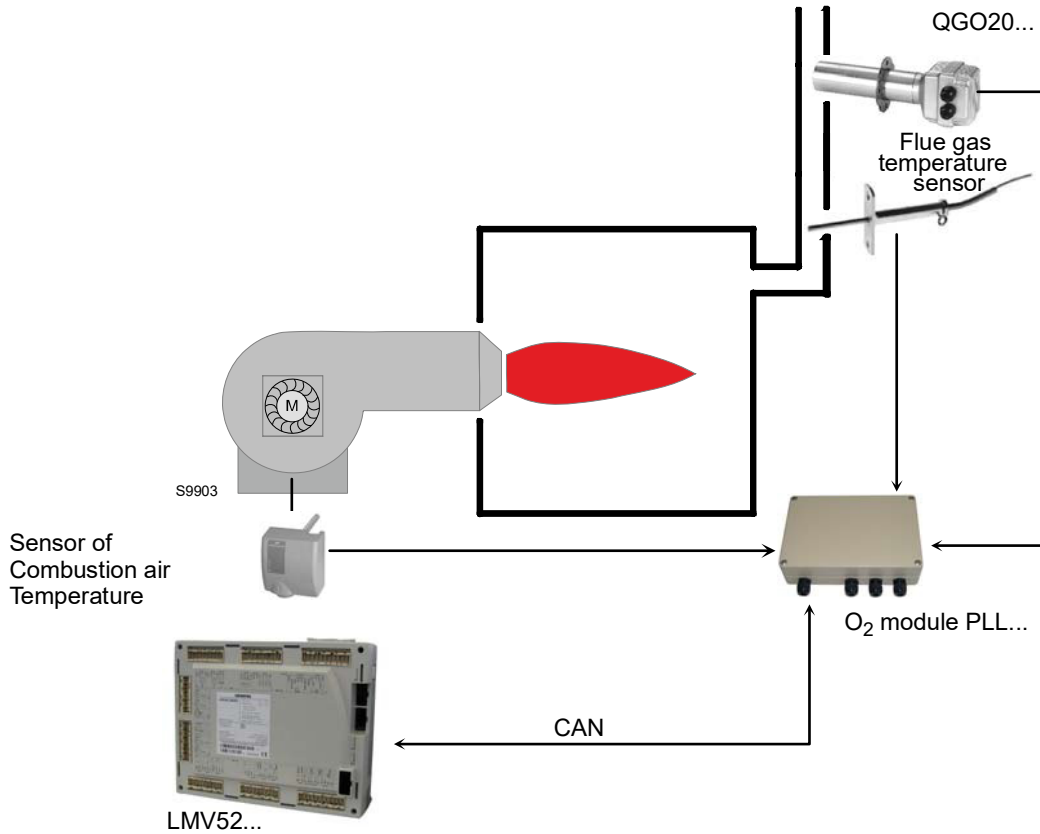

Fig. 36

5.17.1 Operating principle of O₂ trim control

The residual O₂ control system reduces the amount of combustion air depending on the control deviation (O₂ setpoint minus actual of O₂). The amount of combustion air is normally influenced by several actuators and, if used, by a VSD. **Reduction of the amount of air is reached by reducing the «air rate» of the air-regulating actuators.**

For that purpose, the damper positions of these actuators are calculated from some other load point on the ratio control curves. Hence, due to the parameterized ratio control curves, the air-regulating actuators are in a fixed relation to one another.

O₂ trim control is supported by **precontrol. It calculates the air rate reduction such that changes in burner load do not require the O₂ trim controller to interfere.** Consideration is given to a number of measured values that are ascertained when the burner is set. This means that the controller only becomes active when environmental conditions (temperature, pressure) change, and not when the burner load changes.



The installation and setting of the system must be carried out by qualified personnel, as indicated in the specific documentation of the device.

6 Maintenance

6.1 Notes on safety for the maintenance

The periodic maintenance is essential for the good operation, safety, yield and duration of the burner.

It allows you to reduce consumption and polluting emissions and to keep the product in a reliable state over time.



The maintenance interventions and the calibration of the burner must only be carried out by qualified, authorised personnel, in accordance with the contents of this manual and in compliance with the standards and regulations of current laws.

Before carrying out any maintenance, cleaning or checking operations:



Turn off the burner's power supply using the main system switch.



Turn off the fuel interception tap.

6.2 Maintenance programme

6.2.1 Maintenance frequency



The gas combustion system should be checked at least once a year by a representative of the manufacturer or another specialised technician.

6.2.2 Safety test - with gas ball valve closed

It is fundamental to ensure the correct execution of the electrical connections between the gas solenoid valves and the burner to perform safely the commissioning.

For this purpose, after checking that the connections have been carried out in accordance with the burner's electrical diagrams, an ignition cycle with closed gas ball valve -dry test- must be performed.

- 1 The manual ball gas valve must be closed
- 2 The electrical contacts of the burner limit switch need to be closed
- 3 Ensures closed the contact of the low gas pressure switch
- 4 Make a trial for burner ignition

The start-up cycle must be as follows:

- starting the fan for pre-ventilation
- Performing the gas valve seal control, if provided
- Completion of pre-ventilation
- Arrival of the ignition point
- Power supply of the ignition transformer
- Electrical Supply of solenoid gas valves

Since the manual gas ball valve is closed, the burner will not light up and its flame control will go to a safety lockout condition.

The actual electrical supply of the solenoid gas valves can be verified by inserting a tester. Some valves are equipped with light signals (or close/open position indicator) that turn on at the same time as their power supply.



IF THE ELECTRICAL SUPPLY OF THE GAS VALVES OCCURS AT UNEXPECTED TIMES, DO NOT OPEN MANUAL GAS BALL VALVE, SWITCH OFF POWER LINE; CHECK THE WIRES; CORRECT THE ERRORS AND REPEAT THE COMPLETE TEST.

6.2.3 Checking and cleaning



The operator must use the required equipment during maintenance.

Combustion

The optimum calibration of the burner requires an analysis of the flue gases.

Significant differences with respect to the previous measurements indicate the points where most care should be exercised during maintenance.

Combustion head

Open the burner and make sure that all components of the combustion head are in good condition, not deformed by the high temperatures, free of impurities from the surroundings and correctly positioned.

Burner

Clean the outside of the burner.

Clean and grease the adjustable profile of the cams.

Fan

Check to make sure that no dust has accumulated inside the fan or on its blades, as this condition will cause a reduction in the air flow rate and provoke polluting combustion.

Boiler

Clean the boiler as indicated in its accompanying instructions in order to maintain all the original combustion characteristics intact, especially the flue gas temperature and combustion chamber pressure.

Voltage on the sensor flame

Minimum value for correct operation: 3.5V DC (value on AZL display at about 50%).

If the value is lower, it could be due to:

- sensor not positioned correctly
- low voltage (lower than 187V)
- bad regulation of the burner

In order to measure, use a voltmeter with a 10V DC scale connected as in the diagram (Fig. 37).

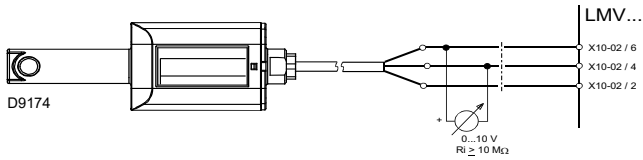

Fig. 37

6.2.4 Safety components

The safety components should be replaced at the end of their life cycle indicated in the Tab. P.

The specified life cycles do not refer to the warranty terms indicated in the delivery or payment conditions.

Safety component	Life cycle
Flame control	10 years or 250,000 operation cycles
Flame sensor	10 years or 250,000 operation cycles
Gas valves (solenoid)	10 years or 250,000 operation cycles
Pressure switches	10 years or 250,000 operation cycles
Pressure adjuster	15 years
Servomotor (electronic cam)	10 years or 250,000 operation cycles
Oil valve (solenoid)	10 years or 250,000 operation cycles
Oil regulator	10 years or 250,000 operation cycles
Pipes/ oil fittings (metallic)	10 years
Fan impeller	10 years or 500,000 start-ups

Tab. P

LIGHT OIL OPERATION

GAS OPERATION

Pump

The delivery pressure must comply with the table on page 30.
 The depression must be less than 0.45 bar.
Unusual noise must not be evident during pump operation.
 If the pressure is unstable, or the pump runs noisily, the flexible hose must be detached from the line filter and the fuel must be sucked from a tank located near the burner. This measure permits the cause of the anomaly to be traced to either the suction piping or the pump.
 If the problem lies in the suction line, check the filter is clean and that air is not entering the piping.

Nozzles

It is advisable to replace nozzles once a year during periodical maintenance.
 Do not clean the nozzle openings.

Hoses

Check that these are in good conditions.

Fuel tank

Approximately every 5 years, suck any water on the bottom of the tank using a separate pump.

Filters (Fig. 38)

Check the filtering baskets on line 1) and at nozzle 2) present in the system.
 Clean or replace if necessary.
 If rust or other impurities are observed inside the pump, use a separate pump to lift any water and other impurities that may have deposited on the bottom of the tank.

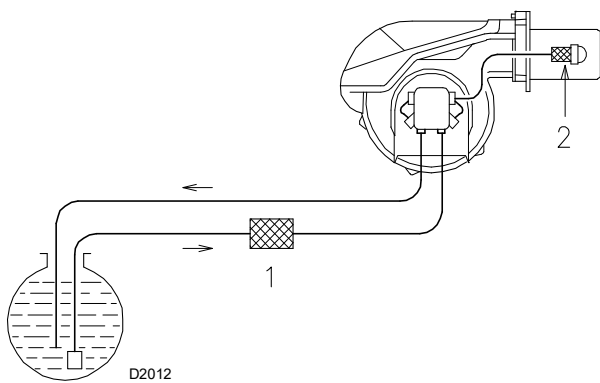

Fig. 38

Combustion

In case the combustion values found at the beginning of the intervention do not respect the standards in force or, in any case, do not correspond to a proper combustion, contact the Technical Assistance Service in order to carry out the necessary adjustments.

Gas leaks

Make sure that there are no gas leaks on the pipe between the gas meter and the burner.

Gas filter

Change the gas filter when it is dirty.

Combustion

In case the combustion values found at the beginning of the intervention do not respect the standards in force or, in any case, do not correspond to a proper combustion, contact the Technical Assistance Service in order to carry out the necessary adjustments.

EN 676		Air excess		
		Max. output. $\lambda \leq 1.2$		Min. output $\lambda \leq 1.3$
GAS	Theoretical max CO ₂ 0 % O ₂	Calibration CO ₂ %		CO mg/kWh
		$\lambda = 1.2$	$\lambda = 1.3$	
G 20	11.7	9.7	9.0	≤ 100
G 25	11.5	9.5	8.8	≤ 100
G 30	14.0	11.6	10.7	≤ 100
G 31	13.7	11.4	10.5	≤ 100

6.2.5 Checking the air and gas pressure on the combustion head

To carry out this operation it is necessary to use a pressure gauge to measure the air and gas pressure at the combustion head, as shown in Fig. 30 on page 36.

EN 267	Air excess		
	Max. output. $\lambda \leq 1.2$		Min. output $\lambda \leq 1.3$
Theoretical max CO ₂ 0 % O ₂	CO ₂ % Calibration		CO mg/kWh
	$\lambda = 1.2$	$\lambda = 1.3$	
15.2	12.6	11.5	≤ 100

6.3 Checking the position of the rpm sensor

To calibrate the rpm sensor 6)(Fig. 39), proceed as follows:

- remove the cover 1) unscrewing the screws 2);
- unscrew or screw the nuts 3) - 5) and the rpm detection disc 4) so that its distance from the sensor 6) is about 2 mm.;
- support the rpm detection disc 4) to the nut 5) and fix it by the lock nut 3);
- close the cover 1) screwing the screws 2).

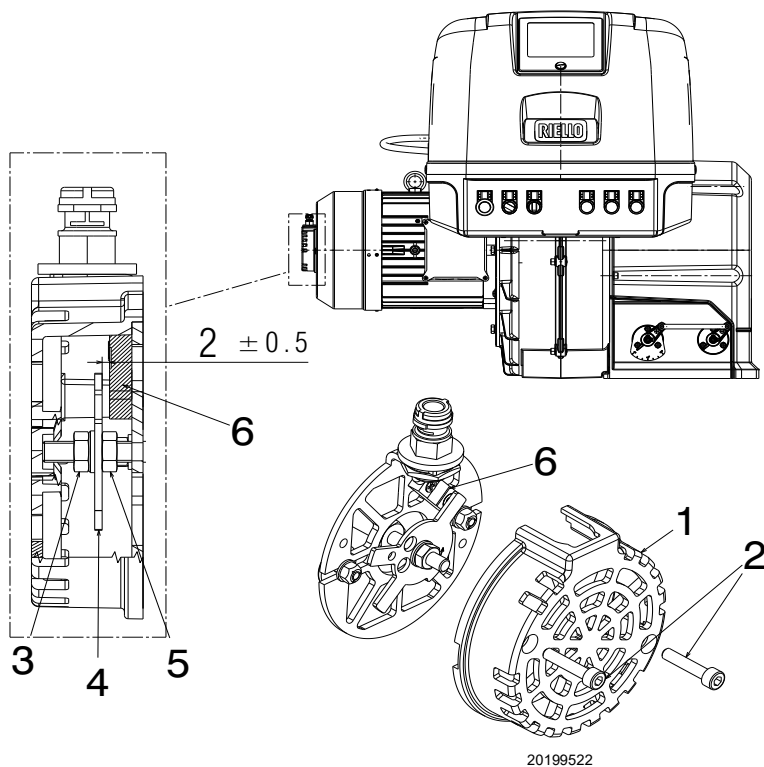

Fig. 39

Key (Fig. 39)

- 1 - Cover
- 2 - Screws for cover fixing
- 3 - Lock nut
- 4 - Rpm detection disc
- 5 - Lower nut
- 6 - Rpm sensor

6.4 Opening the burner



Disconnect the electrical supply from the burner by means of the main system switch.



Wait for the components in contact with heat sources to cool down completely.



Turn off the fuel interception tap.

See section “Access to head internal part” on page 22.

6.5 Closing the burner

Refit following the steps described but in reverse order; refit all burner components as they were originally assembled.



After carrying out maintenance, cleaning or checking operations, reassemble the cover and all the safety and protection devices of the burner.

7 **Faults - Possible causes - Solutions**

If faults arise in ignition or operations, the burner performs a "safety stop", which is signalled by the red burner lockout LED. The display of the operator panel visualises alternately the lock-out code and the relative diagnostic.
When the burner starts up again, the red LED goes out.

**WARNING**

In the event the burner stops, in order to prevent any damage to the installation, do not unblock the burner more than twice in a row.

If the burner locks out for a third time, contact the customer service.

**DANGER**

In the event there are further lockouts or faults with the burner, the maintenance interventions must only be carried out by qualified, authorised personnel, in accordance with the contents of this manual and in compliance with the standards and regulations of current laws.

A Appendix - Accessories**Soundproofing box kit**

Burner	Type	dB(A)	Code
All models	C7	10	3010376

Inverter kit (VSD)

Burner	Mains voltage	Motor output (kW)	Inverter output (kW)	Code
RLS 310/EV O2 MX	400V	7.5	7.5	20163074
RLS 410/EV O2 MX	400V	9.2	11	20163093
RLS 510/EV O2 MX	400V	12	15	20163096
RLS 610/EV O2 MX	400V	15	15	20163096

The use of inverters other than those indicated by the manufacturer may lead to burner failure and, in extreme cases, a potential risk of harm to people and damage to property.



WARNING

The manufacturing company shall not be liable for any such damage arising from non-observance of the requirements contained in this manual.

Continuous purging kit

Burner	Code
All models	20077810

Spacer kit

Burner	Code
All models	20008903

O₂ - CO control kit

Burner	Code
All models	20045187

HIGH-EFFICIENCY O₂ - CO control kit

Burner	Code
All models	3010377

Software interface kit (ACS450)

Burner	Code
All models	3010388

PVP kit (Seal control function - See gas train manual)

Burner	Gas Train type	Code
All models	MB - CB	3010344

Gas trains in compliance with EN 676

Please refer to manual.



WARNING

The installer is responsible for the addition of any safety device not foreseen in this manual.

B Appendix - Electrical panel layout

1	Index of layouts
2	Indication of references
3	Layout of unifilar output
4	Layout of unifilar output
5	LMV 52 ... functional layout
6	LMV 52 ... functional layout
7	LMV 52 ... functional layout
8	LMV 52 ... functional layout
9	LMV 52 ... functional layout
10	LMV 52 ... functional layout with kit
11	LMV 52 ... functional layout
12	PLL52/QGO20... operational layout with kit O2
12B	PLL52/QGO20... operational layout with kit O2
13	Electrical wiring that is the responsibility of the installer
14	Electrical wiring that is the responsibility of the installer
15	Electrical wiring that is the responsibility of the installer

2 Indication of references

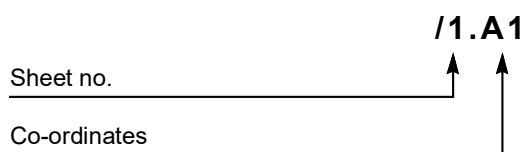

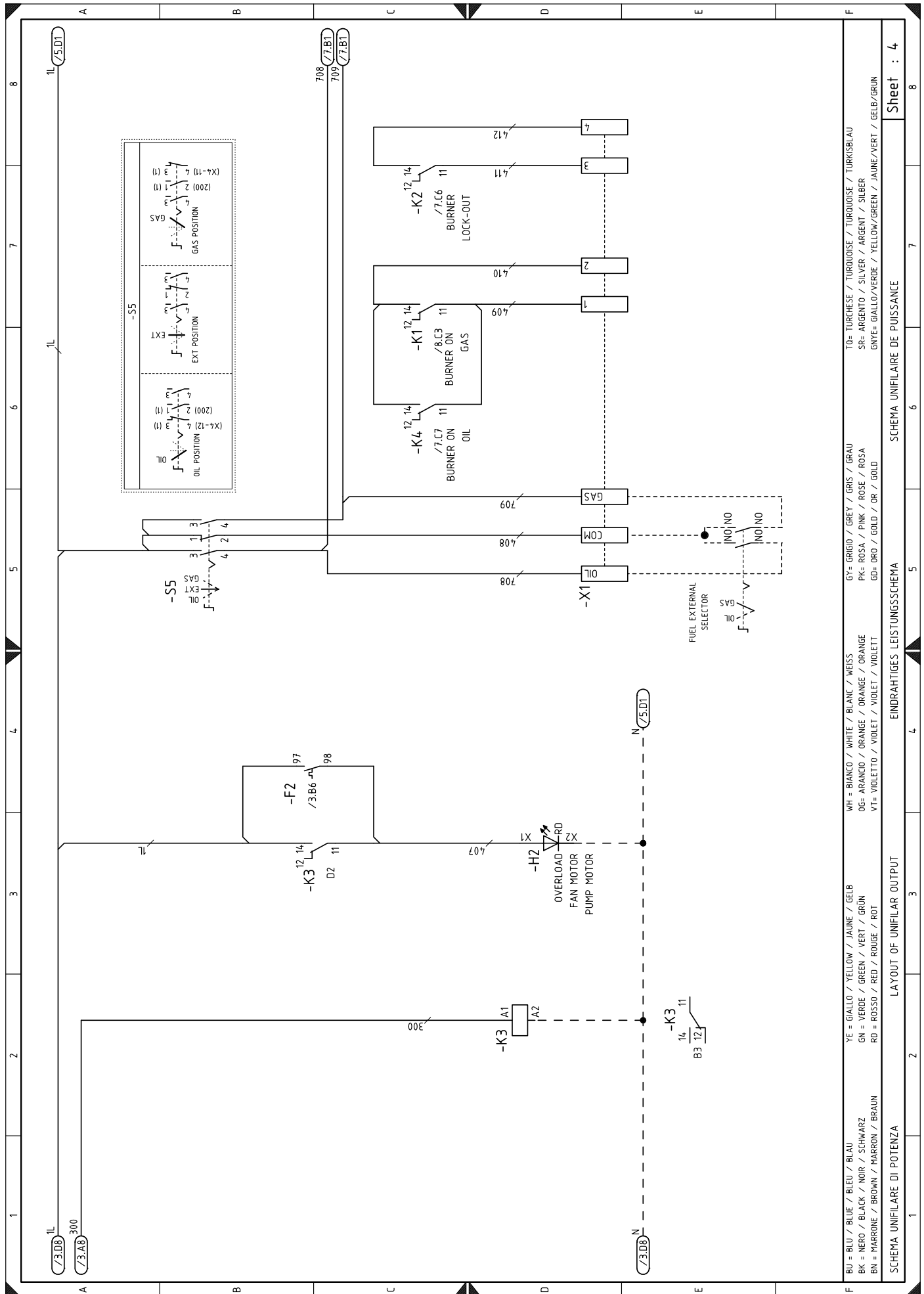

Sheet : 4

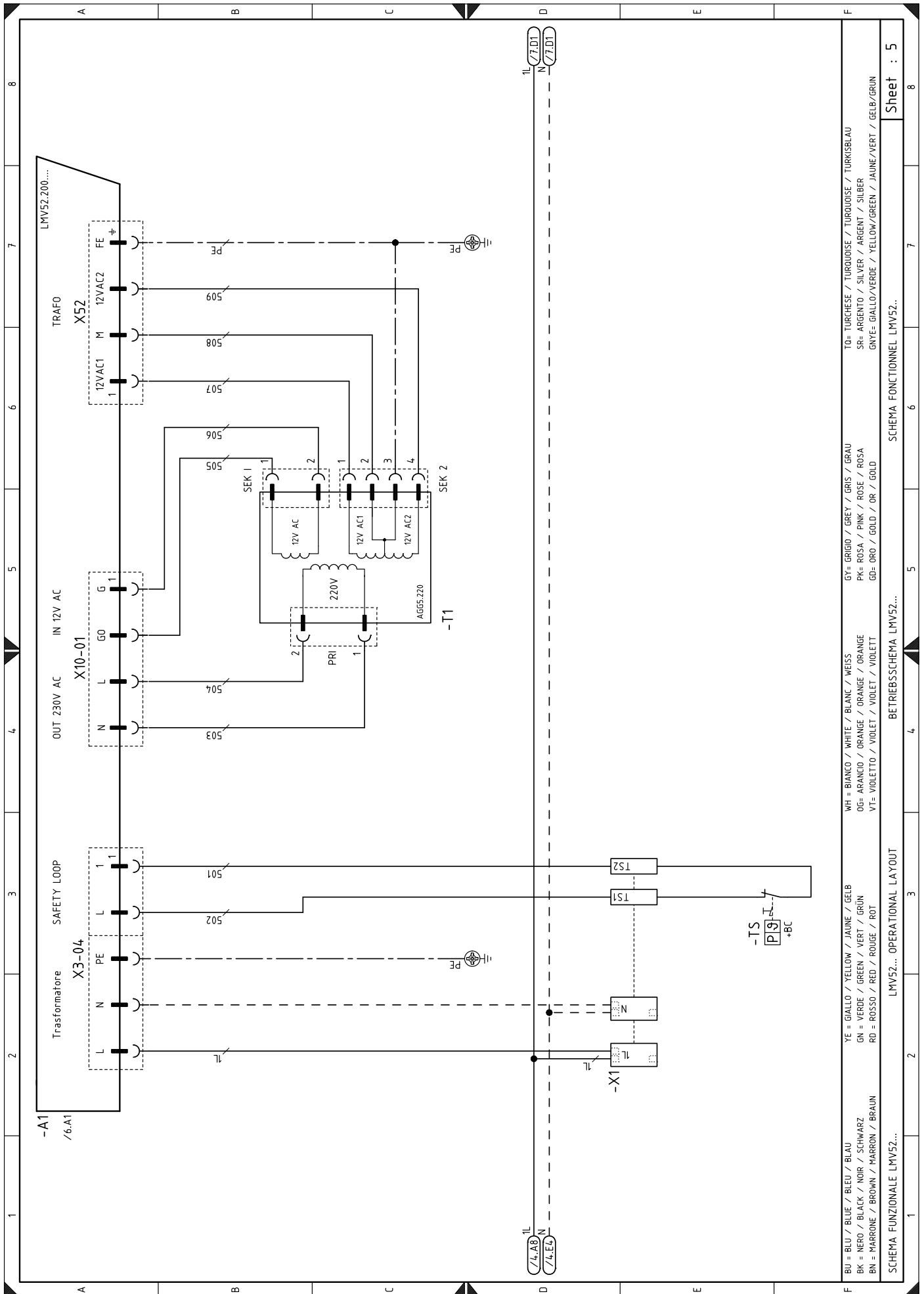

SCHEMA FUNZIONALE LMV52...
 SCHEMA FONCTIONNEL LMV52...
 OPERATIONAL LAYOUT
 BETRIEBSSCHEMA LMV52...
 LMV52... OPERATIONAL LAYOUT

BU = BLU / BLEU / BLAU
 BK = NERO / BLACK / SCHWARZ
 BN = MARRONE / BROWN / MARRON / BRAUN
 YE = GIALLO / YELLOW / JAUNE / GELB
 GN = VERDE / GREEN / VERT / GRÜN
 RD = ROSSO / RED / ROUGE / ROT
 WH = BIANCO / WHITE / BLANC / WEISS
 OG = ARANCIO / ORANGE / ORANGE / ORANGE
 VT = VIOLETTO / VIOLET / VIOLET / VIOLETT
 GY = GRIGIO / GREY / GRIS / GRAU
 PK = ROSA / PINK / ROSE / ROSA
 GD = ORO / GOLD / OR / GOLD
 TO = TURCHESE / TURQUOISE / TURQUOISE / TURKSBLAU
 SR = ARGENTO / SILVER / ARGENT / SILBER
 GNYE = GIALLO/VERDE / YELLOW/GREEN / JAUNE/VERT / GELB/GRÜN

Sheet : 5

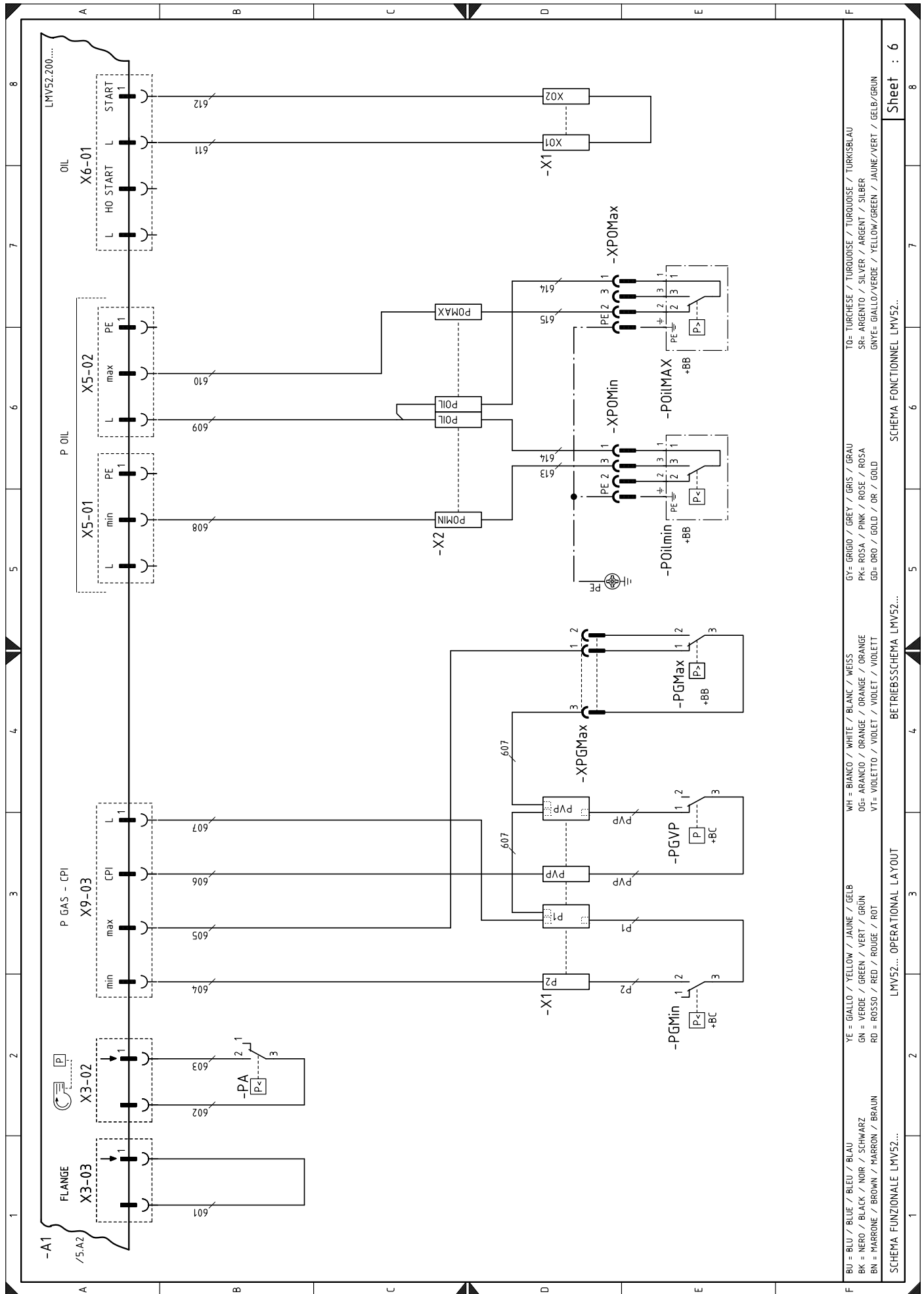

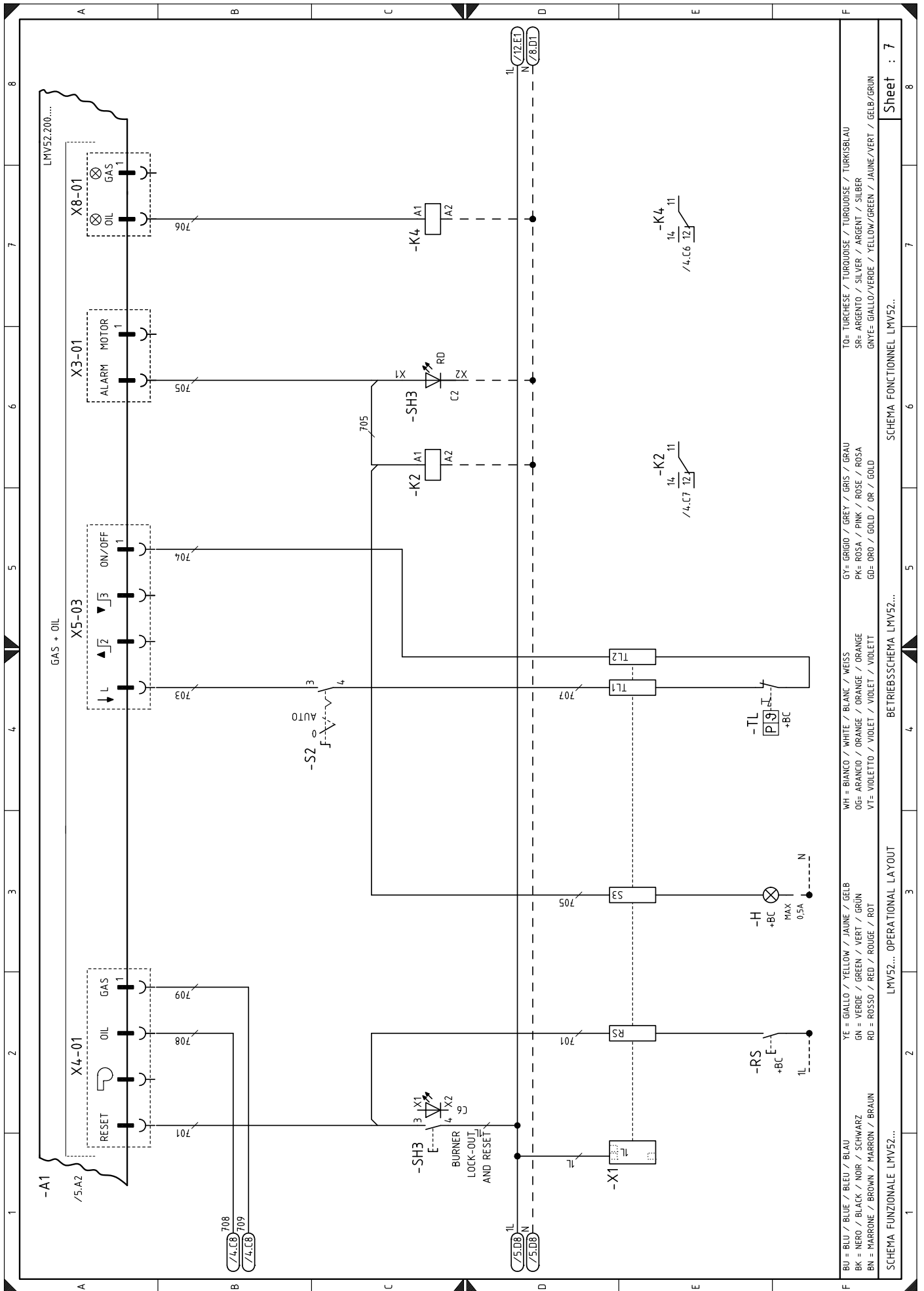

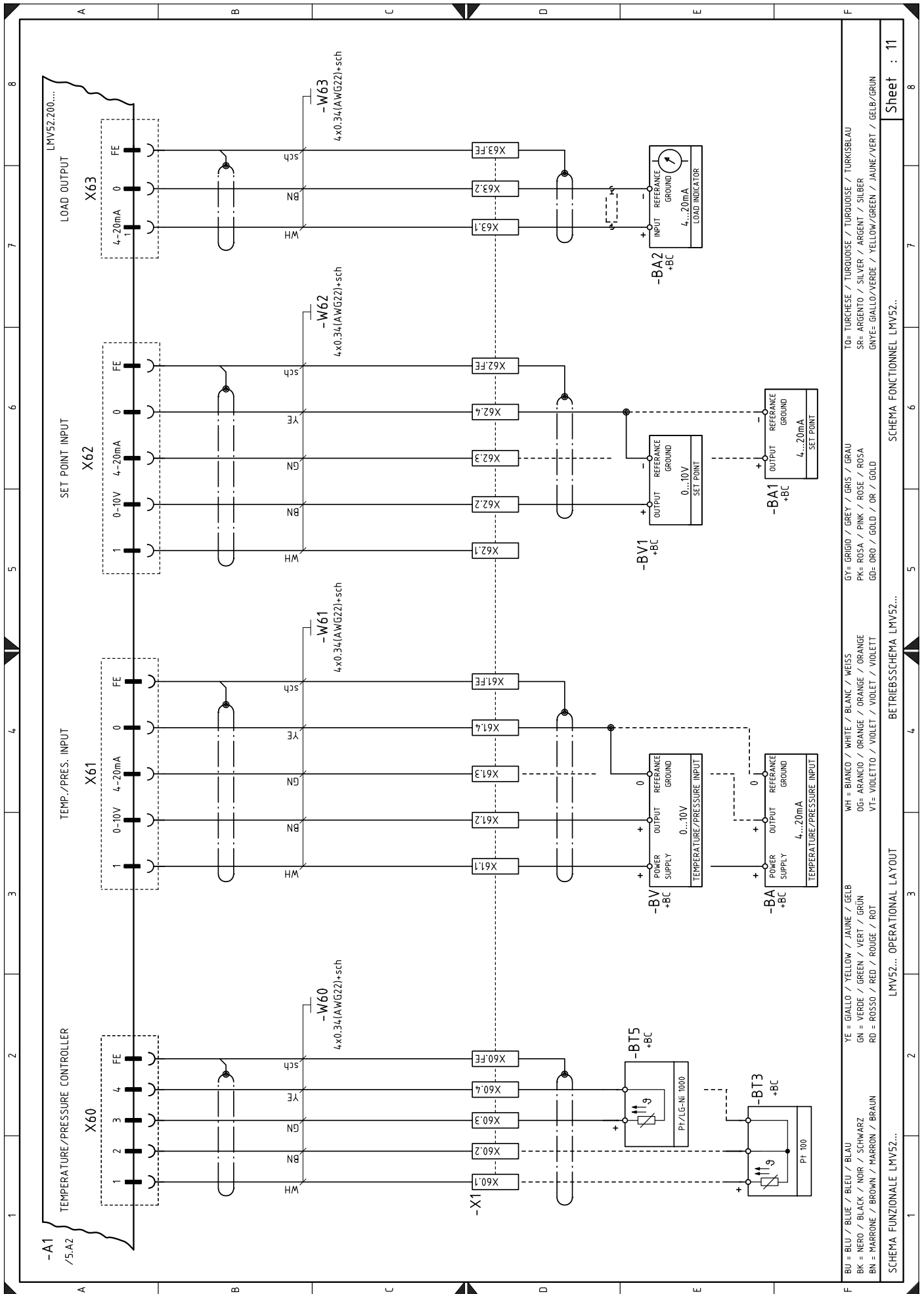

SCHEMA FUNZIONALE LMV52...
 OPERATIONAL LAYOUT
 BETRIEBSSCHEMA LMV52...
 SCHEMA FONCTIONNEL LMV52...
 Sheet : 11

YE = GIALLO / YELLOW / JAUNE / GELB
 GN = VERDE / GREEN / VERT / GRÜN
 RD = ROSSO / RED / ROUGE / ROT
 BK = NERO / BLACK / NOIR / SCHWARZ
 BN = MARRONE / BROWN / MARRON / BRAUN
 WH = BIANCO / WHITE / BLANC / WEISS
 OG = ARANCIO / ORANGE / ORANGE
 VT = VIOLETTO / VIOLET / VIOLETT
 GY = GRIGIO / GREY / GRIS / GRAU
 PK = ROSA / PINK / ROSE / ROSA
 GD = ORO / GOLD / OR / GOLD
 SR = ARGENTO / SILVER / ARGENT / SILBER
 GNYE = GIALLO/VERDE / YELLOW/GREEN / JAUNE/VERT / GELB/GRÜN
 TO = TURCHESE / TURKUISE / TURKUISBLAU
 LMV52... OPERATIONAL LAYOUT
 BETRIEBSSCHEMA LMV52...
 SCHEMA FONCTIONNEL LMV52...

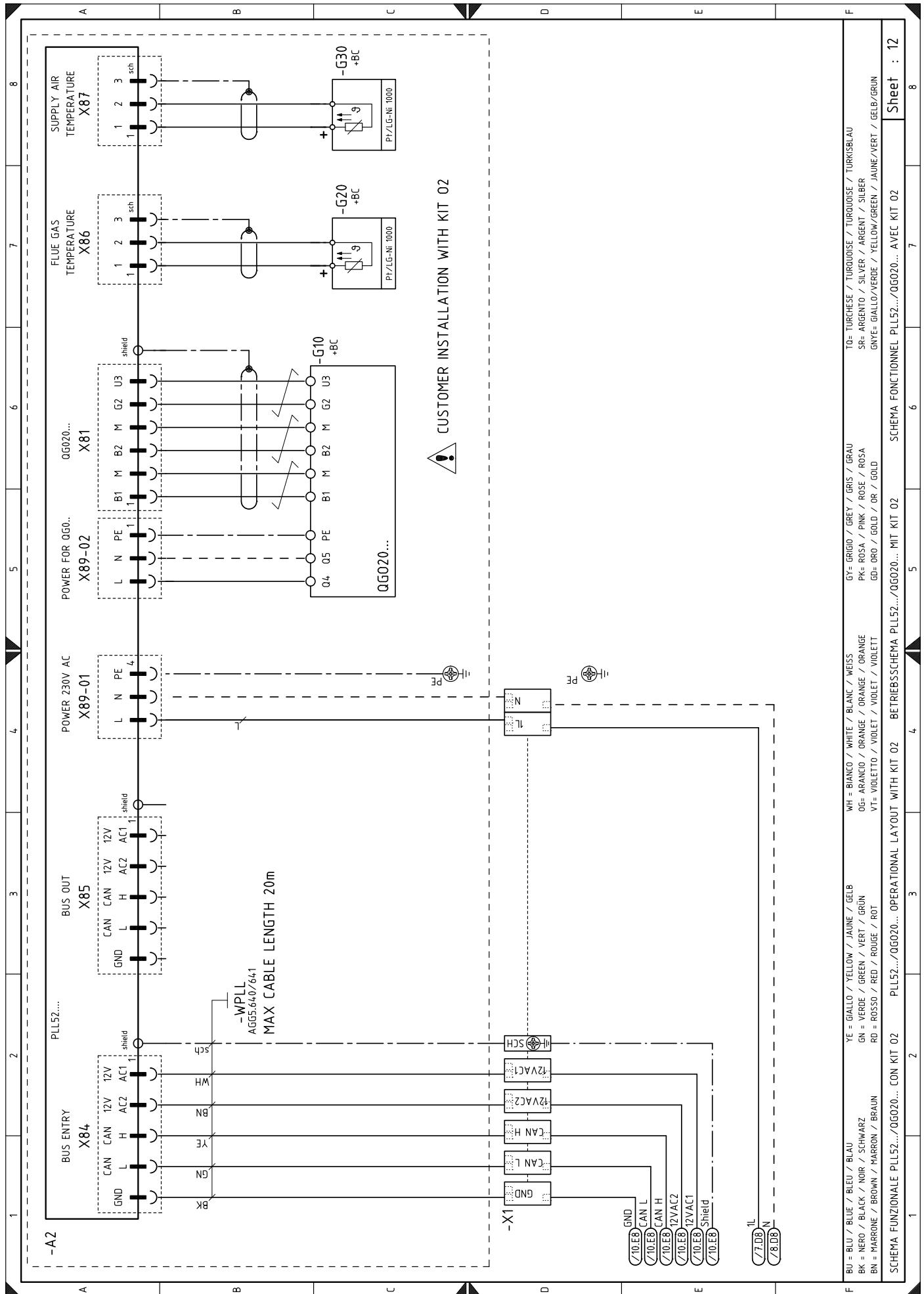

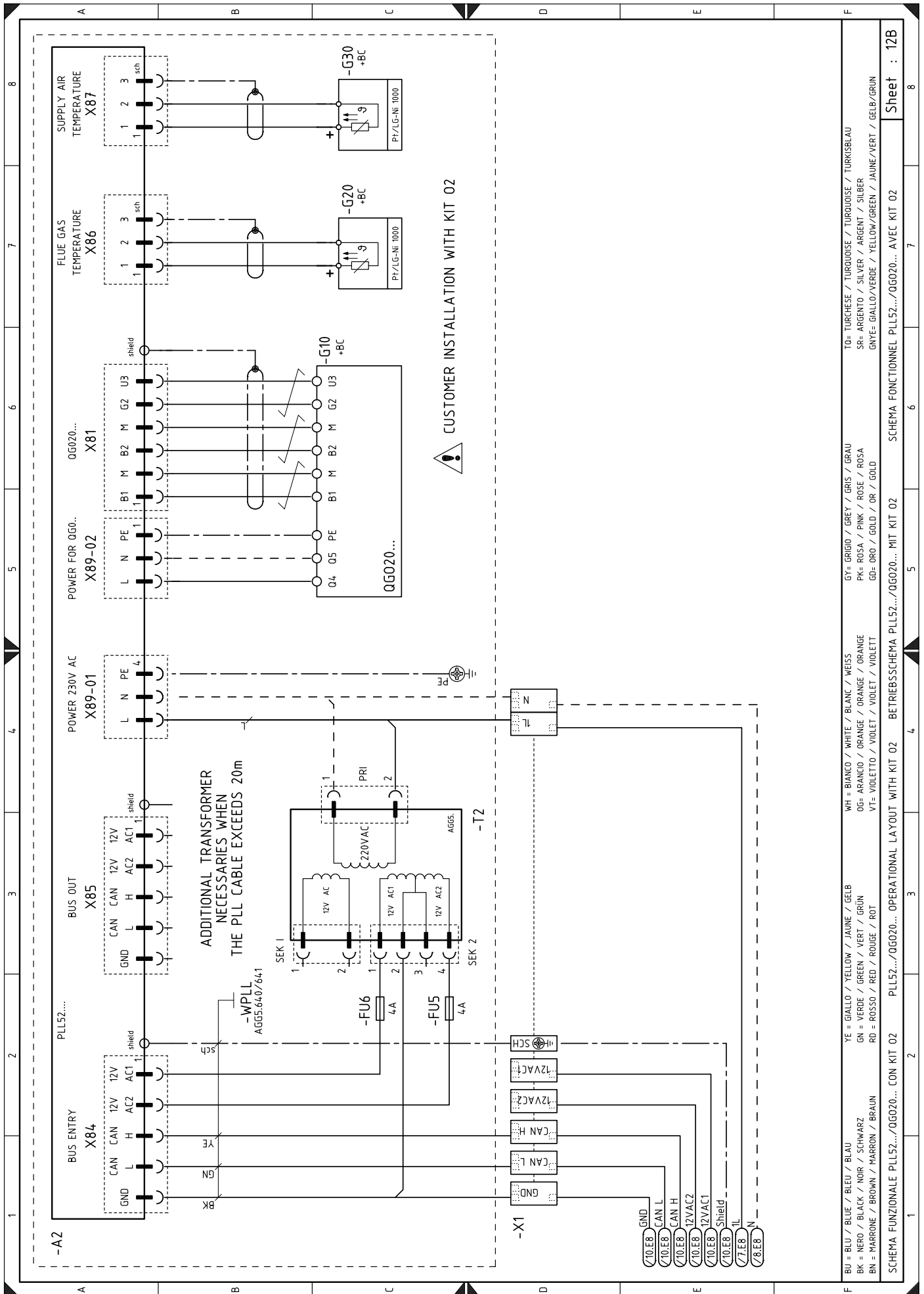

CUSTOMER INSTALLATION WITH KIT 02

BU = BLU / BLEU / BLEU / BLAU	YE = GIALLO / YELLOW / JAUNE / GELB	WH = BIANCO / WHITE / BLANC / WEISS	GY = GRIGIO / GREY / GRIS / GRAU	TO = TURCHESE / TURKUISE / TURKUISE / TURKSBLAU
BK = NERO / BLACK / NOIR / SCHWARZ	GN = VERDE / GREEN / VERT / GRUN	OG = ARANCIO / ORANGE / ORANGE / ORANGE	PK = ROSA / PINK / ROSE / ROSA	SR = ARGENTO / SILVER / ARGENT / SILBER
BN = MARRONE / BROWN / MARRON / BRAUN	RD = ROSSO / RED / ROUGE / ROT	VT = VIOLETTO / VIOLET / VIOLETT	GD = ORO / GOLD / OR / GOLD	GRYE = GIALLO/VERDE / YELLOW/GREEN / JAUNE/VERT / GELB/GRUN

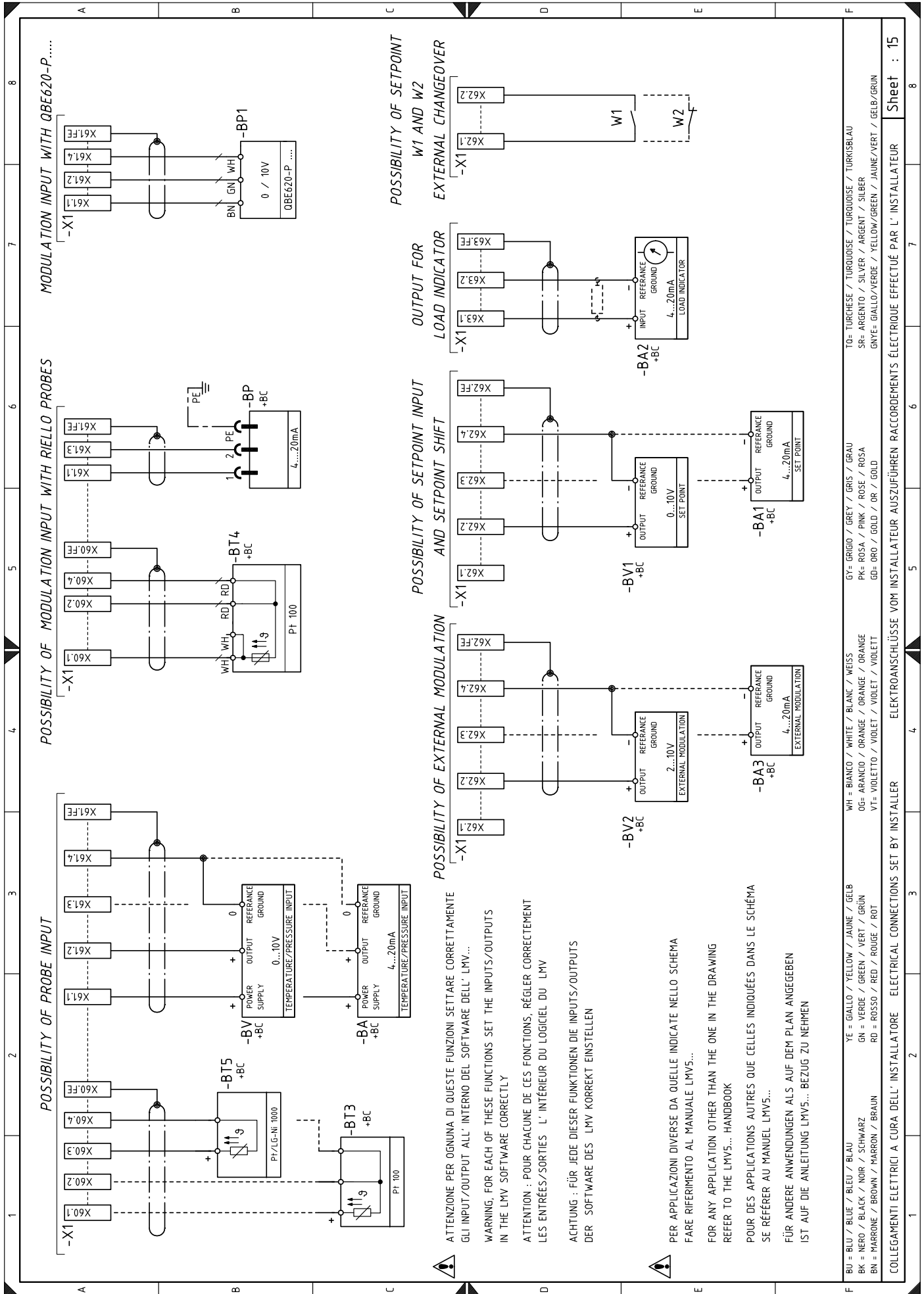

Wiring layout key

A1	Electronic cam
A2	Module O2 - type PLL
AZL	Display and operating unit
B1	Output power regulator RWF... internal
+BB	Burner components
+BC	Boiler components
BA	Output probe in current DC 4...20 mA
BA1	Output device in current DC 4...20 mA to modify remote setpoint
BA2	Load indicator
BA3	Probe for input in current DC 4...20 mA
BP	Pressure probe
BP1	Pressure probe
BT3	Probe Pt100, 3 wires
BT4	Probe Pt100, 3 wires
BT5	Probe PT/LG-Ni1000
BV	Output probe in voltage DC 0...10V
BV1	Output probe in voltage DC 0...10V to modify remote setpoint
BV2	Output probe in voltage 2...10V
F2	Pump motor thermal relay
FU	Auxiliary circuits safety fuse
G2	Motor revolution sensor
G10	Sensor O2 - type QGO20
G20	Flue gases air temperature control probe
G30	Air temperature control probe
GF	Inverter
H1	Green indicator "POWER-ON"
H2	Red indicator "OVERLOAD FAN MOTOR PUMP MOTOR"
K1	Clean contacts output relay burner switched on
K2	Clean contacts output relay burner lockout
K3	Clean contacts output relay inverter lockout
K4	Clean contacts output relay OIL operation
KMP	Pump motor contactor
MP	Pump motor
MV	Fan motor
PA	Air pressure switch
PE	Earth burner
PGMax	Max. gas pressure switch
PGMin	Min. gas pressure switch
PGVP	Gas pressure switch for leak detection control device
PoilMax	Max. oil pressure switch
PoilMin	Min. oil pressure switch
QRI	Flame sensor
RS	Remote reset button
S1	Emergency stop push-button
S2	"0/AUTO" selector
S5	Fuel selector
SH3	Burner reset button and lockout warning
SM1	Air servomotor
SM2	Gas servomotor
SVOIL	External valve oil safety
T1	Electronic cam ignition transformer
T2	Transformer (optional) for O2 module
TA	Ignition transformer
TL	Limit pressure switch/thermostat
TS	Safety pressure switch/thermostat
VF	Light oil operation valve
VR	Light oil return valve
VS	Light oil safety valve
VS1	Light oil safety valve on return
X1	Terminal board
X2	Valve group terminal board
Y	Gas adjustment valve + gas safety valve

RIELLO

RIELLO S.p.A.
I-37045 Legnago (VR)
Tel.: +39.0442.630111
[http:// www.riello.it](http://www.riello.it)
[http:// www.riello.com](http://www.riello.com)