

GB **Dual fuel light oil/gas burners**

Two-stage progressive or modulating operation gas side / two-stage light oil side

CE

**UK
CA**

EAC

CODE	MODEL	TYPE
20205746	RLS 250/M MZ	1302 T
20208628	RLS 250/M MZ	1302 T



Original instructions

1	Information and general warnings.....	3
1.1	Information about the instruction manual	3
1.1.1	Introduction.....	3
1.1.2	General dangers.....	3
1.1.3	Other symbols	3
1.1.4	Delivery of the system and the instruction manual	4
1.2	Guarantee and responsibility.....	4
2	Safety and prevention.....	5
2.1	Introduction.....	5
2.2	Personnel training	5
3	Technical description of the burner	6
3.1	Burner designation	6
3.2	Models available.....	6
3.3	Burner categories - Countries of destination	6
3.4	Technical data	7
3.5	Electrical data.....	7
3.6	Maximum dimensions.....	8
3.7	Firing rates	8
3.8	Test boiler.....	9
3.9	Commercial boiler	9
3.10	Burner equipment.....	9
3.11	Burner description	10
3.12	Electrical panel description.....	11
3.13	Flame control (LFL.....)	12
3.14	Servomotor (SQN31.....)	13
4	Installation	14
4.1	Notes on safety for the installation	14
4.2	Handling	14
4.3	Preliminary checks	14
4.4	Preparing the boiler.....	15
4.4.1	Boring the boiler plate	15
4.4.2	Blast tube length.....	15
4.5	Securing the burner to the boiler	15
4.5.1	Choice of nozzles for 1st and 2nd stage	15
4.6	Nozzle installation	16
4.7	Pump motor rotation.....	17
4.8	Light oil supply.....	18
4.8.1	Double-pipe circuit.....	18
4.8.2	Loop circuit.....	18
4.8.3	Hydraulic circuit diagram	19
4.8.4	Hydraulic connections (Fig. 20).....	19
4.8.5	Priming pump	19
4.8.6	Suntec J7 C pump.....	19
4.9	Gas supply	20
4.9.1	Gas feeding line (Example) - Please refer to the gas train documentation for more information.....	20
4.9.2	Gas train.....	21
4.9.3	Gas train installation.....	21
4.9.4	Gas pressure.....	21
4.10	Electrical wiring	22
4.10.1	Supply cables and external connections passage	22
4.11	Calibration of the thermal relay	23
4.12	Motor rotation	23
5	Start-up, calibration and operation of the burner	24
5.1	Notes on safety for the first start-up	24
5.2	Adjustments prior to ignition (light oil)	24
5.2.1	Combustion head adjustment.....	24
5.2.2	Pump adjustment	24
5.2.3	Fan damper adjustment	24
5.3	Burner ignition (light oil).....	24
5.4	Burner adjustment (light oil)	24

5.5	Adjustments prior to ignition (gas)	25
5.6	Burner start-up	25
5.7	Burner ignition	25
5.7.1	Burner adjustment	25
5.7.2	Ignition output	25
5.7.3	Maximum output	25
5.7.4	Minimum output	26
5.7.5	Intermediate outputs	27
5.8	Servomotor adjustment	27
5.9	Change of fuel	28
5.10	Pressure switch adjustment	28
5.10.1	Air pressure switch - check CO	28
5.10.2	Maximum gas pressure switch	28
5.10.3	Minimum gas pressure switch	29
5.11	Burner operation	30
5.11.1	Burner start-up	30
5.11.2	Steady state operation	30
5.11.3	Ignition failure	30
5.11.4	Final checks (with burner operating)	30
6	Maintenance	31
6.1	Notes on safety for the maintenance	31
6.2	Maintenance programme	31
6.2.1	Maintenance frequency	31
6.2.2	Safety test - with no gas supply	31
6.2.3	Checking and cleaning	31
6.2.4	Combustion control (gas)	33
6.2.5	Safety components	33
6.3	Opening the burner	34
6.4	Closing the burner	34
7	Faults - Possible causes - Solutions	35
7.1	Light oil operation	36
7.2	Gas operation	38
A	Appendix - Accessories	40
B	Appendix - Electrical panel layout	41

1 Information and general warnings

1.1 Information about the instruction manual

1.1.1 Introduction

The instruction manual supplied with the burner:

- is an integral and essential part of the product and must not be separated from it; it must therefore be kept carefully for any necessary consultation and must accompany the burner even if it is transferred to another owner or user, or to another system. If the manual is lost or damaged, another copy must be requested from the Technical Assistance Centre of the area;
- is designed for use by qualified personnel;
- offers important indications and instructions relating to the installation safety, start-up, use and maintenance of the burner.

Symbols used in the manual

In some parts of the manual you will see triangular DANGER signs. Pay great attention to these, as they indicate a situation of potential danger.

1.1.2 General dangers

The **dangers** can be of **3 levels**, as indicated below.



Maximum danger level!
This symbol indicates operations which, if not carried out correctly, cause serious injury, death or long-term health risks.



This symbol indicates operations which, if not carried out correctly, may cause serious injury, death or long-term health risks.



This symbol indicates operations which, if not carried out correctly, may cause damage to the machine and/or injury to people.

1.1.3 Other symbols



DANGER: LIVE COMPONENTS
This symbol indicates operations which, if not carried out correctly, lead to electric shocks with lethal consequences.



DANGER: FLAMMABLE MATERIAL
This symbol indicates the presence of flammable materials.



DANGER: BURNING
This symbol indicates the risks of burns due to high temperatures.



DANGER: CRUSHING OF LIMBS
This symbol indicates the presence of moving parts: danger of crushing of limbs.



WARNING: MOVING PARTS
This symbol indicates that you must keep limbs away from moving mechanical parts; danger of crushing.



DANGER: EXPLOSION

This symbol signals places where an explosive atmosphere may be present. An explosive atmosphere is defined as a mixture - under atmospheric conditions - of air and flammable substances in the form of gases, vapours, mist or dust in which, after ignition has occurred, combustion spreads to the entire unburned mixture.



PERSONAL PROTECTION EQUIPMENT

These symbols indicate the equipment that must be worn and kept by the operator for protection against threats against safety and/or health while at work.



OBLIGATION TO ASSEMBLE THE COVER AND ALL THE SAFETY AND PROTECTION DEVICES

This symbol signals the obligation to reassemble the cover and all the safety and protection devices of the burner after any maintenance, cleaning or checking operations.



ENVIRONMENTAL PROTECTION

This symbol gives indications for the use of the machine with respect for the environment.



IMPORTANT INFORMATION

This symbol indicates important information that you must bear in mind.

- This symbol indicates a list.

Abbreviations used

Ch.	Chapter
Fig.	Figure
Page	Page
Sec.	Section
Tab.	Table

1.1.4 Delivery of the system and the instruction manual

When the system is delivered, it is important that:

- the instruction manual is delivered to the user by the system manufacturer, with the recommendation to keep it in the room where the heat generator is to be installed.
- The instruction manual shows:
 - the serial number of the burner;

.....

- the address and telephone number of the nearest Assistance Centre

.....
.....
.....

- The system supplier must carefully inform the user about:
 - the use of the system;
 - any further tests that may be required before activating the system;
 - maintenance, and the need to have the system checked at least once a year by a representative of the manufacturer or another specialised technician. To ensure a periodic check, the manufacturer recommends the drawing up of a Maintenance Contract.

1.2 Guarantee and responsibility

The manufacturer guarantees its new products from the date of installation, in accordance with the regulations in force and/or the sale contract. At the moment of the first start-up, check that the burner is integral and complete.



ATTENTION

Failure to observe the information given in this manual, operating negligence, incorrect installation and carrying out of non authorised modifications will result in the annulment by the manufacturer of the guarantee that it supplies with the burner.

In particular, the rights to the guarantee and the responsibility will no longer be valid, in the event of damage to things or injury to people, if such damage/injury was due to any of the following causes:

- incorrect installation, start-up, use and maintenance of the burner;
- improper, incorrect or unreasonable use of the burner;
- intervention of unqualified personnel;
- carrying out of unauthorised modifications on the equipment;
- use of the burner with safety devices that are faulty, incorrectly applied and/or not working;
- installation of untested supplementary components on the burner;
- powering of the burner with unsuitable fuels;
- faults in the fuel supply system;
- continuation of use of the burner when a fault has occurred;
- repairs and/or overhauls incorrectly carried out;
- modification of the combustion chamber with inserts that prevent the regular development of the structurally established flame;
- insufficient and inappropriate surveillance and care of those burner components most likely to be subject to wear and tear;
- use of non-original components, including spare parts, kits, accessories and optional;
- force majeure.

The manufacturer furthermore declines any and every responsibility for the failure to observe the contents of this manual.

2 Safety and prevention

2.1 Introduction

The burners have been designed and built in compliance with current regulations and directives, applying the known safety technical rules and envisaging all the potential danger situations.

It is necessary, however, to bear in mind that the imprudent and clumsy use of the equipment may lead to situations of death risk for the user or third parties, as well as the damaging of the burner or other items. Inattention, thoughtlessness and excessive confidence often cause accidents; the same applies to tiredness and sleepiness.

It is a good idea to remember the following:

- The burner must only be used as expressly described. Any other use should be considered improper and therefore dangerous.

Specifically:

it can be applied to boilers operating with water, steam, diathermic oil, and to other uses expressly named by the manufacturer;

the type and pressure of the fuel, the voltage and frequency of the electrical power supply, the minimum and maximum deliveries for which the burner has been regulated, the pressurisation of the combustion chamber, the dimensions of the combustion chamber and the ambient temperature must all be within the values indicated in the instruction manual.

- Modification of the burner to alter its performance and destinations is not allowed.
- The burner must be used in exemplary technical safety conditions. Any disturbances that could compromise safety must be quickly eliminated.
- Opening or tampering with the burner components is not allowed, apart from the parts requiring maintenance.
- Only those parts envisaged by the manufacturer can be replaced.



The manufacturer guarantees safety and proper functioning only if all burner components are intact and positioned correctly.

2.2 Personnel training

The user is the person, body or company that has acquired the machine and intends to use it for the specific purpose. He is responsible for the machine and for the training of the people working around it.

The user:

- undertakes to entrust the machine exclusively to suitably trained and qualified personnel;
- undertakes to inform his personnel in a suitable way about the application and observance of the safety instructions. With that aim, the user undertakes to ensure that everyone knows the use and safety instructions for his own duties;
- Personnel must observe all the danger and caution indications shown on the machine.
- Personnel must not carry out, on their own initiative, operations or interventions that are not within their province.
- Personnel must inform their superiors of every problem or dangerous situation that may arise.
- The assembly of parts of other makes, or any modifications, can alter the characteristics of the machine and hence compromise operating safety. The manufacturer therefore declines any and every responsibility for any damage that may be caused by the use of non-original parts.

In addition:



- must take all the measures necessary to prevent unauthorised people gaining access to the machine;
- the user must inform the manufacturer if faults or malfunctioning of the accident prevention systems are noticed, along with any presumed danger situation;
- personnel must always use the personal protective equipment envisaged by legislation and follow the indications given in this manual.

3 Technical description of the burner

3.1 Burner designation

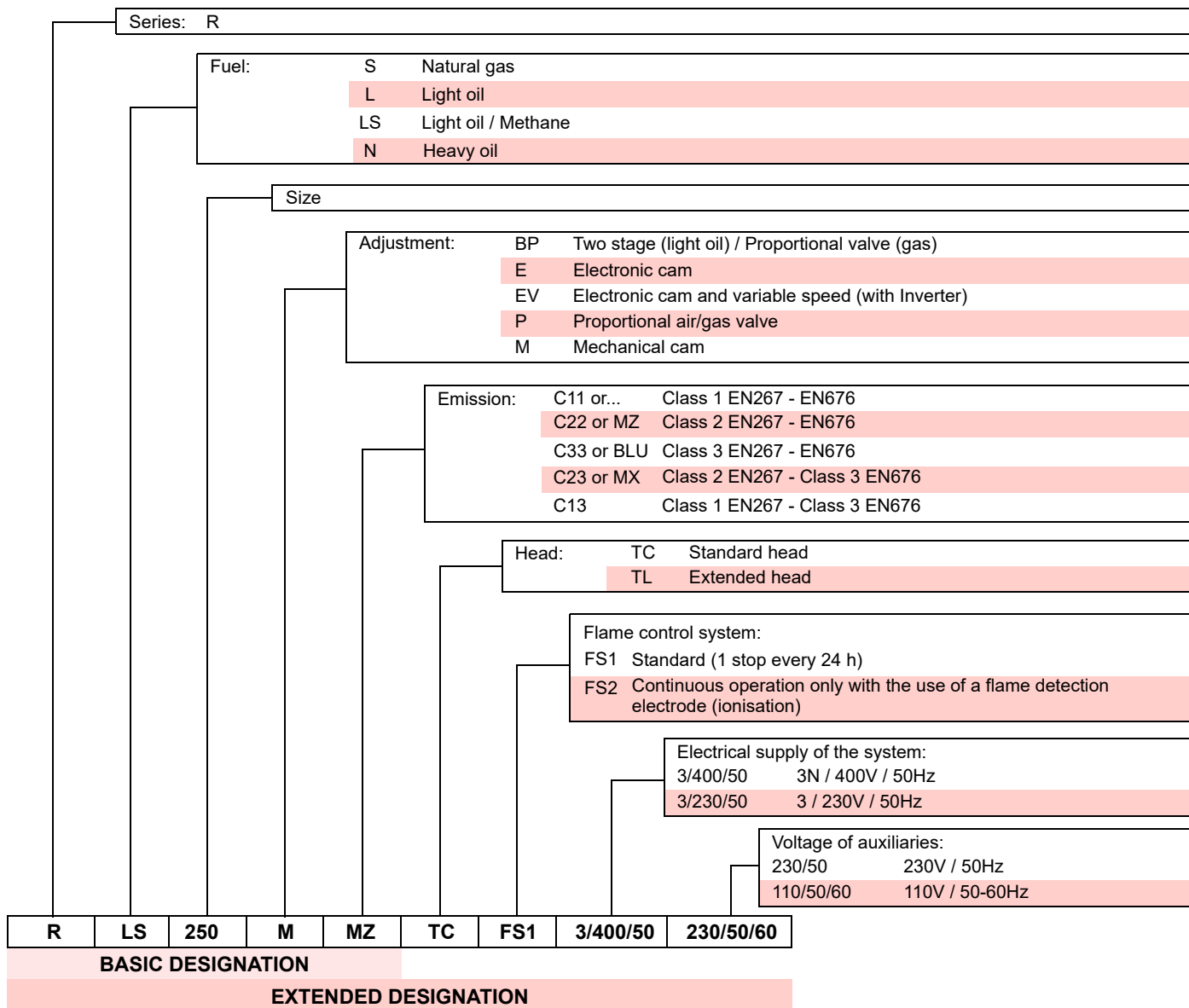

3.2 Models available

Designation	Start-up	Code
RLS 250/M MZ TC 3 ~ 400V +/-10% 50 Hz	Direct	20205746
RLS 250/M MZ TL 3 ~ 400V +/-10% 50 Hz	Direct	20208628

3.3 Burner categories - Countries of destination

Gas category	Country of destination
I2H	AT- BG- CH- CZ- DK- EE- ES- FI- GB- GR- HU- IE- IS- IT- LT- LV- NO- PT- RO- SE- SI- SK- TR
I2E(R)	BE
I2E	LU- PL
I2ELL	DE
I2EK	NL
I2Er	FR

3.4 Technical data

Model			RLS 250/M MZ
Type			1302 T
Output ⁽¹⁾ Delivery ⁽¹⁾	2nd stage min - max	kW kg/h	1230 ÷ 2460 104 ÷ 207
	1st stage min	kW kg/h	550 47.5
Fuels			<ul style="list-style-type: none"> - LIGHT OIL, max. viscosity at 20 °C: 6 mm²/s (1.5 °E - 6 cSt) - NATURAL GAS: G20 (methane gas) - G25
Operation			<ul style="list-style-type: none"> - FS1: Intermittent (min. 1 stop in 24 hours) - Oil: two-stage (high and low flame) and one-stage (all - nothing) - Gas: progressive two-stage or modulating by kit (see accessories)
Pump	Output at 12 bar	kg/h	230
	Pressure range	bar	10 - 21
	Fuel temperature	°C max	90
Nozzles		number	2
Standard applications			Boilers: water, steam, diathermic oil
Ambient temperature		°C	0 - 40
Combustion air temperature		°C max	60
Noise levels ⁽²⁾	Sound pressure	dB(A)	85
	Sound power		96
Weight		Kg	95-97
EC		Nr.	CE-0476DQ3601

Tab. A

- (1) Reference conditions: Ambient temperature 20°C - Gas temperature 15°C - Barometric pressure 1013 mbar - Altitude 0 m a.s.l.
 (2) Sound pressure measured in manufacturer's combustion laboratory, with burner operating on test boiler and at maximum output. The sound power is measured using the "Free Field" method, required by the EN 15036 standard, and according to an "Accuracy: Category 3" measurement, as described in EN ISO 3746.

3.5 Electrical data

Model			RLS 250/M MZ
Electric power supply			3~ 400V +/-10% 50 Hz
Auxiliary circuit electrical supply			1N ~ 230V +/-10% 50 Hz
Absorbed electric power	kW max (light oil)		7.1
	kW max (gas)		6.5
Protection level			IP 44

Tab. B

3.6 Maximum dimensions

The dimensions of the burner are given in Fig. 1.

Bear in mind that inspection of the combustion head requires the burner to be opened and the rear part turned on the hinge.

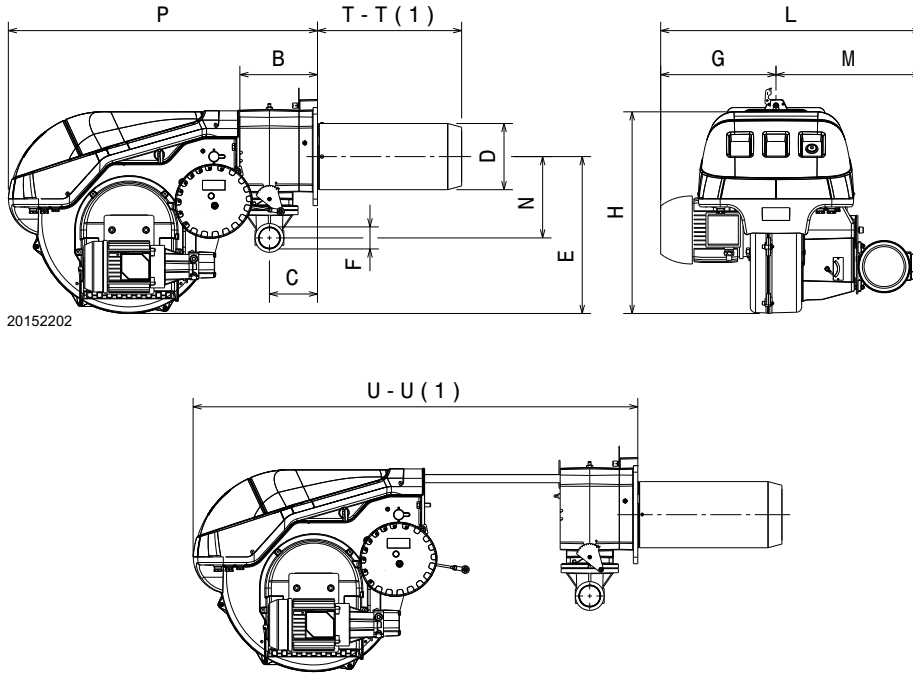

Fig. 1

mm	B	C	D	E	F	G	H	L	M	N	P	T-T (1)	U-U (1)
RLS 250/M MZ	229	141	Ø 222	436	Rp2"	426	555	902	476	261	863	420 - 550	1442 - 1587

Tab. C

(1) Blast tube: short-long

3.7 Firing rates

The **MAXIMUM OUTPUT** is to be chosen within area A of the diagram (Fig. 2).

The **MINIMUM OUTPUT** must not be lower than the minimum limit of the diagram:

RLS 250/M MZ = 550 kW



The firing rate value (Fig. 2) has been obtained considering an ambient temperature of 20 °C, an atmospheric pressure of 1013 mbar (approx. 0 m a.s.l.), and with the combustion head adjusted as shown on page 24.

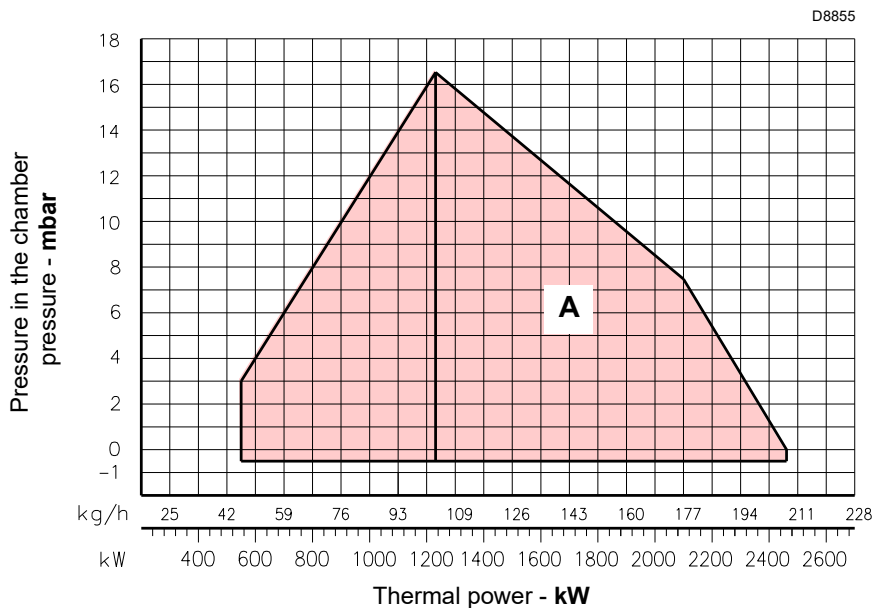

Fig. 2

3.8 Test boiler

The burner/boiler combination does not pose any problems if the boiler is EC approved and its combustion chamber dimensions are similar to those indicated in the diagram (Fig. 3).

If the burner must be combined with a boiler that has not been EC approved and/or its combustion chamber dimensions are clearly smaller than those indicated in the diagram (Fig. 3), consult the manufacturer.

The firing rates were obtained in special test boilers, according to EN 676 standard.

In Fig. 3 you can see the diameter and length of the test combustion chamber.

Example:
Output 650 Mcal/h
diameter 60 cm
length 2 m

MODULATING RATIO

The modulating ratio, obtained in the test boilers, according to standard (EN 676 for gas, EN 267 for light oil), is of:

- 4 : 1 (gas);
- 2 : 1 (light oil).

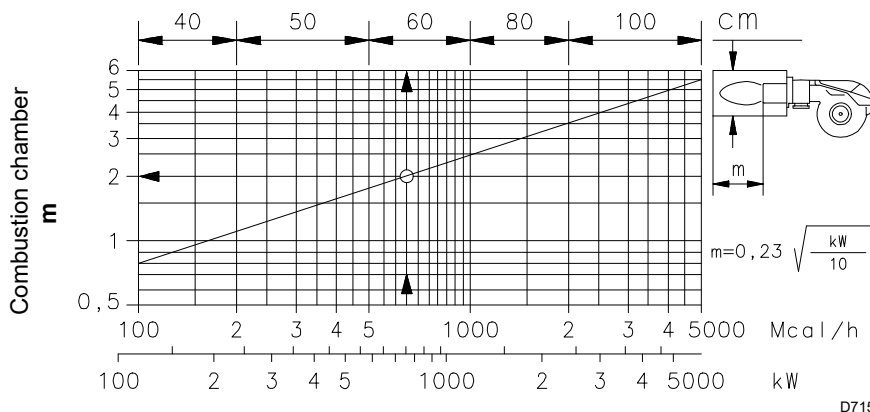

Fig. 3

3.9 Commercial boiler

The burner RLS 250/M MZ is suitable for operating on boilers with combustion chamber with bottom outflow (three passes), on which the best NO_x emissions are obtained.

The boiler front door maximum thickness must not exceed 250 mm (Fig. 4).

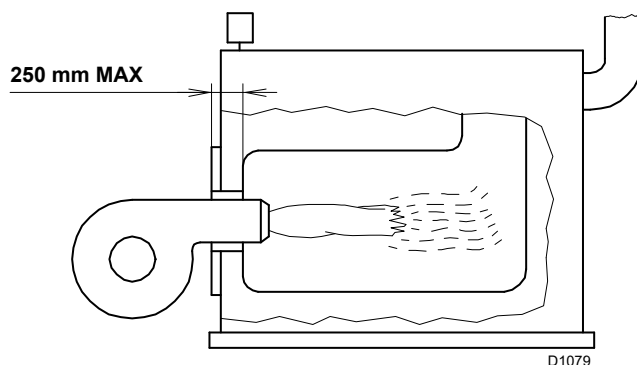

Fig. 4

3.10 Burner equipment

- Flange for gas train No. 1
- Seal for flange No. 1
- Screws to fix the flange M 10 x 40 to the gas butterfly valve No. 4
- Thermal flange gasket No. 1
- Screws to fix the burner flange pipe coupling to the boiler: M 16 x 40 No. 4
- Flexible hoses No. 2
- Nipples for flexible hoses with gaskets No. 2
- Instruction No. 1
- Spare parts list No. 1



It is recommended to tighten the screws of the gas flange with a tightening torque of **30 Nm ±10%**.

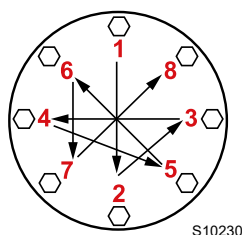

Tighten the nuts gradually (first to 30%, then to 60% up to 100%) according to the cross pattern shown in the figure.

3.11 Burner description

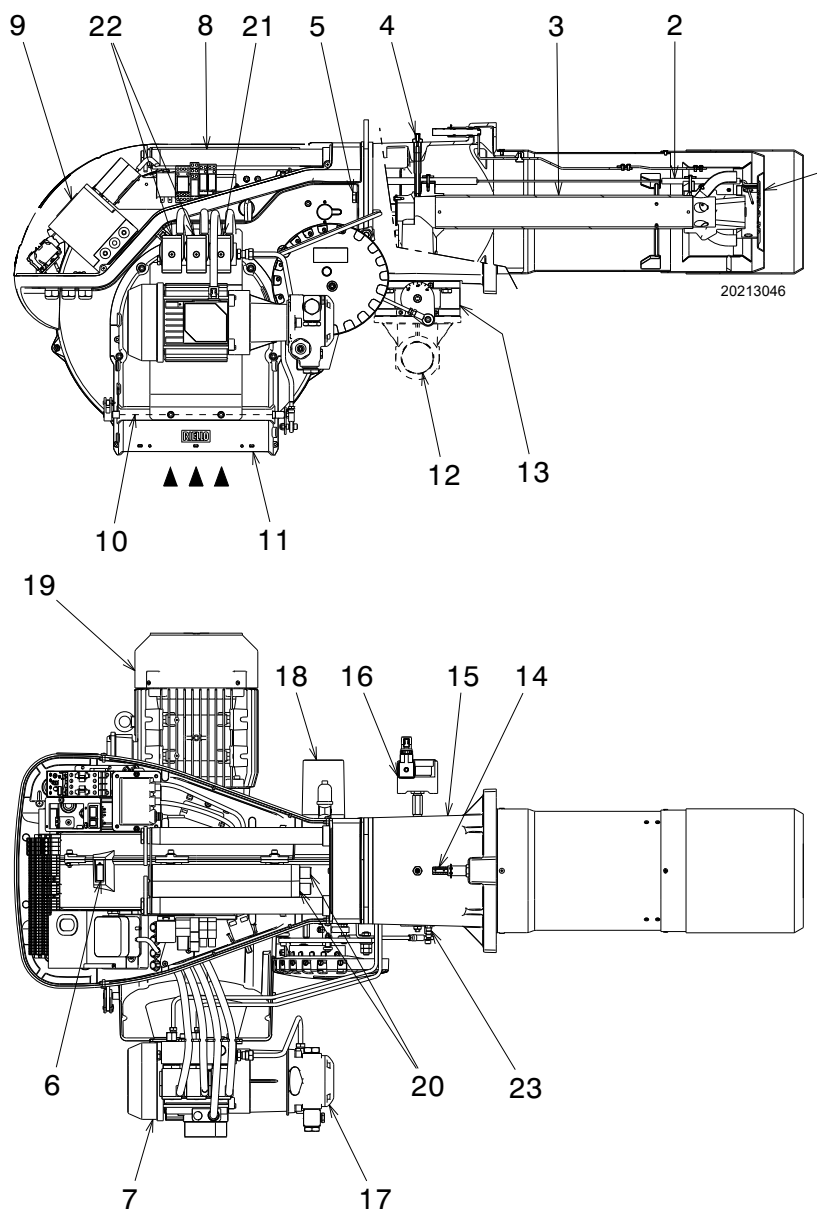

Fig. 5

- | | |
|---|---|
| <ul style="list-style-type: none"> 1 Flame stability disc 2 Ignition electrodes 3 Combustion head 4 Gas pressure test point and head fixing screw 5 Screws to secure fan to pipe coupling 6 Flame inspection window 7 Pump motor 8 Slide bars for opening the burner and inspecting the combustion head 9 Electrical flame control with lockout pilot light and reset button 10 Air damper 11 Air inlet to fan 12 Gas input pipework 13 Gas butterfly valve 14 Screw for combustion head adjustment 15 Sleeve with flange for securing the burner to the boiler 16 Maximum gas pressure switch 17 Pump | <ul style="list-style-type: none"> 18 Servomotor controlling the gas butterfly valve and the air damper, by means of a variable profile cam mechanism. When the burner is not operating the air damper is fully closed in order to reduce heat dispersion from the boiler due to the flue draught, which draws air from the fan suction inlet. 19 Fan motor 20 Extensions for slide bars 8) 21 Safety valve 22 1st and 2nd stage valve 23 Air pressure test point |
|---|---|

3.12 Electrical panel description

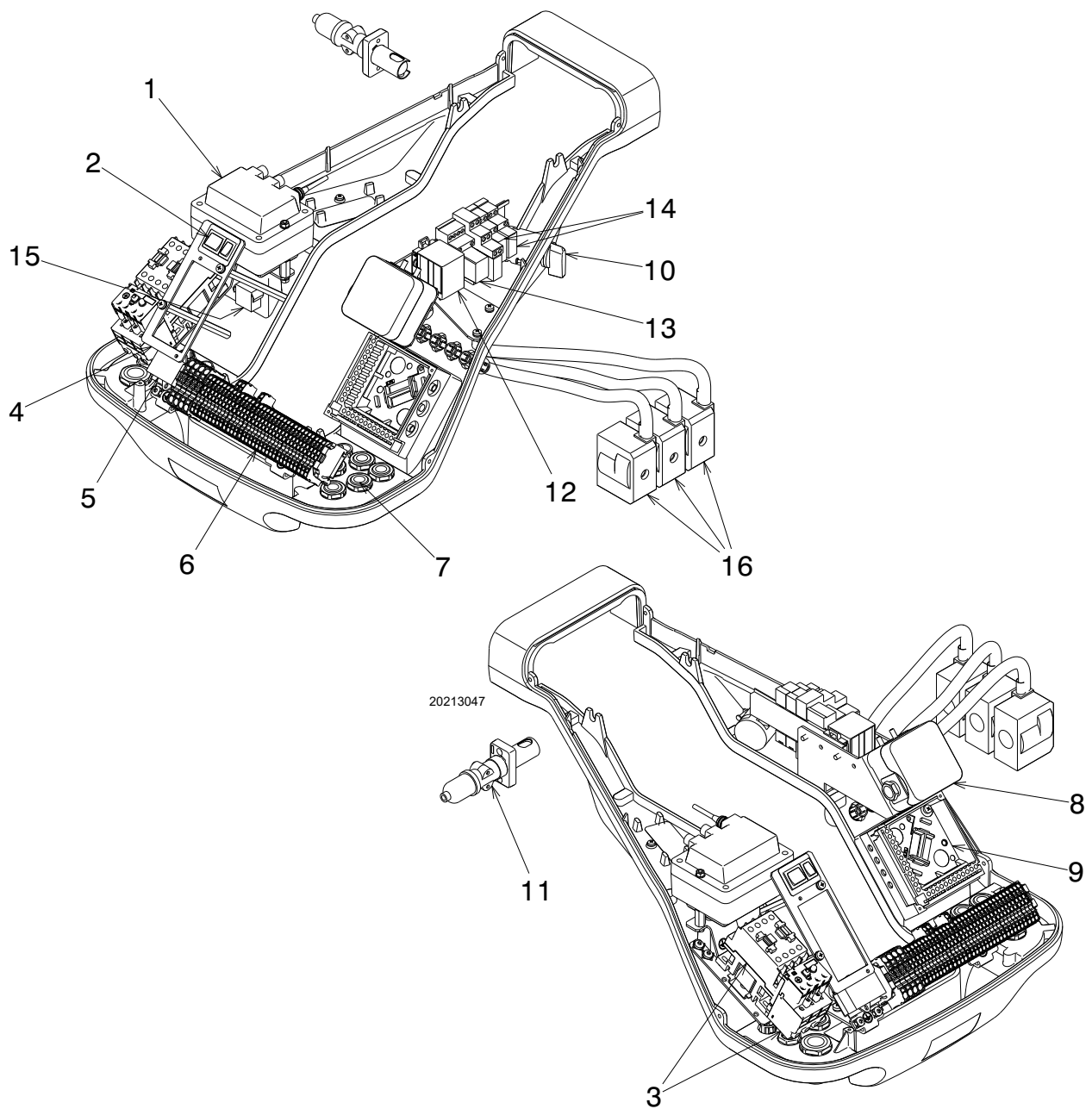

Fig. 6

- | | |
|--|---|
| <ul style="list-style-type: none"> 1 Ignition transformer 2 Switch for:
for automatic-manual-off operation
Switch for:
output increase-decrease 3 Motor contactor and thermal relay with reset button 4 Bracket for RWF kit application 5 Protection against radio interference 6 Terminal board for electrical connection 7 Cable-grommets for external connections to be carried out
by the installer 8 Air pressure switch (differential type) 9 Flame control base 10 Oil- gas switch 11 Flame sensor 12 Output relay 13 Relay 14 Clean contacts relay | <ul style="list-style-type: none"> 15 Plug for the connection of the RWF kit for modulating operation 16 Coils for oil valves |
|--|---|

3.13 Flame control (LFL...)

Important notes



ATTENTION

To avoid accidents, material or environmental damage, observe the following instructions!

The flame control LFL1... is a safety device! Avoid opening or modifying it, or forcing its operation. Riello S.p.A. cannot assume any responsibility for damage resulting from unauthorised interventions!

- All interventions (assembly and installation operations, assistance, etc.) must be carried out by qualified personnel.
- Before modifying the wiring in the LFL1... flame control connection area, fully disconnect the system from the power supply (omnipolar separation).
- Protection against electrocution from the flame control and all connected electric components is obtained with the correct assembly.
- Before any intervention (assembly and installation operations, assistance, etc.), ensure the wiring is in order and that the parameters are correctly set, then make the safety checks.
- Falls and collisions can negatively affect the safety functions. In this case, the flame control must not be operated, even if it displays no evident damage.
- **Do not press the reset button or the remote reset button of the flame control for more than 10 seconds because this will damage the internal relay.**

For safety and reliability, comply with the following instructions:

- Avoid conditions that can favour the development of condensate and humidity. Otherwise, before switching on again, make sure that the entire flame control is perfectly dry!
- Static charges must be avoided since they can damage the flame control's electronic components when touched.

Use

The LFL1... flame control is a control and supervision system of medium and large capacity forced draft burners for intermittent operation (at least one controlled shutdown every 24 hours).

Installation notes

- Check the electrical wiring inside the boiler complies with the national and local safety regulations.
- Do not confuse the powered conductors with the neutral ones.
- Ensure that spliced wires cannot get into contact with neighbouring terminals. Use adequate ferrules.
- Arrange the H.V. ignition cables separately, as far as possible from the flame control and the other cables.
- When wiring the unit, make sure that AC 230 V mains voltage cables are run strictly separate from extra low-voltage cables to avoid risks of electrical shock hazard.

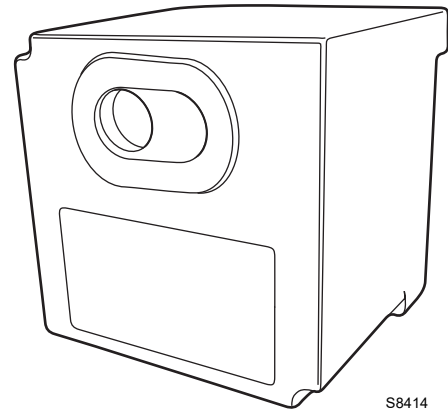

S8414

Fig. 7

Electrical wiring of the flame detector

It is important for signal transmission to be almost totally free of any disturbances or loss:

- Always separate the detector cables from the other cables:
 - The capacitive reactance of the line reduces the size of the flame signal.
 - Use a separate cable.
- Respect the allowed cable lengths.
- The ionisation probe is not protected against the risk of electrocution. When connected to the electricity supply, the ionisation probe must be protected against any accidental contact.
- Position the ignition electrode and the ionisation probe so that the ignition spark cannot form an arc on the probe (risk of electric overcharge).

Technical data

Mains voltage	AC 230 V -15 % / +10 %
Mains frequency	50 / 60 Hz ±6 %
Fuse (Internal)	T6.3H250V
Primary fuse (external)	max. 10 A
Weight	approx. 1 kg
Power absorption	approx. AC 3.5 VA
Protection level	IP40
Safety class	II
Input current at terminal 1	max. 5 A continuous (peaks of 20 A / 20 ms)
Load on the control terminals	max. 4 A continuous (peaks of 20 A / 20 ms)
Environmental conditions	
Operation	DIN EN 60721-3-1
Climatic conditions	Class 1K3
Mechanical conditions	Class 1M2
Temperature range	-20...+60°C
Humidity	< 95% RH

Tab. D

3.14 Servomotor (SQN31...)

Important notes



To avoid accidents, material or environmental damage, observe the following instructions!

Avoid opening, modifying or forcing the actuators.

- All interventions (assembly and installation operations, assistance, etc.) must be carried out by qualified personnel.
- Before modifying the wiring in the connection area of the servomotor, fully disconnect the burner control device from the power supply (omnipolar separation).
- To avoid the risk of electrocution, protect the connection terminals in a suitable manner and correctly fix the cover.
- Check the wiring is in order.
- Falls and collisions can negatively affect the safety functions. In this case, the servomotor must not be operated, even if it displays no evident damage.

Assembly notes

- Check the relevant national safety standards are respected.
- When assembling the servomotor and connecting the damper, the gears can be disengaged by means of a lever, allowing the drive shaft to be easily adjusted in both directions of rotation.



Fig. 8

Technical data

Operating voltage	AC 220...240 V - 15% / +10% AC 100...110 V - 15% / +10%
Mains frequency	50...60 Hz ± 6%
Switching capacity of auxiliary devices and limit switches	10 (3) A, AC 24...250 V
Angle positioning	up to 160° (full scale)
Assembly position	option
Protection level	IP 54, DIN 40050
Safety class	I
Weight	approx. 0.8 kg
Actuator motor	synchronous motor
Power absorption	6.5 VA
Environmental conditions:	
Operation	DIN EN 60 721-3-1
Climatic conditions	Class 1K2
Mechanical conditions	Class 1M2
Temperature range	-20...+60°C
Humidity	< 95% RH

Tab. E

4 Installation

4.1 Notes on safety for the installation

After carefully cleaning all around the area where the burner is to be installed, and arranging for the environment to be illuminated correctly, proceed with the installation operations.



All the installation, maintenance and disassembly operations must be carried out with the electricity supply disconnected.



The installation of the burner must be carried out by qualified personnel, as indicated in this manual and in compliance with the standards and regulations of the laws in force.



The combustion air inside the boiler must be free from hazardous mixes (e.g.: chloride, fluoride, halogen); if present, it is highly recommended to carry out cleaning and maintenance more frequently.

4.2 Handling

The burner packaging includes a wooden platform, it is therefore possible to handle the burner (still packaged) with a pallet truck or fork lift truck.



Burner handling operations can be highly dangerous if not carried out with the greatest attention: distance unauthorised personnel, check integrity and suitability of the means available. Check also that the area in which you are working is empty and that there is an adequate escape area (i.e. a free, safe area to which you can quickly move if the burner should fall). When handling, keep the load at no more than 20-25 cm from the ground.



After positioning the burner near the installation point, correctly dispose of all residual packaging, separating the various types of material.



Before proceeding with the installation operations, carefully clean all around the area where the burner will be installed.

4.3 Preliminary checks

Checking the consignment



After removing all the packaging, check the integrity of the contents. In the event of doubt, do not use the burner; contact the supplier.



The packaging elements (wooden cage or cardboard box, nails, clips, plastic bags, etc.) must not be abandoned as they are potential sources of danger and pollution; they should be collected and disposed of in the appropriate places.

		A		B	
		D		C	
		E		F	
GAS-KAASU	<input checked="" type="checkbox"/> FAM.2	G		H	
GAZ-AEPIO	<input type="checkbox"/> FAM.3	G		H	
		I		I	
		L			
				CE	
					

20206732

Fig. 9

Checking the characteristics of the burner

Check the identification label of the burner, showing:

- the model (A)(Fig. 9) and type of burner (B);
- the year of manufacture, in cryptographic form (C);
- the serial number (D);
- the data for electrical supply and the protection level (E);
- the absorbed electrical power (F);
- the types of gas used and the relative supply pressures (G);
- the data of the burner's minimum and maximum output possibilities (H) (see Firing rate).

Warning. The burner output must be within the boiler's firing rate;

- category of the appliance/countries of destination (I).
- light oil maximum viscosity (L).



A burner label that has been tampered with, removed or is missing, along with anything else that prevents the definite identification of the burner makes any installation or maintenance work difficult

4.4 Preparing the boiler

4.4.1 Boring the boiler plate

Pierce the closing plate of the combustion chamber, as in Fig. 10. The position of the threaded holes can be marked using the thermal insulation screen supplied with the burner.

4.4.2 Blast tube length

The length of the blast tube must be selected according to the indications provided by the manufacturer of the boiler, and in any case it must be greater than the thickness of the boiler door complete with its fettling.

The range of lengths available, L (mm), is as follows:

- standard 418
- extended 548

For boilers with front flue passes 15)(Fig. 11) or flame inversion chamber, a protection in refractory material 13) must be inserted between the boiler fettling 14) and the blast tube 12).

This protection must not compromise the extraction of the blast tube.

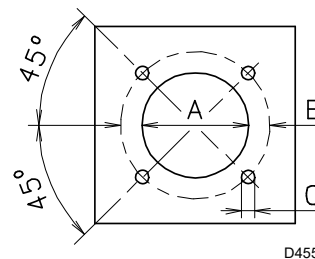

Fig. 10

mm	A	B	C
RLS 250/M MZ	230	325 - 368	M 16

Tab. F

4.5 Securing the burner to the boiler

Separate the combustion head from the rest of the burner, Fig. 11:

- disconnect the light oil pipes unscrewing the two fittings 6);
- disengage the articulated coupling 7) from the graduated sector 8);
- loosen the 4 screws 3) and remove the cover 1);
- remove screws 2) from the two slide bars 5);
- remove the two screws 4) and pull the burner back on slide bars 5) by about 100 mm;
- disconnect the electrode cables, then fully extract the burner from the slide bars;

- fix the pipe coupling with flange 11) to the boiler plate interposing the insulating gasket 9) supplied. Use the 4 screws, also supplied, after protecting their thread with anti-locking product.



The seal between burner and boiler must be airtight.

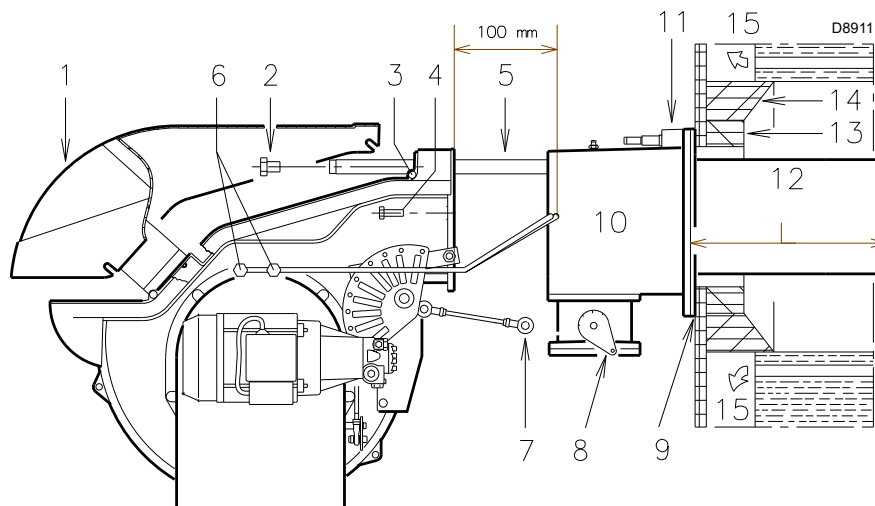

Fig. 11

4.5.1 Choice of nozzles for 1st and 2nd stage

Both nozzles must be chosen from among those listed in Tab. G.

- The first nozzle determines the delivery of the burner at the 1st stage.
- The second nozzle works together with the 1st nozzle to determine the delivery of the burner in the 2nd stage.

The deliveries of the 1st and 2nd stages have to be within the value range indicated on Tab. A.

Use nozzles with a 60° spray angle at the recommended pressure of 12 bar.

Generally the two nozzles have the same delivery, but the 1st stage nozzle can have a delivery that is 50% lower than the total

delivery. This is useful when you want to reduce the back pressure peak on ignition (the burner provides good combustion values even with 40-100% ratios between the 1st and 2nd stages).

Example:

boiler output = 1630 kW - yield 90%

power required by the burner = 1630 : 0.9 = 1812 kW;

1812 : 2 = 906 kW per nozzle

so two equal nozzles of 60°, 12 bar are required:

1st = 18 GPH - 2nd = 18 GPH,

or the following two different nozzles: 1st = 16 GPH - 2nd = 20 GPH.

4.6 Nozzle installation

The burner complies with the emission requirements of EN 267 standard.

In order to guarantee that emissions do not vary, recommended and/or alternative nozzles specified by Riello in the Instruction and warning booklet should be used.



ATTENTION

It is advisable to replace the nozzle once a year during periodical maintenance.



CAUTION

The use of nozzles other than those specified by Riello S.p.A. and inadequate regular maintenance may result into emission limits non-conforming to the values set forth by the regulations in force, and in extremely serious cases, into potential hazards to people and objects.

The manufacturing Company shall not be liable for any such damage arising from non-observance of the requirements contained in this manual.

Remove the screw 1)(Fig. 12) and extract the internal part 2)(Fig. 12).

Assemble the two nozzles with the socket spanner 1)(Fig. 13) (16 mm), after removing the plastic plugs 2)(Fig. 13), passing through the central opening of the flame stability disc. Alternatively, loosen the screws 1)(Fig. 14), remove the disc 2)(Fig. 14), and replace the nozzles using the spanner 3)(Fig. 14).



ATTENTION

- Do not use any sealing products such as: gaskets, tape or sealants.
- Be careful to avoid damaging the nozzle sealing seat.
- The nozzle must be screwed into place tightly but not to the maximum torque value provided by the wrench.

The nozzle for the 1st stage of operation is the one beneath the ignition electrodes, Fig. 16.

Check that the electrodes are placed as in Fig. 16.



ATTENTION

Position the ignition electrodes according to the dimensions shown in Fig. 12.

Refit the burner on the slide bars 3)(Fig. 15), approximately 100 mm from the pipe coupling 4)(Fig. 15) - burner in the position shown in Fig. 11 insert the electrode cables and then slide the burner up to the pipe coupling, burner in the position shown in Fig. 15.

Refit screws 2)(Fig. 15) on slide bars 3).

Fix the burner to the pipe coupling with the screws 1). Reconnect the light oil pipes by screwing the two fittings 6)(Fig. 11).

Reconnect the articulated coupling 7) to the graduated sector 5).



ATTENTION

On closing the burner on the two guides it is advisable to gently pull the high voltage wires outwards until they are under slight tension.

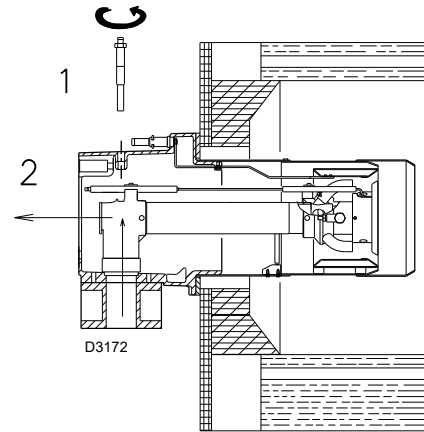

Fig. 12

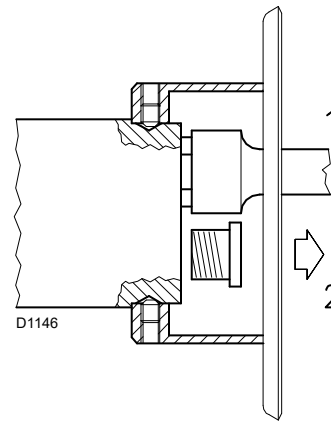

Fig. 13

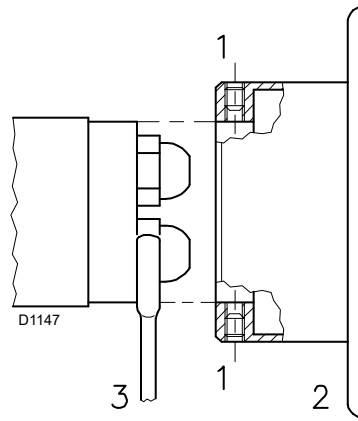

Fig. 14

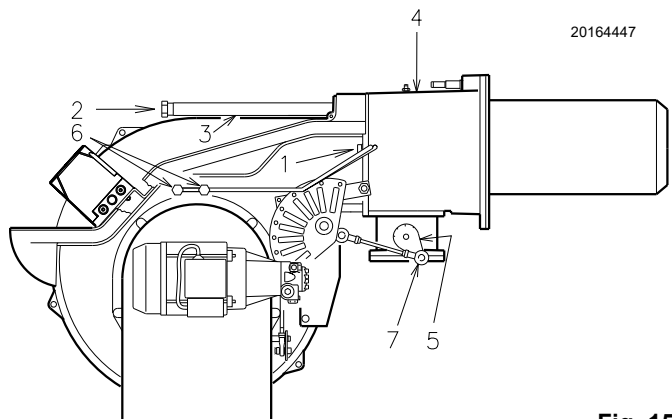

Fig. 15

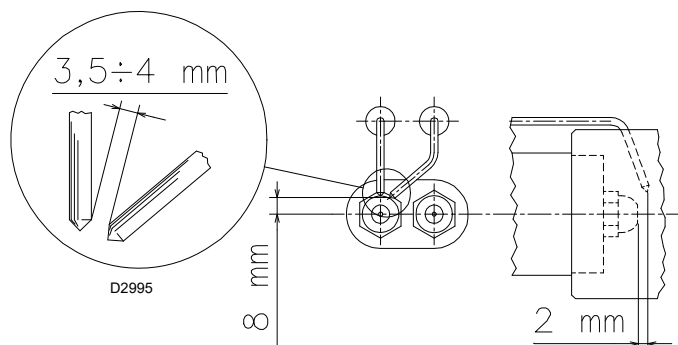

Fig. 16



ATTENTION

- Do not use any sealing products such as: gaskets, tape or sealants.
- Be careful to avoid damaging the nozzle sealing seat.
- The nozzle must be screwed into place tightly but not to the maximum torque value provided by the wrench.

Ugello tipo: DELAVAN B 60°				
GPH	kg/h			kW 12 bar
	10 bar	12 bar	14 bar	
12.0	44.16	48.73	52.96	582.36
13.0	47.84	52.79	57.38	630.89
14.0	51.52	56.86	61.79	679.42
15.0	55.20	60.92	66.20	727.95
16.0	58.88	64.98	70.62	776.48
17.0	62.57	69.04	75.03	825.01
18.0	66.25	73.10	79.44	873.54
19.0	69.93	77.16	83.86	922.07
20.0	73.61	81.22	88.27	970.60
22.0	80.97	89.34	97.10	1067.66
24.0	88.33	97.47	105.93	1164.72
25.0	92.00	101.53	110.34	1198.00
26.0	95.69	105.59	114.75	1261.78
28.0	103.05	113.71	123.58	1358.84
30.0	110.41	121.83	132.41	1455.90
32.0	117.77	129.95	141.24	1533.47
34.0	125.13	138.08	150.06	1629.31
35.0	128.81	142.14	154.48	1667.23

Tab. G

4.7 Pump motor rotation

Refer to Fig. 17 for the pump motor rotation.

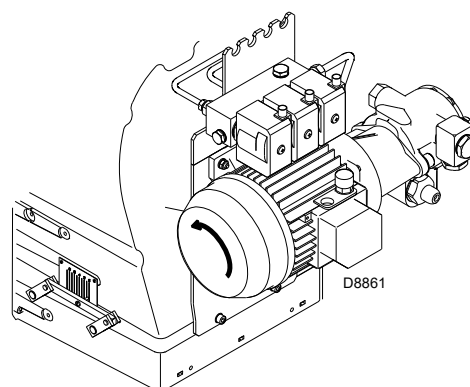

Fig. 17

4.8 Light oil supply



Explosion danger due to fuel leaks in the presence of a flammable source.

Precautions: avoid knocking, attrition, sparks and heat.

Make sure the fuel shut-off valve is closed before performing any operation on the burner.



ATTENTION

The fuel supply line must be installed by qualified personnel, in compliance with current standards and laws.

4.8.1 Double-pipe circuit

The burner is equipped with a self-priming pump which is capable of feeding itself within the limits listed in the table at the side.

Tank higher than burner A (Fig. 18)

Distance P must not exceed 10 meters in order to avoid straining the pump's seal; distance V must not exceed 4 meters in order to allow the self-priming of the pump even when the tank is almost empty.

Tank lower than burner B (Fig. 18)

The pump depression value must not exceed 0.45 bar (35 cm Hg). Because at higher levels gas is released from the fuel; the pump becomes noisy and its lifetime is shortened.

It is good practice to ensure that the return and suction lines enter the burner from the same height; the suction line is more difficult to disconnect.

Key (Fig. 18)

- H = Pump/Foot valve height difference
- L = Piping length
- ∅ = Inside pipe diameter
- 1 = Burner
- 2 = Pump
- 3 = Filter
- 4 = Manual on/off valve
- 5 = Suction line
- 6 = Foot valve
- 7 = Quick closing manual valve with remote control (Italy only)
- 8 = On/off solenoid valve (Italy only)
- 9 = Return line
- 10 = Check valve (Italy only)

4.8.2 Loop circuit

The loop circuit is composed of a duct starting from the tank and going back to it, in which an auxiliary pump makes the pressurised fuel flow.

A branch from the loop supplies the burner.

This circuit is extremely useful whenever the burner pump does not succeed in self-priming because the tank distance and/or height difference are higher than the values listed in the table.

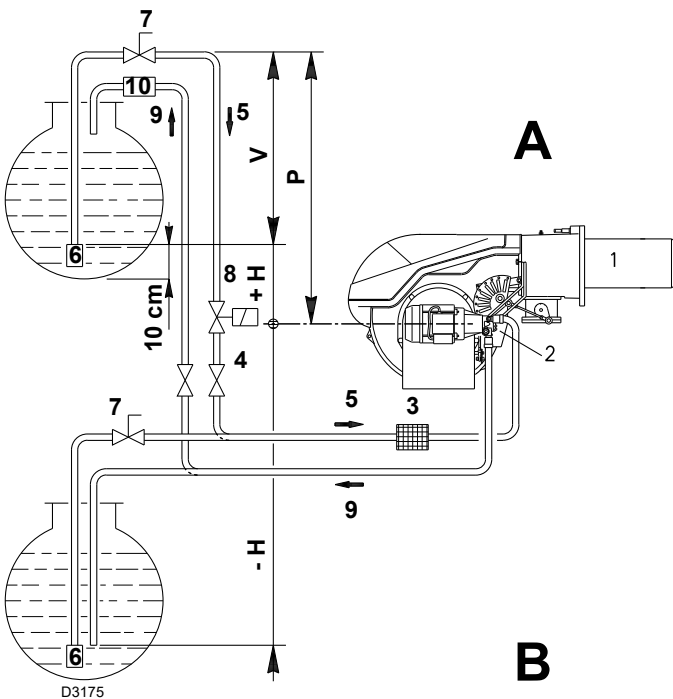

H (m)	L (m)		
	∅ (mm)		
	12	14	16
0	7	16	29
+ 0.5	8	18	33
+ 1	10	20	36
+ 2	12	24	43
+ 3	14	29	51
+ 4	16	33	58
0	7	16	29
- 0.5	6	14	25
- 1	5	12	22
- 2	3	7	15
- 3	-	3	7
- 4	-	-	-

Tab. H

Fig. 18

4.8.3 Hydraulic circuit diagram

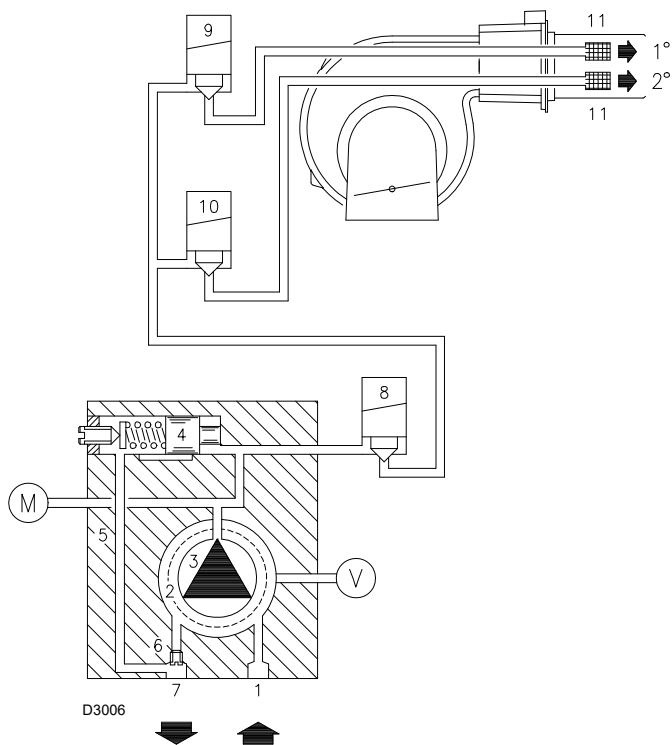

Fig. 19

Key (Fig. 19)

- | | |
|---------------------|--------------------|
| 1 Pump suction line | 8 Safety valve |
| 2 Filter | 9 1st stage valve |
| 3 Pump | 10 2nd stage valve |
| 4 Pressure adjuster | 11 Filter |
| 5 Return pipe | M Pressure gauge |
| 6 By-pass screw | V Vacuometer |
| 7 Pump return line | |

4.8.4 Hydraulic connections (Fig. 20)

The pumps are equipped with a by-pass that connects return line with suction line. They are installed on the burner with the by-pass closed by screw 6)(Fig. 21). It is therefore necessary to connect both hoses to the pump. The pump will break down immediately if it is run with the return line closed and the by-pass screw inserted.

Remove plugs from suction and return connectors of the pump. Insert the hose connections with the supplied seals into the connections and screw them down. During the installation, hoses must not be stressed with twisting.

Position hoses so that they cannot be stepped on or get into contact with hot parts of the boiler and so that they allow burner opening.

Connect, finally, the other end of the flexible hoses to the suction and return lines using nipples supplied with the equipment.

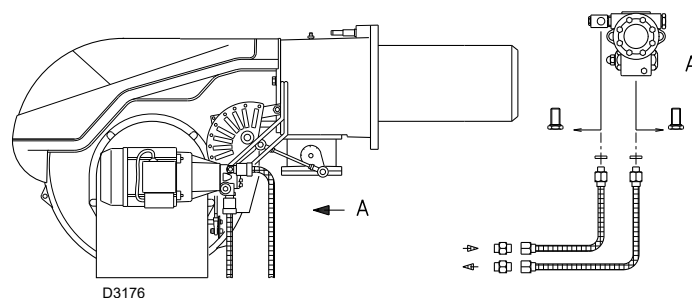

Fig. 20

4.8.5 Priming pump



ATTENTION

Before starting the burner, make sure that the tank return line is not clogged. Obstructions in the line could cause the sealing organ located on the pump shaft to break.

- Make sure that the valves on the suction line are open and that there is fuel in the tank.
- In order for self-priming to take place, the screw 3) of the pump must be loosened, see Fig. 21, to bleed off the air contained in the suction pipe.
- Start the burner by closing the remote controls, with the switch 1)(Fig. 25, on page 23) in "MAN" position and switch 10)(Fig. 6, on page 11) in "OIL" position.
- The pump can be considered primed when the light oil starts coming out of the screw 3)(Fig. 21). Stop the burner: set switch 1)(Fig. 25, on page 23) to "OFF" and tighten the screw 3).

The time required for this operation depends upon the diameter and length of the suction tubing. If the pump fails to prime at the first starting of the burner and the burner locks out, wait approx. 15 seconds, reset the burner, and then repeat the starting operation as often as required. And so on. After 5 or 6 starting operations allow 2 or 3 minutes for the transformer to cool. Do not light the flame sensor in order to prevent the burner lockout; the burner locks out in any case about ten second after its start.



ATTENTION

The a.m. operation is possible because the pump is already full of fuel when it leaves the factory. If the pump has been drained, fill it with fuel through the opening on the vacuum meter prior to starting; otherwise, the pump will seize. Whenever the length of the suction piping exceeds 20-30 meters, the supply line must be filled using a separate pump.

4.8.6 Suntec J7 C pump

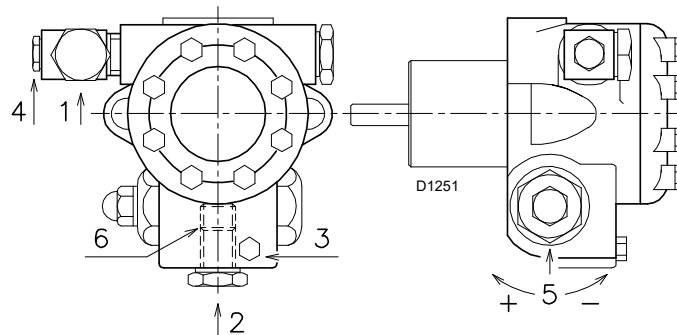

Fig. 21

Key (Fig. 21)

- | | |
|-----------------------------|--------|
| 1 Suction line | G 1/2" |
| 2 Return line | G 1/2" |
| 3 Pressure gauge connection | G 1/8" |
| 4 Vacuometer connection | G 1/8" |
| 5 Pressure adjuster | |
| 6 By-pass screw | |

Min. delivery rate at 12 bar pressure	230 kg/h
Delivery pressure range	10 - 21 bar
Max. suction depression	0.45 bar
Viscosity range	2.8 - 200 cSt
Max. light oil temperature	90 °C
Max. suction and return pressure	1.5 bar
Pressure calibration in the factory	12 bar
Filter mesh width	0,170 mm

Tab. I

4.9 Gas supply



Explosion danger due to fuel leaks in the presence of a flammable source.

Precautions: avoid knocking, attrition, sparks and heat.

Make sure the fuel shut-off valve is closed before performing any operation on the burner.



The fuel supply line must be installed by qualified personnel, in compliance with current standards and laws.

4.9.1 Gas feeding line (Example) - Please refer to the gas train documentation for more information

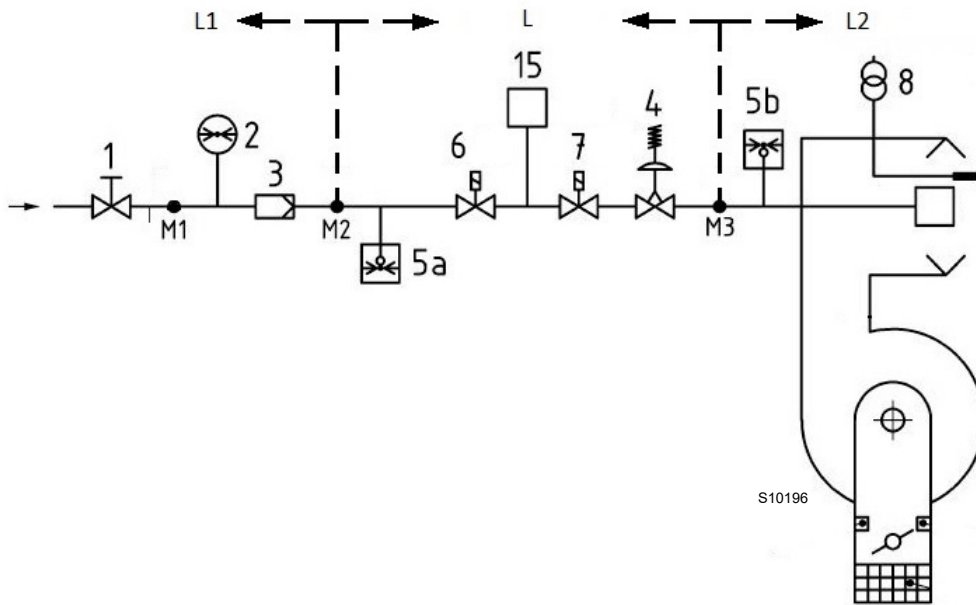

Fig. 22

Key (Fig. 22)

- 1 Manually operated shut-off valve
- 2 Pressure gauge
- 3 Filter
- 4 Governor
- 5a Low pressure protection device
- 5b Maximum gas pressure switch
- 6 1st safety shut-off device
- 7 2nd safety shut-off device
- 8 Ignition device
- 15 Valve leak detection control system
- L Gas train (supplied separately)
- L1 Responsibility of the installer
- L2 Burner
- M1 Pressure test point
- M2 Pressure test point
- M3 Pressure test point

4.9.2 Gas train

Type-approved in accordance with EN 676 and supplied separately from the burner.

4.9.3 Gas train installation



Disconnect the electrical power supply using the system main switch.



Check that there are no gas leaks.



Pay attention when handling the train: danger of crushing of limbs.



Make sure that the gas train is properly installed by checking for any fuel leaks.



The operator must use the required equipment during installation.

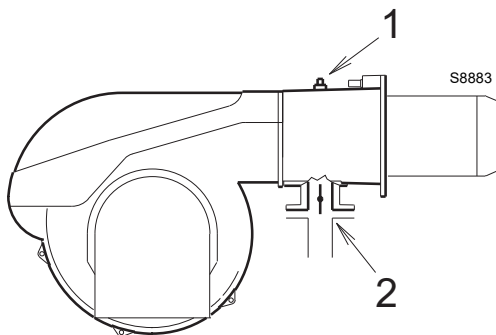

Fig. 23

4.9.4 Gas pressure

The adjacent Tab. J indicates the minimum pressure drops along the gas supply line, depending on the maximum burner output.

Combustion head pressure drop.

Gas pressure measured at test point 1)(Fig. 23), with:

- combustion chamber at 0 mbar;
- combustion head adjusted as in the diagram.

kW	Δp (mbar)		
	G20	G25	G31
1230	10.4	15.6	14
1367	13	19.4	17.4
1503	15.6	23.3	20.9
1640	18.3	27.3	24.5
1777	21.1	31.5	28.3
1913	24	35.8	32.2
2050	27	40.3	36.3
2187	30.1	44.9	40.5
2323	33.3	49.7	44.9
2460	36.6	54.6	49.3

Tab. J

Calculate the approximate maximum output of the burner in this way:

- subtract the combustion chamber pressure from the gas pressure measured at test point 1)(Fig. 23);
- find in Tab. J the pressure value closest to the result of the subtraction.

Read the corresponding output on the left.

Example:

Maximum output operation
Natural gas G 20 NCV 10 kWh/Nm³

$$\begin{aligned} \text{Gas pressure at test point 1)(Fig. 23)} &= 30 \text{ mbar} \\ \text{Pressure in combustion chamber} &= 3 \text{ mbar} \\ 30 - 3 &= 27 \text{ mbar} \end{aligned}$$

A pressure of 27.0 mbar corresponds in Tab. J to an output of 2050 kW.

This value serves as a rough guide; the effective output must be measured at the gas meter.

To calculate the required gas pressure at test point 1)(Fig. 23), set the maximum output required from the burner operation:

Find in Tab. J the output value closest to the desired value.

Read, on the right, the pressure at test point 1)(Fig. 23).

Add this value to the estimated pressure in combustion chamber.

Example:

Required burner maximum output operation: 2050 kW
Natural gas G 20 NCV 10 kWh/Nm³

$$\begin{aligned} \text{Gas pressure at an output of 2050 kW,} &= 27 \text{ mbar} \\ \text{from Tab. J} & \\ \text{Pressure in combustion chamber} &= 3 \text{ mbar} \\ 27 + 3 &= 30 \text{ mbar} \end{aligned}$$

pressure required at test point 1)(Fig. 23).



Data of head thermal power and gas pressure refer to operation with gas butterfly valve fully open (90°).

4.10 Electrical wiring

Notes on safety for the electrical wiring



- The electrical wiring must be carried out with the electrical supply disconnected.
- Electrical wiring must be made in accordance with the regulations currently in force in the country of destination and by qualified personnel. Refer to the wiring diagrams.
- The manufacturer declines all responsibility for modifications or connections different from those shown in the wiring diagrams.
- Check that the electrical supply of the burner corresponds to that shown on the identification label and in this manual.
- The burner has been type-approved for intermittent use. This means they should compulsorily be stopped at least once every 24 hours to enable the flame control to perform checks of its own start-up efficiency. Normally, burner stopping is guaranteed by the boiler's thermostat/pressure switch.
- If this is not the case, a time switch should be fitted in series to TL to stop the burner at least once every 24 hours. Refer to the wiring diagrams.
- The electrical safety of the device is obtained only when it is correctly connected to an efficient earthing system, made according to current standards. It is necessary to check this fundamental safety requirement. In the event of doubt, have the electrical system checked by qualified personnel. Do not use the gas tubes as an earthing system for electrical devices.
- The electrical system must be suitable for the maximum power absorption of the device, as indicated on the label and in the manual, checking in particular that the section of the cables is suitable for that level of power absorption.
- For the main power supply of the device from the electricity mains:
 - do not use adapters, multiple sockets or extensions;
 - make provisions for an omnipolar switch with a gap between the contacts of at least 3 mm (over-voltage category III), as required by current safety regulations.
- Do not touch the device with wet or damp body parts and/or in bare feet.
- Do not pull the electric cables.

Before carrying out any maintenance, cleaning or checking operations:



Disconnect the electrical supply from the burner by means of the system main switch.



Close the fuel shut-off valve.



Avoid condensate, ice and water leaks from forming.

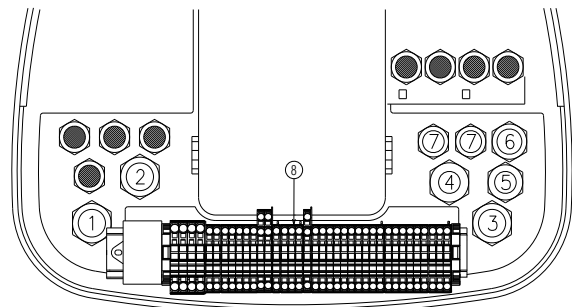

20160036

Fig. 24

If the cover is still present, remove it and proceed with the electrical wiring according to the wiring diagrams.

Use flexible cables according to EN 60 335-1 standard.



After carrying out maintenance, cleaning or checking operations, reassemble the cover and all the safety and protection devices of the burner.

4.10.1 Supply cables and external connections passage

All the cables to be connected to the burner terminal strip 8) should be routed through cable grommets. The use of the cable grommets can be done in different manners; for example, see Fig. 24.

Key (Fig. 24)

- 1 M25 three-phase power supply
- 2 M20 single-phase power supply
- 3 M20 TL control device
- 4 M20 TR control device
- 5 M20 Gas valves
- 6 M20 Gas pressure switch or valve leak detection device
- 7 Available

4.11 Calibration of the thermal relay

The thermal relay serves to avoid damage to the motor due to an excessive absorption increase or if a phase is missing.

For calibration **2)**, refer to the table indicated in the electrical layout (electrical wiring in charge of the installer).

To reset, in case of thermal relay activation, press the "RESET" button **1)**.

The button "STOP" **3)** opens the NC contact (95-96) and stops the motor.

Insert a screwdriver in the window "TEST/TRIP" **4)** and move it in the arrow direction (to the right) to carry out the thermal relay test.

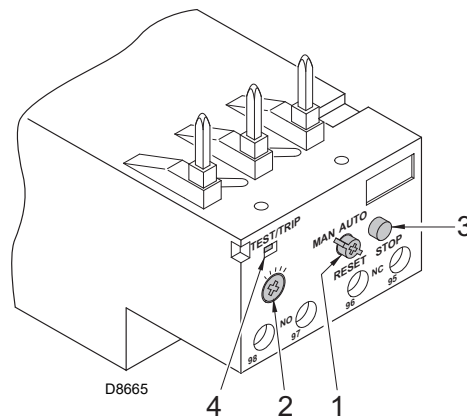

Fig. 25



The automatic reset can be dangerous.

This operation is not foreseen in the burner operation.



In the event the burner stops, in order to prevent any damage to the installation, do not unblock the burner more than twice in a row. If the burner locks out for a third time, contact the customer service.

4.12 Motor rotation

As soon as the burner starts, place yourself in front of the cooling fan of the fan motor and check that it turns anticlockwise (Fig. 26).

If this is not the case:

- put the switch of the burner to "0" (off) and wait until the flame control carries out the switching off phase.



Disconnect the electrical supply from the burner by means of the system main switch.

- Invert the phases on the three-phase motor power supply.

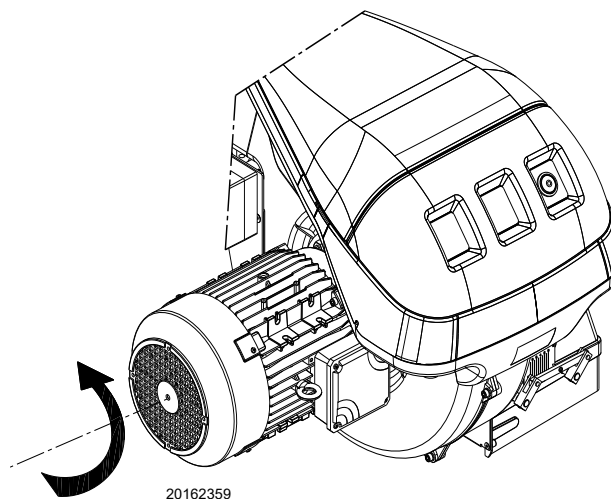

Fig. 26

5 Start-up, calibration and operation of the burner

5.1 Notes on safety for the first start-up



The first start-up of the burner must be carried out by qualified personnel, as indicated in this manual and in compliance with the standards and regulations of the laws in force.



Check the correct working of the adjustment, command and safety devices.



Before starting up the burner, refer to section "Safety test - with no gas supply" on page 31.

5.2 Adjustments prior to ignition (light oil)

5.2.1 Combustion head adjustment

The adjustment of the combustion head depends only on the maximum output of the burner. Turn the screw 5)(Fig. 27) until the notch indicated in diagram (Fig. 28) corresponds with the front part of the flange 6)(Fig. 27).



To facilitate the adjustment, loosen the screw 1)(Fig. 27), adjust, then block.

Example: Burner RLS 250/M MZ

Burner maximum output = 1500 kW

The diagram (Fig. 28) shows that for this output, the adjustment of the combustion head should be carried out on notch 5, as in Fig. 27.

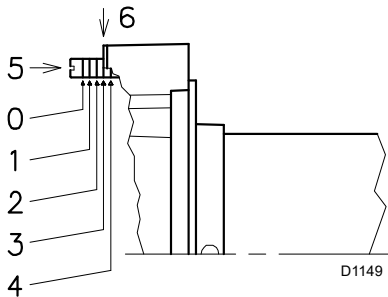

Fig. 27

5.2.2 Pump adjustment

No adjustment of gas delivery is required.

The pump leaves the factory set at 12 bar, a pressure to be checked and eventually modified after the burner has been started. In this phase, therefore, limit to apply a pressure gauge on the specific pump connector.

5.2.3 Fan damper adjustment

For the initial ignition, leave the factory setting for the 1st and 2nd stages.

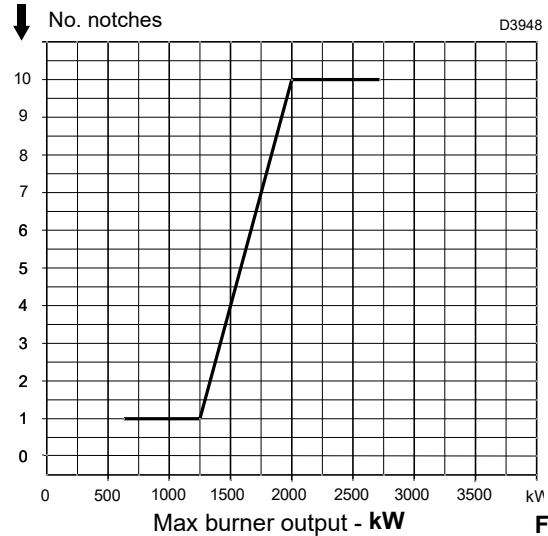

Fig. 28

5.3 Burner ignition (light oil)

Turn switch 1)(Fig. 29) to "MAN" position. During the first firing, during the passage from the 1st to the 2nd stage, there is a momentary lowering of the fuel pressure caused by the filling of the 2nd nozzle tubing. This lowering of the fuel pressure can cause the burner to lockout and can sometimes give rise to pulsations. Once the following adjustments have been made, the firing of the burner must generate a noise similar to the noise generated during operation.

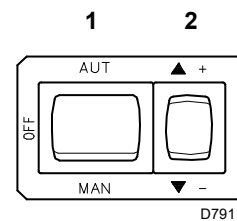

Fig. 29

5.4 Burner adjustment (light oil)



It is recommended to adjust first the light oil burner and then the gas burner. Carry out the fuel change with burner off.

5.5 Adjustments prior to ignition (gas)

Combustion head adjustment is already described on page 24.

In addition, the following adjustments must also be made:

- Open the manual valves upstream of the gas train.
- Adjust the minimum gas pressure switch to the start of the scale (Fig. 37, on page 29).
- Adjust the maximum gas pressure switch to the end of the scale (Fig. 36, on page 28).
- Adjust the air pressure switch to the start of the scale (Fig. 35, on page 28).
- Purge the air from the gas line. We recommend using a plastic tube routed outside the building and to purge air until gas is smelt.
- Fit a U-type pressure gauge (Fig. 30) to the gas pressure test point on the pipe coupling. The manometer readings are used to calculate MAX burner output using the Tab. J.
- Connect two lights or testers in parallel to the two gas line solenoid valves VR and VS in order to check the exact moment at which voltage arrives. This operation is not required if each of the two solenoid valves is equipped with a pilot light that signals voltage passing through.



Before starting up the burner, it is good practice to adjust the gas train so that ignition takes place in conditions of maximum safety, i.e. with gas delivery at the minimum.

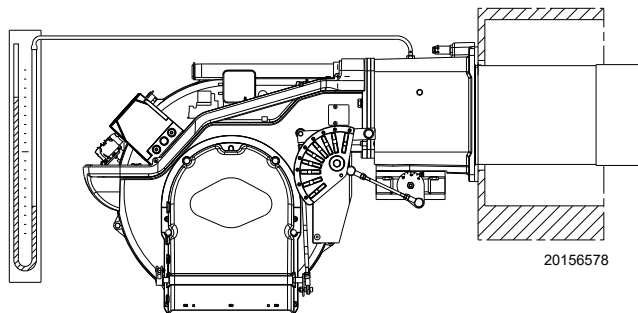

Fig. 30

5.6 Burner start-up

Feed electricity to the burner via the disconnecting switch on the boiler panel.

Close the thermostats/pressure switches and turn the switch in Fig. 31 to position “MAN”.

As soon as burner starts, check the fan rotation direction through the flame inspection window.



Check that the lamps or testers connected to the solenoid valves, or the pilot lights on the solenoid valves, indicate that no voltage is present. If they indicate the presence of voltage, stop the burner **immediately** and check the electric connections.

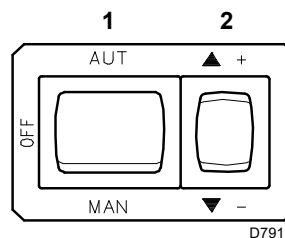

Fig. 31

5.7 Burner ignition

If the motor starts up, but the flame does not appear and the flame control goes into lockout, reset it and wait for a new ignition attempt.

If ignition is still not achieved, it may be that gas is not reaching the combustion head within the safety time period of 3 seconds. In this case, increase gas ignition delivery.

The arrival of gas to the sleeve is indicated by the U-type pressure gauge (Fig. 30).

Once ignition has taken place, proceed with burner global calibration operations.

5.7.1 Burner adjustment

The optimum adjustment of the burner requires an analysis of flue gases at the boiler outlet.

Adjust in sequence:

- 1 Ignition output
- 2 Maximum output
- 3 Minimum output
- 4 Intermediate outputs between the two
- 5 Air pressure switch
- 6 Maximum gas pressure switch
- 7 Minimum gas pressure switch

5.7.2 Ignition output



For safety purposes and correct product operation, the ignition output, if it is adjustable, must be carried out by authorized personnel and in compliance with the standards and regulations of the laws in force.

Air adjustment

The air is adjusted by changing the angle of cam III (Fig. 34, on page 27) and by using the selector 2 (Fig. 31). To adjust the cam of the servomotor, see Fig. 33.

5.7.3 Maximum output

The MAX output must be set within the firing rate indicated in Fig. 2, on page 8.

In the above instructions we left the burner running at the MIN output.

Now press the “increase output” button 2 (Fig. 31), and keep it pressed until the servomotor has opened the air damper and the gas butterfly valve.

Adjustment of gas delivery

Measure the gas delivery on the meter.

A rough indication can be obtained from Tab. J, on page 21, just read the gas pressure on the "U" pressure gauge (see Fig. 30, on page 25) and follow the indications.

- If delivery needs to be reduced, diminish outlet gas pressure; if it is already very low, slightly close the VR adjustment valve.
- If delivery needs to be increased, increase the adjuster outlet gas pressure.

Air adjustment

The air is adjusted by varying the angle of cam I) (Fig. 34, on page 27) and by using the selector 2)(Fig. 31, on page 25). To adjust the cam of the servomotor, see Fig. 33.

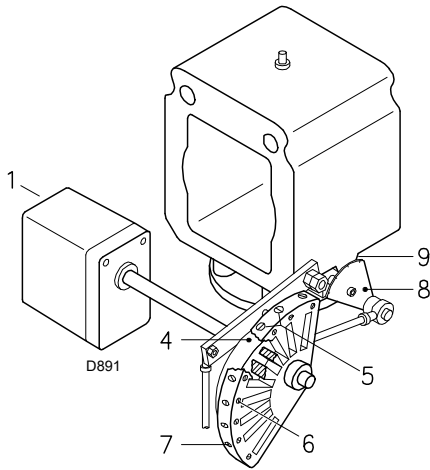

Fig. 32

Key (Fig. 32)

- 1 Servomotor
- 2 Servomotor 1) - cam 4): fastened
- 3 Servomotor 1) - cam 4): unfastened
- 4 Variable profile cam
- 5 Screws for adjusting the adjustable profile
- 6 Screws for fixing adjustment
- 7 Screws for adjusting the end profile
- 8 Gas butterfly valve graduated sector
- 9 Index of graduated sector 8

5.7.4 Minimum output

MIN output must be selected within the firing rate range indicated in Fig. 2, on page 8. Press button 2)(Fig. 31, on page 25) "Output decrease" and keep it pressed until the servomotor reaches (Fig. 33) the factory adjustment.

Air adjustment

Progressively adjust the end profile of the mechanical cam 4)(Fig. 32), using the screws 5)(Fig. 32).

For example, calibrate the minimum output to 800 kW, check the emissions and if necessary increase or decrease the opening of the air damper ("Air adjustment" on page 26).

Bring the output to 800 kW using the screws 5) of the mechanical cam (Fig. 32) and check the emissions.

Adjustment of gas delivery

The regulation of the air is carried out using the angle of the cam III) of the servomotor (Fig. 34, on page 27) and by using the selector 2)(Fig. 31, on page 25).

To adjust the cam of the servomotor, see Fig. 33).

NOTE:

The servomotor follows the adjustment of cam III) only when the angle of the cam is reduced. If it is necessary to increase the angle of the cam, you must first increase the angle of the servomotor by means of the "output increase" key, then increase the angle of cam III), and finally bring the servomotor to the position of MIN output, with the "Output reduction" key.

To adjust cam III, see Fig. 33, on page 26.

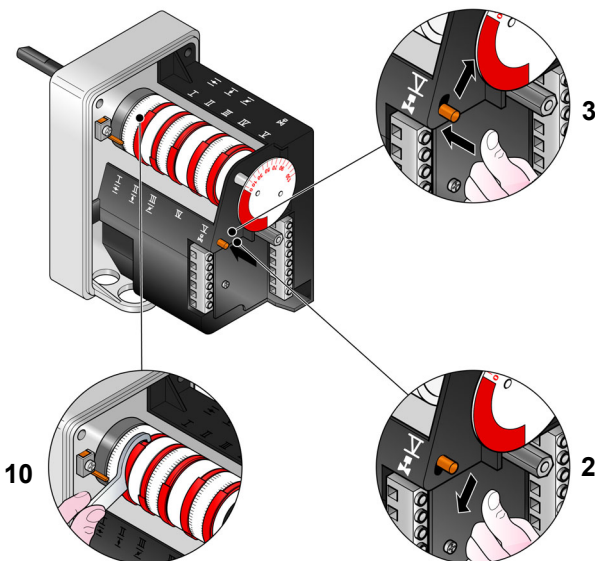

Fig. 33

5.7.5 Intermediate outputs

Adjustment of gas delivery

No adjustment is required

Air adjustment

After adjusting the maximum and minimum output of the burner, carry out air adjustment on higher intermediate positions of the servomotor.

The passage from one position to the next one is obtained by pressing the button 2) on the symbol (+) or (-) (Fig. 31, on page 25). Press button 2)(Fig. 31, on page 25) "Output increase" briefly so that the servomotor rotates by about 20°, see servomotor graduated index Fig. 33 and air damper graduated index 8)(Fig. 32 on page 26).

Screw or unscrew the screw 5) of the mechanical cam (Fig. 32, on page 26) to increase or decrease the gas output so as to adjust it to the corresponding air output, to obtain optimal combustion.

Proceed in the same way with the other screws.



ATTENTION

Take care that the cam profile variation is progressive.

Switch off the burner using switch 1)(Fig. 31, on page 25), OFF position, release the mechanical cam I) (Fig. 34, on page 27) to separate the gears of the servomotor, pressing and moving downwards button 3)(Fig. 33, on page 26), then manually rotate the mechanical cam I) (Fig. 33, on page 26) backwards and forwards a few times to check that the movement is smooth and without any hindrance.



ATTENTION

It is recommended that the mechanical cam 5)(Fig. 32 on page 26) be bound again to the servomotor by shifting button 3)(Fig. 33, on page 26) upwards.

As far as is possible, try not to move those screws at the ends of the mechanical cam that were previously adjusted for the opening of the gas butterfly valve to MAX and MIN output.

NOTE:

Once "MAX - MIN - INTERMEDIATE" outputs have been adjusted, recheck the ignition: its noise must be equal to the one of the following operation. If you notice any sign of pulsations, reduce the ignition stage delivery.

5.8 Servomotor adjustment

Important notes



ATTENTION

To avoid accidents, material or environmental damage, observe the following instructions!

Avoid opening, modifying or forcing the actuators.

- All interventions (assembly and installation operations, assistance, etc.) must be carried out by qualified personnel.
- Before modifying the wiring in the connection area of the servomotor, fully disconnect the burner control device from the power supply (omnipolar separation).
- To avoid the risk of electrocution, protect the connection terminals in a suitable manner and correctly fix the cover.
- Check the wiring is in order.
- Falls and collisions can negatively affect the safety functions. In this case, the servomotor must not be operated, even if it displays no evident damage.

Assembly notes

- Check the relevant national safety standards are respected.
- When assembling the servomotor and connecting the damper, the gears can be disengaged by means of a lever, allowing the drive shaft to be easily adjusted in both directions of rotation.

The servomotor provides simultaneous adjustment for the air damper, by means of the adjustable profile cam and the gas butterfly valve.

The servomotor rotates 130° in 42 s.

Do not alter the factory setting for the 5 cams; just check that they are as specified below:

Cam I:	130°	Limits rotation toward maximum position. When the burner is operating at MAX output, the gas butterfly valve must be fully open: 90°.
Cam II:	0°	Limits rotation toward minimum position. When the burner is shut down, the air damper and gas butterfly valve must be closed: 0°.
Cam III:	40° (gas)	Adjusts the ignition position and the MIN output.
Cam IV:	70° (oil)	Adjusts the ignition position and the output of the 1st stage.
Cam V:	100°	Determines when the 2nd stage light oil valve opens.

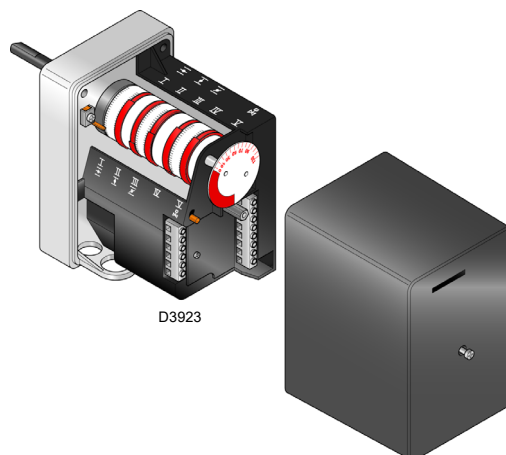

Fig. 34

5.9 Change of fuel

There is a change of fuel options:

- with selector 10)(Fig. 6 on page 11);



Change the fuel only when the burner is off.

5.10 Pressure switch adjustment

5.10.1 Air pressure switch - check CO

Adjust the air pressure switch after performing all other burner adjustments with the air pressure switch set to the start of the scale (Fig. 35).

With the burner operating in 1st stage, increase adjustment pressure by slowly turning the relevant knob clockwise until the burner locks out.

Then turn the knob counter-clockwise by about 20% of the set point and repeat burner start-up to ensure that it is correct.

If the burner locks out again, turn the knob slightly anticlockwise.

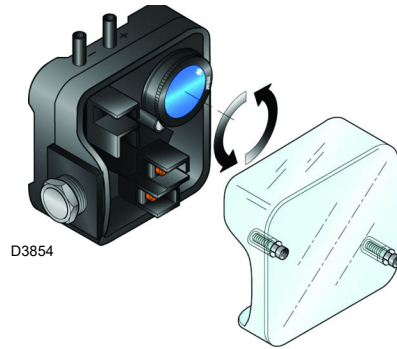

Fig. 35



In conformity with current standards, the air pressure switch must prevent the CO in the flue gases exceeding 1% (10,000 ppm).

To check this, insert a combustion analyser into the chimney, slowly close the fan suction inlet (for example with cardboard) and check that the burner locks out, before the CO in the fumes exceeds 1%.

The incorporated air pressure switch can work in a 'differential' mode if connected with two pipes.

If a strong depression in the combustion chamber during the pre-purging phase does not allow the air pressure switch to switch, this can be obtained by applying a second tube between the air pressure switch and the suction inlet of the fan.

In this way, the pressure switch will work in differential mode.



The use of the air pressure switch with differential operation is only allowed in industrial applications and where standards enable the air pressure switch to control only fan operation, without any reference to CO limit.



Connecting the air pressure switch in differential mode, the burner will no longer be certified according to the EN 676 standard.

5.10.2 Maximum gas pressure switch

Adjust the maximum gas pressure switch (Fig. 36) after making all other burner adjustments with the maximum gas pressure switch set to the end of the scale.

To calibrate the maximum gas pressure switch, open the tap and then connect a pressure gauge to its pressure test point.

The maximum gas pressure switch must be regulated to a value no higher than 30% of the measurement read on the gauge when the burner is working at maximum output.

After making the adjustment, remove the pressure gauge and close the tap.

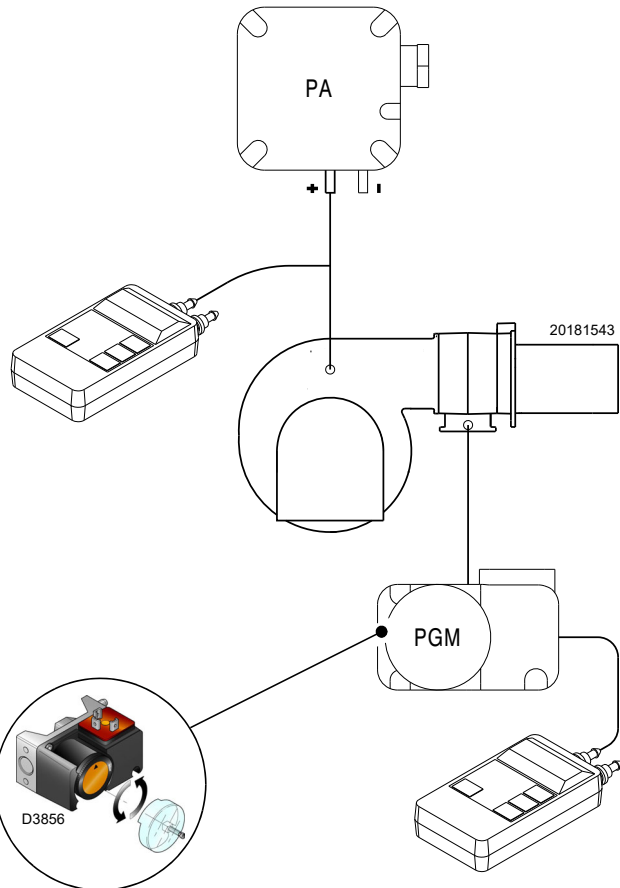

Fig. 36

5.10.3 Minimum gas pressure switch

The purpose of the minimum gas pressure switch is to prevent the burner from operating in an unsuitable way due to too low gas pressure.

Adjust the minimum gas pressure switch (Fig. 37) after having adjusted the burner, the gas valves and the gas train stabiliser. With the burner operating at maximum output:

- install a pressure gauge downstream of the gas train stabiliser (for example at the gas pressure test point on the burner combustion head);
- choke slowly the manual gas cock until the pressure gauge detects a decrease in the pressure read of about 0.1 kPa (1 mbar). In this phase, verify the CO value which must always be less than 100 mg/kWh (93 ppm).
- Increase the adjustment of the gas pressure switch until it intervenes, causing the burner shutdown;
- remove the pressure gauge and close the cock of the gas pressure test point used for the measurement;
- open completely the manual gas cock.

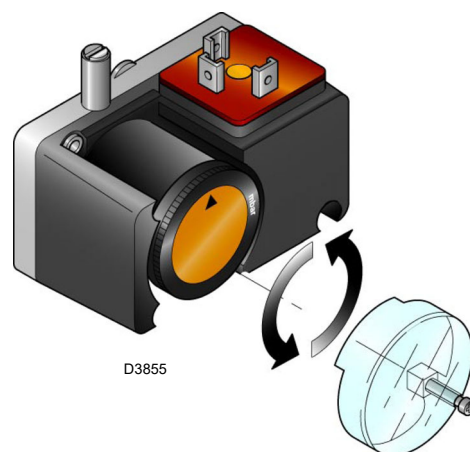

Fig. 37



1 kPa = 10 mbar

5.11 Burner operation

5.11.1 Burner start-up

- 0s:** Control remote control TL closes. Fan motor start-up.
- 6s:** Servomotor start-up: turn to the right by 130°, i.e. until the contact intervenes on cam I (Fig. 34, on page 27). The air damper is positioned to MAX output.
- 48s:** Pre-purging stage with MAX output air delivery. Duration 32 s.
- 80s:** The servomotor turns to the left to reach the angle set on cam III (Fig. 34, on page 27) for the MIN output.
- 112s:** The air damper and the gas butterfly valve reach the MIN output position (with cam III)(Fig. 34, on page 27) at 40°.
- 115s:** Ignition electrode strikes a spark.
- 120s:** The safety valve VS and the adjustment valve VR open (quick opening). The flame ignites with a small output - point A. The output gradually increases, and the VR valve slowly opens, until the MIN output is reached - point B.
- 123s:** The spark goes out.
- 135s:** The start-up cycle ends.

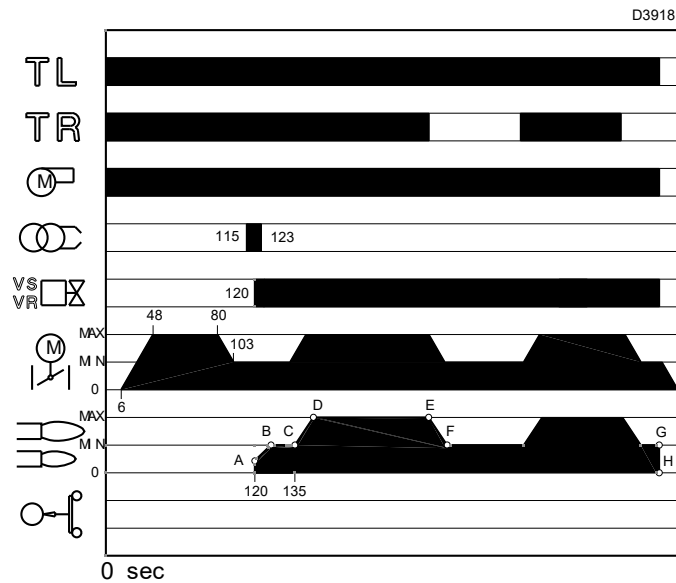

Fig. 38

5.11.2 Steady state operation

Burner without RWF50 output regulator

At the end of the start-up cycle, the servomotor control switches to TR remote control that controls the pressure or temperature in the boiler, point C. (The flame control carries on checking the presence of the flame and the correct position of the air and gas maximum pressure switches).

- If the temperature or pressure is low (so the TR remote control is closed), the burner progressively increases the output up to the MAX value (section C-D).
- If the temperature or pressure then increases until the TR opens, the burner progressively decreases its output to the MIN value (section E-F). And so on.
- The burner locks out when the heat request is less than the heat supplied by the burner at MIN output, (section G-H). The TL remote control opens, the servomotor returns to angle 0° limited by the contact of cam II page 27. The air damper closes completely to reduce heat losses to a minimum.

With each change of output, the servomotor automatically modifies the gas output (butterfly valve) and the air flow rate (fan damper).

Burner with RWF50 output regulator

See the manual supplied with the adjuster.

5.11.3 Ignition failure

If the burner does not ignite, it locks out within 3s after the gas valve opens, and the post-purging phase starts lasting 17s, i.e. 119s from TL closure.

Burner flame goes out during operation

If the flame goes out during operation, the burner will lock out within 1s.

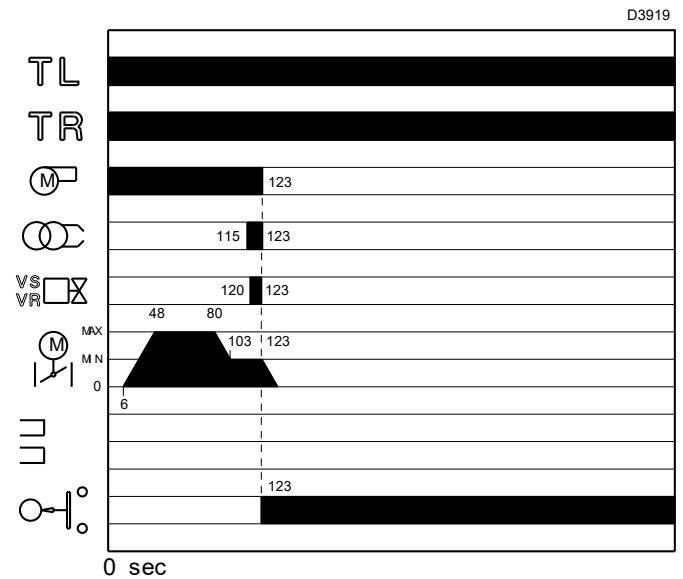

Fig. 39

5.11.4 Final checks (with burner operating)

- Disconnect a wire of the minimum gas pressure switch:
- Open TL remote control:
- Open TS remote control:

the burner must stop

- Disconnect the P shared wire of the maximum gas pressure switch:
- Disconnect the P shared wire of the air pressure switch:
- Disconnect electrically the sensor for the flame detection

the burner must stop in lockout

- Make sure that the mechanical locking systems on the adjustment devices are fully tightened.

6 Maintenance

6.1 Notes on safety for the maintenance

The periodic maintenance is essential for the good operation, safety, yield and duration of the burner.

It allows you to reduce consumption and polluting emissions and to keep the product in a reliable state over time.



The maintenance interventions and the calibration of the burner must only be carried out by qualified, authorised personnel, in accordance with the contents of this manual and in compliance with the standards and regulations of current laws.

Before carrying out any maintenance, cleaning or checking operations:



Disconnect the electrical supply from the burner by means of the system main switch.



Close the fuel shut-off valve.



Wait for the components in contact with heat sources to cool down completely.

6.2 Maintenance programme

6.2.1 Maintenance frequency



The gas combustion system should be checked at least once a year by a representative of the manufacturer or another specialised technician.

6.2.2 Safety test - with no gas supply

To perform commissioning in safety conditions, it is very important to check correct wiring between gas valves and burner.

For this purpose, after checking that connections comply with the burner wiring diagrams, it is necessary to carry out a start-up cycle with gas cock closed (dry test).

- 1 The manual gas valve must be closed using the locking/unlocking device ("Lock-out / tag out" procedure).
- 2 Ensure that burner limit electrical contacts are closed
- 3 Ensure that minimum gas pressure switch contact is closed
- 4 Try to start the burner.

The start-up cycle must occur according to the following steps:

- Fan motor start-up for pre-purging
- Gas valve leak detection control, if applicable.
- Pre-purging completion
- Achievement of the ignition point
- Power supply of the ignition transformer
- Supply of gas valves.

As gas is closed, the burner cannot ignite and its flame control will switch to stop or safety lockout condition.

The actual supply of gas valves can be checked by inserting a tester; some valves are equipped with lights (or closing/opening position indicators) that activate as soon as they are powered.



IF POWER SUPPLY OF GAS VALVES OCCURS IN UNEXPECTED MOMENTS, DO NOT OPEN THE MANUAL VALVE, DISCONNECT POWER SUPPLY, CHECK WIRINGS, CORRECT THE ERRORS AND CARRY OUT THE WHOLE TEST AGAIN.

6.2.3 Checking and cleaning



The operator must use the required equipment during maintenance.

Burner

Check that there are not excess wear or loosen screws. The screws securing the electrical leads in the burner plugs should also be fully tightened.

Clean the outside of the burner.

Clean and grease the adjustable profile of the cams.

Boiler

Clean the boiler as indicated in its accompanying instructions in order to maintain all the original combustion characteristics intact, especially: the flue gas temperature and combustion chamber pressure.

Combustion

Carry out an analysis of the combustion flue gases.

Significant differences with respect to the previous measurements indicate the points where most care should be exercised during maintenance.

Electrical current to flame sensor (Fig. 40)

Clean the glass cover from any dust that may have accumulated. To remove the sensor pull it outwards with force; it is inserted only by pressure.

Min. value for a good work: 70 μ A.

If the value is lower, it could be due to:

- exhausted sensor;
- low voltage (lower than 187 V);
- bad regulation of the burner.

In order to measure the current, use a microammeter of 100 μ A d.c., connected in series to the sensor, as in the scheme, with a capacitor of 100 μ F - 1V d.c. at the same level of the instrument.

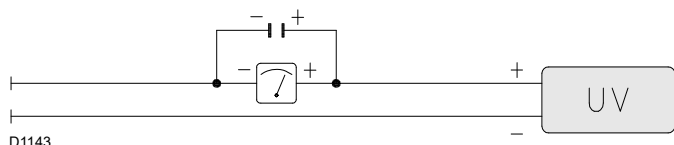

Fig. 40

Flame inspection window

Clean the glass of the flame inspection window.

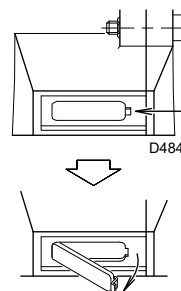

Fig. 41

Servomotor

Release cam 4)(Fig. 36, on page 28) from the servomotor, by pressing and shifting button 3)(Fig. 37, on page 29) to the right. Manually rotate it backwards and forwards to make sure it moves smoothly. Now engage the cam again by shifting the button 2)(Fig. 37, on page 29) to the left.

Combustion head

Open the burner and make sure that all components of the combustion head are in good condition, not deformed by the high temperatures, free of impurities from the surroundings and correctly positioned.

Fan

Check to make sure that no dust has accumulated inside the fan or on its impellers, as this condition will cause a reduction in the air flow rate and provoke polluting combustion.

LIGHT OIL OPERATION

GAS OPERATION

Fuel tank

Approximately every 5 years, suck any water on the bottom of the tank using a separate pump.

Combustion

If the combustion values measured before starting maintenance do not comply with applicable Standards or do not indicate efficient combustion, consult the table below or contact our Technical Support Service to implement the necessary adjustments.

Filters

Check the filtering baskets on line and at nozzle present in the system.

Clean or replace if necessary.

If rust or other impurities are observed inside the pump, use a separate pump to lift any water and other impurities that may have deposited on the bottom of the tank.

Pump pressure

12 bar: this is the factory-calibrated pressure, which is usually correct for most purposes.

Sometimes, this pressure must be adjusted to:

10 bar in order to reduce fuel delivery.

It is possible only if the ambient temperature remains above 0 C;

14 bar in order to increase fuel delivery or to ensure firings even at temperatures of less than 0 °C.

In order to change pump pressure, act on screw 5)(Fig. 21, on page 19).

Flexible hoses

Check to make sure that the hoses are still in good condition.

Nozzles

It is advisable to replace nozzles once a year during periodical maintenance.

Do not clean the nozzle openings.

Gas leaks

Make sure that there are no gas leaks on the pipe between the gas meter and the burner.

Gas filter

Change the gas filter when it is dirty.

Combustion

If the combustion values measured before starting maintenance do not comply with applicable Standards or do not indicate efficient combustion, consult the table below or contact our Technical Support Service to implement the necessary adjustments.

6.2.4 Combustion control (gas)

CO₂

It is advisable to adjust the burner with a CO₂ not greater than about 10% (gas with Ncv 8600 kcal/m³).

In this way it is avoided that a small decalibration (for example a variation in the tension) could cause a combustion with an air defect and with the subsequent formation of CO.

CO

It should not exceed 100 mg/kWh.

6.2.5 Safety components

The safety components should be replaced at the end of their life cycle indicated in the following table.

The specified life cycles do not refer to the warranty terms indicated in the delivery or payment conditions.

Safety component	Life cycle
Flame control	10 years or 250,000 operation cycles
Flame sensor	10 years or 250,000 operation cycles
Gas valves (solenoid)	10 years or 250,000 operation cycles
Pressure switches	10 years or 250,000 operation cycles
Pressure adjuster	15 years
Servomotor (electronic cam)	10 years or 250,000 operation cycles
Oil valve (solenoid)	10 years or 250,000 operation cycles
Oil regulator	10 years or 250,000 operation cycles
Pipes/ oil fittings (metallic)	10 years
Fan impeller	10 years or 500,000 start-ups

Tab. K

6.3 Opening the burner



Disconnect the electrical supply from the burner by means of the main system switch.



Close the fuel shut-off valve.



Wait for the components in contact with heat sources to cool down completely.

- Cut off the voltage
- Loosen the screws 1)(Fig. 42) and remove the cover 2).
- Disconnect the light oil pipes 7).
- Disengage the articulated coupling 8) from the graduated sector 9).
- Remove the screws 10) from the two slide bars 4).
- Fit the two extensions on the slide bars 4).
- Refit the screws 10) on the extensions.
- Remove the screws 3) and move the burner backwards by about 100 mm on the slide bars 4).
- Disconnect the electrode cables, then completely retract the burner.

At this point it is possible to extract the inner part 5) after removing the screw 6).

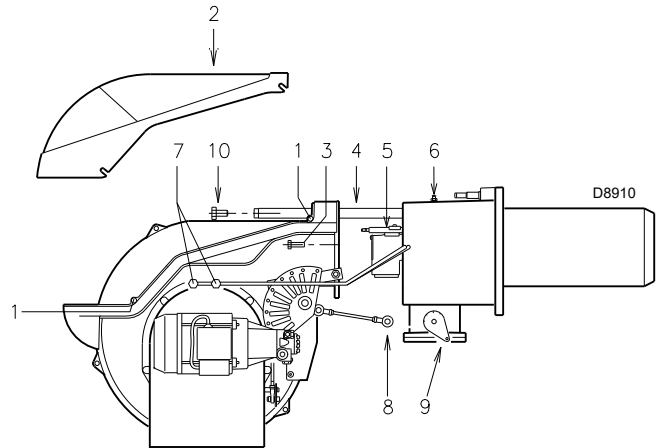

Fig. 42

6.4 Closing the burner

- Push the burner to approximately 100 mm from the pipe coupling.
- Reconnect the cables and slide in the burner until it comes to a stop.
- Replace the screws 3)(Fig. 42) and carefully pull the probe and electrode cables outwards until they are slightly taut.
- Reconnect the articulated coupling 8) to the graduated sector 9).
- Reconnect the light oil pipes 7).
- Disassemble both slide bar extensions 4) and place them in the original position.



After carrying out maintenance, cleaning or checking operations, reassemble the cover and all the safety and protection devices of the burner.

7 Faults - Possible causes - Solutions

The LFL1... flame control is equipped with a lockout indicator (Fig. 43) that turns during the start-up programme, and is visible from the small lockout window.

When the burner does not start or stops, due to a failure, the symbol that appears on the indicator indicates the type of interruption.

The positions of the lockout indicator are shown in Fig. 44.



Lockout indicator

- a-b Start-up sequence
- b(b') Idle stages (without contact confirmation)
- b(b')-a Post-purging programme

Fig. 43

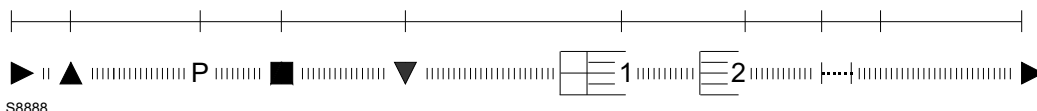

Fig. 44

Fuse replacement

The fuse 2)(Fig. 45) is in the rear part of the flame control. A spare fuse 1) is also available: it can be extracted after breaking the panel tab A) that houses it.

Find a list of faults, causes and possible solutions for a set of failures that may occur and result in irregular burner operation or no functioning at all.

If a burner malfunction is detected, first of all:

- check that the electrical wiring is adequately connected;
- check whether fuel is delivered;
- check that every adjustment parameter is adequately set.

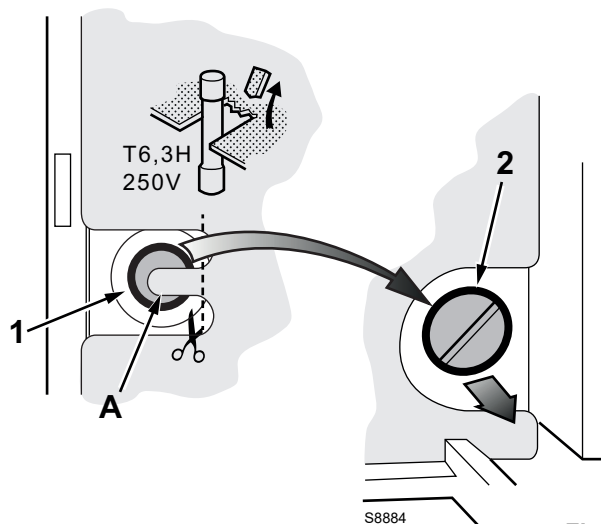

Fig. 45



ATTENTION

In the event the burner stops, in order to prevent any damage to the installation, do not unblock the burner more than twice in a row. If the burner locks out for a third time, contact the customer service.



DANGER

In the event there are further lockouts or faults with the burner, the maintenance interventions must only be carried out by qualified, authorised personnel, in accordance with the contents of this manual and in compliance with the standards and regulations of current laws.

7.1 Light oil operation

Symbol	Problem	Probable cause	Suggested remedy	
◀	The burner does not start	Limiters or safety control device open	Adjust or replace	
		Flame control lockout	Release	
		Fan motor lockout	Release the thermal relay	
		No electrical power supply	Close all switches - check connections	
		No light oil	Check the light oil supply circuit	
		Flame control fuse interrupted	Replace	
		Pump is jammed	Replace	
		Faulty motor remote control switch	Replace	
		Defective flame control	Replace	
		Faulty electrical motor	Replace	
		Defective safety solenoid valve	Replace	
		The burner does not come on and the lockout appears	Flame simulation	Replace the flame control
			Flame sensor short circuit	Replace flame sensor
			Two-phase electrical supply, thermal relay steps in	Reset the thermal relay at return of the three phases
▲	The burner starts but stops at maximum air damper setting	The servomotor contact does not intervene	Adjust cam or replace servomotor	
P	The burner starts and then goes into lockout	Air pressure switch poorly adjusted	Adjust it	
		Pressure switch pressure point pipe blocked	Clean	
■	The burner starts and then goes into lockout	Failure to the flame detection circuit	Replace flame control	
▼	The burner remains in pre-purging phase	The servomotor contact III does not intervene	Adjust cam or replace servomotor	
1	Once the pre-purging and the safety time has elapsed the burner goes into lockout without the flame appearing	No fuel in the tank, or water on the bottom	Refill with fuel, or remove the water	
		Bad head and damper adjustments	Adjust	
		High voltage cable defective or grounded	Replace	
		High voltage cable deformed by high temperature	Replace and protect	
		Bad electrical wiring on valves or transformer	Check	
		Pump unprimed	Prime it	
		Pump suction line connected to return line	Correct connection	
		Soiled filters (nozzle line)	Clean	
		Valves up-line from pump closed	Open them	
		Opposite motor rotation	Change electrical wiring to the motor	
		Light oil solenoid valves do not open	Check connections and solenoids	
		Pilot burner does not work	Check	
		Defective flame control	Replace	
		Ignition electrode incorrectly adjusted	Adjust it	
		Electrode grounded due to broken insulation	Replace	
		Motor/pump coupling broken	Replace	
		Faulty ignition transformer	Replace	
		The flame ignites regularly but the burner goes into lock out at the end of the safety time	Faulty flame sensor or defective flame control	Replace flame sensor or flame control
			Dirty flame sensor	Clean
		Smoke in flame (dark Bacharach)	Little air	Adjust the fan head and damper
Incorrect pump pressure			Adjust	
Nozzle filter clogged			Clean or replace	
Boiler room air vents insufficient			Increase	
Dirty or worn nozzle			Replace	
Flame disk soiled, loose or deformed			Clean it, tighten it or replace it	
	Smoke in flame (yellow Bacharach)	Too much air	Adjust head and air dampers	

Symbol	Problem	Probable cause	Suggested remedy
	Ignition with pulses or flame failure, delayed ignition	Poorly adjusted head	Adjust
		Incorrectly adjusted fan air damper: too much air	Adjust
		Nozzle not fit for burner or boiler	See nozzle table
		Defective nozzle	Replace
		Unsuitable pump pressure	Adjust
		Ignition electrode not adjusted correctly or soiled	Adjust it
		Output during ignition phase is too high	Reduce
	The burner does not pass to the 2nd stage	Remote control device TR fails to close	Adjust or replace
		Defective flame control	Replace
	Uneven fuel supply	Understand whether the cause lies in the pump or the fuel supply system	Supply fuel to the burner from a tank positioned near the burner itself
	Pump rusty on the inside	Water in the tank	Remove the water with a pump
	Noisy pump, unstable pressure	Air has entered the suction line	Block the couplings
		Depression value too high (higher than 35 cm Hg):	
		Excessive difference of level between burner and tank	Power the burner from a loop circuit
		Piping diameter too small	Increase
		Dirty suction line filters	Clean
		Suction line valves closed	Open them
		The paraffin solidifies due to the low temperature	Put additive in the light oil
	Pump unprimes after prolonged pause	Return pipe not immersed in fuel	Bring it to the same height as the suction line
		Air in the suction line	Block the couplings
	Pump leaks light oil	Loss of sealing organ	Replace the pump
	Dirty combustion head	Dirty nozzle or nozzle filter	Replace
		Unsuitable nozzle delivery or angle	See recommended nozzles
		Loose nozzle	Block it
		Environmental impurities on flame stability disc	Clean
		Incorrect head adjustment, or little air	Adjust it, opening the damper
		Blast tube length not suitable for the boiler	Contact the boiler manufacturer
I	Burner goes into lockout during operation	Flame sensor faulty or dirty	Replace it or clean it
		Air pressure switch faulty	Replace

Tab. L

7.2 Gas operation

Symbol	Problem	Probable cause	Suggested remedy
◀	The burner does not start	No electrical power supply	Close all switches and check connections
		A limit or safety thermostat/pressure switch open	Adjust or replace
		Flame control lockout	Release the flame control
		Flame control fuse interrupted	Replace it (2)
		Incorrect electrical wiring	Check
		Defective flame control	Replace
		No gas supply	Open the manual valves between meter and train
		Mains gas pressure insufficient	Contact your GAS COMPANY
		Minimum gas pressure switch fails to close	Adjust or replace
		Air pressure switch in operating position	Adjust or replace
		The servomotor contact does not intervene (closure cam 0°)	Adjust the closure cam 0° or replace the servomotor
	The burner does not come on and the lockout appears	Flame simulation	Replace the flame control
		Faulty motor remote control switch	Replace
		Defective electrical motor	Replace
▲	The burner starts but stops at maximum air damper setting	Motor lockout	Release the thermal relay
		The servomotor contact does not intervene (maximum cam opening)	Cam adjustment (maximum opening) or replace the servomotor
P	The burner starts and then goes into lockout	Air pressure switch does not switch owing to lack of air pressure:	
		Air pressure switch poorly adjusted	Adjust or replace
		Pressure switch pressure point pipe clogged	Clean
		Poorly adjusted head	Adjust
		Dirty fan	Clean
■	The burner turns on and then remains in lockout mode	High depression in the furnace	Contact our Technical Department
		Failure to the flame detection circuit	Replace the flame control
▼	The burner remains in pre-purging phase	The servomotor contact does not intervene (minimum cam)	Cam adjustment (minimum) or replace the servomotor

Symbol	Problem	Probable cause	Suggested remedy
1	Once the pre-purging and the safety time has elapsed the burner goes into lockout without the flame appearing	The GAS solenoid valve lets too little gas through	Increase
		The GAS solenoid valve does not open	Replace the coil or the rectifier panel
		Gas pressure too low	Increase pressure at governor
		Ignition electrode incorrectly adjusted	Adjust it
		Electrode grounded due to broken insulation	Replace
		High voltage cable defective or grounded	Replace
		High voltage cable deformed by high temperature	Replace and protect
		Faulty ignition transformer	Replace
		Incorrect valve or ignition transformer connections	Redo them
		Defective flame control	Replace
		A closed valve upstream the gas train	Open
		Air in pipework	Bleed air
		Lockout with flame appearing	The GAS solenoid valve lets too little gas through
	Dirty flame sensor		Check, replace flame sensor
Faulty connection	Check, replace flame sensor		
Insufficient detection current (min.70 µA)	Measure current, replace flame sensor		
Flame sensor exhausted, faulty	Replace		
Maximum gas pressure switch intervention	Adjust or replace		
Defective flame control	Replace		
	The burner continues to repeat the start-up cycle without lockout	The gas pressure in the gas mains lies very close to the value to which the gas pressure switch has been set. The sudden drop in pressure after valve opening causes temporary opening of the pressure switch itself, the valve immediately closes and the burner stops. Pressure increases again, the pressure switch closes again and the ignition cycle is repeated. And so on.	Reduce the intervention pressure of the minimum gas pressure switch. Replace the gas filter cartridge
	Lockout without symbol indication	Flame simulation	Replace the flame control
	Burner goes into lockout during operation	Faulty flame sensor	Replace worn parts
		Air pressure switch faulty	Replace
◀	Lockout when the burner stops	Permanent flame in the combustion head or flame simulation	Eliminate permanency of flame or replace the flame control
	Ignition with pulsations	Poorly adjusted head	Adjust
		Ignition electrode incorrectly adjusted	Adjust it
		Incorrectly adjusted fan air damper: too much air	Adjust
		Output during ignition phase is too high	Reduce

Tab. M

A Appendix - Accessories

Output power regulator kit for modulating operation

With the modulating operation, the burner continually adapts the power to the request for heat, ensuring great stability for the parameter controlled: temperature or pressure.

Two components should be ordered:

- the output regulator to install on the burner;
- the probe to install on the heat generator.

Parameter to control		Probe		Output power regulator	
	Range	Type	Code	Type	Code
Temperature	- 100...+ 500°C	PT 100	3010110	RWF50 RWF55	20099869 20099905
Pressure	0...2,5 bar	Probe with output 4...20 mA	3010213		
	0...16 bar		3010214		
	0...25 bar			3090873	

Extended head kit

Burner	Code
RLS 250/M MZ	3010440

Potentiometer kit

Burner	Code
RLS 250/M MZ	3010416

E5202 kit

Burner	Code
RLS 250/M MZ	3010415

Soundproofing box kit

Burner	Code
RLS 250/M MZ	3010404

Continuous ventilation kit

Burner	Code
RLS 250/M MZ	3010094

Spacer kit

Burner	Code
RLS 250/M MZ	3000722

Ground fault interrupter kit

Burner	Codice
RLS 250/M MZ	20098337

Gas trains in compliance with EN 676

Please refer to manual.



WARNING

The installer is responsible for the addition of any safety device not foreseen in this manual.

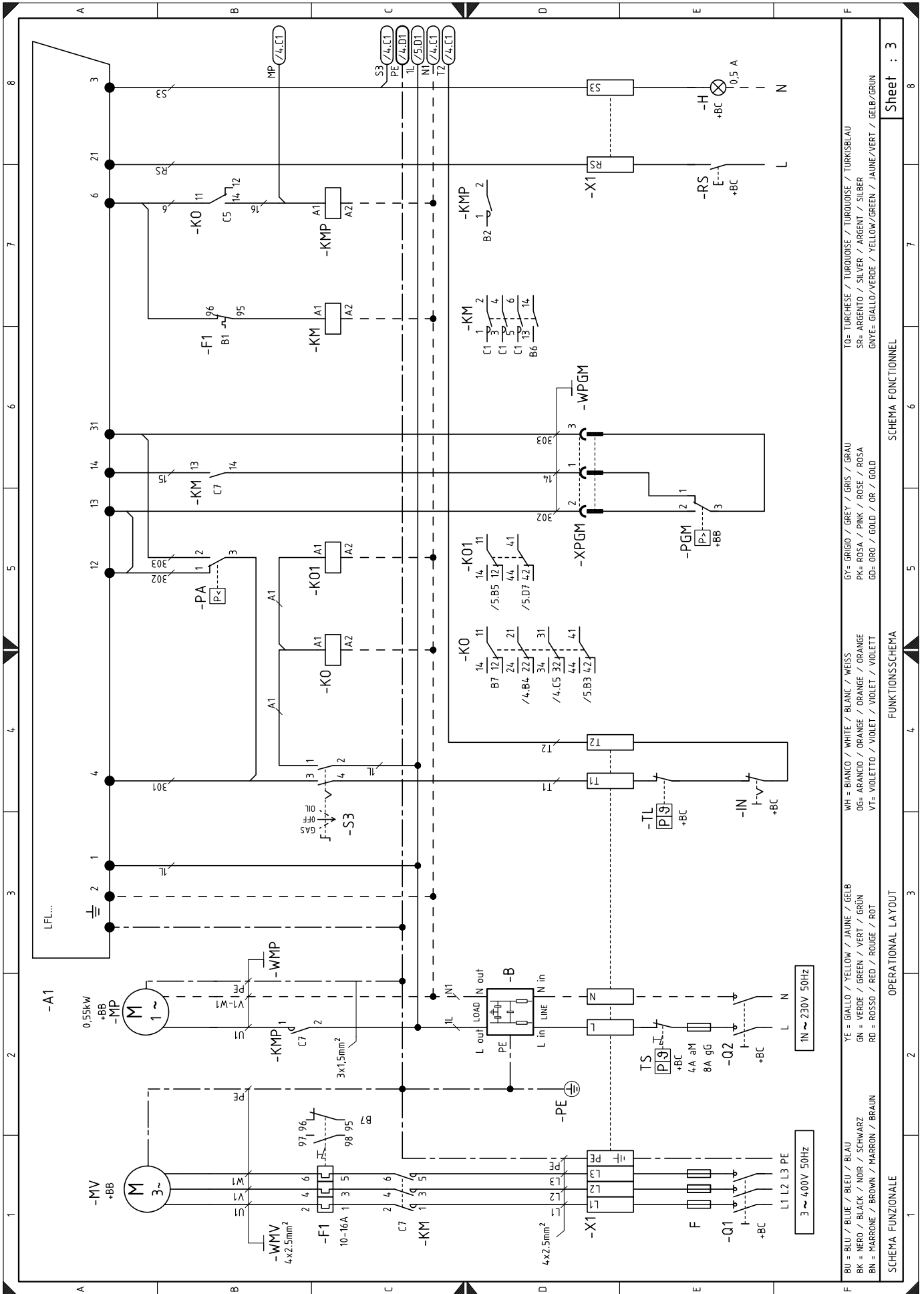

Sheet : 3

SCHEMA FONCTIONNEL

FUNKTIONSSCHEMA

OPERATIONAL LAYOUT

SCHEMA FUNZIONALE

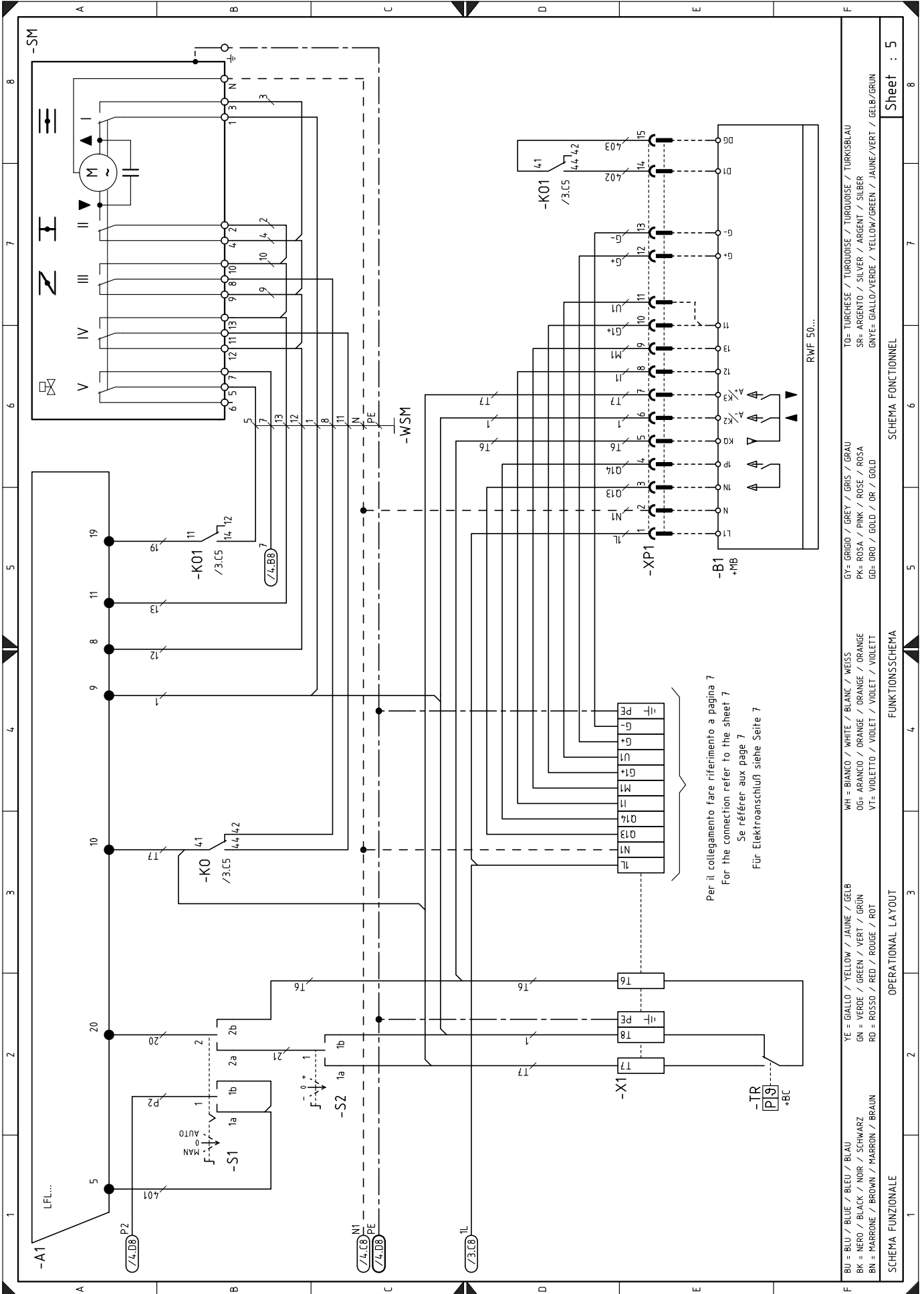

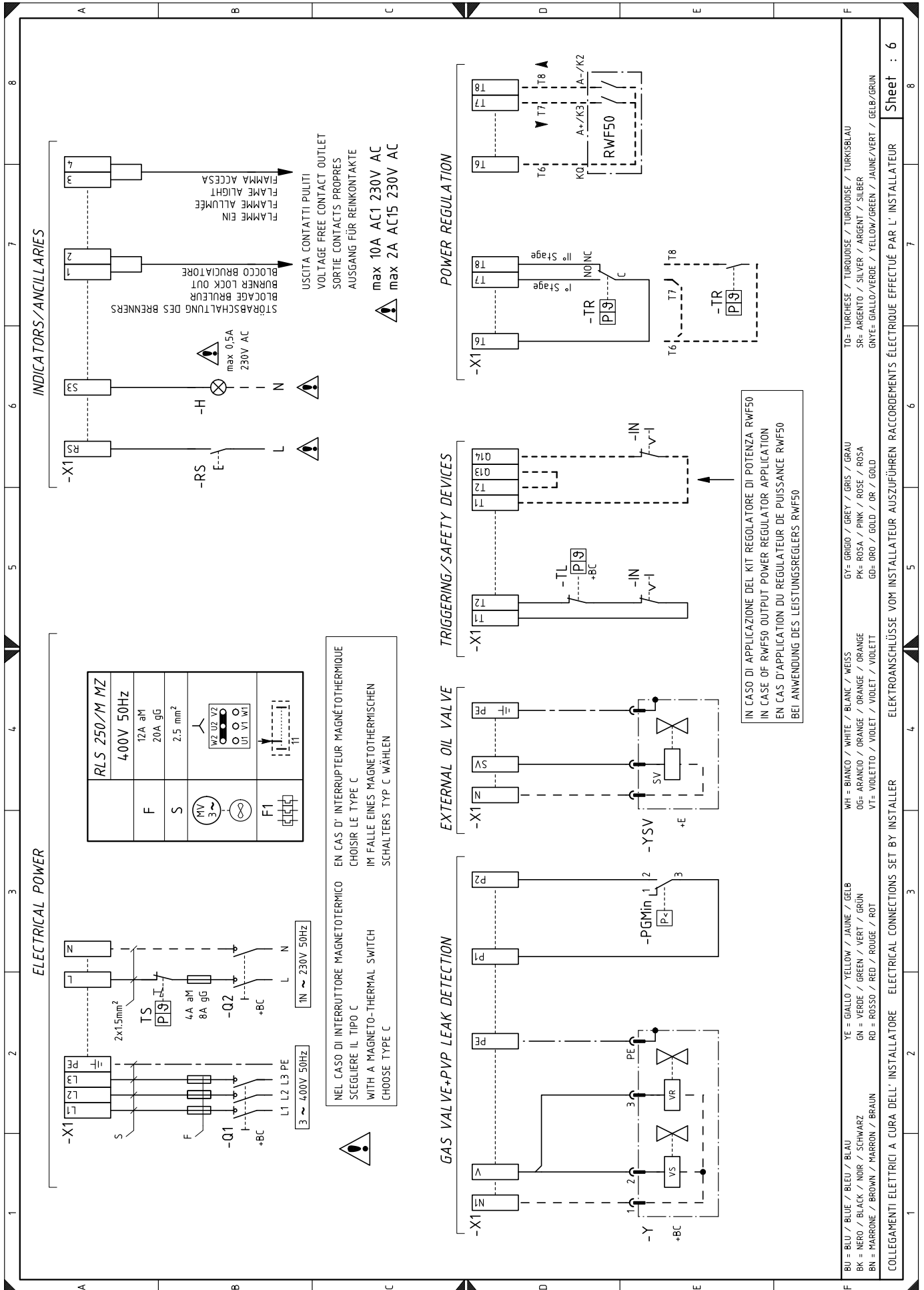

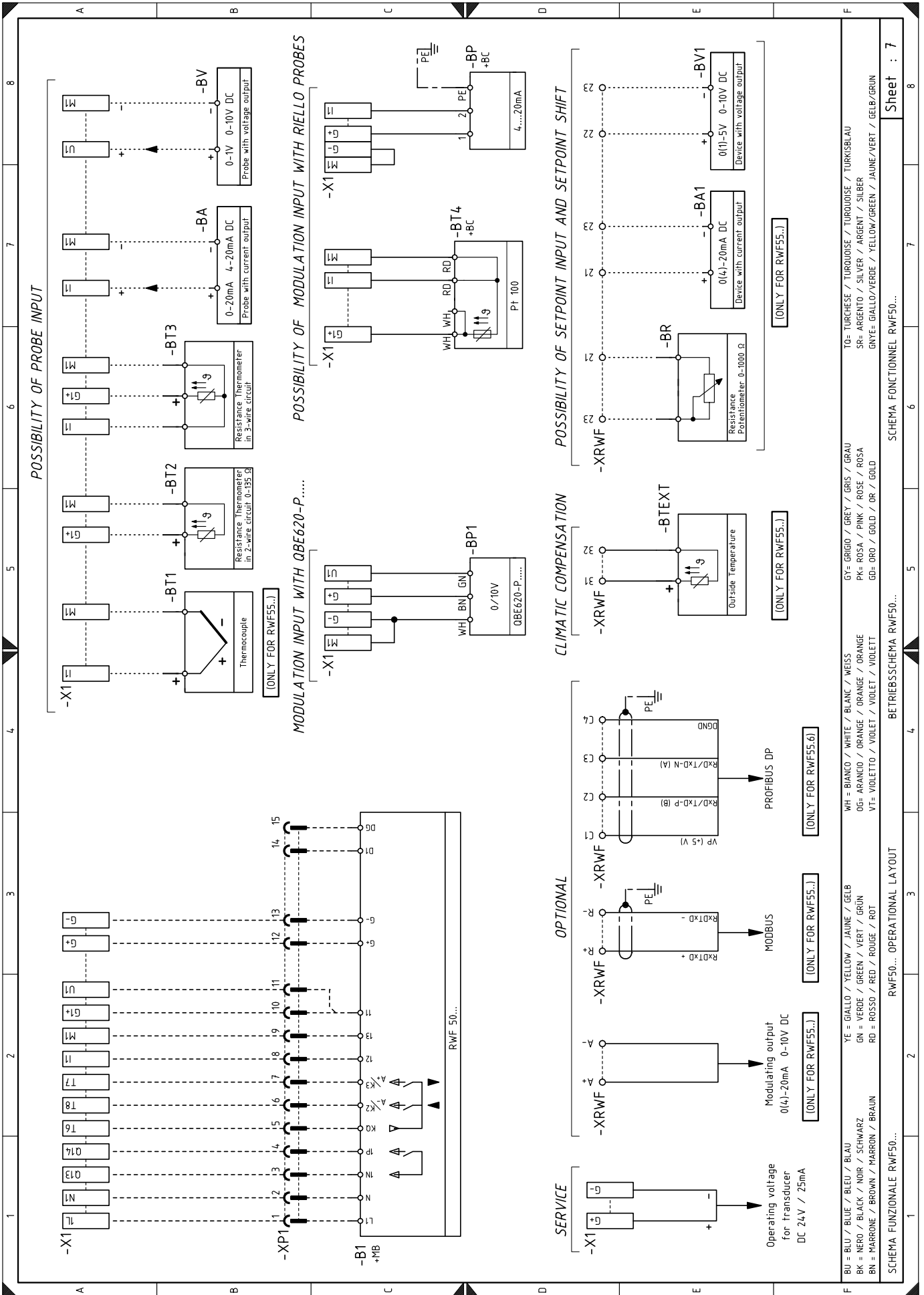

BU = BLU / BLUE / BLEU / BLAU
 BK = NERO / BLACK / NOIR / SCHWARZ
 BN = MARRONE / BROWN / MARRON / BRAUN
 YE = GIALLO / YELLOW / JAUNE / GELB
 GN = VERDE / GREEN / VERT / GRÜN
 RD = ROSSO / RED / ROUGE / ROT
 WH = BIANCO / WHITE / BLANC / WEISS
 OG= ARANCIO / ORANGE / ORANGE / ORANGE
 VT= VIOLETTO / VIOLET / VIOLET / VIOLET
 GY= GRIGIO / GREY / GRIS / GRAU
 PK= ROSA / PINK / ROSE / ROSA
 GO= ORO / GOLD / OR / GOLD
 TO= TURCHESE / TURQUOISE / TURQUOISE / TURKISBLAU
 SR= ARGENTO / SILVER / ARGENT / SILBER
 GNYE= GIALLO/VERDE / YELLOW/GREEN / JAUNE/VERT / GELB/GRÜN

Wiring layout key

A1	Flame control	V2	2nd stage adjustment valve
B	Protection against radio interference	Y	Gas adjustment valve + gas safety valve
B1	Output power regulator RWF	YVPS	Gas leak detection control device
BA	DC input 4...20 mA	X1	Main supply terminal strip
BA1	DC input 4...20 mA for modifying the remote setpoint	XPGM	Maximum gas pressure switch connection plug
+BB	Burners components	XP1	Socket for kit
+BC	Boiler components	XPE	Flame control earth
BP	Pressure probe	XRWF	RWF terminal strip
BP1	Pressure probe		
BR	Remote setpoint voltage divider		
BT1	Thermocouple probe		
BT2	Probe Pt100 with 2 wires		
BT3	Probe Pt100 with 3 wires		
BT4	Probe Pt100 with 3 wires		
BTEXT	External probe for the climatic compensation of the setpoint		
BV	DC voltage input 0...10 V		
BV1	DC voltage input 0...10 V for modifying the remote setpoint		
+E	External burner components		
F	Protection fuses for three phase line		
F1	Fan motor thermal cut-out		
H	Remote lock-out signal		
IN	Burner manual stop switch		
K1	Flame ON voltage free contact relay		
K2	Burner lock-out voltage free contact relay		
KM	Motor contactor		
KMP	Relay		
KO	Relay		
KO1	Relay		
MP	Pump motor		
MV	Fan motor		
PA	Air pressure switch		
PE	Burner ground		
PGMin	Minimum gas pressure switch		
PGM	Maximum gas pressure switch		
Q1	Three-phase disconnect switch		
Q2	Single-phase disconnect switch		
RS	Remote lock-out reset button		
S1	Switch for following operations: off-automatic-manual		
S2	Button for: power increase/reduction		
S3	Oil/gas selector		
SM	Servomotor		
SV	External oil valve		
TA	Ignition transformer		
TL	Limit pressure switch/thermostat		
TR	Control pressure switch/thermostat		
TS	Safety pressure switch/thermostat		
UV	Flame sensor		
VS	Safety valve		
V1	1st stage adjustment valve		

RIELLO

RIELLO S.p.A.
I-37045 Legnago (VR)
Tel.: +39.0442.630111
[http:// www.riello.it](http://www.riello.it)
[http:// www.riello.com](http://www.riello.com)