

**GB** **Forced draught gas burners**

Two stage progressive or modulating operation

**CE****UK  
CA****EAC**

CODE	MODEL	TYPE
20205990	GAS 8 P/M	538 T1
20213790	GAS 8 P/M	538 T1
20213791	GAS 9 P/M	540 T1
20205585	GAS 9 P/M	540 T1
20213792	GAS 9 P/M	540 T1
20206138	GAS 10 P/M	541 T1
20205654	GAS 10 P/M	541 T1



**Translation of the original instructions**

<b>1</b>	<b>Information and general warnings.....</b>	<b>3</b>
1.1	Information about the instruction manual .....	3
1.1.1	Introduction.....	3
1.1.2	General dangers.....	3
1.1.3	Other symbols .....	3
1.1.4	Delivery of the system and the instruction manual .....	4
1.2	Guarantee and responsibility.....	4
<b>2</b>	<b>Safety and prevention.....</b>	<b>5</b>
2.1	Introduction.....	5
2.2	Personnel training .....	5
<b>3</b>	<b>Technical description of the burner .....</b>	<b>6</b>
3.1	Burner designation .....	6
3.2	Models available.....	6
3.3	Technical data .....	7
3.4	Electrical data.....	7
3.5	Maximum dimensions.....	8
3.6	Burner equipment.....	8
3.7	Firing rates .....	9
3.8	Test boiler.....	10
3.8.1	Commercial boilers.....	10
3.9	Burner description .....	11
3.10	Electrical panel description.....	12
3.11	Flame control (LFL...).....	13
3.12	Servomotor SQM40 .....	14
<b>4</b>	<b>Installation .....</b>	<b>15</b>
4.1	Notes on safety for the installation .....	15
4.2	Handling .....	15
4.3	Preliminary checks .....	15
4.4	Operating position .....	16
4.5	Preparing the boiler .....	16
4.5.1	Boring the boiler plate .....	16
4.5.2	Blast tube length.....	16
4.5.3	Securing the burner to the boiler .....	17
4.6	Positioning the probe - electrode.....	18
4.7	Combustion head adjustment.....	19
4.7.1	Fixed gas delivery adjustment.....	19
4.8	Gas supply .....	20
4.8.1	Gas feeding line (Example) - Please refer to the gas train documentation .....	20
4.8.2	Gas train .....	21
4.8.3	Gas train installation .....	21
4.8.4	Gas pressure .....	21
4.9	Electrical connections.....	23
4.10	Calibration of the thermal relay (only model GAS 8-9 P/M) .....	24
4.11	Motor rotation .....	24
<b>5</b>	<b>Start-up, calibration and operation of the burner .....</b>	<b>25</b>
5.1	Notes on safety for the first start-up .....	25
5.2	Adjustments prior to ignition .....	25
5.3	Burner start-up .....	25
5.4	Burner ignition .....	25
5.5	Burner adjustment.....	26
5.5.1	Combustion head .....	26
5.6	Servomotor adjustment .....	28

5.6.1	Output upon ignition .....	28
5.6.2	Preliminary calibrations, if necessary .....	29
5.6.3	Maximum output .....	30
5.6.4	Minimum output .....	30
5.6.5	Intermediate outputs .....	31
5.7	Pressure switch adjustment .....	32
5.7.1	Air pressure switch .....	32
5.7.2	Maximum gas pressure switch .....	32
5.7.3	Minimum gas pressure switch .....	32
5.7.4	Flame presence check .....	33
5.8	Burner operation .....	34
5.8.1	Burner start-up .....	34
5.8.2	Steady state operation .....	34
5.8.3	Ignition failure .....	34
<b>6</b>	<b>Maintenance .....</b>	<b>35</b>
6.1	Notes on safety for the maintenance .....	35
6.2	Maintenance programme .....	35
6.2.1	Maintenance frequency .....	35
6.2.2	Safety test - with no gas supply .....	35
6.2.3	Checking and cleaning .....	35
6.2.4	Combustion control (gas) .....	36
6.2.5	Safety components .....	36
6.3	Opening the burner .....	37
6.4	Closing the burner .....	37
<b>7</b>	<b>Faults - Possible causes - Solutions .....</b>	<b>38</b>
7.1	Gas operation .....	39
<b>A</b>	<b>Appendix - Accessories .....</b>	<b>41</b>
<b>B</b>	<b>Appendix - Electrical panel layout .....</b>	<b>43</b>

**1 Information and general warnings**

**1.1 Information about the instruction manual**

**1.1.1 Introduction**

The instruction manual supplied with the burner:

- is an integral and essential part of the product and must not be separated from it; it must therefore be kept carefully for any necessary consultation and must accompany the burner even if it is transferred to another owner or user, or to another system. If the manual is lost or damaged, another copy must be requested from the Technical Assistance Centre of the area;
- is designed for use by qualified personnel;
- offers important indications and instructions relating to the installation safety, start-up, use and maintenance of the burner.

**Symbols used in the manual**

In some parts of the manual you will see triangular DANGER signs. Pay great attention to these, as they indicate a situation of potential danger.

**1.1.2 General dangers**

The **dangers** can be of **3 levels**, as indicated below.



Maximum danger level!  
This symbol indicates operations which, if not carried out correctly, cause serious injury, death or long-term health risks.



This symbol indicates operations which, if not carried out correctly, may cause serious injury, death or long-term health risks.



This symbol indicates operations which, if not carried out correctly, may cause damage to the machine and/or injury to people.

**1.1.3 Other symbols**



**DANGER: LIVE COMPONENTS**  
This symbol indicates operations which, if not carried out correctly, lead to electric shocks with lethal consequences.



**DANGER: FLAMMABLE MATERIAL**  
This symbol indicates the presence of flammable materials.



**DANGER: BURNING**  
This symbol indicates the risks of burns due to high temperatures.



**DANGER: CRUSHING OF LIMBS**  
This symbol indicates the presence of moving parts: danger of crushing of limbs.



**WARNING: MOVING PARTS**

This symbol indicates that you must keep limbs away from moving mechanical parts; danger of crushing.



**DANGER: EXPLOSION**

This symbol signals places where an explosive atmosphere may be present. An explosive atmosphere is defined as a mixture - under atmospheric conditions - of air and flammable substances in the form of gases, vapours, mist or dust in which, after ignition has occurred, combustion spreads to the entire unburned mixture.



**PERSONAL PROTECTION EQUIPMENT**

These symbols indicate the equipment that must be worn and kept by the operator for protection against threats against safety and/or health while at work.



**OBLIGATION TO ASSEMBLE THE COVER AND ALL THE SAFETY AND PROTECTION DEVICES**

This symbol signals the obligation to reassemble the cover and all the safety and protection devices of the burner after any maintenance, cleaning or checking operations.



**ENVIRONMENTAL PROTECTION**

This symbol gives indications for the use of the machine with respect for the environment.



**IMPORTANT INFORMATION**

This symbol indicates important information that you must bear in mind.

- This symbol indicates a list.

**Abbreviations used**

Ch.	Chapter
Fig.	Figure
Page	Page
Sec.	Section
Table	Table

### 1.1.4 Delivery of the system and the instruction manual

When the system is delivered, it is important that:

- the instruction manual is delivered to the user by the system manufacturer, with the recommendation to keep it in the room where the heat generator is to be installed.
- The instruction manual shows:
  - the serial number of the burner;

.....
-------

- the address and telephone number of the nearest Assistance Centre;

.....
.....
.....

- The system supplier must carefully inform the user about:
  - the use of the system;
  - any further tests that may be required before activating the system;
  - maintenance, and the need to have the system checked at least once a year by a representative of the manufacturer or another specialised technician.To ensure a periodic check, the manufacturer recommends the drawing up of a Maintenance Contract.

## 1.2 Guarantee and responsibility

The manufacturer guarantees its new products from the date of installation, in accordance with the regulations in force and/or the sale contract. At the moment of the first start-up, check that the burner is integral and complete.



**WARNING**

Failure to observe the information given in this manual, operating negligence, incorrect installation and carrying out of non authorised modifications will result in the annulment by the manufacturer of the guarantee that it supplies with the burner.

In particular, the rights to the guarantee and the responsibility will no longer be valid, in the event of damage to things or injury to people, if such damage/injury was due to any of the following causes:

- incorrect installation, start-up, use and maintenance of the burner;
- improper, incorrect or unreasonable use of the burner;
- intervention of unqualified personnel;
- carrying out of unauthorised modifications on the equipment;
- use of the burner with safety devices that are faulty, incorrectly applied and/or not working;
- installation of untested supplementary components on the burner;
- powering of the burner with unsuitable fuels;
- faults in the fuel supply system;
- continuation of use of the burner when a fault has occurred;
- repairs and/or overhauls incorrectly carried out;
- modification of the combustion chamber with inserts that prevent the regular development of the structurally established flame;
- insufficient and inappropriate surveillance and care of those burner components most likely to be subject to wear and tear;
- use of non-original components, including spare parts, kits, accessories and optional;
- force majeure.

**The manufacturer furthermore declines any and every responsibility for the failure to observe the contents of this manual.**

**2 Safety and prevention**

**2.1 Introduction**

The burners have been designed and built in compliance with current regulations and directives, applying the known safety technical rules and envisaging all the potential danger situations. It is necessary, however, to bear in mind that the imprudent and clumsy use of the equipment may lead to situations of death risk for the user or third parties, as well as the damaging of the burner or other items. Inattention, thoughtlessness and excessive confidence often cause accidents; the same applies to tiredness and sleepiness.

It is a good idea to remember the following:

- The burner must only be used as expressly described. Any other use should be considered improper and therefore dangerous.

Specifically:

it can be applied to boilers operating with water, steam, diathermic oil, and to other uses expressly named by the manufacturer; the type and pressure of the fuel, the voltage and frequency of the electrical power supply, the minimum and maximum deliveries for which the burner has been regulated, the pressurisation of the combustion chamber, the dimensions of the combustion chamber and the ambient temperature must all be within the values indicated in the instruction manual.

- Modification of the burner to alter its performance and destinations is not allowed.
- The burner must be used in exemplary technical safety conditions. Any disturbances that could compromise safety must be quickly eliminated.
- Opening or tampering with the burner components is not allowed, apart from the parts requiring maintenance.
- Only those parts envisaged by the manufacturer can be replaced.



The manufacturer guarantees safety and proper functioning only if all burner components are intact and positioned correctly.

**2.2 Personnel training**

The user is the person, body or company that has acquired the machine and intends to use it for the specific purpose. He is responsible for the machine and for the training of the people working around it.

The user:

- undertakes to entrust the machine exclusively to suitably trained and qualified personnel;
- undertakes to inform his personnel in a suitable way about the application and observance of the safety instructions. With that aim, the user undertakes to ensure that everyone knows the use and safety instructions for his own duties;
- Personnel must observe all the danger and caution indications shown on the machine.
- Personnel must not carry out, on their own initiative, operations or interventions that are not within their province.
- Personnel must inform their superiors of every problem or dangerous situation that may arise.
- The assembly of parts of other makes, or any modifications, can alter the characteristics of the machine and hence compromise operating safety. The manufacturer therefore declines any and every responsibility for any damage that may be caused by the use of non-original parts.

In addition:



- must take all the measures necessary to prevent unauthorised people gaining access to the machine;
- the user must inform the manufacturer if faults or malfunctioning of the accident prevention systems are noticed, along with any presumed danger situation;
- personnel must always use the personal protective equipment envisaged by legislation and follow the indications given in this manual.

**3 Technical description of the burner**

**3.1 Burner designation**

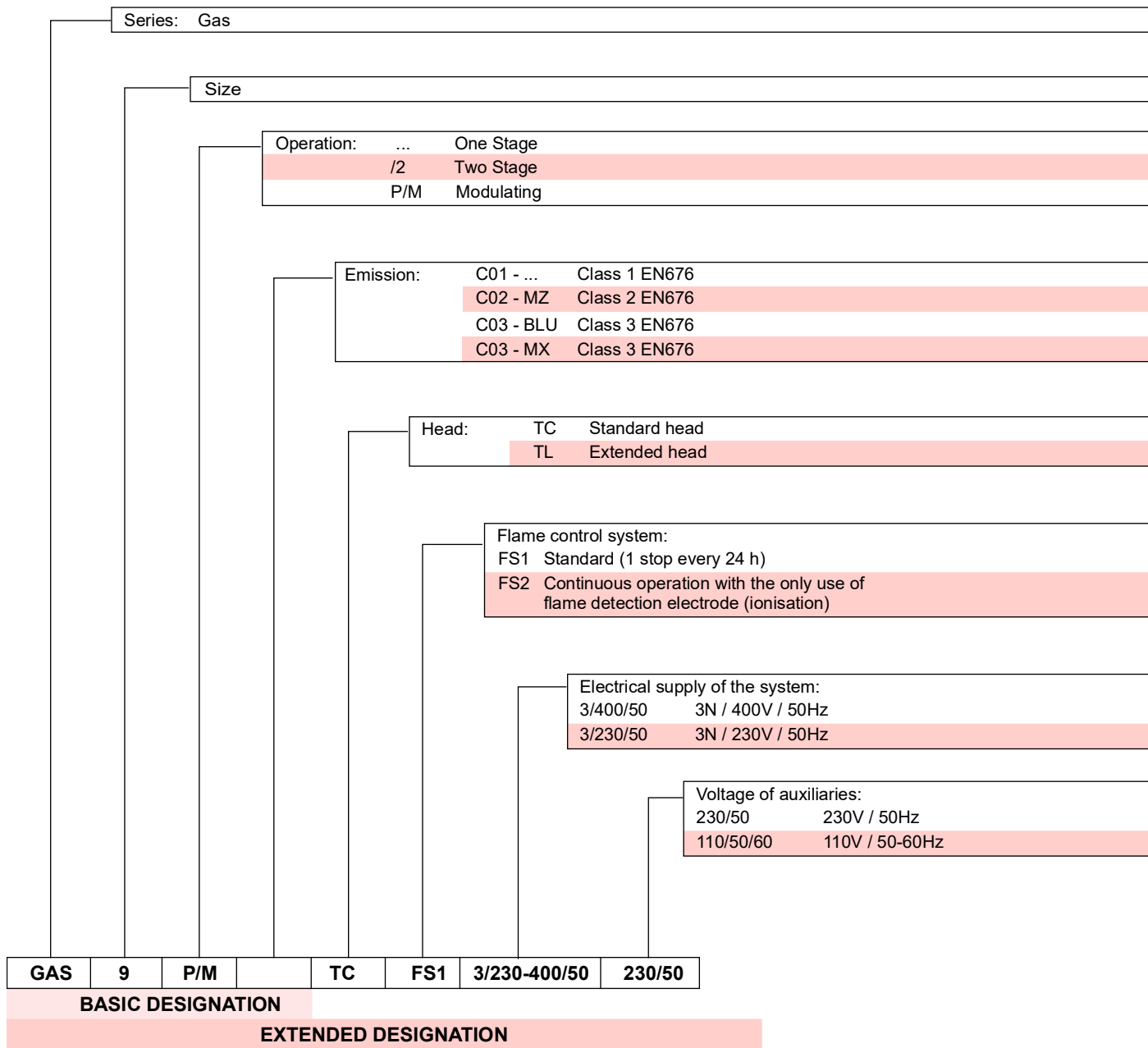

**3.2 Models available**

Designation	Blast tube length (mm)	Voltage	Start-up	Code
GAS 8 P/M	391	3/230-400/50	Direct	20205990
GAS 8 P/M	501	3/230-400/50	Direct	20213790
GAS 9 P/M	444	3/400/50	Direct	20213791
GAS 9 P/M	574	3/400/50	Direct	20205585
GAS 9 P/M	444	3/400/50	Star-triangle	20213792
GAS 10 P/M	476	3/400/50	Star-triangle	20206138
GAS 10 P/M	606	3/400/50	Star-triangle	20205654

**3.3 Technical data**

MODEL			GAS 8 P/M	GAS 9 P/M	GAS 10 P/M
Type			538 T1	540 T1	541 T1
Output <sup>(1)</sup>	2nd stage	kW Mcal/h	1163 - 2210 1000 - 1900	1744 - 3488 1500 - 3000	2441 - 4885 2100 - 4200
	1st stage	kW Mcal/h	640 - 1163 550 - 1000	870 - 1744 750 - 1500	1140 - 2441 980 - 2100
Fuel			NATURAL GAS: G20- G25		
OPERATION			FS1: Intermittent (min. 1 stop in 24 hours)		
Standard applications			Boilers: water, steam, diathermic oil		
Ambient temperature		°C	0 - 40		
NOISE LEVEL <sup>(2)</sup>	Sound pressure	dB(A)	86	89	90
	Sound power		96	99	100
Combustion air temperature		°C max	60		
CE			CE-0476DP3335		

**Tab. A**

- (1) Reference conditions: Ambient temperature 20°C - Gas temperature 15°C - Barometric pressure 1013 mbar - Altitude 0 m a.s.l.  
 (2) Sound pressure measured in manufacturer's combustion laboratory, with burner operating on test boiler and at maximum output. The sound Power is measured using the "Free Field" method, required by the EN 15036 standard, and according to an "Accuracy: Category 3" measurement, as described in EN ISO 3746.

**3.4 Electrical data**

MODEL			GAS 8 P/M	GAS 9 P/M	GAS 10 P/M
Type			538 T1	540 T1	541 T1
Electrical power supply			3 ~ 230 - 400V +/- 10% 50 Hz		
Absorbed electric power		kW max	5	10.6	17
Protection level			IP 40		

**Tab. B**

**3.5 Maximum dimensions**

The dimensions of the burner are given in Fig. 1.

Note that to inspect the combustion head the burner must be moved backward and turned upward.

The maximum dimension of the burner, without casing, when open is given by measurement U-U.

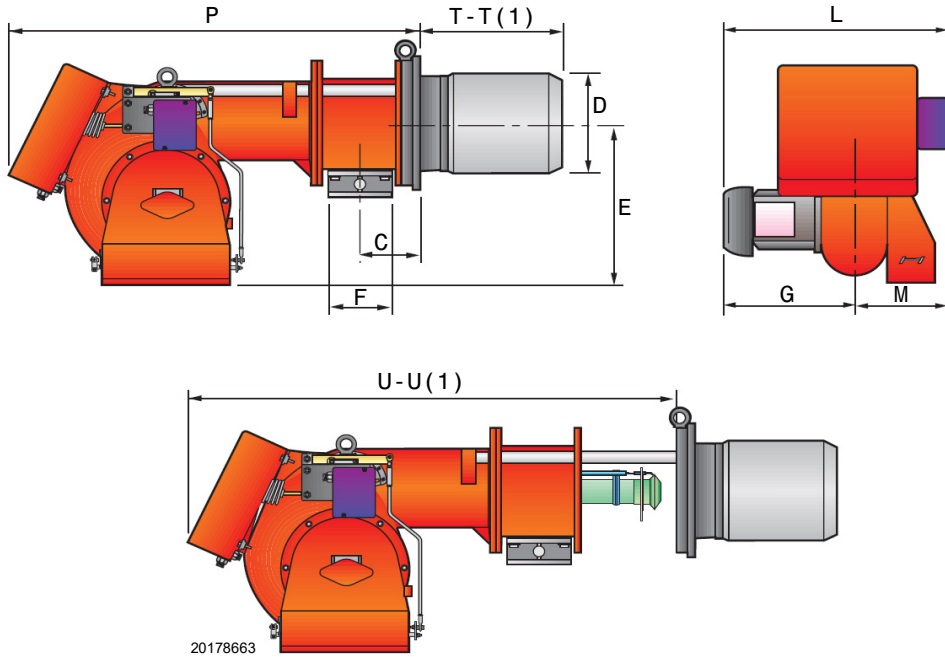

**Fig. 1**

mm	C	D	E	F	G	L	M	P	T-T (1)	U-U (1)
GAS 8 P/M	158	260	467	DN 80	396	755	359	1090	391 - 501	1541 - 1644
GAS 9 P/M	168	295	496	DN 80	498	871	373	1200	444 - 574	1627 - 1757
GAS 10 P/M	203	336	525	DN 80	508	917	409	1320	476 - 606	1730 - 1860

**Tab. C**

(1) Blast tube: short-long

**3.6 Burner equipment**

- Seal for train connection . . . . . No. 1
- Screws . . . . . No. 12
- Cable grommets for electrical cables . . . . . No. 4
- Washers . . . . . No. 8
- Extensions (only in extended head models) . . . . . No. 2
- Thermal flange gasket . . . . . No. 1
- Motor starter . . . . . No. 1
- Cable grommets for the starter electrical connections . No. 2
- Instructions . . . . . No. 1
- Spare parts list . . . . . No. 1



It is recommended to tighten the screws of the gas flange with a tightening torque of:

- DN65: **30 Nm ±10%**
- DN80: **40 Nm ±10%**
- DN100: **50 Nm ±10%**
- DN125: **60 Nm ±10%**

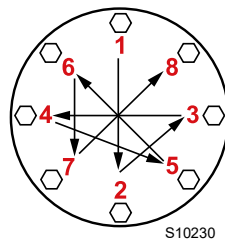

Tighten the nuts gradually (first to 30%, then to 60% up to 100%) according to the cross pattern shown in the figure.

**3.7 Firing rates**

The burner output is to be chosen from within the diagram area. This area is known as FIRING RATE and provides the burner output according to the pressure in the combustion chamber.

The work point is found by drawing a vertical line from the required output and an horizontal line from the corresponding pressure in the combustion chamber. The intersection point of the two lines is the work point, which must fall within the FIRING RATE.

**Example:**

for GAS 8 the area is delimited by:

- 1163 - 2210 kW output axis
- 0 + 14 mbar combustion chamber pressure axis
- combustion chamber maximum pressure curve.

If the burner output is 2000 kW at a pressure of 5 mbar in the combustion chamber, the work point is on the maximum pressure curve. This curve has been set with safety margins, so that all the FIRING RATE area below it can be used.

Warning:



**WARNING**

The firing rate value (Fig. 2) has been obtained considering an ambient temperature of 20 °C, an atmospheric pressure of 1013 mbar (approx. 0 m a.s.l.), and with the combustion head adjusted as shown on page 19.

The burner can operate also in depressurised combustion chambers.

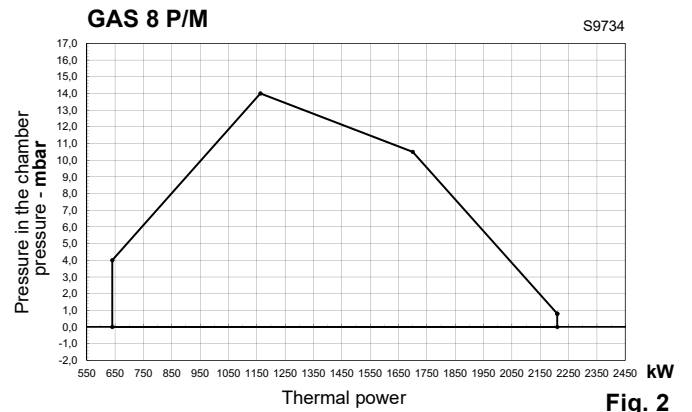

**Fig. 2**

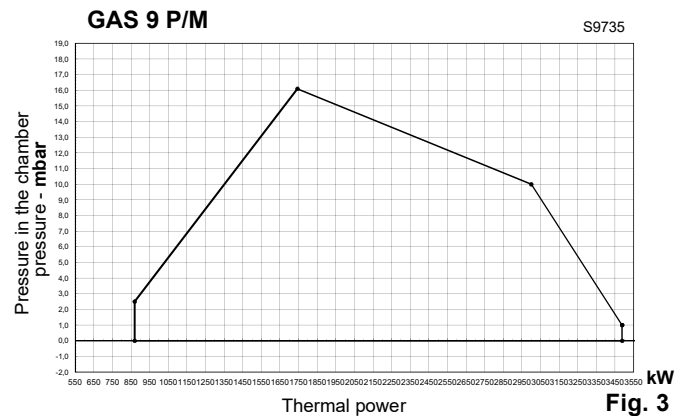

**Fig. 3**

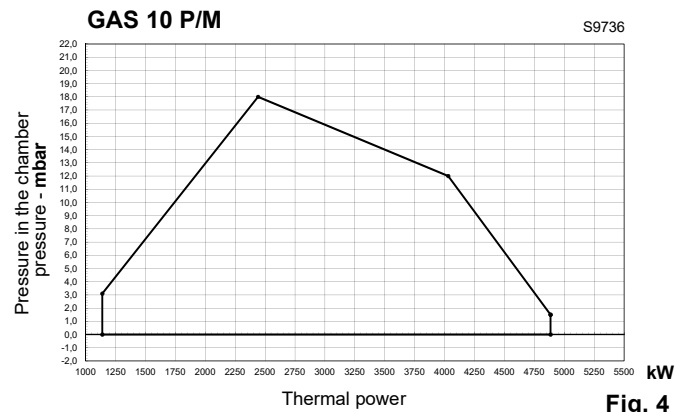

**Fig. 4**

**3.8 Test boiler**

The burner/boiler combination does not pose any problems if the boiler is EC approved and its combustion chamber dimensions are similar to those indicated in the diagram (Fig. 5).

If the burner must be combined with a boiler that has not been EC approved and/or its combustion chamber dimensions are clearly smaller than those indicated in the diagram, consult the manufacturer.

The firing rates were obtained in special test boilers, according to standard EN 676.

In Fig. 5 you can see the diameter and length of the test combustion chamber.

**Example:**

Output 1500 Mcal/h: diameter 80 cm - length 2.5 m.

**3.8.1 Commercial boilers**

The burner/boiler combination does not pose any problems if the boiler is EC approved and its combustion chamber dimensions are similar to those indicated in the diagram (Fig. 5).

If the burner must be combined with a commercial boiler that has not been EC approved (CE mark) and/or its combustion chamber dimensions are clearly smaller than those indicated in diagram (Fig. 5), consult the manufacturers.

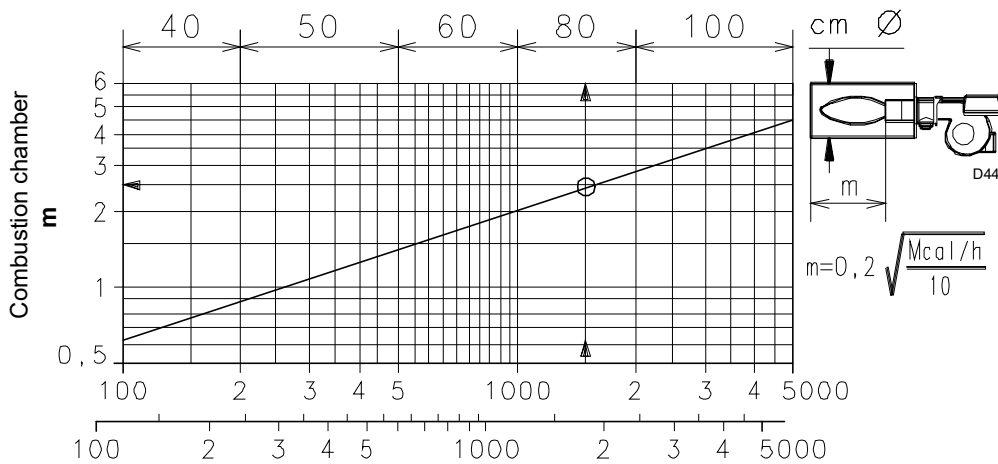

**Fig. 5**

3.9 Burner description

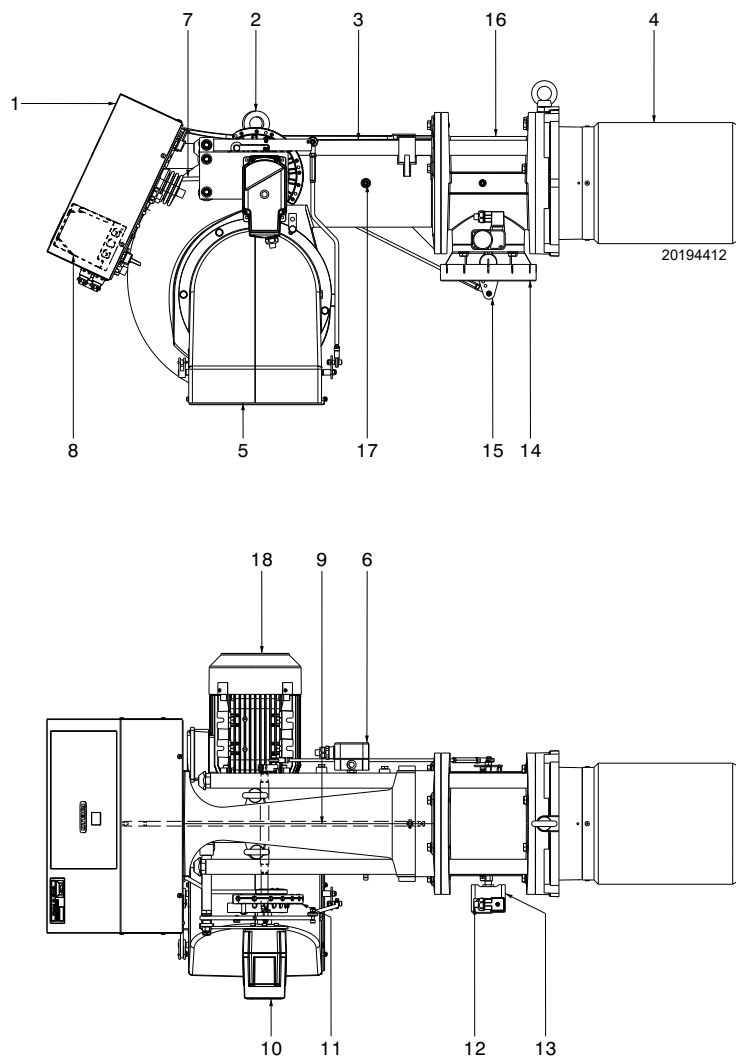

Fig. 6

- 1 Flame inspection window
- 2 Lifting rings
- 3 Slide bars for opening the burner and inspecting the combustion head (see note)
- 4 Combustion head (two lengths)
- 5 Closed air damper in stand-by to reduce heat losses
- 6 Air pressure switch
- 7 Gas butterfly valve control rod
- 8 Flame control with lockout pilot light and reset button
- 9 Combustion head control rod
- 10 Air-gas control servomotor
- 11 Air adjustment cam
- 12 Pipe coupling gas pressure test point
- 13 Maximum gas pressure switch
- 14 Butterfly valve (gas input pipe)
- 15 MIN output gas adjustment disk
- 16 Pipe coupling
- 17 Fan pressure test point
- 18 Fan motor

3.10 Electrical panel description

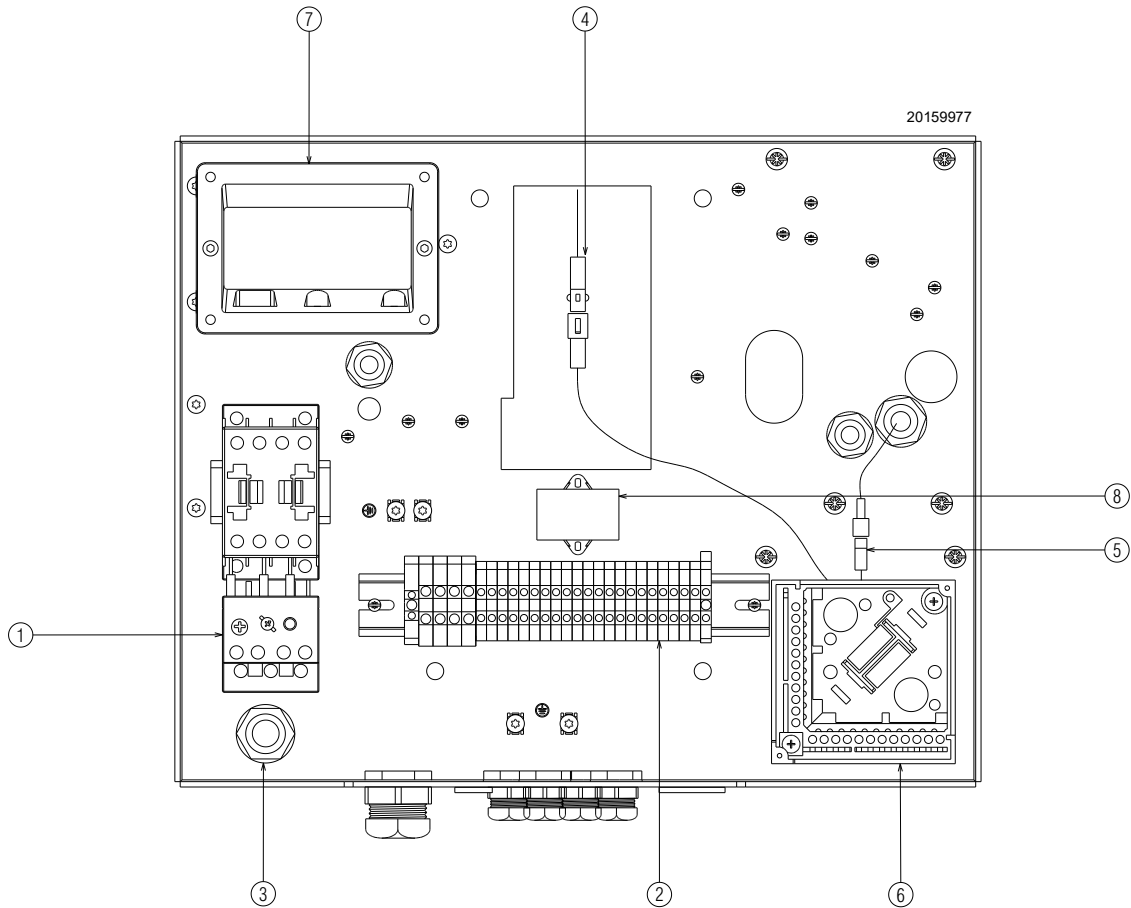

Fig. 7

- 1 Motor contactor and thermal relay (GAS 8-9 direct start-up)
- 2 Terminal board
- 3 Cable grommets supplied as standard (for electrical wirings to be carried out by the installer)
- 4 Plug-socket on ionisation probe cable
- 5 Plug-socket on servomotor cable
- 6 Flame control base
- 7 Ignition transformer
- 8 Filter to protect against radio disturbance

**3.11 Flame control (LFL...)**

**Important notes**



To avoid accidents, material or environmental damage, observe the following instructions!

The flame control LFL... is a safety device! Avoid opening or modifying it, or forcing its operation. Riello S.p.A. cannot assume any responsibility for damage resulting from unauthorised interventions!

- All interventions (assembly and installation operations, assistance, etc.) must be carried out by qualified personnel.
- Before modifying the wiring in the LFL... flame control connection area, fully disconnect the system from the power supply (omnipolar separation).
- Protection against electrocution from the flame control and all connected electric components is obtained with the correct assembly.
- Before any intervention (assembly and installation operations, assistance, etc.), ensure the wiring is in order and that the parameters are correctly set, then make the safety checks.
- Falls and collisions can negatively affect the safety functions. In this case, the flame control must not be operated, even if it displays no evident damage.
- **Do not press the reset button or the remote reset button of the flame control for more than 10 seconds because this will damage the internal relay.**

For safety and reliability, comply with the following instructions:

- Avoid conditions that can favour the development of condensate and humidity. Otherwise, before switching on again, make sure that the entire flame control is perfectly dry!
- Static charges must be avoided since they can damage the flame control's electronic components when touched.

**Use**

The LFL... flame control is a control and supervision system of medium and large capacity forced draft burners for intermittent operation (at least one controlled shutdown every 24 hours).

**Installation notes**

- Check the electrical wiring inside the boiler complies with the national and local safety regulations.
- Do not confuse the powered conductors with the neutral ones.
- Ensure that spliced wires cannot get into contact with neighbouring terminals. Use adequate ferrules.
- Arrange the H.V. ignition cables separately, as far as possible from the flame control and the other cables.
- When wiring the unit, make sure that AC 230 V mains voltage cables are run strictly separate from extra low-voltage cables to avoid risks of electrical shock hazard.

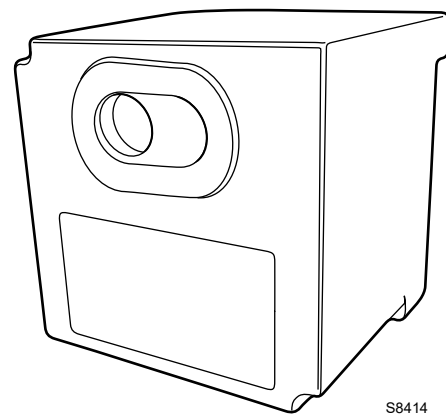

**Fig. 8**

**Electrical wiring of the flame detector**

It is important for signal transmission to be almost totally free of any disturbances or loss:

- Always separate the detector cables from the other cables:
  - The capacitive reactance of the line reduces the size of the flame signal.
  - Use a separate cable.
- Respect the allowed cable lengths.
- The ionisation probe is not protected against the risk of electrocution. When connected to the electricity supply, the ionisation probe must be protected against any accidental contact.
- Position the ignition electrode and the ionisation probe so that the ignition spark cannot form an arc on the probe (risk of electric overcharge).

**Technical data**

Mains voltage	AC 230 V -15 % / +10 %
Mains frequency	50 / 60 Hz ±6 %
Fuse (Internal)	T6.3H250V
Primary fuse (external)	max. 10 A
Weight	approx. 1 kg
Power absorption	approx. AC 3.5 VA
Protection level	IP40
Safety class	II
Input current at terminal 1	max. 5 A continuous (peaks of 20 A / 20 ms)
Load on the control terminals	max. 4 A continuous (peaks of 20 A / 20 ms)
<b>Environmental conditions</b>	
Operation	DIN EN 60721-3-1
Climatic conditions	Class 1K3
Mechanical conditions	Class 1M2
Temperature range	-20...+60°C
Humidity	< 95% RH

**Tab. D**

## 3.12 Servomotor SQM40 ...

## Important notes



To avoid accidents, material or environmental damage, observe the following instructions!

Avoid opening, modifying or forcing the servomotor.

- All interventions (assembly and installation operations, assistance, etc.) must be carried out by qualified personnel.
- Falls and collisions can negatively affect the safety functions. In this case, the servomotor must not be operated, even if it displays no evident damage.
- Fully disconnect the burner from the mains when working near terminals and servomotor connections.
- Condensation and exposure to water are not allowed.
- For safety reasons, the servomotor must be checked after long periods of non-use.



Fig. 9

## Technical data

Mains voltage	230 V -15% +10%
Mains frequency	50 / 60 Hz
Power absorption	10 VA
Motor	Synchronous
Drive angle	Varying between 0° and 135°
Protection level	Max. IP 66, with appropriate cable entry
Cable entry	2 x M20
Cable connection	terminal board for 0.5 mm <sup>2</sup> (min.) and 2.5 mm <sup>2</sup> (max)
Rotation direction	Anticlockwise
Rated torque (max.)	10 Nm
Holding torque	5 Nm
Operation time	30 s. at 90°
Weight	approx. 2 kg
Environmental conditions:	
Operation	-20...+60° C
Transport and storage	-20...+60°C

Tab. E

**4 Installation**

**4.1 Notes on safety for the installation**

After carefully cleaning all around the area where the burner is to be installed, and arranging for the environment to be illuminated correctly, proceed with the installation operations.



All the installation, maintenance and disassembly operations must be carried out with the electricity supply disconnected.



The installation of the burner must be carried out by qualified personnel, as indicated in this manual and in compliance with the standards and regulations of the laws in force.



The combustion air inside the boiler must be free from hazardous mixes (e.g.: chloride, fluoride, halogen); if present, it is highly recommended to carry out cleaning and maintenance more frequently.

**4.2 Handling**

The burner packaging includes a wooden platform, it is therefore possible to handle the burner (still packaged) with a pallet truck or fork lift truck.



Burner handling operations can be highly dangerous if not carried out with the greatest attention: distance unauthorised personnel, check integrity and suitability of the means available. Check also that the area in which you are working is empty and that there is an adequate escape area (i.e. a free, safe area to which you can quickly move if the burner should fall). During handling, keep the load at no more than 20-25 cm from the ground.

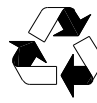

After positioning the burner near the installation point, correctly dispose of all residual packaging, separating the various types of material.



Before proceeding with the installation operations, carefully clean all around the area where the burner will be installed.

**4.3 Preliminary checks**

**Checking the consignment**



After removing all the packaging, check the integrity of the contents. In the event of doubt, do not use the burner; contact the supplier.



The packaging elements (wooden cage or cardboard box, nails, clips, plastic bags, etc.) must not be abandoned as they are potential sources of danger and pollution; they should be collected and disposed of in the appropriate places.

		A			B	
		D		C	F	
		E			G	
GAS-KAASU <input checked="" type="checkbox"/> FAM.2		G			H	
GAZ-AEPIO <input type="checkbox"/> FAM.3		G			H	
I		I	I	I	I	I
					CE	
						

20187902

**Fig. 10**

**Checking the characteristics of the burner**

Check the identification label of the burner (Fig. 10), showing:

- A** the burner model
- C** the cryptographic year of manufacture
- D** the serial number
- E** the data for electrical supply and the protection level
- F** the electrical power consumption
- G** the types of gas used and the relevant supply pressures
- H** the data of the burner possible minimum and maximum output (see Firing rate).  
**Warning.** The burner output must be within the firing rate of the boiler;
- I** the category of the appliance/countries of destination.



A burner label that has been tampered with, removed or is missing, along with anything else that prevents the definite identification of the burner makes any installation or maintenance work difficult

**4.4 Operating position**



- The burner is set up to operate only in positions **1, 2, 3** and **4** (Fig. 11).
- Installation **1** is preferable, as it is the only one that allows the maintenance operations as described in this manual.
- Installations **2, 3** and **4** permit operation but make maintenance and inspection of the combustion head more difficult.



- Any other position could compromise the correct operation of the appliance.
- Installation **5** is forbidden for safety reasons.

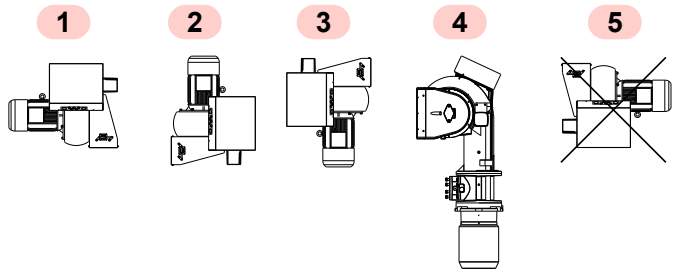

**Fig. 11**

**4.5 Preparing the boiler**

**4.5.1 Boring the boiler plate**

Pierce the closing plate of the combustion chamber, as in Fig. 12. The position of the threaded holes can be marked using the thermal insulation screen supplied with the burner.

mm	D1	DF	Ø
GAS 8 P/M	265	368	M16
GAS 9 P/M	300	368	M18
GAS 10 P/M	350	438	M20

**Tab. F**

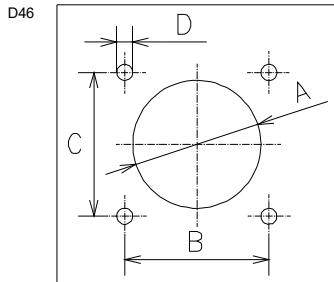

**Fig. 12**

**4.5.2 Blast tube length**

The length of the blast tube must be selected according to the indications provided by the manufacturer of the boiler, and in any case it must be greater than the thickness of the boiler door complete with its fettling. The range of lengths available, L (mm), is as follows:

Blast tube L mm	GAS 8 P/M	GAS 9 P/M	GAS 10 P/M
Extended head	501	574	606
Short head	391	444	476
Short head plus spacer	281	314	346

**Tab. G**

For boilers with front flue passes 9)(Fig. 13 on page 17), or flame inversion chamber, a protection in refractory material 7) must be inserted between the boiler fettling 8) and the blast tube 6).

This protection must not compromise the extraction of the blast tube.

**4.5.3 Securing the burner to the boiler**



Provide an adequate lifting system.

- Separate the combustion head as shown:
  - Remove the screws 5)(Fig. 13) from the two slide bars 6).
  - Remove the pin 2) and disengage the head control rod 11).
  - Remove the screw 3) and disengage the gas butterfly valve control rod 4).
  - Remove the screws 7) securing the fan to the combustion head.
  - Draw the burner back by about 100-120 mm.
  - Remove the screws 12) and disengage the shifting fork 8).
  - Now remove the burner from the slide bars 6) completely; by removing the burner, also the gas tube 9) will slide out of the elbow 10).
- Before securing the combustion head to the boiler, make sure the probe and electrode are positioned correctly as in (Fig. 14 on page 18). If the position is incorrect, remove the elbow 10)(Fig. 13) from the pipe coupling 13).



**CAUTION**

Do not rotate the probe but leave it as in Fig. 14; if it is too close to the ignition electrode, it could damage the flame control amplifier.

- Fix the blast tube to the boiler plate (Fig. 12 on page 16), inserting the supplied insulating flange gasket 14)(Fig. 13).
- Use the 4 screws, also supplied, after protecting their thread with anti-locking product.
- The seal between burner and boiler must be airtight.
- Adjust the combustion head as described below.
- Then refit the burner on the slide bars 6)(Fig. 13) and the gas tube 9) into the elbow 10).
- Leave the burner open by about 100-120 mm.
- Refit the fork 8)(Fig. 13) fixing it with the screws 12).
- Close the burner.
- Tighten the screws 7)(Fig. 13) securing the fan to the combustion head.
- Fit the retainers and the screws 5)(Fig. 13) to the two slide bars 6).
- Engage the rods 4) and 11) again.

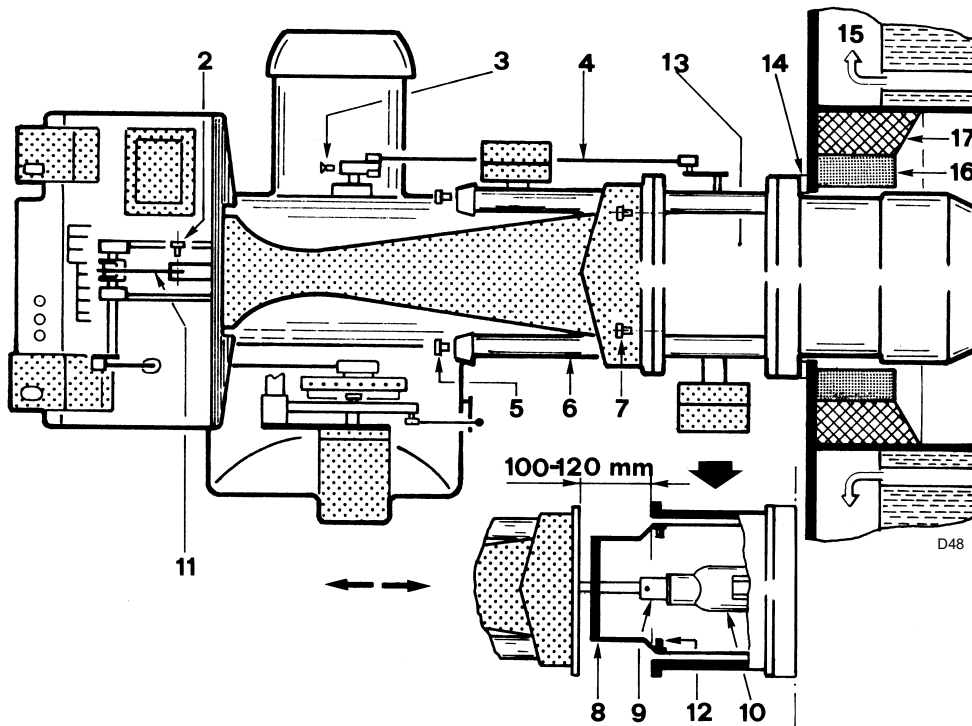

Fig. 13



**WARNING**

The seal between burner and boiler must be airtight.

## 4.6 Positioning the probe - electrode



WARNING

Before securing the burner to the boiler, check (through the opening of the blast tube) that the probe and electrode are correctly positioned, as in Fig. 14.

If in the previous check the position of the probe or electrode was not correct, remove the screws 7)(Fig. 13 on page 17) extract the inner part of the head 4)(Fig. 6 on page 11), and adjust them.



WARNING

Do not rotate the probe but leave it as in Fig. 14; if it is too close to the ignition electrode, it could damage the flame control amplifier.



WARNING

Respect the dimensions shown in Fig. 14.

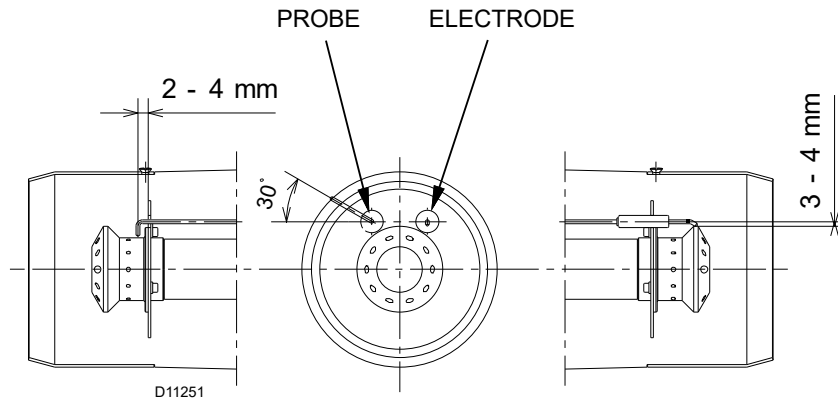

Fig. 14

**4.7 Combustion head adjustment**

The adjustment of the combustion head depends only on the MIN and MAX output of the burner.

Therefore, these two values must be set before adjusting the combustion head.

The head must not be adjusted if in the final set-up the preset MIN and MAX output values are slightly changed.

Two combustion head adjustments are available:

- One fixed gas delivery adjustment carried out with the burner open while securing the burner to the boiler page 17.
- One movable adjustment both for gas and air deliveries carried out with the burner closed, as described in page 26.



The notch number is the same for gas and air and can be obtained from the diagram (Fig. 15) according to the burner output.

**4.7.1 Fixed gas delivery adjustment**

- Loosen the screw 1)(Fig. 16)
- Turn the ring nut 2) so that the index 3) matches the required notch 4)
- Lock the screw 1)

The notch must be chosen from the diagram (Fig. 15) according to the MAX output required for the burner operation.

**Example:**

GAS 8 P/M MAX thermal power 1,500 Mcal/h.

NOTCH: 4



When fitting the burner on the two slide bars, it is advisable to gently draw out the high voltage cable and the flame detection probe cable until they are slightly stretched.

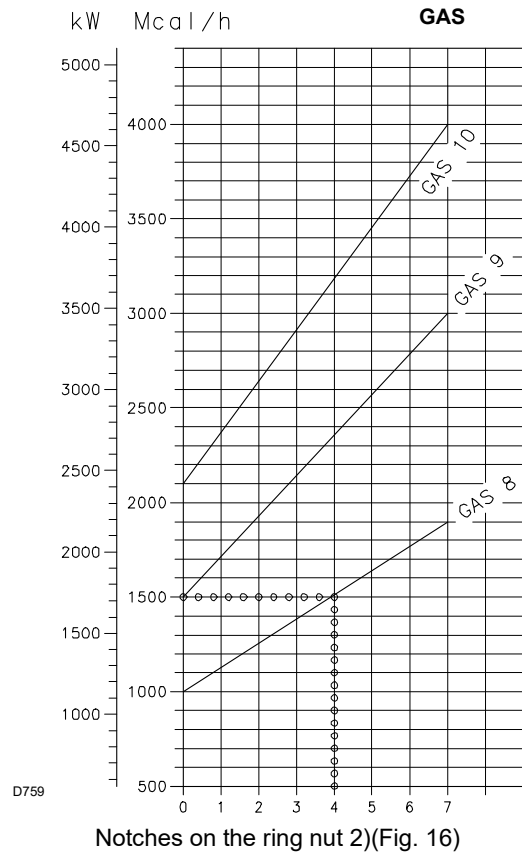

Fig. 15

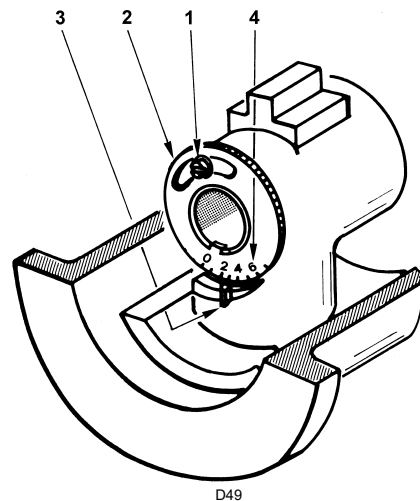

Fig. 16

**4.8 Gas supply**



Explosion danger due to fuel leaks in the presence of a flammable source.

Precautions: avoid knocking, attrition, sparks and heat.

Make sure the fuel shut-off valve is closed before performing any operation on the burner.



The fuel supply line must be installed by qualified personnel, in compliance with current standards and laws.

**4.8.1 Gas feeding line (Example) - Please refer to the gas train documentation for more information**

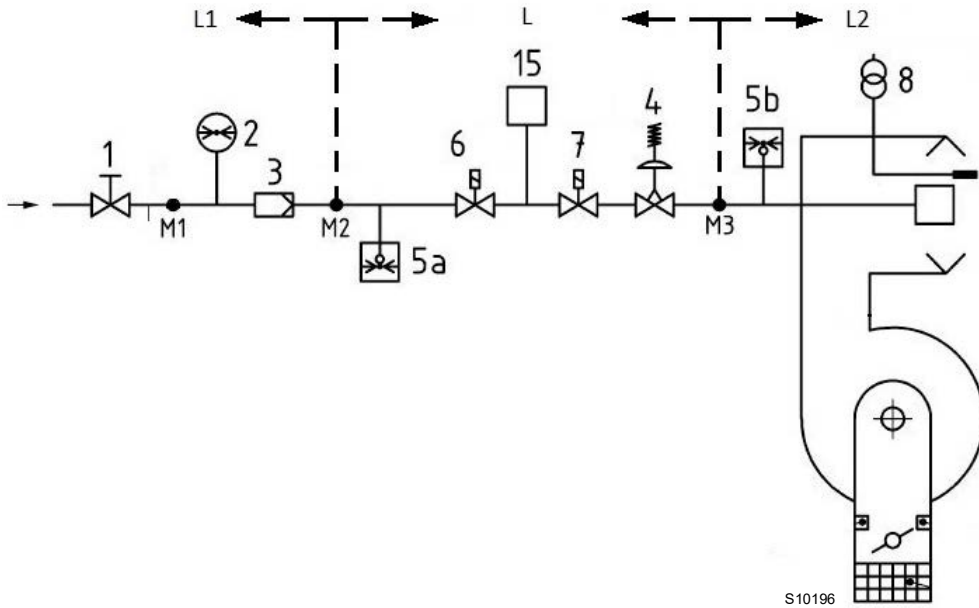

S10196

**Fig. 17**

Key (Fig. 17)

- 1 Manually operated shut-off valve
- 2 Pressure gauge
- 3 Filter
- 4 Governor
- 5a Low pressure protection device
- 5b Maximum gas pressure switch
- 6 1st safety shut-off device
- 7 2nd safety shut-off device
- 8 Ignition device
- 15 Valve leak detection control system
- L Gas train (supplied separately)
- L1 Responsibility of the installer
- L2 Burner
- M1 Pressure test point
- M2 Pressure test point
- M3 Pressure test point

**4.8.2 Gas train**

Type-approved in accordance with EN 676 and supplied separately from the burner.

**4.8.3 Gas train installation**



Disconnect the electrical power supply using the system main switch.



Check that there are no gas leaks.



Pay attention when handling the train: danger of crushing of limbs.



Make sure that the gas train is properly installed by checking for any fuel leaks.



The operator must use the required equipment during installation.

The train can enter the burner from the right or left side, depending on which is the most convenient, see Fig. 6.

**4.8.4 Gas pressure**

Tab. H indicates the pressure drops of the combustion head and gas butterfly valve, on the basis of the burner operating output.

Model	kW	1 Δp (mbar)	
		G20	G25
GAS 8 P/M	1150	0,59	0,87
	1300	0,75	1,11
	1450	0,93	1,38
	1600	1,14	1,69
	1750	1,36	2,01
	1900	1,60	2,37
	2050	1,86	2,75
	2200	2,15	3,18
GAS 9 P/M	1800	1,41	2,09
	2000	1,74	2,58
	2200	2,11	3,12
	2400	2,51	3,71
	2600	2,94	4,35
	2800	3,42	5,06
	3000	3,92	5,80
	3200	4,46	6,60
	3400	5,04	7,46
	3500	5,33	7,89
GAS 10 P/M	2500	1,08	1,60
	2800	1,35	2,00
	3100	1,65	2,44
	3400	1,99	2,95
	3700	2,35	3,48
	4000	2,75	4,07
	4300	3,18	4,71
	4600	3,64	5,39
4900	4,13	6,11	

**Tab. H**



**Data of head thermal power and gas pressure refer to operation with gas butterfly valve fully open (90°).**

The values shown in Tab. H refer to:

- Natural gas G 20 NCV 10 kWh/Sm<sup>3</sup> (8.6 Mcal/Sm<sup>3</sup>)
- Natural gas G 25 NCV 8.6 kWh/Sm<sup>3</sup> (7.4 Mcal/Sm<sup>3</sup>)

Column 1

Combustion head pressure drop.

Gas pressure measured at test point 12)(Fig. 6 on page 11), with:

- combustion chamber at 0 mbar;
- Gas G20 (natural gas)

To calculate the approximate output at which the burner operates:

- subtract the combustion chamber pressure from the gas pressure measured at test point 12) (Fig. 6 on page 11).
- Find in Tab. H related to the burner concerned, the pressure value closest to the result of the subtraction.
- Read the corresponding output on the left.

**Example GAS 9 P/M with natural gas G20:**

Gas pressure at test point	=	13 mbar
Pressure in combustion chamber	=	3 mbar
13 - 3	=	10 mbar

corresponding to a maximum output of 2900 kW in the diagram of GAS 9 P/M. This value serves as a rough guide; the effective output must be measured at the gas meter.

To calculate the required gas pressure at test point 12) (Fig. 6 on page 11), set the output required from the burner operation:

- find the nearest output value in Tab. H for the burner in question.
- Read, on the right (column 1), the pressure at the test point 12)(Fig. 6 on page 11).
- Add this value to the estimated pressure in combustion chamber.

**Example GAS 9 P/M with natural gas G20:**

Required output: 2900 kW

Gas pressure at an output of 2900 kW	=	10 mbar
Pressure in combustion chamber	=	3 mbar
10 + 3	=	13 mbar

pressure required at test point 12)(Fig. 6 on page 11).

**4.9 Electrical connections**

**Notes on safety for the electrical wiring**



- The electrical wiring must be carried out with the electrical supply disconnected.
- Electrical wiring must be made in accordance with the regulations currently in force in the country of destination and by qualified personnel. Refer to the wiring diagrams.
- The manufacturer declines all responsibility for modifications or connections different from those shown in the wiring diagrams.
- Check that the electrical supply of the burner corresponds to that shown on the identification label and in this manual.
- The burner has been type-approved for intermittent use. This means they should compulsorily be stopped at least once every 24 hours to enable the flame control to perform checks of its own start-up efficiency. Normally, burner stopping is guaranteed by the boiler's thermostat/pressure switch.
- If this is not the case, a time switch should be fitted in series to TL to stop the burner at least once every 24 hours. Refer to the wiring diagrams.
- The electrical safety of the device is obtained only when it is correctly connected to an efficient earthing system, made according to current standards. It is necessary to check this fundamental safety requirement. In the event of doubt, have the electrical system checked by qualified personnel. Do not use the gas tubes as an earthing system for electrical devices.
- The electrical system must be suitable for the maximum power absorption of the device, as indicated on the label and in the manual, checking in particular that the section of the cables is suitable for that level of power absorption.
- For the main power supply of the device from the electricity mains:
  - do not use adapters, multiple sockets or extensions;
  - make provisions for an omnipolar switch with a gap between the contacts of at least 3 mm (over-voltage category III), as required by current safety regulations.
- Do not touch the device with wet or damp body parts and/or in bare feet.
- Do not pull the electric cables.

Before carrying out any maintenance, cleaning or checking operations:

The use of the cable grommets and the pre-blanked holes can be done in different manners; for example:



Disconnect the electrical supply from the burner by means of the system main switch.



Close the fuel shut-off valve.



Avoid condensate, ice and water leaks from forming.

Use flexible cables according to EN 60 335-1 Regulations:

- if in PVC sheath, use at least H05 VV-F
- if in rubber sheath, use at least H05 RR-F.

All the cables to be connected to the terminal board of the burner are passed through cable grommets, as indicated in Fig. 18.

**NOTE:**

**TR and TL remote controls are not necessary when RWF50 regulator is used for modulating operation; their function is carried out by the regulator itself.**

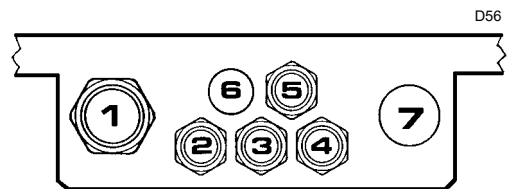

**Fig. 18**

- |   |         |   |
|---|---------|---|
| 1 | Pg 29   | Three-phase power supply (from the mains or from star/triangle starter) |
| 2 | Pg 13.5 | Single-phase power supply   |
| 3 | Pg 13.5 | TR and TL remote control or probe (RWF50)                               |
| 4 | Pg 13.5 | Gas valves  |
| 5 | Pg 13.5 | VPS Valve leak test   |
| 6 | Pg 13.5 | Hole for RWF50 pipe union   |
| 7 | Pg 29   | Hole for pipe union, if any   |



After carrying out maintenance, cleaning or checking operations, reassemble the cover and all the safety and protection devices of the burner.

### 4.10 Calibration of the thermal relay (only model GAS 8-9 P/M)

The thermal relay (Fig. 19) serves to avoid damage to the motor due to an excessive absorption increase or if a phase is missing. For calibration 2), refer to the table indicated in the electrical layout (electrical wiring by the installer).

To reset, in case of thermal relay activation, press the "RESET" button 1).

The button "STOP" 3) opens the NC contact (95-96) and stops the motor.

Insert a screwdriver in the window "TEST/TRIP" 4) and move it in the arrow direction (to the right) to carry out the thermal relay test.

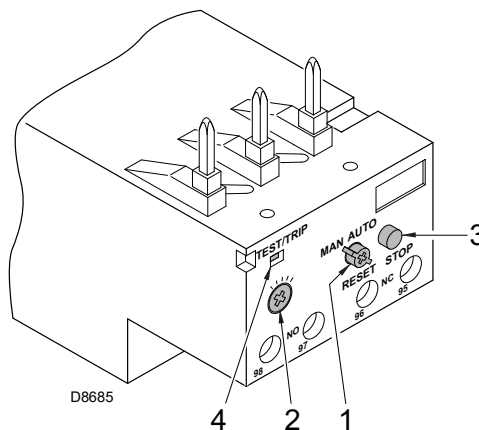

Fig. 19



**WARNING**

The automatic reset can be dangerous.

This operation is not foreseen in the burner operation.

### 4.11 Motor rotation

As soon as the burner starts, place yourself in front of the cooling fan of the fan motor and check that it turns anticlockwise.

If this is not the case:

- put the switch of the burner to "0" (off) and wait until the flame control carries out the switching off phase.



**DANGER**

Disconnect the electrical supply from the burner by means of the system main switch.

- Invert the phases on the three-phase motor power supply.

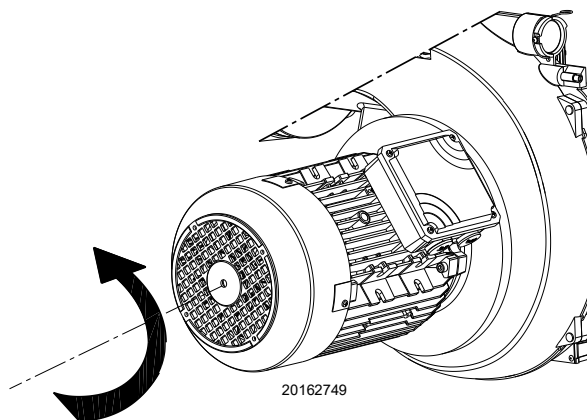

Fig. 20

## 5 Start-up, calibration and operation of the burner

### 5.1 Notes on safety for the first start-up



WARNING

The first start-up of the burner must be carried out by qualified personnel, as indicated in this manual and in compliance with the standards and regulations of the laws in force.



WARNING

Before starting up the burner, refer to section "Safety test - with no gas supply" on page 35.



WARNING

Check the correct working of the adjustment, command and safety devices.

### 5.2 Adjustments prior to ignition

Open the manual valves upstream of the gas train:

- adjust the minimum gas pressure switch to the start of the scale (Fig. 30 on page 32).
- Adjust the maximum gas pressure switch to the end of the scale (Fig. 31 on page 32).
- Adjust the air pressure switch to the start of the scale (Fig. 32 on page 32).
- Purge the air from the gas line.
- We recommend using a plastic tube routed outside the building and to purge air until gas is smelt.
- Fit a U-type pressure gauge (Fig. 21) to the gas pressure test point on the pipe coupling.
- It is used to calculate approximate MAX burner output using the diagrams on page 18
- Connect two lights or testers in parallel to the two gas line solenoid valves VR and VS in order to check the exact moment at which voltage arrives.
- This operation is not required if each of the two solenoid valves is equipped with a pilot light that signals voltage passing through.
- Do not perform any operation on the gas butterfly valve, which must be closed (index at 0°) with the burner off.
- Do not perform any operation on air damper and combustion head.



CAUTION

Before starting up the burner, it is good practice to adjust the gas train so that ignition takes place in conditions of maximum safety, i.e. with gas delivery at the minimum.

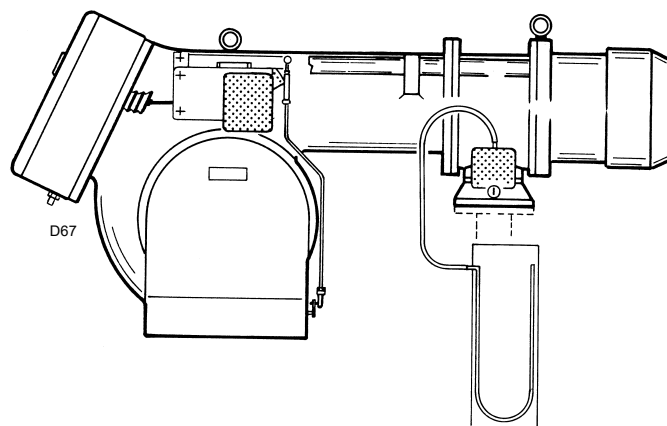

Fig. 21

### 5.3 Burner start-up

Close the remote controls and turn:

As soon as the burner starts, check that the lamps or the testers connected to the solenoid valves or the warning lights on the solenoid valves indicate no voltage presence.

If they indicate the presence of voltage, stop the burner **immediately** and check the electric connections.

### 5.4 Burner ignition

Once the above steps are completed, the burner should ignite.

If the motor starts but the flame does not appear and the flame control goes into lockout, reset and wait for a new ignition attempt.

If ignition does not occur, it is possible that gas is not reaching the combustion head within the safety time period of 3 seconds. Therefore, it is necessary to increase gas ignition delivery.

The arrival of gas to the sleeve is indicated by the U-type pressure gauge (Fig. 21).

Once ignition has taken place, proceed with burner global calibration operations.



WARNING

In the event the burner stops, in order to prevent any damage to the installation, do not unblock the burner more than twice in a row. If the burner locks out for a third time, contact the customer service.



DANGER

In the event there are further lockouts or faults with the burner, the maintenance interventions must only be carried out by qualified, authorised personnel, in accordance with the contents of this manual and in compliance with the standards and regulations of current laws.

**5.5 Burner adjustment**

The optimum adjustment of the burner requires an analysis of flue gases at the boiler outlet.

Adjust in sequence:

- 1 Combustion head
- 2 Servomotor
- 3 Output upon ignition
- 4 Preliminary calibrations, if necessary
- 5 MAX output
- 6 MIN output
- 7 Intermediate outputs between the two
- 8 Air pressure switch
- 9 Maximum gas pressure switch
- 10 Minimum gas pressure switch

**5.5.1 Combustion head**

The fixed gas delivery adjustment has been carried out, see page 19. Now it is necessary to carry out the movable adjustment which concerns both gas and air deliveries at the same time.

Please remember that this adjustment depends only on the MIN and MAX outputs required for the burner operation.

**Movable gas-air delivery adjustment (Fig. 22) - (Fig. 23 on page 27)**

It consists of a forward-backward movement of the two shutters located in the combustion head.

The two shutters, moved by the servomotor 10)(Fig. 6 on page 11) together with the gas butterfly valve and the air damper, vary the gas and air outlet sections.

When the burner output switches from MAX to MIN, the two shutters reduce the outlet sections and keep the gas and air pressures at an optimal value. In this way, a high combustion efficiency is ensured even with low deliveries.

The reverse movement is obtained when the output is switched from MIN to MAX.

The position of the two shutters is indicated by the notch on the graduated cylinder 2)(Fig. 23 on page 27) referred to plane 10). Notch 0: min. opening; notch 9: max. opening. The control levers operate simultaneously on both shutters. They are factory set for the maximum 9-notch stroke, movement of cylinder 2) from notch 0 to notch 9, suitable to obtain the maximum output variation when the burner is operating: approx. 1-4.

For a lower MIN-MAX ratio, the levers must be recalibrated in such a way that the stroke of the cylinder 2) is performed between the two notches related to the required outputs, which can be obtained from the diagram (Fig. 22).

For example:

with GAS 8 P/M for an output variation between 750 (MIN) and 1,500 (MAX) Mcal/h, the cylinder 2) must move from the notch 1.5 (MIN) to the notch 7.2 (MAX) with a stroke of 5.7 notches.

To change the stroke of the cylinder 2) it must be considered that the rod 1)(Fig. 23 on page 27) driving the push-rod 8) features a slot: moving the articulated coupling 9) towards the slot outer side will shorten the stroke of the cylinder 2) by up to 4 notches.

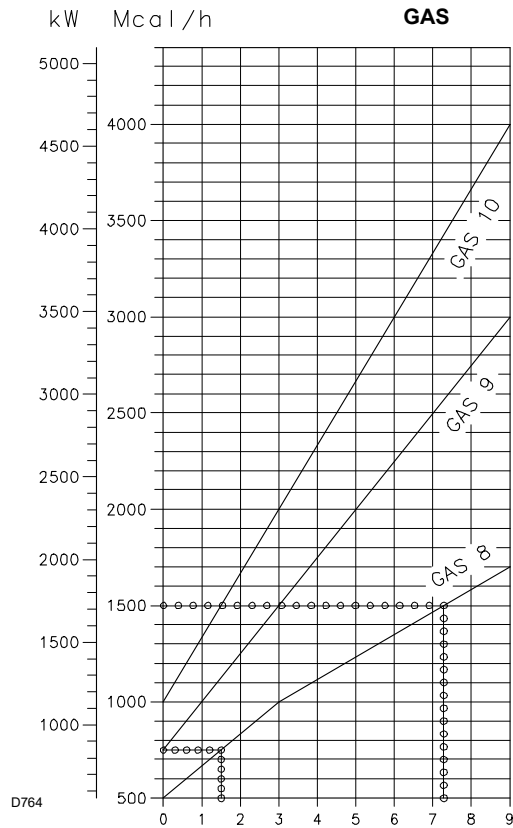

Notches on the ring nut 2)(Fig. 16)

**Fig. 22**

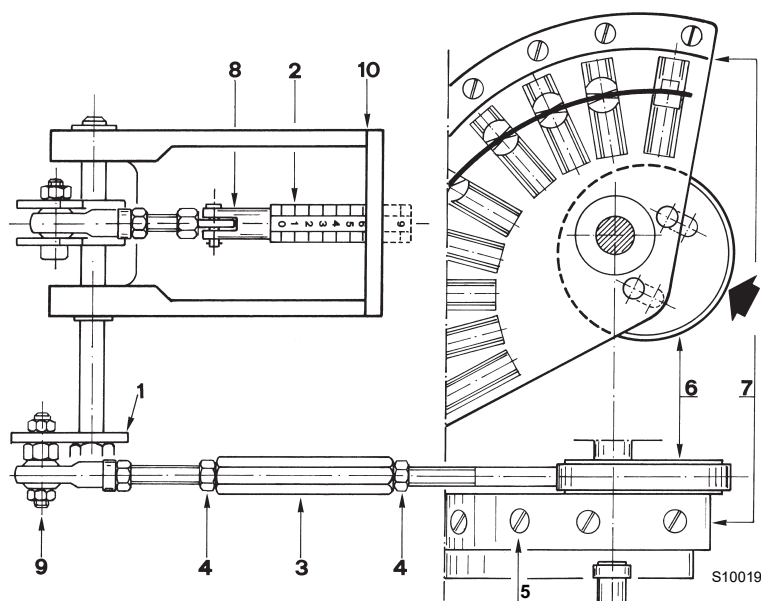

Fig. 23

Proceed as follows (with burner off):

- use the diagram to calculate the notches relating to the required MIN and MAX outputs (Fig. 22), as well as the stroke of the cylinder 2)(Fig. 23):
  - MAX notch - MIN notch.
- Release the variable profile cam 7)(Fig. 23) from the servomotor by pressing the lever 9)(Fig. 27 on page 29).
- Manually rotate the cam 11)(Fig. 6 on page 11) from 0° to 130°.
- Check the stroke of the cylinder 2)(Fig. 23) referring to the plane 10)(Fig. 23).
- If the stroke is greater than indicated by the diagram (Fig. 22 on page 26), loosen the nut fixing the articulated coupling 9)(Fig. 23), move the articulated coupling along the slot with subsequent attempts until, with the complete rotation from 0° to 130° of cam 7)(Fig. 23), the required stroke is obtained on the plane 10)(Fig. 23).
- Lock the articulated coupling fixing nut.

If with the articulated coupling 9)(Fig. 23) at the end of the slot, the required stroke reduction is not obtained, proceed as follows:

- Manually bring the servomotor back to 0°.
- Loosen the Allen screws 5) retaining the servomotor shaft eccentric.
- Push the ring 6) in the direction indicated by the arrow in order to reduce the eccentricity and thus the stroke of the shaft 8).
- Once the required stroke is obtained, position the servomotor to 0°. Check whether the notch of the cylinder 2) on the reference plane 10) corresponds to the required MIN value, if not:
  - Loosen the nuts 4).
  - Turn the hexagonal pipe coupling 3) to shorten or lengthen the rod, until the minimum notch value collimates on the plane 10).
  - Lock the nuts 4).
- By manually rotating the cam 7)(Fig. 23) from 0° to 130°, check the absence of jamming during the movement and that the MIN and MAX notches correspond to the indications found in the diagram (Fig. 22 on page 26).

### 5.6 Servomotor adjustment

The servomotor adjusts simultaneously, through driving gears, the output and pressure of the air and the delivery of the fuel in use. It performs a 135° rotation in 45s. After the adjustment made in the factory to its 6 cams to allow an initial ignition.

Check that they are as shown below.

In the event of a modification, follow what is described below for each cam:

**Cam I (RED):**                    **130°** (The same for all models).  
Limits rotation toward maximum position.



**Do not alter the factory setting.**

**Cam II (BLUE):**                    **0°** (The same for all models).  
Limits rotation toward minimum position. With the burner off, the air damper is completely closed: 0°



It is recommended that no adjustments are made.

**Cam III (ORANGE):**                **20°** (The same for all models).  
Adjusts the position of ignition and minimum output of gas fuel.

**Cam IV (YELLOW):**                Not used

**Cam V (BLACK):**                    Not used

**Cam VI (GREEN):**                    Not used

#### 5.6.1 Output upon ignition



For safety purposes and correct product operation, the ignition output, if it is adjustable, must be carried out by authorized personnel and in compliance with the standards and regulations of the laws in force.

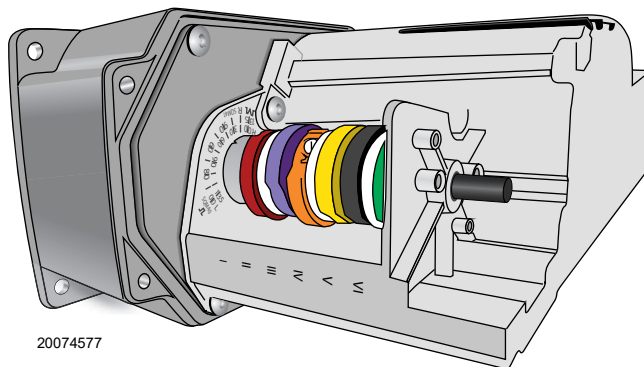

**Fig. 24**

5.6.2 Preliminary calibrations, if necessary

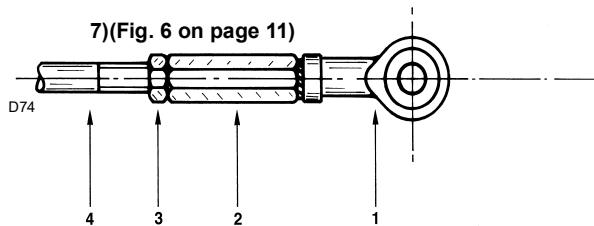

Fig. 25

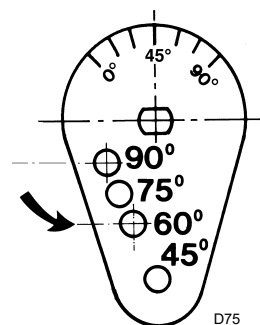

Fig. 26

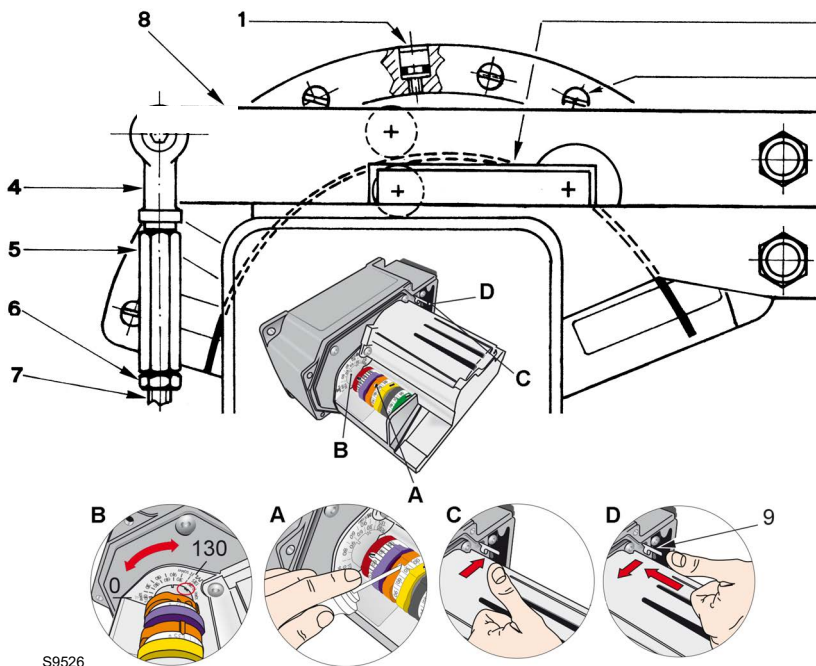

Fig. 27

They concern the disc (Fig. 26) of the gas butterfly valve, the tie-rod (Fig. 25) controlling the disc (Fig. 26) and the tie-rod 7)(Fig. 27) controlling the air damper.

Their calibration depends on the MIN and MAX outputs required for the burner operation.

- The burner is factory set for a MIN-MAX output ratio of 1:3 - 1:4. The articulated coupling 1)(Fig. 25) controlling the disc (Fig. 26) of the gas butterfly valve is positioned at 90°. In this way the gas butterfly valve turns by 90° when the cam 2)(Fig. 27) covers the whole angle of 130° (A) (Fig. 28).

When the MIN-MAX ratio is approximately 1:2, the articulated coupling 1)(Fig. 25) must be moved from 90° hole to 60° hole (Fig. 26), with the burner off.

In this case the gas butterfly valve turns by 60° when the cam 2)(Fig. 27) covers the whole angle of 130° (B) (Fig. 28). On the disc (Fig. 26) there are two additional holes, 75° and 45°, that can be used in special cases, when the working angle of the butterfly valve is to be reduced in the presence of a higher gas pressure upstream of the butterfly valve itself.

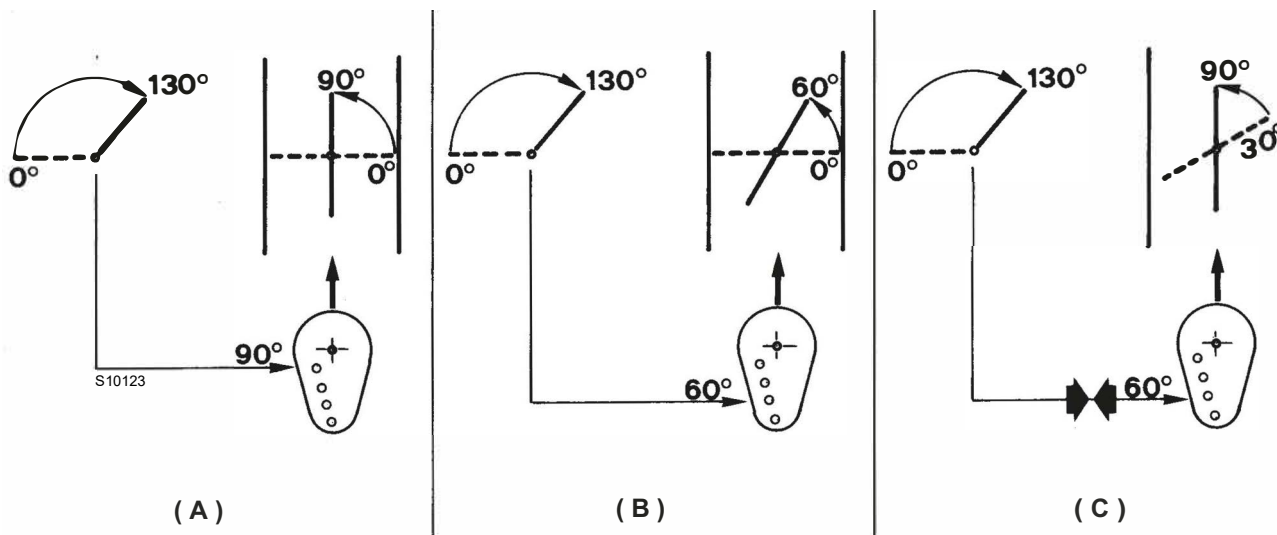

Fig. 28

- If the 1-2 ratio falls within the highest output range (e.g. 40-80% of the MAX burner output), it is necessary, apart from moving the articulated couplings from 90° to 60°, to shorten the tie-rod (Fig. 25) and rotate the working angle of the gas butterfly valve so that the maximum opening is 90°: from 0 - 60°(B) to 30 - 90°(C)(Fig. 28).

In this case the gas butterfly valve remains partially open, index at about 30°, with the burner in stand-by mode.

- To shorten the tie-rod, proceed as follows, with the burner off:
- Disengage the articulated coupling 1)(Fig. 25 on page 29) from the disc (Fig. 26 on page 29).
  - Loosen the nuts 3)(Fig. 25 on page 29).
  - Tighten the hexagon 2) by a few turns.
  - Lock the nut 3).
  - Reconnect the articulated coupling 1)(Fig. 25 on page 29) to the disc (Fig. 26 on page 29).
- If the 1-2 ratio falls within the lowest output range (e.g. 25-50% of the MAX burner output), lengthen the tie-rod 7)(Fig. 27) controlling the air damper. In this way, a too curved cam profile can be avoided.

- With the burner off, proceed as follows (Fig. 27 on page 29):
- Disengage the articulated coupling 4) from the lever 9)(Fig. 27 on page 29).
  - Loosen the nut 6).
  - Loosen the hexagon 5) by a few turns.
  - Lock the nut 6).
  - Reconnect the articulated coupling 4) to the lever 9)(Fig. 27 on page 29).
  - Lift the cam profile 2)(Fig. 27 on page 29) from its initial part by tightening a few screws 1) until the index located on the damper shaft reaches the 0° position again, with the servomotor at 0°.

Once any of the above described calibrations have been performed, start the burner and as soon as the flame is ignited, disconnect the servomotor 10)(Fig. 6 on page 11) by opening the mobile plug-socket 5)(Fig. 7 on page 12) placed on the cable which connects it to the flame control 8)(Fig. 6 on page 11).

**5.6.3 Maximum output**

2nd stage MAX output must be selected within the MAX firing rate range reported in page 9.

**MAX gas delivery adjustment**

Disengage the variable profile cam 2)(Fig. 27 on page 29) from the servomotor by pressing on lever 9)(Fig. 27 on page 29).

Manually rotate the cam 2) slowly clockwise up to 130°, read in correspondence with the index (B) (Fig. 27 on page 29).

Engage the cam 2) to the servomotor again by laterally shifting and then pulling the lever 9)(Fig. 27 on page 29).

At this point, measure the gas delivery.

To reduce it, slightly close the adjustment valve “Gas supply” on page 20 located on the gas train.

To increase it, fully open the adjustment valve and then, if necessary, increase the pressure adjuster outlet gas pressure.

When the pressure adjuster calibration is modified to obtain the required MAX output, the ignition output previously set must be checked again.

The gas delivery must be read on the meter.

A rough indication can be obtained from Tab. H on page 21; just read the gas pressure at the pipe coupling 16)(Fig. 6 on page 11) on the U-shaped pressure gauge (Fig. 21 on page 25) and follow the instructions given on page 21.

**MAX air adjustment**

Adjust the end profile of cam 2)(Fig. 27 on page 29) by turning the screws 1). Do not work on just one screw, but also on those closer to it, so that the cam is progressively curved.

- Tighten the screw to increase the air delivery
- Loosen the screw to reduce the air delivery.

**5.6.4 Minimum output**

The 1st stage minimum output must be selected within the range of MIN values indicated in the diagrams of page 9.

**MIN gas delivery adjustment**

- Disengage the cam by pressing on lever 9)(Fig. 27 on page 29).
- Manually rotate the cam slowly anticlockwise until reaching the 20° position, read in correspondence with the index (B)(Fig. 27 on page 29).
- Engage the cam 2) again by pulling the lever 9)(Fig. 27 on page 29) and measure the gas delivery at the meter.

The MIN delivery can be changed in three ways:

- Turn the disc 2)(Fig. 29) to 0 to reduce the gas delivery, turn it to 2 to increase it.
- Disengage the cam and rotate it by hand anticlockwise until reaching the 10° position to reduce the delivery; rotate it clockwise until reaching the 30° position to increase it.

Then engage the cam II and calibrate the cam III (Fig. 27 on page 29) on the activation point found.

The cam III is factory set to 20° and can be positioned between 10° and 30°.

- Lengthen the tie-rod 4)(Fig. 25 on page 29) of the gas butterfly valve to reduce the delivery, shorten the tie-rod to increase it.

To change the tie-rod length proceed as follows, with the burner off:

- disengage the articulated coupling 1)(Fig. 25 on page 29) from the disc (Fig. 26 on page 29).
- Loosen the nuts 3)(Fig. 25 on page 29).
- Tighten the hexagon 2) to shorten the tie-rod; loosen the hexagon to lengthen it.
- Lock the nut 3).
- Reconnect the articulated coupling 1)(Fig. 25 on page 29) to the disc (Fig. 26 on page 29).

Small changes to the tie-rod for adjusting the min. delivery do not alter the max. delivery which anyway has to be checked.

**MIN air adjustment**

Adjust the initial profile of cam 2)(Fig. 27 on page 29) by gradually turning the screws 1)(Fig. 29).

Pay attention not to change the profile end part that adjusts the damper to the maximum delivery, previously set.

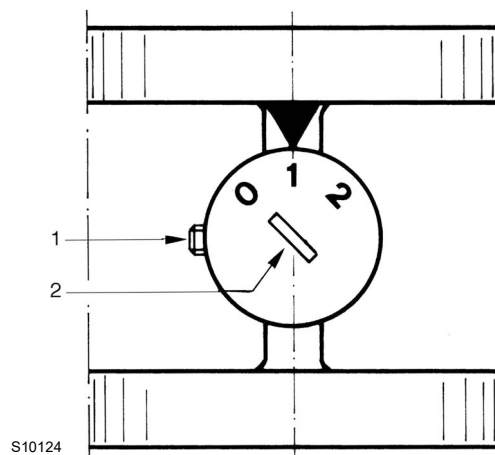

**Fig. 29**

### **5.6.5 Intermediate outputs**

(especially necessary for modulating operation)

#### **Gas**

No adjustment of gas delivery is required.

#### **Air**

The adjustment is carried out by working on the profile cam adjustment intermediate screws 1)(Fig. 27 on page 29), paying attention not to move those related to the minimum and maximum delivery.

Check that the combustion is satisfactory at 2-3 intermediate points between MIN and MAX.

After the adjustment, lock the screws 1)(Fig. 27 on page 29) using the transversal screws 3) and restore the electrical connections of the servomotor by inserting the mobile plug-socket 5)(Fig. 7 on page 12).

**5.7 Pressure switch adjustment**

**5.7.1 Air pressure switch**

Adjust the air pressure switch after performing all other burner adjustments with the air pressure switch set to the start of the scale (Fig. 30).

With the burner operating at MIN output, increase adjustment pressure by slowly turning the relevant knob clockwise until the burner locks out.

Then turn the knob anticlockwise by about 20% of the set point and repeat burner start-up to ensure it is correct. If the burner locks out again, turn the knob slightly anticlockwise.



**WARNING**

As a rule, the air pressure switch must limit the CO in the fumes to less than 1% (10,000 ppm).

To check this, insert a combustion analyser into the chimney, slowly close the fan suction inlet (for example with cardboard) and check that the burner locks out, before the CO in the fumes exceeds 1%.



**WARNING**

Connecting the air pressure switch in differential mode, the burner will no longer be certified according to the EN 676 standard.

**5.7.2 Maximum gas pressure switch**

Adjust the maximum gas pressure switch (Fig. 31) after making all other burner adjustments with the maximum gas pressure switch set to the end of the scale.

To calibrate the maximum gas pressure switch, open the tap and then connect a pressure gauge to its pressure test point.

The maximum gas pressure switch must be regulated to a value no higher than 30% of the measurement read on the gauge when the burner is working at maximum output.

After making the adjustment, remove the pressure gauge and close the tap.

**5.7.3 Minimum gas pressure switch**

The purpose of the minimum gas pressure switch is to prevent the burner from operating in an unsuitable way due to too low gas pressure.

Adjust the minimum gas pressure switch (Fig. 32) after having adjusted the burner, the gas valves and the gas train stabiliser. With the burner operating at maximum output:

- install a pressure gauge downstream of the gas train stabiliser (for example at the gas pressure test point on the burner combustion head);
- choke slowly the manual gas cock until the pressure gauge detects a decrease in the pressure read of about 0.1 kPa (1 mbar). In this phase, verify the CO value which must always be less than 100 mg/kWh (93 ppm).
- Increase the adjustment of the gas pressure switch until it intervenes, causing the burner shutdown;
- remove the pressure gauge and close the cock of the gas pressure test point used for the measurement;
- open completely the manual gas cock.



**WARNING**

1 kPa = 10 mbar

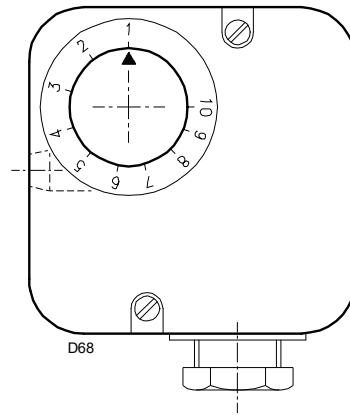

**Fig. 30**

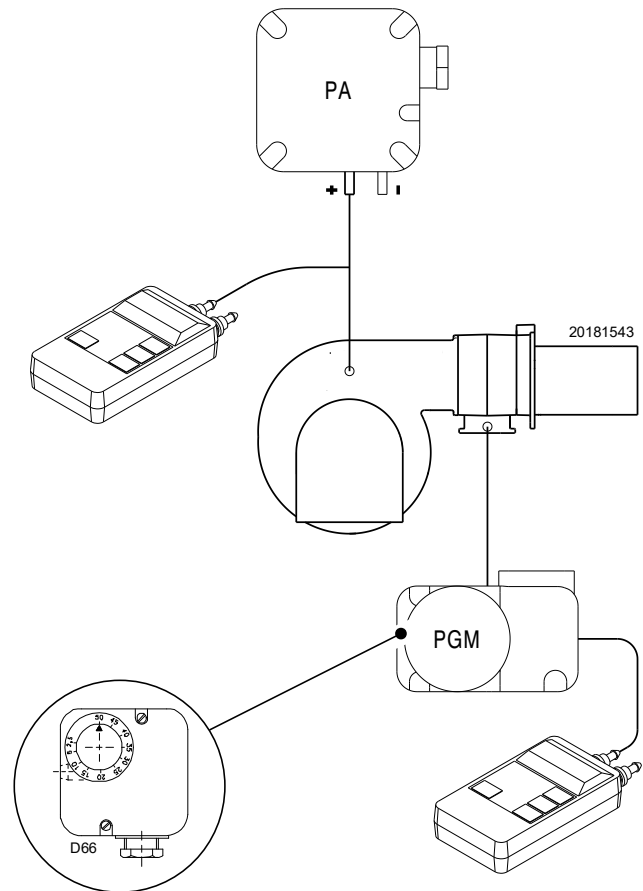

**Fig. 31**

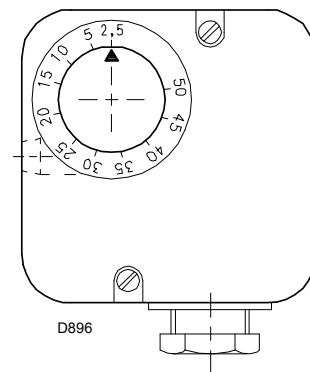

**Fig. 32**

#### 5.7.4 Flame presence check

The burner is fitted with an ionisation system to check that a flame is present. The minimum current for flame control operation is 6  $\mu\text{A}$ .

The burner provides a much higher current, so that no check is usually needed. However, if it is necessary to measure the ionisation current, disconnect the plug-socket 4)(Fig. 7 on page 12) on the ionisation probe cable and insert a full scale 100  $\mu\text{A}$  direct current microammeter.

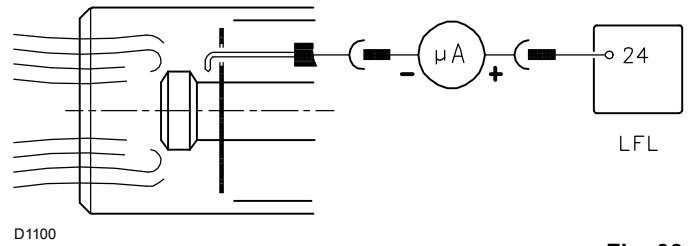

Fig. 33



Carefully check polarities.

**5.8 Burner operation**

**5.8.1 Burner start-up**

(gas trains in compliance with EN 676)

- **0s** : Control remote control TL closes.
- : Servomotor start-up: rotate to the right by 130°, i.e. until the contact intervenes on the cam I (Fig. 24 on page 28).  
**6s** : The air damper is positioned to MAX output.
- **51s** : Pre-purging stage with MAX output air delivery. Duration 31 seconds.
- **82s** : The servomotor rotates to the left until reaching the angle set on cam III (Fig. 24 on page 28) at 20°.
- : The air damper and gas butterfly valve assume the MIN output position - with cam III (Fig. 24 on page 28) at 20°.  
**120s** : The spark goes out.
- **121s** : Ignition electrode strikes a spark.
- : The safety valve VS opens, along with the adjustment valve VR, (quick opening). The flame is ignited at a low output level, point A.  
**127s** : The output is then progressively increased, with the valve opening slowly up to MIN output, point B.
- **130s** : The spark goes out.
- **150s** : The start-up cycle ends

**Burner flame goes out during operation**

If the flame should accidentally go out during operation, the burner will lock out within 1s.

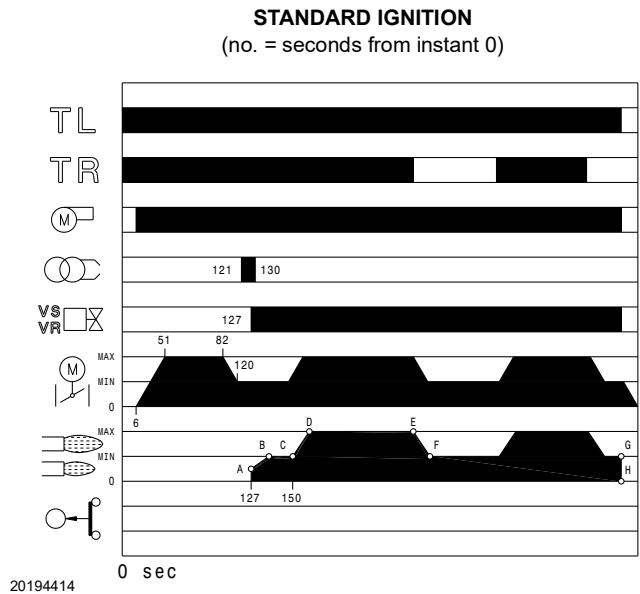

**Fig. 34**

**5.8.2 Steady state operation**

**STEADY STATE OPERATION**

**Burner without output regulator RWF50**

At the end of the start-up cycle, the servomotor control switches to TR remote control that controls the pressure or temperature in the boiler, point C. (The flame control carries on checking the presence of the flame and the correct position of the air and gas maximum pressure switches).

- If the temperature or pressure is low (so the TR remote control is closed), the burner progressively increases the output up to the MAX value (section C-D).
- Then if the temperature or pressure increases until the TR opens, the burner progressively decreases its output to the MIN value (section E-F). And so on.
- The burner locks out when the heat request is less than the heat supplied by the burner at MIN output, (section G-H). The TL remote control opens, and the servomotor returns to angle 0° limited by the contact of cam I (Fig. 27 on page 29). The air damper closes completely to reduce heat losses to a minimum.

Upon every output change, the servomotor will automatically change the gas flow rate (butterfly valve), the airflow (fan damper) and the air pressure (2 shutters in the combustion head).

**Burner with output regulator RWF50**

See the manual supplied with the adjuster.

**5.8.3 Ignition failure**

If the burner does not ignite, it locks out within 3 s after the gas valve opens, 130 seconds from TL closure.

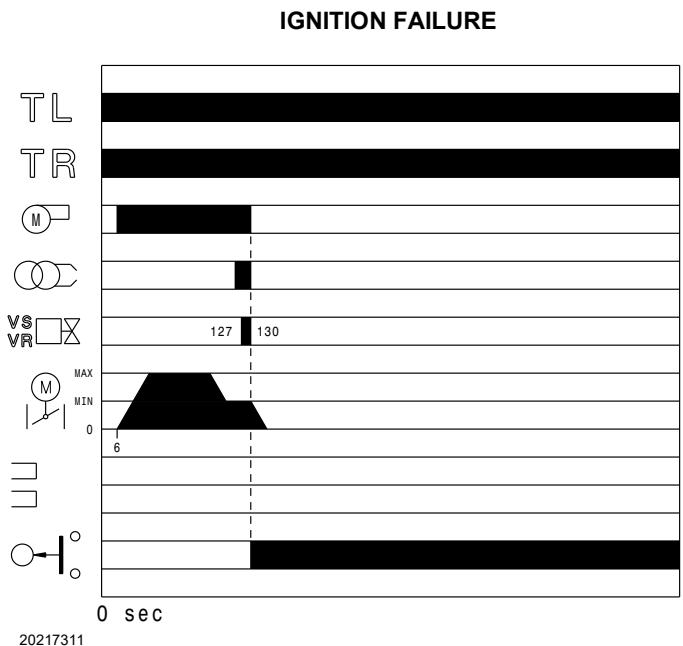

**Fig. 35**

## 6 Maintenance

### 6.1 Notes on safety for the maintenance

The periodic maintenance is essential for the good operation, safety, yield and duration of the burner.

It allows you to reduce consumption and polluting emissions and to keep the product in a reliable state over time.



The maintenance interventions and the calibration of the burner must only be carried out by qualified, authorised personnel, in accordance with the contents of this manual and in compliance with the standards and regulations of current laws.

Before carrying out any maintenance, cleaning or checking operations:



Disconnect the electrical supply from the burner by means of the system main switch.



Close the fuel shut-off valve.



Wait for the components in contact with heat sources to cool down completely.

### 6.2 Maintenance programme

#### 6.2.1 Maintenance frequency



The gas combustion system should be checked at least once a year by a representative of the manufacturer or another specialised technician.

#### 6.2.2 Safety test - with no gas supply

To perform commissioning in safety conditions, it is very important to check correct wiring between gas valves and burner.

For this purpose, after checking that connections comply with the burner wiring diagrams, it is necessary to carry out a start-up cycle with gas cock closed (dry test).

- 1 The manual gas valve must be closed using the locking/unlocking device ("Lock-out / tag out" procedure).
- 2 Ensure that burner limit electrical contacts are closed
- 3 Ensure that minimum gas pressure switch contact is closed
- 4 Try to start the burner.

The start-up cycle must occur according to the following steps:

- Fan motor start-up for pre-purging
- Gas valve leak detection control, if applicable.
- Pre-purging completion
- Achievement of the ignition point
- Power supply of the ignition transformer
- Supply of gas valves.

As gas is closed, the burner cannot ignite and its flame control will switch to stop or safety lockout condition.

The actual supply of gas valves can be checked by inserting a tester; some valves are equipped with lights (or closing/opening position indicators) that activate as soon as they are powered.



**IF POWER SUPPLY OF GAS VALVES OCCURS IN UNEXPECTED MOMENTS, DO NOT OPEN THE MANUAL VALVE, DISCONNECT POWER SUPPLY, CHECK WIRINGS, CORRECT THE ERRORS AND CARRY OUT THE WHOLE TEST AGAIN.**

#### 6.2.3 Checking and cleaning



The operator must use the required equipment during maintenance.

##### Burner

Check that there are not excess wear or loosen screws. The screws securing the electrical leads in the burner plugs should also be fully tightened.

Clean the outside of the burner.

Clean and grease the adjustable profile of the cams.

##### Fan

Check to make sure that no dust has accumulated inside the fan or on its impellers, as this condition will cause a reduction in the air flow rate and provoke polluting combustion.

##### Boiler

Clean the boiler as indicated in its accompanying instructions in order to maintain all the original combustion characteristics intact, especially: the flue gas temperature and combustion chamber pressure.

##### Gas leaks

Make sure that there are no gas leaks on the pipe between the gas meter and the burner.

##### Gas filter

Change the gas filter when it is dirty.

### Combustion

Carry out an analysis of the combustion flue gases. Significant differences with respect to the previous measurements indicate the points where most care should be exercised during maintenance.

If the combustion values measured before starting maintenance do not comply with applicable Standards or do not indicate efficient combustion, consult the table below or contact our Technical Support Service to implement the necessary adjustments.

EN 676		Air excess		CO
		Max. output $\lambda \leq 1.2$	Max. output $\lambda \leq 1.3$	
GAS	Theoretical max CO <sub>2</sub> 0% O <sub>2</sub>	CO <sub>2</sub> % Calibration		mg/kWh
		$\lambda = 1.2$	$\lambda = 1.3$	
G 20	11.7	9.7	9	≤ 100
G 25	11.5	9.5	8.8	≤ 100

Tab. I

### 6.2.4 Combustion control (gas)

#### CO<sub>2</sub>

It is advisable to adjust the burner with a CO<sub>2</sub> not greater than about 10% (gas with Ncv 8600 kcal/m<sup>3</sup>). In this way it is avoided that a small decalibration (for example a variation in the tension) could cause a combustion with an air defect and with the subsequent formation of CO.

#### CO

It should not exceed 100 mg/kWh.

### 6.2.5 Safety components

The safety components should be replaced at the end of their life cycle indicated in the following table.



WARNING

The specified life cycles do not refer to the warranty terms indicated in the delivery or payment conditions.

Safety component	Life cycle
Flame control	10 years or 250.000 operation cycles
Flame sensor	10 years or 250.000 operation cycles
Gas valves (solenoid)	10 years or 250.000 operation cycles
Pressure switches	10 years or 250.000 operation cycles
Pressure adjuster	15 years
Servomotor (electronic cam)(if any)	10 years or 250.000 operation cycles
Oil valve (solenoid) (if any)	10 years or 250.000 operation cycles
Oil regulator (if present)	10 years or 250.000 operation cycles
Oil pipes/ couplings (metallic) (if present)	10 years
Fan impeller	10 years or 500.000 start-ups

Tab. J

**6.3 Opening the burner**



Disconnect the electrical supply from the burner by means of the system main switch.



Wait for the components in contact with heat sources to cool down completely.



Close the fuel shut-off valve.

- Remove the screws 7)(Fig. 36) retaining the fan 3) to the coupling 4).
- Open the burner by moving the unit fan backwards on the two slide bars 6). The unit coupling remains fitted to the boiler.

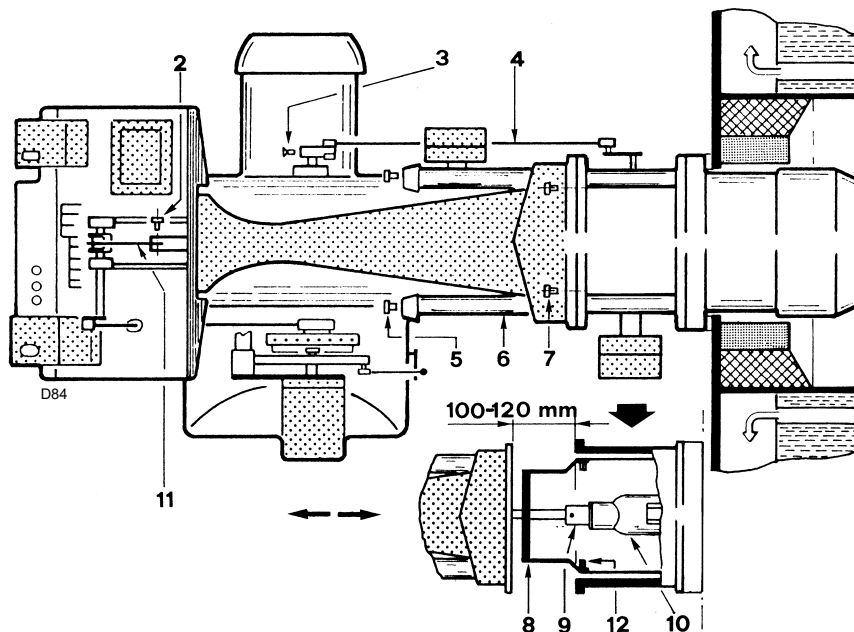

Fig. 36

**6.4 Closing the burner**



When fitting the burner on the two slide bars, it is advisable to gently draw out the high voltage cable and the flame detection probe cable until they are slightly stretched.



After carrying out maintenance, cleaning or checking operations, reassemble the cover and all the safety and protection devices of the burner.

**7 Faults - Possible causes - Solutions**

The LFL... flame control is equipped with a lockout indicator (Fig. 37) that turns during the start-up programme, and is visible from the small lockout window.

When the burner does not start or stops, due to a failure, the symbol that appears on the indicator indicates the type of interruption. The positions of the lockout indicator are shown in Fig. 38.

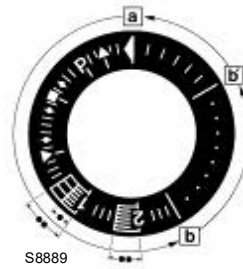

**Lockout indicator**

- a-b Start-up sequence
- b(b') Idle stages (without contact confirmation)
- b(b')-a Post-purging programme

**Fig. 37**

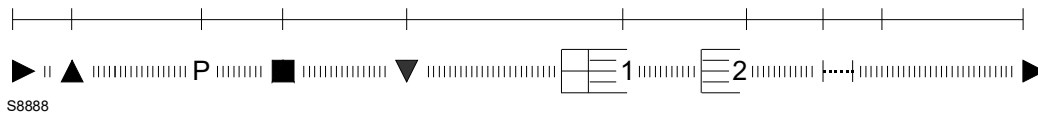

**Fig. 38**

**Fuse replacement**

The fuse 2)(Fig. 39) is in the rear part of the flame control. A spare fuse 1) is also available: it can be extracted after breaking the panel tab A) that houses it. In the event that fuse 2) has been tripped, replace it as shown in Fig. 39.

Find a list of faults, causes and possible solutions for a set of failures that may occur and result in irregular burner operation or no functioning at all.

If a burner malfunction is detected, first of all:

- check that the electrical wiring is adequately connected;
- check whether fuel is delivered;
- check that every adjustment parameter is adequately set.



**WARNING**

In the event the burner stops, in order to prevent any damage to the installation, do not unblock the burner more than twice in a row. If the burner locks out for a third time, contact the customer service.



**DANGER**

In the event there are further lockouts or faults with the burner, the maintenance interventions must only be carried out by qualified, authorised personnel, in accordance with the contents of this manual and in compliance with the standards and regulations of current laws.

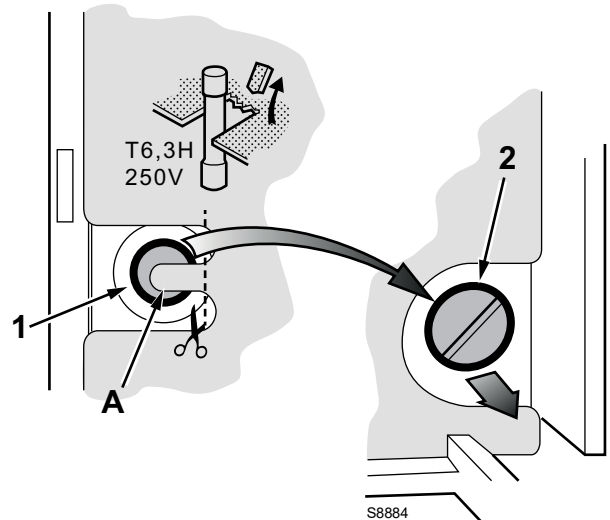

**Fig. 39**

7.1 Gas operation

Symbol	Problem	Probable cause	Suggested remedy
◀	The burner does not start	No electrical power supply	Close all switches and check connections
		A limit or safety thermostat/pressure switch open	Adjust or replace
		Flame control lockout	Release the flame control
		Flame control fuse interrupted	Replace it (2)
		Incorrect electrical wiring	Check
		Defective flame control	Replace
		No gas supply	Open the manual valves between meter and train
		Mains gas pressure insufficient	Contact your GAS COMPANY
		Minimum gas pressure switch fails to close	Adjust or replace
		Air pressure switch in operating position	Adjust or replace
		The servomotor contact does not intervene (closure cam 0°)	Adjust the closure cam 0° or replace the servomotor
	The burner does not come on and the lockout appears	Flame simulation	Replace the flame control
		Faulty motor remote control switch	Replace
		Defective electrical motor	Replace
▲	The burner starts but stops at maximum air damper setting	Motor lockout	Release the thermal relay
		The servomotor contact does not intervene (maximum cam opening)	Cam adjustment (maximum opening) or replace the servomotor
P	The burner starts and then goes into lockout	Air pressure switch does not switch owing to lack of air pressure:	
		Air pressure switch poorly adjusted	Adjust or replace
		Pressure switch pressure point pipe clogged	Clean
		Poorly adjusted head	Adjust
		Dirty fan	Clean
		High depression in the furnace	Contact our Technical Department
■	The burner turns on and then remains in lockout mode	Failure to the flame detection circuit	Replace the flame control
▼	The burner remains in pre-purging phase	The servomotor contact does not intervene (minimum cam)	Cam adjustment (minimum) or replace the servomotor

Symbol	Problem	Probable cause	Suggested remedy
1	Once the pre-purging and the safety time has elapsed the burner goes into lockout without the flame appearing	The GAS solenoid valve lets too little gas through	Increase
		The GAS solenoid valve does not open	Replace the coil or the rectifier panel
		Gas pressure too low	Increase pressure at governor
		Ignition electrode incorrectly adjusted	Adjust it
		Electrode grounded due to broken insulation	Replace
		High voltage cable defective or grounded	Replace
		High voltage cable deformed by high temperature	Replace and protect
		Faulty ignition transformer	Replace
		Incorrect valve or ignition transformer connections	Redo them
		Defective flame control	Replace
		A closed valve upstream the gas train	Open
	Air in pipework	Bleed air	
	Lockout with flame appearing	The GAS solenoid valve lets too little gas through	Increase
		Dirty flame sensor	Check, replace flame sensor
		Faulty connection	Check, replace flame sensor
Insufficient detection current (min.70 $\mu$ A)		Measure current, replace flame sensor	
Flame sensor exhausted, faulty		Replace	
Maximum gas pressure switch intervention		Adjust or replace	
Defective flame control	Replace		
	The burner continues to repeat the start-up cycle without lockout	The gas pressure in the gas mains lies very close to the value to which the gas pressure switch has been set. The sudden drop in pressure after valve opening causes temporary opening of the pressure switch itself, the valve immediately closes and the burner stops. Pressure increases again, the pressure switch closes again and the ignition cycle is repeated. And so on.	Reduce the intervention pressure of the minimum gas pressure switch. Replace the gas filter cartridge
	Lockout without symbol indication	Flame simulation	Replace the flame control
	Burner goes into lockout during operation	Faulty flame sensor	Replace worn parts
		Air pressure switch faulty	Replace
◀	Lockout when the burner stops	Permanent flame in the combustion head or flame simulation	Eliminate permanency of flame or replace the flame control
	Ignition with pulsations	Poorly adjusted head	Adjust
		Ignition electrode incorrectly adjusted	Adjust it
		Incorrectly adjusted fan air damper: too much air	Adjust
		Output during ignition phase is too high	Reduce

Tab. K

## A Appendix - Accessories

### Spacer kit to shorten the combustion head

L = Spacer thickness

L1 = Resulting blast tube length

Burner	mm	mm	Code
GAS 8 P/M	L = 110	L1 = 281	3000722
GAS 9 P/M	L = 130	L1 = 314	3000723
GAS 10 P/M	L = 130	L1 = 346	3000751

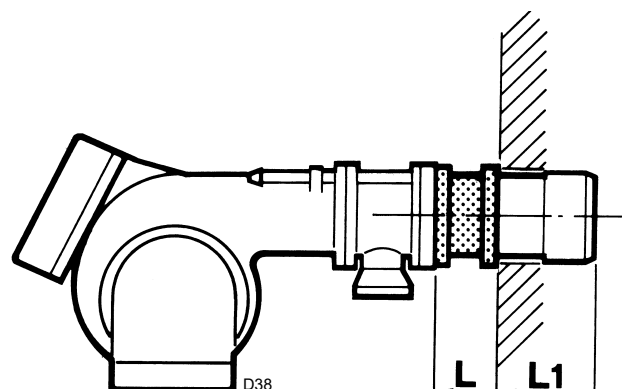

### Output regulator kit for modulating operation

With modulating operation, the burner continuously adjusts its output to the heat request, thereby ensuring a great stability of the controlled parameter: temperature or pressure.

The parts to be ordered are two:

- output regulator to be installed to the burner;
- probe to be installed to the heat generator

Parameter to be controlled		Probe		Regulator	
	Firing rate	Type	Code	Type	Code
Temperature	- 100...+ 500 °C	PT 100	3010110	RWF50	20100018
Pressure	0...2.5 bar	Output probe	3010213	RWF55	20101965
	0...16 bar	4...20 mA	3010214		

### Support

It has to be fitted to burners with extended head (501-574-606). It ensures the burner safety when it is opened on the elongated slide bars.

The support is not essential for burners with short head, but it makes it easier to open them.

The 1" 1/2 tube of the support has to be adjusted by the installer to the length suitable for the system.

The base is equipped with wheels.

Burner	Code
All models	3000731

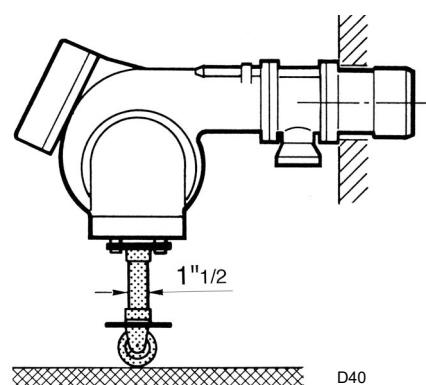

### Thermal relay 230V kit

Burner	Code
GAS 9 P/M	20163347

### Potentiometer kit

It consists of a three-pole potentiometer with a value of 0-1000 % for 0-100% stroke, to be installed inside the servomotor 10)(Fig. 6 on page 12).

It signals the servomotor position to provide indications or feedbacks to different kinds of tools.

Burner	Code
All models	20096322

**Continuous purging kit**

---

It is made of a small three-way solenoid valve to be installed between the air pressure switch and the fan. It allows the burner to ignite again after the continuous ventilation following flame extinction.

Burner	Code
All models	3010030

**Town gas kit**

---

Burner	Code
GAS 9 P/M	3010298
GAS 10 P/M	3010300

**Soundproofing box kit**

---

Burner	Code
GAS 8 P/M	3010404
GAS 9-10 P/M	3010376

**Gas trains in compliance with EN 676**

---

Please refer to manual.



**ATTENTION**

The installer is responsible for the addition of any safety device not foreseen in this manual.

**B Appendix - Electrical panel layout**

<b>1</b>	<b>Index of layouts</b>
<b>2</b>	Indication of references
<b>3</b>	Functional diagram (Direct start-up) GAS 8 P/M Functional diagram (Direct start-up) GAS 9 P/M Functional diagram (Star-Triangle start-up) GAS 9 P/M Functional diagram (Star-Triangle start-up) GAS 10 P/M
<b>4</b>	Functional diagram (Direct start-up) Functional diagram (Star-Triangle start-up)
<b>5</b>	Electrical connections to be carried out by the installer (Direct start-up) GAS 8 P/M Electrical connections to be carried out by the installer (Direct start-up) GAS 9 P/M Electrical connections to be carried out by the installer (Star-Triangle start-up)
<b>6</b>	RWF Functional diagram (Direct start-up) Electrical connections to be carried out by the installer (Star-Triangle start-up) GAS 9 P/M Electrical connections to be carried out by the installer (Star-Triangle start-up) GAS 10 P/M
<b>7</b>	RWF Functional diagram (Star-Triangle start-up)

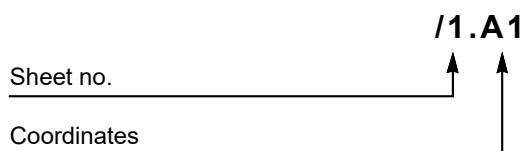
**2 Indication of references**

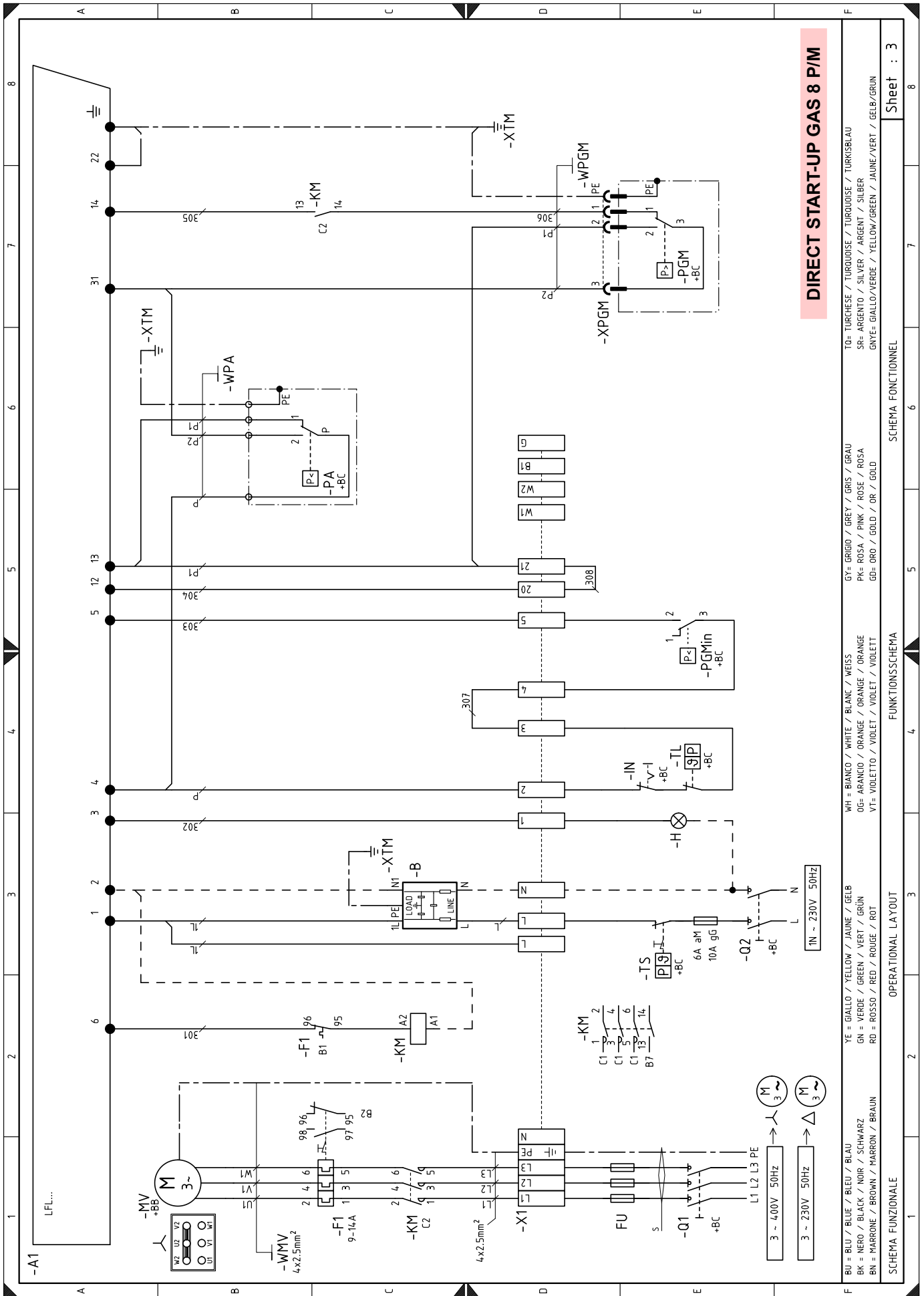



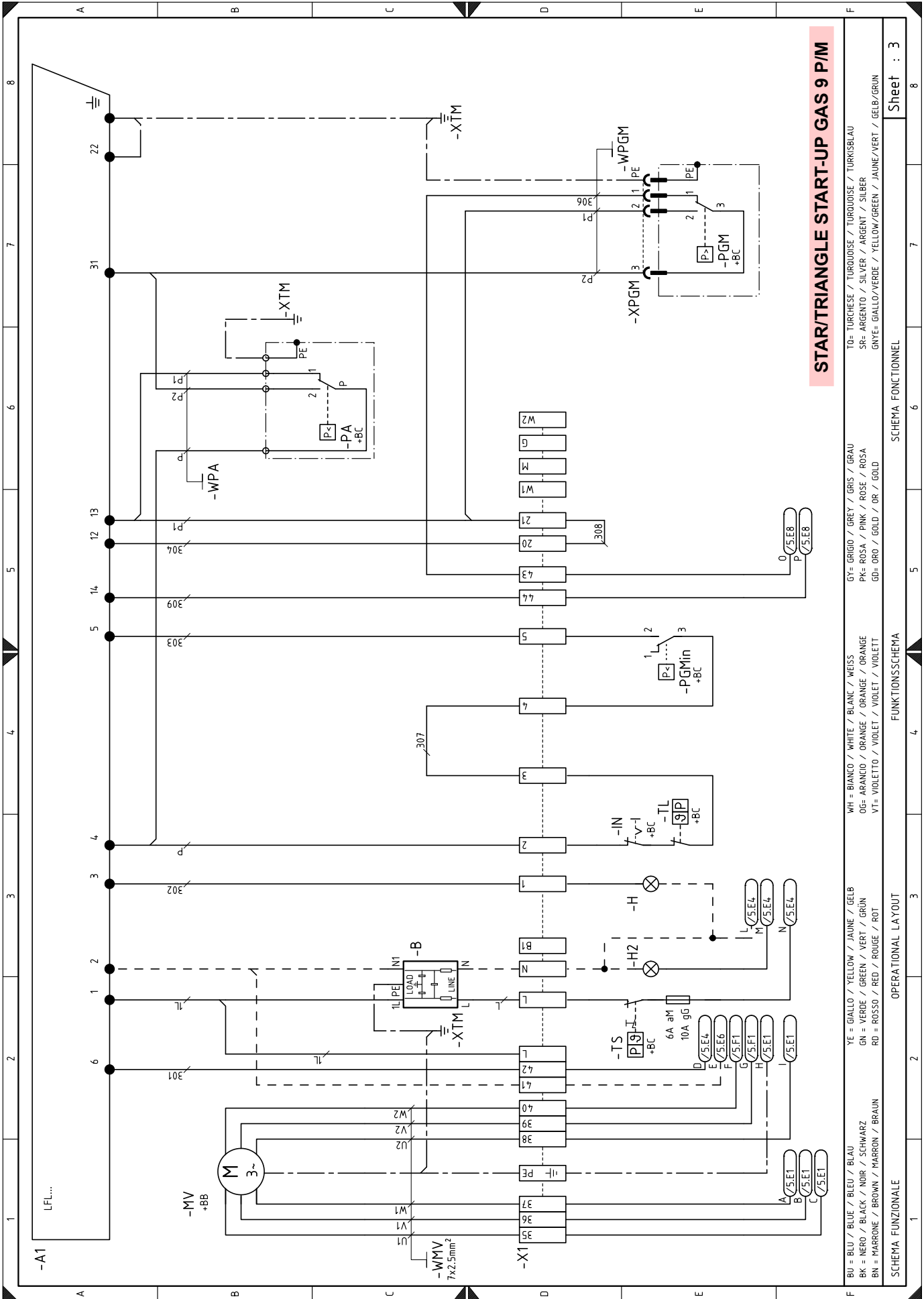

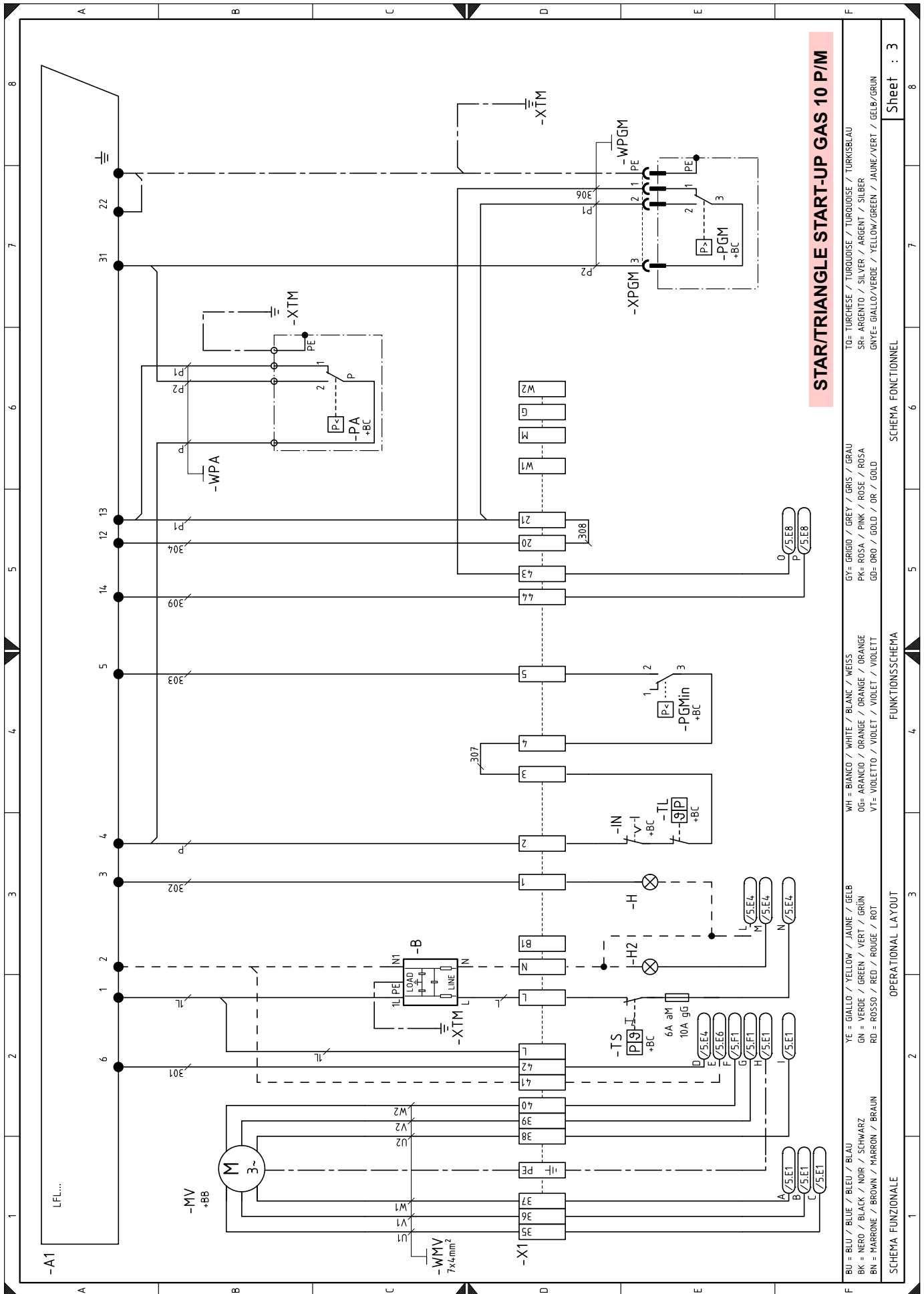

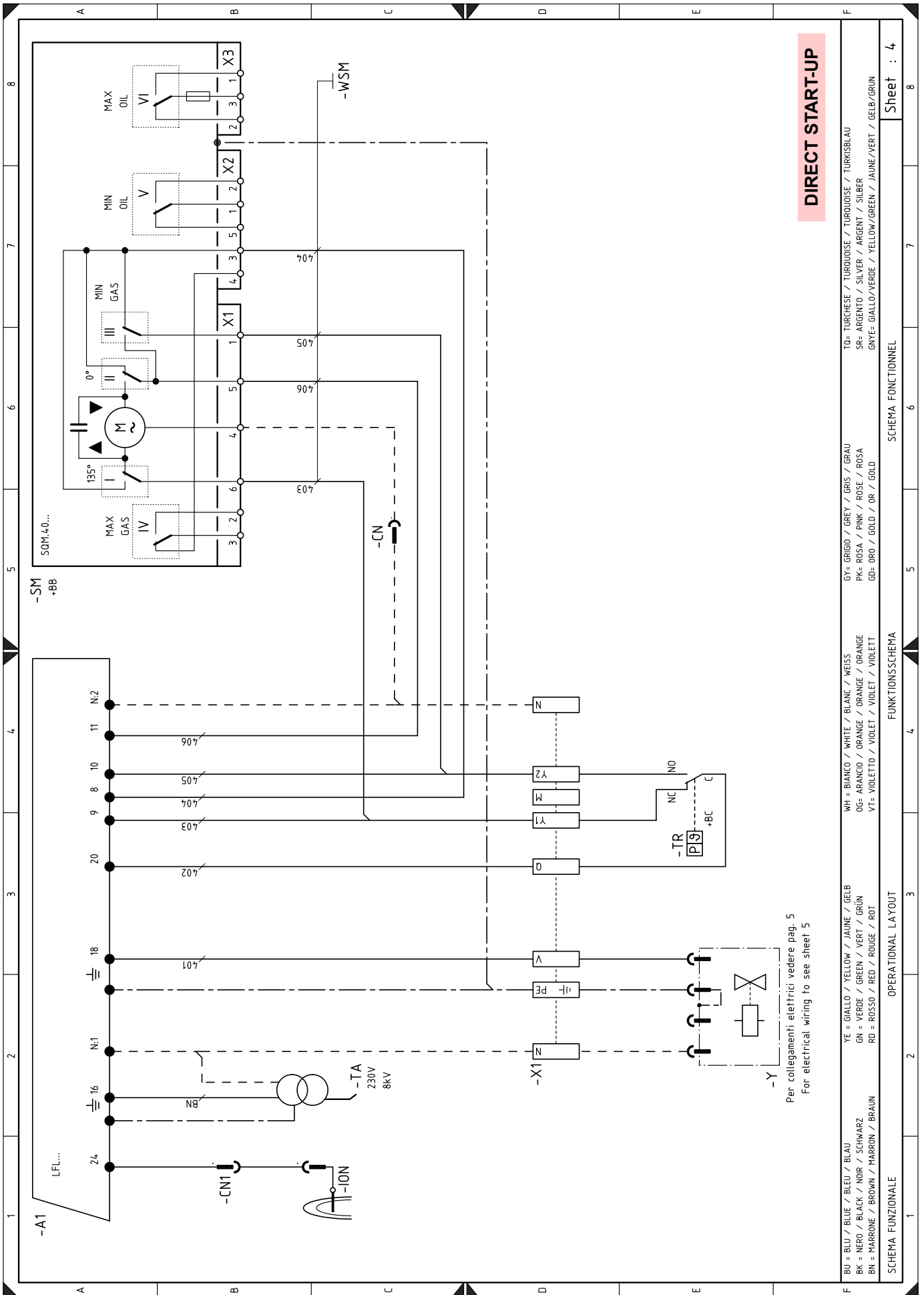

- BU = BLU / BLEU / BLAU
- BK = NERO / BLACK / NOIR / SCHWARZ
- BN = MARRONE / BROWN / MARRON / BRAUN
- YE = GIALLO / YELLOW / JAUNE / GÉLB
- GN = VERDE / GREEN / VERT / GRÜN
- RD = ROSSO / RED / ROUGE / ROT
- WH = BIANCO / WHITE / BLANC / WEISS
- OG= ARANCIO / ORANGE / ORANGE / ORANGE
- V7= VIOLETTO / VIOLET / VIOLET / VIOLETT
- GY= GRIGIO / GREY / GRIS / GRAU
- PK= ROSA / PINK / ROSE / ROSA
- GD= ORO / GOLD / OR / GOLD
- TO= TURCHESE / TURQUOISE / TURKOISE / TURKISBLAU
- SR= ARGENTO / SILVER / ARGENT / SILBER
- GNYE= GIALLO/VERDE / YELLOW/GREEN / JAUNE/VERT / GELB/GRÜN

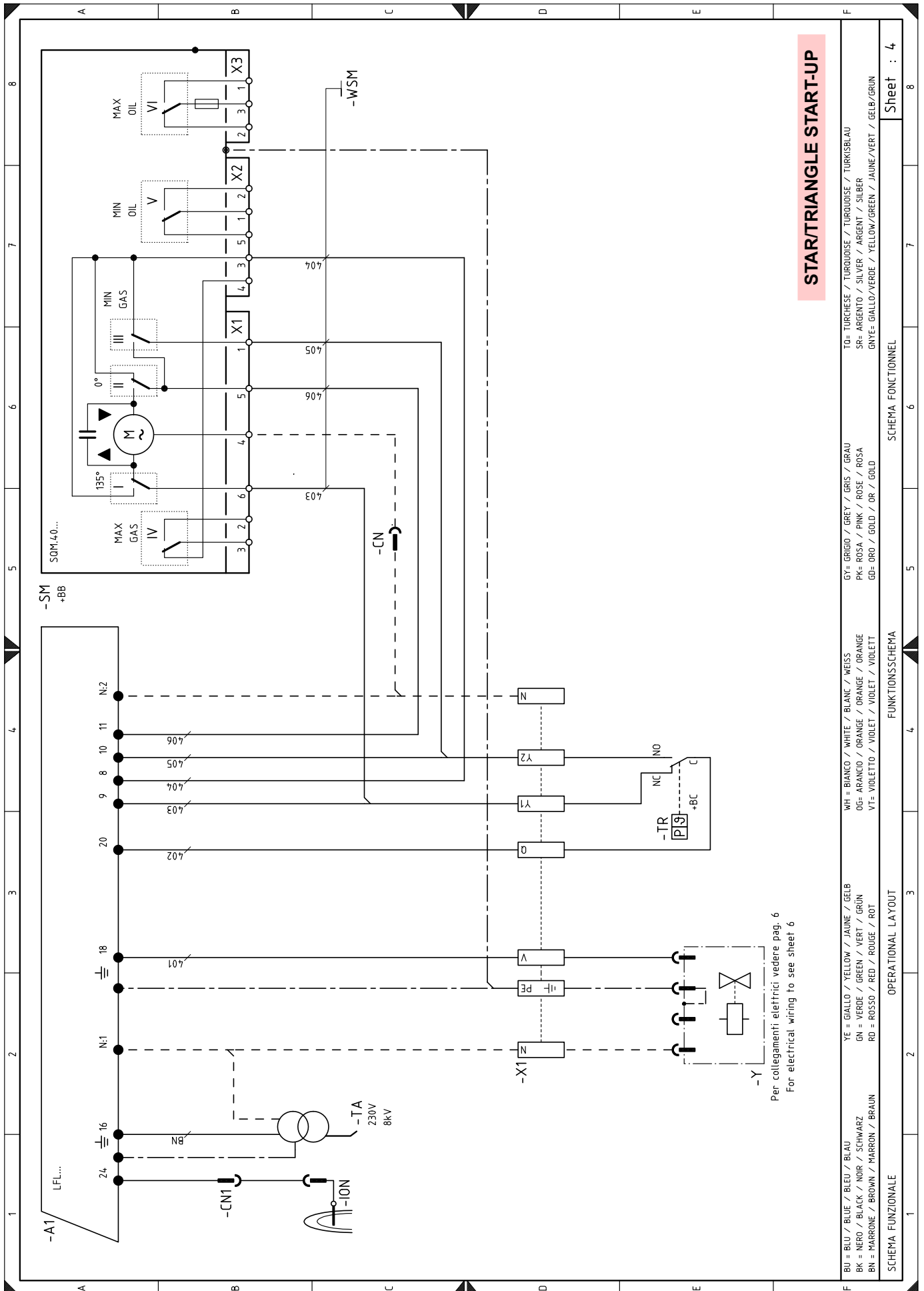

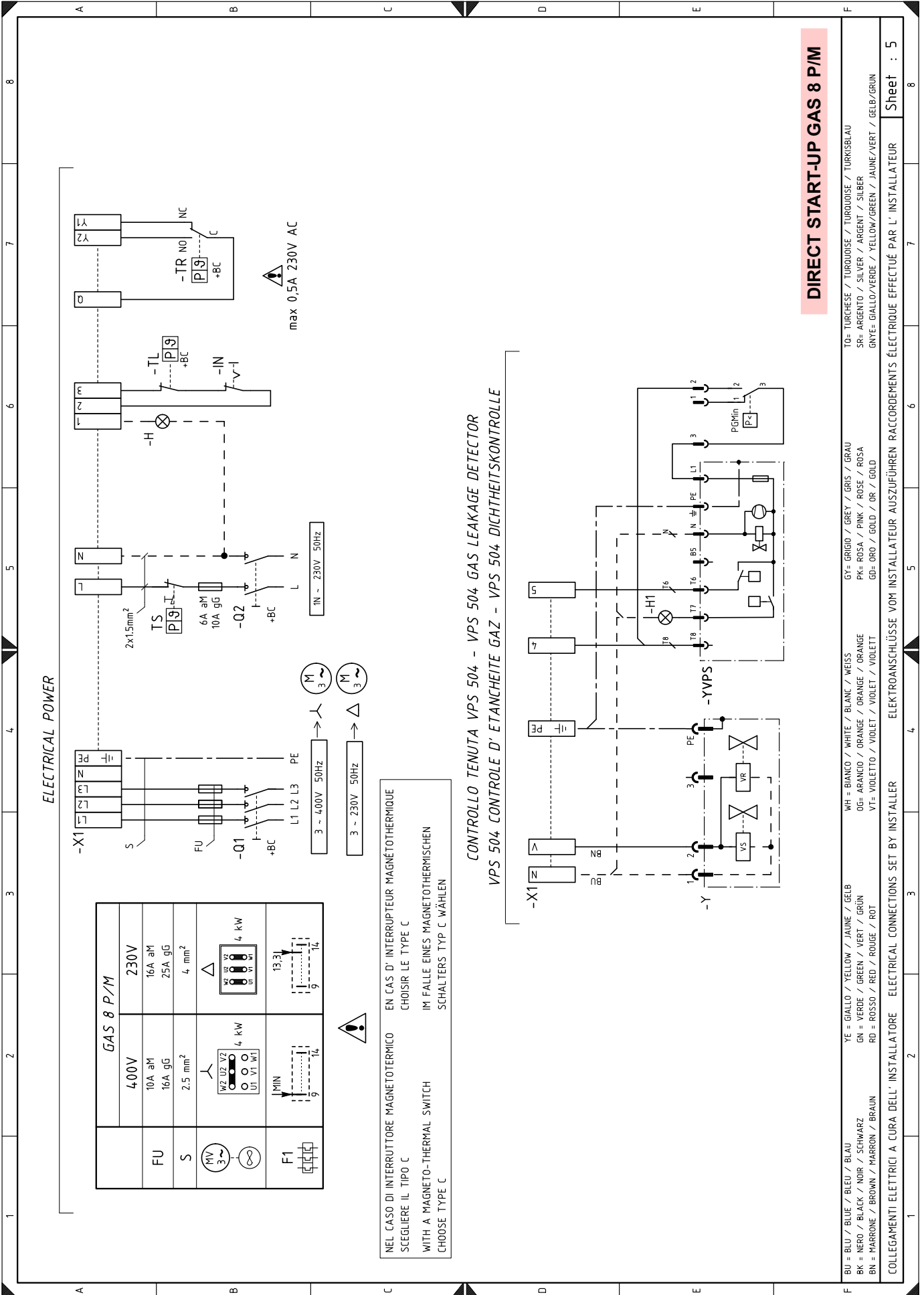

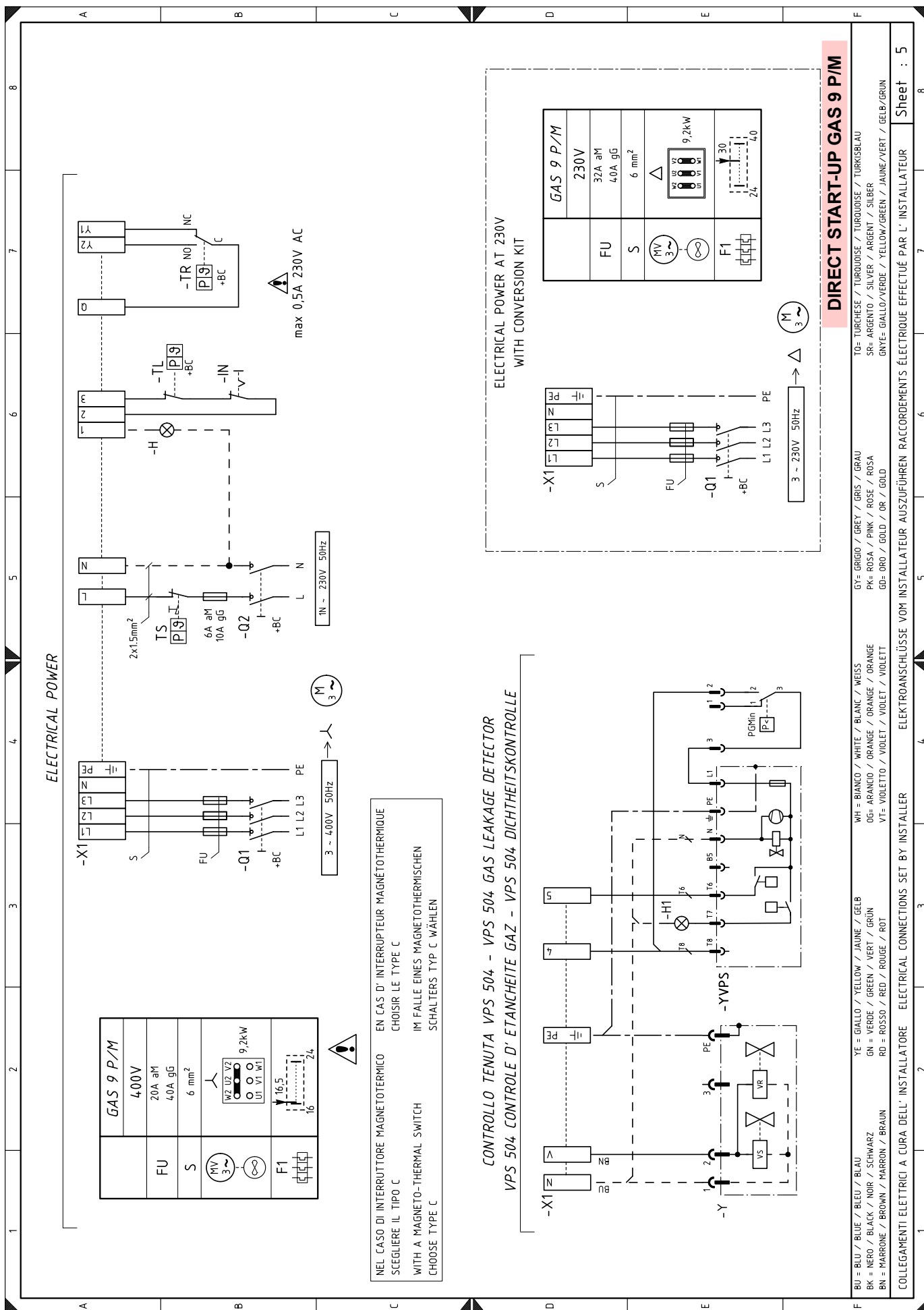

**CONTROLLO TENUTA VPS 504 - VPS 504 GAS LEAKAGE DETECTOR**  
**VPS 504 CONTROLE D' ETANCHEITE GAZ - VPS 504 DICHTHEITSKONTROLLE**

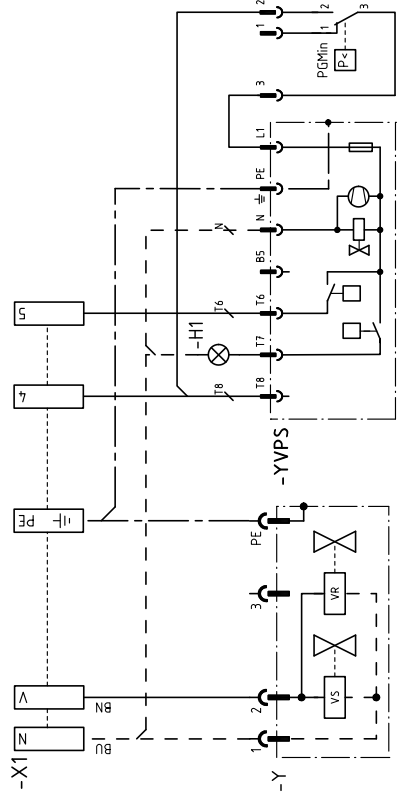

**ELECTRICAL POWER AT 230V WITH CONVERSION KIT**

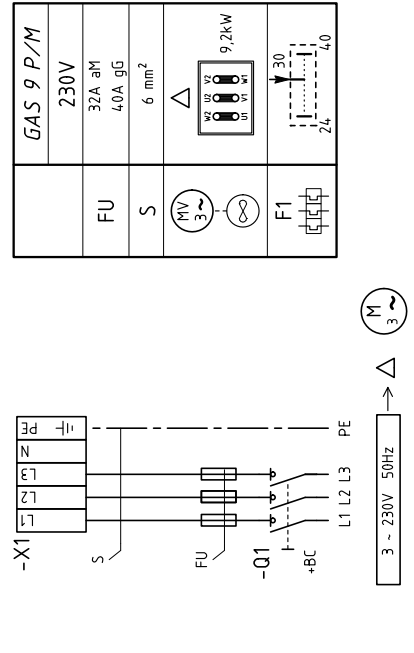

**DIRECT START-UP GAS 9 P/M**

- COLLEGAMENTI ELETTRICI A CURA DELL' INSTALLATORE ELECTRICAL CONNECTIONS SET BY INSTALLER
- YE = GIALLO / YELLOW / JAUNE / GELB  
 GN = VERDE / GREEN / VERT / GRÜN  
 BK = NERO / BLACK / NOIR / SCHWARZ  
 BN = MARRONE / BROWN / MARRON / BRAUN  
 WH = BIANCO / WHITE / BLANC / WEISS  
 OG= ARANCIO / ORANGE / ORANGE / ORANGE  
 VT= VIOLETTO / VIOLET / VIOLET / VIOLETT  
 GR= GRIGIO / GREY / GRIS / GRAU  
 PK= ROSA / PINK / ROSE / ROSA  
 GD= ORO / GOLD / OR / GOLD  
 TO= TURCHESE / TURQUOISE / TURQUOISE / TURKISBLAU  
 SR= ARGENTO / SILVER / ARGENT / SILBER  
 GNYE= GIALLO/VERDE / YELLOW/GREEN / JAUNE/VERT / GELB/GRÜN
- Sheet : 5

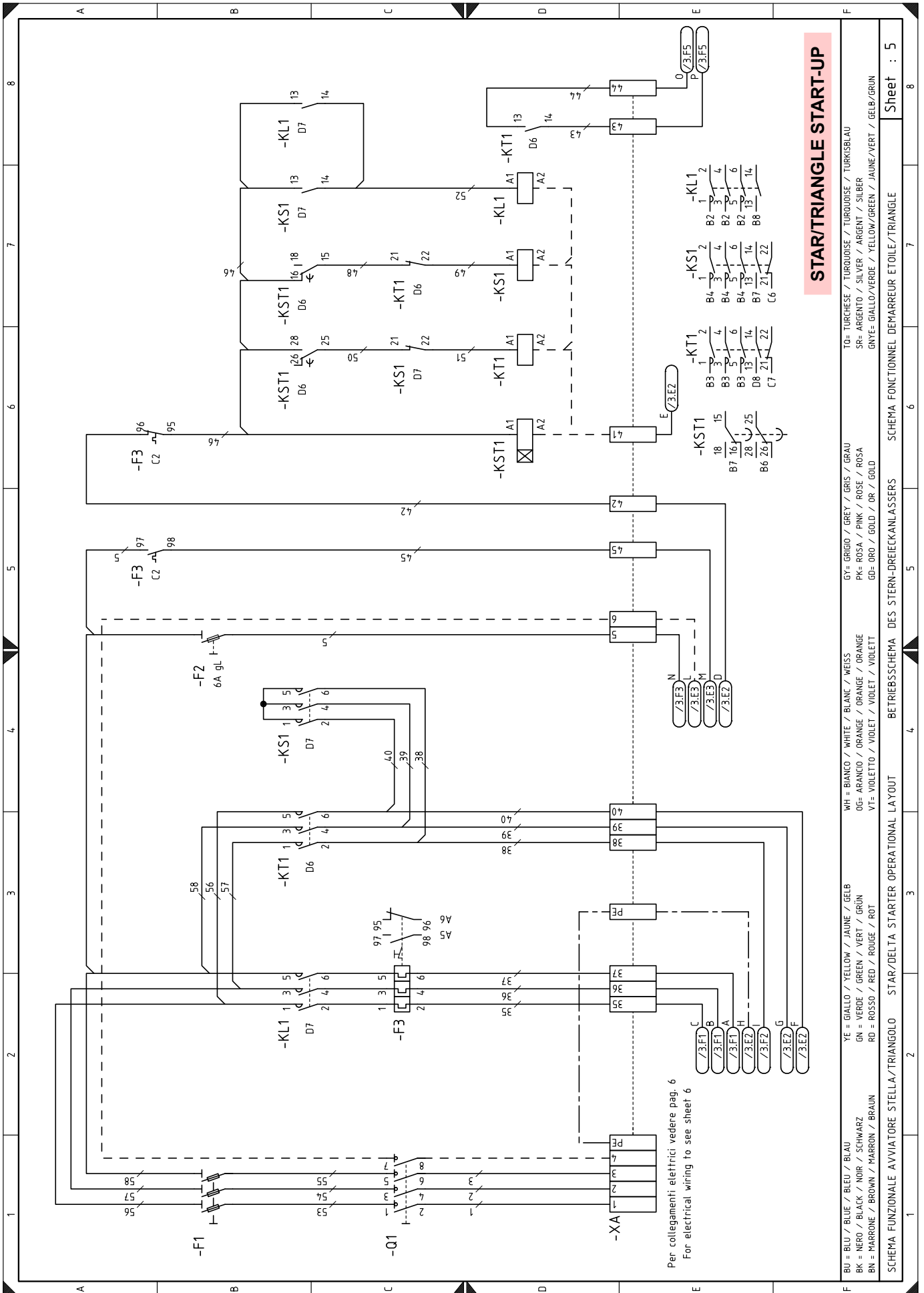



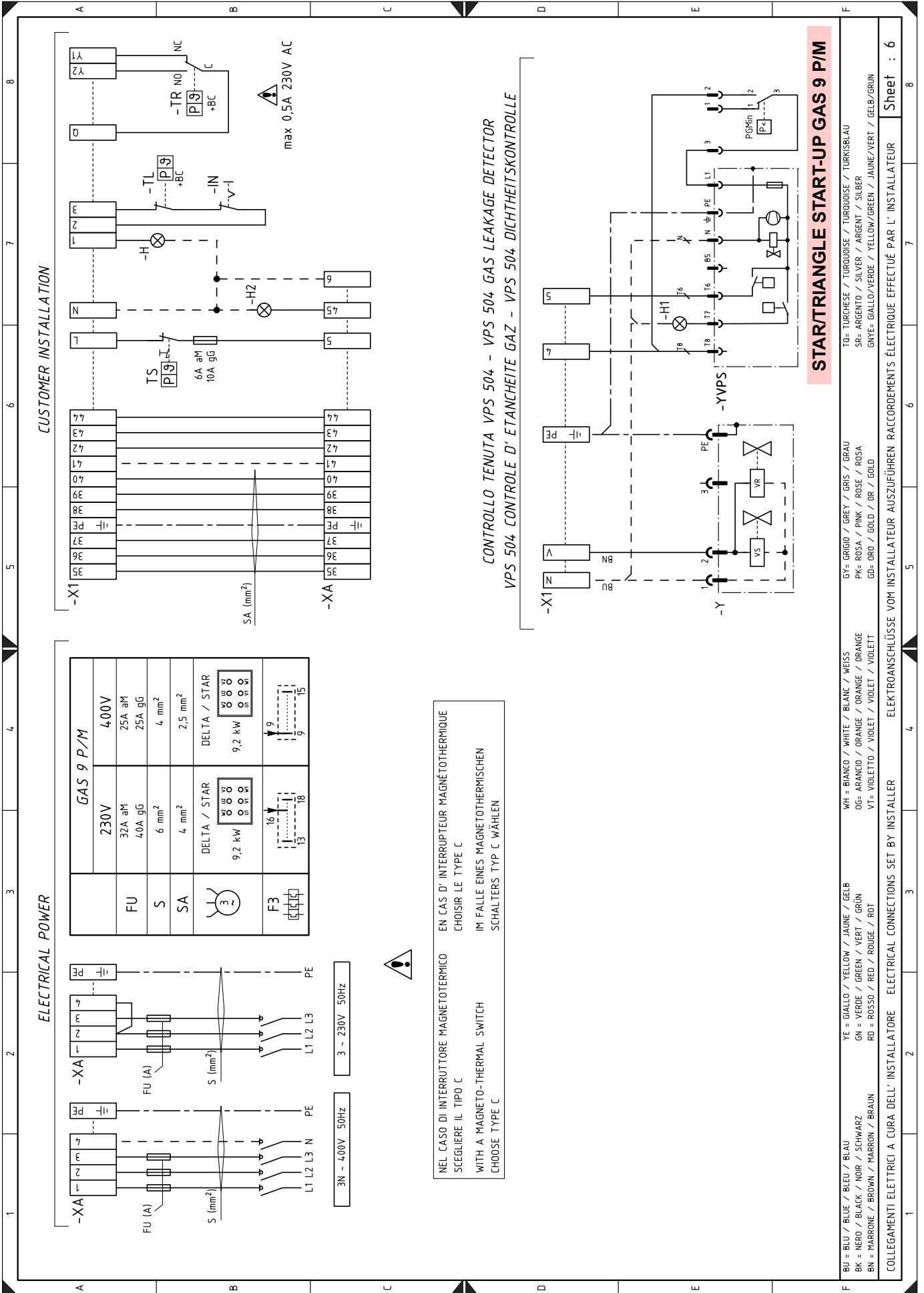

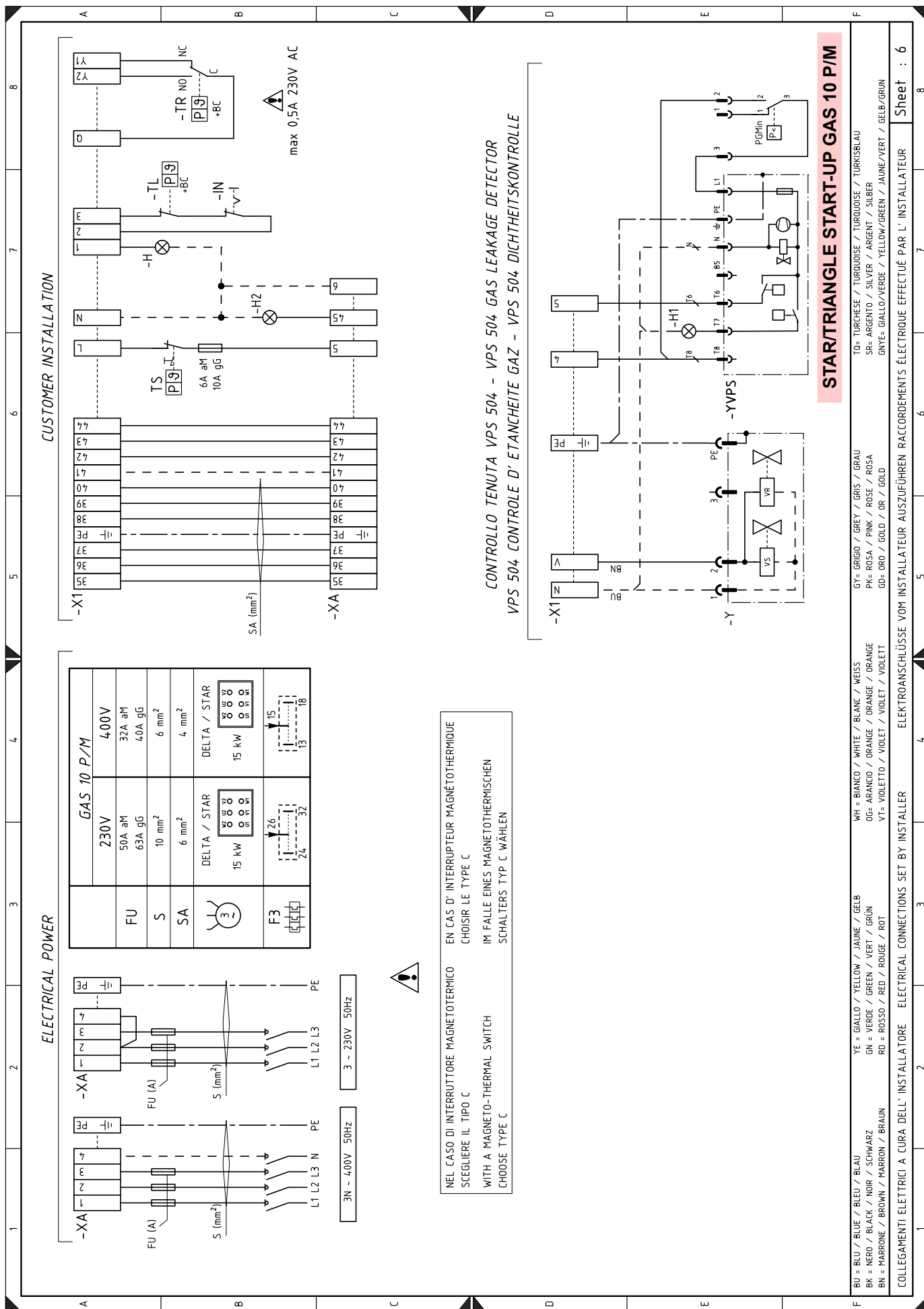

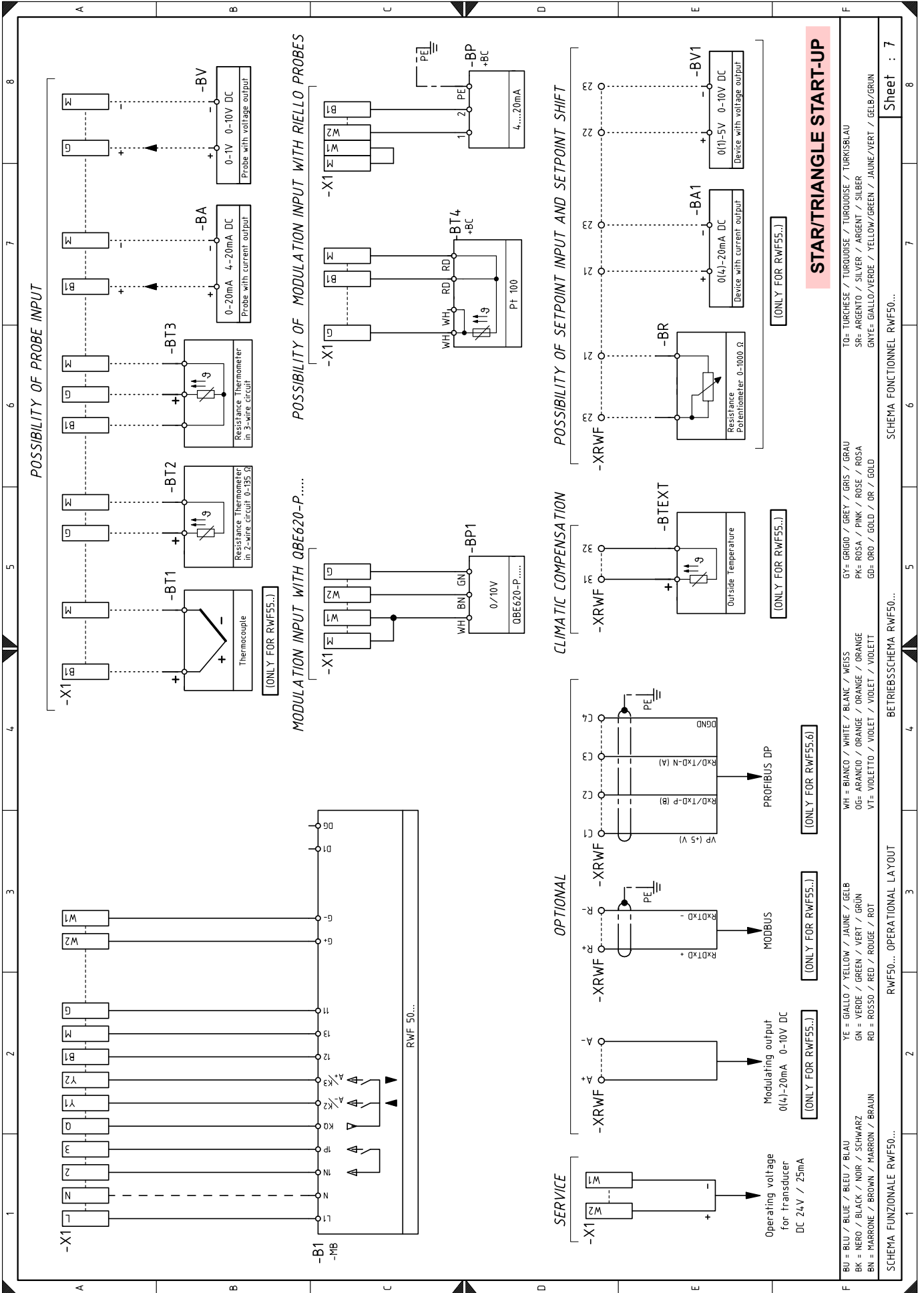

**WIRING DIAGRAM KEY**

A1	Flame control
B	Filter to protect against radio disturbance
B1	RWF50 output power regulator
BA	Current input DC 4...20mA
BA1	Current input DC 4...20mA for remote setpoint modification
BP	Pressure probe
BP1	Pressure probe
BR	Remote setpoint potentiometer
BT1	Thermocouple probe
BT2	Probe Pt100, 2 wires
BT3	Probe Pt100, 3 wires
BT4	Probe Pt100, 3 wires
BTEXT	External probe for climatic compensation of the setpoint
BV	Voltage input DC 0...10V
BV1	Voltage input DC 0...10V for remote setpoint modification
CN	Servomotor connector
CN1	Ionisation probe connector
FU	Three-phase line fuses
F1	Thermal relay, Three-phase line fuses
F2	Single-phase line fuses
F3	Thermal relay
H	Remote lockout signal
H1	Remote lockout signal due to leak detection control
H2	Remote motor lockout signal
IN	Burner manual stop switch
ION	Ionisation probe
KL1	Line contactor
KM	Motor contactor
KS1	Star contactor
KST1	Timing relay for switching from star to triangle
KT1	Triangle contactor
MV	Fan motor
PA	Air pressure switch
PGM	Maximum gas pressure switch
PGMin	Minimum gas pressure switch
Q1	Three-phase disconnecting switch
Q2	Single-phase disconnecting switch
SM	Servomotor
TA	Ignition transformer
TL	Limit thermostat/pressure switch
TR	Adjustment thermostat/pressure switch
TS	Safety thermostat/pressure switch
X1	Burner terminal strip
XA	Starter terminal strip
XPE	Earth flame control
XPGM	Maximum gas pressure switch connector
XRWF	RWF50 terminal board
Y	Gas adjustment valve + gas safety valve
YVPS	Leak test

---

**RIELLO**

RIELLO S.p.A.  
I-37045 Legnago (VR)  
Tel.: +39.0442.630111  
[http:// www.riello.it](http://www.riello.it)  
[http:// www.riello.com](http://www.riello.com)