

**GB Dual fuel light oil/ gas burners**

Progressive two-stage or modulating operation gas side/  
two-stage light oil side

**CE****UK  
CA****EAC**

CODE	MODEL	TYPE
20205611	RLS 160/M MX	781T
20206124	RLS 160/M MX	781T
20208617	RLS 160/M MX	781T



**Original instructions**

<b>1</b>	<b>Information and general warnings.....</b>	<b>3</b>
1.1	Information about the instruction manual .....	3
1.1.1	Introduction.....	3
1.1.2	General dangers.....	3
1.1.3	Other symbols .....	3
1.1.4	Delivery of the system and the instruction manual .....	4
1.2	Guarantee and responsibility.....	4
<b>2</b>	<b>Safety and prevention.....</b>	<b>5</b>
2.1	Introduction.....	5
2.2	Personnel training .....	5
<b>3</b>	<b>Technical description of the burner .....</b>	<b>6</b>
3.1	Burner designation .....	6
3.2	Models available.....	6
3.3	Burner categories - Countries of destination .....	7
3.4	Technical data .....	7
3.5	Electrical data.....	7
3.6	Burner equipment.....	8
3.7	Maximum dimensions.....	8
3.8	Firing rate .....	9
3.9	Test boiler.....	9
3.10	Commercial boilers.....	9
3.11	Burner description .....	10
3.12	Electrical panel description.....	11
3.13	Flame control (LFL.....)	12
3.14	Servomotor (SQN31.....)	13
3.15	Calibration of the thermal relay .....	14
3.16	Motor rotation .....	14
<b>4</b>	<b>Installation .....</b>	<b>15</b>
4.1	Notes on safety for the installation .....	15
4.2	Handling .....	15
4.3	Preliminary checks .....	15
4.4	Operating position .....	16
4.5	Preparing the boiler .....	16
4.5.1	Boring the boiler plate .....	16
4.5.2	Blast tube length.....	16
4.6	Securing the burner to the boiler .....	17
4.7	Electrode position .....	17
4.8	Choice of nozzles for the 1st and 2nd stage .....	18
4.9	Nozzle installation .....	19
4.10	Combustion head adjustment.....	20
4.11	Light oil supply.....	21
4.11.1	Double-pipe circuit.....	21
4.11.2	Loop circuit.....	21
4.11.3	Hydraulic connections .....	22
4.11.4	Hydraulic circuit diagram .....	22
4.11.5	Pump .....	23
4.11.6	Pump adjustment .....	23
4.11.7	Priming pump .....	23
4.12	Gas supply .....	24
4.12.1	Gas feeding line (Example) - Please refer to the gas train documentation .....	24
4.12.2	Gas train.....	25
4.12.3	Gas train installation.....	25
4.12.4	Gas pressure .....	25
4.13	Electrical connections.....	27

4.13.1	Supply cables and external connections passage .....	27
<b>5</b>	<b>Start-up, calibration and operation of the burner .....</b>	<b>28</b>
5.1	Notes on safety for the first start-up .....	28
5.2	Servomotor adjustment .....	28
5.3	Adjustments prior to ignition (light oil) .....	28
5.4	Burner start-up (light oil) .....	29
5.5	Burner ignition (light oil) .....	29
5.6	Burner adjustment (light oil) .....	29
5.6.1	Ignition .....	29
5.6.2	Operation .....	29
5.7	Adjustments prior to ignition (gas) .....	30
5.8	Burner start-up (gas) .....	30
5.9	Burner adjustment (gas) .....	31
5.9.1	Ignition output .....	31
5.9.2	Maximum output .....	31
5.9.3	Minimum output .....	32
5.9.4	Intermediate outputs .....	32
5.10	Pressure switch adjustment .....	33
5.10.1	Air pressure switch .....	33
5.10.2	Maximum gas pressure switch .....	33
5.10.3	Minimum gas pressure switch .....	33
5.11	Operation sequence of the burner (gas) .....	34
5.11.1	Burner start-up .....	34
5.11.2	Steady state operation .....	34
5.11.3	Ignition failure .....	34
5.12	Final checks (with burner operating) .....	35
<b>6</b>	<b>Maintenance .....</b>	<b>36</b>
6.1	Notes on safety for the maintenance .....	36
6.2	Maintenance programme .....	36
6.2.1	Maintenance frequency .....	36
6.2.2	Safety test - with no gas supply .....	36
6.2.3	Checking and cleaning .....	36
6.2.4	Safety components .....	37
6.3	Opening the burner .....	39
6.4	Closing the burner .....	39
<b>7</b>	<b>Faults - Possible causes - Solutions .....</b>	<b>40</b>
7.1	Light oil operation .....	41
7.2	Gas operation .....	43
<b>A</b>	<b>Appendix - Accessories .....</b>	<b>45</b>
<b>B</b>	<b>Appendix - Electrical panel layout .....</b>	<b>46</b>

**1 Information and general warnings**

**1.1 Information about the instruction manual**

**1.1.1 Introduction**

The instruction manual supplied with the burner:

- is an integral and essential part of the product and must not be separated from it; it must therefore be kept carefully for any necessary consultation and must accompany the burner even if it is transferred to another owner or user, or to another system. If the manual is lost or damaged, another copy must be requested from the Technical Assistance Centre of the area;
- is designed for use by qualified personnel;
- offers important indications and instructions relating to the installation safety, start-up, use and maintenance of the burner.

**Symbols used in the manual**

In some parts of the manual you will see triangular DANGER signs. Pay great attention to these, as they indicate a situation of potential danger.

**1.1.2 General dangers**

The **dangers** can be of **3 levels**, as indicated below.



Maximum danger level!  
This symbol indicates operations which, if not carried out correctly, cause serious injury, death or long-term health risks.



This symbol indicates operations which, if not carried out correctly, may cause serious injury, death or long-term health risks.



This symbol indicates operations which, if not carried out correctly, may cause damage to the machine and/or injury to people.

**1.1.3 Other symbols**



**DANGER: LIVE COMPONENTS**  
This symbol indicates operations which, if not carried out correctly, lead to electric shocks with lethal consequences.



**DANGER: FLAMMABLE MATERIAL**  
This symbol indicates the presence of flammable materials.



**DANGER: BURNING**  
This symbol indicates the risks of burns due to high temperatures.



**DANGER: CRUSHING OF LIMBS**  
This symbol indicates the presence of moving parts: danger of crushing of limbs.



**WARNING: MOVING PARTS**

This symbol indicates that you must keep limbs away from moving mechanical parts; danger of crushing.



**DANGER: EXPLOSION**

This symbol signals places where an explosive atmosphere may be present. An explosive atmosphere is defined as a mixture - under atmospheric conditions - of air and flammable substances in the form of gases, vapours, mist or dust in which, after ignition has occurred, combustion spreads to the entire unburned mixture.



**PERSONAL PROTECTION EQUIPMENT**

These symbols indicate the equipment that must be worn and kept by the operator for protection against threats against safety and/or health while at work.



**OBLIGATION TO ASSEMBLE THE COVER AND ALL THE SAFETY AND PROTECTION DEVICES**

This symbol signals the obligation to reassemble the cover and all the safety and protection devices of the burner after any maintenance, cleaning or checking operations.



**ENVIRONMENTAL PROTECTION**

This symbol gives indications for the use of the machine with respect for the environment.



**IMPORTANT INFORMATION**

This symbol indicates important information that you must bear in mind.

- This symbol indicates a list.

**Abbreviations used**

Ch.	Chapter
Fig.	Figure
Page	Page
Sec.	Section
Tab.	Table

### 1.1.4 Delivery of the system and the instruction manual

When the system is delivered, it is important that:

- the instruction manual is delivered to the user by the system manufacturer, with the recommendation to keep it in the room where the heat generator is to be installed.
- The instruction manual shows:
  - the serial number of the burner;

.....
-------

- the address and telephone number of the nearest Assistance Centre;

.....
.....
.....

- The system supplier must carefully inform the user about:
  - the use of the system;
  - any further tests that may be required before activating the system;
  - maintenance, and the need to have the system checked at least once a year by a representative of the manufacturer or another specialised technician.To ensure a periodic check, the manufacturer recommends the drawing up of a Maintenance Contract.

## 1.2 Guarantee and responsibility

The manufacturer guarantees its new products from the date of installation, in accordance with the regulations in force and/or the sales contract. At the moment of the first start-up, check that the burner is integral and complete.



**ATTENTION**

Failure to observe the information given in this manual, operating negligence, incorrect installation and carrying out of non authorised modifications will result in the annulment by the manufacturer of the guarantee that it supplies with the burner.

In particular, the rights to the guarantee and the responsibility will no longer be valid, in the event of damage to things or injury to people, if such damage/injury was due to any of the following causes:

- incorrect installation, start-up, use and maintenance of the burner;
- improper, incorrect or unreasonable use of the burner;
- intervention of unqualified personnel;
- carrying out of unauthorised modifications on the equipment;
- use of the burner with safety devices that are faulty, incorrectly applied and/or not working;
- installation of untested supplementary components on the burner;
- powering of the burner with unsuitable fuels;
- faults in the fuel supply system;
- continuation of use of the burner when a fault has occurred;
- repairs and/or overhauls incorrectly carried out;
- modification of the combustion chamber with inserts that prevent the regular development of the structurally established flame;
- insufficient and inappropriate surveillance and care of those burner components most likely to be subject to wear and tear;
- use of non-original components, including spare parts, kits, accessories and optional;
- force majeure.

**The manufacturer furthermore declines any and every responsibility for the failure to observe the contents of this manual.**

**2 Safety and prevention**

**2.1 Introduction**

The burners have been designed and built in compliance with current regulations and directives, applying the known technical safety rules and envisaging all the potential danger situations.

It is necessary, however, to bear in mind that the imprudent and clumsy use of the equipment may lead to situations of death risk for the user or third parties, as well as the damaging of the burner or other items. Inattention, thoughtlessness and excessive confidence often cause accidents; the same applies to tiredness and sleepiness.

It is a good idea to remember the following:

- The burner must only be used as expressly described. Any other use should be considered improper and therefore dangerous.

Specifically:

it can be applied to boilers operating with water, steam, diathermic oil, and to other uses expressly named by the manufacturer;

the type and pressure of the fuel, the voltage and frequency of the electrical power supply, the minimum and maximum deliveries for which the burner has been regulated, the pressurisation of the combustion chamber, the dimensions of the combustion chamber and the ambient temperature must all be within the values indicated in the instruction manual.

- Modification of the burner to alter its performance and destinations is not allowed.
- The burner must be used in exemplary technical safety conditions. Any disturbances that could compromise safety must be quickly eliminated.
- Opening or tampering with the burner components is not allowed, apart from the parts requiring maintenance.
- Only those parts envisaged by the manufacturer can be replaced.



The manufacturer guarantees safety and proper operation only if all burner components are intact and correctly positioned.

**2.2 Personnel training**

The user is the person, body or company that has acquired the machine and intends to use it for the specific purpose. He is responsible for the machine and for the training of the people working around it.

The user:

- undertakes to entrust the machine exclusively to suitably trained and qualified personnel;
- undertakes to inform his personnel in a suitable way about the application and observance of the safety instructions. With that aim, the user undertakes to ensure that everyone knows the use and safety instructions for his own duties;
- Personnel must observe all the danger and caution indications shown on the machine.
- Personnel must not carry out, on their own initiative, operations or interventions that are not within their province.
- Personnel must inform their superiors of every problem or dangerous situation that may arise.
- The assembly of parts of other makes, or any modifications, can alter the characteristics of the machine and hence compromise operating safety. The manufacturer therefore declines any and every responsibility for any damage that may be caused by the use of non-original parts.

In addition:



- must take all the measures necessary to prevent unauthorised people gaining access to the machine;
- the user must inform the manufacturer if faults or malfunctioning of the accident prevention systems are noticed, along with any presumed danger situation;
- personnel must always use the personal protective equipment envisaged by legislation and follow the indications given in this manual.

**3 Technical description of the burner**

**3.1 Burner designation**

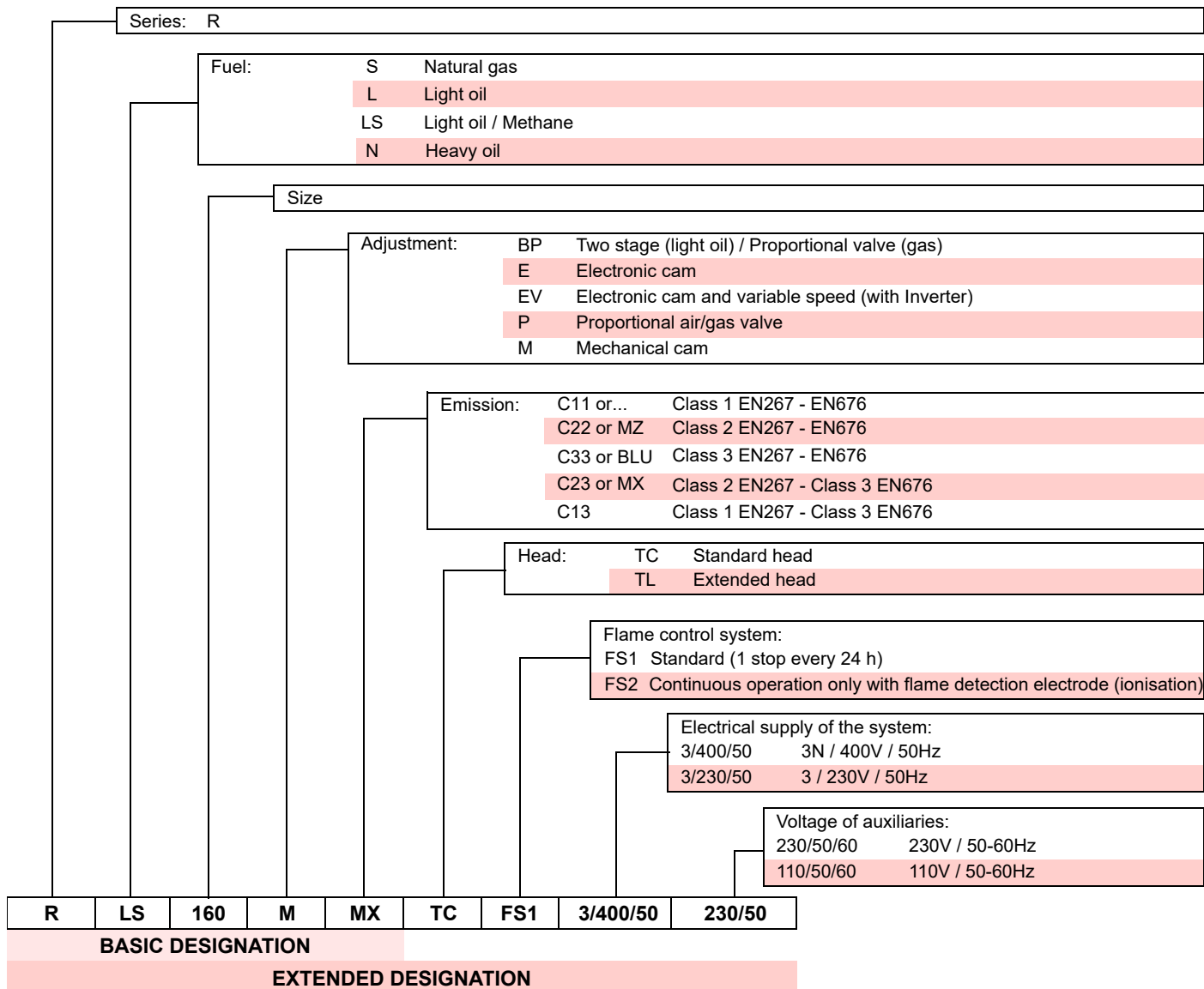

**3.2 Models available**

Designation	Voltage	Start-up	Code
RLS 160/M MX FS1	3/400/50	Direct	20205611
RLS 160/M MX FS1	3/400/50	Direct	20206124
RLS 160/M MX FS1	3/230/50	Direct	20208617

**Tab. A**

**3.3 Burner categories - Countries of destination**

Gas category	Country of destination
I2H	AT- BG- CH- CZ- DK- EE- ES- FI- GB- GR- HU- IE- IS- IT- LT- LV- NO- PT- RO- SE- SI- SK- TR
I2E(R)	BE
I2E	LU- PL
I2ELL	DE
I2EK	NL
I2Er	FR

**Tab. B**
**3.4 Technical data**

Model				RLS 160/M MX	
				Flame stability disc with round sectors 2)(Fig. 16)	Flame stability disc without round sectors 2)(Fig. 16)
Output <sup>(1)</sup> Delivery <sup>(1)</sup>	Light oil	2nd stage min - max	kW kg/h	965 - 1846 81 - 155	1132 - 2013 95 - 169
		1st stage min	kW kg/h	488 41	560 47
	Natural gas	2nd stage min - max	kW	940 - 1730	940 - 1840
		1st stage min	kW	300	300
Fuels				Light oil, max. viscosity at 20 °C: 6 mm <sup>2</sup> /s (1.5 °E - 6 cSt) Natural gas: G20 (methane gas) - G21 - G25	
Operation				– Intermittent FS1 (min. 1 stop in 24 hours) – Oil: two-stage (high and low flame) and one-stage (all - nothing) – Gas: progressive two-stage or modulating by kit (see ACCESSORIES)	
Nozzles			number	2	
Standard applications				Boilers: water, steam, diathermic oil	
Ambient temperature			°C	0 - 40	
Combustion air temperature			°C max	60	
Pump	output (at 20 bar)		kg/h	230	
	pressure range		bar	10 - 21	
	fuel temperature		°C max	90	
Noise levels <sup>(2)</sup>	Sound pressure		dB(A)	80.5	
	Sound power			91.5	
Weight of the burner complete with its packaging			kg	160	
CE				CE-0476DQ3601	

**Tab. C**

- (1) Reference conditions: Ambient temperature 20°C - Gas temperature 15°C - Barometric pressure 1013 mbar - Altitude 0 m a.s.l.  
 (2) Sound pressure measured in manufacturer's combustion laboratory, with burner operating on test boiler and at maximum output. The sound power is measured using the "Free Field" method, required by EN 15036 standard, and according to an "Accuracy: Category 3" measurement, as described in EN ISO 3746.

**3.5 Electrical data**

Model Code	RLS 160/M MX 20205611 - 20206124	RLS 160/M MX 20208617
Main electrical supply	3~ 400V +/-10%	3~ 230V +/-10%
Auxiliary circuit electrical supply	1N ~ 230V +/-10% - 50Hz	
Max. absorbed electric power	W	6300
Protection level	IP 44	

**Tab. D**

**3.6 Burner equipment**

Flange for gas train .....	No. 1
Seal for flange .....	No. 1
Screws M10x40 to fix the gas flange .....	No. 4
Thermal flange gasket .....	No. 1
Screws M16x40 to fix the burner flange to the boiler .....	No. 4
Flexible hoses .....	No. 2
Fittings for flexible hoses .....	No. 2
Seals .....	No. 2
Extensions for slide bars .....	No. 2
Spare parts list .....	No. 1
Instructions .....	No. 1



It is recommended to tighten the screws of the gas flange with a tightening torque of **30 Nm ±10%**.

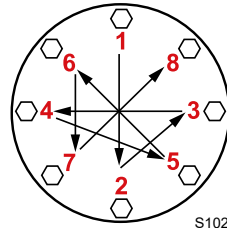

Tighten the nuts gradually (first to 30%, then to 60% up to 100%) according to the cross pattern shown in the figure.

S10230

**3.7 Maximum dimensions**

The dimensions of the burner are given in Fig. 1. Bear in mind that inspection of the combustion head requires the burner to be opened and the rear part turned on the hinge.

The maximum dimensions of the open burner are indicated by the U position.

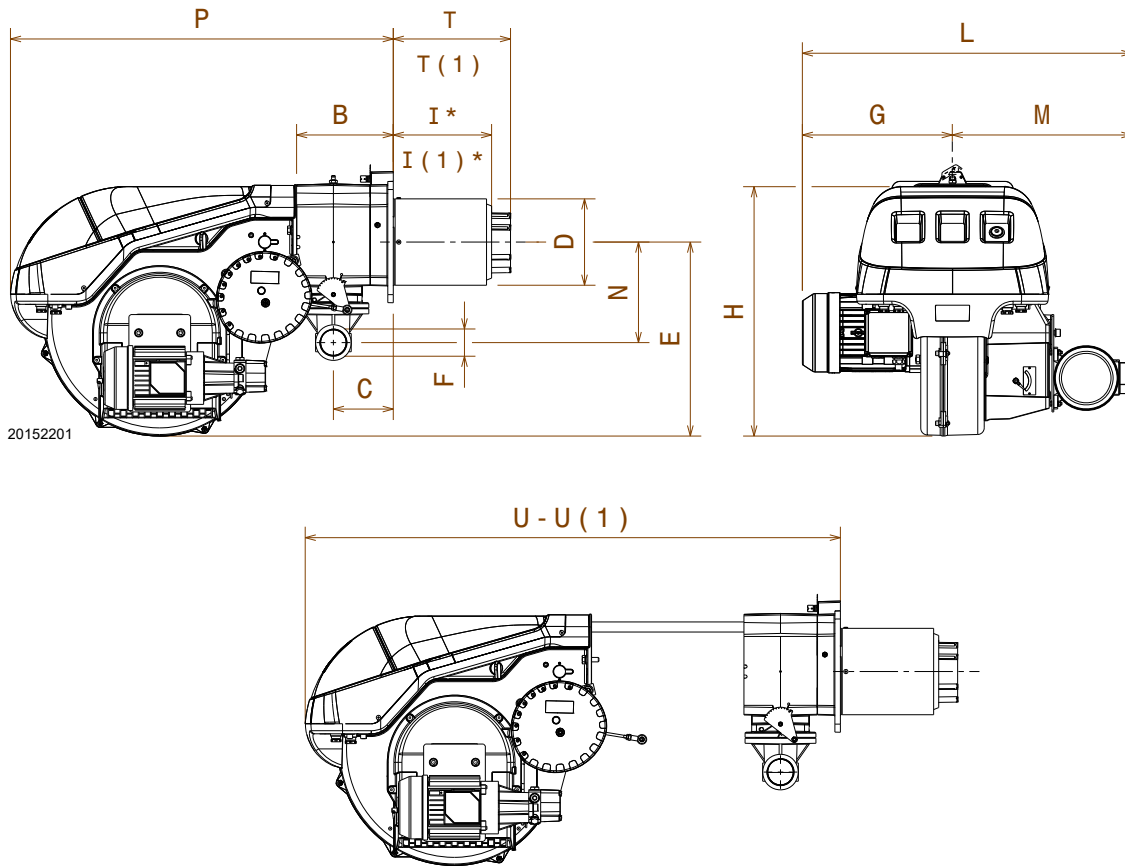

**Fig. 1**

mm	B	C	D	E	F	G	H	I* - I(1)*	L	M	N	P	T - T(1)	U - U(1)
RLS 160/M MX	237	141	221	430	2"	366	555	272-402	843	477	186	863	373-503	1442-1587

**Tab. E**

(\*) Blast tube: short-long

**3.8 Firing rate**

During operation, burner output varies between:

- **Maximum output**, selected from within area A.
- The **minimum output** must not be lower than the minimum limit of the diagram: **300 kW**



The firing rate value (Fig. 2) has been obtained considering an ambient temperature of 20 °C, an atmospheric pressure of 1013 mbar (approx. 0 m a.s.l.), and with the combustion head adjusted as shown on page 20.

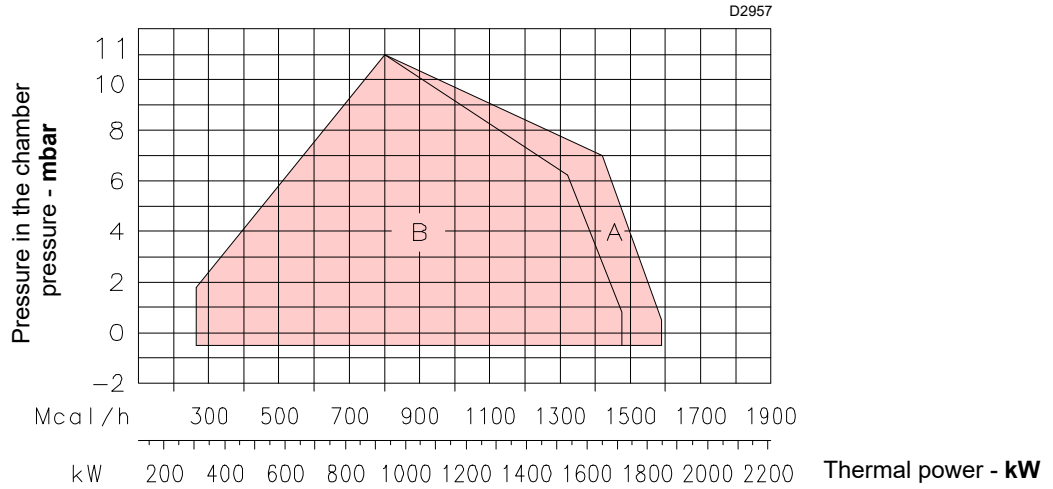

**Fig. 2**

**3.9 Test boiler**

The firing rates were obtained in special test boilers, according to EN 676 standard.

In Fig. 3 you can see the diameter and length of the test combustion chamber.

**Example:**  
Output 650 kW - diameter 60 cm  
length 2 m

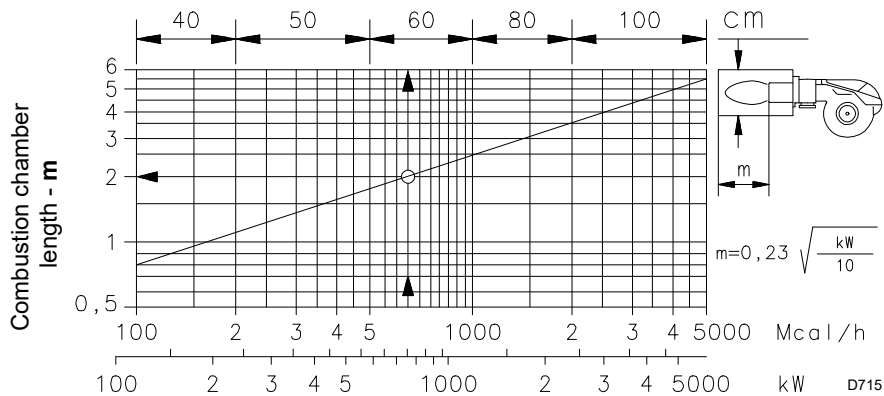

**Fig. 3**

**3.10 Commercial boilers**

Burners are suitable for operating on both flame inversion boilers (\*) as well as on boilers with a combustion chamber with run-off from the bottom (three flue passes) on which the best results for low NO<sub>x</sub> emissions are obtained.

The boiler front door maximum thickness must not exceed 250 mm (Fig. 4).

Although combination is guaranteed when boiler has a CE type-approval, preliminary tests are recommended for boilers or furnaces having a combustion chamber size much different than the one specified in the diagram (Fig. 3).

(\*) For flame inversion boilers, a kit is available to reduce the CO, if necessary.

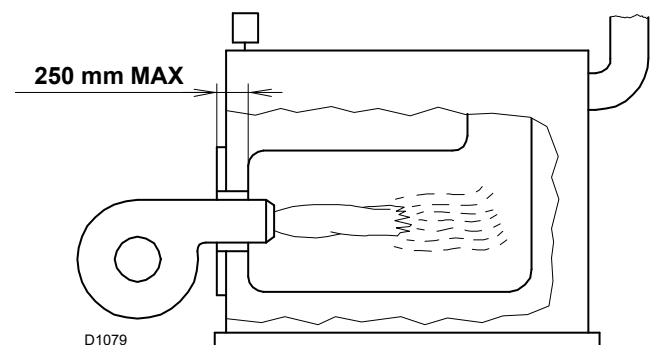

**Fig. 4**

3.11 Burner description

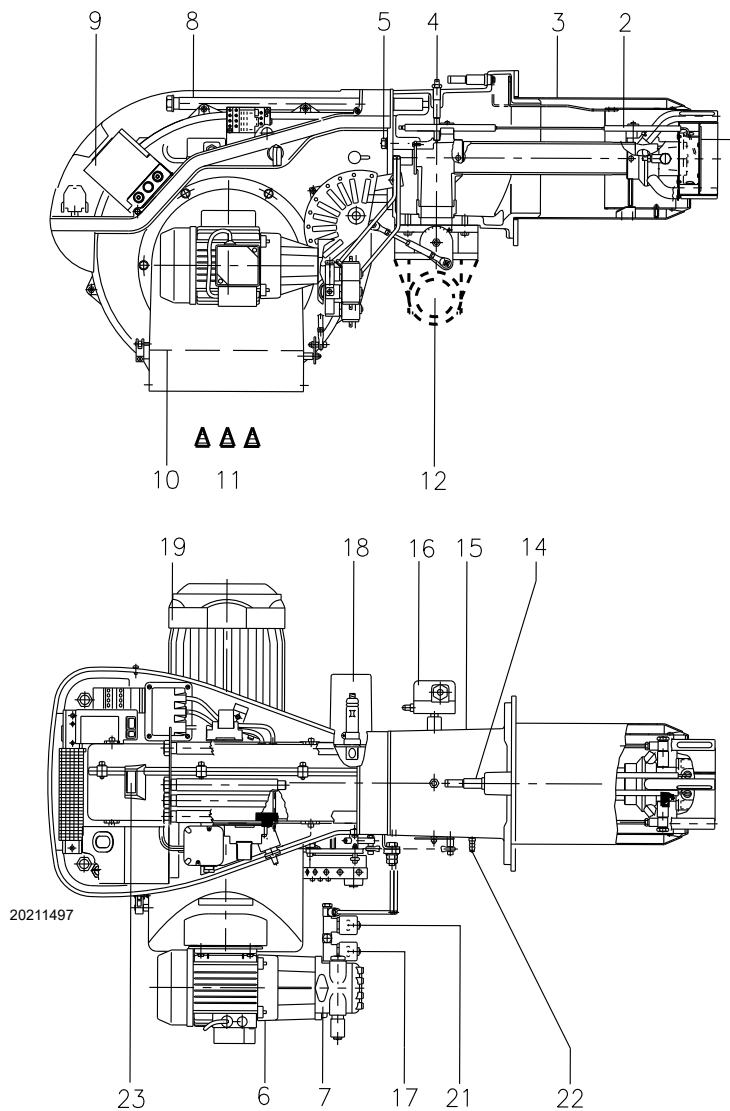
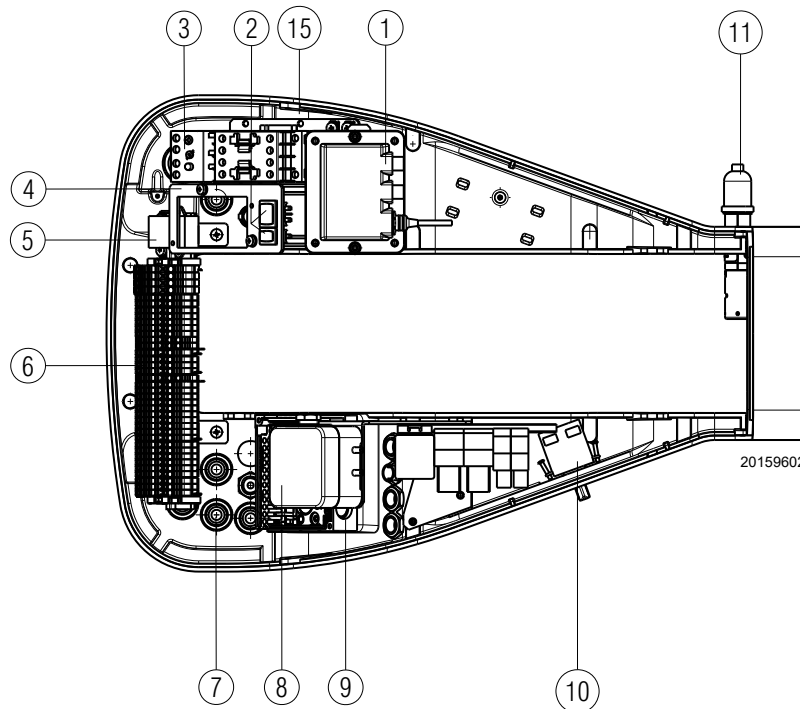
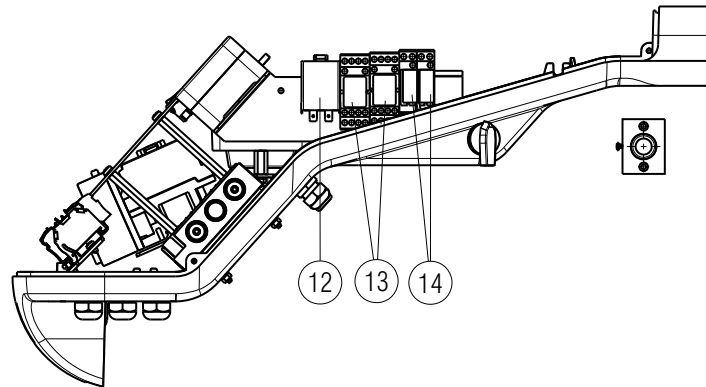

Fig. 5

- |    |  |    |                          |
|----|--|----|--------------------------|
| 1  | Flame stability disc   | 19 | Fan motor                |
| 2  | Ignition electrodes  | 21 | 1st and 2nd stage valves |
| 3  | Combustion head  | 22 | Air pressure test point  |
| 4  | Gas pressure test point and head fixing screw  | 23 | Flame inspection window  |
| 5  | Screws to secure fan to pipe coupling  |    |                          |
| 6  | Pump motor   |    |                          |
| 7  | Pump   |    |                          |
| 8  | Slide bars for opening the burner and inspecting the combustion head   |    |                          |
| 9  | Flame control with lockout pilot light and reset button  |    |                          |
| 10 | Air damper   |    |                          |
| 11 | Air inlet to fan   |    |                          |
| 12 | Gas input pipe   |    |                          |
| 14 | Screw for combustion head adjustment   |    |                          |
| 15 | Pipe coupling with flange for fixing to the boiler and the gas butterfly valve   |    |                          |
| 16 | Maximum gas pressure switch  |    |                          |
| 17 | Safety valve   |    |                          |
| 18 | Servomotor controlling the gas butterfly valve and the air damper, by means of a variable profile cam mechanism. When the burner is not operating the air damper is fully closed in order to reduce heat dispersion from the boiler due to the flue draught, which draws air from the fan suction inlet. |    |                          |

3.12 Electrical panel description



- 1 Ignition transformer
- 2 A switch for:  
automatic-manual-off operation  
A button for:  
output increase - decrease
- 3 Motor contactor and thermal relay with reset button
- 4 Bracket for application of RWF kit
- 5 Filter to protect against radio disturbance
- 6 Terminal board for electric connection
- 7 Cable grommets for external connections (to be carried out by the installer)
- 8 Air pressure switch (differential type)
- 9 Flame control base
- 10 Oil - gas switch
- 11 Flame sensor
- 12 Power relay
- 13 Relay
- 14 Dry contact relay
- 15 Plug to connect the RWF kit of modulating operation

**NOTE**

Two types of burner lockout may occur:

- **Flame control lockout:** if the flame control 9)(Fig. 5) push-button lights up, it indicates that the burner is in lockout. Press the push button to reset.
- **Motor lockout:** release by pressing the button on thermal relay 3)(Fig. 6).

**Fig. 6**

**3.13 Flame control (LFL...)**

**Important notes**



**ATTENTION**

To avoid accidents, material or environmental damage, observe the following instructions!

The flame control LFL1... is a safety device! Avoid opening or modifying it, or forcing its operation. Riello S.p.A. cannot assume any responsibility for damage resulting from unauthorised interventions!

- All interventions (assembly and installation operations, assistance, etc.) must be carried out by qualified personnel.
- Before modifying the wiring in the LFL1... flame control connection area, fully disconnect the system from the power supply (omnipolar separation).
- Protection against electrocution from the flame control and all connected electric components is obtained with the correct assembly.
- Before any intervention (assembly and installation operations, assistance, etc.), ensure the wiring is in order and that the parameters are correctly set, then make the safety checks.
- Falls and collisions can negatively affect the safety functions. In this case, the flame control must not be operated, even if it displays no evident damage.
- **Do not press the reset button or the remote reset button of the flame control for more than 10 seconds because this will damage the internal relay.**

For safety and reliability, comply with the following instructions:

- Avoid conditions that can favour the development of condensate and humidity. Otherwise, before switching on again, make sure that the entire flame control is perfectly dry!
- Static charges must be avoided since they can damage the flame control's electronic components when touched.

**Use**

The LFL1... flame control is a control and supervision system of medium and large capacity forced draft burners for intermittent operation (at least one controlled shutdown every 24 hours).

**Installation notes**

- Check the electrical wiring inside the boiler complies with the national and local safety regulations.
- Do not confuse the powered conductors with the neutral ones.
- Ensure that spliced wires cannot get into contact with neighbouring terminals. Use adequate ferrules.
- Arrange the H.V. ignition cables separately, as far as possible from the flame control and the other cables.
- When wiring the unit, make sure that AC 230 V mains voltage cables are run strictly separate from extra low-voltage cables to avoid risks of electrical shock hazard.

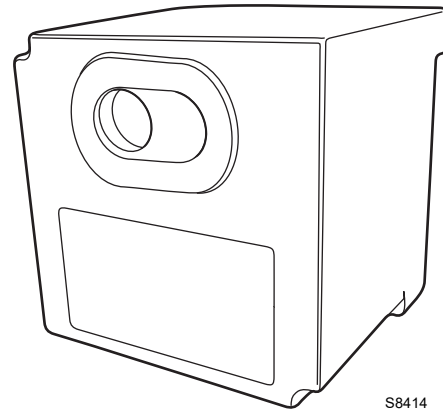

S8414

**Fig. 7**

**Electrical wiring of the flame detector**

It is important for signal transmission to be almost totally free of any disturbances or loss:

- Always separate the detector cables from the other cables:
  - The capacitive reactance of the line reduces the size of the flame signal.
  - Use a separate cable.
- Respect the allowed cable lengths.
- The ionisation probe is not protected against the risk of electrocution. When connected to the electricity supply, the ionisation probe must be protected against any accidental contact.
- Position the ignition electrode and the ionisation probe so that the ignition spark cannot form an arc on the probe (risk of electric overcharge).

**Technical data**

Mains voltage	AC 230 V -15 % / +10 %
Mains frequency	50 / 60 Hz ±6 %
Fuse (Internal)	T6.3H250V
Primary fuse (external)	max. 10 A
Weight	approx. 1 kg
Power absorption	approx. AC 3.5 VA
Protection level	IP40
Safety class	II
Input current at terminal 1	max. 5 A continuous (peaks of 20 A / 20 ms)
Load on the control terminals	max. 4 A continuous (peaks of 20 A / 20 ms)
<b>Environmental conditions</b>	
Operation	DIN EN 60721-3-1
Climatic conditions	Class 1K3
Mechanical conditions	Class 1M2
Temperature range	-20...+60°C
Humidity	< 95% RH

**Tab. F**

**3.14 Servomotor (SQN31...)**

**Important notes**



To avoid accidents, material or environmental damage, observe the following instructions!

Avoid opening, modifying or forcing the actuators.

- All interventions (assembly and installation operations, assistance, etc.) must be carried out by qualified personnel.
- Before modifying the wiring in the connection area of the servomotor, fully disconnect the burner control device from the power supply (omnipolar separation).
- To avoid the risk of electrocution, protect the connection terminals in a suitable manner and correctly fix the cover.
- Check the wiring is in order.
- Falls and collisions can negatively affect the safety functions. In this case, the servomotor must not be operated, even if it displays no evident damage.

**Assembly notes**

- Check the relevant national safety standards are respected.
- When assembling the servomotor and connecting the damper, the gears can be disengaged by means of a lever, allowing the drive shaft to be easily adjusted in both directions of rotation.



20160309

**Fig. 8**

**Technical data**

Operating voltage	AC 220...240 V - 15% / +10% AC 100...110 V - 15% / +10%
Mains frequency	50...60 Hz ± 6%
Switching capacity of auxiliary devices and limit switches	10 (3) A, AC 24...250 V
Angle positioning	up to 160° (full scale)
Assembly position	option
Protection level	IP 54, DIN 40050
Safety class	I
Weight	approx. 0.8 kg
Actuator motor	synchronous motor
Power absorption	6.5 VA
Environmental conditions:	
Operation	DIN EN 60 721-3-1
Climatic conditions	Class 1K2
Mechanical conditions	Class 1M2
Temperature range	-20...+60°C
Humidity	< 95% RH

**Tab. G**

**3.15 Calibration of the thermal relay**

The thermal relay (Fig. 9) serves to avoid damage to the motor due to an excessive absorption increase or if a phase is missing. For calibration 2), refer to the table indicated in the electrical layout (electrical wiring by the installer).

To reset, in case of thermal relay activation, press the "RESET" button 1). The button "STOP" 3) opens the NC contact (95-96) and stops the motor. Insert a screwdriver in the window "TEST/TRIP" 4) and move it in the arrow direction (to the right) to carry out the thermal relay test.

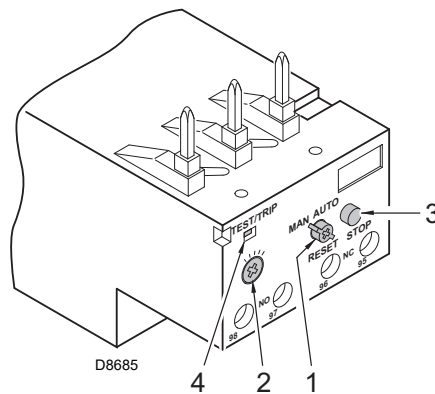

**Fig. 9**



The automatic reset can be dangerous. This operation is not foreseen in the burner operation.

**3.16 Motor rotation**

As soon as the burner starts, place yourself in front of the cooling fan of the fan motor and check that it turns anticlockwise (Fig. 10).

If this is not the case:

- put the switch of the burner to "0" (off) and wait until the flame control carries out the switching off phase.



Disconnect the electrical supply from the burner by means of the system main switch.

- Invert the phases on the three-phase motor power supply.

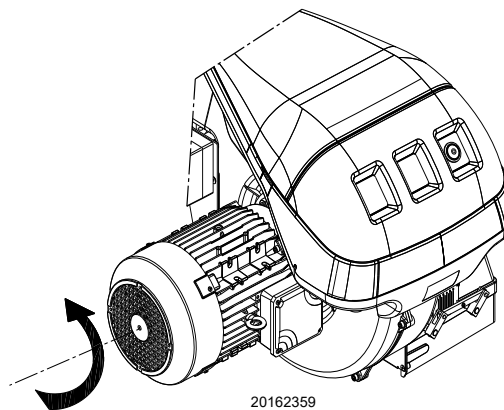

**Fig. 10**

**4 Installation**

**4.1 Notes on safety for the installation**

After carefully cleaning all around the area where the burner is to be installed, and arranging for the environment to be illuminated correctly, proceed with the installation operations.



All the installation, maintenance and disassembly operations must be carried out with the electricity supply disconnected.



The installation of the burner must be carried out by qualified personnel, as indicated in this manual and in compliance with the standards and regulations of the laws in force.



The combustion air inside the boiler must be free from hazardous mixes (e.g.: chloride, fluoride, halogen); if present, it is highly recommended to carry out cleaning and maintenance more frequently.

**4.2 Handling**

The burner packaging includes a wooden platform, it is therefore possible to handle the burner (still packaged) with a pallet truck or fork lift truck.



Burner handling operations can be highly dangerous if not carried out with the greatest attention: distance unauthorised personnel, check integrity and suitability of the means available. Check also that the area in which you are working is empty and that there is an adequate escape area (i.e. a free, safe area to which you can quickly move if the burner should fall). During handling, keep the load at no more than 20-25 cm from the ground.



After positioning the burner near the installation point, correctly dispose of all residual packaging, separating the various types of material.



Before proceeding with the installation operations, carefully clean all around the area where the burner will be installed.

**4.3 Preliminary checks**

**Checking the consignment**



After removing all the packaging, check the integrity of the contents. In the event of doubt, do not use the burner; contact the supplier.



The packaging elements (wooden cage or cardboard box, nails, clips, plastic bags, etc.) must not be abandoned as they are potential sources of danger and pollution; they should be collected and disposed of in the appropriate places.

		A		B	
		D		C	
		E		F	
GAS-KAASU	<input type="checkbox"/> FAM.2	G		H	
GAZ-AEPIO	<input type="checkbox"/> FAM.3	G		H	
		I			
		L			
				CE	
					

20206732

**Fig. 11**

**Checking the characteristics of the burner**

Check the identification label of the burner, showing:

- the model (A) (Fig. 11) and type of burner (B);
- the year of manufacture, in cryptographic form (C);
- the serial number (D);
- the data for electrical supply and the protection level (E);
- the absorbed electrical power (F);
- the types of gas used and the relative supply pressures (G);
- the data of the burner's minimum and maximum output possibilities (H) (see Firing rate).

**Warning.** The burner output must be within the firing rate of the boiler;

- the category of the appliance/countries of destination (I).
- light oil maximum viscosity (L).



A burner label that has been tampered with, removed or is missing, along with anything else that prevents the definite identification of the burner makes any installation or maintenance work difficult

### 4.4 Operating position



- The burner is designed to operate only in positions **1**, **2**, **3** and **4** (Fig. 12).
- Installation **1** is preferable, as it is the only one that allows the maintenance operations as described in this manual.
- Installations **2**, **3** and **4** allow operation but make maintenance and inspection of the combustion head more difficult.



- Any other position could compromise the correct operation of the appliance.
- The installation **5** is prohibited for safety reasons.

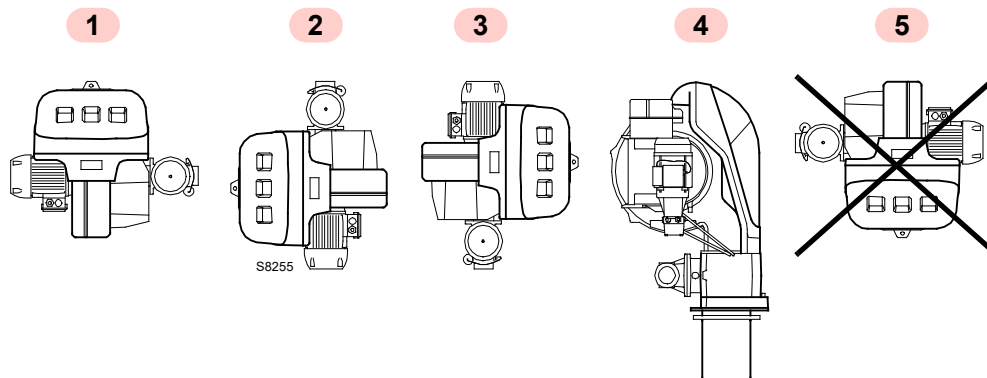

Fig. 12

### 4.5 Preparing the boiler

#### 4.5.1 Boring the boiler plate

Pierce the closing plate of the combustion chamber, as in Fig. 13.

The position of the threaded holes can be marked using the thermal insulation screen supplied with the burner.

mm	A	B	C
RLS 160/M MX	230	325 - 368	M 16

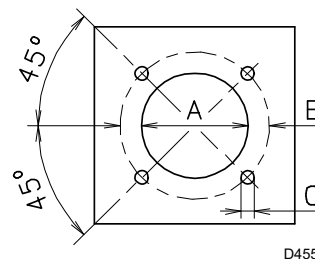

Fig. 13

#### 4.5.2 Blast tube length

The length of the blast tube must be selected according to the indications provided by the manufacturer of the boiler, and in any case it must be greater than the thickness of the boiler door complete with its fettling.

RLS 160/M MX	A
standard	373
elongated	503

For boilers with front flue passes 15)(Fig. 14), or flame inversion chamber, a protection in refractory material 13) must be inserted between the boiler fettling 14) and the blast tube 12).

This protection must not compromise the extraction of the blast tube.

**4.6 Securing the burner to the boiler**

Provide an adequate lifting system. Separate the combustion head from the rest of the burner, Fig. 14:

- disconnect the light oil pipes unscrewing the two unions 6);
- disengage the articulated coupling 7) from the graduated sector 8);
- loosen the 4 screws 3) and remove the hood 1);
- remove the screws 2) from the two slide bars 5);
- remove the two screws 4) and pull the burner back on slide bars 5) by about 100 mm;
- disconnect the electrode cables, then completely unthread the burner from the slide bars.

Fix the pipe coupling with the flange 11)(Fig. 14) to the boiler plate interposing the insulating gasket 9)(Fig. 14) supplied with the equipment. Use the 4 screws, also supplied, after protecting their thread with an anti-locking product.



**The seal between burner and boiler must be airtight.**

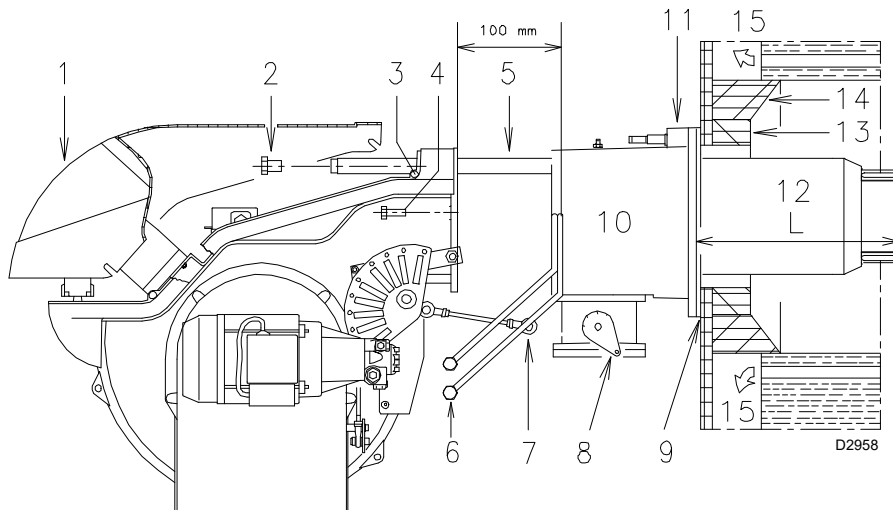
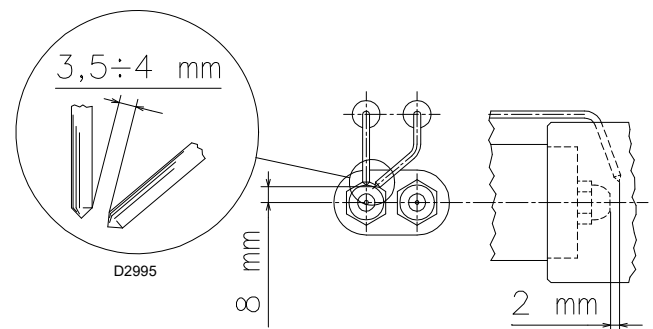

**Fig. 14**

**4.7 Electrode position**



Position the ignition electrode according to the dimensions shown in Fig. 15.



**Fig. 15**

### 4.8 Choice of nozzles for the 1st and 2nd stage

Both nozzles must be chosen from among those listed in Tab. H.

The first nozzle determines the delivery of the burner at the 1st stage.

The second nozzle works together with the 1st nozzle to determine the delivery of the burner in the 2nd stage.

The outputs of the 1st and 2nd stage have to be within the value range indicated in Tab. C on page 7.

Use nozzles with a 60° spray angle at the recommended pressure of 12 bar.

Generally the two nozzles have the same flow rate but the nozzle of the 1st stage can have an output that is 50% lower than the total output, when you want to reduce the back pressure peak on ignition (the burner provides good combustion values also with 40 - 100% ratios between the 1st and 2nd stage).

**Example:**

Boiler power = 1630 kW - efficiency 90 %

Burner requested output =  $1630 : 0.9 = 1812$  kW;

$1812 : 2 = 906$  kW per nozzle

so two equal nozzles of 60°, 12 bar are required:

- 1° = 18 GPH
- 2° = 18 GPH

or the following two different nozzles:

- 1° = 16 GPH
- 2° = 20 GPH

GPH	kg/h			kW 12 bar
	10 bar	12 bar	14 bar	
10.0	38.4	42.4	46.1	502.9
10.5	40.4	44.6	48.4	529.0
11.0	42.3	46.7	50.7	553.9
12.0	46.1	50.9	55.3	603.7
12.3	47.3	52.2	56.7	619.1
13.0	50.0	55.1	59.9	653.5
13.8	53.1	58.5	63.3	693.8
14.0	53.8	59.4	64.5	704.5
15.0	57.7	63.6	69.2	754.3
15.3	58.8	64.9	70.5	769.7
16.0	61.5	67.9	73.8	805.3
17.0	65.4	72.1	78.4	855.1
17.5	67.3	74.2	80.7	880.0
18.0	69.2	76.4	83.0	906.1
19.0	73.0	80.6	87.6	956.0
19.5	75.0	82.7	89.9	980.9
20.0	76.9	84.8	92.2	1005.8
21.5	82.7	91.2	99.1	1081.7
22.0	84.6	93.3	101.4	1106.6
22.5	86.5	95.5	103.7	1132.6
23.0	88.4	97.6	106.0	1157.5
23.5	90.4	99.7	108.3	1182.4
24.0	92.2	101.8	110.6	1207.3
24.5	94.2	104.0	112.9	1233.5
25.0	96.1	106.0	115.3	1257.2
25.5	98.0	108.2	117.6	1283.2
26.0	99.9	110.3	119.9	1308.2
26.5	101.9	112.4	122.2	1333.1
27.0	103.8	114.5	124.5	1358.0
27.5	105.7	116.7	126.8	1384.1
28.0	107.6	118.8	129.1	1409.0

Tab. H

**4.9 Nozzle installation**

The burner complies with the emission requirements of the EN 267 standard. In order to guarantee that emissions do not vary, recommended and/or alternative nozzles specified by Riello in the Instruction and warning booklet should be used.



It is advisable to replace the nozzle once a year during periodical maintenance.



The use of nozzles other than those specified by Riello S.p.A. and inadequate regular maintenance may result into emission limits non-conforming to the values set forth by the regulations in force, and in extremely serious cases, into potential hazards to people and objects.

The manufacturing Company shall not be liable for any such damage arising from non-observance of the requirements contained in this manual.

Remove the screw 1)(Fig. 16) and extract the internal part 2)(Fig. 16). Assemble the two nozzles with the socket spanner 1)(Fig. 17) (16 mm), after removing the plastic plugs 2)(Fig. 17), passing through the central opening of the flame stability disc. Alternatively, loosen the screws 1)(Fig. 18), remove the disc 2)(Fig. 18), and replace the nozzles using the spanner 3)(Fig. 18).

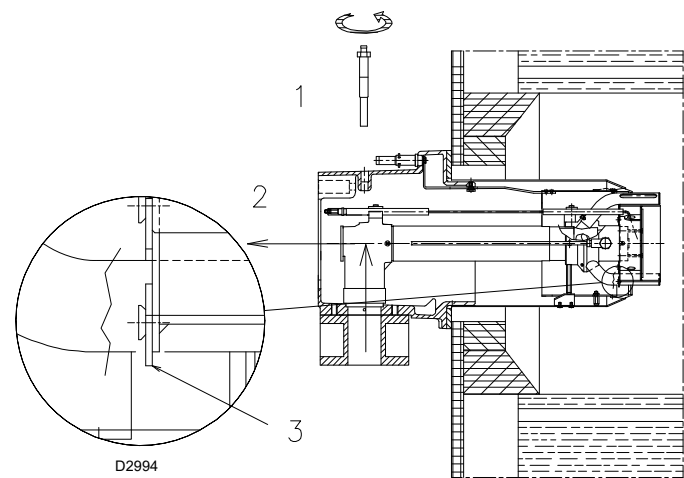

**Fig. 16**

Do not use any sealing products such as: gaskets, tape or sealants. Be careful to avoid damaging the nozzle sealing seat. The nozzle must be screwed into place tightly but not to the maximum torque value provided by the wrench.

The nozzle for the 1st stage of operation is the one beneath the ignition electrodes, Fig. 15.

Check that the electrodes are placed as in Fig. 15.

Reassemble the burner on the guides 3)(Fig. 19) at about 100 mm from the pipe coupling 4)(Fig. 19); see in the position shown in Fig. 14.

Insert the electrode cables and then slide the burner up to the pipe coupling, the burner in the position indicated in Fig. 19.

Refit screws 2) on slide bars 3)(Fig. 19).

Fix the burner to the pipe coupling with screws 1)(Fig. 19).

Reconnect the light oil pipes by screwing the two fittings 6)(Fig. 14).

Reconnect the articulated coupling 7) to the graduated sector 5)(Fig. 19).



- Do not use any sealing products such as: gaskets, tape or sealants.
- Be careful to avoid damaging the nozzle sealing seat.
- The nozzle must be screwed into place tightly but not to the maximum torque value provided by the wrench.
- On closing the burner on the two guides it is advisable to gently pull the high voltage wires outwards until they are under slight tension.

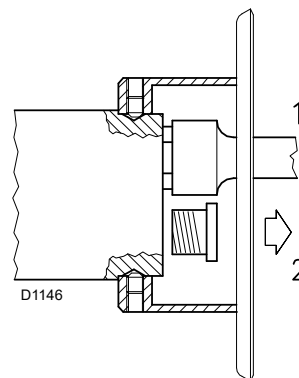

**Fig. 17**

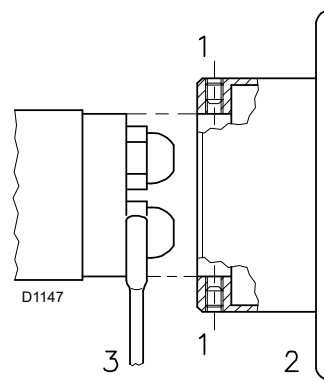

**Fig. 18**

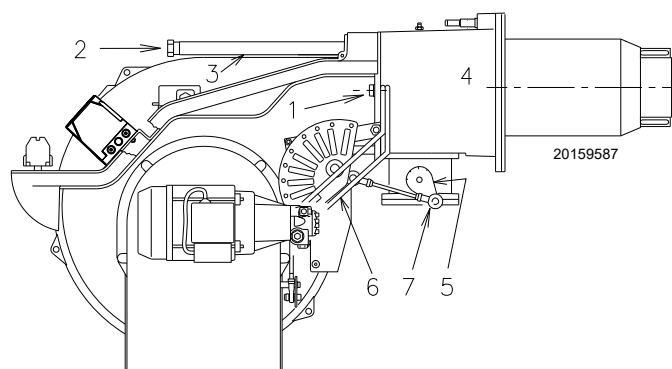

**Fig. 19**

**4.10 Combustion head adjustment**

The adjustment of the combustion head depends only on the maximum output of the burner.

Turn the screw 5(Fig. 20) until the notch indicated in diagram (Fig. 21) corresponds with the front part of the flange 6(Fig. 20).



**ATTENTION**

To facilitate the adjustment, loosen the screw 1)(Fig. 16), adjust, then block.

Example:

Burner maximum output = 1500 kW.

The diagram (Fig. 21) shows that for this output, the adjustment of the combustion head is carried out on notch 7.

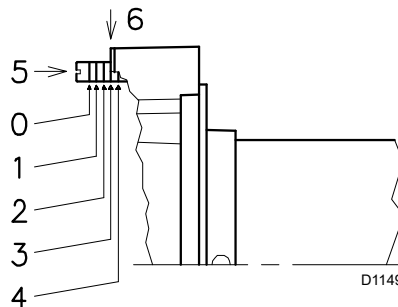

**Fig. 20**

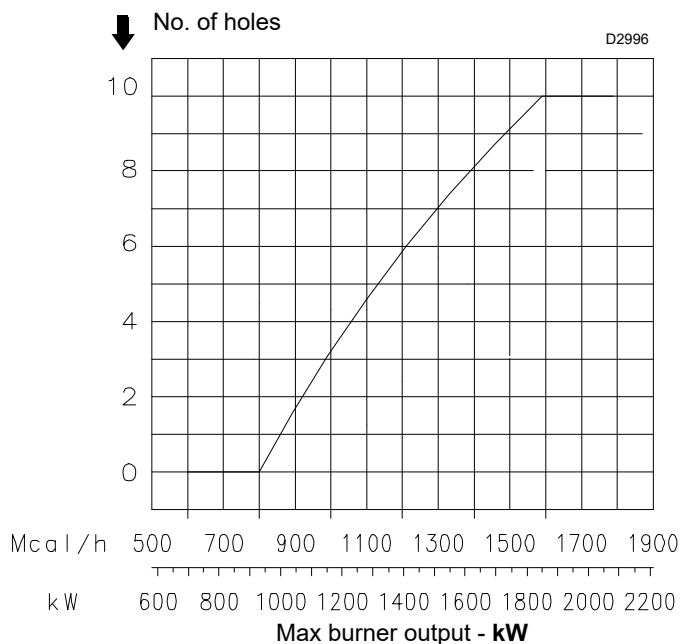

**Fig. 21**

**4.11 Light oil supply**



Explosion danger due to fuel leaks in the presence of a flammable source.

Precautions: avoid knocking, attrition, sparks and heat.

Make sure the fuel shut-off valve is closed before performing any operation on the burner.



ATTENTION

The fuel supply line must be installed by qualified personnel, in compliance with current standards and laws.

**4.11.1 Double-pipe circuit**

The burner is equipped with a self-priming pump which is capable of supplying itself within the limits listed in the Tab. I.

**Tank higher than burner A (Fig. 22)**

Distance P must not exceed 10 meters in order to avoid straining the pump's seal; distance V must not exceed 4 meters in order to allow the self-priming of the pump even when the tank is almost empty.

**Tank lower than burner B (Fig. 22)**

The pump depression value must not exceed 0.45 bar (35 cm Hg). Because at higher levels gas is released from the fuel; the pump becomes noisy and its lifetime is shortened. It is good practice to ensure that the return and suction lines enter the burner from the same height; the suction line is more difficult to disconnect.

**4.11.2 Loop circuit**

The loop circuit is composed of a duct starting from the tank and going back to it, in which an auxiliary pump makes the pressurised fuel flow.

A branch from the loop supplies the burner.

This circuit is extremely useful whenever the burner pump does not succeed in self-priming because the tank distance and/or height difference are higher than the values listed in Tab. I.

H (m)	L (m)		
	Ø (mm)		
	12	14	16
4	71	138	150
3	62	122	150
2	53	106	150
1	44	90	150
0.5	40	82	150
0	36	74	137
-0.5	32	66	123
-1	28	58	109
-2	19	42	81
-3	10	26	53
-4	-	10	25

Tab. I

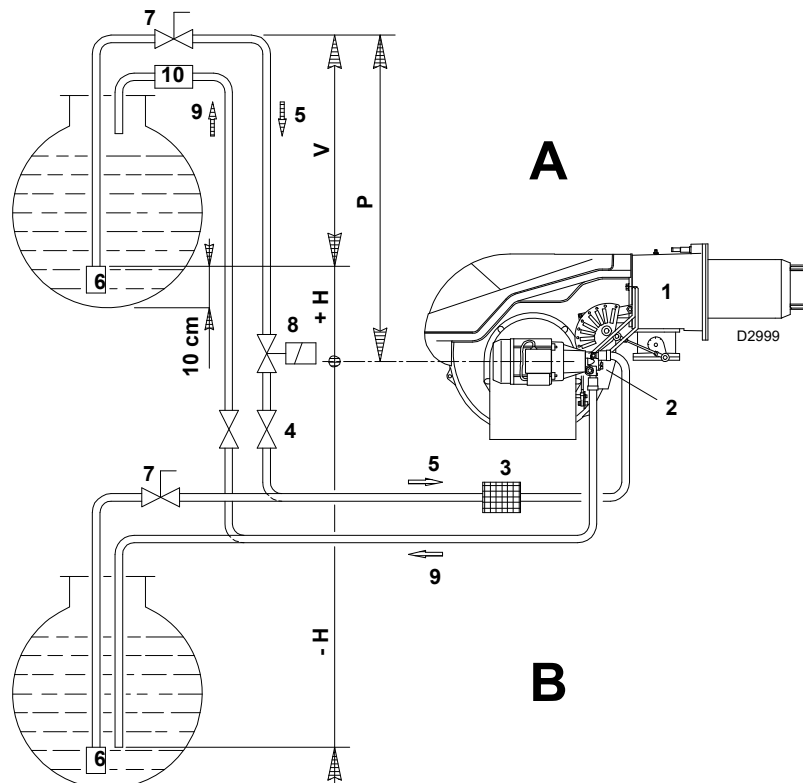

Fig. 22

**Key (Fig. 22)**

- H = Pump/Foot valve height difference
- L = Piping length
- Ø = Inside pipe diameter
- 1 = Burner
- 2 = Pump
- 3 = Filter
- 4 = Manual on/off valve
- 5 = Suction line

- 6 = Foot valve
- 7 = Quick closing manual valve with remote control (Italy only)
- 8 = On/off solenoid valve (Italy only). See electrical diagram. Connections to be carried out by the installer (SV).
- 9 = Return line
- 10 = Check valve (Italy only)

### 4.11.3 Hydraulic connections

The pumps are equipped with a by-pass that connects return line with suction line.

They are installed on the burner with the by-pass closed by screw 6)(Fig. 24).

It is therefore necessary to connect both hoses to the pump.

The pump will break down immediately if it is run with the return line closed and the by-pass screw inserted.

Remove plugs from suction and return connectors of the pump.  
Insert the hose connections with the supplied seals into the connections and screw them down.

During the installation, hoses must not be stressed with twisting.  
Position hoses so that they cannot be stepped on or get into contact with hot parts of the boiler and so that they allow burner opening.

Connect, finally, the other end of the flexible hoses to the suction and return lines using nipples supplied with the equipment.

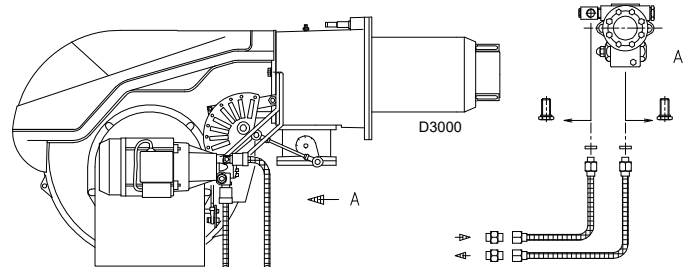

Fig. 23

### 4.11.4 Hydraulic circuit diagram

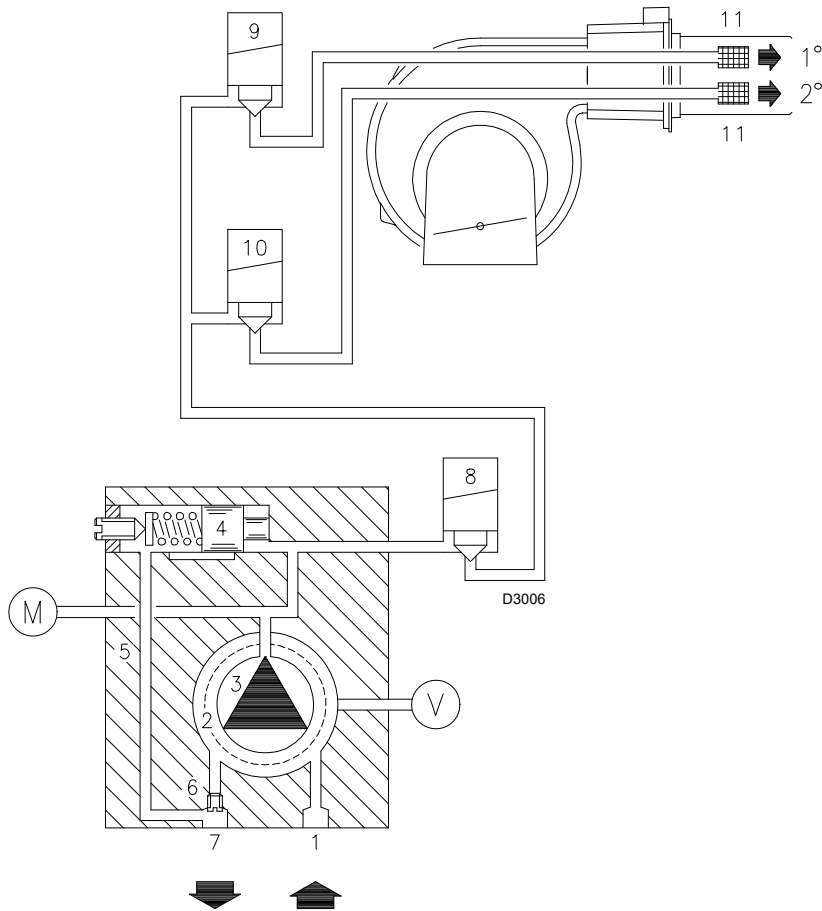

Fig. 24

#### Key (Fig. 24)

- 1 Pump suction line
- 2 Filter
- 3 Pump
- 4 Pump pressure regulator
- 5 Return pipe
- 6 Bypass screw
- 7 Pump return line
- 8 Safety valve
- 9 1st stage valve
- 10 2nd stage valve
- 11 Filter
- M Pressure gauge
- V Vacuumeter connection

**4.11.5 Pump**

**Technical data**

**PUMP J7 C**

Min. delivery rate at 12 bar pressure	230 kg/h
Delivery pressure range	10 - 21 bar
Max. suction depression	0.45 bar
Viscosity range	2.8 - 200 cSt
Max. light oil temperature	90 °C
Max. suction and return pressure	1.5 bar
Pressure calibration in the factory	12 bar
Filter mesh width	0.170 mm

**Tab. J**

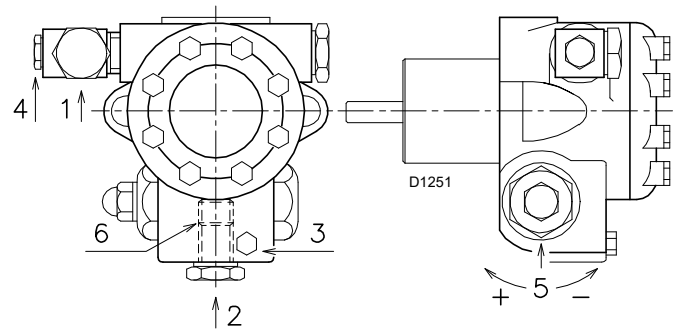

**Fig. 25**

**Key (Fig. 25)**

- |   |                           |        |
|---|---------------------------|--------|
| 1 | Suction line              | G 1/2" |
| 2 | Return line               | G 1/2" |
| 3 | Pressure gauge connection | G 1/8" |
| 4 | Vacuum meter connection   | G 1/8" |
| 5 | Pressure adjuster         |        |
| 6 | By-pass screw             |        |

**4.11.6 Pump adjustment**

No adjustment of gas delivery is required.

The pump leaves the factory set at 12 bar, a pressure to be checked and eventually modified after the burner has been started. In this phase, therefore, limit to apply a pressure gauge on the specific pump connector.

It may be necessary to adjust the pump to:

10 bar in order to reduce fuel delivery.

It is possible only if the ambient temperature remains above 0 °C;

14 bar in order to increase fuel delivery or to ensure firings even at temperatures of less than 0 °C.



**ATTENTION**

The above-mentioned operation is possible because the pump is already full of fuel when it leaves the factory. If the pump has been drained, fill it with fuel through the opening on the vacuum meter prior to starting; otherwise, the pump will seize.

Whenever the length of the suction piping exceeds 20-30 meters, the supply line must be filled using a separate pump.

**4.11.7 Priming pump**



**ATTENTION**

Before starting the burner, make sure that the tank return line is not clogged.

Obstructions in the line could cause the sealing organ located on the pump shaft to break. (The pump leaves the factory with the by-pass closed).

- Make sure that the valves on the suction line are open and that there is fuel in the tank.
- In order for self-priming to take place the screw 3)(Fig. 25) of the pump (Fig. 25) must be loosened in order to bleed off the air contained in the suction line.
- Start the burner by closing the control devices, with the switch 1)(Fig. 26) in "MAN" position and switch 10)(Fig. 6) in "OIL" position.
- The pump can be considered primed when the light oil starts coming out of the screw 3)(Fig. 25). Stop the burner: set switch 1)(Fig. 26) to "OFF" and tighten the screw 3)(Fig. 25).
- The time required for this operation depends upon the diameter and length of the suction tubing. If the pump fails to prime at the first starting of the burner and the burner locks out, wait approx. 15 seconds, reset the burner, and then repeat the starting operation as often as required. And so on.
- After 5 or 6 starting operations allow 2 or 3 minutes for the transformer to cool.
- Do not light the flame sensor in order to prevent the burner lockout; the burner locks out in any case about ten second after its start.

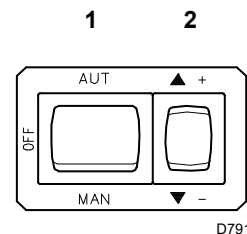

**Fig. 26**

**4.12 Gas supply**



Explosion danger due to fuel leaks in the presence of a flammable source.

Precautions: avoid knocking, attrition, sparks and heat.

Make sure the fuel shut-off valve is closed before performing any operation on the burner.



The fuel supply line must be installed by qualified personnel, in compliance with current standards and laws.

**4.12.1 Gas feeding line (Example) - Please refer to the gas train documentation for more information**

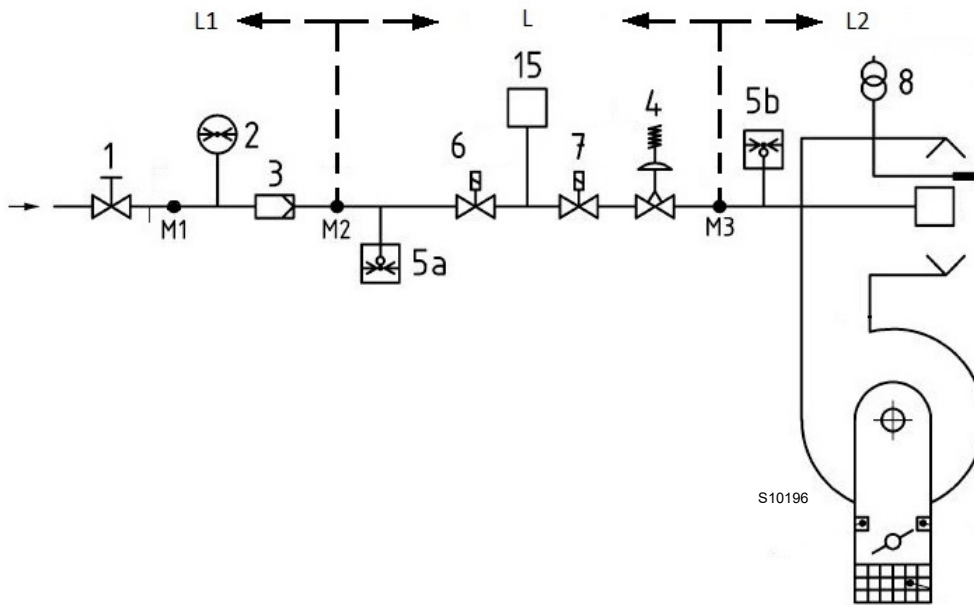

**Fig. 27**

Key (Fig. 27)

- 1 Manually operated shut-off valve
- 2 Pressure gauge
- 3 Filter
- 4 Governor
- 5a Low pressure protection device
- 5b Maximum gas pressure switch
- 6 1st safety shut-off device
- 7 2nd safety shut-off device
- 8 Ignition device
- 15 Valve leak detection control system
- L Gas train (supplied separately)
- L1 Responsibility of the installer
- L2 Burner
- M1 Pressure test point
- M2 Pressure test point
- M3 Pressure test point

**4.12.2 Gas train**

Type-approved in accordance with EN 676 and supplied separately from the burner.

**4.12.3 Gas train installation**



Disconnect the power supply using the system main switch.



Check that there are no gas leaks.



Pay attention when handling the train: danger of crushing of limbs.



Make sure that the gas train is properly installed by checking for any fuel leaks.



The operator must use the required equipment during installation.

- The gas train must be connected to the gas connection 1)(Fig. 28), using the flange 2), the gasket 3) and the screws 4) supplied with the burner.
- The train can enter the burner from the right or left side, depending on which is the most convenient, see Fig. 28.
- The gas solenoids must be as close as possible to the burner to ensure that the gas reaches the combustion head within the safety time of 3s.
- Make sure that the pressure governor calibration range (colour of the spring) includes the pressure required by the burner.

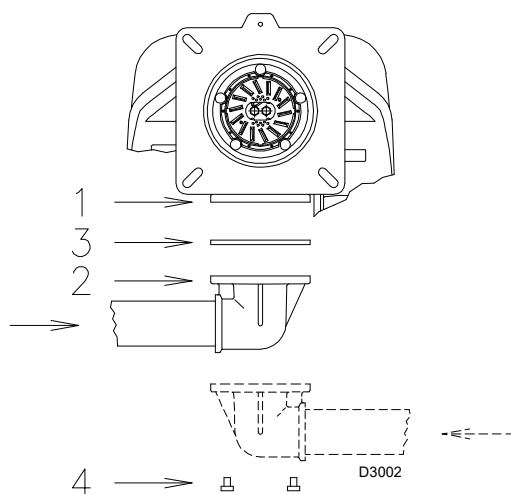

**Fig. 28**

**4.12.4 Gas pressure**

Tab. K indicates the pressure drops of the combustion head and gas butterfly valve depending on the burner operating output.

kW	(mbar)		
	G 20	G 25	G 31
930	5.2	7.8	6.9
1033	6.5	9.8	8.7
1137	8	12	10.6
1240	9.6	14.3	12.7
1343	11.3	16.8	15
1447	13.1	19.5	17.4
1550	15	22.4	20
1653	17	25.4	22.7
1757	19.2	28.7	25.6
1860	21.5	32.1	28.6

**Tab. K**



**Data of head thermal power and gas pressure refer to operation with gas butterfly valve fully open (90°).**

The values shown in Tab. K refer to:

- Natural gas G 20 NCV 9.45 kWh/Sm<sup>3</sup> (8.2 Mcal/Sm<sup>3</sup>)
- Natural gas G 25 NCV 8.13 kWh/Sm<sup>3</sup> (7.0 Mcal/Sm<sup>3</sup>)

The adjacent table shows the minimum pressure drops along the gas supply line depending on the maximum burner output.

Combustion head pressure drop.

Gas pressure measured at test point 1)(Fig. 29), with:

- combustion chamber at 0 mbar;
- combustion head adjusted as in the diagram Fig. 21.

Calculate the approximate maximum output of the burner in this way:

Subtract the combustion chamber pressure from the gas pressure measured at test point 1)(Fig. 29).

Find in Tab. K the pressure value closest to the result of the subtraction.

Read the corresponding output on the left.

### Example with natural gas G20.

Operation at maximum modulating output: 1550 kW

Gas pressure at test point 1)(Fig. 29) = 18.0 mbar

Pressure in combustion chamber = 3.0 mbar

$$18.0 - 3.0 = 15.0 \text{ mbar}$$

A pressure of 15.0 mbar corresponds in Tab. K to an output of 1550 kW.

This value serves as a rough guide; the effective output must be measured at the gas meter.

To calculate the required gas pressure at test point 1)(Fig. 29), set the maximum output required from the burner operation:

Find in Tab. K the output value closest to the desired value.

Read, on the right, the pressure at test point 1)(Fig. 29).

Add this value to the estimated pressure in combustion chamber.

### Example with natural gas G20.

Operation at maximum modulating output: 1550 kW

Gas pressure at test point 1)(Fig. 29) = 15.0 mbar

Pressure in combustion chamber = 3.0 mbar

$$15.0 + 3.0 = 18.0 \text{ mbar}$$

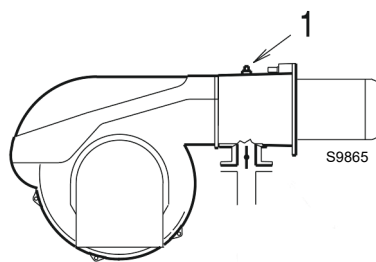

**Fig. 29**

**4.13 Electrical connections**

**Notes on safety for the electrical wiring**



- The electrical wiring must be carried out with the electrical supply disconnected.
- Electrical wiring must be made in accordance with the regulations currently in force in the country of destination and by qualified personnel. Refer to the wiring diagrams.
- The manufacturer declines all responsibility for modifications or connections different from those shown in the wiring diagrams.
- Check that the electrical supply of the burner corresponds to that shown on the identification label and in this manual.
- The burner has been type-approved for intermittent use.  
This means they should compulsorily be stopped at least once every 24 hours to enable the flame control to perform checks of its own start-up efficiency. Normally, burner stopping is guaranteed by the boiler's thermostat/pressure switch.
- If this is not the case, a time switch should be fitted in series to TL to stop the burner at least once every 24 hours. Refer to the wiring diagrams.
- The electrical safety of the device is obtained only when it is correctly connected to an efficient earthing system, made according to current standards. It is necessary to check this fundamental safety requirement. In the event of doubt, have the electrical system checked by qualified personnel. Do not use the gas tubes as an earthing system for electrical devices.
- The electrical system must be suitable for the maximum power absorption of the device, as indicated on the label and in the manual, checking in particular that the section of the cables is suitable for that level of power absorption.
- For the main power supply of the device from the electricity mains:
  - do not use adapters, multiple sockets or extensions;
  - make provisions for an omnipolar switch with a gap between the contacts of at least 3 mm (over-voltage category III), as required by current safety regulations.
- Do not touch the device with wet or damp body parts and/or in bare feet.
- Do not pull the electric cables.

Before carrying out any maintenance, cleaning or checking operations:



Disconnect the electrical supply from the burner by means of the system main switch.



Close the fuel shut-off valve.



Avoid condensate, ice and water leaks from forming.

If the cover is still present, remove it and proceed with the electrical wiring according to the wiring diagrams.

Use flexible cables according to EN 60 335-1 standard.

**4.13.1 Supply cables and external connections passage**

All the cables to be connected to the burner terminal board 6)(Fig. 30) must be threaded through cable grommets, as shown in Fig. 30.

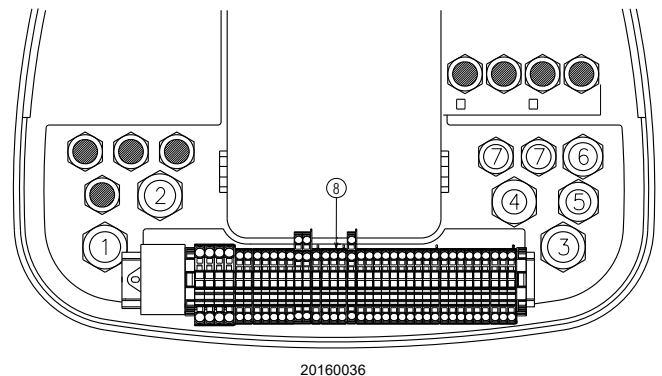

20160036

**Fig. 30**

**Key (Fig. 30)**

- 1 M25 Three-phase power supply
- 2 M20 Single-phase power supply
- 3 M20 TL remote control
- 4 M20 TR remote control
- 5 M20 Gas valves
- 6 M20 Gas pressure switch or valve leak detection control device
- 7 Available



After carrying out maintenance, cleaning or checking operations, reassemble the cover and all the safety and protection devices of the burner.

**5 Start-up, calibration and operation of the burner**

**5.1 Notes on safety for the first start-up**



The first start-up of the burner must be carried out by qualified personnel, as indicated in this manual and in compliance with the standards and regulations of the laws in force.



**Before starting up the burner, refer to section “Safety test - with no gas supply” on page 36.**



Check the correct working of the adjustment, command and safety devices.

**5.2 Servomotor adjustment**

The servomotor provides simultaneous adjustment for the air damper, by means of the adjustable profile cam and the gas butterfly valve.

The servomotor rotates by 130° in 42 s.

Do not alter the factory setting for the 5 cams; just check that they are as specified below:

- Cam I : 130°**  
Limits rotation toward maximum position. When the burner is operating at MAX output, the gas butterfly valve must be fully open: 90°.
- Cam II : 0°**  
Limits rotation toward minimum position. When the burner is shut down, the air damper and gas butterfly valve must be closed: 0°.
- Cam III : 30° (gas)**  
Adjusts the ignition position and the MIN output.
- Cam IV : 30° (oil)**  
Adjusts the ignition position and the output of the 1st stage.
- Cam V : 90°**  
Determines when the 2nd stage light oil valve opens.

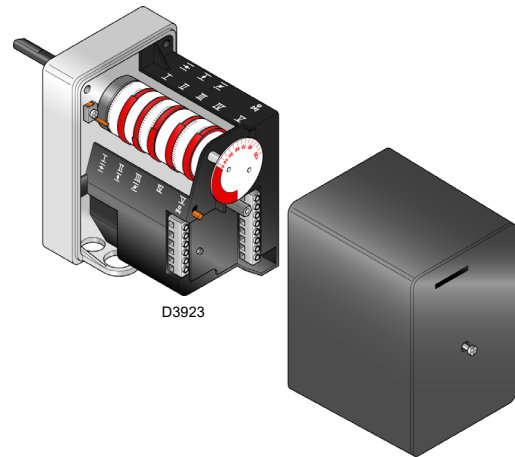

**Fig. 31**

**5.3 Adjustments prior to ignition (light oil)**



It is recommended to adjust first the light oil burner and then the gas burner. Carry out the fuel change with burner off.

The optimum calibration of the burner requires an analysis of the flue gases at the boiler outlet and interventions on the following points.

**1st and 2nd stage nozzles**

See information on page 18.

**Combustion head**

The adjustment of the combustion head already carried out needs not to be altered unless the 2nd stage output of the burner is changed.

**1st and 2nd stage fan damper valve**

See “Servomotor adjustment” on page 28.

## 5.4 Burner start-up (light oil)

Feed electricity to the burner via the disconnecting switch on the boiler panel.

Close the thermostats/pressure switches and turn the switch in Fig. 32 to position "MAN".

As soon as burner starts, check the fan rotation direction through the flame inspection window.



Check that the lamps or testers connected to the solenoid valves, or the pilot lights on the solenoid valves, indicate that no voltage is present. If they indicate the presence of voltage, stop the burner **immediately** and check the electric connections.

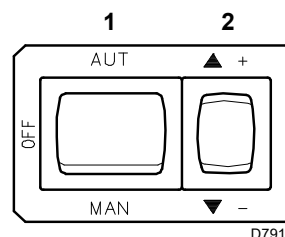

Fig. 32

## 5.5 Burner ignition (light oil)

Turn switch 1)(Fig. 32) to "MAN" position.

During the first firing, during the passage from the 1st to the 2nd stage, there is a momentary lowering of the fuel pressure caused by the filling of the 2nd stage nozzle.

This lowering of the fuel pressure can cause the burner to lockout and can sometimes give rise to pulsations.

Once the following adjustments have been made, the firing of the burner must generate a noise similar to the noise generated during operation.

## 5.6 Burner adjustment (light oil)

It is recommended to adjust first the light oil burner and then the gas burner.



**Carry out the fuel change with burner off.**

### 5.6.1 Ignition

Put the switch 1)(Fig. 32) on "MAN".

During the first firing, during the passage from the 1st to the 2nd stage, there is a momentary lowering of the fuel pressure caused by the filling of the 2nd nozzle tubing. This lowering of the fuel pressure can cause the burner to lockout and can sometimes give rise to pulsations.

When first ignited, the burner should make a noise to show it is operating.

### 5.6.2 Operation

The optimum calibration of the burner requires an analysis of the flue gases at the boiler outlet and interventions on the following points.

- **1st and 2nd stage nozzles**  
See information on page 18.

- **Combustion head**  
The adjustment of the head that has already been carried out as on page 20 does not require any modifications unless the burner output in the 2nd stage is changed.

- **Pump pressure**

12 bar: this is the factory-calibrated pressure, which is usually enough for most applications.

Sometimes, this pressure must be adjusted to:

10 bar: in order to reduce fuel delivery. This adjustment is possible only if the surrounding ambient temperature remains above 0°C.

14 bar: To increase fuel flow rate or ensure the ignition also at temperatures lower than 0°C. To adjust pump pressure use screw 5)(Fig. 20 on page 20).

- **1st and 2nd stage fan damper**  
See servomotor adjustment on page 28.

**5.7 Adjustments prior to ignition (gas)**

Combustion head adjustment is already described on page 20.

In addition, the following adjustments must also be made:

- Slowly open the manual valves situated upstream of the gas train.
- Adjust the minimum gas pressure switch to the start of the scale.
- Adjust the maximum gas pressure switch to the end of the scale.
- Adjust the air pressure switch to the start of the scale.
- Purge the air from the gas line. We recommend using a plastic tube routed outside the building and to purge air until gas is smelt.
- Fit a U-type pressure gauge or a differential pressure gauge (Fig. 33), with socket (+) on the gas pressure of the pipe coupling and (-) in the combustion chamber.

The manometer readings are used to calculate MAX burner output using the Tab. K.

- Connect two lamps or testers to the two gas line solenoid valves to check the exact moment in which voltage is supplied.

This operation is not required if each of the two solenoid valves is equipped with a pilot light that signals voltage passing through.



**CAUTION**

Before starting up the burner, it is good practice to adjust the gas train so that ignition takes place in conditions of maximum safety, i.e. with gas delivery at the minimum.

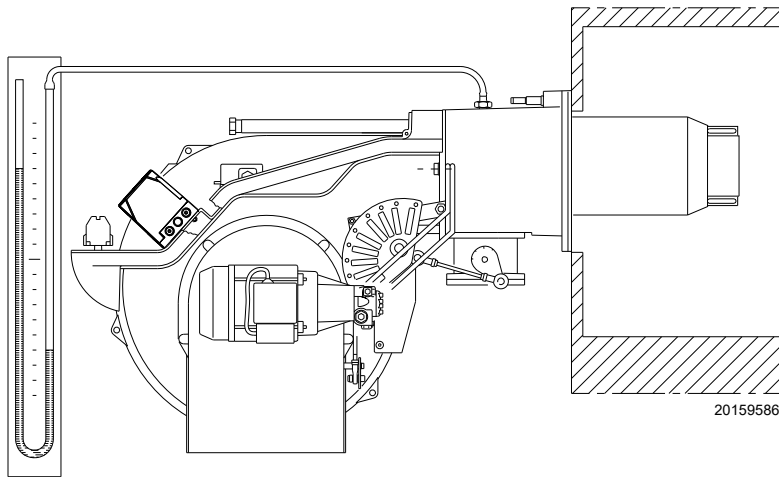

**Fig. 33**

**5.8 Burner start-up (gas)**

Turn off the remote controls and set the switch 1)(Fig. 32 on page 29) to "MAN".

As soon as the burner starts, check the direction of rotation of the fan impeller, looking through the flame inspection window 22)(Fig. 5 on page 10).

Check that the lamps or testers connected to the solenoid valves, or the pilot lights on the solenoid valves, indicate that no voltage is present. If they indicate the presence of voltage, stop the burner immediately and check the electric connections.

## 5.9 Burner adjustment (gas)

The optimum adjustment of the burner requires an analysis of flue gases at the boiler outlet.

Adjust in sequence:

- 1 Ignition output
- 2 Maximum output
- 3 Minimum output
- 4 Intermediate outputs between the two
- 5 Air pressure switch
- 6 Maximum gas pressure switch
- 7 Minimum gas pressure switch

### 5.9.1 Ignition output



ATTENTION

For safety purposes and correct product operation, the ignition output, if it is adjustable, must be carried out by authorized personnel and in compliance with the standards and regulations of the laws in force.

### Air adjustment

The air is adjusted by changing the angle of cam III) (Fig. 31 on page 28) and by using the selector 2)(Fig. 32 on page 29). To adjust the cam of the servomotor, see Fig. 31 on page 28.

### 5.9.2 Maximum output

The MAX output must be set within the firing rate indicated in Fig. 2 on page 9.

In the above instructions we left the burner running at the MIN output.

Now press the "increase output" button 2)(Fig. 32), and keep it pressed until the servomotor has opened the air damper and the gas butterfly valve.

### Adjustment of gas delivery

Measure the gas delivery on the meter.

A rough indication can be obtained from Tab. K on page 25, just read the gas pressure on the "U" pressure gauge (see Fig. 33 on page 30) and follow the indications.

- If delivery needs to be reduced, diminish outlet gas pressure; if it is already very low, slightly close the VR adjustment valve.
- If delivery needs to be increased, increase the adjuster outlet gas pressure.

### Air adjustment

The air is adjusted by varying the angle of cam I) (Fig. 31 on page 28) and by using the selector 2)(Fig. 32 on page 29). To adjust the cam of the servomotor, see Fig. 31 on page 28.

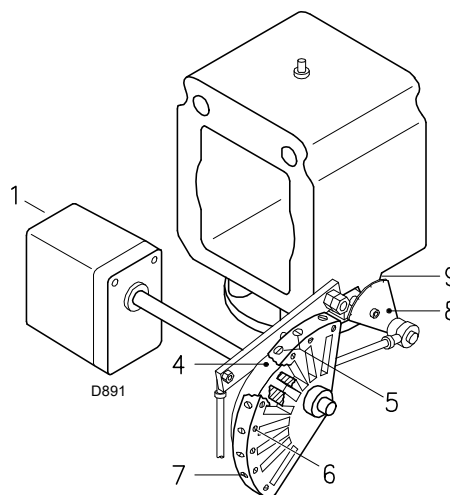

Fig. 34

Key (Fig. 34)

- 1 Servomotor
- 2 Servomotor 1) - cam 4): fastened
- 3 Servomotor 1) - cam 4): unfastened
- 4 Variable profile cam
- 5 Screws for adjusting the adjustable profile
- 6 Screws for fixing adjustment
- 7 Screws for adjusting the end profile
- 8 Gas butterfly valve graduated sector
- 9 Index of graduated sector 8)

**5.9.3 Minimum output**

MIN output must be selected within the firing rate range indicated on Fig. 2 on page 9. Press button 2)(Fig. 35) “Output decrease” and keep it pressed until the servomotor reaches (Fig. 35) the factory adjustment.

**Air adjustment**

Progressively adjust the end profile of the mechanical cam 4)(Fig. 34 on page 31), using the screws 5)(Fig. 34 on page 31). For example, calibrate the minimum output to 800 kW, check the emissions and if necessary increase or decrease the opening of the air damper (“Air adjustment” on page 32).

Bring the output to 800 kW using the screws 5) of the mechanical cam (Fig. 34 on page 31) and check the emissions.

**Adjustment of gas delivery**

The air is adjusted by changing the angle of cam III) of the servomotor (Fig. 35) and by using the selector 2)(Fig. 35). To adjust the cam of the servomotor, see Fig. 35.

**NOTE:**

**The servomotor follows the adjustment of cam III only when the angle of the cam is reduced. If it is necessary to increase the angle of the cam, you must first increase the angle of the servomotor by means of the “output increase” key, then increase the angle of cam III, and finally bring the servomotor to the position of MIN output, with the “Output reduction” key.**

To adjust cam III, see Fig. 35.

**5.9.4 Intermediate outputs**

**Adjustment of gas delivery**

No adjustment is required

**Air adjustment**

After adjusting the maximum and minimum output of the burner, carry out air adjustment on higher intermediate positions of the servomotor.

The passage from one position to the next one is obtained by pressing the button 2) on the symbol (+) or (-) (Fig. 32 on page 29). Press button 2)(Fig. 32 on page 29) “Output increase” briefly so that the servomotor rotates by about 20°, see servomotor graduated index Fig. 35 and air damper graduated index 5)(Fig. 34 on page 31).

Screw or unscrew the screw 5) of the mechanical cam (Fig. 34 on page 31) to increase or decrease the gas output so as to adjust it to the corresponding air output, to obtain optimal combustion.

Proceed in the same way with the other screws.

Switch off the burner using switch 1)(Fig. 32 on page 29), OFF position, release the mechanical cam I) (Fig. 34 on page 31) to separate the gears of the servomotor, pressing and moving downwards button 3)(Fig. 35), then manually rotate the mechanical cam I) (Fig. 35) backwards and forwards a few times to check that the movement is smooth and without any hindrance.



**ATTENTION**

It is recommended that the mechanical cam 5)(Fig. 34 on page 31) be bound again to the servomotor by shifting button 3)(Fig. 35) upwards.

As far as is possible, try not to move those screws at the ends of the mechanical cam that were previously adjusted for the opening of the gas butterfly valve to MAX and MIN output.

**NOTE:**

**Once “MAX - MIN - INTERMEDIATE” outputs have been adjusted, recheck the ignition: its noise must be equal to the one of the following operation. If you notice any sign of pulsations, reduce the ignition stage delivery.**

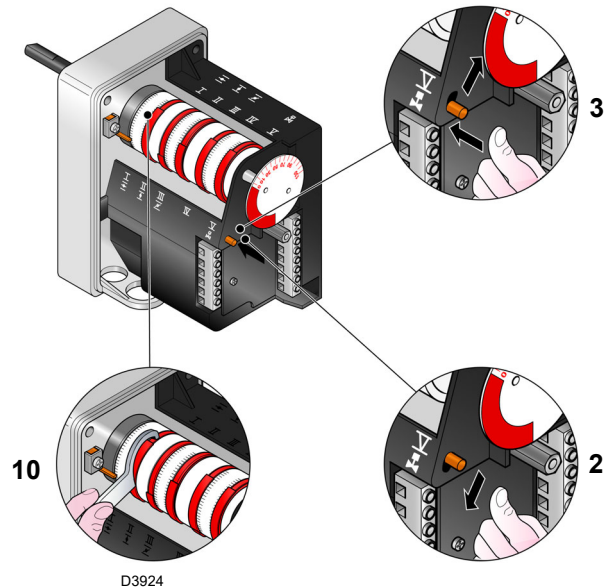

**Fig. 35**



**ATTENTION**

Take care that the cam profile variation is progressive.

**5.10 Pressure switch adjustment**

**5.10.1 Air pressure switch**

Adjust the air pressure switch after performing all other burner adjustments with the air pressure switch set to the start of the scale (Fig. 36). With the burner operating at MIN output, increase adjustment pressure by slowly turning the relevant knob clockwise until the burner locks out.

Then turn the knob anticlockwise by about 20% of the set point and repeat burner start-up to ensure it is correct.

If the burner locks out again, turn the knob slightly anticlockwise.



**ATTENTION**

In conformity with the standard, the air pressure switch must prevent the air pressure falling below 80% of the adjusted value and the CO in the flue gases exceeding 1% (10,000 ppm).

To check this, insert a combustion analyser in the flue, slowly reduce the burner air setting (for example with a piece of cardboard) and verify that the burner locks out before the CO value in the flue gases exceeds 1%.

The incorporated air pressure switch can work in a 'differential' mode if connected with two pipes. If a strong depression in the combustion chamber during the pre-purging phase does not allow the air pressure switch to switch, this can be obtained by applying a second tube between the air pressure switch and the suction inlet of the fan. In this way, the pressure switch will work in differential mode.



**ATTENTION**

The use of the air pressure switch with differential operation is only allowed in industrial applications and where standards enable the air pressure switch to control only fan operation, without any reference to CO limit.



**ATTENTION**

Connecting the air pressure switch in differential mode, the burner will no longer be certified according to the EN 676 standard.

**5.10.2 Maximum gas pressure switch**

Adjust the maximum gas pressure switch (Fig. 37) after making all other burner adjustments with the maximum gas pressure switch set to the end of the scale.

To calibrate the maximum gas pressure switch, open the tap and then connect a pressure gauge to its pressure test point.

The maximum gas pressure switch must be regulated to a value no higher than 30% of the measurement read on the gauge when the burner is working at maximum output. After making the adjustment, remove the pressure gauge and close the tap.

**5.10.3 Minimum gas pressure switch**

The purpose of the minimum gas pressure switch is to prevent the burner from operating in an unsuitable way due to too low gas pressure. Adjust the minimum gas pressure switch (Fig. 38) after having adjusted the burner, the gas valves and the gas train stabiliser. With the burner operating at maximum output:

- install a pressure gauge downstream of the gas train stabiliser (for example at the gas pressure test point on the burner combustion head);
- choke slowly the manual gas cock until the pressure gauge detects a decrease in the pressure read of about 0.1 kPa (1 mbar). In this phase, verify the CO value which must always be less than 100 mg/kWh (93 ppm).
- Increase the adjustment of the gas pressure switch until it intervenes, causing the burner shutdown;
- remove the pressure gauge and close the cock of the gas pressure test point used for the measurement;
- open completely the manual gas cock.



**Fig. 36**

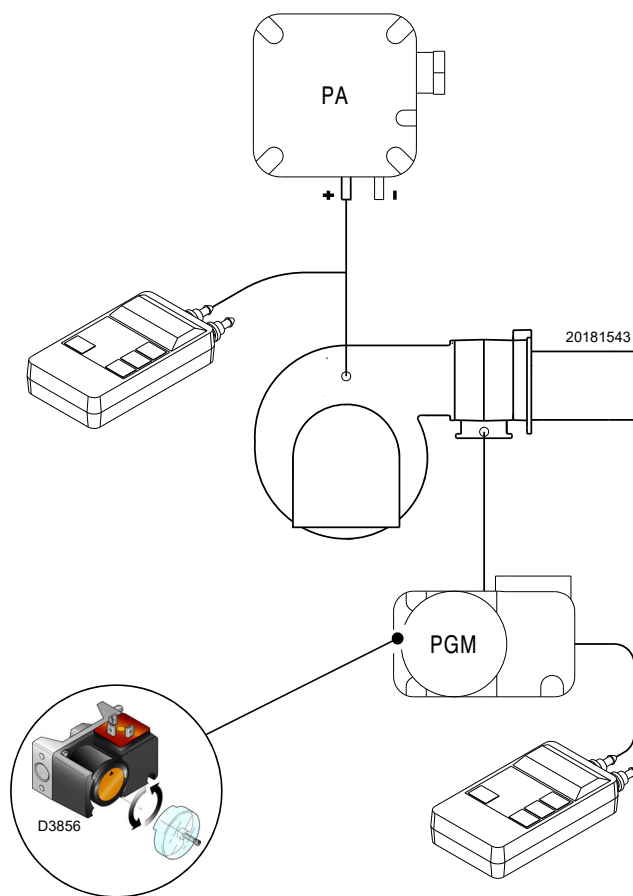

**Fig. 37**

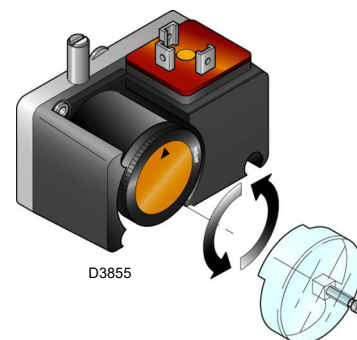

**Fig. 38**









1 kPa = 10 mbar

**ATTENTION**



**5.12 Final checks (with burner operating)**

<ul style="list-style-type: none"> <li>➤ Open the thermostat/pressure switch TL</li> <li>➤ Open the thermostat/pressure switch TS</li> </ul>		The burner must stop
<ul style="list-style-type: none"> <li>➤ Turn the knob of the gas maximum pressure switch to the minimum end of scale position</li> <li>➤ Turn the air pressure switch knob to the maximum end of scale position</li> </ul>		The burner must stop in lockout
<ul style="list-style-type: none"> <li>➤ Turn off the burner and cut off the power</li> <li>➤ Disconnect the minimum gas pressure switch connector</li> </ul>		The burner must not start
<ul style="list-style-type: none"> <li>➤ Disconnect flame detection sensor electrical connections</li> </ul>		The burner must stop in lockout due to ignition failure
<ul style="list-style-type: none"> <li>➤ Obscure the flame sensor</li> </ul>		The burner must stop in lockout due to ignition failure
<ul style="list-style-type: none"> <li>➤ Turn off the burner and cut off the power</li> <li>➤ Disconnect the maximum gas pressure switch connector</li> </ul>		The burner must not start
<ul style="list-style-type: none"> <li>➤ Turn off the burner and cut off the power</li> <li>➤ Disconnect the minimum oil pressure switch connector</li> </ul>		The burner goes into lockout because the oil valves do not open

**Tab. L**



Make sure that the mechanical locking systems on the adjustment devices are fully tightened.

**6 Maintenance**

**6.1 Notes on safety for the maintenance**

The periodic maintenance is essential for the good operation, safety, yield and duration of the burner.

It allows you to reduce consumption and polluting emissions and to keep the product in a reliable state over time.



The maintenance interventions and the calibration of the burner must only be carried out by qualified, authorised personnel, in accordance with the contents of this manual and in compliance with the standards and regulations of current laws.

Before carrying out any maintenance, cleaning or checking operations:



Disconnect the electrical supply from the burner by means of the system main switch.



Close the fuel shut-off valve.



Wait for the components in contact with heat sources to cool down completely.

**6.2 Maintenance programme**

**6.2.1 Maintenance frequency**



The gas combustion system should be checked at least once a year by a representative of the manufacturer or another specialised technician.

**6.2.2 Safety test - with no gas supply**

To perform commissioning in safety conditions, it is very important to check correct wiring between gas valves and burner.

For this purpose, after checking that connections comply with the burner wiring diagrams, it is necessary to carry out a start-up cycle with gas cock closed (dry test).

- 1 The manual gas valve must be closed using the locking/unlocking device ("Lock-out / tag out" procedure).
- 2 Ensure that burner limit electrical contacts are closed
- 3 Ensure that minimum gas pressure switch contact is closed
- 4 Try to start the burner

The start-up cycle must occur according to the following steps:

- Fan motor start-up for pre-purging
- Gas valve leak detection control, if applicable
- Pre-purging completion
- Achievement of the ignition point
- Power supply of the ignition transformer
- Supply of gas valves

As gas is closed, the burner cannot ignite and its flame control will switch to stop or safety lockout condition.

The actual supply of gas valves can be checked by inserting a tester; some valves are equipped with lights (or closing/opening position indicators) that activate as soon as they are powered.



**IF POWER SUPPLY OF GAS VALVES OCCURS IN UNEXPECTED MOMENTS, DO NOT OPEN THE MANUAL VALVE, DISCONNECT POWER SUPPLY, CHECK WIRINGS, CORRECT THE ERRORS AND CARRY OUT THE WHOLE TEST AGAIN.**

**6.2.3 Checking and cleaning**



The operator must use the required equipment during maintenance.

**Combustion**

Carry out an analysis of the combustion flue gases. Significant differences with respect to the previous measurements indicate the points where most care should be exercised during maintenance.

**Combustion head**

Open the burner and make sure that all components of the combustion head are in good condition, not deformed by the high temperatures, free of impurities from the surroundings and correctly positioned.

**Burner**

Check for excess wear or loose screws in the mechanisms controlling the air damper and the gas butterfly valve. Also make sure that the screws securing the electrical leads in the burner terminal block are fully tightened.

Clean the outside of the burner, taking special care with the articulated couplings and the cam 4)(Fig. 34 on page 31).

**Fan**

Check to make sure that no dust has accumulated inside the fan or on its impellers, as this condition will cause a reduction in the air flow rate and provoke polluting combustion.

**Servomotor**

Release cam 4)(Fig. 34 on page 31) from the servomotor, by pressing and shifting button 3)(Fig. 35 on page 32) to the right. Manually rotate it backwards and forwards to make sure it moves smoothly. Now engage the cam again by shifting the button 2)(Fig. 35 on page 32) to the left.

**Boiler**

Clean the boiler as indicated in its accompanying instructions in order to maintain all the original combustion characteristics intact, especially: the flue gas temperature and combustion chamber pressure.

**Flame inspection window**

Clean the glass of the flame inspection window (Fig. 41).

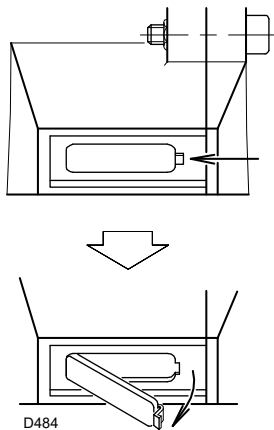

**Fig. 41**

**Electrical current to flame sensor (Fig. 42)**

Clean the glass cover from any dust that may have accumulated. To remove the sensor pull it outwards with force; it is inserted only by pressure.

Min. value for a good work: 70  $\mu$ A.

If the value is lower, it could be due to:

- exhausted sensor;
- low voltage (lower than 187 V);
- bad regulation of the burner.

In order to measure the current, use a microammeter of 100  $\mu$ A d.c., connected in series to the sensor, as in the scheme, with a capacitor of 100  $\mu$ F - 1V d.c. at the same level of the instrument.

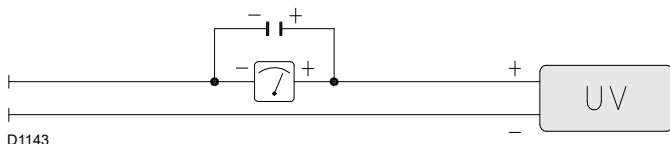

**Fig. 42**

**6.2.4 Safety components**

The safety components must be replaced at the end of their life cycle indicated in Tab. M. The specified life cycles do not refer to the warranty terms indicated in the delivery or payment conditions.

Safety component	Life cycle
Flame control	10 years or 250.000 operation cycles
Flame sensor	10 years or 250.000 operation cycles
Gas valves (solenoid)	10 years or 250.000 operation cycles
Pressure switches	10 years or 250.000 operation cycles
Pressure adjuster	15 years
Servomotor (electronic cam) (if present)	10 years or 250.000 operation cycles
Oil valve (solenoid)(if present)	10 years or 250.000 operation cycles
Oil regulator (if present)	10 years or 250.000 operation cycles
Oil pipes/ couplings (metallic) (if present)	10 years
Fan impeller	10 years or 500.000 start-ups

**Tab. M**

**LIGHT OIL OPERATION**

**Filters (Fig. 43)**

Check the filtering baskets on line 1) and at nozzle 2) present in the system.

Clean or replace if necessary.

If rust or other impurities are observed inside the pump, use a separate pump to lift any water and other impurities that may have deposited on the bottom of the tank.

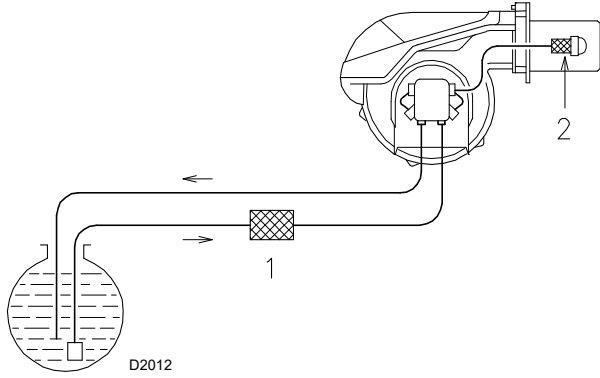

**Fig. 43**

**Pump**

The delivery pressure must comply with Tab. J on page 23.

The depression must be less than 0.45 bar.

Unusual noise must not be evident during pump operation.

If the pressure is unstable, or the pump runs noisily, the flexible hose must be detached from the line filter and the fuel must be sucked from a tank located near the burner. This measure permits the cause of the anomaly to be traced to either the suction piping or the pump.

If the problem lies in the suction line, check the filter is clean and that air is not entering the piping.

**Nozzles**

It is advisable to replace nozzles once a year during periodical maintenance.

Do not clean the nozzle openings.

**Flexible hoses**

Check to make sure that the hoses are still in good condition.

**Fuel tank**

Approximately every 5 years, suck any water on the bottom of the tank using a separate pump.

**Combustion**

If the combustion values measured before starting maintenance do not comply with applicable Standards or do not indicate efficient combustion, consult the table below or contact our Technical Support Service to implement the necessary adjustments.

EN 267	Air excess		
	Max. output $\lambda \leq 1.2$		Min. output $\lambda \leq 1.3$
	CO <sub>2</sub> % Calibration		CO mg/kWh
Theoretical max CO <sub>2</sub> 0 % O <sub>2</sub>	$\lambda = 1.2$	$\lambda = 1.3$	
15.2	12.6	11.5	≤ 100

**GAS OPERATION**

**Gas leaks**

Make sure that there are no gas leaks on the pipe between the gas meter and the burner.

**Gas filter**

Change the gas filter when it is dirty.

**Combustion**

If the combustion values measured before starting maintenance do not comply with applicable Standards or do not indicate efficient combustion, consult the table below or contact our Technical Support Service to implement the necessary adjustments.

EN 676		Air excess		
		Max. output $\lambda \leq 1.2$		Min. output $\lambda \leq 1.3$
GAS	Theoretical max CO <sub>2</sub> 0 % O <sub>2</sub>	Calibration CO <sub>2</sub> %		CO mg/kWh
		$\lambda = 1.2$	$\lambda = 1.3$	
G 20	11.7	9.7	9.0	≤ 100
G 25	11.5	9.5	8.8	≤ 100
G 30	14.0	11.6	10.7	≤ 100
G 31	13.7	11.4	10.5	≤ 100

### 6.3 Opening the burner



Disconnect the electrical supply from the burner by means of the system main switch.



Close the fuel shut-off valve.



Wait for the components in contact with heat sources to cool down completely.

- Loosen the screws 1) and remove the hood 2)(Fig. 44).
- Disconnect the light oil pipes 7)(Fig. 44).
- Disengage the articulated coupling 8) from the graduated sector 9).
- Remove the screws 10) from the two slide bars 4).
- Assemble the two extensions on the sliding bars 4).
- Refit the screws 10) on the extensions.
- Remove the screws 3) and move the burner backwards by about 100 mm on the slide bars 4)(Fig. 44). Disconnect the electrode cables, then completely retract the burner.

At this point it is possible to extract the inner part 5) after having removed the screw 6)(Fig. 44).

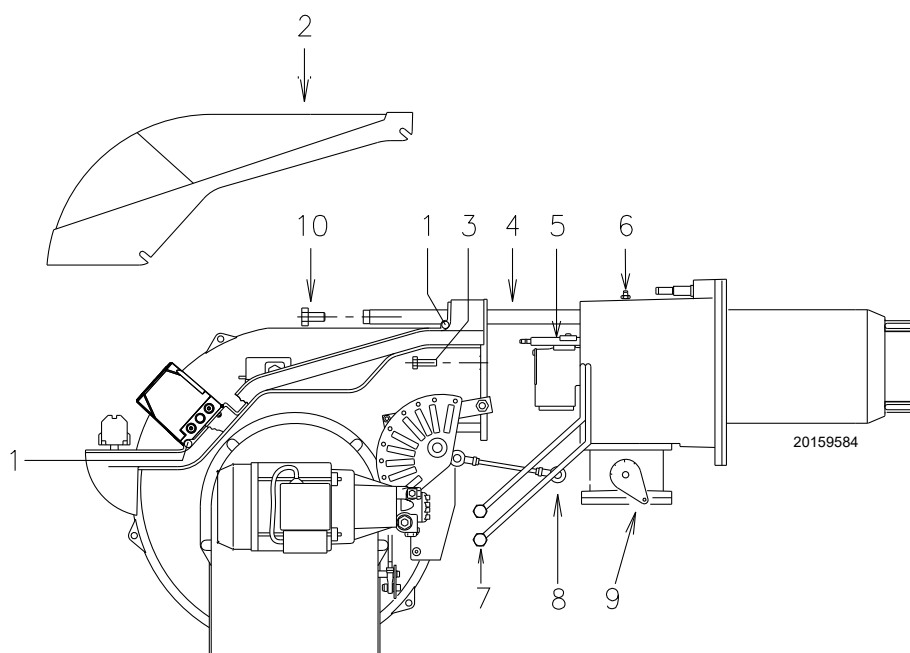

Fig. 44

### 6.4 Closing the burner

Refit following the steps described but in reverse order; refit all burner components as they were originally assembled.



After carrying out maintenance, cleaning or checking operations, reassemble the cover and all the safety and protection devices of the burner.

**7 Faults - Possible causes - Solutions**

The LFL1... flame control is equipped with a lockout indicator (Fig. 45) that turns during the start-up programme, and is visible from the small lockout window.

When the burner does not start or stops, due to a failure, the symbol that appears on the indicator indicates the type of interruption. The positions of the lockout indicator are shown in Fig. 46.

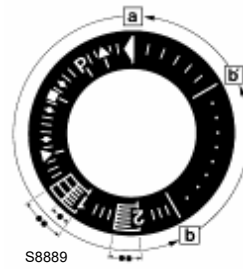

**Lockout indicator**

- a-b Start-up sequence
- b(b') Idle stages (without contact confirmation)
- b(b')-a Post-purging programme

**Fig. 45**

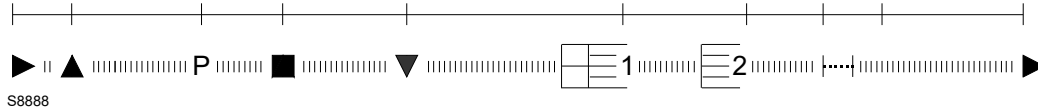

**Fig. 46**

**Fuse replacement**

The fuse 2)(Fig. 47) is in the rear part of the flame control. A spare fuse 1) is also available: it can be extracted after breaking the panel tab A) that houses it. In the event that fuse 2) has been tripped, replace it as shown in Fig. 47.

Find a list of faults, causes and possible solutions for a set of failures that may occur and result in irregular burner operation or no functioning at all.

If a burner malfunction is detected, first of all:

- check that the electrical wiring is adequately connected;
- check whether fuel is delivered;
- check that every adjustment parameter is adequately set.

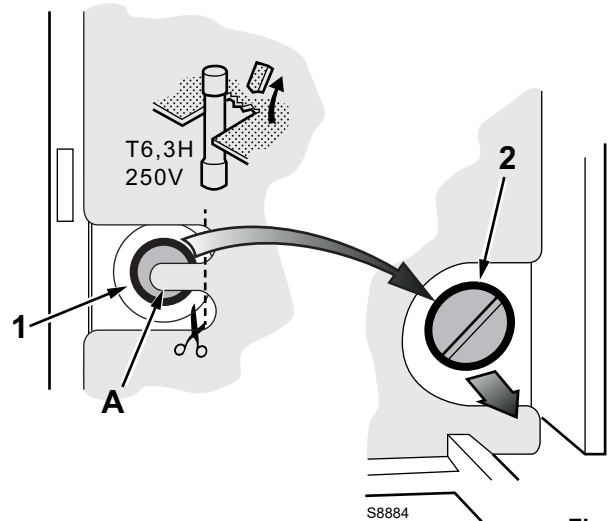

**Fig. 47**



**ATTENTION**

In the event the burner stops, in order to prevent any damage to the installation, do not unblock the burner more than twice in a row. If the burner locks out for a third time, contact the customer service.



**DANGER**

In the event there are further lockouts or faults with the burner, the maintenance interventions must only be carried out by qualified, authorised personnel, in accordance with the contents of this manual and in compliance with the standards and regulations of current laws.

7.1 Light oil operation

Symbol	Problem	Probable cause	Suggested remedy
◀	The burner does not start	Limiter or safety control device open	Adjust or replace
		Flame control lockout	Release
		Fan motor lockout	Release the thermal relay
		No electrical power supply	Close all switches - check connections
		No light oil	Check the light oil supply circuit
		Flame control fuse interrupted	Replace
		Pump is jammed	Replace
		Faulty motor remote control switch	Replace
		Defective flame control	Replace
		Faulty electrical motor	Replace
		Defective safety solenoid valve	Replace
		The burner does not come on and the lockout appears	Flame simulation
Flame sensor short circuit	Replace flame sensor		
Two-phase electrical supply, thermal relay steps in	Reset the thermal relay at return of the three phases		
▲	The burner starts but stops at maximum air damper setting	The servomotor contact does not intervene	Adjust cam or replace servomotor
P	The burner starts and then goes into lockout	Air pressure switch poorly adjusted	Adjust it
		Pressure switch pressure point pipe blocked	Clean
■	The burner starts and then goes into lockout	Failure to the flame detection circuit	Replace flame control
▼	The burner remains in pre-purging phase	The servomotor contact III does not intervene	Adjust cam or replace servomotor
1	Once the pre-purging and the safety time has elapsed the burner goes into lockout without the flame appearing	No fuel in the tank, or water on the bottom	Refill with fuel, or remove the water
		Bad head and damper adjustments	Adjust
		High voltage cable defective or grounded	Replace
		High voltage cable deformed by high temperature	Replace and protect
		Bad electrical wiring on valves or transformer	Check
		Pump unprimed	Prime it
		Pump suction line connected to return line	Correct connection
		Soiled filters (nozzle line)	Clean
		Valves up-line from pump closed	Open them
		Opposite motor rotation	Change electrical wiring to the motor
		Light oil solenoid valves do not open	Check connections and solenoids
		Pilot burner does not work	Check
		Defective flame control	Replace
		Ignition electrode incorrectly adjusted	Adjust it
		Electrode grounded due to broken insulation	Replace
		Motor/pump coupling broken	Replace
		Faulty ignition transformer	Replace
		The flame ignites regularly but the burner goes into lock out at the end of the safety time	Faulty flame sensor or defective flame control
	Dirty flame sensor		Clean
	Smoke in flame (dark Bacharach)	Little air	Adjust the fan head and damper
Incorrect pump pressure		Adjust	
Nozzle filter clogged		Clean or replace	
Boiler room air vents insufficient		Increase	
Dirty or worn nozzle		Replace	
Flame disk soiled, loose or deformed		Clean it, tighten it or replace it	
Smoke in flame (yellow Bacharach)	Too much air	Adjust head and air dampers	

Symbol	Problem	Probable cause	Suggested remedy
	Ignition with pulses or flame failure, delayed ignition	Poorly adjusted head	Adjust
		Incorrectly adjusted fan air damper: too much air	Adjust
		Nozzle not fit for burner or boiler	See nozzle table
		Defective nozzle	Replace
		Unsuitable pump pressure	Adjust
		Ignition electrode not adjusted correctly or soiled	Adjust it
		Output during ignition phase is too high	Reduce
	The burner does not pass to the 2nd stage	Remote control device TR fails to close	Adjust or replace
		Defective flame control	Replace
	Uneven fuel supply	Understand whether the cause lies in the pump or the fuel supply system	Supply fuel to the burner from a tank positioned near the burner itself
	Pump rusty on the inside	Water in the tank	Remove the water with a pump
	Noisy pump, unstable pressure	Air has entered the suction line	Block the couplings
		Depression value too high (higher than 35 cm Hg):	
		Excessive difference of level between burner and tank	Power the burner from a loop circuit
		Piping diameter too small	Increase
		Dirty suction line filters	Clean
		Suction line valves closed	Open them
		The paraffin solidifies due to the low temperature	Put additive in the light oil
	Pump unprimes after prolonged pause	Return pipe not immersed in fuel	Bring it to the same height as the suction line
		Air in the suction line	Block the couplings
	Pump leaks light oil	Loss of sealing organ	Replace the pump
	Dirty combustion head	Dirty nozzle or nozzle filter	Replace
		Unsuitable nozzle delivery or angle	See recommended nozzles
		Loose nozzle	Block it
		Environmental impurities on flame stability disc	Clean
		Incorrect head adjustment, or little air	Adjust it, opening the damper
		Blast tube length not suitable for the boiler	Contact the boiler manufacturer
I	Burner goes into lockout during operation	Flame sensor faulty or dirty	Replace it or clean it
		Air pressure switch faulty	Replace

**Tab. N**

7.2 Gas operation

Symbol	Problem	Probable cause	Suggested remedy
◀	The burner does not start	No electrical power supply	Close all switches and check connections
		A limit or safety thermostat/pressure switch open	Adjust or replace
		Flame control lockout	Release the flame control
		Flame control fuse interrupted	Replace it (2)
		Incorrect electrical wiring	Check
		Defective flame control	Replace
		No gas supply	Open the manual valves between meter and train
		Mains gas pressure insufficient	Contact your GAS COMPANY
		Minimum gas pressure switch fails to close	Adjust or replace
		Air pressure switch in operating position	Adjust or replace
		The servomotor contact does not intervene (closure cam 0°)	Adjust the closure cam 0° or replace the servomotor
	The burner does not come on and the lockout appears	Flame simulation	Replace the flame control
		Faulty motor remote control switch	Replace
		Defective electrical motor	Replace
▲	The burner starts but stops at maximum air damper setting	Motor lockout	Release the thermal relay
		The servomotor contact does not intervene (maximum cam opening)	Cam adjustment (maximum opening) or replace the servomotor
P	The burner starts and then goes into lockout	Air pressure switch does not switch owing to lack of air pressure:	
		Air pressure switch poorly adjusted	Adjust or replace
		Pressure switch pressure point pipe clogged	Clean
		Poorly adjusted head	Adjust
		Dirty fan	Clean
		High depression in the furnace	Contact our Technical Department
■	The burner turns on and then remains in lockout mode	Failure to the flame detection circuit	Replace the flame control
▼	The burner remains in pre-purging phase	The servomotor contact does not intervene (minimum cam)	Cam adjustment (minimum) or replace the servomotor

Symbol	Problem	Probable cause	Suggested remedy
1	Once the pre-purging and the safety time has elapsed the burner goes into lockout without the flame appearing	The GAS solenoid valve lets too little gas through	Increase
		The GAS solenoid valve does not open	Replace the coil or the rectifier panel
		Gas pressure too low	Increase pressure at governor
		Ignition electrode incorrectly adjusted	Adjust it
		Electrode grounded due to broken insulation	Replace
		High voltage cable defective or grounded	Replace
		High voltage cable deformed by high temperature	Replace and protect
		Faulty ignition transformer	Replace
		Incorrect valve or ignition transformer connections	Redo them
		Defective flame control	Replace
		A closed valve upstream the gas train	Open
	Air in pipework	Bleed air	
	Lockout with flame appearing	The GAS solenoid valve lets too little gas through	Increase
		Dirty flame sensor	Check, replace flame sensor
		Faulty connection	Check, replace flame sensor
Insufficient detection current (min.70 $\mu$ A)		Measure current, replace flame sensor	
Flame sensor exhausted, faulty		Replace	
Maximum gas pressure switch intervention		Adjust or replace	
Defective flame control	Replace		
	The burner continues to repeat the start-up cycle without lockout	The gas pressure in the gas mains lies very close to the value to which the gas pressure switch has been set. The sudden drop in pressure after valve opening causes temporary opening of the pressure switch itself, the valve immediately closes and the burner stops. Pressure increases again, the pressure switch closes again and the ignition cycle is repeated. And so on.	Reduce the intervention pressure of the minimum gas pressure switch. Replace the gas filter cartridge
	Lockout without symbol indication	Flame simulation	Replace the flame control
	Burner goes into lockout during operation	Faulty flame sensor	Replace worn parts
		Air pressure switch faulty	Replace
◀	Lockout when the burner stops	Permanent flame in the combustion head or flame simulation	Eliminate permanency of flame or replace the flame control
	Ignition with pulsations	Poorly adjusted head	Adjust
		Ignition electrode incorrectly adjusted	Adjust it
		Incorrectly adjusted fan air damper: too much air	Adjust
		Output during ignition phase is too high	Reduce

Tab. O

## A Appendix - Accessories

### Output regulator kit for modulating gas/two-stage oil operation

With modulating operation, the burner continuously adjusts its output to the heat request, thereby ensuring a great stability of the controlled parameter: temperature or pressure.

The parts to be ordered are two:

- output regulator to be installed to the burner;
- probe to be installed to the heat generator.

Parameter to be controlled		Probe		Output regulator	
	Adjustment field	Type	Code	Type	Code
Temperature	- 100...+ 500°C	PT 100	3010110	RWF50.2	20099869
Pressure	0...2.5 bar	Output probe 4...20 mA	3010213	RWF55.5	20099905
	0...16 bar		3010214		

### Extended head kit

Burner	Standard head length (mm)	Extended head length (mm)	Code
RLS 160/M MX	373	503	3010441

### Soundproofing box kit

Burner	Code	Type	Reduction of noise levels
RLS 160/M MX	3010404	C4/5	10 [dB(A)]

### Spacer kit

Burner	Thickness (mm)	Code
RLS 160/M MX	102	3000722

### Continuous purging kit

Burner	Code
RLS 160/M MX	3010094

### Potentiometer kit

Burner	Code
RLS 160/M MX	3010416

### Clean contacts kit

Burner	Code
RLS 160/M MX	20123294

### Gas trains in compliance with EN 676

Please refer to manual.

### Head kit for boilers with flame inversion

Burner	Code
RLS 160/M MX	3010249

### Differential circuit breaker kit

Burner	Code
RLS 160/M MX	20098337

**B Appendix - Electrical panel layout**

<b>1</b>	<b>Index of layouts</b>
<b>2</b>	Indication of references
<b>3</b>	Functional layout RFGO-A22
<b>4</b>	Functional layout RFGO-A22
<b>5</b>	Functional layout RFGO-A22
<b>6</b>	Electrical wiring that is the responsibility of the installer
<b>7</b>	Functional diagram RWF50...

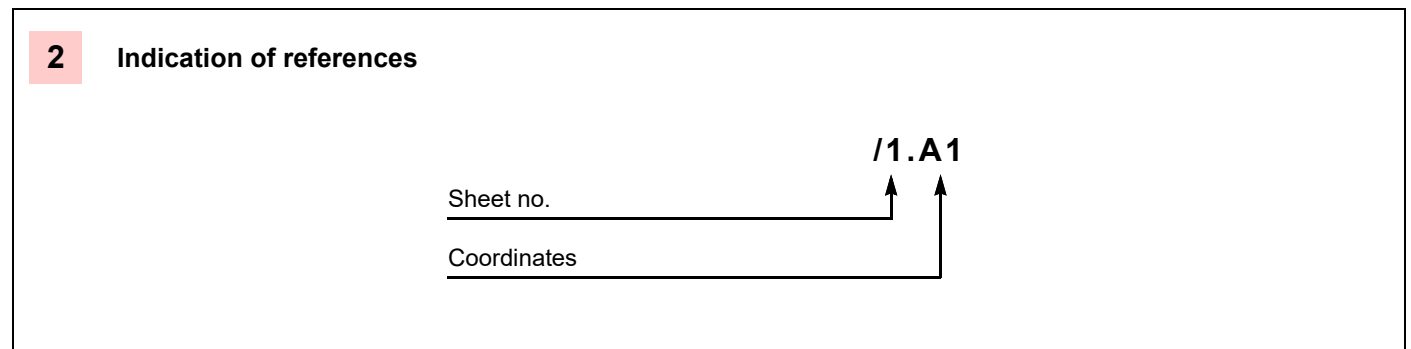



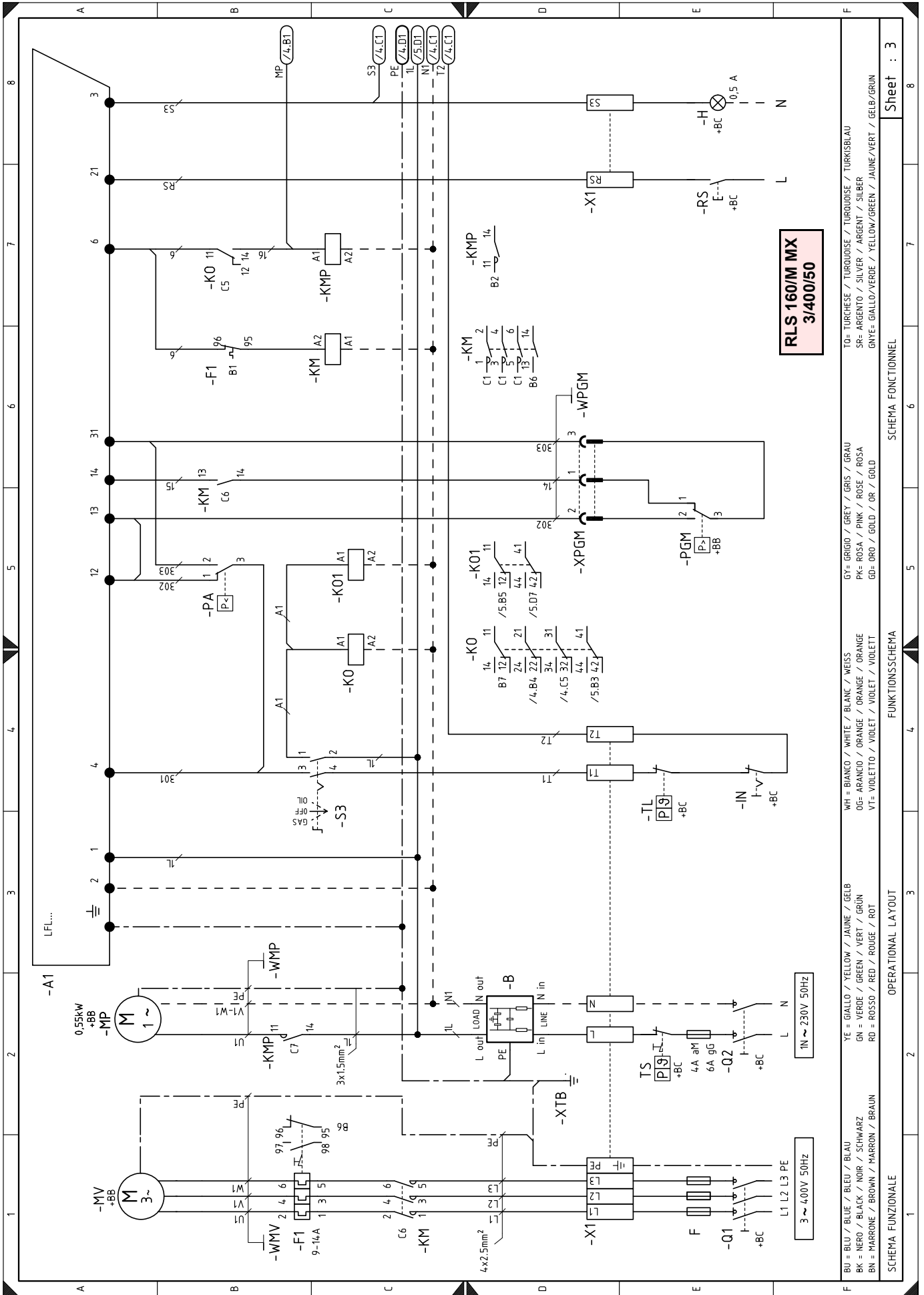

Sheet : 3

SCHEMA FUNZIONALE

FUNKTIONSSCHEMA

OPERATIONAL LAYOUT

SCHEMA FUNZIONALE

BU = BLU / BLUE / BLEU / BLAU  
 BK = NERO / BLACK / NOIR / SCHWARZ  
 BN = MARRONE / BROWN / MARRON / BRAUN  
 YE = GIALLO / YELLOW / JAUNE / GELB  
 GN = VERDE / GREEN / VERT / GRÜN  
 RD = ROSSO / RED / ROUGE / ROT  
 WH = BIANCO / WHITE / BLANC / WEISS  
 OG = ARANCIO / ORANGE / ORANGE / ORANGE  
 VT = VIOLETTA / VIOLET / VIOLET / VIOLETT  
 GY = GRIGIO / GREY / GRIS / GRAU  
 PK = ROSA / PINK / ROSE / ROSA  
 GD = ORO / GOLD / OR / GOLD  
 TO = TURCHESE / TURQUOISE / TURQUOISE / TURKISBLAU  
 SR = ARGENTO / SILVER / ARGENT / SILBER  
 GNYE = GIALLO/VERDE / YELLOW/GREEN / JAUNE/VERT / GELB/GRÜN

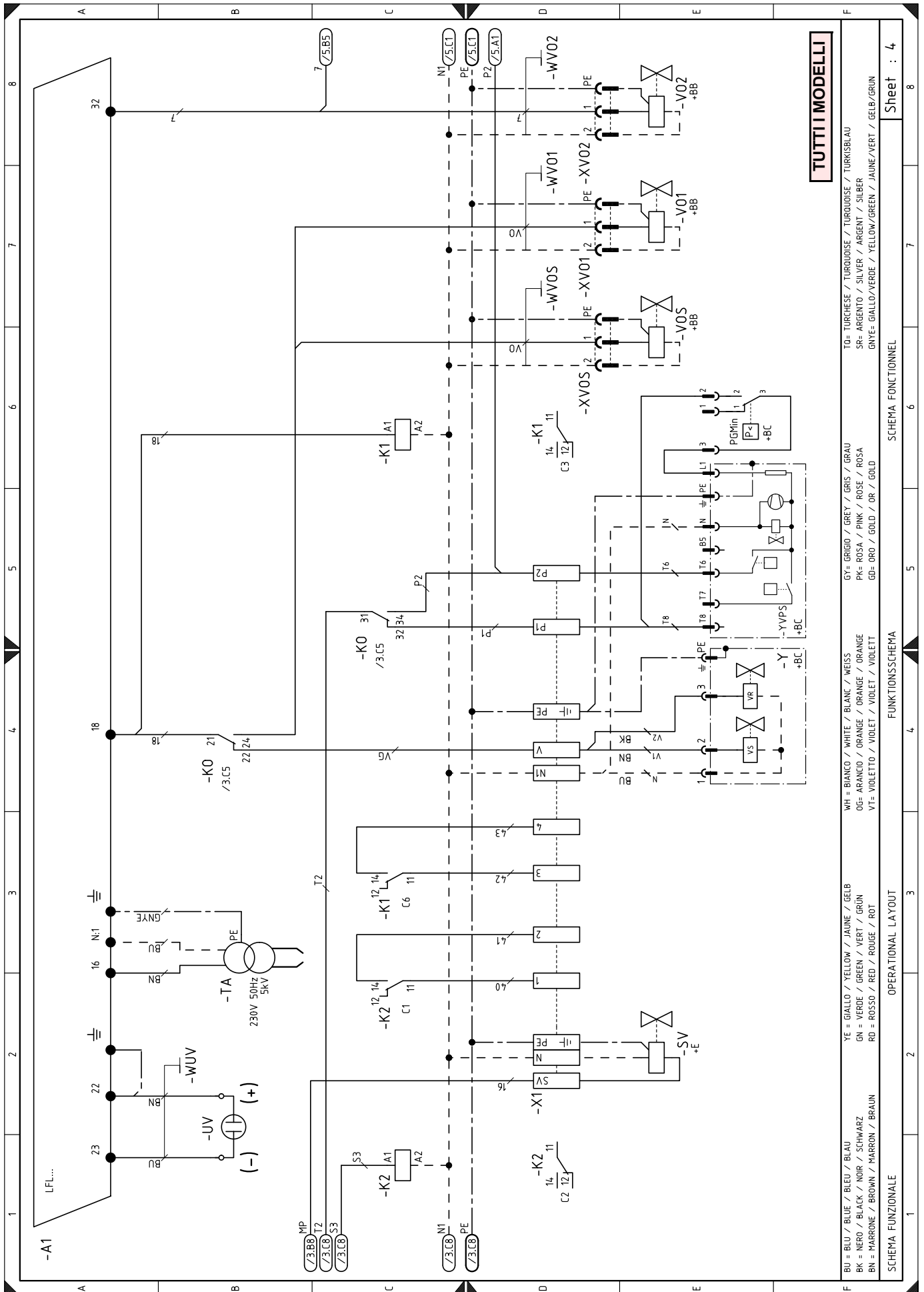

**TUTTI I MODELLI**

TO= TURCHESE / TURQUOISE / TURKOISE / TURKISLAU  
 SR= ARGENTO / SILVER / ARGENT / SILBER  
 GNYE= GIALLO/VERDE / YELLOW/GREEN / JAUNE/VERT / GELB/GRÜN

GY= GRIGIO / GREY / GRIS / GRAU  
 PK= ROSA / PINK / ROSE / ROSA  
 GD= ORO / GOLD / OR / GOLD

WH= BIANCO / WHITE / BLANC / WEISS  
 OG= ARANCIO / ORANGE / ORANGE / ORANGE  
 VT= VIOLETTA / VIOLET / VIOLET / VIOLETT

YE= GIALLO / YELLOW / JAUNE / GELB  
 GN= VERDE / GREEN / VERT / GRÜN  
 RD= ROSSO / RED / ROUGE / ROT

BU= BLU / BLUE / BLEU / BLAU  
 BK= NERO / BLACK / NOIR / SCHWARZ  
 BN= MARRONE / BROWN / MARRON / BRAUN

Sheet : 4

SCHEMA FONCTIONNEL

FUNKTIONSSCHEMA

OPERATIONAL LA YOUT

SCHEMA FUNZIONALE

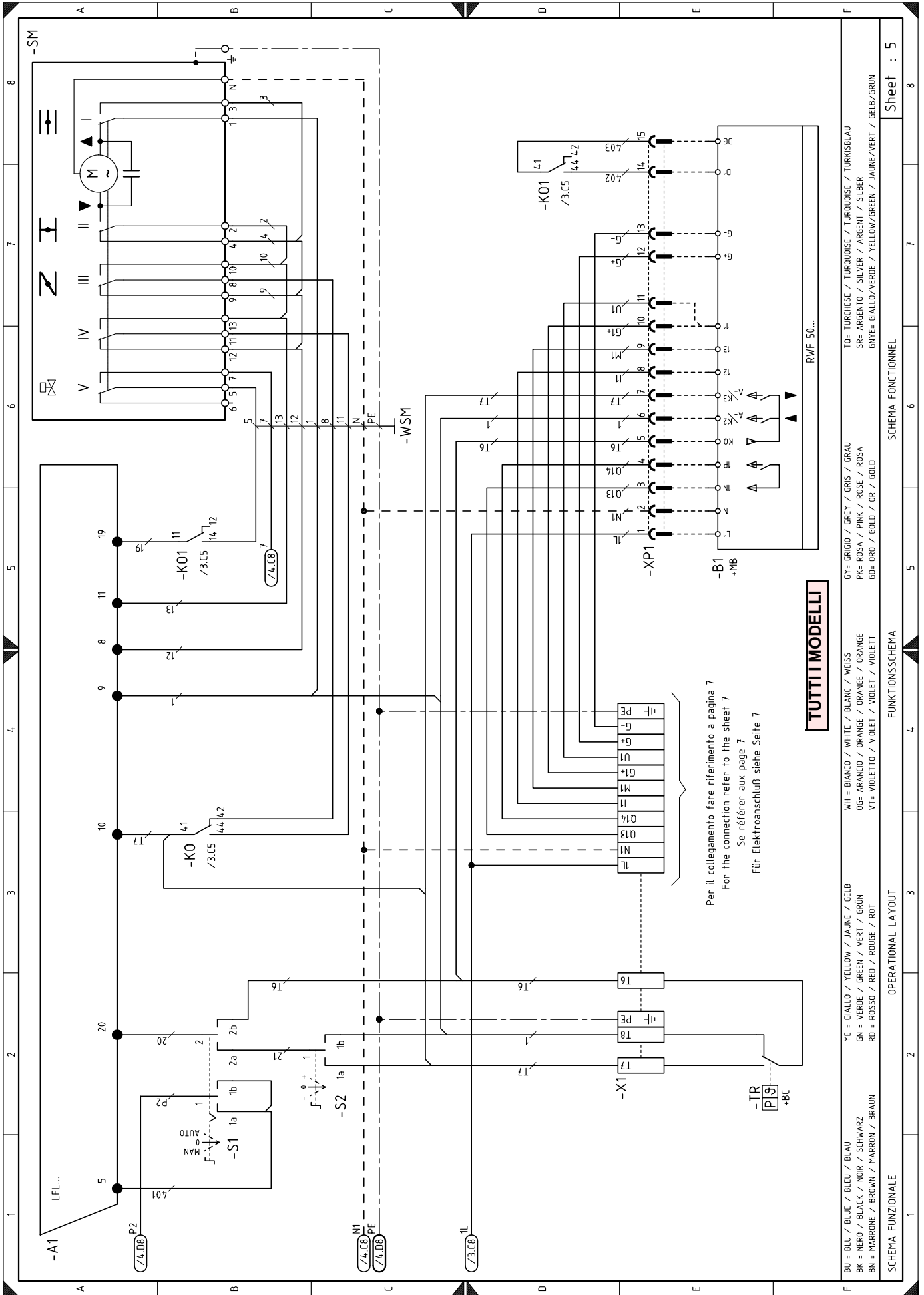

Per il collegamento fare riferimento a pagina 7  
 For the connection refer to the sheet 7  
 Se référer aux page 7  
 Für Elektroanschluss siehe Seite 7

**TUTTI I MODELLI**

BU = BLU / BLUE / BLEU / BLAU	YE = GIALLO / YELLOW / JAUNE / GELB	GY= GRIGIO / GREY / GRIS / GRAU	TO= TURCHESE / TURQUOISE / TURKOISE / TURKISBLAU
BK = NERO / BLACK / NOIR / SCHWARZ	GN = VERDE / GREEN / VERT / GRÜN	PK= ROSA / PINK / ROSE / ROSA	SR= ARGENTO / SILVER / ARGENT / SILBER
BN = MARRONE / BROWN / MARRON / BRAUN	RD = ROSSO / RED / ROUGE / ROT	GD= ORO / GOLD / OR / GOLD	GNVE= GIALLO/VERDE / YELLOW/GREEN / JAUNE/VERT / GELB/GRÜN

SCHEMA FUNZIONALE      SCHEMA FUNCTIONNEL      SCHEMA FUNCTIONNEL

OPERATIONAL LAYOUT      OPERATIONAL LAYOUT      OPERATIONAL LAYOUT

Sheet : 5

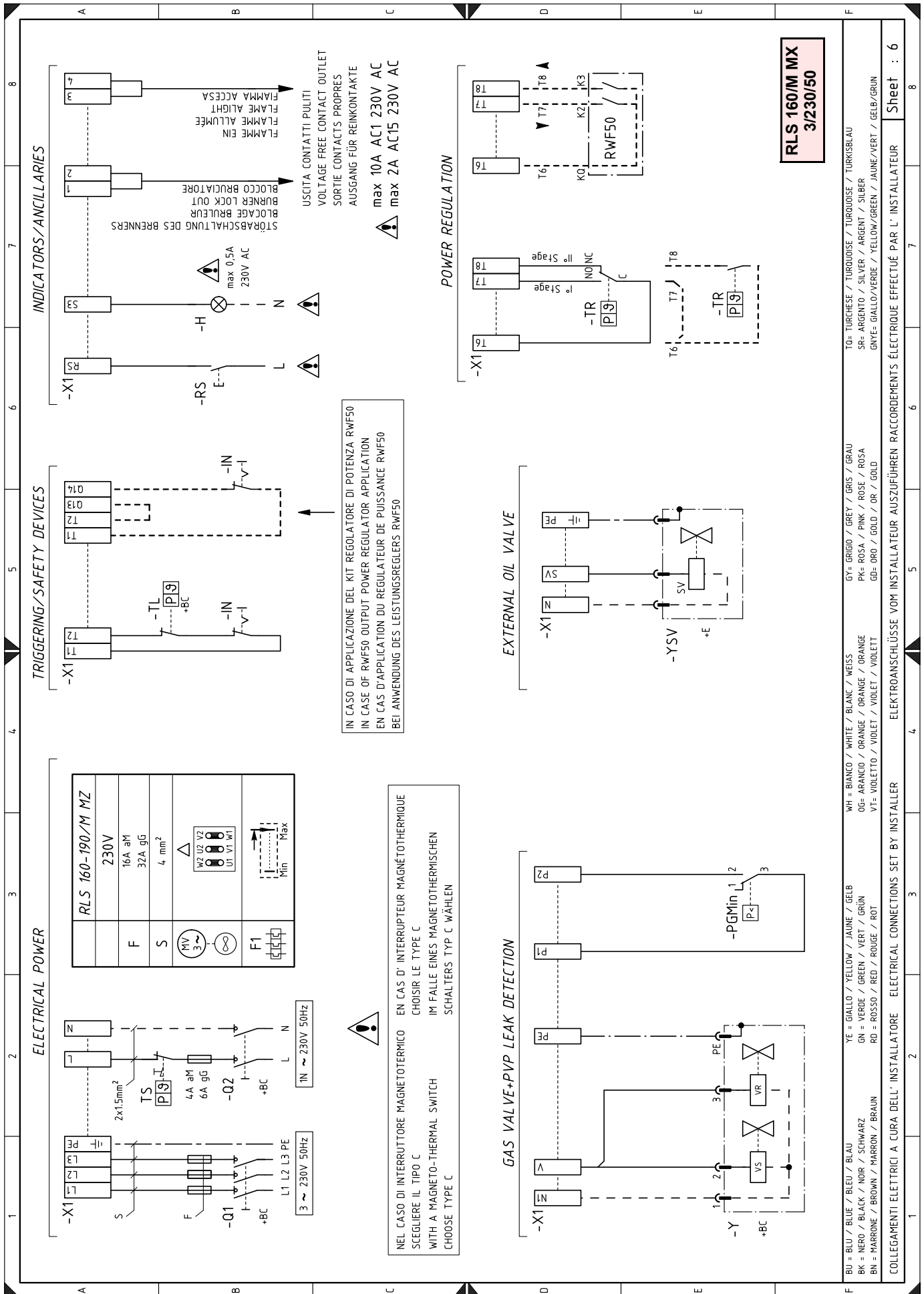





**Wiring layout key**

A1	Electrical flame control	XPGM	Maximum gas pressure switch connector
B	Filter to protect against radio disturbance	XP1	Socket for kit
B1	RWF Output power regulator	XRWF	RWF terminal board
BA	Current input DC 4...20 mA	XTB	Burner earth
BA1	Current input DC 4...20 mA for remote setpoint modification	XVOS	Safety valve connector
BP	Pressure probe	XVO1	Light oil 1st stage valve connector
BP1	Pressure probe	XVO2	Light oil 2nd stage valve connector
BR	Remote setpoint potentiometer		
BT1	Thermocouple probe		
BT2	Probe Pt100, 2 wires		
BT3	Probe Pt100, 3 wires		
BT4	Probe Pt100, 4 wires		
BTEXT	External probe for climatic compensation of the setpoint		
BV	Voltage input DC 0...10 V		
BV1	Voltage input DC 0...10 V for remote setpoint modification		
F	Three-phase line fuses		
F1	Fan motor thermal relay		
H	Remote lockout signal		
IN	Burner manual stop electric switch		
K1	Burner ON dry contact output relay		
K2	Burner lockout dry contact output relay		
KM	Motor contactor		
KMP	Relay		
K0	Relay		
K01	Relay		
MP	Pump motor		
MV	Fan motor		
PA	Air pressure switch		
PGMin	Minimum gas pressure switch		
PGM	Maximum gas pressure switch		
Q1	Three-phase disconnecting switch		
Q2	Single-phase disconnecting switch		
RS	Remote reset button		
S1	Off / automatic / manual selector		
S2	Output increase / decrease selector		
S3	Oil/gas selector switch		
SM	Servomotor		
SV	External light oil valve		
TA	Ignition transformer		
TL	Limit thermostat/pressure switch		
TR	Adjustment thermostat/pressure switch		
TS	Safety thermostat/pressure switch		
UV	Flame sensor		
VOS	Safety valve		
VO1	Light oil 1st stage valve		
VO2	Light oil 2nd stage valve		
Y	Gas adjustment valve + gas safety valve		
YVPS	Gas valve leak detection device		
X1	Main supply terminal board		
XPE	Flame control earth		







---

**RIELLO**

RIELLO S.p.A.  
I-37045 Legnago (VR)  
Tel.: +39.0442.630111  
[http:// www.riello.it](http://www.riello.it)  
[http:// www.riello.com](http://www.riello.com)