

GB **Dual fuel light oil/ gas burners**

Two stage operation

CE

**UK
CA**

EAC

CODE	MODEL	TYPE
20208897	RLS 70	687 T1
20208900	RLS 70	687 T1
20208902	RLS 100	688 T1
20208904	RLS 100	688 T1
20208905	RLS 130	689 T1
20208933	RLS 130	689 T1



Translation of original instructions

1	Information and general warnings.....	3
1.1	Information about the instruction manual	3
1.1.1	Introduction.....	3
1.1.2	General dangers.....	3
1.1.3	Other symbols	3
1.1.4	Delivery of the system and the instruction manual	4
1.2	Guarantee and responsibility.....	4
2	Safety and prevention.....	5
2.1	Introduction.....	5
2.2	Personnel training	5
3	Technical description of the burner	6
3.1	Burner designation	6
3.2	Models available.....	6
3.3	Burner categories - Countries of destination	7
3.4	Technical data	7
3.5	Electrical data.....	7
3.6	Maximum dimensions.....	8
3.7	Burner equipment.....	8
3.8	Firing rates	9
3.9	Test boiler.....	10
3.10	Burner description	11
3.11	Electrical panel description.....	12
3.12	Flame control (LFL...)	13
3.13	Servomotor (SQN73.2C4A20).....	14
4	Installation	15
4.1	Notes on safety for the installation	15
4.2	Handling	15
4.3	Preliminary checks	15
4.4	Operating position	16
4.5	Preparing the boiler	16
4.5.1	Boring the boiler plate	16
4.5.2	Blast tube length.....	16
4.5.3	Securing the burner to the boiler	16
4.6	Access to head internal part.....	17
4.6.1	Combustion head pre-calibration	17
4.7	Electrode positions	17
4.8	Nozzle installation	18
4.8.1	Recommended nozzle.....	18
4.9	Combustion head adjustment.....	19
4.9.1	Adjustments prior to ignition (with light oil)	19
4.10	Light oil supply.....	20
4.10.1	Loop circuit.....	20
4.10.2	Hydraulic connections	21
4.10.3	Hydraulic circuit diagram	21
4.11	Pump	22
4.11.1	Technical data.....	22
4.11.2	Priming pump	22
4.12	Gas supply	23
4.12.1	Gas feeding line (Example) - Please refer to the gas train documentation for more information	23
4.12.2	Gas train.....	24
4.12.3	Gas train installation.....	24
4.12.4	Gas pressure.....	24
4.13	Electrical connections.....	26
4.13.1	Supply cables and external connections passage	26

4.14	Calibration of the thermal relay	27
4.15	Motor rotation	27
5	Start-up, calibration and operation of the burner	28
5.1	Notes on safety for the first start-up	28
5.2	Adjustments prior to ignition (light oil)	28
5.2.1	1st and 2nd stage nozzles	28
5.2.2	Combustion head	28
5.2.3	Pump pressure	28
5.2.4	1st stage fan damper	28
5.2.5	2nd stage fan damper	28
5.3	Burner ignition (light oil)	28
5.4	Adjustments prior to ignition (gas)	29
5.5	Burner start-up (gas)	29
5.6	Burner ignition	29
5.7	Change of fuel	30
5.8	Burner adjustment (gas)	30
5.8.1	Output in 2nd stage	30
5.8.2	Output in 1st stage	30
5.8.3	Ignition output (gas)	30
5.8.4	Operation with LPG - Propane - Butane	30
5.9	Servomotor adjustment	31
5.10	Pressure switch adjustment	32
5.10.1	Air pressure switch - check CO	32
5.10.2	Gas minimum pressure switch	32
5.11	Operation sequence of the burner	33
5.11.1	Burner start-up	33
5.11.2	Ignition failure	33
5.11.3	Burner flame goes out during operation	33
5.11.4	LED PANEL	33
5.12	Final checks (with burner operating)	34
6	Maintenance	35
6.1	Notes on safety for the maintenance	35
6.2	Maintenance programme	35
6.2.1	Maintenance frequency	35
6.2.2	Safety test - with no gas supply	35
6.2.3	Checking and cleaning	35
6.2.4	Combustion control (gas)	37
6.2.5	Safety components	37
6.3	Opening the burner	38
6.4	Closing the burner	38
7	Faults - Possible causes - Solutions	39
7.1	Light oil operation	40
7.2	Gas operation	42
A	Appendix - Accessories	44
B	Appendix - Electrical panel layout	45

1 Information and general warnings

1.1 Information about the instruction manual

1.1.1 Introduction

The instruction manual supplied with the burner:

- is an integral and essential part of the product and must not be separated from it; it must therefore be kept carefully for any necessary consultation and must accompany the burner even if it is transferred to another owner or user, or to another system. If the manual is lost or damaged, another copy must be requested from the Technical Assistance Centre of the area;
- is designed for use by qualified personnel;
- offers important indications and instructions relating to the installation safety, start-up, use and maintenance of the burner.

Symbols used in the manual

In some parts of the manual you will see triangular DANGER signs. Pay great attention to these, as they indicate a situation of potential danger.

1.1.2 General dangers

The **dangers** can be of **3 levels**, as indicated below.



Maximum danger level!
This symbol indicates operations which, if not carried out correctly, cause serious injury, death or long-term health risks.



This symbol indicates operations which, if not carried out correctly, may cause serious injury, death or long-term health risks.



This symbol indicates operations which, if not carried out correctly, may cause damage to the machine and/or injury to people.

1.1.3 Other symbols



DANGER: LIVE COMPONENTS
This symbol indicates operations which, if not carried out correctly, lead to electric shocks with lethal consequences.



DANGER: FLAMMABLE MATERIAL
This symbol indicates the presence of flammable materials.



DANGER: BURNING
This symbol indicates the risks of burns due to high temperatures.



DANGER: CRUSHING OF LIMBS
This symbol indicates the presence of moving parts: danger of crushing of limbs.



WARNING: MOVING PARTS
This symbol indicates that you must keep limbs away from moving mechanical parts; danger of crushing.



DANGER: EXPLOSION

This symbol signals places where an explosive atmosphere may be present. An explosive atmosphere is defined as a mixture - under atmospheric conditions - of air and flammable substances in the form of gases, vapours, mist or dust in which, after ignition has occurred, combustion spreads to the entire unburned mixture.



PERSONAL PROTECTION EQUIPMENT

These symbols indicate the equipment that must be worn and kept by the operator for protection against threats against safety and/or health while at work.



OBLIGATION TO ASSEMBLE THE COVER AND ALL THE SAFETY AND PROTECTION DEVICES

This symbol signals the obligation to reassemble the cover and all the safety and protection devices of the burner after any maintenance, cleaning or checking operations.



ENVIRONMENTAL PROTECTION

This symbol gives indications for the use of the machine with respect for the environment.



IMPORTANT INFORMATION

This symbol indicates important information that you must bear in mind.

- This symbol indicates a list.

Abbreviations used

Ch.	Chapter
Fig.	Figure
Page	Page
Sec.	Section
Tab.	Table

1.1.4 Delivery of the system and the instruction manual

When the system is delivered, it is important that:

- the instruction manual is delivered to the user by the system manufacturer, with the recommendation to keep it in the room where the heat generator is to be installed.
- The instruction manual shows:
 - the serial number of the burner;

.....

- the address and telephone number of the nearest Assistance Centre

.....
.....
.....

- The system supplier must carefully inform the user about:
 - the use of the system;
 - any further tests that may be required before activating the system;
 - maintenance, and the need to have the system checked at least once a year by a representative of the manufacturer or another specialised technician. To ensure a periodic check, the manufacturer recommends the drawing up of a Maintenance Contract.

1.2 Guarantee and responsibility

The manufacturer guarantees its new products from the date of installation, in accordance with the regulations in force and/or the sales contract. At the moment of the first start-up, check that the burner is integral and complete.



ATTENTION

Failure to observe the information given in this manual, operating negligence, incorrect installation and carrying out of non authorised modifications will result in the annulment by the manufacturer of the guarantee that it supplies with the burner.

In particular, the rights to the guarantee and the responsibility will no longer be valid, in the event of damage to things or injury to people, if such damage/injury was due to any of the following causes:

- incorrect installation, start-up, use and maintenance of the burner;
- improper, incorrect or unreasonable use of the burner;
- intervention of unqualified personnel;
- carrying out of unauthorised modifications on the equipment;
- use of the burner with safety devices that are faulty, incorrectly applied and/or not working;
- installation of untested supplementary components on the burner;
- powering of the burner with unsuitable fuels;
- faults in the fuel supply system;
- continuation of use of the burner when a fault has occurred;
- repairs and/or overhauls incorrectly carried out;
- modification of the combustion chamber with inserts that prevent the regular development of the structurally established flame;
- insufficient and inappropriate surveillance and care of those burner components most likely to be subject to wear and tear;
- use of non-original components, including spare parts, kits, accessories and optional;
- force majeure.

The manufacturer furthermore declines any and every responsibility for the failure to observe the contents of this manual.

2 Safety and prevention

2.1 Introduction

The burners have been designed and built in compliance with current regulations and directives, applying the known safety technical rules and envisaging all the potential danger situations. It is necessary, however, to bear in mind that the imprudent and clumsy use of the equipment may lead to situations of death risk for the user or third parties, as well as the damaging of the burner or other items. Inattention, thoughtlessness and excessive confidence often cause accidents; the same applies to tiredness and sleepiness.

It is a good idea to remember the following:

- The burner must only be used as expressly described. Any other use should be considered improper and therefore dangerous.

Specifically:

it can be applied to boilers operating with water, steam, diathermic oil, and to other uses expressly named by the manufacturer;

the type and pressure of the fuel, the voltage and frequency of the electrical power supply, the minimum and maximum deliveries for which the burner has been regulated, the pressurisation of the combustion chamber, the dimensions of the combustion chamber and the ambient temperature must all be within the values indicated in the instruction manual.

- Modification of the burner to alter its performance and destinations is not allowed.
- The burner must be used in exemplary technical safety conditions. Any disturbances that could compromise safety must be quickly eliminated.
- Opening or tampering with the burner components is not allowed, apart from the parts requiring maintenance.
- Only those parts envisaged by the manufacturer can be replaced.



ATTENTION

The manufacturer guarantees safety and proper functioning only if all burner components are intact and positioned correctly.

2.2 Personnel training

The user is the person, body or company that has acquired the machine and intends to use it for the specific purpose. He is responsible for the machine and for the training of the people working around it.

The user:

- undertakes to entrust the machine exclusively to suitably trained and qualified personnel;
- undertakes to inform his personnel in a suitable way about the application and observance of the safety instructions. With that aim, the user undertakes to ensure that everyone knows the use and safety instructions for his own duties;
- Personnel must observe all the danger and caution indications shown on the machine.
- Personnel must not carry out, on their own initiative, operations or interventions that are not within their province.
- Personnel must inform their superiors of every problem or dangerous situation that may arise.
- The assembly of parts of other makes, or any modifications, can alter the characteristics of the machine and hence compromise operating safety. The manufacturer therefore declines any and every responsibility for any damage that may be caused by the use of non-original parts.

In addition:



- must take all the measures necessary to prevent unauthorised people gaining access to the machine;
- the user must inform the manufacturer if faults or malfunctioning of the accident prevention systems are noticed, along with any presumed danger situation;
- personnel must always use the personal protective equipment envisaged by legislation and follow the indications given in this manual.

3 Technical description of the burner

3.1 Burner designation

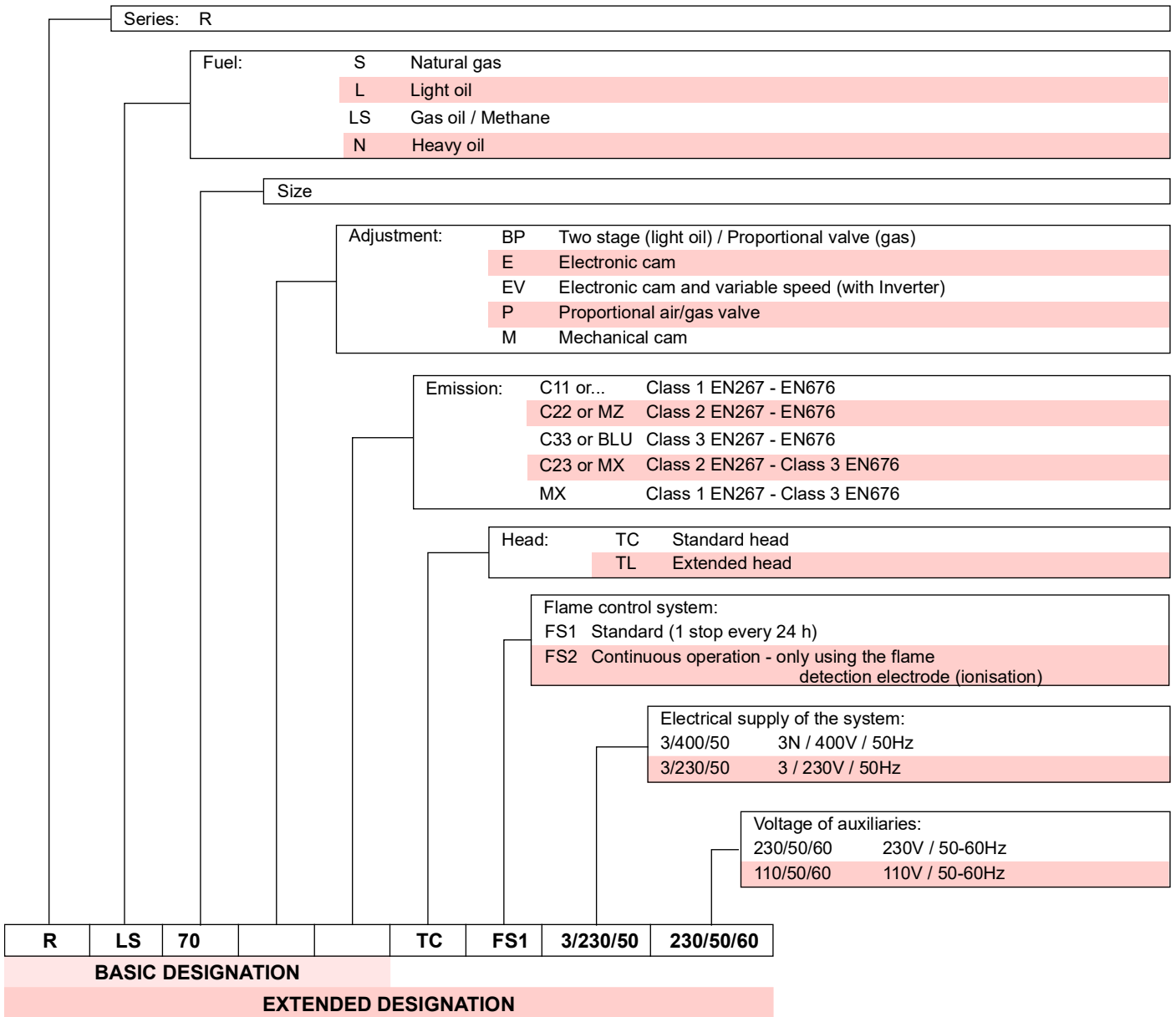

3.2 Models available

Designation		Voltage	Start-up	Code
RLS 70	TC	3/230-400/50	Direct	20208897
RLS 70	TL	3/230-400/50	Direct	20208900
RLS 100	TC	3/230-400/50	Direct	20208902
RLS 100	TL	3/230-400/50	Direct	20208904
RLS 130	TC	3/230-400/50	Direct	20208905
RLS 130	TL	3/230-400/50	Direct	20208933

3.3 Burner categories - Countries of destination

Gas category	Country of destination
I2H	AT, BG, CH, CZ, DK, EE, ES, FI, GB, GR, HU, IE, IS, IT, LT, LV, NO, PT, RO, SE, SI, SK, TR
I2E(R)	BE
I2E	LU, PL
I2ELL	DE
I2EK	NL
I2Er	FR

3.4 Technical data

Model			RLS 70	RLS 100	RLS 130
Type			687 T1	688 T1	689 T1
Power ₍₁₎ Delivery ₍₁₎	min - max	kW kg/h	232/465 ÷ 814 19/39 ÷ 69	349/698 ÷ 1163 29.5/59 ÷ 98	465/930 ÷ 1395 39/78 ÷ 118
Fuels			– Light oil, max. viscosity at 20 °C: 6 mm ² /s (1.5°E - 6 cSt) – Natural gas: G20 (methane) - G25 – LPG - G31 (butane)		
Operation			– FS1 - Intermittent (min. 1 stop in 24 hours) – Two-stage (high and low flame) and one-stage (all - nothing)		
Pump	Output at 12 bar Pressure range Fuel temperature	kg/h bar °C max	220 10 - 20 60		
Nozzles		number	2		
Standard applications			Boilers: water, steam, diathermic oil		
Ambient temperature		°C	0 - 40		
Combustion air temperature		°C max	60		
Noise levels ₍₂₎	Sound pressure	dB(A)	74	77.5	80
	Sound power		85	88.5	91
Weight (including packaging)		kg	75 - 77 ₍₃₎	78 - 80 ₍₃₎	80 - 82 ₍₃₎
CE		No.	CE-0476DQ3601		

Tab. A

(1) Reference conditions: Ambient temperature 20°C - Gas temperature 15°C - Barometric pressure 1013 mbar - Altitude 0 m a.s.l.

(2) Sound pressure measured in manufacturer's combustion laboratory, with burner operating on test boiler and at maximum output. The sound power is measured using the "Free Field" method, required by the EN 15036 standard, and according to an "Accuracy: Category 3" measurement, as described in EN ISO 3746.

(3) Blast tube: short-long

3.5 Electrical data

Model			RLS 70	RLS 100	RLS 130
Main electrical supply			3 ~ 230/400V 50Hz		
Auxiliary circuit electrical supply			1N ~ 230V 50Hz		
Maximum absorbed electric power	Light oil	W Max.	2.3	2.7	3.5
	Gas	W Max.	1.7	2.1	2.9
Protection level			IP 44		

Tab. B

3.6 Maximum dimensions

The dimensions of the burner are given in Fig. 1.

Note that to inspect the combustion head the burner must be moved backward and turned upward.

The maximum dimension of the burner, without casing, when open is given by measurement I.

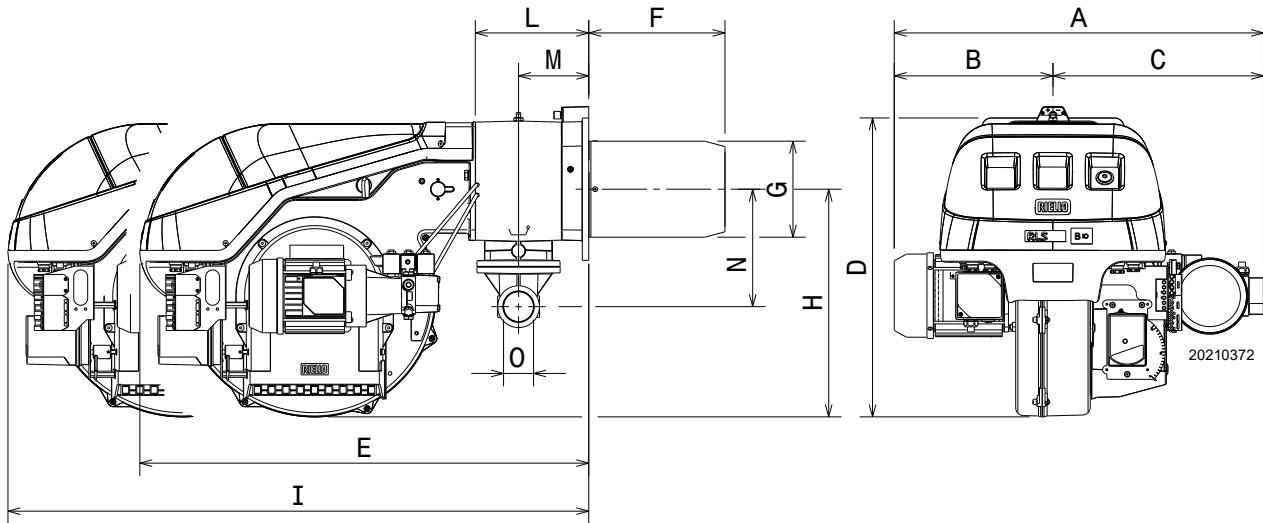

Fig. 1

mm	A	B	C	D	E	F ⁽¹⁾	G	H	I	L	M	N	O
RLS 70	691	296	395	555	840	250-385	179	430	1161	214	134	221	2"
RLS 100	707	312	395	555	840	250-385	189	430	1161	214	134	221	2"
RLS 130	733	338	395	555	840	250-385	189	430	1161	214	134	221	2"

Tab. C

⁽¹⁾ Blast tube: short-long

3.7 Burner equipment

Flange for gas train	No. 1
Seal for flange	No. 1
Flange fixing screws M 10 x 35	No. 4
Thermal flange gasket	No. 1
Screws to fix the burner flange to the boiler: M 12 x 35 ...	No. 4
Flexible hoses	No. 2
Nipples for flexible hoses with gaskets	No. 2
Kit for LPG operation	No. 1
Label for LPG operation	No. 1
Instruction	No. 1
Spare parts list	No. 1



It is recommended to tighten the screws of the gas flange with a tightening torque of **30 Nm ±10%**.

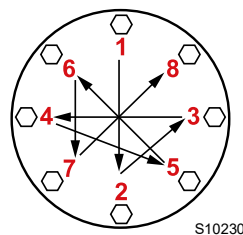

Tighten the nuts gradually (first to 30%, then to 60% up to 100%) according to the cross pattern shown in the figure.

S10230

3.8 Firing rates

The burners RLS 70 - 100 - 130 can work in two ways: one-stage or two-stage.

The **MAXIMUM OUTPUT** is chosen within area A (and B for RLS 130)(Fig. 2). To use also area B (RLS 130), the combustion head has to be pre-calibrated. See "Combustion head pre-calibration" on page 17



The firing rate value (Fig. 2) has been obtained considering an ambient temperature of 20 °C, an atmospheric pressure of 1013 mbar (approx. 0 m a.s.l.), and with the combustion head adjusted as shown on page 19.

The **MINIMUM OUTPUT** must not be lower than the minimum limit of the diagram:

RLS 70 = 232 kW = 19.0 kg/h

RLS 100 = 349 kW = 29.5 kg/h

RLS 130 = 465 kW = 39.0 kg/h

D1194

RLS 70

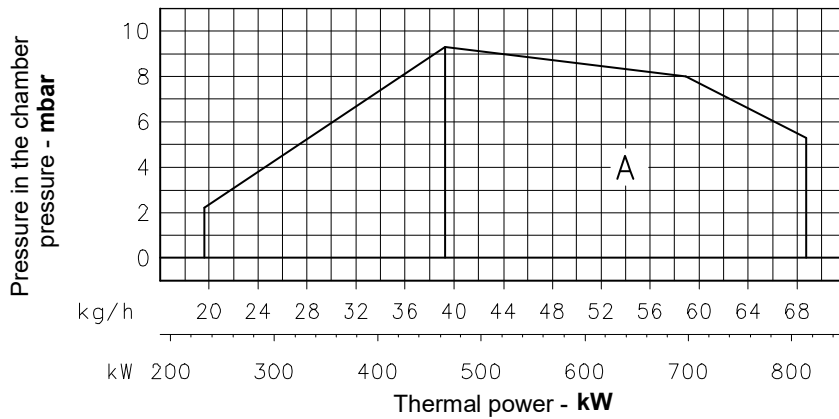

RLS 100

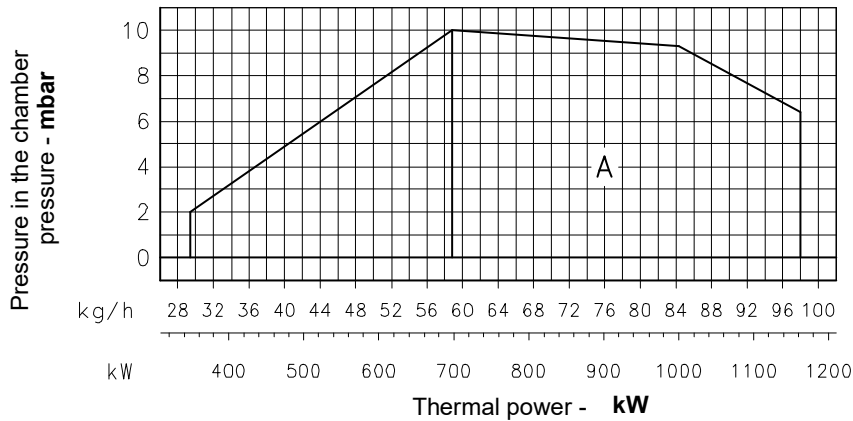

RLS 130

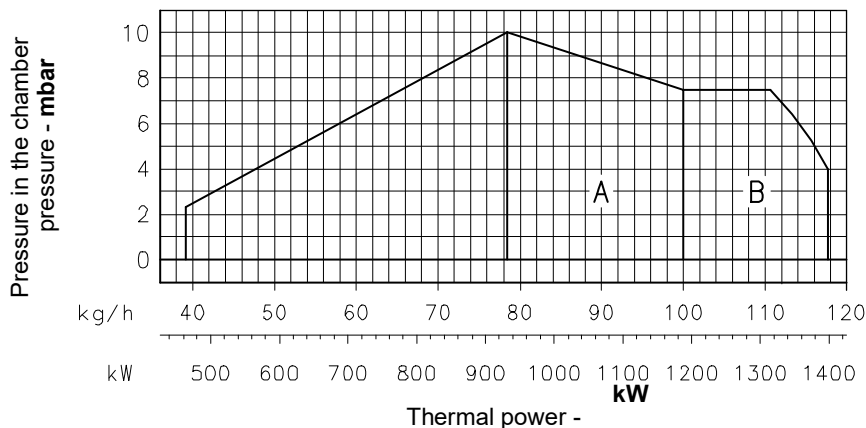

Fig. 2

3.9 Test boiler

The burner/boiler combination does not pose any problems if the boiler is EC approved and its combustion chamber dimensions are similar to those indicated in the diagram (Fig. 3).

If the burner must be combined with a boiler that has not been EC approved and/or its combustion chamber dimensions are clearly smaller than those indicated in the diagram, consult the manufacturer.

The firing rates were obtained in special test boilers, according to EN 676 regulations.

In Fig. 3 you can see the diameter and length of the test combustion chamber.

Example:

Output 650 Mcal/h (407 kW): diameter 60 cm - length 2 m.

MODULATING RATIO

The modulating ratio, obtained in test boilers, according to standard (EN 676 for gas, EN 267 for light oil), is of 4:1 for light oil and 7:1 for gas.

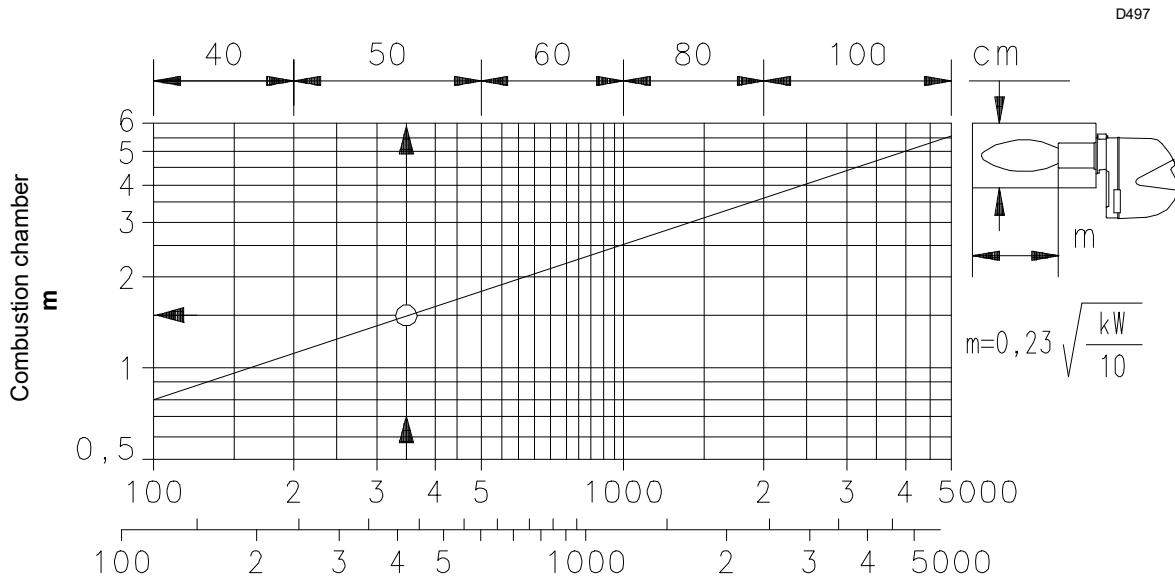

Fig. 3

3.10 Burner description

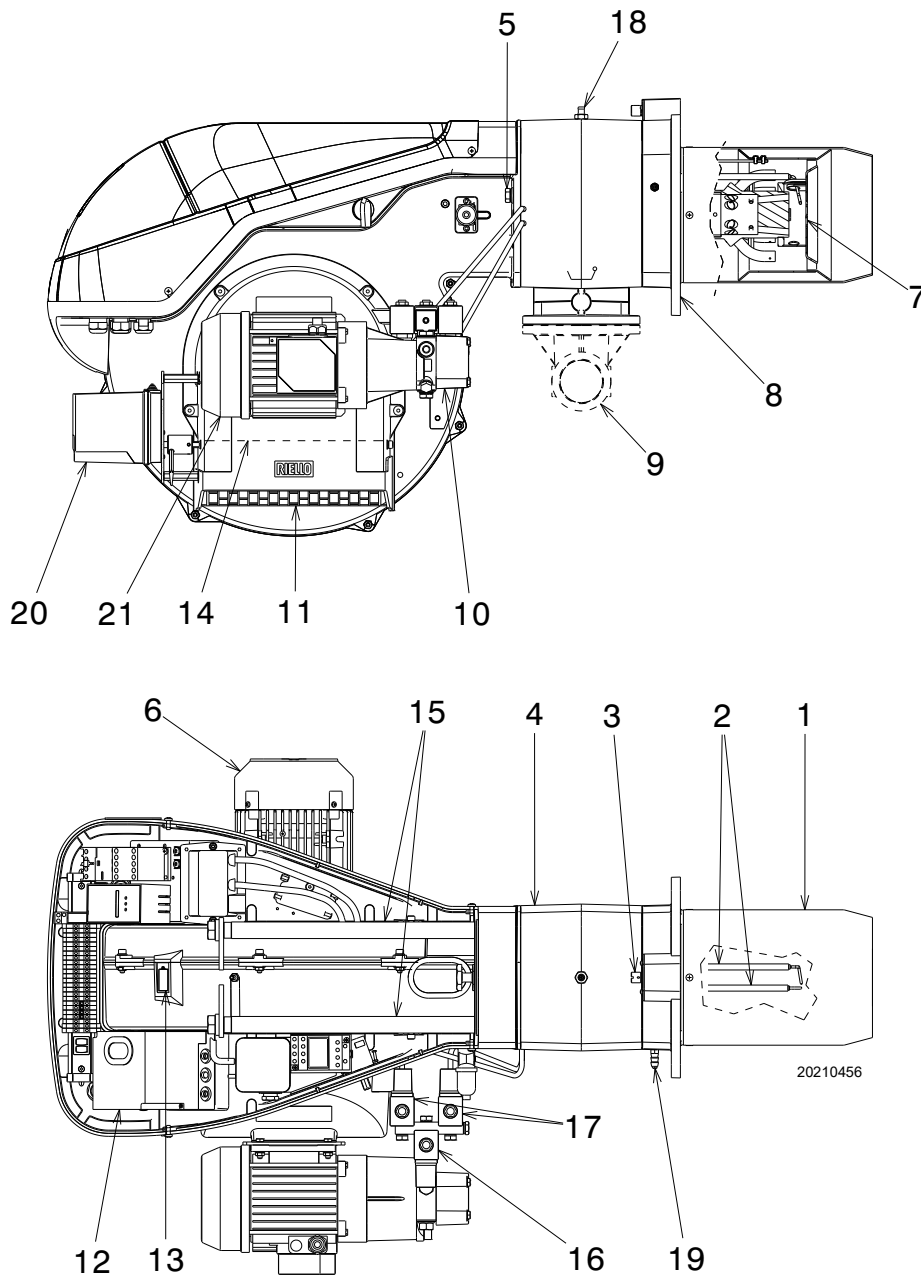

Fig. 4

- | | |
|---|---|
| <ul style="list-style-type: none"> 1 Combustion head 2 Ignition electrodes 3 Screw for combustion head adjustment 4 Pipe coupling 5 Screws to secure fan to pipe coupling 6 Fan motor 7 Flame stability disc 8 Boiler fixing flange 9 Gas input pipe 10 Pump 11 Air inlet to fan 12 Flame control with lockout pilot light and reset button 13 Flame inspection window 14 Air damper 15 Slide bars for opening the burner and inspecting the combustion head 16 Safety valve 17 1st and 2nd stage valves 18 Gas pressure test point and head fixing screw 19 Air pressure test point | <ul style="list-style-type: none"> 20 Servomotor.
When the burner is not operating the air damper is fully closed in order to reduce heat dispersion from the boiler due to the flue draught which draws air from the fan suction inlet. 21 Pump motor <p>Two types of burner lockout may occur:</p> <p>FLAME CONTROL LOCKOUT:
if the flame control 12)(Fig. 4) push-button lights up, it indicates that the burner is in lockout.
Press the push-button to reset.</p> <p>MOTOR LOCKOUT:
release by pressing the push-button on thermal relay.</p> |
|---|---|

3.11 Electrical panel description

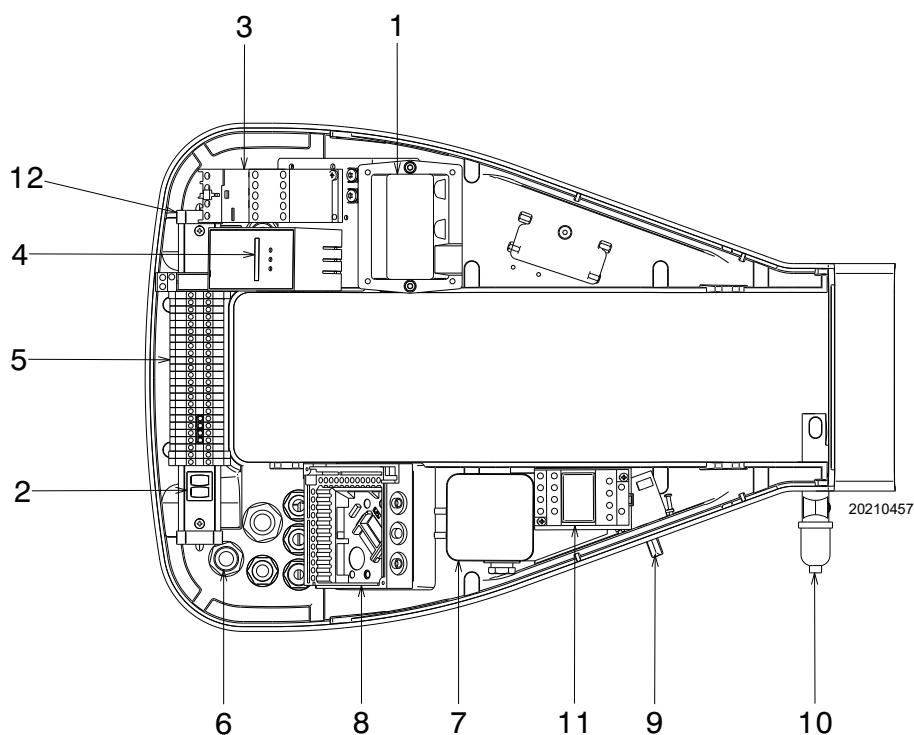

Fig. 5

- 1 Ignition transformer
- 2 Switch for:
ON-OFF operation
Switch for :
1st and 2nd stage
- 3 Motor contactor and thermal relay with reset button
- 4 Led panel
- 5 Terminal board for electrical connection
- 6 Cable-grommets for external connections to be carried out
by the installer
- 7 Air pressure switch (differential type)
- 8 Flame control base
- 9 Oil- gas switch
- 10 Flame sensor
- 11 Relay
- 12 Relay

3.12 Flame control (LFL...)

Important notes



To avoid accidents, material or environmental damage, observe the following instructions!

The flame control LFL1... is a safety device! Avoid opening or modifying it, or forcing its operation. Riello S.p.A. cannot assume any responsibility for damage resulting from unauthorised interventions!

- All interventions (assembly and installation operations, assistance, etc.) must be carried out by qualified personnel.
- Before modifying the wiring in the LFL1... flame control connection area, fully disconnect the system from the power supply (omnipolar separation).
- Protection against electrocution from the flame control and all connected electric components is obtained with the correct assembly.
- Before any intervention (assembly and installation operations, assistance, etc.), ensure the wiring is in order and that the parameters are correctly set, then make the safety checks.
- Falls and collisions can negatively affect the safety functions. In this case, the flame control must not be operated, even if it displays no evident damage.
- **Do not press the reset button or the remote reset button of the flame control for more than 10 seconds because this will damage the internal relay.**

For safety and reliability, comply with the following instructions:

- Avoid conditions that can favour the development of condensate and humidity. Otherwise, before switching on again, make sure that the entire flame control is perfectly dry!
- Static charges must be avoided since they can damage the flame control's electronic components when touched.

Use

The LFL1... flame control is a control and supervision system of medium and large capacity forced draft burners for intermittent operation (at least one controlled shutdown every 24 hours).

Installation notes

- Check the electrical wiring inside the boiler complies with the national and local safety regulations.
- Do not confuse the powered conductors with the neutral ones.
- Ensure that spliced wires cannot get into contact with neighbouring terminals. Use adequate ferrules.
- Arrange the H.V. ignition cables separately, as far as possible from the flame control and the other cables.
- When wiring the unit, make sure that AC 230 V mains voltage cables are run strictly separate from extra low-voltage cables to avoid risks of electrical shock hazard.

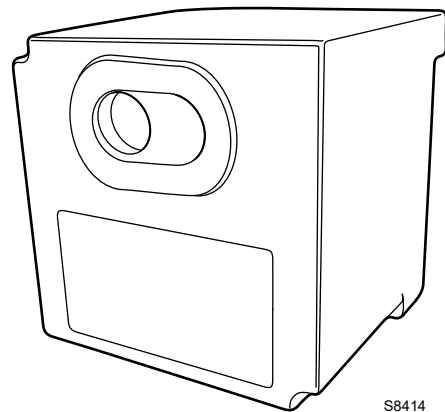

Fig. 6

Electrical wiring of the flame detector

It is important for signal transmission to be almost totally free of any disturbances or loss:

- Always separate the detector cables from the other cables:
 - The capacitive reactance of the line reduces the size of the flame signal.
 - Use a separate cable.
- Respect the allowed cable lengths.
- The ionisation probe is not protected against the risk of electrocution. When connected to the electricity supply, the ionisation probe must be protected against any accidental contact.
- Position the ignition electrode and the ionisation probe so that the ignition spark cannot form an arc on the probe (risk of electric overcharge).

Technical data

Mains voltage	AC 230 V -15 % / +10 %
Mains frequency	50 / 60 Hz ±6 %
Fuse (Internal)	T6.3H250V
Primary fuse (external)	max. 10 A
Weight	approx. 1 kg
Power absorption	approx. AC 3.5 VA
Protection level	IP40
Safety class	II
Input current at terminal 1	max. 5 A continuous (peaks of 20 A / 20 ms)
Load on the control terminals	max. 4 A continuous (peaks of 20 A / 20 ms)
Environmental conditions	
Operation	DIN EN 60721-3-1
Climatic conditions	Class 1K3
Mechanical conditions	Class 1M2
Temperature range	-20...+60°C
Humidity	< 95% RH

Tab. D

3.13 Servomotor (SQN73.2C4A20)

Warnings



To avoid accidents, material or environmental damage, observe the following instructions!

Avoid opening, modifying or forcing the actuators.

- All interventions (assembly and installation operations, assistance, etc.) must be carried out by qualified personnel.
- Before modifying the wiring in the connection area of the servomotor, fully disconnect the burner control device from the power supply (omnipolar separation).
- To avoid the risk of electrocution, protect the connection terminals in a suitable manner and correctly fix the cover.
- Check the wiring is in order.
- Falls and collisions can negatively affect the safety functions. In this case, the servomotor must not be operated, even if it displays no evident damage.

Assembly notes

- Check the relevant national safety standards are respected.
- When assembling the servomotor and connecting the damper, the gears can be disengaged by means of a lever, allowing the drive shaft to be easily adjusted in both directions of rotation.



Fig. 7

Technical data

Operating voltage	AC 230 V -15% / +10%
Mains frequency	50/60 Hz ±6%
Energy consumption	6 VA
Angular positioning	Max. 160°, extension of the scale 0-130 °
Assembly position	Any
Protection level	IP 54, in accordance with DIN 40050
Switching voltage	24...250V AC
Type of motor	Synchronous
Environmental conditions	
Storage	
Climatic conditions	DIN EN 60721-3-1
Mechanical conditions	Class 1K3
Temperature range	Class 1M2
Humidity	-20...+60°C < 95% RH
Connection of the cable	Two grafting seats for the connection terminals Type CUM / Stelvio manufacturer for connector: - type CUF 5-4 (grafting seat X1) - type CUF 5-5 (grafting seat X2) Recommended section for cable braided min. 0.5 mm ² and max. 1.5mm ² .

Tab. E

4 Installation

4.1 Notes on safety for the installation

After carefully cleaning all around the area where the burner is to be installed, and arranging for the environment to be illuminated correctly, proceed with the installation operations.



All the installation, maintenance and disassembly operations must be carried out with the electricity supply disconnected.



The installation of the burner must be carried out by qualified personnel, as indicated in this manual and in compliance with the standards and regulations of the laws in force.



The combustion air inside the boiler must be free from hazardous mixes (e.g.: chloride, fluoride, halogen); if present, it is highly recommended to carry out cleaning and maintenance more frequently.

4.2 Handling

The burner packaging includes a wooden platform, it is therefore possible to handle the burner (still packaged) with a pallet truck or fork lift truck.



Burner handling operations can be highly dangerous if not carried out with the greatest attention: distance unauthorised personnel, check integrity and suitability of the means available. Check also that the area in which you are working is empty and that there is an adequate escape area (i.e. a free, safe area to which you can quickly move if the burner should fall). When handling, keep the load at not more than 20-25cm from the ground.



After positioning the burner near the installation point, correctly dispose of all residual packaging, separating the various types of material.



Before proceeding with the installation operations, carefully clean all around the area where the burner will be installed.

4.3 Preliminary checks

Checking the consignment



After removing all the packaging, check the integrity of the contents. In the event of doubt, do not use the burner; contact the supplier.



The packaging elements (wooden cage or cardboard box, nails, clips, plastic bags, etc.) must not be abandoned as they are potential sources of danger and pollution; they should be collected and disposed of in the appropriate places.

		A		B	
		D		C	
		E		F	
GAS-KAASU	<input checked="" type="checkbox"/> FAM.2	G		H	
GAZ-AEPIO	<input type="checkbox"/> FAM.3	G		H	
		I		I	
		L			
				CE	
					

20206732

Fig. 8

Checking the characteristics of the burner

Check the identification label of the burner, showing:

- the model (A)(Fig. 8) and type of burner (B);
- the year of manufacture, in cryptographic form (C);
- the serial number (D);
- the data for electrical supply and the protection level (E);
- the absorbed electrical power (F);
- the types of gas used and the relative supply pressures (G);
- the data of the burner's minimum and maximum output possibilities (H) (see Firing rate). **Warning.** The burner output must be within the boiler's firing rate.
- the category of the appliance/countries of destination (I).
- light oil maximum viscosity (L).



A burner label that has been tampered with, removed or is missing, along with anything else that prevents the definite identification of the burner makes any installation or maintenance work difficult.

4.4 Operating position



- The burner is set up to operate only in positions 1, 2, 3 and 4 (Fig. 9).
- Installation 1 is preferable, as it is the only one that allows the maintenance operations as described in this manual.
- Installations 2, 3 and 4 permit operation but make maintenance and inspection of the combustion head more difficult.



- Any other position could compromise the correct operation of the appliance.
- Installation 5 are forbidden for safety reasons.

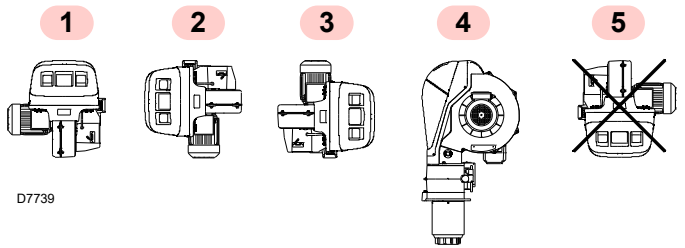

Fig. 9

4.5 Preparing the boiler

4.5.1 Boring the boiler plate

Pierce the closing plate of the combustion chamber, as in Fig. 10. The position of the threaded holes can be marked using the thermal insulation screen supplied with the burner.

mm	A	B	C
RLS 70	185	275 - 325	M 12
RLS 100	195	275 - 325	M 12
RLS 130	195	275 - 325	M 12

Tab. F

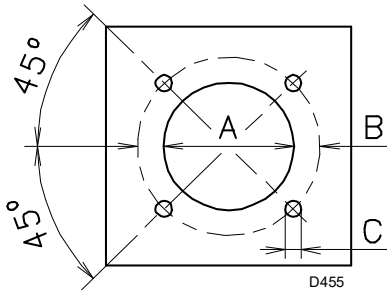

Fig. 10

4.5.2 Blast tube length

The length of the blast tube must be selected according to the indications provided by the manufacturer of the boiler, and in any case it must be greater than the thickness of the boiler door complete with its fettling. The range of lengths available, L (mm), is as follows:

mm	RLS 70	RLS 100	RLS 130
Standard	250	250	250
Extended	385	385	385

Tab. G

For boilers with front flue passes 13) or flame inversion chambers, a protection in heat-resistant material 11) must be inserted between the boiler fettling 12) and the blast tube 10). This protection must not compromise the extraction of the blast tube.

4.5.3 Securing the burner to the boiler



Provide an adequate lifting system.

Separate the combustion head from the rest of the burner (Fig. 11):

- disconnect the light oil pipes unscrewing the two unions 6);
- loosen the 4 screws 3) and remove the cover 1);
- remove screws 2) from the two slide bars 5);
- remove the two screws 4) and pull the burner back on slide bars 5) by about 100 mm;
- disconnect the electrode cables, then completely unthread the burner from the slide bars.

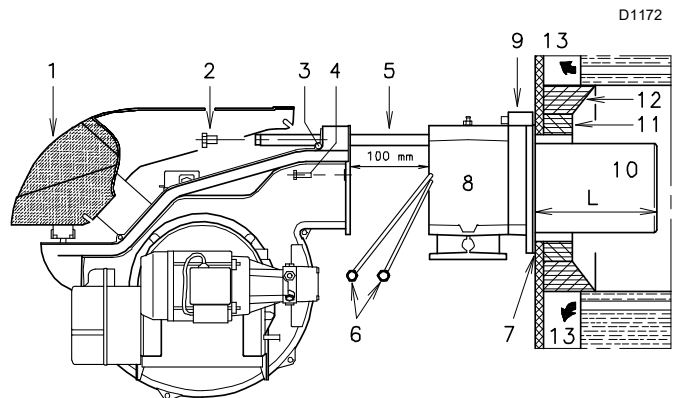

Fig. 11



The seal between burner and boiler must be airtight.

4.6 Access to head internal part

In order to reach inside the combustion head (Fig. 12) proceed as follows:

- remove the screw 1) and the internal part 2).



Be careful as some drops of fuel may leak out during this phase.

4.6.1 Combustion head pre-calibration

For the **RLS 130** model, check, at this point, whether the maximum output of the burner in the 2nd stage is within area **A** or in area **B** of the firing rate. See "Firing rates" on page 9.

- If it is in area A, no intervention is required.
- However, if it is in area B:
 - Loosen the screws 1)(Fig. 13) and disassemble the blast tube 2).
 - Move the rod 3)(Fig. 13) from position A to position B, thereby drawing back the shutter 4).
 - Reassemble the blast tube 2)(Fig. 13) and the screws 1).

Once this operation (if necessary) has been carried out, fix the flange 9)(Fig. 11 on page 16) to the boiler plate, interposing the insulating gasket 7)(Fig. 11 on page 16) supplied. Use the 4 screws, also supplied with the unit, after protecting the thread with anti-seizing product.

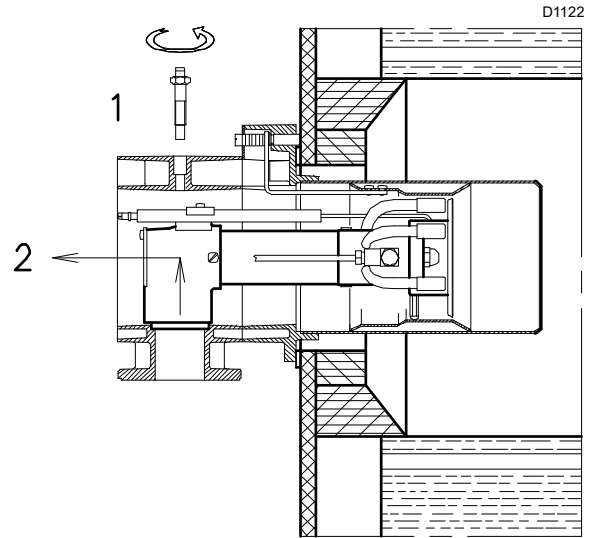

Fig. 12

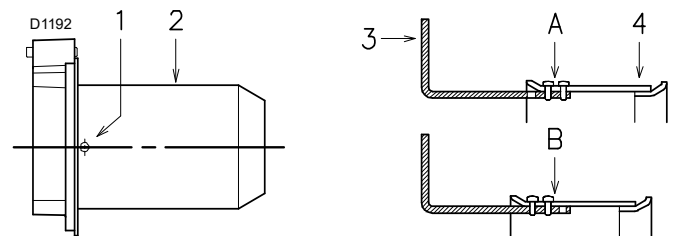

Fig. 13

4.7 Electrode positions



Check that the electrodes are positioned correctly, as in Fig. 14, complying with the dimensions indicated.

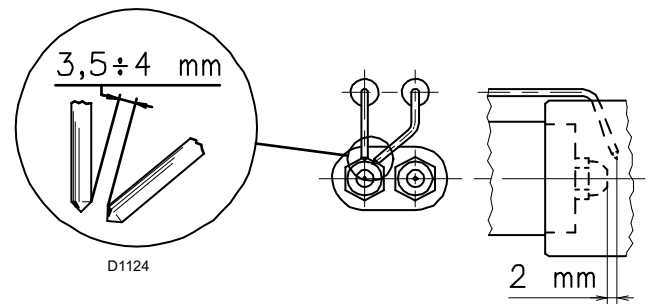

Fig. 14

4.8 Nozzle installation

The burner complies with the emission requirements of the EN 267 standard. In order to guarantee that emissions do not vary, recommended and/or alternative nozzles specified by Riello in the Instruction and warning booklet should be used.



ATTENTION

It is advisable to replace the nozzle once a year during periodical maintenance.



CAUTION

The use of nozzles other than those specified by Riello S.p.A. and inadequate regular maintenance may result into emission limits non-conforming to the values set forth by the regulations in force, and in extremely serious cases, into potential hazards to people and objects.

The manufacturing Company shall not be liable for any such damage arising from non-observance of the requirements contained in this manual.

- Remove the screw 1) and the internal part 2)(Fig. 15).
- Assemble the two nozzles with the socket spanner 1)(A Fig. 16) (16mm), after removing the plastic plugs 2)(A Fig. 16), passing from the central opening of the flame stability disc. Alternatively, loosen the screws 1)(B Fig. 16), remove the disc 2)(B Fig. 16), and replace the nozzles using the spanner 3)(B Fig. 16).
- The nozzle for the 1st stage of operation is the one beneath the ignition electrodes, Fig. 14 on page 17.



ATTENTION

- Do not use any sealing products such as: gaskets, tape or sealants.
- Be careful to avoid damaging the nozzle sealing seat.
- The nozzle must be screwed into place tightly but not to the maximum torque value provided by the wrench.

- Reassemble the burner on the guides 3)(Fig. 17) at about 100 mm from the pipe coupling 4), burner in the position shown in Fig. 11 on page 16;
- insert the electrode cables and then slide the burner up to the pipe coupling, the burner in the position indicated in Fig. 17
- refit screws 2)(Fig. 17) on slide bars 3);
- fix the burner to the pipe coupling with the screws 1);
- reconnect the light oil pipes by screwing the two fittings 6)(Fig. 11 on page 16).



ATTENTION

On closing the burner on the two guides it is advisable to gently pull the high voltage wires outwards until they are under slight tension.

4.8.1 Recommended nozzle

Both nozzles must be chosen from among those listed in table (Tab. H).

The first nozzle determines the delivery of the burner in the 1st stage.

The second nozzle works together with the 1st nozzle to determine the delivery of the burner in the 2nd stage.

The deliveries of the 1st and 2nd stages have to be within the value range indicated Tab. A on page 7.

Use nozzles with a 60° spray angle at the recommended pressure of 12 bar.

In general both nozzles have the same delivery.

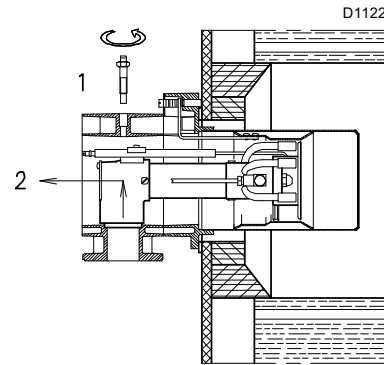

Fig. 15

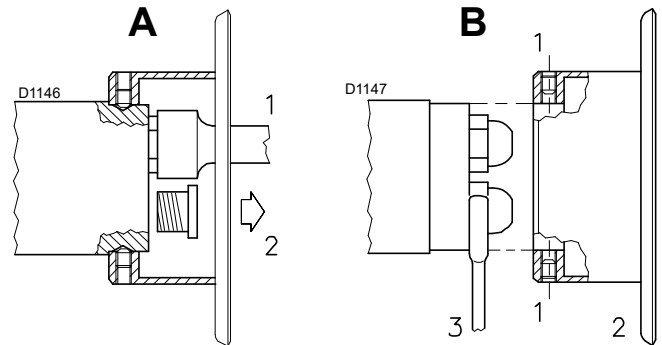

Fig. 16

20164422

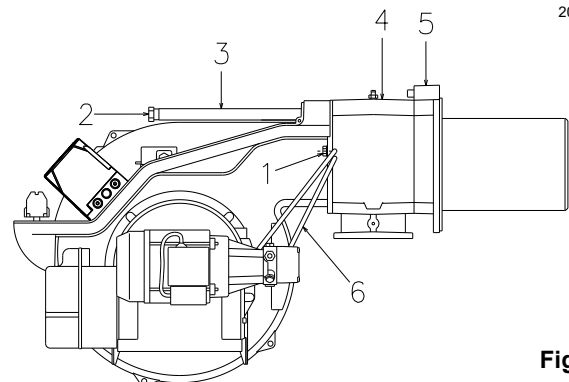

Fig. 17

GPH	Kg/h			kW
	10 bar	12 bar	14 bar	12 bar
5.00	19.2	21.2	23.1	251.4
5.50	21.1	23.3	25.4	276.3
6.00	23.1	25.5	27.7	302.4
6.50	25.0	27.6	30.0	327.3
7.00	26.9	29.7	32.3	352.3
7.50	28.8	31.8	34.6	377.2
8.00	30.8	33.9	36.9	402.1
8.30	31.9	35.2	38.3	417.5
8.50	32.7	36.1	39.2	428.2
9.00	34.6	38.2	41.5	453.1
9.50	36.5	40.3	43.8	478.0
10.0	38.4	42.4	46.1	502.9
10.5	40.4	44.6	48.4	529.0
11.0	42.3	46.7	50.7	553.9
12.0	46.1	50.9	55.3	603.7
12.3	47.3	52.2	56.7	619.1
13.0	50.0	55.1	59.9	653.5
13.8	53.1	58.5	63.3	693.8
14.0	53.8	59.4	64.5	704.5
15.0	57.7	63.6	69.2	754.3
15.3	58.8	64.9	70.5	769.7
16.0	61.5	67.9	73.8	805.3
17.0	65.4	72.1	78.4	855.1

Tab. H

4.9 Combustion head adjustment

4.9.1 Adjustments prior to ignition (with light oil)

The adjustment of the combustion head depends only on the maximum output of the burner in the 2nd stage.

- Turn the screw 5)(Fig. 18) until the notch indicated by the diagram (Fig. 19) corresponds with the front part of the flange 6)(Fig. 18).

Example burner RLS 100:

burner output in 2nd stage = 72 kg/h.

- The diagram (Fig. 19) shows that for this output, the adjustment of the combustion head is carried out on the notch 3, as in Fig. 18.

Pump adjustment

No adjustment of gas delivery is required.

The pump leaves the factory set at 12 bar, a pressure to be checked and eventually modified after the burner has been started. In this phase, therefore, limit to apply a pressure gauge on the specific pump connector.

Fan damper adjustment

For the initial ignition, leave the factory setting for the 1st and 2nd stages.

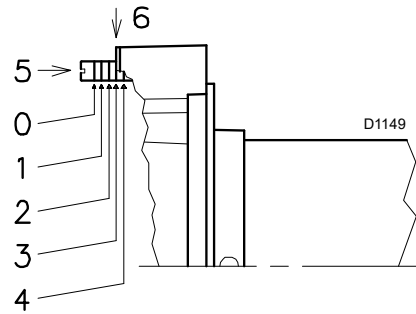

Fig. 18

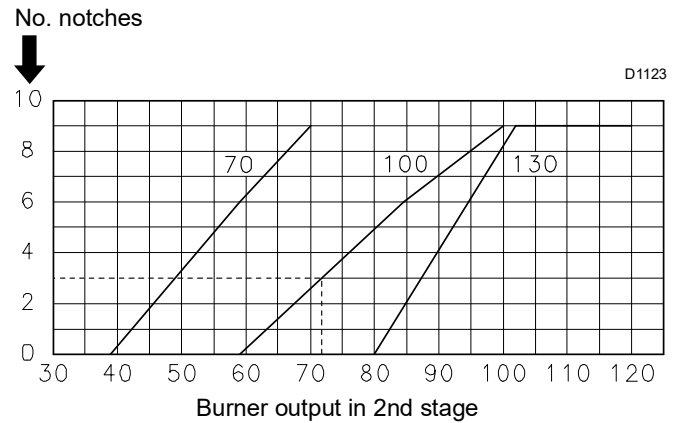

Fig. 19

4.10 Light oil supply



Explosion danger due to fuel leaks in the presence of a flammable source.

Precautions: avoid knocking, attrition, sparks and heat.

Make sure the fuel shut-off valve is closed before performing any operation on the burner.



ATTENTION

The fuel supply line must be installed by qualified personnel, in compliance with current standards and laws.

The burner is equipped with a self-priming pump which is capable of feeding itself within the limits listed in the table at the side.

Tank higher than burner A (Fig. 20)

The distance "P" must not exceed 10 meters in order to avoid subjecting the pump's seal to excessive strain; the distance "V" must not exceed 4 meters in order to permit pump self-priming even when the tank is almost completely empty.

Tank lower than burner B (Fig. 20)

Pump depression values higher than 0.45 bar (35°cm²Hg) must not be exceeded. Because at higher levels gas is released from the fuel; the pump becomes noisy and its lifetime is shortened.

It is good practice to ensure that the return and suction lines enter the burner from the same height; the suction line is more difficult to disconnect.

4.10.1 Loop circuit

The loop circuit is composed of a duct starting from the tank and going back to it, in which an auxiliary pump makes the pressurised fuel flow. A branch from the loop supplies the burner.

This circuit is extremely useful whenever the burner pump does not succeed in self-priming because the tank distance and/or height difference are higher than the values listed in Tab. I.

+/- H [m]	L [m]		
	12	14	16
4,0	24	46	80
3,0	21	40	70
2,0	18	35	60
1,0	15	28	51
0,5	13	26	46
0	12	23	41
-4,0	-	-	-
-3,0	-	6	12
-2,0	5	12	21
-1,0	8	17	31
-0,5	10	20	36

Tab. I

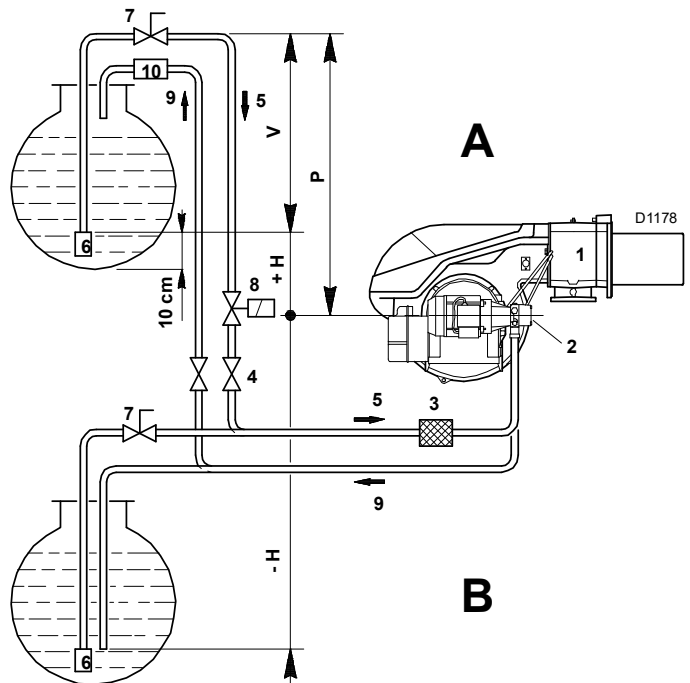

Fig. 20

Key (Fig. 20)

- H = Pump/Foot valve height difference
- L = Piping length
- Ø = Inside pipe diameter
- 1 = Burner
- 2 = Pump
- 3 = Filter
- 4 = Manual on/off valve
- 5 = Suction line
- 6 = Foot valve
- 7 = Quick closing manual valve with remote control (Italy only)
- 8 = On/off solenoid valve (Italy only)
- 9 = Return line
- 10 = Check valve (Italy only)

4.10.2 Hydraulic connections



- Make sure that the hoses to the pump supply and return line are installed correctly.

The pumps are equipped with a by-pass that connects return line with suction line. They are installed on the burner with the by-pass closed by screw 6)(Fig. 21).

It is therefore necessary to connect both hoses to the pump. The pump will break down immediately if it is run with the return line closed and the by-pass screw inserted.

Remove plugs from suction and return connectors of the pump. Insert the hose connections with the supplied seals into the connections and screw them down.



During the installation, hoses must not be stressed with twisting.

- Place the pipes so that they are not crushed or are in contact with hot parts of the boiler and so it is possible to open the burner.
- Connect, finally, the other end of the flexible hoses to the suction line and return line ducts by nipples supplied with the equipment.

4.10.3 Hydraulic circuit diagram

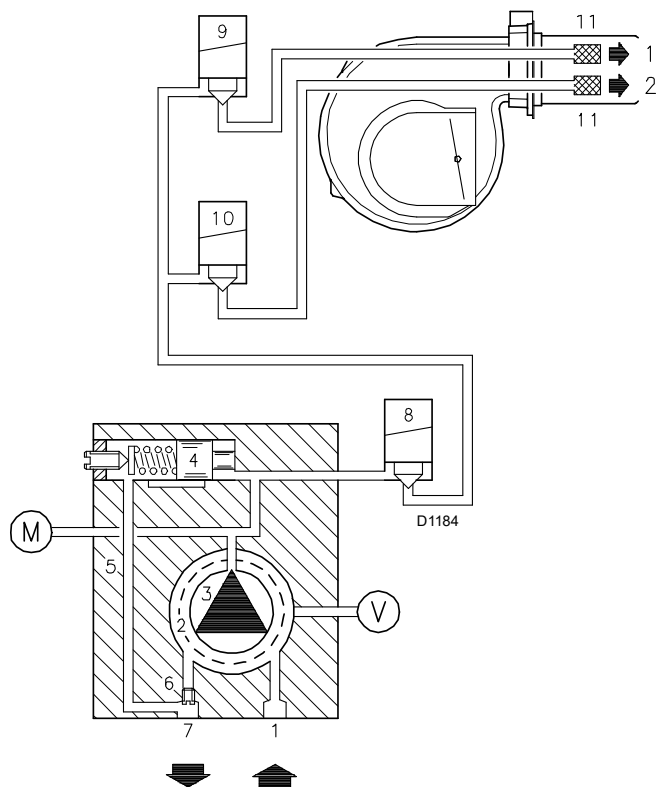

Fig. 21

Key (Fig. 21)

- 1 Pump suction line
- 2 Filter
- 3 Pump
- 4 Pressure adjuster
- 5 Return pipe
- 6 Bypass screw
- 7 Pump return line
- 8 Safety valve
- 9 1st stage valve
- 10 2nd stage valve
- 11 Filter
- M Pressure gauge
- V Vacuumeter connection

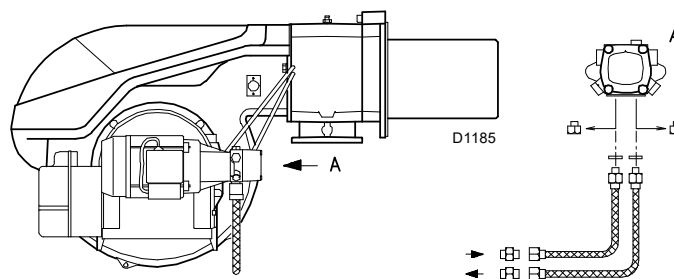

Fig. 22

4.11 Pump

4.11.1 Technical data

Pump	SUNTEC AJ 6 CC
Min. delivery rate at 12 bar pressure	220 kg/h
Delivery pressure range	10 - 20 bar
Max. suction depression	0.45 bar
Viscosity range	2.8 - 75 cSt.
Max. light oil temperature	60°C
Max. suction and return pressure	2 bar
Pressure calibration in the factory	12 bar
Filter mesh width	0,150 mm

Tab. J

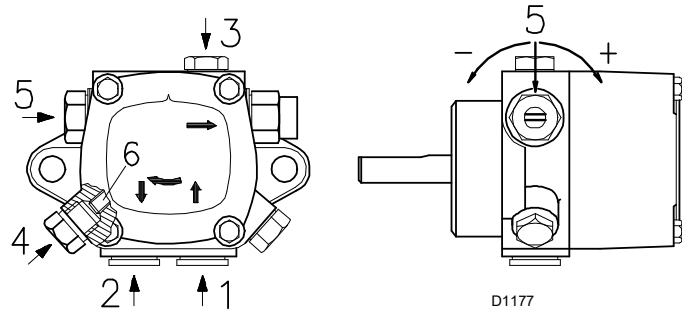

Fig. 23

Key (Fig. 23)

1	Suction line	G 1/4"
2	Return line	G 1/4"
3	Gauge connection	G 1/8"
4	Vacuometer connection	G 1/8"
5	Pressure adjuster	

4.11.2 Priming pump



ATTENTION

Before starting the burner, make sure that the tank return line is not clogged.

Obstructions in the line could cause the sealing organ located on the pump shaft to break.

Make sure that the valves on the suction line are open and that there is fuel in the tank.

In order for self-priming to take place, one of the screws 3) of the pump, see Fig. 23, must be loosened in order to bleed off the air contained in the suction line.



ATTENTION

The pump leaves the factory with the by-pass closed.

4.12 Gas supply



Explosion danger due to fuel leaks in the presence of a flammable source.

Precautions: avoid knocking, attrition, sparks and heat.

Make sure the fuel shut-off valve is closed before performing any operation on the burner.



The fuel supply line must be installed by qualified personnel, in compliance with current standards and laws.

4.12.1 Gas feeding line (Example) - Please refer to the gas train documentation for more information

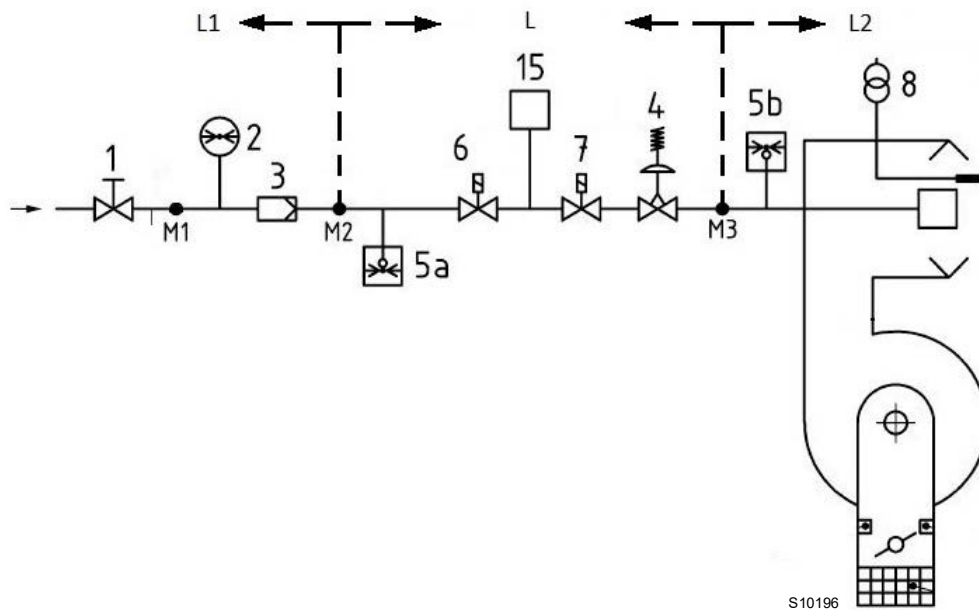

S10196

Fig. 24

Key (Fig. 24)

- 1 Manually operated shut-off valve
- 2 Pressure gauge
- 3 Filter
- 4 Governor
- 5a Low pressure protection device
- 5b Maximum gas pressure switch
- 6 1st safety shut-off device
- 7 2nd safety shut-off device
- 8 Ignition device
- 15 Valve leak detection control system
- L Gas train (supplied separately)
- L1 Responsibility of the installer
- L2 Burner
- M1 Pressure test point
- M2 Pressure test point
- M3 Pressure test point

4.12.2 Gas train

Type-approved in accordance with EN 676 and supplied separately from the burner.

4.12.3 Gas train installation



Disconnect the electrical power using the main switch.



Check that there are no gas leaks.



Pay attention when handling the train: danger of crushing of limbs.



Make sure that the gas train is properly installed by checking for any fuel leaks.



The operator must use the required equipment during installation.

The gas train must be connected to the gas connection 1) (Fig. 25), using the flange 2), the gasket 3) and the screws 4) supplied with the burner.

The train can enter the burner from the right or left side, depending on which is the most convenient, see Fig. 25.

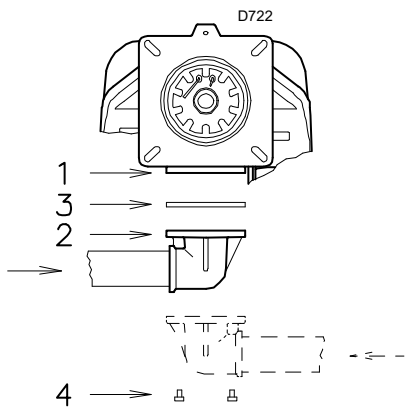

Fig. 25

4.12.4 Gas pressure

Tab. K indicates the pressure drops of the combustion head and gas butterfly valve, on the basis of the burner operating output.

Model	kW	1 Δp (mbar)		
		G20	G25	G31
RLS 70	465	5.5	8.2	6.3
	515	5.6	8.3	6.4
	565	5.7	8.5	6.5
	615	5.8	8.6	6.7
	665	5.9	8.8	6.8
	715	6.0	8.9	7.1
	765	6.1	9.1	7.4
	814	6.2	9.2	7.8
RLS 100	698	8.0	11.9	10.3
	760	8.3	12.4	10.5
	825	8.6	12.8	10.8
	890	8.9	13.3	11.1
	955	9.2	13.7	11.4
	1020	9.4	14.0	11.6
	1085	9.7	14.5	11.8
	1163	10.0	14.9	12.0
RLS 130	930	9.3	13.9	10.5
	1010	9.5	14.2	10.9
	1090	9.7	14.5	11.4
	1170	9.9	14.8	11.8
	1250	10.4	15.5	12.9
	1395	11.5	17.1	14.4

Tab. K



Data of head thermal power and gas pressure refer to operation with gas butterfly valve fully open (90°).

The values shown in Tab. K refer to:

- Natural gas G 20 NCV 9.45 kWh/Sm³ (8.2 Mcal/Sm³)
- Natural gas G 31 NCV 27 kWh/Sm³ (23.2 Mcal/Sm³)

Column 1

Combustion head pressure drop.

Gas pressure measured at test point 1)(Fig. 26 on page 25), with:

- combustion chamber at 0 mbar;
- Burner operating in 2nd stage
- Gas G20 (methane) - G31 (propane)

To calculate the approximate output at which the burner operates in the 2nd stage:

- subtract the combustion chamber pressure from the gas pressure measured at test point 1)(Fig. 26 on page 25).
- Find in Tab. K related to the burner concerned, the pressure value closest to the result of the subtraction.
- Read the corresponding output on the left.

Example RLS 100 with natural gas G20:

2nd stage operation

Gas pressure at test point 1)(Fig. 26) = 11.2 mbar

Pressure in combustion chamber = 2 mbar

 $11.2 - 2 = 9.2$ mbar

A pressure of 9.2 mbar, column 1, corresponds in Tab. K on page 24 to an output of 955 kW.

This value serves as a rough guide; the effective output must be measured at the gas meter.

To calculate the required gas pressure at test point 1)(Fig. 26), with the output fixed at that required for the burner in the 2nd stage:

- find the nearest output value in the Tab. K on page 24 for the burner in question.
- Read, on the right (column 1), the pressure at the test point 1)(Fig. 26).
- Add this value to the estimated pressure in combustion chamber.

Example RLS 100 with natural gas G20:

Desired output in 2nd stage: 955 kW

Gas pressure at an output of 210 kW = 9.2 mbar

Pressure in combustion chamber = 2 mbar

 $9.2 + 2 = 11.2$ mbar

pressure required at test point 1)(Fig. 26).

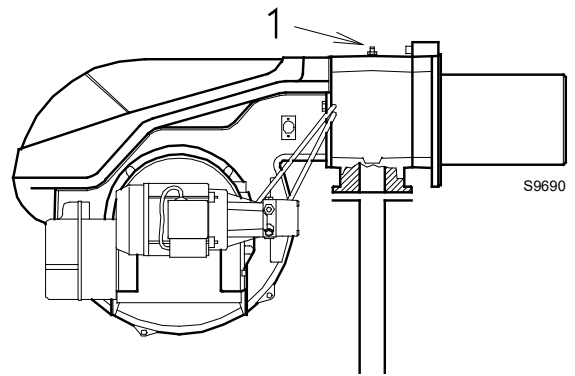
**Fig. 26**

4.13 Electrical connections

Notes on safety for the electrical wiring



- The electrical wiring must be carried out with the electrical supply disconnected.
- Electrical wiring must be made in accordance with the regulations currently in force in the country of destination and by qualified personnel. Refer to the wiring diagrams.
- The manufacturer declines all responsibility for modifications or connections different from those shown in the wiring diagrams.
- Check that the electrical supply of the burner corresponds to that shown on the identification label and in this manual.
- The burner has been type-approved for intermittent use. This means they should compulsorily be stopped at least once every 24 hours to enable the flame control to perform checks of its own start-up efficiency. Normally, burner stopping is guaranteed by the boiler's thermostat/pressure switch.
- If this is not the case, a time switch should be fitted in series to TL to stop the burner at least once every 24 hours. Refer to the wiring diagrams.
- The electrical safety of the device is obtained only when it is correctly connected to an efficient earthing system, made according to current standards. It is necessary to check this fundamental safety requirement. In the event of doubt, have the electrical system checked by qualified personnel. Do not use the gas tubes as an earthing system for electrical devices.
- The electrical system must be suitable for the maximum power absorption of the device, as indicated on the label and in the manual, checking in particular that the section of the cables is suitable for that level of power absorption.
- For the main power supply of the device from the electricity mains:
 - do not use adapters, multiple sockets or extensions;
 - make provisions for an omnipolar switch with a gap between the contacts of at least 3 mm (over-voltage category III), as required by current safety regulations.
- Do not touch the device with wet or damp body parts and/or in bare feet.
- Do not pull the electric cables.

Before carrying out any maintenance, cleaning or checking operations:



Disconnect the electrical supply from the burner by means of the main system switch.



Close the fuel shut-off valve.



Avoid condensate, ice and water leaks from forming.

If the cover is still present, remove it and proceed with the electrical wiring according to the wiring diagrams.

Use flexible cables according to standard EN 60 335-1.

4.13.1 Supply cables and external connections passage

All the cables to be connected to the burner terminal board 8 (Fig. 27) must be threaded through cable grommets.

The use of the cable grommets and the pre-blanked holes can be done in different manners; for example (Fig. 27):

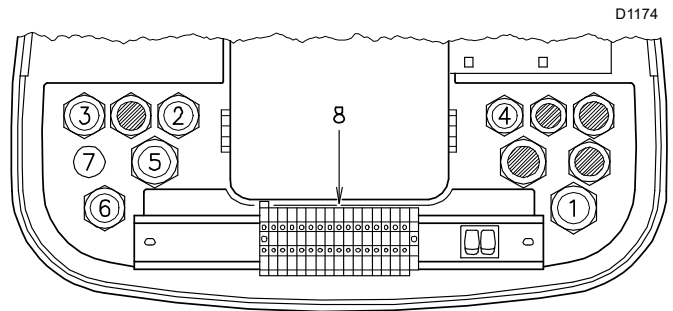

Fig. 27

Key (Fig. 27)

- | | | |
|---|---------|--|
| 1 | Pg 13.5 | Three-phase power supply |
| 2 | Pg 11 | Single-phase power supply |
| 3 | Pg 11 | TL remote control |
| 4 | Pg 9 | TR remote control |
| 5 | Pg 13.5 | Gas valves |
| 6 | Pg 13.5 | Gas pressure switch or device for leak detection control |
| 7 | Pg 11 | Bore, if you want to add a cable entry |



After carrying out maintenance, cleaning or checking operations, reassemble the cover and all the safety and protection devices of the burner.

4.14 Calibration of the thermal relay

The thermal relay serves to avoid damage to the motor due to an excessive absorption increase or if a phase is missing.

For calibration 2), refer to the table indicated in the electrical layout (electrical wiring in charge of the installer).

To reset, in case of an intervention of the thermal relay, press button "RESET" 1).

The button "STOP" 3) opens the NC contact (95-96) and stops the motor.

Insert a screwdriver in the window "TEST/TRIP" 4) and move it in the arrow direction (to the right) to carry out the thermal relay test.

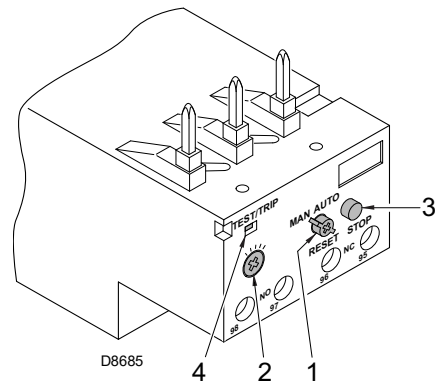

Fig. 28



The automatic reset can be dangerous.

This operation is not foreseen in the burner operation.

ATTENTION

4.15 Motor rotation

As soon as the burner starts, place yourself in front of the cooling fan of the fan motor and check that it turns anticlockwise (Fig. 29).

If this is not the case:

- put the switch of the burner to "0" (off) and wait until the flame control carries out the switching off phase.



DANGER

Disconnect the electrical supply from the burner by means of the system main switch.

- Invert the phases on the three-phase motor power supply.

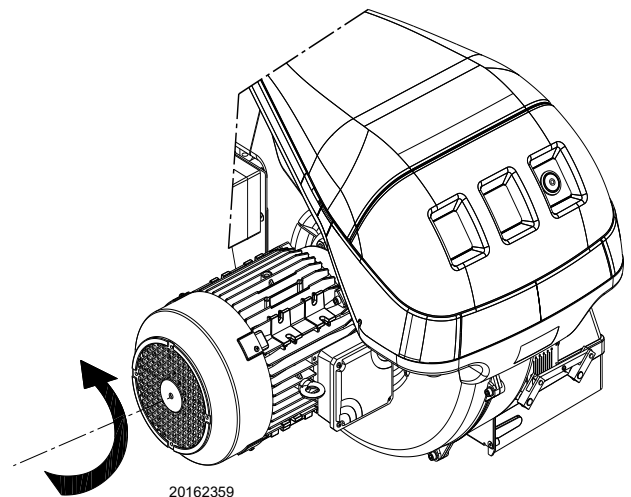

Fig. 29

5 Start-up, calibration and operation of the burner

5.1 Notes on safety for the first start-up



The first start-up of the burner must be carried out by qualified personnel, as indicated in this manual and in compliance with the standards and regulations of the laws in force.



Check the correct working of the adjustment, command and safety devices.



Before starting up the burner, refer to section "Safety test - with no gas supply" on page 35.

5.2 Adjustments prior to ignition (light oil)



It is recommended to adjust first the light oil burner and then the gas burner.
Carry out the fuel change with burner off.

The optimum calibration of the burner requires an analysis of the flue gases at the boiler outlet and interventions on the following points:

5.2.1 1st and 2nd stage nozzles

See information on page 18.

5.2.2 Combustion head

The adjustment of the combustion head already carried out on page 19 need not to be altered unless the 2nd stage output of the burner is changed.

5.2.3 Pump pressure

12 bar: this is the pressure calibrated in the factory which is usually sufficient for most purposes. Sometimes, this pressure must be adjusted to:

10 bar: in order to reduce fuel delivery. It is possible only if the ambient temperature remains above 0 °C;

14 bar: in order to increase fuel delivery or to ensure firings even at temperatures of less than 0 °C.

In order to change pump pressure, act on screw 5)(Fig. 23 on page 22).

(See information on page 22).

5.2.4 1st stage fan damper

Keep the burner operating at 1st stage by setting the switch 2)(Fig. 30) to the 1st stage position. The fan damper can be adjusted by operating the orange level of the servomotor ("Servomotor adjustment" on page 31).

5.2.5 2nd stage fan damper

Turn switch 2)(Fig. 30) to the 2nd stage position. The fan damper can be adjusted by operating the red level of the servomotor ,("Servomotor adjustment" on page 31).

5.3 Burner ignition (light oil)

Start the burner by closing the remote controls, with the switch 1)(Fig. 30) in the "ON" position and with the fuel selector switch set to "OIL" (Fig. 31).

The pump can be considered to be primed when the light oil starts coming out of the screw 3)(Fig. 23 on page 22). Stop the burner: set switch 1)(Fig. 30) to "OFF" and tighten the screw 3).

The time required for this operation depends upon the diameter and length of the suction tubing. If the pump fails to prime at the first start of the burner and the burner locks out, reset the burner and repeat the start-up operation.

Do not light the flame sensor or the burner will lock out.

During the first firing, during the passage from the 1st to the 2nd stage, there is a momentary lowering of the fuel pressure caused by the filling of the 2nd nozzle tubing. This lowering of the fuel pressure can cause the burner to lockout and can sometimes give rise to pulsations.

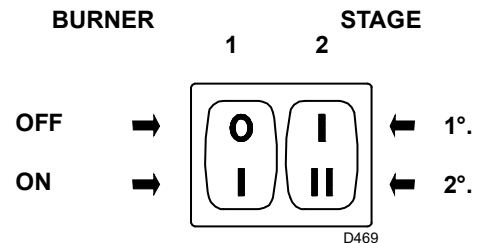

Fig. 30

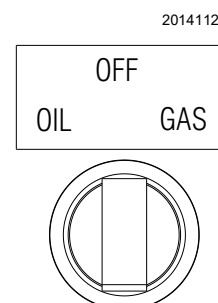

Fig. 31

5.4 Adjustments prior to ignition (gas)

Combustion head adjustment is already described on page 19.

In addition, the following adjustments must also be made:

- open the manual valves upstream of the gas train.
- Adjust the minimum gas pressure switch to the start of the scale (Fig. 39 on page 32).
- Adjust the air pressure switch to the start of the scale (Fig. 38 on page 32).
- Purge the air from the gas line. We recommend using a plastic tube routed outside the building and to purge air until gas is smelt.
- Fit a U-type pressure gauge (Fig. 32) to the gas pressure test point on the pipe coupling.
- Used to approximately calculate burner output in the 2nd stage using the Tab. K on page 24.
- Connect two lamps or testers in parallel to the two gas line solenoid valves VR1 and VS in order to check the exact moment at which voltage is supplied. This operation is not required if each of the two solenoid valves is equipped with a pilot light that signals voltage passing through.



Before starting up the burner, it is good practice to adjust the gas train so that ignition takes place in conditions of maximum safety, i.e. with gas delivery at the minimum.

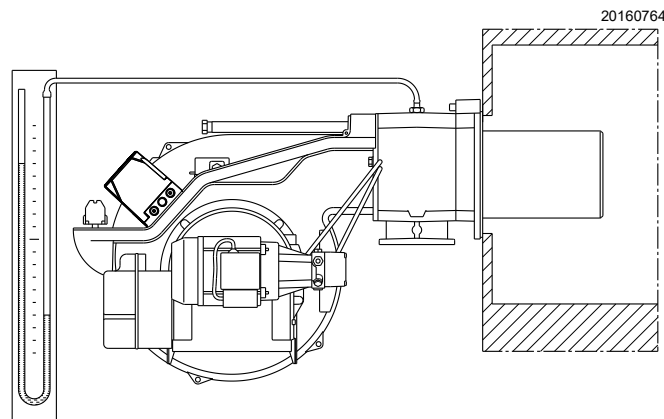

Fig. 32

5.5 Burner start-up (gas)



It is recommended to adjust first the light oil burner and then the gas burner.

Carry out the fuel change with burner off.

Close the remote controls and turn:

- switch 1)(Fig. 30 on page 28) in **"BURNER ON"** position;
- switch 2)(Fig. 30 on page 28) in **"1st STAGE"** position;
- fuel selector switch in **"GAS"** position (Fig. 33).

As soon as the burner starts, check that the lamps or the testers connected to the solenoid valves or the warning lights on the solenoid valves indicate no voltage presence. If voltage is present, stop the burner **immediately** and check the electrical wiring.

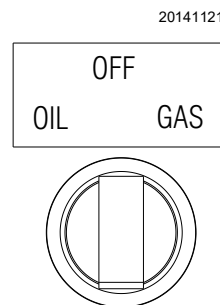

Fig. 33

5.6 Burner ignition

Once the above steps are completed, the burner should ignite.

If the motor starts but the flame does not appear and the flame control goes into lockout, reset and wait for a new ignition attempt.

If ignition does not occur, it is possible that gas is not reaching the combustion head within the safety time period of 3 seconds. Therefore, it is necessary to increase gas ignition delivery.

The arrival of gas to the sleeve is indicated by the U-type pressure gauge (Fig. 32).

If the burner locks out again, refer to chapter "Faults - Possible causes - Solutions" on page 39.



In the event the burner stops, in order to prevent any damage to the installation, do not unblock the burner more than twice in a row. If the burner locks out for a third time, contact the customer service.



In the event there are further lockouts or faults with the burner, the maintenance interventions must only be carried out by qualified, authorised personnel, in accordance with the contents of this manual and in compliance with the standards and regulations of current laws.

Once ignition has taken place, proceed with global calibration operations.

5.7 Change of fuel

There is a change of fuel options:

- with selector 9)(Fig. 5 on page 12);



Change the fuel only when the burner is off.

5.8 Burner adjustment (gas)

The optimum adjustment of the burner requires an analysis of flue gases at the boiler outlet.

Adjust in sequence:

- 1 Burner output in 2nd stage
- 2 Burner output in 1st stage
- 3 Output upon ignition
- 4 Air pressure switch
- 5 Gas minimum pressure switch

Gas train: use the train for natural gas, see page 24, with a 1" 1/2" or 2" diameter.

5.8.1 Output in 2nd stage

2nd stage output must be selected within the firing rate range indicated in page 9.

Turn switch 2)(Fig. 30 on page 28) to the 2nd stage position: the servomotor will open the air damper on the value previously set for the light oil and will control the opening of the 2nd stage VR2 gas valve.

Adjustment of gas delivery

Adjust the gas delivery to the air quantity.

- If delivery needs to be reduced, diminish the adjuster outlet gas pressure; if it is already very low, slightly close the 2nd stage VR2 valve.
- If delivery needs to be increased, increase the adjuster outlet gas pressure.

5.8.2 Output in 1st stage

1st stage output must be selected within the firing rate range indicated in page 9.

Turn switch 2)(Fig. 30 on page 28) to the 1st stage position: the servomotor will close the air damper on the value previously set for the light oil and will control the opening of the 1st stage VR1 gas valve.

Adjustment of gas delivery

Adjust the gas delivery to the air quantity by operating the 1st stage VR1 gas valve.

5.8.3 Ignition output (gas)



For safety purposes and correct product operation, the ignition output, if it is adjustable, must be carried out by authorized personnel and in compliance with the standards and regulations of the laws in force.

5.8.4 Operation with LPG - Propane - Butane

The RLS 70 - 100 - 130 burners can operate also with LPG - Propane-Butane.

In this case it is essential to screw the six nozzles 2)(Fig. 34), supplied as equipment, on the holes 1)(Fig. 34). Apply also the eight diffusers 3)(Fig. 34), supplied as equipment, on the pipes 4)(Fig. 34) using the screws supplied as equipment. Apply the adhesive label for LPG operation near the characteristics label.

The firing rate and the adjustment of the burner are the same as for natural gas.

The pressure of the G31 gas (Propane) is shown on page 24.

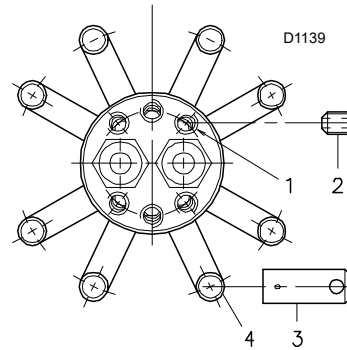

Fig. 34

5.9 Servomotor adjustment

The servomotor (Fig. 35) adjusts the air damper. The servomotor rotates by 90° in 5 seconds.



ATTENTION

Do not alter the factory setting for the 4 cams; check only that they are as shown below.

- Cam I: RED 60°**
Limits rotation toward maximum position. When the burner is at MAX output, the air butterfly valve must be open.
- Cam II: BLUE 0°**
Limits rotation toward minimum position. When the burner is shut down, the air damper must be closed.
- Cam III: ORANGE 20°**
Adjusts the firing and output position in 1st stage.
- Cam IV: BLACK 50°**
Output signal for 2nd stage and/or hour counter.

NOTE:

The servomotor follows the adjustment of the black and orange lever when the angle of the cam is reduced.

- If the angle needs to be increased, pass to the 2nd stage and increase the angle, then return to the 1st stage to check the effect of the adjustment.
- For any necessary adjustment of cam III, use the screwdriver 11)(Fig. 37).
- For any necessary adjustment of cam IV, use the specific key 10)(Fig. 36) place inside the servomotor.

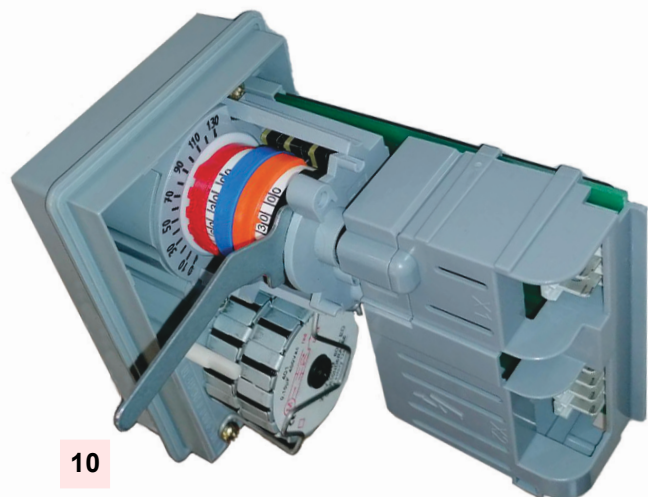

S10142

Fig. 36

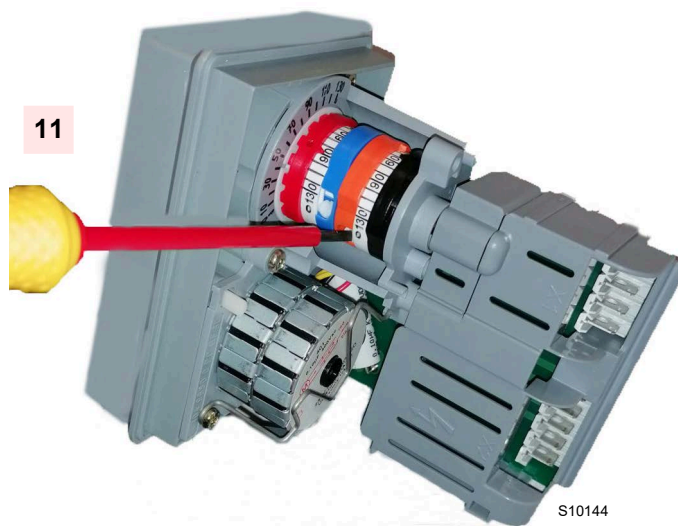

S10144

Fig. 37

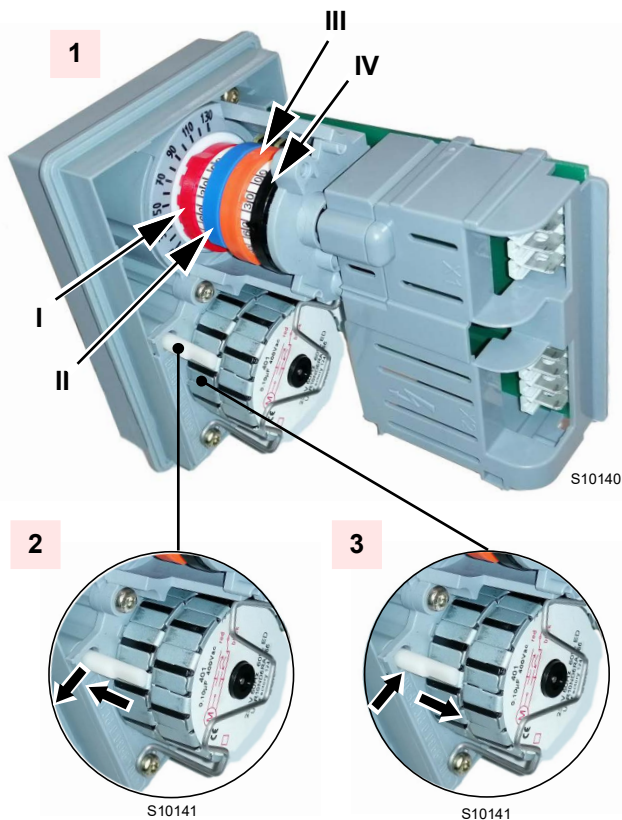

Fig. 35

Key

- 1 Servomotor
- 2 Servomotor 1) - cam 4): constrained
- 3 Servomotor 1) - cam 4): released
- 10 Spanner for adjusting cam IV (Fig. 36)
- 11 Screw driver for adjusting cam III (Fig. 37)

5.10 Pressure switch adjustment

5.10.1 Air pressure switch - check CO

Adjust the air pressure switch after performing all other burner adjustments with the air pressure switch set to the start of the scale (Fig. 38).

With the burner operating in 1st stage, increase adjustment pressure by slowly turning the relevant knob clockwise until the burner locks out.

Then turn the knob anticlockwise by about 20% of the set point and repeat burner start-up to ensure it is correct.

If the burner locks out again, turn the knob slightly anticlockwise.

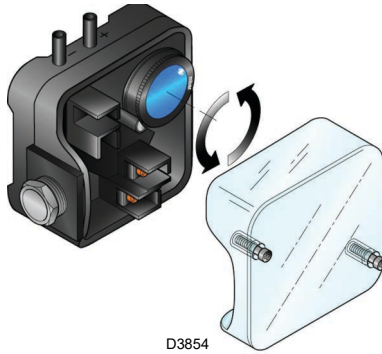

Fig. 38



ATTENTION

As a rule, the air pressure switch must limit the CO in the fumes to less than 1% (10,000 ppm).

To check this, insert a combustion analyser into the chimney, slowly close the fan suction inlet (for example with cardboard) and check that the burner locks out, before the CO in the fumes exceeds 1%.

The incorporated air pressure switch can work in a 'differential' mode if connected with two pipes. If a strong depression in the combustion chamber during the pre-purging phase does not allow the air pressure switch to switch, this can be obtained by applying a second tube between the air pressure switch and the suction inlet of the fan. In this way, the pressure switch will work in differential mode.



ATTENTION

The use of the air pressure switch with differential operation is allowed only in industrial applications and where rules enable the air pressure switch to control only fan operation without any reference to CO limit.



ATTENTION

Connecting the air pressure switch in differential mode, the burner will no longer be certified according to the EN 676 standard.

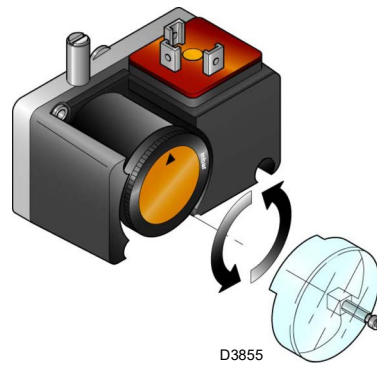

Fig. 39

5.10.2 Gas minimum pressure switch

The purpose of the minimum gas pressure switch is to prevent the burner from operating in an unsuitable way due to too low gas pressure.

Adjust the minimum gas pressure switch (Fig. 39) after having adjusted the burner, the gas valves and the gas train stabiliser. With the burner operating at maximum output:

- install a pressure gauge downstream of the gas train stabiliser (for example at the gas pressure test point on the burner combustion head);
- choke slowly the manual gas cock until the pressure gauge detects a decrease in the pressure read of about 0.1 kPa (1 mbar). In this phase, verify the CO value which must always be less than 100 mg/kWh (93 ppm).
- Increase the adjustment of the gas pressure switch until it intervenes, causing the burner shutdown;
- remove the pressure gauge and close the cock of the gas pressure test point used for the measurement;
- open completely the manual gas cock.



ATTENTION

1 kPa = 10 mbar

5.11 Operation sequence of the burner

5.11.1 Burner start-up

- 0 s** TL closes, fan motor starts, (in case of oil operation, pump motor starts)
- 6 s** servomotor starts, maximum opening.
- 11 s** air damper is at its maximum opening
- 42 s** servomotor closing phase starts at the minimum output.
- 45 s** air damper is in the ignition point position (minimum output)
- 48 s** ignition transformer strikes a spark
- 54 s** 1st stage fuel valve opens
- 57 s** ignition discharge ends
- 66 s** with TR in 2nd stage, servomotor reaches its maximum opening and the second fuel valve opens.

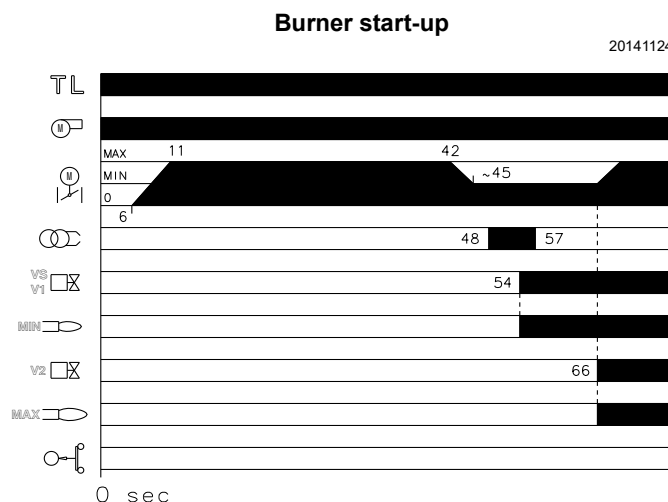

Fig. 40

5.11.2 Ignition failure

If the burner does not fire, it goes into lockout within 3 seconds after the valve opens and approximately 57 seconds after the TL closes and the pre-purging phase starts and lasts 17 seconds.

5.11.3 Burner flame goes out during operation

If the flame should accidentally go out during operation, the burner will lock out within 1s.

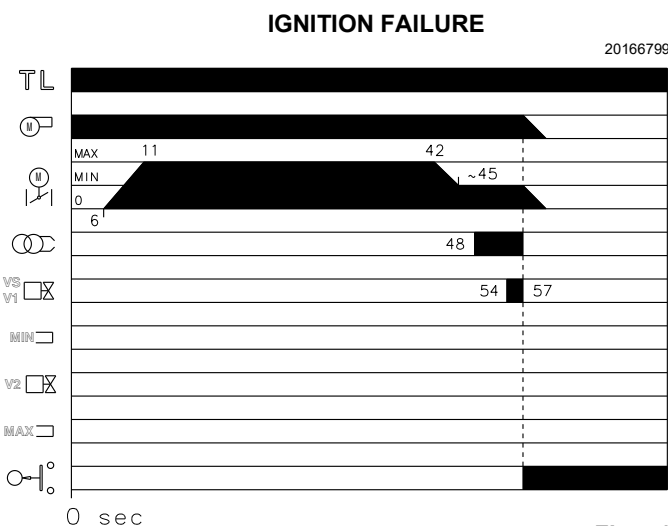

Fig. 41

5.11.4 LED PANEL

It gives 6 information through the lighting up of the LEDs. See Fig. 42.

Key:

D478

- POWER** = Voltage present
- = Fan motor lockout (red)
- = Burner lockout (red)
- = 2nd stage operation
- = 1st stage operation
- = Burner operation

D489

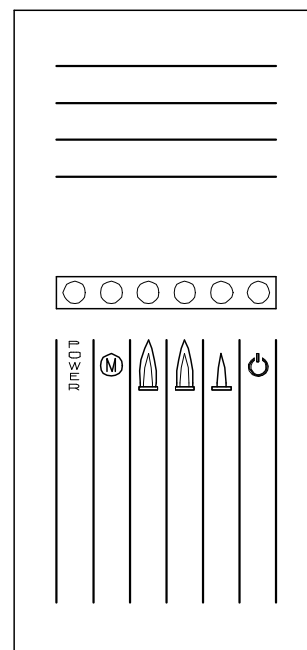





Fig. 42

5.12 Final checks (with burner operating)

<ul style="list-style-type: none"> ➤ Open the thermostat/pressure switch TL ➤ Open the thermostat/pressure switch TS 		The burner must stop
<ul style="list-style-type: none"> ➤ Turn the knob of the gas maximum pressure switch to the minimum end of scale position ➤ Turn the air pressure switch knob to the maximum end of scale position 		The burner must stop in lockout
<ul style="list-style-type: none"> ➤ Turn off the burner and cut off the power ➤ Disconnect the minimum gas pressure switch connector 		The burner must not start
<ul style="list-style-type: none"> ➤ Disconnect electrically the flame sensor 		The burner must stop in lockout due to ignition failure

Tab. L



ATTENTION

Make sure that the mechanical locking systems on the various adjustment devices are fully tightened.

6 Maintenance

6.1 Notes on safety for the maintenance

The periodic maintenance is essential for the good operation, safety, yield and duration of the burner.

It allows you to reduce consumption and polluting emissions and to keep the product in a reliable state over time.



The maintenance interventions and the calibration of the burner must only be carried out by qualified, authorised personnel, in accordance with the contents of this manual and in compliance with the standards and regulations of current laws.

Before carrying out any maintenance, cleaning or checking operations:



Disconnect the electrical supply from the burner by means of the main system switch.



Close the fuel shut-off valve.



Wait for the components in contact with heat sources to cool down completely.

6.2 Maintenance programme

6.2.1 Maintenance frequency



The gas combustion system should be checked at least once a year by a representative of the manufacturer or another specialised technician.

6.2.2 Safety test - with no gas supply

To perform commissioning in safety conditions, it is very important to check correct wiring between gas valves and burner.

For this purpose, after checking that connections comply with the burner wiring diagrams, it is necessary to carry out a start-up cycle with gas cock closed (dry test).

- 1 The manual gas valve must be closed using the locking/unlocking device ("Lock-out / tag out" procedure).
- 2 Ensure that burner limit electrical contacts are closed
- 3 Ensure that minimum gas pressure switch contact is closed
- 4 Try to start the burner.

The start-up cycle must occur according to the following steps:

- Fan motor start-up for pre-purging
- Gas valve leak detection control, if applicable.
- Pre-purging completion
- Achievement of the ignition point
- Power supply of the ignition transformer
- Supply of gas valves.

As gas is closed, the burner cannot ignite and its flame control will switch to stop or safety lockout condition.

The actual supply of gas valves can be checked by inserting a tester; some valves are equipped with lights (or closing/opening position indicators) that activate as soon as they are powered.



IF POWER SUPPLY OF GAS VALVES OCCURS IN UNEXPECTED MOMENTS, DO NOT OPEN THE MANUAL VALVE, DISCONNECT POWER SUPPLY, CHECK WIRINGS, CORRECT THE ERRORS AND CARRY OUT THE WHOLE TEST AGAIN.

6.2.3 Checking and cleaning



The operator must use the required equipment during maintenance.

Combustion

Carry out an analysis of the combustion flue gases. Significant differences with respect to the previous measurements indicate the points where most care should be exercised during maintenance.

Combustion head

Open the burner and make sure that all components of the combustion head are in good condition, not deformed by the high temperatures, free of impurities from the surroundings and correctly positioned.

Flame inspection window

Clean the glass of the flame inspection window.

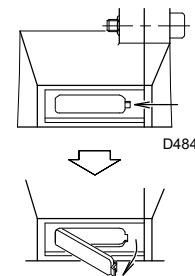

Fig. 43

Electrical current to flame sensor (Fig. 44)

Clean the glass cover from any dust that may have accumulated. To remove the sensor pull it outwards with force; it is inserted only by pressure.

Min. value for a good work: 70 μ A.

If the value is lower, it could be due to:

- exhausted sensor;
- low voltage (lower than 187 V);
- bad regulation of the burner.

In order to measure the current, use a microammeter of 100 μ A d.c., connected in series to the sensor, as in the scheme, with a capacitor of 100 μ F - 1V d.c. at the same level of the instrument.

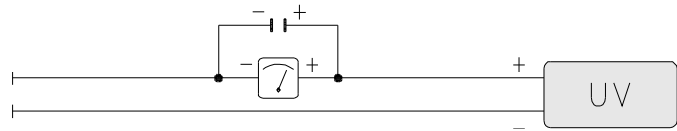

Fig. 44

Burner

Check that there are not excess wear or loosen screws. The screws securing the electrical leads in the burner plugs should also be fully tightened.

Clean the outside of the burner.

Clean and grease the adjustable profile of the cams.

Fan

Check to make sure that no dust has accumulated inside the fan or on its impellers, as this condition will cause a reduction in the air flow rate and provoke polluting combustion.

Boiler

Clean the boiler as indicated in its accompanying instructions in order to maintain all the original combustion characteristics intact, especially: the flue gas temperature and combustion chamber pressure.

LIGHT OIL OPERATION

Pump

The delivery pressure must comply with the table on page 22.

The depression must be less than 0.45 bar.

Unusual noise must not be evident during pump operation.

If the pressure is unstable, or the pump runs noisily, the flexible hose must be detached from the line filter and the fuel must be sucked from a tank located near the burner.

This measure permits the cause of the anomaly to be traced to either the suction piping or the pump.

If the problem lies in the suction line, check the filter is clean and that air is not entering the piping.

Filters

Check the filtering baskets on line and at nozzle present in the system.

Clean or replace if necessary.

If rust or other impurities are observed inside the pump, use a separate pump to lift any water and other impurities that may have deposited on the bottom of the tank.

Nozzles

It is advisable to replace nozzles once a year during periodical maintenance.

Do not clean the nozzle openings.

Flexible hoses

Check to make sure that the hoses are still in good condition.

Fuel tank

Approximately every 5 years, suck any water on the bottom of the tank using a separate pump.

Combustion

If the combustion values measured before starting maintenance do not comply with applicable Standards or do not indicate efficient combustion, consult the table below or contact our Technical Support Service to implement the necessary adjustments.

EN 267	Air excess		CO
	Max. output $\lambda \leq 1.2$	Min. output $\lambda \leq 1.3$	
Theoretical max CO ₂ 0 % O ₂	CO ₂ % Calibration		mg/kWh
	$\lambda = 1.2$	$\lambda = 1.3$	
15.2	12.6	11.5	≤ 100

Tab. M

GAS OPERATION

Gas leaks

Make sure that there are no gas leaks on the pipe between the gas meter and the burner.

Gas filter

Change the gas filter when it is dirty.

Combustion

If the combustion values measured before starting maintenance do not comply with applicable Standards or do not indicate efficient combustion, consult the table below or contact our Technical Support Service to implement the necessary adjustments.

EN 676		Air excess		CO
		Max. output $\lambda \leq 1.2$	Max. output $\lambda \leq 1.3$	
GAS	Theoretical max CO ₂ 0 % O ₂	CO ₂ % Calibration		mg/kWh
		$\lambda = 1.2$	$\lambda = 1.3$	
G 20	11.7	9.7	9	≤ 100
G 25	11.5	9.5	8.8	≤ 100
G 30	14.0	11.6	10.7	≤ 100
G 31	13.7	11.4	10.5	≤ 100

Tab. N

6.2.4 Combustion control (gas)

CO₂

It is advisable to adjust the burner with a CO₂ not greater than about 10% (gas with Ncv 8600 kcal/m³). In this way it is avoided that a small decalibration (for example a variation in the tension) could cause a combustion with an air defect and with the subsequent formation of CO.

CO

It should not exceed 100 mg/kWh.

6.2.5 Safety components

The safety components should be replaced at the end of their life cycle indicated in the following table.

The specified life cycles do not refer to the warranty terms indicated in the delivery or payment conditions.

Safety component	Life cycle
Flame control	10 years or 250,000 operation cycles
Flame sensor	10 years or 250,000 operation cycles
Gas valves (solenoid)	10 years or 250,000 operation cycles
Pressure switches	10 years or 250,000 operation cycles
Pressure adjuster	15 years
Servomotor (electronic cam)	10 years or 250,000 operation cycles
Oil valve (solenoid)	10 years or 250,000 operation cycles
Oil regulator	10 years or 250,000 operation cycles
Pipes/ oil fittings (metallic)	10 years
Fan impeller	10 years or 500,000 start-ups

Tab. O

6.3 Opening the burner



DANGER

Disconnect the electrical supply from the burner by means of the main system switch.



DANGER

Close the fuel shut-off valve.



Wait for the components in contact with heat sources to cool down completely.

- Loosen the screws 1) and remove the cover 2)
- Disconnect the light oil pipes 7)
- Remove the screws 3) and move the burner backwards by about 100 mm on the slide bars 4).
- Disconnect the electrode cables, then completely retract the burner.

At this point it is possible to extract the inner part 5) after having removed the screw 6)(Fig. 45).

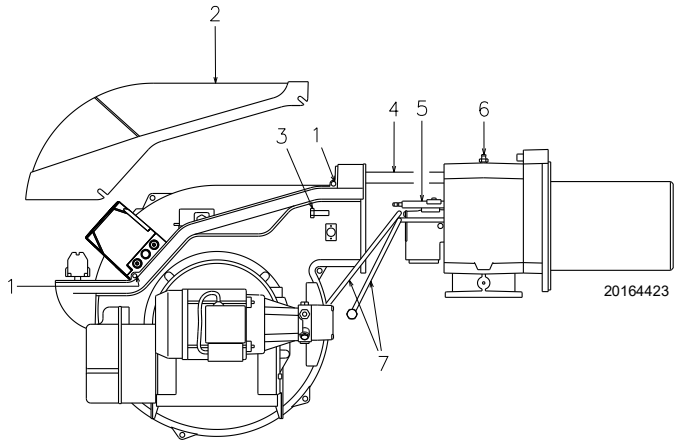

Fig. 45

6.4 Closing the burner

- Push the burner to approximately 100 mm from the pipe coupling.
- Reconnect the cables and slide in the burner until it comes to a stop.
- Replace the screws 3) and carefully pull the cables outwards until they are slightly taut.
- Reconnect the light oil pipes.



After carrying out maintenance, cleaning or checking operations, reassemble the cover and all the safety and protection devices of the burner.

7 Faults - Possible causes - Solutions

The LFL1... flame control is equipped with a lockout indicator (Fig. 46) that turns during the start-up programme, and is visible from the small lockout window.

When the burner does not start or stops, due to a failure, the symbol that appears on the indicator indicates the type of interruption. The positions of the lockout indicator are shown in Fig. 47.



Lockout indicator

- a-b Start-up sequence
- b(b') Idle stages (without contact confirmation)
- b(b')-a Post-purging programme

Fig. 46

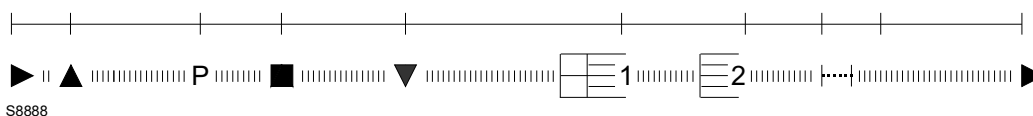

Fig. 47

Fuse replacement

The fuse 2)(Fig. 48) is in the rear part of the flame control. A spare fuse 1) is also available: it can be extracted after breaking the panel tab A) that houses it. In the event that fuse 2) has been tripped, replace it as shown in Fig. 48.

Find a list of faults, causes and possible solutions for a set of failures that may occur and result in irregular burner operation or no functioning at all.

If a burner malfunction is detected, first of all:

- check that the electrical wiring is adequately connected;
- check whether fuel is delivered;
- check that every adjustment parameter is adequately set.



ATTENTION

In the event the burner stops, in order to prevent any damage to the installation, do not unblock the burner more than twice in a row. If the burner locks out for a third time, contact the customer service.



DANGER

In the event there are further lockouts or faults with the burner, the maintenance interventions must only be carried out by qualified, authorised personnel, in accordance with the contents of this manual and in compliance with the standards and regulations of current laws.

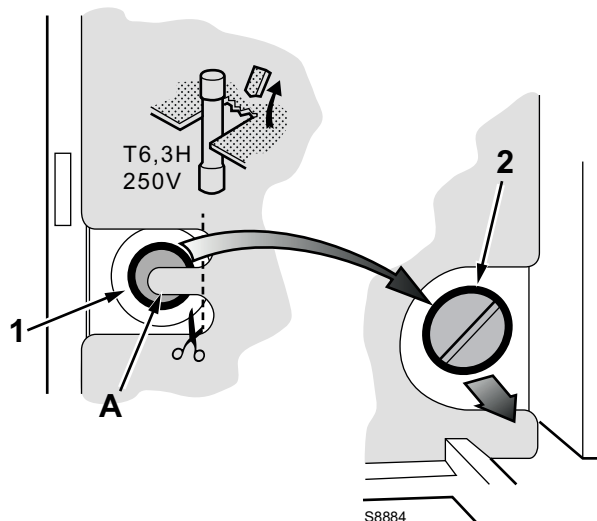

Fig. 48

7.1 Light oil operation

Symbol	Problem	Probable cause	Suggested remedy
◀	The burner does not start	Limiter or safety control device open	Adjust or replace
		Flame control lockout	Release
		Fan motor lockout	Release the thermal relay
		No electrical power supply	Close all switches - check connections
		No light oil	Check the light oil supply circuit
		Flame control fuse interrupted	Replace
		Pump is jammed	Replace
		Faulty motor remote control switch	Replace
	The burner does not come on and the lockout appears	Defective flame control	Replace
		Faulty electrical motor	Replace
		Defective safety solenoid valve	Replace
		Flame simulation	Replace the flame control
▲	The burner starts but stops at maximum air damper setting	Flame sensor short circuit	Replace flame sensor
		Two-phase electrical supply, thermal relay steps in	Reset the thermal relay at return of the three phases
▲	The burner starts but stops at maximum air damper setting	The servomotor contact does not intervene	Adjust cam or replace servomotor
P	The burner starts and then goes into lockout	Air pressure switch poorly adjusted	Adjust it
		Pressure switch pressure point pipe blocked	Clean
■	The burner starts and then goes into lockout	Failure to the flame detection circuit	Replace flame control
▼	The burner remains in pre-purging phase	The servomotor contact III does not intervene	Adjust cam or replace servomotor
1	Once the pre-purging and the safety time has elapsed the burner goes into lockout without the flame appearing	No fuel in the tank, or water on the bottom	Refill with fuel, or remove the water
		Bad head and damper adjustments	Adjust
		High voltage cable defective or grounded	Replace
		High voltage cable deformed by high temperature	Replace and protect
		Bad electrical wiring on valves or transformer	Check
		Pump unprimed	Prime it
		Pump suction line connected to return line	Correct connection
		Soiled filters (nozzle line)	Clean
		Valves up-line from pump closed	Open them
		Opposite motor rotation	Change electrical wiring to the motor
		Light oil solenoid valves do not open	Check connections and solenoids
		Pilot burner does not work	Check
		Defective flame control	Replace
		Ignition electrode incorrectly adjusted	Adjust it
		Electrode grounded due to broken insulation	Replace
		Motor/pump coupling broken	Replace
	Faulty ignition transformer	Replace	
	The flame ignites regularly but the burner goes into lock out at the end of the safety time	Faulty flame sensor or defective flame control	Replace flame sensor or flame control
		Dirty flame sensor	Clean
		Smoke in flame (dark Bacharach)	Little air
Incorrect pump pressure			Adjust
Nozzle filter clogged			Clean or replace
Boiler room air vents insufficient			Increase
Dirty or worn nozzle			Replace
	Smoke in flame (yellow Bacharach)	Flame disk soiled, loose or deformed	Clean it, tighten it or replace it
		Too much air	Adjust head and air dampers

Symbol	Problem	Probable cause	Suggested remedy
	Ignition with pulses or flame failure, delayed ignition	Poorly adjusted head	Adjust
		Incorrectly adjusted fan air damper: too much air	Adjust
		Nozzle not fit for burner or boiler	See nozzle table
		Defective nozzle	Replace
		Unsuitable pump pressure	Adjust
		Ignition electrode not adjusted correctly or soiled	Adjust it
		Output during ignition phase is too high	Reduce
	The burner does not pass to the 2nd stage	Remote control device TR fails to close	Adjust or replace
		Defective flame control	Replace
	Uneven fuel supply	Understand whether the cause lies in the pump or the fuel supply system	Supply fuel to the burner from a tank positioned near the burner itself
	Pump rusty on the inside	Water in the tank	Remove the water with a pump
	Noisy pump, unstable pressure	Air has entered the suction line	Block the couplings
		Depression value too high (higher than 35 cm Hg):	
		Excessive difference of level between burner and tank	Power the burner from a loop circuit
		Piping diameter too small	Increase
		Dirty suction line filters	Clean
		Suction line valves closed	Open them
		The paraffin solidifies due to the low temperature	Put additive in the light oil
	Pump unprimes after prolonged pause	Return pipe not immersed in fuel	Bring it to the same height as the suction line
		Air in the suction line	Block the couplings
	Pump leaks light oil	Loss of sealing organ	Replace the pump
	Dirty combustion head	Dirty nozzle or nozzle filter	Replace
		Unsuitable nozzle delivery or angle	See recommended nozzles
		Loose nozzle	Block it
		Environmental impurities on flame stability disc	Clean
		Incorrect head adjustment, or little air	Adjust it, opening the damper
		Blast tube length not suitable for the boiler	Contact the boiler manufacturer
I	Burner goes into lockout during operation	Flame sensor faulty or dirty	Replace it or clean it
		Air pressure switch faulty	Replace

Tab. P

7.2 Gas operation

Symbol	Problem	Probable cause	Suggested remedy
◀	The burner does not start	No electrical power supply	Close all switches and check connections
		A limit or safety thermostat/pressure switch open	Adjust or replace
		Flame control lockout	Release the flame control
		Flame control fuse interrupted	Replace it
		Incorrect electrical wiring	Check
		Defective flame control	Replace
		No gas supply	Open the manual valves between meter and train
		Mains gas pressure insufficient	Contact your GAS COMPANY
		Minimum gas pressure switch fails to close	Adjust or replace
		Air pressure switch in operating position	Adjust or replace
		The servomotor contact does not intervene (closure cam 0°)	Adjust the closure cam 0° or replace the servomotor
	The burner does not come on and the lockout appears	Flame simulation	Replace the flame control
		Faulty motor remote control switch	Replace
		Defective electrical motor	Replace
▲	The burner starts but stops at maximum air damper setting	Motor lockout	Release the thermal relay
		The servomotor contact does not intervene (maximum cam opening)	Cam adjustment (maximum opening) or replace the servomotor
P	The burner starts and then goes into lockout	Air pressure switch does not switch owing to lack of air pressure:	
		Air pressure switch poorly adjusted	Adjust or replace
		Pressure switch pressure point pipe clogged	Clean
		Poorly adjusted head	Adjust
		Dirty fan	Clean
■	The burner turns on and then remains in lockout mode	High depression in the furnace	Contact our Technical Department
		Failure to the flame detection circuit	Replace the flame control
▼	The burner remains in pre-purging phase	The servomotor contact does not intervene (minimum cam)	Cam adjustment (minimum) or replace the servomotor

Symbol	Problem	Probable cause	Suggested remedy
1	Once the pre-purging and the safety time has elapsed the burner goes into lockout without the flame appearing	The GAS solenoid valve lets too little gas through	Increase
		The GAS solenoid valve does not open	Replace the coil or the rectifier panel
		Gas pressure too low	Increase pressure at governor
		Ignition electrode incorrectly adjusted	Adjust it
		Electrode grounded due to broken insulation	Replace
		High voltage cable defective or grounded	Replace
		High voltage cable deformed by high temperature	Replace and protect
		Faulty ignition transformer	Replace
		Incorrect valve or ignition transformer connections	Redo them
		Defective flame control	Replace
		A closed valve upstream the gas train	Open
	Air in pipework	Bleed air	
	Lockout with flame appearing	The GAS solenoid valve lets too little gas through	Increase
		Dirty flame sensor	Check, replace flame sensor
Faulty connection		Check, replace flame sensor	
Insufficient detection current (min.70 µA)		Measure current, replace flame sensor	
Flame sensor exhausted, faulty		Replace	
Maximum gas pressure switch intervention		Adjust or replace	
	The burner continues to repeat the start-up cycle without lockout	The gas pressure in the gas mains lies very close to the value to which the gas pressure switch has been set. The sudden drop in pressure after valve opening causes temporary opening of the pressure switch itself, the valve immediately closes and the burner stops. Pressure increases again, the pressure switch closes again and the ignition cycle is repeated. And so on.	Reduce the intervention pressure of the minimum gas pressure switch. Replace the gas filter cartridge
		Lockout without symbol indication	Flame simulation
	Burner goes into lockout during operation	Faulty flame sensor	Replace worn parts
		Air pressure switch faulty	Replace
◀	Lockout when the burner stops	Permanent flame in the combustion head or flame simulation	Eliminate permanency of flame or replace the flame control
	Ignition with pulsations	Poorly adjusted head	Adjust
		Ignition electrode incorrectly adjusted	Adjust it
		Incorrectly adjusted fan air damper: too much air	Adjust
		Output during ignition phase is too high	Reduce

Tab. Q

A Appendix - Accessories

Extended head Kit (for short head versions only)

Burner	L (mm)		Code
	Standard head	Head obtainable with the kit	
RLS 70	250	385	3010345
RLS 100	250	385	3010346
RLS 130	250	385	3010347

Soundproofing box kit

Burner	Type	dB(A)	Code
All models	C4/5	10	3010404

Degasser kit

Burner	Filter	Code
All models	with filter	3010055
All models	without filter	3010054

LPG kit

Burner	Code
All models	3010305

Maximum gas Pressure switch Kit

Burner	Code
All models	3010493

Ground fault interrupter kit

Burner	Code
All models	20098337

Seal control kit

Burner	Code	
	50 Hz	60 Hz
All models	3010123	20050030
	3010125	20050033

Gas trains in compliance with EN 676

Please refer to manual.



ATTENTION

The installer is responsible for the addition of any safety device not foreseen in this manual.

B Appendix - Electrical panel layout

1	Index of layouts
2	Indication of references
3	Operational layout
4	LFL1.333 operational layout
5	LFL1.333 operational layout
6	LFL1.333 operational layout
7	Electrical connection set by the installer

2 Indication of references

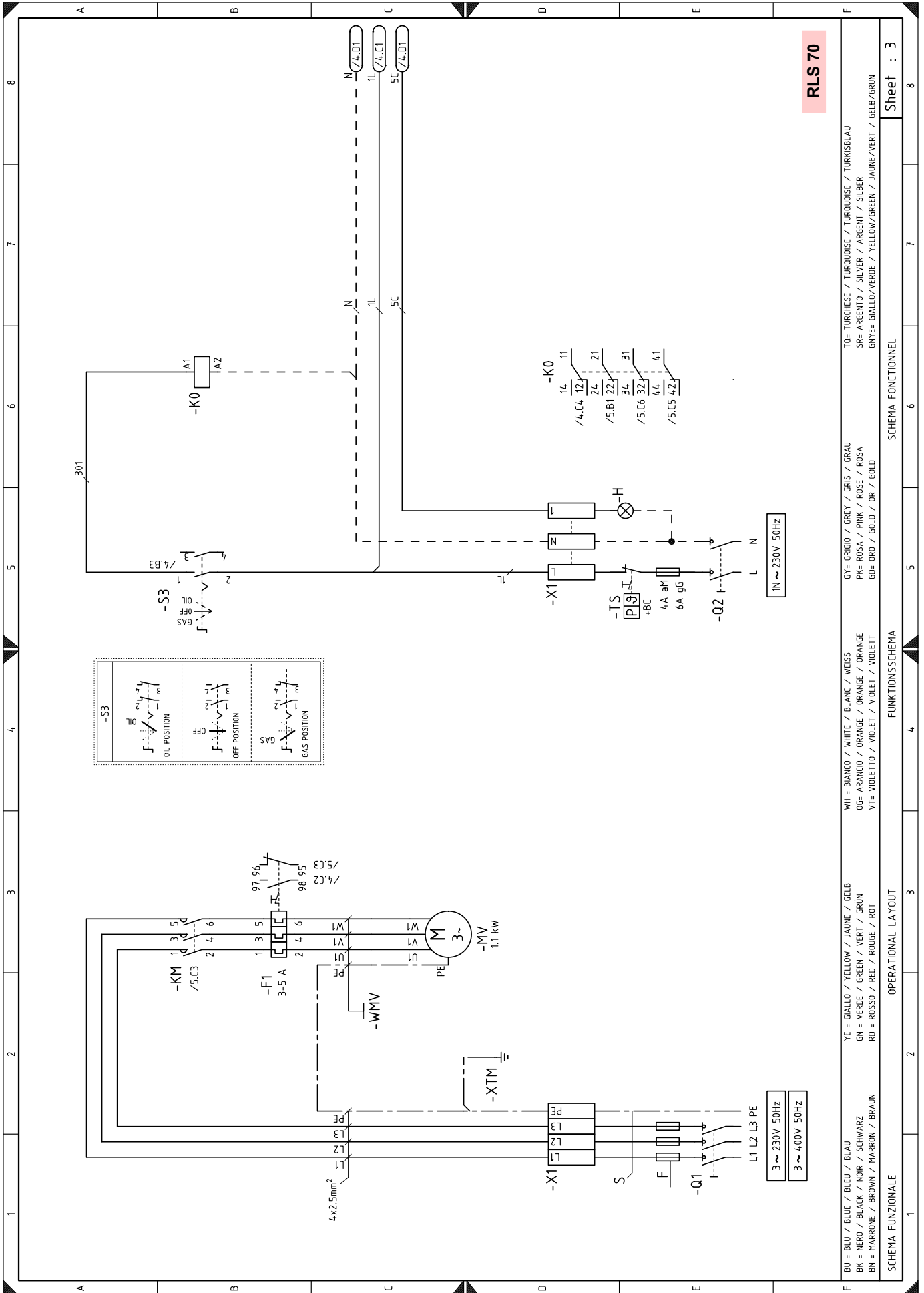

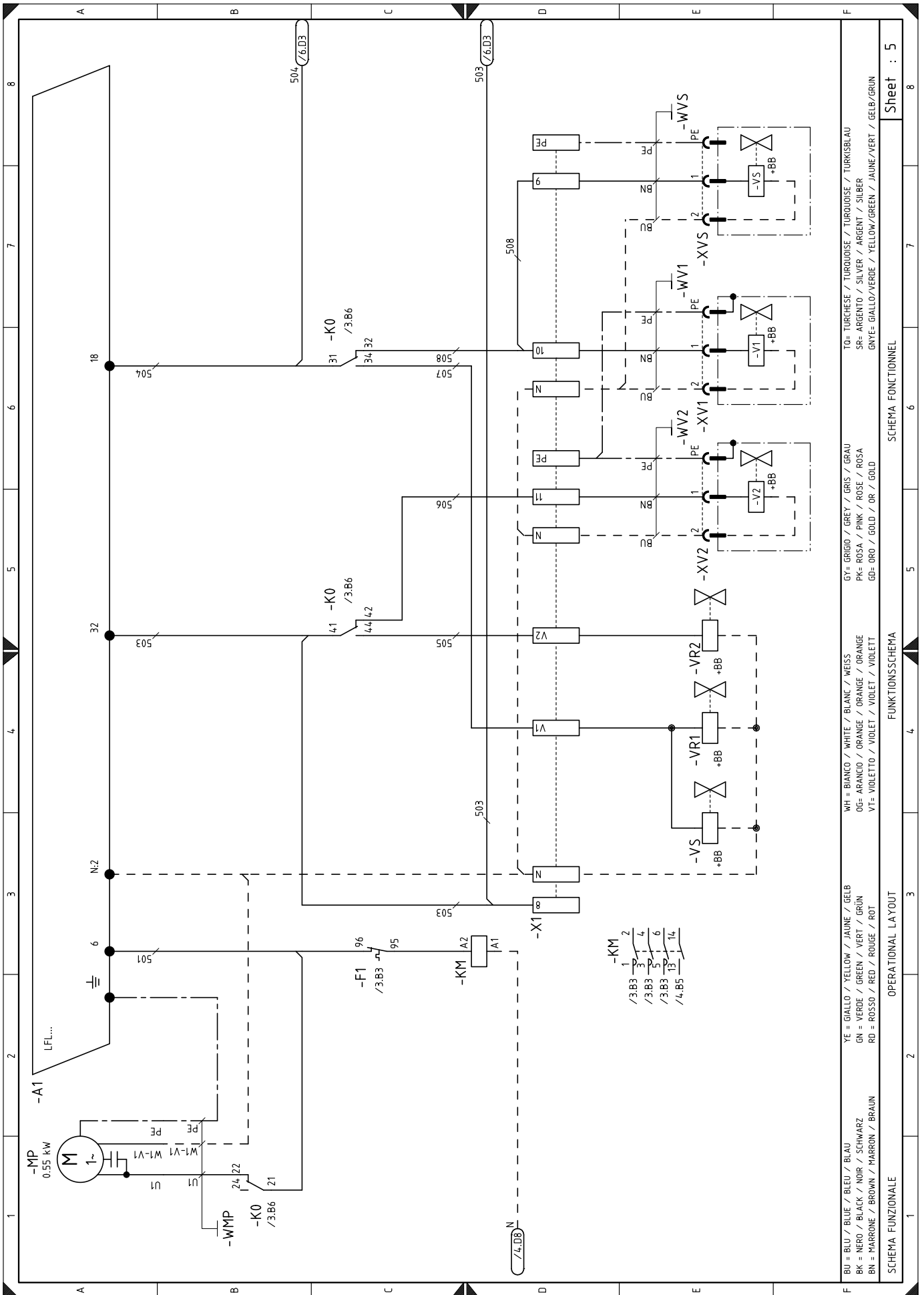

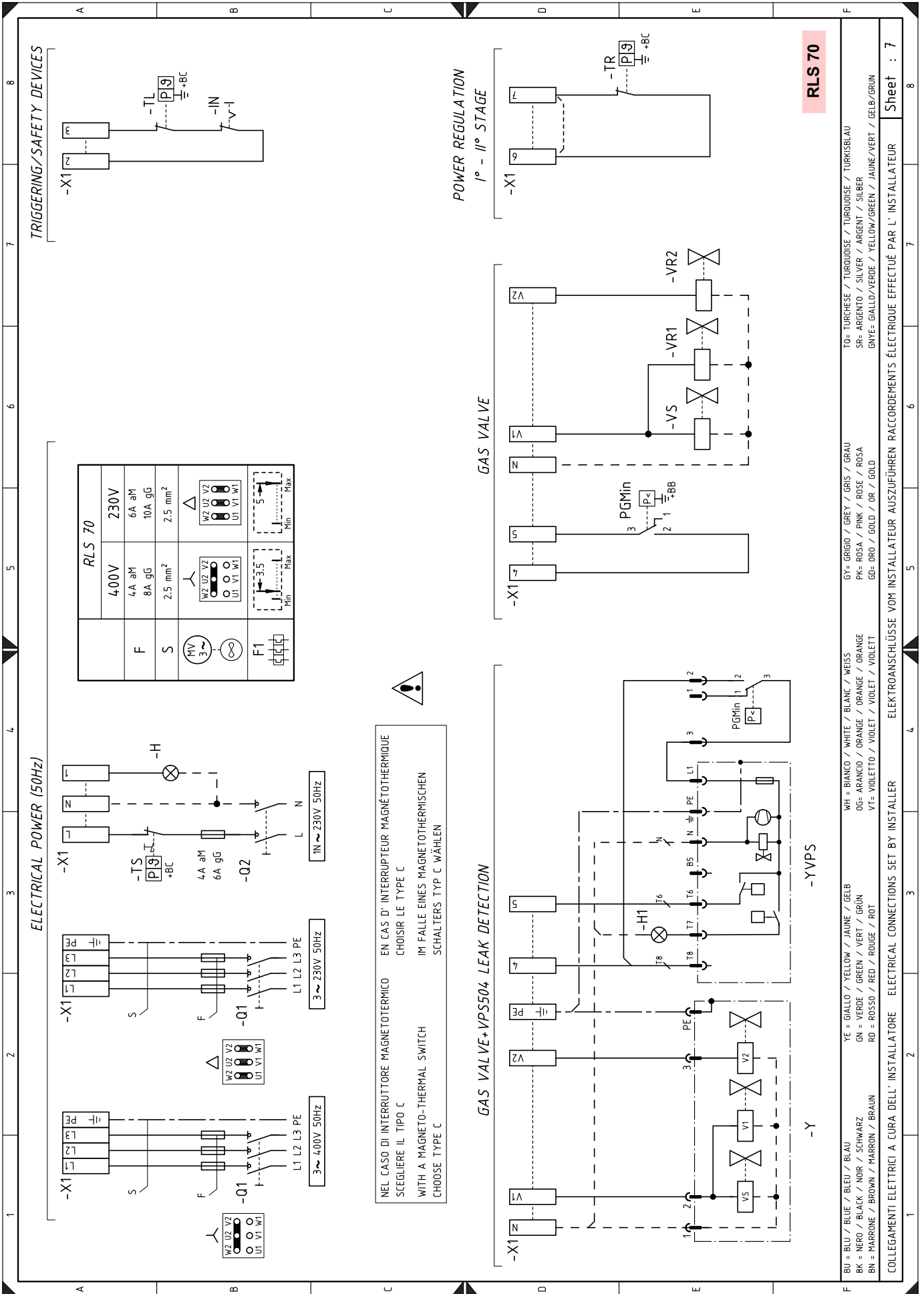

RLS 70

Sheet : 7

WIRING DIAGRAM KEY

A1	Flame control
F	Protection fuses for three line
F1	Thermal relay for fan motor
H	Remote lockout signal
H1	Light signalling leak detection control device lock-out
KM	Fan motor contactor
KO	Relay
K1	Relay
K2	Relay
IN	External switch for ON/OFF burner
MP	Pump motor
MV	Fan motor
PA	Air pressure switch
PGMin	Minimum gas pressure switch
Q1	Three-phase disconnecting switch
Q2	Single-phase disconnecting switch
SM	Servomotor
S1	ON - OFF switch
S2	1st- 2nd stage switch
S3	"Oil/OFF/Gas" selector
TA	Ignition transformer
TL	Limit thermostat
TR	Adjustment thermostat
TS	Safety thermostat
U	Led panel
UV	UV sensor
VS	Safety valve
V1	2nd stage valve
V2	Valvola 2° stadio
VR1	Adjustment valve
VR2	Adjustment valve
XV1	1st stage valve connector
XV2	2nd stage valve connector
XVS	Safety valve connector
XPE	Flame control earth
XTM	Burner earth
X1	Terminal board
Y	Gas adjustment valve + gas safety valve
YVPS	Leak detection control device

RIELLO

RIELLO S.p.A.
I-37045 Legnago (VR)
Tel.: +39.0442.630111
[http:// www.riello.it](http://www.riello.it)
[http:// www.riello.com](http://www.riello.com)