

**GB** **Forced draught gas burners**

Progressive two-stage or modulating operation

**CE**

**UK  
CA**

**EAC**

<b>CODE</b>	<b>MODEL</b>
20212532	RS 1000/M C01
20212531	RS 1200/M C01



**Translation of the original instructions**

<b>1</b>	<b>Information and general warnings.....</b>	<b>3</b>
1.1	Information about the instruction manual .....	3
1.1.1	Introduction.....	3
1.1.2	General dangers.....	3
1.1.3	Other symbols .....	3
1.1.4	Delivery of the system and the instruction manual .....	4
1.2	Guarantee and responsibility.....	4
<b>2</b>	<b>Safety and prevention.....</b>	<b>5</b>
2.1	Introduction.....	5
2.2	Personnel training .....	5
<b>3</b>	<b>Technical description of the burner .....</b>	<b>6</b>
3.1	Burner designation .....	6
3.2	Models available.....	6
3.3	Technical data .....	7
3.4	Electrical data.....	7
3.5	Burner categories - Countries of destination .....	7
3.6	Maximum dimensions.....	8
3.7	Firing rates .....	9
3.8	Test boiler.....	9
3.9	Burner description .....	10
3.10	Electrical panel description.....	11
3.11	Burner equipment.....	11
3.12	Flame control (LFL.....)	12
3.13	Servomotor SQM40 .....	13
<b>4</b>	<b>Installation .....</b>	<b>14</b>
4.1	Notes on safety for the installation .....	14
4.2	Handling .....	14
4.3	Preliminary checks .....	14
4.4	Operating position .....	15
4.5	Removal of the locking screws from the shutter.....	15
4.6	Preparing the boiler .....	15
4.6.1	Boring the boiler plate .....	15
4.6.2	Blast tube length.....	15
4.7	Securing the burner to the boiler .....	16
4.8	Access to head internal part.....	16
4.9	Electrode position.....	17
4.10	Combustion head adjustment.....	17
4.11	Gas feeding .....	18
4.11.1	Gas feeding line (Example) - Please refer to the gas train documentation for more information .....	18
4.11.2	Gas train .....	19
4.11.3	Gas train installation.....	19
4.11.4	Gas pressure.....	19
4.11.5	Pilot - gas train connection .....	20
4.11.6	Ignition pilot burner .....	20
4.12	Electrical wiring .....	21
4.12.1	Supply cables and external connections passage .....	21
4.13	Calibration of the thermal relay .....	22
4.14	Motor rotation .....	22
<b>5</b>	<b>Start-up, calibration and operation of the burner .....</b>	<b>23</b>
5.1	Notes on safety for the first start-up .....	23
5.2	Adjustments prior to ignition .....	23
5.3	Burner start-up .....	23

5.4	Burner ignition .....	24
5.5	Servomotor adjustment .....	24
5.6	Burner adjustment and output modulation .....	25
5.6.1	Maximum output .....	25
5.6.2	Minimum output .....	25
5.6.3	Intermediate outputs .....	25
5.7	Combustion air adjustment .....	26
5.8	Air / fuel adjustment .....	26
5.8.1	Burner calibration procedure .....	26
5.9	Pressure switch adjustment .....	27
5.9.1	Air pressure switch - check CO .....	27
5.9.2	Maximum gas pressure switch .....	27
5.9.3	Minimum gas pressure switch .....	27
5.10	Operation sequence of the burner .....	28
5.10.1	Burner start-up .....	28
5.10.2	Operation .....	28
5.10.3	Burner flame goes out during operation .....	28
5.10.4	Ignition failure .....	28
5.11	Final checks (with burner operating) .....	29
<b>6</b>	<b>Maintenance .....</b>	<b>30</b>
6.1	Notes on safety for the maintenance .....	30
6.2	Maintenance programme .....	30
6.2.1	Maintenance frequency .....	30
6.2.2	Safety test - with gas ball valve closed .....	30
6.2.3	Checking and cleaning .....	30
6.2.4	Safety components .....	31
6.3	Opening the burner .....	32
6.4	Closing the burner .....	32
<b>7</b>	<b>Faults - Possible causes - Solutions .....</b>	<b>33</b>
7.1	Gas operation .....	34
<b>A</b>	<b>Appendix - Accessories .....</b>	<b>36</b>
<b>B</b>	<b>Appendix - Electrical panel layout .....</b>	<b>37</b>

**1 Information and general warnings**

**1.1 Information about the instruction manual**

**1.1.1 Introduction**

The instruction manual supplied with the burner:

- is an integral and essential part of the product and must not be separated from it; it must therefore be kept carefully for any necessary consultation and must accompany the burner even if it is transferred to another owner or user, or to another system. If the manual is lost or damaged, another copy must be requested from the Technical Assistance Service of the area;
- is designed for use by qualified personnel;
- offers important indications and instructions relating to the installation safety, start-up, use and maintenance of the burner.

**Symbols used in the manual**

In some parts of the manual you will see triangular DANGER signs. Pay great attention to these, as they indicate a situation of potential danger.

**1.1.2 General dangers**

The **dangers** can be of **3 levels**, as indicated below.



Maximum danger level!  
This symbol indicates operations which, if not carried out correctly, cause serious injury, death or long-term health risks.



This symbol indicates operations which, if not carried out correctly, may cause serious injury, death or long-term health risks.



This symbol indicates operations which, if not carried out correctly, may cause damage to the machine and/or injury to people.

**1.1.3 Other symbols**



**DANGER: LIVE COMPONENTS**  
This symbol indicates operations which, if not carried out correctly, lead to electric shocks with lethal consequences.



**DANGER: FLAMMABLE MATERIAL**  
This symbol indicates the presence of flammable materials.



**DANGER: BURNING**  
This symbol indicates the risks of burns due to high temperatures.



**DANGER: CRUSHING OF LIMBS**  
This symbol indicates the presence of moving parts: danger of crushing of limbs.



**WARNING: MOVING PARTS**

This symbol indicates that you must keep limbs away from moving mechanical parts; danger of crushing.



**DANGER: EXPLOSION**

This symbol signals places where an explosive atmosphere may be present. An explosive atmosphere is defined as a mixture - under atmospheric conditions - of air and flammable substances in the form of gases, vapours, mist or dust in which, after ignition has occurred, combustion spreads to the entire unburned mixture.



**PERSONAL PROTECTION EQUIPMENT**

These symbols indicate the equipment that must be worn and kept by the operator for protection against threats against safety and/or health while at work.



**OBLIGATION TO ASSEMBLE THE HOOD AND ALL THE SAFETY AND PROTECTION DEVICES**

This symbol signals the obligation to reassemble the hood and all the safety and protection devices of the burner after any maintenance, cleaning or checking operations.



**ENVIRONMENTAL PROTECTION**

This symbol gives indications for the use of the machine with respect for the environment.



**IMPORTANT INFORMATION**

This symbol indicates important information that you must bear in mind.



This symbol indicates a list.

**Abbreviations used**

Ch.	Chapter
Fig.	Figure
Page	Page
Sec.	Section
Tab.	Table

**1.1.4 Delivery of the system and the instruction manual**

When the system is delivered, it is important that:

- the instruction manual is delivered to the user by the system manufacturer, with the recommendation to keep it in the room where the heat generator is to be installed.
- The instruction manual shows:
  - the serial number of the burner;

.....

- the address and telephone number of the nearest Assistance Centre;

.....  
 .....  
 .....

- The system supplier must carefully inform the user about:
  - the use of the system;
  - any further tests that may be required before activating the system;
  - maintenance, and the need to have the system checked at least once a year by a representative of the manufacturer or another specialised technician.
 To ensure a periodic check, the manufacturer recommends the drawing up of a Maintenance Contract.

**1.2 Guarantee and responsibility**

The manufacturer guarantees its new products from the installation date, in accordance with the regulations in force and/or the sales contract. At the moment of the first start-up, check that the burner is integral and complete.



**WARNING**

Failure to observe the information given in this manual, operating negligence, incorrect installation and carrying out of non authorised modifications will result in the annulment by the manufacturer of the guarantee that it supplies with the burner.

In particular, the rights to the guarantee and the responsibility will no longer be valid, in the event of damage to things or injury to people, if such damage/injury was due to any of the following causes:

- incorrect installation, start-up, use and maintenance of the burner;
- improper, incorrect or unreasonable use of the burner;
- intervention of unqualified personnel;
- carrying out of unauthorised modifications on the equipment;
- use of the burner with safety devices that are faulty, incorrectly applied and/or not working;
- installation of untested supplementary components on the burner;
- powering of the burner with unsuitable fuels;
- faults in the fuel supply system;
- use of the burner even following an error and/or an irregularity;
- repairs and/or overhauls incorrectly carried out;
- modification of the combustion chamber with inserts that prevent the regular development of the structurally established flame;
- insufficient and inappropriate surveillance and care of those burner components most likely to be subject to wear and tear;
- the use of non-original components, including spare parts, kits, accessories and optional;
- force majeure.

**The manufacturer furthermore declines any and every responsibility for the failure to observe the contents of this manual.**

**2 Safety and prevention**

**2.1 Introduction**

The burners have been designed and built in compliance with current regulations and directives, applying the known technical rules of safety and envisaging all the potential danger situations. It is necessary, however, to bear in mind that the imprudent and clumsy use of the equipment may lead to situations of death risk for the user or third parties, as well as the damaging of the burner or other items. Inattention, thoughtlessness and excessive confidence often cause accidents; the same applies to tiredness and sleepiness.

It is a good idea to remember the following:

- The burner must only be used as expressly described. Any other use should be considered improper and therefore dangerous.

In particular:

it can be applied to boilers operating with water, steam, diathermic oil, and to other users expressly named by the manufacturer; the type and pressure of the fuel, the voltage and frequency of the electrical power supply, the minimum and maximum deliveries for which the burner has been regulated, the pressurisation of the combustion chamber, the dimensions of the combustion chamber and the room temperature must all be within the values indicated in the instruction manual.

- Modification of the burner to alter its performance and destinations is not allowed.
- The burner must be used in exemplary technical safety conditions. Any disturbances that could compromise safety must be quickly eliminated.
- Opening or tampering with the burner components is not allowed, apart from the parts requiring maintenance.
- Only those parts envisaged by the manufacturer can be replaced.



The manufacturer guarantees safety and proper functioning only if all burner components are intact and positioned correctly.

**2.2 Personnel training**

The user is the person, body or company that has acquired the machine and intends to use it for the specific purpose. He is responsible for the machine and for the training of the people working around it.

The user:

- undertakes to entrust the machine exclusively to suitably trained and qualified personnel;
- undertakes to inform his personnel in a suitable way about the application and observance of the safety instructions. With that aim, he undertakes to ensure that everyone knows the use and safety instructions for his own duties;
- Personnel must observe all the danger and caution indications shown on the machine.
- Personnel must not carry out, on their own initiative, operations or interventions that are not within their province.
- Personnel must inform their superiors of every problem or dangerous situation that may arise.
- The assembly of parts of other makes, or any modifications, can alter the characteristics of the machine and hence compromise operating safety. The manufacturer therefore declines any and every responsibility for any damage that may be caused by the use of non-original parts.

In addition:



- the user must take all the measures necessary to prevent unauthorised people gaining access to the machine;
- the user must inform the manufacturer if faults or malfunctioning of the accident prevention systems are noticed, along with any presumed danger situation;
- Personnel must always use the personal protective equipment envisaged by legislation and follow the indications given in this manual.

**3 Technical description of the burner**

**3.1 Burner designation**

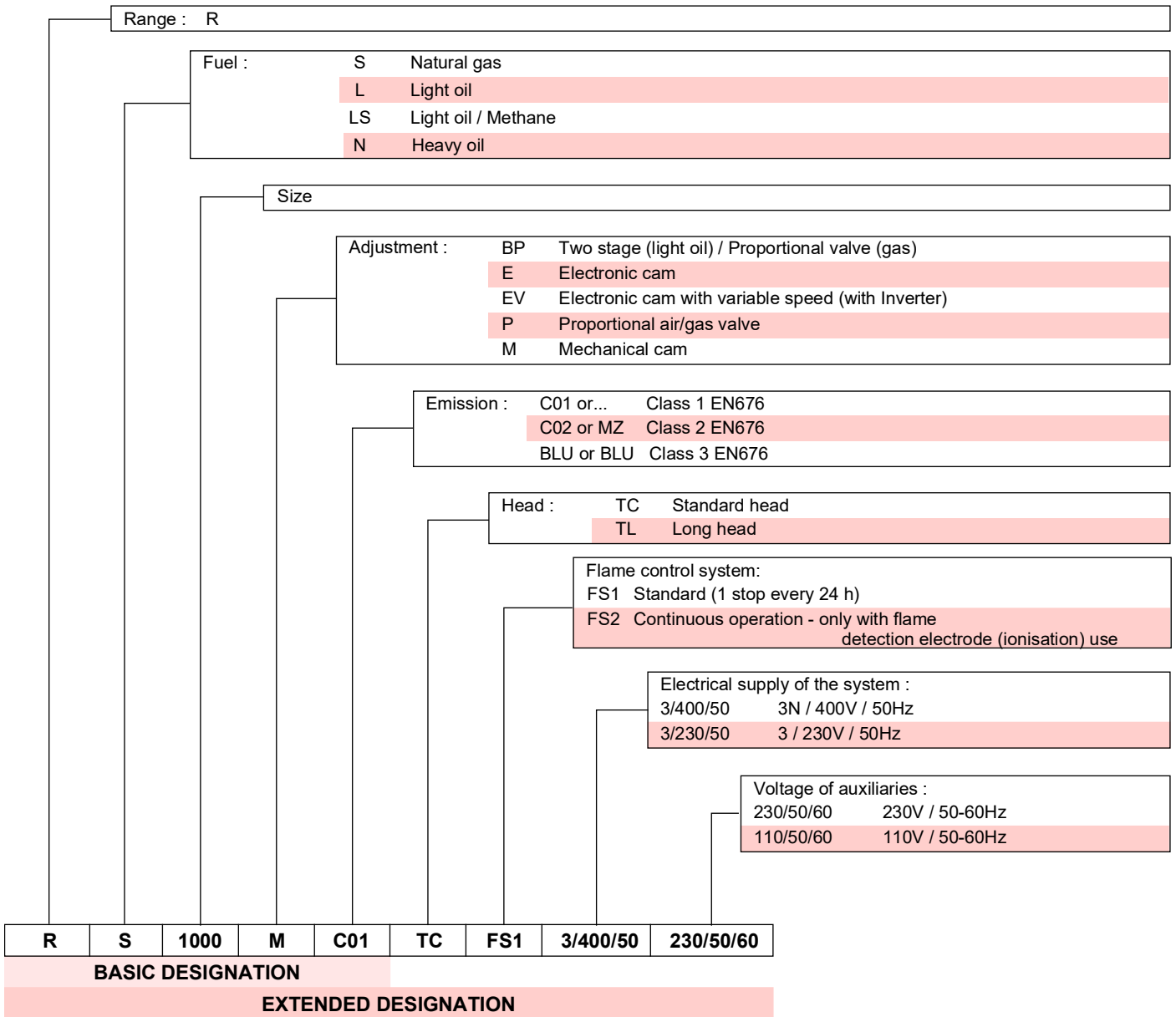

**3.2 Models available**

Designation		Voltage	Start-up	Code
RS 1000/M C01	TC	3N/400V/50Hz	Star/Triangle	20212532
RS 1200/M C01	TC	3N/400V/50Hz	Star/Triangle	20212531

Tab. A

### 3.3 Technical data

Model			RS 1000/M C01	RS 1200/M C01
Type			1139 T	1140 T
Output (1)	min - max	kW	1100/4000 - 10100	1500/5500 - 11100
Fuels			Natural gas: G20 (methane gas) - G25	
Operation			– Intermittent (min. 1 stop in 24 hours) – Progressive two-stage or modulating by kit (see accessories).	
Standard applications			Boilers: water, steam, diathermic oil	
Ambient temperature		°C	0 - 50	
Combustion air temperature		°C max	60	
Noise levels (2)	Sound pressure	dB(A)	85	89.3
	Sound power		99	99.7
Weight		Kg	460	500
CE			CE - 0476DP3335	

**Tab. B**

- (1) Reference conditions: Ambient temperature 20°C - Gas temperature 15°C - Barometric pressure 1013 mbar - Altitude 0 m a.s.l.  
 (2) Sound pressure measured in manufacturer's combustion laboratory, with burner operating on test boiler and at maximum rated output. The sound power is measured with the "Free Field" method, as per EN 15036, and according to an "Accuracy: Category 3" measuring accuracy, as set out in EN ISO 3746.

### 3.4 Electrical data

Model			RS 1000/M C01	RS 1200/M C01
Electrical supply		3N~ 400V ± 10% 50 Hz		
Absorbed electrical power		kW max	25	28
Protection level			IP 55	

**Tab. C**

### 3.5 Burner categories - Countries of destination

Country of destination	Gas category
AT - BG - CH - CZ - DK - EE - ES - FI - GB - GR - HU - IE - IS - IT - LT - LV - NO - PT - RO - SE - SI - SK - TR	I <sub>2</sub> H
DE	I <sub>2</sub> ELL
NL	I <sub>2</sub> EK
FR	I <sub>2</sub> E <sub>r</sub>
BE	I <sub>2</sub> E(R)
LU - PL	I <sub>2</sub> E

**Tab. D**

**3.6 Maximum dimensions**

The maximum dimensions of the burner are shown in Fig. 1. Bear in mind that inspection of the combustion head requires the burner to be opened and the rear part turned on the hinge.

The maximum dimensions of the open burner are indicated by the L and R positions.

The I position is reference for the refractory thickness of the boiler door.

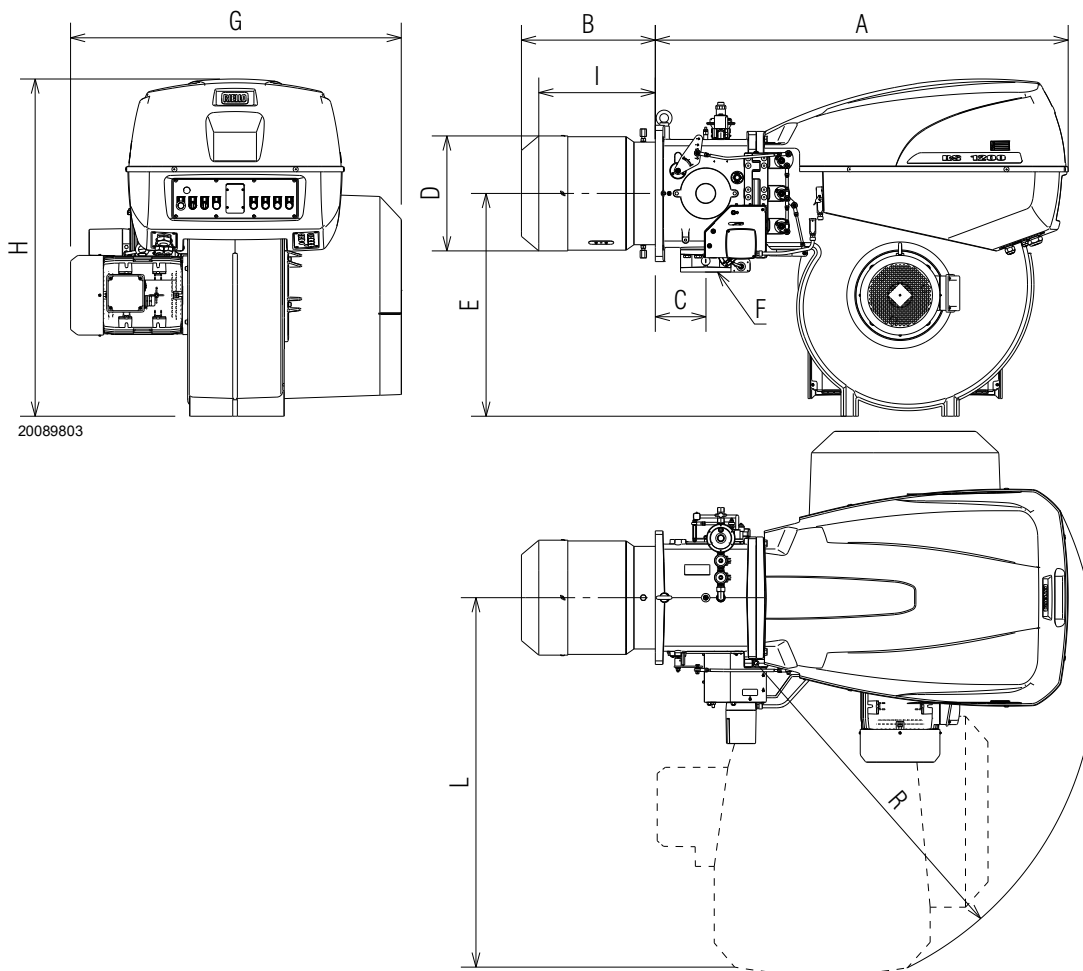

**Fig. 1**

mm	A	B	C	D	E	F	G	H	I	L	R
RS 1000/M C01	1637	538	200	413	885	DN80	1206	1338	485	1493	1350
RS 1200/M C01	1637	539	200	456	885	DN80	1250	1338	485	1493	1350

**Tab. E**

**3.7 Firing rates**

The **MAXIMUM OUTPUT** is chosen from within the continuous diagram area (Fig. 2).

The **MINIMUM OUTPUT** must not be lower than the minimum limit of the diagram:

RS 1000/M C01 = 4000 kW  
 RS 1200/M C01 = 5500 kW



The firing rate value (Fig. 2) has been obtained considering an ambient temperature of 20 °C, an atmospheric pressure of 1013 mbar (approx. 0 m a.s.l.), and with the combustion head adjusted as shown on page 17.

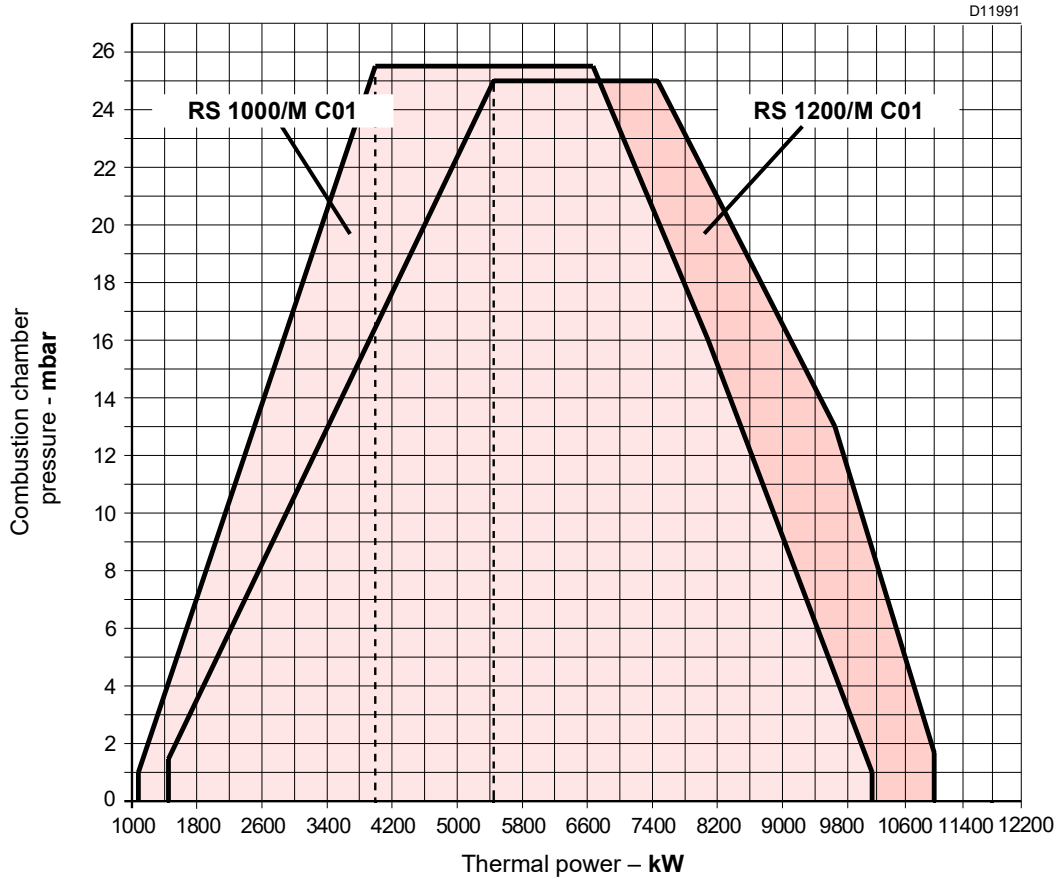

**Fig. 2**

**3.8 Test boiler**

The burner/boiler combination does not pose any problems if the boiler is EC approved and its combustion chamber dimensions are similar to those indicated in the diagram (Fig. 3).

If the burner must be combined with a boiler that has not been EC approved and/or its combustion chamber dimensions are clearly smaller than those indicated in the diagram, consult the manufacturer.

The firing rates were obtained in special test boilers, according to EN 676 regulations.

In Fig. 3 you can see the diameter and length of the test combustion chamber.

**Example:**  
 Output 7000 kW - diameter 120 cm - length 6 m.

**MODULATING RATIO**

The modulating ratio, obtained in test boilers in accordance with standard EN 676, is 2.5:1.

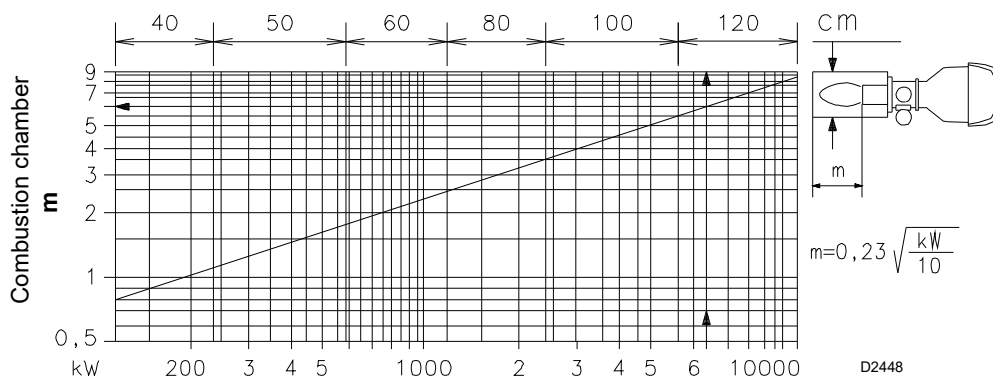

**Fig. 3**

3.9 Burner description

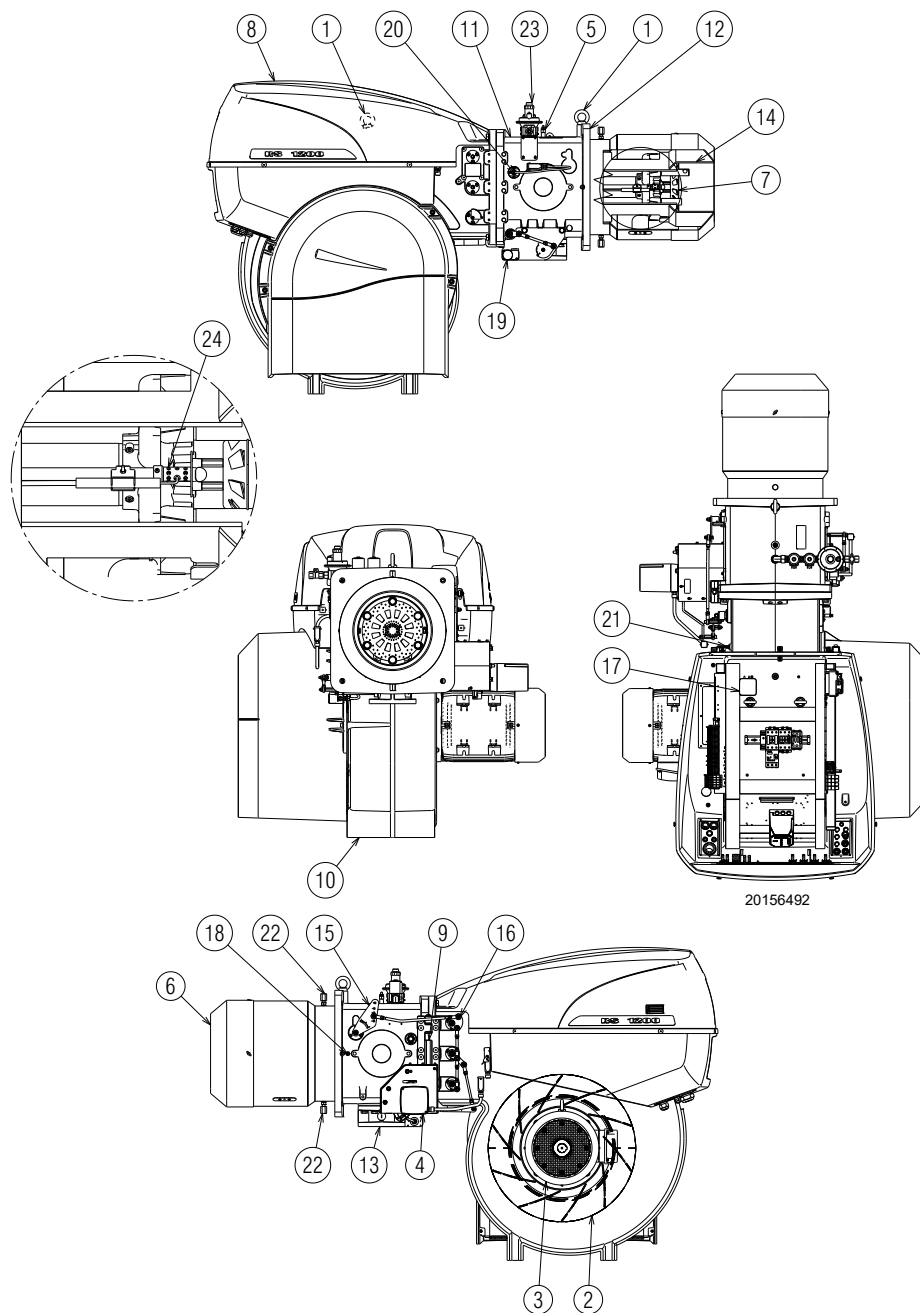
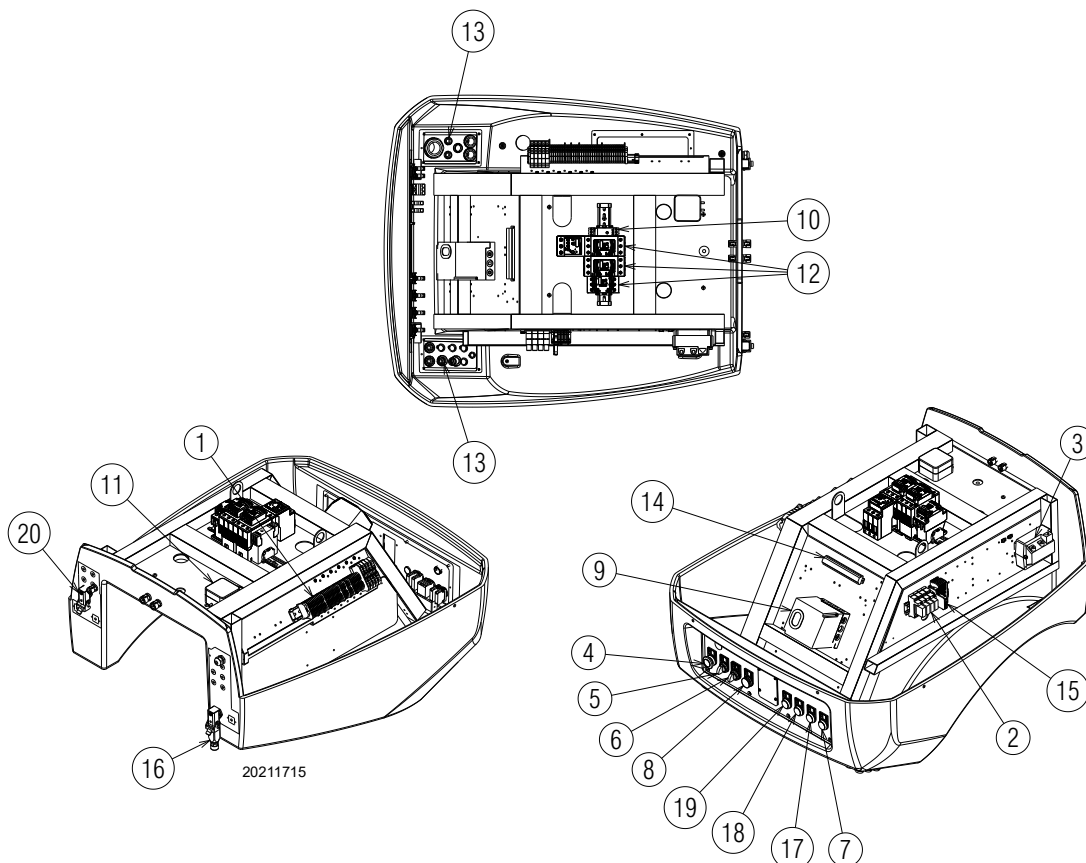

Fig. 4

- |  |   |
|--|---|
| <ul style="list-style-type: none"> <li>1 Lifting rings</li> <li>2 Fan</li> <li>3 Fan motor</li> <li>4 Servomotor</li> <li>5 Combustion head gas pressure test point</li> <li>6 Combustion head</li> <li>7 Flame stability disc</li> <li>8 Electrical panel casing</li> <li>9 Hinge for opening the burner</li> <li>10 Fan air inlet</li> <li>11 Pipe coupling</li> <li>12 Gasket for boiler fixing</li> <li>13 Gas train flange</li> </ul> | <ul style="list-style-type: none"> <li>14 Shutter</li> <li>15 Combustion head movement lever</li> <li>16 Air damper movement leverage</li> <li>17 Air pressure switch (differential operating type)</li> <li>18 Combustion head air pressure test point</li> <li>19 Maximum gas pressure switch with pressure test point</li> <li>20 Flame sensor</li> <li>21 Pressure test point for air pressure switch “+”</li> <li>22 Locking screws of the shutter during the transport (replace them with the screws M12x25 supplied with the burner)</li> <li>23 Pilot gas train</li> <li>24 Ignition pilot</li> </ul> |
|--|---|

**3.10 Electrical panel description**



**Fig. 5**

- 1 Main terminal supply board
- 2 Clean contacts output relay
- 3 Ignition transformer
- 4 Stop push-button
- 5 OFF-automatic-manual selector
- 6 Power increase - power reduction selector
- 7 Light signalling of motor - fan thermal relay operation
- 8 Light signalling of burner lockout and reset switch
- 9 Flame control
- 10 Timer
- 11 Air pressure switch
- 12 Fan motor contactor and thermal relay, star-triangle starter
- 13 Supply cables, external connections and kits
- 14 Terminal board for kit RWF50
- 15 Auxiliary circuits fuse

- 16 Plug/socket servomotor
- 17 Light signalling of main fuel valve open
- 18 Heat request light signalling
- 19 Light signalling of mains live state
- 20 Flame sensor plug/sensor socket

**NOTE**

Two types of burner lockout may occur:

- **Flame control lockout:** if the pushbutton of the flame control 9)(Fig. 5) and the pushbutton with light 8) light up, this indicates that the burner is in lockout. Release by pressing the pushbutton 8).
- **Motors lockout:** release by pressing the button on the relevant thermal relay.

**3.11 Burner equipment**

Gasket for gas train flange . . . . .	No. 1
Thermal insulation screen . . . . .	No. 1
Screws M12x25 . . . . .	No. 2
Gas flange fixing screws M16x70. . . . .	No. 8
Screws M20x70 to secure the burner flange to the boiler . .	No. 4
Instructions . . . . .	No. 1
Spare parts list . . . . .	No. 1



It is recommended to tighten the screws of the gas flange with a tightening torque of:

- (DN80) **40 Nm** ±10%;
- (DN100) **50 Nm** ±10%;
- (DN125) **60 Nm** ±10%.

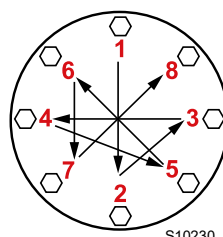

Tighten the nuts gradually (first to 30%, then to 60% up to 100%) according to the cross pattern shown in the figure.

**3.12 Flame control (LFL...)**

**Important notes**



To avoid accidents, material or environmental damage, observe the following instructions!

The flame control LFL... is a safety device! Avoid opening or modifying it, or forcing its operation. Riello S.p.A. cannot assume any responsibility for damage resulting from unauthorised interventions!

- All interventions (assembly and installation operations, assistance, etc.) must be carried out by qualified personnel.
- Before modifying the wiring in the LFL... flame control connection area, fully disconnect the system from the power supply (omnipolar separation).
- Protection against electrocution from the flame control and all connected electric components is obtained with the correct assembly.
- Before any intervention (assembly and installation operations, assistance, etc.), ensure the wiring is in order and that the parameters are correctly set, then make the safety checks.
- Falls and collisions can negatively affect the safety functions. In this case, the flame control must not be operated, even if it displays no evident damage.
- **Do not press the reset button or the remote reset button of the flame control for more than 10 seconds because this will damage the internal relay.**

For safety and reliability, comply with the following instructions:

- Avoid conditions that can favour the development of condensate and humidity. Otherwise, before switching on again, make sure that the entire flame control is perfectly dry!
- Static charges must be avoided since they can damage the flame control's electronic components when touched.

**Use**

The LFL... flame control is a control and supervision system of medium and large capacity forced draft burners for intermittent operation (at least one controlled shutdown every 24 hours).

**Installation notes**

- Check the electrical wiring inside the boiler complies with the national and local safety regulations.
- Do not confuse the powered conductors with the neutral ones.
- Ensure that spliced wires cannot get into contact with neighbouring terminals. Use adequate ferrules.
- Arrange the H.V. ignition cables separately, as far as possible from the flame control and the other cables.
- When wiring the unit, make sure that AC 230 V mains voltage cables are run strictly separate from extra low-voltage cables to avoid risks of electrical shock hazard.

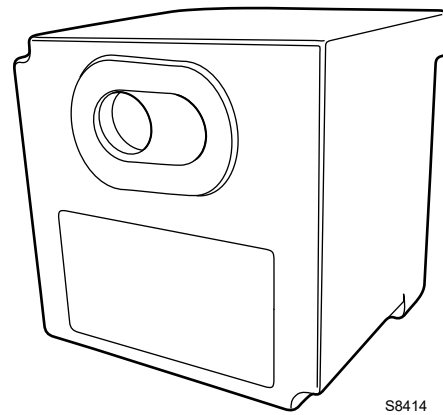

**Fig. 6**

**Electrical wiring of the flame detector**

It is important for signal transmission to be almost totally free of any disturbances or loss:

- Always separate the detector cables from the other cables:
  - The capacitive reactance of the line reduces the size of the flame signal.
  - Use a separate cable.
- Respect the allowed cable lengths.
- The ionisation probe is not protected against the risk of electrocution. When connected to the electricity supply, the ionisation probe must be protected against any accidental contact.
- Position the ignition electrode and the ionisation probe so that the ignition spark cannot form an arc on the probe (risk of electric overcharge).

**Technical data**

Mains voltage	AC 230 V -15 % / +10 %
Mains frequency	50 / 60 Hz ±6 %
Fuse (Internal)	T6.3H250V
Primary fuse (external)	max. 10 A
Weight	approx. 1 kg
Power absorption	approx. AC 3.5 VA
Protection level	IP40
Safety class	II
Input current at terminal 1	max. 5 A continuous (peaks of 20 A / 20 ms)
Load on the control terminals	max. 4 A continuous (peaks of 20 A / 20 ms)
<b>Environmental conditions</b>	
Operation	DIN EN 60721-3-1
Climatic conditions	Class 1K3
Mechanical conditions	Class 1M2
Temperature range	-20...+60°C
Humidity	< 95% RH

**Tab. F**

3.13 Servomotor SQM40 ...

**Important notes**



To avoid accidents, material or environmental damage, observe the following instructions!  
 Avoid opening, modifying or forcing the servomotor.

- All interventions (assembly and installation operations, assistance, etc.) must be carried out by qualified personnel.
- Falls and collisions can negatively affect the safety functions. In this case, the servomotor must not be operated, even if it displays no evident damage.
- Fully disconnect the burner from the mains when working near terminals and servomotor connections.
- Condensation and exposure to water are not allowed.
- For safety reasons, the servomotor must be checked after long periods of non-use.



**Fig. 7**

**Technical data**

Mains voltage	230 V -15% +10%
Mains frequency	50 / 60 Hz
Power absorption	10 VA
Motor	Synchronous
Drive angle	Varying between 0° and 135°
Protection level	Max. IP 66, with appropriate cable entry
Cable entry	2 x M20
Cable connection	terminal board for 0.5mm <sup>2</sup> (min.) and 2.5mm <sup>2</sup> (max.)
Rotation direction	Anticlockwise
Rated torque (max.)	10 Nm
Holding torque	5 Nm
Operation time	30 s. at 90°
Weight	approx. 2 kg
Environmental conditions:	
Operation	-20...+60° C
Transport and storage	-20...+60°C

**Tab. G**

**4 Installation**

**4.1 Notes on safety for the installation**

After carefully cleaning all around the area where the burner will be installed, and arranging the correct lighting of the environment, proceed with the installation operations.



All the installation, maintenance and disassembly operations must be carried out with the electricity supply disconnected.



The installation of the burner must be carried out by qualified personnel, as indicated in this manual and in compliance with the standards and regulations of the laws in force.



Combustion air inside the boiler must be free from hazardous mixes (e.g.: chloride, fluoride, halogen); if present, it is highly recommended to carry out cleaning and maintenance more frequently.

**4.2 Handling**

The packaging of the burner includes a wooden platform, so it is possible to move the burner (still packaged) with a transpallet truck or fork lift truck.



The handling operations for the burner can be highly dangerous if not carried out with the greatest attention: keep any unauthorised people at a distance; check the integrity and suitability of the available means of handling. Check also that the area in which you are working is empty and that there is an adequate escape area (i.e. a free, safe area to which you can quickly move if the burner should fall). When handling, keep the load at not more than 20-25 cm from the ground.



After positioning the burner near the installation point, correctly dispose of all residual packaging, separating the various types of material.



Before proceeding with the installation operations, carefully clean all around the area where the burner will be installed.

**4.3 Preliminary checks**

**Checking the consignment**



After removing all the packaging, check the integrity of the contents. In the event of doubt, do not use the burner; contact the supplier.



The packaging elements (wooden cage or cardboard box, nails, clips, plastic bags, etc.) must not be abandoned as they are potential sources of danger and pollution; they should be collected and disposed of in the appropriate places.

20187902

		A		B	
		D		C	
		E		F	
GAS-KAASU	<input checked="" type="checkbox"/>	FAM.2		G	
GAZ-AEPIO	<input type="checkbox"/>	FAM.3		H	
		G		H	
I	I	I	I	I	I
				CE	
					

**Fig. 8**

**Checking the characteristics of the burner**

Check the identification label of the burner (Fig. 8), showing:

- A the burner model;
  - B the burner type;
  - C the cryptographic year of manufacture;
  - D the serial number;
  - E the data for electrical supply and the protection level;
  - F the electrical power consumption;
  - G the types of gas used and the relative supply pressures;
  - H the data of the burner's minimum and maximum output possibilities (see Firing rate).
- Warning.** The burner output must be within the boiler's firing rate;
- I the category of the appliance/countries of destination.



A burner label, or any other component, that has been tampered with, removed or is missing, prevents the definite identification of the burner and makes any installation or maintenance work difficult.

**4.4 Operating position**



- The burner is designed to operate only in positions 1 and 4 (Fig. 9).
- Installation 1 is preferable, as it is the only one that allows the maintenance operations as described in this manual.
- Installations 2, 3 and 4 permit operation but make maintenance and inspection of the combustion head more difficult.



- Any other position could compromise the correct operation of the appliance.
- Installation 5 is prohibited for safety reasons.

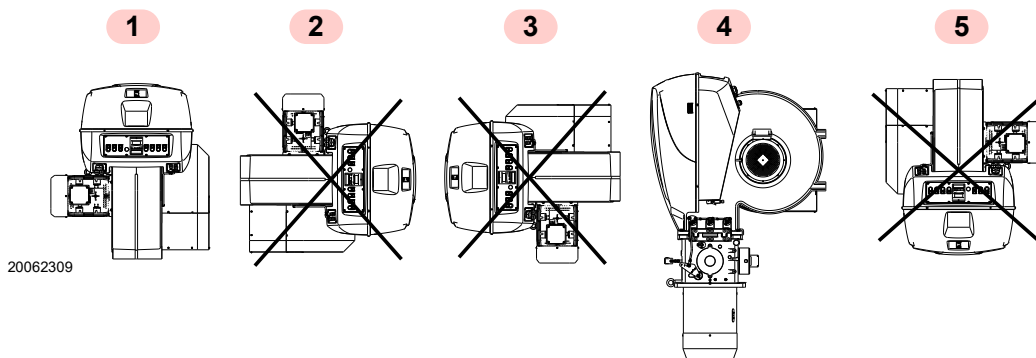

Fig. 9

**4.5 Removal of the locking screws from the shutter**



Remove the screws and the nuts 1)- 2)(Fig. 10), before installing the burner on the boiler.  
Replace them with the screws 3) M12x25 supplied with the burner.

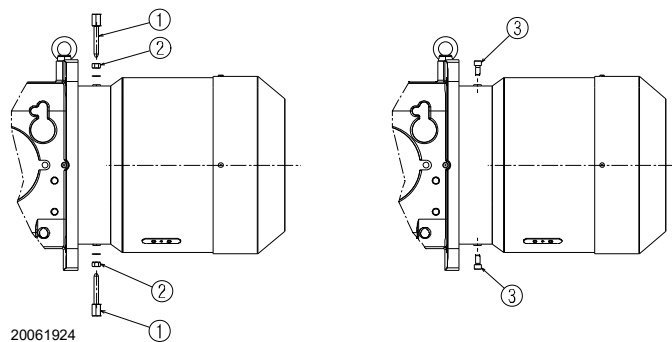

Fig. 10

**4.6 Preparing the boiler**

**4.6.1 Boring the boiler plate**

Pierce the closing plate of the combustion chamber, as in Fig. 11.  
The position of the threaded holes can be marked using the thermal insulation screen supplied with the burner.

**4.6.2 Blast tube length**

The length of the blast tube must be selected according to the indications provided by the manufacturer of the boiler, and in any case it must be greater than the thickness of the boiler door complete with its refractory.

For boilers with front flue passes 1)(Fig. 12) or flame inversion chamber, a protection in refractory material 5) must be inserted between the boiler fettleing 2) and the blast tube 4).

This protection must not compromise the extraction of the blast tube.

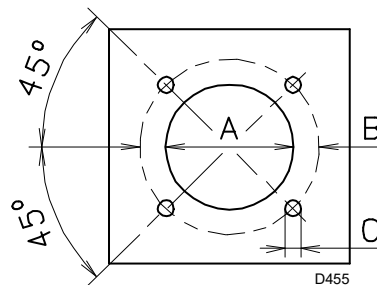

Fig. 11

mm	A	B	C
RS 1000/M C01	460	608	M 20
RS 1200/M C01	500	608	M 20

Tab. H

### 4.7 Securing the burner to the boiler



Prepare a suitable lifting system using rings 3)(Fig. 12).



The seal between burner and boiler must be airtight.

- Insert the thermal protection supplied with the blast tube 4).
- Insert the entire burner on the boiler hole, previously fitted, as in Fig. 11 on page 15, and fix it with the screws supplied.

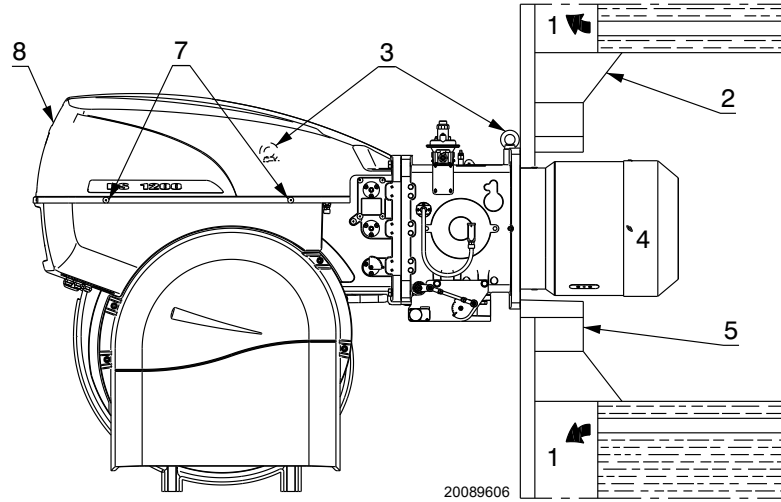

Fig. 12

### 4.8 Access to head internal part

In order to reach inside the combustion head (Fig. 13) proceed as follows:

- disconnect the electrical wiring from the servomotor;
- disconnect the leverage 3) of the cam and movement of the head 12);
- unscrew the 4 fixing screws 1) and open the burner on the hinge;
- disconnect the cables 14) from the electrodes 2);
- remove the screw/gas pressure socket 6) of the head;
- pull out the inner part of the head 5).

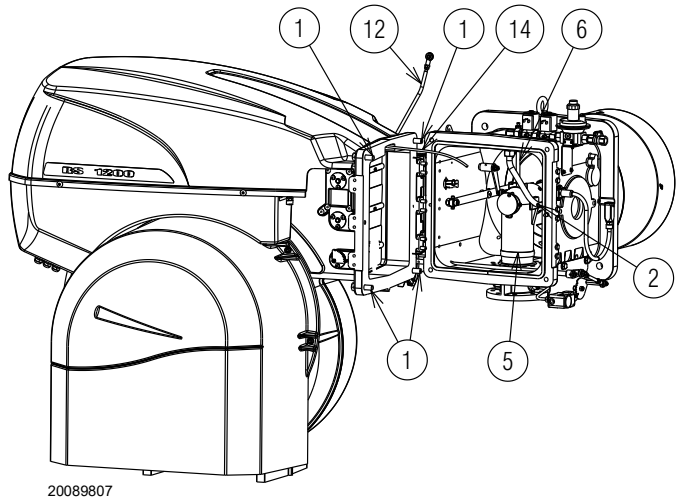

Fig. 13

**4.9 Electrode position**



Place the electrode on the ignition pilot observing the dimensions specified in Fig. 14.

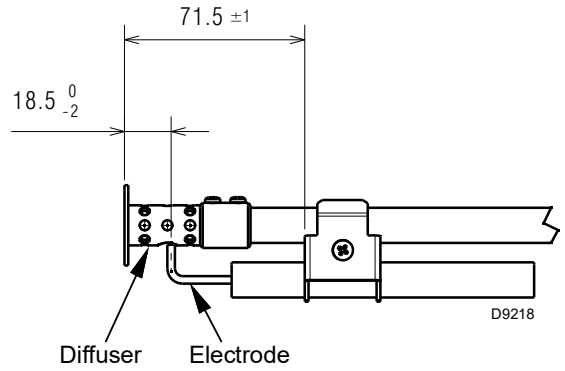

Fig. 14

**4.10 Combustion head adjustment**

The air damper servomotor 4)(Fig. 4 on page 10), beyond varying the air output according to the output demand, through a leverage varies the combustion head adjustment.

This system allows an optimum adjustment also at minimum firing rate. Similarly to servomotor rotation, it is possible to vary the opening of the combustion head moving the tie-rod on the holes (5-6-7-8-10)(Fig. 15).

The selection of the hole to be used is determined based on the maximum output requested, as illustrated in Tab. I.

In the factory, the adjustment is adjusted for the maximum stroke (hole 10, Fig. 15).

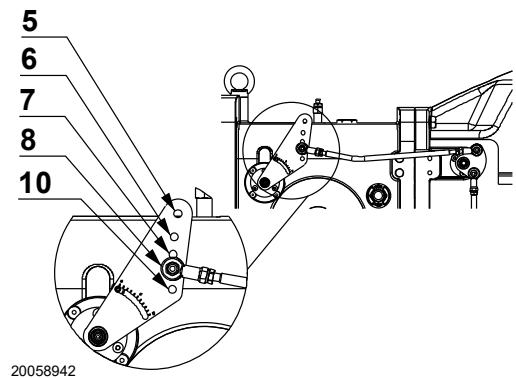

Fig. 15

	Leverage hole	Output (kW)	
		From	A
RS 1000	5	1100	4000
	5	4000	6600
	6	6600	8100
	8	8100	10100
RS 1200	5	1500	5500
	6	5500	7500
	8	7500	9650
	10	9650	11100

Tab. I

**4.11 Gas feeding**



Explosion danger due to fuel leaks in the presence of a flammable source.

Precautions: avoid knocking, attrition, sparks and heat.

Make sure that the fuel interception tap is closed before performing any operation on the burner.



The fuel supply line must be installed by qualified personnel, in compliance with current standards and laws.

**4.11.1 Gas feeding line (Example) - Please refer to the gas train documentation for more information**

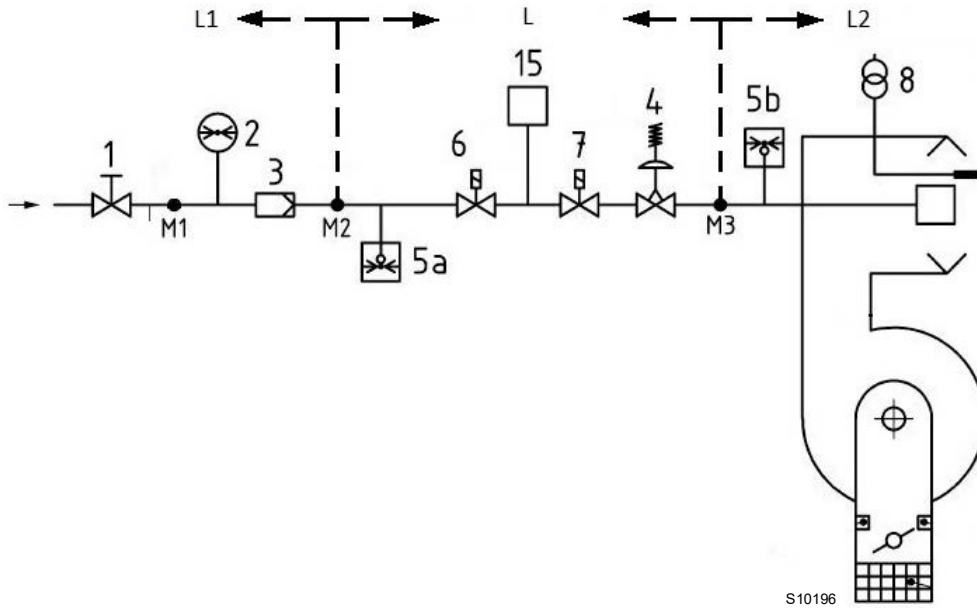

**Fig. 16**

Key (Fig. 16)

- 1 Manually operated shut-off valve
- 2 Pressure gauge
- 3 Filter
- 4 Governor
- 5a Low pressure protection device
- 5b Maximum gas pressure switch
- 6 1st safety shut-off device
- 7 2nd safety shut-off device
- 8 Ignition device
- 15 Valve leak detection control system
- L Gas train (supplied separately)
- L1 Responsibility of the installer
- L2 Burner
- M1 Pressure test point
- M2 Pressure test point
- M3 Pressure test point

**4.11.2 Gas train**

Type-approved in accordance with EN 676 and supplied separately from the burner.

**4.11.3 Gas train installation**



Disconnect the electrical supply by means of the system's main switch.



Make sure that there are no gas leaks.



Pay attention when handling the train: danger of crushing of limbs.



Make sure that the gas train is properly installed by checking for any fuel leaks.



The operator must use the required equipment during installation.

The gas train is prearranged to be connected to the burner with the flange 1)(Fig. 17).

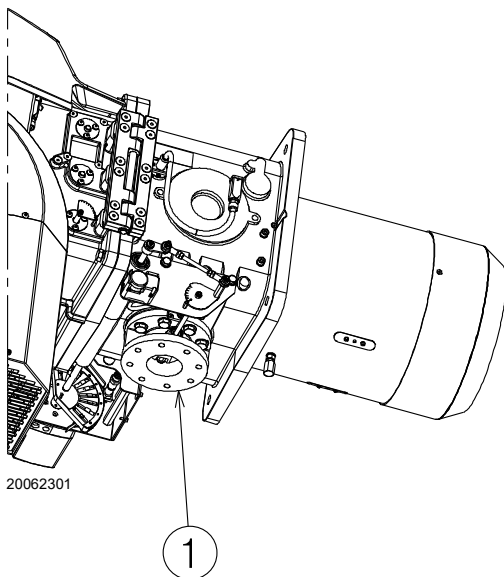

**Fig. 17**



The heat output and gas pressure data in the head refer to operation with gas butterfly valve fully open (90°).

**4.11.4 Gas pressure**

Tab. J indicates the pressure drop of the combustion head and the gas butterfly valve depending on the operating output of the burner.

	kW	1 Δp (mbar)		2 Δp (mbar)	
		G 20	G 25	G 20	G 25
RS 1000/M C01	4000	9.9	14.4	1.2	1.7
	4500	13.0	18.8	1.5	2.2
	5000	16.0	23.2	1.8	2.7
	5500	19.1	27.6	2.2	3.3
	6000	22.1	32.0	2.6	3.9
	6500	25.2	36.3	3.1	4.6
	7000	28.9	41.6	3.6	5.3
	7500	32.9	47.2	4.1	6.1
	8000	36.9	52.7	4.7	7.0
	8500	41.5	59.4	5.3	7.9
	9000	46.4	66.3	5.9	8.8
RS 1200/M C01	9500	51.2	73.3	6.6	9.8
	10000	56.0	80.2	7.3	10.9
	10100	57.0	81.6	7.5	11.1
	5500	18.2	26.6	2.2	3.3
	6000	22.1	32.1	2.6	3.9
	6500	26.0	37.6	3.1	4.6
	7000	29.9	43.2	3.6	5.3
	7500	33.8	48.7	4.1	6.1
	8000	38.6	55.4	4.7	7.0
	8500	43.4	62.1	5.3	7.9
	9000	48.2	68.8	6.0	8.8
9500	53.1	75.5	6.6	9.8	
10000	58.6	83.1	7.4	10.9	
10500	64.4	91.0	8.1	12.0	
11000	70.2	99.0	8.9	13.2	
11100	71.4	100.6	9.1	13.4	

**Tab. J**

The values shown in Tab. J refer to:

- Natural gas G 20 NCV 9.45 kWh/Sm<sup>3</sup> (8.2 Mcal/Sm<sup>3</sup>)
- Natural gas G 25 NCV 8.13 kWh/Sm<sup>3</sup> (7.0 Mcal/Sm<sup>3</sup>)

Column 1

Pressure drop on combustion head.

Gas pressure measured at the test point 1)(Fig. 18 on page 20), with:

- combustion chamber at 0 mbar;
- burner working at maximum modulating output;
- combustion head adjusted as in page 17.

Column 2

Pressure loss at gas butterfly valve 2)(Fig. 18 on page 20) with maximum opening: 90°.

To calculate the approximate output at which the burner operates:

- Subtract the combustion chamber pressure from the gas pressure measured at test point 1)(Fig. 18 on page 20).
- Find, in the table Tab. J related to the burner concerned, the pressure value closest to the result of the subtraction.
- Read off the corresponding output on the left.

### Example RS 1000/M C01 with natural gas G20:

Maximum modulating output operation  
 Gas pressure at test point 1) (Fig. 18) = 41.9 mbar  
 Pressure in combustion chamber = 5 mbar  
 $41.9 - 5 = 36.9$  mbar

A pressure of 36.9 mbar, column 1, corresponds in the table Tab. J on page 19 to an output of 8000 kW.

This value serves as a rough guide; the effective output must be measured at the gas meter.

To calculate the required gas pressure at test point 1)(Fig. 18), set the maximum modulating output required from the burner operation:

- find the nearest output value in the table Tab. J for the burner in question.
- Read, on the right (column 1), the pressure at the test point 1)(Fig. 18).
- Add this value to the estimated pressure in the combustion chamber.

### Example RS 1000/M C01 with natural gas G20:

Maximum modulating output operation  
 Gas pressure at an output of 8000 kW = 36.9 mbar  
 Pressure in combustion chamber = 5 mbar  
 $36.9 + 5 = 41.9$  mbar

Pressure required at test point 1)(Fig. 18).

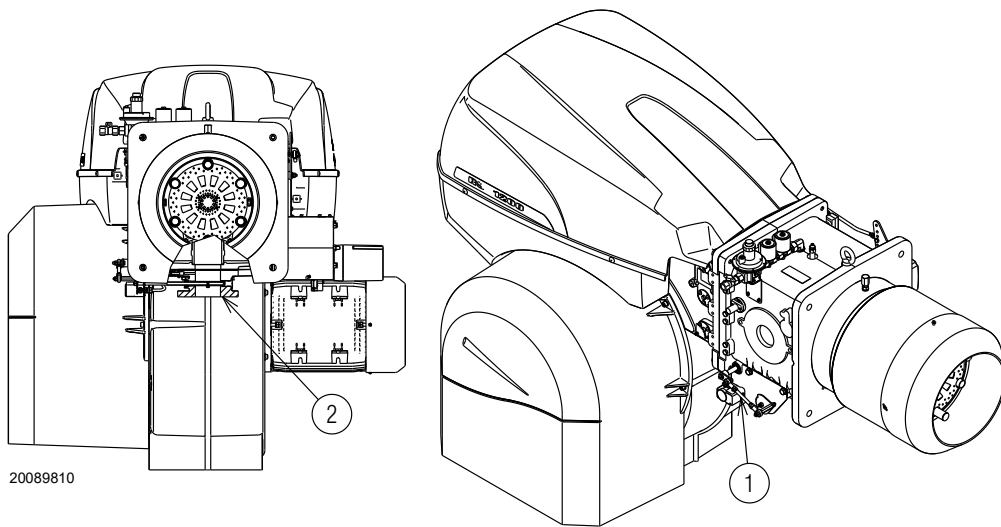

Fig. 18

### 4.11.5 Pilot - gas train connection

The burner is fitted with a dedicated gas train that is fixed to the pipe coupling.

- It should be connected to the main train downstream the filter or the pressure adjuster (depending on configuration).



Supply pressure  $68 \div 500$  mbar.

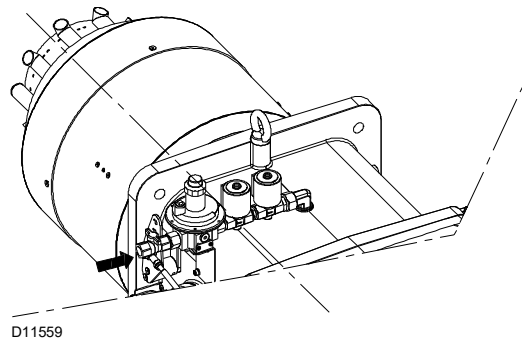

D11559

### 4.11.6 Ignition pilot burner

For proper operation, adjust gas pressure (measured at pressure test point 1)(Fig. 19) as follows:

Model	Gas	mbar	Sm <sup>3</sup> /h
RS 1000/M C01	G20	1.5	12.3
RS 1200/M C01	G20	40	14.3

Tab. K



Check pilot flame stability before starting up the main burner.

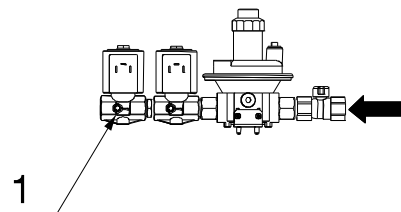

Fig. 19

In the case of ignition problems check:

- correct positioning of the ignition electrode;
- the gas pressure, according to indications.

**4.12 Electrical wiring**

**Notes on safety for the electrical wiring**



- The electrical wiring must be carried out with the electrical supply disconnected.
- Electrical wiring must be made in accordance with the regulations currently in force in the country of destination and by qualified personnel. Refer to the wiring diagrams.
- The manufacturer declines all responsibility for modifications or connections different from those shown in the wiring diagrams.
- Check that the electrical supply of the burner corresponds to that shown on the identification label and in this manual.
- The burner has been type-approved for intermittent use.  
This means they should compulsorily be stopped at least once every 24 hours to enable the flame control to perform checks of its own start-up efficiency. Normally, burner stopping is guaranteed by the boiler's thermostat/pressure switch.
- If this is not the case, a time switch should be fitted in series to TL to stop the burner at least once every 24 hours. Refer to the wiring diagrams.
- The electrical safety of the device is obtained only when it is correctly connected to an efficient earthing system, made according to current standards. It is necessary to check this fundamental safety requirement. In the event of doubt, have the electrical system checked by qualified personnel. Do not use the gas tubes as an earthing system for electrical devices.
- The electrical system must be suitable for the maximum power absorption of the device, as indicated on the label and in the manual, checking in particular that the section of the cables is suitable for that level of power absorption.
- For the main power supply of the device from the electricity mains:
  - do not use adapters, multiple sockets or extensions;
  - make provisions for an omnipolar switch with a gap between the contacts of at least 3 mm (over-voltage category III), as required by current safety regulations.
- Do not touch the device with wet or damp body parts and/or in bare feet.
- Do not pull the electric cables.

Before carrying out any maintenance, cleaning or checking operations:



Disconnect the electrical supply from the burner by means of the main system switch.



Close the fuel interception tap.



Avoid condensate, ice and water leaks from forming.

If the hood is still present, remove it and proceed with the electrical wiring according to the wiring diagrams.

Use flexible cables in compliance with the EN 60 335-1 standard.

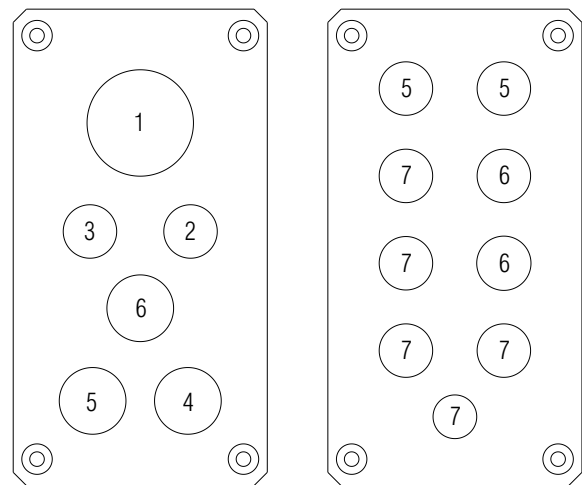

20062902

**Fig. 20**

**4.12.1 Supply cables and external connections passage**

All the cables to be connected to the burner should be passed through cable grommets, as shown in Fig. 20.



To guarantee the protection level of the burner, it is necessary to close any holes that are still free, using the plugs supplied.

Key (Fig. 20)

- 1 Electrical supply
- 2 minimum gas pressure switch
- 3 Pressure switch for VPS gas valve leak detection
- 4 Gas train
- 5 Consents/Safety
- 6 Available
- 7 Plug



After carrying out maintenance, cleaning or checking operations, reassemble the hood and all the safety and protection devices of the burner.

### 4.13 Calibration of the thermal relay

The thermal relay (Fig. 21) serves to avoid damage to the motor due to an excessive absorption increase or if a phase is missing. For calibration 2), refer to the table indicated in the electrical layout (electrical wiring in charge of the installer).

To reset, in case of an intervention of the thermal relay, press button "RESET" 1).

The button "STOP" 3) opens the NC contact (95-96) and stops the motor.

Insert a screwdriver in the window "TEST/TRIP" 4) and move it in the arrow direction (to the right) to carry out the thermal relay test.

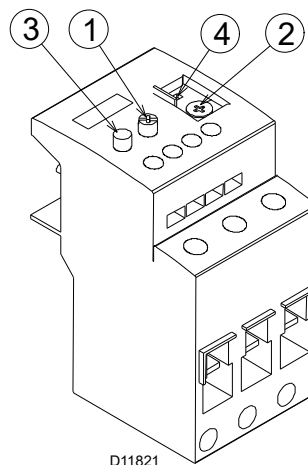

D11821

Fig. 21



WARNING

The automatic reset can be dangerous.

This operation is not foreseen in the burner operation.

### 4.14 Motor rotation

As the burner is not fitted with a phase sequence checking device, the motor rotation may be incorrect.



WARNING

As soon as the burner starts up, go in front of the fan motor cooling fan and check it is rotating anti-clockwise (Fig. 22).

If this is not the case:

- turn the burner switch to position "0" (OFF) and wait for the flame control to carry out the switch-off phase;
- disconnect the power supply to the main panel;
- invert the phases on the three-phase power supply.



DANGER

This operation must be carried out with the electrical supply disconnected.

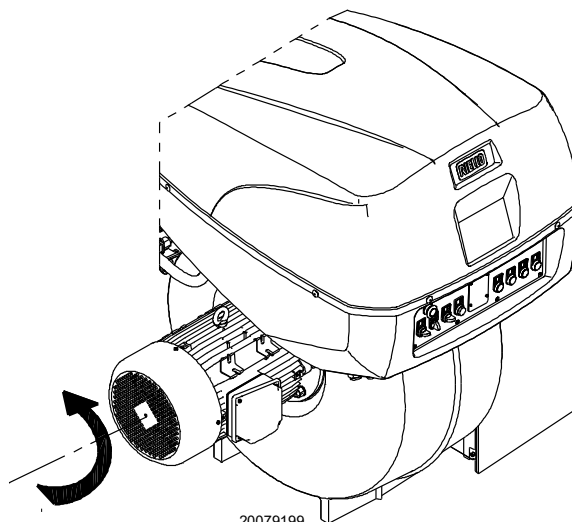

20079199

Fig. 22

**5 Start-up, calibration and operation of the burner**

**5.1 Notes on safety for the first start-up**



The first start-up of the burner must be carried out by qualified personnel, as indicated in this manual and in compliance with the standards and regulations of the laws in force.



Check the correct working of the adjustment, command and safety devices.



Refer to paragraph “Safety test - with gas ball valve closed” on page 30 before the first start-up.

**5.2 Adjustments prior to ignition**

The adjustments to be carried out are:

- Slowly open the manual valves situated upstream from the gas train.
- Adjust the minimum gas pressure switch (Fig. 30 on page 27) to the start of the scale.
- Adjust the maximum gas pressure switch (Fig. 29 on page 27) to the end of the scale.
- Adjust the air pressure switch (Fig. 28 on page 27) to the start of the scale.
- Purge the air from the gas line.  
We recommend using a plastic tube routed outside the building and to purge air until gas is smelt.
- Fit a U-type pressure gauge or a differential pressure gauge (Fig. 23), with socket (+) on the gas pressure of the pipe coupling and (-) in the combustion chamber. Used to approximately calculate the MAX burner output.
- Connect two lamps or testers to the two gas line solenoids to check the exact moment in which voltage is supplied. This operation is unnecessary if each of the two solenoid valves is equipped with a pilot light that signals voltage passing through.

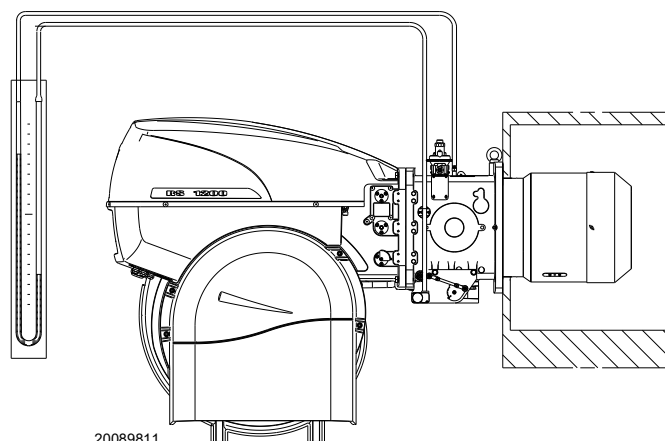

Fig. 23



Before starting up the burner, it is good practice to adjust the gas train so that ignition takes place in conditions of maximum safety, i.e. with gas delivery at the minimum.

**5.3 Burner start-up**

Close the remote controls and position the selector 1)(Fig. 24) to “AUTO”.

Make sure that the lights or testers connected to the solenoids, or the pilot lights on the solenoids themselves, indicate that no voltage is present.

If voltage is present, stop the burner immediately and check the electrical connections.

When the limit thermostat (TL) is closed, the “HEAT REQUEST” 3)(Fig. 24) signal must be on and the burner starts the starting cycle.

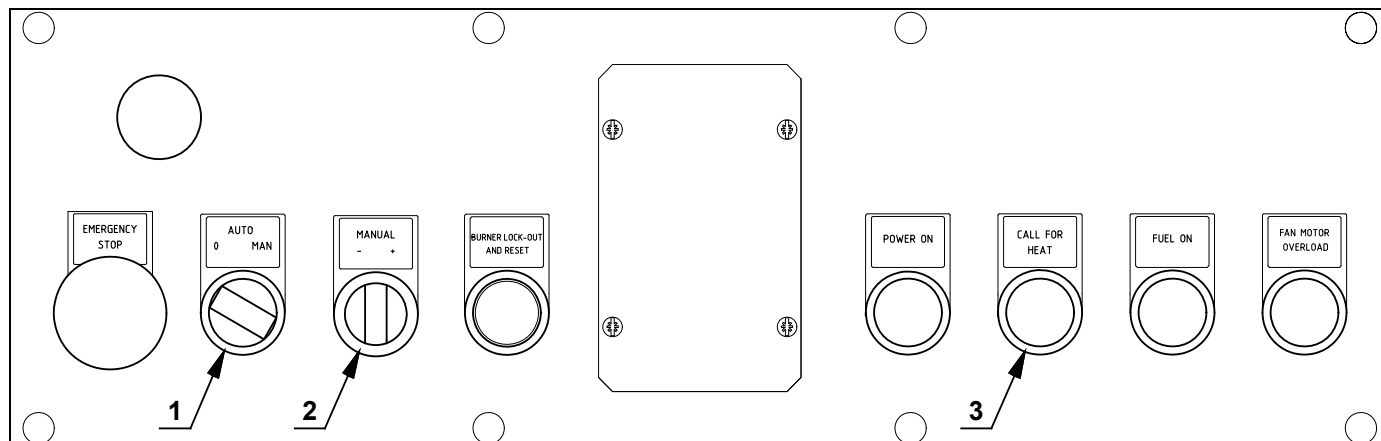

S8428

Fig. 24

**5.4 Burner ignition**

If the motor starts but the flame does not appear and the flame control goes into lockout, reset and wait for a new ignition attempt.

If ignition does not occur, it may be that the gas is not reaching the combustion head within the safety time of 3 seconds; therefore, the gas ignition delivery must be increased.

The arrival of gas at the pipe coupling is indicated by the U-type pressure gauge (Fig. 23).



In the event of a burner lockout, more than two consecutive burner reset operations could cause damage to the installation. On the third lockout, contact the Aftersales Service.



If further lockouts or burner faults occur, interventions must only be made by qualified, authorised personnel (as indicated in this manual, and in compliance with the laws and regulations currently in force).

Once the burner has ignited, proceed with the global adjustment of the burner.

**5.5 Servomotor adjustment**

The servomotor adjusts simultaneously, through driving gears, the output and pressure of the air and the delivery of the fuel in use. It performs a 130° rotation in 45s. After the adjustment made in the factory to its 6 cams to allow an initial ignition.

Check that they are as shown below.

In the event of a modification, follow what is described below for each cam:

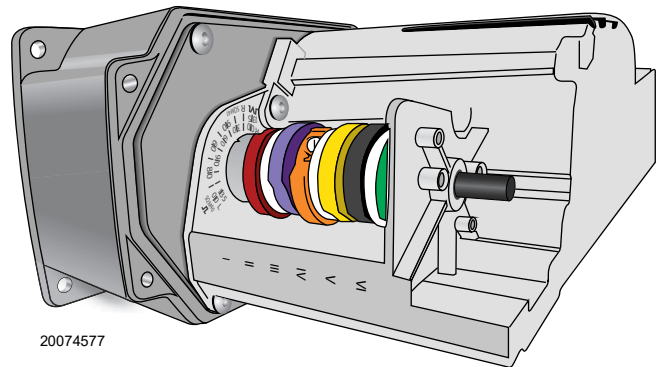

**Fig. 25**

**Cam I (RED):**                    **135°** (The same for all models). Limits rotation toward maximum position. Do not modify.



Do not make any adjustments.

**Cam II (BLUE):**                **0°** (The same for all models). Limits rotation toward minimum position. With the burner off, the air damper is completely closed: 0°.



It is recommended that no adjustments are made.

**Cam III (ORANGE):**        **20°** Adjusts the ignition position and the minimum output.

**Cam IV (YELLOW):**        **130°** Adjusts the ignition position and the maximum output.

**Cam V (BLACK):**             Not used.

**Cam VI (GREEN):**           Not used.

## 5.6 Burner adjustment and output modulation

### 5.6.1 Maximum output

The servomotor (Fig. 25) must be adjusted to the maximum opening so that the air dampers are completely open.

### 5.6.2 Minimum output

The MIN output must be set within the firing rate indicated on page 9.

Turn the selector 2)(Fig. 24 on page 23) "output reduction", and keep it turned to - until the servomotor has closed the air damper and the gas butterfly valve at 25° (adjustment made in the factory).

#### Air adjustment

The starting profile of cam 1)(Fig. 26) must be progressively adjusted by turning screws 2)(Fig. 26).



It is preferable not to turn the first screw since this is used to set the air damper to its fully closed position.

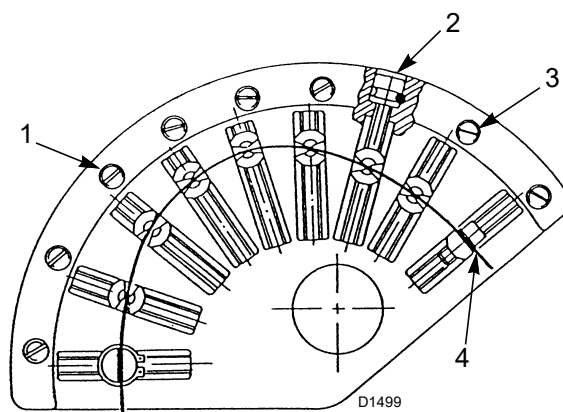

Fig. 26

Key (Fig. 26)

- 1 Cam
- 2 Adjustment screws
- 3 Locking screws
- 4 Adjustable profile

### 5.6.3 Intermediate outputs

After adjusting the maximum and minimum output of the burner, carry out air and gas adjustment on other intermediate positions of the servomotor.

The passage from one position to the next one is obtained by pressing the selector 2)(Fig. 24 on page 23) on the symbol + or -.

For better adjustment repeatability, take care to stop the rotation of the cam unit when the upper bearing that slides on the profile 4)(Fig. 26 on page 25) is aligned with one of the adjustment screws 2).

Screw or unscrew the preset screw 2) to increase or decrease the air output so as to adjust it to the corresponding gas output.



After output adjustment (maximum, minimum and intermediate), it is important to lock all the air adjustment screws 2) by the locking screws 3) so as to avoid possible movements from the position of air - gas calibration.

**5.7 Combustion air adjustment**

The air/fuel synchronisation is carried out by means of a servomotor 1)(Fig. 27) that, connected to a variable profile cam 2), operates on the delivery air dampers and, through proper leverage, on the combustion head and on the gas butterfly valve.



**WARNING!**  
**MOVING PARTS**



**WARNING!**  
**DANGER: CRUSHING OF LIMBS**

It is advisable, to reduce the loss and for a wide calibration field, to adjust the servomotor to the maximum of the output used, the nearest possible to the maximum opening (130°).

On the gas butterfly valve, fuel step according to the burner output required, with servomotor completely open, is carried out by the pressure stabilizer placed on the train.

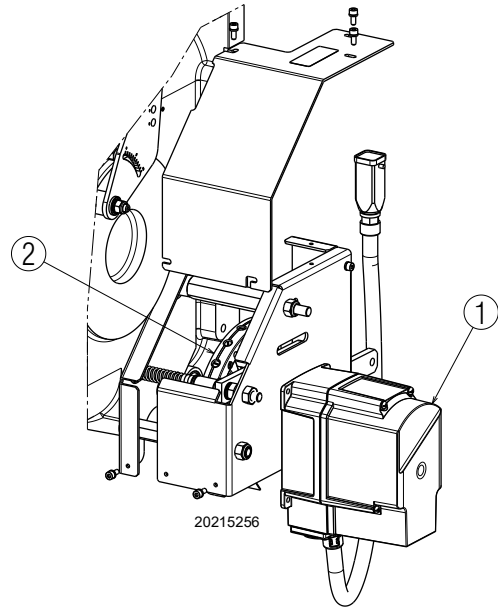

**Fig. 27**

The values in the Tab. L can be useful as reference for a good fuel calibration.

EN 676		Air excess		CO
		Max. output $\lambda \leq 1.2$	Max. output $\lambda \leq 1.3$	
GAS	Theoretical max. CO <sub>2</sub> 0 % O <sub>2</sub>	CO <sub>2</sub> % Calibration		mg/kWh
		$\lambda = 1.2$	$\lambda = 1.3$	
G 20	11.7	9.7	9	≤ 100
G 25	11.5	9.5	8.8	≤ 100
G 30	14.0	11.6	10.7	≤ 100
G 31	13.7	11.4	10.5	≤ 100

**Tab. L**

**5.8 Air / fuel adjustment**

During the calibration of the air / fuel ratio the following adjustments must be performed:

- **Air cam:**  
turn the adjustment screws 2)(Fig. 26 on page 25) after having loosened the screws 3).
- **Gas cam:**  
turn the adjustment screws 2)(Fig. 26 on page 25) after having loosened the screws 3).

**5.8.1 Burner calibration procedure**

After making a first ignition, verify the correct operation at the desired output. If this is not so, calibrate the gas cam.

With the optimal adjustment obtained, remember to lock the adjustment screws of the cam profiles by means of screws 3)(Fig. 26).



**WARNING**

During the calibration of the cam, do not exceed the travel limits of the servomotor 0 ÷ 130 to avoid sticking.

Check, again with a manual operation 0-130 of the cam, there are no mechanical stops before the activation of the micro-switches 1-2 of the servomotor.

**5.9 Pressure switch adjustment**

**5.9.1 Air pressure switch - check CO**

Adjust the air pressure switch after performing all other burner adjustments with the air pressure switch set to the start of the scale (Fig. 28).

With the burner operating at MIN output, increase adjustment pressure by slowly turning the relative knob clockwise until the burner locks out.

Then turn the knob anticlockwise by about 20% of the set point and repeat burner start-up to ensure it is correct.

If the burner locks out again, turn the knob anticlockwise a little bit more.



**WARNING**

In conformity with the standard, the air pressure switch must prevent the air pressure falling below 80% of the adjusted value and the CO in the flue gases exceeding 1% (10,000 ppm).

To check this, insert a combustion analyser into the chimney, slowly close the fan suction inlet (for example with cardboard) and check that the burner locks out, before the CO in the fumes exceeds 1%.

The air pressure switch is installed in "absolute" position, that is connected only to the pressure test point "+" 21)(Fig. 4).



**WARNING**

Connecting the air pressure switch in differential mode, the burner will no longer be certified according to the EN 676 standard.

**5.9.2 Maximum gas pressure switch**

Adjust the maximum gas pressure switch (Fig. 29) after making all other burner adjustments with the maximum gas pressure switch set to the end of the scale.

To calibrate the maximum gas pressure switch, open the tap and then connect a pressure gauge to its pressure test point.

The maximum gas pressure switch must be regulated to a value no higher than 30% of the measurement read on the gauge when the burner is working at maximum output.

After making the adjustment, remove the pressure gauge and close the tap.

**5.9.3 Minimum gas pressure switch**

The purpose of the minimum gas pressure switch is to prevent the burner from operating in an unsuitable way due to too low gas pressure.

Adjust the minimum gas pressure switch (Fig. 30) after having adjusted the burner, the gas valves and the gas train stabiliser.

With the burner operating at maximum output:

- install a pressure gauge downstream of the gas train stabiliser (for example at the gas pressure test point on the burner combustion head);
- choke slowly the manual gas cock until the pressure gauge detects a decrease in the pressure read of about 0.1 kPa (1 mbar). In this phase, verify the CO value which must always be less than 100 mg/kWh (93 ppm).
- Increase the adjustment of the gas pressure switch until it intervenes, causing the burner shutdown;
- remove the pressure gauge and close the cock of the gas pressure test point used for the measurement;
- open completely the manual gas cock.



**Fig. 28**

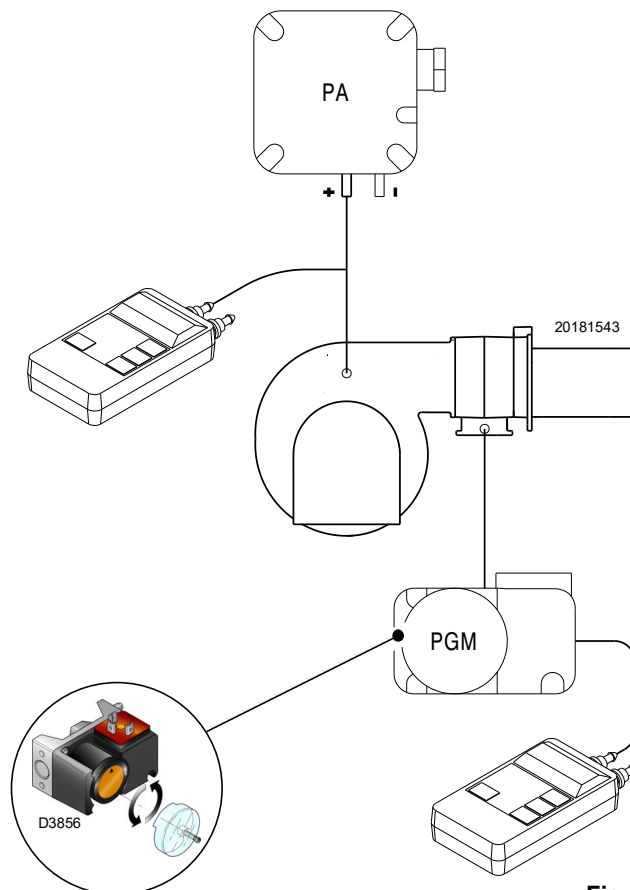

**Fig. 29**

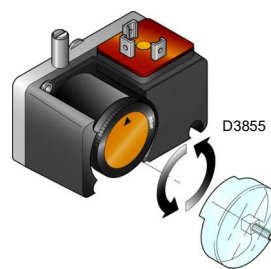

**Fig. 30**



**WARNING**

1 kPa = 10 mbar

**5.10 Operation sequence of the burner**

**5.10.1 Burner start-up**

- 0s TL thermostat/pressure switch closes.
- 6s Fan motor starts up. Servomotor starts: 130 rotation to the right, until contact is made on cam I.
- 48s The air damper is positioned to MAX output.
- 48s Pre-purging stage with MAX output air delivery. Duration 32 seconds.
- 80s The servomotor rotates to the left up to the angle set on the cam III.
- 112s The air damper and the gas butterfly valve adopt the MIN output position (with cam III).
- 113s Ignition electrode strikes a spark.
- 130s The safety valve VS opens, along with the adjustment valve VR (quick opening).  
The flame is ignited at a low output level, point A (Fig. 31). Output is then progressively increased, with the valve opening slowly up to MIN output, point B (Fig. 31).
- 122s The spark goes out.
- 143s The start-up cycle ends.

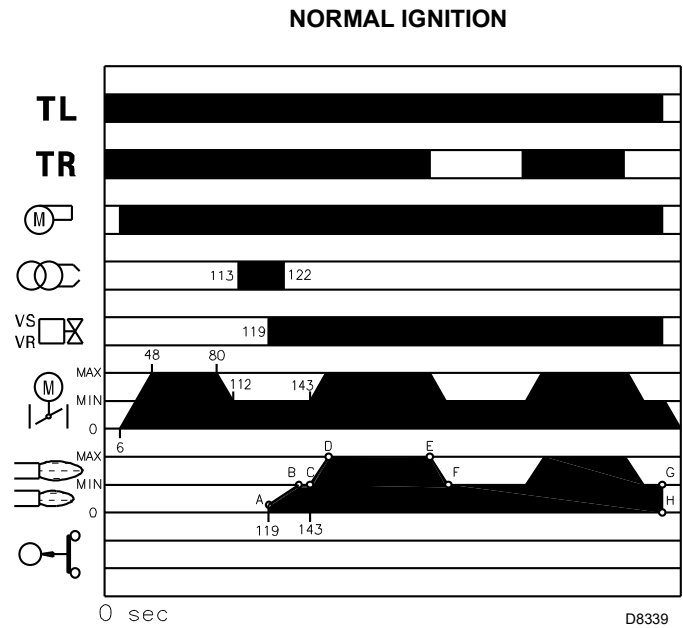

**Fig. 31**

**5.10.2 Operation**

**Burner without the output power regulator RWF50**

Once the start-up cycle is completed, the servomotor command moves on to the TR thermostat/pressure switch that controls the pressure or the temperature in the boiler, point C (Fig. 31). (The flame control continues to check the presence of the flame and the correct position of the air and gas maximum pressure switches).

- If the temperature or the pressure is low so the thermostat/pressure switch TR is closed, the burner progressively increases the output up to the MAX value (section C-D).
- If subsequently the temperature or pressure increases until TR opens, the burner progressively decreases its output to the MIN. value (section E-F). The sequence repeats endlessly.
- The burner locks out when the heat request is less than the heat supplied by the burner at MIN. output, (section G-H). The TL thermostat/pressure switch opens, and the servomotor returns to angle 0 limited by the contact of the cam 2). The air damper closes completely to reduce heat losses to a minimum.

For every change of output, the servomotor will automatically change the gas flow rate (butterfly valve), the airflow (fan damper) and the air pressure (2 shutters in the combustion head).

**Burner with the output power regulator RWF50**

See manual enclosed with the adjuster.

**NO IGNITION**

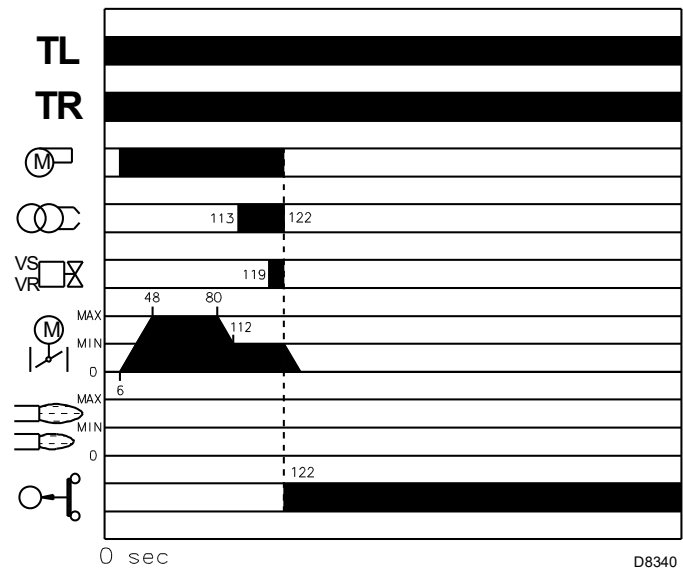

**Fig. 32**





**5.10.3 Burner flame goes out during operation**

If the flame should accidentally go out during operation, the burner will lock out within 1s.

**5.10.4 Ignition failure**

If the burner does not fire (Fig. 32), it goes into lockout within 3 sec. after the gas valve opens, 122 seconds after the control device TL.

**5.11 Final checks (with burner operating)**

<ul style="list-style-type: none"> <li>➤ Open the thermostat/pressure switch TL</li> <li>➤ Open the thermostat/pressure switch TS</li> </ul>		The burner must stop
<ul style="list-style-type: none"> <li>➤ Turn the gas maximum pressure switch knob to the minimum end of scale position</li> <li>➤ Turn the air pressure switch to the maximum end of scale position</li> </ul>		The burner must stop in lockout
<ul style="list-style-type: none"> <li>➤ Turn off the burner and cut off the power</li> <li>➤ Disconnect the minimum gas pressure switch connector</li> </ul>		The burner must not start
<ul style="list-style-type: none"> <li>➤ Disconnect electrically the sensor for the flame detection</li> </ul>		The burner must stop in lockout due to ignition failure

**Tab. M**



**WARNING**

Make sure that the mechanical locking systems on the various adjustment devices are fully tightened.

**6 Maintenance**

**6.1 Notes on safety for the maintenance**

The periodic maintenance is essential for the good operation, safety, yield and duration of the burner.

It allows you to reduce consumption and polluting emissions and to keep the product in a reliable state over time.



The maintenance interventions and the calibration of the burner must only be carried out by qualified, authorised personnel, in accordance with the contents of this manual and in compliance with the standards and regulations of current laws.

Before carrying out any maintenance, cleaning or checking operations:



Disconnect the electrical supply from the burner by means of the main system switch.



Close the fuel interception tap.



Wait for the components in contact with heat sources to cool down completely.

**6.2 Maintenance programme**

**6.2.1 Maintenance frequency**



The gas combustion system should be checked at least once a year by a representative of the manufacturer or another specialised technician.

**6.2.2 Safety test - with gas ball valve closed**

It is fundamental to ensure the correct execution of the electrical connections between the gas solenoid valves and the burner to perform safely the commissioning.

For this purpose, after checking that the connections have been carried out in accordance with the burner's electrical diagrams, an ignition cycle with closed gas ball valve -dry test- must be performed.

- 1 The manual ball gas valve must be closed
- 2 The electrical contacts of the burner limit switch need to be closed
- 3 Ensures closed the contact of the low gas pressure switch
- 4 Make a trial for burner ignition

The start-up cycle must be as follows:

- Starting the fan for pre-ventilation
- Performing the gas valve seal control, if provided
- Completion of pre-ventilation
- Arrival of the ignition point
- Power supply of the ignition transformer
- Electrical Supply of solenoid gas valves

Since the manual gas ball valve is closed, the burner will not light up and its flame control will go to a safety lockout condition.

The actual electrical supply of the solenoid gas valves can be verified by inserting a tester. Some valves are equipped with light signals (or close/open position indicator) that turn on at the same time as their power supply.



**IF THE ELECTRICAL SUPPLY OF THE GAS VALVES OCCURS AT UNEXPECTED TIMES, DO NOT OPEN MANUAL GAS BALL VALVE, SWITCH OFF POWER LINE; CHECK THE WIRES; CORRECT THE ERRORS AND REPEAT THE COMPLETE TEST.**

**6.2.3 Checking and cleaning**



The operator must use the required equipment during maintenance.

**Combustion**

Carry out an analysis of the combustion discharge gases. Significant differences with respect to the previous check indicate the points where more care should be exercised during maintenance.

**Combustion head**

Open the burner and make sure that all components of the combustion head are in good condition, not deformed by the high temperatures, free of impurities from the surroundings and correctly positioned.

**Burner**

Check that there are not excess wear or loose screws, especially on the cam.

Clean the outside of the burner.

Clean and grease the adjustable profile of the cams.

**Fan**

Check to make sure that no dust has accumulated inside the fan or on its blades, as this condition will cause a reduction in the air flow rate and provoke polluting combustion.

**Current to the flame sensor (Fig. 33)**

Clean the glass cover from any dust that may have accumulated. The sensor is held in position by a pressure fit and can therefore be removed by pulling it outward forcefully.

Min value for a good work: 70  $\mu$ A.

If the value is lower, it can depend on:

- exhausted sensor;
- low current (lower than 187 V);
- bad regulation of the burner.

In order to measure the current, use a microammeter of 100  $\mu$ A c.c., connected to the sensor, as in the scheme, with a capacitor of 100  $\mu$ F - 1V c.c. at the same level of the instrument.

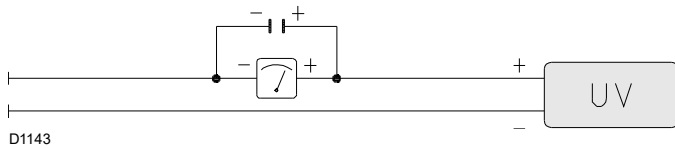

**Fig. 33**

**Boiler**

Clean the boiler as indicated in its accompanying instructions in order to maintain all the original combustion characteristics intact, especially the flue gas temperature and combustion chamber pressure.

**Gas leaks**

Make sure that there are no gas leaks on the pipes between the gas meter and the burner.

**Gas filter**

Replace the gas filter when it is dirty.

**Combustion**

If the combustion values found at the start of the intervention do not satisfy current standards or anyway indicate a poor state of combustion (consult the table below), contact the Technical Assistance Service for the necessary adjustments.

EN 676		Air excess		CO
		Max. output $\lambda \leq 1.2$	Max. output $\lambda \leq 1.3$	
GAS	Theoretical max. CO <sub>2</sub> 0 % O <sub>2</sub>	CO <sub>2</sub> % Calibration		mg/kWh
		$\lambda = 1.2$	$\lambda = 1.3$	
G 20	11.7	9.7	9	$\leq 100$
G 25	11.5	9.5	8.8	$\leq 100$
G 30	14.0	11.6	10.7	$\leq 100$
G 31	13.7	11.4	10.5	$\leq 100$

**Tab. N**

**6.2.4 Safety components**

The safety components must be replaced at the end of their life cycle indicated in Tab. O.

The specified life cycles do not refer to the warranty terms indicated in the delivery or payment conditions.

Safety component	Life cycle
Flame control	10 years or 250,000 operation cycles
Flame sensor	10 years or 250,000 operation cycles
Gas valves (solenoid)	10 years or 250,000 operation cycles
Pressure switches	10 years or 250,000 operation cycles
Pressure adjuster	15 years
Servomotor (electronic cam) (if present)	10 years or 250,000 operation cycles
Oil valve (solenoid) (if present)	10 years or 250,000 operation cycles
Oil regulator (if present)	10 years or 250,000 operation cycles
Oil pipes / couplings (metallic) (if present)	10 years
Fan impeller	10 years or 500,000 start-ups

**Tab. O**

### 6.3 Opening the burner



Disconnect the electrical supply from the burner by means of the main system switch.



Close the fuel interception tap.



Wait for the components in contact with heat sources to cool down completely.

- Remove the tie-rods 1) and 4)(Fig. 34) of the head movement and damper opening lever, loosening the nuts 2);
- disconnect the socket 3) of the servomotor;
- remove the screws 5).

At this point, it is possible to open the burner on the hinge.

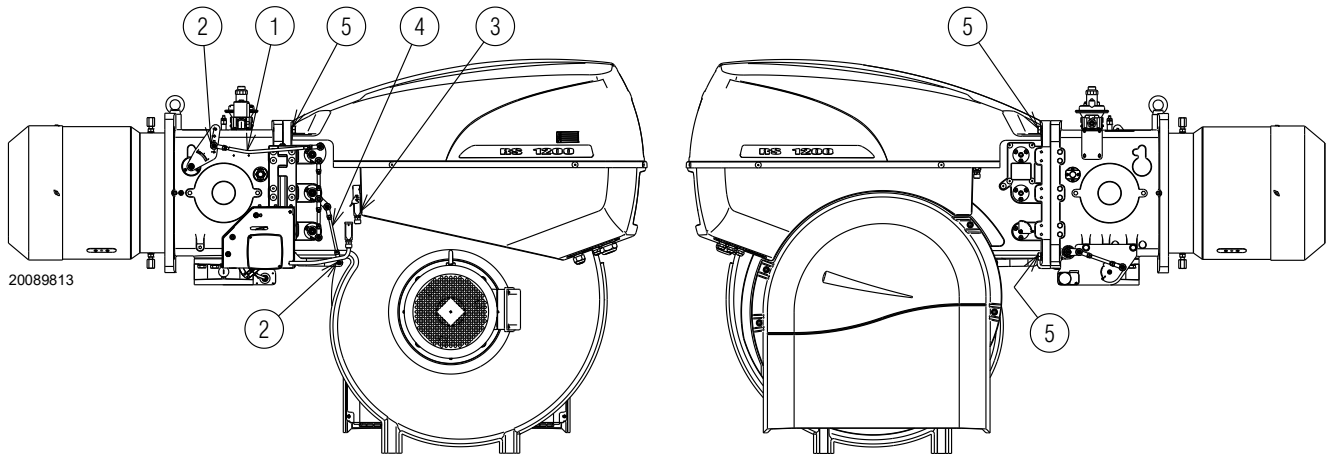

Fig. 34

### 6.4 Closing the burner

Refit following the steps described but in reverse order; refit all burner components as they were originally assembled.



Carry out all maintenance work and mount the casing again.

**7** Faults - Possible causes - Solutions

The LFL... flame control is equipped with a lockout indicator (Fig. 35) that turns during the start-up programme, and is visible from the small lockout window.

When the burner does not start or stops, due to a failure, the symbol that appears on the indicator indicates the type of interruption. The positions of the lockout indicator are shown in Fig. 36.



**Lockout indicator**

- a-b Start-up sequence
- b(b') Idle stages (without contact confirmation)
- b(b')-a Post-purging programme

Fig. 35

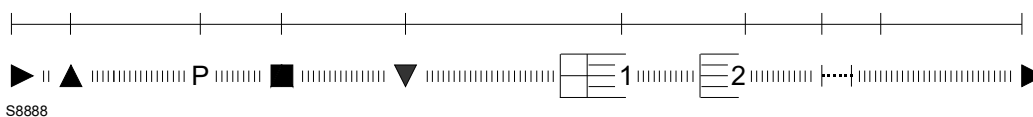

Fig. 36

**Fuse replacement**

The fuse 2)(Fig. 37) is in the rear part of the flame control. A spare fuse 1) is also available: it can be extracted after breaking the panel tab A) that houses it. In the event that fuse 2) has been tripped, replace it as shown in Fig. 37.

Find a list of faults, causes and possible solutions for a set of failures that may occur and result in irregular burner operation or no functioning at all.

If a burner malfunction is detected, first of all:

- check that the electrical wiring is adequately connected;
- check whether fuel is delivered;
- check that every adjustment parameter is adequately set.



**WARNING**

In the event the burner stops, in order to prevent any damage to the installation, do not unblock the burner more than twice in a row. If the burner locks out for a third time, contact the customer service.



**DANGER**

In the event there are further lockouts or faults with the burner, the maintenance interventions must only be carried out by qualified, authorised personnel, in accordance with the contents of this manual and in compliance with the standards and regulations of current laws.

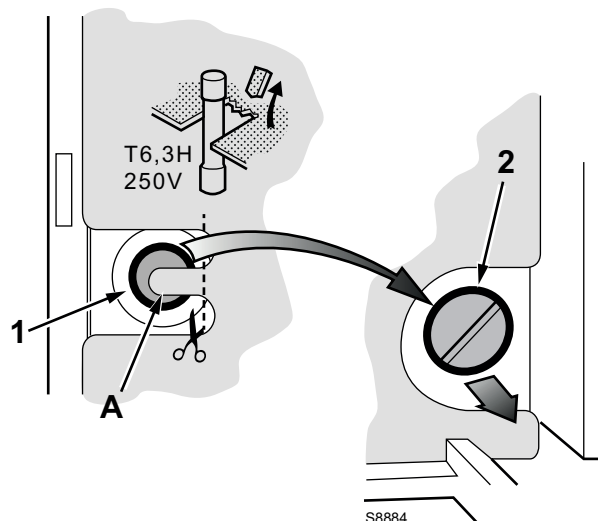

Fig. 37

### 7.1 Gas operation

Symbol	Problem	Probable cause	Suggested remedy
◀	The burner does not start	No electrical power supply	Close all switches and check connections
		A limit or safety thermostat/pressure switch open	Adjust or replace
		Flame control lockout	Release the flame control
		Flame control fuse interrupted	Replace it (2)
		Incorrect electrical wiring	Check
		Defective flame control	Replace
		No gas supply	Open the manual valves between meter and train
		Mains gas pressure insufficient	Contact your GAS COMPANY
		Minimum gas pressure switch fails to close	Adjust or replace
		Air pressure switch in operating position	Adjust or replace
	The servomotor contact does not intervene (closure cam 0°)	Adjust the closure cam 0° or replace the servomotor	
	The burner does not come on and the lockout appears	Flame simulation	Replace the flame control
		Faulty motor remote control switch	Replace
		Defective electrical motor	Replace
Motor lockout		Release the thermal relay	
▲	The burner starts but stops at maximum air damper setting	The servomotor contact does not intervene (maximum cam opening)	Cam adjustment (maximum opening) or replace the servomotor
P	The burner starts and then goes into lockout	Air pressure switch does not switch owing to lack of air pressure:	
		Air pressure switch poorly adjusted	Adjust or replace
		Pressure switch pressure point pipe clogged	Clean
		Poorly adjusted head	Adjust
		Dirty fan	Clean
	High depression in the furnace	Contact our Technical Department	
■	The burner turns on and then remains in lockout mode	Failure to the flame detection circuit	Replace the flame control
▼	The burner remains in pre-purging phase	The servomotor contact does not intervene (minimum cam)	Cam adjustment (minimum) or replace the servomotor

Symbol	Problem	Probable cause	Suggested remedy
1	Once the pre-purging and the safety time has elapsed the burner goes into lockout without the flame appearing	The GAS solenoid valve lets too little gas through	Increase
		The GAS solenoid valve does not open	Replace the coil or the rectifier panel
		Gas pressure too low	Increase pressure at governor
		Ignition electrode incorrectly adjusted	Adjust it
		Electrode grounded due to broken insulation	Replace
		High voltage cable defective or grounded	Replace
		High voltage cable deformed by high temperature	Replace and protect
		Faulty ignition transformer	Replace
		Incorrect valve or ignition transformer connections	Redo them
		Defective flame control	Replace
		A closed valve upstream the gas train	Open
		Air in pipework	Bleed air
		Lockout with flame appearing	The GAS solenoid valve lets too little gas through
	Dirty flame sensor		Check, replace flame sensor
Faulty connection	Check, replace flame sensor		
Insufficient detection current (min.70 µA)	Measure current, replace flame sensor		
Flame sensor exhausted, faulty	Replace		
Maximum gas pressure switch intervention	Adjust or replace		
Defective flame control	Replace		
	The burner continues to repeat the start-up cycle without lockout	The gas pressure in the gas mains lies very close to the value to which the gas pressure switch has been set. The sudden drop in pressure after valve opening causes temporary opening of the pressure switch itself, the valve immediately closes and the burner stops. Pressure increases again, the pressure switch closes again and the ignition cycle is repeated. And so on.	Reduce the intervention pressure of the minimum gas pressure switch. Replace the gas filter cartridge
	Lockout without symbol indication	Flame simulation	Replace the flame control
	Burner goes into lockout during operation	Faulty flame sensor	Replace worn parts
		Air pressure switch faulty	Replace
◀	Lockout when the burner stops	Permanent flame in the combustion head or flame simulation	Eliminate permanency of flame or replace the flame control
	Ignition with pulsations	Poorly adjusted head	Adjust
		Ignition electrode incorrectly adjusted	Adjust it
		Incorrectly adjusted fan air damper: too much air	Adjust
		Output during ignition phase is too high	Reduce

Tab. P

## A Appendix - Accessories

### Output power regulator kit for modulating operation

With the modulating operation, the burner continually adapts the power to the request for heat, ensuring great stability for the parameter controlled: temperature or pressure.

Two components should be ordered:

- the output power regulator to be installed on the burner;
- the probe to be installed on the heat generator.

Parameter to be checked		Probe		Output regulator	
	Adjustment field	Type	Code	Type	Code
Temperature	- 100...+ 500°C	PT 100	3010110	RWF50	20101190
Pressure	0...2.5 bar	Output probe 4...20 mA	3010213	RWF55	20101191
	0...16 bar		3010214		

### Output power regulator with signal 4-20 mA, 0-10V

Two components should be ordered:

- the analogue signal converter;
- the Potentiometer

Burner	Potentiometer		Analogue Signal Converter	
	Type	Code	Type	Code
RS 1000/M C01	ASZ...	20096322	E5202	3010390
RS 1200/M C01				

### Continuous purging kit

Burner	Code
RS 1000/M C01	3010094
RS 1200/M C01	

### Soundproofing box kit

Burner	Code
RS 1000/M C01	3010401
RS 1200/M C01	

### Gas trains in compliance with EN 676

Please refer to manual.

**B Appendix - Electrical panel layout**

<b>1</b>	<b>Index of layouts</b>
<b>2</b>	Indication of references
<b>3</b>	Single-wire output layout
<b>4</b>	Functional layout star/triangle starter
<b>5</b>	Functional layout
<b>6</b>	Functional layout
<b>7</b>	Functional layout
<b>8</b>	Functional layout
<b>9</b>	Functional diagram
<b>10</b>	Electrical wiring that the installer is responsible for
<b>11</b>	Electrical wiring that the installer is responsible for
<b>12</b>	Electrical wiring kit RWF50 internal
<b>13</b>	Electrical wiring kit RWF50 external

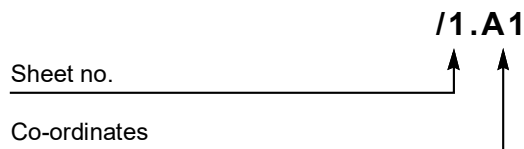
**2 Indication of references**

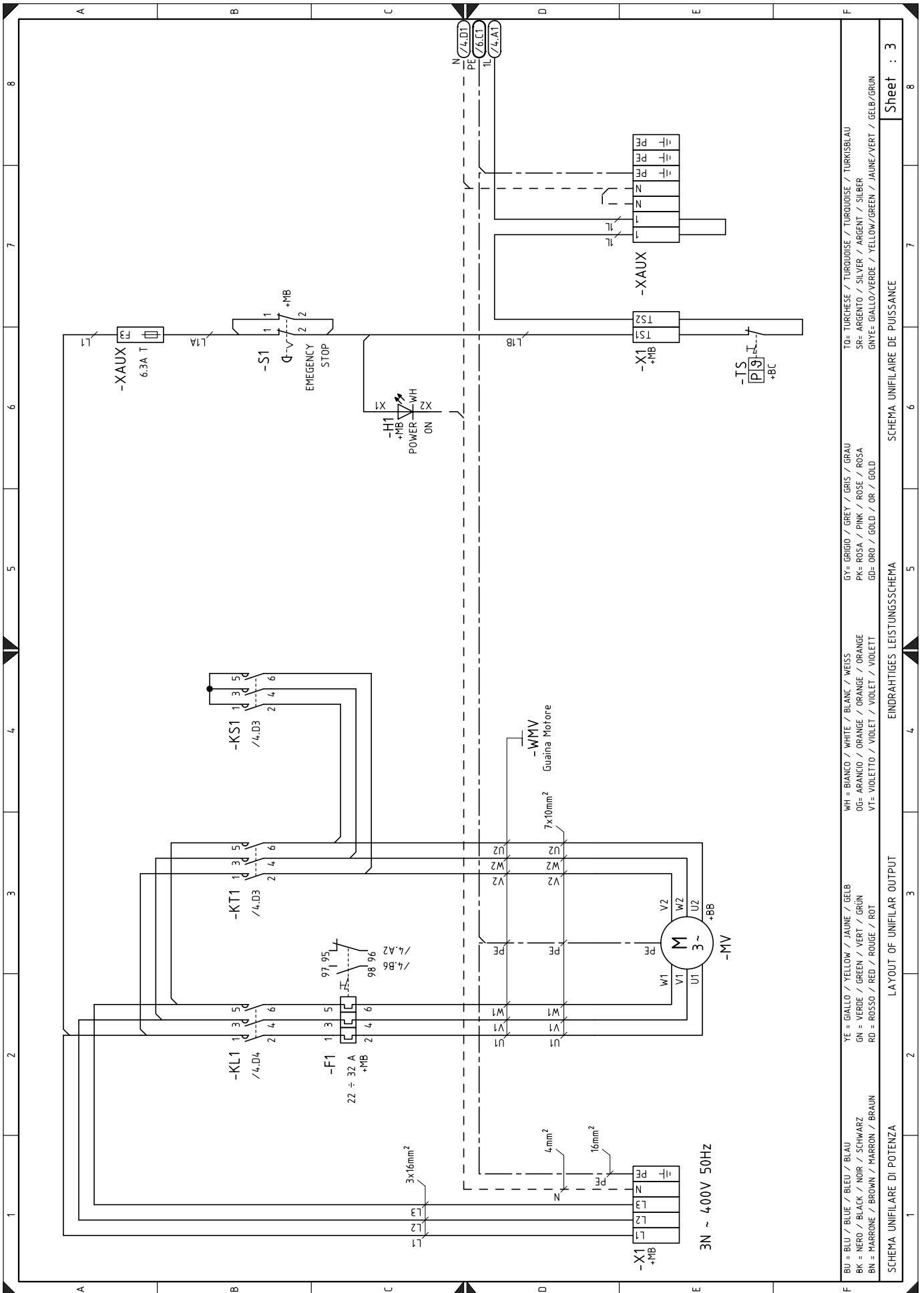

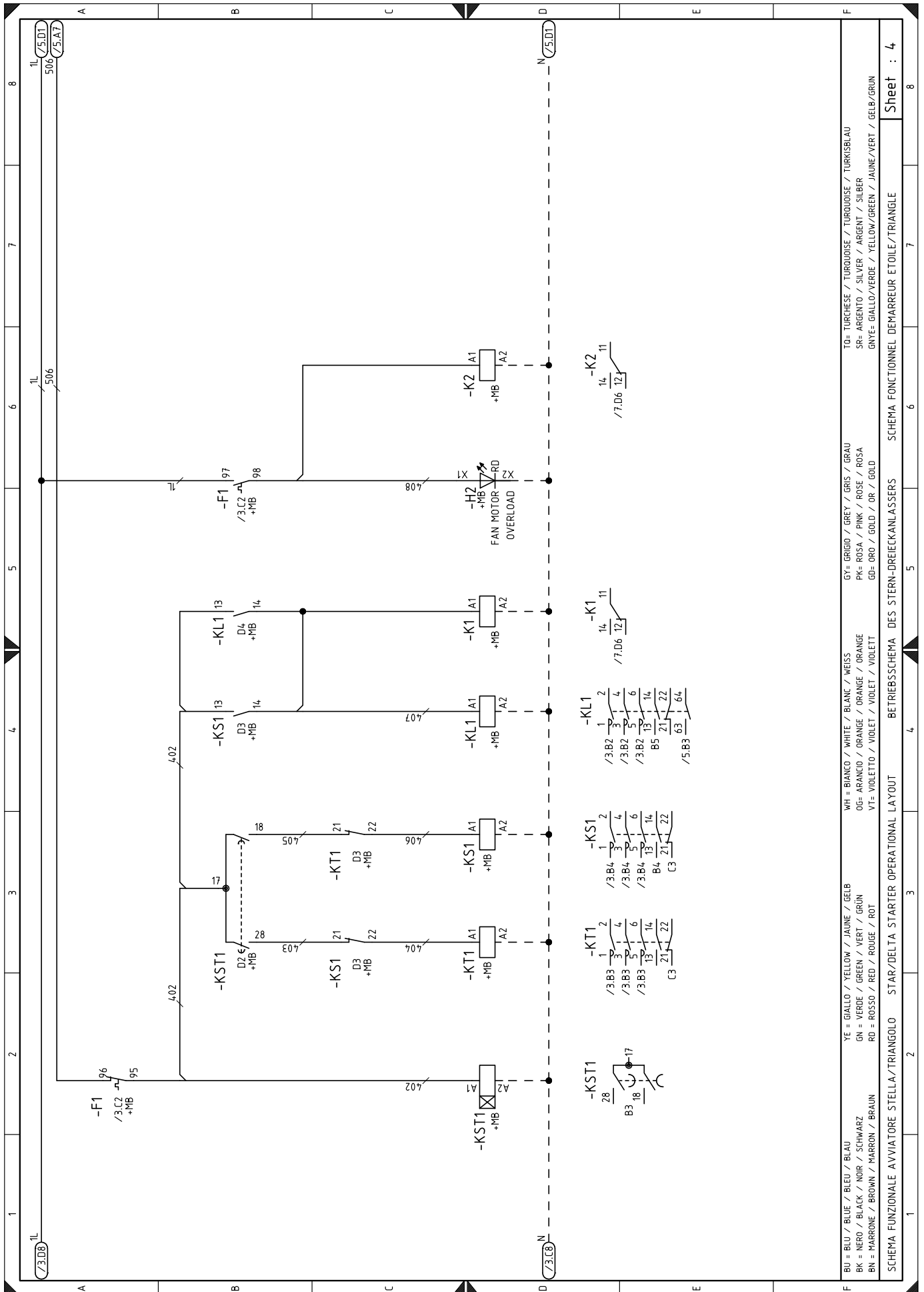

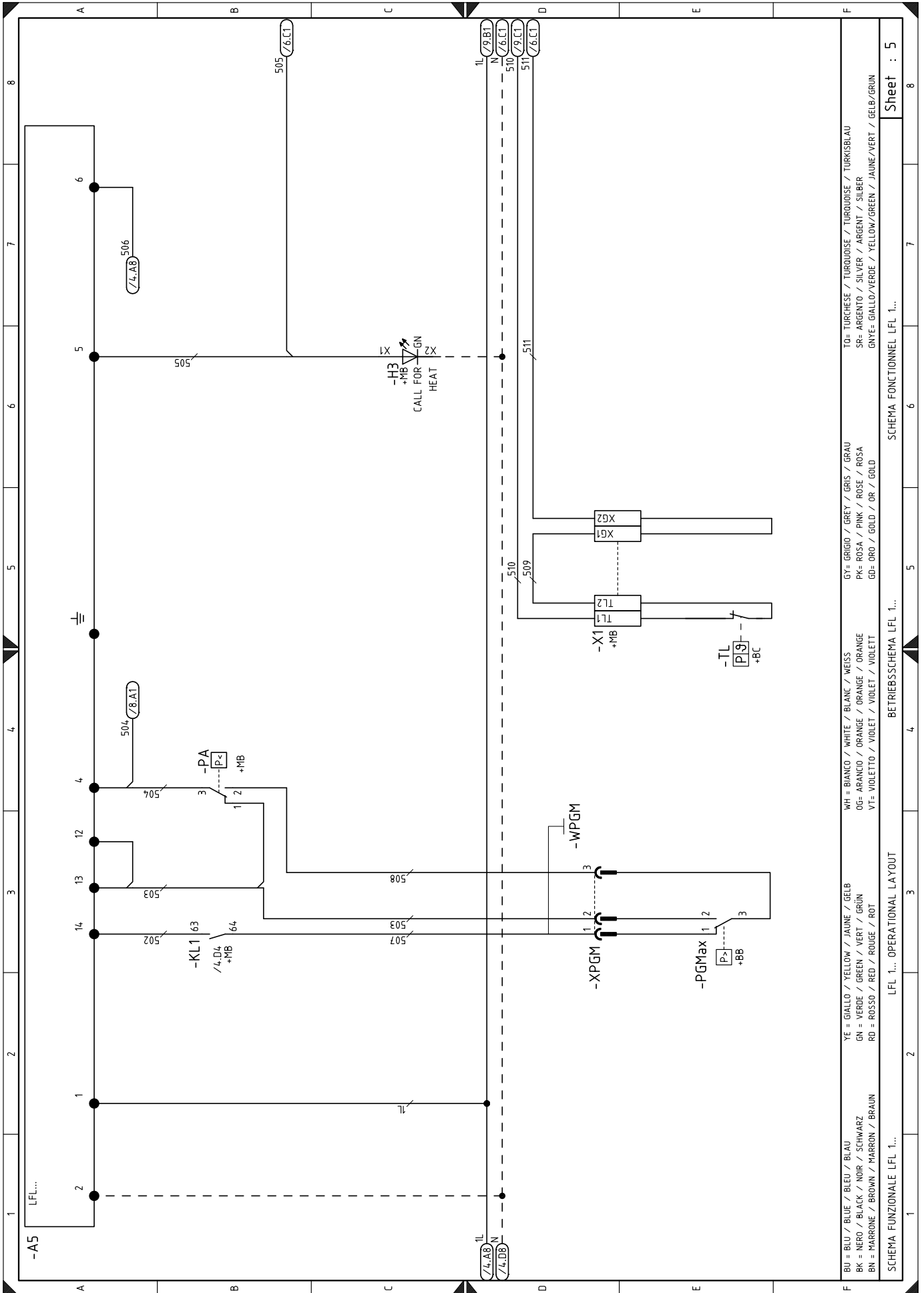

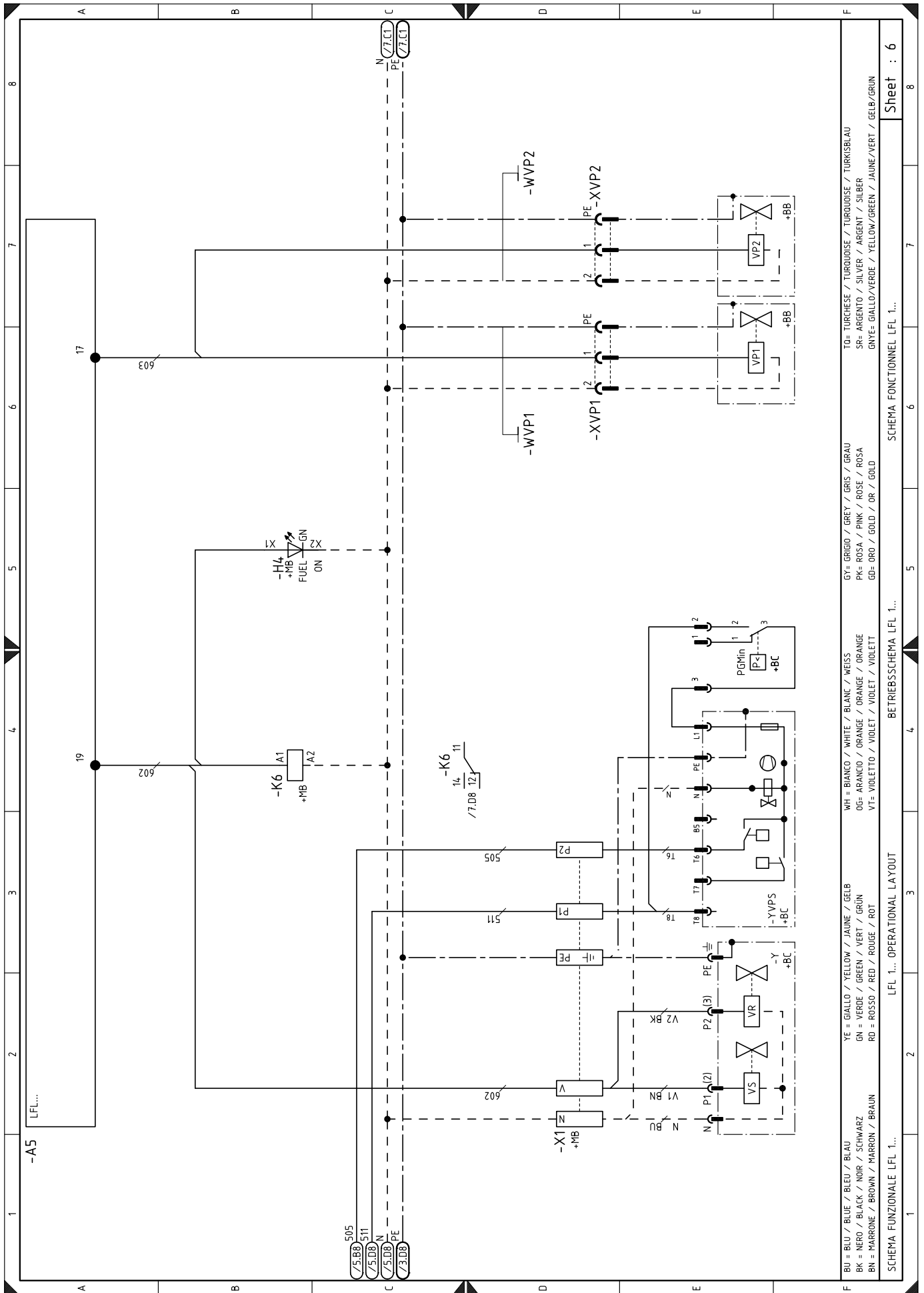

TO= TURCHESE / TURQUOISE / TURKUISE / TURKISBLAU  
 SR= ARGENTO / SILVER / ARGENT / SILBER  
 GNYE= GIALLO/VERDE / YELLOW/GREEN / JAUNE/VERT / GELB/GRUN

GY= GRIGIO / GREY / GRIS / GRAU  
 PK= ROSA / PINK / ROSE / ROSA  
 GD= ORO / GOLD / OR / GOLD

WH= BIANCO / WHITE / BLANC / WEISS  
 O= ARANCIO / ORANGE / ORANGE / ORANGE  
 V= VIOLETT / VIOLET / VIOLET / VIOLETT

YE= GIALLO / YELLOW / JAUNE / GELB  
 GN= VERDE / GREEN / VERT / GRUN  
 RD= ROSSO / RED / ROUGE / ROT

BU= BLU / BLUE / BLEU / BLAU  
 BK= NERO / BLACK / NOIR / SCHWARZ  
 BN= MARRONE / BROWN / MARRON / BRAUN

SCHEMA FUNZIONALE LFL 1...  
 SCHEMA FONCTIONNEL LFL 1...  
 BETRIEBSSCHEMA LFL 1...  
 LFL 1... OPERATIONAL LAYOUT



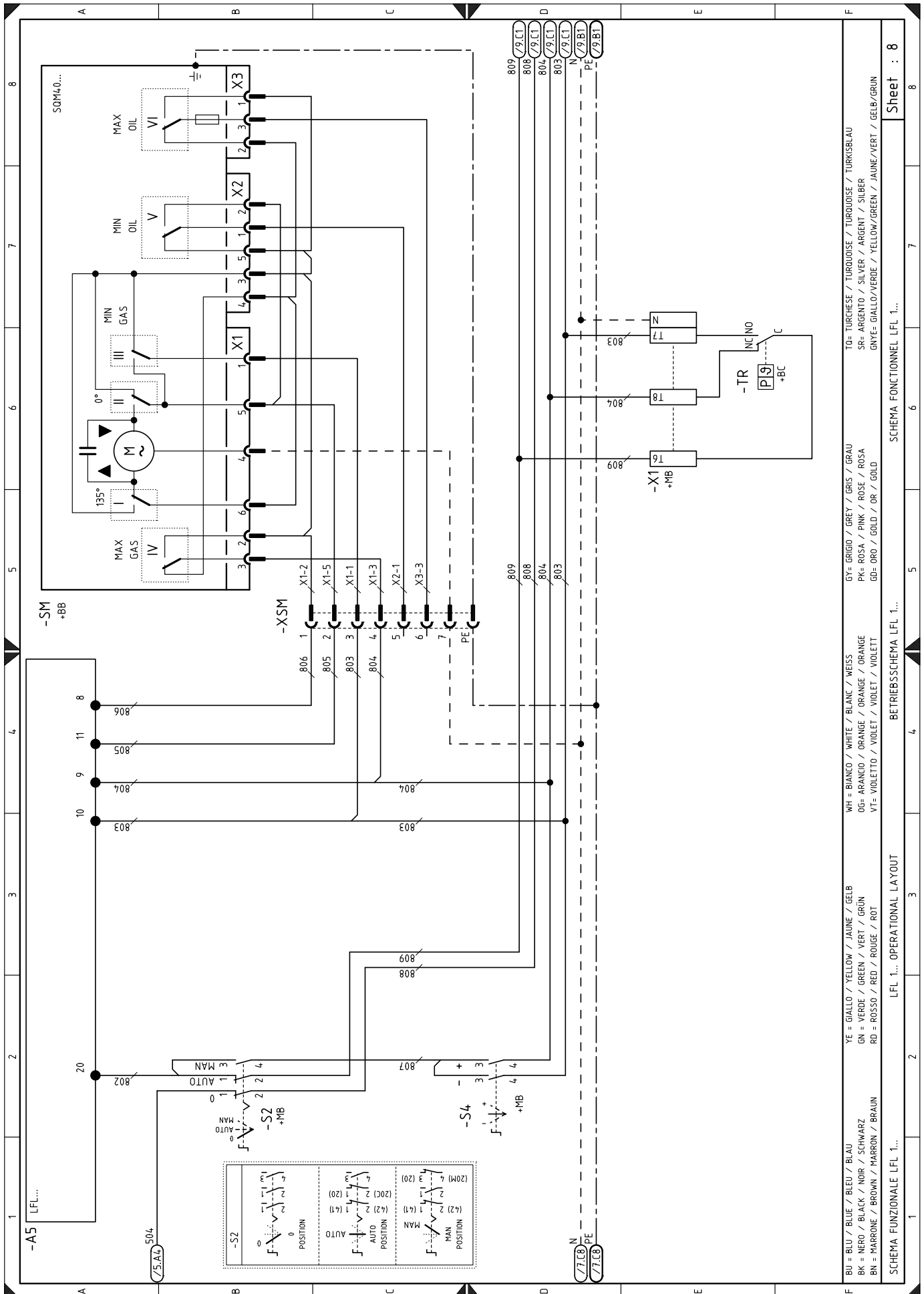

Sheet : 8

SCHEMA FONCTIONNEL LFL 1...

BETRIEBSSCHEMA LFL 1...

LFL 1... OPERATIONAL LAYOUT

SCHEMA FUNZIONALE LFL 1...



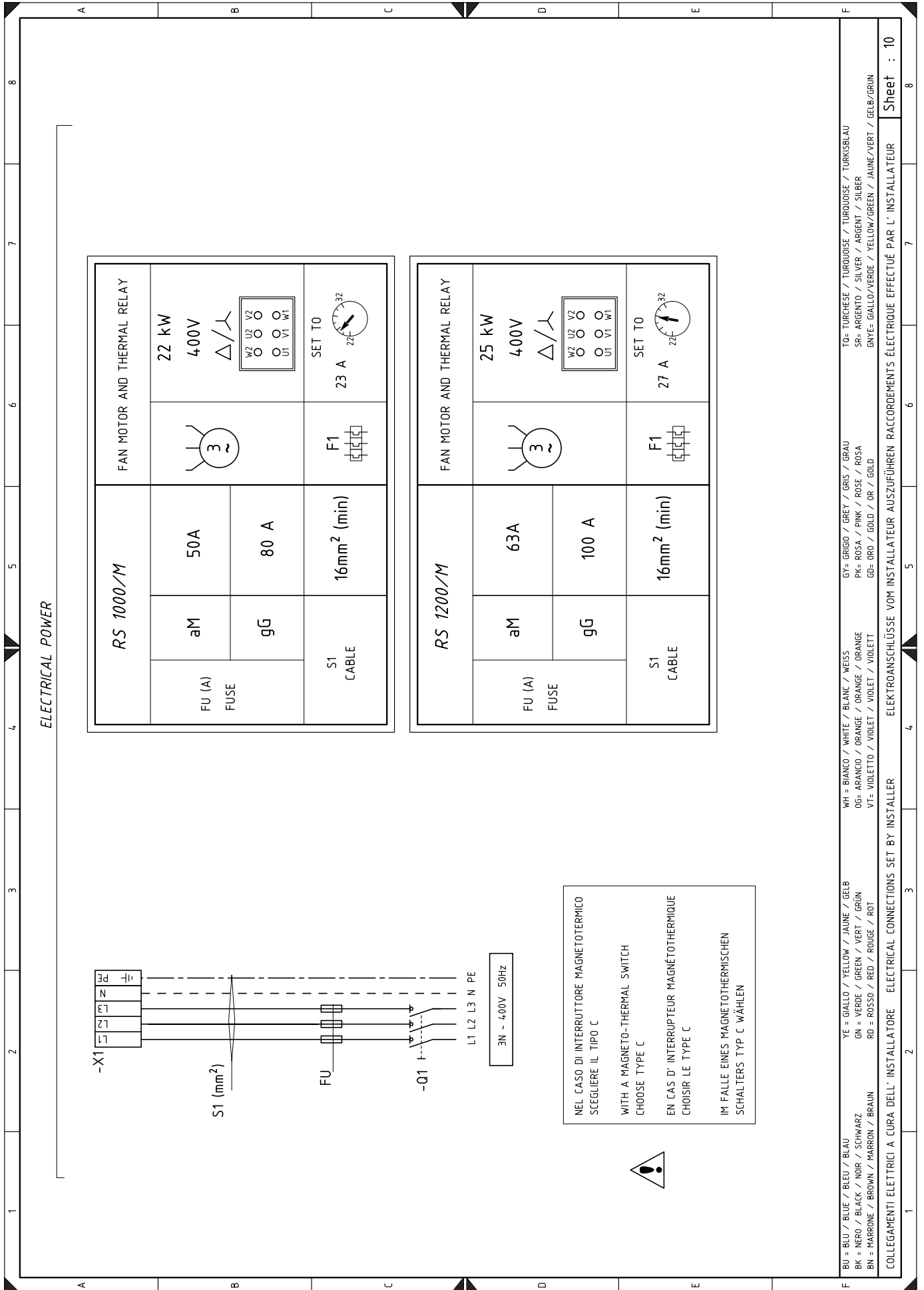

BU = BLU / BLUE / BLEU / BLAU  
 BK = NERO / BLACK / NOIR / SCHWARZ  
 BN = MARRONE / BROWN / MARRON / BRAUN  
 YE = GIALLO / YELLOW / JAUNE / GELB  
 GN = VERDE / GREEN / VERT / GRÜN  
 RD = ROSSO / RED / ROUGE / ROT  
 WH = BIANCO / WHITE / BLANC / WEISS  
 OG= ARANCIO / ORANGE / ORANGE / ORANGE  
 VT= VIOLETT / VIOLET / VIOLET / VIOLETT  
 GY= GRIGIO / GREY / GRIS / GRAU  
 PK= ROSA / PINK / ROSE / ROSA  
 GD= ORO / GOLD / OR / GOLD  
 TO= TURCHESE / TURQUOISE / TURQUOISE / TURKISBLAU  
 SR= ARGENTO / SILVER / ARGENT / SILBER  
 GNY= GIALLO/VERDE / YELLOW/GREEN / JAUNE/VERT / GELB/GRÜN

COLLEGAMENTI ELETTRICI A CURA DELL'INSTALLATORE ELECTRICAL CONNECTIONS SET BY INSTALLER  
 ELEKTROANSCHLÜSSE VOM INSTALLATEUR AUSZUFÜHREN RACCORDEMENTS ÉLECTRIQUE EFFECTUÉ PAR L'INSTALLATEUR  
 Sheet : 10

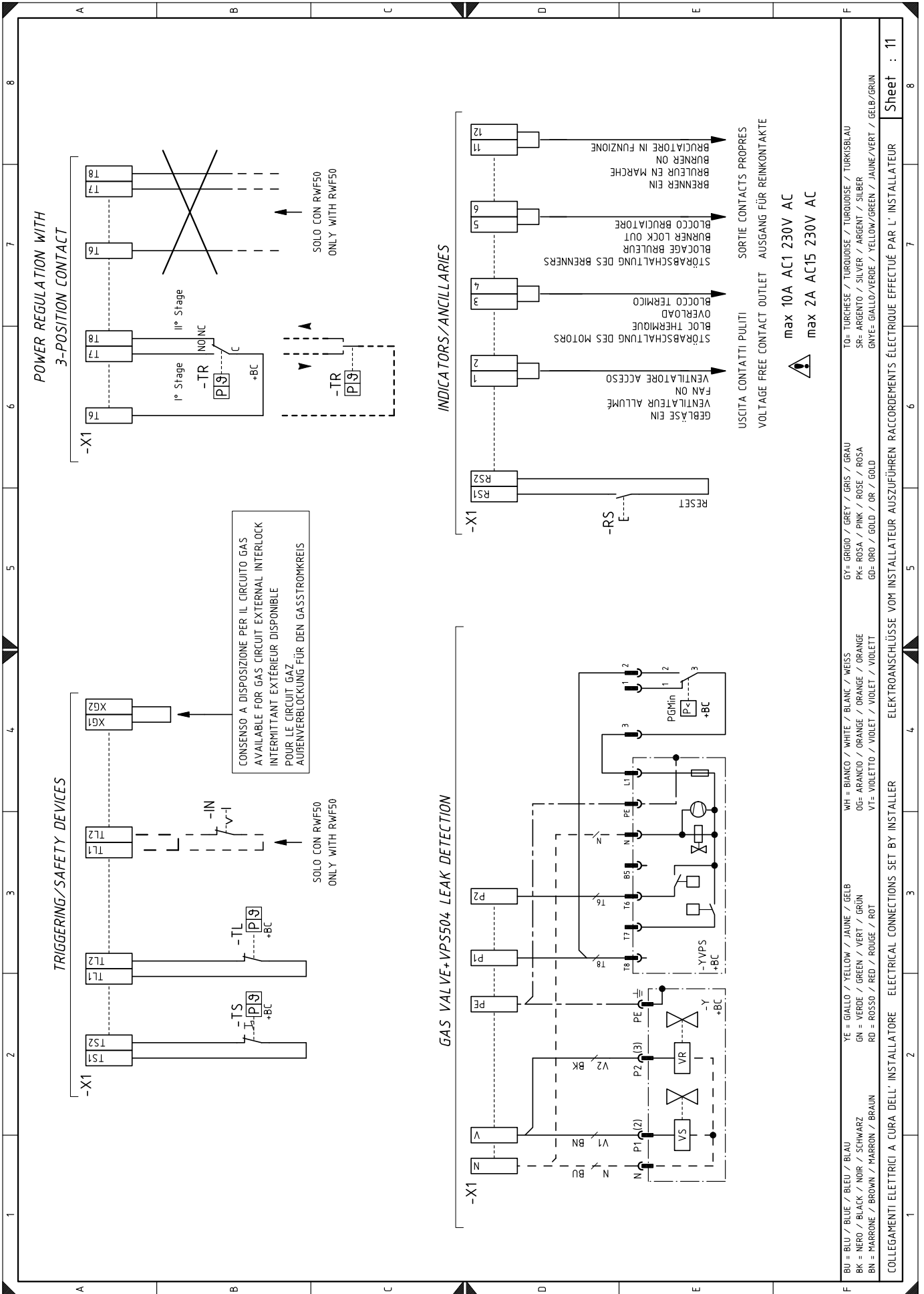



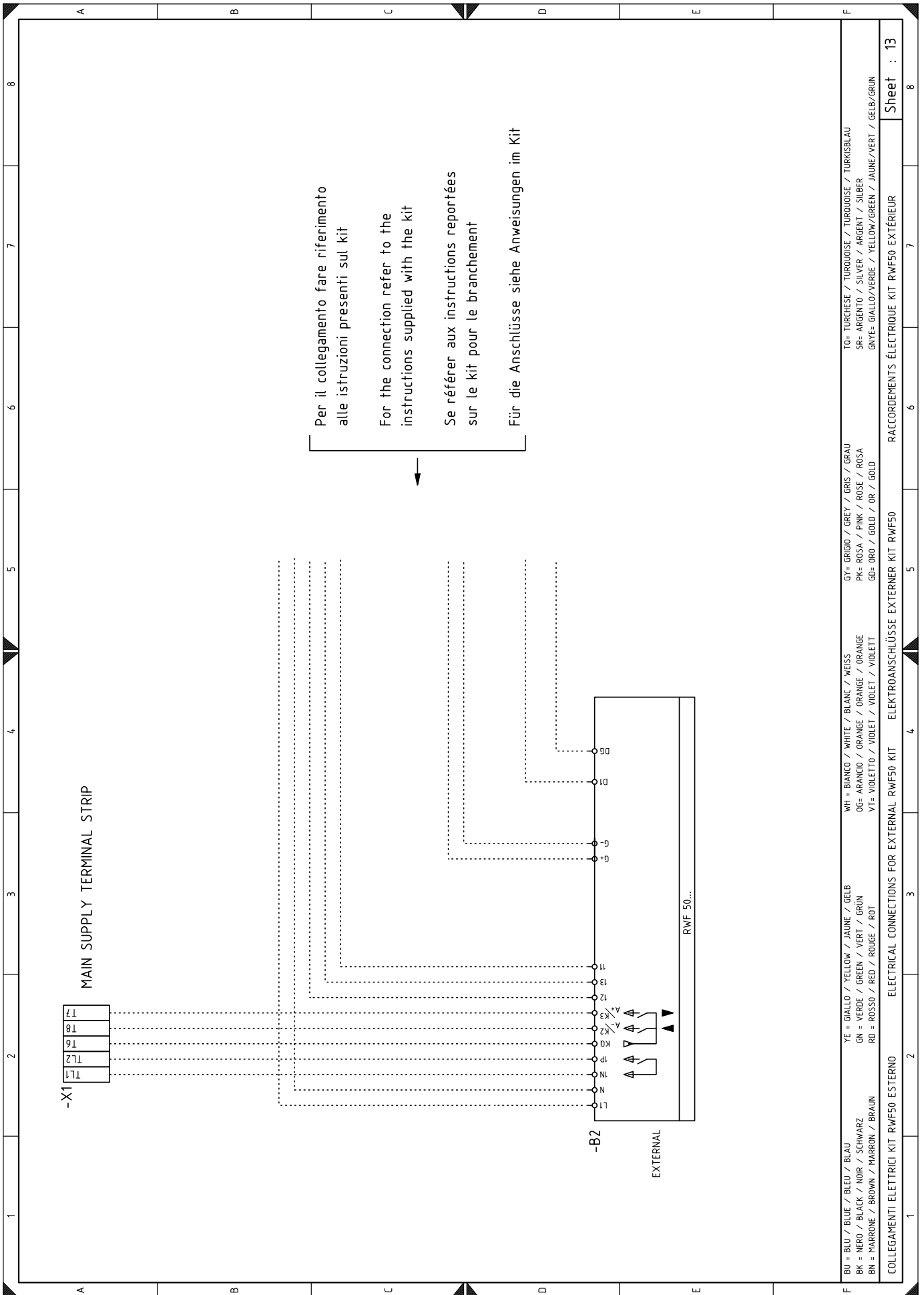

BU = BLU / BLUE / BLEU / BLAU  
 BK = NERO / BLACK / NOIR / SCHWARZ  
 BN = MARRONE / BROWN / MARRON / BRAUN  
 YE = GIALLO / YELLOW / JAUNE / GELB  
 GN = VERDE / GREEN / VERT / GRÜN  
 RD = ROSSO / RED / ROUGE / ROT  
 WH = BIANCO / WHITE / BLANC / WEISS  
 OG= ARANCIO / ORANGE / ORANGE / ORANGE  
 VT= VIOLETTA / VIOLET / VIOLET / VIOLETT  
 GY= GRIGIO / GREY / GRIS / GRAU  
 PK= ROSA / PINK / ROSE / ROSA  
 GO= ORO / GOLD / OR / GOLD  
 WH= BIANCO / WHITE / BLANC / WEISS  
 OG= ARANCIO / ORANGE / ORANGE / ORANGE  
 VT= VIOLETTA / VIOLET / VIOLET / VIOLETT  
 GY= GRIGIO / GREY / GRIS / GRAU  
 PK= ROSA / PINK / ROSE / ROSA  
 GO= ORO / GOLD / OR / GOLD  
 TO= TURCHESE / TURQUOISE / TURQUOISE / TURKISBLAU  
 SR= ARGENTO / SILVER / ARGENT / SILBER  
 GNVE= GIALLO/VERDE / YELLOW/GREEN / JAUNE/VERT / GELB/GRÜN

COLLEGAMENTI ELETTRICI KIT RWF50 ESTERNO      ELECTRICAL CONNECTIONS FOR EXTERNAL RWF50 KIT      ELEKTROANSCHLÜSSE EXTERNER KIT RWF50      RACCORDEMENTS ÉLECTRIQUE KIT RWF50 EXTÉRIEUR

Sheet : 13

### Wiring layout key

A5	Flame control	XPGM	Maximum gas pressure switch connector
B1	Output regulator RWF50 internal	XRWF	Output power regulator RWF terminal board
B2	Output regulator RWF50 external	XS	Flame sensor connector
BA	Output probe in current	XSM	Servomotor connector
BA1	Output device in current to modify remote setpoint	XVP1	VP1 connector
BP	Pressure probe	XVP2	VP2 connector
BP1	Pressure probe	Y	Gas adjustment valve + gas safety valve
BR	Remote setpoint potentiometer	YVPS	Valve leak detection device
BT1	Thermocouple probe		
BT2	Probe Pt100, 2 wires		
BT3	Probe Pt100, 3 wires		
BT4	Probe Pt100, 3 wires		
BTEXT	External probe for climatic compensation of the setpoint		
BV	Output probe in voltage		
BV1	Output device in voltage to modify remote setpoint		
FU	Fuses for three-phase line		
F1	Fan motor thermal relay		
F3	Auxiliary fuse		
H1	Light signalling burner on		
H2	Light signalling fan motor lockout and pump motor		
H3	Heat request lighting signal		
H4	Gas supply light signalling		
IN	Switch for manual shut-off burner		
KL1	Star/triangle starter line contactor and direct start-up		
KT1	Star/triangle starter triangle contactor		
KS1	Star/triangle starter star contactor		
KST1	Star/triangle starter timer		
K1	Clean contacts output relay with fan motor working		
K2	Clean contacts output relay motor lockout		
K3	Clean contacts output relay for burner lockout		
K6	Clean contacts output relay burner switched on		
MV	Fan motor		
PA	Air pressure switch		
PE	Burner earth		
PGMax	Maximum gas pressure switch		
PGMin	Minimum gas pressure switch		
RS	Remote burner reset button		
S1	Emergency stop button		
S2	Off / automatic / manual selector		
S4	Power increase / power reduction selector		
SH3	Burner reset button and lock-out signal		
SM	Servomotor		
TA	Ignition transformer		
TL	Limit thermostat/pressure switch		
TR	Adjustment thermostat/pressure switch		
TS	Safety thermostat/pressure switch		
UV	Flame sensor		
VP1	Pilot valve 1		
VP2	Pilot valve 2		
X1	Main terminal supply board		
X2	Terminal board for kit RWF50		
XAUX	Auxiliary terminal board		

---

**RIELLO**

RIELLO S.p.A.  
I-37045 Legnago (VR)  
Tel: +39.0442.630111  
[http:// www.riello.it](http://www.riello.it)  
[http:// www.riello.com](http://www.riello.com)