

GB **Forced draught gas burners**

Progressive two-stage or modulating operation

CE
UK
CA
EAC



CODE	MODEL	TYPE
20096670	BS1/M	915M
3762250 - 20052610	BS2/M	916M
3762350 - 3762370	BS3/M	917M
3762450	BS4/M	918M



Translation of the original instructions

1	Declarations	3
2	Information and general warnings	4
2.1	Information about the instruction manual	4
2.1.1	Introduction	4
2.1.2	General dangers	4
2.1.3	Other symbols	4
2.1.4	Delivery of the system and the instruction manual	5
2.2	Guarantee and responsibility	5
3	Safety and prevention	6
3.1	Introduction	6
3.2	Personnel training	6
4	Technical description of the burner	7
4.1	Burner designation	7
4.2	Models available	7
4.3	Burner categories - Countries of destination	7
4.4	Technical data	8
4.5	Electrical data	8
4.6	Maximum dimensions	9
4.7	Firing rates	9
4.8	Test boiler	11
4.8.1	Commercial boilers	11
4.9	Burner description	11
4.10	Burner equipment	11
4.11	Flame control (LME22.2...)	12
4.12	Servomotor (SQN91.57)	13
5	Installation	14
5.1	Notes on safety for the installation	14
5.2	Instructions to avoid burnout or bad combustion of the burner	14
5.3	Handling	14
5.4	Preliminary checks	14
5.4.1	Control of the supply	14
5.4.2	Control of burner characteristics	15
5.5	Operating position	15
5.6	Securing the burner to the boiler	16
5.7	Combustion head adjustment	17
5.7.1	Removing the head assembly	17
5.7.2	Reassembling the head assembly	17
5.8	Positioning the probe - electrode	18
5.9	Gas feeding	19
5.9.1	Gas feeding line	19
5.9.2	Connection of the burner pressure test point to the gas train	19
5.9.3	Gas train	20
5.9.4	Gas pressure	20
5.10	Electrical wiring	21
5.10.1	Electrical system carried out by the factory	22
5.10.2	Electrical wiring to be carried out by the installer	23
6	Start-up, calibration and operation of the burner	24
6.1	Notes on safety for the first start-up	24
6.2	Adjustments prior to ignition	24
6.3	First ignition	24
6.4	Air damper servomotor adjustment	25
6.5	Gas pressure switch	26
6.6	Air pressure switch	26
6.7	Combustion adjustment	26
6.8	Operation sequence of the burner	27

7	Maintenance	28
7.1	Notes on safety for the maintenance	28
7.2	Maintenance programme	28
7.2.1	Maintenance frequency.....	28
7.2.2	Safety test - with gas ball valve closed	28
7.2.3	Checking and cleaning.....	28
7.3	Opening the burner	29
8	Faults - Possible causes - Solutions.....	30
A	Appendix - Accessories	31

1 Declarations

Declaration of Conformity A.R. 8/1/2004 & 17/7/2009 – Belgium

Manufacturer/Distributed by: RIELLO S.p.A.
37045 Legnago (VR) Italy
Tel. ++39.0442630111
www.riello.com

This document certifies that the series of devices specified below is in compliance with the model described in the EC Declaration of Conformity and has been manufactured and distributed in compliance with the requirements defined in the Legislative Decree of January 8th 2004 and July 17th 2009.

Type of product: Forced draught gas burner
Model: BS1/M - BS2/M - BS3/M - BS4/M
Regulation applied: EN 676 and A.R. of January 8th 2004 - July 17th 2009
Controlling organisation: Kiwa Cermet Italia S.p.A.
Via Treviso 32-34
I-31020 San Vendemiano (TV)

Values measured:	BS1/M	Max. CO:	9 mg/kWh
		Max. NOx:	58 mg/kWh
	BS2/M	Max. CO:	9 mg/kWh
		Max. NOx:	58 mg/kWh
	BS3/M	Max. CO:	8 mg/kWh
		Max. NOx:	48 mg/kWh
	BS4/M	Max. CO:	5 mg/kWh
		Max. NOx:	53 mg/kWh

2 Information and general warnings

2.1 Information about the instruction manual

2.1.1 Introduction

The instruction manual supplied with the burner:

- is an integral and essential part of the product and must not be separated from it; it must therefore be kept carefully for any necessary consultation and must accompany the burner even if it is transferred to another owner or user, or to another system. If the manual is lost or damaged, another copy must be requested from the Technical Assistance Service of the area;
- is designed for use by qualified personnel;
- offers important indications and instructions relating to the installation safety, start-up, use and maintenance of the burner.

Symbols used in the manual

In some parts of the manual you will see triangular DANGER signs. Pay great attention to these, as they indicate a situation of potential danger.

2.1.2 General dangers

The **dangers** can be of **3 levels**, as indicated below.



Maximum danger level!
This symbol indicates operations which, if not carried out correctly, cause serious injury, death or long-term health risks.



This symbol indicates operations which, if not carried out correctly, may cause serious injury, death or long-term health risks.



This symbol indicates operations which, if not carried out correctly, may cause damage to the machine and/or injury to people.

2.1.3 Other symbols



DANGER: LIVE COMPONENTS
This symbol indicates operations which, if not carried out correctly, lead to electric shocks with lethal consequences.



DANGER: FLAMMABLE MATERIAL
This symbol indicates the presence of flammable materials.



DANGER: BURNING
This symbol indicates the risks of burns due to high temperatures.



DANGER: CRUSHING OF LIMBS
This symbol indicates the presence of moving parts: danger of crushing of limbs.



WARNING: MOVING PARTS
This symbol indicates that you must keep limbs away from moving mechanical parts; danger of crushing.



DANGER: EXPLOSION
This symbol signals places where an explosive atmosphere may be present. An explosive atmosphere is defined as a mixture - under atmospheric conditions - of air and flammable substances in the form of gases, vapours, mist or dust in which, after ignition has occurred, combustion spreads to the entire unburned mixture.



PERSONAL PROTECTION EQUIPMENT
These symbols indicate the equipment that must be worn and kept by the operator for protection against threats against safety and/or health while at work.



OBLIGATION TO ASSEMBLE THE COVER AND ALL THE SAFETY AND PROTECTION DEVICES
This symbol signals the obligation to reassemble the cover and all the safety and protection devices of the burner after any maintenance, cleaning or checking operations.



ENVIRONMENTAL PROTECTION
This symbol gives indications for the use of the machine with respect for the environment.



IMPORTANT INFORMATION
This symbol indicates important information that you must bear in mind.

- This symbol indicates a list.

Abbreviations used

Ch.	Chapter
Fig.	Figure
Page	Page
Sec.	Section
Tab.	Table

2.1.4 Delivery of the system and the instruction manual

When the system is delivered, it is important that:

- the instruction manual is delivered to the user by the system manufacturer, with the recommendation to keep it in the room where the heat generator is to be installed.
- The instruction manual shows:
 - the serial number of the burner;

.....

- the address and telephone number of the nearest Assistance Centre;

.....

- The system supplier must carefully inform the user about:
 - the use of the system;
 - any further tests that may be required before activating the system;
 - maintenance, and the need to have the system checked at least once a year by a representative of the manufacturer or another specialised technician. To ensure a periodic check, the manufacturer recommends the drawing up of a Maintenance Contract.

2.2 Guarantee and responsibility

The manufacturer guarantees its new products from the date of installation, in accordance with the regulations in force and/or the sales contract. At the moment of the first start-up, check that the burner is integral and complete.



WARNING

Failure to observe the information given in this manual, operating negligence, incorrect installation and carrying out of non authorised modifications will result in the annulment by the manufacturer of the guarantee that it supplies with the burner.

In particular, the rights to the guarantee and the responsibility will no longer be valid, in the event of damage to things or injury to people, if such damage/injury was due to any of the following causes:

- incorrect installation, start-up, use and maintenance of the burner;
- improper, incorrect or unreasonable use of the burner;
- intervention of unqualified personnel;
- carrying out of unauthorised modifications on the equipment;
- use of the burner with safety devices that are faulty, incorrectly applied and/or not working;
- installation of untested supplementary components on the burner;
- powering of the burner with unsuitable fuels;
- faults in the fuel supply system;
- continuation of use of the burner when a fault has occurred;
- repairs and/or overhauls incorrectly carried out;
- modification of the combustion chamber with inserts that prevent the regular development of the structurally established flame;
- insufficient and inappropriate surveillance and care of those burner components most likely to be subject to wear and tear;
- use of non-original components, including spare parts, kits, accessories and optional;
- force majeure.

The manufacturer furthermore declines any and every responsibility for the failure to observe the contents of this manual.

3 Safety and prevention

3.1 Introduction

The burners have been designed and built in compliance with current regulations and directives, applying the known technical rules of safety and envisaging all the potential danger situations.

It is necessary, however, to bear in mind that the imprudent and clumsy use of the equipment may lead to situations of death risk for the user or third parties, as well as the damaging of the burner or other items. Inattention, thoughtlessness and excessive confidence often cause accidents; the same applies to tiredness and sleepiness.

It is a good idea to remember the following:

- The burner must only be used as expressly described. Any other use should be considered improper and therefore dangerous.

In particular:

it can be applied to boilers operating with water, steam, diathermic oil, and to other uses expressly foreseen by the manufacturer;

the type and pressure of the fuel, the voltage and frequency of the electrical power supply, the minimum and maximum deliveries for which the burner has been regulated, the pressurisation of the combustion chamber, the dimensions of the combustion chamber and the room temperature must all be within the values indicated in the instruction manual.

- Modification of the burner to alter its performance and destinations is not allowed.
- The burner must be used in exemplary technical safety conditions. Any disturbances that could compromise safety must be quickly eliminated.
- Opening or tampering with the burner components is not allowed, apart from the parts requiring maintenance.
- Only those parts envisaged by the manufacturer can be replaced.



The manufacturer guarantees safety and proper functioning only if all burner components are intact and positioned correctly.

3.2 Personnel training

The user is the person, body or company that has acquired the machine and intends to use it for the specific purpose. He is responsible for the machine and for the training of the people working around it.

The user:

- undertakes to entrust the machine exclusively to suitably trained and qualified personnel;
- undertakes to inform his personnel in a suitable way about the application and observance of the safety instructions. With that aim, he undertakes to ensure that everyone knows the use and safety instructions for his own duties.
- Personnel must observe all the danger and caution indications shown on the machine.
- Personnel must not carry out, on their own initiative, operations or interventions that are not within their province.
- Personnel must inform their superiors of every problem or dangerous situation that may arise.
- The assembly of parts of other makes, or any modifications, can alter the characteristics of the machine and hence compromise operating safety. The manufacturer therefore declines any and every responsibility for any damage that may be caused by the use of non-original parts.

In addition:



- must take all the measures necessary to prevent unauthorised people gaining access to the machine;
- the user must inform the manufacturer if faults or malfunctioning of the accident prevention systems are noticed, along with any presumed danger situation;
- personnel must always use the personal protective equipment envisaged by legislation and follow the indications given in this manual.

4 Technical description of the burner

4.1 Burner designation

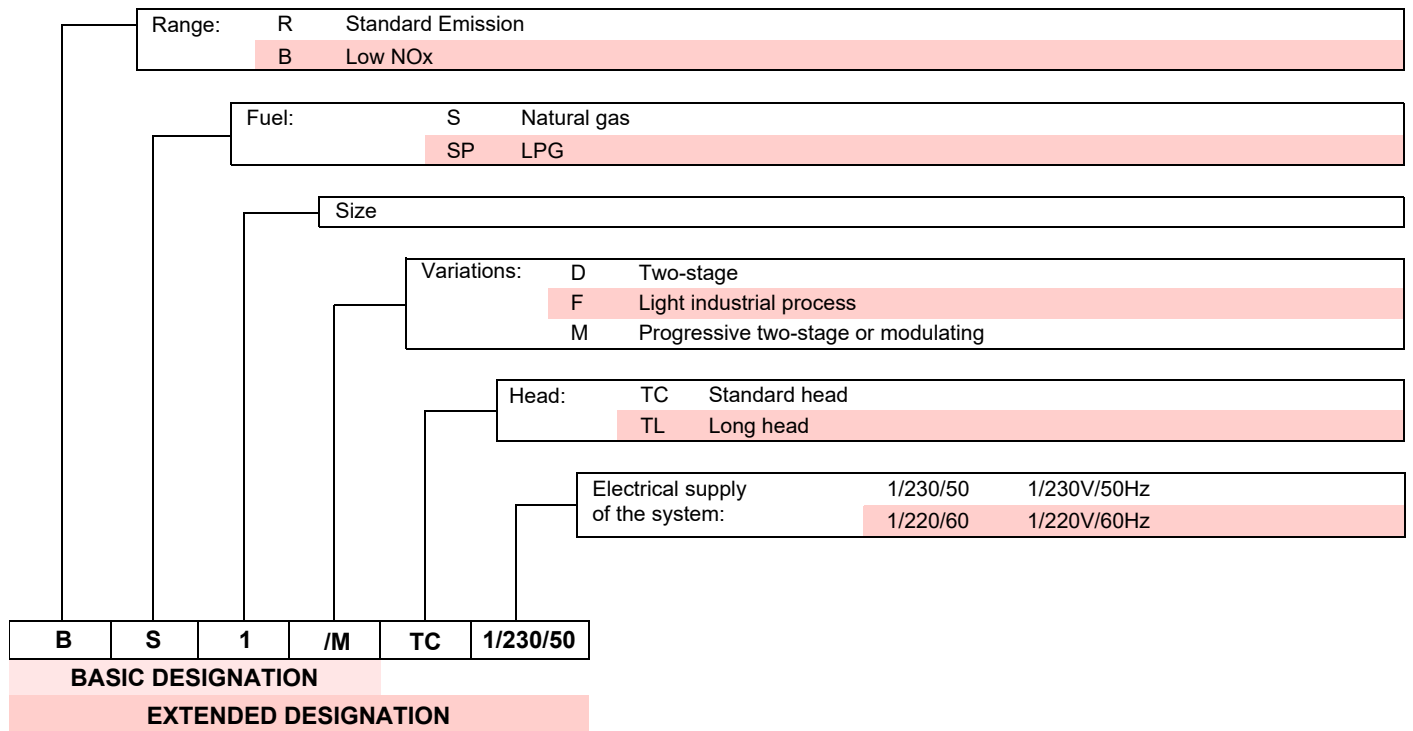

4.2 Models available

Designation	Combustion head	Voltage	Code
BS1/M	TC	1/230/50	20096670
BS2/M	TC	1/230/50	3762250
BS2/M	TL	1/230/50	20052610
BS3/M	TC	1/230/50	3762350
BS3/M	TL	1/230/50	3762370
BS4/M	TC	1/230/50	3762450

Tab. A

4.3 Burner categories - Countries of destination

Country of destination	Gas category
SE - FI - AT - GR - DK - ES - GB - IT - IE - PT - IS - CH - NO	I ₂ H
DE	I ₂ ELL
NL	I ₂ EK
FR	I ₂ Er
BE	I ₂ E(R)B
LU - PL	I ₂ E

Tab. B

4.4 Technical data

Type		915M	916M	917M	918M
Thermal output ⁽¹⁾	kW	16/19 - 52	26/49 - 91	48/79 - 195	68/140 - 250
	Mcal/h	13.8/16.4 - 44.7	22.4/42.1 - 78.2	41.3/67.9 - 167.7	58.5/120.4 - 215
Natural gas (Family 2)		NCV: 8 - 12 kWh/Nm ³ = 7000 - 10.340 kcal/Nm ³ Pressure: min. 20 mbar – max. 100 mbar *			
Operation		Intermittent (FS1)			
Use		Boilers: water and diathermic oil			
Ambient temperature	°C	0 - 50			
Combustion air temperature	°C max	60			
Noise levels ⁽²⁾	Sound pressure	59	60	65	67
	Sound power	70	71	76	78
Weight	kg	11	12	16	20
CE	No.	CE-0476DP3336			

Tab. C

(1) Reference conditions: Ambient temperature 20°C - Gas temperature 15°C - Barometric pressure 1013 mbar - Altitude 0 m a.s.l.

(2) Sound pressure measured in manufacturer's combustion laboratory, with burner operating on test boiler and at maximum output. The sound power is measured with the "Free Field" method, as per EN 15036, and according to an accurate "Accuracy: Category 3" measurement, as described in EN ISO 3746.



WARNING

* Δp between the input and output pressure max. 50 mbar.

4.5 Electrical data

Type		915M	916M	917M	918M
Electrical supply		1/230V/50Hz			
Absorbed electrical power	kW	0.14	0.18	0.35	0.53
Protection level		IP40			

Tab. D

4.6 Maximum dimensions

The maximum dimensions of the flange and burner are given in Fig. 1.

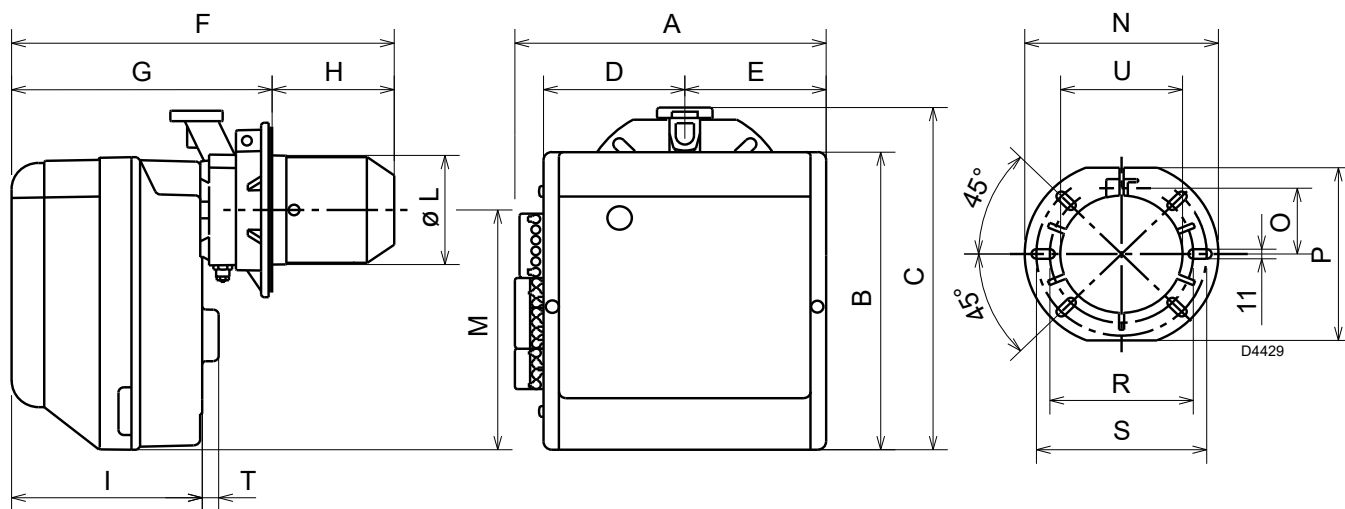

Fig. 1

Model	A	B	C	D	E	F	G	H	I	L-U	M	N	O	P	R	S	T
BS1/M TC	285	280	316	125.5	125.5	351	234.5	116.5	174	89.5	230	192	66	167	140	170	8
BS2/M TC	285	280	325	125.5	125.5	352	238÷252	114÷100	174	106	230	192	66	167	140	170	18
BS2/M TL						422		184÷170									
BS3/M TC	330	345	391	150	150	390	262÷280	128÷110	196	129	285	216	76.5	201	160	190	21
BS3/M TL						547		285÷267									
BS4/M TC	330	345	392	150	150	446	278÷301	168÷145	212	137	286	218	80.5	203	170	200	21

Tab. E

4.7 Firing rates

The burner output is chosen from within the diagram area (Fig. 3).



To ensure the burner works correctly, the start-up should always occur within the relative firing rate, as indicated in .



Only for models BS3/M and BS4/M

It is necessary to remove the sound-absorbing pre-sheared part freeing the air inlet slots on the cover (see Fig. 2), in order to ensure the burner operates beyond the burner output indicated in Tab. G.

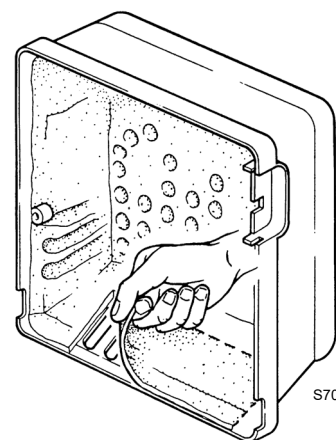

S7025

Fig. 2

Model	Ignition output (kW)
BS1/M	16 - 19
BS2/M	26 - 49
BS3/M	48 - 79
BS4/M	68 - 140

Tab. F



The firing rates (Fig. 3) were obtained at an ambient temperature of 20 °C, at a barometric pressure of 1013 mbar (about 0 m a.s.l.) and with the combustion head regulated as indicated on page 17.

Model	A
BS3/M	> 140 kW
BS4/M	> 200 kW

Tab. G

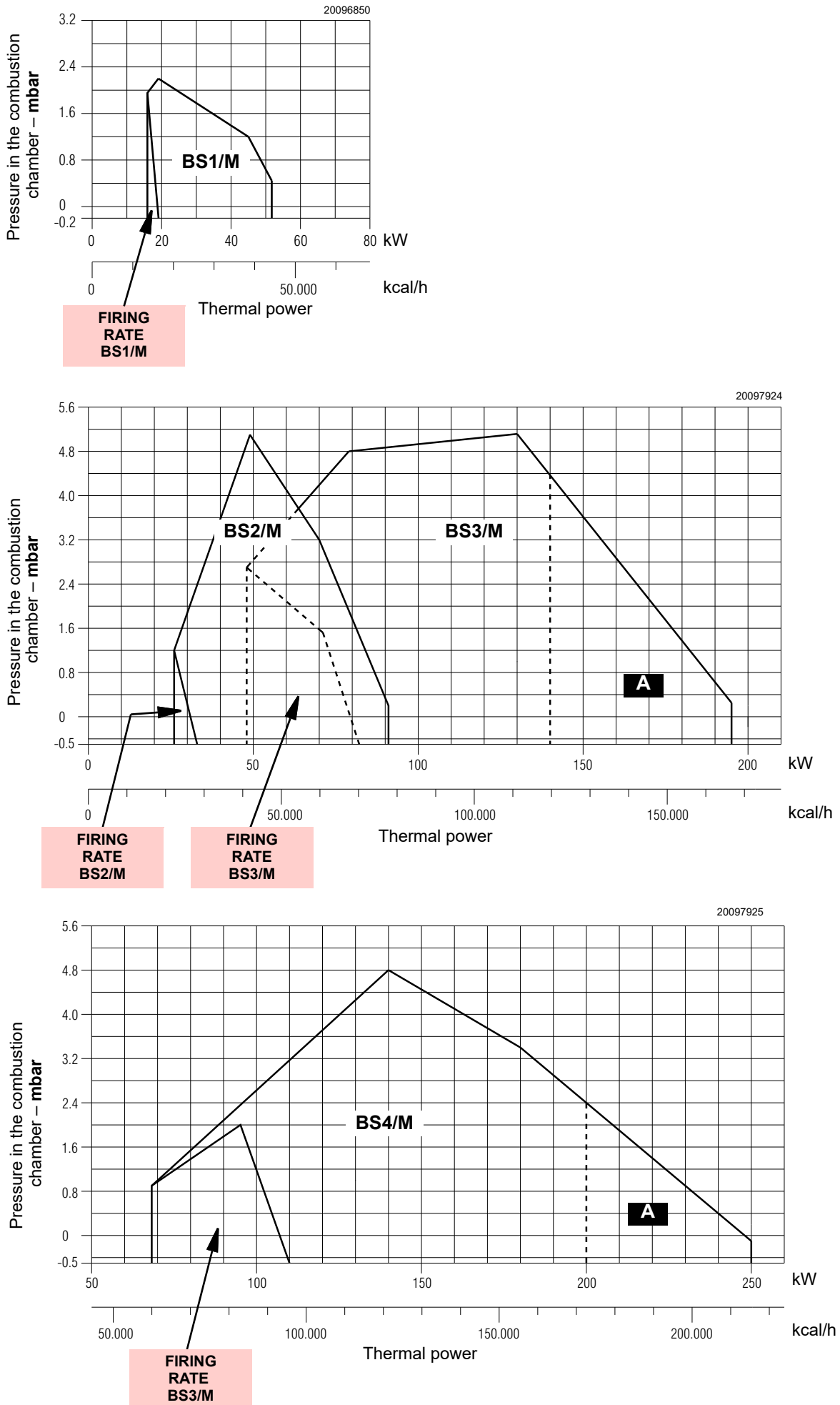

Fig. 3

4.8 Test boiler

The firing rate has been defined according to EN 676 standard.

For applications where the boiler does not conform to EN 303, or where the combustion chamber is much smaller than the dimensions given in EN 676, please consult the manufacturers.

4.8.1 Commercial boilers

The burner-boiler matching is assured if the boiler conforms to EN 303 and the combustion chamber dimensions are similar to those shown in the diagram EN 676.

4.9 Burner description

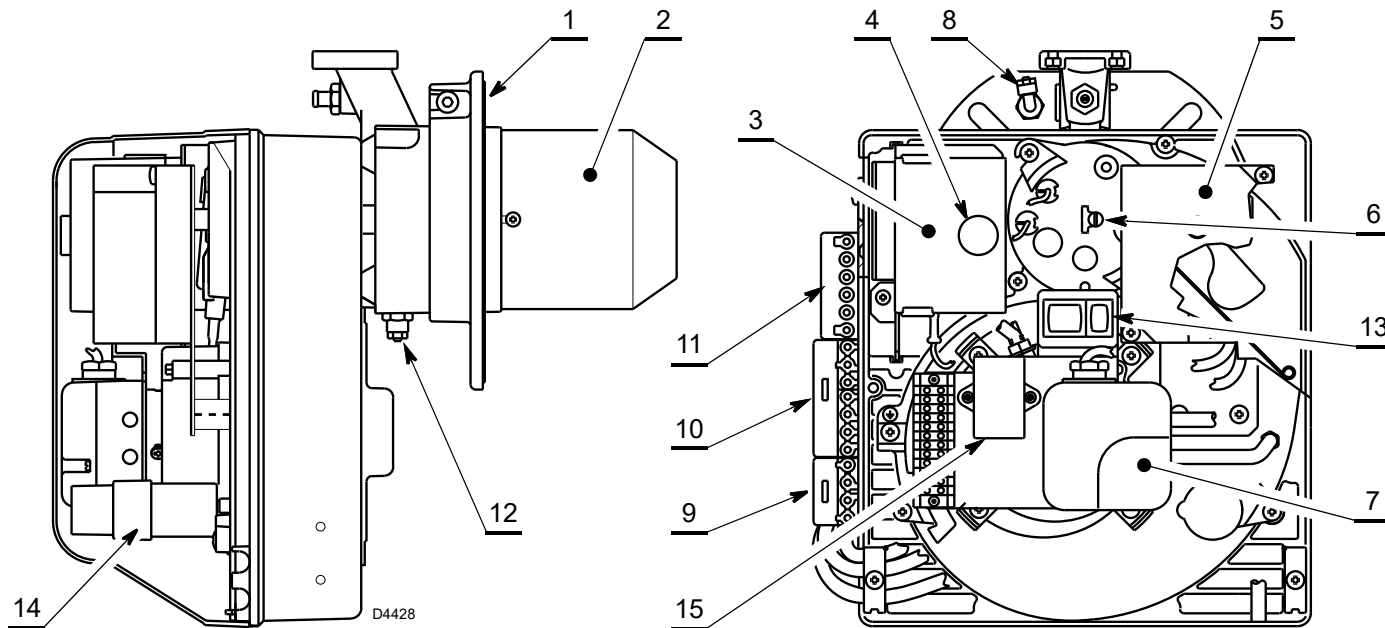

Fig. 4

- | | |
|--|--|
| <ul style="list-style-type: none"> 1 Flange with insulating gasket 2 Combustion head 3 Flame control 4 Reset button with lockout lamp 5 Servomotor unit 6 Combustion head adjustment screw 7 Air pressure switch 8 Air pressure test point in the combustion chamber (to be connected to the gas valve unit) | <ul style="list-style-type: none"> 9 4-pole socket for 2nd stage / modulating connection 10 7-pole socket for burner power supply 11 6-pole socket for train connection 12 Air pressure test point (to be connected to the gas valve unit) 13 Switches for: <ul style="list-style-type: none"> - automatic / manual (AUT / MAN) - raising / lowering output (+/-) 14 Capacitor 15 Noise reduction filter |
|--|--|

4.10 Burner equipment

- | | |
|--|-------|
| Flange with insulating gasket | No. 1 |
| Elbow joint G 1/8 | No. 1 |
| Flange screws and nuts for boiler fixing | No. 4 |
| 4-pin plug | No. 1 |
| Screw and nut for flange | No. 1 |
| 7-pin plug - | No. 1 |
| Blue plastic pipe | No. 1 |
| Instructions | No. 1 |
| Spare parts list | No. 1 |

4.11 Flame control (LME22.2...)

Warnings



To avoid accidents, material or environmental damage, observe the following instructions!

The flame control is a safety device! Avoid opening or modifying it, or forcing its operation. Riello S.p.A. cannot assume any responsibility for damage resulting from unauthorised interventions!

- All interventions (assembly and installation operations, assistance, etc.) must be carried out by qualified personnel.
- Before modifying the wiring in the flame control connection area, fully disconnect the system from the power supply (omnipolar separation).
- Protection against electrocution from the flame control and all connected electric components is obtained with the correct assembly.
- Before any intervention (assembly and installation operations, assistance, etc.), ensure the wiring is in order and that the parameters are correctly set, then make the safety checks.
- Falls and collisions can negatively affect the safety functions. In this case, the flame control must not be operated, even if it displays no evident damage.

For safety and reliability, comply with the following instructions:

- avoid conditions that can favour the development of condensate and humidity. Otherwise, before switching on again, make sure the flame control is perfectly dry.
- Static charges must be avoided since they can damage the flame control's electronic components when touched.

Use

The flame control is a control and supervision system of medium and large capacity forced draught burners, for intermittent operation (at least one controlled shutdown every 24 hours).

Installation notes

- Check the electric wiring inside the boiler complies with the national and local safety regulations.
- Install switches, fuses, earth connection etc. in compliance with local regulations.
- Do not confuse the powered conductors with the neutral ones.
- Ensure that spliced wires cannot get into contact with neighbouring terminals. Use adequate ferrules.
- Arrange the H.V. ignition cables separately, as far as possible from the flame control and the other cables.
- When wiring the unit, make sure the 230V AC mains voltage cables are run strictly separate from extra low-voltage cables, to avoid the risk of electrocution.



S9255

Fig. 5

Electrical wiring of the flame detector

It is important for signal transmission to be almost totally free of any disturbances or loss:

- Always separate the detector cables from the other cables:
 - the line capacity reduces the magnitude of the flame signal;
 - use a separate cable.
- The cable length must not exceed 1 m.
- Respect the polarity
- Insulation resistance:
 - must be at least 50 MΩ between the ionisation probe and the earth;
 - a dirty detector reduces the insulation resistance, fostering leakage currents.
- The ionisation probe is not protected against the risk of electrocution. When connected to the electricity supply, the ionisation probe must be protected against any accidental contact.
- Position the ionisation probe so that the ignition spark cannot form an arc on the probe (risk of electric overcharge).

Technical data

Mains voltage	AC 230V -15% / +10%
Mains frequency	50/60 Hz ±6%
Built-in fuse	T6.3H 250V
Energy consumption	12 VA
Weight	approx. 160 g
Protection level	IP40
Safety class	I
Tightening torque of M4 screw	Max. 0,8 Nm
Allowed cable length	
Thermostat	max. 20 m at 100 pF/m
Air pressure switch	max. 1 m at 100 pF/m
CPI	max. 1 m at 100 pF/m
Gas pressure switch	max. 20 m at 100 pF/m
Flame detector	max. 1 m
Remote reset	max. 20 m at 100 pF/m
Environmental conditions	
Storage	DIN EN 60721-3-1
Climatic conditions	Class 1K3
Mechanical conditions	Class 1M2
Temperature range	-20...+60°C
Humidity	< 95% RH

Tab. H

4.12 Servomotor (SQN91.57)

Warnings



To avoid accidents, material or environmental damage, observe the following instructions!

Avoid opening, modifying or forcing the actuators.

- All interventions (assembly and installation operations, assistance, etc.) must be carried out by qualified personnel.
- Before modifying the wiring in the connection area of the servomotor, fully disconnect the burner control device from the power supply (omnipolar separation).
- To avoid the risk of electrocution, protect the connection terminals in a suitable manner and correctly fix the cover.
- Check the wiring is in order.
- Falls and collisions can negatively affect the safety functions. In this case, the unit must not be operated, even if it displays no evident damage.

Assembly notes

- Check the relevant national safety standards are respected.
- The connection between the actuator command shaft and the control element must be rigid, without any mechanical play.
- To avoid an excessive load on the bearings due to rigid hubs, the use of compensation clutches without any mechanical play is recommended (e.g. metal bellows-type clutches).

Installation notes

- Arrange the H.V. ignition cables separately, as far as possible from the flame control and the other cables.
- To prevent the risk of electrocution, check that the 230V AC section of the servomotor is completely separated from the low voltage section.
- The static torque is reduced when the electrical supply of the actuator is switched off.
- The housing cover may only be removed for short periods of time for wiring or when making the addressing. In similar cases, make sure that dust or dirt does not penetrate inside the actuator.
- The actuator comprises a PCB with ESD-sensitive components.
- The top side of the board carries a cover which affords protection against direct contact. This protective cover must not be removed! The underside side of the board must not be touched.



During the maintenance or replacement of the actuators, be careful not to invert the connectors.

Technical data

Model	SQN91.57
Operating voltage	AC 220V -15 %...AC 240V +10 %
Mains frequency	50/60 Hz ±6%
Safety class	DIN EN 60730 compliant
Energy consumption	8 VA
Rotation direction	Clockwise
Holding torque	0.8...2.4 Nm
Operation time	4...24 s
Weight	Approx. 550 g
Environmental conditions:	
Operation	DIN EN 60721-3-3
Climatic conditions	Class 3K5
Mechanical conditions	Class 3M2
Temperature range	-20...+60°C
Humidity	< 95% RH

Tab. I



Condensation, the formation of ice and the entry of water are prohibited!

5 Installation

5.1 Notes on safety for the installation

After carefully cleaning all around the area where the burner is to be installed, and arranging for the environment to be illuminated correctly, proceed with the installation operations.



All the installation, maintenance and disassembly operations must be carried out with the electricity supply disconnected.



The installation of the burner must be carried out by qualified personnel, as indicated in this manual and in compliance with the standards and regulations of the laws in force.



Combustion air inside the boiler must be free from hazardous mixes (e.g.: chloride, fluoride, halogen); if present, it is highly recommended to carry out cleaning and maintenance more frequently.

5.2 Instructions to avoid burnout or bad combustion of the burner

- 1 The burner can not be installed outside as it is suitable for operation in closed rooms only.
- 2 The premises the burner operates in must have openings for the air need for the combustion. To be sure about this, you have to control CO₂ and CO in the exhaust gases with all the windows and doors closed.
- 3 If there are air extractors in the premises the burner works, make sure that there are openings for air to be taken in that

are big enough to ensure the required air change; In any case, check that when the burner stops the extractors do not draw hot fumes from pipes through the burner.

- 4 When the burner is stopped, the smoke pipe must be kept open and a natural draft created in the combustion chamber. If the smoke pipe is closed, the burner must be drawn back till the extraction of blast tube from the furnace. Before operating in this way take the voltage off.

5.3 Handling

The transport weight is given in chapter "Technical data" on page 8.

Observe the permissible ambient temperatures for storage and transport: -20 + 70 °C, with max. relative humidity. 80%.



After positioning the burner near the installation point, correctly dispose of all residual packaging, separating the various types of material.



Before proceeding with the installation operations, carefully clean all around the area where the burner will be installed.



The operator must use the required equipment during installation.

5.4 Preliminary checks

5.4.1 Control of the supply



After removing all the packaging, check the integrity of the contents.

In the event of doubt, do not use the burner; contact the supplier.



The packaging elements (cardboard box, clips, plastic bags, etc.) must not be abandoned as they are potential sources of danger and pollution; they should be collected and disposed of in the appropriate places.

5.4.2 Control of burner characteristics

Check the identification label of the burner (Fig. 6), showing:

- A the burner model;
- B the burner type;
- C the cryptographic year of manufacture;
- D the serial number;
- E the data for electrical supply and the protection level;
- F the electrical power consumption;
- G the data of the burner's minimum and maximum output possibilities (see Firing rate)

Warning. The burner output must be within the boiler's firing rate.



WARNING

A burner label that has been tampered with, removed or is missing, along with anything else that prevents the definite identification of the burner makes any installation or maintenance work difficult.



WARNING

The figure of the label (Fig. 6) is indicative. Some of the data may be arranged in a different position.

R.B.L.	A		TIPO TYP TYPE	B	B	C
I12ELL.3B/P DE	D		E		F	
I12H3B/P AT,CH,IS	I12H3 GB,IE,IT N2L3B/P LU	GAS GAZ	<input checked="" type="checkbox"/> FAM.2 <input type="checkbox"/> FAM.3		G	
I2E(P)B.13 BE I12L3B/P NL I12E3P FR	Icc Imax	A A	PESO	kg	RIELLO S.p.A. I-37048 Legnago (VR)	CE

20098188

Fig. 6

5.5 Operating position



WARNING

- The burner is set up to operate only in positions **1, 2, 3, 5, 6** and **7** (Fig. 7).
- Installation **1** is preferable, as it is the only one that allows the maintenance operations as described in this manual.
- The installation layout illustrated in position **5** is only possible using the "MULTI-BLOC rotation kit", to be ordered separately.



DANGER

- Any other position could compromise the correct operation of the appliance.
- Installation **4** are forbidden for safety reasons.

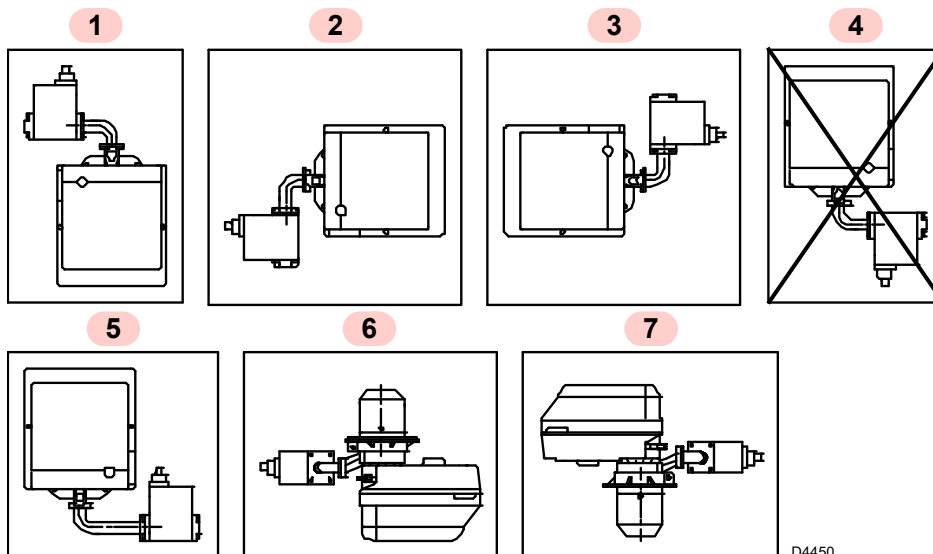

D4450

Fig. 7

5.6 Securing the burner to the boiler



Provide an adequate lifting system of the burner.

- If necessary, widen the insulating gasket holes (Fig. 8), taking care not to damage them.
- Put on the flange 5)(Fig. 10) the pressure test point 7) supplied with the burner.

The burner can be fixed with the variable position A) as shown in Fig. 9.

Model		A (mm)
BS1/M	TC	116 ÷ 70
BS2/M	TC	114 ÷ 100
BS2/M	TL	184 ÷ 170
BS3/M	TC	128 ÷ 110
BS3/M	TL	285 ÷ 267
BS4/M	TC	167.5 ÷ 145

Tab. J

- Fix the flange 5) to the door of the boiler 1)(Fig. 10) placing the insulating gasket 3) in between using the screws 4) and (if necessary) the nuts 2), but keeping one of the two top screws 4) loose.
- Insert the combustion head of the burner in the flange 5), tighten the flange with the screw 6), then lock the screw 4) which was loose.
- Check that the pressure test point 7) can actually measure the pressure in the chamber through the insulating gasket 3). If this signal is not secure, inert the socket directly connected to the combustion chamber (for example, through the pipe of the inspection window, if available).



CAUTION

The lack of connection to an effective pressure test point of the combustion chamber could lead to an unsafe operation and to possible ignition difficulties.



WARNING

In any event, make sure that the combustion head crosses the entire thickness of the boiler door.



WARNING

The seal between burner and boiler must be airtight.

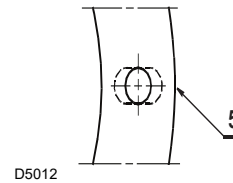

Fig. 8

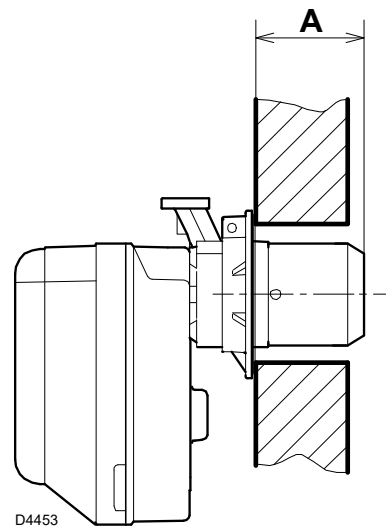

Fig. 9

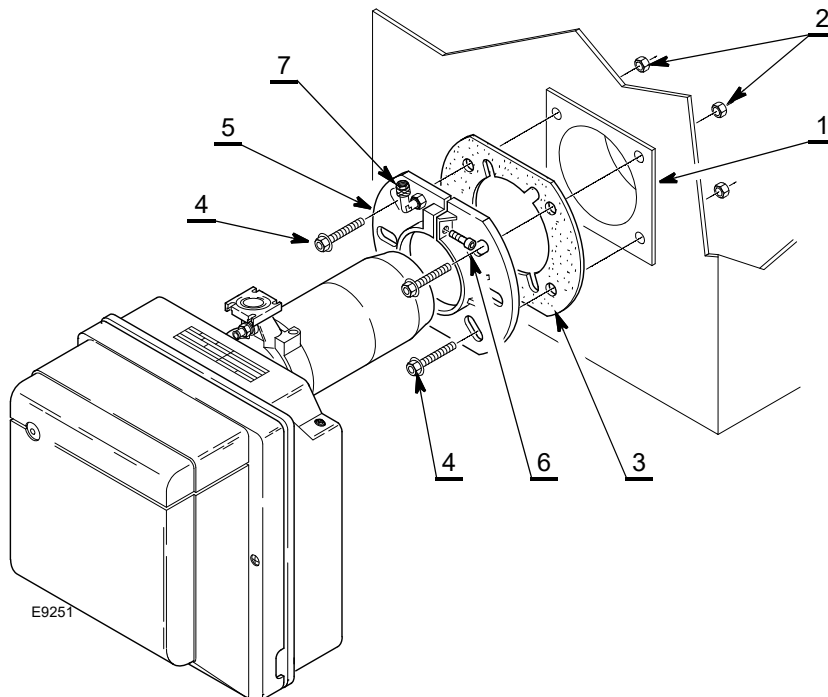

Fig. 10

5.7 Combustion head adjustment

The adjustment of the combustion head varies depending on the burner output.

This is carried out by turning the adjustment screw 6)(Fig. 11) clockwise or anti-clockwise until the notch on the regulating rod 2) lines up with the outside surface of the head assembly 1).

Fig. 11 shows the head regulating rod set on notch 3.5.

Example for the BS3/M burner

The diagram (Fig. 12) is indicative and shows the calibration of the combustion head in relation to the burnt output. To ensure the burner works efficiently, we suggest adjusting the combustion head according to the requirements of the specific boiler.

The burner is installed in a 100 kW boiler. Considering an efficiency of 90%, the burner must supply around 110 kW; for this burner output the adjustment should be on notch 3.5.

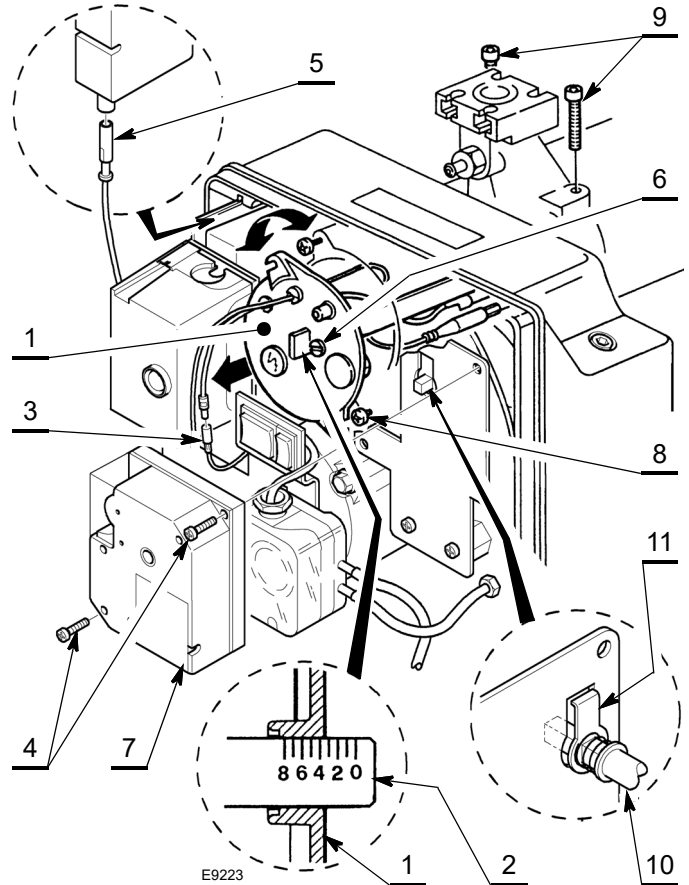

Fig. 11

5.7.1 Removing the head assembly

To remove the head assembly, it is necessary to:

- make sure that the servomotor 7)(Fig. 11) is in a closed position (**CAM II = 0**);
- disconnect the connections 3) and 5);
- unscrew the screws 4) and remove the servomotor 7).



WARNING

The rotating shaft 10)(Fig. 11) operated by the servomotor 7) is equipped with a safety mechanism 11) that prevents it from accidentally rotating during maintenance operations.

- Loosen the screws 9)(Fig. 11);
- loosen the screws 8) and remove the head assembly support 1) slightly rotating to the right.



CAUTION

Take care not to change the setting position on the elbow-bracket 2) when dismantling.

5.7.2 Reassembling the head assembly

Reverse the procedure above to put back the head assembly 1) as it was before.



CAUTION

Tighten the screws 9), without fully locking them. Lock them with a tightening torque of 3 - 4 Nm.



WARNING

Check that when operating there are no gas leaks from the screw housings.

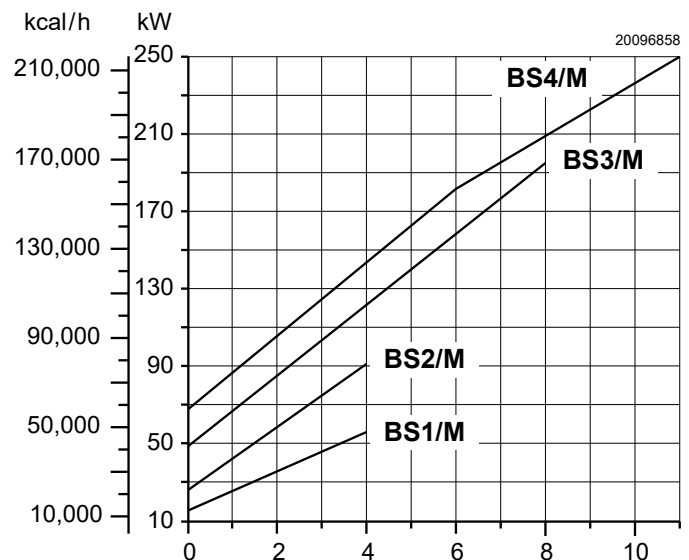

Fig. 12

5.8 Positioning the probe - electrode

- Make sure that the plate 3)(Fig. 13) is always inserted in the flattening of the electrode 1).
- Rest the probe insulator 4) against the air diffuser 2).



Respect the positions shown in Tab. K.

Model	A (mm) ± 0.3
BS1/M	30
BS2/M	30
BS3/M	31
BS4/M	31

Tab. K

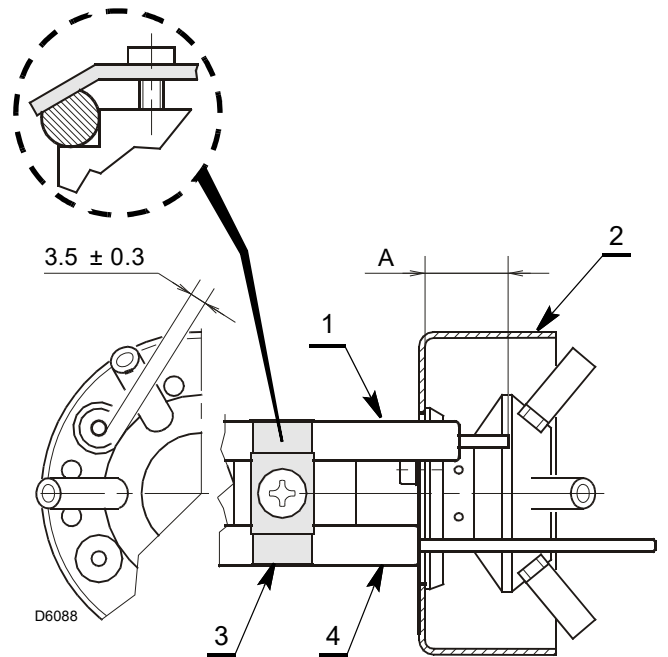

Fig. 13

5.9 Gas feeding



Explosion danger due to fuel leaks in the presence of a flammable source.

Precautions: avoid knocking, attrition, sparks and heat.

Make sure the fuel interception tap is closed before performing any operation on the burner.



The fuel supply line must be installed by qualified personnel, in compliance with current standards and laws.

5.9.1 Gas feeding line

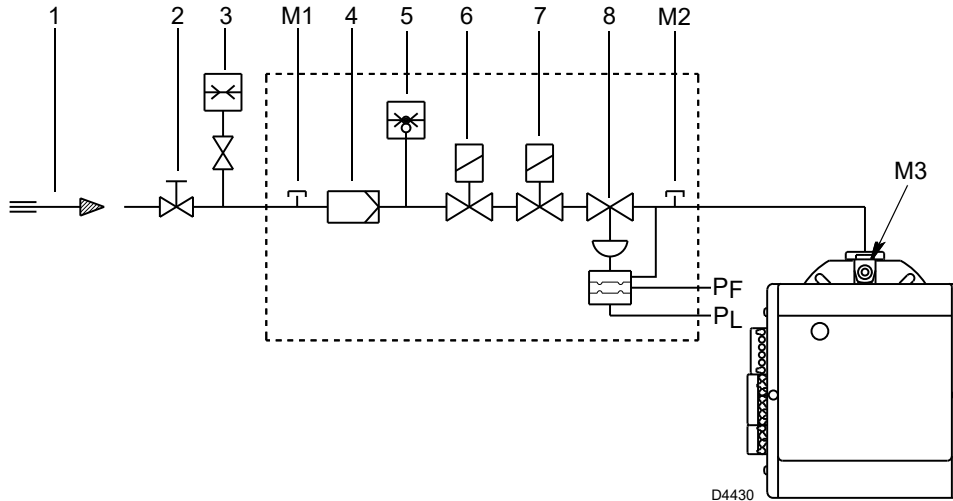

Fig. 14

Key (Fig. 14)

- 1 Gas input pipe
- 2 Manual gate *(under the responsibility of the installer)*
- 3 Gas pressure gauge *(under the responsibility of the installer)*
- 4 Filter
- 5 Gas pressure switch
- 6 Electromagnetic safety valve
- 7 Electromagnetic working valve
- 8 Pressure adjuster
- PF Pressure in combustion chamber
- PL Air pressure at combustion head
- M1 Gas supply pressure test point
- M2 Pressure point for gas measurement at gas train outlet
- M3 Pressure point for gas measurement at combustion head



It is necessary to maintain a brief path for pulse lines.

It is recommended that pulse lines not be rested against the boiler because of damage due to high temperatures.

- In some applications, where the measurement of the pressure in the combustion chamber is imprecise, the G1/8 connector must be shifted from the flange of the burner to the door of the boiler. In this case plug the hole of the flange.
- Ignoring this instruction can cause the valve to malfunction, and it could be damaged.

5.9.2 Connection of the burner pressure test point to the gas train

To carry out the connections proceed as follows:

- fix the G1/8 connector (supplied with the burner) at point A)(Fig. 15) (burner flange).
- Cut the blue plastic pipe supplied with the burner in two.
- Connect the boiler socket A) with the air intake "PF" and the pipe coupling socket B) with the valve socket "PL" using the pipes that were previously cut.
- The pipe that connects the valve socket "PF" to the boiler socket A should be positioned so that any condensation is drained into the combustion chamber and not inside the valve.

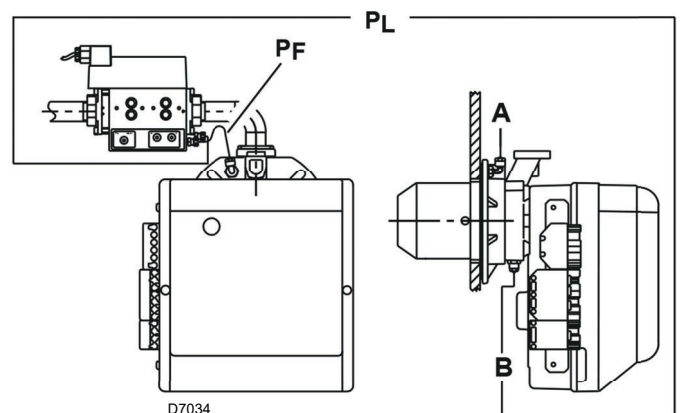

Fig. 15

5.10 Electrical wiring

Notes on safety for the electrical wiring



- The electrical wiring must be carried out with the electrical supply disconnected.
- Electrical wiring must be made in accordance with the regulations currently in force in the country of destination and by qualified personnel. Refer to the wiring diagrams.
- The manufacturer declines all responsibility for modifications or connections different from those shown in the wiring diagrams.
- Check that the electrical supply of the burner corresponds to that shown on the identification label and in this manual.
- The burner has been type-approved for intermittent use. In the event of continuous operation, a cycle arrest must be ensured within 24 hours with the use of a time switch positioned in series with the thermostatic line. Refer to the wiring diagrams.
- The electrical safety of the device is obtained only when it is correctly connected to an efficient earthing system, made according to current standards. It is necessary to check this fundamental safety requirement. In the event of doubt, have the electrical system checked by qualified personnel. Do not use the gas tubes as an earthing system for electrical devices.
- The electrical system must be suitable for the maximum power absorption of the device, as indicated on the label and in the manual, checking in particular that the section of the cables is suitable for that level of power absorption.
- For the main power supply of the device from the electricity mains:
 - do not use adapters, multiple sockets or extensions;
 - use a multiple pole switch with at least a 3 mm gap between the contacts (overvoltage category III), as envisaged by the present safety standards.
- Do not touch the device with wet or damp body parts and/or in bare feet.
- Do not pull the electric cables.

Before carrying out any maintenance, cleaning or checking operations:



Turn off the burner's power supply using the main system switch.



Turn off the fuel interception tap.



Avoid condensate, ice and water leaks from forming.

If the cover is still present, remove it and proceed with the electrical wiring according to the wiring diagrams.



After carrying out maintenance, cleaning or checking operations, reassemble the cover and all the safety and protection devices of the burner.

Testing

Check the burner stops by opening the thermostats and check it locks out by opening the connector (CN3)(Fig. 17) inserted in the probe's red wire, located on the outside of the flame control.

Ionisation current

The minimum current necessary for the flame control operation is 2 μ A. The burner normally supplies a higher current value, so that no check is needed.

In any event, if you want to measure the ionisation current, you need to open the connector (CN3)(Fig. 17) on the red wire and insert a microammeter.

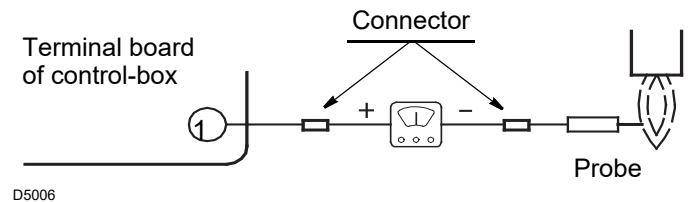

Fig. 16

5.10.1 Electrical system carried out by the factory

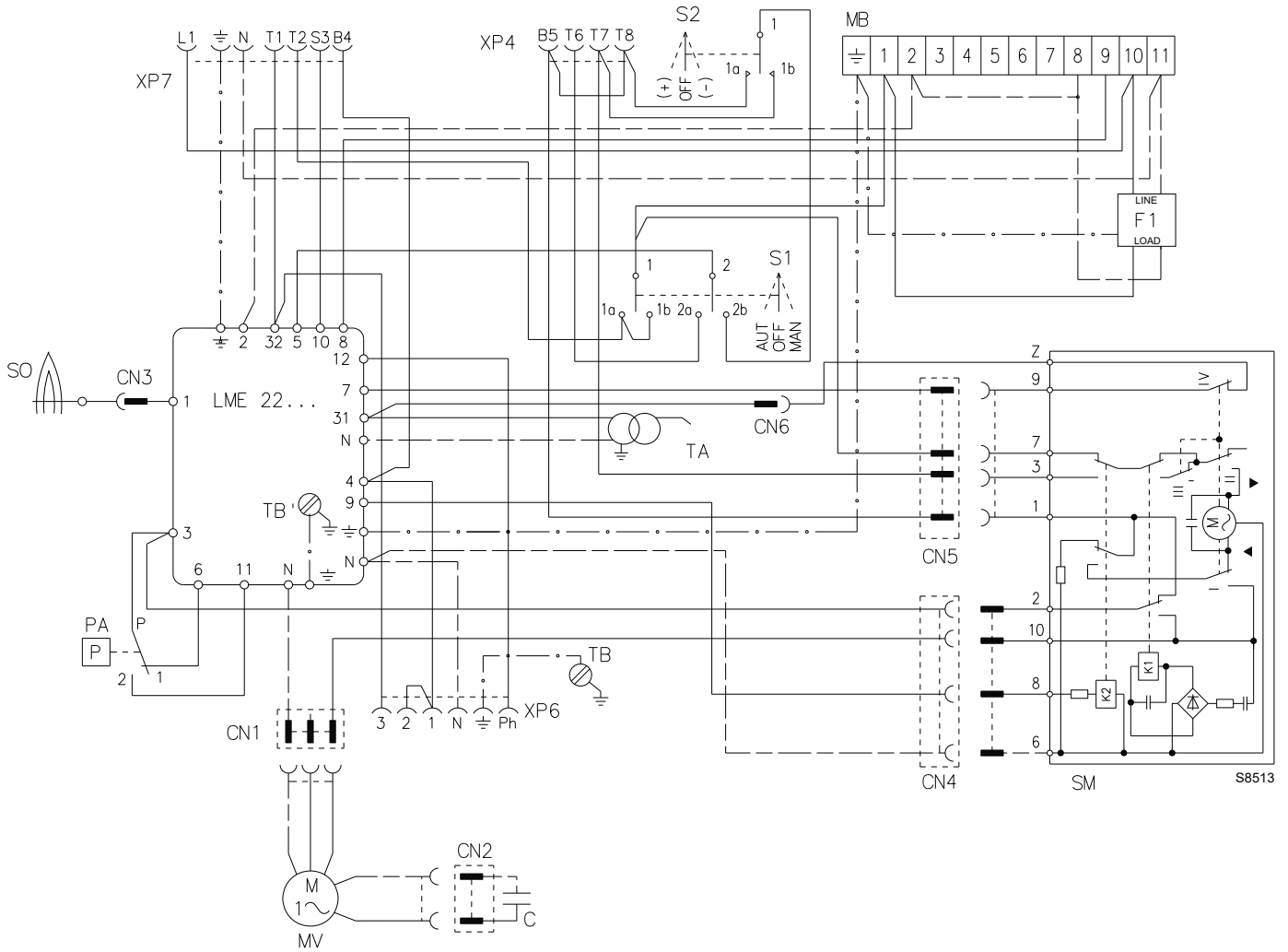

Fig. 17

Key (Fig. 17)

- C Motor capacitor
- CN... Connectors
- F1 Filter to protect against radio disturbance
- MB Auxiliary terminal board
- MV Motor
- PA Minimum air pressure switch.
- SM Servomotor
- SO Ionisation probe
- S1 Operation switch:
MAN = manual
AUT = automatic
OFF = unlit
- S2 Button for:
- = decreasing output
+ = increasing output
- TA Ignition transformer
- TB Burner earth
- XP4 4-pole socket
- XP6 6- pole socket
- XP7 7-pole socket

5.10.2 Electrical wiring to be carried out by the installer

WITHOUT OUTPUT POWER REGULATOR (progressive two-stage operation)

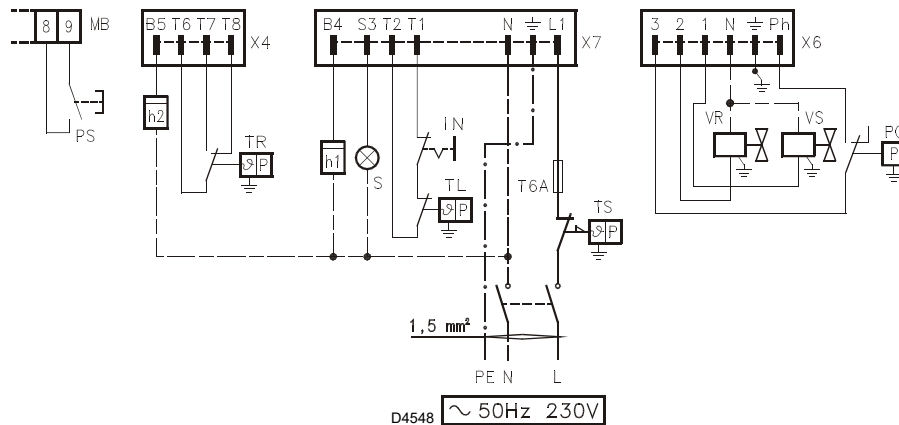

Fig. 18



WARNING

If the boiler is fitted with a 7-pin plug, it has to be replaced with the one supplied with the burner.

Key (Fig. 18)

- PS Remote manual reset
- MB Burner terminal strip
- X7 7-pin plug
- X4 4-pin plug
- X6 6-pin plug
- h2 2nd stage hour counter

- TR High/low flame thermostat
- h1 1st stage hour counter
- S Remote lockout signal
- IN Manual switch
- TL Limit thermostat
- T6A Fuse
- TS Safety thermostat
- PG Min gas pressure switch
- VR Adjustment solenoid
- VS Safety solenoid

WITH OUTPUT POWER REGULATOR (modulating operation)

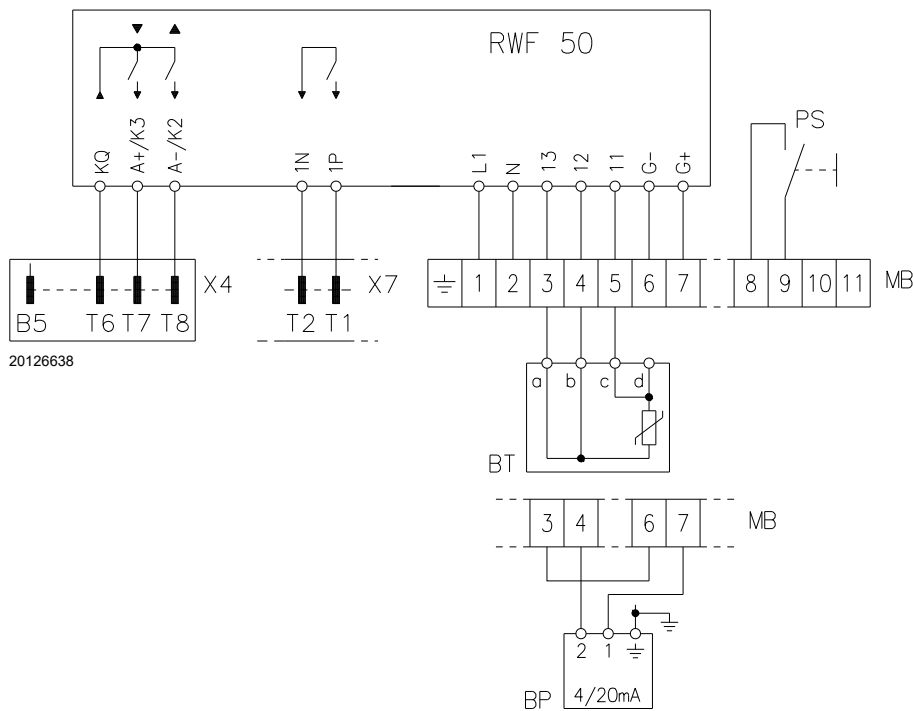

Fig. 19



WARNING

Do not connect any contact between T6 and T8 of the 4-pin plug and between T1 and T2 of the 7-pin plug in order to avoid interference with the regulator.

Key (Fig. 19)

- PS Remote manual reset
- MB Burner terminal strip
- X4 4-pin plug
- X7 7 pin plug
- BT Temperature probe
- BP Pressure probe

6 Start-up, calibration and operation of the burner

6.1 Notes on safety for the first start-up



The first start-up of the burner must be carried out by qualified personnel, as indicated in this manual and in compliance with the standards and regulations of the laws in force.



Check the correct working of the adjustment, command and safety devices.



Refer to paragraph “Safety test - with gas ball valve closed” on page 28 before the first start-up.

6.2 Adjustments prior to ignition

- Check the adjustment of the head as shown in page 17.
- Check the adjustment of the air damper servomotor as shown in page 25.
- Slowly open the manual valves situated upstream from the gas train.
- Adjust the air pressure switch (Fig. 24) to the start of the scale.

- Purge the air from the gas line. We recommend using a plastic tube routed outside the building and to purge air until gas is smelt.



Before starting up the burner, it is good practice to adjust the gas train so that ignition takes place in conditions of maximum safety, i.e. with gas delivery at the minimum.

6.3 First ignition

After checking the electrical wiring and the seal of the hydraulic connections, set the air pressure switch at the minimum value.

Connect the pressure gauge to the gas pressure test point of the burner M3)(Fig. 14 on page 19).

The Tab. M indicates the ignition settings for a burner operating with methane gas.

The reference values are:

- the ignition output;
- the pre-calibration position of the air damper (CAM III);
- the pre-calibration position of the calibration screw of the POINT 0 of the gas train;
- the gas train model to use.

Burner	Ignition output	Adjusting CAM III	Adjusting POINT 0	Adjusting gas/air ratio	Gas train
	kW	Notch No.	Notch No.	Notch No.	Model
BS1/M	16 ÷ 52	20° ÷ 30°	◆	Depending on the maximum output	CG 120
BS2/M	26 ÷ 33	20° ÷ 30°	◆		CG 220
BS3/M	48 ÷ 83	30° ÷ 40°	◆		
BS4/M	68 ÷ 110	30° ÷ 35°	◆		

Tab. M

- ◆ Set to values near the start of the scale (-1.5).
- 1 Depending on the maximum output required, adjust the combustion head as indicated on page 17.
- 2 Select the “MAN” operating mode (Fig. 20) and carry out the calibration of CAM III of the servomotor and the calibration screw of the POINT 0 as indicated in Tab. M, then start the burner.
- 3 After igniting, manually bring the servomotor to the second flame position by pressing the “+” switch (Fig. 20). During this operation check the stability of the flame: if it is unstable, slowly increase or decrease the setting of the gas/air ratio calibration screw until the desired maximum output and the correct CO₂ values in the flue gases are attained, then calibrate cam I to the value reached by the servomotor.
- 4 Manually bring the servomotor to the first flame position by pressing the “-” switch (Fig. 20). Check the combustion and if necessary use just the screw for calibrating the POINT 0 to obtain the correct CO₂ values in the flue gases.

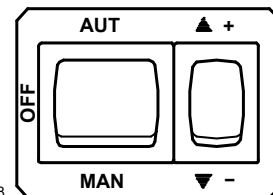

D4468

Fig. 20

- 5 If the first flame output needs modifying, use CAM III. All the changes to the POINT 0 calibration screw will also change the maximum gas output.
- 6 Once again bring the servomotor to the maximum opening and check the maximum output again, using the screw for calibrating the gas/air ratio.
- 7 Turn the servomotor again to the first flame position and adjust the output again, just using the POINT 0 calibration screw.

- 8 Repeat operations 6) and 7) until no more adjustments of the gas/air ration calibration and the POINT 0 screws are needed.
- 9 Check the combustion values at an intermediate output and if necessary proceed with further adjustments of the gas/air calibration and the POINT 0 screws. When finished, after checking that the burner has a good ignition and good flame stability, select automatic operating by putting the selector switch to "AUT" (Fig. 20): the modulation will occur between the calibration position of CAM II and that of CAM I.

6.4 Air damper servomotor adjustment

STOP CAM II

CAM II makes sure the air damper closes when the burner has stopped. It is factory set at 0°.



WARNING

Do not change!

FIRST STAGE CAM III

CAM III adjusts the position of the air damper when the burner is at minimum output. This can be adjusted during commissioning. **CAM IV** is joined solidly to **CAM III**.

SECOND STAGE CAM I

CAM I adjusts the position of the air damper when the burner is working at maximum output and should be used to limit the output of the burner (adaptation to the output of the boiler). It is factory set at 90°.

The servomotor follows the adjustment of **CAM III** only when the cam angle is reduced.

If the cam angle needs to be increased, it is first necessary to increase the angle of the servomotor with the key "increase output" +)(Fig. 20), then increase the angle of **CAM III** and finally bring the servomotor to the MIN output position with the key "decrease output" -(Fig. 20).

For any adjustment to **CAM III**, remove the cover 1)(Fig. 21), snap fitted, remove the relative key 2) from inside and insert it into the notch of **CAM III**.

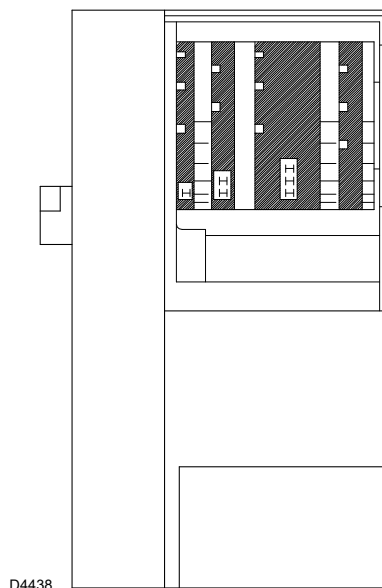

Fig. 21

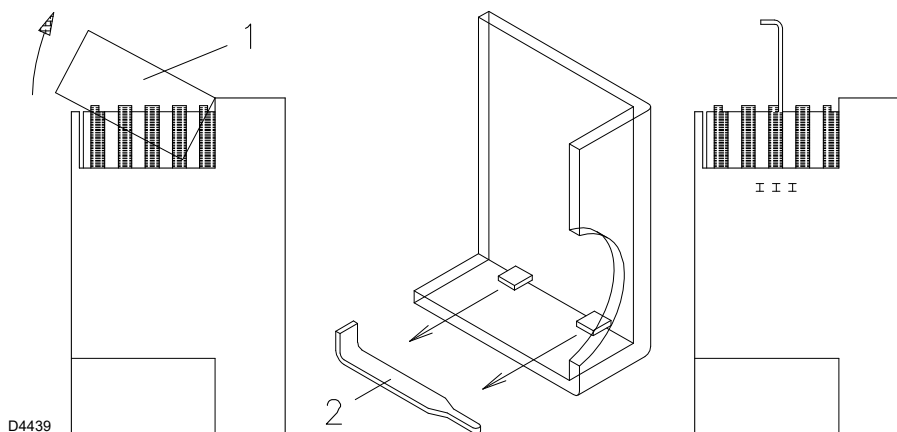

Fig. 22

NOTE:
the cam shaft has two pointers for indicating the direction of rotation.



WARNING

For the SQN91 servomotor, only the single indicator (on the right in Fig. 23) must be used.



Fig. 23

6.5 Gas pressure switch



To calibrate the gas pressure switch, refer to the gas train manual.

6.6 Air pressure switch

Adjust the air pressure switch after performing all other burner adjustments with the air pressure switch (Fig. 24) set to the start of the scale.

With the burner operating at maximum output, turn the knob slowly in a clockwise direction until burner lockout.

Then turn the knob anticlockwise to an extent that is around 20% of the adjusted value and then check that the burner starts up properly.

If the burner locks out again turn the knob slightly in an anticlockwise direction.

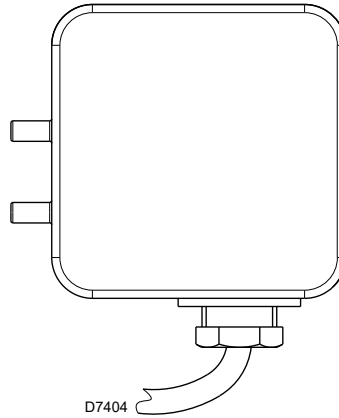

Fig. 24



In conformity with the standard, the air pressure switch must prevent the air pressure falling below 80% of the adjusted value and the CO in the flue gases exceeding 1% (10,000 ppm).

To check this, insert a combustion analyser in the flue, slowly reduce the burner air setting (for example with a piece of cardboard) and verify that the burner locks out before the CO value in the flue gases exceeds 1%.

6.7 Combustion adjustment

In conformity with EN 676 the application of the burner on the boiler, adjustment and testing must be carried out observing the instruction manual of the boiler, including verification of the CO and CO₂ concentration in the flue gases, their temperatures and the average temperature of the water in the boiler.

It is advisable to set the burner according to the type of gas used and following the indications in Tab. N.

EN 676		Air excess: max. output. $\lambda \leq 1.2$ – min. output $\lambda \leq 1.3$			
GAS	Theoretical max CO ₂ 0 % O ₂	Setting CO ₂ %		CO mg/kWh	NO _x mg/kWh
		$\lambda = 1.2$	$\lambda = 1.3$		
G 20	11.7	9.7	9.0	≤ 100	≤ 170
G 25	11.5	9.5	8.8	≤ 100	≤ 170
G 30	14.0	11.6	10.7	≤ 100	≤ 230
G 31	13.7	11.4	10.5	≤ 100	≤ 230

Tab. N

6.8 Operation sequence of the burner

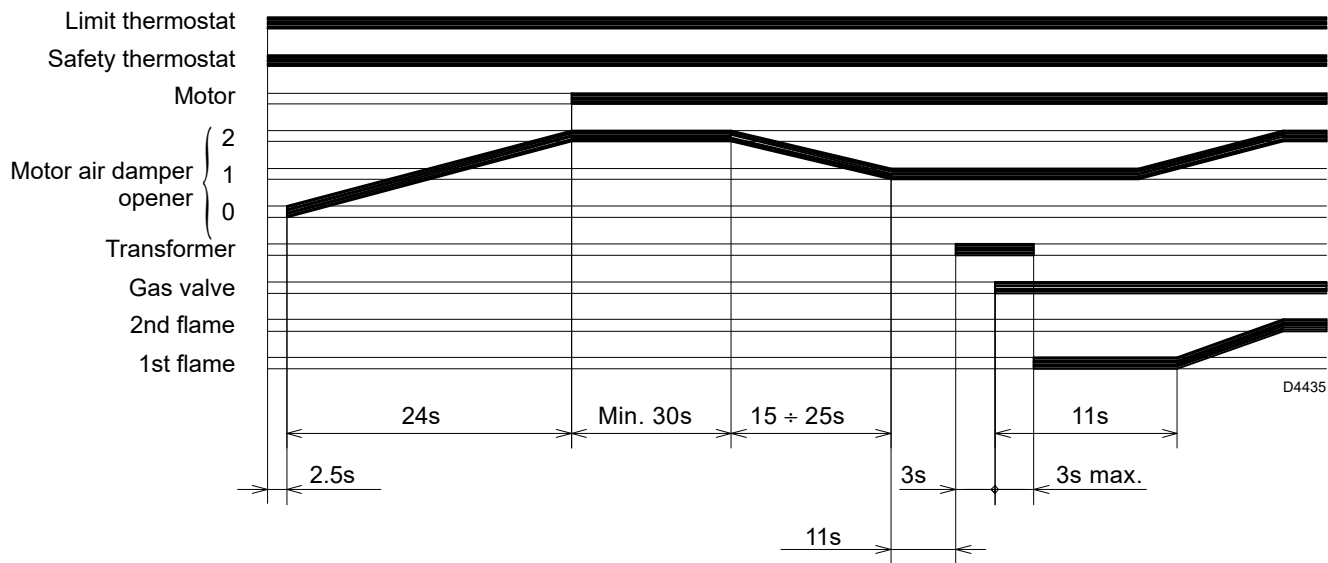

Fig. 25

7 Maintenance

7.1 Notes on safety for the maintenance

The periodic maintenance is essential for the good operation, safety, yield and duration of the burner.

It allows you to reduce consumption and polluting emissions and to keep the product in a reliable state over time.



The maintenance interventions and the calibration of the burner must only be carried out by qualified, authorised personnel, in accordance with the contents of this manual and in compliance with the standards and regulations of current laws.

Before carrying out any maintenance, cleaning or checking operations:



Turn off the burner's power supply using the main system switch.



Turn off the fuel interception tap.



Wait for the components in contact with heat sources to cool down completely.

7.2 Maintenance programme

7.2.1 Maintenance frequency



The gas combustion system should be checked at least once a year by a representative of the manufacturer or another specialised technician.



IF THE ELECTRICAL SUPPLY OF THE GAS VALVES OCCURS AT UNEXPECTED TIMES, DO NOT OPEN MANUAL GAS BALL VALVE, SWITCH OFF POWER LINE; CHECK THE WIRES; CORRECT THE ERRORS AND REPEAT THE COMPLETE TEST.

7.2.2 Safety test - with gas ball valve closed

It is fundamental to ensure the correct execution of the electrical connections between the gas solenoid valves and the burner to perform safely the commissioning.

For this purpose, after checking that the connections have been carried out in accordance with the burner's electrical diagrams, an ignition cycle with closed gas ball valve -dry test- must be performed

- 1 The manual ball gas valve must be closed
- 2 The electrical contacts of the burner limit switch need to be closed
- 3 Ensures closed the contact of the low gas pressure switch
- 4 Make a trial for burner ignition.

The start-up cycle must be as follows:

- Starting the fan for pre-ventilation
- Performing the gas valve seal control, if provided
- Completion of pre-ventilation
- Arrival of the ignition point
- Power supply of the ignition transformer
- Electrical Supply of solenoid gas valves.

Since the manual gas ball valve is closed, the burner will not light up and its flame control will go to a safety lockout condition.

The actual electrical supply of the solenoid gas valves can be verified by inserting a tester. Some valves are equipped with light signals (or close/open position indicator) that turn on at the same time as their power supply.

7.2.3 Checking and cleaning



The operator must use the required equipment during maintenance.

Combustion

Check there are no occlusions or obstructions in the fuel supply or return lines, in the air suction areas, and in the combustion product waste pipe.

Carry out an analysis of the combustion flue gases.

Significant differences with respect to the previous measurements indicate the points where most care should be exercised during maintenance.

Combustion head

Check that the positioning of the combustion head is correct and that it is properly fixed to the boiler.

Open the burner and make sure that all components of the combustion head are in good condition, not deformed by the high temperatures, free of impurities from the surroundings and correctly positioned.

Burner

Check that there are not excess wear or loosen screws. Clean the outside of the burner.

Fan

Check that the air damper is positioned correctly. Check to make sure that no dust has accumulated inside the fan or on its blades, as this condition will cause a reduction in the air flow rate and provoke polluting combustion.

Gas distributor

Check at regular intervals that the holes of the gas head are not obstructed. If they are, clean them with a pointed tool as shown in Fig. 26.

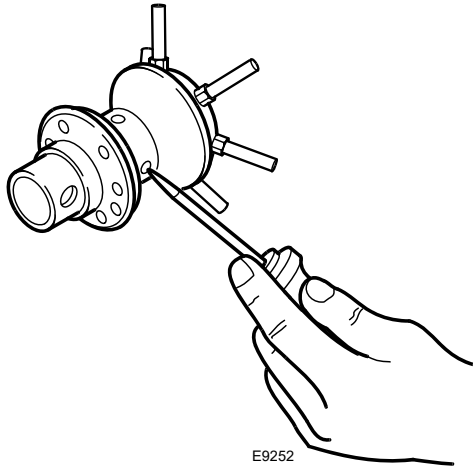

Fig. 26

Boiler

Clean the boiler as indicated in its accompanying instructions in order to maintain all the original combustion characteristics intact, especially the flue gas temperature and combustion chamber pressure.

Gas train

Check that the gas train is suited to the burner capacity, the type of gas used and the mains gas pressure.

Electrode-probe

Checking the proper positioning of the ionisation probe and electrode as shown in Fig. 13 on page 18.

Pressure switches

Check that the air pressure switch and the gas pressure switch are set correctly.

Gas leaks

Make sure that there are no gas leaks on the pipe between the gas meter and the burner.

Gas filter

Change the gas filter when it is dirty.

Combustion

If the combustion values measured before starting maintenance do not comply with applicable legislation or do not indicate efficient combustion, consult the Tab. N on page 26 or contact our Technical Support Service to implement the necessary adjustments.

Leave the burner working without interruption for about 10 min, checking the right settings in the 1st and 2nd stage of all the components stated in this manual

- Percentage of CO₂ (%)
- CO content (ppm)
- NOx content (ppm)
- Ionisation current (µA)
- Smoke temperature at the flue

7.3 Opening the burner

Turn off the burner's power supply using the main system switch.



Turn off the fuel interception tap.



Wait for the components in contact with heat sources to cool down completely.

If maintenance of the combustion head is required, refer to the instructions given in "Operating position" on page 15.

For accessing to the interior of the burner, loosen the screws that secure the cover and proceed with the maintenance operation.

**Operating safety hazards**

Repairs to the following components may only be carried out by the respective manufacturers or by personnel instructed by them:

- fan motor
- actuator
- air damper servomotor
- electromagnetic valves
- burner programmer

Check the operation

- Start-up of the burner with a sequence of functions (see chapter "Operation sequence of the burner" on page 27).
- Ignition device.
- Air pressure switch.
- Flame monitoring.
- Seal test of components to the passage of fuel.



After carrying out maintenance, cleaning or checking operations, reassemble the cover and all the safety and protection devices of the burner.

8 Faults - Possible causes - Solutions

The flame control has a self-diagnostic system, which allows the operating malfunctions to be easily identified.

When the button is released, the RED LED starts to blink, as shown in the following table.

To use this function, wait at least ten seconds from the safety lock out, and then press the reset button for a minimum of 3 seconds.

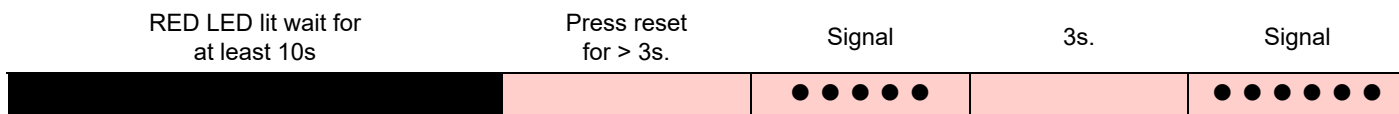

Tab. O

The pulses of the LED constitute a signal spaced by approximately 3 seconds. The number of pulses will provide information about the possible faults, according to the following key.

Signal	Possible Causes
2 ● ●	No stable flame signal is detected within the safety time: – faulty ionisation probe; – faulty gas valve; – phase/neutral connections inverted; – burner not regulated.
3 ● ● ●	Minimum air pressure switch fails to close: – check the intervention of the VPS lockout; – faulty air pressure switch; – air pressure switch not adjusted; – the fan motor is not working; – intervention of maximum air pressure switch.
4 ● ● ● ●	Light present in the chamber during pre-purging, or else flame control faulty.
5 ● ● ● ● ●	Minimum air pressure switch fails to switch: – faulty air pressure switch; – air pressure switch not adjusted.
7 ● ● ● ● ● ● ●	Loss of flame during operation: – burner not regulated; – faulty gas valve; – short-circuit between the ionisation probe and the earth.
10 ● ● ● ● ● ● ● ● ● ●	flame control faulty.

Tab. P

A Appendix - Accessories**Kit for modulating operation**

With the modulating operation, the burner automatically adapts the output delivered between its maximum and minimum values, keeping the parameter, temperature or pressure to be controlled constant.

Two components should be ordered:

- a probe to be installed on the boiler
- an output regulator to be installed on the burner
- a potentiometer (1000 Ω)

Type of probe	Adjustment field	Code
PT 100 temperature	-100...+500°C	3010110
Pressure 4 - 20 mA	0...2.5 bar	3010213
Pressure 4 - 20 mA	0...16 bar	3010214

Regulator	Code	Potentiometer	Code
RWF50.2	20102002	ASZ12.7	3010109
RWF55.5	20101966		

Long head kit

Burner	Standard length (mm)	Long head length (mm)	Code
BS1/M	70 - 116	114 - 160	20097850
BS2/M	100 - 114	170 - 180	3002722
BS2/M	100 - 114	270 - 280	3002723
BS3/M	110 - 128	267 - 282	3002724
BS4/M	145 - 168	302 - 317	3002725

LPG kit

Burner	Code
BS1/M	3001003
BS2/M	3002711
BS3/M	3002712
BS4/M	3001011

7-pin plug kit

Burner	Code
All models	3000945

Gas trains in compliance with EN 676

Please refer to manual.

Vibration-damping flame funnel kit

Burner	Code
BS1/M	3001059
BS2/M	3001064
BS3/M	3001060
BS4/M	3001070

PC interface kit

Burner	Code
All models	3002719

Differential circuit breaker kit

Burner	Code
All models	3001180

RIELLO

RIELLO S.p.A.
I-37045 Legnago (VR)
Tel.: +39.0442.630111
[http:// www.riello.it](http://www.riello.it)
[http:// www.riello.com](http://www.riello.com)