

**GB** **Forced draught gas burners**

Progressive two-stage operation

**CE**

**UK  
CA**

**EAC**

CODE	MODEL	TYPE
3783302	RS 28	809 T1
3783303	RS 28	809 T1
3784402	RS 38	810 T1
3784403	RS 38	810 T1
3784502	RS 38	810 T1
3784503	RS 38	810 T1
3784702	RS 50	811 T1
3784703	RS 50	811 T1



**Translation of the original instructions**

<b>1</b>	<b>Information and general warnings.....</b>	<b>3</b>
1.1	Information about the instruction manual .....	3
1.1.1	Introduction.....	3
1.1.2	General dangers.....	3
1.1.3	Other symbols .....	3
1.1.4	Delivery of the system and the instruction manual .....	4
1.2	Guarantee and responsibility.....	4
<b>2</b>	<b>Safety and prevention.....</b>	<b>5</b>
2.1	Introduction.....	5
2.2	Personnel training .....	5
<b>3</b>	<b>Technical description of the burner .....</b>	<b>6</b>
3.1	Burner designation .....	6
3.2	Models available.....	6
3.3	Burner categories - Countries of destination .....	7
3.4	Technical data .....	7
3.5	Electrical data.....	7
3.6	Maximum dimensions.....	8
3.7	Burner equipment.....	8
3.8	Firing rates .....	9
3.9	Test boiler.....	10
3.9.1	Commercial boilers.....	10
3.10	Burner description .....	11
3.11	Flame control RMG88.....	12
3.12	Servomotor SQM.....	13
<b>4</b>	<b>Installation .....</b>	<b>14</b>
4.1	Notes on safety for the installation .....	14
4.2	Handling .....	14
4.3	Preliminary checks .....	14
4.4	Operating position .....	15
4.5	Preparing the boiler .....	15
4.5.1	Boring the boiler plate .....	15
4.5.2	Blast tube length.....	15
4.5.3	Securing the burner to the boiler .....	15
4.6	Access to head internal part.....	16
4.7	Positioning the probe - electrode.....	16
4.8	Combustion head adjustment.....	17
4.9	Gas supply .....	18
4.9.1	Gas feeding line (Example) - Please refer to the gas train documentation for more information.....	18
4.9.2	Gas train.....	19
4.9.3	Gas train installation.....	19
4.9.4	Gas pressure.....	19
4.10	Electrical connections.....	21
4.11	Thermal relay adjustment (RS 38-50 THREE-PHASE).....	22
<b>5</b>	<b>Start-up, calibration and operation of the burner .....</b>	<b>23</b>
5.1	Notes on safety for the first start-up .....	23
5.2	Adjustments prior to ignition .....	23
5.3	Burner start-up .....	23
5.4	Burner ignition .....	24
5.5	Burner adjustment .....	24
5.5.1	Output upon ignition .....	24
5.5.2	Output in 2nd stage .....	24
5.5.3	Output in 1st stage .....	25
5.5.4	Intermediate outputs.....	25

5.6	Pressure switch adjustment .....	26
5.6.1	Air pressure switch .....	26
5.6.2	Gas minimum pressure switch .....	26
5.6.3	Flame presence check .....	26
5.7	Servomotor adjustment .....	27
5.8	Burner operation .....	28
5.8.1	Burner start-up .....	28
5.8.2	Full-running operation - System equipped with TR remote control .....	28
5.8.3	Ignition failure .....	28
5.9	Burner start-up cycle diagnostics .....	29
5.9.1	Resetting of flame control and diagnostics use .....	29
5.9.2	flame control reset .....	29
5.9.3	Visual diagnostics .....	29
5.9.4	Software diagnostics .....	29
<b>6</b>	<b>Maintenance .....</b>	<b>30</b>
6.1	Notes on safety for the maintenance .....	30
6.2	Maintenance programme .....	30
6.2.1	Maintenance frequency .....	30
6.2.2	Safety test - with no gas supply .....	30
6.2.3	Checking and cleaning .....	30
6.2.4	Combustion control (gas) .....	31
6.2.5	Safety components .....	31
6.3	Opening the burner .....	32
6.4	Closing the burner .....	32
<b>7</b>	<b>Faults - Possible causes - Solutions .....</b>	<b>33</b>

**1 Information and general warnings**

**1.1 Information about the instruction manual**

**1.1.1 Introduction**

The instruction manual supplied with the burner:

- is an integral and essential part of the product and must not be separated from it; it must therefore be kept carefully for any necessary consultation and must accompany the burner even if it is transferred to another owner or user, or to another system. If the manual is lost or damaged, another copy must be requested from the Technical Assistance Centre of the area;
- is designed for use by qualified personnel;
- offers important indications and instructions relating to the installation safety, start-up, use and maintenance of the burner.

**Symbols used in the manual**

In some parts of the manual you will see triangular DANGER signs. Pay great attention to these, as they indicate a situation of potential danger.

**1.1.2 General dangers**

The **dangers** can be of **3 levels**, as indicated below.



Maximum danger level!  
This symbol indicates operations which, if not carried out correctly, cause serious injury, death or long-term health risks.



This symbol indicates operations which, if not carried out correctly, may cause serious injury, death or long-term health risks.



This symbol indicates operations which, if not carried out correctly, may cause damage to the machine and/or injury to people.

**1.1.3 Other symbols**



**DANGER: LIVE COMPONENTS**  
This symbol indicates operations which, if not carried out correctly, lead to electric shocks with lethal consequences.



**DANGER: FLAMMABLE MATERIAL**  
This symbol indicates the presence of flammable materials.



**DANGER: BURNING**  
This symbol indicates the risks of burns due to high temperatures.



**DANGER: CRUSHING OF LIMBS**  
This symbol indicates the presence of moving parts: danger of crushing of limbs.



**WARNING: MOVING PARTS**

This symbol indicates that you must keep limbs away from moving mechanical parts; danger of crushing.



**DANGER: EXPLOSION**

This symbol signals places where an explosive atmosphere may be present. An explosive atmosphere is defined as a mixture - under atmospheric conditions - of air and flammable substances in the form of gases, vapours, mist or dust in which, after ignition has occurred, combustion spreads to the entire unburned mixture.



**PERSONAL PROTECTION EQUIPMENT**

These symbols indicate the equipment that must be worn and kept by the operator for protection against threats against safety and/or health while at work.



**OBLIGATION TO ASSEMBLE THE COVER AND ALL THE SAFETY AND PROTECTION DEVICES**

This symbol signals the obligation to reassemble the cover and all the safety and protection devices of the burner after any maintenance, cleaning or checking operations.



**ENVIRONMENTAL PROTECTION**

This symbol gives indications for the use of the machine with respect for the environment.



**IMPORTANT INFORMATION**

This symbol indicates important information that you must bear in mind.

- This symbol indicates a list.

**Abbreviations used**

Ch.	Chapter
Fig.	Figure
Page	Page
Sec.	Section
Tab.	Table

**1.1.4 Delivery of the system and the instruction manual**

When the system is delivered, it is important that:

- the instruction manual is delivered to the user by the system manufacturer, with the recommendation to keep it in the room where the heat generator is to be installed.
- The instruction manual shows:
  - the serial number of the burner;

.....

- the address and telephone number of the nearest Assistance Centre

.....  
 .....  
 .....

- The system supplier must carefully inform the user about:
  - the use of the system;
  - any further tests that may be required before activating the system;
  - maintenance, and the need to have the system checked at least once a year by a representative of the manufacturer or another specialised technician. To ensure a periodic check, the manufacturer recommends the drawing up of a Maintenance Contract.

**1.2 Guarantee and responsibility**

The manufacturer guarantees its new products from the date of installation, in accordance with the regulations in force and/or the sales contract. At the moment of the first start-up, check that the burner is integral and complete.



**ATTENTION**

Failure to observe the information given in this manual, operating negligence, incorrect installation and carrying out of non authorised modifications will result in the annulment by the manufacturer of the guarantee that it supplies with the burner.

In particular, the rights to the guarantee and the responsibility will no longer be valid, in the event of damage to things or injury to people, if such damage/injury was due to any of the following causes:

- incorrect installation, start-up, use and maintenance of the burner;
- improper, incorrect or unreasonable use of the burner;
- intervention of unqualified personnel;
- carrying out of unauthorised modifications on the equipment;
- use of the burner with safety devices that are faulty, incorrectly applied and/or not working;
- installation of untested supplementary components on the burner;
- powering of the burner with unsuitable fuels;
- faults in the fuel supply system;
- continuation of use of the burner when a fault has occurred;
- repairs and/or overhauls incorrectly carried out;
- modification of the combustion chamber with inserts that prevent the regular development of the structurally established flame;
- insufficient and inappropriate surveillance and care of those burner components most likely to be subject to wear and tear;
- use of non-original components, including spare parts, kits, accessories and optional;
- force majeure.

**The manufacturer furthermore declines any and every responsibility for the failure to observe the contents of this manual.**

**2 Safety and prevention**

**2.1 Introduction**

The burners have been designed and built in compliance with current regulations and directives, applying the known technical rules of safety and envisaging all the potential danger situations. It is necessary, however, to bear in mind that the imprudent and clumsy use of the equipment may lead to situations of death risk for the user or third parties, as well as the damaging of the burner or other items. Inattention, thoughtlessness and excessive confidence often cause accidents; the same applies to tiredness and sleepiness.

It is a good idea to remember the following:

- The burner must only be used as expressly described. Any other use should be considered improper and therefore dangerous.

Specifically:

it can be applied to boilers operating with water, steam, diathermic oil, and to other uses expressly named by the manufacturer;

the type and pressure of the fuel, the voltage and frequency of the electrical power supply, the minimum and maximum deliveries for which the burner has been regulated, the pressurisation of the combustion chamber, the dimensions of the combustion chamber and the ambient temperature must all be within the values indicated in the instruction manual.

- Modification of the burner to alter its performance and destinations is not allowed.
- The burner must be used in exemplary technical safety conditions. Any disturbances that could compromise safety must be quickly eliminated.
- Opening or tampering with the burner components is not allowed, apart from the parts requiring maintenance.
- Only those parts envisaged by the manufacturer can be replaced.



The manufacturer guarantees safety and proper functioning only if all burner components are intact and positioned correctly.

**2.2 Personnel training**

The user is the person, body or company that has acquired the machine and intends to use it for the specific purpose. He is responsible for the machine and for the training of the people working around it.

The user:

- undertakes to entrust the machine exclusively to suitably trained and qualified personnel;
- undertakes to inform his personnel in a suitable way about the application and observance of the safety instructions. With that aim, the user undertakes to ensure that everyone knows the use and safety instructions for his own duties;
- Personnel must observe all the danger and caution indications shown on the machine.
- Personnel must not carry out, on their own initiative, operations or interventions that are not within their province.
- Personnel must inform their superiors of every problem or dangerous situation that may arise.
- The assembly of parts of other makes, or any modifications, can alter the characteristics of the machine and hence compromise operating safety. The manufacturer therefore declines any and every responsibility for any damage that may be caused by the use of non-original parts.

In addition:



- must take all the measures necessary to prevent unauthorised people gaining access to the machine;
- the user must inform the manufacturer if faults or malfunctioning of the accident prevention systems are noticed, along with any presumed danger situation;
- personnel must always use the personal protective equipment envisaged by legislation and follow the indications given in this manual.

### 3 Technical description of the burner

#### 3.1 Burner designation

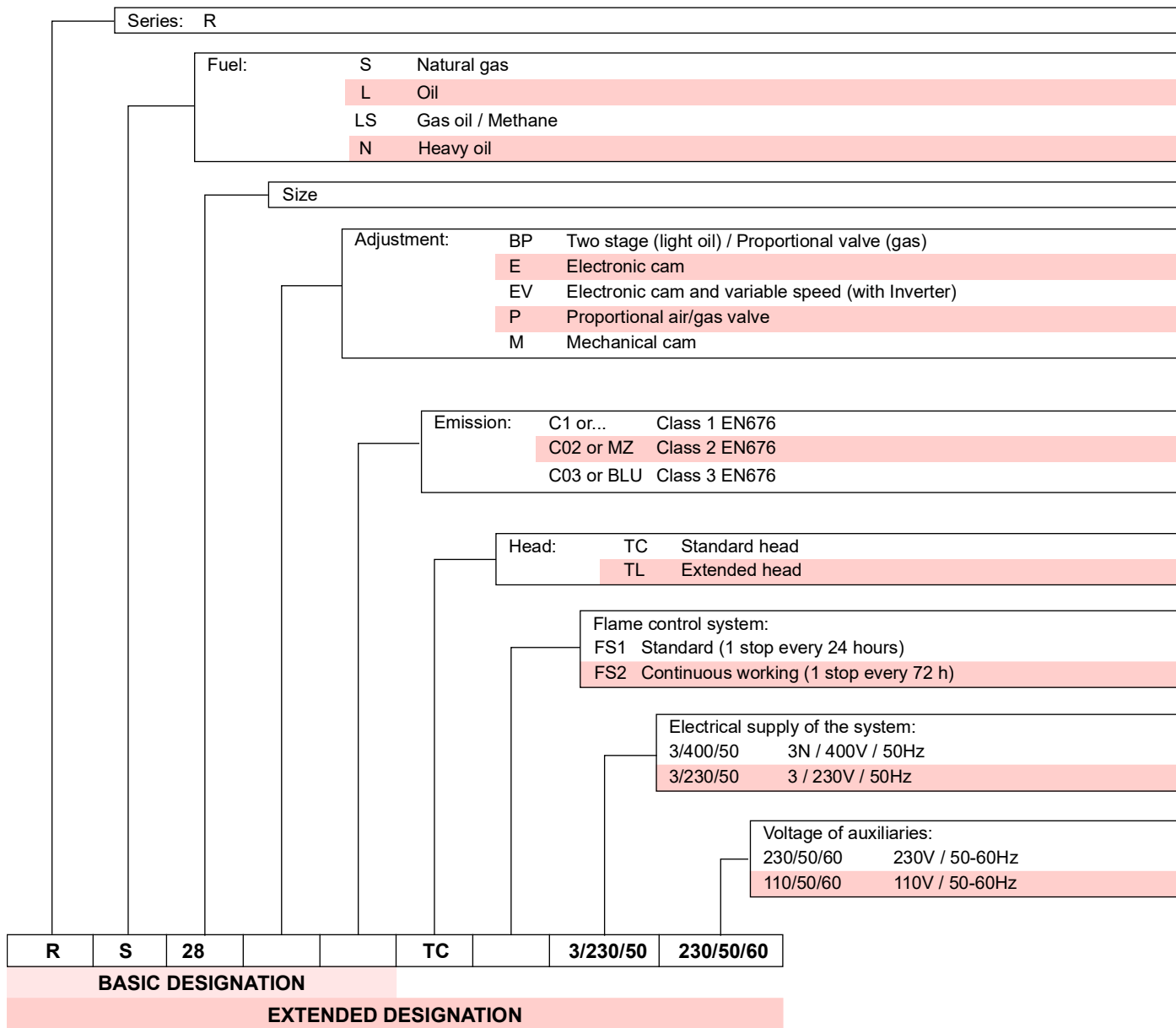

#### 3.2 Models available

Designation		Voltage	Start-up	Code
RS 28	TC	1/230/50	Direct	3783302
RS 28	TL	1/230/50	Direct	3783303
RS 38	TC	1/230/50	Direct	3784402
RS 38	TL	1/230/50	Direct	3784403
RS 38	TC	3/230-400/50	Direct	3784502
RS 38	TL	3/230-400/50	Direct	3784503
RS 50	TC	3/230-400/50	Direct	3784702
RS 50	TL	3/230-400/50	Direct	3784703

**3.3 Burner categories - Countries of destination**

Country of destination	Gas category
SE - FI - AT - GR - DK - ES - GB - IT - IE - PT - IS - CH - NO	I <sub>2H</sub>
DE	I <sub>2ELL</sub>
NL	I <sub>2L</sub> - I <sub>2E</sub> - I <sub>2</sub> (43.46 ÷ 45.3 MJ/m <sup>3</sup> (0°C))
FR	I <sub>2Er</sub>
BE	I <sub>2E(R)B</sub>
LU - PL	I <sub>2E</sub>

**3.4 Technical data**

MODEL			RS 28	RS 38	RS 50
Type			809 T1	810 T1	811 T1
Output <sup>(1)</sup>	2nd stage	kW	163 - 325	232 - 440	295 - 600
		Mcal/h	140 - 280	200 - 378	254 - 516
	1st stage min.	kW	81	105	115
		Mcal/h	70	90	99
Fuel			NATURAL GAS: G20 - G25 - G31		
Operation			<ul style="list-style-type: none"> <li>• Intermittent (min. 1 stop in 24 hours).</li> <li>• Two-stage (high and low flame) and one-stage (all - nothing)</li> </ul>		
Standard use			Boilers: water, steam, diathermic oil		
Ambient temperature		°C	0 - 40		
Combustion air temperature		°C max	60		
Noise Levels <sup>(2)</sup>	Sound Pressure	dB(A)	68	70	72
	Sound Power		79	81	83
CE			CE-0476DP3335		
Weight <sup>(3)</sup>		kg	38 - 40	39 - 41	40 - 42

**Tab. A**

- (1) Reference conditions: Ambient temperature 20°C - Gas temperature 15°C - Barometric pressure 1013 mbar - Altitude 0 m a.s.l.  
 (2) Sound pressure measured in manufacturer's combustion laboratory, with burner operating on test boiler and at maximum output. The sound power is measured with the "Free Field" method, as per EN 15036, and according to an "Accuracy: Category 3" measurement, as described in EN ISO 3746.  
 (3) Blast tube: short-long

**3.5 Electrical data**

Model		RS 28	RS 38	RS 50
Electrical Supply 1 Ph		1N ~ 230 V 50 Hz	1N ~ 230 V 50 Hz	
Electrical Supply 3 Ph		-	3 ~ 230 - 400V ~ +/-10% 50Hz	
Electrical Power Consumption	W max	370	600	750
Protection Level		IP 44		

**Tab. B**

### 3.6 Maximum dimensions

The dimensions of the burner are given in Fig. 1.

Note that to inspect the combustion head the burner must be moved backward and turned upward.

The maximum dimension of the burner, without casing, when open is given by measurement H.

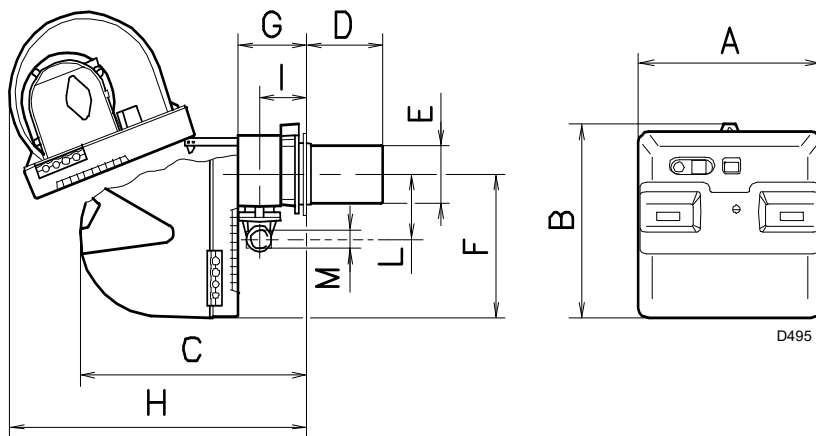

Fig. 1

mm	A	B	C	D <sup>(1)</sup>	E	F	G	H	I	L	M
RS 28	476	474	580	216 - 351	140	352	164	810	108	168	1"1/2
RS 38	476	474	580	216 - 351	140	352	164	810	108	168	1"1/2
RS 50	476	474	580	216 - 351	152	352	164	810	108	168	1"1/2

Tab. C

(1) Blast tube: short-long

### 3.7 Burner equipment

Flange for gas train	No. 1
Seal for flange	No. 1
Flange fixing screws M 8 x 25	No. 4
Thermal flange gasket	No. 1
Screws to fix the burner flange to the boiler: M 8 x 25	No. 4
Cable grommets for the electrical wiring (RS 28 and RS 38 single-phase)	No. 4
Cable grommets for the electrical wiring (RS 38 three-phase and RS 50)	No. 6
Instruction	No. 1
Spare parts list	No. 1



It is recommended to tighten the screws of the gas flange with a tightening torque of **15 Nm ±10%**.

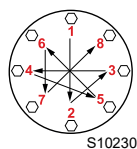

Tighten the nuts gradually (first to 30%, then to 60% up to 100%) according to the cross pattern shown in the figure.

**3.8 Firing rates**

The burners RLS 28- 38 - 50 can work in two ways: one-stage or two-stage.

The **MAXIMUM OUTPUT** is chosen within area A.

The **MINIMUM OUTPUT** must not be lower than the minimum limit of the diagram:

RS 28 = **81 kW**

RS 38 = **105 kW**

RS 50 = **115 kW**



The firing rate value (Fig. 2) has been obtained considering an ambient temperature of 20 °C, an atmospheric pressure of 1013 mbar (approx. 0 m a.s.l.), and with the combustion head adjusted as shown on page 17.

**RS 28**

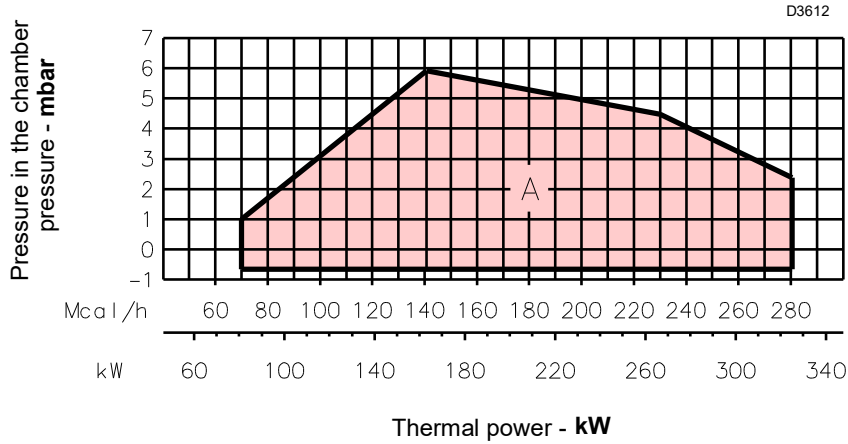

**RS 38**

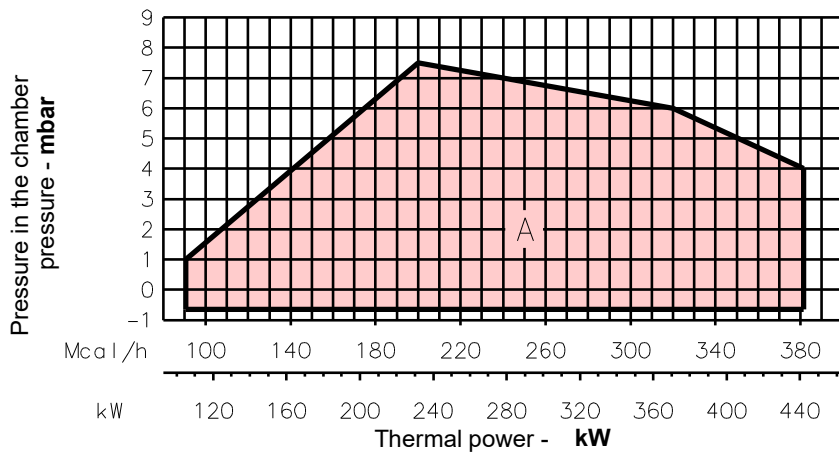

**RS 50**

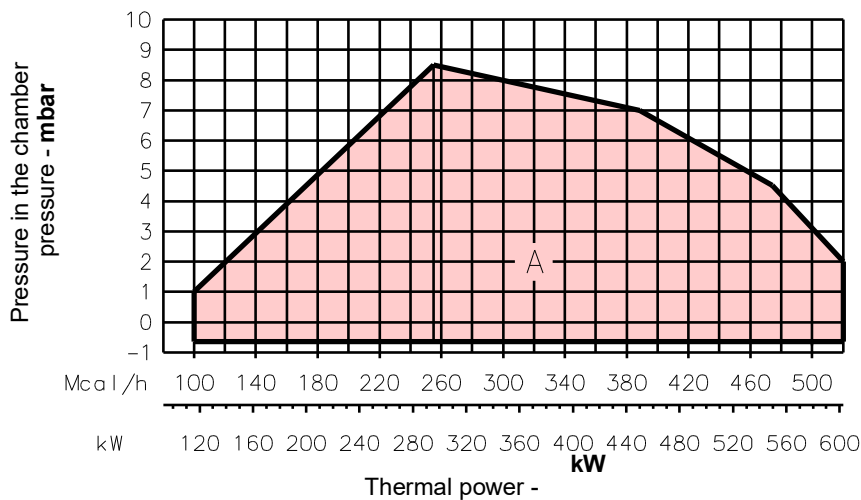

**Fig. 2**

**3.9 Test boiler**

The burner/boiler combination does not pose any problems if the boiler is EC approved and its combustion chamber dimensions are similar to those indicated in the diagram (Fig. 3).

If the burner must be combined with a boiler that has not been EC approved and/or its combustion chamber dimensions are clearly smaller than those indicated in the diagram, consult the manufacturer.

The firing rates were set in relation to special test boilers, according to EN 676 regulations.

In Fig. 3 you can see the diameter and length of the test combustion chamber.

**Example:**

Output 350 kW: diameter 50 cm - length 1.5 m.

**3.9.1 Commercial boilers**

The burner/boiler combination does not pose any problems if the boiler is EC approved and its combustion chamber dimensions are similar to those indicated in the diagram (Fig. 3).

If the burner must be combined with a commercial boiler that has not been EC approved (CE mark) and/or its combustion chamber dimensions are clearly smaller than those indicated in diagram (Fig. 3), consult the manufacturers.

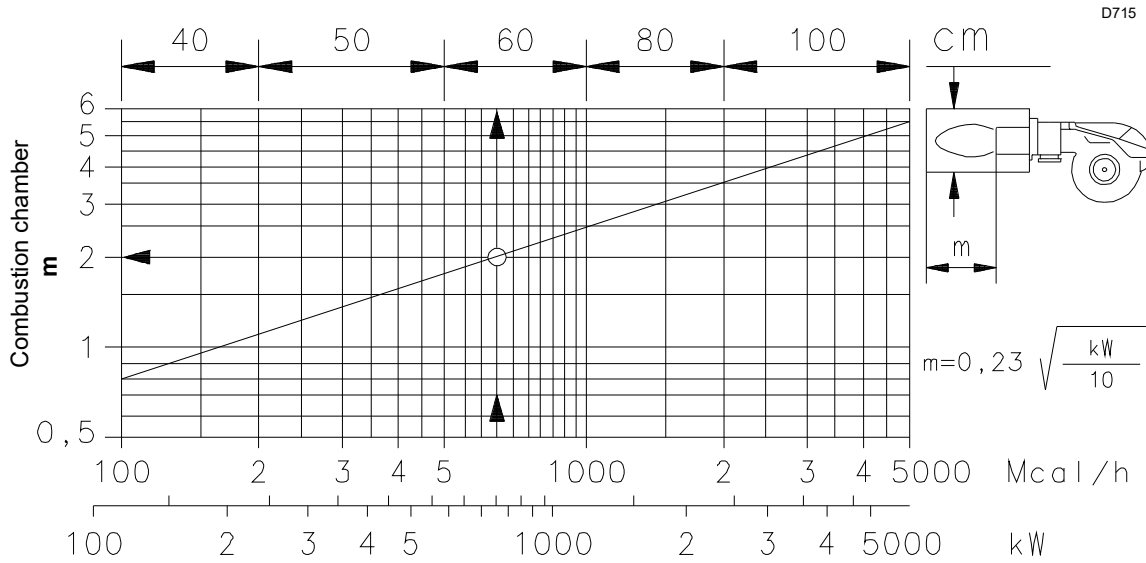

**Fig. 3**

3.10 Burner description

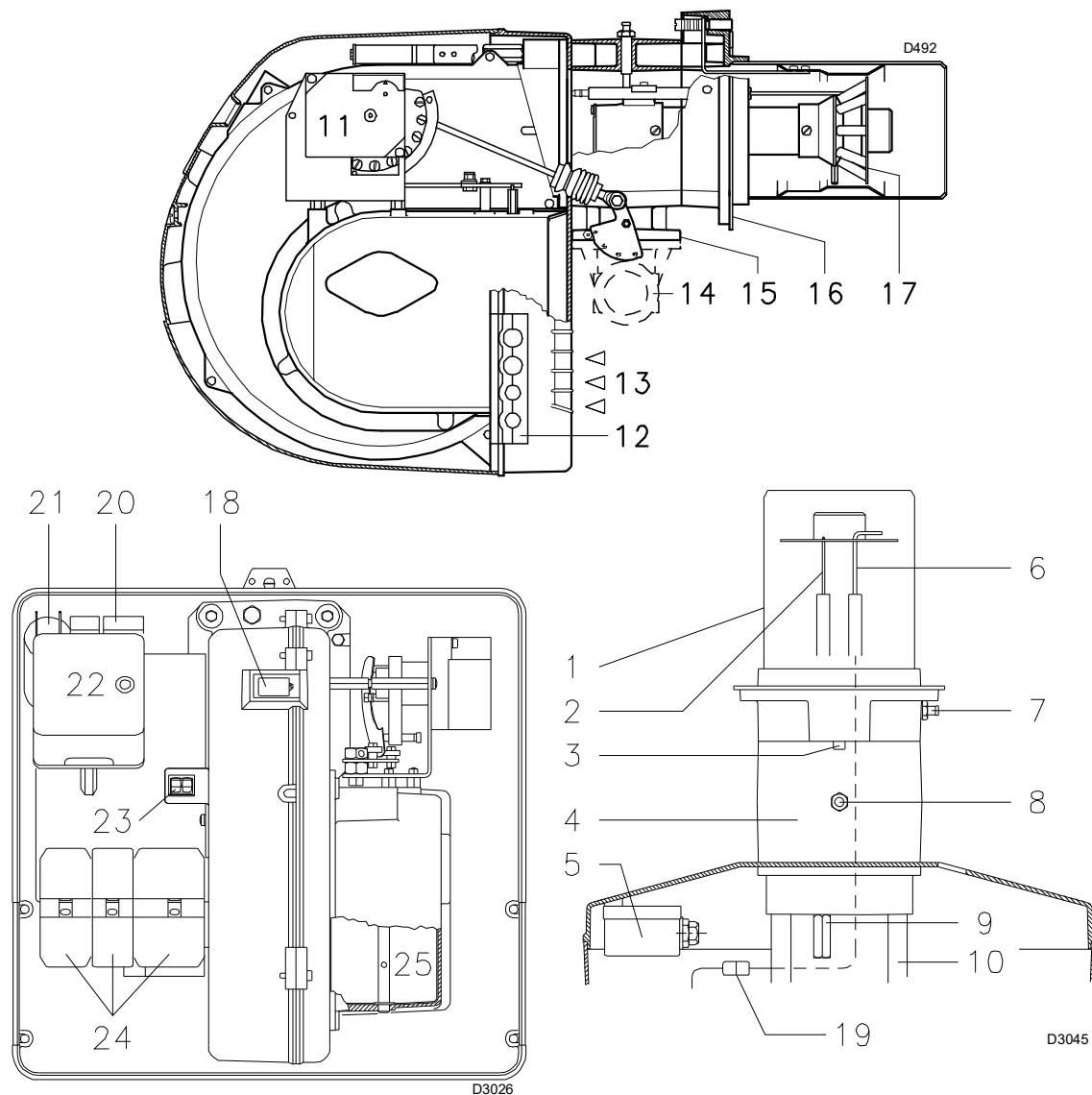

Fig. 4

- 1 Combustion head
- 2 Ignition electrode
- 3 Screw for combustion head adjustment
- 4 Pipe coupling
- 5 Minimum air pressure switch (differential type)
- 6 Flame sensor
- 7 Air pressure test point
- 8 Gas pressure test point and head fixing screw
- 9 Screw securing fan to sleeve
- 10 Slide bars for opening the burner and inspecting the combustion head
- 11 Servomotor controlling the gas butterfly valve and the air damper, by means of a variable profile cam mechanism. When the burner is not operating the air damper is fully closed in order to minimise heat dispersion from the boiler due to the flue draught which draws air from the fan suction inlet.
- 12 Plate with four hole knock-outs for electrical cable routing
- 13 Air inlet to fan
- 14 Gas input pipe
- 15 Gas butterfly valve
- 16 Boiler fixing flange
- 17 Flame stability disc
- 18 Flame inspection window
- 19 Plug-socket on ionisation probe cable
- 20 Motor contactor and thermal relay with reset button (RS 38 three-phase - RS 50)
- 21 Motor capacitor (RS 28 - RS 38 single-phase)
- 22 Flame control with lockout pilot light and reset button
- 23 Two electric switches:
  - one for "burner on - off"
  - one for "1st - 2nd stage"
- 24 Plugs for electrical wiring
- 25 Air damper

Two types of burner lockout may occur:

**FLAME CONTROL LOCKOUT:**

if the flame control button (**red LED**) 22)(Fig. 4) lights up, it indicates that the burner is locked out.  
To reset, hold the pushbutton down for between 1 and 3 seconds.

**MOTOR LOCKOUT (RS 38 three-phase - RS 50):**

Release by pressing the button on thermal relay 20)(Fig. 4).

**3.11 Flame control RMG88...**

**Important notes**



**ATTENTION**

To avoid accidents, material or environmental damage, observe the following instructions!

The flame control RMG88... is a safety device! Avoid opening or modifying it, or forcing its operation. Riello S.p.A. cannot assume any responsibility for damage resulting from unauthorised interventions!

- All interventions (assembly and installation operations, assistance, etc.) must be carried out by qualified personnel.
- Before modifying the wiring in the flame control connection area, fully disconnect the system from the power supply (omnipolar separation). Check the system is not powered and cannot be accidentally reconnected. Failure to do this will lead to the risk of electrocution.
- Protection against electrocution from the flame control and all connected electric components is obtained with the correct assembly.
- Before any intervention (assembly and installation operations, assistance, etc.), ensure the wiring is in order and that the parameters are correctly set, then make the safety checks.
- Falls and collisions can negatively affect the safety functions.  
In this case, the flame control must not be operated, even if it displays no evident damage.
- Press the reset button of the burner lockout command or the reset button (by applying a force of not more than 10 N), without the aid of tools or sharp objects.

For the safety and reliability of the flame control, comply with the following instructions:

- avoid conditions that can favour the development of condensate and humidity. Otherwise, before switching on again, make sure that the entire flame control is perfectly dry!
- Static charges must be avoided since they can damage the flame control's electronic components when touched.



**Fig. 5**

S8906

**Technical data**

Mains voltage	AC 220...240 V +10 % / -15 %
Mains frequency	50 / 60 Hz ± 6%
Power absorption	20 VA
Protection level	IP20
Safety class	I
Weight	approx. 260 g
Cable length	
Thermostat cable	Max. 20 m at 100 pF/m
Air pressure switch	Max. 1 m at 100 pF/m
Gas pressure switch	Max. 20 m at 100 pF/m
Remote reset	Max. 20 m at 100 pF/m
CPI	Max. 1 m at 100 pF/m
Environmental conditions:	
Operation	DIN EN 60721-3-3
Climatic conditions	Class 3K3
Mechanical conditions	Class 3M3
Temperature range	-20...+60°C
Humidity	< 95 % r.h.

**Mechanical structure**

The flame control is made of plastic to resist knocks, heat and flame propagation.

The flame control contains the following components:

- a microprocessor that controls the program sequence, and a relay for controlling the load
- an electronic flame signal amplifier
- a built-in reset button with 3 signalling colours (LED) for status and error messages

**3.12 Servomotor SQM..**

**Important notes**

20143391



To avoid accidents, material or environmental damage, observe the following instructions!

Avoid opening, modifying or forcing the servomotor.

- All interventions (assembly and installation operations, assistance, etc.) must be carried out by qualified personnel.
- Falls and collisions can negatively affect the safety functions. In this case, the servomotor must not be operated, even if it displays no evident damage.
- Fully disconnect the burner from the mains when working near terminals and servomotor connections.
- Condensation and exposure to water are not allowed.
- For safety reasons, the servomotor must be checked after long periods of non-use.

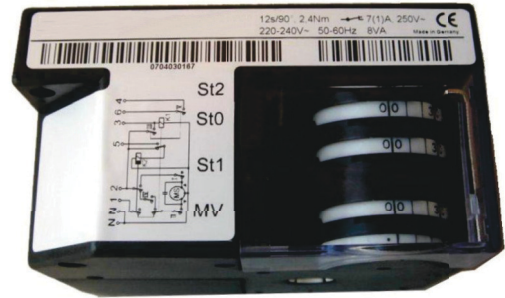

**Fig. 6**

**Technical data**

Mains voltage	220 V -15% +10% ... 240 V + 10%
Mains frequency	50 / 60 Hz +/- 6%
Power absorption	8 VA
Motor	Synchronous
Drive angle	Varying between 0° and 90°
Protection level	IP XX
Cable connection	terminal board for 0.5mm <sup>2</sup> (min.) and 2.5mm <sup>2</sup> (max.)
Rotation direction	Anticlockwise
Rated torque (max.)	2 Nm
Holding torque	1 Nm
Operation time	12 s. at 90°
Weight	approx. 550 kg
Environmental conditions:	
Operation	-20...+60° C
Transport and storage	-20...+60°C



**4.4 Operating position**



- The burner is set up to operate only in positions 1, 2, 3 and 4 (Fig. 8).
- Installation 1 is preferable, as it is the only one that allows the maintenance operations as described in this manual.
- Installations 2, 3 and 4 permit operation but make maintenance and inspection of the combustion head more difficult.



- Any other position could compromise the correct operation of the appliance.
- Installation 5 are forbidden for safety reasons.

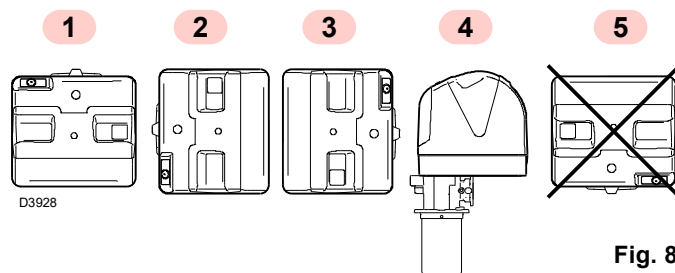

**Fig. 8**

**4.5 Preparing the boiler**

**4.5.1 Boring the boiler plate**

Pierce the closing plate of the combustion chamber, as in Fig. 9. The position of the threaded holes can be marked using the thermal insulation screen supplied with the burner.

mm	A	B	C
RS 28	160	224	M 8
RS 38	160	224	M 8
RS 50	160	224	M 8

**Tab. D**

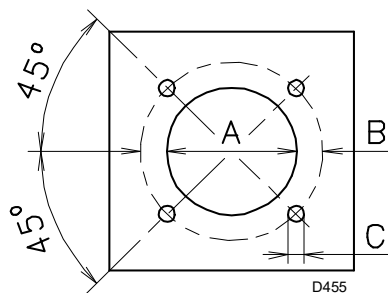

**Fig. 9**

**4.5.2 Blast tube length**

The length of the blast tube must be selected according to the indications provided by the manufacturer of the boiler, and in any case it must be greater than the thickness of the boiler door complete with its fettling. The range of lengths available, L (mm), is as follows:

mm	RS 28	RS 38	RS 50
Standard	216	216	216
Elongated	351	351	351

**Tab. E**

For boilers with front flue passes 15) or flame inversion chamber, a protection in refractory material 13) must be inserted between the boiler fettling 14) and the blast tube 12).

This protective fettling must not compromise the extraction of the blast tube.

**4.5.3 Securing the burner to the boiler**



Provide an adequate lifting system.

Separate the combustion head from the rest of the burner (Fig. 10):

- remove screw 14) and extract cover 15).
- Disengage the articulated coupling 4) from the graduated sector 5)
- Remove the screws 2) from the two slide bars 3).
- Remove the screw 1) and draw the burner back on the slide bars 3) by about 100mm.
- Disconnect the probe and electrode cables and then slide the burner completely out of the slide bars, after removing the split pin from the slide bar 3).

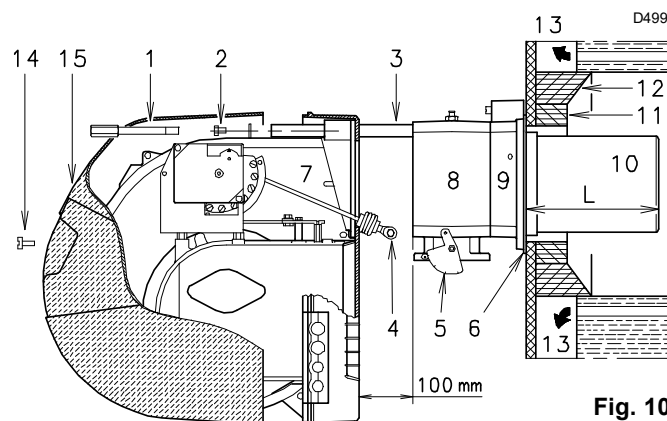

**Fig. 10**



The seal between burner and boiler must be airtight.

### 4.6 Access to head internal part

In order to reach inside the combustion head (Fig. 11) proceed as follows:

- remove the screw 1) and the internal part 2).

Fix the flange 9)(Fig. 10 on page 15) to the plate of the boiler interposing the insulating flange gasket 6)(Fig. 10 on page 15) supplied with the unit. Use the 4 screws, also supplied with the unit, after first protecting the thread with an anti-locking product.

The seal between burner and boiler must be airtight.

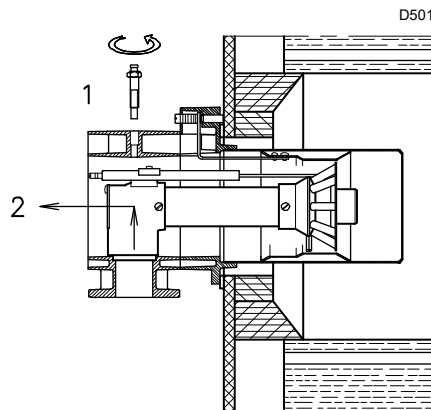

Fig. 11

### 4.7 Positioning the probe - electrode



ATTENTION

Before securing the burner to the boiler, check (through the opening of the blast tube) that the probe and electrode are correctly positioned, as in Fig. 12.

If in the previous check the position of the probe or electrode was not correct, remove the screw 1)(Fig. 11) extract the inner part 2)(Fig. 11) of the head, and adjust them.



ATTENTION

Do not rotate the probe but leave it as in Fig. 12; if it is too close to the ignition electrode, it could damage the flame control amplifier.



ATTENTION

Respect the dimensions shown in Fig. 12.

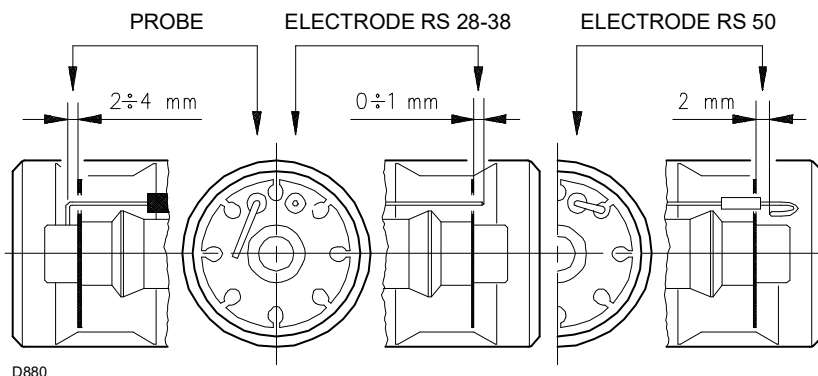

Fig. 12

**4.8 Combustion head adjustment**

At this point of the installation, the combustion head is fixed to the boiler as shown in Fig. 11 on page 16.

It is therefore especially easy to adjust, and this adjustment depends only on the maximum output of the burner.

2 combustion head adjustments are available:

- air
- gas

In the diagram of Fig. 14, find the notch at which both air and central gas/air should be adjusted.

**Air adjustment**

- Turn the screw 4)(Fig. 13) until the notch found lines up with the front surface 5) of the flange.



To facilitate the adjustment, loosen the screw 6)(Fig. 13), adjust, then block.

**Gas adjustment**

- Loosen the screws 1)(Fig. 13) and rotate the ring nut 2) until the notch you have found corresponds with the indicator 3).
- Block the 3 screws 4).

**Example:**

RS 38 burner output = 337 kW (290 Mcal/h).

The diagram (Fig. 14) shows that the gas and air adjustments for this output are carried out on notch 3.

**NOTE:**

The diagram indicates the optimum adjustment for a type of boiler according to Fig. 3 on page 10.



The adjustments indicated can be modified during the initial start-up.

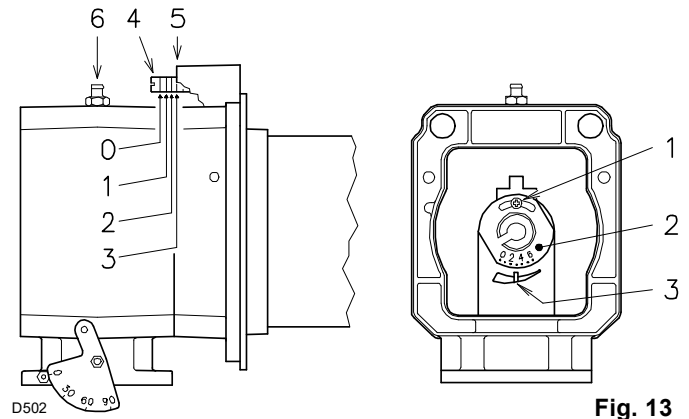

**Fig. 13**

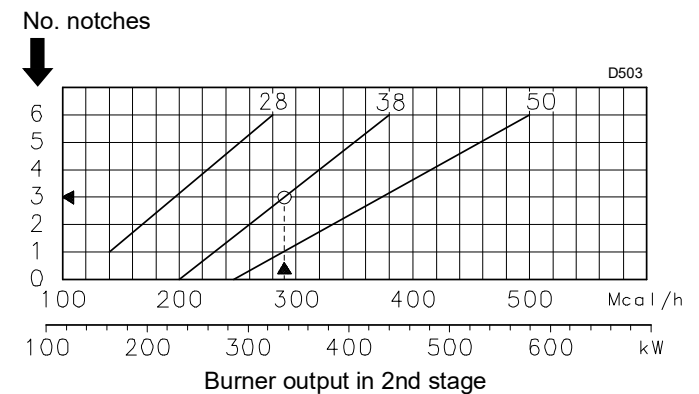

**Fig. 14**

**4.9 Gas supply**



Explosion danger due to fuel leaks in the presence of a flammable source.

Precautions: avoid knocking, attrition, sparks and heat.

Make sure the fuel shut-off valve is closed before performing any operation on the burner.



**ATTENTION**

The fuel supply line must be installed by qualified personnel, in compliance with current standards and laws.

**4.9.1 Gas feeding line (Example) - Please refer to the gas train documentation for more information**

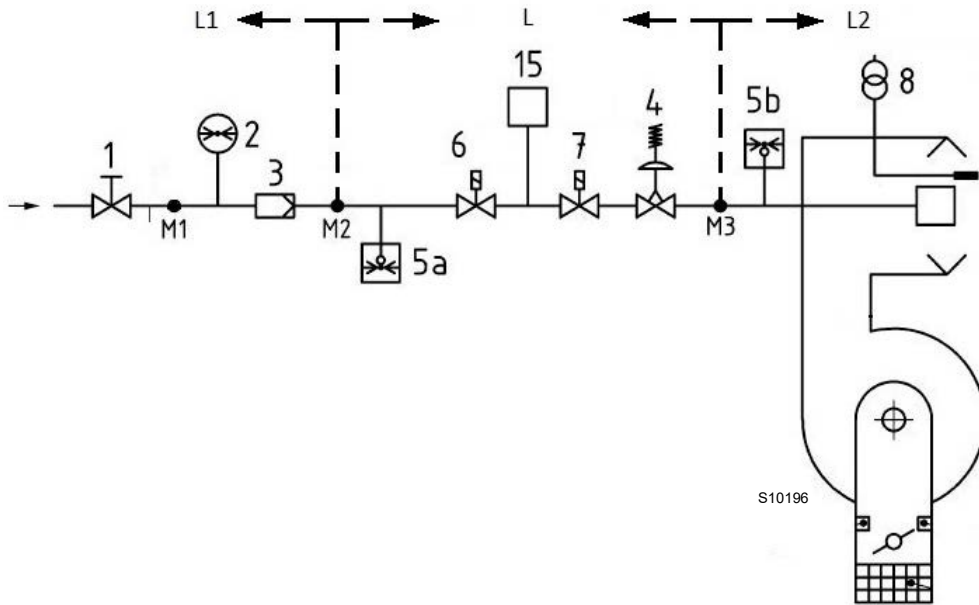

**Fig. 15**

Key (Fig. 15)

- 1 Manually operated shut-off valve
- 2 Pressure gauge
- 3 Filter
- 4 Governor
- 5a Low pressure protection device
- 5b Maximum gas pressure switch
- 6 1st safety shut-off device
- 7 2nd safety shut-off device
- 8 Ignition device
- 15 Valve leak detection control system
- L Gas train (supplied separately)
- L1 Responsibility of the installer
- L2 Burner
- M1 Pressure test point
- M2 Pressure test point
- M3 Pressure test point

**4.9.2 Gas train**

Type-approved in accordance with EN 676 and supplied separately from the burner.

**4.9.3 Gas train installation**



Disconnect the electrical power using the main switch.



Check that there are no gas leaks.



Pay attention when handling the train: danger of crushing of limbs.



Make sure that the gas train is properly installed by checking for any fuel leaks.



The operator must use the required equipment during installation.

The gas train must be connected to the gas connection 1)(Fig. 16), using the flange 2), the gasket 3) and the screws 4) supplied with the burner.

The train can enter the burner from the right or left side, depending on which is the most convenient, see Fig. 16.

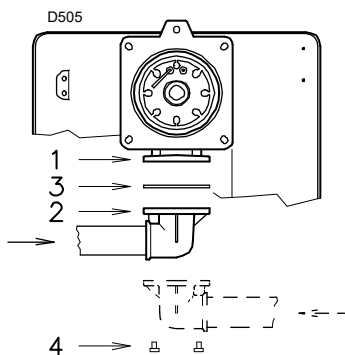

Fig. 16

**4.9.4 Gas pressure**

Tab. F indicates the pressure drops of the combustion head and gas butterfly valve, on the basis of the burner operating output.

Model	kW	1 Δp (mbar)	
		G20	G25
RS 28	165	2.6	3.6
	183	3.2	4.5
	201	3.8	5.3
	218	4.3	6
	236	4.9	6.9
	254	5.5	7.7
	272	6.1	8.5
	289	6.6	9.2
	307	7.2	10.1
	325	7.8	10.9
RS 38	230	2.8	3.9
	253	3.2	4.5
	277	3.7	5.2
	300	4.2	5.9
	323	4.6	6.4
	347	5.1	7.1
	370	5.6	7.8
	393	6.1	8.5
	417	6.7	9.4
	440	7.2	10.1
RS 50	290	2.5	3.5
	322	3.1	4.3
	354	3.8	5.3
	387	4.4	6.2
	419	5.1	7.1
	451	5.7	8
	483	6.4	9
	516	7.1	9.9
	548	7.7	10.8
	580	8.4	11.8

Tab. F



Data of head thermal power and gas pressure refer to operation with gas butterfly valve fully open (90°).

The values shown in Tab. F refer to:

- Natural gas G 20 NCV 10 kWh/Sm<sup>3</sup> (8.6 Mcal/Sm<sup>3</sup>)
- Natural gas G 25 NCV 8.6 kWh/Sm<sup>3</sup> (7.4 Mcal/Sm<sup>3</sup>)

Column 1

Combustion head pressure drop.

Gas pressure measured at test point 1)(Fig. 17), with:

- combustion chamber at 0 mbar;
- burner working at maximum output

Column 2

Pressure loss at gas butterfly valve 2)(Fig. 17) with maximum opening: 90°.

Column 3

Train pressure drop 3)(Fig. 17) including: adjustment valve VR, safety valve VS (both fully open), pressure adjuster R, filter F.

To calculate the approximate output at which the burner operates in the 2nd stage:

- subtract the combustion chamber pressure from the gas pressure measured at test point 1)(Fig. 17).
- Find in Tab. F related to the burner concerned, the pressure value closest to the result of the subtraction.
- Read the corresponding output on the left.

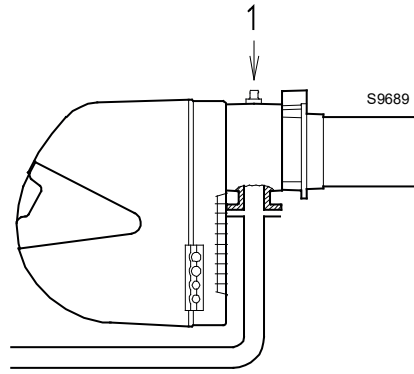

**Fig. 17**

**Example - RS 28:**

2nd stage operation

Natural gas G 20 NCV 10 kWh/Nm<sup>3</sup>

Gas ring nut 2)(Fig. 13 on page 17) adjusted as per diagram (Fig. 14 on page 17).

Gas pressure at test point 1)(Fig. 17)	=	8.6 mbar
Pressure in combustion chamber	=	2.0 mbar
8.6 - 2.0	=	6.6 mbar

A pressure of 6.6 mbar, column 1, corresponds in table RS 28 to a 2nd stage output of 289 kW.

This value serves as a rough guide; the effective output must be measured at the gas meter.

To calculate the required gas pressure at test point 1)(Fig. 17), set the maximum modulating output required from the burner operation:

- find the nearest output value in the table Tab. F for the burner in question.
- read, on the right (column 1), the pressure at the test point 1)(Fig. 17).
- Add this value to the estimated pressure in combustion chamber.

**Example - RS 28:**

Desired output in 2nd stage: 218 kW

Natural gas G 20 NCV 10 kWh/Nm<sup>3</sup>

Gas ring nut 2)(Fig. 13 on page 17) adjusted as per diagram (Fig. 14 on page 17).

Gas pressure at an output of 218 kW	=	4.3 mbar
Pressure in combustion chamber	=	2.0 mbar
4.3 + 2.0	=	6.3 mbar

pressure required at test point 1)(Fig. 17).

**4.10 Electrical connections**

**Notes on safety for the electrical wiring**



- The electrical wiring must be carried out with the electrical supply disconnected.
- Electrical wiring must be made in accordance with the regulations currently in force in the country of destination and by qualified personnel. Refer to the wiring diagrams.
- The manufacturer declines all responsibility for modifications or connections different from those shown in the wiring diagrams.
- Check that the electrical supply of the burner corresponds to that shown on the identification label and in this manual.
- The burner has been type-approved for intermittent use. This means they should compulsorily be stopped at least once every 24 hours to enable the flame control to perform checks of its own start-up efficiency. Normally, burner stopping is guaranteed by the boiler's thermostat/pressure switch.
- If this is not the case, a time switch should be fitted in series to TL to stop the burner at least once every 24 hours. Refer to the wiring diagrams.
- The electrical safety of the device is obtained only when it is correctly connected to an efficient earthing system, made according to current standards. It is necessary to check this fundamental safety requirement. In the event of doubt, have the electrical system checked by qualified personnel. Do not use the gas tubes as an earthing system for electrical devices.
- The electrical system must be suitable for the maximum power absorption of the device, as indicated on the label and in the manual, checking in particular that the section of the cables is suitable for that level of power absorption.
- For the main power supply of the device from the electricity mains:
  - do not use adapters, multiple sockets or extensions;
  - use a multiple pole switch with at least a 3 mm gap between the contacts (overvoltage category III), as envisaged by the present safety standards.
- Do not touch the device with wet or damp body parts and/or in bare feet.
- Do not pull the electric cables.

Before carrying out any maintenance, cleaning or checking operations:



Disconnect the electrical supply from the burner by means of the main system switch.



Close the fuel shut-off valve.



Avoid condensate, ice and water leaks from forming.

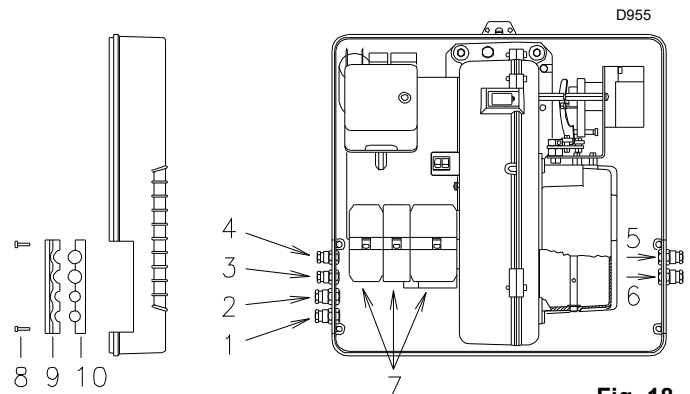

**Fig. 18**

Use flexible cables according to EN 60 335-1 Regulations:

- if in PVC sheath, use at least H05 VV-F
- if in rubber sheath, use at least H05 RR-F.

All the cables to be connected to the plugs 7)(Fig. 18) of the burner are passed through cable grommets supplied with the unit to be inserted in the holes of the plate, left or right, after having unscrewed the screws 8), opened the plate at parts 9 and 10 and removed the thin diaphragm that closes the holes.

The use of the cable grommets and the pre-blanked holes can be done in different manners; for example:

**RS 28 and RS 38 single-phase**

- |   |       |  |
|---|-------|--|
| 1 | Pg 11 | Single-phase power supply                                  |
| 2 | Pg 11 | Gas valves   |
| 3 | Pg 9  | TL remote control  |
| 4 | Pg 9  | TR remote control  |
| 5 | Pg 11 | Gas pressure switch or valve leak detection control device |

**RS 38 three-phase and RS 50**

- |   |       |  |
|---|-------|--|
| 1 | Pg 11 | Three-phase power supply                                   |
| 2 | Pg 11 | Single-phase power supply                                  |
| 3 | Pg 9  | TL remote control  |
| 4 | Pg 9  | TR remote control  |
| 5 | Pg 11 | Gas valves   |
| 6 | Pg 11 | Gas pressure switch or valve leak detection control device |



After carrying out maintenance, cleaning or checking operations, reassemble the cover and all the safety and protection devices of the burner.

**4.11 Thermal relay adjustment (RS 38-50 THREE-PHASE)**

This is required to avoid motor burn-out in the event of a significant increase in power absorption caused by a missing phase.

- If the motor is star-powered, 400 V, the cursor 2) should be positioned to "MIN".
- If it is delta-powered, 230 V, the cursor 2) should be positioned to "MAX".
- In case of an intervention of the thermal relay, press button 1).

Even if the scale of the thermal relay does not include rated motor absorption at 400 V, protection is still ensured in any case.

The RS 38 and RS 50 three-phase models leave the factory pre-set for **400 V** power supply. If **230 V** power supply is used, change the motor connection from star to delta and change the calibration of the thermal relay as well.

The RS 28-38-50 burners leave the factory ready for two-stage operation and must therefore be connected to the TR remote control.

Instead, if burner single-stage operation is required, replace the TR remote control with a jumper between terminals T6 - T7 of plug X4.

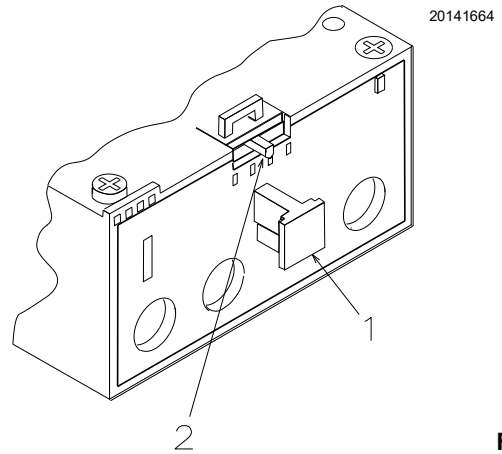

**Fig. 19**

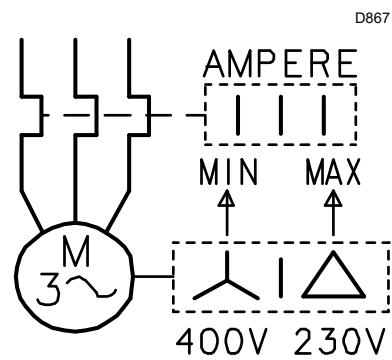

**Fig. 20**

**5 Start-up, calibration and operation of the burner**

**5.1 Notes on safety for the first start-up**



The first start-up of the burner must be carried out by qualified personnel, as indicated in this manual and in compliance with the standards and regulations of the laws in force.



**Before starting up the burner, refer to section "Safety test - with no gas supply" on page 30.**



Check the correct working of the adjustment, command and safety devices.

**5.2 Adjustments prior to ignition**

Combustion head adjustment is already described on page 17.

In addition, the following adjustments must also be made:

- open the manual valves upstream of the gas train.
- Adjust the minimum gas pressure switch to the start of the scale (Fig. 25 on page 26).
- Adjust the air pressure switch to the start of the scale (Fig. 24 on page 26).
- Purge the air from the gas line. We recommend using a plastic tube routed outside the building and to purge air until gas is smelt.
- Fit a U-type pressure gauge (Fig. 21) to the gas pressure test point on the pipe coupling.
- Used to approximately calculate burner output in the 2nd stage using the Tab. F on page 19.
- Connect two lamps or testers in parallel to the two gas line solenoid valves VR and VS in order to check the exact moment at which voltage is supplied. This operation is not required if each of the two solenoid valves is equipped with a pilot light that signals voltage passing through.



Before starting up the burner, it is good practice to adjust the gas train so that ignition takes place in conditions of maximum safety, i.e. with gas delivery at the minimum.

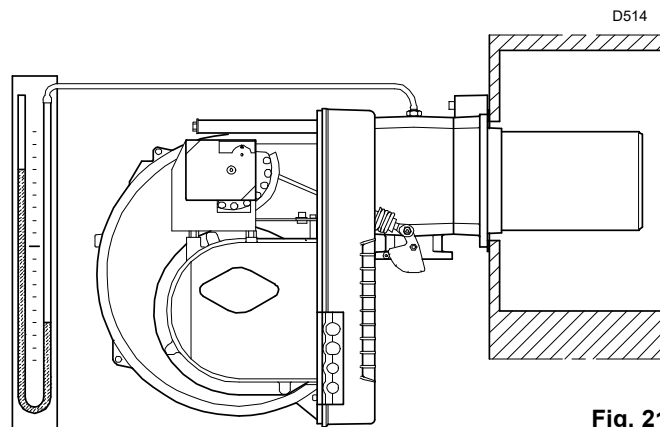

Fig. 21

**5.3 Burner start-up**

Close the remote controls and turn:

- switch 1)(Fig. 22) in "**BURNER ON**" position;
- switch 2)(Fig. 22) in "**1st STAGE**" position.

As soon as the burner starts, check that the lamps or the testers connected to the solenoid valves or the warning lights on the solenoid valves indicate no voltage presence. If voltage is present, stop the burner **immediately** and check the electrical wiring.

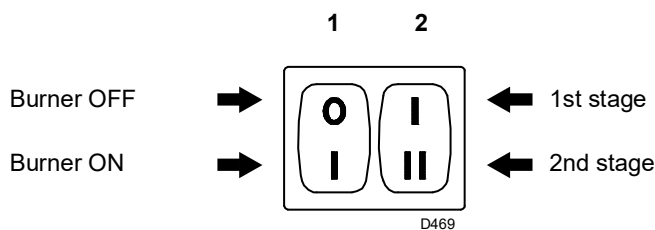

Fig. 22

**5.4 Burner ignition**

Once the above steps are completed, the burner should ignite. If the motor starts but the flame does not appear and the flame control goes into lockout, reset and wait for a new ignition attempt. If ignition does not occur, it is possible that gas is not reaching the combustion head within the safety time period of 3 seconds. Therefore, it is necessary to increase gas ignition delivery. The arrival of gas to the sleeve is indicated by the U-type pressure gauge (Fig. 21 on page 23).

If the burner locks out again, refer to chapter "Faults - Possible causes - Solutions" on page 33.



**ATTENTION**

In the event the burner stops, in order to prevent any damage to the installation, do not unblock the burner more than twice in a row. If the burner locks out for a third time, contact the customer service.



**DANGER**

In the event there are further lockouts or faults with the burner, the maintenance interventions must only be carried out by qualified, authorised personnel, in accordance with the contents of this manual and in compliance with the standards and regulations of current laws.

Once ignition has taken place, proceed with global calibration operations.

**5.5 Burner adjustment**

The optimum adjustment of the burner requires an analysis of flue gases at the boiler outlet.

Adjust in sequence:

- 1 Burner output in 2nd stage
- 2 Burner output in 1st stage
- 3 Output upon ignition
- 4 Air pressure switch
- 5 Gas minimum pressure switch

**5.5.1 Output upon ignition**



**ATTENTION**

For safety purposes and correct product operation, the ignition output, if it is adjustable, must be carried out by authorized personnel and in compliance with the standards and regulations of the laws in force.

**5.5.2 Output in 2nd stage**

2nd stage output must be selected within the firing rate range indicated in page 9.

In the above description, we left the burner running, operating in 1st stage. Now move switch 2)(Fig. 22 on page 23) to 2nd stage position: the servomotor will open the air damper and, at the same time, the gas butterfly valve at 90°.

**Adjustment of gas delivery**

Measure the gas delivery on the meter.

A rough indication can be obtained from tables on page 5, just read the gas pressure on the U-shaped pressure gauge, see Fig. 21 on page 23, and follow the instructions given in page 19.

If delivery needs to be reduced, diminish outlet gas pressure; if it is already very low, slightly close the VR adjustment valve.

If delivery needs to be increased, increase outlet gas pressure.

**Air adjustment**

Progressively adjust the end profile of cam 3)(Fig. 23) by turning the screws 5).

Turn the screws clockwise to increase air delivery.

Turn the screws anticlockwise to reduce air delivery.

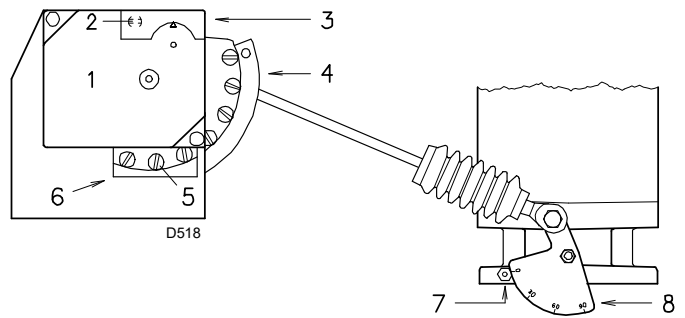

**Fig. 23**

- 1 Servomotor
- 2 ⊖ Cam 4) engaged/ ⊕ disengaged
- 3 Cam cover
- 4 Variable profile cam
- 5 Screws for adjusting the adjustable profile
- 6 Opening for access to screws 5)
- 7 Index for graduated sector 8)
- 8 Gas butterfly valve graduated sector

### 5.5.3 Output in 1st stage

1st stage output must be selected within the firing rate range indicated on page 9.

Move the switch 2)(Fig. 22 on page 23) in "1st STAGE" position: the servomotor 1)(Fig. 23) will close the air damper and, at the same time, will also close the gas butterfly valve to 15°, i.e. to the factory setting.

#### Adjustment of gas delivery

Measure the gas delivery on the meter.

- If it is necessary to reduce it, slightly decrease the angle of orange lever (Fig. 27 on page 27) with small, regular movements, i.e. bring it from an angle of 15° to 13° - 11°...
- If it is necessary to increase it, pass to 2nd stage by activating switch 2)(Fig. 22 on page 23) and slightly increase the angle of the orange lever with small, regular movements, i.e. bring it from an angle of 15° to 17° - 19°...  
Then go back to 1st stage and measure the gas delivery.

#### NOTE:

**The servomotor only follows the adjustment of the orange lever when the angle of the cam is reduced. If the angle needs to be increased, pass to the 2nd stage and increase the angle, then return to the 1st stage to check the effect of the adjustment.**

#### Adjustment of air delivery

Progressively adjust the initial profile of the cam 3)(Fig. 23) by turning the screws 4). If possible, do not turn the first screw, since this is used to set the air damper to its fully closed position.

### 5.5.4 Intermediate outputs

#### Adjustment of gas delivery

No adjustment is required

#### Adjustment of air delivery

Turn off the burner using the switch 1)(Fig. 22 on page 23) and turn the intermediate screws of the cam so that the cam tilt is progressive.

Pay attention not to move the screws at the ends of the cam, previously adjusted to open the air damper in 1st and 2nd stage.

#### NOTE:

**Once adjustment of "2nd stage - 1st stage - intermediate" outputs has been completed, recheck the ignition: its noise must be equal to the one of the following operation. If you notice any sign of pulsations, reduce the ignition stage delivery.**

**5.6 Pressure switch adjustment**

**5.6.1 Air pressure switch**

Adjust the air pressure switch after performing all other burner adjustments with the air pressure switch set to the start of the scale (Fig. 24).

With the burner operating in 1st stage, increase adjustment pressure by slowly turning the relevant knob clockwise until the burner locks out.

Then turn the knob anti-clockwise by about 20% of the set point and repeat burner starting to ensure it is correct.

If the burner locks out again, turn the knob slightly anticlockwise.



**ATTENTION**

as a rule, the air pressure switch must limit the CO in the fumes to less than 1% (10,000 ppm). To check this, insert a combustion analyser into the chimney, slowly close the fan suction inlet (for example with cardboard) and check that the burner locks out, before the CO in the fumes exceeds 1%.

The incorporated air pressure switch can work in a 'differential' mode if connected with two pipes. If a strong depression in the combustion chamber during the pre-purging phase does not allow the air pressure switch to switch, this can be obtained by applying a second tube between the air pressure switch and the suction inlet of the fan. In this way, the pressure switch will work in differential mode.



**ATTENTION**

The use of the air pressure switch with differential operation is allowed only in industrial applications and where rules enable the air pressure switch to control only fan operation without any reference to CO limit.

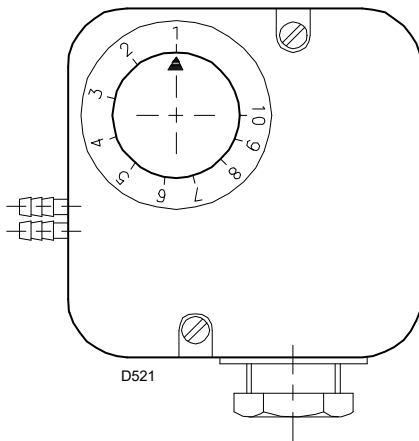

**Fig. 24**

**5.6.2 Gas minimum pressure switch**

The purpose of the minimum gas pressure switch is to prevent the burner from operating in an unsuitable way due to too low gas pressure.

Adjust the minimum gas pressure switch (Fig. 25) after having adjusted the burner, the gas valves and the gas train stabiliser. With the burner operating at maximum output:

- install a pressure gauge downstream of the gas train stabiliser (for example at the gas pressure test point on the burner combustion head);
- choke slowly the manual gas cock until the pressure gauge detects a decrease in the pressure read of about 0.1 kPa (1 mbar). In this phase, verify the CO value which must always be less than 100 mg/kWh (93 ppm).
- Increase the adjustment of the gas pressure switch until it intervenes, causing the burner shutdown;
- remove the pressure gauge and close the cock of the gas pressure test point used for the measurement;
- open completely the manual gas cock.



**ATTENTION**

1 kPa = 10 mbar

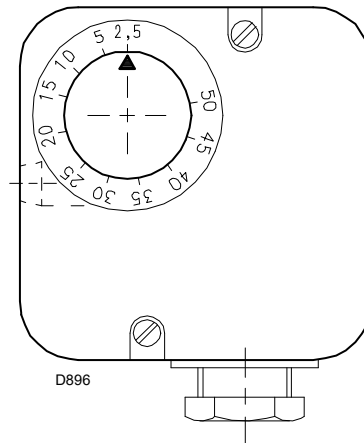

**Fig. 25**

**5.6.3 Flame presence check**

The burner is fitted with an ionisation system to check that a flame is present. The minimum current required for the flame control operation is 5 µA. The burner supplies a significantly higher current value, so that no check is usually needed. However, if it is necessary to measure the ionisation current, disconnect the plug-socket 19)(Fig. 4 on page 11) on the ionisation probe cable and insert a direct current microammeter with a base scale of 100 µA. Carefully check polarities.

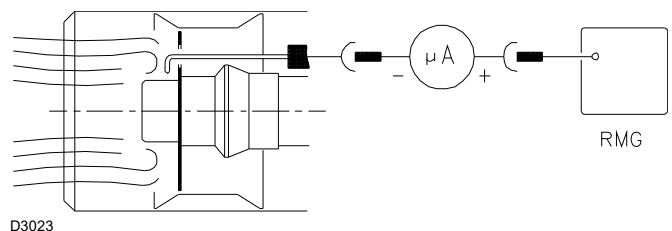

**Fig. 26**

## 5.7 Servomotor adjustment

The servomotor provides simultaneous adjustment of the air damper, by means of the variable profile cam and the gas butterfly valve.

The angle of rotation of the servomotor is equal to the angle on the graduated sector controlling the gas butterfly valve. The servomotor rotates 90° in 12 s.

Do not alter the factory setting for the 4 cams; just check that they are as specified below:

**Cam St2** : 90°

Limits rotation toward maximum position. When the burner is operating in 2nd stage, the gas butterfly valve must be fully open: 90°.

**Cam St0** : 0°

Limits rotation toward minimum position. When the burner is shut down, the air damper and gas butterfly valve must be closed: 0°

**Cam St1** : 15°

Adjusts the ignition position and the output of the 1st stage.

**Cam MV** : not used



Fig. 27

**5.8 Burner operation**

**5.8.1 Burner start-up**

Control remote control TL closes.

Servomotor start-up: turn to the right until the angle set on the cam with the orange lever.

After about 3s:

- 0 s** The flame control starting cycle begins.
- 2 s** Fan motor start-up.
- 3 s** Servomotor start-up: turn to the right, until the contact intervenes on the cam with the red lever.  
The air damper is positioned to 2nd stage output.  
Pre-purging phase with air flow rate of 2nd stage output. Duration 25 s.
- 28 s** Servomotor start-up: turn to the left until the angle set on the cam with the orange lever.
- 43 s** Ignition electrode strikes a spark.  
The air damper and gas butterfly valve are in 1st stage output position.  
The safety valve VS opens, along with the adjustment valve VR, quick opening. The flame ignites with a small output, point A. The output gradually increases, and the valve slowly opens, until 1st stage output is reached, point B.
- 45 s** The spark goes out.
- 53 s** If the TR remote control is closed or replaced by a jumper, the servomotor goes on rotating until the cam intervenes with the red lever, bringing the air damper and gas butterfly valve to the 2nd stage position, tract C-D.  
End of flame control program.

**5.8.2 Full-running operation - System equipped with TR remote control**

Once the start-up cycle is completed, the servomotor command moves on to the TR remote control, that controls the pressure or temperature in the boiler, point D.

(The flame control still continues to check the presence of the flame and the correct position of the air pressure switch).

- When the temperature or pressure increases and opens the TR, the servomotor closes the gas butterfly valve and air damper, and the burner goes from the 2nd to the 1st operating stage, tract E-F.
- When the temperature or pressure falls and closes the TR, the servomotor opens the gas butterfly valve and air damper, and the burner goes from the 1st to the 2nd operating stage. And so on.
- The burner stops when the heat request is less than the amount of heat delivered by the burner in the 1st stage, tract G-H. The TL remote control opens, the servomotor goes back to angle 0° limited by the cam with light blue lever. The air damper closes completely to reduce heat losses to a minimum.

**System not equipped with control device TR (jumper wire installed)**

The burner is fired as described above. Then, if the temperature or pressure increases until the TL opening, the burner shuts down (tract A-A in the diagram).

**STANDARD IGNITION**  
(no. = seconds from instant 0)

D3028

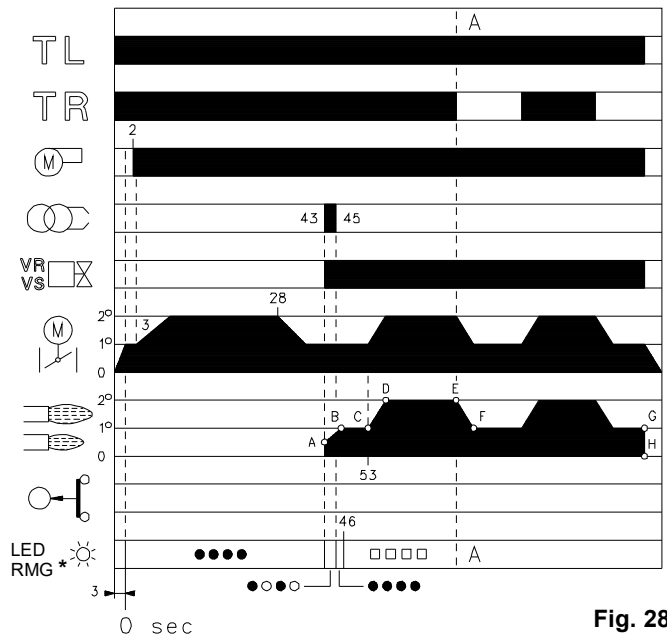

**Fig. 28**

\* ▲ Off ○ Yellow ● Green □ Red

For further details see page 29.

**5.8.3 Ignition failure**

If the burner does not fire, it goes into lockout within 3 s from opening of the gas valve and within 49 s from closure of the TL remote control. The red LED of the flame control comes on.

**Burner flame goes out during operation**

If the flame accidentally goes out during operation, the burner will go into lockout within 1s.

**IGNITION FAILURE**

D3029

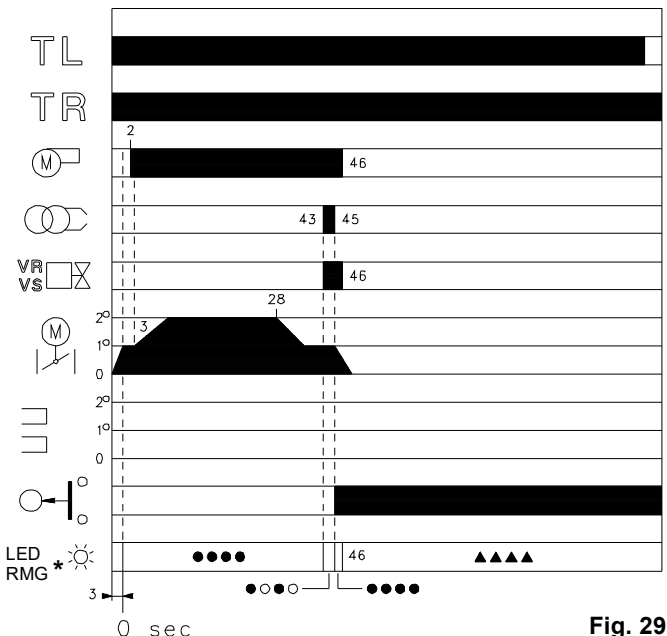

**Fig. 29**

\* ○ Off ● Yellow ▲ Red

For further details see page 29.

**5.9 Burner start-up cycle diagnostics**

During start-up, indication is according to the colour code table (Tab. G).

Sequences	Colour code
Pre-purging	●●●●●●●●●●
Ignition phase	●○●○●○●○●○●○
Operation, flame OK	□□□□□□□□□□
Operation with weak flame signal	□○□○□○□○□○□○
Electrical supply below ~ 170V	●▲●▲●▲●▲●▲●▲
Lockout	▲▲▲▲▲▲▲▲▲▲
Extraneous light	▲□▲□▲□▲□▲□▲□

Tab. G

Key (Tab. G):

○ Off   ● Yellow   □ Green   ▲ Red

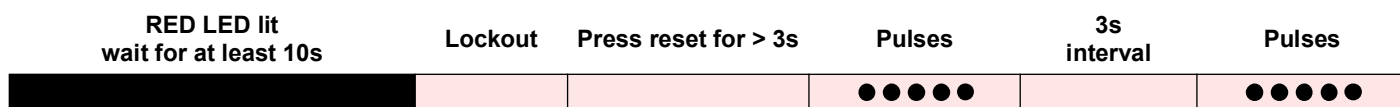

Tab. H

Below is a list of the possible methodologies for carrying out the resetting of the flame control and for using the diagnostics.

**5.9.2 flame control reset**

To reset the flame control, proceed as follows:

- Hold the button down for between 1 and 3 seconds. The burner starts up again, 2 seconds after the button is released.
- If the burner does not restart, make sure the limit thermostat is closed.

**5.9.3 Visual diagnostics**

Indicates the type of burner malfunction causing lockout. To view diagnostics, proceed as follows:

- Press and hold the button for more than 3 seconds from the steady red LED condition (burner lockout). A yellow light blinks to tell you the operation is done.
- Release the button once the light has blinked. The number of blinks indicates the reason for the malfunctioning (refer to the coding in Tab. L on page 34).

**PRESSURE ON THE BUTTON**

**STATE OF flame control**

Between 1 and 3 seconds	Reset of the flame control without displaying the visual diagnostics.
More than 3 seconds	Visual diagnostics of the lockout condition: (Led pulses at 1-second intervals).
More than 3 seconds starting from the condition of visual diagnostics	Diagnostic software using an optical interface and PC (possibility of displaying the hours the machine has been running, faults, etc.)

Tab. I

The sequence of led pulses issued by the flame control identifies the possible types of malfunction, which are listed in the table Tab. L on page 34.

**5.9.1 Resetting of flame control and diagnostics use**

The flame control supplied features a diagnostics function, through which any causes of malfunctioning can be easily identified (indicator: **RED LED**).

To use this function, you must wait at least 10 seconds once it has entered the safety condition (**lockout**), and then press the reset button.

The flame control generates a sequence of pulses (1 second apart), which is repeated at constant 3-second intervals.

Once you have seen how many times the light blinks and identified the possible cause, the system must be reset by holding the button down for 1 - 3 seconds.

**5.9.4 Software diagnostics**

Provides an analysis of the life of the burner, through optical connection with a PC showing the working hours, number and types of lockout, flame control serial number etc.

To view diagnostics, proceed as follows:

- Press and hold the button for more than 3 seconds from the steady red LED condition (burner lockout). A yellow light blinks to tell you the operation is done.
- Release the button for 1 second and then press again for over 3 seconds until the yellow light blinks again.
- Once the button is released, the red LED will flash intermittently with a higher frequency: it will then be possible to insert the optical connection.

Once the operations are done, the flame control's initial status must be restored using the resetting procedure described above.

**6 Maintenance**

**6.1 Notes on safety for the maintenance**

The periodic maintenance is essential for the good operation, safety, yield and duration of the burner.

It allows you to reduce consumption and polluting emissions and to keep the product in a reliable state over time.



The maintenance interventions and the calibration of the burner must only be carried out by qualified, authorised personnel, in accordance with the contents of this manual and in compliance with the standards and regulations of current laws.

Before carrying out any maintenance, cleaning or checking operations:



Disconnect the electrical supply from the burner by means of the main system switch.



Close the fuel shut-off valve.



Wait for the components in contact with heat sources to cool down completely.

**6.2 Maintenance programme**

**6.2.1 Maintenance frequency**



The gas combustion system should be checked at least once a year by a representative of the manufacturer or another specialised technician.

**6.2.2 Safety test - with no gas supply**

To perform commissioning in safety conditions, it is very important to check correct wiring between gas valves and burner.

For this purpose, after checking that connections comply with the burner wiring diagrams, it is necessary to carry out a start-up cycle with gas cock closed (dry test).

- 1 The manual gas valve must be closed using the locking/unlocking device ("Lock-out / tag out" procedure).
- 2 Ensure that burner limit electrical contacts are closed
- 3 Ensure that minimum gas pressure switch contact is closed
- 4 Try to start the burner.

The start-up cycle must occur according to the following steps:

- Fan motor start-up for pre-purging
- Gas valve leak detection control, if applicable.
- Pre-purging completion
- Achievement of the ignition point
- Power supply of the ignition transformer
- Supply of gas valves.

As gas is closed, the burner cannot ignite and its flame control will switch to stop or safety lockout condition.

The actual supply of gas valves can be checked by inserting a tester; some valves are equipped with lights (or closing/opening position indicators) that activate as soon as they are powered.



**IF POWER SUPPLY OF GAS VALVES OCCURS IN UNEXPECTED MOMENTS, DO NOT OPEN THE MANUAL VALVE, DISCONNECT POWER SUPPLY, CHECK WIRINGS, CORRECT THE ERRORS AND CARRY OUT THE WHOLE TEST AGAIN.**

**6.2.3 Checking and cleaning**



The operator must use the required equipment during maintenance.

**Combustion head**

Open the burner and make sure that all components of the combustion head are in good condition, not deformed by the high temperatures, free of impurities from the surroundings and correctly positioned.

**Gas filter**

Change the gas filter when it is dirty.

**Burner**

Check that there are not excess wear or loosen screws. The screws securing the electrical leads in the burner plugs should also be fully tightened.

Clean the outside of the burner.

Clean and grease the adjustable profile of the cams.

**Fan**

Check to make sure that no dust has accumulated inside the fan or on its impellers, as this condition will cause a reduction in the air flow rate and provoke polluting combustion.

**Boiler**

Clean the boiler as indicated in its accompanying instructions in order to maintain all the original combustion characteristics intact, especially: the flue gas temperature and combustion chamber pressure.

**Gas leaks**

Make sure that there are no gas leaks on the pipe between the gas meter and the burner.

**Flame inspection window**

Clean the glass of the flame inspection window.

**6.2.4 Combustion control (gas)**

Carry out an analysis of the combustion flue gases. Significant differences with respect to the previous measurements indicate the points where most care should be exercised during maintenance.

If the combustion values measured before starting maintenance do not comply with applicable Standards or do not indicate efficient combustion, consult the table below or contact our Technical Support Service to implement the necessary adjustments.

EN 676		Air excess		CO
		Max. output $\lambda \leq 1.2$	Max. output $\lambda \leq 1.3$	
GAS	Theoretical max CO <sub>2</sub> 0 % O <sub>2</sub>	CO <sub>2</sub> % Calibration		mg/kWh
		$\lambda = 1.2$	$\lambda = 1.3$	
G 20	11.7	9.7	9	≤ 100
G 25	11.5	9.5	8.8	≤ 100
G 30	14.0	11.6	10.7	≤ 100
G 31	13.7	11.4	10.5	≤ 100

**Tab. J**

**CO<sub>2</sub>**

It is advisable to adjust the burner with a CO<sub>2</sub> not greater than about 10% (gas with Ncv 8600 kcal/m<sup>3</sup>). In this way it is avoided that a small decalibration (for example a variation in the tension) could cause a combustion with an air defect and with the subsequent formation of CO.

**CO**

It should not exceed 100 mg/kWh.

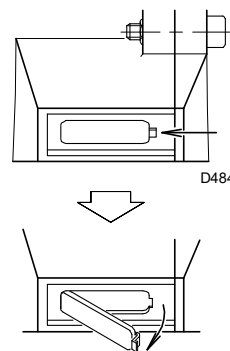

**Fig. 30**

**6.2.5 Safety components**

The safety components must be replaced at the end of their life cycle indicated in Tab. K. The specified life cycles do not refer to the warranty terms indicated in the delivery or payment conditions.

Safety component	Life cycle
Flame control	10 years or 250,000 operation cycles
Flame sensor	10 years or 250,000 operation cycles
Gas valves (solenoid)	10 years or 250,000 operation cycles
Pressure switches	10 years or 250,000 operation cycles
Pressure adjuster	15 years
Servomotor (electronic cam) (if present)	10 years or 250,000 operation cycles
Oil valve (solenoid) (if present)	10 years or 250,000 operation cycles
Oil regulator (if present)	10 years or 250,000 operation cycles
Oil pipes/ couplings (metallic) (if present)	10 years
Fan impeller	10 years or 500,000 start-ups

**Tab. K**

### 6.3 Opening the burner



Disconnect the electrical supply from the burner by means of the main system switch.



Close the fuel shut-off valve.



Wait for the components in contact with heat sources to cool down completely.

- Cut off the voltage.
- remove the screw 1)(Fig. 31) and pull out the hood 2).
- Disengage the articulated coupling 3) from the graduated sector 4).
- Remove screw 5), the split pin 9) and pull the burner back by about 100 mm on the slide bars 6.
- Disconnect the probe and electrode leads and then pull the burner fully back.
- Turn it as indicated in the diagram, and insert the split pin 9) into the hole of one of the two guides so that the burner remains in that position.

Now extract the gas distributor 7) after having removed the screw 8)(Fig. 31).

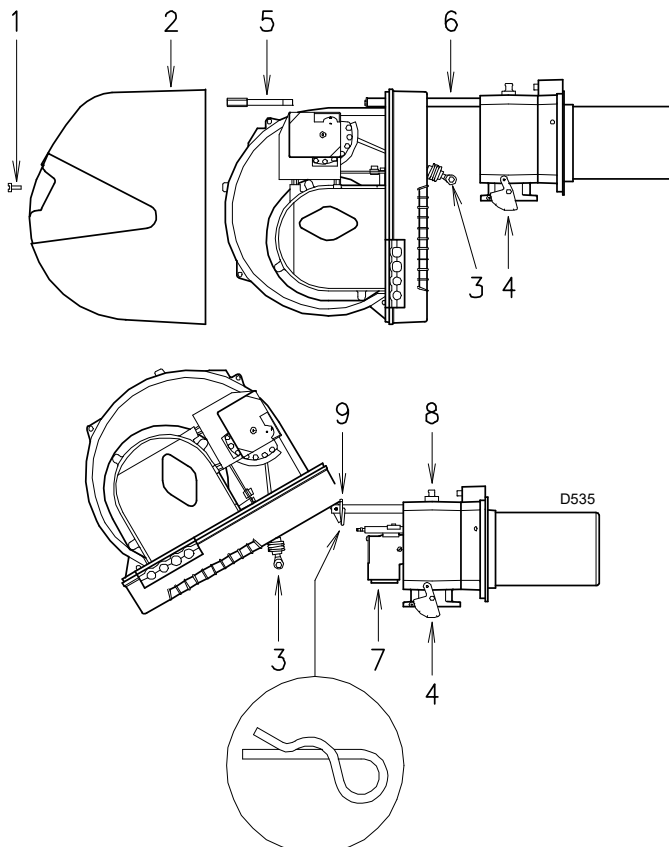

Fig. 31

### 6.4 Closing the burner

- Remove the split pin 9)(Fig. 31) and push the burner until it is approx. 100 mm from the pipe coupling. Reconnect the cables and slide in the burner until it comes to a stop. Replace the screws 5) and split pin 9) and carefully pull the probe and electrode cables outwards until they are slightly taut. Reconnect the articulated coupling 3) to the graduated sector 4).



After carrying out maintenance, cleaning or checking operations, reassemble the cover and all the safety and protection devices of the burner.

**7** Faults - Possible causes - Solutions



In the event the burner stops, in order to prevent any damage to the installation, do not unblock the burner more than twice in a row. If the burner locks out for a third time, contact the customer service.



In the event there are further lockouts or faults with the burner, the maintenance interventions must only be carried out by qualified, authorised personnel, in accordance with the contents of this manual and in compliance with the standards and regulations of current laws.

Signal	Problem	Probable cause	Suggested remedy
2 blinks ●●	Once the pre-purging phase and safety time have passed, the burner goes into lockout without the appearance of the flame.	The operation solenoid valve lets little gas through.	Increase
		One of the two solenoid valves does not open	Replace
		Gas pressure too low	Increase pressure at governor
		Ignition electrode incorrectly adjusted	Adjust it
		Electrode grounded due to broken insulation	Replace
		High voltage cable defective	Replace
		High voltage cable deformed by high temperature	Replace and protect
		Ignition transformer defective	Replace
		Incorrect valve or transformer electrical wiring	Check
		Defective flame control	Replace
		A closed valve upstream the gas train	Open
		Air in pipework	Bleed air
Gas valves unconnected or with interrupted coil	Check connections or replace coil		
3 blink ●●●	The burner does not switch on, and the lockout appears	Air pressure switch in operating position	Adjust or replace
	The burner starts and then goes into lockout	Air pressure switch does not switch owing to lack of air pressure:	
		Air pressure switch poorly adjusted	Adjust or replace
		Pressure switch pressure point pipe clogged	Clean
		Poorly adjusted head	Adjust
	Lockout during pre-purging phase	High pressure in the furnace	Connect air pressure switch to fan suction line
		Defective motor control contactor (only three-phase version)	Replace
		Defective electrical motor	Replace
Motor lockout (only three-phase version)		Replace	
4 blinks ●●●●	The burner starts and then goes into lockout	Flame simulation	Replace the flame control
	Lockout when burner stops	Permanent flame in the combustion head or flame simulation	Eliminate persistence of flame or replace flame control
6 blinks ●●●●●●	The burner starts and then goes into lockout	Defective or incorrectly adjusted servomotor	Adjust or replace
7 blinks ●●●●●●●	The burner goes into lockout immediately following the appearance of the flame	The operation solenoid lets little gas through	Increase
		Ionisation probe incorrectly adjusted	Adjust
		Insufficient ionisation (less than 5 A)	Check probe position
		Earth probe	Withdraw or replace cable
		Burner poorly earthed	Check earthing
		Phase and neutral connections inverted	Invert them
		Defective flame detection circuit	Replace the flame control
	Burner locks out when shifting from minimum to maximum output and vice versa	Too much air or too little gas	Adjust air and gas
	Burner goes into lockout during operation	Probe or ionisation cable grounded	Replace worn parts

Signal	Problem	Probable cause	Suggested remedy
10 blinks ●●●●●● ●●●●●●	The burner does not switch on, and the lockout appears	Incorrect electrical wiring	Check
	The burner goes into lockout	Defective flame control	Replace
		Presence of electromagnetic disturbances in the thermostat lines	Filter or eliminate
		Presence of electromagnetic disturbance	Use the radio disturbance protection kit
No blink	The burner does not start	No electrical power supply	Check connections
		A limiter or safety control device is open	Adjust or replace
		Line fuse blocked	Replace
		Defective flame control	Replace
		No gas supply	Open the manual valves between contactor and train
		Mains gas pressure insufficient	Contact your gas company
		Minimum gas pressure switch fails to close	Adjust or replace
		Servomotor fails to move to min. ignition position	Replace
	The burner continues to repeat the start-up cycle without lockout	The gas pressure in the gas mains lies very close to the value to which the gas pressure switch has been set. The sudden drop in pressure after valve opening causes temporary opening of the pressure switch itself, the valve immediately closes and the burner stops. Pressure increases again, the pressure switch closes again and the ignition cycle is repeated. And so on	Reduce the minimum gas pressure switch intervention pressure. Replace the gas filter cartridge.
	Ignition with pulsations	Poorly adjusted head	Adjust
		Ignition electrode incorrectly adjusted	Adjust it
		Incorrectly adjusted fan air damper: too much air	Adjust
		Output during ignition phase is too high	Reduce
	Burner does not reach maximum output	Remote control device TR fails to close	Adjust or replace
Defective flame control		Replace	
Defective servomotor		Replace	
Burner stops with air damper open	Defective servomotor	Replace	

**Tab. L**

## A Appendix - Accessories

### Kit for LPG operation

The kit allows the RS 28-38-50 burners to operate with LPG.

BURNER	RS 28		RS 38		RS 50	
Output kW	95 ÷ 325		115 ÷ 440		140 ÷ 581	
Nozzle length mm	216	351	216	351	216	351
Code	3010079	3010080	3010081	3010082	3010083	3010084

### Vibration reduction kit

BURNER	RS 28		RS 38		RS 50	
Output kW	81 ÷ 325		105 ÷ 440		116 ÷ 580	
Nozzle length mm	216	351	216	351	216	351
Code	3010198		3010199		3010200	

### Differential circuit breaker kit

Burner	Code
All models	3010329

### Software interface kit

Burner	Code
All models	3002719

### Radio disturbance protection kit

If the burner is installed in places particularly subject to radio disturbance (emission of signals exceeding 10V/m) owing to the presence of an INVERTER, or in applications where the length of the thermostat connections exceeds 20 metres, a protection kit is available as an interface between the flame control and the burner.

Burner	Code
All models	3010386

### Gas trains in compliance with EN 676

Please refer to manual.



ATTENTION

The installer is responsible for the addition of any safety device not foreseen in this manual.

**B Appendix - Electrical panel layout**

<b>1</b>	<b>Index of layouts</b>
<b>2</b>	Indication of references
	Factory made electrical system for RS 28 SINGLE-PHASE burners (DIAGRAM A)
	Factory made electrical system for RS 38 SINGLE-PHASE burners (DIAGRAM A)
	Factory made electrical system for RS 38 - RS 50 THREE-PHASE burners (DIAGRAM A)
	Electrical system external connections without valve leak detection control for RS 28-38 SINGLE-PHASE burners (DIAGRAM B)
	Electrical system external connections without valve leak detection control for RS 38 - RS 50 THREE-PHASE burners (DIAGRAM B)
	Electrical system external connections with valve leak detection control for RS 28-38 SINGLE-PHASE burners (DIAGRAM C)
	Electrical system external connections with valve leak detection control for RS 38 - RS 50 THREE-PHASE burners (DIAGRAM C)

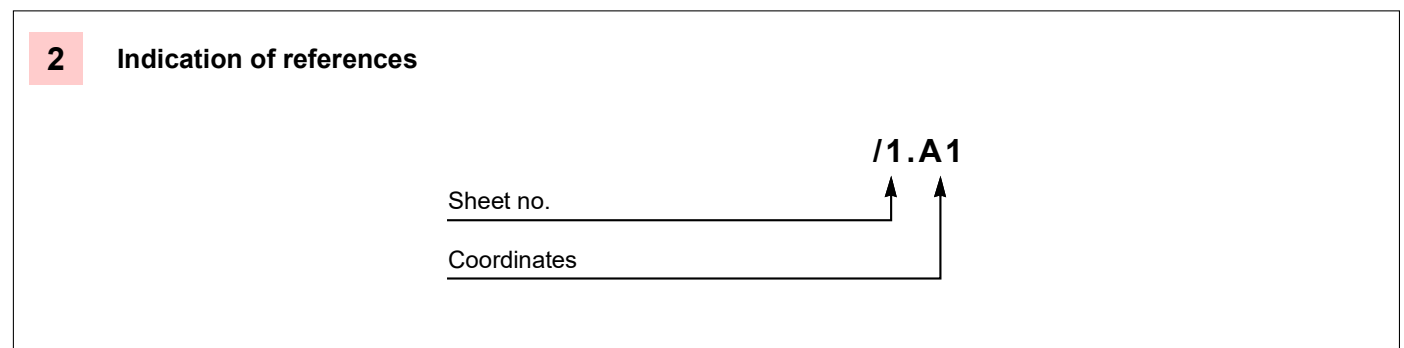

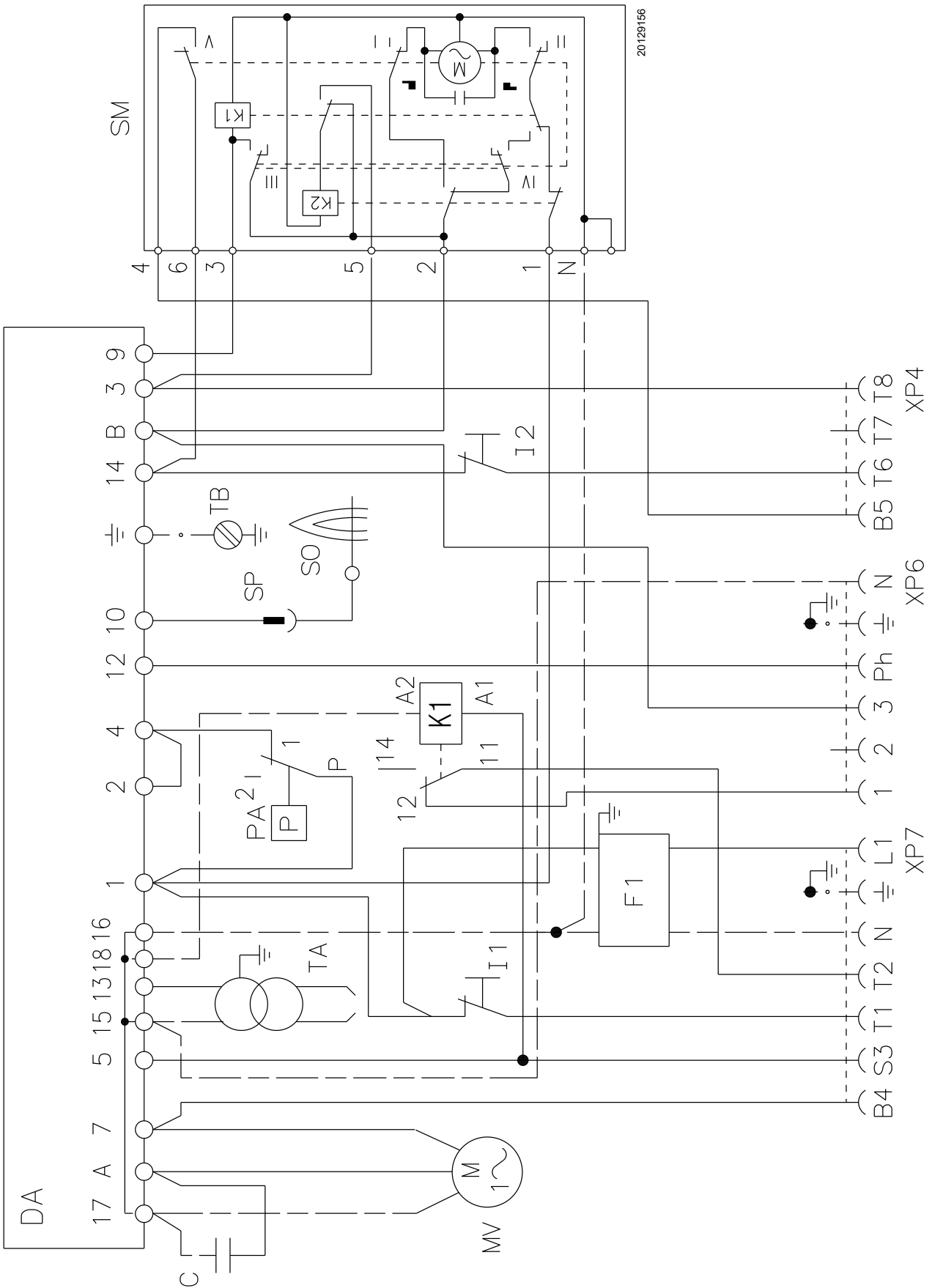



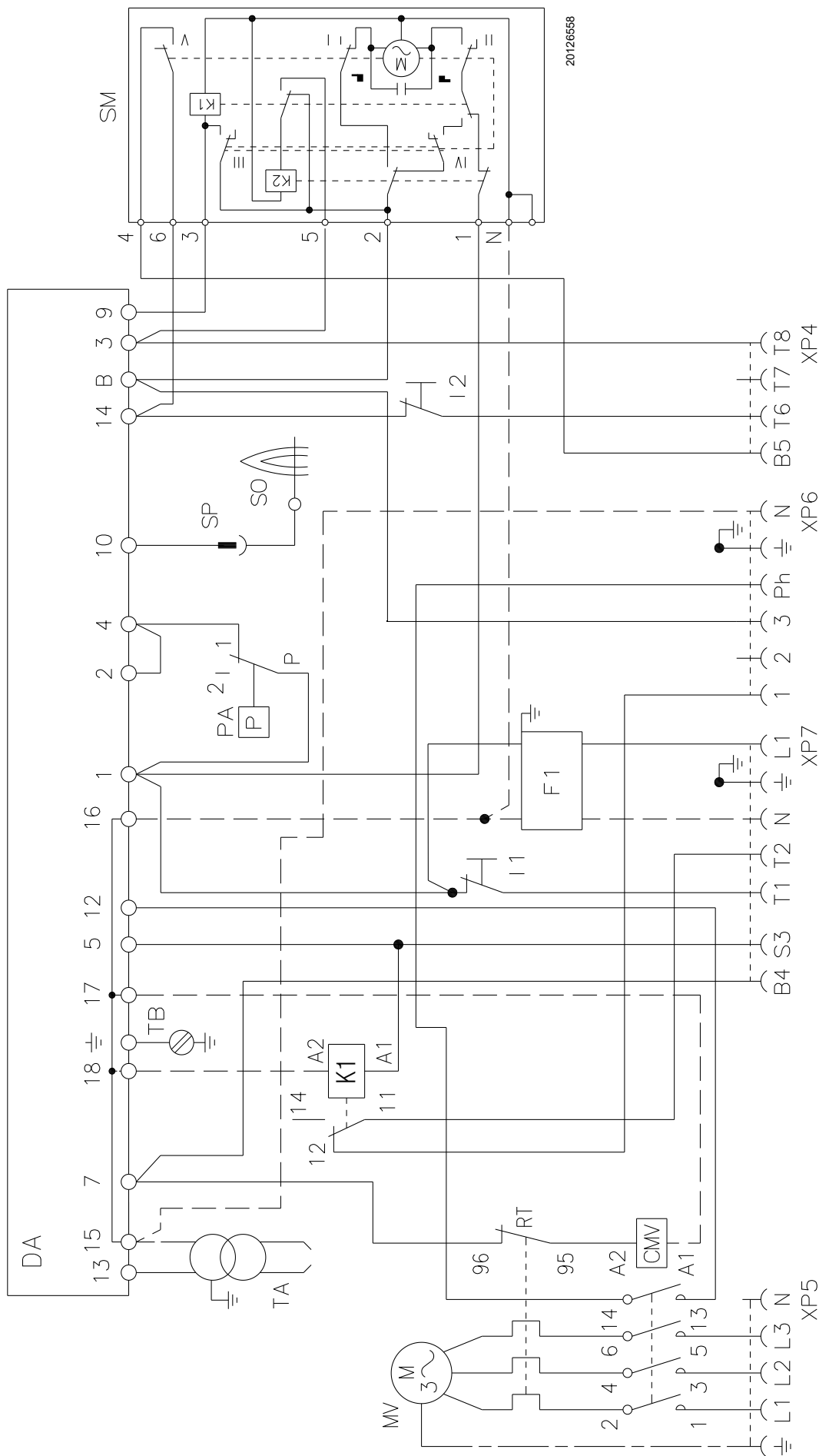

20126558

**DIAGRAM A**

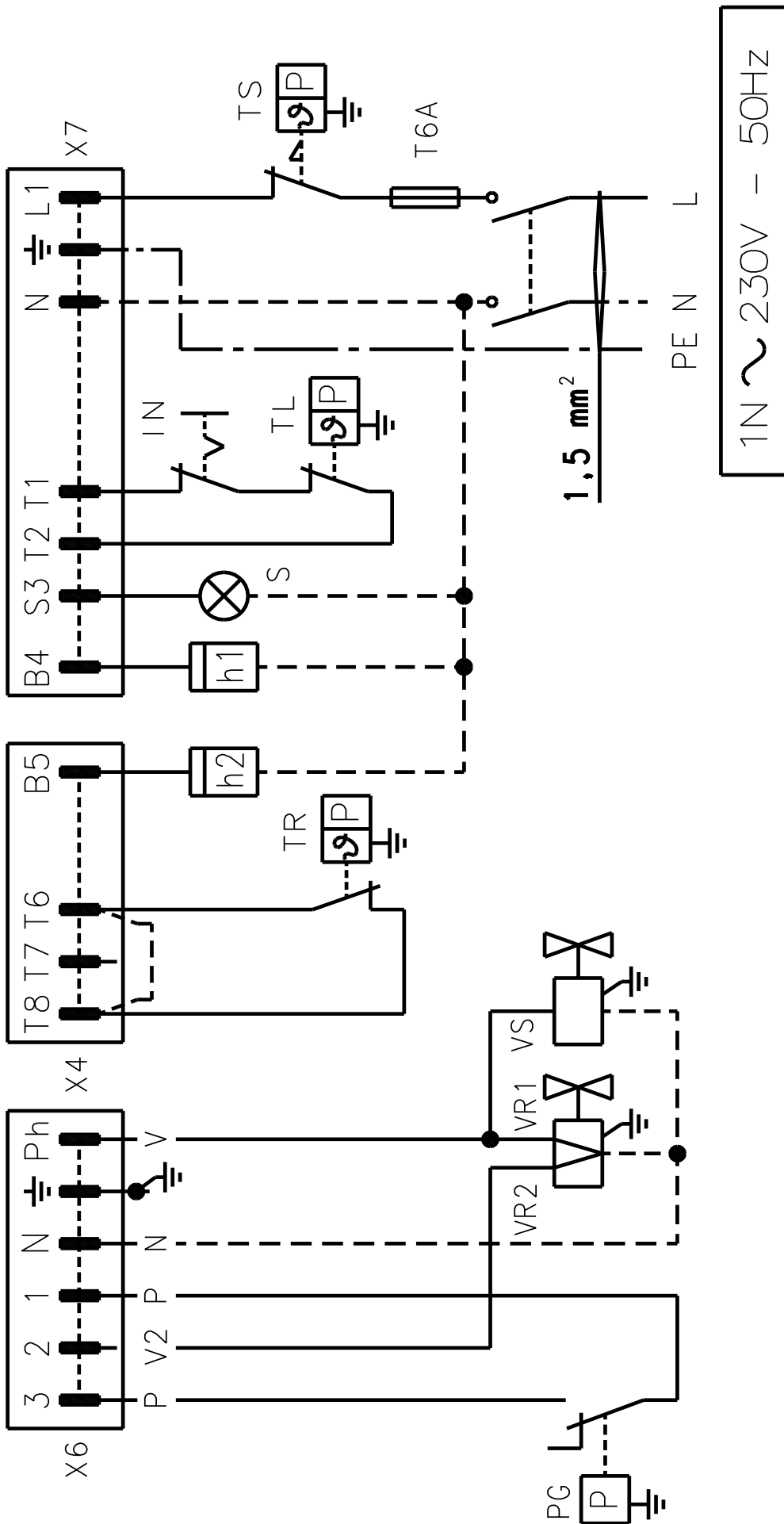

20143439

**RS 28 - RS 38 SINGLE-PHASE**

**DIAGRAM B**



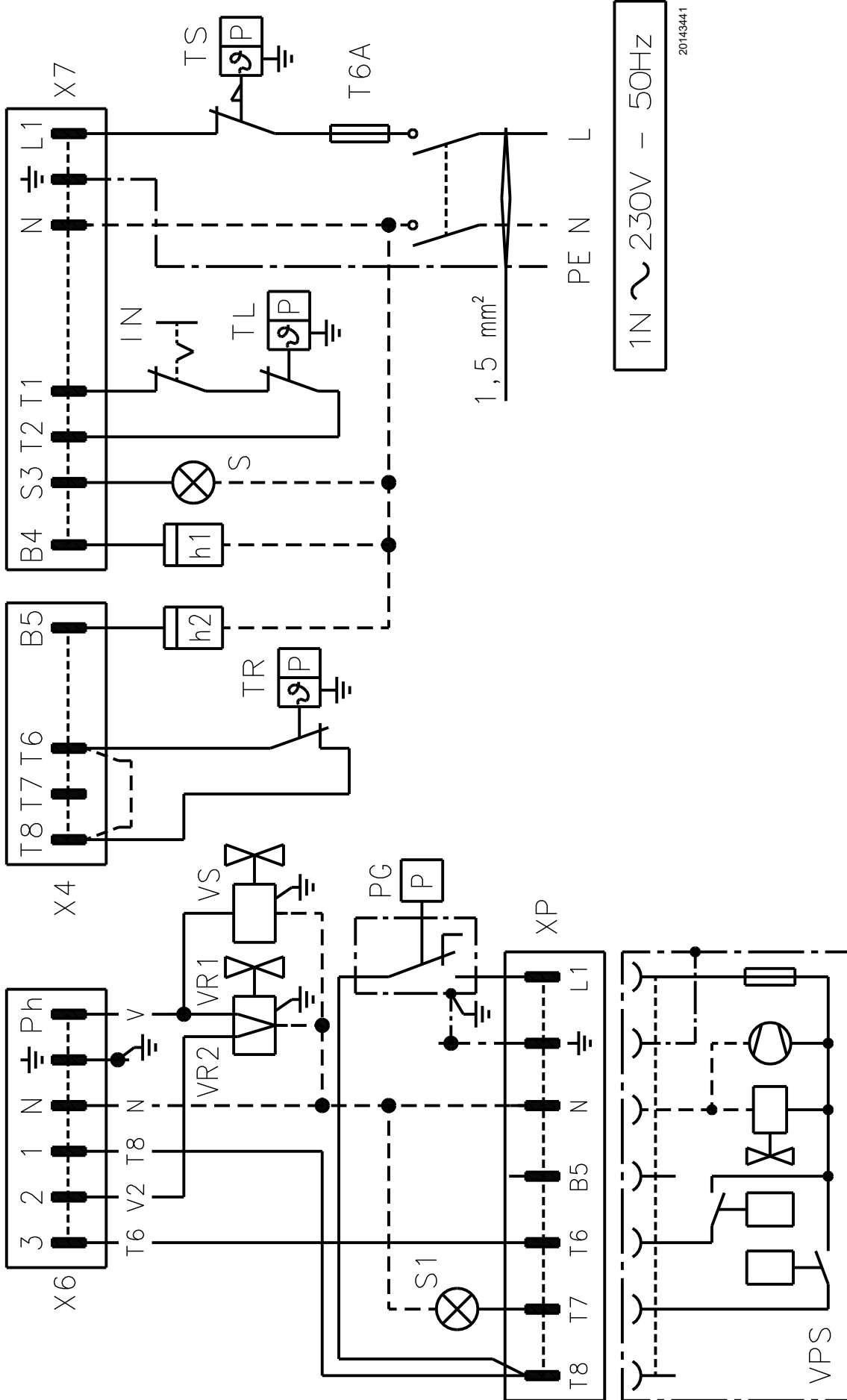

20143441

1N ~ 230V - 50HZ

RS 28 - RS 38 SINGLE-PHASE

DIAGRAM C



### WIRING DIAGRAM KEY

#### DIAGRAM A

C	Capacitor
CMV	Motor contactor
DA	Flame control
F1	Filter to protect against radio disturbance
K1	Relay
I1	Switch: burner on-off
I2	Switch: 1° - 2° stage
MV	Fan motor
PA	Air pressure switch
RT	Thermal relay
SM	Servomotor
SO	Ionisation probe
SP	Plug-socket
TA	Ignition transformer
TB	Burner earth
XP4	4-pole socket
XP5	5-pole socket
XP6	6-pole socket
XP7	7-pole socket



ATTENTION

In the case of a phase/phase power supply, it is necessary to install a jumper in the flame control terminal board, between clamp 6 and the earthing clamp.



ATTENTION

- The RS 38 and RS 50 three-phase models leave the factory pre-set for **400 V** power supply.
- If **230 V** power supply is used, change the motor connection (from star to delta) and change the calibration of the thermal relay as well.

#### DIAGRAM (B)

**Electrical connection without gas valve leak detection control**

#### DIAGRAM (C)

**Electrical connection with gas valve leak detection control**

h1	1st stage hour counter
h2	2nd stage hour counter
IN	Burner manual stop electric switch
XP	Plug for leak detection control
X4	4-pole plug
X5	5-pole plug
X6	6-pole plug
X7	7-pole plug
PC	Gas pressure switch for leak detection control
PG	Min. gas pressure switch
S	Remote lockout signal
S1	Remote lockout signal due to leak detection control
TR	Adjustment remote control: controls 1st and 2nd stage operation. If you want the burner to have one-stage operation, replace the TR with a jumper.
TL	Limit remote control: shuts down the burner when the temperature or pressure in the boiler reaches the maximum pre-set value.
TS	Safety remote control: intervenes in the event of TL failure.
VPS	Valve leak detection control device
VR	Adjustment valve
VS	Safety valve



ATTENTION

The leak detection control takes place immediately before each burner start-up.



---

**RIELLO**

RIELLO S.p.A.  
I-37045 Legnago (VR)  
Tel.: +39.0442.630111  
[http:// www.riello.it](http://www.riello.it)  
[http:// www.riello.com](http://www.riello.com)