

**GB** **Forced draught gas burners**

Progressive two-stage or modulating operation

**CE**

**UK  
CA**

**EAC**

CODE	MODEL	TYPE
3897306	RS 45/M BLU	827 T2
3897307	RS 45/M BLU	827 T2



**Translation of the original instructions**

<b>1</b>	<b>Declarations</b>	<b>3</b>
<b>2</b>	<b>Information and general warnings</b>	<b>4</b>
2.1	Information about the instruction manual	4
2.1.1	Introduction	4
2.1.2	General dangers	4
2.1.3	Other symbols	4
2.1.4	Delivery of the system and the instruction manual	5
2.2	Guarantee and responsibility	5
<b>3</b>	<b>Safety and prevention</b>	<b>6</b>
3.1	Introduction	6
3.2	Personnel training	6
<b>4</b>	<b>Technical description of the burner</b>	<b>7</b>
4.1	Burner designation	7
4.2	Models available	7
4.3	Burner categories	8
4.4	Technical data	8
4.5	Electrical data	8
4.6	Maximum dimensions	9
4.7	Firing rate	9
4.7.1	Firing rate based on the air density	10
4.8	Test boiler	11
4.8.1	Commercial boilers	11
4.9	Burner equipment	11
4.10	Burner description	12
<b>5</b>	<b>Installation</b>	<b>13</b>
5.1	Notes on safety for the installation	13
5.2	Handling	13
5.3	Preliminary checks	13
5.4	Operating position	14
5.5	Preparing the boiler	14
5.5.1	Boring the boiler plate	14
5.5.2	Blast tube length	14
5.6	Positioning the probe - electrode	15
5.7	Securing the burner to the boiler	15
5.8	Combustion head adjustment	16
5.9	Closing the burner	17
5.10	Gas feeding	18
5.10.1	Gas feeding line (Example) - Please refer to the gas train documentation for more information	18
5.10.2	Gas train	19
5.10.3	Gas train installation	19
5.10.4	Gas pressure	19
5.11	Electrical wiring	21
5.11.1	Supply cables and external connections passage	21
5.11.2	Modulating operation	22
<b>6</b>	<b>Start-up, calibration and operation of the burner</b>	<b>23</b>
6.1	Notes on safety for the first start-up	23
6.2	Adjustments prior to ignition	23
6.3	Servomotor	23
6.4	Burner start-up	24
6.5	Burner ignition	24
6.6	Burner adjustment	24
6.6.1	Output upon ignition	24
6.6.2	Maximum output	24
6.6.3	Minimum output	25
6.6.4	Intermediate outputs	26
6.7	Final adjustment of the pressure switches	26
6.7.1	Air pressure switch	26

6.7.2	Minimum gas pressure switch.....	27
6.8	Burner operation .....	28
6.8.1	Burner start-up .....	28
6.8.2	Operation .....	28
6.8.3	Ignition failure.....	28
6.8.4	Burner flame goes out during operation.....	28
6.9	Burner start-up cycle diagnostics.....	29
6.10	Resetting of flame control and diagnostics use .....	29
6.10.1	Flame control reset .....	29
6.10.2	Visual diagnostics .....	29
6.10.3	Software diagnostics .....	29
6.11	Normal operation / flame detection time .....	30
6.12	Flame presence check.....	30
6.13	Final checks (with burner operating).....	31
<b>7</b>	<b>Maintenance .....</b>	<b>32</b>
7.1	Notes on safety for the maintenance .....	32
7.2	Maintenance programme .....	32
7.2.1	Maintenance frequency.....	32
7.2.2	Safety test - with gas feeding closed .....	32
7.2.3	Checking and cleaning.....	32
7.2.4	Safety components .....	33
7.3	Opening the burner .....	34
7.4	Closing the burner.....	34
<b>8</b>	<b>Faults - Probable causes - Solutions .....</b>	<b>35</b>
<b>A</b>	<b>Appendix - Accessories .....</b>	<b>37</b>
<b>B</b>	<b>Appendix - Electrical panel layout.....</b>	<b>39</b>

**1** Declarations**Declaration of Conformity A.R. 8/1/2004 & 17/7/2009 – Belgium**

Manufacturer: RIELLO S.p.A.  
37045 Legnago (VR) Italy  
Distributed by: Tel. ++39.0442630111  
www.riello.com

This document certifies that the series of devices specified below is in compliance with the model described in the EC Declaration of Conformity and has been manufactured and distributed in compliance with the requirements defined in the Legislative Decree of January 8th 2004 and July 17th 2009.

Type of product: Forced draught gas burners  
Model: RS 45/M BLU  
Regulation applied: EN 676 and A.R. of January 8th 2004 - July 17th 2009  
Controlling organisation: Kiwa Cermet Italia S.p.A.  
Via Treviso 32-34  
I-31020 San Vendemiano (TV)  
Values measured: Max. CO: 6 mg/kWh  
Max. NOx: 65 mg/kWh

**2 Information and general warnings**

**2.1 Information about the instruction manual**

**2.1.1 Introduction**

The instruction manual supplied with the burner:

- is an integral and essential part of the product and must not be separated from it; it must therefore be kept carefully for any necessary consultation and must accompany the burner even if it is transferred to another owner or user, or to another system. If the manual is lost or damaged, another copy must be requested from the Technical Assistance Service of the area;
- is designed for use by qualified personnel;
- offers important indications and instructions relating to the installation safety, start-up, use and maintenance of the burner.

**Symbols used in the manual**

In some parts of the manual you will see triangular DANGER signs. Pay great attention to these, as they indicate a situation of potential danger.

**2.1.2 General dangers**

The **dangers** can be of **3 levels**, as indicated below.



Maximum danger level!  
This symbol indicates operations which, if not carried out correctly, cause serious injury, death or long-term health risks.



This symbol indicates operations which, if not carried out correctly, may cause serious injury, death or long-term health risks.



This symbol indicates operations which, if not carried out correctly, may cause damage to the machine and/or injury to people.

**2.1.3 Other symbols**



**DANGER: LIVE COMPONENTS**  
This symbol indicates operations which, if not carried out correctly, lead to electric shocks with lethal consequences.



**DANGER: FLAMMABLE MATERIAL**  
This symbol indicates the presence of flammable materials.



**DANGER: BURNING**  
This symbol indicates the risks of burns due to high temperatures.



**DANGER: CRUSHING OF LIMBS**  
This symbol indicates the presence of moving parts: danger of crushing of limbs.



**WARNING: MOVING PARTS**  
This symbol indicates that you must keep limbs away from moving mechanical parts; danger of crushing.



**DANGER: EXPLOSION**  
This symbol signals places where an explosive atmosphere may be present. An explosive atmosphere is defined as a mixture - under atmospheric conditions - of air and flammable substances in the form of gases, vapours, mist or dust in which, after ignition has occurred, combustion spreads to the entire unburned mixture.



**PERSONAL PROTECTION EQUIPMENT**  
These symbols indicate the equipment that must be worn and kept by the operator for protection against threats against safety and/or health while at work.



**OBLIGATION TO ASSEMBLE THE COVER AND ALL THE SAFETY AND PROTECTION DEVICES**  
This symbol signals the obligation to reassemble the cover and all the safety and protection devices of the burner after any maintenance, cleaning or checking operations.



**ENVIRONMENTAL PROTECTION**  
This symbol gives indications for the use of the machine with respect for the environment.



**IMPORTANT INFORMATION**  
This symbol indicates important information that you must bear in mind.

- This symbol indicates a list.

**Abbreviations used**

Ch.	Chapter
Fig.	Figure
Page	Page
Sec.	Section
Tab.	Table

**2.1.4 Delivery of the system and the instruction manual**

When the system is delivered, it is important that:

- the instruction manual is delivered to the user by the system manufacturer, with the recommendation to keep it in the room where the heat generator is to be installed.
- The instruction manual shows:
  - the serial number of the burner;

.....

- the address and telephone number of the nearest Assistance Centre;

.....  
 .....  
 .....

- The system supplier must carefully inform the user about:
  - the use of the system;
  - any further tests that may be required before activating the system;
  - maintenance, and the need to have the system checked at least once a year by a representative of the manufacturer or another specialised technician. To ensure a periodic check, the manufacturer recommends the drawing up of a Maintenance Contract.

**2.2 Guarantee and responsibility**

The manufacturer guarantees its new products from the date of installation, in accordance with the regulations in force and/or the sales contract. At the moment of the first start-up, check that the burner is integral and complete.



**WARNING**

Failure to observe the information given in this manual, operating negligence, incorrect installation and carrying out of non authorised modifications will result in the annulment by the manufacturer of the guarantee that it supplies with the burner.

In particular, the rights to the guarantee and the responsibility will no longer be valid, in the event of damage to things or injury to people, if such damage/injury was due to any of the following causes:

- incorrect installation, start-up, use and maintenance of the burner;
- improper, incorrect or unreasonable use of the burner;
- intervention of unqualified personnel;
- carrying out of unauthorised modifications on the equipment;
- use of the burner with safety devices that are faulty, incorrectly applied and/or not working;
- installation of untested supplementary components on the burner;
- powering of the burner with unsuitable fuels;
- faults in the fuel supply system;
- continuation of use of the burner when a fault has occurred;
- repairs and/or overhauls incorrectly carried out;
- modification of the combustion chamber with inserts that prevent the regular development of the structurally established flame;
- insufficient and inappropriate surveillance and care of those burner components most likely to be subject to wear and tear;
- use of non-original components, including spare parts, kits, accessories and optional;
- force majeure.

**The manufacturer furthermore declines any and every responsibility for the failure to observe the contents of this manual.**

### 3 Safety and prevention

#### 3.1 Introduction

The burners have been designed and built in compliance with current regulations and directives, applying the known technical rules of safety and envisaging all the potential danger situations. It is necessary, however, to bear in mind that the imprudent and clumsy use of the equipment may lead to situations of death risk for the user or third parties, as well as the damaging of the burner or other items. Inattention, thoughtlessness and excessive confidence often cause accidents; the same applies to tiredness and sleepiness.

It is a good idea to remember the following:

- The burner must only be used as expressly described. Any other use should be considered improper and therefore dangerous.

In particular:

it can be applied to boilers operating with water, steam, diathermic oil, and to other uses expressly foreseen by the manufacturer;

the type and pressure of the fuel, the voltage and frequency of the electrical power supply, the minimum and maximum deliveries for which the burner has been regulated, the pressurisation of the combustion chamber, the dimensions of the combustion chamber and the ambient temperature must all be within the values indicated in the instruction manual.

- Modification of the burner to alter its performance and destinations is not allowed.
- The burner must be used in exemplary technical safety conditions. Any disturbances that could compromise safety must be quickly eliminated.
- Opening or tampering with the burner components is not allowed, apart from the parts requiring maintenance.
- Only those parts envisaged by the manufacturer can be replaced.



The manufacturer guarantees safety and proper functioning only if all burner components are intact and positioned correctly.

#### 3.2 Personnel training

The user is the person, body or company that has acquired the machine and intends to use it for the specific purpose. He is responsible for the machine and for the training of the people working around it.

The user:

- undertakes to entrust the machine exclusively to suitably trained and qualified personnel;
- undertakes to inform his personnel in a suitable way about the application and observance of the safety instructions. With that aim, the user undertakes to ensure that everyone knows the use and safety instructions for his own duties.
- Personnel must follow all the danger and caution indications shown on the machine.
- Personnel must not carry out, on their own initiative, operations or interventions that are not within their province.
- Personnel are obliged to inform their superiors of every problem or dangerous situation that may arise.
- The assembly of parts of other makes, or any modifications, can alter the characteristics of the machine and hence compromise operating safety. The manufacturing company therefore accepts no responsibility whatsoever for any which may result from the use of non-original parts.

In addition:



- must take all the measures necessary to prevent unauthorised people gaining access to the machine;
- the user must inform the manufacturer if faults or malfunctioning of the accident prevention systems are noticed, along with any presumed danger situation;
- personnel must always use the personal protective equipment envisaged by legislation and follow the indications given in this manual.

**4 Technical description of the burner**

**4.1 Burner designation**

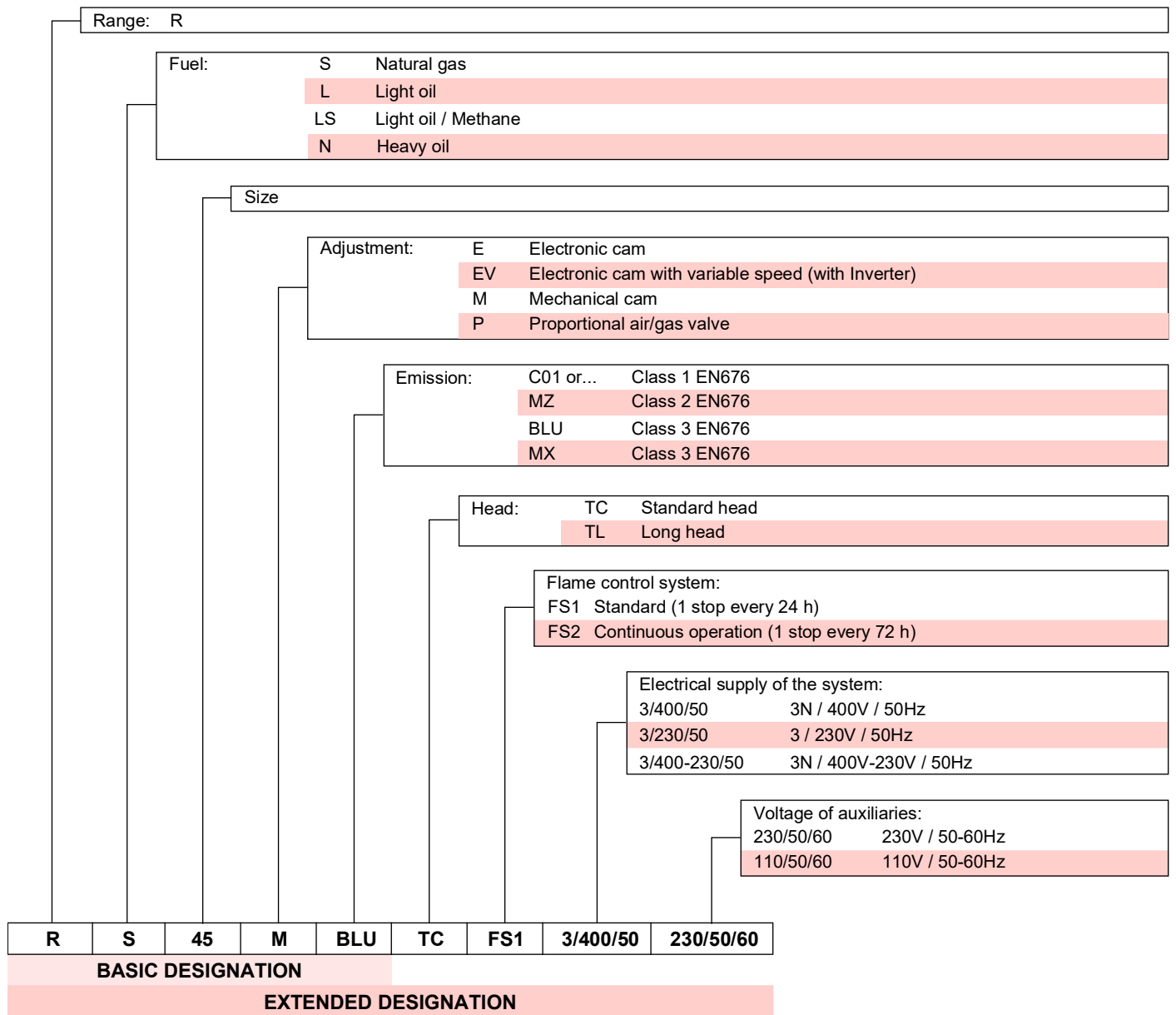

**4.2 Models available**

Designation		Power supply voltage	Start-up	Code
RS 45/M BLU	TC	1N 230V 50Hz	Direct	3897306
RS 45/M BLU	TL	1N 230V 50Hz	Direct	3897307

Tab. A

### 4.3 Burner categories

Country of destination	Gas category
AT- BG-CH-CZ-DK-EE-ES-FI-GB-GR-FR-HU-IE- IS- IT- LT- LV- NO- PT- RO-SE-SI-SK-TR	I <sub>2</sub> H
DE	I <sub>2</sub> ELL
NL	I <sub>2</sub> EK
FR	I <sub>2</sub> Er
BE	I <sub>2</sub> E(R)
LU - PL	I <sub>2</sub> E

Tab. B

### 4.4 Technical data

Model			RS 45/M BLU
Output <sup>(1)</sup>	Max.	kW Mcal/h	190 - 550 164 - 474
	Min.	kW Mcal/h	90 78
Fuel			Natural gas: G20 (methane gas) - G25
Operation			<ul style="list-style-type: none"> <li>- Intermittent (min. 1 stop in 24 hours)</li> <li>- Progressive two-stage or modulating with kit (see ACCESSORIES)</li> </ul>
Standard applications			Boilers: water, steam, diathermic oil
Ambient temperature		°C	0 - 40
Combustion air temperature		°C max	60
Noise levels <sup>(2)</sup>	Sound pressure	dB(A)	70
	Sound power		81
Weight <sup>(3)</sup>		kg	41 - 43
CE			CE-0476DP3335

Tab. C

<sup>(1)</sup> Reference conditions: Ambient temperature 20°C - Gas temperature 15°C - Barometric pressure 1013 mbar - Altitude 0 m a.s.l.

<sup>(2)</sup> Sound pressure measured in manufacturer's combustion laboratory, with burner operating on test boiler and at maximum rated output. The sound power is measured with the "Free Field" method, as per EN 15036, and according to an "Accuracy: Category 3" measuring accuracy, as set out in EN ISO 3746.

<sup>(3)</sup> Blast tube: short - long.

### 4.5 Electrical data

Model			RS 45/M BLU
Main electrical supply			1N ~230V 50Hz
Absorbed electrical power		W max	600
Protection level			IP 44

Tab. D

**4.6 Maximum dimensions**

The maximum dimensions of the burner are given in Fig. 1.

The dimensions of the open burner are indicated by position H.

Bear in mind that inspection of the combustion head requires the burner to be opened and the rear part drawn back on the slide bars.

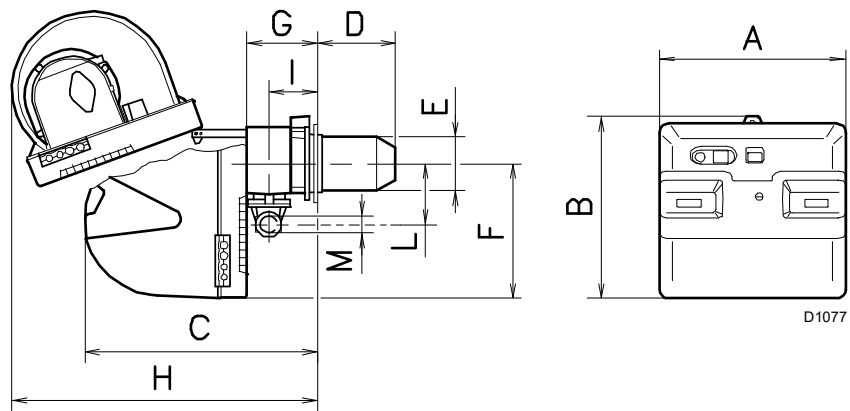

**Fig. 1**

mm	A	B	C	D <sup>(1)</sup>	E	F	G	H	I	L	M
RS 45/M BLU	476	474	580	240 - 354	160	352	164	810	108	168	1"1/2

**Tab. E**

(1) Blast tube: short-long

**4.7 Firing rate**

During operation, burner output varies between:

- a **MAXIMUM OUTPUT**, selected within area A (Fig. 2);
- and a **MINIMUM OUTPUT**, that should not be less than the minimum limit of the diagram.



The firing rate value (Fig. 2) has been obtained considering an ambient temperature of 20 °C, an atmospheric pressure of 1013 mbar (approx. 0 m a.s.l.), and with the combustion head adjusted as shown on page 16.

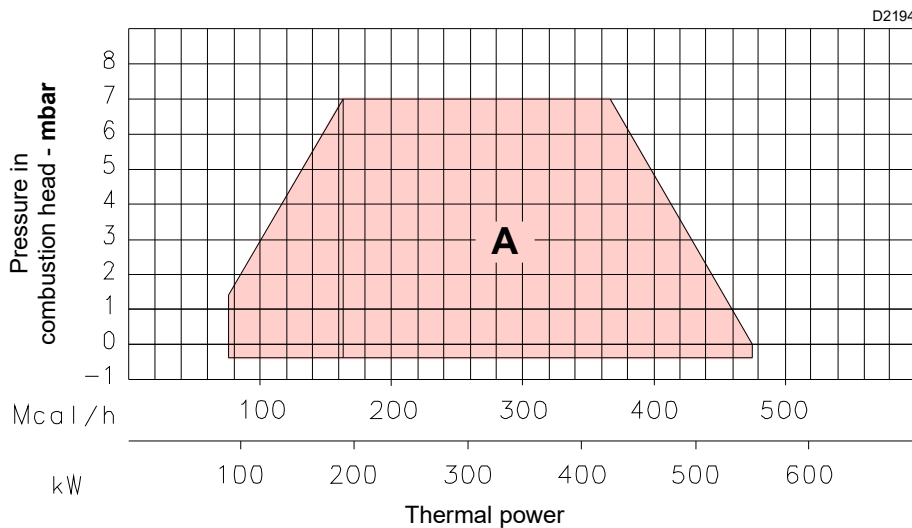

**Fig. 2**

**4.7.1 Firing rate based on the air density**

The firing rate of the burner indicated in the manual refers to an ambient temperature of 20°C and an altitude of 0 m. above sea level. (barometric pressure about 1013 mbar).

It may happen that a burner has to operate with combustion air at a higher temperature and/or higher altitudes.

The heating of the air and the increase in altitude produce the same effect: the expansion of the air volume (i.e. the reduction of its density).

The delivery of the burner fan remains essentially the same, but the oxygen per m<sup>3</sup> of air, and the thrust (discharge head) of the fan are reduced.

It is therefore important to know if the maximum output requested from the burner at a determinate combustion chamber pressure remains within the firing rate of the burner even with the changed temperature and altitude conditions.

To check it, proceed as follows:

- 1 find the corrective factor F, relating to the air temperature and altitude of the system, in Tab. F.
- 2 Divide the output Q required from the burner by F to obtain the equivalent output Qe:

$$Q_e = Q : F \text{ (kW)}$$

- 3 In the firing rate of the burner, mark the work point identified by:

Qe = equivalent output

H1 = pressure in combustion chamber point A that must remain within the firing rate.

- 4 Trace a vertical line from point A) (Fig. 3), and find the maximum pressure H2 of the firing rate.

- 5 Multiply H2 by F to obtain the maximum lowered pressure H3 of the firing rate

$$H3 = H2 \times F \text{ (mbar)}$$

If H3 is greater than H1)(Fig. 3), the burner can supply the required output.

If H3 is less than H1, it is necessary to reduce the burner output. The reduction in output is accompanied by a reduction in combustion chamber pressure:

Qr = reduced output

H1r = reduced pressure

$$H1r = H1 \times \left(\frac{Qr}{Q}\right)^2$$

**Example**, 5% reduction in output:

$$Qr = Q \times 0.95$$

$$H1r = H1 \times (0.95)^2$$

With the new values - Qr and H1r - repeat steps 2 - 5.



The combustion head should be adjusted in relation to the equivalent output Qe.

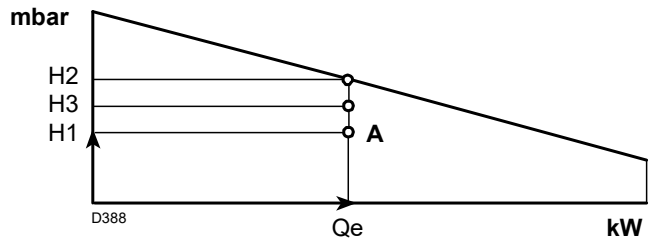

**Fig. 3**

Altitude	Average barometric pressure	F							
		Air temperature °C							
m. a.s.l.	mbar	0	5	10	15	20	25	30	40
0	1013	1.087	1.068	1.049	1.031	1.013	0.996	0.980	0.948
100	1000	1.073	1.054	1.035	1.017	1.000	0.983	0.967	0.936
200	989	1.061	1.042	1.024	1.006	0.989	0.972	0.956	0.926
300	978	1.050	1.031	1.013	0.995	0.978	0.962	0.946	0.916
400	966	1.037	1.018	1.000	0.983	0.966	0.950	0.934	0.904
500	955	1.025	1.007	0.989	0.972	0.955	0.939	0.923	0.894
600	944	1.013	0.995	0.977	0.960	0.944	0.928	0.913	0.884
700	932	1.000	0.982	0.965	0.948	0.932	0.916	0.901	0.872
800	921	0.988	0.971	0.954	0.937	0.921	0.906	0.891	0.862
900	910	0.977	0.959	0.942	0.926	0.910	0.895	0.880	0.852
1000	898	0.964	0.946	0.930	0.914	0.898	0.883	0.868	0.841
1200	878	0.942	0.925	0.909	0.893	0.878	0.863	0.849	0.822
1400	856	0.919	0.902	0.886	0.871	0.856	0.842	0.828	0.801
1600	836	0.897	0.881	0.866	0.851	0.836	0.822	0.808	0.783
1800	815	0.875	0.859	0.844	0.829	0.815	0.801	0.788	0.763
2000	794	0.852	0.837	0.822	0.808	0.794	0.781	0.768	0.743
2400	755	0.810	0.796	0.782	0.768	0.755	0.742	0.730	0.707
2800	714	0.766	0.753	0.739	0.726	0.714	0.702	0.690	0.668
3200	675	0.724	0.711	0.699	0.687	0.675	0.664	0.653	0.632
3600	635	0.682	0.669	0.657	0.646	0.635	0.624	0.614	0.594
4000	616	0.661	0.649	0.638	0.627	0.616	0.606	0.596	0.577

**Tab. F**

**4.8 Test boiler**

The firing rates were set in relation to special test boilers, according to EN 676 regulations.

In Fig. 4 you can see the diameter and length of the test combustion chamber.

**Example:**

Output 407 kW (350 Mcal/h) - diameter 50 cm, length 1.5 m.

The coupling is ensured when the boiler is EC type-approved; for boilers or ovens with combustion chambers of very different dimensions compared to those shown in the diagram of (Fig. 4) preliminary checks are recommended.

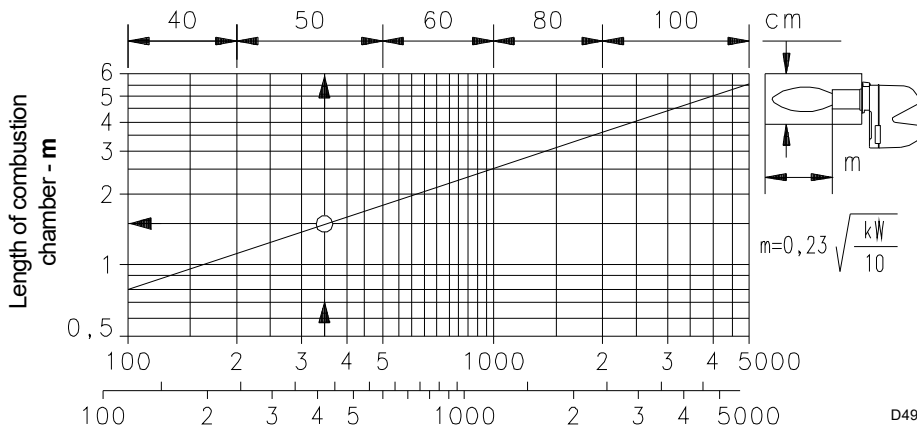

**Fig. 4**

**4.8.1 Commercial boilers**

The burner is suitable for operating on both flame inversion boilers as well as on boilers with a combustion chamber with run-off from the bottom (three flue passes) on which the best results for low NO<sub>x</sub> emissions are obtained.

The maximum thickness of the boiler front door must not exceed 200 mm (see Fig. 5).

The coupling is ensured when the boiler is EC type-approved; for boilers or ovens with combustion chambers of very different dimensions compared to those shown in the diagram of (Fig. 4) preliminary checks are recommended.

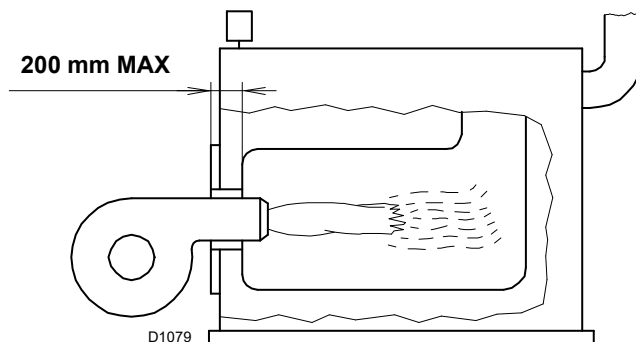

**Fig. 5**

**4.9 Burner equipment**

The burner is supplied complete with:

- Gas train flange . . . . . No. 1
- Gasket for gas train flange . . . . . No. 1
- Thermal insulation screen . . . . . No. 1
- Flange fixing screws M8 x 25 . . . . . No. 4
- M8 x 25 screws for fixing the burner flange to the boiler . . No. 4
- Cable grommets for the electrical wiring . . . . . No. 5
- Instructions . . . . . No. 1
- Spare parts list . . . . . No. 1



It is recommended to tighten the screws of the gas flange with a tightening torque of **15 Nm ±10%**.

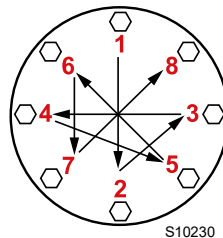

Tighten the nuts gradually (first to 30%, then to 60% up to 100%) according to the cross pattern shown in the figure.

4.10 Burner description

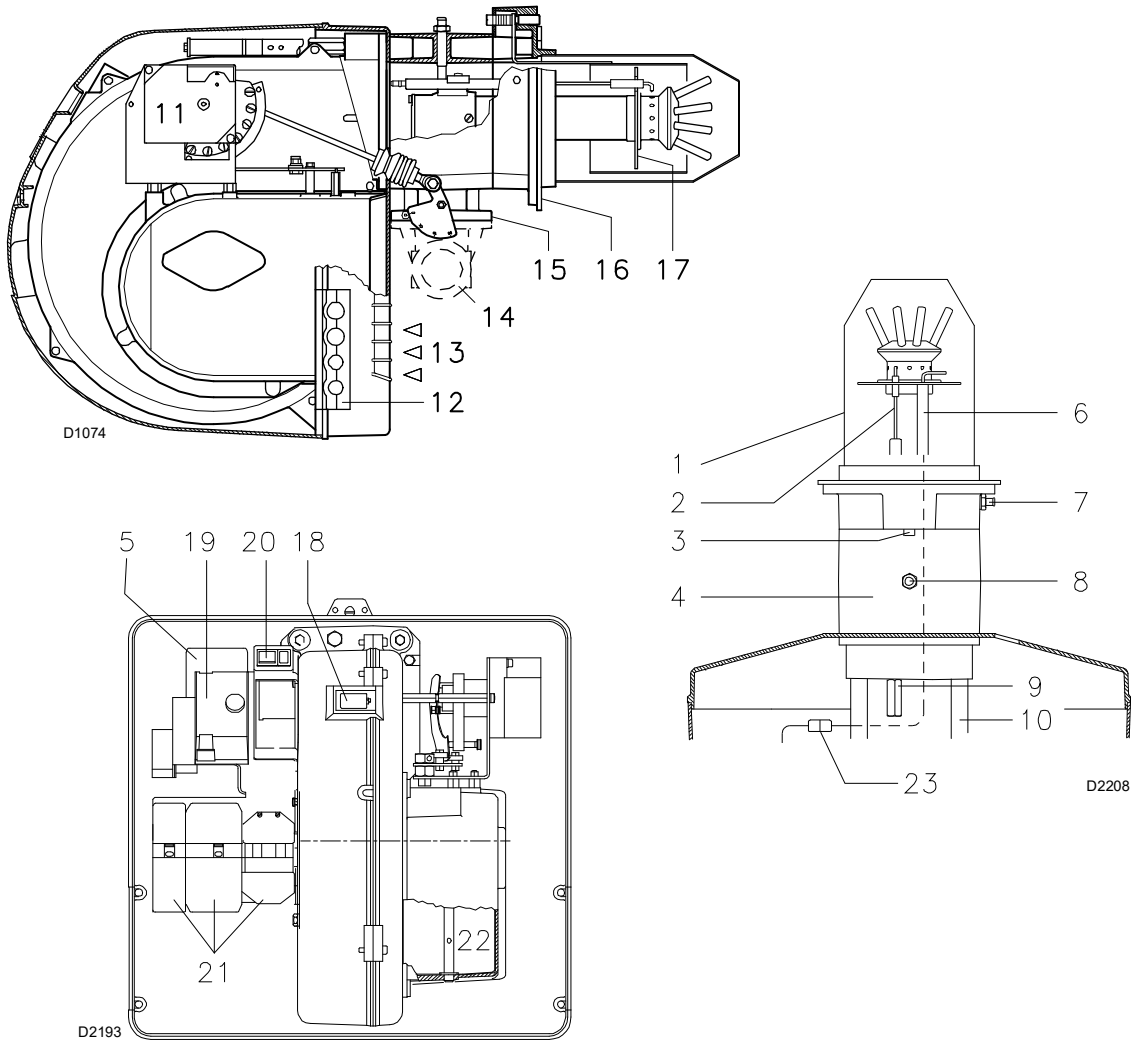

Fig. 6

- 1 Combustion head
- 2 Ignition electrode
- 3 Screw for combustion head adjustment
- 4 Pipe coupling
- 5 Minimum air pressure switch (differential type)
- 6 Flame sensor probe
- 7 Air pressure test point
- 8 Gas pressure test point and head fixing screw
- 9 Screw securing fan to pipe coupling
- 10 Slide bars for opening the burner and inspecting the combustion head
- 11 Servomotor controlling the gas butterfly valve and the air damper valve (by means of a variable profile cam mechanism).  
When the burner is not operating the air damper is fully closed in order to reduce heat dispersion from the boiler due to the flue draught which draws air from the fan suction inlet.
- 12 Plate with four hole knock-outs for electrical cable routing
- 13 Fan air inlet
- 14 Gas input pipe
- 15 Gas butterfly valve
- 16 Boiler fixing flange
- 17 Flame stability disc
- 18 Flame inspection window
- 19 Flame control with lockout pilot light and lockout reset button

- 20 Power switch for:  
automatic - manual - off  
Button for:  
power increase - power reduction
- 21 Plugs for electrical wiring
- 22 Air damper
- 23 Plug-socket on ionisation probe cable

**Flame control lockout:**

► if the flame control 19)(Fig. 6) push-button lights up, it indicates that the burner is in lockout. To reset, press the button.



### 5.4 Operating position



- The burner is designed to operate only in positions 1, 2, 3 and 4 (Fig. 8).
- Installation 1 is preferable, as it is the only one that allows the maintenance operations as described in this manual.
- Installations 2, 3 and 4 permit operation but make maintenance and inspection of the combustion head more difficult.



- Any other position could compromise the correct operation of the appliance.
- Installation 5 is prohibited for safety reasons.

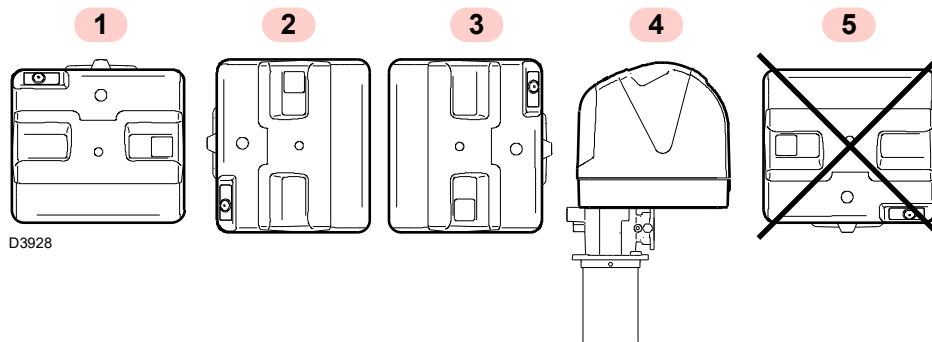

Fig. 8

### 5.5 Preparing the boiler

#### 5.5.1 Boring the boiler plate

Pierce the closing plate of the combustion chamber, as in Fig. 9. The position of the threaded holes can be marked using the thermal insulation screen supplied with the burner.

#### 5.5.2 Blast tube length

The length of the blast tube must be selected according to the indications provided by the manufacturer of the boiler, and in any case it must be greater than the thickness of the boiler door complete with its fettling.

The lengths L available are:

Blast tube	Short (mm)	Long (mm)
RS 45/M BLU	229	354

For boilers with front flue passes 13)(Fig. 12), a protection in refractory material 11) must be inserted between the boiler refractory 12) and the blast tube 10).

This protective fettling must not compromise the extraction of the blast tube.

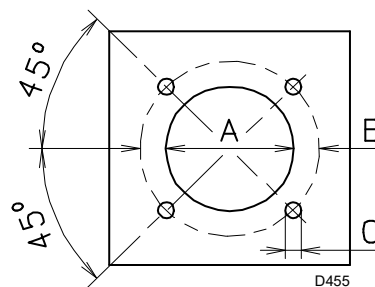

Fig. 9

mm	A	B	C
RS 45/M BLU	165	224	M 8

Tab. G

**5.6 Positioning the probe - electrode**



Before securing the burner to the boiler, check (through the opening of the blast tube) that the probe and electrode are correctly positioned, as in Fig. 11.

If the probe or electrode is not correctly positioned, you must:

- remove the screw 1)(Fig. 10)
- take out the inner part 2)(Fig. 10) of the head, and then calibrate them.



Do not rotate the probe: leave it as in Fig. 11 since if it is located too close to the ignition electrode, the flame control amplifier may be damaged.



Respect the dimensions shown in Fig. 11.

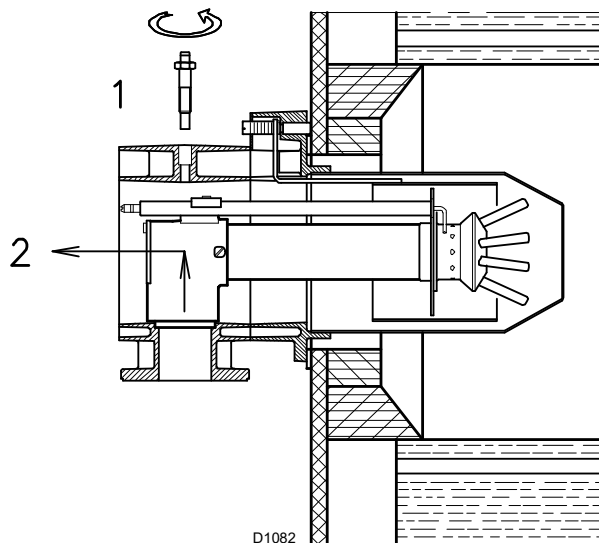

**Fig. 10**

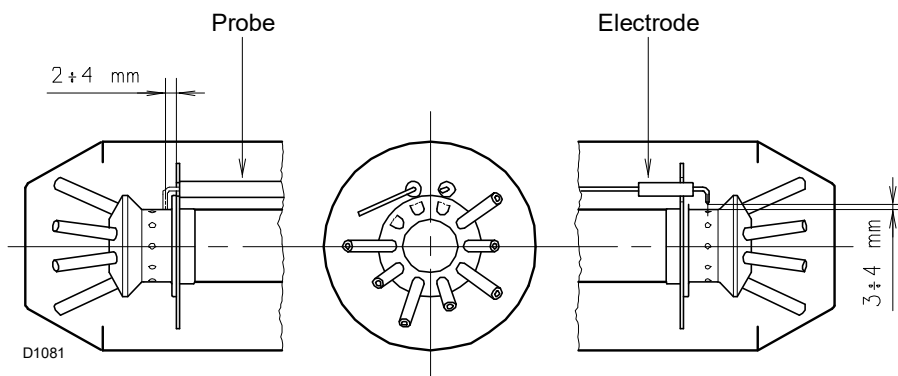

**Fig. 11**

**5.7 Securing the burner to the boiler**



Provide an adequate lifting system of the burner.

Separate the combustion head from the rest of the burner, as shown in Fig. 12; proceed as follows:

- loosen the screw 13) and remove the hood 14);
- disengage the articulated coupling 4) from the graduated sector 5);
- remove screws 2) from the two slide bars 3);
- remove screw 1) and pull the burner back on slide bars 3) by about 100 mm;
- disconnect the wires from the probe and the electrode and then pull the burner completely off the slide bars, after removing the split pin from the slide bar 3).
- Fix the flange 9) to the boiler plate interposing the insulating gasket 6) that has been supplied.
- Use the 4 screws supplied, with a tightening torque of 35 - 40 Nm, after protecting their thread with anti-seizing products.



The burner-boiler seal should be airtight; after starting the burner check that there are no leaks of no flue gases.

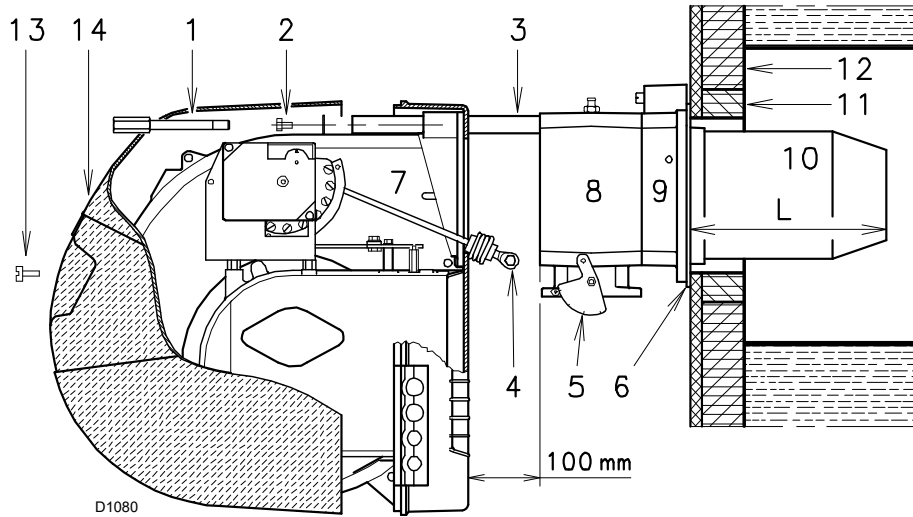

**Fig. 12**

**5.8 Combustion head adjustment**

At this stage of installation the blast tube and the pipe coupling are secured to the boiler as shown in Fig. 13.

Therefore the adjustment of the combustion head is particularly easy, an adjustment that depends solely on the maximum power of the burner.

Therefore, this value must be set before adjusting the combustion head.

There are provisions for three adjustments of the head:

- that of the external air R1;
- that of the central air R2;
- that of the gas R3.

In the diagram (Fig. 14) find the notch to which both the air and the gas should be adjusted and then:

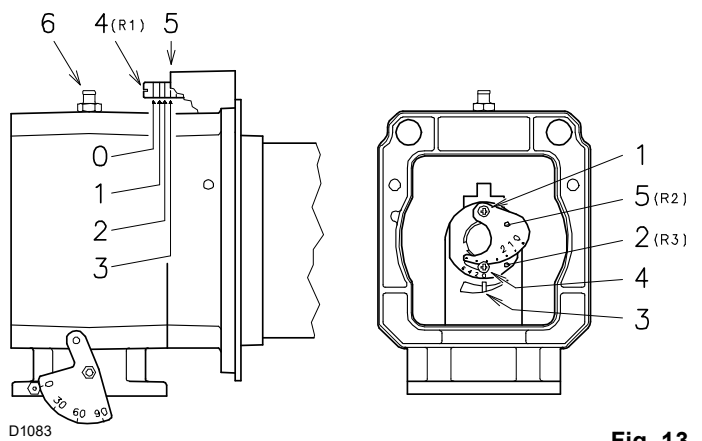

**Fig. 13**

**Adjusting R1 external air**

- Turn the screw 4)(Fig. 13) until the notch found lines up with the front surface 5) of the flange.

**Gas adjustment R3**

- Loosen the screws 1) and 4)(Fig. 13) and rotate the ring nut 2) until the notch you have found lines up with the index 3).

**Central air adjustment R2**

- Turn the shutter 5)(Fig. 13) until the notch found lines up with the screw 4).
- Block screws 1) and 4).

**Example**

Burner output = 400 kW.

The diagram (Fig. 14) shows that for this burner output the adjustments are:

- external air: R1 = notch 5.3;
- central air: R1 = notch 2.7;
- gas: R3 = notch 0.7.



The adjustments indicated can be modified during the initial start-up.

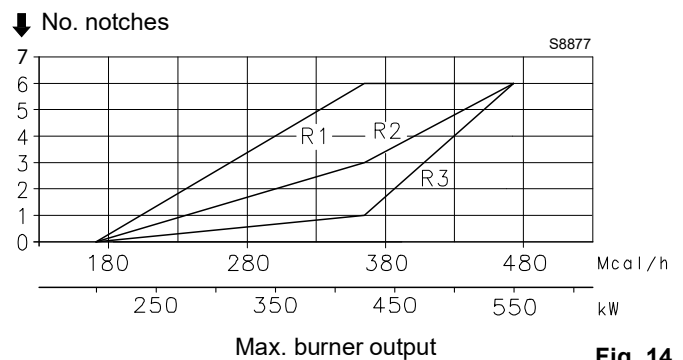

**Fig. 14**

### 5.9 Closing the burner

With the adjustment of the head completed:

- refit the burner 4) (Fig. 15) on the guides 3) at about 100 mm from the pipe coupling 5) - burner in the position shown in Fig. 12 on page 16;
- insert the probe cable and the electrode cable, then slide the burner as far as the pipe coupling, with the burner in the position shown in Fig. 15.
- Refit screws 2) on slide bars 3).

- Fix the burner to the pipe coupling with the screw 1) and put back the split pin in one of the two slide bars 3).
- Reconnect the articulated coupling 8) to the graduated sector 7).



When fitting the burner on the two slide bars, it is advisable to gently draw out the high voltage cable and the flame detection probe cable until they are slightly stretched.

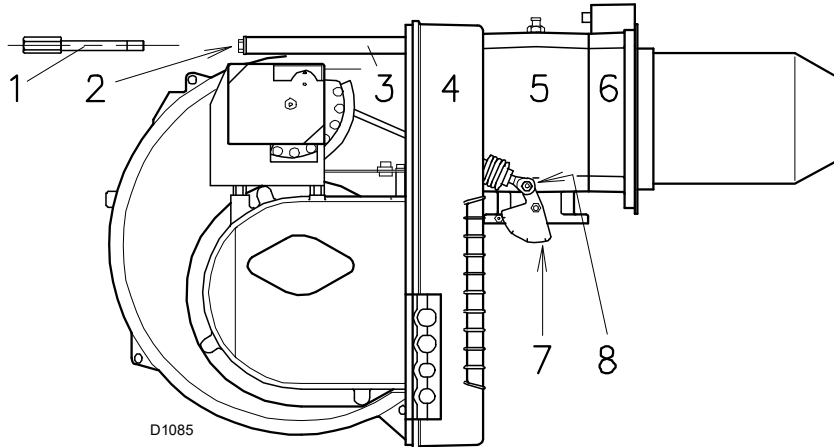

Fig. 15

### 5.10 Gas feeding



Explosion danger due to fuel leaks in the presence of a flammable source.

Precautions: avoid knocking, attrition, sparks and heat.

Make sure the fuel interception tap is closed before performing any operation on the burner.



**WARNING**

The fuel supply line must be installed by qualified personnel, in compliance with current standards and laws.

#### 5.10.1 Gas feeding line (Example) - Please refer to the gas train documentation for more information

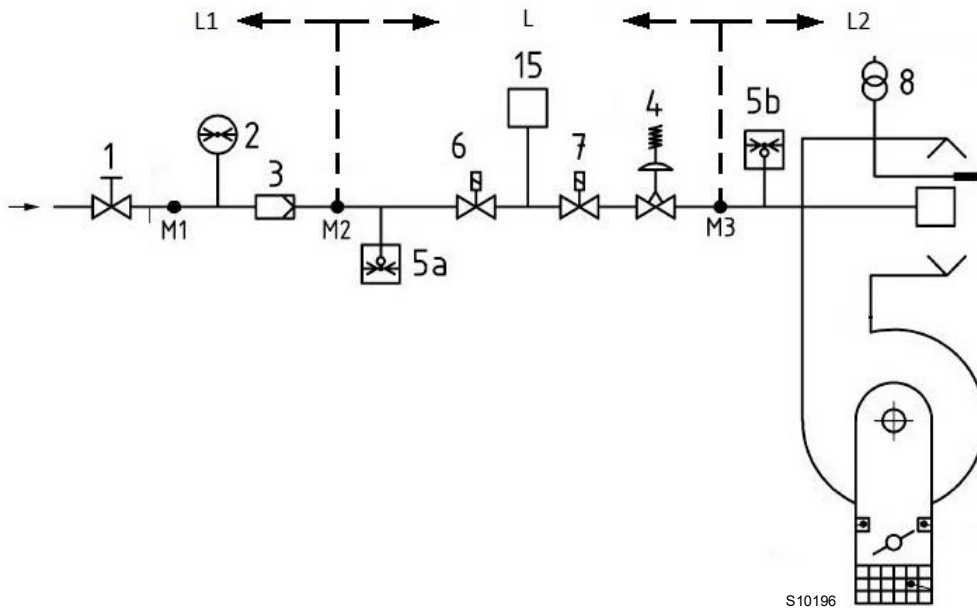

S10196

**Fig. 16**

Key (Fig. 16)

- 1 Manually operated shut-off valve
- 2 Pressure gauge
- 3 Filter
- 4 Governor
- 5a Low pressure protection device
- 5b Maximum gas pressure switch
- 6 1st safety shut-off device
- 7 2nd safety shut-off device
- 8 Ignition device
- 15 Valve leak detection control system
- L Gas train (supplied separately)
- L1 Responsibility of the installer
- L2 Burner
- M1 Pressure test point
- M2 Pressure test point
- M3 Pressure test point

**5.10.2 Gas train**

Approved according to standard EN 676 and provided separately from the burner.

**5.10.3 Gas train installation**



Disconnect the electrical power using the main switch.



Check that there are no gas leaks.



Pay attention when handling the train: danger of crushing of limbs.



Make sure that the gas train is properly installed by checking for any fuel leaks.



The operator must use the required equipment during installation.

The train can enter the burner from the right or left side, depending on which is the most convenient, see Fig. 17.

The gas train must be connected to the gas connection 1)(Fig. 17), using the flange 2), the gasket 3) and the screws 4) supplied with the burner.



The gas solenoids must be as close as possible to the burner to ensure that the gas reaches the combustion head within the safety time of 3s.

Ensure that the maximum pressure to the burner is within the calibration range of the pressure adjuster.

See the accompanying instructions for the adjustment of the gas train.

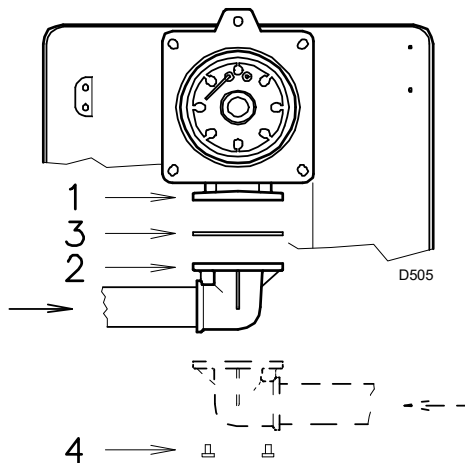

Fig. 17

**5.10.4 Gas pressure**

Tab. H indicates the pressure drops of the combustion head and gas butterfly valve, on the basis of the burner operating output.

kW	1 Δp (mbar)		2 Δp (mbar)	
	G 20	G 25	G 20	G 25
190	2.6	3.9	0.8	1.2
280	5.0	7.5	1.1	1.6
400	7.5	11.2	2.8	4.2
480	10.6	15.8	3.4	5.1
550	12.4	18.5	5.4	8.1

Tab. H



The heat output and gas pressure data in the head refer to operation with gas butterfly valve fully open (90°).

The values shown in Tab. H refer to:

- Natural gas G 20 NCV 9.45 kWh/Sm<sup>3</sup> (8.2 Mcal/Sm<sup>3</sup>)
- Natural gas G 25 NCV 8.13 kWh/Sm<sup>3</sup> (7.0 Mcal/Sm<sup>3</sup>)

Column 1

Combustion head pressure drop.

Gas pressure measured at test point 1)(Fig. 18), with:

- combustion chamber at 0 mbar
- burner working at maximum output

Column 2

Pressure loss at gas butterfly valve 2)(Fig. 18) with maximum opening: 90°.

To calculate the approximate output at which the burner operates:

- subtract the pressure in combustion chamber from the gas pressure measured at test point 1) (Fig. 18).
- Find, in Tab. H related to the burner concerned, the pressure value closest to the result of the subtraction.
- Read off the corresponding output on the left.

### Example with G 20 natural gas:

Maximum output operation

Gas pressure at test point 1)(Fig. 18) = 9.5 mbar

Pressure in combustion chamber = 2.0 mbar

$9.5 - 2.0 = 7.5$  mbar

A pressure of 7.5 mbar, column 1, corresponds in Tab. H to an output of 400 kW.

This value serves as a rough guide; the effective output must be measured at the gas meter.

To calculate the required gas pressure at test point 1) (Fig. 18), set the maximum modulating output required from the burner operation:

- find the nearest output value in Tab. H for the burner in question.
- read, on the right (column 1), the pressure at the test point 1) (Fig. 18).
- Add this value to the estimated pressure in combustion chamber.

### Example with G 20 natural gas:

Operating at the desired maximum output: 400 kW

Gas pressure at an output of 400 kW = 7.5 mbar

Pressure in combustion chamber = 2.0 mbar

$7.5 + 2.0 = 9.5$  mbar

pressure required at test point 1)(Fig. 18).

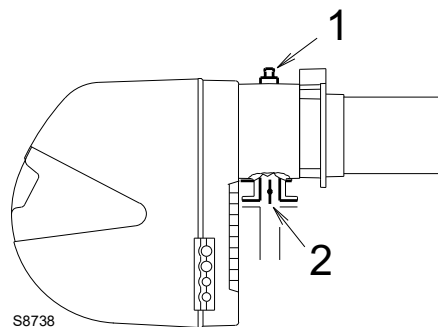

**Fig. 18**

**5.11 Electrical wiring**

**Notes on safety for the electrical wiring**



- The electrical wiring must be carried out with the electrical supply disconnected.
- Electrical wiring must be made in accordance with the regulations currently in force in the country of destination and by qualified personnel. Refer to the wiring diagrams.
- The manufacturer declines all responsibility for modifications or connections different from those shown in the wiring diagrams.
- Check that the electrical supply of the burner corresponds to that shown on the identification label and in this manual.
- The burner has been type-approved for intermittent operation (FS1). This means they should compulsorily be stopped at least once every 24 hours to enable the flame control to perform checks of its own start-up efficiency. Normally, burner stopping is guaranteed by the boiler's thermostat/pressure switch.
- If this is not the case, a time switch should be fitted in series to TL to stop the burner at least once every 24 hours. Refer to the wiring diagrams.
- The electrical safety of the device is obtained only when it is correctly connected to an efficient earthing system, made according to current standards. It is necessary to check this fundamental safety requirement. In the event of doubt, have the electrical system checked by qualified personnel. Do not use the gas tubes as an earthing system for electrical devices.
- The electrical system must be suitable for the maximum power absorption of the device, as indicated on the label and in the manual, checking in particular that the section of the cables is suitable for that level of power absorption.
- For the main power supply of the device from the electricity mains:
  - do not use adapters, multiple sockets or extensions;
  - make provisions for an omnipolar switch with a gap between the contacts of at least 3 mm (over-voltage category III), as required by current safety regulations.
- Do not touch the device with wet or damp body parts and/or in bare feet.
- Do not pull the electric cables.

Before carrying out any maintenance, cleaning or checking operations:



Turn off the burner's power supply using the main system switch.



Turn off the fuel interception tap.



Avoid condensate, ice and water leaks from forming.

If the cover is still present, remove it and proceed with the electrical wiring according to the wiring diagrams.

Use flexible cables according to EN 60 335-1 Regulations:

- if in a PVC sheath, use at least H05 VV-F;
- if in a rubber sheath, use at least H05 RR-F.

**5.11.1 Supply cables and external connections passage**

All the cables to be connected to the plugs 7)(Fig. 19) of the burner are passed through cable grommets to be inserted in the holes of the plate, left or right, after having unscrewed the screws 8), opened the plate at parts 9) and 10) and removed the thin diaphragm that closes the holes.

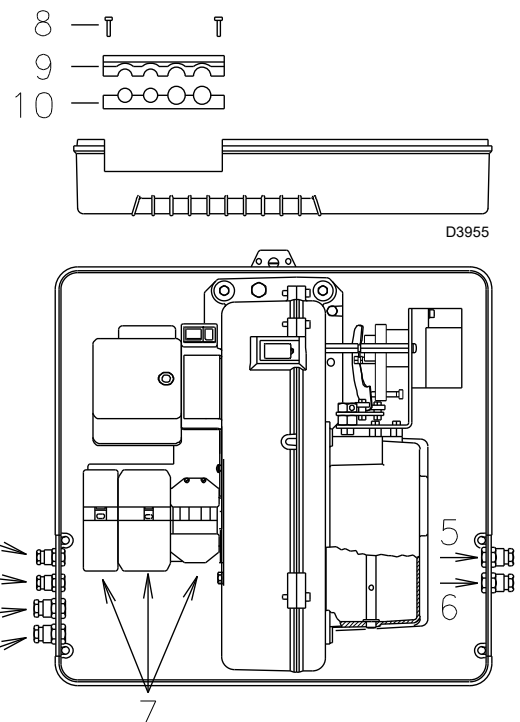

**Fig. 19**

The use of the cable grommets and the pre-blanked holes can be done in different manners; by way of example we indicate the following mode:

- |   |       |  |
|---|-------|--|
| 1 | Pg 11 | Single-phase power supply                        |
| 2 | Pg 11 | Gas valves                                       |
| 3 | Pg 9  | TL remote control                                |
| 4 | Pg 9  | TR remote control                                |
| 5 | Pg 11 | Gas pressure switch valve leak detection control |

### 5.11.2 Modulating operation

In the event the RWF output power regulator kit is connected or the converter 0...10V / 4...20mA, 3-point signal, the TR thermostat/pressure switch should be removed.

In addition, the function Q13 - Q14 of the regulator RWF can substitute the TL thermostat/pressure switch terminals T2 and T1 of the socket X7. In this case, the thermostat/pressure switch TL connected to the X7 must be removed.

On the contrary, if you want to maintain the thermostat/pressure switch TL, it must be adjusted so as not to interfere with the working of the regulator RWF.

**NOTE:**

The TR and TL remote controls are not necessary when the RWF is connected for modulating operation; their function is carried out by the regulator itself.



After carrying out maintenance, cleaning or checking operations, reassemble the cover and all the safety and protection devices of the burner.

**6 Start-up, calibration and operation of the burner**

**6.1 Notes on safety for the first start-up**



The first start-up of the burner must be carried out by qualified personnel, as indicated in this manual and in compliance with the standards and regulations of the laws in force.



Check the correct working of the adjustment, command and safety devices.



**Before igniting the burner, see the paragraph “Safety test - with gas feeding closed” on page 32.**

**6.2 Adjustments prior to ignition**

The adjustment of the combustion head, air and gas has already been described in the paragraph “Combustion head adjustment” on page 16.

In addition, the following adjustments must also be made:

- open the manual valves upline of the gas train.
- Adjust the minimum gas pressure switch to the start of the scale (Fig. 27).
- Adjust the air pressure switch to the start of the scale (Fig. 25).
- Purge the air from the gas line. We recommend using a plastic tube routed outside the building and to purge air until gas is smelt.
- Fit a U-type pressure gauge (Fig. 20) to the gas pressure test point on the pipe coupling. Used to roughly calculate MAX burner output using the tables Tab. H on page 19.
- Connect two lamps or testers parallel to the two gas line solenoids VR and VS in order to check the exact moment at which voltage is supplied. This operation is unnecessary if each of the two solenoids is equipped with a pilot light that signals voltage passing through.



Before starting up the burner, it is good practice to adjust the gas train so that ignition takes place in conditions of maximum safety, i.e. with gas delivery at the minimum.

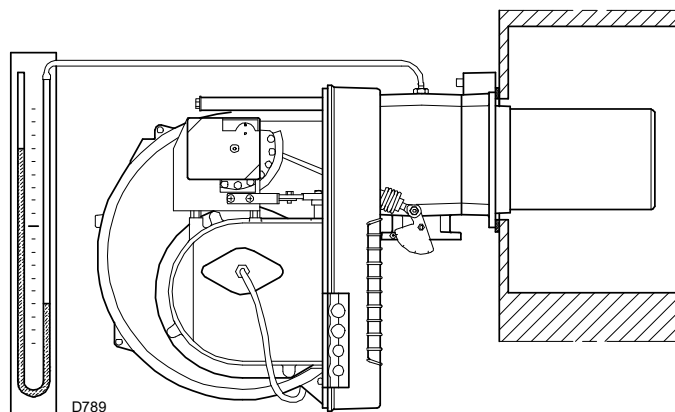

**Fig. 20**

**6.3 Servomotor**

The servomotor (Fig. 21) provides simultaneous adjustment for the air damper, by means of the variable profile cam and the gas butterfly valve.

The angle of rotation of the servomotor is equal to the angle on the graduated sector controlling the gas butterfly valve.

The servomotor rotates 90° in 24 s.



Do not alter the factory setting for the 4 cams; just check that they are as indicated below.

**Cam I: 90°**

Limits rotation toward maximum position.

When the burner is at MAX output, the gas butterfly valve must be fully open: 90°.

**Cam II: 0°**

Limits rotation toward minimum position.

When the burner is shut down, the air damper and gas butterfly valve must be closed: 0°.

**Cam III: 20°**

Adjusts the ignition position and the MIN output.

**Cam IV:** integrated to cam III.

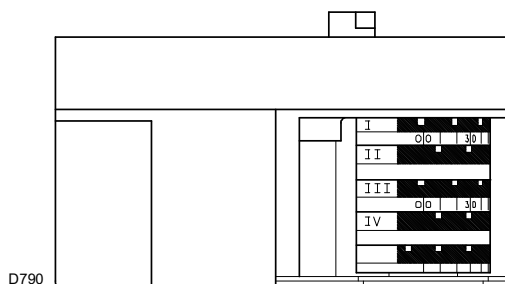
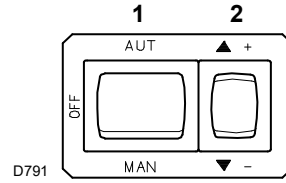

**Fig. 21**

**6.4 Burner start-up**

Turn off the remote controls and set the switch 1)(Fig. 22) to "MAN".

As soon as the burner starts, check the direction of rotation of the fan impeller, looking through the flame inspection window 18) (Fig. 6 on page 12).



**Fig. 22**



Make sure that the lights or testers connected to the solenoids, or the pilot lights on the solenoids themselves, indicate that no voltage is present.

If voltage is present, stop the burner immediately and check the electrical connections.

**6.5 Burner ignition**

Having completed the checks indicated in the previous heading, ignition of the burner should be achieved.

If the motor starts but the flame does not appear and the flame control goes into lockout, reset and wait for a new ignition attempt.

If ignition is still not achieved, it may be that gas is not reaching the combustion head within the safety time period of 3 seconds.

In this case increase gas ignition delivery. The arrival of gas at the pipe coupling is indicated by the U-type pressure gauge (Fig. 20 on page 23).

Once the burner has fired, now proceed with global calibration operations.

**6.6 Burner adjustment**

The optimum adjustment of the burner requires an analysis of flue gases at the boiler outlet.

Adjust in sequence:

- 1 Output upon ignition
- 2 Maximum output
- 3 Minimum output
- 4 Intermediate outputs between the two
- 5 Air pressure switch
- 6 Minimum gas pressure switch

**6.6.1 Output upon ignition**



For safety purposes and correct product operation, the ignition output, if it is adjustable, must be carried out by authorized personnel and in compliance with the standards and regulations of the laws in force.

**6.6.2 Maximum output**

The MAX output must be set within the firing rate (Fig. 2 on page 9).

In the above instructions we left the burner running at the MIN output.

Now press the "increase output" button 2)(Fig. 22), and keep it pressed until the servomotor has opened the air damper and the gas butterfly valve to 90°.

**Adjustment of gas delivery**

Measure the gas delivery on the gas meter.

A rough indication can be obtained from Tab. H on page 19, just read the gas pressure on the pressure gauge see Fig. 20 on page 23, and follow the indication given in Tab. H on page 19.

- If delivery needs to be reduced, diminish outlet gas pressure; if it is already very low, slightly close the VR adjustment valve.
- If delivery needs to be increased, increase the adjuster outlet gas pressure.

**Air adjustment**

Progressively adjust the end profile of cam 4)(Fig. 23) by turning the screws of the cam that appear inside the opening 6)(Fig. 23).

- Turn the screws clockwise to increase air delivery
- Turn the screws anticlockwise to reduce air delivery

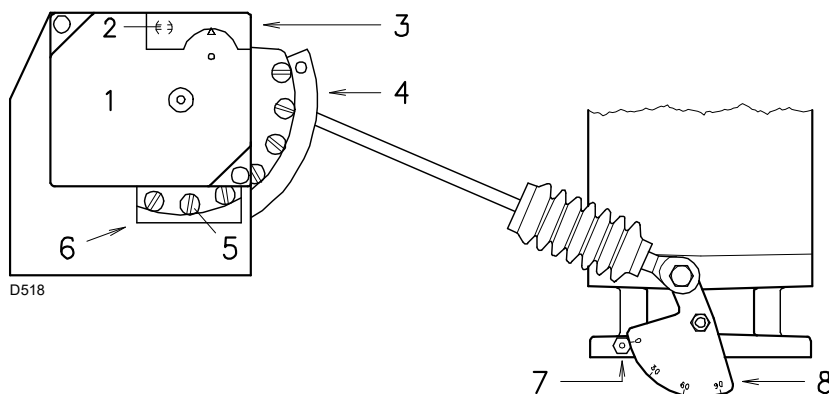

**Fig. 23**

Key (Fig. 23)

- 1 Servomotor
- 2 ⊖ Cam 4 engaged/ ⊕ disengaged
- 3 Cam cover
- 4 Variable profile cam
- 5 Screws for adjusting the adjustable profile
- 6 Opening for access to screws 5
- 7 Index for graduated sector 8
- 8 Graduated sector for gas butterfly valve

**6.6.3 Minimum output**

The MIN output must be set within the firing rate (Fig. 2 on page 9).

Press the “reduce output” button 2)(Fig. 22 on page 24) and keep it pressed until the servomotor has closed the air damper and the gas butterfly valve is at 20° (adjustment made in the factory).

**Adjustment of gas delivery**

Measure the gas delivery on the gas meter.

- If it is necessary to reduce it, slightly decrease the angle of cam III (Fig. 24) with small, regular movements, i.e. bring it from an angle of 20° to 18° - 16°....
- If you need to increase it, lightly press the “increase output” button 2)(Fig. 22 on page 24) (open the gas butterfly valve by 10-15°), and increase angle of cam III (Fig. 24) with a series of small movements, i.e. move from angle 20° to 22° - 24°....
- Now press the “power reduction” button until the servomotor returns to the minimum opening position, and measure the gas delivery.

**NOTE:**

The servomotor follows the adjustment of cam III only when the angle of the cam is reduced.

If it is necessary to increase the angle of the cam, you must first increase the angle of the servomotor by means of the “output increase” key, then increase the angle of cam III, and finally bring the servomotor to the position of MIN output, with the “output reduction” key.

To adjust cam III, remove the snap action cover 1)(Fig. 24), remove the relative key 2) from inside and insert it into the notch of cam III.

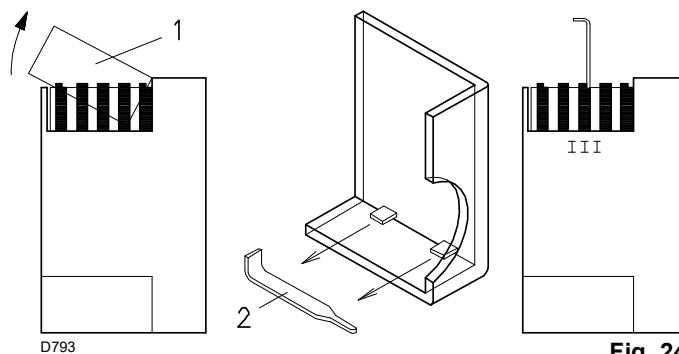

**Fig. 24**

**Air adjustment**

Progressively adjust the beginning profile of cam 4)(Fig. 23) by turning the screws of the cam that appear inside the opening 6)(Fig. 23).

It is preferable not to turn the first screw since this is used to set the air damper to its fully closed position.

**6.6.4 Intermediate outputs**

**Adjustment of gas delivery**

No adjustment of gas delivery is required.

**Air adjustment**

Lightly press the "increase output" button 2)(Fig. 22 on page 24) so that a new screw 5)(Fig. 23) appears inside the opening 6)(Fig. 23), adjust it until optimal combustion is obtained.

Proceed in the same way with the other screws.



**WARNING**

Take care that the cam profile variation is progressive.

Switch off the burner using the switch 1)(Fig. 22 on page 24), position OFF, release the variable profile cam from the servomotor putting the notch 2)(Fig. 23) in the vertical position.

Check that the movement is fluid and free of jamming by turning the cam backwards and forwards by hand a few times.



**WARNING**

As far as is possible, try not to move those screws at the ends of the cam that were previously adjusted for the opening of the air damper to MAX and MIN output.

**NOTE:**

Once you have finished adjusting outputs MAX - MIN - INTERMEDIATE, check ignition once again: noise emission at this stage must be identical to the following stage of operation. If you notice any sign of pulsations, reduce the ignition stage delivery.

**6.7 Final adjustment of the pressure switches**

**6.7.1 Air pressure switch**

The air pressure switch (Fig. 25) is connected as in 2)(Fig. 26). It can be connected in differential mode, see 1) (Fig. 26), i.e. it is under pressure either by the depression or by pressure generated by the fan. In this way the burner can operate even in combustion chambers in depression and with high modulation ratios: MIN / MAX outputs of up to 1/6.

In this case the air pressure switch needs no adjustment and its function is limited to controlling fan operation.

Warning: The use of the air pressure switch with differential operation is allowed only in industrial applications and where rules enable the air pressure switch to control only fan operation without any reference to CO limit.

Air pressure switch connected as in 2)(Fig. 26):

The air pressure switch is set after all other adjustments have been made. Begin with the switch at the start of the scale.

With the burner operating at MIN output, increase adjustment pressure by slowly turning the relative knob clockwise until the burner locks out.

Then turn the knob anti-clockwise by about 20% of the set point and repeat burner starting to ensure it is correct.

If the burner locks out again, turn the knob anticlockwise a little bit more.

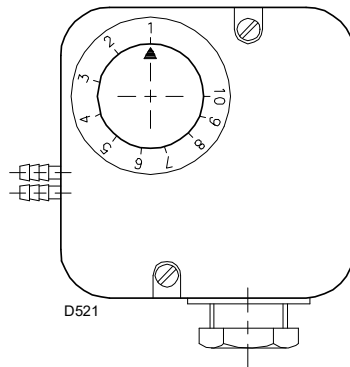

**Fig. 25**

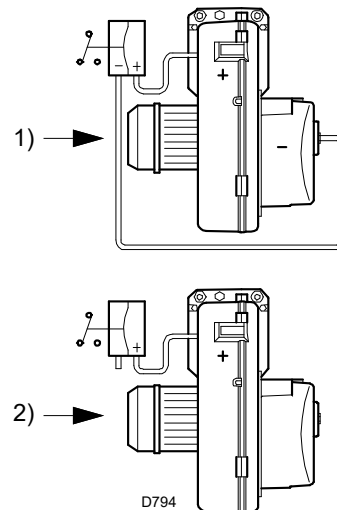

**Fig. 26**



**WARNING**

In conformity with current standards, the air pressure switch must prevent the CO in the flue gases exceeding 1% (10,000 ppm). To check this, insert a combustion analyser into the chimney, slowly close the fan suction inlet (for example with cardboard) and check that the burner locks out, before the CO in the fumes exceeds 1%.



**WARNING**

Connecting the air pressure switch in differential mode, the burner will no longer be certified according to the EN 676 standard.

### 6.7.2 Minimum gas pressure switch

The purpose of the minimum gas pressure switch is to prevent the burner from operating in an unsuitable way due to too low gas pressure.

Adjust the minimum gas pressure switch (Fig. 27) after having adjusted the burner, the gas valves and the gas train stabiliser. With the burner operating at maximum output:

- install a pressure gauge downstream of the gas train stabiliser (for example at the gas pressure test point on the burner combustion head);
- choke slowly the manual gas cock until the pressure gauge detects a decrease in the pressure read of about 0.1 kPa (1 mbar). In this phase, verify the CO value which must always be less than 100 mg/kWh (93 ppm).
- Increase the adjustment of the gas pressure switch until it intervenes, causing the burner shutdown;
- remove the pressure gauge and close the cock of the gas pressure test point used for the measurement;
- open completely the manual gas cock.

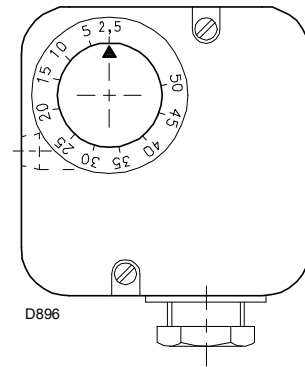

Fig. 27



WARNING

1 kPa = 10 mbar

**6.8 Burner operation**

**6.8.1 Burner start-up**

- 0s: TL thermostat/pressure switch closes.
- 2s: Start of flame control programme. Servomotor starts: turn 90° to the left, i.e. until the contact on cam I intervenes (Fig. 21 on page 23).
- 26s: The air damper arrives to the MAX. output position. Fan motor starts up. Start of the pre-purging phase.
- 57s: the servomotor rotates towards the right, as far as the angle set on cam III (Fig. 21 on page 23) for the MIN output.
- 77s: The air damper and gas butterfly valve assume the MIN output position (with cam III)(Fig. 21 on page 23) at 15°.
- 92s: Ignition electrode strikes a spark. The safety valve VS opens, along with the adjustment valve VR, quick opening. The flame is ignited at a low output level, point A. Delivery is then progressively increased, with the valve VR opening slowly up to MIN. output, point B.
- 94s: The spark goes out.
- 118s: The starting cycle comes to an end.

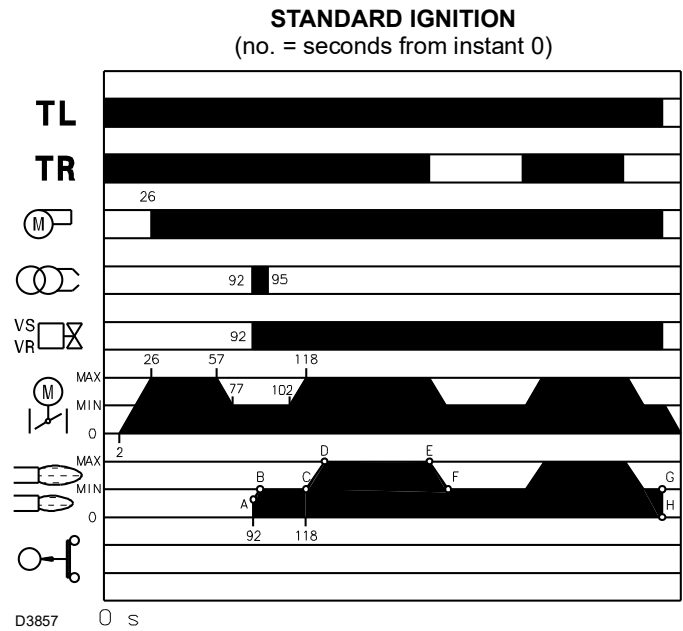

**Fig. 28**

**6.8.2 Operation**

**Burner without modulating operation kit**

Once the start-up cycle is completed, the servomotor command moves on to the TR thermostat/pressure switch that controls the pressure or the temperature in the boiler, point C.

(The flame control still continues to check the presence of the flame and the correct position of the air and gas pressure switches).

- If the temperature or the pressure is low, the reason why the thermostat/pressure switch TR is in the output request position, the burner progressively increases the output up to the MAX value (section C-D).
- If, then, the temperature or the pressure increases up to the TR switching, the burner gradually decreases the output down to the MIN value, (section E-F). The sequence repeats endlessly.
- The burner locks out when the heat request is less than the heat supplied by the burner at MIN output, (section G-H). The TL thermostat/pressure switch opens, and the servomotor returns to angle 0°. The air damper closes completely to reduce heat losses to a minimum.

**Burner with modulating operation kit**

See manual enclosed with the adjuster.

**6.8.3 Ignition failure**

If the burner does not switch on, it goes into lockout within 3s of the gas valve opening.

**6.8.4 Burner flame goes out during operation**

If the flame should accidentally go out during operation, the burner will lock out within 1s.

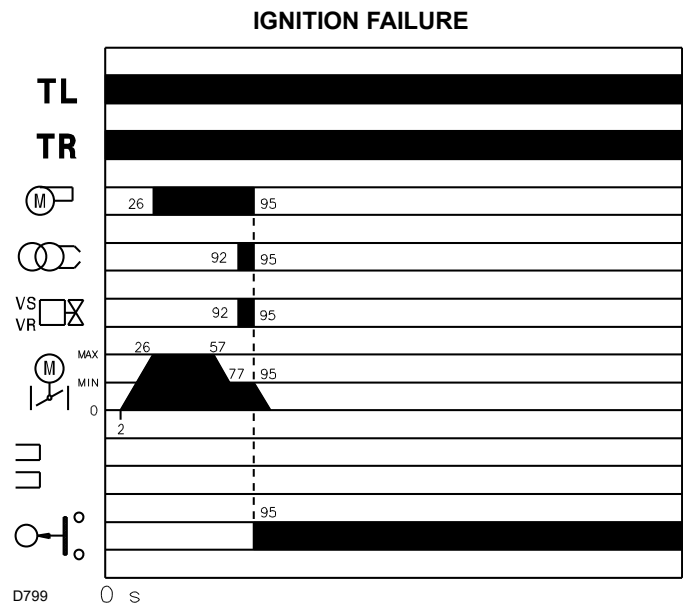

**Fig. 29**



In the event the burner stops, in order to prevent any damage to the installation, do not unblock the burner more than twice in a row.

If the burner locks out for a third time, contact the customer service.



In the event there are further lockouts or faults with the burner, the maintenance interventions must only be carried out by qualified, authorised personnel, in accordance with the contents of this manual and in compliance with the standards and regulations of current laws.

**6.9 Burner start-up cycle diagnostics**

During the start-up programme, the indications are set out in Tab. I:

COLOUR CODE TABLE	
Sequences	Colour code
Pre-purging	●●●●●●●●●●
Ignition phase	●○●○●○●○●○
Operation, flame OK	□□□□□□□□□□
Operation with weak flame signal	□○□○□○□○□○
Electrical supply below ~ 170V	●▲●▲●▲●▲●▲
Lockout	▲▲▲▲▲▲▲▲▲▲
Extraneous light	▲□▲□▲□▲□▲□
Key:	○ Off      ● Yellow      □ Green      ▲ Red

Tab. I

**6.10 Resetting of flame control and diagnostics use**

The flame control features a diagnostics function through which any causes of malfunctioning are easily identified (indicator: **RED LED**).

To use this function, you must wait at least 10 seconds once it has entered the safety condition (**lockout**), and then press the reset button.

The flame control generates a sequence of pulses (1 second apart), which is repeated at constant 3-second intervals.

Once you have seen how many times the light blinks and identified the possible cause, the system must be reset by holding the button down for 1 - 3 seconds.

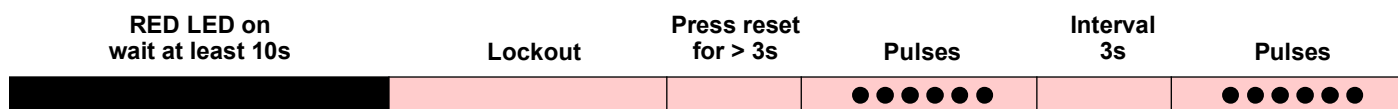

The methods that can be used to reset the flame control and use diagnostics are given below.

**6.10.1 Flame control reset**

- To carry out the flame control reset, proceed as follows:
- Hold the button down for between 1 and 3 seconds. The burner restarts after a 2-second pause once the button is released. If the burner does not restart, you must make sure the limit thermostat is closed.

**6.10.2 Visual diagnostics**

- Indicates the type of burner malfunction causing lockout.
- To view diagnostics, proceed as follows:
- Hold the button down for more than 3 seconds once the red LED (burner lockout) remains steadily lit. A yellow light blink to tell you the operation is done.
  - Release the button once the light has blinked. The number of blinks indicates the reason for the malfunctioning (refer to the coding in Tab. N).

**6.10.3 Software diagnostics**

Gives an analysis of the life of the burner, through optical connections with a PC showing the working hours, number and types of lockout, flame control serial number etc...

- To view diagnostics, proceed as follows:
- Hold the button down for more than 3 seconds once the red LED (burner lockout) remains steadily lit. A yellow light blink to tell you the operation is done.
  - Release the button for 1 second and then press again for over 3 seconds until the yellow light blinks again.
  - Once the button is released, the red LED will flash intermittently with a higher frequency: only now can the optical link be activated.

Once the operations are done, the flame control's initial status must be restored using the resetting procedure described above.

Pressing the button	Flame control status
From 1 to 3 seconds	Reset of the flame control without visualisation of the visual diagnostics.
More than 3 seconds	Visual diagnostics of the lockout condition: (LED blinks at 1-second intervals).
More than 3 seconds starting from the condition of visual diagnostics	Diagnostic software using an optical interface and PC (possibility of displaying the hours the machine has been running, faults, etc...)

The sequence of led pulses issued by the flame control identifies the possible types of malfunction, which are listed in the table Tab. N.

**6.11 Normal operation / flame detection time**

The flame control has a further function to guarantee the correct burner operation (signal: **GREEN LED** permanently on).

To use this function, wait at least ten seconds from the burner ignition and then press the flame control button for a minimum of 3 seconds.

After releasing the button, the GREEN LED starts flashing, as shown below.

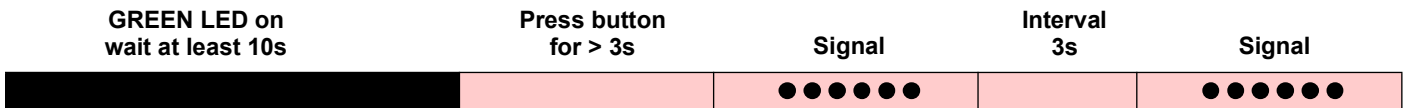

The pulses of the LED constitute a signal spaced by approximately 3 seconds.

The number of pulses will identify the DETECTION TIME of the probe since the opening of gas valves, according to: Tab. J.

Signal	Flame detection time
1 blink ●	0.4 s
2 blinks ● ●	0.8 s
6 blinks ● ● ● ● ● ●	2.8 s

Tab. J

This is updated in every burner start-up.

Once read, the burner repeats the start-up cycle by briefly pressing the flame control button.



If the result is > 2 s, ignition will be retarded. Check the adjustment of the hydraulic brake of the gas valve, the air damper and the combustion head adjustment.

**6.12 Flame presence check**

The burner is fitted with an ionisation system to check that a flame is present. The minimum current for flame control operation is 2 µA.

The burner provides a much higher current, so controls are not normally required.

However, if it is necessary to measure the ionisation current, disconnect the plug-socket 23 (Fig. 6 on page 12) on the ionisation probe cable and insert a direct current microammeter with a base scale of 100 µA.

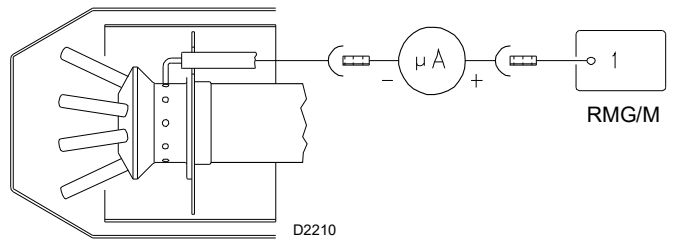



Fig. 30



Carefully check the polarities!

**6.13 Final checks (with burner operating)**

<ul style="list-style-type: none"> <li>➤ Disconnect a wire of the minimum gas pressure switch</li> <li>➤ Open the thermostat/pressure switch TL</li> <li>➤ Open the thermostat/pressure switch TS</li> </ul>		<p>The burner must stop</p>
<ul style="list-style-type: none"> <li>➤ Disconnect the common wire P of the air pressure switch</li> <li>➤ Disconnect the wire of the ionisation probe</li> </ul>		<p>The burner must stop in lockout</p>

**Tab. K**



Make sure that the mechanical locking systems on the various adjustment devices are fully tightened.

**7 Maintenance**

**7.1 Notes on safety for the maintenance**

The periodic maintenance is essential for the good operation, safety, yield and duration of the burner.

It allows you to reduce consumption and polluting emissions and to keep the product in a reliable state over time.



The maintenance interventions and the calibration of the burner must only be carried out by qualified, authorised personnel, in accordance with the contents of this manual and in compliance with the standards and regulations of current laws.

Before carrying out any maintenance, cleaning or checking operations:



Turn off the burner's power supply using the main system switch.



Turn off the fuel interception tap.



Wait for the components in contact with heat sources to cool down completely.

**7.2 Maintenance programme**

**7.2.1 Maintenance frequency**



The gas combustion system should be checked at least once a year by a representative of the manufacturer or another specialised technician.

**7.2.2 Safety test - with gas feeding closed**

For its safe commissioning it is very important to make sure that the electrical wiring has been carried out correctly between the gas valves and the burner.

To this end, after checking that the connections have been made in conformity with the burner's wiring diagram, a starting cycle should be carried out with the gas tap closed (dry test).

- 1 The manual gas valve should be closed with the locking/releasing device ("lock-out / tag out" procedure).
- 2 Make sure the limit electric contacts of the burner close
- 3 Make sure the contact of the minimum gas pressure switch closes
- 4 Proceed with a tentative start up of the burner.

The starting cycle should occur with the following phases:

- Starting the fan motor for pre-purging
- Carrying out the gas valve leak detection control, if applicable
- Completing the pre-purging
- Reaching the ignition point
- Power supply of the ignition transformer
- Power supply the gas valves.

Since the gas is closed, the burner will not be able to start and its flame control will stop or go into a safety lockout.

The effective supplying of the gas valves can be checked with the insertion of a tester; some valves are fitted with light signals (or closure/opening position indicators) that are activated when the electrical supply arrives.



**IF THE ELECTRICAL SUPPLY OF THE GAS VALVES OCCURS AT AN UNEXPECTED MOMENT, DO NOT OPEN THE MANUAL VALVE, DISCONNECT THE ELECTRICAL SUPPLY, CHECK THE WIRING; CORRECT THE ERRORS AND CARRY OUT THE ENTIRE TEST AGAIN.**

**7.2.3 Checking and cleaning**



The operator must use the required equipment during maintenance.

**Combustion**

The optimum calibration of the burner requires an analysis of the flue gases. Significant differences with respect to the previous measurements indicate the points where most care should be exercised during maintenance.

**Combustion head**

Open the burner and make sure that all components of the combustion head are in good condition, not deformed by the high temperatures, free of impurities from the surroundings, and that the relative materials are not corroded and that they are correctly positioned.

Check the gas outlet holes for the ignition phase (in the distributor of the combustion head) are free of impurities or rust. If in doubt, disassemble the elbow.

**Flame inspection window**

Periodically clean the glass of the flame inspection window (Fig. 31).

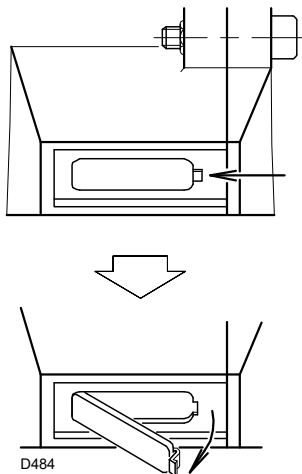

Fig. 31

**Gas distributor**

Periodically check that the combustion head is clean. A tool has to be used, as shown in Fig. 32, to make sure that the holes for the gas to pass through are free and without any impurities.

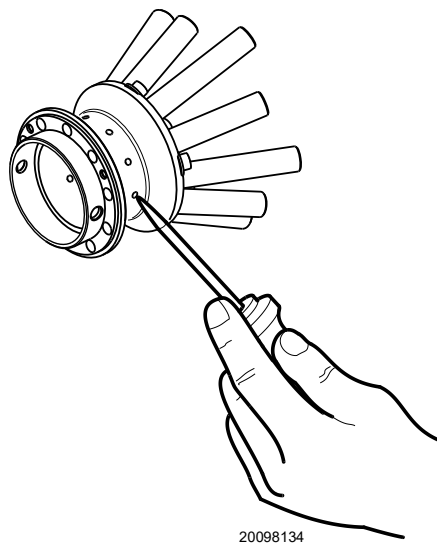

Fig. 32

**Servomotor**

Release the cam 4)(Fig. 23 on page 25) from the servomotor, turning the notch 2) 90° (Fig. 23 on page 25) and manually checking that its rotation, backwards and forwards, is smooth. Connect the cam 4) again.

**Burner**

Check for excess wear or loose screws in the mechanisms controlling the air damper and the gas butterfly valve. Also make sure that the screws securing the electrical leads in the terminal board are fully tightened.

Clean the outside of the burner, taking special care with the articulated couplings and the cam 4)(Fig. 23 on page 25).

**Fan**

Check to make sure that no dust has accumulated inside the fan or on its impellers, as this condition will cause a reduction in the air flow rate and provoke polluting combustion.

**Boiler**

Clean the boiler as indicated in its accompanying instructions in order to maintain all the original combustion characteristics intact, especially the flue gas temperature and pressure in combustion chamber.

**Gas leaks**

Make sure that there are no gas leaks on the pipe between the gas meter and the burner.

**Gas filter**

Change the gas filter when it is dirty.

**Combustion**

In case the combustion values found at the beginning of the intervention do not respect the standards in force or, in any case, do not correspond to a proper combustion, contact the Technical Assistance Service in order to carry out the necessary adjustments.

EN 676		Air excess		CO
		Max. output. $\lambda \leq 1.2$	Max. output. $\lambda \leq 1.3$	
GAS	Theoretical max CO <sub>2</sub> 0% O <sub>2</sub>	CO <sub>2</sub> % Calibration		mg/kWh
		$\lambda = 1.2$	$\lambda = 1.3$	
G 20	11.7	9.7	9	≤ 100
G 25	11.5	9.5	8.8	≤ 100
G 30	14.0	11.6	10.7	≤ 100
G 31	13.7	11.4	10.5	≤ 100

Tab. L

**7.2.4 Safety components**

The safety components should be replaced at the end of their life cycle indicated in the following table.

The specified life cycles do not refer to the warranty terms indicated in the delivery or payment conditions.

Safety component	Life cycle
Flame control	10 years or 250,000 operation cycles
Flame sensor	10 years or 250,000 operation cycles
Gas valves (solenoid)	10 years or 250,000 operation cycles
Pressure switches	10 years or 250,000 operation cycles
Pressure adjuster	15 years
Servomotor (electronic cam) (if present)	10 years or 250,000 operation cycles
Oil valve (solenoid) (if present)	10 years or 250,000 operation cycles
Oil regulator (if present)	10 years or 250,000 operation cycles
Oil pipes/ couplings (metallic) (if present)	10 years
Fan impeller	10 years or 500,000 start-ups

Tab. M

### 7.3 Opening the burner



Turn off the burner's power supply using the main system switch.



Turn off the fuel interception tap.



Wait for the components in contact with heat sources to cool down completely.

- Remove the screw 1)(Fig. 33) and take away the cover 2).
- Disengage the articulated coupling 3) from the graduated sector 4).
- Remove screw 5), the split pin 9) and pull the burner back by about 100 mm on the slide bars 6).
- Disconnect the probe and electrode leads and then pull the burner fully back.
- Turn it as indicated in the diagram, and insert the split pin 9) into the hole of one of the two guides so that the burner remains in that position.

Now extract the gas distributor 7) after having removed the screw 8).

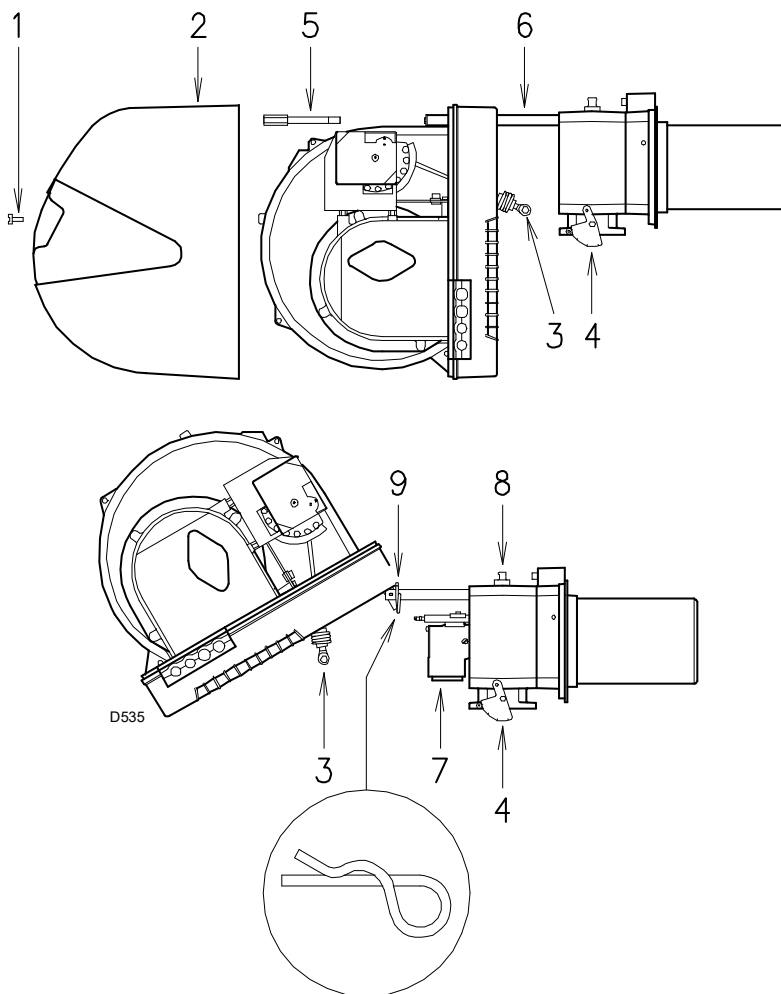

Fig. 33

### 7.4 Closing the burner

- Remove the split pin 9)(Fig. 33) and push the burner until it is approx. 100 mm from the pipe coupling.
- Reconnect the cables and slide in the burner until it comes to a stop.
- Replace the screws 5) and split pin 9) and carefully pull the probe and electrode cables outwards until they are slightly taut.
- Reconnect the articulated coupling 3) to the graduated sector 4).



After carrying out maintenance, cleaning or checking operations, reassemble the cover and all the safety and protection devices of the burner.

**8** Faults - Probable causes - Solutions



In the event the burner stops, in order to prevent any damage to the installation, do not unblock the burner more than twice in a row.

If the burner locks out for a third time, contact the customer service.



In the event there are further lockouts or faults with the burner, the maintenance interventions must only be carried out by qualified, authorised personnel, in accordance with the contents of this manual and in compliance with the standards and regulations of current laws.

Signal	Problem	Possible cause	Recommended remedy
2 blinks ● ●	Once the pre-purging phase and safety time have passed, the burner goes into lockout without the appearance of the flame.	The operation solenoid lets little gas through	Increase
		One of the two solenoid valves does not open	Replace
		Gas pressure too low	Increase pressure at governor
		Ignition electrode incorrectly adjusted	Adjust it
		Electrode grounded due to broken insulation	Replace
		High voltage cable defective	Replace
		High voltage cable deformed by high temperature	Replace and protect
		Ignition transformer defective	Replace
		Incorrect valve or transformer electrical wiring	Check
		Defective flame control	Replace
		A closed valve upline the gas train	Open
		Air in pipework	Bleed air
Gas valves unconnected or with interrupted coil	Check connections or replace coil		
3 blinks ● ● ●	The burner does not come on and the lockout appears	Air pressure switch in operating position	Adjust or replace
	The burner starts and then goes into lockout	Air pressure switch does not switch owing to lack of air pressure	
		Air pressure switch poorly adjusted	Adjust or replace
		Pressure switch pressure point pipe blocked	Clean
		Poorly adjusted head	Adjust
		High pressure in the furnace	Connect air pressure switch to fan suction line
	Lockout during pre-purging phase	Defective motor control contactor (only three-phase version)	Replace
Defective electrical motor		Replace	
Motor lockout (only three-phase version)		Replace	
4 blinks ● ● ● ●	The burner switches on, but then stops in lockout	Flame simulation	Replace the flame control
	Lockout when burner stops	Permanent flame in the combustion head or flame simulation	Eliminate persistence of flame or replace flame control
6 blinks ● ● ● ● ● ●	The burner switches on, but then stops in lockout	Defective or incorrectly adjusted servomotor	Adjust or replace
7 blinks ● ● ● ● ● ● ●	The burner goes into lockout immediately following the appearance of the flame	The operation solenoid lets little gas through	Increase
		Ionisation probe incorrectly adjusted	Adjust
		Insufficient ionisation (less than 5 A)	Check probe position
		Earth probe	Withdraw or replace cable
		Burner poorly earthed	Check earthing
		Phase and neutral connections inverted	Invert them
		Defective flame detection circuit	Replace the flame control
	Burner locks out when shifting from minimum to maximum output and vice versa	Too much air or too little gas	Adjust air and gas
	Burner goes into lockout during operation	Probe or ionisation cable grounded	Replace worn parts

Signal	Problem	Possible cause	Recommended remedy
10 blinks ●●●●●● ●●●●●●	The burner does not come on and the lock-out appears	Incorrect electrical wiring	Check
	The burner goes into lockout	Defective flame control	Replace
		Presence of electromagnetic disturbances in the thermostat lines	Filter or eliminate
		Presence of electromagnetic disturbance	Use the radio disturbance protection kit
No blink	The burner does not start	No electricity supply	Close all switches - Check connections
		A limiter or safety control device is open	Adjust or replace
		Line fuse blocked	Replace
		Defective flame control	Replace
		No gas supply	Open the manual valves between contactor and train
		Mains gas pressure insufficient	Contact your gas company
		Minimum gas pressure switch fails to close	Adjust or replace
		Servomotor fails to move to min. ignition position	Replace
	The burner continues to repeat the start-up cycle, without lockout	The gas pressure in the gas mains lies very close to the value to which the gas pressure switch has been set. The sudden drop in pressure after valve opening causes temporary opening of the pressure switch itself, the valve immediately closes and the burner comes to a halt. Pressure increases again, the pressure switch closes again and the ignition cycle is repeated. The sequence repeats endlessly.	Reduce the minimum gas pressure switch intervention pressure. Replace the gas filter cartridge.
	Ignition with pulsations	Poorly adjusted head	Adjust
		Ignition electrode incorrectly adjusted	Adjust it
		Incorrectly adjusted fan air damper: too much air	Adjust
		Output during ignition phase is too high	Reduce
	Burner does not reach maximum output	Remote control device TR fails to close	Adjust or replace
Defective flame control		Replace	
	Defective servomotor	Replace	
Burner stops with air damper open	Defective servomotor	Replace	

**Tab. N**

**A Appendix - Accessories****Long head kit**

Burner	Standard head length (mm)	Long head length (mm)	Code
RS 45/M BLU	229	354	3010240

**Spacer kit**

Burner	Thickness (mm)	Code
RS 45/M BLU	100	3010095

**Continuous purging kit**

Burner	Code
RS 45/M BLU	3010094

**Soundproofing box kit**

Burner	Type	dB(A)	Code
RS 45/M BLU	C1/3	10	3010403

**Output power regulator kit for modulating operation**

Burner	Probe	Adjustment field	Code
RS 45/M BLU	PT 100 temperature	- 100 + 500°C	3010110
	Pressure 4 ÷ 20 mA	0 ÷ 2.5 bar	3010213
	Pressure 4 ÷ 20 mA	0 ÷ 16 bar	3010214

Burner	Output regulator	Code
RS 45/M BLU	RWF50	20082208
	RWF55	20099657

Burner	Signal converter	Code
RS 45/M BLU	0/2 - 10V 0/4 - 20mA	3010390

Burner	Potentiometer	Code
RS 45/M BLU	1000 Ω	3010109

**Differential circuit breaker kit**

Burner	Code
RS 45/M BLU	3010329

**PC interface kit**

Burner	Code
RS 45/M BLU	3002719

**Radio disturbance protection kit**

---

Burner	Code
RS 45/M BLU	3010386

**LPG kit**

---

Burner	Code
RS 45/M BLU	3010432

**Gas trains in compliance with EN 676**

---

Please refer to manual.

**B Appendix - Electrical panel layout**

<b>1</b>	<b>Index of layouts</b>
<b>2</b>	Indication of references
<b>3</b>	RMG/M... operational layout
<b>4</b>	Operational layout
<b>5</b>	Electrical wiring that the installer is responsible for
<b>6</b>	RWF50 kit electrical wiring... external

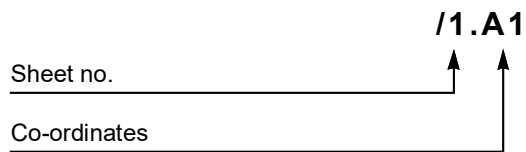
**2 Indication of references**

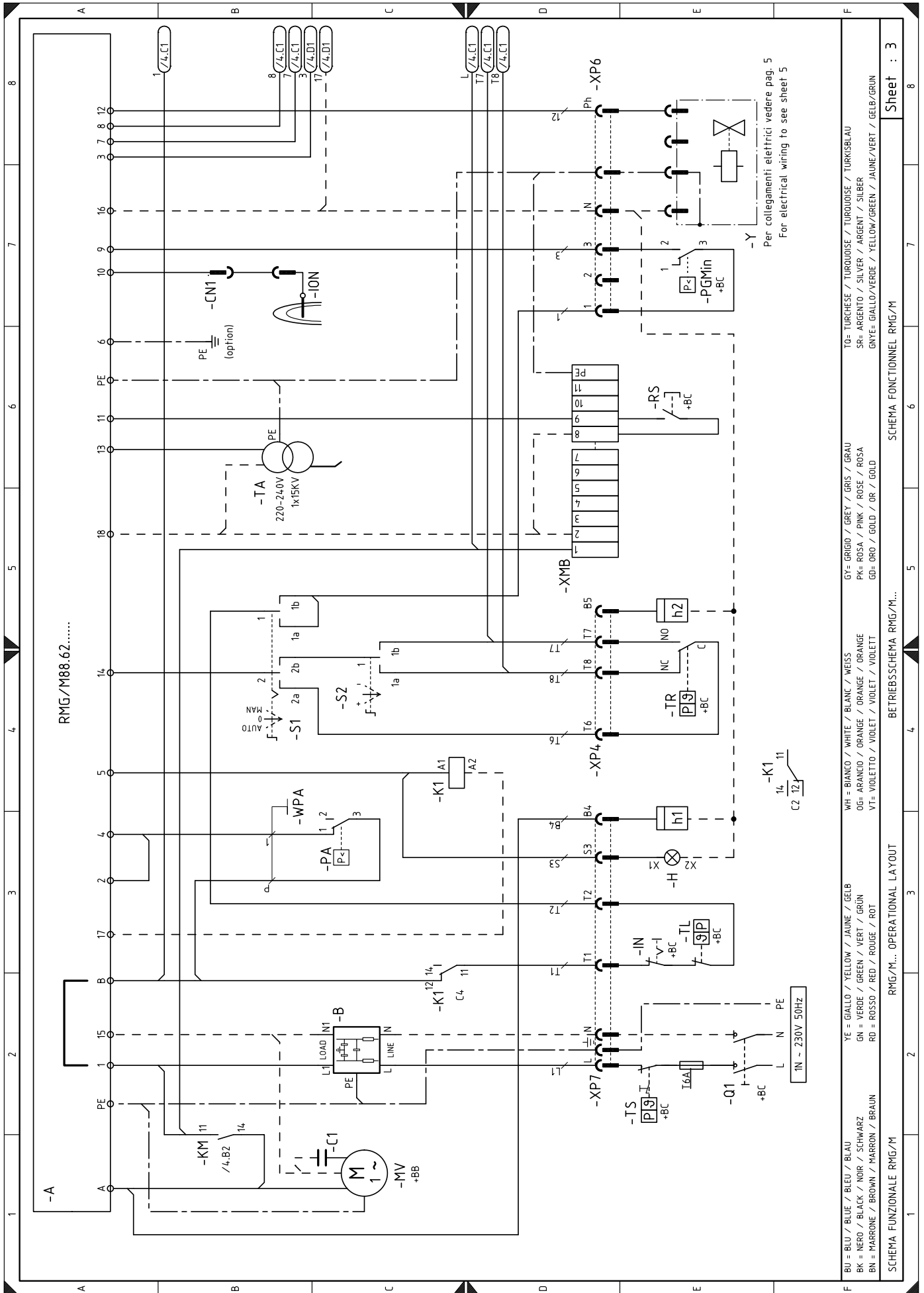

- BU = BLU / BLUE / BLEU / BLAU
- BK = NERO / BLACK / NOIR / SCHWARZ
- BN = MARRONE / BROWN / MARRON / BRAUN
- YE = GIALLO / YELLOW / JAUNE / GELB
- GN = VERDE / GREEN / VERT / GRÜN
- RD = ROSSO / RED / ROUGE / ROT
- WH = BIANCO / WHITE / BLANC / WEISS
- OG = ARANCIO / ORANGE / ORANGE / ORANGE
- VT = VIOLETTA / VIOLET / VIOLET / VIOLETT
- GY = GRIGIO / GREY / GRIS / GRAU
- PK = ROSA / PINK / ROSE / ROSA
- GD = ORO / GOLD / OR / GOLD
- TO = TURCHESE / TURQUOISE / TURKOISE / TURKISBLAU
- SR = ARGENTO / SILVER / ARGENT / SILBER
- GNVE = GIALLO/VERDE / YELLOW/GREEN / JAUNE/VERT / GELB/GRÜN

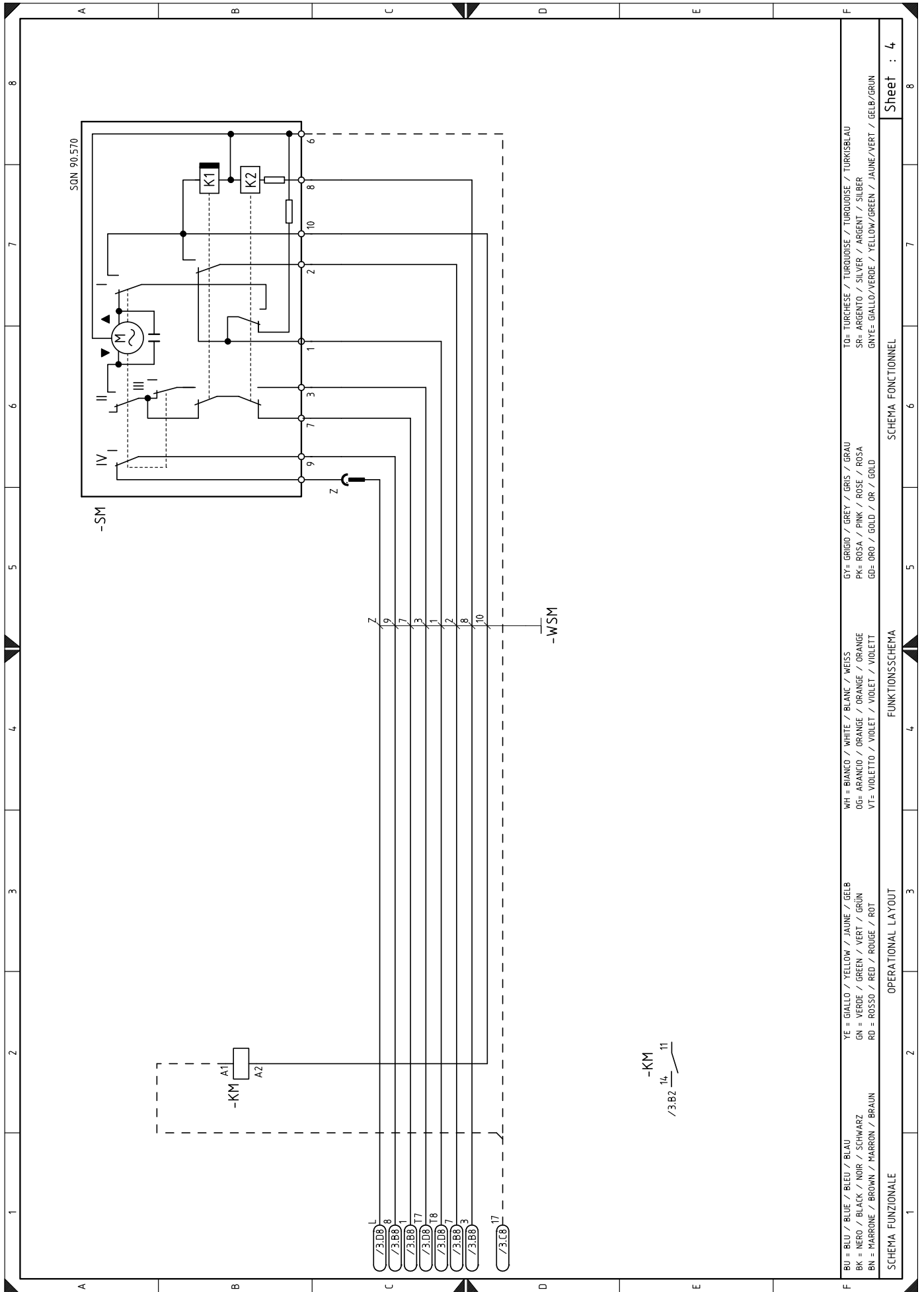

-KM  
14 11  
/3.B2

BU = BLU / BLUE / BLEU / BLAU	YE = GIALLO / YELLOW / JAUNE / GELB	WH = BIANCO / WHITE / BLANC / WEISS	GY = GRIGIO / GREY / GRIS / GRAU	TO = TURSCHSE / TURQUOISE / TURKOISE / TURKISBLAU	Sheet : 4
BK = NERO / BLACK / NOIR / SCHWARZ	GN = VERDE / GREEN / VERT / GRÜN	OG = ARANCIO / ORANGE / ORANGE / ORANGE	PK = ROSA / PINK / ROSE / ROSA	SR = ARGENTO / SILVER / ARGENT / SILBER	8
BN = MARRONE / BROWN / MARRON / BRAUN	RD = ROSSO / RED / ROUGE / ROT	VT = VIOLETTO / VIOLET / VIOLET / VIOLETT	GD = ORO / GOLD / OR / GOLD	GNVE = GIALLO/VERDE / YELLOW/GREEN / JAUNE/VERT / GELB/GRÜN	7
SCHEMA FUNZIONALE			SCHEMA FONCTIONNEL		
OPERATIONAL LAYOUT			FUNKTIONSSCHEMA		
1	2	3	4	5	6



INGRESSI POSSIBILI PER LA MODULAZIONE CON SONDE RIELLO  
 POSSIBILITY OF MODULATION INPUT WITH RIELLO PROBES  
 POSSIBILITÉ D' ENTRÉE POUR MODULATION AVEC SONDES RIELLO  
 MÖGLICHE MODULATIONSEINGABE MIT RIELLO SONDE

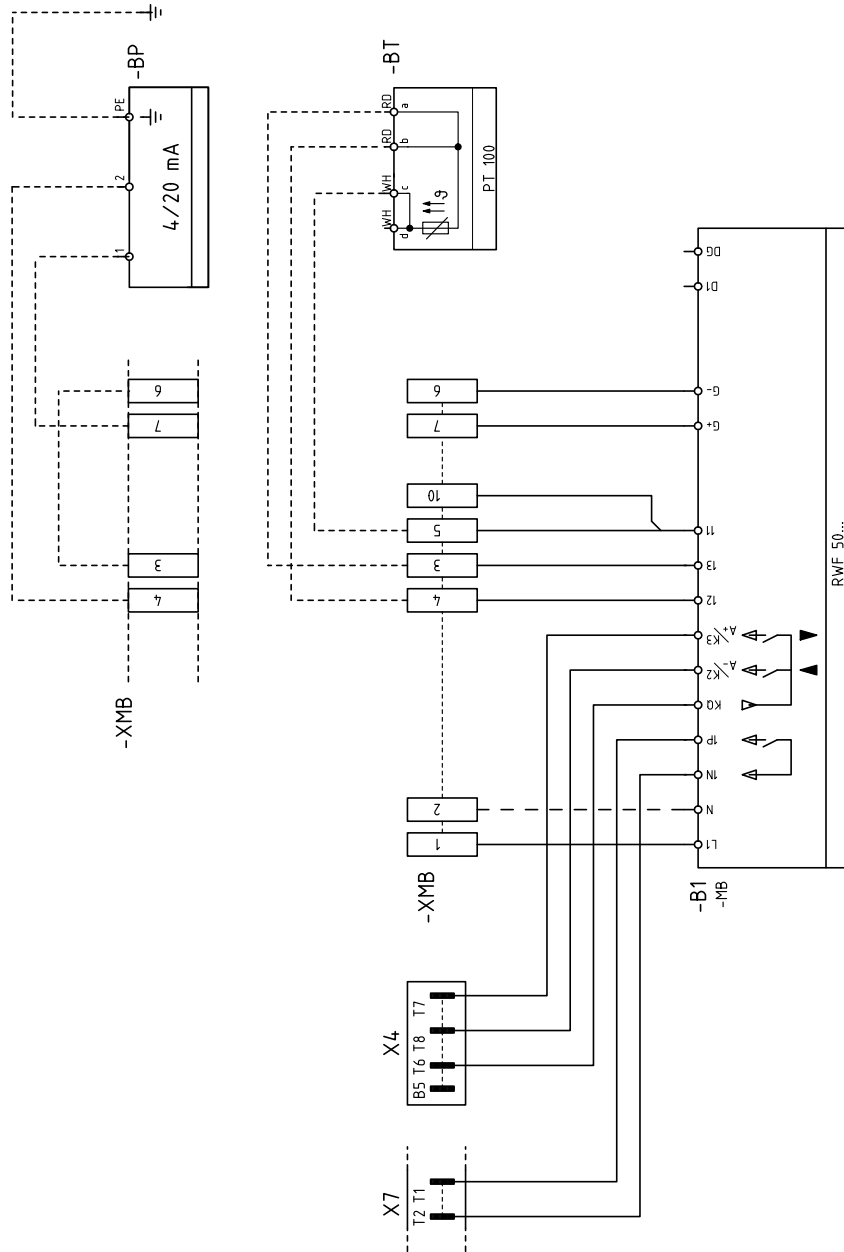

BU = BLU / BLUE / BLEU / BLAU	YE = GIALLO / YELLOW / JAUNE / GELB	WH = BIANCO / WHITE / BLANC / WEISS	GY = GRIGIO / GREY / GRIS / GRAU	TO = TURCHESE / TURBOISE / TURKOISE / TURKISBLAU
BK = NERO / BLACK / NOIR / SCHWARZ	GN = VERDE / GREEN / VERT / GRÜN	OG = ARANCIO / ORANGE / ORANGE / ORANGE	PK = ROSA / PINK / ROSE / ROSA	SR = ARGENTO / SILVER / ARGENT / SILBER
BN = MARRONE / BROWN / MARRON / BRAUN	RD = ROSSO / RED / ROUGE / ROT	VT = VIOLETTA / VIOLET / VIOLET / VIOLETT	GD = ORO / GOLD / OR / GOLD	GNVE = GIALLO/VERDE / YELLOW/GREEN / JAUNE/VERT / GELB/GRÜN
COLLEGAMENTI ELETTRICI KIT RWF50 ESTERNO		ELECTRICAL CONNECTIONS FOR EXTERNAL RWF50 KIT		RACCORDMENTS ÉLECTRIQUE KIT RWF50 EXTÉRIEUR
				Sheet : 6

**Wiring layout key**

+BB	Burners components
+BC	Boiler components
A	Flame control
B	Filter to protect against radio disturbance
B1	Output regulator RWF50
BP	Pressure probe
BT	Probe Pt100, 3 wires
C1	Motor capacitor
CN1	Ionisation probe connector
H	Remote lockout signalling
H1	Lockout YVPS
IN	Burner manual stop switch
ION	Ionisation probe
h1	Hour counter
h2	Hour counter
K1	Relay
KM	Motor contactor
MV	Fan motor
PA	Air pressure switch
PGMin	Minimum gas pressure switch
Q2	Single-phase disconnecting switch
RS	Reset button
S1	Off / automatic / manual selector
S2	Power increase / power reduction selector
SM	Servomotor
TA	Ignition transformer
TL	Limit thermostat/pressure switch
TR	Adjustment thermostat/pressure switch
TS	Safety thermostat/pressure switch
Y	Gas regulator valve + gas safety valve
YVPS	Valve leak detection device
XMB	Burner terminal strip
XP4	4-pole socket
XP6	6- pole socket
XP7	7-pole socket
X4	4-pin plug
X6	6-pin plug
X7	7-pin plug



---

**RIELLO**

RIELLO S.p.A.  
I-37045 Legnago (VR)  
Tel.: +39.0442.630111  
[http:// www.riello.it](http://www.riello.it)  
[http:// www.riello.com](http://www.riello.com)