

GB **Forced draught gas burners**

Modulating operation

CE

**UK
CA**

EAC

CODE	MODEL	TYPE
20068343 - 20068351 20061373	RS 310/M MZ	1142T
20068361 - 20067141	RS 410/M MZ	1143T
20068027	RS 510/M MZ	1144T
20066706	RS 610/M MZ	1145T



Translation of the original instructions

1	Information and general warnings.....	3
1.1	Information about the instruction manual	3
1.1.1	Introduction.....	3
1.1.2	General dangers.....	3
1.1.3	Other symbols	3
1.1.4	Delivery of the system and the instruction manual	4
1.2	Guarantee and responsibility.....	4
2	Safety and prevention.....	5
2.1	Introduction.....	5
2.2	Personnel training	5
3	Technical description of the burner	6
3.1	Burner designation	6
3.2	Models available.....	6
3.3	Technical data	7
3.4	Electrical data.....	7
3.5	Burner categories - Countries of destination	7
3.6	Maximum dimensions.....	8
3.7	Firing rates	9
3.8	Test boiler.....	10
3.9	Burner equipment.....	10
3.10	Burner description	11
3.11	Electrical panel description.....	12
3.12	Flame control RMG88.....	13
3.13	Servomotor SQM40	14
3.14	Calibration of the thermal relay	15
4	Installation	16
4.1	Notes on safety for the installation	16
4.2	Handling	16
4.3	Preliminary checks	16
4.4	Operating position	17
4.5	Preparing the boiler	17
4.5.1	Boring the boiler plate	17
4.5.2	Blast tube length.....	17
4.6	Securing the burner to the boiler	17
4.7	Access to head internal part.....	18
4.8	Probe-electrode position	18
4.9	Gas butterfly valve.....	19
4.10	Combustion head adjustment.....	19
4.11	Gas feeding	21
4.11.1	Gas feeding line (Example) - Please refer to the gas train documentation	21
4.11.2	Gas train	22
4.11.3	Gas train installation.....	22
4.11.4	Gas pressure	23
4.12	Electrical wiring	24
4.12.1	Supply cables and external connections passage	24
5	Start-up, calibration and operation of the burner	25
5.1	Notes on safety for the first start-up	25
5.2	Adjustments prior to ignition	25
5.3	Servomotor adjustment	26
5.4	Burner start-up	27
5.5	Burner ignition	27
5.6	Air / fuel adjustment.....	27

5.6.1	Burner adjustment.....	28
5.6.2	Output upon ignition.....	28
5.6.3	Maximum output.....	28
5.6.4	Minimum output.....	29
5.6.5	Intermediate outputs.....	29
5.7	Pressure switch adjustment.....	30
5.7.1	Air pressure switch - check CO.....	30
5.7.2	Maximum gas pressure switch.....	30
5.7.3	Minimum gas pressure switch.....	30
5.8	Operation sequence of the burner.....	31
5.8.1	Burner start-up.....	31
5.8.2	Operation.....	31
5.8.3	Ignition failure.....	31
5.8.4	Burner flame goes out during operation.....	31
5.9	Burner start-up cycle diagnostics.....	32
5.9.1	Resetting of flame control and diagnostics use.....	32
5.9.2	Flame control reset.....	32
5.9.3	Visual diagnostics.....	32
5.9.4	Software diagnostics.....	32
5.10	Normal operation / flame detection time.....	33
6	Maintenance.....	34
6.1	Notes on safety for the maintenance.....	34
6.2	Maintenance programme.....	34
6.2.1	Maintenance frequency.....	34
6.2.2	Safety test - with no gas supply.....	34
6.2.3	Checking and cleaning.....	34
6.2.4	Safety components.....	35
6.3	Opening the burner.....	35
6.4	Closing the burner.....	35
7	Faults - Possible causes - Solutions.....	36
A	Appendix - Accessories.....	38
B	Appendix - Electrical panel layout.....	39

1 Information and general warnings

1.1 Information about the instruction manual

1.1.1 Introduction

The instruction manual supplied with the burner:

- is an integral and essential part of the product and must not be separated from it; it must therefore be kept carefully for any necessary consultation and must accompany the burner even if it is transferred to another owner or user, or to another system. If the manual is lost or damaged, another copy must be requested from the Technical Assistance Service of the area;
- is designed for use by qualified personnel;
- offers important indications and instructions relating to the installation safety, start-up, use and maintenance of the burner.

Symbols used in the manual

In some parts of the manual you will see triangular DANGER signs. Pay great attention to these, as they indicate a situation of potential danger.

1.1.2 General dangers

The **dangers** can be of **3 levels**, as indicated below.



Maximum danger level!
This symbol indicates operations which, if not carried out correctly, cause serious injury, death or long-term health risks.



This symbol indicates operations which, if not carried out correctly, may cause serious injury, death or long-term health risks.



This symbol indicates operations which, if not carried out correctly, may cause damage to the machine and/or injury to people.

1.1.3 Other symbols



DANGER: LIVE COMPONENTS
This symbol indicates operations which, if not carried out correctly, lead to electric shocks with lethal consequences.



DANGER: FLAMMABLE MATERIAL
This symbol indicates the presence of flammable materials.



DANGER: BURNING
This symbol indicates the risks of burns due to high temperatures.



DANGER: CRUSHING OF LIMBS
This symbol indicates the presence of moving parts: danger of crushing of limbs.



WARNING: MOVING PARTS

This symbol indicates that you must keep limbs away from moving mechanical parts; danger of crushing.



DANGER: EXPLOSION

This symbol signals places where an explosive atmosphere may be present. An explosive atmosphere is defined as a mixture - under atmospheric conditions - of air and flammable substances in the form of gases, vapours, mist or dust in which, after ignition has occurred, combustion spreads to the entire unburned mixture.



PERSONAL PROTECTION EQUIPMENT

These symbols indicate the equipment that must be worn and kept by the operator for protection against threats against safety and/or health while at work.



OBLIGATION TO ASSEMBLE THE COVER AND ALL THE SAFETY AND PROTECTION DEVICES

This symbol signals the obligation to reassemble the cover and all the safety and protection devices of the burner after any maintenance, cleaning or checking operations.



ENVIRONMENTAL PROTECTION

This symbol gives indications for the use of the machine with respect for the environment.



IMPORTANT INFORMATION

This symbol indicates important information that you must bear in mind.



This symbol indicates a list.

Abbreviations used

Ch.	Chapter
Fig.	Figure
Page	Page
Sec.	Section
Tab.	Table

1.1.4 Delivery of the system and the instruction manual

When the system is delivered, it is important that:

- the instruction manual is delivered to the user by the system manufacturer, with the recommendation to keep it in the room where the heat generator is to be installed.
- The instruction manual shows:
 - the serial number of the burner;

.....

- the address and telephone number of the nearest Assistance Centre

.....

.....

.....

- The system supplier must carefully inform the user about:
 - the use of the system;
 - any further tests that may be required before activating the system;
 - maintenance, and the need to have the system checked at least once a year by a representative of the manufacturer or another specialised technician. To ensure a periodic check, the manufacturer recommends the drawing up of a Maintenance Contract.

1.2 Guarantee and responsibility

The manufacturer guarantees its new products from the date of installation, in accordance with the regulations in force and/or the sales contract. At the moment of the first start-up, check that the burner is integral and complete.

**WARNING**

Failure to observe the information given in this manual, operating negligence, incorrect installation and carrying out of non authorised modifications will result in the annulment by the manufacturer of the guarantee that it supplies with the burner.

In particular, the rights to the guarantee and the responsibility will no longer be valid, in the event of damage to things or injury to people, if such damage/injury was due to any of the following causes:

- incorrect installation, start-up, use and maintenance of the burner;
- improper, incorrect or unreasonable use of the burner;
- intervention of unqualified personnel;
- carrying out of unauthorised modifications on the equipment;
- use of the burner with safety devices that are faulty, incorrectly applied and/or not working;
- installation of untested supplementary components on the burner;
- powering of the burner with unsuitable fuels;
- faults in the fuel supply system;
- continuation of use of the burner when a fault has occurred;
- repairs and/or overhauls incorrectly carried out;
- modification of the combustion chamber with inserts that prevent the regular development of the structurally established flame;
- insufficient and inappropriate surveillance and care of those burner components most likely to be subject to wear and tear;
- use of non-original components, including spare parts, kits, accessories and optional;
- force majeure.

The manufacturer furthermore declines any and every responsibility for the failure to observe the contents of this manual.

2 Safety and prevention

2.1 Introduction

The burners have been designed and built in compliance with current regulations and directives, applying the known technical rules of safety and envisaging all the potential danger situations.

It is necessary, however, to bear in mind that the imprudent and clumsy use of the equipment may lead to situations of death risk for the user or third parties, as well as the damaging of the burner or other items. Inattention, thoughtlessness and excessive confidence often cause accidents; the same applies to tiredness and sleepiness.

It is a good idea to remember the following:

- The burner must only be used as expressly described. Any other use should be considered improper and therefore dangerous.

In particular:

it can be applied to boilers operating with water, steam, diathermic oil, and to other uses expressly foreseen by the manufacturer;

the type and pressure of the fuel, the voltage and frequency of the electrical power supply, the minimum and maximum deliveries for which the burner has been regulated, the pressurisation of the combustion chamber, the dimensions of the combustion chamber and the room temperature must all be within the values indicated in the instruction manual.

- Modification of the burner to alter its performance and destinations is not allowed.
- The burner must be used in exemplary technical safety conditions. Any disturbances that could compromise safety must be quickly eliminated.
- Opening or tampering with the burner components is not allowed, apart from the parts requiring maintenance.
- Only those parts envisaged by the manufacturer can be replaced.



The manufacturer guarantees safety and proper functioning only if all burner components are intact and positioned correctly.

2.2 Personnel training

The user is the person, body or company that has acquired the machine and intends to use it for the specific purpose. He is responsible for the machine and for the training of the people working around it.

The user:

- undertakes to entrust the machine exclusively to suitably trained and qualified personnel;
- undertakes to inform his personnel in a suitable way about the application and observance of the safety instructions. With that aim, he undertakes to ensure that everyone knows the use and safety instructions for his own duties;
- Personnel must observe all the danger and caution indications shown on the machine.
- Personnel must not carry out, on their own initiative, operations or interventions that are not within their province.
- Personnel must inform their superiors of every problem or dangerous situation that may arise.
- The assembly of parts of other makes, or any modifications, can alter the characteristics of the machine and hence compromise operating safety. The manufacturer therefore declines any and every responsibility for any damage that may be caused by the use of non-original parts.

In addition:



- must take all the measures necessary to prevent unauthorised people gaining access to the machine;
- the user must inform the manufacturer if faults or malfunctioning of the accident prevention systems are noticed, along with any presumed danger situation;
- personnel must always use the personal protective equipment envisaged by legislation and follow the indications given in this manual.

3 Technical description of the burner

3.1 Burner designation

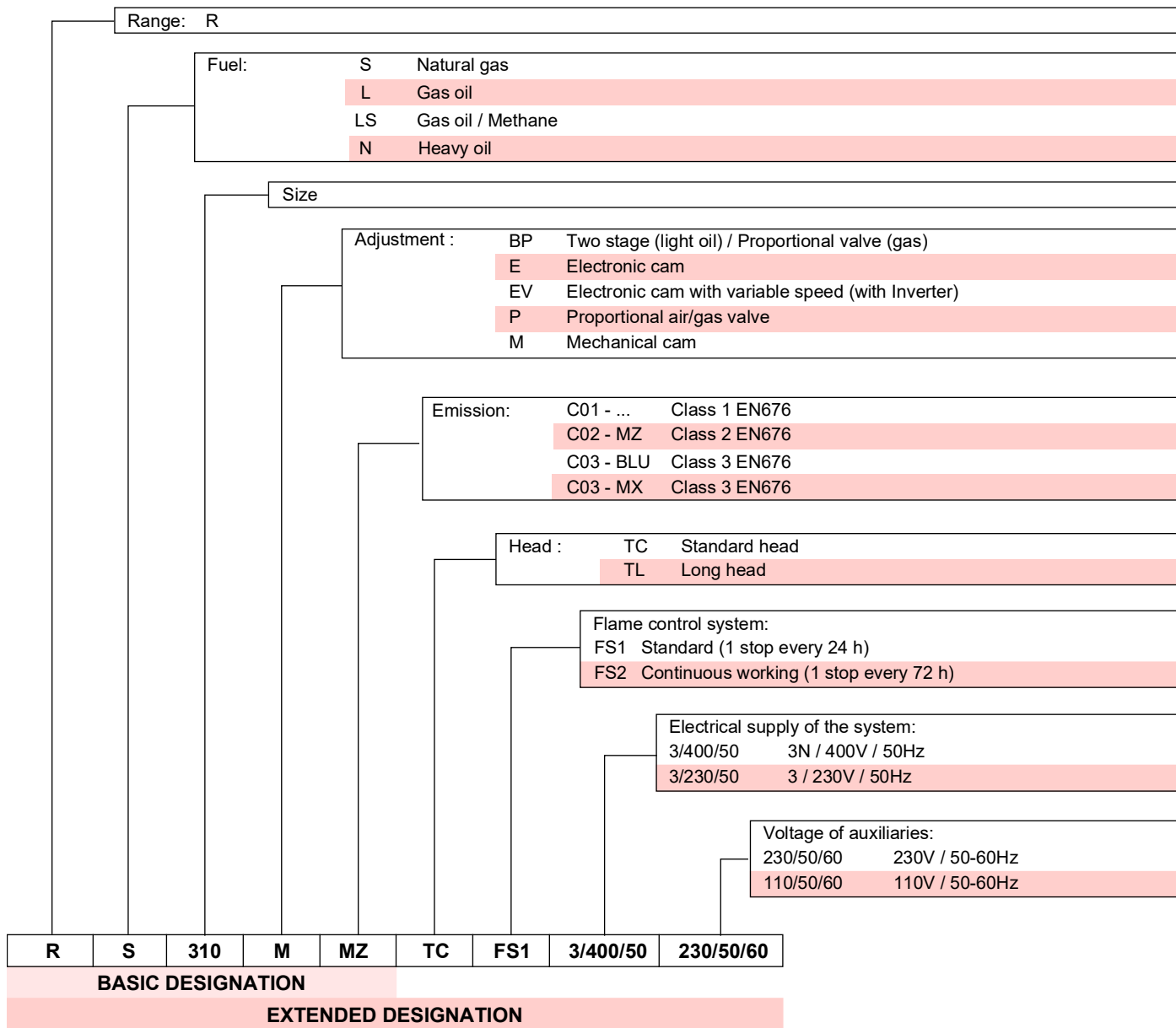

3.2 Models available

Designation	Voltage	Start-up	Code
RS 310/M MZ	3/400/50	Star/Triangle	20061373
	3/230/50	Direct	20068343
	3/400/50	Direct	20068351
RS 410/M MZ	3/400/50	Star/Triangle	20067141
	3/400/50	Direct	20068361
RS 510/M MZ	3/400/50	Star/Triangle	20068027
RS 610/M MZ	3/400/50	Star/Triangle	20066706

Tab. A

3.3 Technical data

Model			RS 310/M MZ	RS 410/M MZ	RS 510/M MZ	RS 610/M MZ
Type			1142T	1143T	1144T	1145T
Power ⁽¹⁾ Delivery ⁽¹⁾	min - max	kW	600/1300 ÷ 3900	800/2000 ÷ 4900	800/2200 ÷ 5520	820/2400 ÷ 6300
Fuels			Natural gas: G20 (methane gas) - G25			
Gas pressure at max. output ⁽²⁾ Gas: G20/G25		mbar	33.2/49,5	41.7/62	48.9/73	64.6/96.4
Operation			Intermittent			
Standard applications			Boilers: water, steam, diathermic oil			
Ambient temperature		°C	0 - 40			
Combustion air temperature		°C max	60			
Noise levels ⁽²⁾	Sound pressure	dB(A)	78	80	82,5	85
	Sound power		89	91	93,5	96
Weight		Kg	250			280
CE			CE-0085CP0166			

Tab. B

(1) Reference conditions: Room temperature 20°C - Gas temperature 15°C - Barometric pressure 1013 mbar - Altitude 0 m a.s.l.

(2) Sound pressure measured in manufacturer's combustion laboratory, with burner operating on test boiler and at maximum rated output. The sound power is measured with the "Free Field" method, as per EN 15036, and according to an "Accuracy: Category 3" measuring accuracy, as set out in EN ISO 3746.

3.4 Electrical data

DIRECT START UP

Model		RS 310/M MZ	RS 410/M MZ
Code		20068343 - 20068351	20068361
Main electrical supply		3 ~ 230V +/-10% 50 Hz	3N ~ 400V +/-10% 50 Hz
Absorbed electrical power	kW max	9	10.8
Protection level		IP 54	

STAR - TRIANGLE START UP

Model		RS 310/M MZ	RS 410/M MZ	RS 510/M MZ	RS 610/M MZ
Code		20061373	20067141	20068027	20066706
Main electrical supply		3N ~ 400V +/-10% 50 Hz			
Absorbed electrical power	kW max	9	10.8	13.7	16.9
Protection level		IP 54			

Tab. C

3.5 Burner categories - Countries of destination

Gas category	Destination country
I _{2H}	AT - BG - CH - CZ - DK - EE - ES - FI - GB - GR - HU - IE - IS - IT - LT - LV - NO - PT - RO - SE - SI - SK - TR
I _{2E (R)}	BE
I _{2E}	LU - PL
I _{2ELL}	DE
I _{2EK}	NL
I _{2Er}	FR

Tab. D

3.6 Maximum dimensions

The maximum dimensions of the burner are given in Fig. 1.

Bear in mind that inspection of the combustion head requires the burner to be opened and the rear part turned on the hinge.

The maximum dimensions of the open burner are indicated by the L and R positions.

The I position is reference for the refractory thickness of the boiler door.



* The gas adaptor is set also for DN 80 bore.

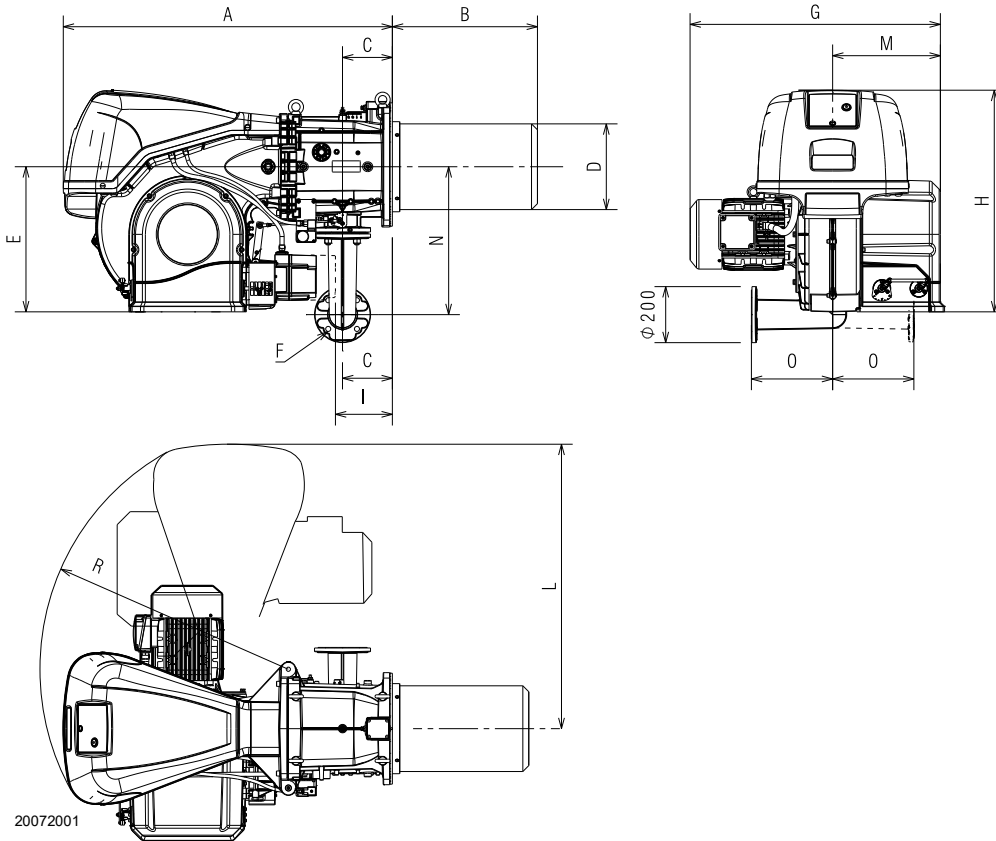

Fig. 1

mm	A	B	C	D	E	F*	G	H	I**	L	M	N	O	R
RS 310/M MZ	1178	519	178	306	520	DN65	890	790	177	1015	400	528	290	890
RS 410/M MZ	1178	519	178	306	520	DN65	930	790	177	1015	400	528	290	890
RS 510/M MZ	1178	519	178	306	520	DN65	930	790	177	1015	400	528	290	890
RS 610/M MZ	1178	500	178	330	520	DN65	980	790	177	1015	400	528	290	890

Tab. E

** Maximum position for the extraction of the servomotor cover.

3.7 Firing rates

The **MAXIMUM OUTPUT** is chosen from within the diagram area (Fig. 2).

The **MINIMUM OUTPUT** must not be lower than the minimum limit of the diagram:



The firing rate value (Fig. 2) has been obtained considering an ambient temperature of 20°C, an atmospheric pressure of 1013 mbar (approx. 0 m a.s.l.), and with the combustion head adjusted as shown on page 19.

Model	kW
RS 310/M MZ	600
RS 410/M MZ	800
RS 510/M MZ	800
RS 610/M MZ	820

Tab. F

20072010

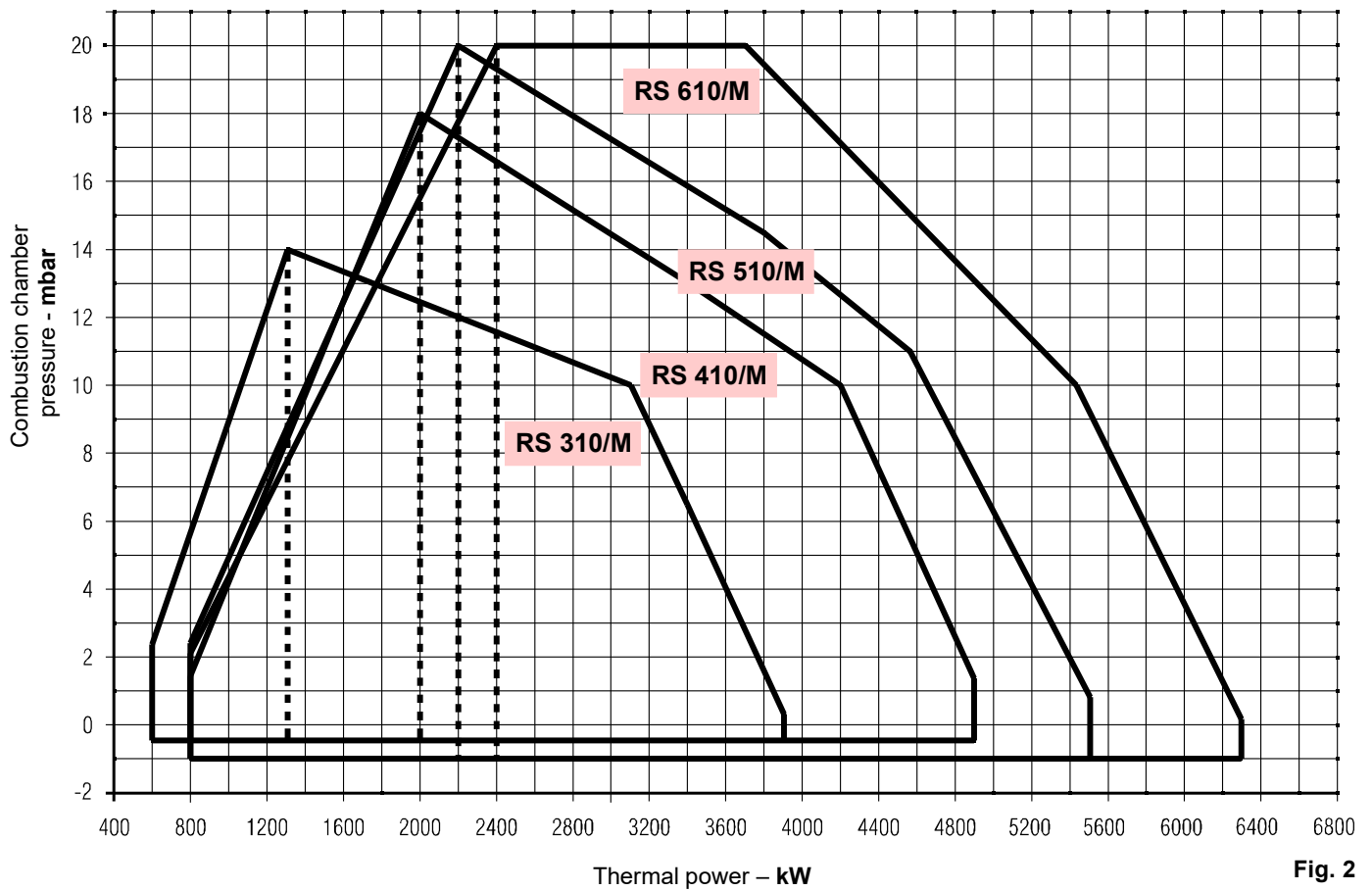

Fig. 2

3.8 Test boiler

The burner/boiler combination does not pose any problems if the boiler is EC approved and its combustion chamber dimensions are similar to those indicated in the diagram (Fig. 3).

If the burner must be combined with a boiler that has not been EC approved and/or its combustion chamber dimensions are clearly smaller than those indicated in the diagram, consult the manufacturer.

The firing rates were set in relation to special test boilers, according to EN 676 regulations.

In Fig. 3 you can see the diameter and length of the test combustion chamber.

Example: RS 610/M MZ

Output 5000 kW - diameter 100 cm - length 5 m

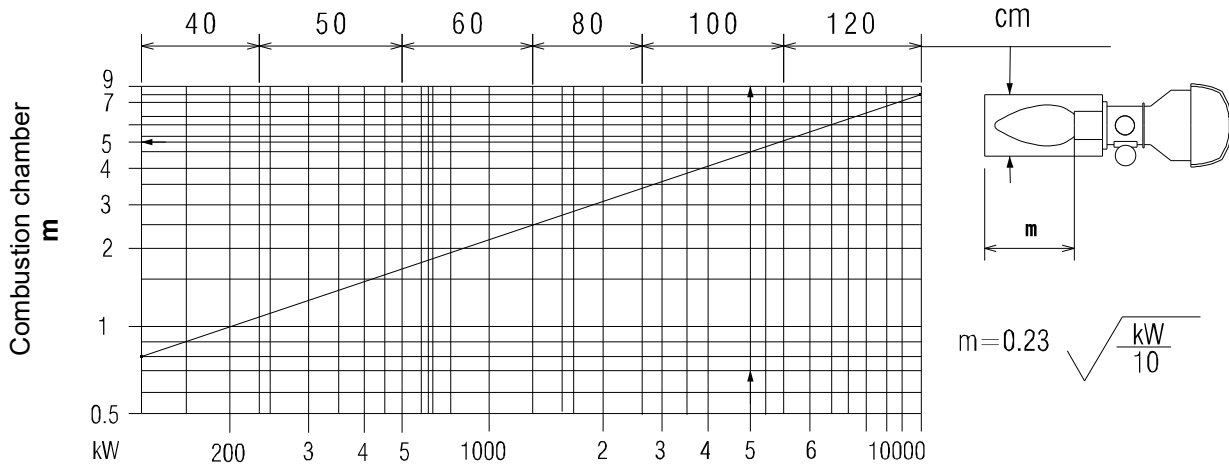

20057548

Fig. 3

3.9 Burner equipment

- Gasket for gas train adaptor. No. 1
- Adaptor for gas train. No. 1
- Screws for fixing the gas train adaptor: M 16 x 70 No. 4
- Thermal insulation screen No. 1
- M 18 x 60 screws to secure the burner flange to the boiler No. 4
- Cable grommets kit for optional electrical wiring input. . . . No. 1
- M16 x 6 studs for fixing the gas elbow to the pipe coupling . .No. 4
- M16 nuts to fix the gas elbow to the pipe coupling No. 4
- Instructions. No. 1
- Spare parts list No. 1



It is recommended to tighten the screws of the gas flange with a tightening torque of **40 Nm ±10%**.



Tighten the nuts gradually (first to 30%, then to 60% up to 100%) according to the cross pattern shown in the figure.

3.10 Burner description

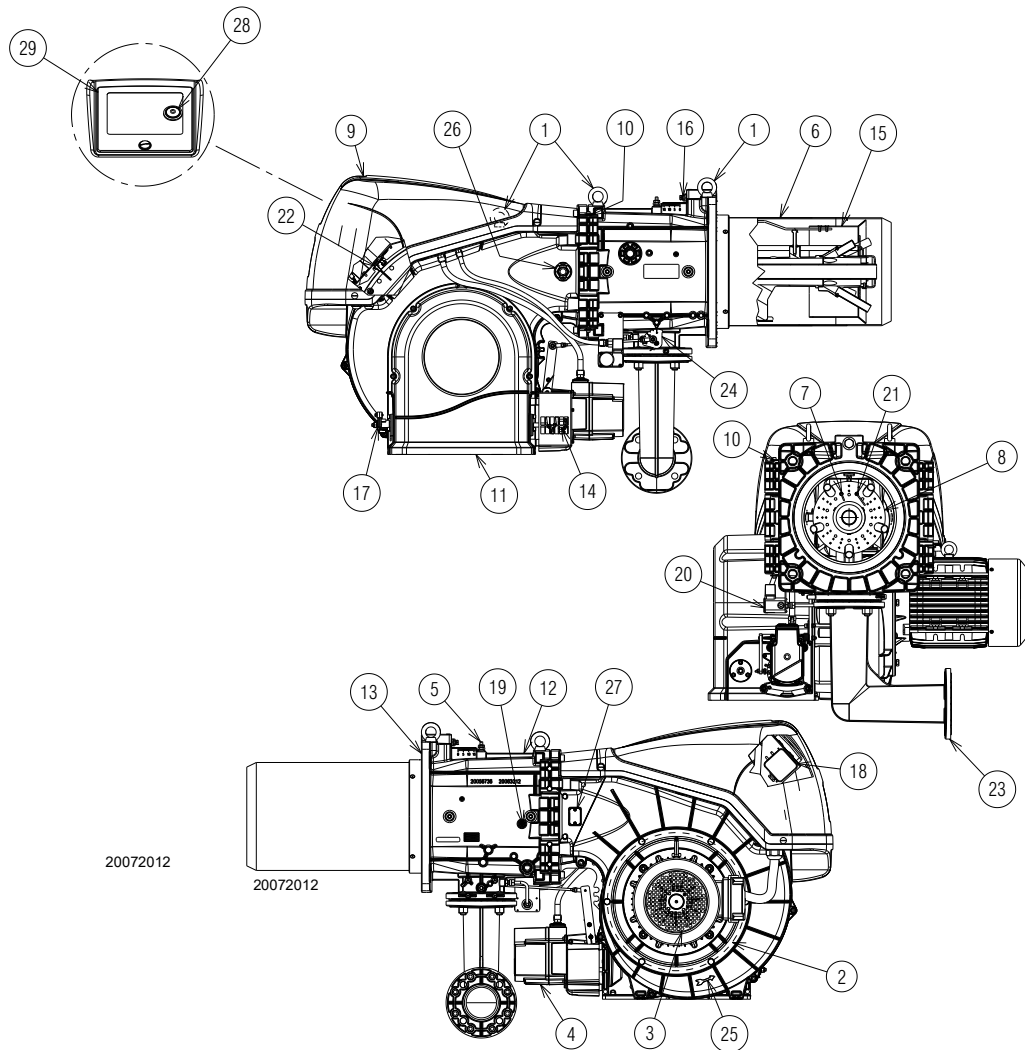

20072012

20072012

Fig. 4

- 1 Lifting rings
- 2 Fan
- 3 Fan motor
- 4 Air damper servomotor
- 5 Combustion head gas pressure test point
- 6 Combustion head
- 7 Ignition electrode
- 8 Flame stability disk
- 9 Electrical panel casing
- 10 Hinge for opening the burner
- 11 Fan air inlet
- 12 Pipe coupling
- 13 Gasket for boiler fixing
- 14 Adjustable profile cam
- 15 Shutter
- 16 Combustion head movement screw
- 17 Air damper control lever
- 18 Air pressure switch
- 19 Combustion head air pressure test point
- 20 Maximum gas pressure switch with pressure test point
- 21 Flame sensor probe
- 22 Pressure test point for air pressure switch “+”
- 23 Gas train adapter
- 24 Gas butterfly valve control lever
- 25 Indication for checking the rotation direction of the purging motor
- 26 Flame inspection window
- 27 Provision for flame sensor kit
- 28 Reset button
- 29 Transparent protection



The burner can be opened to the right or to the left without links to the fuel supply side.



To open the burner see section “Access to head internal part” on page 18.

3.11 Electrical panel description

**STAR/TRIANGLE
START UP**

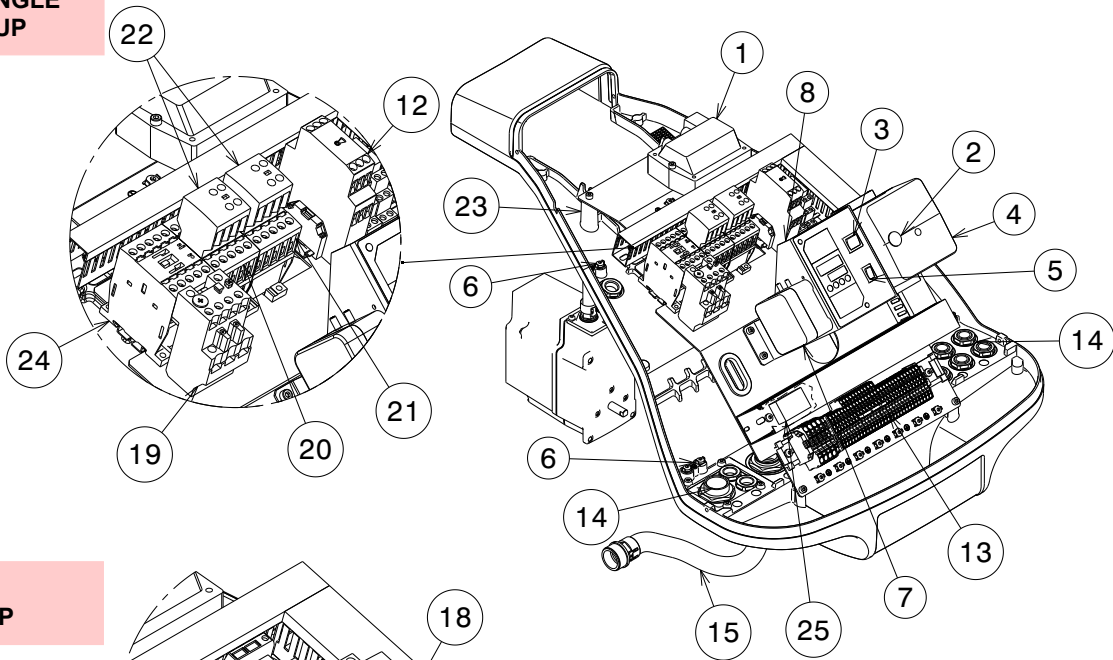

**DIRECT
START UP**

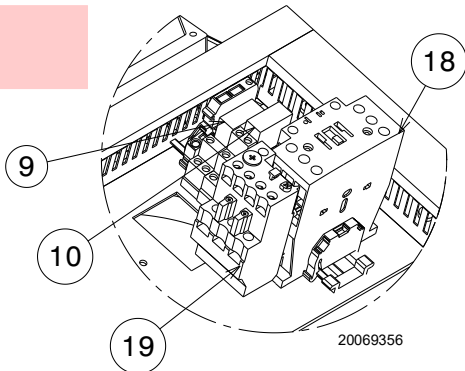

Fig. 5

- 1 Ignition transformer
- 2 Burner state indicator light and reset button. For further information see section "Burner ignition" on page 27
- 3 OFF-automatic-manual selector
- 4 Flame control
- 5 Power increase - power reduction selector
- 6 Earth terminal
- 7 Air pressure switch
- 8 Bracket for applying the kits
- 9 Relay with clean contacts for signalling the burner is operating
- 10 Relay with clean contacts for signalling the burner is in lock-out
- 11 Auxiliary circuits fuse (includes a spare fuse)
- 12 Timer for star/triangle start up
- 13 Main terminal supply board
- 14 Supply cables and external connections passage. See section "Electrical wiring" on page 24.
- 15 Motor cables sheath
- 16 Maximum gas pressure switch sheath
- 17 Servomotor sheath
- 18 Direct start up line contactor
- 19 Thermal relay (with reset button)
- 20 Triangle contactor (Star/triangle start up)
- 21 Star contactor (Star/triangle start up)
- 22 Auxiliary contacts (Star/triangle start up)
- 23 Ionisation probe cable
- 24 Star/triangle start-up line contactor
- 25 Suppressor

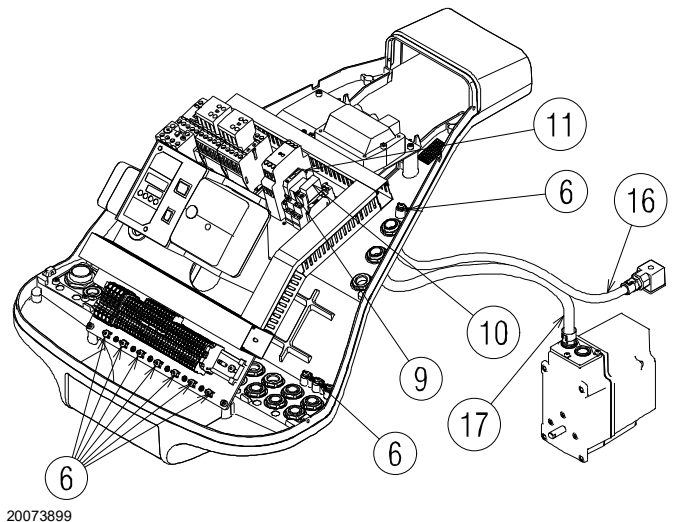

Fig. 6

3.12 Flame control RMG88...

Warnings



To avoid accidents, material or environmental damage, observe the following instructions!

The flame control RMG88... is a safety device! Avoid opening or modifying it, or forcing its operation. Riello S.p.A. cannot assume any responsibility for damage resulting from unauthorised interventions!

- All interventions (assembly and installation operations, assistance, etc.) must be carried out by qualified personnel.
- Before modifying the wiring in the flame control connection area, fully disconnect the system from the power supply (omnipolar separation). Check the system is not powered and cannot be accidentally reconnected. Failure to do this will lead to the risk of electrocution.
- Protection against electrocution from the flame control and all connected electric components is obtained with the correct assembly.
- Before any intervention (assembly and installation operations, assistance, etc.), ensure the wiring is in order and that the parameters are correctly set, then make the safety checks.
- Falls and collisions can negatively affect the safety functions.
In this case, the flame control must not be operated, even if it displays no evident damage.
- Press the reset button of the burner lockout command or the reset button (by applying a force of not more than 10 N), without the aid of tools or sharp objects.

For the safety and reliability of the flame control, comply with the following instructions:

- avoid conditions that can favour the development of condensate and humidity. Otherwise, before switching on again, make sure that the entire flame control is perfectly dry!
- Static charges must be avoided since they can damage the flame control's electronic components when touched.



Fig. 7

S8906

Technical data

Mains voltage	AC 220...240 V +10 % / -15 %
Mains frequency	50 / 60 Hz ±6%
Power absorption	20 VA
Protection level	IP20
Safety class	I
Weight	approx. 260g
Cable length	
Thermostat cable	Max. 20 m at 100 pF/m
Air pressure switch	Max. 1 m at 100 pF/m
Gas pressure switch	Max. 20 m at 100 pF/m
Remote reset	Max. 20 m at 100 pF/m
CPI	Max. 1 m at 100 pF/m
Environmental conditions:	
Operation	DIN EN 60721-3-3
Climatic conditions	Class 3K3
Mechanical conditions	Class 3M3
Temperature range	-20...+60°C
Humidity	< 95 % r.h.

Mechanical structure

The flame control is made of plastic to resist knocks, heat and flame propagation.

The flame control contains the following components:

- a microprocessor that controls the program sequence, and a relay for controlling the load
- an electronic flame signal amplifier
- a built-in reset button with 3 signalling colours (LED) for status and error messages.

3.13 Servomotor SQM40 ...

Warnings



WARNING

To avoid accidents, material or environmental damage, observe the following instructions!

Avoid opening, modifying or forcing the servomotor.

- All interventions (assembly and installation operations, assistance, etc.) must be carried out by qualified personnel.
- Falls and collisions can negatively affect the safety functions. In this case, the servomotor must not be operated, even if it displays no evident damage.
- Fully disconnect the burner from the mains when working near terminals and servomotor connections.
- Condensation and exposure to water are not allowed.
- For safety reasons, the servomotor must be checked after long periods of non-use.



Fig. 8

S8907

Technical data

Mains voltage	230 V -15% +10%
Mains frequency	50 / 60 Hz
Power absorption	7 ... 15 VA
Motor	Synchronous
Drive angle	Varying between 0° and 135°



WARNING

Absolutely do not adjust the red cam No. 1 more than 90° to prevent serious or irreversible damage to the mechanical adjustment parts.

Protection level	Max. IP 66, with appropriate cable entry
Cable entry	2 x M16
Cable connection	terminal board for 0.5mm ² (min.) and 2.5mm ² (max.)
Rotation direction	Anticlockwise
Rated torque (max.)	10 Nm
Holding torque	5 Nm
Operation time	30 s. at 90°
Weight	approx. 2 kg
Environmental conditions:	
Operation	-20...+60° C
Transport and storage	-20...+60°C

3.14 Calibration of the thermal relay

The thermal relay serves to avoid damage to the motor due to an excessive absorption increase or if a phase is missing.

For calibration **2)**, see the table in the wiring diagram.

To reset, in case of an intervention of the thermal relay, press the "RESET" button 1) of Fig. 9.

The red "TEST" button 3) opens the NC (95-96) contact and stops the motor.



CAUTION

The automatic reset can be dangerous. This operation is not foreseen in the burner operation. **Therefore do not position the "RESET" button 1) on "A".**

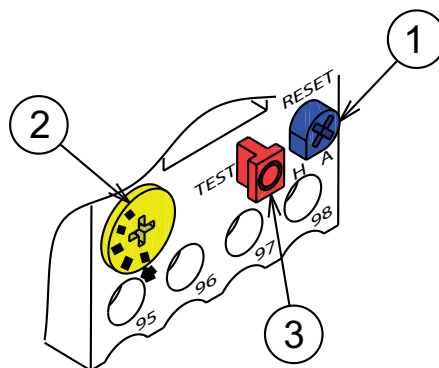

20073932

Fig. 9

4.4 Operating position



- The burner is designed to operate only in positions 1, 2, 3 and 4 (Fig. 11).
- Installation 1 is preferable, as it is the only one that allows the maintenance operations as described in this manual.
- Installations 2, 3 and 4 permit operation but make maintenance and inspection of the combustion head more difficult.



- Any other position could compromise the correct operation of the appliance.
- Installation 5 is prohibited for safety reasons.

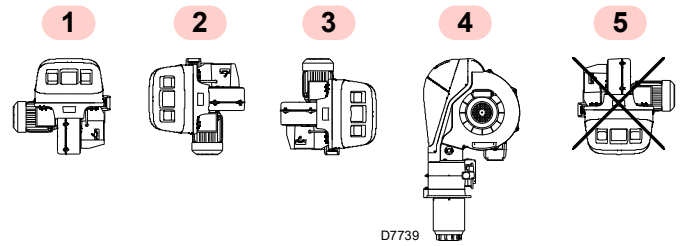

Fig. 11

4.5 Preparing the boiler

4.5.1 Boring the boiler plate

Pierce the closing plate of the combustion chamber, as in Fig. 12. The position of the threaded holes can be marked using the thermal insulation screen supplied with the burner.

4.5.2 Blast tube length

The length of the blast tube must be selected according to the indications provided by the manufacturer of the boiler, and in any case it must be greater than the thickness of the boiler door complete with its fettling.

The refractory can have a conical shape (minimum 60°).

For boilers with front flue passes 1)(Fig. 13) or flame inversion chamber, a protection in refractory material 5) must be inserted between the boiler fettling 2) and the flame funnel 4).

This protective fettling must not compromise the extraction of the blast tube.

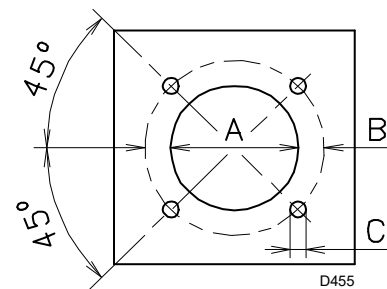

Fig. 12

mm	A	B	C
RS 310/M MZ	335	452	M18
RS 410/M MZ	335	452	M18
RS 510/M MZ	335	452	M18
RS 610/M MZ	350	452	M18

Tab. G

4.6 Securing the burner to the boiler



Prepare a suitable lifting system using rings 3)(Fig. 13).

- Fit the heat insulation supplied onto the blast tube 4)(Fig. 13).
- Fit the entire burner onto the boiler hole prepared previously (Fig. 12), and fasten with the screws supplied.



The seal between burner and boiler must be airtight.

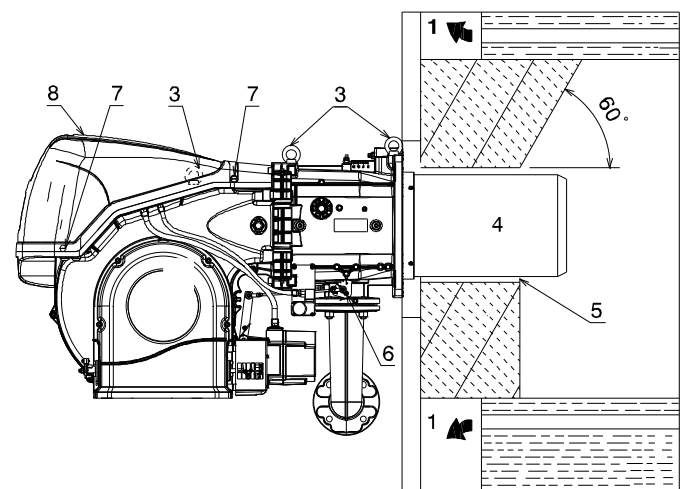

Fig. 13

4.7 Access to head internal part

The burner leaves the factory set for opening to the left, therefore maintaining the pin 1)(Fig. 14) in the housing.

To open the burner towards the left, proceed as follows:

- A** Remove the screw 6) releasing the tie-rod 7)(Fig. 14);
- B** Disconnect the plug/socket 9)(Fig. 14) of the maximum gas pressure switch;
- C** Remove the screws 2);
- D** Open the burner to a maximum of 100-150 mm by rotating around the hinge and release the cables of the probe 5) and electrode 11);
- E** Fully open the burner as in Fig. 14;
- F** Undo the screw 4) with pressure test point;
- G** Release the head by lifting it from its housing 3), then take out the combustion head.



WARNING

To open the burner from the opposite side, before removing the pin 1)(Fig. 14), make sure that the 4 screws 2) are tight. Then shift the pin 1) to the opposite side, only then is it possible to remove the screws 2); then proceed as described in point C.

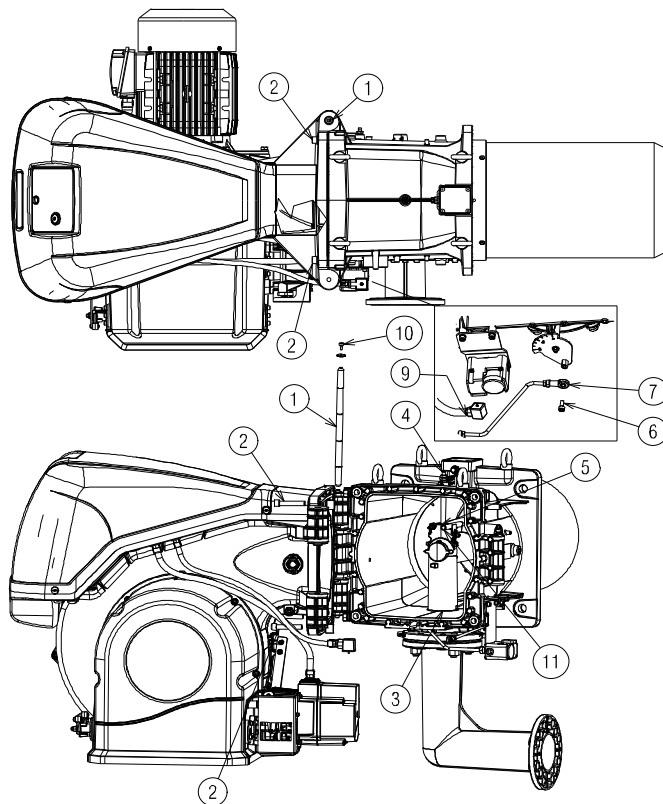

20072028

Fig. 14

4.8 Probe-electrode position



WARNING

Check that the probe and the electrode are placed as in Fig. 15, according to the dimensions indicated.

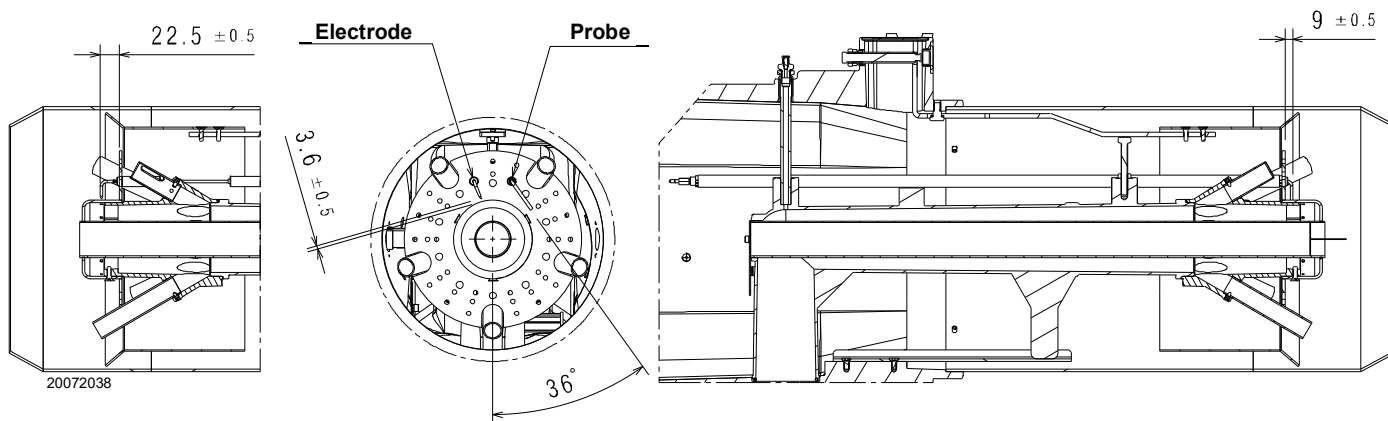

20072038

Fig. 15

4.9 Gas butterfly valve

If necessary, replace the gas butterfly valve. The correct position is indicated in Fig. 16.

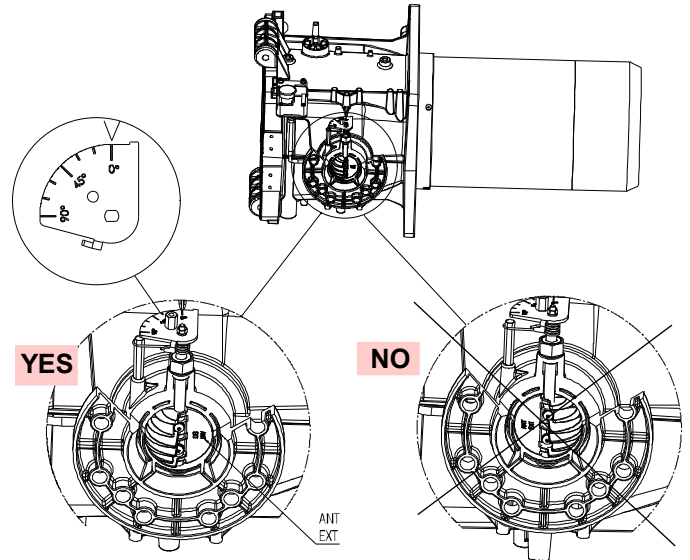

20078516

Fig. 16

4.10 Combustion head adjustment

Rotate the screw 1) until the notch you have found corresponds with the front surface of the screw itself.

The combustion head is opened by turning the screw 1) anti-clockwise.

The combustion head is closed by turning the screw 1) clockwise (Fig. 17).

Central air adjustment:

The factory setting is shown in Tab. H

Burner	RS 310	RS 410	RS 510	RS610
Set-point	7	4	7	7

Tab. H



WARNING

Normally the calibrations indicated in Tab. H should not be changed.

In the event that the specific application requires a particular adjustment, it is possible to change the central air flow rate using the ring nut 4)(Fig. 18). To carry out this operation loosen the screws 5)(Fig. 18) and move the ring nut 4)(Fig. 18). When finished, lock the screws 5) again (Fig. 18).

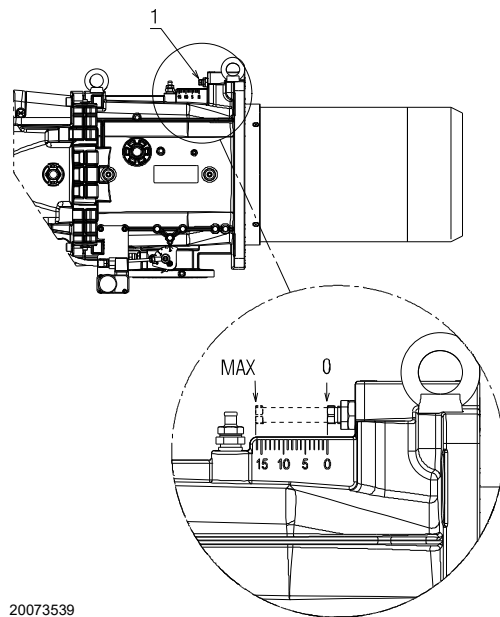

20073539

Fig. 17

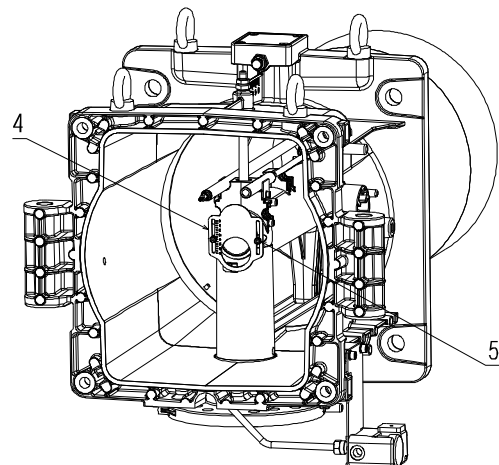

20077011

Fig. 18

Below is a diagram (Fig. 19) that shows the recommended adjustment of the combustion head.

NOTE:
Depending on the specific application, the adjustment can be modified.

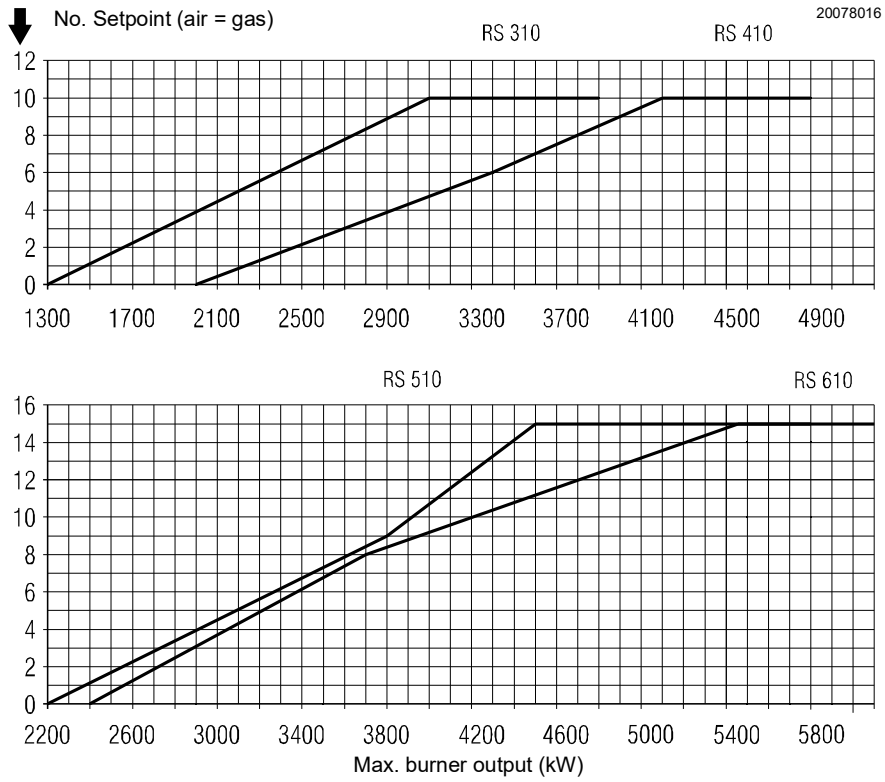

Fig. 19

4.11 Gas feeding



Explosion danger due to fuel leaks in the presence of a flammable source.

Precautions: avoid knocking, attrition, sparks and heat.

Make sure the fuel interception tap is closed before performing any operation on the burner.



The fuel supply line must be installed by qualified personnel, in compliance with current standards and laws.

4.11.1 Gas feeding line (Example) - Please refer to the gas train documentation for more information

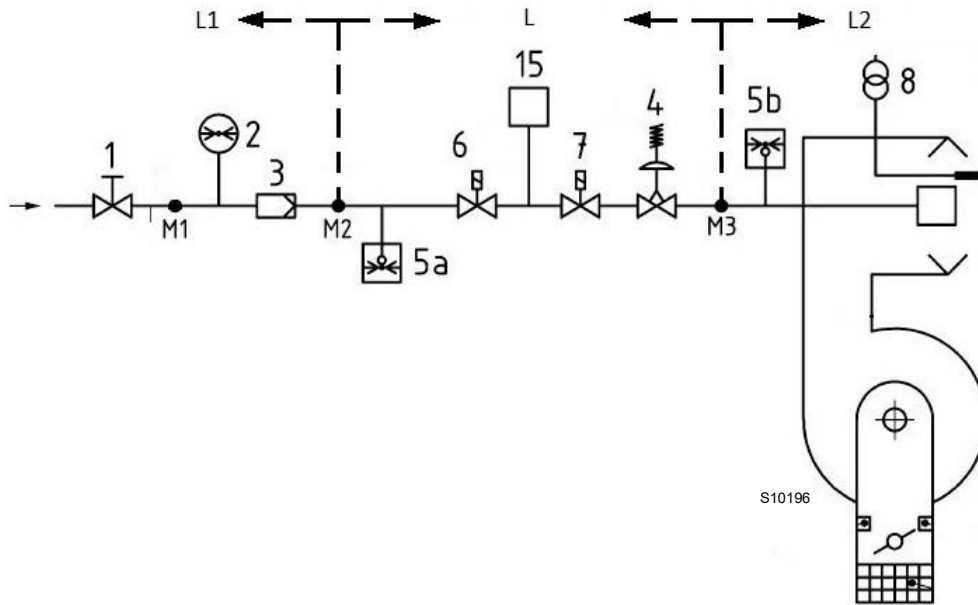

Fig. 20

Key (Fig. 20)

- 1 Manually operated shut-off valve
- 2 Pressure gauge
- 3 Filter
- 4 Governor
- 5a Low pressure protection device
- 5b Maximum gas pressure switch
- 6 1st safety shut-off device
- 7 2nd safety shut-off device
- 8 Ignition device
- 15 Valve leak detection control system
- L Gas train (supplied separately)
- L1 Responsibility of the installer
- L2 Burner
- M1 Pressure test point
- M2 Pressure test point
- M3 Pressure test point

4.11.2 Gas train

Approved according to standard EN 676 and provided separately from the burner.



Make sure that the gas train is properly installed by checking for any fuel leaks.

4.11.3 Gas train installation



DANGER

Disconnect the electrical power using the main switch.



Check that there are no gas leaks.



Pay attention when handling the train: danger of crushing of limbs.



The operator must use the required equipment during installation.

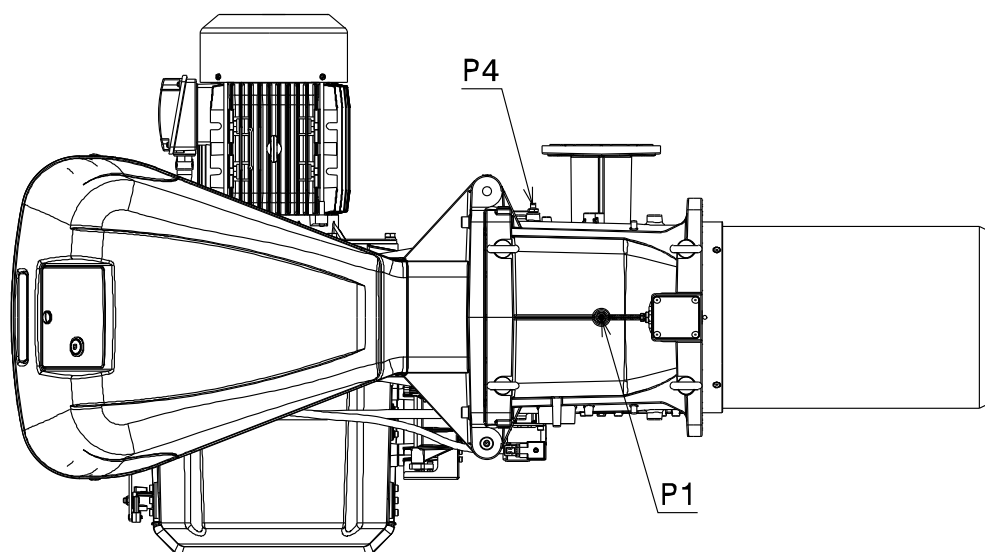

20072044

Fig. 21

4.11.4 Gas pressure

Tab. I indicates the minimum pressure drops along the gas supply line, depending on the maximum burner output.

The values shown in Tab. I refer to:

- Natural gas G 20 NCV 9.45 kWh/Sm³ (8.2 Mcal/Sm³)
- Natural gas G 25 NCV 8.13 kWh/Sm³ (7.0 Mcal/Sm³)

Column 1

Combustion head pressure drop.

Gas pressure measured at the test point P1)(Fig. 21), with:

- Combustion chamber at 0 mbar;
- Burner working at maximum output;
- Combustion head adjusted as in page 19.

Column 2

Pressure loss at gas butterfly valve 4)(Fig. 27 on page 28) with maximum opening: 90°.

Calculate the approximate maximum output of the burner in this way:

- subtract the combustion chamber pressure from the gas pressure measured at test point P1)(Fig. 21).
- Find, in the table Tab. I related to the burner concerned, the pressure value closest to the result of the subtraction.
- read the corresponding output on the left.

Example for RS 410/M MZ with G20 natural gas:

Maximum output operation

$$\begin{aligned} \text{Gas pressure at test point P1)(Fig. 21)} &= 46.7 \text{ mbar} \\ \text{Pressure in combustion chamber} &= 5 \text{ mbar} \\ 46.7 - 5 &= 41.7 \text{ mbar} \end{aligned}$$

A pressure of 41.7 mbar, column 1, corresponds in the table Tab. I to an output of 4900 kW.

This value serves as a rough guide; the effective output must be measured at the gas meter.

To calculate the required gas pressure at test point P1)(Fig. 21), set the MAX output required from the burner operation:

- find the nearest output value in the table Tab. I for the burner in question.
- read, on the right (column 1), the pressure at the test point P1)(Fig. 21).
- Add this value to the estimated pressure in the combustion chamber.

Example for RS410/M MZ with G20 natural gas:

Required burner maximum output operation: 4900 kW

$$\begin{aligned} \text{Gas pressure at an output of 4900 kW} &= 41.7 \text{ mbar} \\ \text{Pressure in combustion chamber} &= 5 \text{ mbar} \\ 41.7 + 5 &= 46.5 \text{ mbar} \end{aligned}$$

Pressure required at test point P1)(Fig. 21).

	kW	1 Δp (mbar)		2 Δp (mbar)	
		G 20	G 25	G 20	G 25
RS 310/M MZ	1300	3,4	5,1	0,1	0,1
	1560	5,5	8,2	0,5	0,7
	1820	7,8	11,6	1,6	2,4
	2080	10,3	15,4	2,7	4,0
	2340	13,0	19,4	3,9	5,8
	2600	15,9	23,7	5,0	7,5
	2860	18,9	28,2	6,2	9,3
	3120	22,2	33,1	7,5	11,2
	3380	25,7	38,3	8,7	13,0
	3640	29,3	43,7	10,0	14,9
RS 410/M MZ	3900	33,2	49,5	11,4	17,0
	2000	13,8	20,6	2,4	3,6
	2290	14,5	21,6	3,6	5,4
	2580	15,7	23,4	4,9	7,3
	2870	17,4	26,0	6,3	9,4
	3160	19,5	29,1	7,7	11,5
	3450	22,1	33,0	9,1	13,6
	3740	25,1	37,4	10,5	15,7
	4030	28,6	42,7	12,0	17,9
	4320	32,5	48,5	13,6	20,3
RS 510/M MZ	4610	36,9	55,1	15,1	22,5
	4900	41,7	62,2	16,8	25,1
	2200	15,7	23,4	3,3	4,9
	2540	16,3	24,3	4,8	7,2
	2880	17,4	26,0	6,3	9,4
	3220	19,2	28,6	8,0	11,9
	3560	21,6	32,2	9,6	14,3
	3900	24,6	36,7	11,4	17,0
	4240	28,2	42,1	13,1	19,5
	4580	32,5	48,5	15,0	22,4
RS 610/M MZ	4920	37,3	55,7	16,9	25,2
	5260	42,8	63,9	18,8	28,0
	5600	48,9	73,0	20,8	31,0
	2400	10,3	15,4	4,1	6,1
	2790	13,8	20,6	5,9	8,8
	3180	17,8	26,6	7,8	11,6
	3570	22,2	33,1	9,7	14,5
	3960	27,0	40,3	11,7	17,5
	4350	32,2	48,0	13,7	20,4
	4740	37,9	56,5	15,9	23,7
5130	43,9	65,5	18,1	27,0	
5520	50,4	75,2	20,3	30,3	
5910	57,3	85,5	22,7	33,9	
6300	64,6	96,4	25,1	37,4	

Tab. I



Data of head thermal power and gas pressure refer to operation with gas butterfly valve fully open (90°).

4.12 Electrical wiring

Notes on safety for the electrical wiring



- The electrical wiring must be carried out with the electrical supply disconnected.
- Electrical wiring must be made in accordance with the regulations currently in force in the country of destination and by qualified personnel. Refer to the wiring diagrams.
- The manufacturer declines all responsibility for modifications or connections different from those shown in the wiring diagrams.
- Check that the electrical supply of the burner corresponds to that shown on the identification label and in this manual.
- The burners have been set for intermittent operation. This means it should compulsorily be stopped at least once every 24 hours to enable the flame control to check its own efficiency at start-up. Normally the boiler's thermostat/pressure switch ensures that the burner stops. If this is not the case, a time switch (IN) should be fitted in series to provide for burner shutdown at least once every 24 hours. Refer to the wiring diagrams.
- The electrical safety of the device is obtained only when it is correctly connected to an efficient earthing system, made according to current standards. It is necessary to check this fundamental safety requirement. In the event of doubt, have the electrical system checked by qualified personnel. Do not use the gas tubes as an earthing system for electrical devices.
- The electrical system must be suitable for the maximum power absorption of the device, as indicated on the label and in the manual, checking in particular that the section of the cables is suitable for that level of power absorption.
- For the main power supply of the device from the electricity mains:
 - do not use adapters, multiple sockets or extensions;
 - use a multiple pole switch with at least a 3 mm gap between the contacts (overvoltage category III), as envisaged by the present safety standards.
- Do not touch the device with wet or damp body parts and/or in bare feet.
- Do not pull the electric cables.

Before carrying out any maintenance, cleaning or checking operations:



Disconnect the electrical supply from the burner by means of the main system switch.



Turn off the fuel interception tap.



Avoid condensate, ice and water leaks from forming.

If the cover is still present, remove it and proceed with the electrical wiring according to the wiring diagrams.

Use flexible cables in compliance with the EN 60 335-1 standard.

4.12.1 Supply cables and external connections passage

All the cables to be connected to the burner must be threaded through cable grommets. The use of the cable grommets can take various forms; by way of example see Fig. 22.

Key (Fig. 22)

- 1 Electrical supply - Bore for M32
- 2 Consents / Safety devices - Bore for M20
- 3 Minimum gas pressure switch - Bore for M20
- 4 VPS gas valve leak detection control kit- Bore for M20
- 5 Gas train - Bore for M20
- 6 Available - Bore for M20
- 7 Available - Bore for M16

Cable grommets used in the factory:

- A - Fan motor
- B - Maximum gas pressure switch
- C - Air/gas servomotor

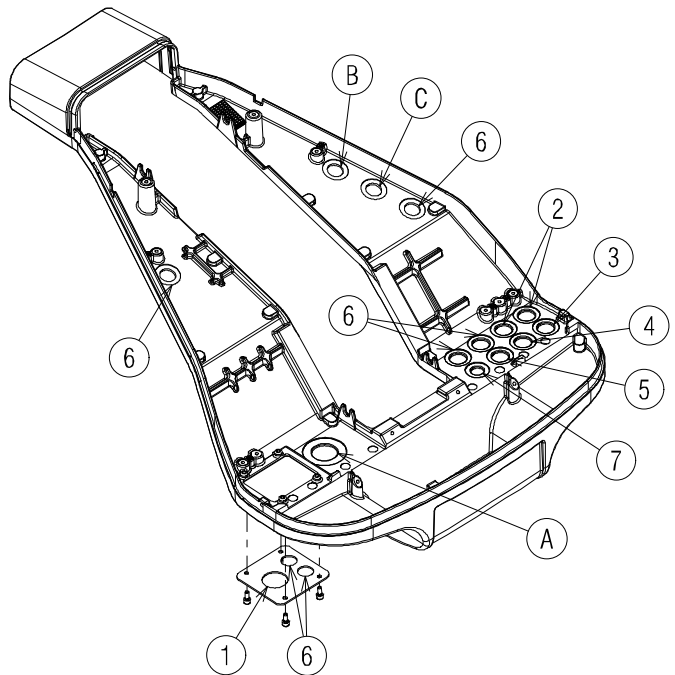

20073934

Fig. 22



After carrying out maintenance, cleaning or checking operations, reassemble the cover and all the safety and protection devices of the burner.

5 Start-up, calibration and operation of the burner

5.1 Notes on safety for the first start-up



WARNING

The first start-up of the burner must be carried out by qualified personnel, as indicated in this manual and in compliance with the standards and regulations of the laws in force.



WARNING

Check the correct working of the adjustment, command and safety devices.



WARNING

Before starting up the burner, refer to section see "Safety test - with no gas supply" on page 34.

5.2 Adjustments prior to ignition

Combustion head adjustment is already described on page 19.

In addition, the following adjustments must also be made:

- open manual valves upline from the gas train.
- Adjust the minimum gas pressure switch to the start of the scale.
- Adjust the maximum gas pressure switch to the end of the scale.
- Adjust the air pressure switch to the start of the scale.
- Purge the air from the gas line. We recommend using a plastic tube routed outside the building and to purge air until gas is smelt.
- Fit a U-type pressure gauge or a differential pressure gauge (Fig. 23), with socket (+) on the gas pressure of the pipe coupling and (-) in the combustion chamber. The manometer readings are used to calculate MAX burner output using the Tab. I.
- Connect two lamps or testers to the two gas line solenoids to check the exact moment in which voltage is supplied. This operation is unnecessary if each of the two solenoids is equipped with a pilot light that signals voltage passing through.



CAUTION

Before starting up the burner, it is good practice to adjust the gas train so that ignition takes place in conditions of maximum safety, i.e. with gas delivery at the minimum.

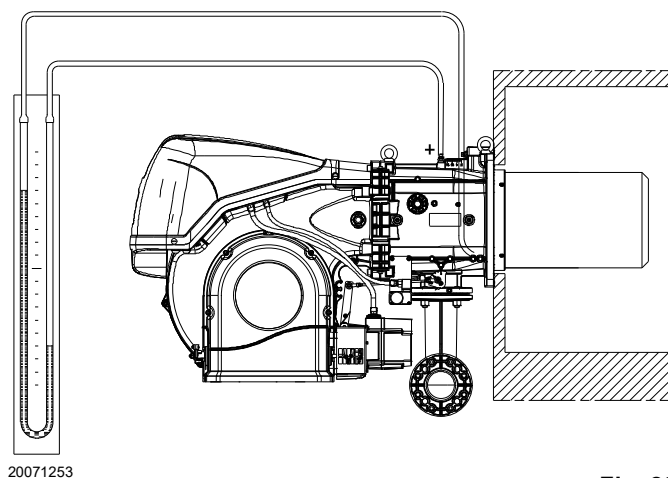

Fig. 23

5.3 Servomotor adjustment

The servomotor (Fig. 24) provides simultaneous adjustment for the air damper, by means of the adjustable profile cam and the gas butterfly valve. Completes a rotation of 90° in 30 s.

After the adjustment made in the factory to its 6 cams to allow an initial ignition. Check that they are as shown below. In the event of a modification, follow what is described below for each cam:

Cam I (RED): 90° (The same for all models)
Limits the rotation towards the maximum.



In the event of a variation, absolutely do not adjust beyond 90°.

Cam II (BLUE): 0° (The same for all models)
Limits the rotation towards the minimum.

With the burner off the air damper and the gas butterfly valve should be closed: 0°

It is recommended that no adjustments are made.

Cam III (ORANGE): (See Tab. J)
Adjusts the ignition position and MIN. output

Cam IV-V-VI (YELLOW/BLACK/GREEN):
Do not use, they have no effect on the operation of the burner.

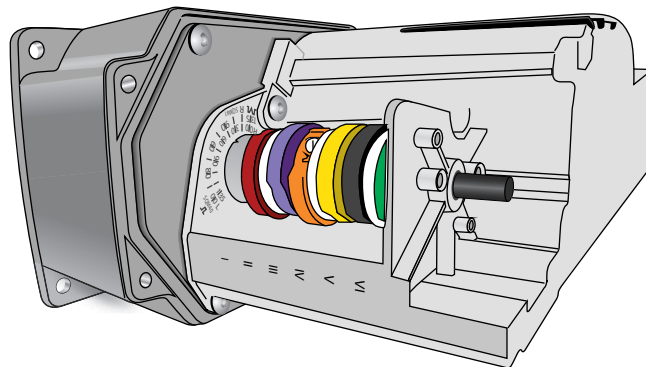

20074577

Fig. 24

CALIBRATION	RS 310/M	RS 410/M	RS 510/M	RS 610/M
CAM 3 (ORANGE)	5°	5°	5°	15°

Tab. J

5.4 Burner start-up

Turn off the thermostats/pressure switches and check the light signal 2) comes on (Fig. 5 on page 12).

Put the selector 1)(Fig. 25) in position "MAN".

Start of the fan motor. As the burner is not fitted with a device to check the sequence of the phases, the motor rotation may be incorrect.

As soon as the burner starts up, go in front of fan motor cooling fan and check it is rotating anticlockwise or else in the direction of the arrow shown in the diagram (burner description).

If this is not the case:

- put the switch 1) of Fig. 25 to "0" and wait for the flame control carries out the switching off phase;



disconnect the burner's electrical supply, since this operation should be carried out in the absence of the electrical supply;

- Invert the phases on the three-phase power supply;
- repeat the start-up procedure.



Make sure that the lights or testers connected to the solenoids, or the pilot lights on the solenoids themselves, indicate that no voltage is present. If voltage is present, stop the burner **immediately** and check the electrical wiring.

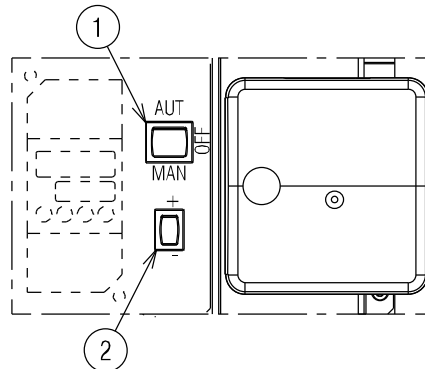

20073937

Fig. 25

5.5 Burner ignition

The burner should light after having performed the above steps.

If the motor starts up, but the flame does not appear and the flame control goes into lockout, reset it and wait for a new ignition attempt.

Two types of burner failure may occur:

- **Flame control lockout:** if the flame control push-button (red led) 2)(Fig. 5 on page 12) lights up, it indicates that the burner is in lockout. Refer to the flame control diagnostics for the causes of the lockout. release by pressing the push-button 2)(Fig. 5 on page 12). See flame control reset.
- **Motor lockout because of thermal relay intervention:** because of an erroneous calibration of the thermal relay or problems with the motor or the main power supply. Release by pressing the button on thermal relay, see section "Calibration of the thermal relay" on page 15.

If ignition is still not achieved, it may be that gas is not reaching the combustion head within the safety time period of 3 seconds. In this case increase gas ignition delivery.

The arrival of gas at the pipe coupling is indicated by the U-type pressure gauge (Fig. 23).

Once the burner has fired, now proceed with global calibration operations.

5.6 Air / fuel adjustment

The air/fuel synchronisation is carried out using a servomotor 1)(Fig. 26) which, when connected directly to the air dampers, acts on the gas butterfly valve by means of an adjustable profile cam 2) and suitable leverage.



**WARNING!
MOVING PARTS**



DANGER: CRUSHING OF LIMBS

It is advisable, to reduce the loss and for a wide calibration field, to adjust the servomotor to the maximum of the output used, the nearest possible to the maximum opening (90°).

The choking of the air, taking into account the maximum combustion output, takes place by varying the adjustment of the combustion head (see "Combustion head adjustment" on page 19).

On the gas butterfly valve, fuel step according to the burner output required, with servomotor completely open, is carried out by the pressure stabiliser placed on the train.

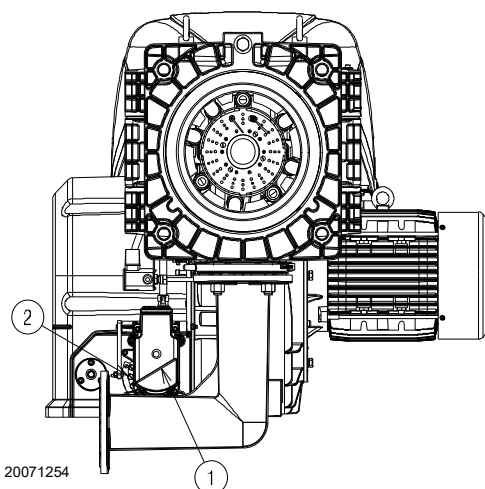

20071254

Fig. 26

5.6.1 Burner adjustment

The optimum adjustment of the burner requires an analysis of flue gases at the boiler outlet.

Adjust in sequence:

- 1 - Output upon ignition
- 2 - MAX output
- 3 - MIN output
- 4 - Intermediate outputs between Min. and Max.
- 5 - Air pressure switch
- 6 - Maximum gas pressure switch
- 7 - Minimum gas pressure switch

5.6.2 Output upon ignition



WARNING

For safety purposes and correct product operation, the ignition output, if it is adjustable, must be carried out by authorized personnel and in compliance with the standards and regulations of the laws in force.

Air adjustment

The air is adjusted by varying the angle of cam III)(Fig. 24) and by using the selector 2)(Fig. 25). To adjust the cam of the servomotor, see Fig. 28 A).

5.6.3 Maximum output

The MAX output must be set within the firing rate indicated in Fig. 2 on page 9.

In the above instructions we left the burner running at the MIN output. Now press the "increase output" button 2)(Fig. 25 on page 27), and keep it pressed until the servomotor has opened the air damper and the gas butterfly valve.

Adjustment of gas delivery

Measure the gas delivery on the gas meter.

A rough indication can be obtained from Tab. I on page 23, just read the gas pressure on the "U" pressure gauge (see Fig. 23 on page 25) and follow the indications.

- If delivery needs to be reduced, diminish outlet gas pressure; if it is already very low, slightly close the VR adjustment valve.
- If delivery needs to be increased, increase the adjuster outlet gas pressure.

Air adjustment

The air is adjusted by varying the angle of cam I)(Fig. 24 on page 26) and by using the selector 2)(Fig. 25 on page 27). To adjust the cam of the servomotor, see Fig. 28 A).

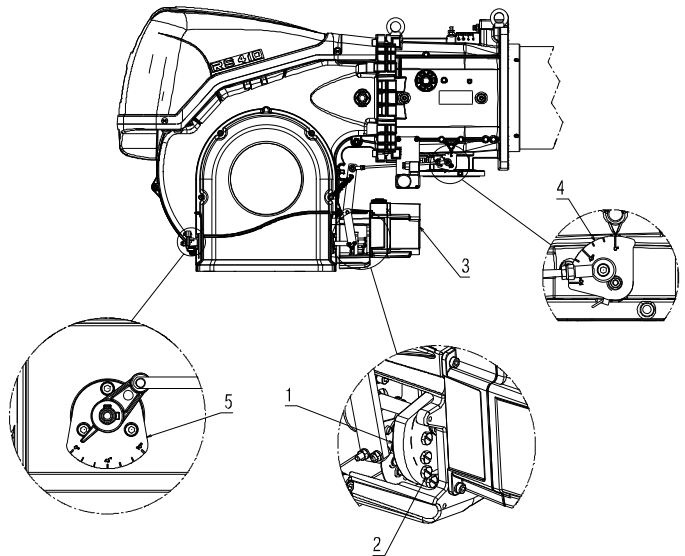

20073575

Fig. 27

Key (Fig. 27)

- 1 Cam
- 2 Adjustment screws
- 3 Servomotor
- 4 Graduated sector for gas butterfly valve
- 5 Air damper graduated sector

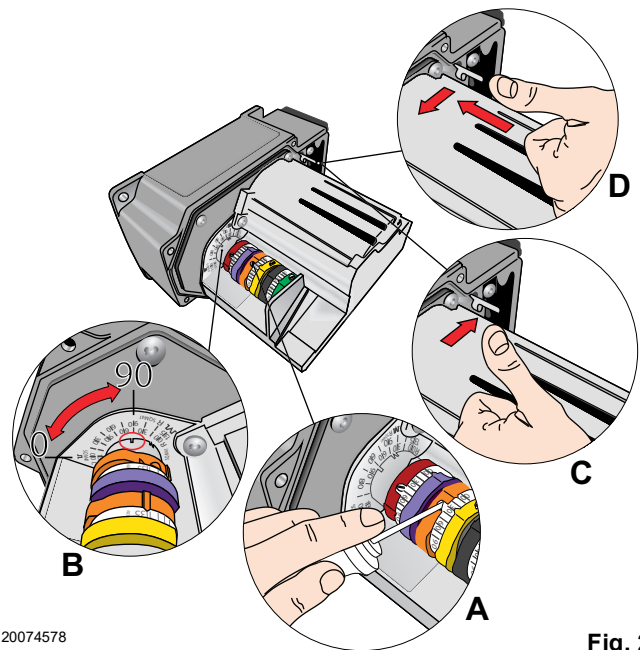

20074578

Fig. 28

5.6.4 Minimum output

Min output must be selected within the firing rate range shown on Fig. 2 on page 9.

Press button 2)(Fig. 25 on page 27) "Diminishing output" and keep it pressed until the servomotor regains (Fig. 28 B) the adjustment made in the factory: See Tab. J on page 26 and as a consequence adjusting the air damper 5) and the gas butterfly valve 4)(Fig. 27 on page 28).

Adjustment of gas delivery

Progressively adjust the end profile of the mechanical cam 1)(Fig. 27 on page 28), using the screws 2).

For example, calibrate the minimum output to 800 kW, check the emissions and if necessary increase or decrease the opening of the air damper (see "" on page 28). Bring the output to 800 kW using the screws 2) of the mechanical cam (Fig. 27 on page 28) and check the emissions.

Air adjustment

The regulation of the air is carried out using the angle of the cam III) of the servomotor (Fig. 24 on page 26) and by using the selector 2)(Fig. 25 on page 27). To adjust the cam of the servomotor, see Fig. 28 A).

NOTE:

The servomotor follows the adjustment of cam III only when the angle of the cam is reduced. If it is necessary to increase the angle of the cam, you must first increase the angle of the servomotor by means of the "output increase" key, then increase the angle of cam III, and finally bring the servomotor to the position of MIN output, with the "Output reduction" key.

To adjust the cam III, see Fig. 28 A) e B).

5.6.5 Intermediate outputs

Air adjustment

No adjustment is required

Adjustment of gas delivery

After adjusting the maximum and minimum output of the burner, carry out air adjustment on higher intermediate positions of the servomotor. The passage from one position to the next one is obtained by pressing the button 2) on the symbol (+) or (-)(Fig. 25 on page 27). For a brief period press the button 2)(Fig. 25 on page 27) "Output increase" so that the servomotor rotates by about 20°, see servomotor graduated index Fig. 28 B) and the air damper graduated index 5)(Fig. 27 on page 28).

Screw or unscrew the screw 2) of the mechanical cam (Fig. 27 on page 28) to increase or decrease the gas output so as to adjust it to the corresponding air output, to obtain optimal combustion.

Proceed in the same way with the other screws.



Take care that the cam profile variation is progressive.

Switch off the burner using the switch 1)(Fig. 25), OFF position, release the mechanical cam I)(Fig. 27) to separate the gears of the servomotor, pressing and shifting downwards the button 3)(Fig. 28 D) and check a few times, by rotating the mechanical cam I)(Fig. 27) manually backwards and forwards, that the movement is smooth and without any hindrance.



It is recommended that the mechanical cam I)(Fig. 27 on page 28) be bound again to the servomotor by shifting button 3)(Fig. 28 C) upwards.

As far as is possible, try not to move those screws at the ends of the mechanical cam that were previously adjusted for the opening of the gas butterfly valve to MAX and MIN output.

NOTE:

Once you have finished adjusting the "MAX - MIN - INTERMEDIATE" outputs, check ignition once again: noise emission at this stage must be identical to the following stage of operation. If you notice any sign of pulsations, reduce the ignition stage delivery.

5.7 Pressure switch adjustment

5.7.1 Air pressure switch - check CO

Adjust the air pressure switch (Fig. 29) after performing all other burner adjustments with the air pressure switch set to the start of the scale.

With the burner operating at min. output, increase adjustment pressure by slowly turning the relative knob clockwise until the burner locks out.

Then turn the knob anti-clockwise by about 20% of the set point and repeat burner starting to ensure it is correct.

If the burner locks out again, turn the knob anticlockwise a little bit more.



In conformity with the standard, the air pressure switch must prevent the air pressure falling below 80% of the adjusted value and the CO in the flue gases exceeding 1% (10,000 ppm).

To check this, insert a combustion analyser into the chimney, slowly close the fan suction inlet (for example with cardboard) and check that the burner locks out, before the CO in the fumes exceeds 1%.



Connecting the air pressure switch in differential mode, the burner will no longer be certified according to the EN 676 standard.

5.7.2 Maximum gas pressure switch

Adjust the maximum gas pressure switch (Fig. 30) after making all other burner adjustments with the maximum gas pressure switch set to the end of the scale.

To calibrate the maximum gas pressure switch, open the tap and then connect a pressure gauge to its pressure test point.

The maximum gas pressure switch must be regulated to a value no higher than 30% of the measurement read on the gauge when the burner is working at maximum output.

After making the adjustment, remove the pressure gauge and close the tap.

5.7.3 Minimum gas pressure switch

The purpose of the minimum gas pressure switch is to prevent the burner from operating in an unsuitable way due to too low gas pressure.

Adjust the minimum gas pressure switch (Fig. 31) after having adjusted the burner, the gas valves and the gas train stabiliser. With the burner operating at maximum output:

- install a pressure gauge downstream of the gas train stabiliser (for example at the gas pressure test point on the burner combustion head);
- choke slowly the manual gas cock until the pressure gauge detects a decrease in the pressure read of about 0.1 kPa (1 mbar). In this phase, verify the CO value which must always be less than 100 mg/kWh (93 ppm).
- Increase the adjustment of the gas pressure switch until it intervenes, causing the burner shutdown;
- remove the pressure gauge and close the cock of the gas pressure test point used for the measurement;
- open completely the manual gas cock.



1 Kpa = 10 mbar

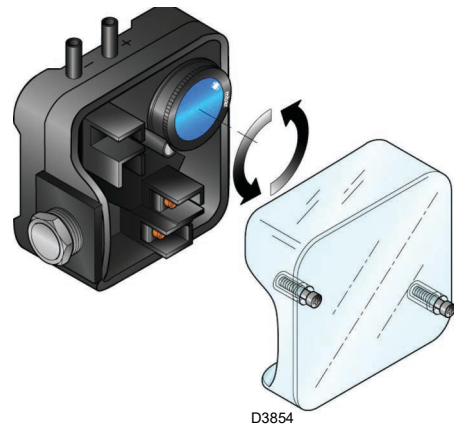

Fig. 29

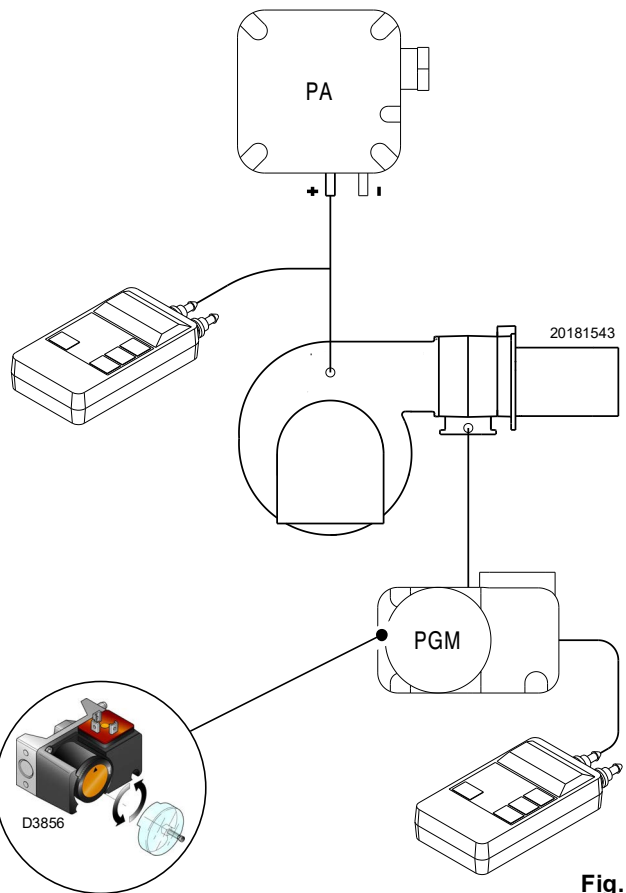

Fig. 30

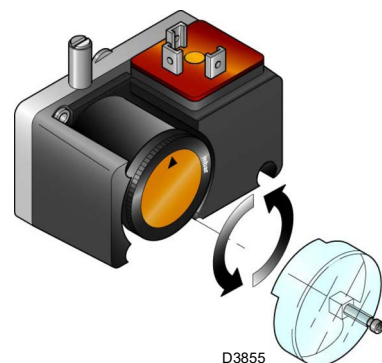

Fig. 31

5.8 Operation sequence of the burner

5.8.1 Burner start-up

- T0:** 0 s. - Closure of thermostat/pressure switch TL.
- T1:** 2 s. - Start of flame control programme.
Fan motor starts up, servomotor starts up, the pre-purging phase starts. The servomotor rotates to the right by 90°, i.e. until the contact intervenes on the cam 1)(Fig. 24 on page 26).
- T2:** 34 s. - The air damper arrives at the MAX. output position.
- T3:** 58 s. - The servomotor rotates towards the left until the angle set on the cam 3)(Fig. 24 on page 26).
- T4:** The air damper arrives on the MIN. power position or ignition position (Tab. K).
- T5:** 89 s. - The ignition electrode strikes a spark. The safety valve VS opens, along with the adjustment valve VR. The flame is ignited at a low output level, point A. Delivery is then progressively increased, with the valve VR opening slowly up to MIN. output, point B.
- T6:** 91 s. - The spark goes out.
- T7:** 99 s. - The flame control value starting cycle ends..

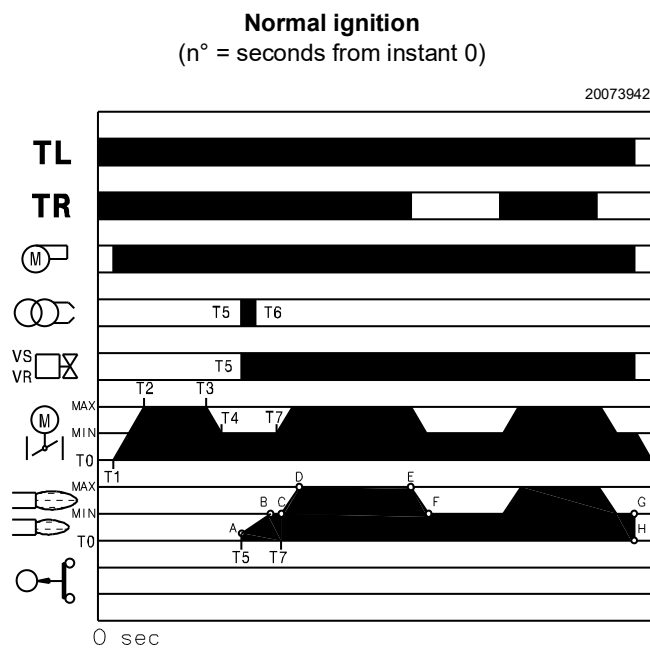

Fig. 32

5.8.2 Operation

Burner without the RWF ... output regulator (See kit)

Once the start-up cycle is completed, the servomotor command moves on to the TR thermostat/pressure switch that controls the pressure or the temperature in the boiler, point C. (The flame control continues to check the presence of the flame and the correct position of the air and gas maximum pressure switches).

- If the temperature or the pressure is low so the thermostat/pressure switch TR is closed, the burner progressively increases the output up to the MAX value (section C-D).
- If subsequently the temperature or pressure increases until TR opens, the burner progressively decreases its output to the MIN value (section E-F). The sequence repeats endlessly.
- The burner locks out when the heat request is less than the heat supplied by the burner at MIN output, (section G-H). The TL thermostat/pressure switch opens, and the servomotor returns to angle 0° limited by the contact of the cam 2)(Fig. 24 on page 26). The air damper closes completely to reduce heat losses to a minimum.

For every change of output, the servomotor will automatically change the gas output (butterfly valve), the air output (fan damper) and the air pressure.

Burner with the RWF ... output regulator (See kit)

See manual enclosed with the adjuster.

5.8.3 Ignition failure

If the burner does not fire, it goes into lockout within 3 seconds after the gas valve opens or 91 seconds after the TL closes.

5.8.4 Burner flame goes out during operation

If the flame should go out during operation, the burner will lockout within 1s.

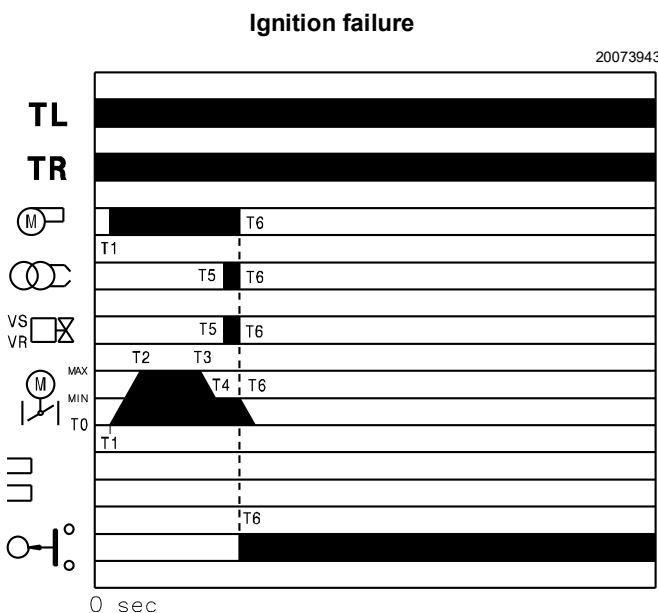

Fig. 33

MODEL	T4
RS 310/M	89
RS 410/M	89
RS 510/M	81
RS 610/M	85

Tab. K

5.9 Burner start-up cycle diagnostics

During start-up, indication is according to the colour code table (Tab. L).

Sequences	Colour code
Pre-purging	●●●●●●●●●●
Ignition phase	●○●○●○●○●○●○
Operation, flame OK	□□□□□□□□□□
Operation with weak flame signal	□○□○□○□○□○□○
Electrical supply below ~ 170V	●▲●▲●▲●▲●▲●▲
Lockout	▲▲▲▲▲▲▲▲▲▲
Extraneous light	▲□▲□▲□▲□▲□▲□

Tab. L

Key (Tab. L):

▲ Off ○ Yellow ● Green □ Red

5.9.1 Resetting of flame control and diagnostics use

The flame control features a diagnostics function through which any causes of malfunctioning are easily identified (indicator: **RED LED**).

To use this function, you must wait at least 10 seconds once it has entered the safety condition (**lockout**), and then press the reset button.

The flame control generates a sequence of pulses (1 second apart), which is repeated at constant 3-second intervals.

Once you have seen how many times the light blinks and identified the possible cause, the system must be reset by holding the button down for 1 - 3 seconds.

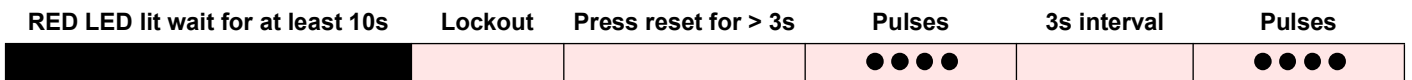

Tab. M

The methods that can be used to reset the flame control and use diagnostics are given below.

5.9.2 Flame control reset

To carry out the flame control reset, proceed as follows:

- Hold the button down for between 1 and 3 seconds. The burner restarts after a 2-second pause once the button is released. If the burner does not restart, you must make sure the limit thermostat is closed.

5.9.3 Visual diagnostics

Indicates the type of burner malfunction causing lockout. To visualise the diagnostics proceed as follows:

- Hold the button down for more than 3 seconds once the red LED (burner lockout) remains steadily lit. A yellow light blink to tell you the operation is done.
- Release the button once the light has blinked. The number of blinks indicates the reason for the malfunctioning (refer to the coding in Tab. S on page 37).

5.9.4 Software diagnostics

Gives an analysis of the life of the burner, through optical connections with a PC showing the working hours, number and types of lockout, flame control serial number etc...

To view diagnostics, proceed as follows:

- Hold the button down for more than 3 seconds once the red LED (burner lockout) remains steadily lit. A yellow light blink to tell you the operation is done.
- Release the button for 1 second and then press again for over 3 seconds until the yellow light blinks again.
- Once the button is released, the red LED will flash intermittently with a higher frequency: only now can the optical link be activated.

Once the operations are done, the flame control's initial status must be restored using the resetting procedure described above.

PRESSURE ON THE BUTTON	STATE OF FLAME CONTROL
From 1 to 3 seconds	Reset of the flame control without visualisation of the visual diagnostics.
More than 3 seconds	Visual diagnostics of the lockout condition: (LED blinks at 1-second intervals).
More than 3 seconds starting from the condition of visual diagnostics	Software diagnostics, with the help of optical interface and PC (possibility to visualise the working hours, irregularities, etc.)

Tab. N

The sequence of led pulses issued by the flame control identifies the possible types of malfunction, which are listed in the table Tab. S on page 37.

5.10 Normal operation / flame detection time

The flame control has a further function to guarantee the correct burner operation (signal: **GREEN LED** permanently on).

To use this function, wait at least ten seconds from the burner ignition and then press the flame control button for a minimum of 3 seconds.

After releasing the button, the GREEN LED starts flashing as shown in: Tab. O.

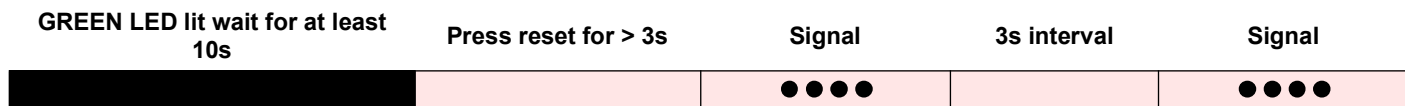

Tab. O

The pulses of the LED constitute a signal spaced by approximately 3 seconds.

The number of pulses will measure the probe detection time since the opening of gas valves, according to: Tab. P.

Signal	Flame detection time
1 blink ●	0.4 s
2 blinks ● ●	0.8 s
6 blinks ● ● ● ● ● ●	2.8 s

Tab. P

This is updated in every burner start-up.

Once read, the burner repeats the start-up cycle by briefly pressing the flame control button.



WARNING If the result is > 2 s, ignition will be retarded. Check the adjustment of the hydraulic brake of the gas valve, the air damper and the combustion head adjustment.

6 Maintenance

6.1 Notes on safety for the maintenance

The periodic maintenance is essential for the good operation, safety, yield and duration of the burner.

It allows you to reduce consumption and polluting emissions and to keep the product in a reliable state over time.



The maintenance interventions and the calibration of the burner must only be carried out by qualified, authorised personnel, in accordance with the contents of this manual and in compliance with the standards and regulations of current laws.

Before carrying out any maintenance, cleaning or checking operations:



Disconnect the electrical supply from the burner by means of the main system switch.



Turn off the fuel interception tap.



Wait for the components in contact with heat sources to cool down completely.

6.2 Maintenance programme

6.2.1 Maintenance frequency



The gas combustion system should be checked at least once a year by a representative of the manufacturer or another specialised technician.

6.2.2 Safety test - with no gas supply

To perform commissioning in safety conditions, it is very important to check correct wiring between gas valves and burner.

For this purpose, after checking that connections comply with the burner wiring diagrams, it is necessary to carry out a start-up cycle with gas cock closed (dry test).

- 1 The manual gas valve must be closed using the locking/unlocking device ("Lock-out / tag out" procedure).
- 2 Ensure that burner limit electrical contacts are closed
- 3 Ensure that minimum gas pressure switch contact is closed
- 4 Try to start the burner.

The start-up cycle must occur according to the following steps:

- Fan motor start-up for pre-purging
- Gas valve leak detection control, if applicable.
- Pre-purging completion
- Achievement of the ignition point
- Power supply of the ignition transformer
- Supply of gas valves.

As gas is closed, the burner cannot ignite and its flame control will switch to stop or safety lockout condition.

The actual supply of gas valves can be checked by inserting a tester; some valves are equipped with lights (or closing/opening position indicators) that activate as soon as they are powered.



IF POWER SUPPLY OF GAS VALVES OCCURS IN UNEXPECTED MOMENTS, DO NOT OPEN THE MANUAL VALVE, DISCONNECT POWER SUPPLY, CHECK WIRINGS, CORRECT THE ERRORS AND CARRY OUT THE WHOLE TEST AGAIN.

6.2.3 Checking and cleaning



The operator must use the required equipment during maintenance.

Combustion

The optimum calibration of the burner requires an analysis of the flue gases.

Significant differences with respect to the previous measurements indicate the points where most care should be exercised during maintenance.

Combustion head

Open the burner and make sure that all components of the combustion head are in good condition, not deformed by the high temperatures, free of impurities from the surroundings and correctly positioned.

Burner

Check that there are not excess wear or loosen screws. Clean the outside of the burner.

Fan

Check to make sure that no dust has accumulated inside the fan or on its blades, as this condition will cause a reduction in the air flow rate and provoke polluting combustion.

Boiler

Clean the boiler as indicated in its accompanying instructions in order to maintain all the original combustion characteristics intact, especially the flue gas temperature and combustion chamber pressure.

Flame presence check

The burner is fitted with an ionisation system to check that a flame is present (Fig. 34). The minimum current for flame control operation is 6 µA. The burner provides a much higher current, so controls are not normally required. However, if it is necessary to measure the ionisation current, disconnect the plug-socket on the ionisation probe cable and insert a direct current microammeter with a base scale of 100 µA. Carefully check polarities!

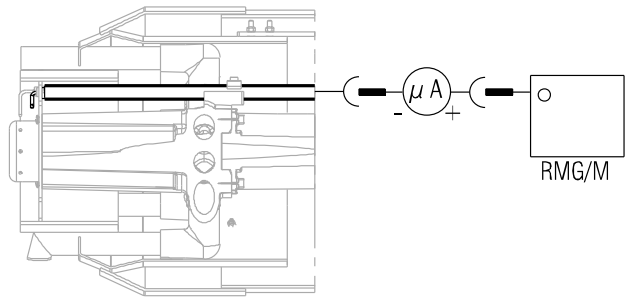

20073940

Fig. 34

Gas leaks

Make sure that there are no gas leaks on the pipe between the gas meter and the burner.

Gas filter

Change the gas filter when it is dirty.

Combustion

If the combustion values measured before starting maintenance do not comply with applicable legislation or do not indicate efficient combustion, consult the Tab. Q or contact our Technical Support Service to implement the necessary adjustments.

It is advisable to set the burner according to the type of gas used and following the indications in Tab. Q.

EN 676		Air excess			
		Max. output $\lambda \leq 1.2$		Min. output $\lambda \leq 1.3$	
GAS	CO ₂ theoretical at max. 0% O ₂	CO ₂ % Calibration		CO	NO _x
		$\lambda = 1.2$	$\lambda = 1.3$	mg/kWh	mg/kWh
G 20	11.7	9.7	9.0	≤ 100	≤ 170
G 25	11.5	9.5	8.8	≤ 100	≤ 170
G 30	14.0	11.6	10.7	≤ 100	≤ 230
G 31	13.7	11.4	10.5	≤ 100	≤ 230

Tab. Q

6.2.4 Safety components

The safety components should be replaced at the end of their life cycle indicated in the following table.



The specified life cycles do not refer to the warranty terms indicated in the delivery or payment conditions.

Safety component	Life cycle
Flame control	10 years or 250,000 operation cycles
Flame sensor	10 years or 250,000 operation cycles
Gas valves (solenoid)	10 years or 250,000 operation cycles
Pressure switches	10 years or 250,000 operation cycles
Pressure adjuster	15 years
Servomotor (electronic cam) (if present)	10 years or 250,000 operation cycles
Oil valve (solenoid) (if present)	10 years or 250,000 operation cycles
Oil regulator (if present)	10 years or 250,000 operation cycles
Oil pipes/ couplings (metallic) (if present)	10 years
Fan impeller	10 years or 500,000 start-ups

Tab. R

6.3 Opening the burner



Disconnect the electrical supply from the burner by means of the main system switch.



Turn off the fuel interception tap.



Wait for the components in contact with heat sources to cool down completely.

To open the burner, use the same procedure set out in “Access to head internal part” on page 18.

6.4 Closing the burner

Refit following the steps described in “Access to head internal part” on page 18, but in reverse order; refit all burner components as they were originally assembled.



After carrying out maintenance, cleaning or checking operations, reassemble the cover and all the safety and protection devices of the burner.

7 Faults - Possible causes - Solutions



In the event the burner stops, in order to prevent any damage to the installation, do not unblock the burner more than twice in a row. If the burner locks out for a third time, contact the customer service.



In the event there are further lockouts or faults with the burner, the maintenance interventions must only be carried out by qualified, authorised personnel, in accordance with the contents of this manual and in compliance with the standards and regulations of current laws.

Signal	Problem	Possible cause	Recommended remedy
2 blinks ● ●	Once the pre-purging phase and safety time have passed, the burner goes into lockout without the appearance of the flame	The operation solenoid lets little gas through.	Increase
		One of the two solenoid valves does not open	Replace
		Gas pressure too low	Increase pressure at governor
		Ignition electrode incorrectly adjusted	Adjust it
		Electrode grounded due to broken insulation	Replace
		High voltage cable defective	Replace
		High voltage cable deformed by high temperature	Replace and protect
		Ignition transformer defective	Replace
		Incorrect valve or transformer electrical wiring	Check
		Defective flame control	Replace
		A closed valve upline the gas train	Open
		Air in pipework	Bleed air
		Gas valves unconnected or with interrupted coil	Check connections or replace coil
3 blinks ● ● ●	The burner does not switch on, and the lockout appears	Air pressure switch in operating position	Adjust or replace
	The burner switches on, but then stops in lockout	Air pressure switch does not switch owing to lack of air pressure:	
		Air pressure switch incorrectly adjusted	Adjust or replace
		Pressure switch pressure test point pipe blocked	Clean
		Poorly adjusted head	Adjust
		High pressure in the furnace	Connect air pressure switch to fan suction line
	Lockout during pre-purging phase	Defective motor control contactor (only three-phase version)	Replace
Defective electrical motor		Replace	
Motor lockout (defective electrical motor)		Replace	
4 blinks ● ● ● ●	The burner switches on, but then stops in lockout	Flame simulation	Replace the flame control
	Lockout when burner stops	Permanent flame in the combustion head or flame simulation	Eliminate persistence of flame or replace flame control
6 blinks ● ● ● ● ● ●	The burner switches on, but then stops in lockout	Defective or incorrectly adjusted servomotor	Adjust or replace
7 blinks ● ● ● ● ● ● ●	The burner goes into lockout immediately following the appearance of the flame	The operation solenoid lets little gas through	Increase
		Ionisation probe incorrectly adjusted	Adjust
		Insufficient ionisation (less than 5 A)	Check probe position
		Earth probe	Withdraw or replace cable
		Burner poorly earthed	Check earthing
		Phase and neutral connections inverted	Invert them
		Defective flame detection circuit	Replace the flame control
	Burner locks out when shifting from minimum to maximum output and vice versa	Too much air or too little gas	Adjust air and gas
	Burner goes into lockout during operation	Probe or ionisation cable grounded	Replace worn parts

Signal	Problem	Possible cause	Recommended remedy
10 blinks ●●●●●● ●●●●●●	The burner does not switch on, and the lock-out appears	Incorrect electrical wiring	Check
	The burner goes into lockout	Defective flame control	Replace
		Presence of electromagnetic disturbances in the thermostat lines	Filter or eliminate
		Presence of electromagnetic disturbance	Use the radio disturbance protection kit
No blink	The burner does not start	No electrical power supply	Check connections
		A limiter or safety control device is open	Adjust or replace
		Line fuse blocked	Replace
		Defective flame control	Replace
		No gas supply	Open the manual valves between contactor and train
		Mains gas pressure insufficient	Contact your gas company
		Minimum gas pressure switch fails to close	Adjust or replace
		Servomotor fails to move to min. ignition position	Replace
	The burner continues to repeat the start-up cycle, without lockout	The gas pressure in the gas mains lies very close to the value to which the gas pressure switch has been set. The sudden drop in pressure after valve opening causes temporary opening of the pressure switch itself, the valve immediately closes and the burner comes to a halt. Pressure increases again, the pressure switch closes again and the ignition cycle is repeated. And so on	Reduce the minimum gas pressure switch intervention pressure. Replace the gas filter cartridge.
	Ignition with pulsations	Poorly adjusted head	Adjust
		Ignition electrode incorrectly adjusted	Adjust it
		Incorrectly adjusted fan air damper: too much air	Adjust
		Output during ignition phase is too high	Reduce
	Burner does not reach maximum output	Remote control device TR fails to close	Adjust or replace
		Defective flame control	Replace
Defective servomotor		Replace	
Burner stops with air damper open	Defective servomotor	Replace	

Tab. S

A Appendix - Accessories**Analogue control signal converter kit**

Burner	Type	Code
All models	0/2 - 10V 0/4 - 20mA	20074479

Kit for modulating operation

Burner	Output regulator	Code
All models	RWF 50.2 3-POINT OUTLET	20073595
All models	RWF 55.5 COMPLETE WITH RS-485 INTERFACE	20074441
All models	RWF 55.6 COMPLETE WITH RS-485/PROFIBUS INTERFACE	20074442

Burner	Probe	Adjustment field	Code
All models	PT 100 temperature	- 100...+ 500°C	3010110
All models	4 - 20 mA pressure	0...2.5 bar	3010213
All models	4 - 20 mA pressure	0...16 bar	3010214

Potentiometer kit

Burner	Code
All models	20074487

Continuous purging kit

Burner	Code
All models	20074542

Flame sensor kit

Burner	Code
All models	20074548

Software interface kit

Burner	Code
All models	3002719

Soundproofing box kit

Burner	Type	dB(A)	Code
All models	C7	10	3010376

Spacer kit

Burner	Code
All models	20008903

Gas trains in compliance with EN 676

Please refer to manual.

B Appendix - Electrical panel layout

1	Contents
2	Indication of references
3	Single line output diagram (RS 310/M MZ 230 V - Direct Start Up) Single line output diagram (RS 310/M MZ 400 V - Direct Start Up) Single line output diagram (RS 410/M MZ 230 V - Direct Start Up) Single line output diagram (RS 410/M MZ 400 V - Direct Start Up) Single line output diagram (RS 310/M MZ 400 V - Star/Triangle Start Up) Single line output diagram (RS 410/M MZ 400 V - Star/Triangle Start Up) Single line output diagram (RS 510/M MZ 400 V - Star/Triangle Start Up) Single line output diagram (RS 610/M MZ 400 V - Star/Triangle Start Up)
4	Functional layout (RS 310-410/M MZ 230/400 V - Direct Start Up) Functional layout (RS 310-410-510-610/M MZ 400 V - Star/Triangle Start Up)
5	Functional layout RMG/M...
6	Gas train functional layout
7	Functional layout RMG/M...
8	Functional layout RMG/M...
9	Output power regulator electrical wiring ... (Internal)
10	Electrical wirings that are the responsibility of the installer (RS 310-410/M 230V - Direct Start Up) Electrical wirings that are the responsibility of the installer (RS 310-410/M 400V - Direct Start Up) Electrical wirings that are the responsibility of the installer (RS 310-410-510-610/M 400V - Star/Triangle Start Up)
11	Electrical wiring that the installer is responsible for
12	Regulator inputs/outputs

2 Indication of references

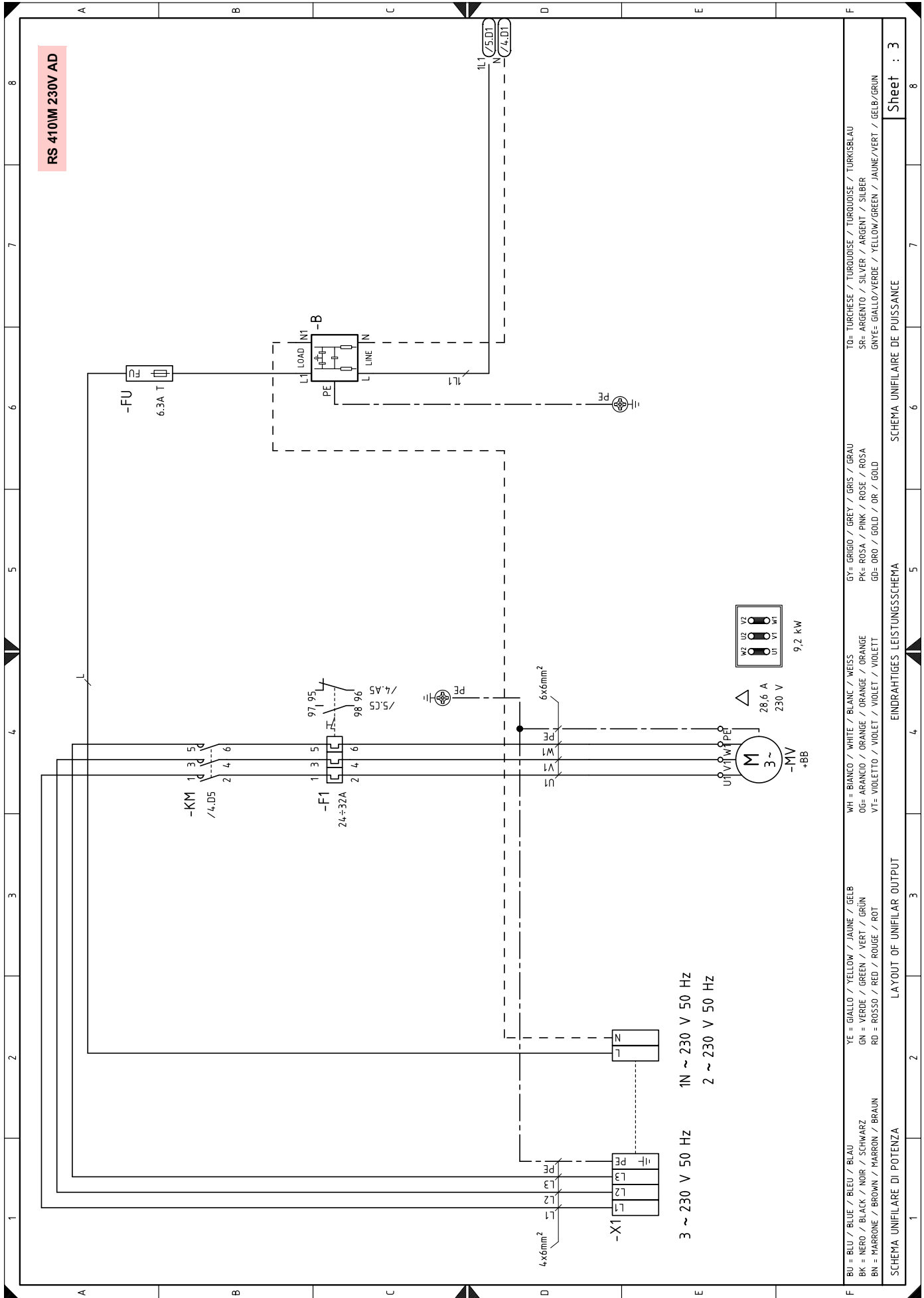

BU = BLU / BLUE / BLEU / BLAU
BK = NERO / BLACK / NOIR / SCHWARZ
BN = MARRONE / BROWN / MARRON / BRAUN
YE = GIALLO / YELLOW / JAUNE / GELB
GN = VERDE / GREEN / VERT / GRÜN
RD = ROSSO / RED / ROUGE / ROT
WH = BIANCO / WHITE / BLANC / WEISS
OG = ARANCIO / ORANGE / ORANGE / ORANGE
VI = VIOLETTA / VIOLET / VIOLET / VIOLETT
PK = ROSA / PINK / ROSE / ROSA
GD = ORO / GOLD / OR / GOLD
GY = GRIGIO / GREY / GRIS / GRAU
TO = TURCHESE / TURQUOISE / TURQUOISE / TURKISBLAU
SR = ARGENTO / SILVER / ARGENT / SILBER
GNVE = GIALLO/VERDE / YELLOW/GREEN / JAUNE/VERT / GELB/GRÜN

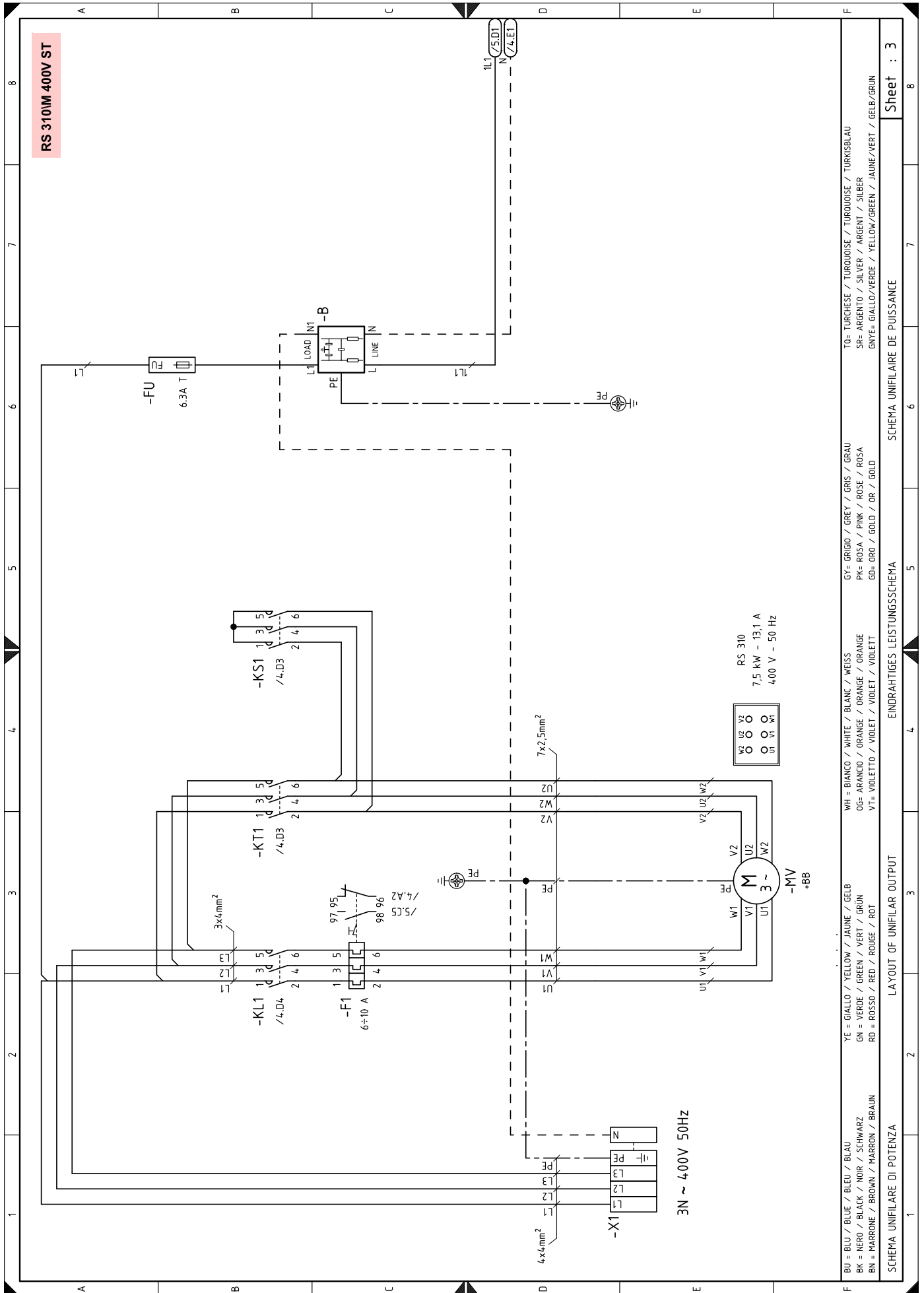

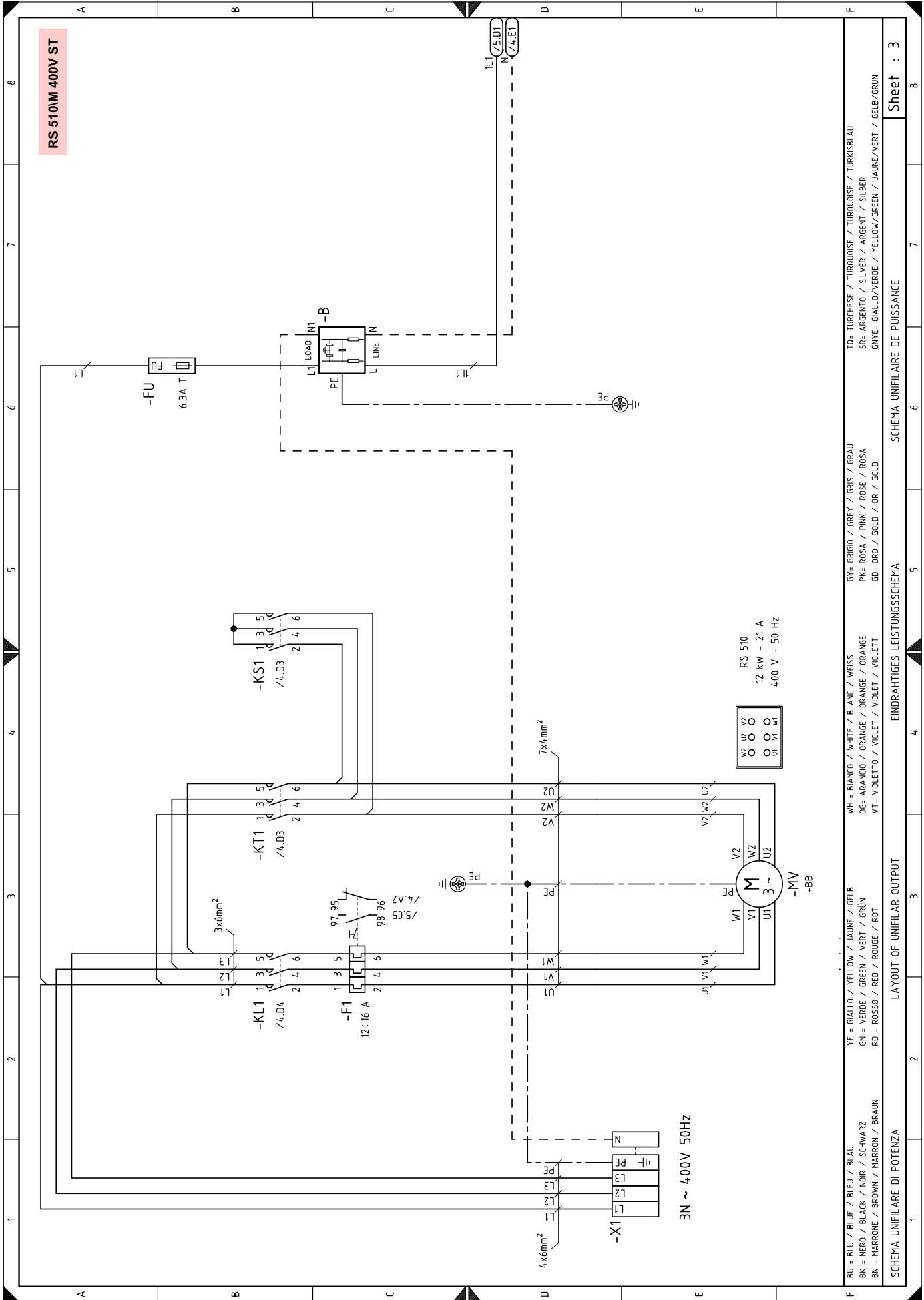

Sheet : 3

SCHEMA UNIFILARE DE PUISSANCE

EINDRAHTIGES LEISTUNGSSCHEMA

LAYOUT OF UNIFILAR OUTPUT

SCHEMA UNIFILARE DI POTENZA

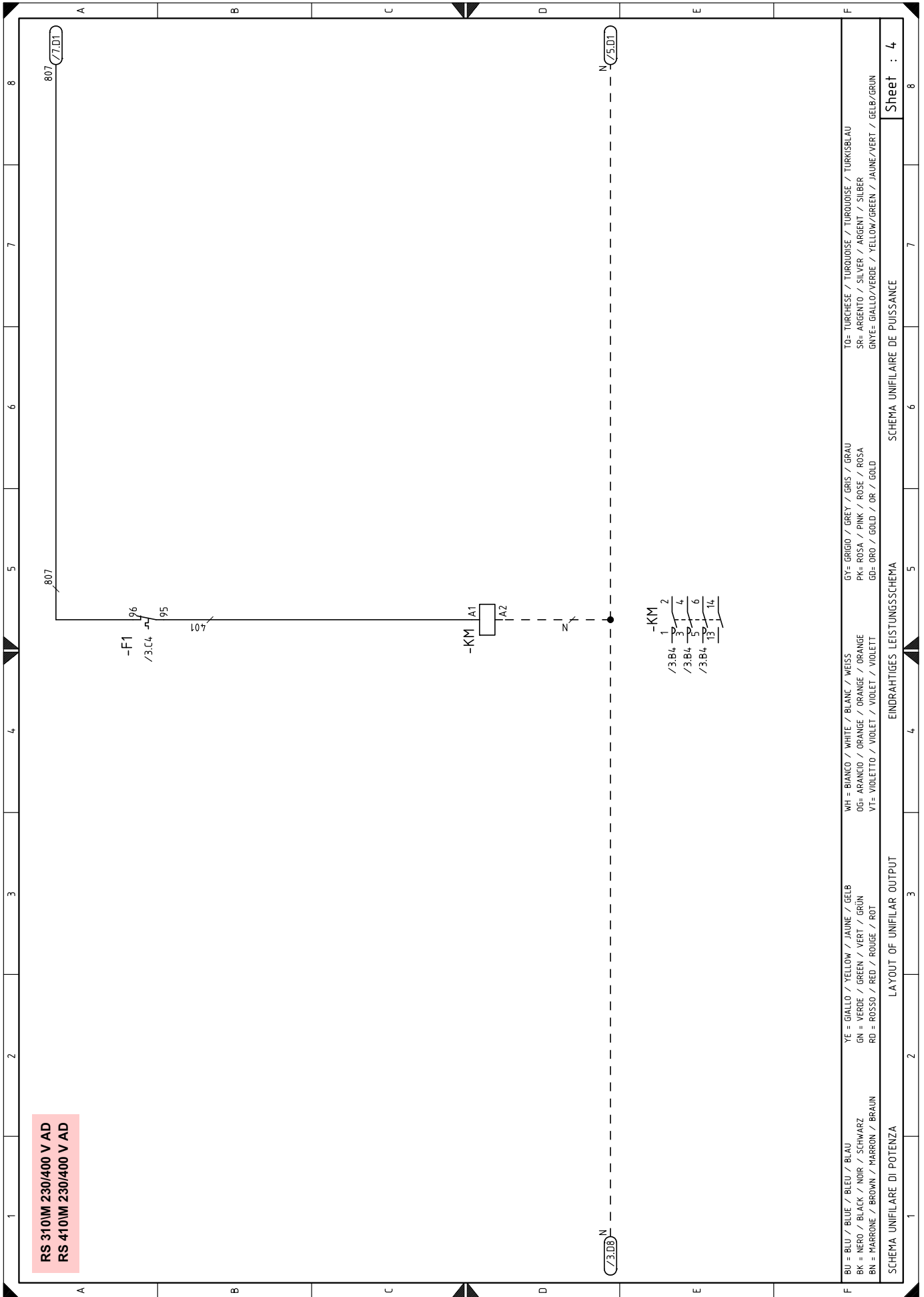

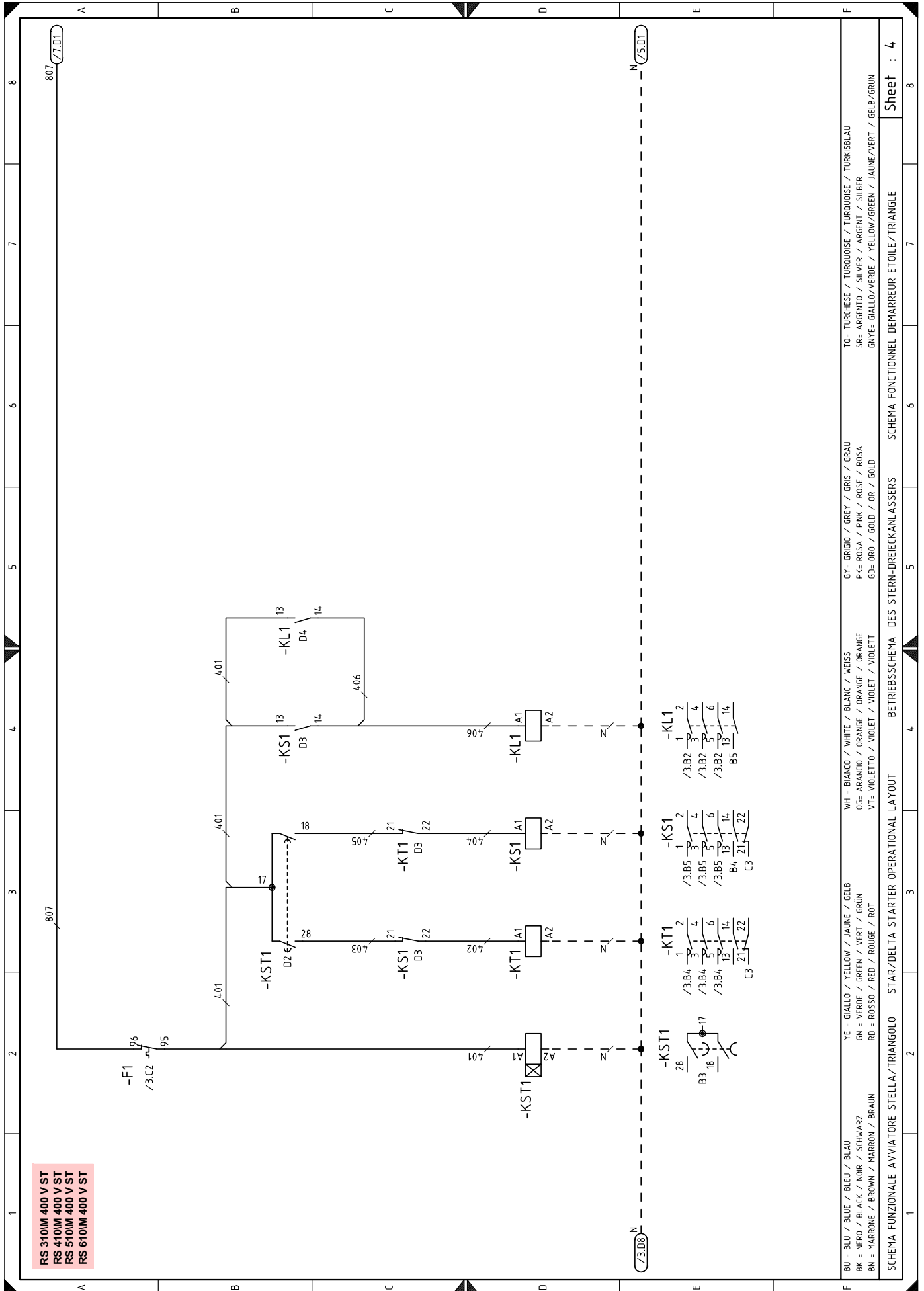

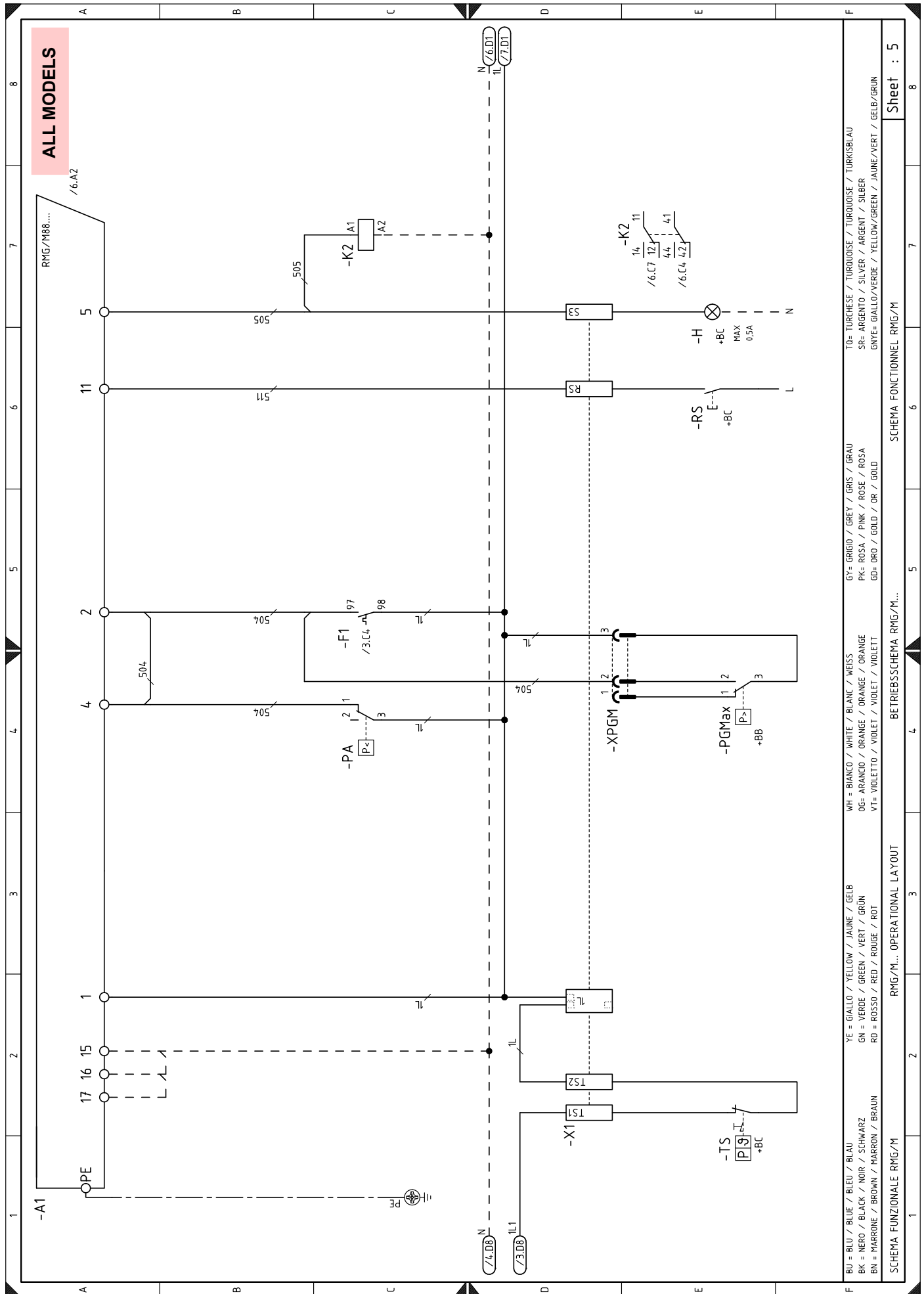

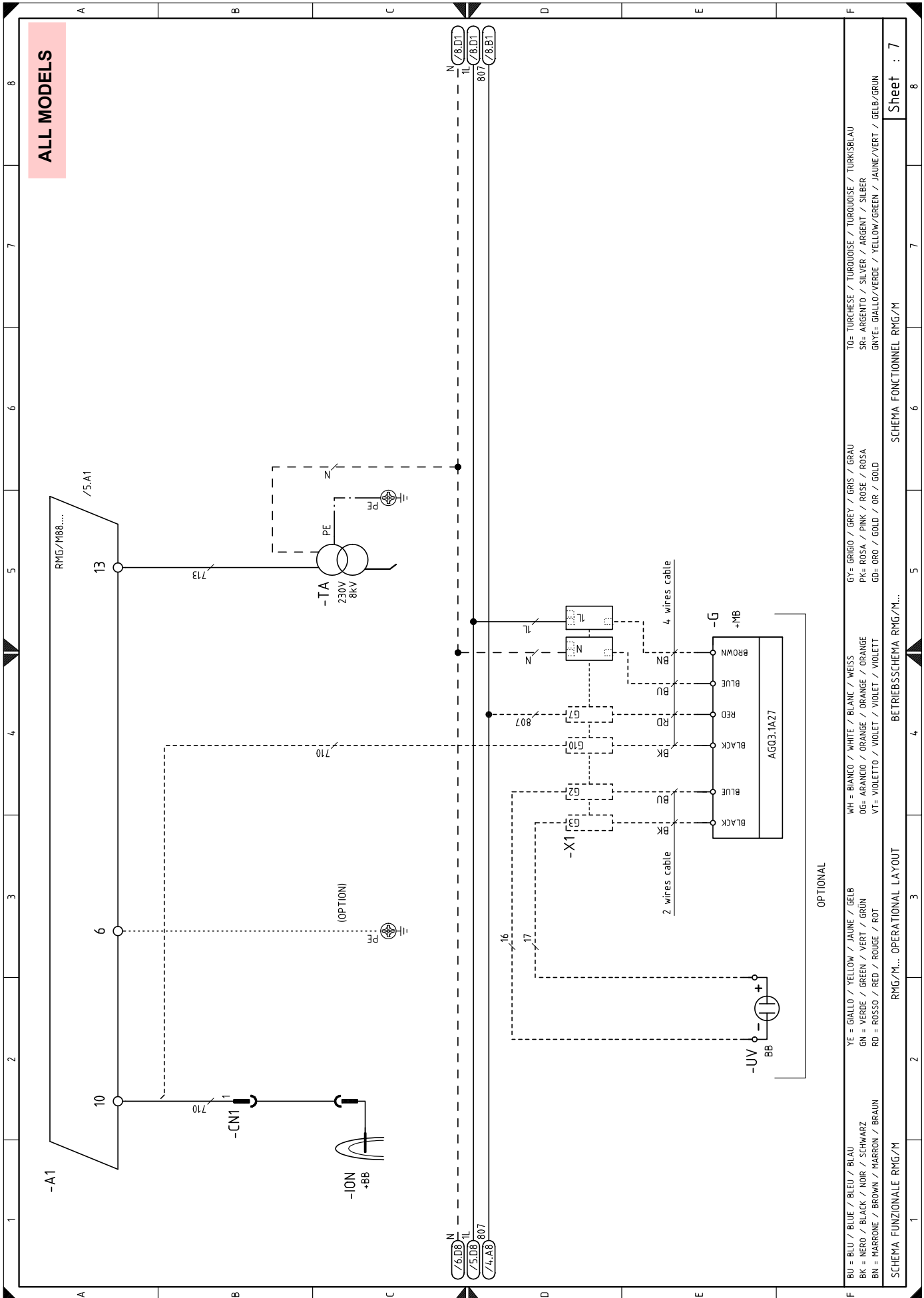

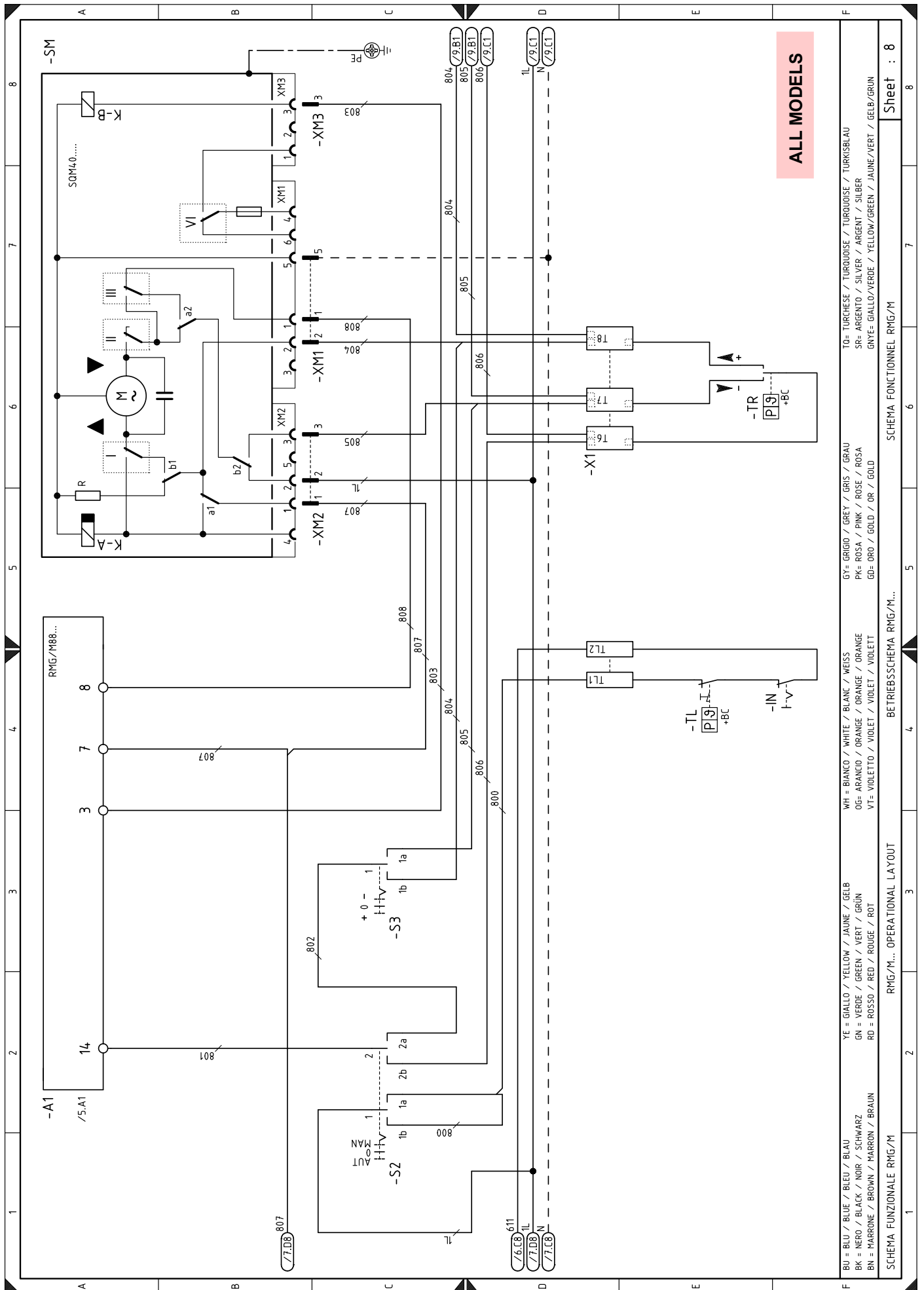

ALL MODELS

SCHEMA FONZIONALE RMG/M...
 BU = BLU / BLUE / BLEU / BLAU
 BK = NERO / BLACK / NOIR / SCHWARZ
 BN = MARRONE / BROWN / MARRON / BRAUN
 YE = GIALLO / YELLOW / JAUNE / GELB
 GN = VERDE / GREEN / VERT / GRÜN
 RD = ROSSO / RED / ROUGE / ROT
 WH = BIANCO / WHITE / BLANC / WEISS
 OG = ARANCIO / ORANGE / ORANGE / ORANGE
 VT = VIOLETTO / VIOLET / VIOLET / VIOLETT
 GY = GRIGIO / GREY / GRIS / GRAU
 PK = ROSA / PINK / ROSE / ROSA
 GB = ORO / GOLD / OR / EGOLD
 TO = TURCHESE / TURQUOISE / TURQUOISE / TURKISBLAU
 SR = ARGENTO / SILVER / ARGENT / SILBER
 GNYE = GIALLO/VERDE / YELLOW/GREEN / JAUNE/VERT / GELB/GRÜN

SCHEMA FONZIONALE RMG/M...
 RMG/M... OPERATIONAL LA YOUT
 SCHEMA FONCTIONNEL RMG/M...
 Sheet : 8

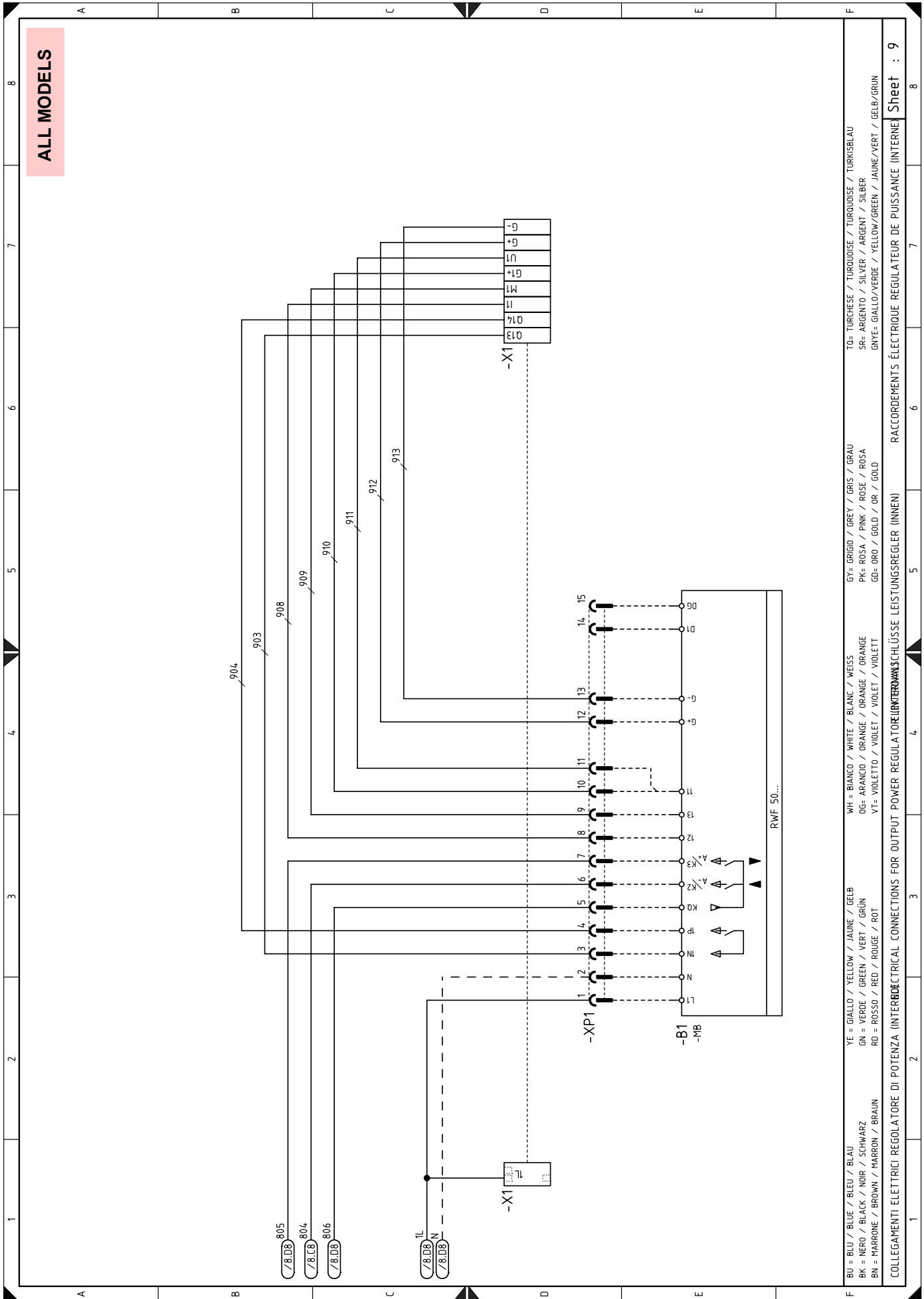

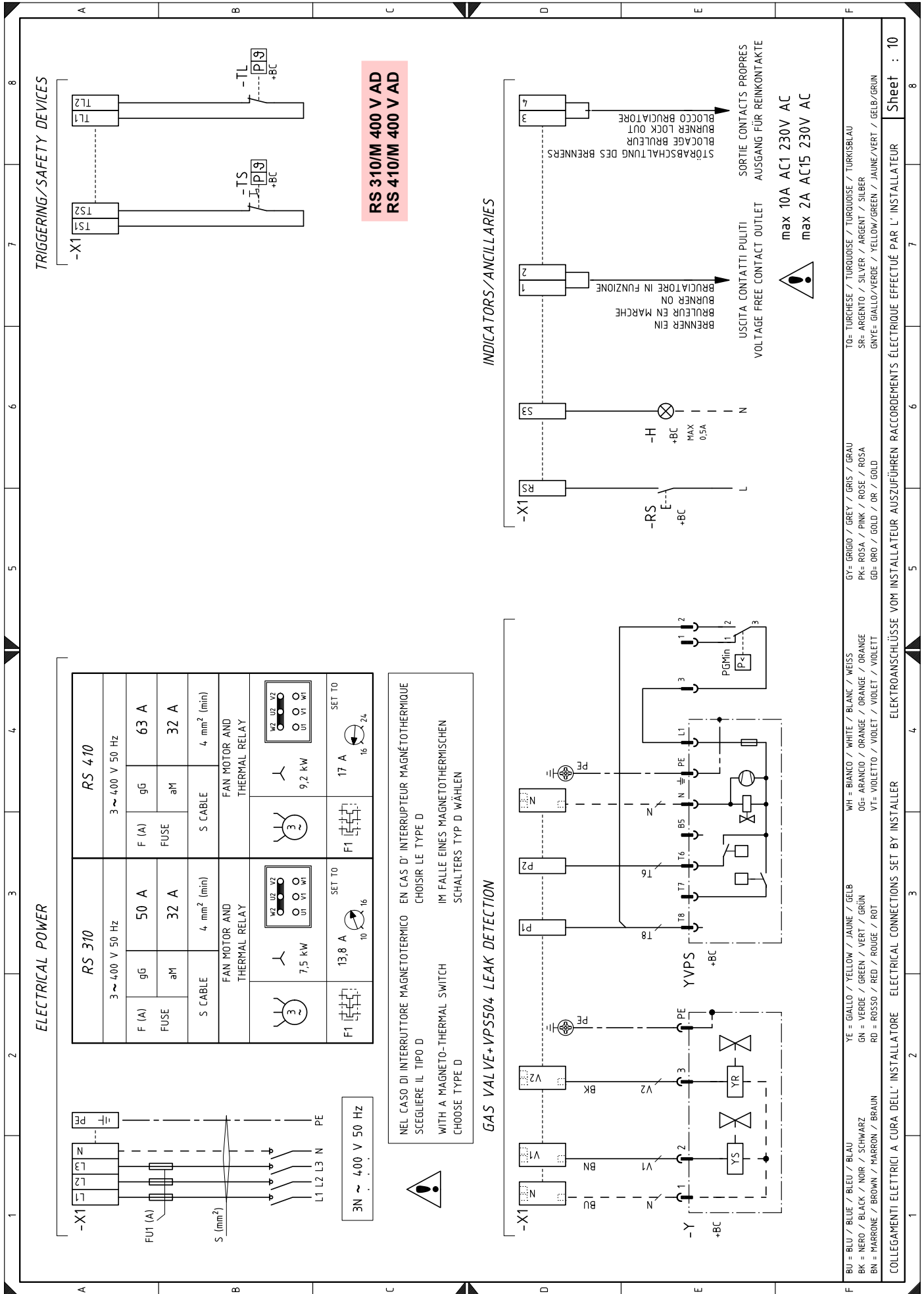

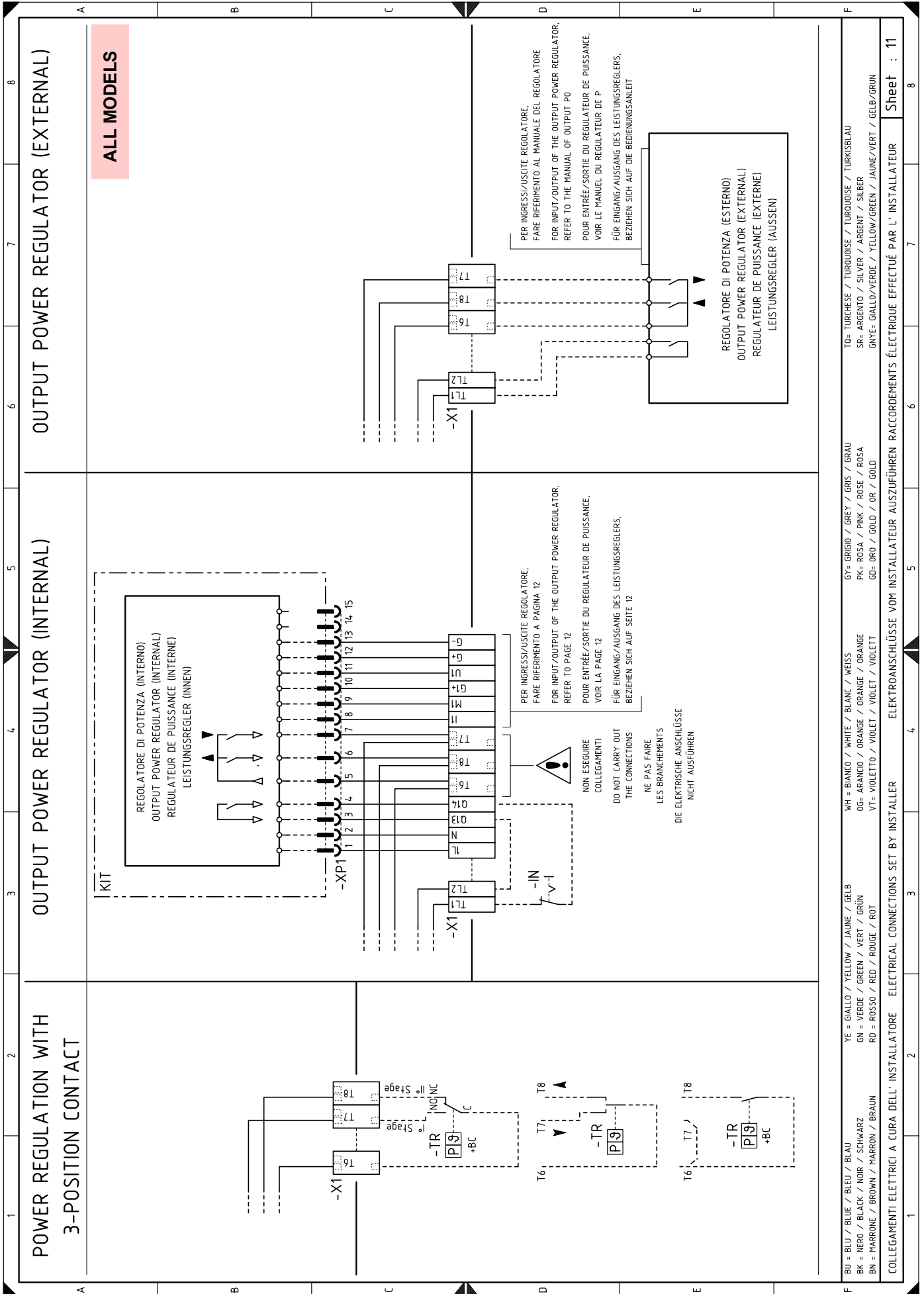

ALL MODELS

BU = BLU / BLUE / BLEU / BLAU	YE = GIALLO / YELLOW / JAUNE / GELB	WH = BIANCO / WHITE / BLANC / WEISS	GY = GRIGIO / GREY / GRIS / GRAU	T0= TURCHESE / TURKHOISE / TURKOISE / TURKUSBLAU
BK = NERO / BLACK / NOIR / SCHWARZ	GN = VERDE / GREEN / VERT / GRÜN	OG= ARANCIO / ORANGE / ORANGE / ORANGE	PK= ROSA / PINK / ROSE / ROSA	SR= ARGENTO / SILVER / ARGENT / SILBER
BN = MARRONE / BROWN / MARRON / BRAUN	RD = ROSSO / RED / ROUGE / ROT	V1= VIOLETTA / VIOLET / VIOLET / VIOLETT	GD= ORO / GOLD / OR / GOLD	GNTE= GIALLO/VERDE / YELLOW/GREEN / JAUNE/VERT / GELB/GRÜN

COLLEGAMENTI ELETTRICI A CURA DELL'INSTALLATORE ELECTRICAL CONNECTIONS SET BY INSTALLER ELEKTROANSCHLÜSSE VOM INSTALLATEUR AUSZUFÜHREN ACCORDÈMENTS ÉLECTRIQUE EFFECTUÉ PAR L'INSTALLATEUR

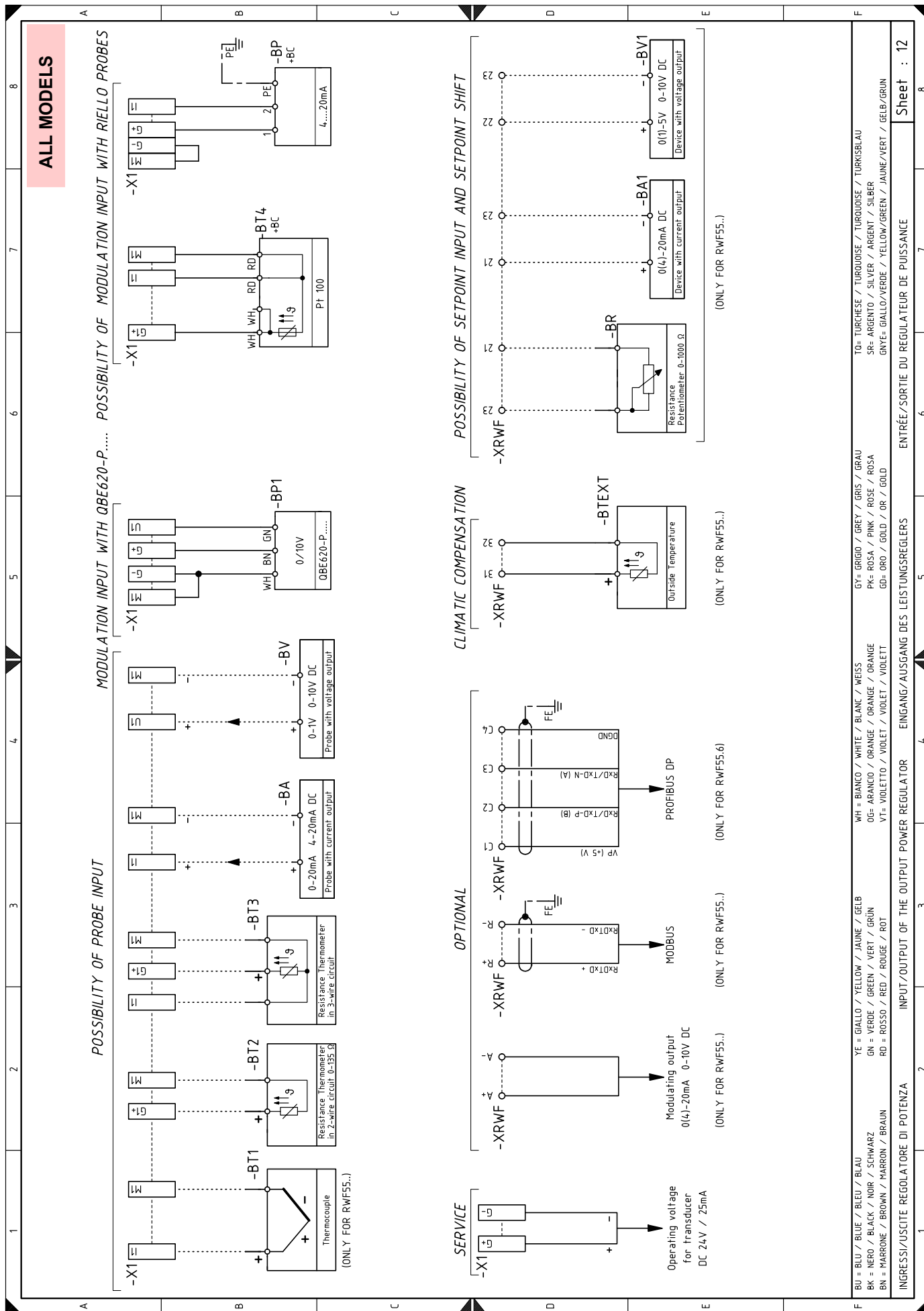

Wiring layout key

A1	Flame control
B	Suppressor
B1	Output power regulator internal
BA	Input in current DC 0...20 mA, 4...20 mA
BA1	Input in current DC 0...20 mA, 4...20 mA to modify remote setpoint
BP	Pressure probe
BP1	Pressure probe
BR	Remote setpoint potentiometer
BT1	Thermocouple probe
BT2	Probe Pt100, 2 wires
BT3	Probe Pt100, 3 wires
BT4	Probe Pt100, 3 wires
BTEXT	External probe for climatic compensation of the setpoint
BV	Input in voltage DC 0...1 V, 0...10 V
BV1	Input in voltage DC 0...1 V, 0...10 V to modify remote setpoint
F1	Fan motor thermal relay
FU	Auxiliary circuits safety fuse
G	Signal converter for UV sensor
H	Burner working lighting signal output
IN	Burner manual stop electric switch
ION	Ionisation probe
KL1	Star/triangle starter line contactor
KM	Direct start up contactor
KT1	Star/triangle starter triangle contactor
KS1	Start/triangle starter star contactor
KSM	Relay
KST1	Star/triangle starter timer
K1	Clean contacts output relay burner operating
K2	Clean contacts output relay burner lockout
MV	Fan motor
PA	Air pressure switch
PE	Burner earth
PGMin	Minimum gas pressure switch
PGMax	Maximum gas pressure switch
RS	Remote reset switch
S2	Off / automatic / manual selector
S3	Power increase / power reduction selector
SM	Servomotor
TA	Ignition transformer
TL	Limit thermostat/pressure switch
TR	Adjustment thermostat/pressure switch
TS	Safety thermostat/pressure switch
Y	Gas adjustment valve + gas safety valve
YVPS	Valve leak detection device
X1	Main terminal supply board
XM1	Servomotor connector 1
XM2	Servomotor connector 2
XM3	Servomotor connector 3
XP1	Connector for RWF output power regulator kit ... or signal converter
XPGM	Maximum gas pressure switch connector
XRWF	Terminal board for output power regulator RWF ...
UV	UV sensor (Optional only with kit)



If there is a problem with the fuse **FU**, there is a spare one in the fuse holder.

RIELLO

RIELLO S.p.A.
I-37045 Legnago (VR)
Tel.: +39.0442.630111
[http:// www.riello.it](http://www.riello.it)
[http:// www.riello.com](http://www.riello.com)