

# Condexa PRO SYSTEM

EN INSTALLATION, TECHNICAL ASSISTANCE SERVICE AND SYSTEM MANAGEMENT MANUAL

**RIELLO**

# CONTENTS

<b>1 GENERAL INFORMATION</b> .....	<b>3</b>	<b>4 SYSTEM MANAGEMENT</b> .....	<b>67</b>
1.1 General Safety Information .....	3	4.1 Setting the type of module addressing .....	67
1.2 Description of the appliance .....	3	4.2 Module addressing via dip switches .....	67
1.3 System layout .....	4	4.3 Address configuration via Display .....	68
1.3.1 In line lay-out (FRONT) with 2 modules .....	4	4.4 Bus connections .....	68
1.3.2 In line lay-out (FRONT) with 3 modules .....	5	4.5 Connection to External Zone controller .....	69
1.3.3 In line lay-out (FRONT) with 4 modules .....	6	4.6 Removing external zone .....	69
1.3.4 In line lay-out (FRONT) with 5 modules .....	7	4.7 Configuration of Dependent zones .....	70
1.3.5 In line lay-out (FRONT) with 6 modules .....	8	4.7.1 Deleting dependent zone .....	70
1.3.6 In line lay-out (FRONT) with 7 modules .....	9	<b>5 COMMISSIONING AND MAINTENANCE</b> .....	<b>71</b>
1.3.7 In line lay-out (FRONT) with 8 modules .....	10	5.1 Repositioning the front panels .....	71
1.3.8 In line lay-out (FRONT) with 9 modules .....	11	5.2 Putting the system into service .....	71
1.3.9 In line lay-out (FRONT) with 10 modules .....	12	<b>6 ELECTRONIC CONTROL</b> .....	<b>72</b>
1.3.10 B2B (BACK TO BACK) layout with 2 modules .....	13	6.2.1 Menu structure .....	73
1.3.11 B2B (BACK TO BACK) layout with 3 and 4 modules .....	14	6.1 Parameters specific to cascade systems .....	79
1.3.12 B2B (BACK TO BACK) layout with 5 and 6 modules .....	15	6.2 Setting the main parameters .....	83
1.3.13 B2B (BACK TO BACK) layout with 7 and 8 modules .....	16	6.2.1 Par.189 – module address (burner) .....	83
1.4 Installation premises .....	18	6.2.2 Par.147 – no. of modules (burners) .....	83
1.5 Air vent .....	19	6.2.3 Par.73 – Boiler address (cabinet) .....	83
<b>2 INSTALLATION</b> .....	<b>20</b>	6.3 Par.167 – no. of boilers (cabinets) .....	83
2.1 Preliminary installation measures .....	20	6.3.1 Par.7 – heating setpoint hysteresis .....	83
2.2 Assembly of the FRAMES .....	21	6.3.2 Par.97 – definition of the system with circulator / system with two-way valve .....	83
2.3 Positioning the CONDENSATE PIPES .....	29	6.4 Parameter 148: operating mode of the cascade .....	84
2.4 Positioning the 3" MANIFOLDS .....	30	6.4.1 Par 148 = 0 .....	84
2.5 Positioning the 5" MANIFOLDS .....	34	6.4.2 Par 148 = 1 .....	84
2.6 Positioning the CONDENSATE OUTLET .....	38	6.4.3 Par 148 = 2 .....	85
2.7 Positioning the GAS PIPES .....	39	<b>APPENDIX</b> .....	<b>86</b>
2.8 Positioning the DELIVERY-RETURN PIPES .....	42	<b>I SETTING PARAMETERS OF THE ADDITIONAL ZONE</b> .....	<b>86</b>
2.9 Positioning the SAFETY SECTION AND SEPARATOR .....	46	I.I Setting zone parameters (accessible only with installer password) .....	86
2.10 Neutralization of the condensate .....	53	I.I.I Menu structure .....	87
<b>3 CONFIGURATION OF THE MAIN BLOCK DIAGRAMS</b> .....	<b>54</b>	I.I.II Setting zone's climatic curve parameters (accessible only with installer password) .....	89
3.1 Configuration of the primary system .....	54	I.III Programming the zone .....	89
3.2 Configuration of the secondary system .....	55	I.IV Scheduling the time bands .....	90
3.3 Block diagram 1: Cascade of modules with primary sensor (SS) .....	57	I.V Information on the operation of the zone .....	90
3.3.1 Electrical power connections .....	58		
3.3.2 Sensor connections .....	58		
3.3.3 System parameters .....	59		
3.4 Block diagram 2: Cascade of modules with primary sensor (SS) and secondary (SC) .....	60		
3.4.1 Electrical power connections .....	61		
3.4.2 Sensor connections .....	61		
3.4.3 System parameters .....	62		
3.5 Block diagram 3: Cascade of cascades .....	63		
3.5.1 Sensor and data bus connections .....	64		
3.5.2 System parameters .....	65		

The following symbols are used in this manual:

 **CAUTION!** = Identifies actions that require caution and adequate preparation.

 **STOP!** = Identifies actions that you MUST NOT do.  
= identifies a sequence where "N" corresponds to the number of the phase described.

This manual, Code 20225049 – Rev. 2 (03/2026) comprises 92 pages.

## 1 GENERAL INFORMATION

### 1.1 General Safety Information

**⚠** This instruction booklet is an integral part of the instruction manual of the single appliance **Condexa PRO**, to which you are referred for the GENERAL WARNINGS and for the BASIC SAFETY RULES

**⚠** The instructions provided for the cascade accessories are an integral part of this manual. They must be referred to and must not be disposed of.

### 1.2 Description of the appliance

**Condexa PRO** can be combined in cascade with other generators in order to create modular thermal power units, consisting of modules connected hydraulically, the electronic controls of which communicate via bus. Each module is designed to be combined with other identical units. **Condexa PRO** provides accessories for configurations of up to a maximum of 10 units, except for the 135 model, whose maximum number of modules in cascade is 8.

For each model it is possible to configure the different types of installations either in line (i.e. Front) or back to back (i.e. Back to Back).

Model	Condexa PRO					
	57 P	70 P	90	100	115	135
No. modules	Total Cascade Power (kW)					
1	57	68	90	97	112	131
2	114	136	180	194	224	262
3	171	204	270	291	336	393
4	228	272	360	388	448	524
5	285	340	450	485	560	655
6	342	408	540	582	672	786
7	399	476	630	679	784	917
8	456	544	720	776	896	1048
9	513	612	810	873	1008	ND
10	570	680	900	970	1120	ND

### 1.3 System layout

#### 1.3.1 In line lay-out (FRONT) with 2 modules

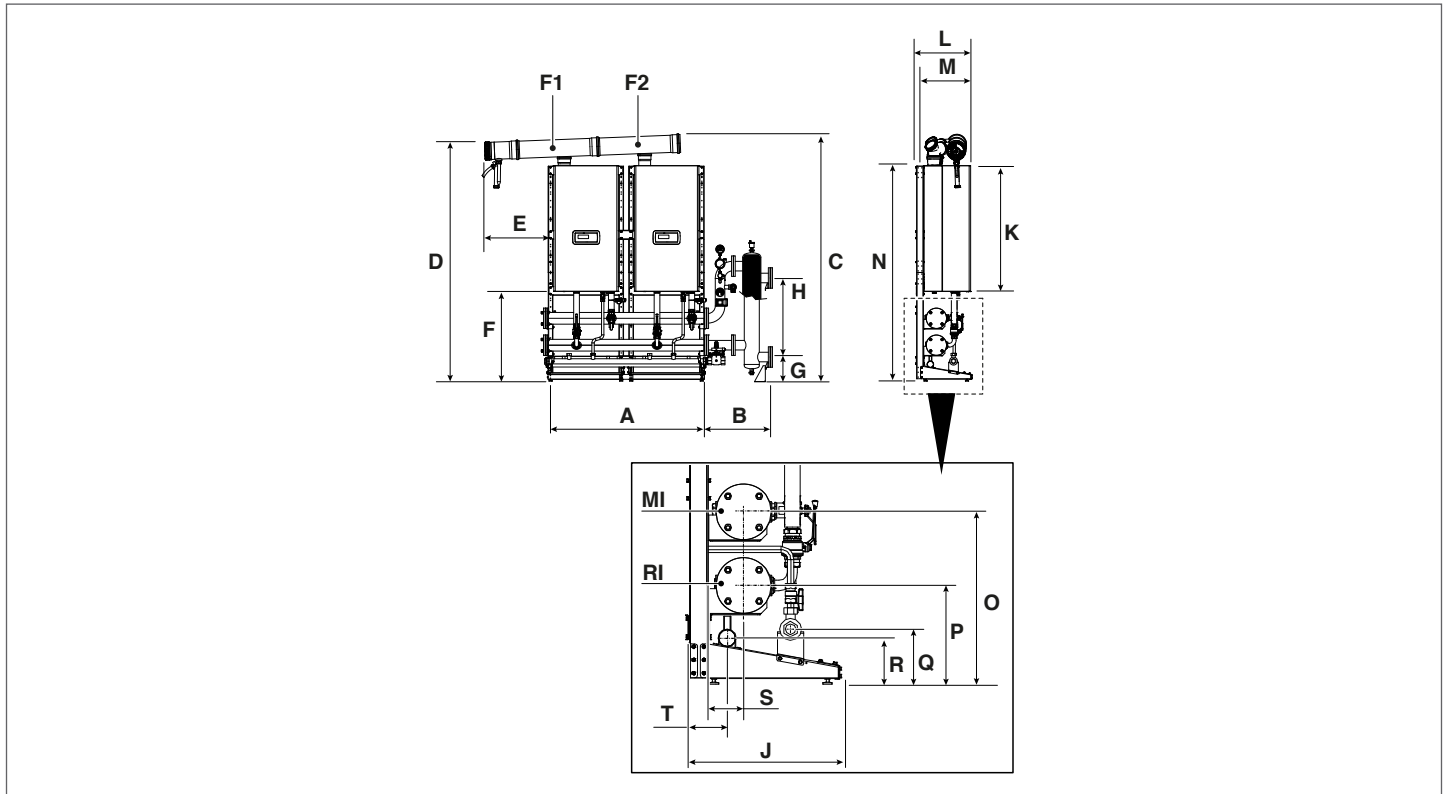

DESCRIPTION	Condexa PRO							
	57 P	70 P	90	100	115	135		
A	1494	1494	1494	1494	1494	1494	mm	
B	591	591	591	591	591	591	mm	
C	2131	2131	2131	2131	2301	2301	mm	
D	2051	2051	2051	2051	2221	2221	mm	
E	594	594	594	594	594	594	mm	
F	834	834	834	834	834	834	mm	
G	230	230	230	230	230	230	mm	
H	735	735	735	735	735	735	mm	
J	525	525	525	525	525	525	mm	
K	1010	1010	1010	1010	1173	1173	mm	
L	511	511	511	511	511	511	mm	
M	436	436	436	436	436	436	mm	
N	1999	1999	1999	1999	1999	1999	mm	
O	584	584	584	584	584	584	mm	
P	334	334	334	334	334	334	mm	
Q	186	186	186	186	186	186	mm	
R	156	156	156	156	156	156	mm	
S	121	121	121	121	121	121	mm	
T	137	137	137	137	137	137	mm	
F1	Ø 160	Ø 160	Ø 160	Ø 160	Ø 160	Ø 160	mm	
F2	Ø 160	Ø 160	Ø 160	Ø 160	Ø 160	Ø 160	mm	
RI							Ø 3"	inch
MI							Ø 3"	inch

1.3.2 In line lay-out (FRONT) with 3 modules

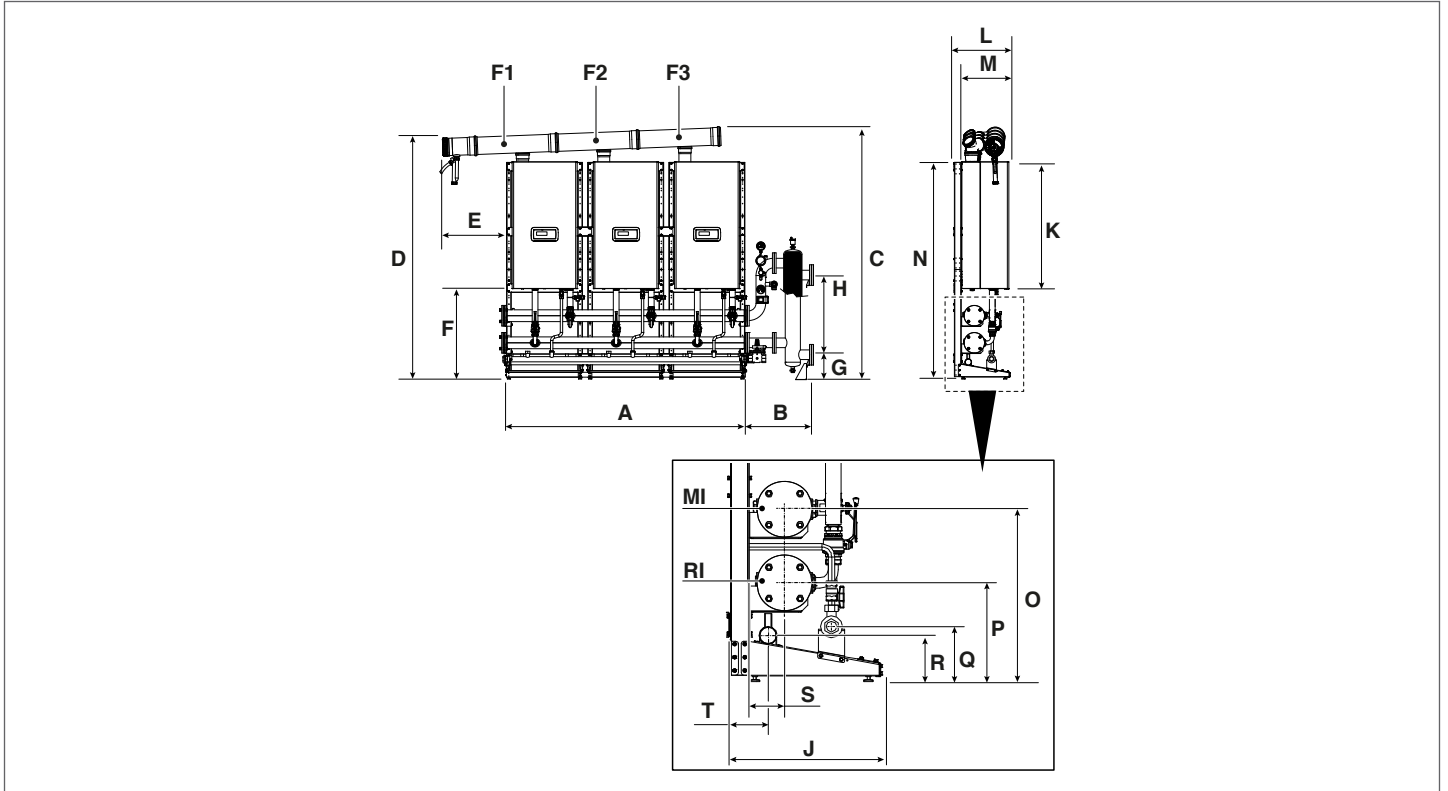

DESCRIPTION	Condexa PRO						
	57 P	70 P	90	100	115	135	
A	2242	2242	2242	2242	2242	2242	mm
B	591	591	591	591	591	591	mm
C	2161	2161	2161	2161	2240	2240	mm
D	2051	2051	2051	2051	2221	2221	mm
E	594	594	594	594	594	594	mm
F	834	834	834	834	834	834	mm
G	230	230	230	230	230	230	mm
H	735	735	735	735	735	735	mm
J	525	525	525	525	525	525	mm
K	1010	1010	1010	1010	1173	1173	mm
L	511	511	511	511	511	511	mm
M	436	436	436	436	436	436	mm
N	1999	1999	1999	1999	1999	1999	mm
O	584	584	584	584	584	584	mm
P	334	334	334	334	334	334	mm
Q	186	186	186	186	186	186	mm
R	156	156	156	156	156	156	mm
S	121	121	121	121	121	121	mm
T	137	137	137	137	137	137	mm
F1	∅ 160	∅ 160	∅ 160	∅ 160	∅ 160	∅ 160	mm
F2	∅ 160	∅ 160	∅ 160	∅ 160	∅ 160	∅ 160	mm
F3	∅ 160	∅ 160	∅ 160	∅ 160	∅ 160	∅ 160	mm
RI				∅ 3"			inch
MI				∅ 3"			inch

1.3.3 In line lay-out (FRONT) with 4 modules

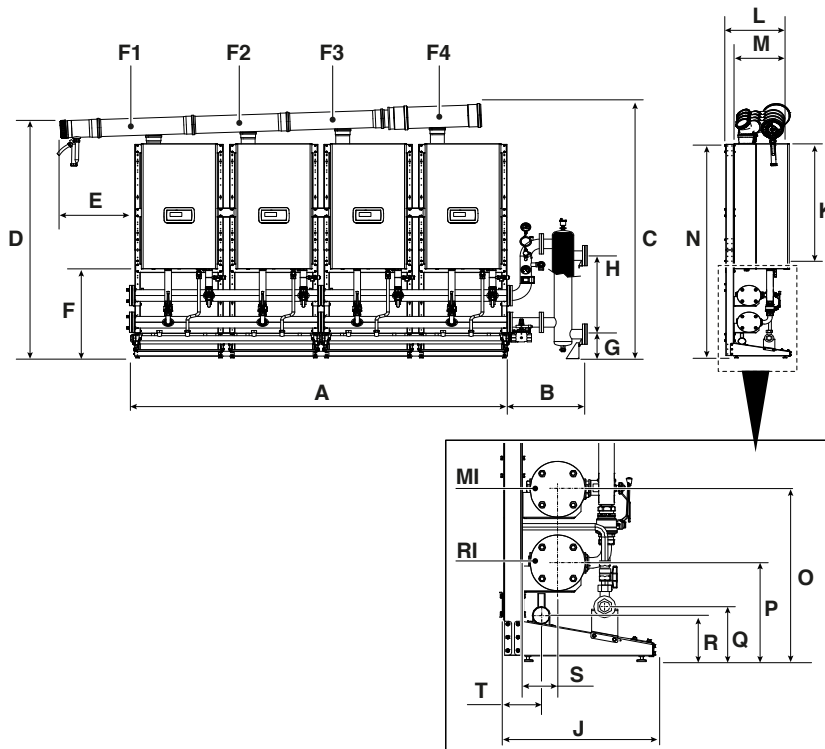

DESCRIPTION	Condexa PRO							
	57 P	70 P	90	100	115	135		
A	2988	2988	2988	2988	2988	2988	mm	
B	3"	591	591	591	591	591	mm	
	5"	1159	1159	1159	1159	1159	mm	
C	2190	2190	2190	2190	2382	2382	mm	
D	2051	2051	2051	2051	2221	2221	mm	
E	594	594	594	594	594	594	mm	
F	834	834	834	834	834	834	mm	
G	3"	230	230	230	230	N.A.	mm	
	5"	N.A.	N.A.	N.A.	N.A.	N.A.	337	
H	3"	735	735	735	735	N.A.	mm	
	5"	N.A.	N.A.	N.A.	N.A.	N.A.	850	
J	525	525	525	525	525	525	mm	
K	1010	1010	1010	1010	1173	1173	mm	
L	511	511	511	511	511	511	mm	
M	436	436	436	436	436	436	mm	
N	1999	1999	1999	1999	1999	1999	mm	
O	584	584	584	584	584	584	mm	
P	334	334	334	334	334	334	mm	
Q	186	186	186	186	186	186	mm	
R	156	156	156	156	156	156	mm	
S	121	121	121	121	121	121	mm	
T	137	137	137	137	137	137	mm	
F1	∅ 160	∅ 160	∅ 160	∅ 160	∅ 160	∅ 160	mm	
F2	∅ 160	∅ 160	∅ 160	∅ 160	∅ 160	∅ 160	mm	
F3	∅ 160	∅ 160	∅ 160	∅ 160	∅ 160	∅ 160	mm	
F4	∅ 160	∅ 160	∅ 160	∅ 160	∅ 160	∅ 200	mm	
RI			∅ 3"			∅ 5"	inch	
MI			∅ 3"			∅ 5"	inch	

1.3.4 In line lay-out (FRONT) with 5 modules

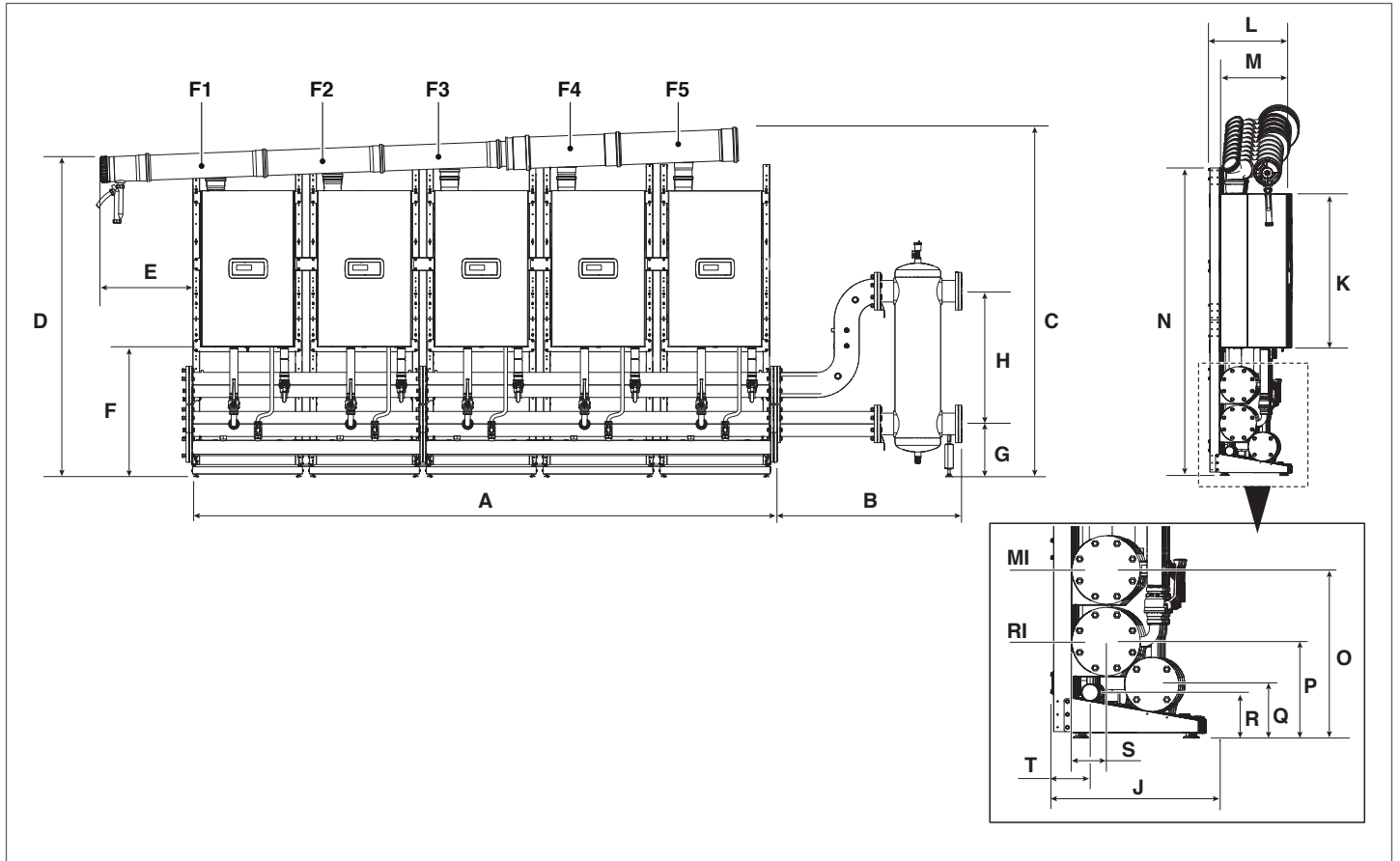

DESCRIPTION	Condexa PRO						
	57 P	70 P	90	100	115	135	
A	3736	3736	3736	3736	3736	3736	mm
B	3"	591	591	591	591	591	mm
	5"	1159	1159	1159	1159	1159	mm
C	2241	2241	2241	2241	2411	2411	mm
D	2051	2051	2051	2051	2221	2221	mm
E	594	594	594	594	594	594	mm
F	834	834	834	834	834	834	mm
G	3"	230	230	230	N.A.	N.A.	mm
	5"	N.A.	N.A.	N.A.	337	337	mm
H	3"	735	735	735	N.A.	N.A.	mm
	5"	N.A.	N.A.	N.A.	850	850	mm
J	525	525	525	525	525	525	mm
K	1010	1010	1010	1010	1173	1173	mm
L	511	511	511	511	511	511	mm
M	436	436	436	436	436	436	mm
N	1999	1999	1999	1999	1999	1999	mm
O	584	584	584	584	584	584	mm
P	334	334	334	334	334	334	mm
Q	186	186	186	186	186	186	mm
R	156	156	156	156	156	156	mm
S	121	121	121	121	121	121	mm
T	137	137	137	137	137	137	mm
F1	Ø 160	Ø 160	Ø 160	Ø 160	Ø 160	Ø 160	mm
F2	Ø 160	Ø 160	Ø 160	Ø 160	Ø 160	Ø 160	mm
F3	Ø 160	Ø 160	Ø 160	Ø 160	Ø 160	Ø 160	mm
F4	Ø 160	Ø 160	Ø 160	Ø 160	Ø 160	Ø 200	mm
F5	Ø 160	Ø 160	Ø 200	Ø 200	Ø 200	Ø 200	mm
RI			Ø 3"			Ø 5"	inch
MI			Ø 3"			Ø 5"	inch

1.3.5 In line lay-out (FRONT) with 6 modules

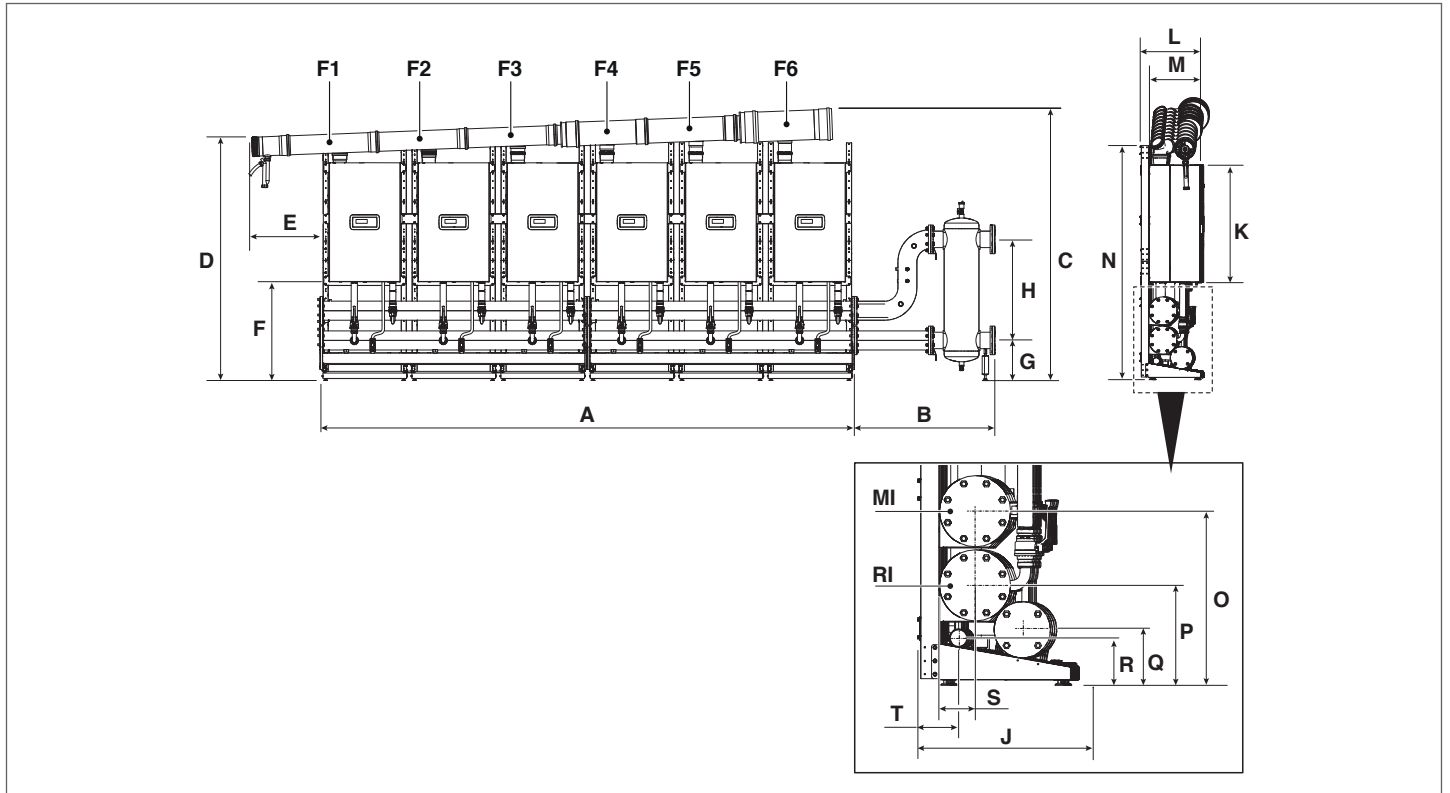

DESCRIPTION	Condexa PRO							
	57 P	70 P	90	100	115	135		
A	4484	4484	4484	4484	4484	4484	mm	
B	3"	591	591	591	591	591	mm	
	5"	1159	1159	1159	1159	1159	mm	
C	2270	2270	2270	2270	2461	2461	mm	
D	2051	2051	2051	2051	2221	2221	mm	
E	594	594	594	594	594	594	mm	
F	834	834	834	834	834	834	mm	
G	3"	230	230	N.A.	N.A.	N.A.	mm	
	5"	N.A.	N.A.	337	337	337	mm	
H	3"	735	735	N.A.	N.A.	N.A.	mm	
	5"	N.A.	N.A.	850	850	850	mm	
J	525	525	525	525	525	525	mm	
K	1010	1010	1010	1010	1173	1173	mm	
L	511	511	511	511	511	511	mm	
M	436	436	436	436	436	436	mm	
N	1999	1999	1999	1999	1999	1999	mm	
O	584	584	584	584	584	584	mm	
P	334	334	334	334	334	334	mm	
Q	186	186	186	186	186	186	mm	
R	156	156	156	156	156	156	mm	
S	121	121	121	121	121	121	mm	
T	137	137	137	137	137	137	mm	
F1	Ø 160	Ø 160	Ø 160	Ø 160	Ø 160	Ø 160	mm	
F2	Ø 160	Ø 160	Ø 160	Ø 160	Ø 160	Ø 160	mm	
F3	Ø 160	Ø 160	Ø 160	Ø 160	Ø 160	Ø 160	mm	
F4	Ø 160	Ø 160	Ø 160	Ø 160	Ø 160	Ø 200	mm	
F5	Ø 160	Ø 160	Ø 200	Ø 200	Ø 200	Ø 200	mm	
F6	Ø 160	Ø 160	Ø 200	Ø 200	Ø 200	Ø 250	mm	
RI		Ø 3"			Ø 5"		inch	
MI		Ø 3"			Ø 5"		inch	

1.3.6 In line lay-out (FRONT) with 7 modules

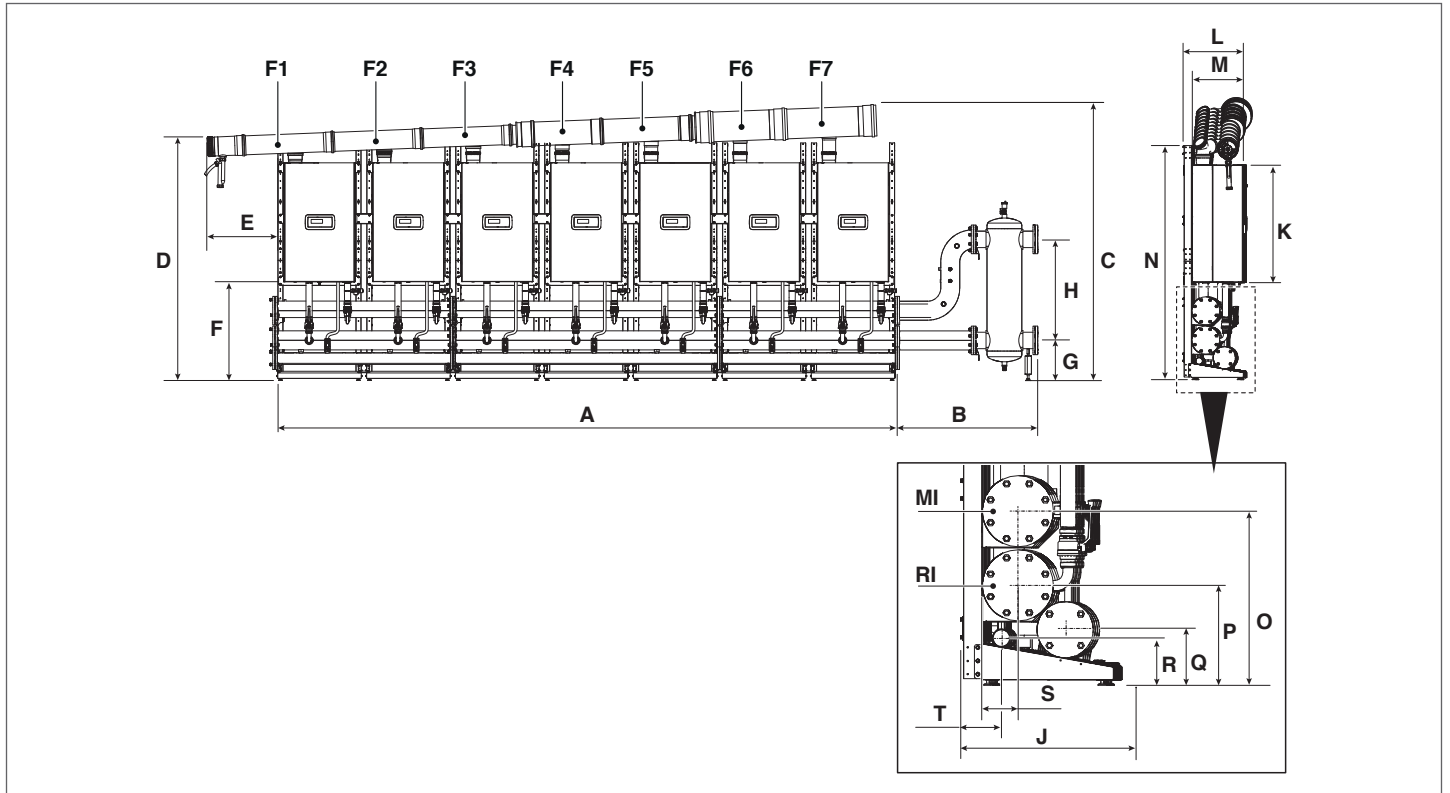

DESCRIPTION	Condexa PRO						
	57 P	70 P	90	100	115	135	
A	5230	5230	5230	5230	5230	5230	mm
B	3"	591	591	591	591	591	mm
	5"	1159	1159	1159	1159	1159	mm
C	2295	2295	2295	2295	2490	2490	mm
D	2051	2051	2051	2051	2221	2221	mm
E	594	594	594	594	594	594	mm
F	834	834	834	834	834	834	mm
G	3"	230	230	N.A.	N.A.	N.A.	mm
	5"	N.A.	N.A.	337	337	337	mm
H	3"	735	735	N.A.	N.A.	N.A.	mm
	5"	N.A.	N.A.	850	850	850	mm
J	525	525	525	525	525	525	mm
K	1010	1010	1010	1010	1173	1173	mm
L	511	511	511	511	511	511	mm
M	436	436	436	436	436	436	mm
N	1999	1999	1999	1999	1999	1999	mm
O	584	584	584	584	584	584	mm
P	334	334	334	334	334	334	mm
Q	186	186	186	186	186	186	mm
R	156	156	156	156	156	156	mm
S	121	121	121	121	121	121	mm
T	137	137	137	137	137	137	mm
F1	∅ 160	∅ 160	∅ 160	∅ 160	∅ 160	∅ 160	mm
F2	∅ 160	∅ 160	∅ 160	∅ 160	∅ 160	∅ 160	mm
F3	∅ 160	∅ 160	∅ 160	∅ 160	∅ 160	∅ 160	mm
F4	∅ 160	∅ 160	∅ 160	∅ 160	∅ 160	∅ 200	mm
F5	∅ 160	∅ 160	∅ 200	∅ 200	∅ 200	∅ 200	mm
F6	∅ 160	∅ 160	∅ 200	∅ 200	∅ 200	∅ 250	mm
F7	∅ 160	∅ 200	∅ 200	∅ 200	∅ 250	∅ 250	mm
RI		∅ 3"			∅ 5"		inch
MI		∅ 3"			∅ 5"		inch

1.3.7 In line lay-out (FRONT) with 8 modules

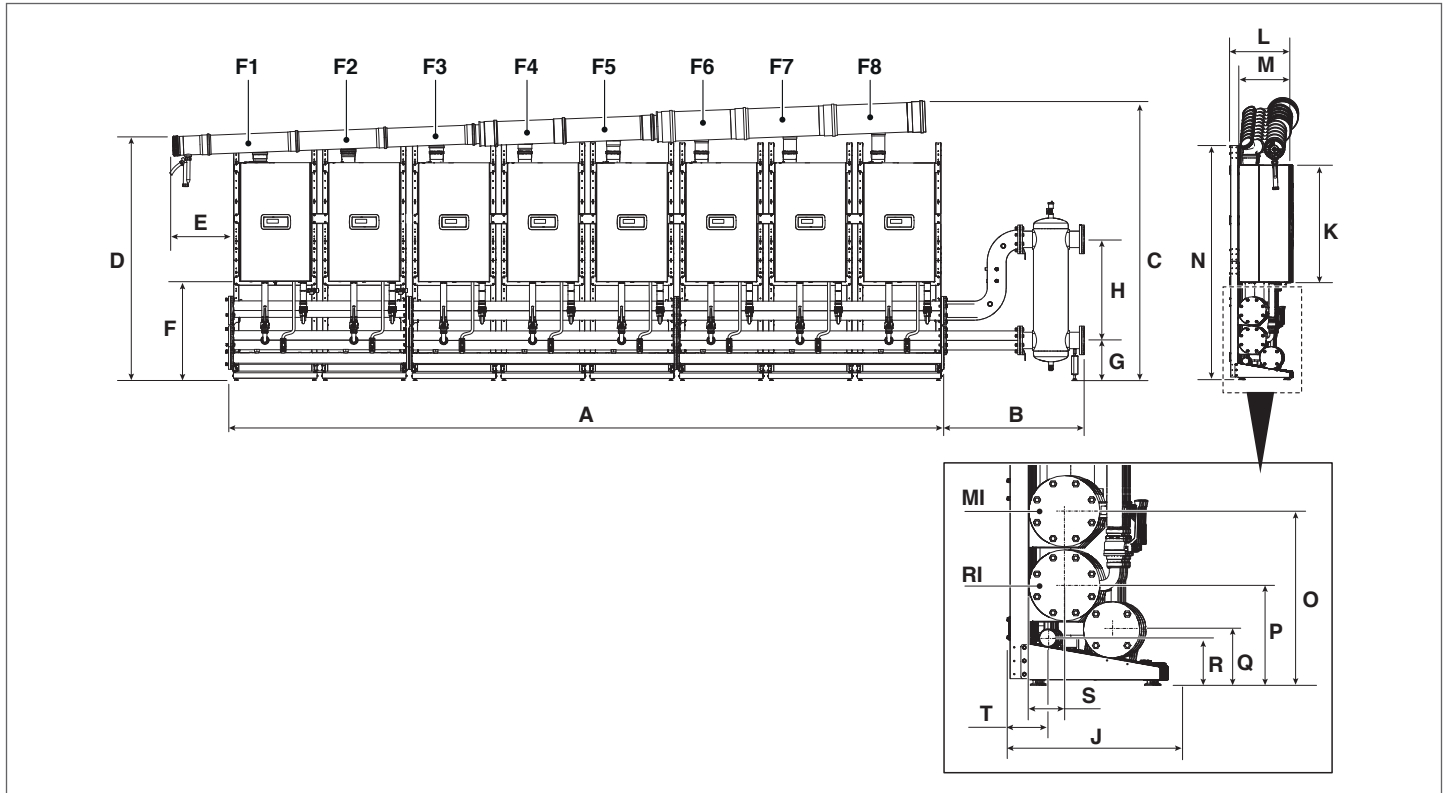

DESCRIPTION	Condexa PRO						
	57 P	70 P	90	100	115	135	
A	5978	5978	5978	5978	5978	5978	mm
B	1159	1159	1159	1159	1159	1159	mm
C	2346	2346	2346	2346	2519	2519	mm
D	2051	2051	2051	2051	2221	2221	mm
E	594	594	594	594	594	594	mm
F	834	834	834	834	834	834	mm
G	3"	230	N.A.	N.A.	N.A.	N.A.	mm
	5"	N.A.	337	337	337	337	mm
H	3"	735	N.A.	N.A.	N.A.	N.A.	mm
	5"	N.A.	850	850	850	850	mm
J	525	525	525	525	525	525	mm
K	1010	1010	1010	1010	1173	1173	mm
L	511	511	511	511	511	511	mm
M	436	436	436	436	436	436	mm
N	1999	1999	1999	1999	1999	1999	mm
O	584	584	584	584	584	584	mm
P	334	334	334	334	334	334	mm
Q	186	186	186	186	186	186	mm
R	156	156	156	156	156	156	mm
S	121	121	121	121	121	121	mm
T	137	137	137	137	137	137	mm
F1	∅ 160	∅ 160	∅ 160	∅ 160	∅ 160	∅ 160	mm
F2	∅ 160	∅ 160	∅ 160	∅ 160	∅ 160	∅ 160	mm
F3	∅ 160	∅ 160	∅ 160	∅ 160	∅ 160	∅ 160	mm
F4	∅ 160	∅ 160	∅ 160	∅ 160	∅ 160	∅ 200	mm
F5	∅ 160	∅ 160	∅ 200	∅ 200	∅ 200	∅ 200	mm
F6	∅ 160	∅ 160	∅ 200	∅ 200	∅ 200	∅ 250	mm
F7	∅ 160	∅ 200	∅ 200	∅ 200	∅ 250	∅ 250	mm
F8	∅ 200	∅ 200	∅ 250	∅ 250	∅ 250	∅ 250	mm
RI	∅ 3"			∅ 5"			inch
MI	∅ 3"			∅ 5"			inch

1.3.8 In line lay-out (FRONT) with 9 modules

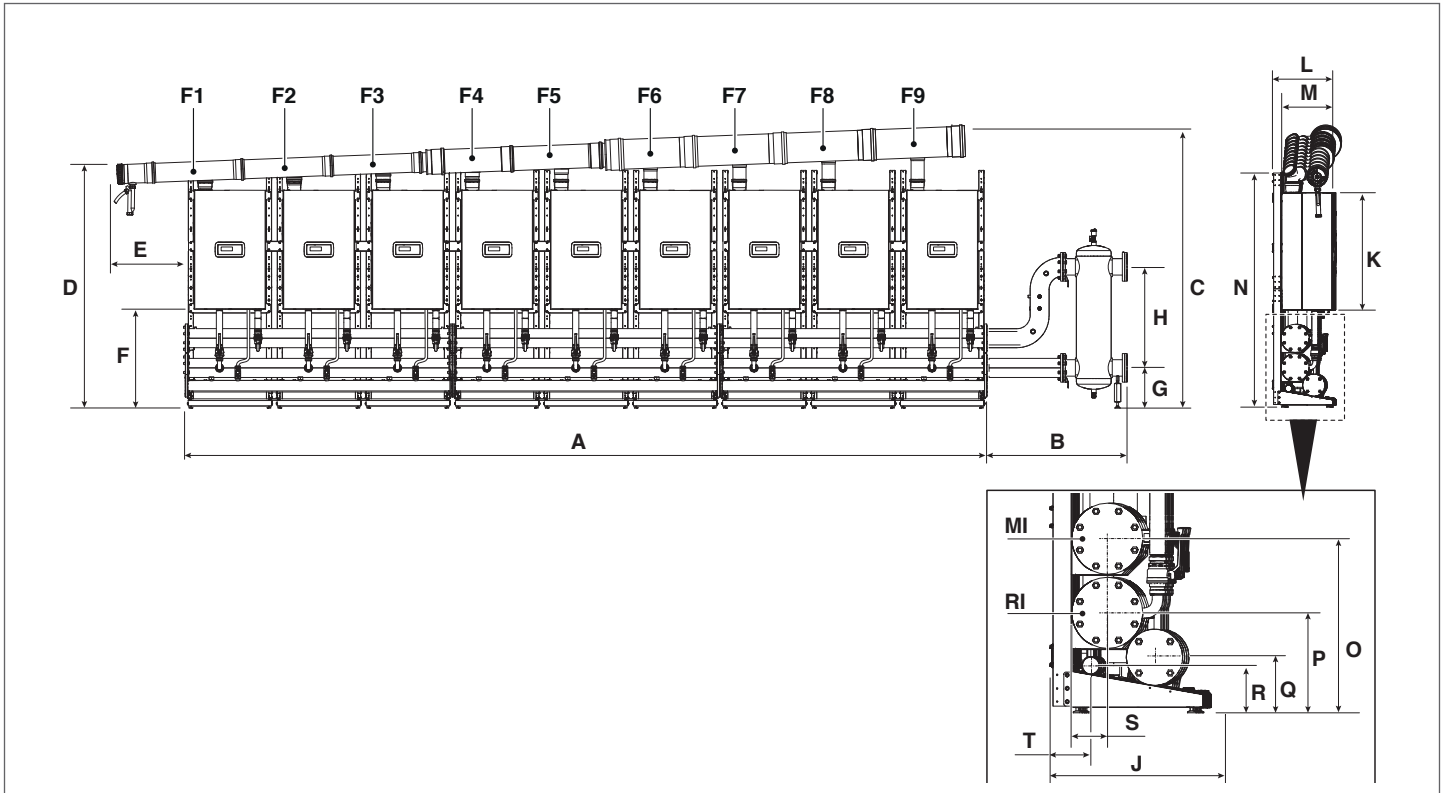

DESCRIPTION	Condexa PRO						
	57 P	70 P	90	100	115	135	
A	6726	6726	6726	6726	6726	N.A.	mm
B	1159	1159	1159	1159	1159	N.A.	mm
C	2376	2376	2376	2376	2548	N.A.	mm
D	2051	2051	2051	2051	2221	N.A.	mm
E	594	594	594	594	594	N.A.	mm
F	834	834	834	834	834	N.A.	mm
G	3"	N.A.	N.A.	N.A.	N.A.	N.A.	mm
	5"	337	337	337	337	N.A.	mm
H	3"	N.A.	N.A.	N.A.	N.A.	N.A.	mm
	5"	850	850	850	850	N.A.	mm
J	525	525	525	525	525	N.A.	mm
K	1010	1010	1010	1010	1173	N.A.	mm
L	511	511	511	511	511	N.A.	mm
M	436	436	436	436	436	N.A.	mm
N	1999	1999	1999	1999	1999	N.A.	mm
O	584	584	584	584	584	N.A.	mm
P	334	334	334	334	334	N.A.	mm
Q	186	186	186	186	186	N.A.	mm
R	156	156	156	156	156	N.A.	mm
S	121	121	121	121	121	N.A.	mm
T	137	137	137	137	137	N.A.	mm
F1	Ø 160	Ø 160	Ø 160	Ø 160	Ø 160	N.A.	mm
F2	Ø 160	Ø 160	Ø 160	Ø 160	Ø 160	N.A.	mm
F3	Ø 160	Ø 160	Ø 160	Ø 160	Ø 160	N.A.	mm
F4	Ø 160	Ø 160	Ø 160	Ø 160	Ø 160	N.A.	mm
F5	Ø 160	Ø 160	Ø 200	Ø 200	Ø 200	N.A.	mm
F6	Ø 160	Ø 160	Ø 200	Ø 200	Ø 200	N.A.	mm
F7	Ø 160	Ø 200	Ø 200	Ø 200	Ø 250	N.A.	mm
F8	Ø 200	Ø 200	Ø 250	Ø 250	Ø 250	N.A.	mm
F9	Ø 200	Ø 200	Ø 250	Ø 250	Ø 250	N.A.	mm
RI				Ø 5"			inch
MI				Ø 5"			inch

1.3.9 In line lay-out (FRONT) with 10 modules

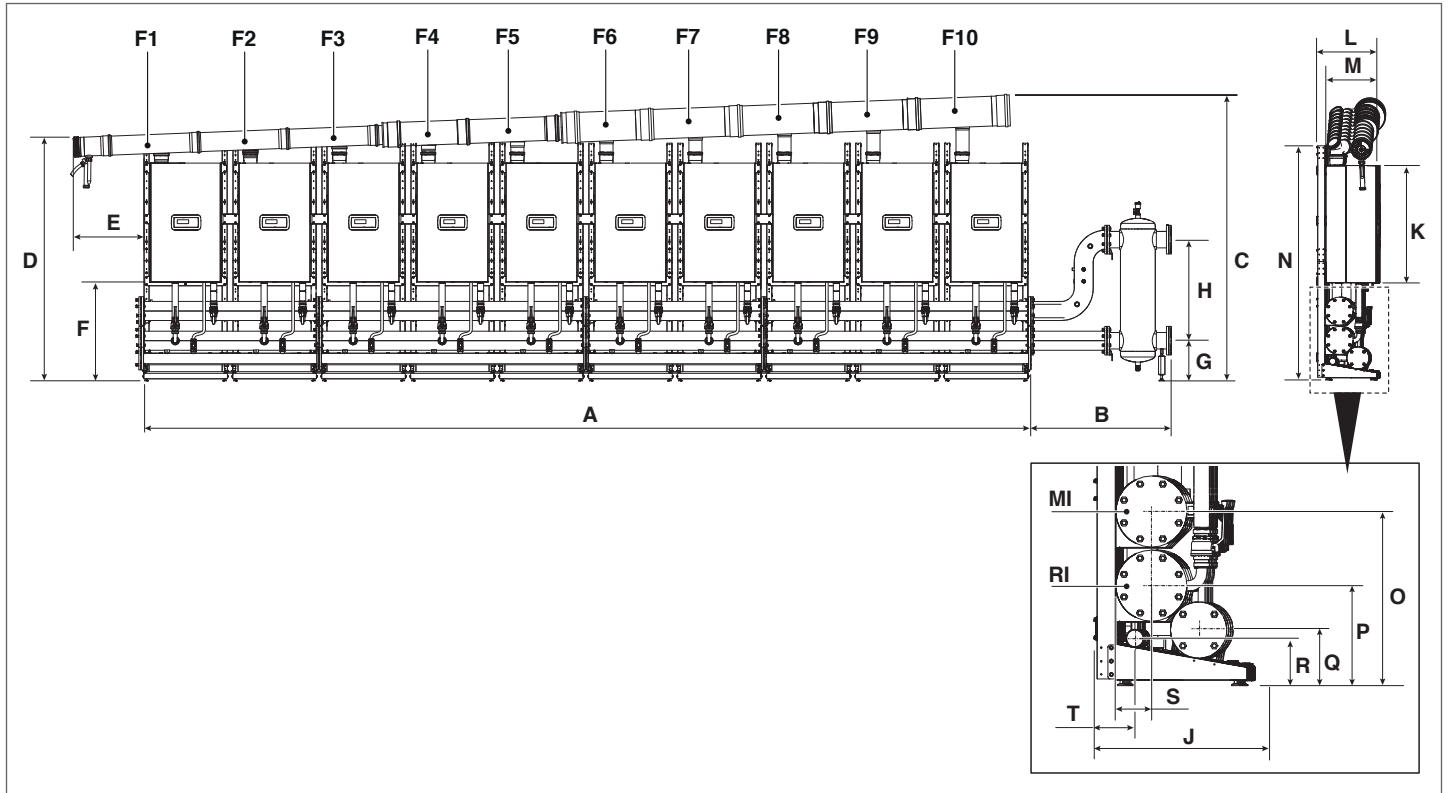

DESCRIPTION	Condexa PRO						
	57 P	70 P	90	100	115	135	
A	7472	7472	7472	7472	7472	N.A.	mm
B	1159	1159	1159	1159	1159	N.A.	mm
C	2405	2405	2405	2405	2578	N.A.	mm
D	2051	2051	2051	2051	2221	N.A.	mm
E	594	594	594	594	594	N.A.	mm
F	834	834	834	834	834	N.A.	mm
G	3"	N.A.	N.A.	N.A.	N.A.	N.A.	mm
	5"	337	337	337	337	N.A.	mm
H	3"	N.A.	N.A.	N.A.	N.A.	N.A.	mm
	5"	850	850	850	850	N.A.	mm
J	525	525	525	525	525	N.A.	mm
K	1010	1010	1010	1010	1173	N.A.	mm
L	511	511	511	511	511	N.A.	mm
M	436	436	436	436	436	N.A.	mm
N	1999	1999	1999	1999	1999	N.A.	mm
O	584	584	584	584	584	N.A.	mm
P	334	334	334	334	334	N.A.	mm
Q	186	186	186	186	186	N.A.	mm
R	156	156	156	156	156	N.A.	mm
S	121	121	121	121	121	N.A.	mm
T	137	137	137	137	137	N.A.	mm
F1	∅ 160	∅ 160	∅ 160	∅ 160	∅ 160	N.A.	mm
F2	∅ 160	∅ 160	∅ 160	∅ 160	∅ 160	N.A.	mm
F3	∅ 160	∅ 160	∅ 160	∅ 160	∅ 160	N.A.	mm
F4	∅ 160	∅ 160	∅ 160	∅ 160	∅ 160	N.A.	mm
F5	∅ 160	∅ 160	∅ 200	∅ 200	∅ 200	N.A.	mm
F6	∅ 160	∅ 160	∅ 200	∅ 200	∅ 200	N.A.	mm
F7	∅ 160	∅ 200	∅ 200	∅ 200	∅ 250	N.A.	mm
F8	∅ 200	∅ 200	∅ 250	∅ 250	∅ 250	N.A.	mm
F9	∅ 200	∅ 200	∅ 250	∅ 250	∅ 250	N.A.	mm
F10	∅ 200	∅ 200	∅ 250	∅ 250	∅ 250	N.A.	mm
RI				∅ 5"			inch
MI				∅ 5"			inch

1.3.10 B2B (BACK TO BACK) layout with 2 modules

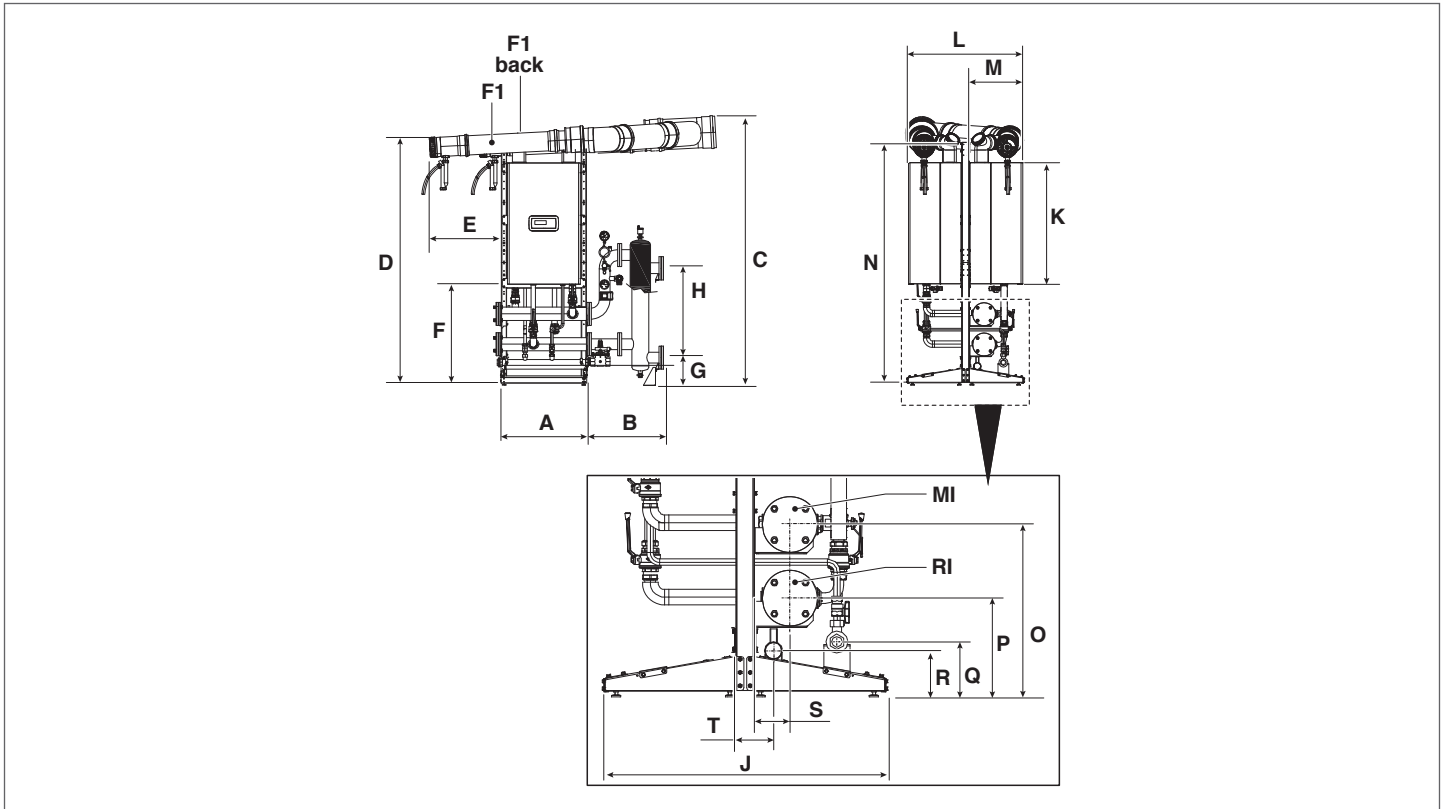

DESCRIPTION	Condexa PRO						
	57 P	70 P	90	100	115	135	
A	746	746	746	746	746	746	mm
B	591	591	591	591	591	591	mm
C	2220	2220	2220	2220	2390	2390	mm
D	2051	2051	2051	2051	2221	2221	mm
E	594	594	594	594	594	594	mm
F	834	834	834	834	834	834	mm
G	230	230	230	230	230	230	mm
H	735	735	735	735	735	735	mm
J	969	969	969	969	969	969	mm
K	1010	1010	1010	1010	1173	1173	mm
L	942	942	942	942	942	942	mm
M	436	436	436	436	436	436	mm
N	1999	1999	1999	1999	1999	1999	mm
O	584	584	584	584	584	584	mm
P	334	334	334	334	334	334	mm
Q	186	186	186	186	186	186	mm
R	156	156	156	156	156	156	mm
S	121	121	121	121	121	121	mm
T	137	137	137	137	137	137	mm
F1	∅ 160	∅ 160	∅ 160	∅ 160	∅ 160	∅ 160	mm
F1 back	∅ 160	∅ 160	∅ 160	∅ 160	∅ 160	∅ 160	mm
RI				∅ 3"			inch
MI				∅ 3"			inch

1.3.11 B2B (BACK TO BACK) layout with 3 and 4 modules

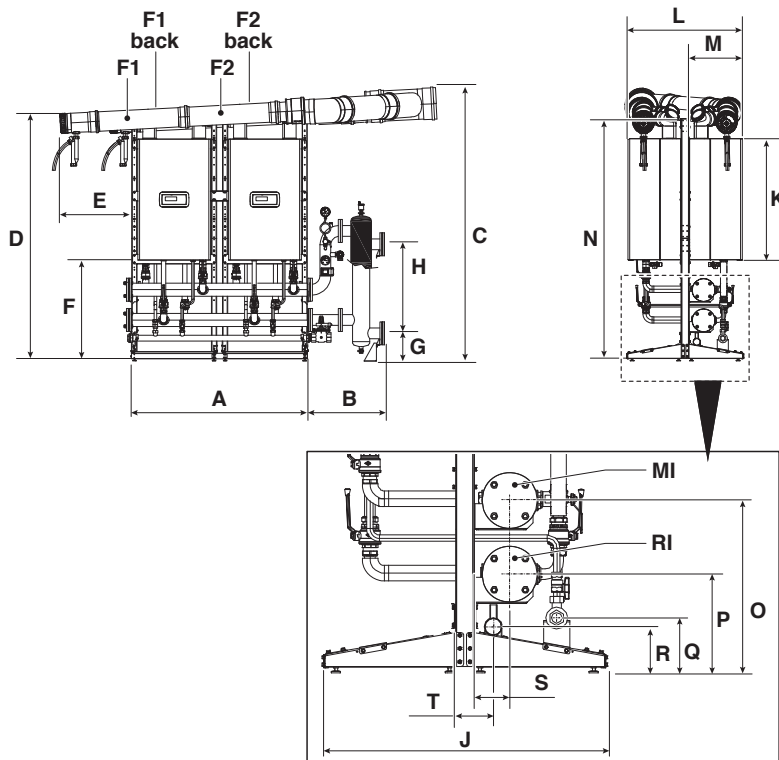

DESCRIPTION	Condexa PRO							
	57 P	70 P	90	100	115	135		
A	1494	1494	1494	1494	1494	1494	mm	
B	3"	591	591	591	591	591	mm	
	5"	1159	1159	1159	1159	1159	mm	
C	2260	2260	2260	2260	2430	2430	mm	
D	2051	2051	2051	2051	2221	2221	mm	
E	594	594	594	594	594	594	mm	
F	834	834	834	834	834	834	mm	
G	3"	230	230	230	230	230	mm	
	5"	N.A.	N.A.	N.A.	N.A.	N.A.	337	mm
H	3"	735	735	735	735	735	mm	
	5"	N.A.	N.A.	N.A.	N.A.	N.A.	850	mm
J	969	969	969	969	969	969	mm	
K	1010	1010	1010	1010	1173	1173	mm	
L	942	942	942	942	942	942	mm	
M	436	436	436	436	436	436	mm	
N	1999	1999	1999	1999	1999	1999	mm	
O	584	584	584	584	584	584	mm	
P	334	334	334	334	334	334	mm	
Q	186	186	186	186	186	186	mm	
R	156	156	156	156	156	156	mm	
S	121	121	121	121	121	121	mm	
T	137	137	137	137	137	137	mm	
F1	∅ 160	∅ 160	∅ 160	∅ 160	∅ 160	∅ 160	mm	
F1 back	∅ 160	∅ 160	∅ 160	∅ 160	∅ 160	∅ 160	mm	
F2	∅ 160	∅ 160	∅ 160	∅ 160	∅ 160	∅ 160	mm	
F2 back	∅ 160	∅ 160	∅ 160	∅ 160	∅ 160	∅ 160	mm	
RI	3 modules			∅ 3"			∅ 3"	inch
	4 modules			∅ 3"			∅ 5"	inch
MI	3 modules			∅ 3"			∅ 3"	inch
	4 modules			∅ 3"			∅ 5"	inch

1.3.12 B2B (BACK TO BACK) layout with 5 and 6 modules

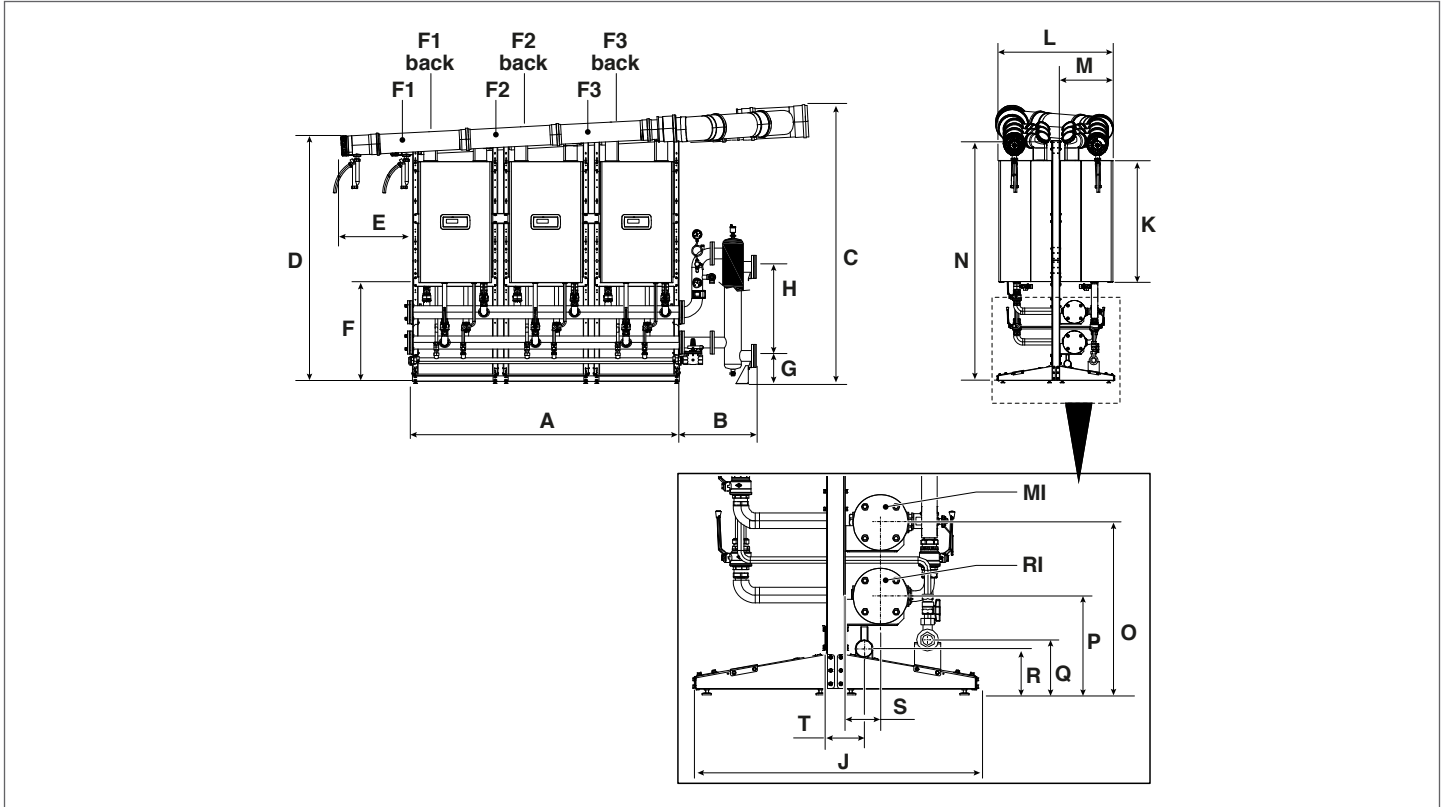

DESCRIPTION	Condexa PRO						
	57 P	70 P	90	100	115	135	
A	2242	2242	2242	2242	2242	2242	mm
B	3"	591	591	591	591	591	mm
	5"	1159	1159	1159	1159	1159	mm
C	2299	2299	2299	2299	2469	2469	mm
D	2051	2051	2051	2051	2221	2221	mm
E	594	594	594	594	594	594	mm
F	834	834	834	834	834	834	mm
G	3"	230	230	230	N.A.	N.A.	mm
	5"	N.A.	N.A.	337	337	337	mm
H	3"	735	735	735	N.A.	N.A.	mm
	5"	N.A.	N.A.	850	850	850	mm
J	969	969	969	969	969	969	mm
K	1010	1010	1010	1010	1173	1173	mm
L	942	942	942	942	942	942	mm
M	436	436	436	436	436	436	mm
N	1999	1999	1999	1999	1999	1999	mm
O	584	584	584	584	584	584	mm
P	334	334	334	334	334	334	mm
Q	186	186	186	186	186	186	mm
R	156	156	156	156	156	156	mm
S	121	121	121	121	121	121	mm
T	137	137	137	137	137	137	mm
F1	∅ 160	∅ 160	∅ 160	∅ 160	∅ 160	∅ 160	mm
F1 back	∅ 160	∅ 160	∅ 160	∅ 160	∅ 160	∅ 160	mm
F2	∅ 160	∅ 160	∅ 160	∅ 160	∅ 160	∅ 160	mm
F2 back	∅ 160	∅ 160	∅ 160	∅ 160	∅ 160	∅ 160	mm
F3	∅ 160	∅ 160	∅ 160	∅ 160	∅ 160	∅ 160	mm
F3 back	∅ 160	∅ 160	∅ 160	∅ 160	∅ 160	∅ 160	mm
RI	5 modules	∅ 3"		∅ 3"		∅ 5"	inch
	6 modules	∅ 3"		∅ 5"		∅ 5"	inch
MI	5 modules	∅ 3"		∅ 3"		∅ 5"	inch
	6 modules	∅ 3"		∅ 5"		∅ 5"	inch

1.3.13 B2B (BACK TO BACK) layout with 7 and 8 modules

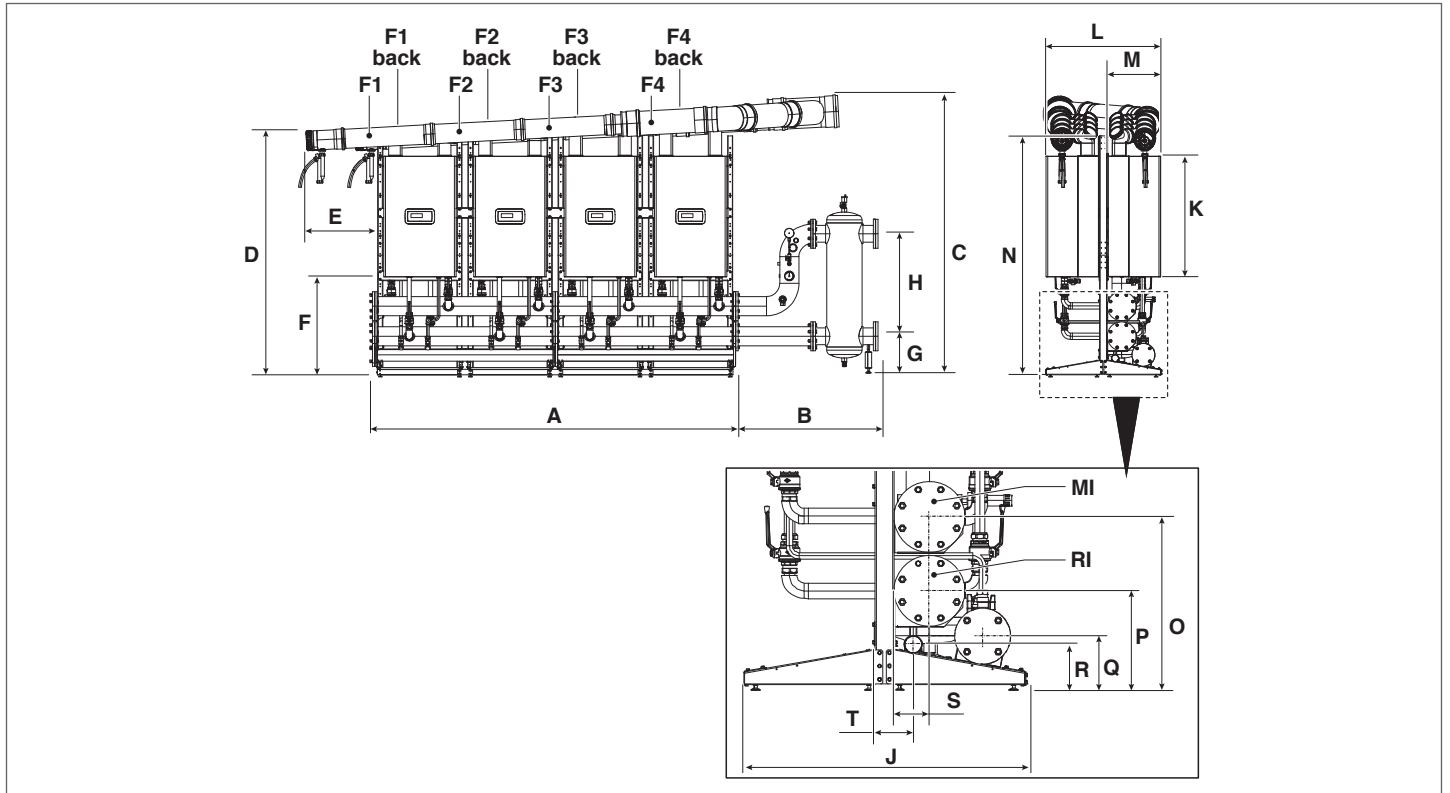

DESCRIPTION	Condexa PRO						
	57 P	70 P	90	100	115	135	
A	2988	2988	2988	2988	2988	2988	mm
B	3"	591	591	591	591	591	mm
	5"	1159	1159	1159	1159	1159	mm
C	2339	2339	2339	2339	2509	2509	mm
D	2051	2051	2051	2051	2221	2221	mm
E	594	594	594	594	594	594	mm
F	834	834	834	834	834	834	mm
G	3"	230	230	N.A.	N.A.	N.A.	mm
	5"	N.A.	337	337	337	337	mm
H	3"	735	735	N.A.	N.A.	N.A.	mm
	5"	N.A.	850	850	850	850	mm
J	969	969	969	969	969	969	mm
K	1010	1010	1010	1010	1173	1173	mm
L	942	942	942	942	942	942	mm
M	436	436	436	436	436	436	mm
N	1999	1999	1999	1999	1999	1999	mm
O	584	584	584	584	584	584	mm
P	334	334	334	334	334	334	mm
Q	186	186	186	186	186	186	mm
R	156	156	156	156	156	156	mm
S	121	121	121	121	121	121	mm
T	137	137	137	137	137	137	mm
F1	∅ 160	∅ 160	∅ 160	∅ 160	∅ 160	∅ 160	mm
F1 back	∅ 160	∅ 160	∅ 160	∅ 160	∅ 160	∅ 160	mm
F2	∅ 160	∅ 160	∅ 160	∅ 160	∅ 160	∅ 160	mm
F2 back	∅ 160	∅ 160	∅ 160	∅ 160	∅ 160	∅ 160	mm
F3	∅ 160	∅ 160	∅ 160	∅ 160	∅ 160	∅ 160	mm
F3 back	∅ 160	∅ 160	∅ 160	∅ 160	∅ 160	∅ 160	mm
F4	∅ 160	∅ 160	∅ 160	∅ 160	∅ 160	∅ 200	mm
F4 back	∅ 160	∅ 160	∅ 160	∅ 160	∅ 160	∅ 200	mm
RI	7 modules	∅ 3"	∅ 3"		∅ 5"		inch
	8 modules	∅ 3"	∅ 5"		∅ 5"		inch
MI	7 modules	∅ 3"	∅ 3"		∅ 5"		inch
	8 modules	∅ 3"	∅ 5"		∅ 5"		inch

1.3.14 B2B (BACK TO BACK) layout with 9 and 10 modules

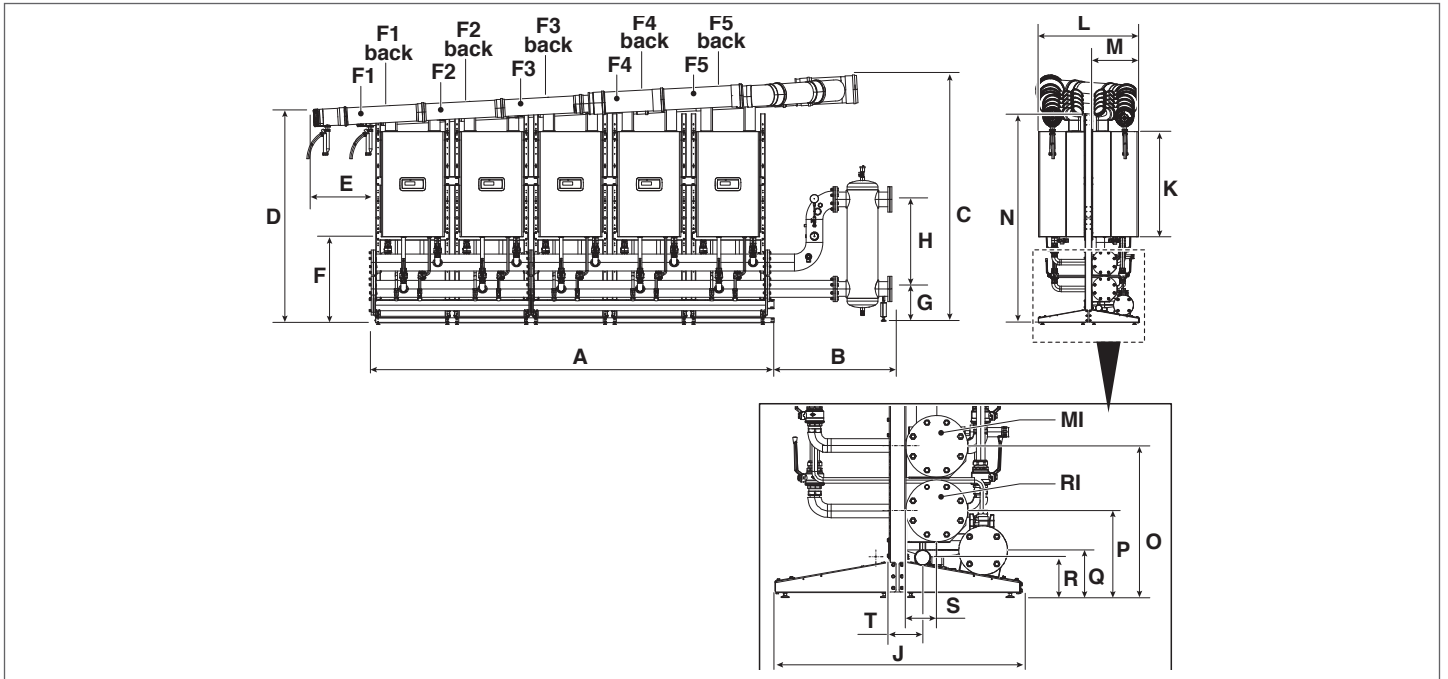

DESCRIPTION	Condexa PRO							
	57 P	70 P	90	100	115	135		
A	3736	3736	3736	3736	3736	N.A.	mm	
B	1159	1159	1159	1159	1159	N.A.	mm	
C	2367	2367	2367	2367	2537	N.A.	mm	
D	2051	2051	2051	2051	2221	N.A.	mm	
E	594	594	594	594	594	N.A.	mm	
F	834	834	834	834	834	N.A.	mm	
G	9 modules	3"	N.A.	N.A.	N.A.	N.A.	N.A.	mm
		5"	337	337	337	337	N.A.	mm
	10 modules	3"	N.A.	N.A.	N.A.	N.A.	N.A.	mm
		5"	337	337	337	337	N.A.	mm
H	9 modules	3"	N.A.	N.A.	N.A.	N.A.	N.A.	mm
		5"	850	850	850	850	N.A.	mm
	10 modules	3"	N.A.	N.A.	N.A.	N.A.	N.A.	mm
		5"	850	850	850	850	N.A.	mm
J	969	969	969	969	969	N.A.	mm	
K	1010	1010	1010	1010	1173	N.A.	mm	
L	942	942	942	942	942	N.A.	mm	
M	436	436	436	436	436	N.A.	mm	
N	1999	1999	1999	1999	1999	N.A.	mm	
O	584	584	584	584	584	N.A.	mm	
P	334	334	334	334	334	N.A.	mm	
Q	186	186	186	186	186	N.A.	mm	
R	156	156	156	156	156	N.A.	mm	
S	121	121	121	121	121	N.A.	mm	
T	137	137	137	137	137	N.A.	mm	
F1	∅ 160	∅ 160	∅ 160	∅ 160	∅ 160	N.A.	mm	
F1 back	∅ 160	∅ 160	∅ 160	∅ 160	∅ 160	N.A.	mm	
F2	∅ 160	∅ 160	∅ 160	∅ 160	∅ 160	N.A.	mm	
F2 back	∅ 160	∅ 160	∅ 160	∅ 160	∅ 160	N.A.	mm	
F3	∅ 160	∅ 160	∅ 160	∅ 160	∅ 160	N.A.	mm	
F3 back	∅ 160	∅ 160	∅ 160	∅ 160	∅ 160	N.A.	mm	
F4	∅ 160	∅ 160	∅ 160	∅ 160	∅ 160	N.A.	mm	
F4 back	∅ 160	∅ 160	∅ 160	∅ 160	∅ 160	N.A.	mm	
F5	∅ 160	∅ 160	∅ 200	∅ 200	∅ 200	N.A.	mm	
F5 back	∅ 160	∅ 160	∅ 200	∅ 200	∅ 200	N.A.	mm	
RI	9 modules					∅ 5"	inch	
	10 modules					∅ 5"	inch	
MI	9 modules					∅ 5"	inch	
	10 modules					∅ 5"	inch	

## 1.4 Installation premises



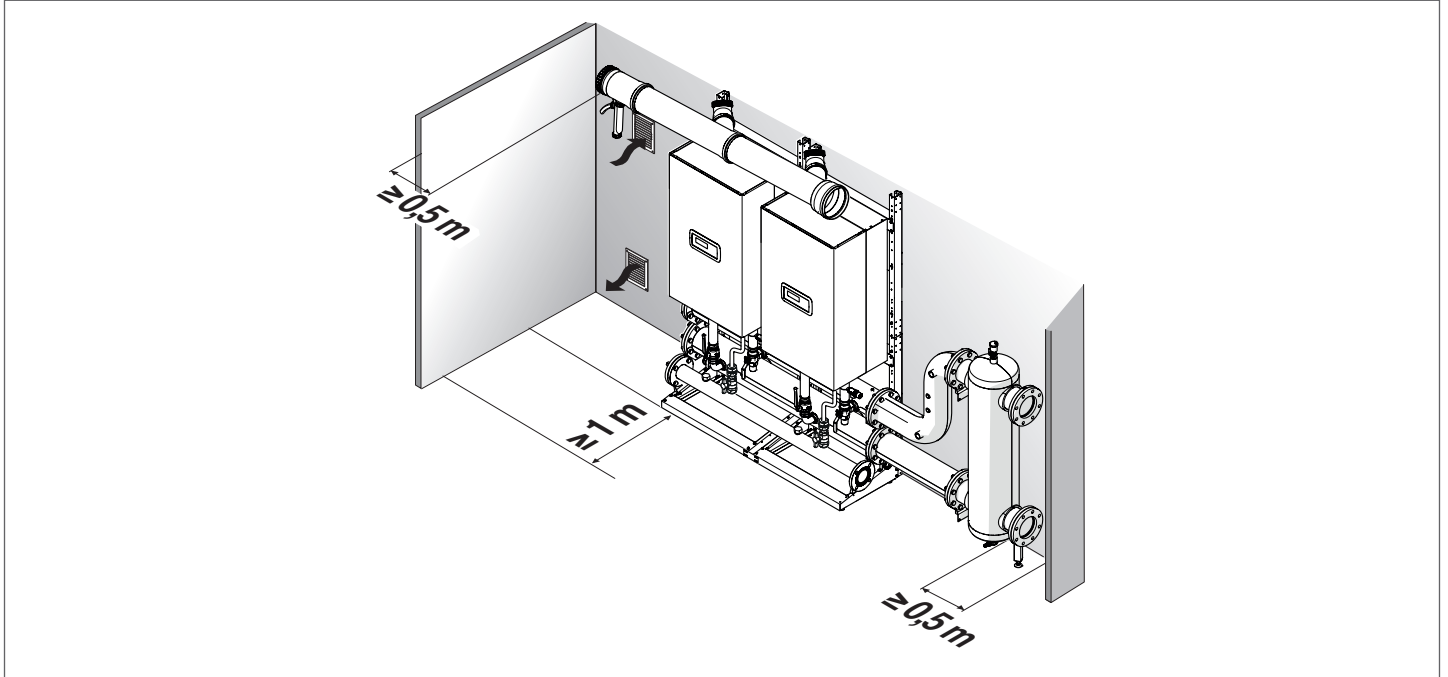

The module must be installed in premises used exclusively for the latter conforming to standards and legislation in force and where combustion exhaust products and combustion air intake is conveyed out of said premises. Where combustion air is instead taken from the installation premises then the latter must be equipped with suitably sized vents conforming to standards.

### Space required for in line layout (FRONT)

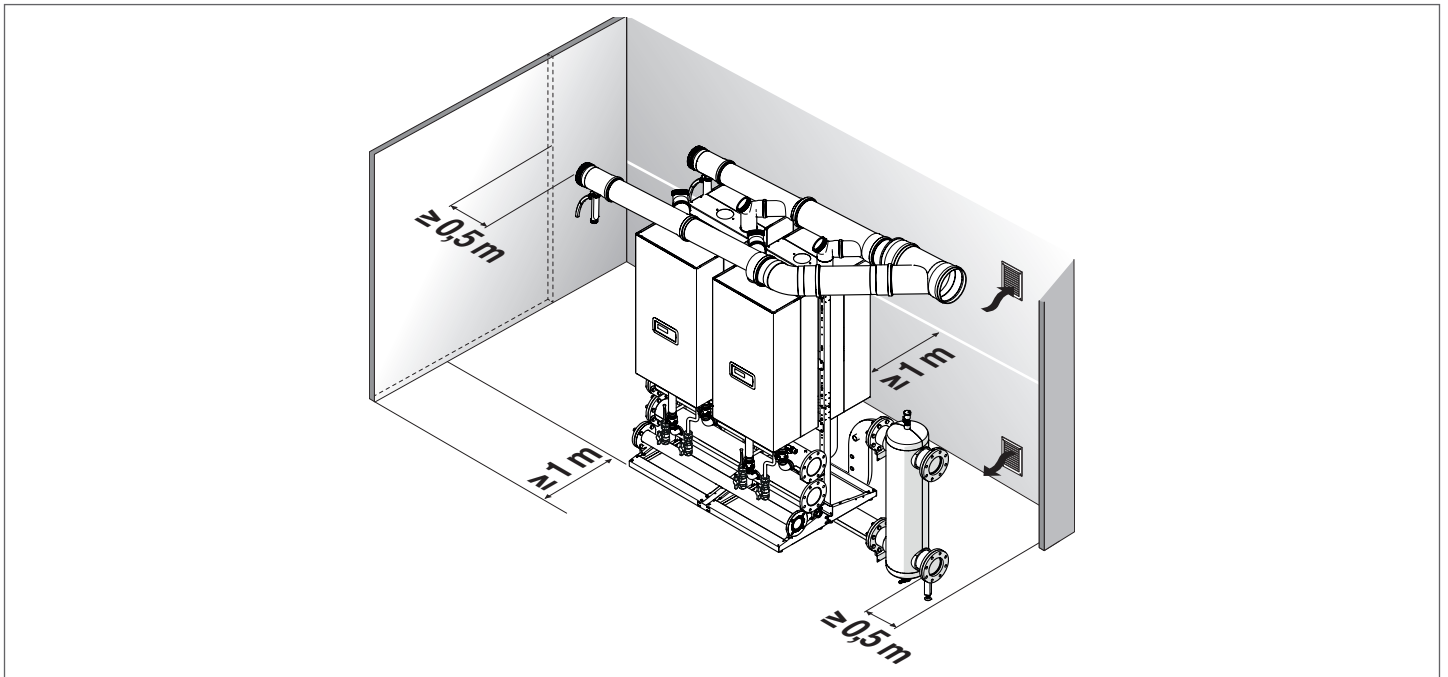

### Space required for back-to-back layout (B2B – BACK TO BACK)



-  When installing the boiler, allow sufficient space around it to access all safety and control devices and to permit easy maintenance.
-  The height of the installation room must meet the fire-prevention requirements and current regulations in force in the country of installation.
-  Check that the electrical protection rating of the module is sufficient for the characteristics of the installation room.
-  If the modules are powered by combustible gas with a specific weight exceeding that of air, the electrical parts must be positioned at a height exceeding 500 mm from the ground.

## 1.5 Air vent

The rooms must be equipped with one or more permanent air vents positioned on external walls, ensuring that the all regulations established in the country of installation are complied with.

For Italy:

The air vents must not have a surface area less than the minimum value indicated in the table (expressed in cm<sup>2</sup>):

### Rooms above the ground

Model	Condexa PRO					
	57 P	70 P	90	100	115	135
No. of Boilers	MINIMUM DIMENSION OF AIR VENT (cm <sup>2</sup> )					
2	3000*	3000*	3000*	3000*	3000*	3000*
3	3000*	3000*	3000*	3000*	3360*	3930*
4	3000*	3000*	3600*	3880*	4480*	5240
5	3000*	3400*	4500*	4850*	5600	6550
6	3420*	4080*	5400	5820	6720	7860
7	3990*	4760*	6300	6790	7840	9170
8	4560*	5440	7200	7760	8960	10480
9	5130	6120	8100	8730	10080	ND
10	5700	6800	9000	9700	11200	ND

(\*) 5000 cm<sup>2</sup> in the case of G30-G31

### Rooms below ground, down to a distance of - 5 m from the reference floor level:

Model	Condexa PRO					
	57 P	70 P	90	100	115	135
No. of Boilers	MINIMUM DIMENSION OF AIR VENT (cm <sup>2</sup> )					
2	3000	3000	3000	3000	3360	3930
3	3000	3060	4050	4365	5040	5895
4	3420	4080	5400	5820	6720	7860
5	4275	5100	6750	7275	8400	9825
6	5130	6120	8100	8730	10080	11790
7	5985	7140	9450	10185	11760	13755
8	6840	8160	10800	11640	13440	15720
9	7695	9180	12150	13095	15120	ND
10	8550	10200	13500	14550	16800	ND

### Rooms below ground, at a distance of between - 5 m and - 10 m below the reference floor level (with a minimum of 5000 cm<sup>2</sup>):

Model	Condexa PRO					
	57 P	70 P	90	100	115	135
No. of Boilers	MINIMUM DIMENSION OF AIR VENT (cm <sup>2</sup> )					
2	5000	5000	5000	5000	5000	5240
3	5000	5000	5400	5820	6720	7860
4	5000	5440	7200	7760	8960	10480
5	5700	6800	9000	9700	11200	13100
6	6840	8160	10800	11640	13440	15720
7	7980	9520	12600	13580	15680	18340
8	9120	10880	14400	15520	17920	20960
9	10260	12240	16200	17460	20160	ND
10	11400	13600	18000	19400	22400	ND

⊖ It is not permitted to install systems for relative gas density greater than 0.8 (G30-G31) in rooms with flooring below the natural ground level.

⚠ The aeration surface area must not in any case be less than 3000 cm<sup>2</sup> or 5000 cm<sup>2</sup> if using gas with a density exceeding 0.8 (G30-G31).

⚠ The air vents in rooms with appliances supplied with gas must meet all fire prevention requirements, in particular Ministerial Decree of 12th April 2011 and subsequent updates.

## 2 INSTALLATION

### 2.1 Preliminary installation measures

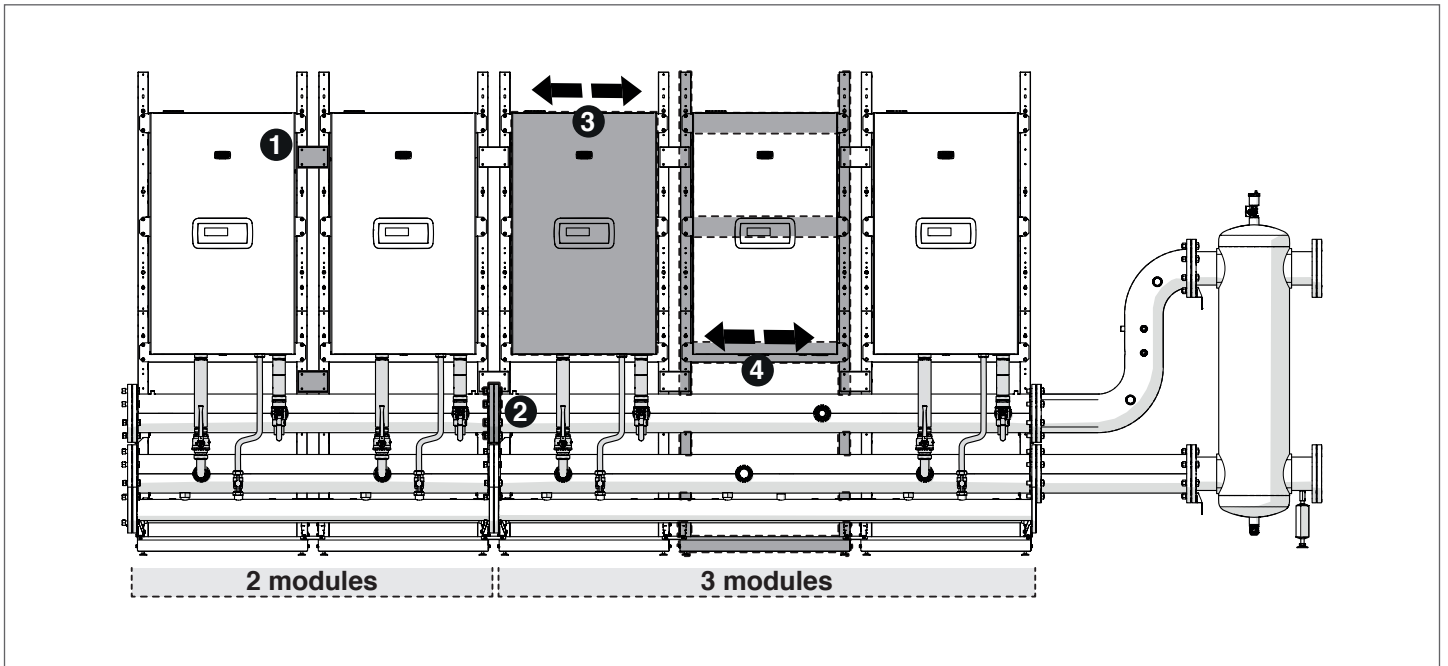

To correctly install the modules, the installer must take into consideration a series of tolerances on the installation distances as established during the design stage.

In particular:

- 1 the plates for securing the frames have slots and must only be secured after having fitted the manifolds.
- 2 if making connections between manifolds, tighten the flange to ensure that the seal adheres and reduce the clearance on the total length of the manifolds.
- 3 the module can slide (right-left) on the supporting bracket to facilitate any adjustments which need to be made during the installation stage of the hydraulic ramps.
- 4 in the case of installations with a manifold for 3 modules, the central frame has a greater tolerance.

## 2.2 Assembly of the FRAMES

Assembly of the cascade frame in-line. Components included in code 20131663

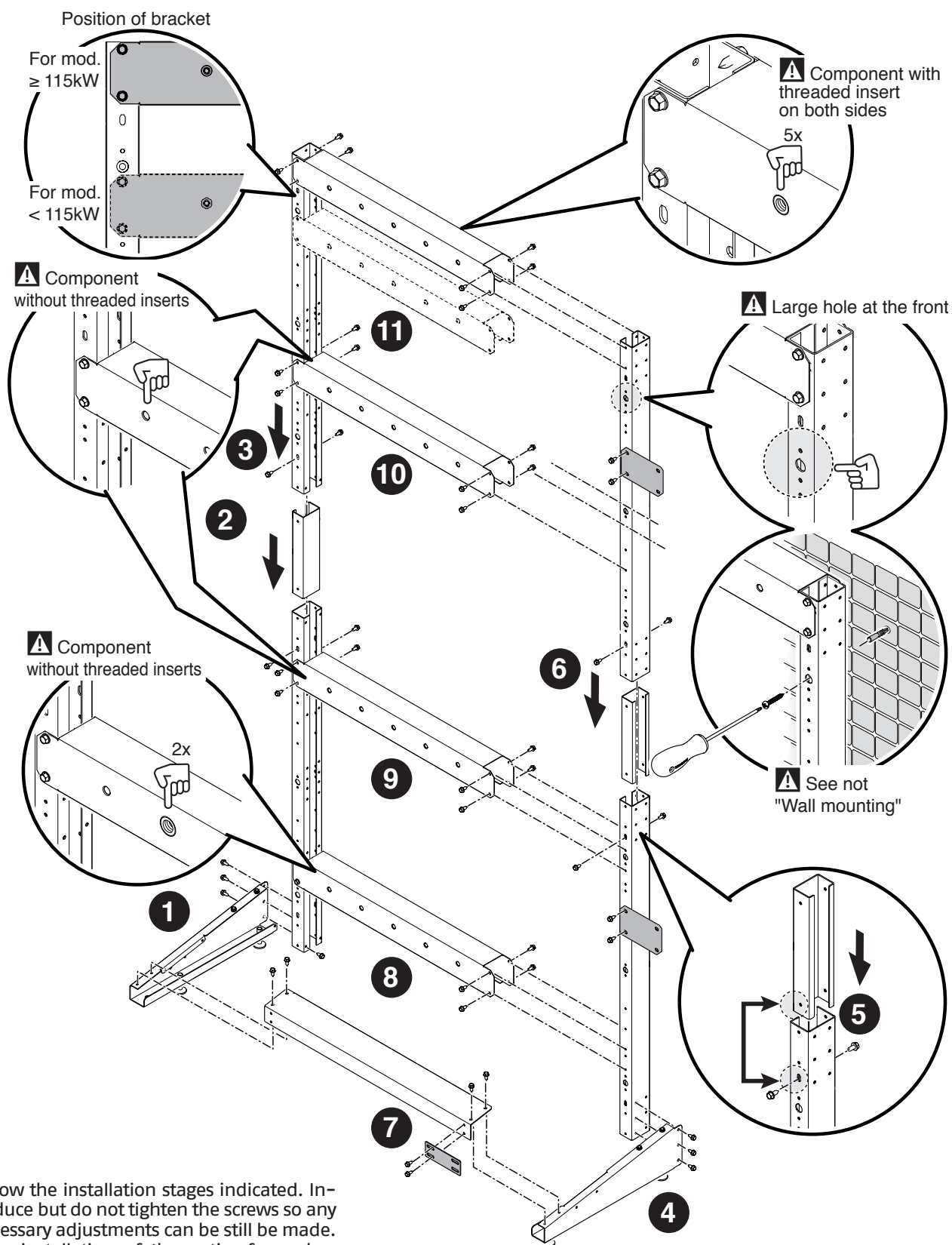

**⚠** Follow the installation stages indicated. Introduce but do not tighten the screws so any necessary adjustments can be still be made. Once installation of the entire frame has been completed, only then can the screws be fully tightened.

Assembly of the cascade frame B2B - BACK TO BACK. Components included in code 20131664.

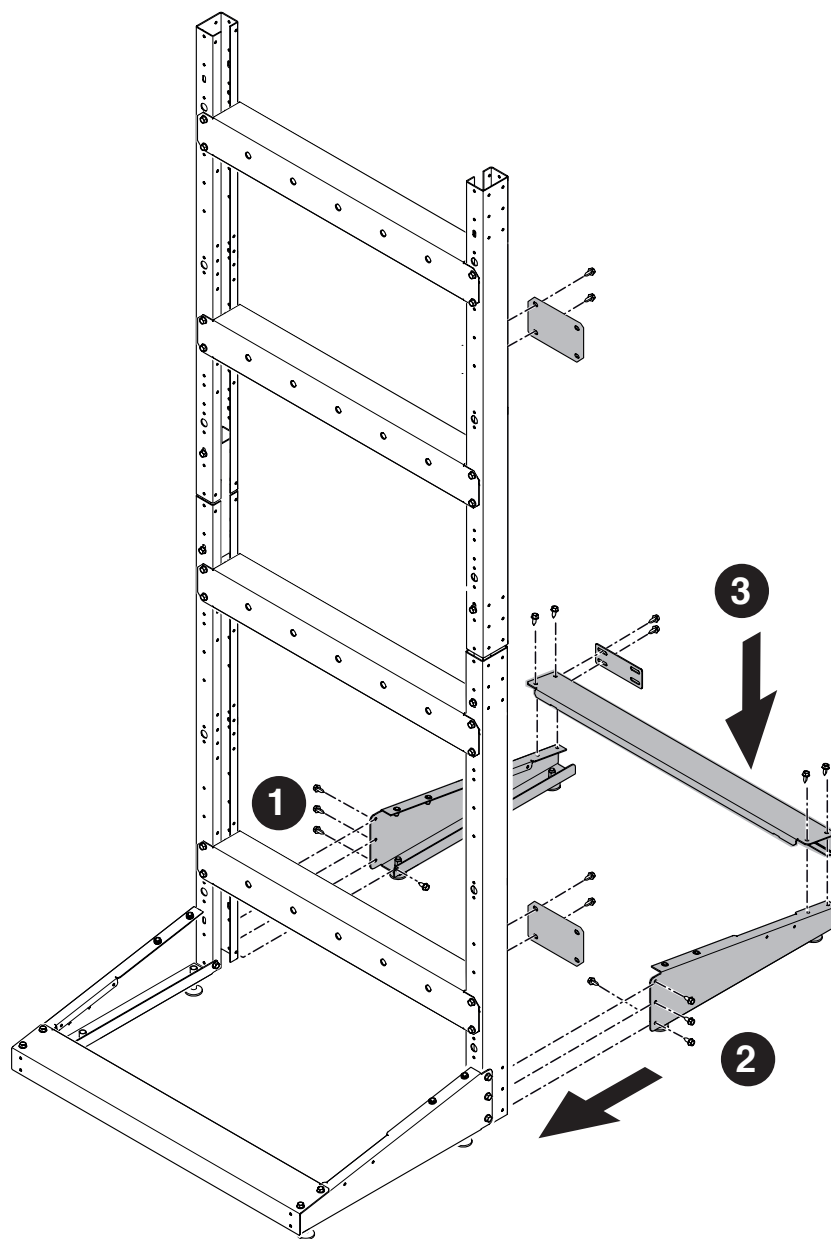

**⚠** Follow the installation stages indicated. Introduce but do not tighten the screws so any necessary adjustments can be still be made. Once installation of the entire frame has been completed, only then can the screws be fully tightened.

Fastening the frames to each other.

Cascade installation in-line

Cascade installation B2B

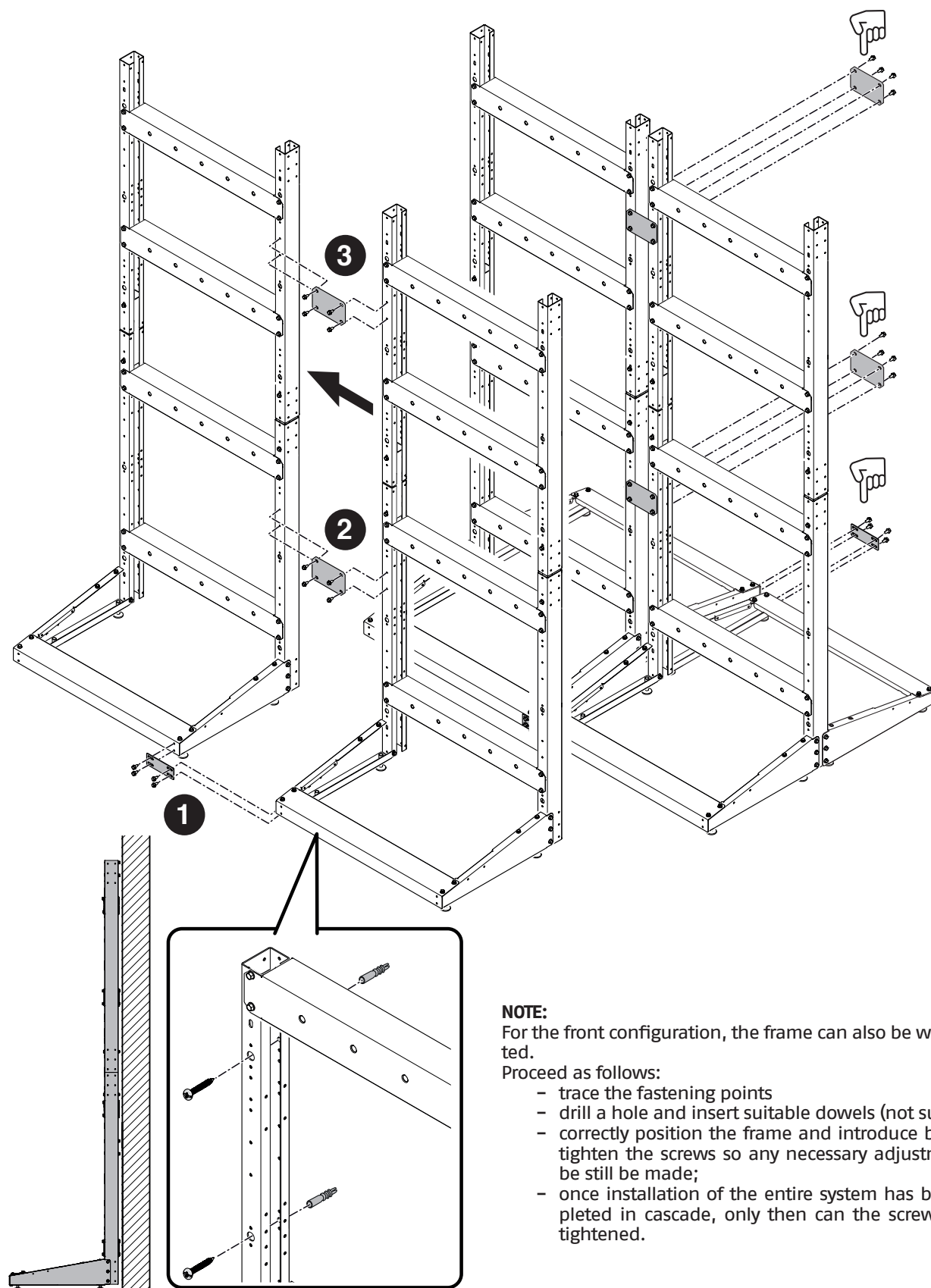

**NOTE:**

For the front configuration, the frame can also be wall mounted.

Proceed as follows:

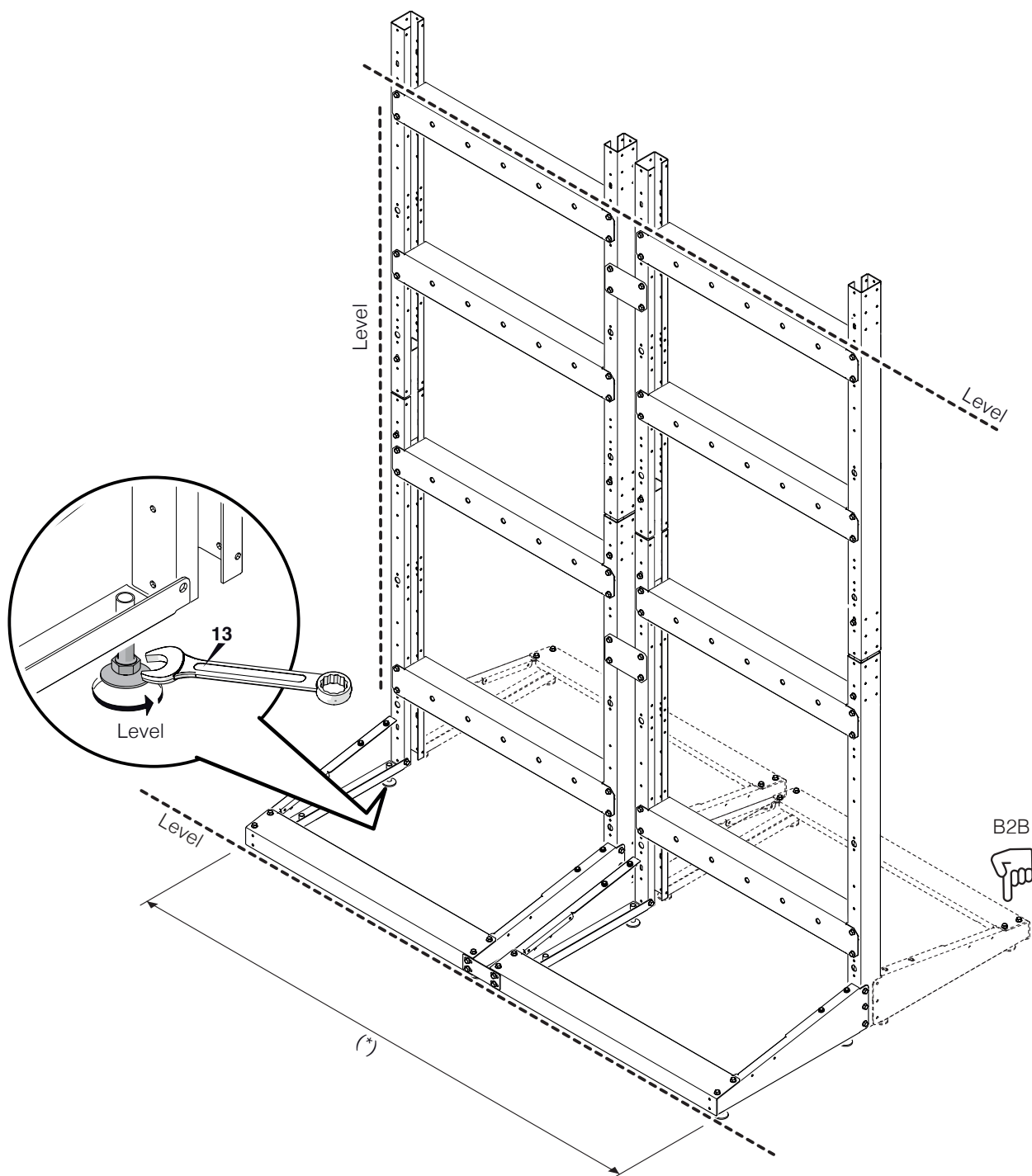

- trace the fastening points
- drill a hole and insert suitable dowels (not supplied);
- correctly position the frame and introduce but do not tighten the screws so any necessary adjustments can be still be made;
- once installation of the entire system has been completed in cascade, only then can the screws be fully tightened.

Adjusting the feet



(\*) check the measurements on the table of the dimensions present in the paragraph "System layout".

### Moving and removing the packing

-  Do not remove the cardboard used for packaging the appliance until it has reached the place of installation.
-  Before carrying out any transport operations or removing the packaging, ensure you are wearing suitable PPE and use tools and means which are appropriate for the dimensions and weight of the appliance.
-  This operations is to be carried out by more than one person, equipped with means which are suitably for the weight and dimensions of the appliance. Make sure that the weight of the package remains balanced during handling operations.

Proceed as follows to remove the packing:

- Remove the retainers which secure the package to the pallet
- Remove the cardboard
- Remove edge protectors (1)
- Remove the Styrofoam protection (2)
- Remove the protective bag (3).

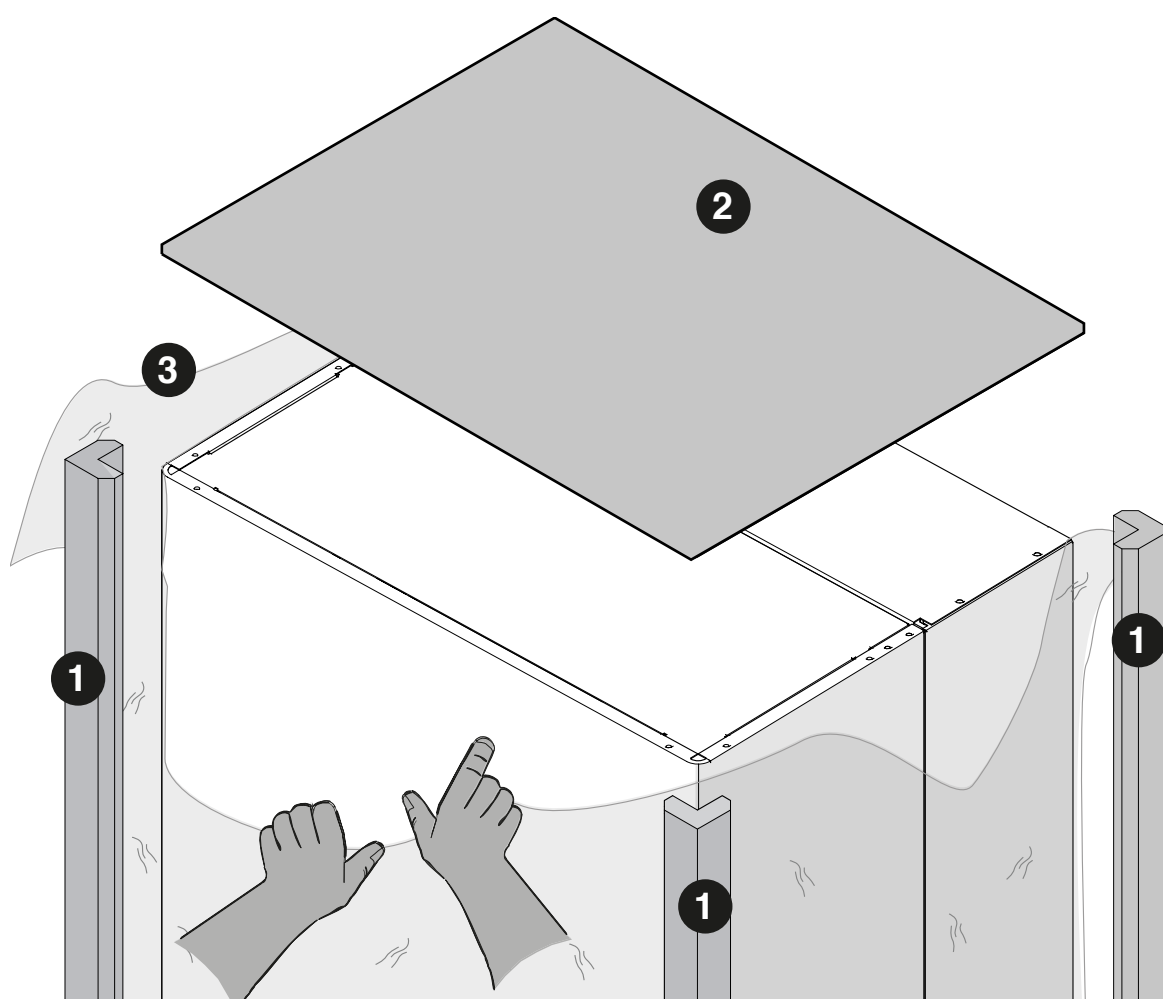

**Fitting the module support bracket**

The bracket is supplied together with the module.

**Cascade installation B2B**

**Cascade installation in-line**

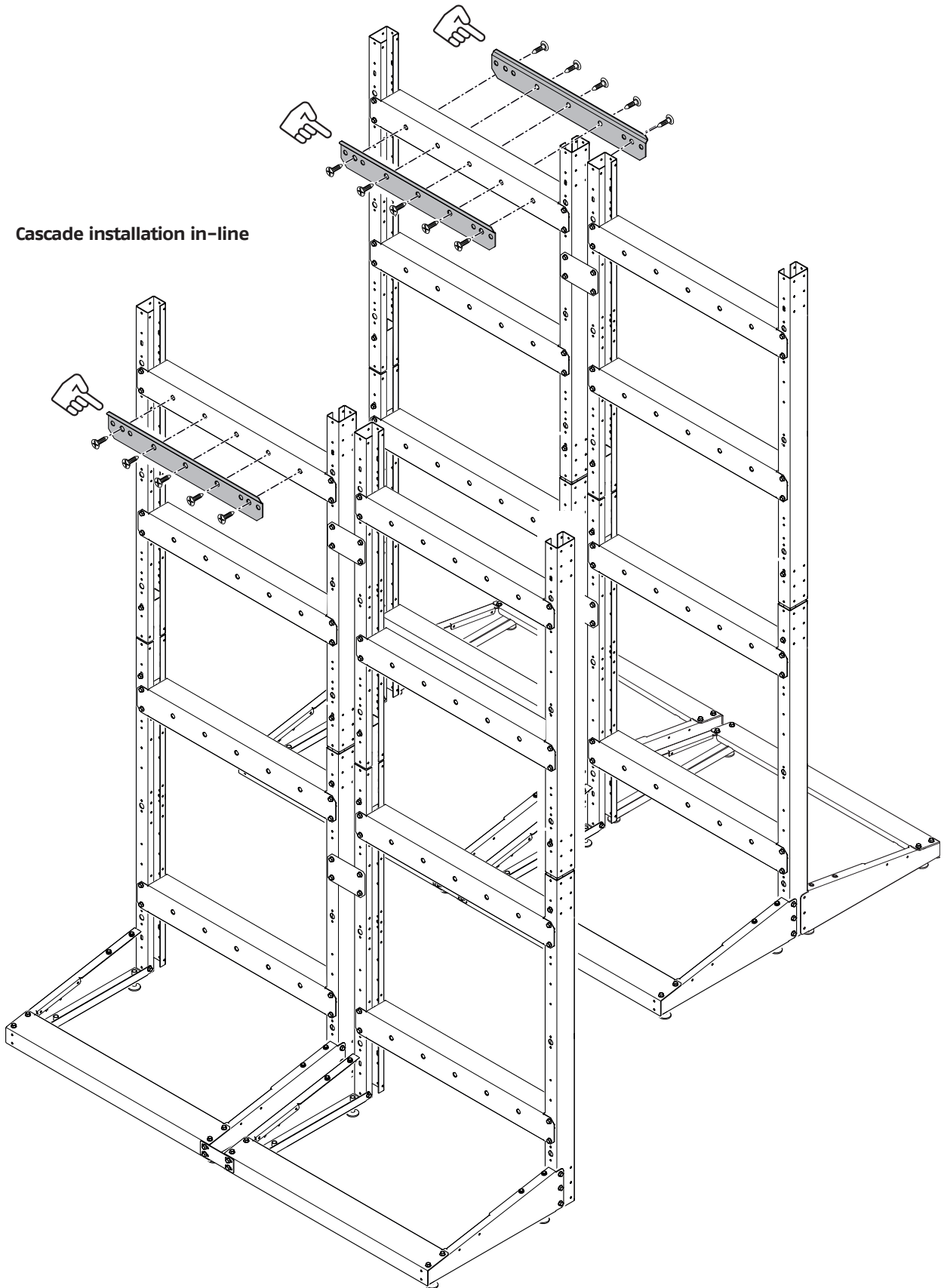

### Fitting the module onto the frame

- 1 Working together with other people, lift the module.
- 2 Correctly position the module on the bracket which was previously fitted onto the frame.

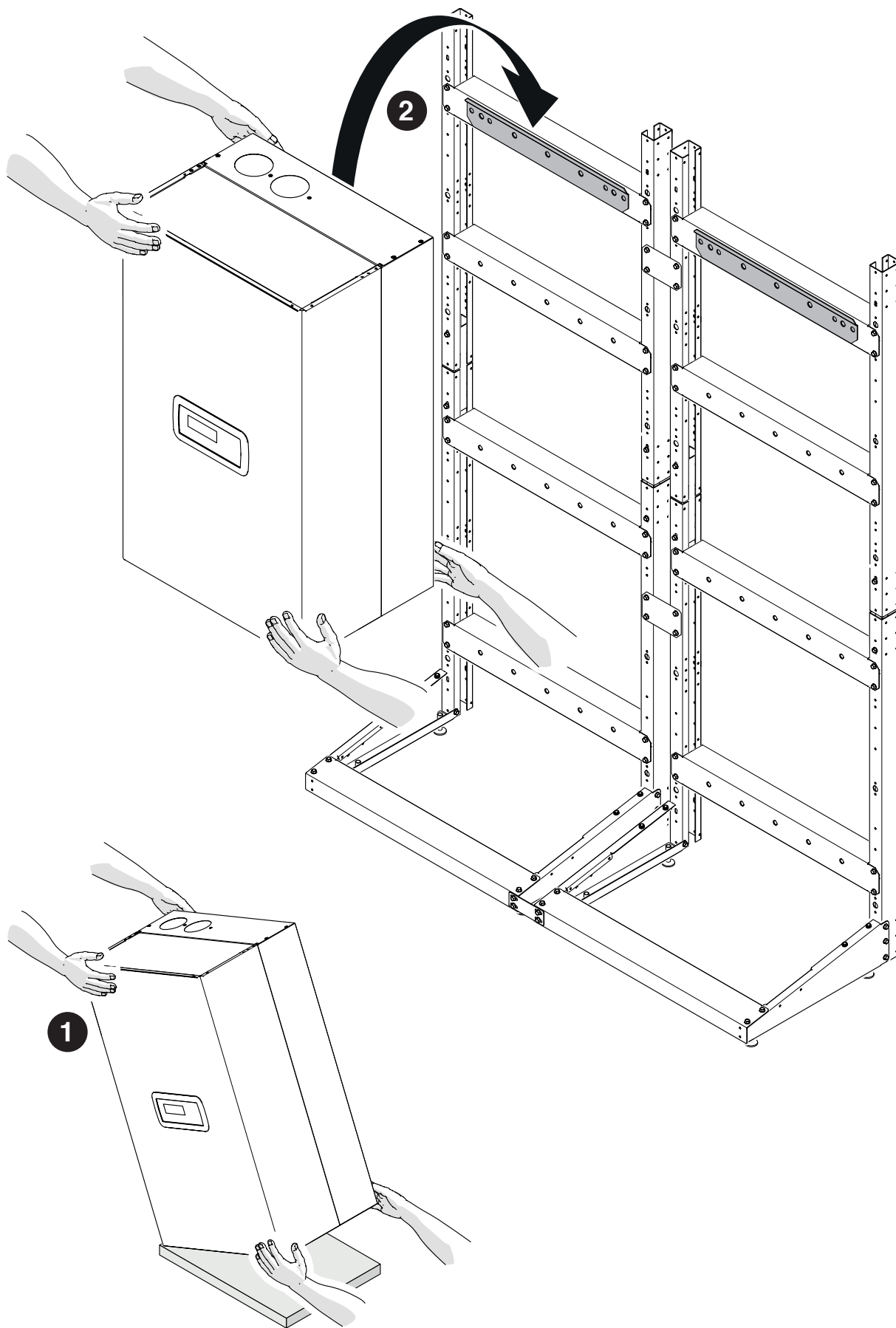

**Removing the front panels**

- 1 Remove the lock screw (A) and pull the front panel outwards.
- 2 Push the front panel upwards to release it from the points (B).

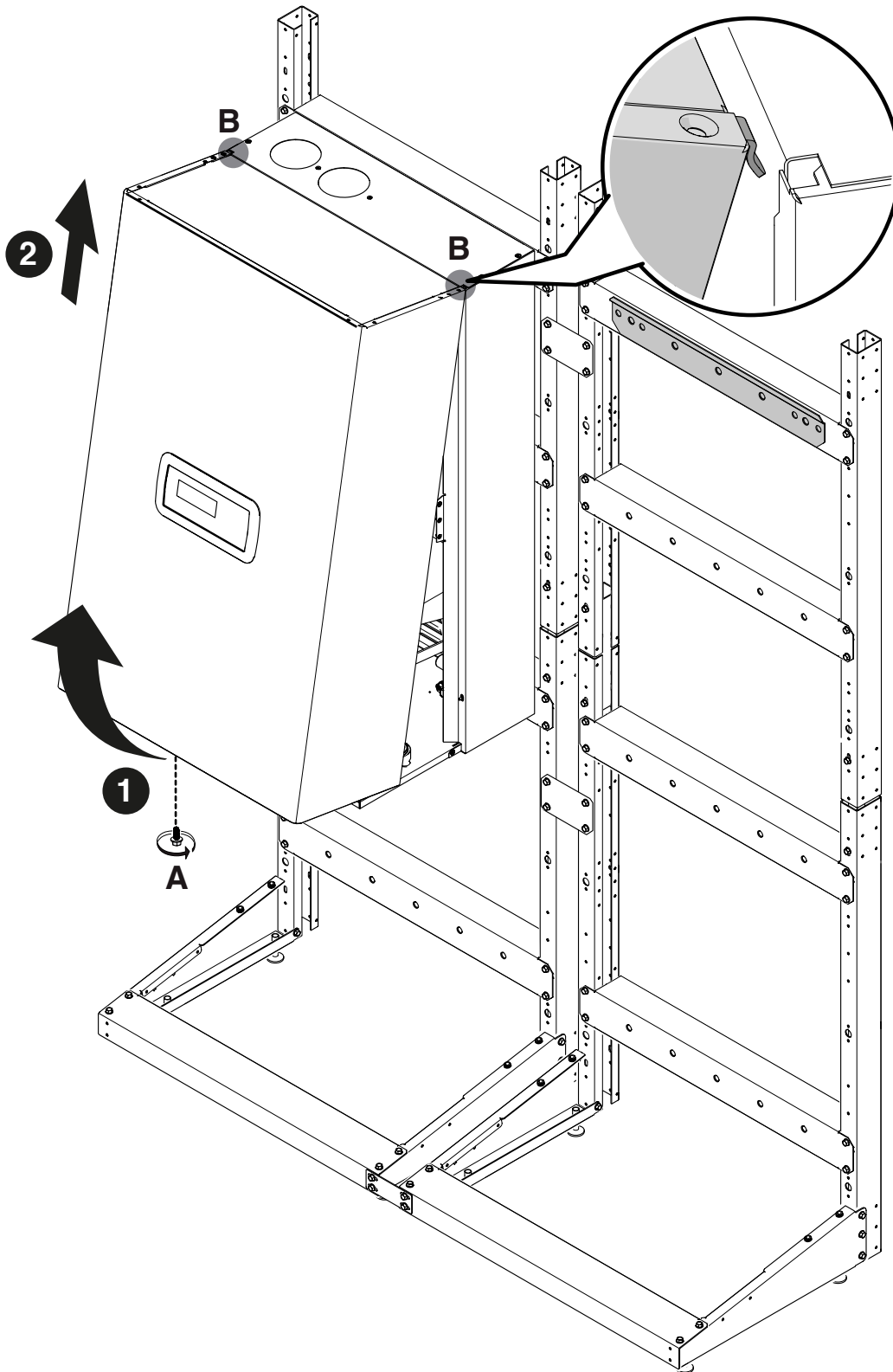

To fit the front cover, see Chapter "Commissioning and maintenance".

## 2.3 Positioning the CONDENSATE PIPES

### Installation of the condensate outlet pipe. Components included in code 20130222 - 20130223

The figure refers to an installation with 2 modules in line or 3/4 modules B2B.

- 1 Position the seal on the side of the condensate outlet.
- 2 Position the plug on the opposite side of the condensate outlet.

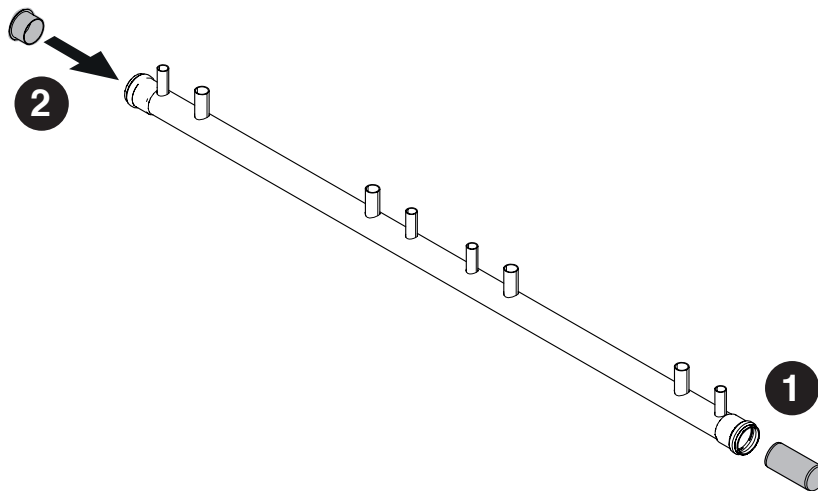

- 3 Position the condensate outlet pipe on the frames.
- 4 Secure it using the designated brackets.

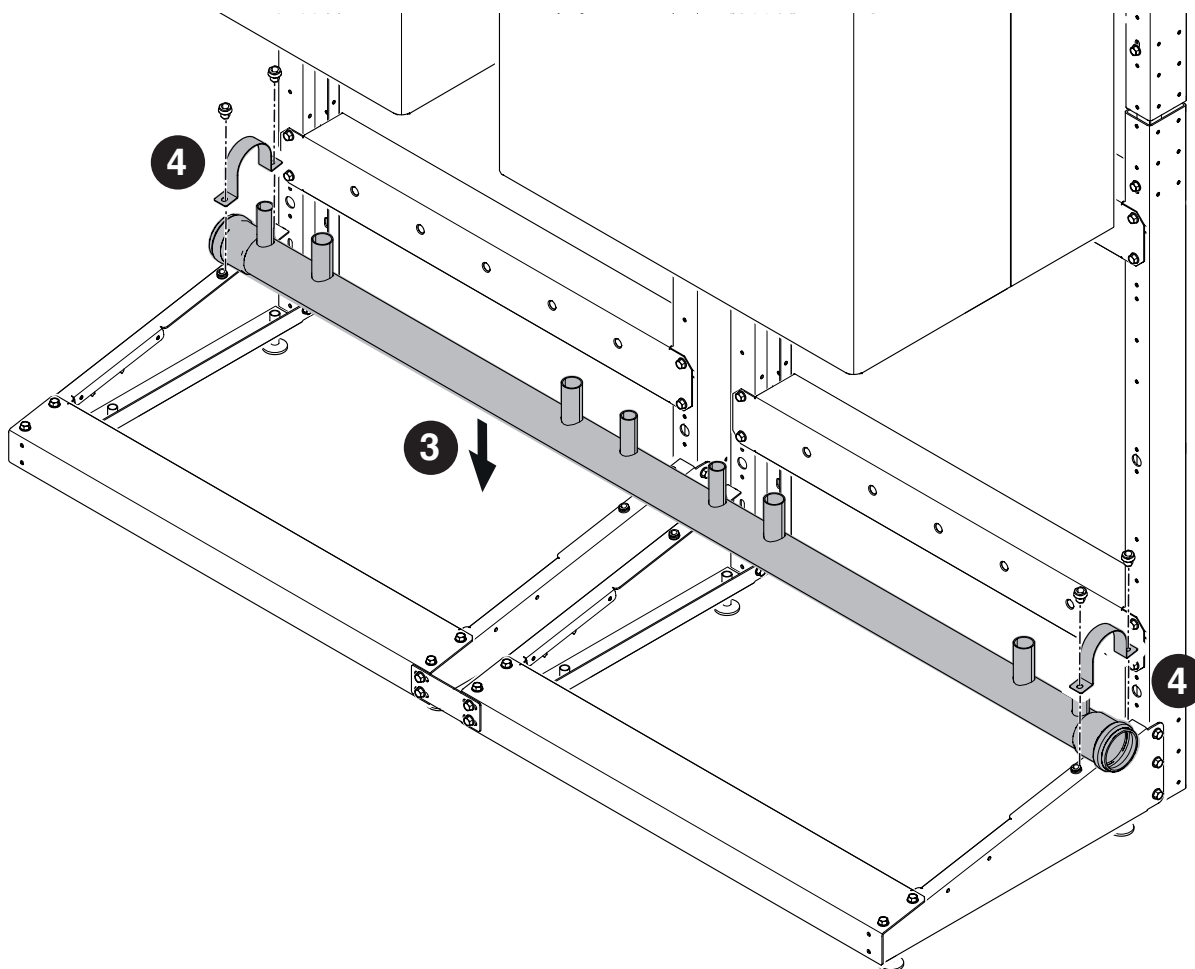

## 2.4 Positioning the 3" MANIFOLDS

**Assembly of the gas, delivery and return manifolds. Components included in code 20133220 - 20130220 - 20130221**  
 The figure refers to an installation with 2 modules in line or 3/4 modules B2B.

- 1 Secure the left support bracket.
- 2 Secure the right support bracket.
- 3 Position the RETURN manifold.

 Make sure that the delivery and return manifolds are not inverted.

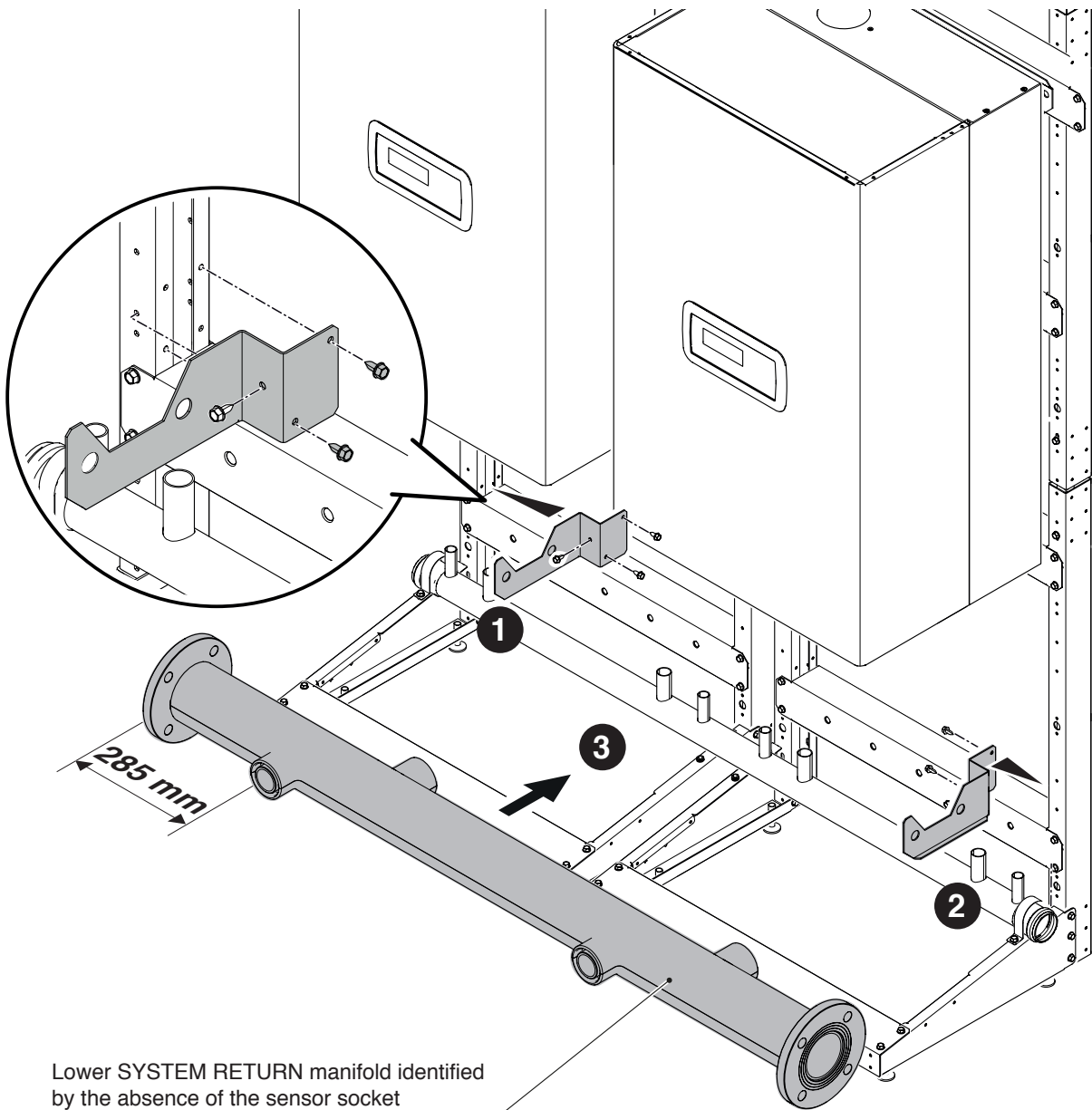

- 4 Secure the left support bracket.
- 5 Secure the right support bracket.
- 6 Position the DELIVERY manifold.

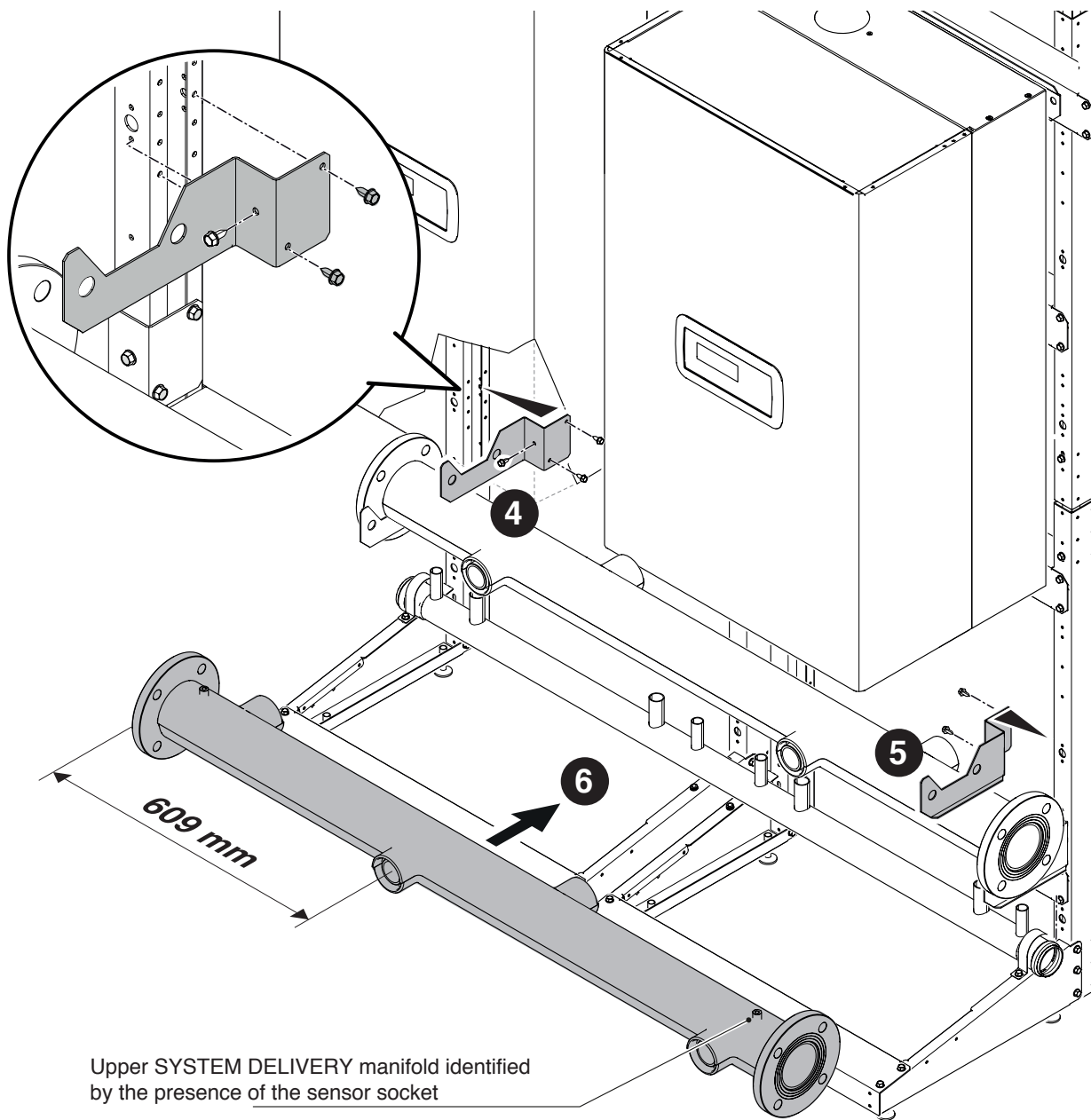

- 7 Position the GAS manifold.
- 8 Secure the GAS manifold to the frame.

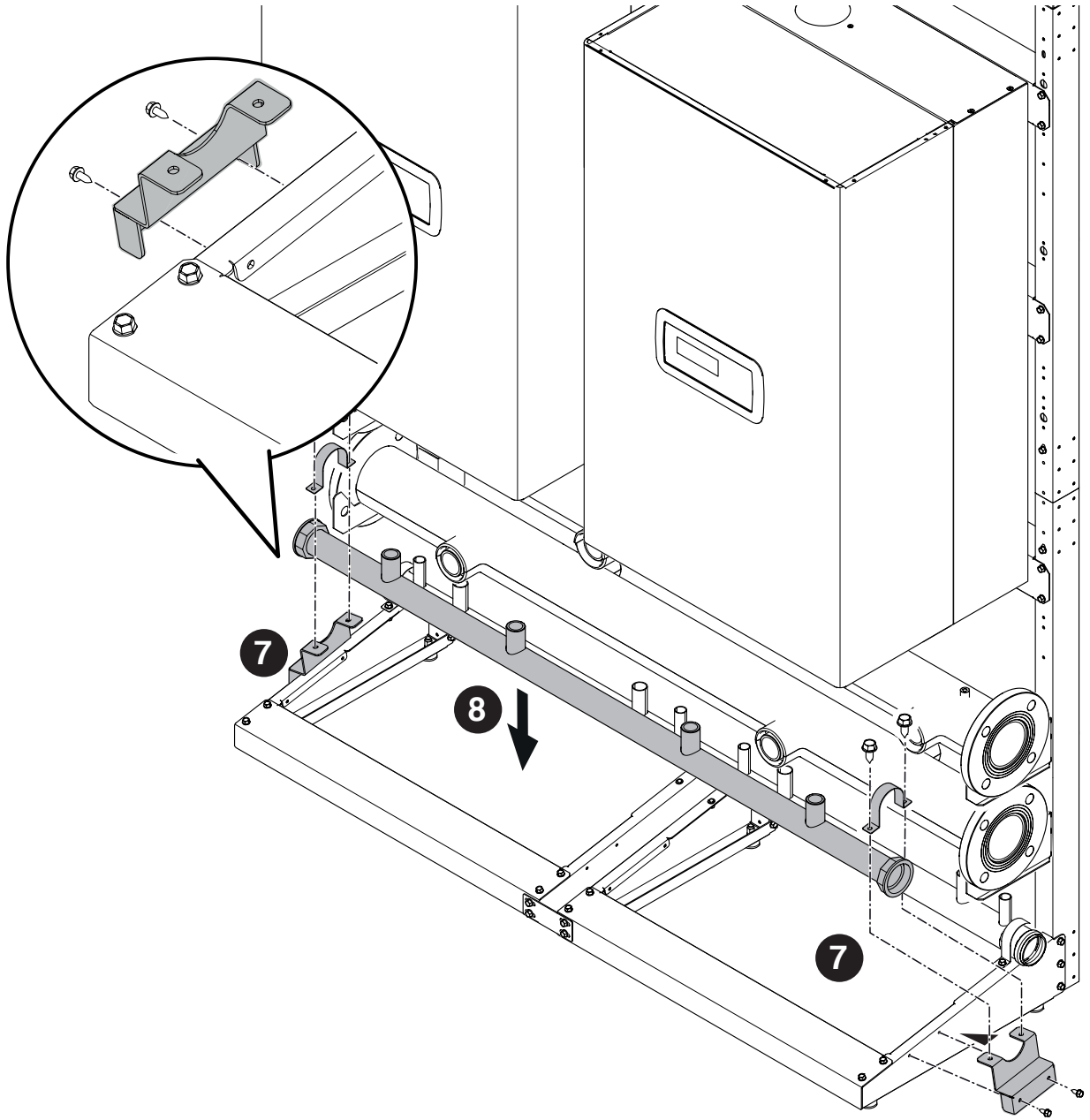

9 Position the manifold closing plugs from the required side.

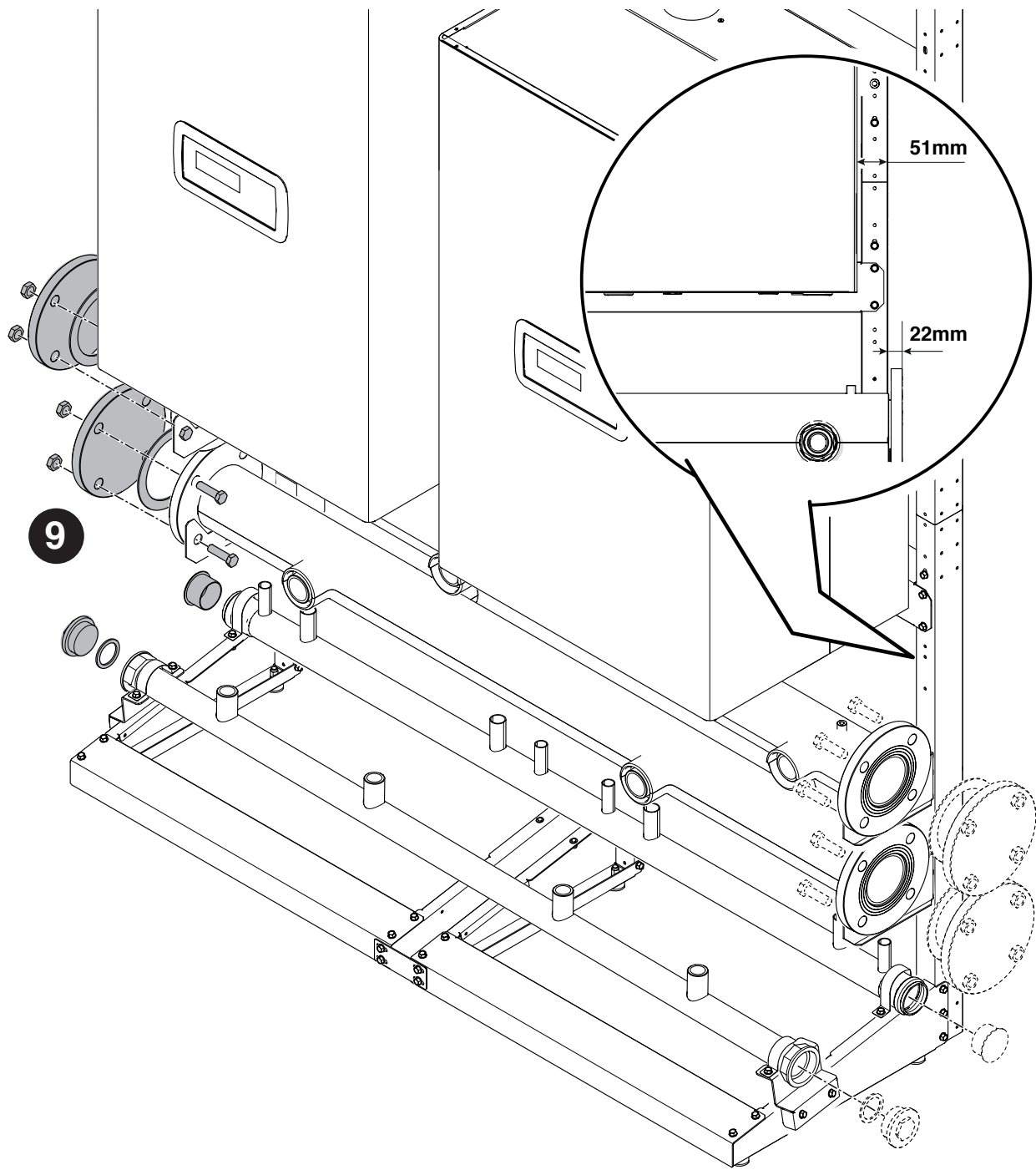

## 2.5 Positioning the 5" MANIFOLDS

### Assembly of the gas, delivery and return manifolds. Components included in code 20130222 - 20130223

The figure refers to an installation with 2 modules in line or 3/4 modules B2B.

- 1 Secure the left support bracket.
- 2 Secure the right support bracket.
- 3 Position the RETURN manifold.

 Make sure that the delivery and return manifolds are not inverted.

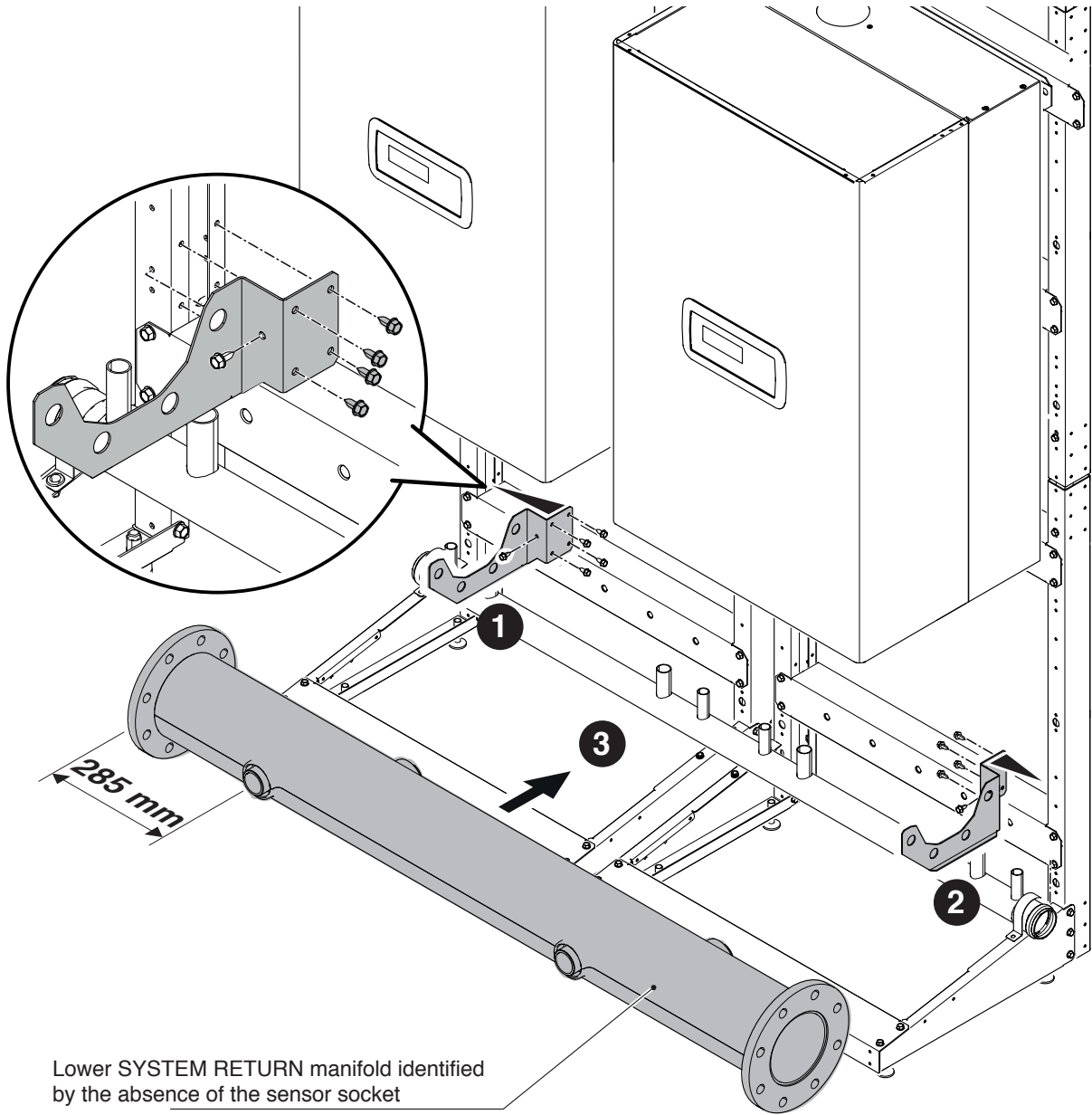

- 4 Secure the left support bracket.
- 5 Secure the right support bracket.
- 6 Position the DELIVERY manifold.

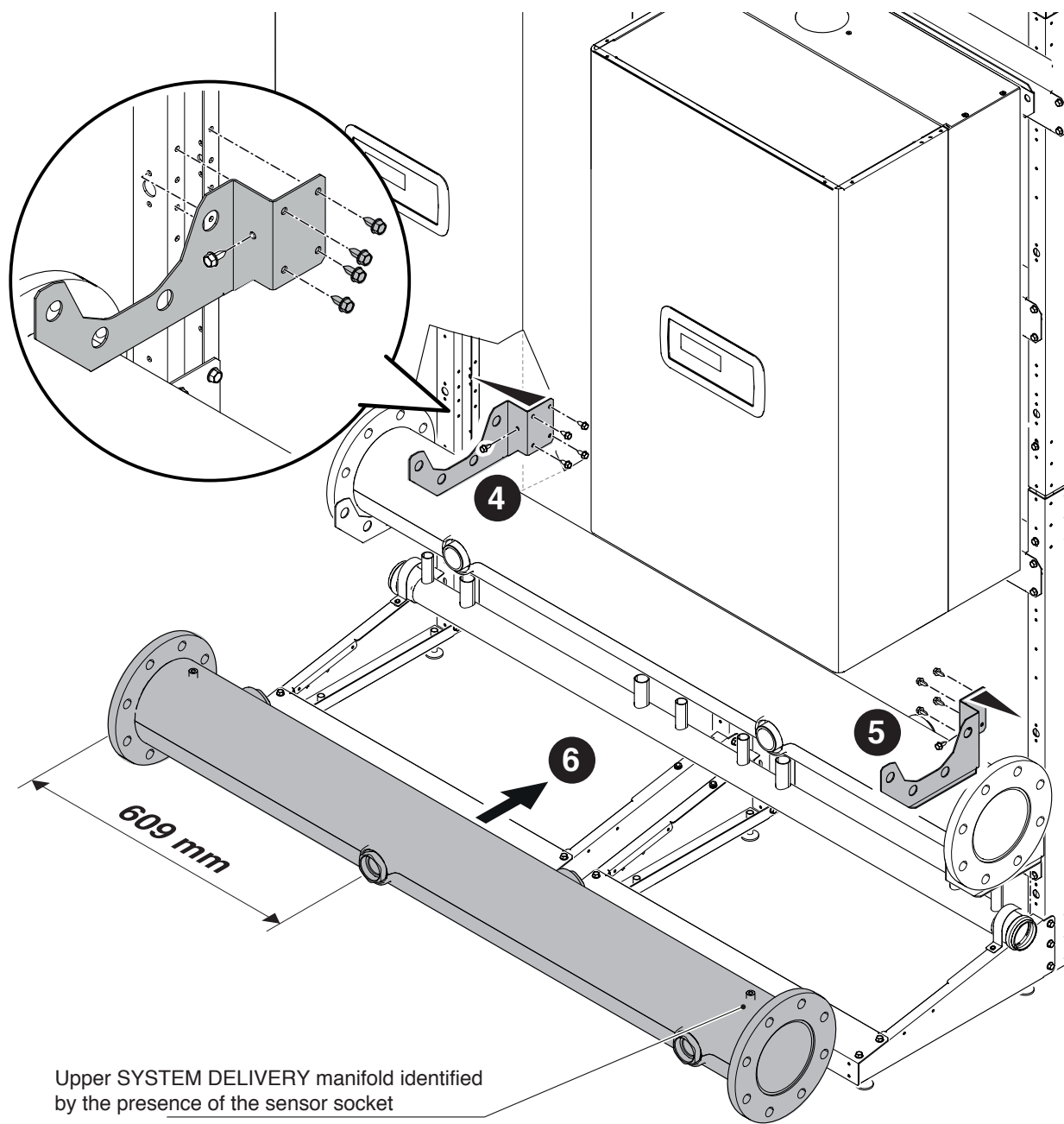

- 7 Position the GAS manifold.
- 8 Secure the GAS manifold to the frame.

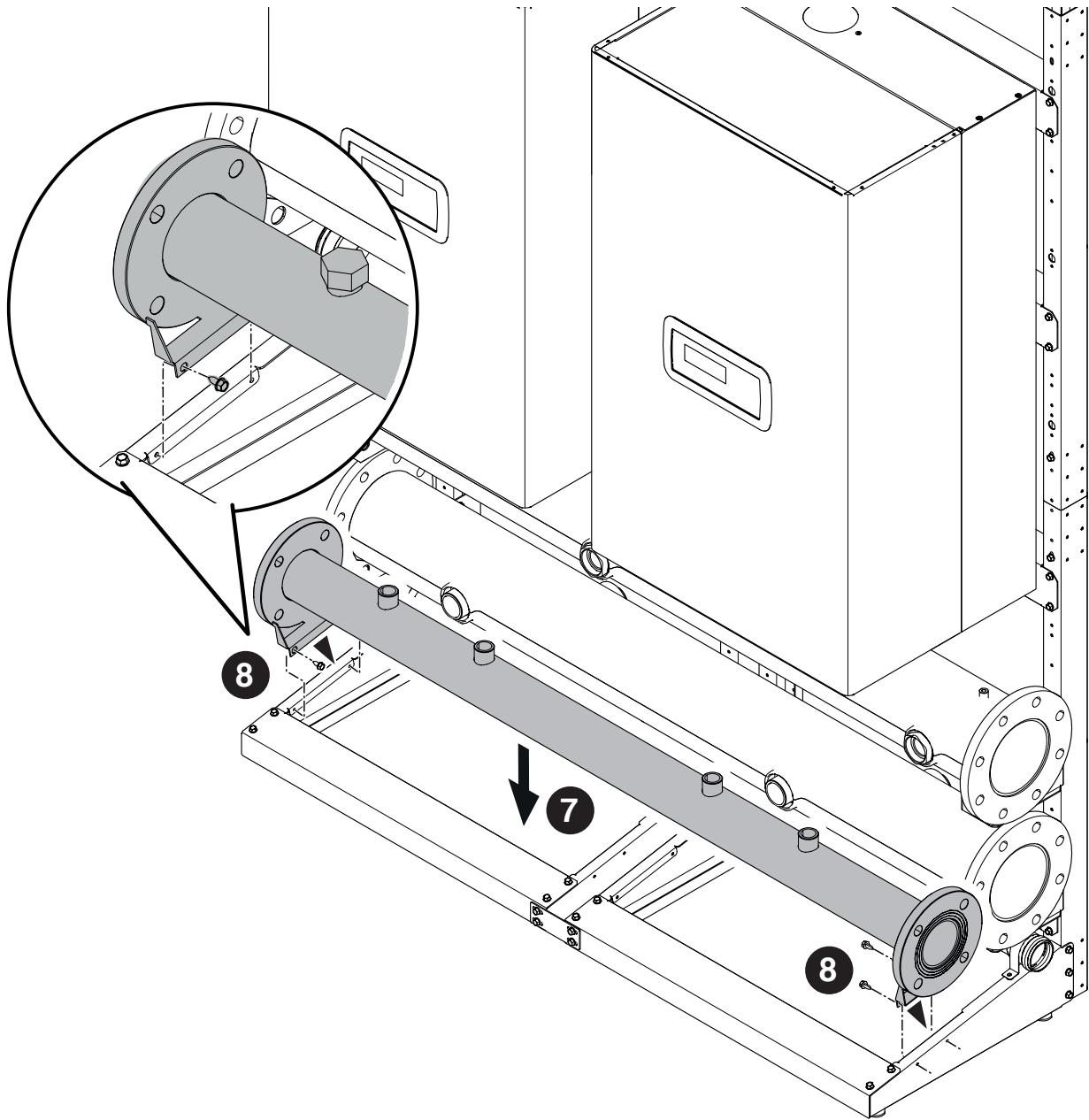

9 Position the manifold closing plugs from the required side.

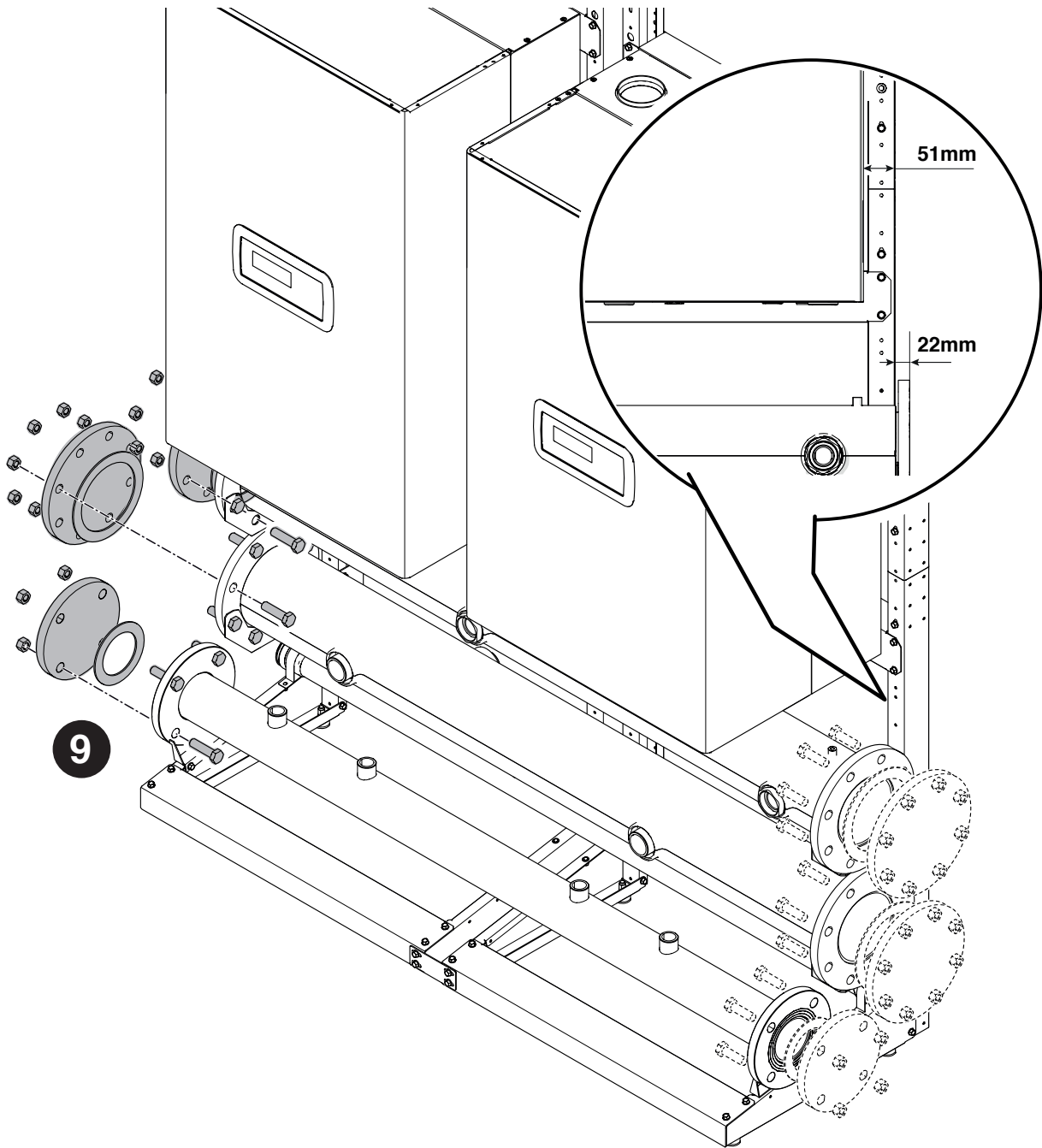





## 2.6 Positioning the CONDENSATE OUTLET

### Assembly of the condensate outlet. Components included in code 20131267

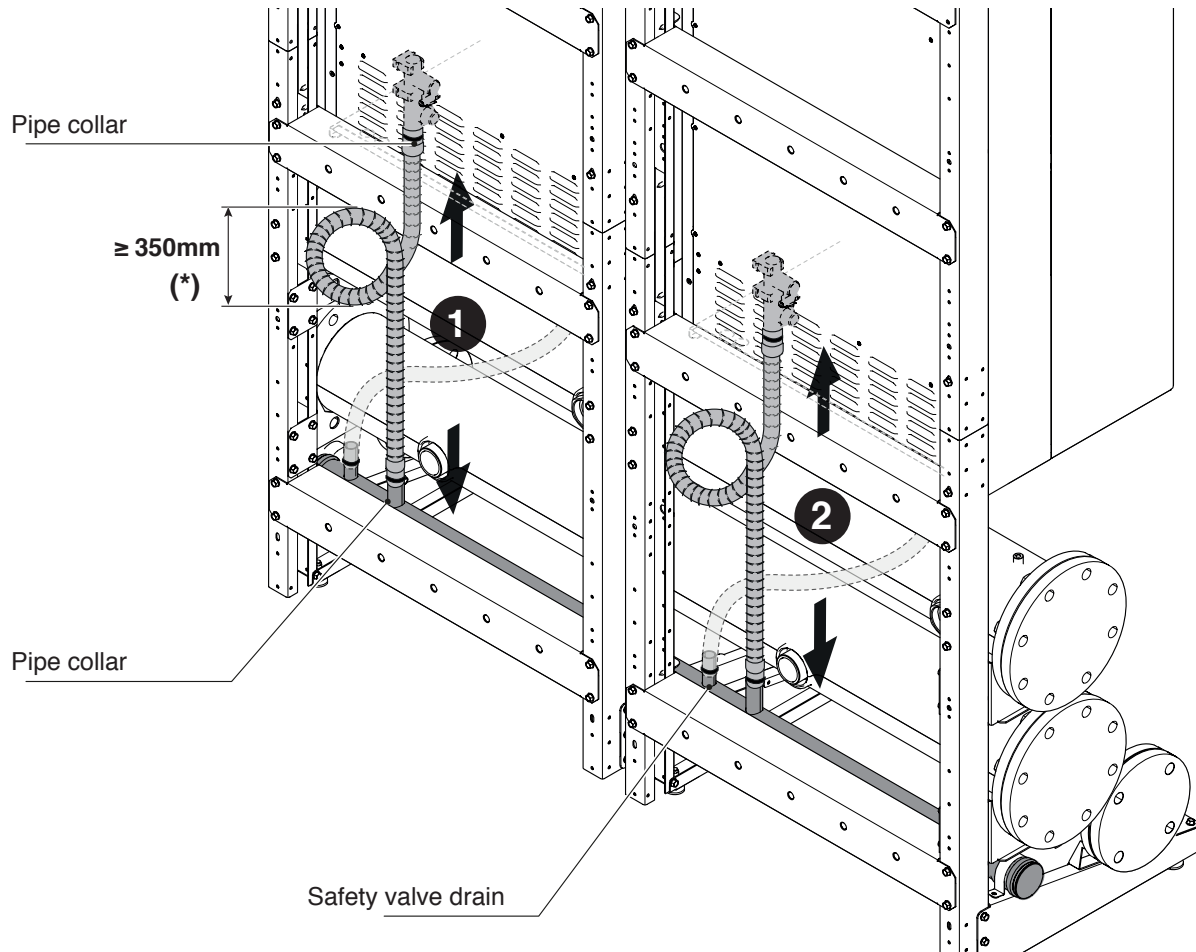
The figure refers to an installation with 2 modules in line or 3/4 modules B2B.

- 1 Make a siphon using the outlet pipe and secure it using cable ties (not supplied).
- 2 Connect the pipes to the other modules working in the same way as described for the first.



-  With modules in BACK TO BACK configuration, use the dedicated coupling points.
-  Correctly position the plugs on the coupling points which are not used.
-  The coupling points which are not used can be used for the relief valve outlet

## 2.7 Positioning the GAS PIPES

### CASCADE CONFIGURATION IN-LINE

Assembly of the gas pipes. Components included in code 20130658 – 20131121 – 20131122 – 20131123 – 20131124 – 20131125.

- 1 Install and seal the gas pipe to the module.
- 2 Install and seal the cock to the pipe and the gas manifold.
- 3 Fit the plugs onto any unused coupling points ensuring tightness.

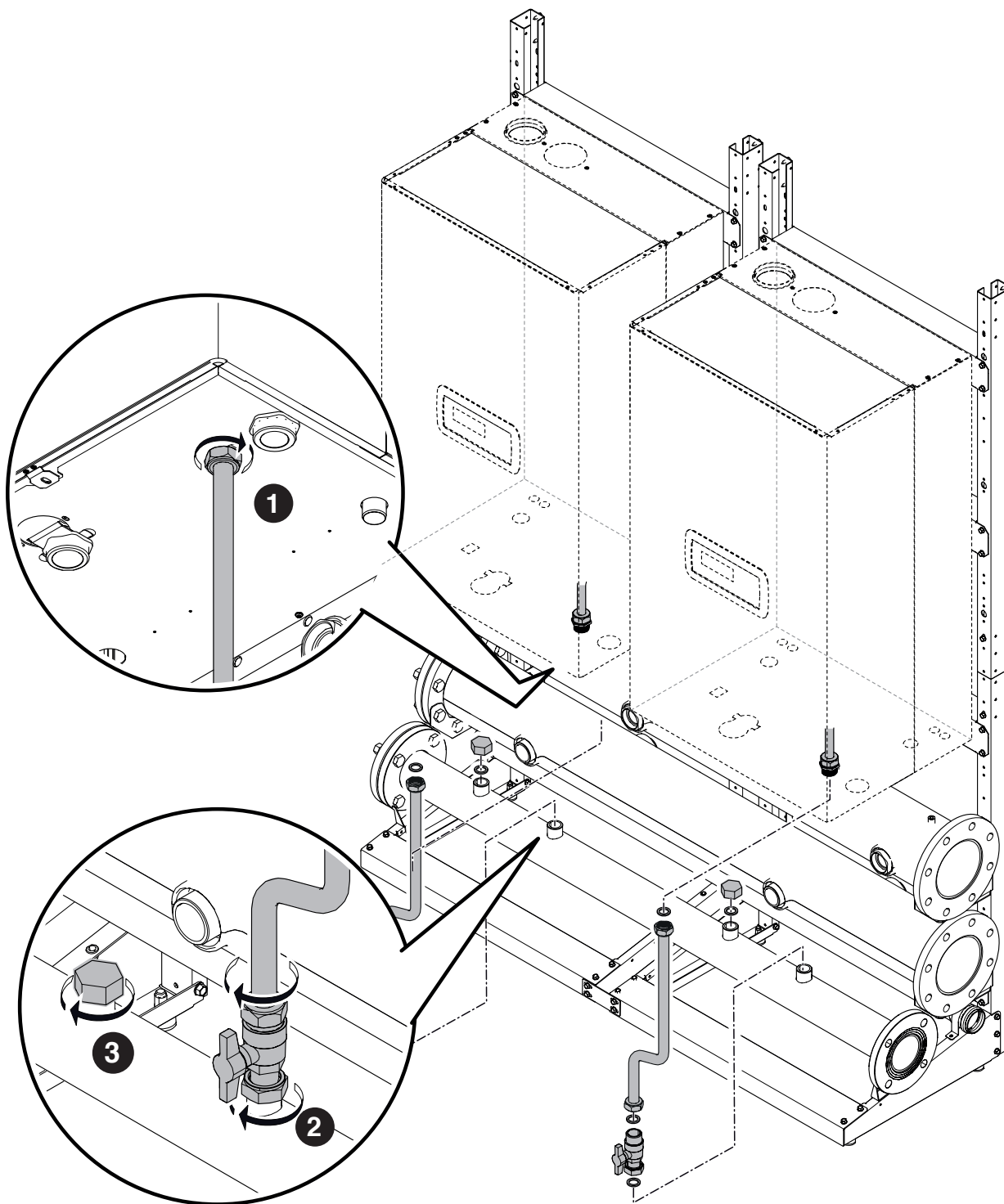

CASCADE CONFIGURATION B2B (BACK TO BACK)

Assembly of the gas pipes. Components included in code 20131787 – 20131788 – 20131789 – 20131790 – 20131791 – 20131792

- 1 Positioning the gas pipe.

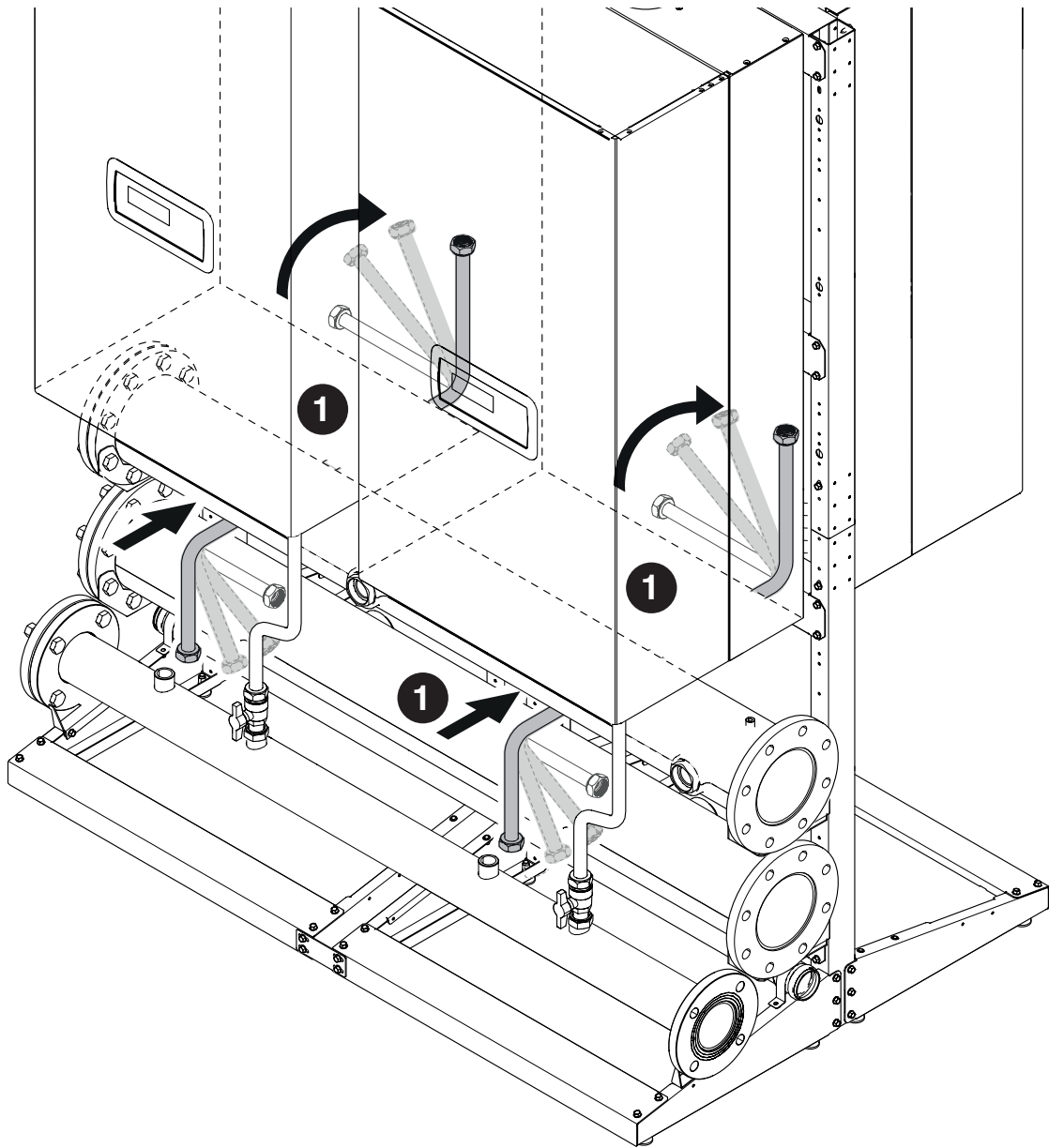

- 2 Installing and sealing the gas pipe to the module.
- 3 Install and seal the cock to the pipe and the gas manifold.

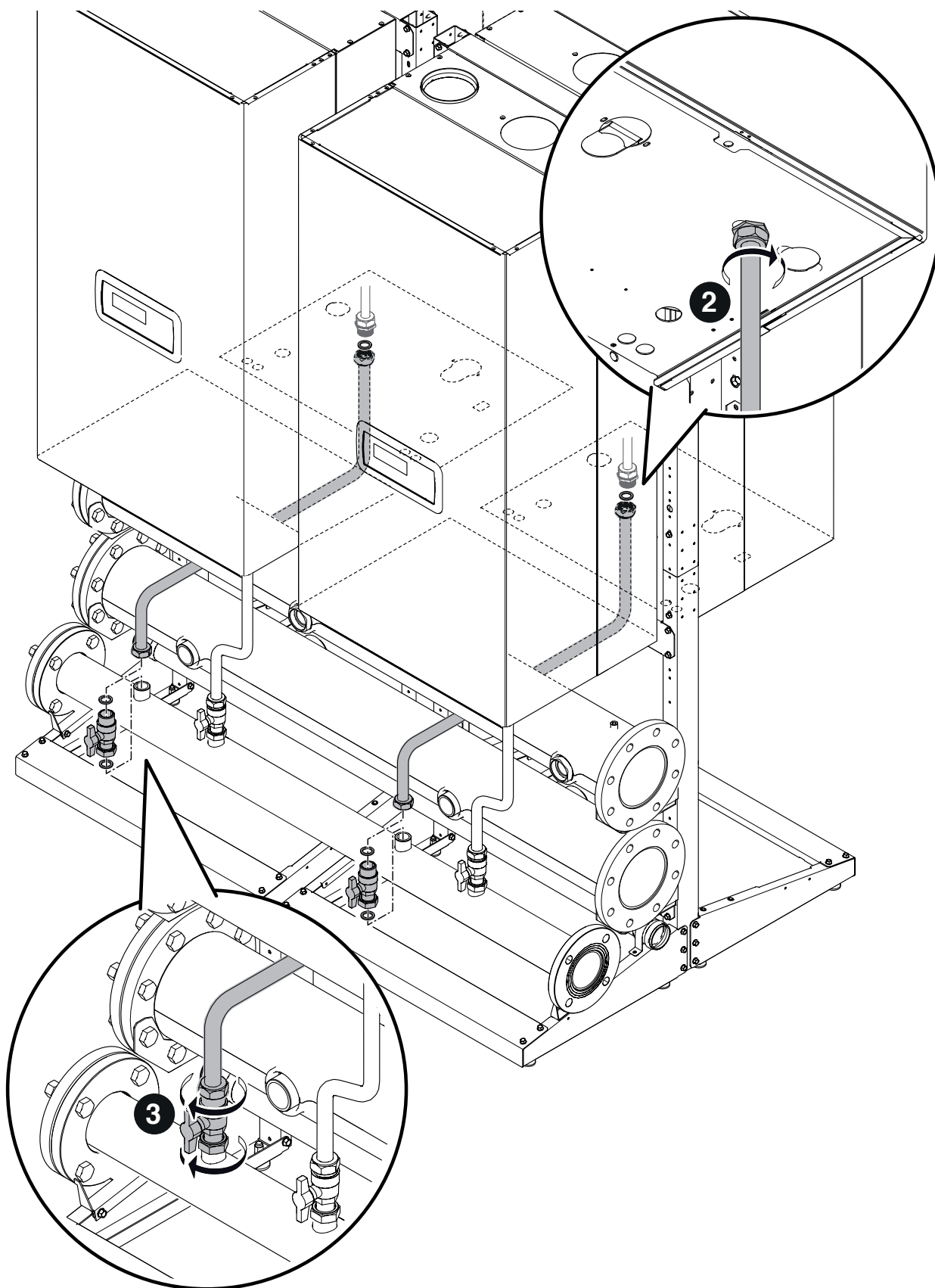

## 2.8 Positioning the DELIVERY-RETURN PIPES

### CASCADE CONFIGURATION IN-LINE

Assembly of the RETURN pipes. Components included in code 20130658 – 20131121 – 20131122 – 20131123 – 20131124 – 20131125

- 1 Install and seal the RETURN unit selected between the module coupling points (A) and (B) the return manifold.
- 2 Keep the insulation parts to one side and only fit them after testing has been completed.

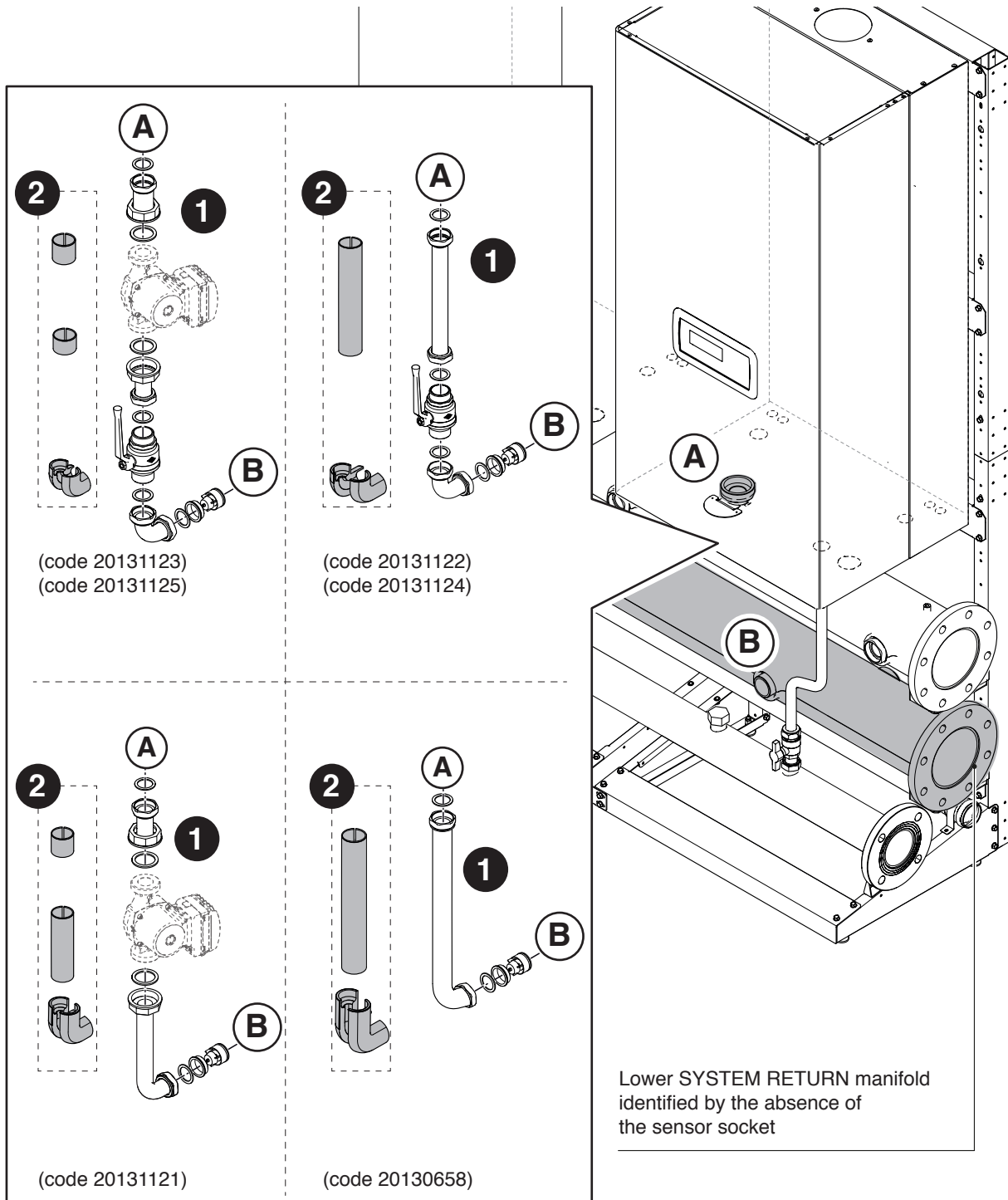

**A** Secure the plugs onto any unused coupling points.

CASCADE CONFIGURATION IN-LINE

Assembly of the DELIVERY pipes. Components included in code 20130658 – 20131121 – 20131122 – 20131123 – 20131124 – 20131125

- 3 Install and seal the DELIVERY unit selected between the module coupling points (C) and (D) the return manifold.
- 4 Keep the insulation parts to one side and only fit them after testing has been completed.

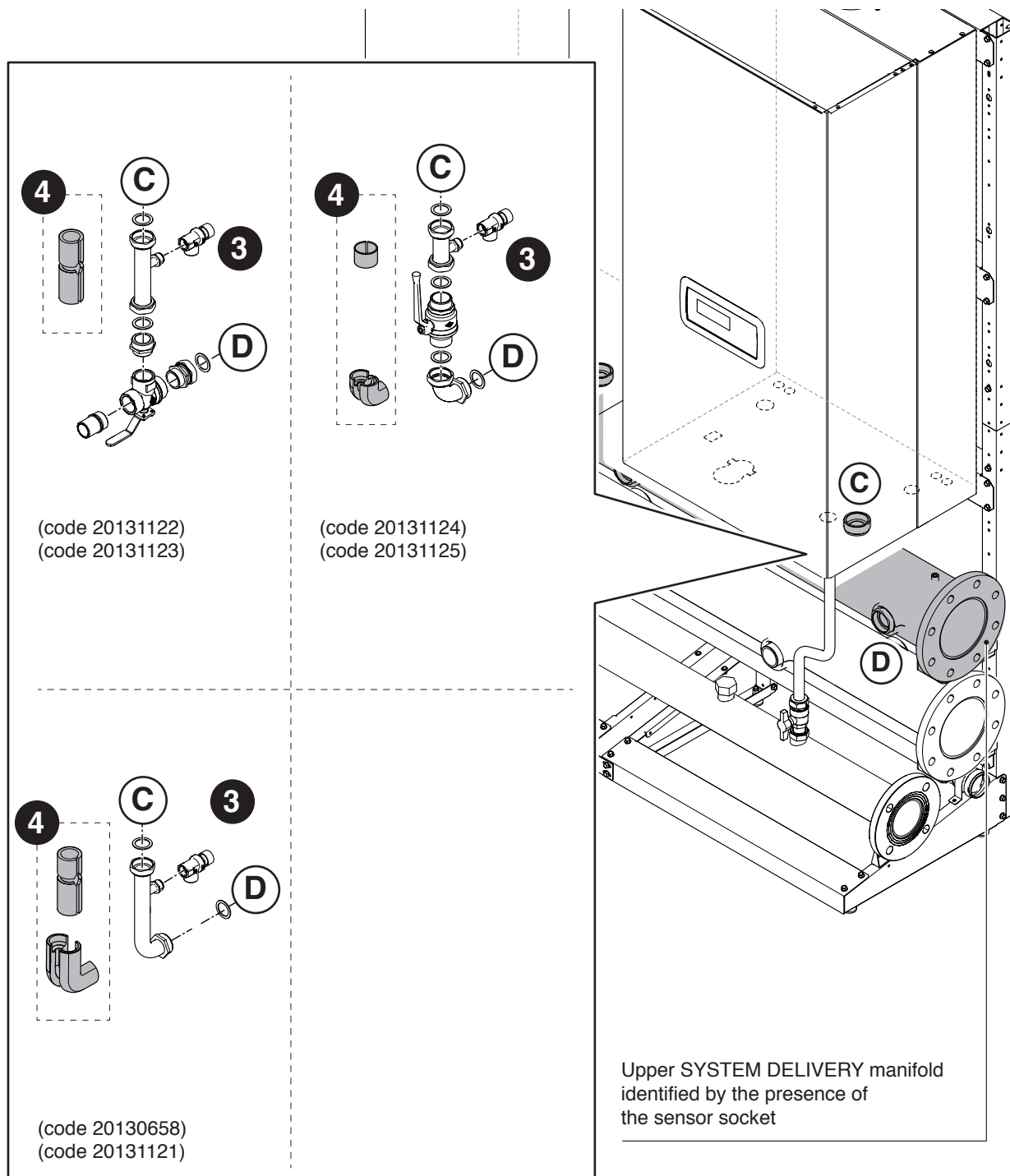

**A** Secure the plugs onto any unused coupling points.

CASCADE CONFIGURATION B2B (BACK TO BACK)

Assembly of the RETURN pipes. Components included in code 20131787 – 20131788 – 20131789 – 20131790 – 20131791 – 20131792

- 5 Install and seal the RETURN unit selected between the module coupling points (E) and (F) the return manifold.
- 6 Keep the insulation parts to one side and only fit them after testing has been completed.

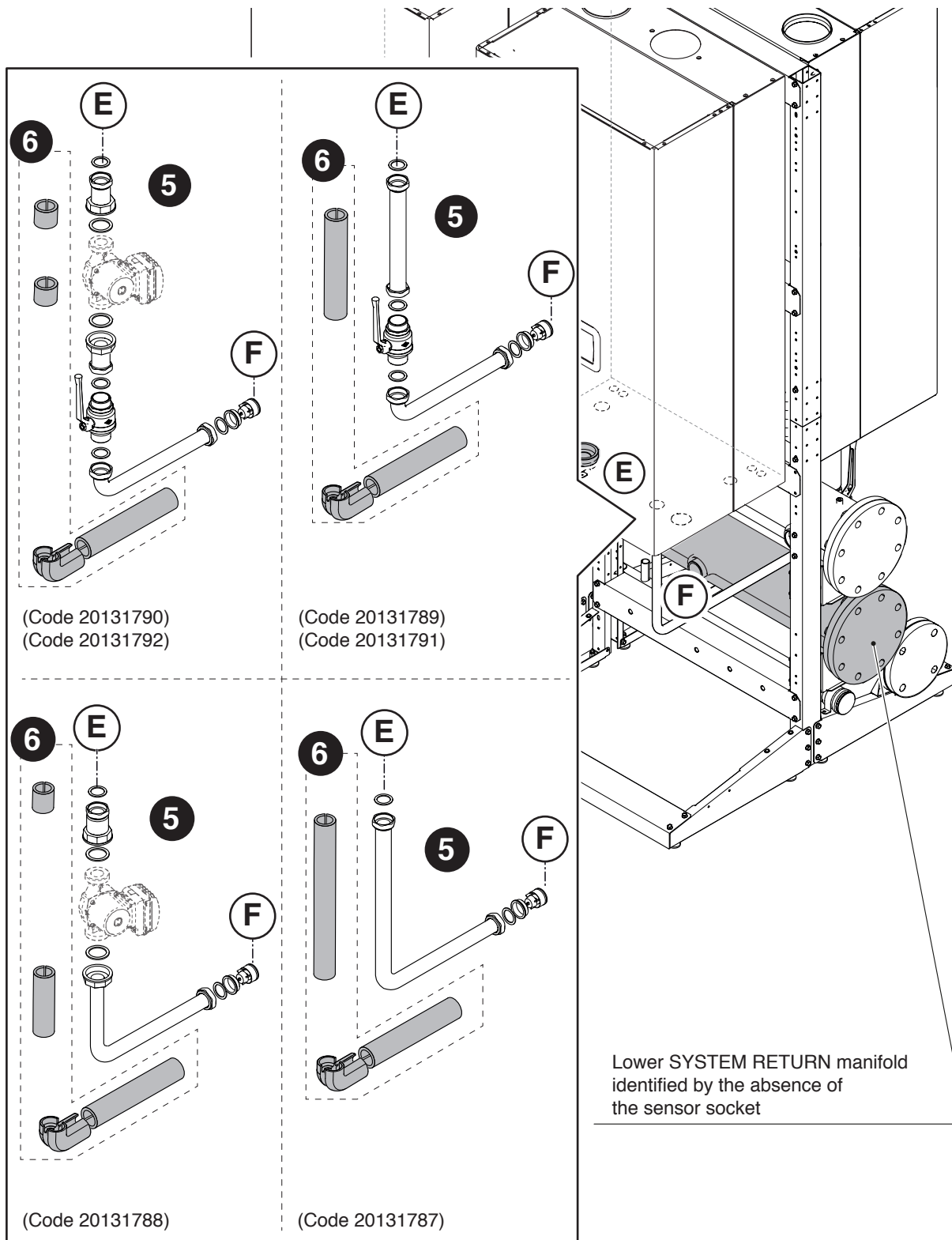

**A** Secure the plugs onto any unused coupling points.

**CASCADE CONFIGURATION B2B (BACK TO BACK)**

**Assembly of the DELIVERY pipes. Components included in code 20131787 – 20131788 – 20131789 – 20131790 – 20131791 – 20131792**

- 7 Install and seal the DELIVERY unit selected between the module coupling points (G) and (H) the return manifold.
- 8 Keep the insulation parts to one side and only fit them after testing has been completed.

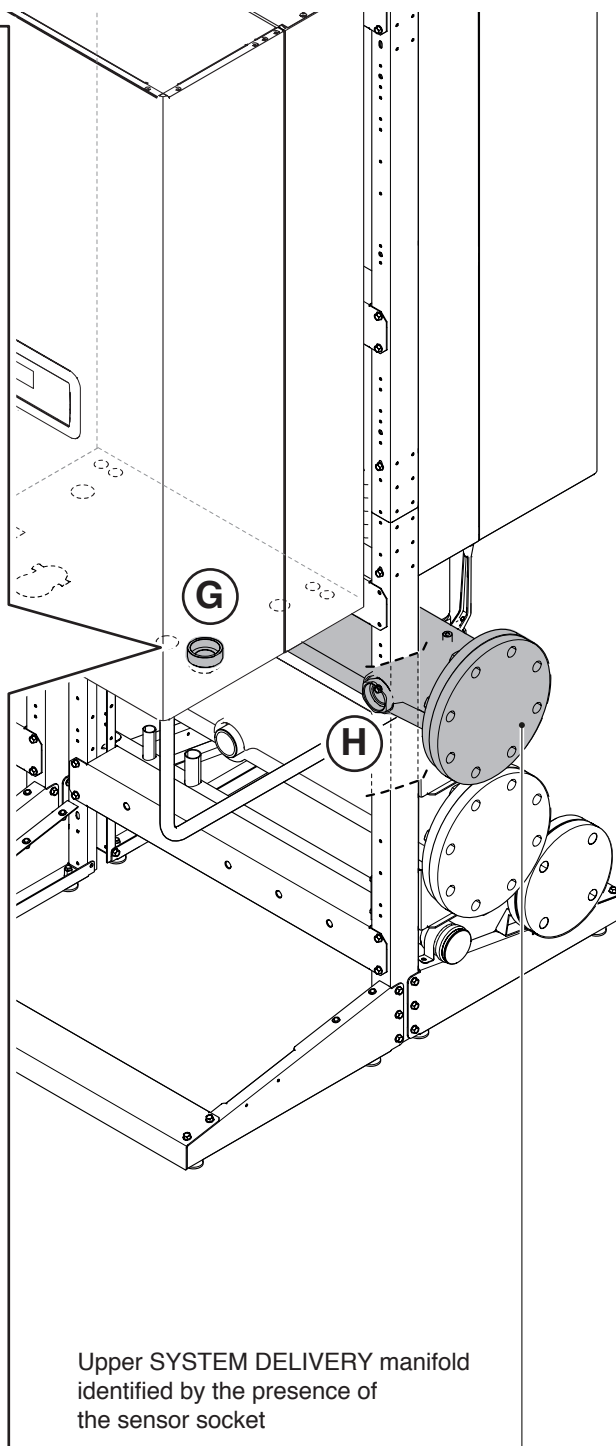
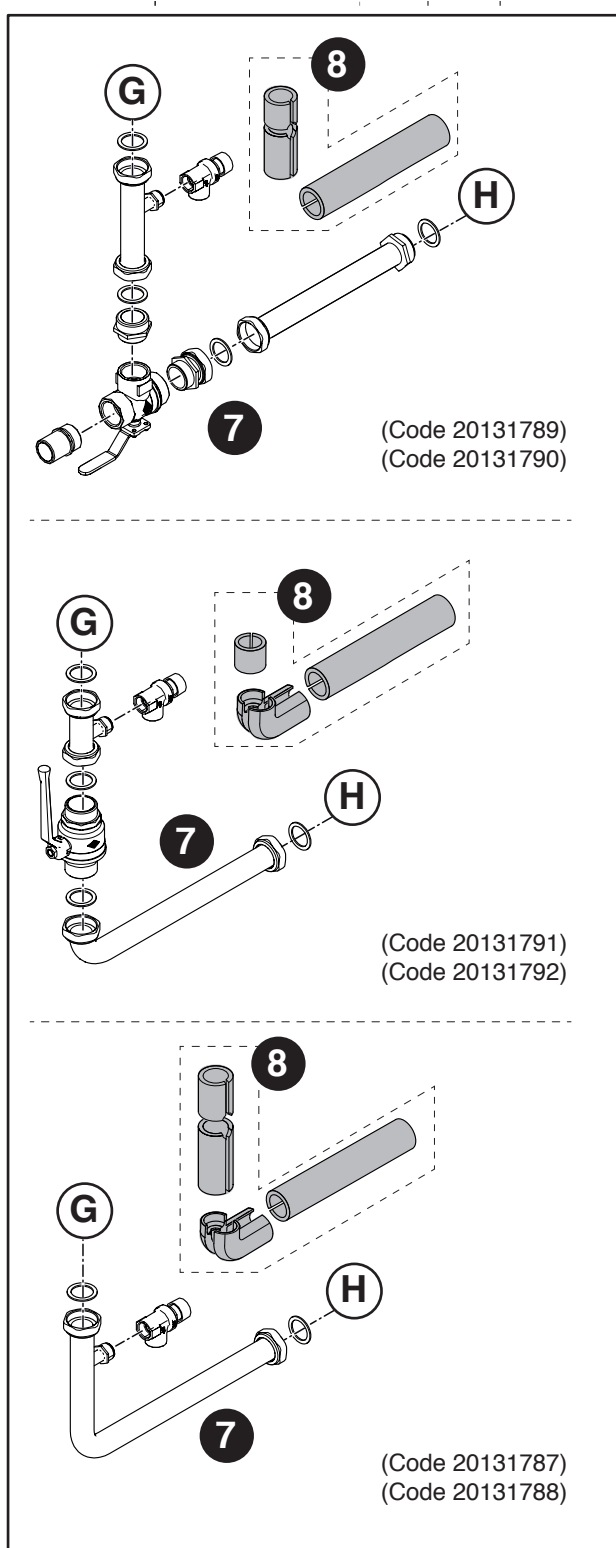

**A** Secure the plugs onto any unused coupling points.

## 2.9 Positioning the SAFETY SECTION AND SEPARATOR

**Assembly of the safety separator and separator. Components included in code 20070910 - 20070912 - 20132873 - 20070699 - 20070701 - 20070702 - 20132874 - 20070703 - 20070704 - 20070705 - 20071190 - 20023104 - 20023106 - 20009486 - 20009482 - 20009483 - 20061640**

- 1 Install and seal the selected return unit at the return manifold.
- 2 Install and seal the selected return unit at the separator. Installing the primary pump (if present).
- 3 Install and seal the selected INAIL section at the delivery manifold.
- 4 Install and seal the selected INAIL section at the separator.

Proceed to install the safety elements contained in the specific kit.

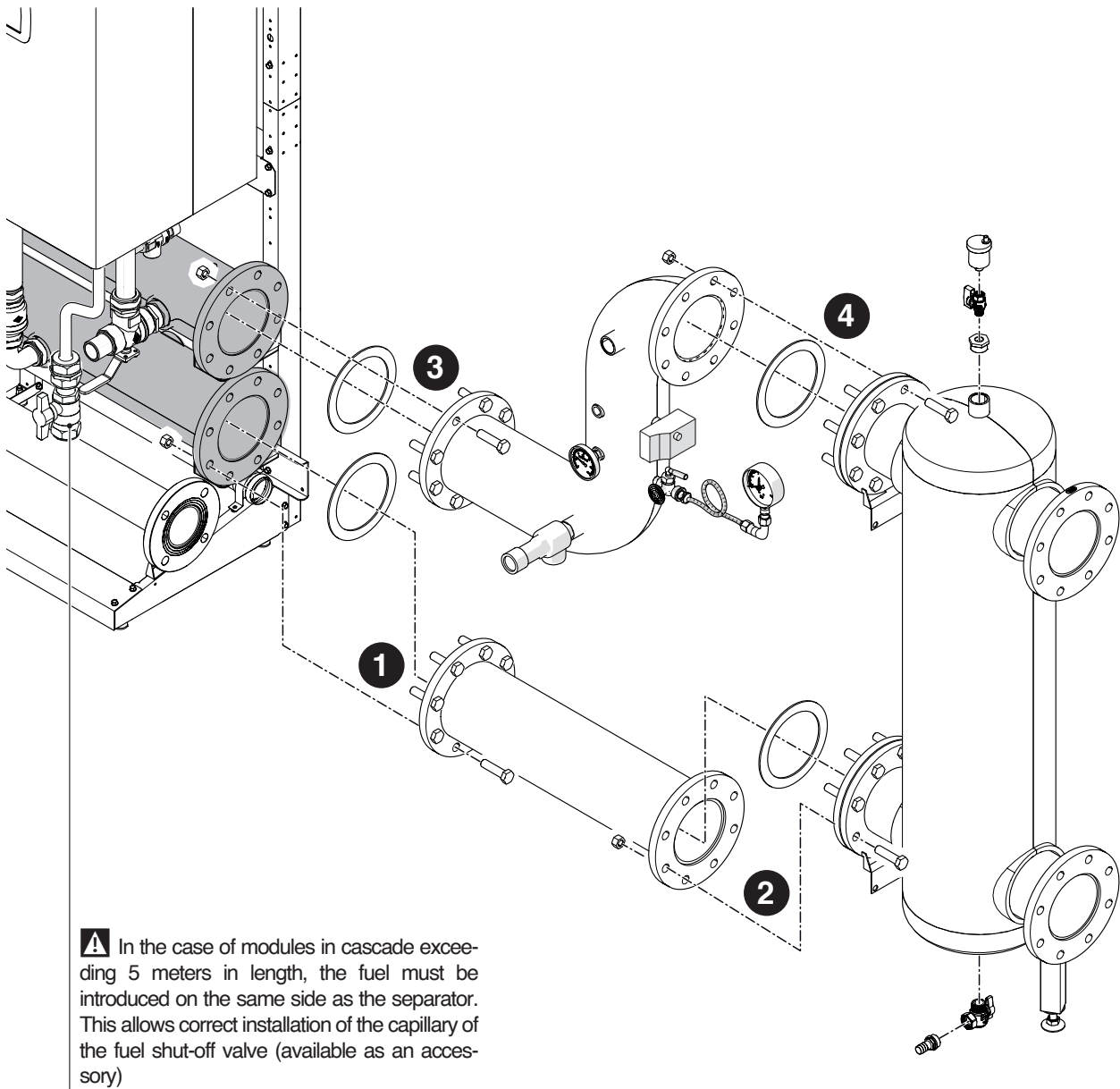

Once all the hydraulic connections have been made, the tightness test of the system can be carried out and the insulation parts can be fitted to complete the system.

**⚠** Follow the safety and system filling procedures as indicated in the user manual of the individual appliances **Condexa PRO**.

CASCADE CONFIGURATION IN-LINE

Assembly of the FLUE SYSTEM DN 160 - DN 200 - DN 250. Components included in code 20131266 - cod. 20132381 - cod. 20131218

1 Carefully cut the bends following the measurements indicated. This allows the flue gas outlet duct to slope by at least 3°

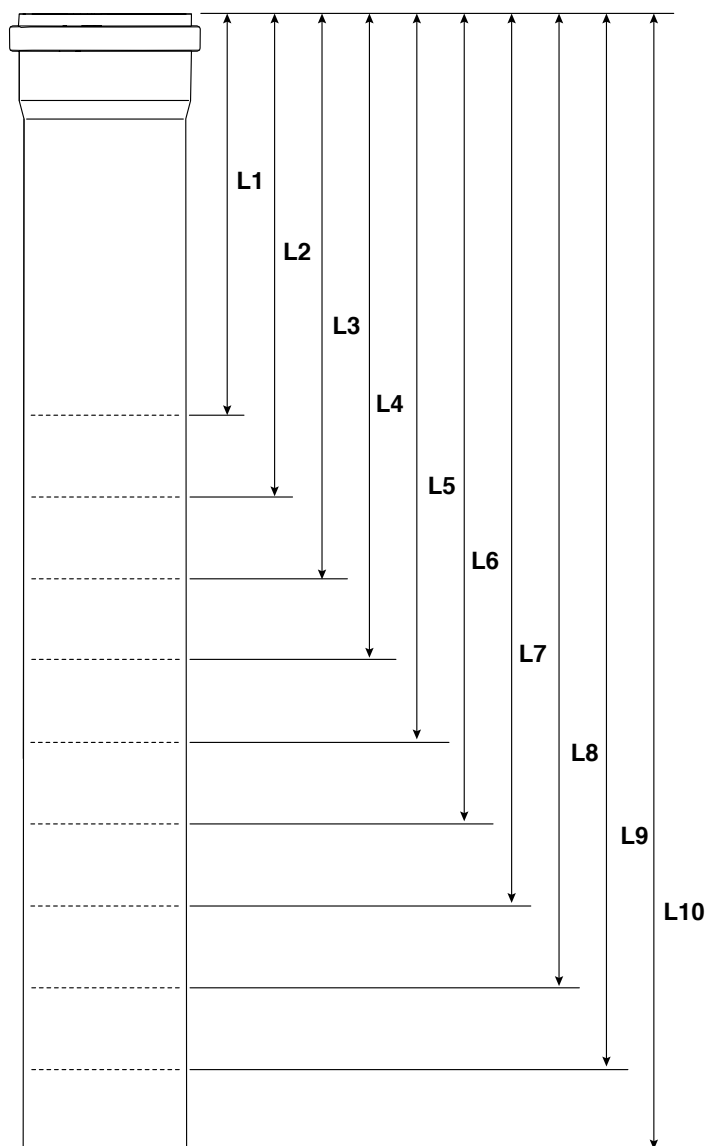
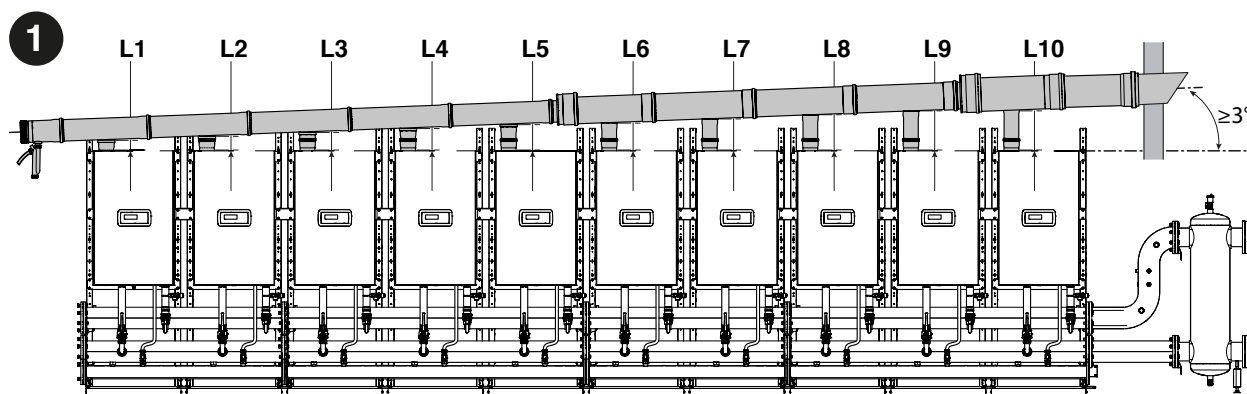

L1	L2	L3	L4	L5	
142	172	202	232	262	mm

L6	L7	L8	L9	L10	
292	322	352	382	412	mm

**⚠** A DN80/DN110 adapter is required ONLY FOR Condexa PRO 57 P and Condexa PRO 70 P MODELS with flue gas outlet DN80. This adapter is to be installed on the flue outlet and subsequently the cutting lengths must be reduced by 60mm.

**⚠** ONLY FOR Condexa PRO 135 MODELS, no more than 8 modules.

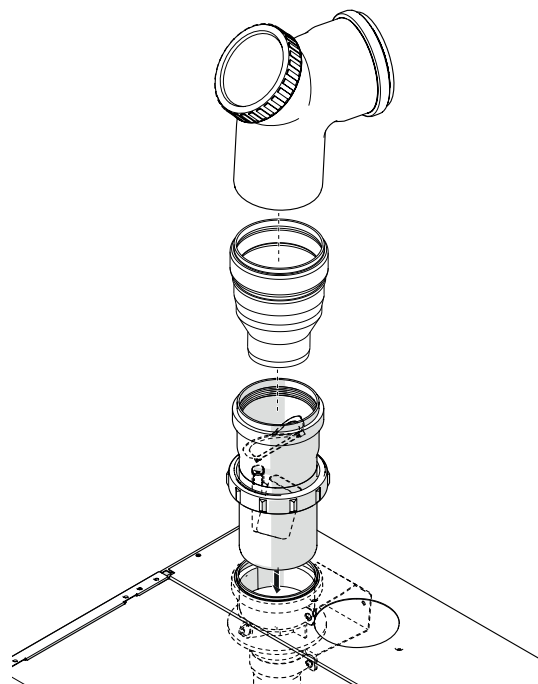

- 2 Pre-assemble the flue gas outlet duct on the ground. Moisten the seals with non-corrosive lubricant (water-based additive with polymers and silicone oil) and make sure that they can be adjusted during the final positioning operations.

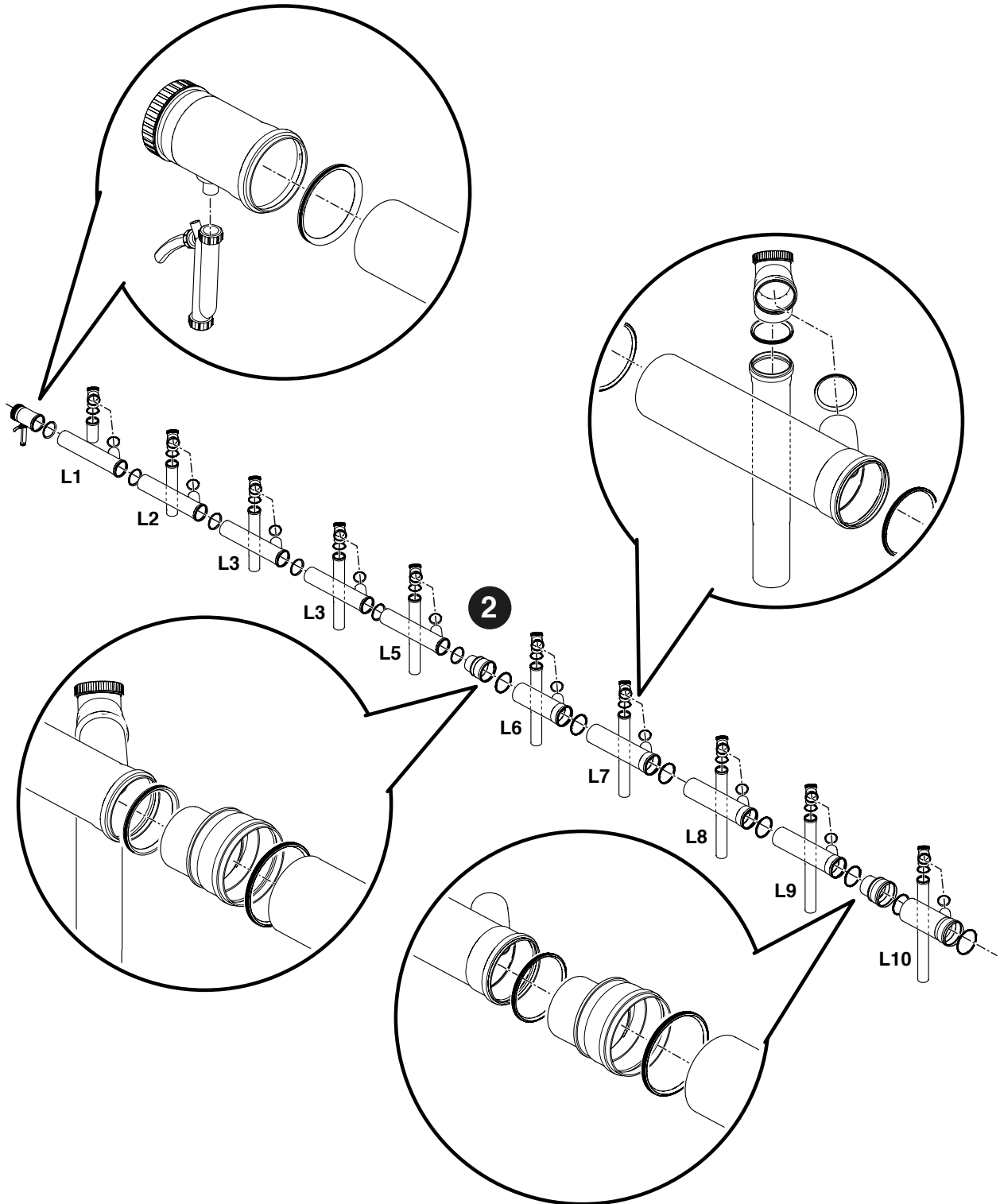

- 3 Position the flue gas outlet manifold above the modules. Check that a slope of at least  $3^\circ$  towards the condensate outlet siphon is guaranteed.
- 4 Connect the siphon outlet to the condensate drainage system.

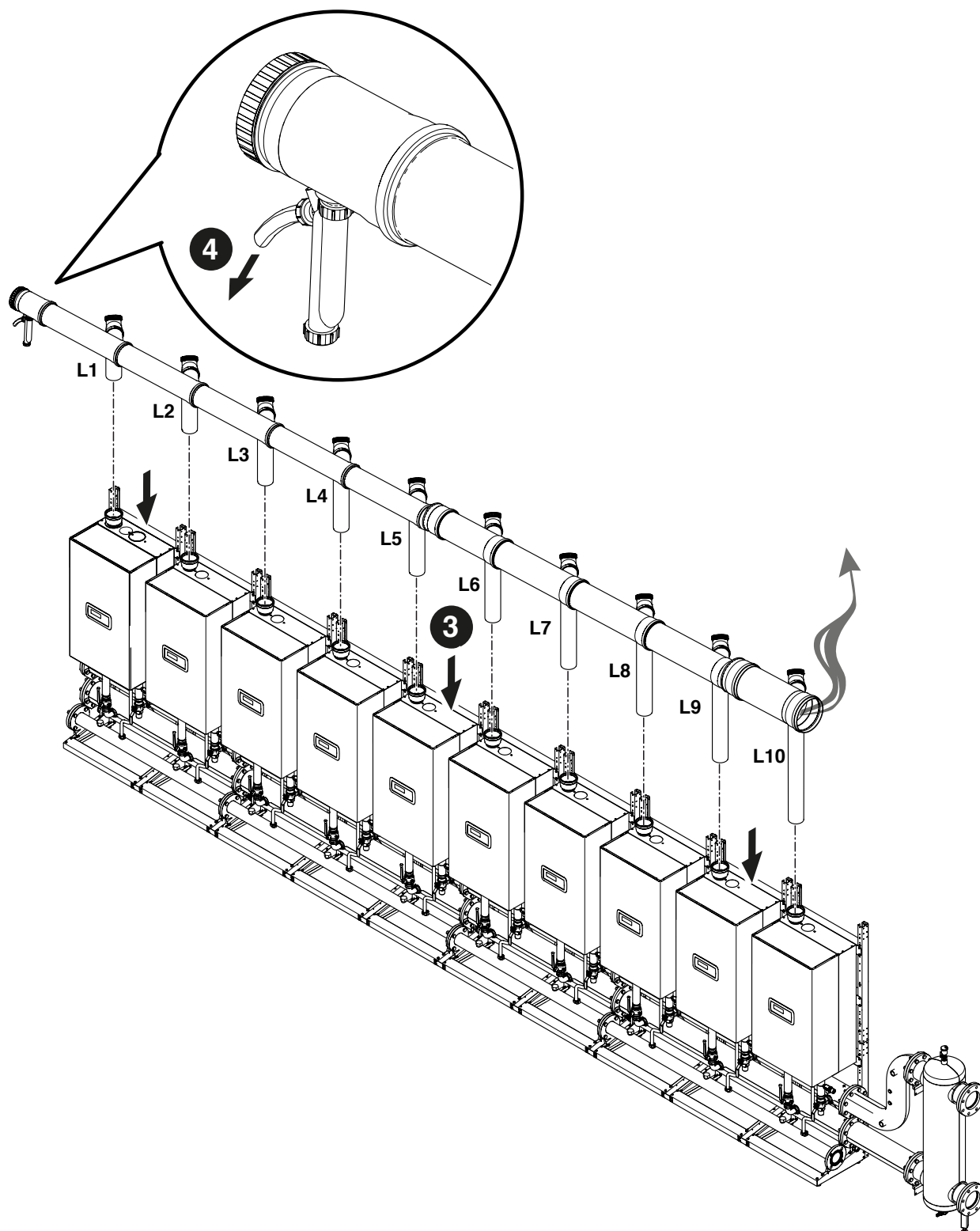

CASCADE CONFIGURATION B2B (BACK TO BACK)

Assembly of the FLUE SYSTEM DN 160 - DN 200 - DN 250. Components included in code 20131266 - cod. 20132381 - cod. 20131218

1 Carefully cut the bends following the measurements indicated. This allows the flue gas outlet duct to slope by at least 3°

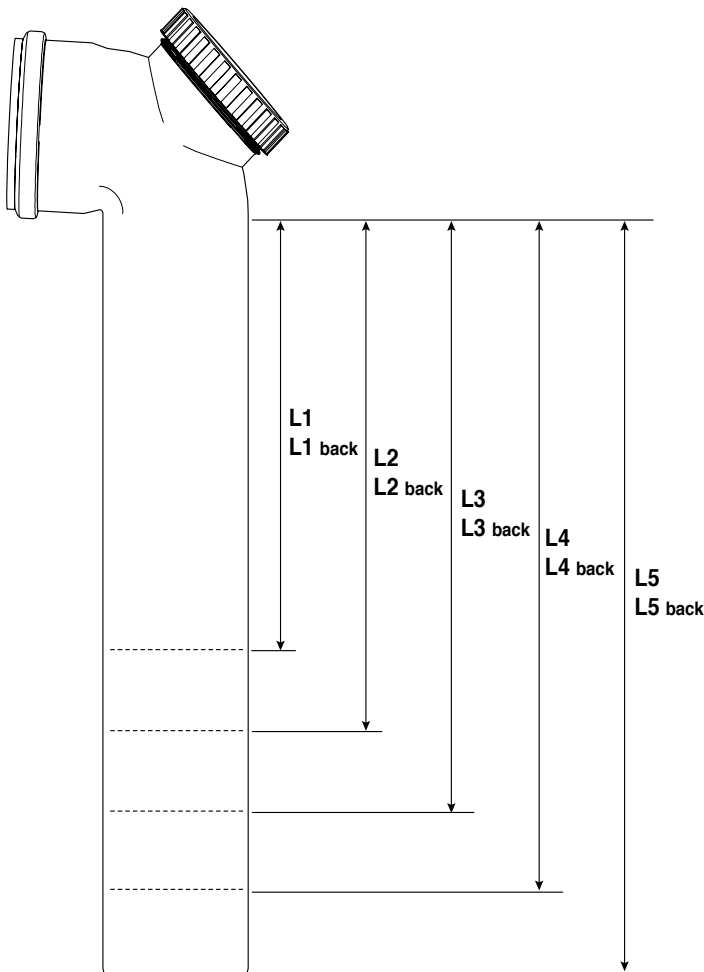
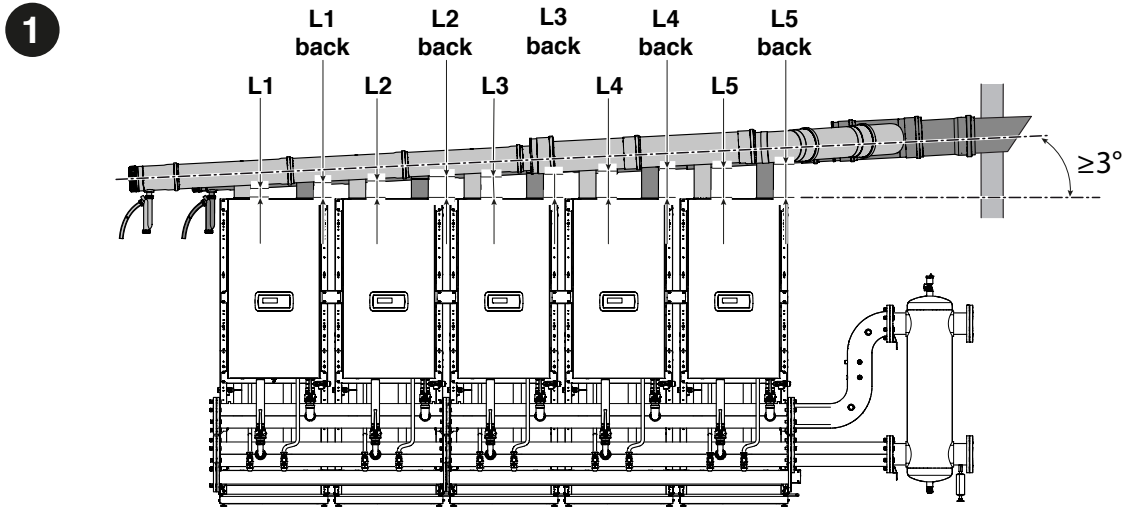

**⚠** A DN80/DN110 adapter is required ONLY FOR Con-dexa PRO 57 P MODELS with flue gas outlet DN80. This adapter is to be installed on the flue outlet and subsequently the cutting lengths must be reduced by 60mm.

**⚠** ONLY FOR Con-dexa PRO 135 MODELS, no more than 8 modules.

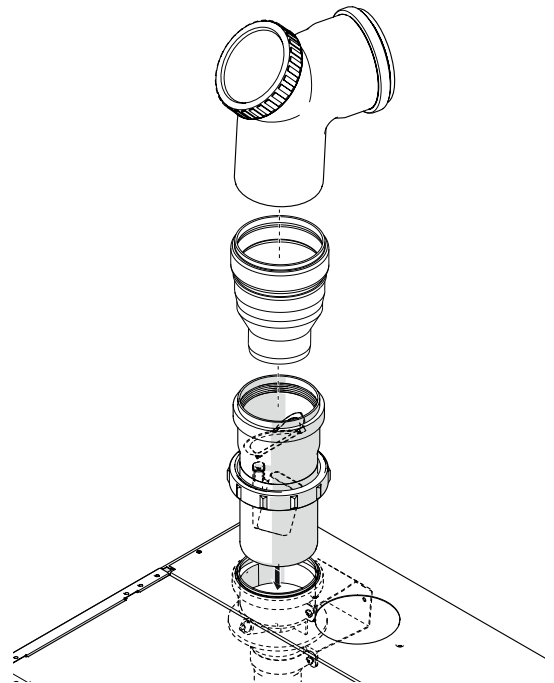

L1 L1 back	L2 L2 back	L3 L3 back	L4 L4 back	L5 L5 back	
172	197	236	275	315	mm

- Pre-assemble the flue gas outlet duct on the ground. Moisten the seals with non-corrosive lubricant (water-based additive with polymers and silicone oil) and make sure that they can be adjusted during the final positioning operations.

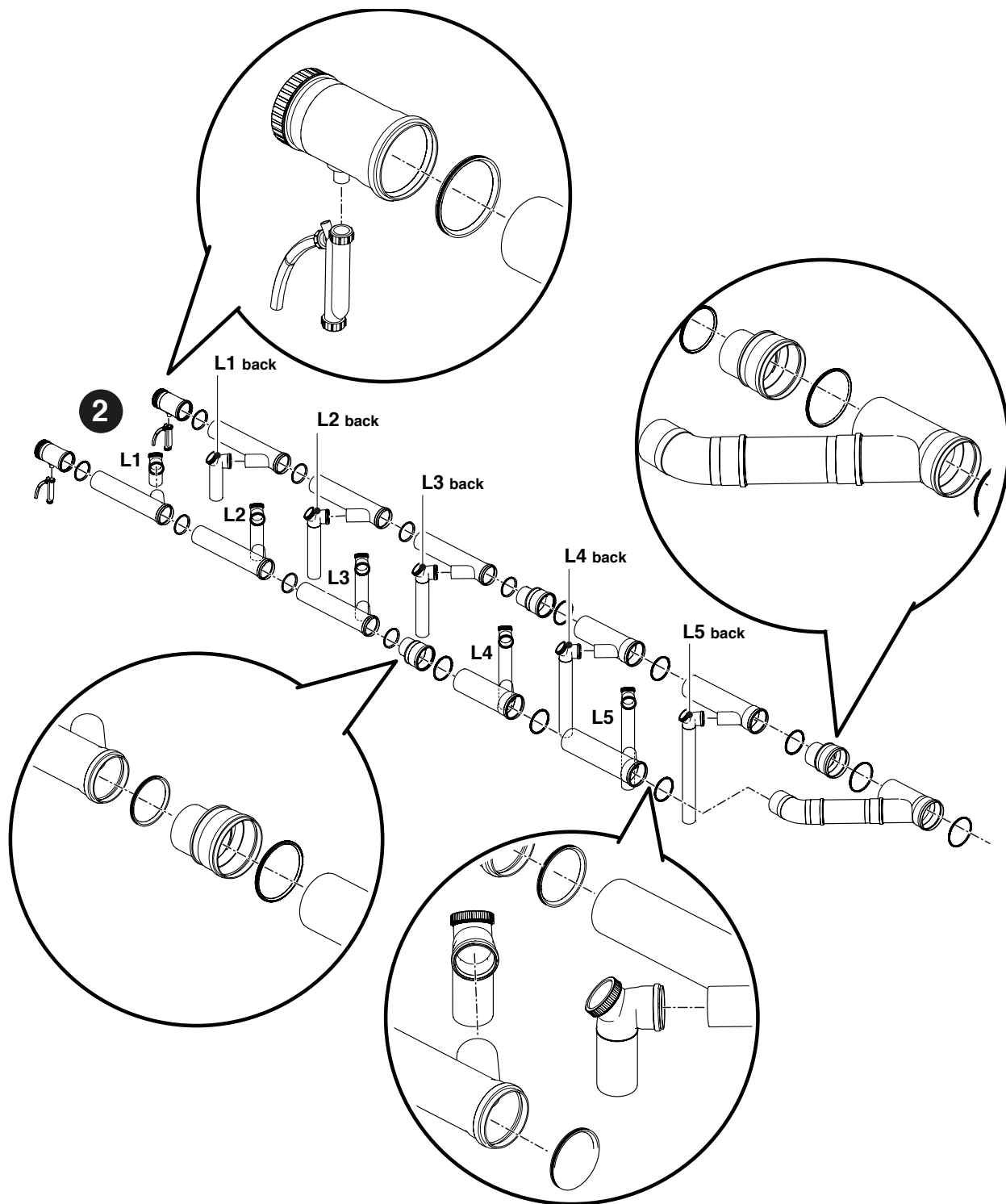

- 3 Position the flue gas outlet manifold above the modules. Check that a slope of at least 3° towards the condensate outlet siphon is guaranteed.
- 4 Connect the siphon outlet to the condensate drainage system.

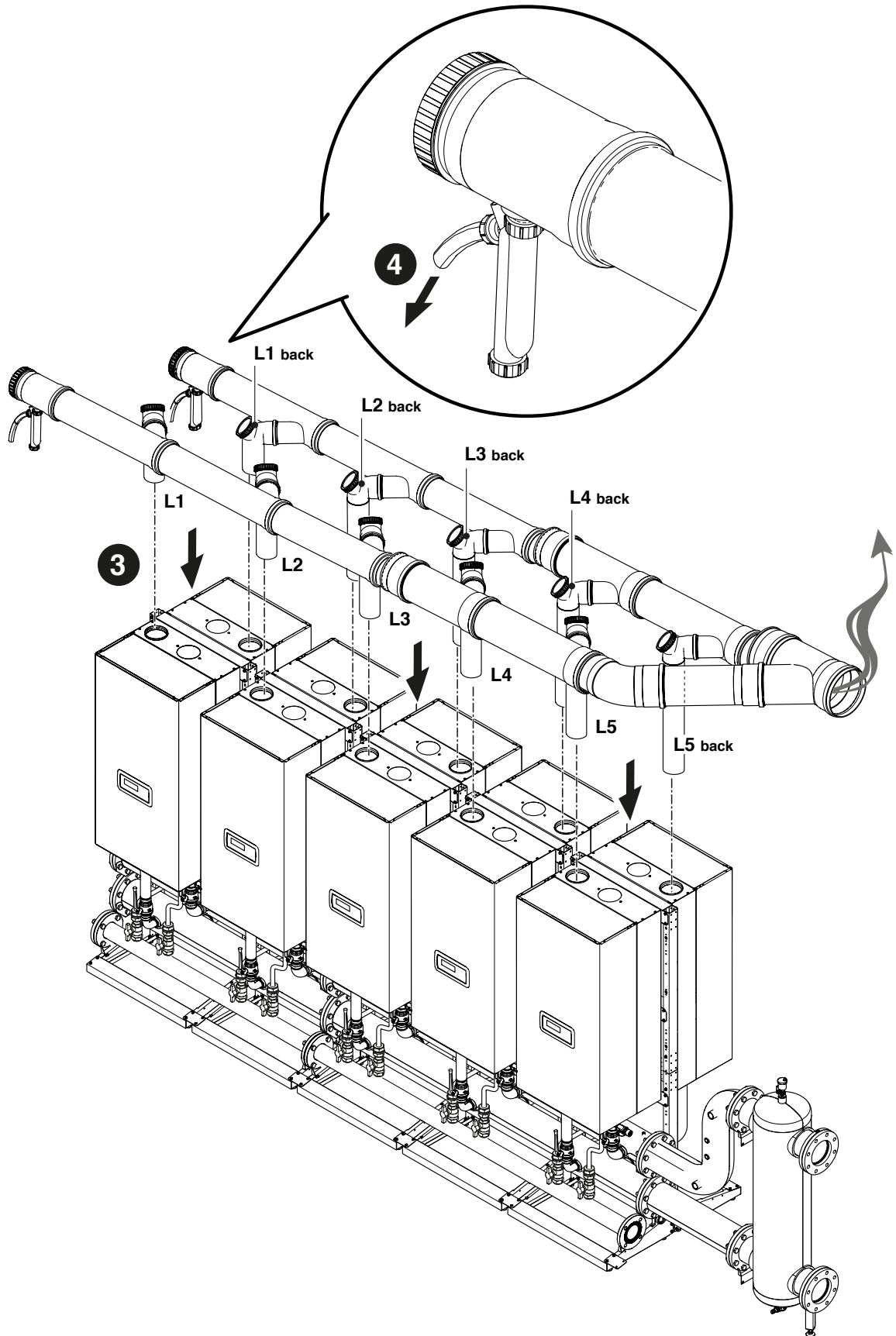

5 Complete the flue gas outlet pipe sizing it appropriately and taking into consideration the data in the table indicated below.

	Number of modules	DN flue gas manifold	Maximum length expressed in meters
Condexa PRO 57 P	2	160	30
	3	160	30
	4	160	30
	5	160	30
	6	160	30
	7	200	30
	8	200	30
	9	200	30
Condexa PRO 70 P	10	200	30
	2	160	30
	3	160	30
	4	160	30
	5	160	30
	6	160	30
	7	200	30
	8	200	30
Condexa PRO 100	9	200	30
	10	200	30
	2	160	30
	3	160	30
	4	160	30
	5	200	30
	6	200	30
	7	200	30
Condexa PRO 115	8	250	30
	9	250	30
	10	250	30
	2	160	30
	3	160	30
	4	160	30
	5	200	30
	6	200	30
Condexa PRO 135	7	250	30
	8	250	30

## 2.10 Neutralization of the condensate

To correctly eliminate the combustion condensate, check if the condensate needs to be neutralized using a designated accessory.

- For systems with a nominal heat input greater than 200 kW, the condensate always needs to be neutralized
- For systems with a nominal heat input greater than 57 kW but less than 200 kW, the selection and evaluation criteria is provided in the figure below

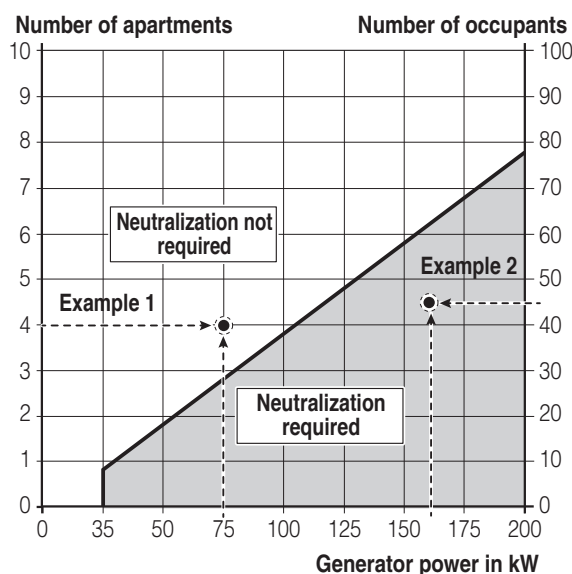

### Example 1

For a residential building with 4 apartments, a 75 kW condensing boiler needs to be installed. The 4 apartments / 75 kW intersection point is within the range "neutralization not required", therefore the condensate does not need to be neutralized.

### Example 2

For an office block with 45 users, a 160 kW condensing boiler needs to be installed. The 45 users / 160 kW intersection point is within the range "neutralization required", therefore the condensate needs to be neutralized.

In the case of residential applications, reference must be made to the number of apartments served by the system, while in the case of non-residential applications, reference must be made to the number of users.

In the case of mixed applications, the number of apartments must be converted into equivalent users, or conversely, according to the alignment of the two vertical axes, therefore refer only to one axis (for example, 2 apartments equate to 20 users).

**⚠** The condensate drainage system must be sized and installed to ensure correct elimination of the effluents produced by the appliance and/or by the evacuation system of the combustion products in any and all operating conditions.

### 3 CONFIGURATION OF THE MAIN BLOCK DIAGRAMS

- ⚠** The DHW and heating circuits must be completed with expansion vessels of a suitable capacity and correctly sized relief valves. The discharge of the relief valves and the appliances must be connected to an evacuation and collection system (see paragraph Neutralization of the condensate).
- ⚠** The installer is responsible for selecting and installing the system components and must work in full compliance with correct technical regulations and legislation in force.
- ⚠** Special supply/refill water must be conditioned using suitable treatment systems.
- ⚠** For the electrical connections, use H05-W-F power cables with a minimum cross-section of 1.5 mm<sup>2</sup>, complete with terminal ferrules. For the low voltage connections, use H05-W-F power cables with a minimum cross-section of between 0.5 and 1 mm<sup>2</sup>, complete with terminal ferrules.
- ⚠** For the connection of the devices connected to the jig (pumps, circulators and diverting / mixing valves) use interposed relays unless the maximum absorption of all components connected to the board (including the module circulator) is less than or equal to 1.5 A. Relays sizing lays on the installer Dependent on the type of connected device.
- ⊖** It is prohibited to operate the module and the pumps without water.

#### 3.1 Configuration of the primary system

The basic cascade configuration consists of at least two modules. One is assigned "Managing" role and the others are assigned the "Dependent" role. The cascade of modules can be seen as the primary system of a generation system. This configuration could be ideal for replacing one or more larger generators in an existing system if system reliability and efficiency is to be increased.

In order for cascade operation to be possible, the "Managing" module must be connected to the primary sensor (SS) at least, available as an accessory. The primary sensor is required in order to manage the cascade setpoint and is essential for managing the modules as a single generator.

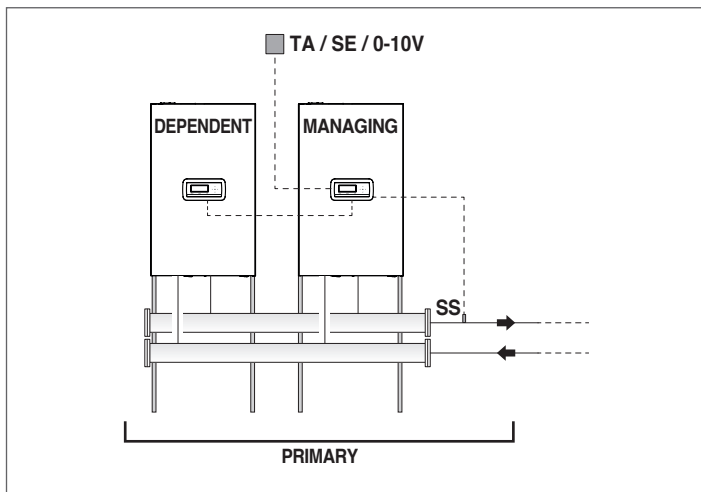

Operation of the primary system can be:

- Mode 0 - With fixed setpoint. This configuration requires the connection of an ambient thermostat or heat request contact (TA).
- Mode 1 - In climatic mode with variable setpoint based on the outdoor temperature. This configuration requires the connection of an ambient thermostat or heat request contact (TA) and an external sensor (SE), available as an accessory.
- Mode 2 - In climatic mode with intensity controlled by the ambient thermostat/heat request signal and variable setpoint based on the outdoor temperature. This configuration requires the connection of an ambient thermostat or heat request contact (TA) and an external sensor (SE), available as an accessory.
- Mode 3 - With fixed setpoint with intensity controlled by the ambient thermostat/heat request signal. This configuration requires the connection of an ambient thermostat or heat request contact (TA).
- Mode 4 - With delivery setpoint adjustment on the basis of the analogue input 0-10V. This configuration requires an external device (for example, PLC of the central heating plant) able to generate this signal connected to the analogue input 0-10 V.

The functions described can be set using the parameterization carried out on the "Managing" module. This is described in the manual of the individual modules in the paragraph "Setting the heating system".

The electrical and hydraulic connections of the primary system are to be completed selecting from:

- Use of the module pump (as standard in Condexa PRO 57 P - Condexa PRO 70 P and available as an accessory for Condexa PRO 90 - Condexa PRO 135 models).
- Use of the system pump (PS) and two-way valve (V1) for each module (these devices are available as accessories).

### 3.2 Configuration of the secondary system

Optimal use of the modules in cascade occurs by placing a hydraulic separator (available as an accessory) between the primary system (modules in cascade for thermal generation) and the secondary system (users, such as heat distribution systems, DHW production). This device allows a different flow rate to be compensated between the primary and secondary systems.

For the sake of simplicity, the hydraulic circuits downstream of the separator can be identified as the secondary system. The basic configuration of the secondary system takes place using a system circulator (PI). This circulator, connected to the modules in cascade, allows the transfer of the heat energy to a user circuit to be controlled, for example, a direct zone for high temperature heating of a room.

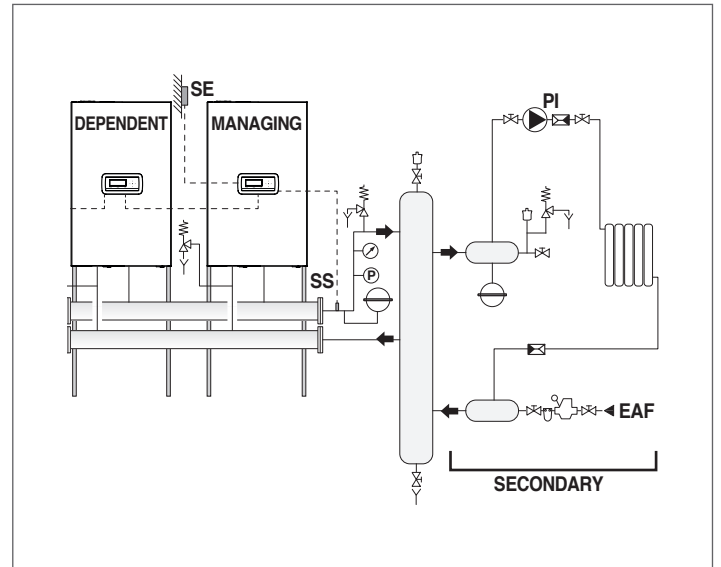
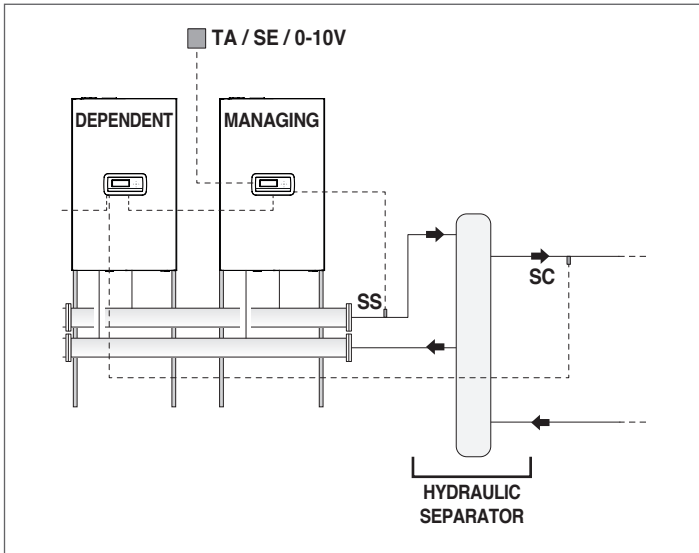

The secondary system can be configured using the following accessories:

- Secondary sensor (SC) or cascade  
This is required in order to manage the setpoint, and therefore the required temperature, downstream of the hydraulic separator.  
The secondary sensor is connected to the controller of the first "Dependent" module.
- Hot water tank sensor (SB)  
This is required in order to manage the production of DHW in combination with a hot water tank circulator (PB).  
The hot water tank sensor is connected to the controller of the "Managing" module.

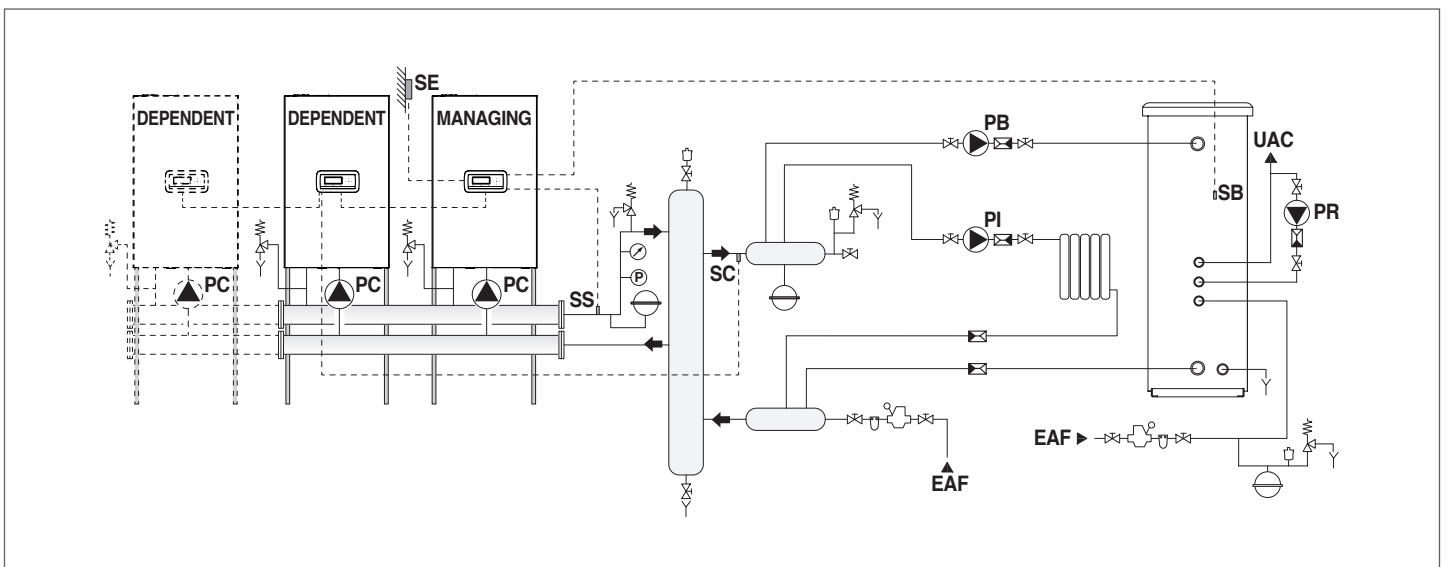



### 3.3 Block diagram 1: Cascade of modules with primary sensor (SS)

Recommended system diagram for new systems or where the water flow rate in the secondary circuit is equal to that in the primary circuit with modules with their own circulator, connected in cascade.

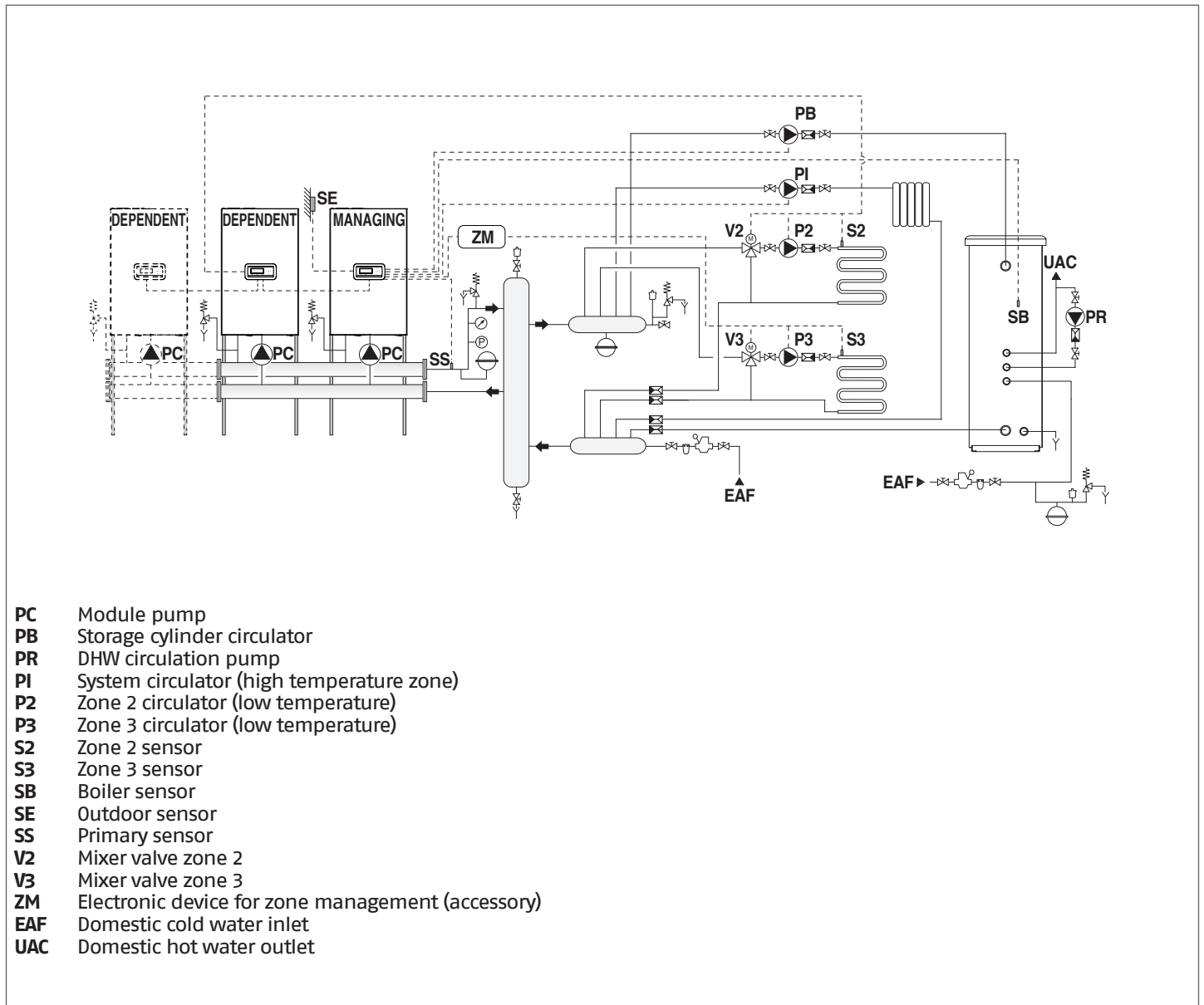

To address the modules and connect the BUS, see Chapter System management.

The modulation of each module depends on the delivery temperature of each unit.

If the SC (secondary) does not reach the setpoint temperature "within a certain time", the setpoint temperature of the primary is raised.

SS (primary) manages solely the switching on and off of the individual modules.

### 3.3.1 Electrical power connections

#### MANAGING CONNECTIONS

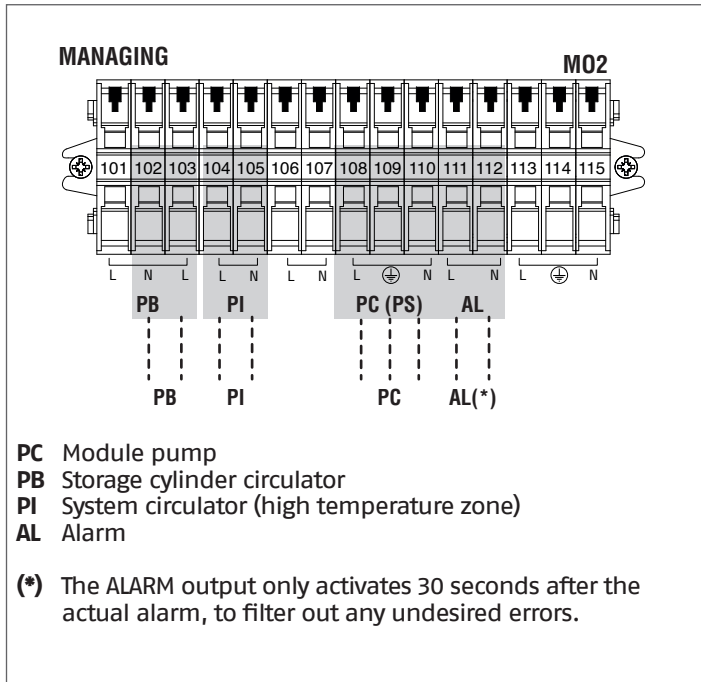

#### DEPENDENT CONNECTIONS

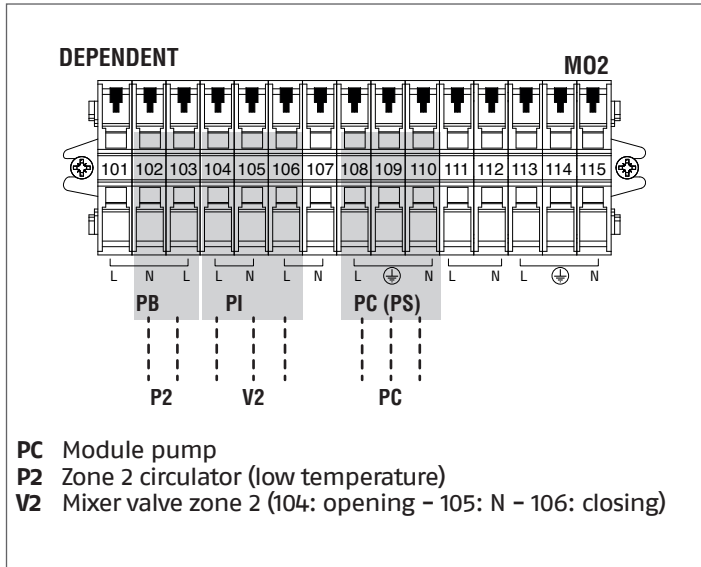

#### ACCESSORY CONNECTIONS FOR ADDITIONAL ZONE

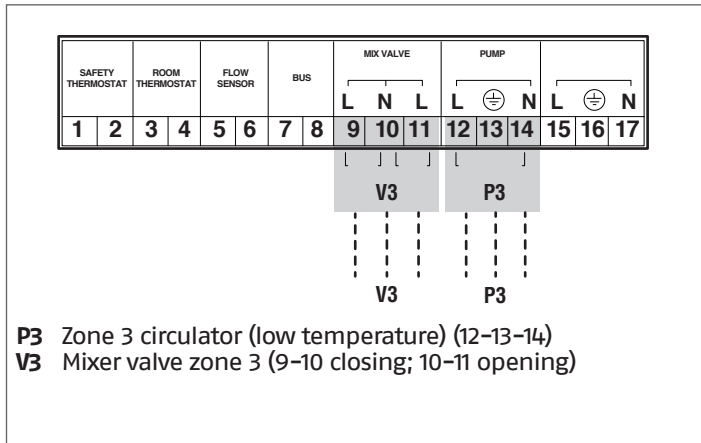

### 3.3.2 Sensor connections

#### MANAGING CONNECTIONS

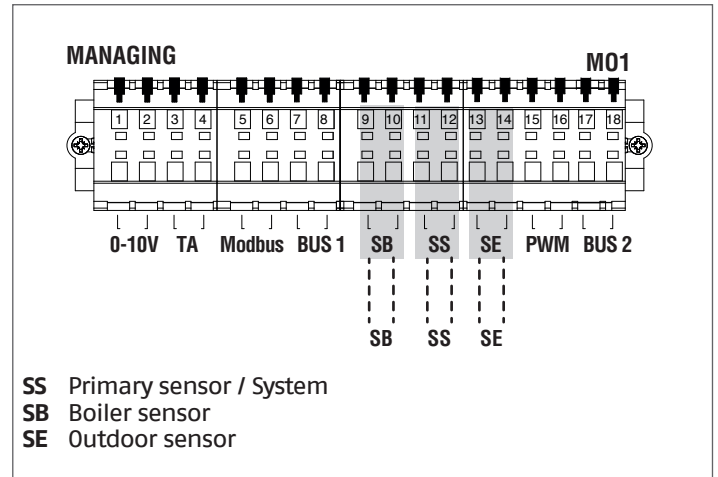

#### DEPENDENT CONNECTIONS

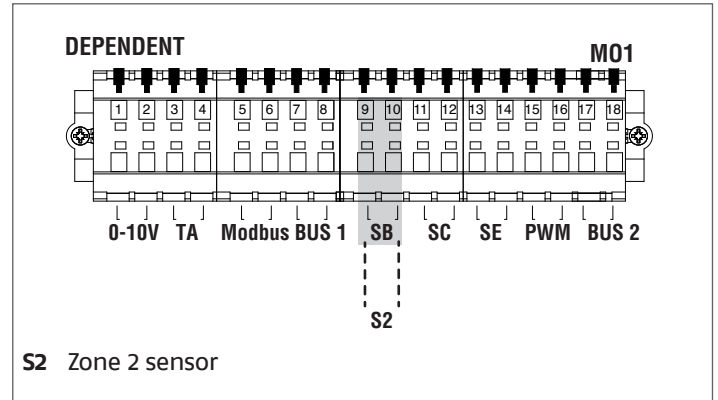

#### ACCESSORY CONNECTIONS FOR ADDITIONAL ZONE

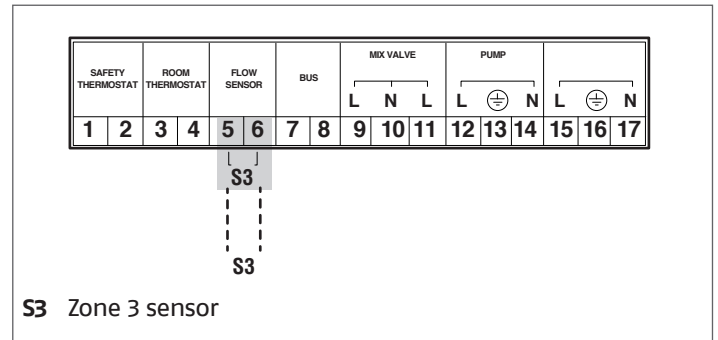

### 3.3.3 System parameters

#### Setting switch S1=OFF

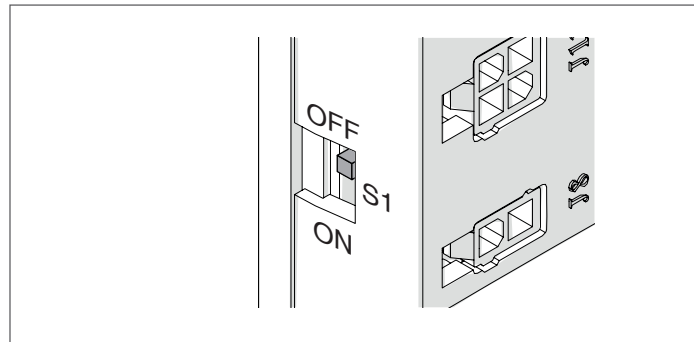

#### Essential parameters to be configured:

	Description	Default	Managing	Dependent
S1	BUS power supply	Off	(*)	(*)
Dip-switch	Module Address	All 0	1 to ON	2-10 to ON
Par.189	Module Address	Stand-alone	Managing	Dep. 2-3... 16
Par.147	No. cascade modules	8	TOT number of modules	-
Par.73	Boiler Address	Stand-alone	Stand-alone	(*)
Par.167	No. cascade boilers	1	(*)	(*)
Par.193	DHW for all	No	No	(*)
Par.184	No. active DHW units	16	No. modules needed for DHW	(*)

(\*) We do not recommend changing the default settings where not stipulated so as not to alter the operation of the appliance.

#### Specific parameters to be configured:

	Description	Default	Managing	Dependent
Par.79	Maximum setpoint decrease	2°C	(*)	(*)
Par.80	Maximum setpoint increase	5°C	(*)	(*)
Par.81	Waiting time before setpoint modulation	60 min	(*)	(*)
Par.86	P - Setpoint Modulation	50	(*)	(*)
Par.87	I - Setpoint Modulation	500	(*)	(*)
Par.7	Module switch-off hysteresis	5	> 10	> 10

(\*) Values recommended for optimum operation.

### 3.4 Block diagram 2: Cascade of modules with primary sensor (SS) and secondary (SC)

Recommended system diagram for refit systems, when replacing boilers with a high water content or in systems where the water flow rate in the secondary circuit is very different from that in the primary

Circuit with modules with their own pump, connected in cascade. Using the secondary sensor.

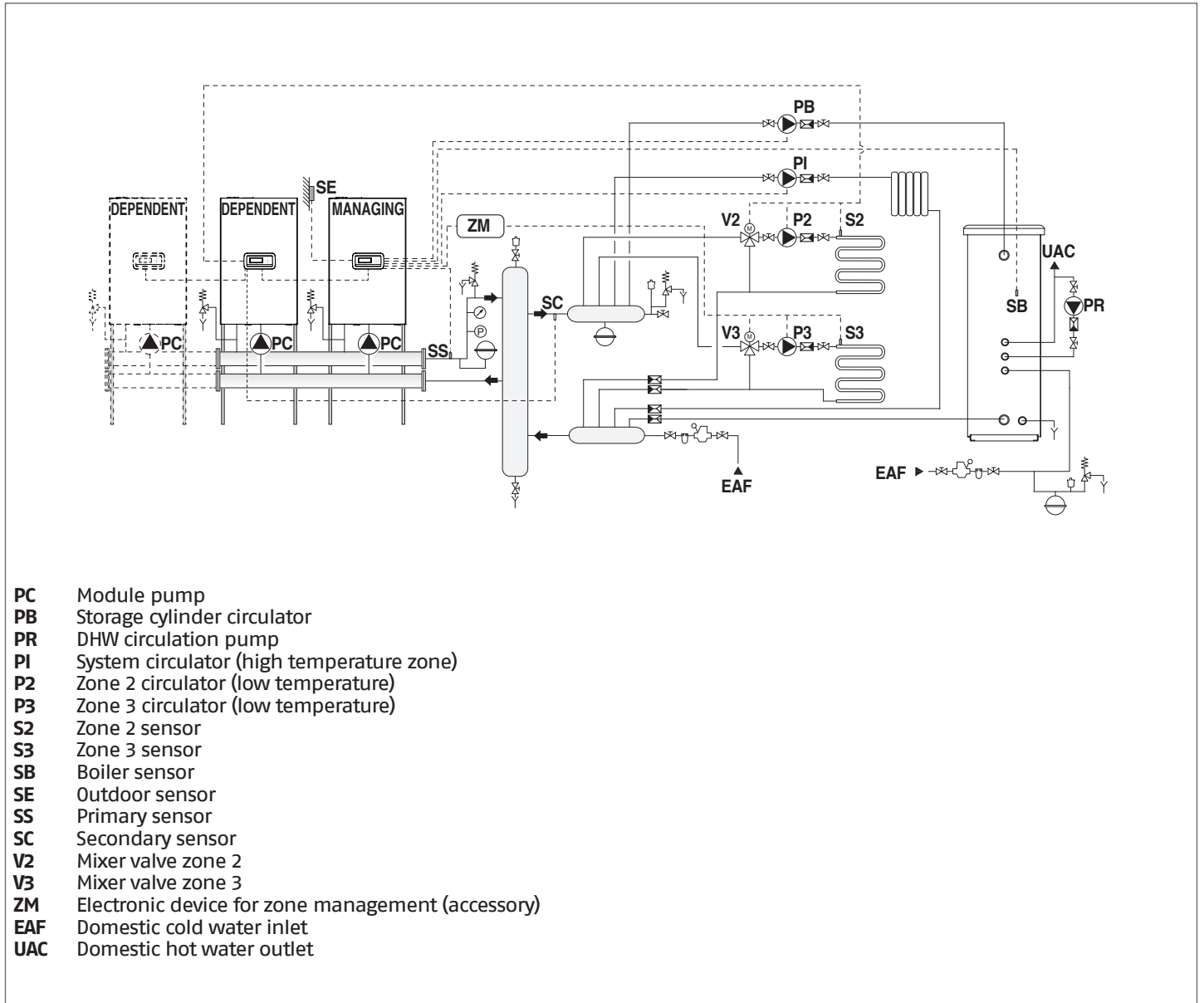

To address the modules and connect the BUS, see Chapter System management.

The modulation of each module depends on the delivery temperature of each unit. If the SC (secondary) does not reach the setpoint temperature "within a certain time", the setpoint temperature of the primary is raised.

SS (primary) manages solely the switching on and off of the individual modules.

### 3.4.1 Electrical power connections

#### MANAGING CONNECTIONS

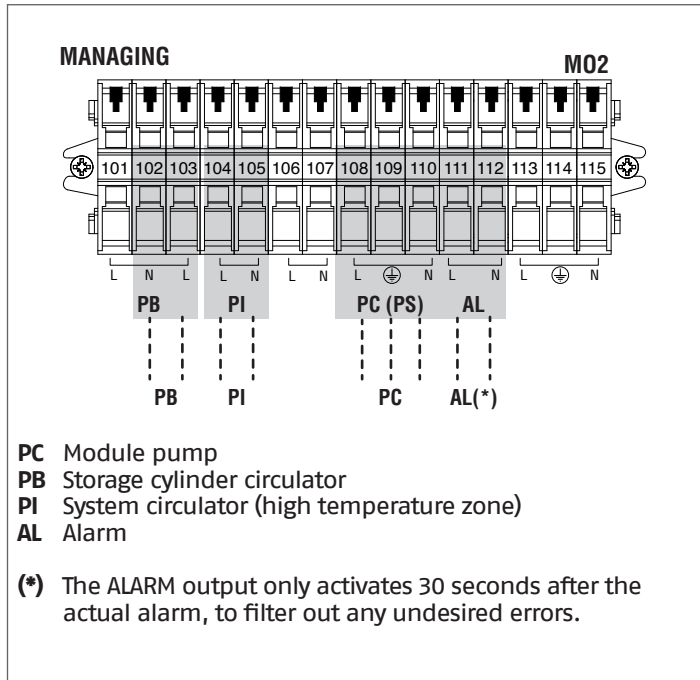

#### DEPENDENT CONNECTIONS

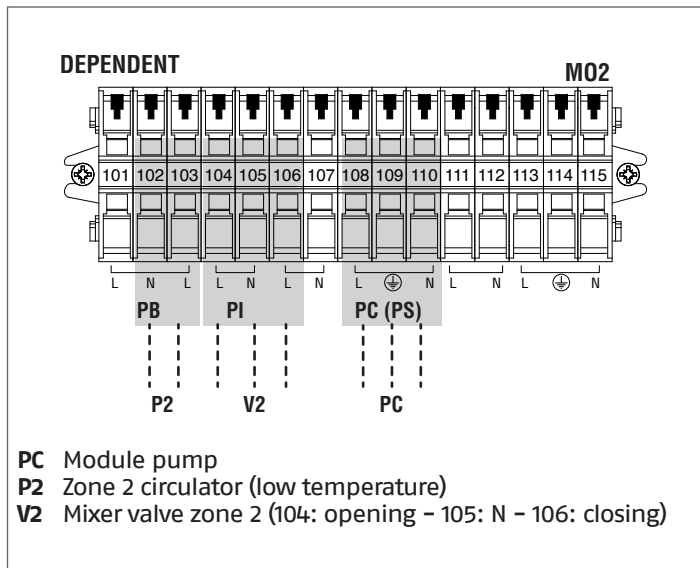

#### ACCESSORY CONNECTIONS FOR ADDITIONAL ZONE

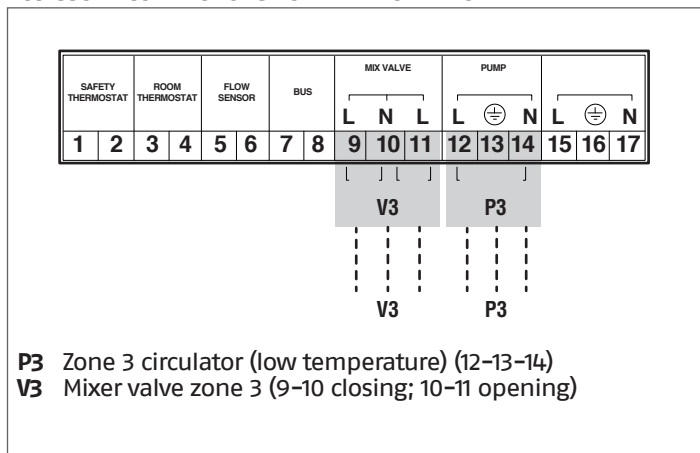

### 3.4.2 Sensor connections

#### MANAGING CONNECTIONS

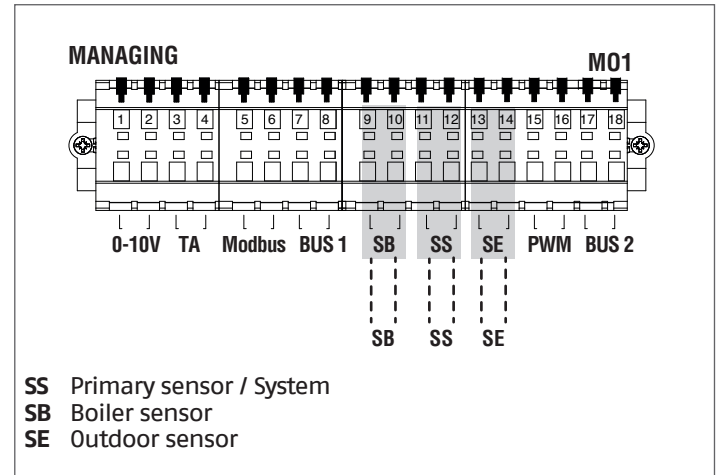

#### DEPENDENT CONNECTIONS

**!** Connections to be made on the first Dependent module only.

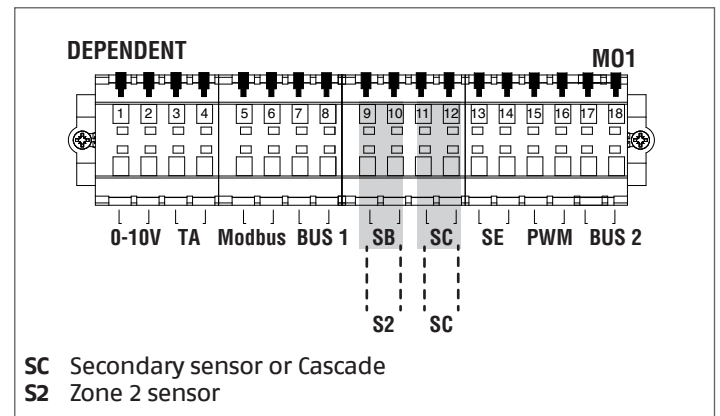

#### ACCESSORY CONNECTIONS FOR ADDITIONAL ZONE

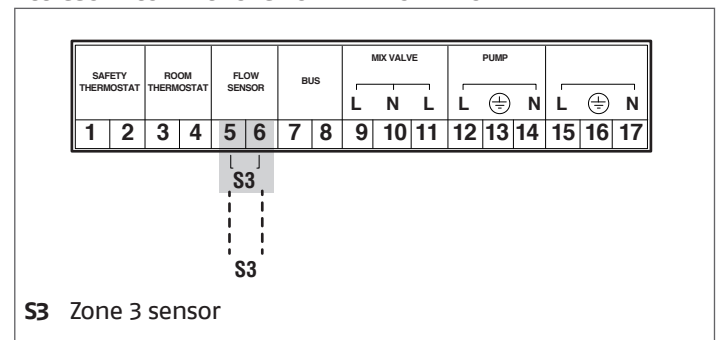

### 3.4.3 System parameters

#### Setting switch S1=OFF

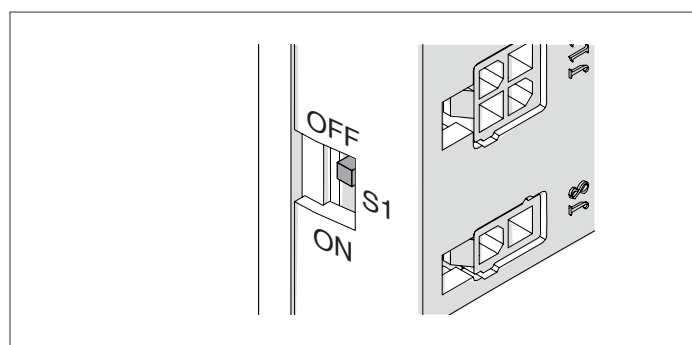

#### Essential parameters to be configured:

	Description	Default	Managing	Dependent
S1	BUS power supply	Off	(*)	(*)
Dip-switch	Module Address	All 0	1 to ON	2-10 to ON
Par.189	Module Address	Stand-alone	Managing	Dep. 2-3... 16
Par.147	No. cascade modules	8	TOT number of modules	(*)
Par.73	Boiler Address	Stand-alone	Managing	(*)
Par.167	No. cascade boilers	1	1	(*)
Par.193	DHW for All	No	No	(*)
Par.184	No. active DHW units	16	No. modules needed for DHW	(*)

(\*) We do not recommend changing the default settings where not stipulated so as not to alter the operation of the appliance.

#### Specific parameters to be configured:

	Description	Default	Managing	Dependent
Par.79	Maximum setpoint decrease	2°C	(*)	(*)
Par.80	Maximum setpoint increase	5°C	(*)	(*)
Par.81	Waiting time before setpoint modulation	60 min	(*)	(*)
Par.86	P - Setpoint Modulation	50	(*)	(*)
Par.87	I - Setpoint Modulation	500	(*)	(*)
Par.7	Module switch-off hysteresis	5	> 10	> 10

(\*) Values recommended for optimum operation.

### 3.5 Block diagram 3: Cascade of cascades

If the system is configured with at least two cascades, it is first and foremost necessary to define the Managing cascade in the system: Managing of the Managing

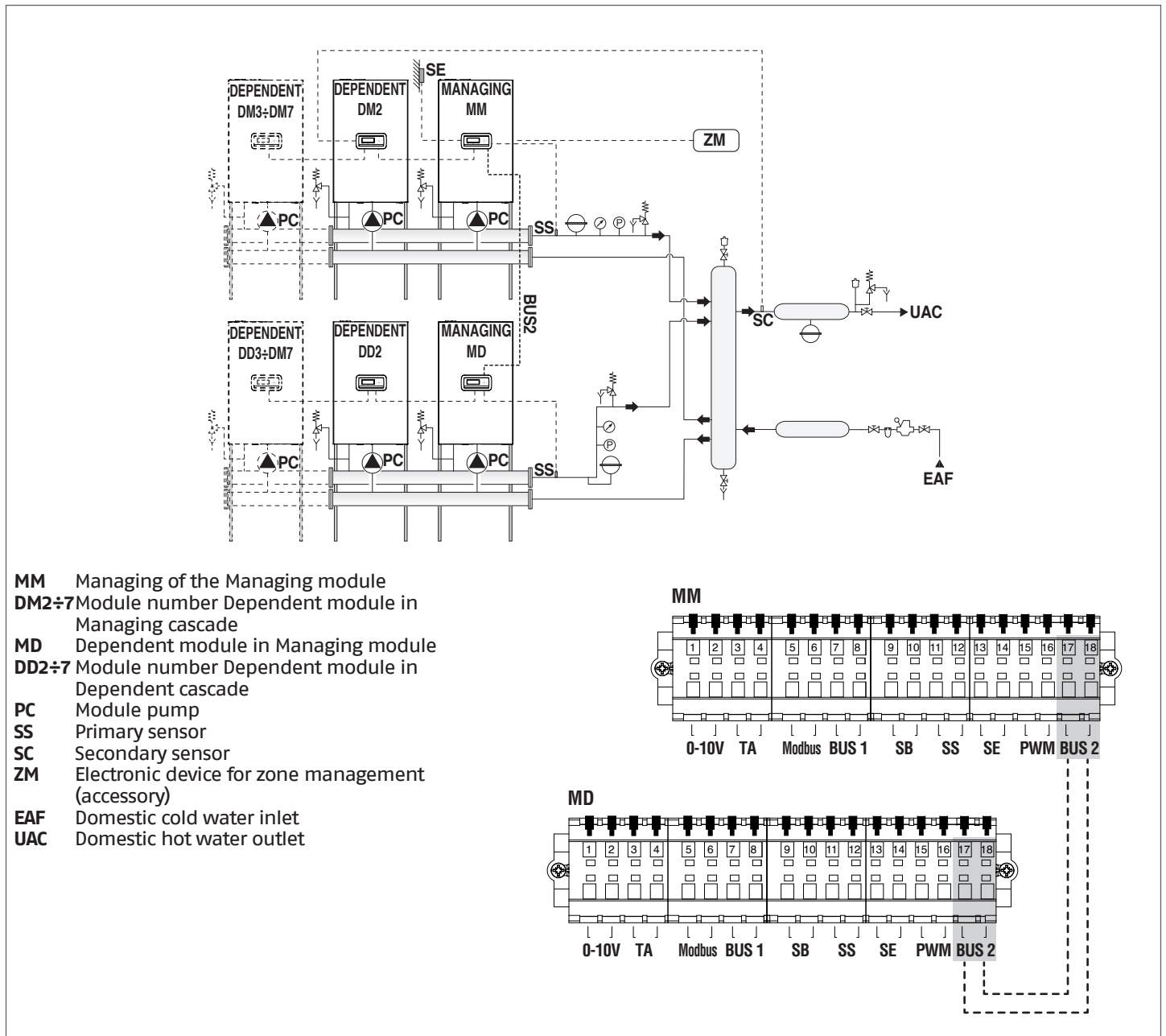

To address the modules and connect the BUS, see Chapter System management.

The modulation of each module depends on the delivery temperature of each unit. If the SC (secondary) does not reach the setpoint temperature "within a certain time", the setpoint temperature of the primary is raised.

SS (primary) manages solely the switching on and off of the individual modules.

**⚠** In this type of configuration it is NOT possible to manage further External zones and Dependent zones.

### 3.5.1 Sensor and data bus connections

#### MANAGING – DEPENDENT CONNECTIONS

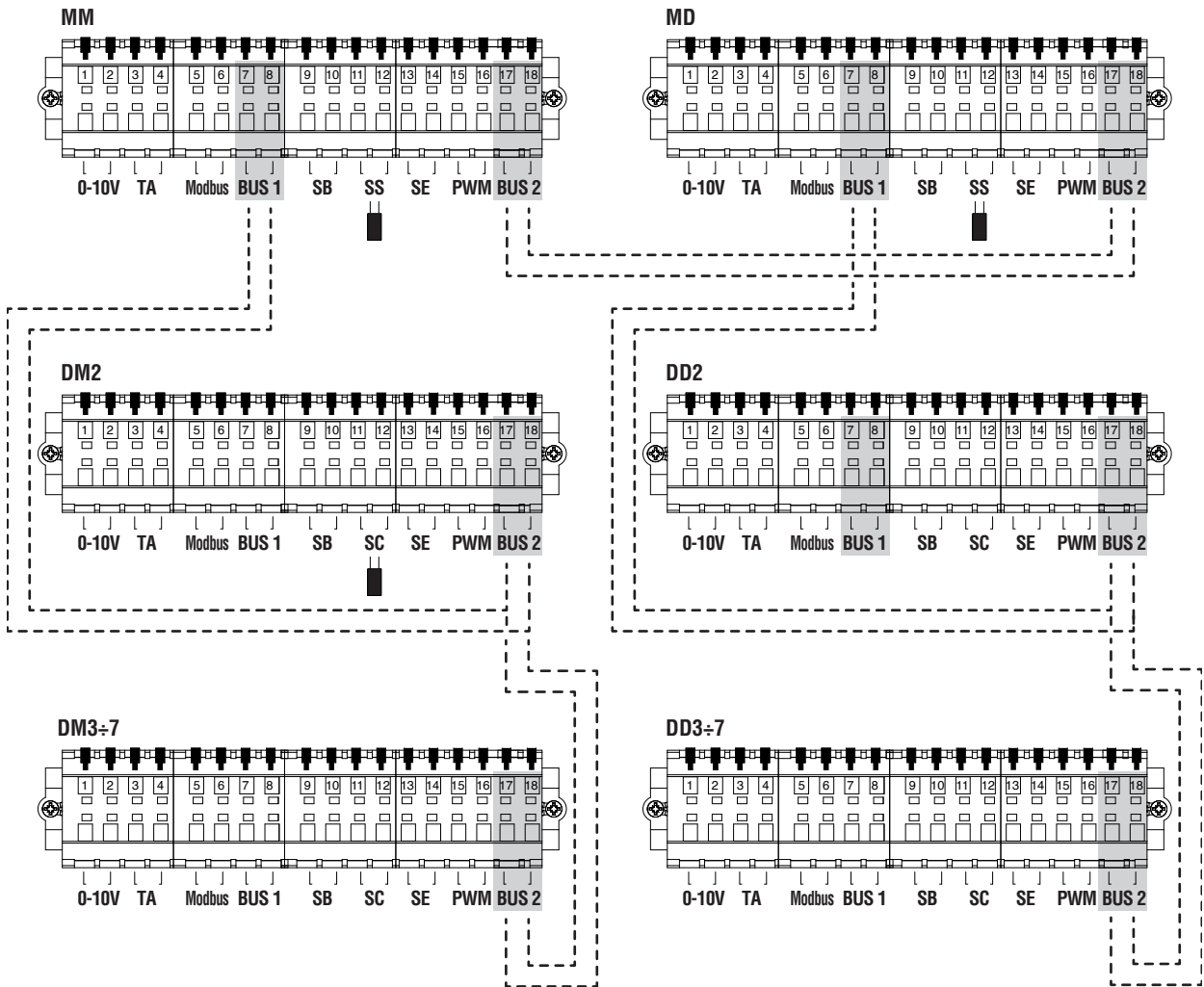

- MM** Managing module in Managing cascade
- DM2÷7** Module number Dependent module in Managing cascade
- MD** Managing module in Dependent cascade
- DD2÷7** Module number Dependent module in Dependent cascade
- SS** Primary sensor
- SC** Secondary sensor

### 3.5.2 System parameters

#### Setting switch S1=OFF

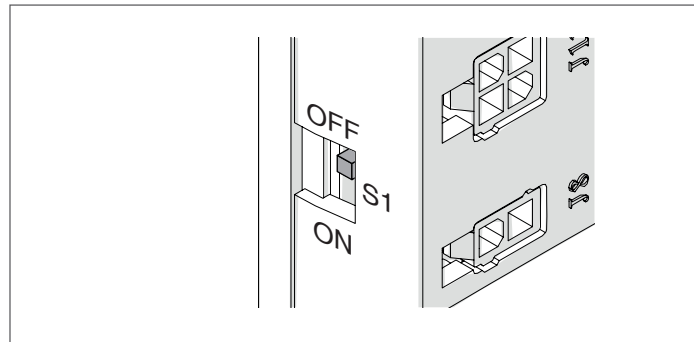

#### Essential parameters to be configured:

	Description	Default	Managing Cascade		Dependent Cascade	
			Managing	Dependent	Managing	Dependent
S1	BUS power supply	Off	On	Off	Off	Off
Dip-switch	Module Address	All 0	1 to 0N	2-8 to 0N	1 to 0N	2-8 to 0N
Par.189	Module Address	Stand-alone	Managing	Dep. 2-3... 16	Managing	Dep. 2-3... 16
Par.147	No. cascade modules	8	TOT number of Managing cascade modules	-	TOT number of Dependent cascade modules	-
Par.73	Boiler Address	Stand-alone	Managing	-	Dependent	-
Par.167	No. cascade boilers	1	TOT number of cascades	-	-	-
Par.193	DHW for All	No	Yes	-	-	-
Par.184	No. cascades used DHW	16	No. cascades needed for DHW	-	-	-

(\*) We do not recommend changing the default settings where not stipulated so as not to alter the operation of the appliance.

#### Specific parameters to be configured on Managing of each cascade (MM - MD):

	Description	Default	Managing (MM)	Dependent (MD)
Par.79	Maximum setpoint decrease	2 °C	(*)	(*)
Par.80	Maximum setpoint increase	5 °C	(*)	(*)
Par.81	Waiting time before setpoint modulation	60 min	(*)	(*)
Par.7	Module switch-off hysteresis	5 °C	> 10	> 10
Par. XXX	Cascade mode	Basic	Full	Full

(\*) Values recommended for optimum operation.

**Specific parameters to be configured on Managing in the Managing cascade (MM):**

	Description	Default	Managing (MM)
Par.147	Number of modules in cascade	8	1...10
Par.158	Delay Per Start Next Blr.	1275	Par.75 x (No. of modules connected to MM + 1)
Par.159	Delay Per Stop Next Blr.	1275	Par.76 x (No. of modules connected to MM + 1)
Par.160	Next Quick Start Delay	400	Par.142 x (No. of modules connected to MM + 1)
Par.161	Next Quick Stop Delay	240	Par.143 x (No. of modules connected to MM + 1)
Par.167	Number of boilers connected (cascade of cascades)	1	1...8
Par.169	Maximum setpoint decrease	2°C	(*)
Par.170	Maximum setpoint increase	5°C	(*)
Par.171	Waiting time before setpoint modulation	40 min	(*)

(\*) Values recommended for optimum operation.

## 4 SYSTEM MANAGEMENT

Communication between all the modules installed is a fundamental aspect in a system with multiple modules.

The essential steps for configuration are:

- allow the Managing module to recognise which and how many dependent modules are present in the system. Act on the dip-switch
- connect the modules with a BUS cable to allow communication between the control units.

### 4.1 Setting the type of module addressing

Parameter 194 is used to set the type of addressing.

Press the MENU key and select "Settings" with the ▲ / ▼ keys

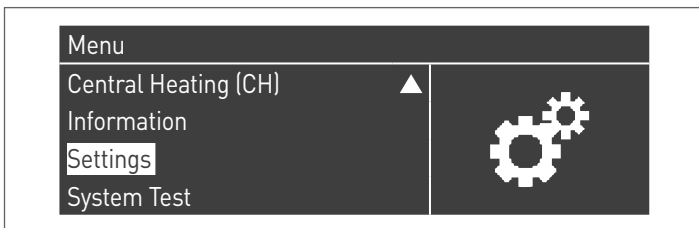

Confirm with the ● key and select "Boiler settings" with the ▲ / ▼ keys



- Select "Module Cascade Settings" using keys ▲ / ▼ and press ●

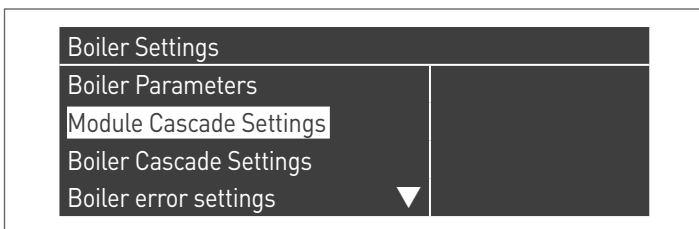

### ENABLE PARAMETER

- Select "Dipswitch Config" using keys ▲ / ▼ and press ●
- Use keys ▲ / ▼ to set in "Enabled" and press ● to confirm

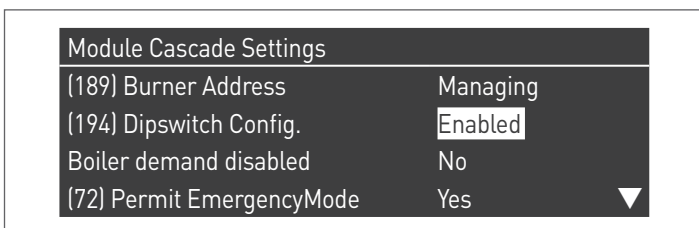

### DISABLE PARAMETER

- Select "Dipswitch Config" using keys ▲ / ▼ and press ●
- Use keys ▲ / ▼ to set in "Disabled" and press ● to confirm

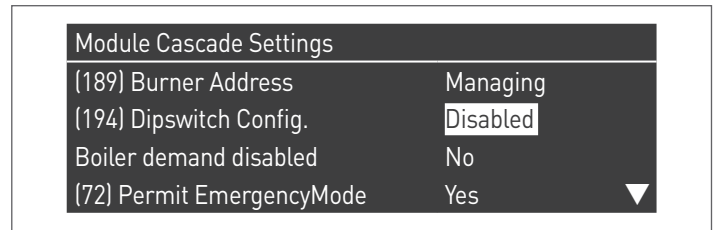

### 4.2 Module addressing via dip switches

Parameter 194 must be set to "Enabled" before proceeding with the changes (see paragraph "Setting the type of module addressing").

The dip switches of all the modules in the system must be set, and each must be set with an unequivocal sequence. This way the controller of the Managing module will be able to recognise which modules are present in the system.

To access the dip-switches, open the hatch using a flat-bladed screwdriver.

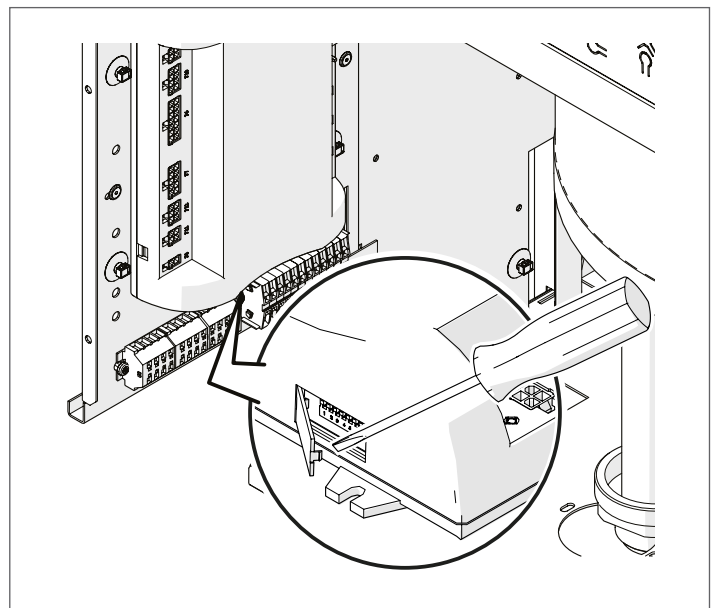

**⚠** The setting must be carried out on each module. For configuration of the individual module, refer to the following table.

Key	
	Dip switch ON
	Dip switch OFF
Setting the Dip-switch	Module Configuration
	Stand-alone module (all the dip-switches set to OFF, configuration not used in cascade)
	1st module (Managing)

Setting the Dip-switch	Module Configuration
	2nd module (Dependent)
	3rd module (Dependent)
	4th module (Dependent)
⇩	⇩
	8th module (Dependent)
	9th module (Dependent)
	10th module (Dependent)

- ⚠** If two modules have the same Dip-switch setting, the Managing module will signal a communication error and the cascade will not work correctly.
- ⚠** A module will not be considered if it has the setting of all the Dip-switches set to OFF.

### 4.3 Address configuration via Display

The board address can also be set from the PB display.

Parameter 194 must be set to "Disabled" before proceeding with the changes (see chap. Setting the type of module addressing).

After entering the setting:

- Select "(189) Module address" using keys ▲ / ▼ and press ●
- Use keys ▲ / ▼ to set the module address (Managing, Dependent 2, Dependent 3, ..., Dependent 15) and press ● to confirm

Module Cascade Settings	
(189) Burner Address	Managing
(194) Dipswitch Config.	Disabled
Boiler demand disabled	No
(72) Permit EmergencyMode	Yes ▼

**NOTE** The configuration of the physical dip switches is ignored.

### 4.4 Bus connections

Identify the terminals located below the controller. The bus connections are to be made on the low voltage terminal board (M01).

#### Module terminal board

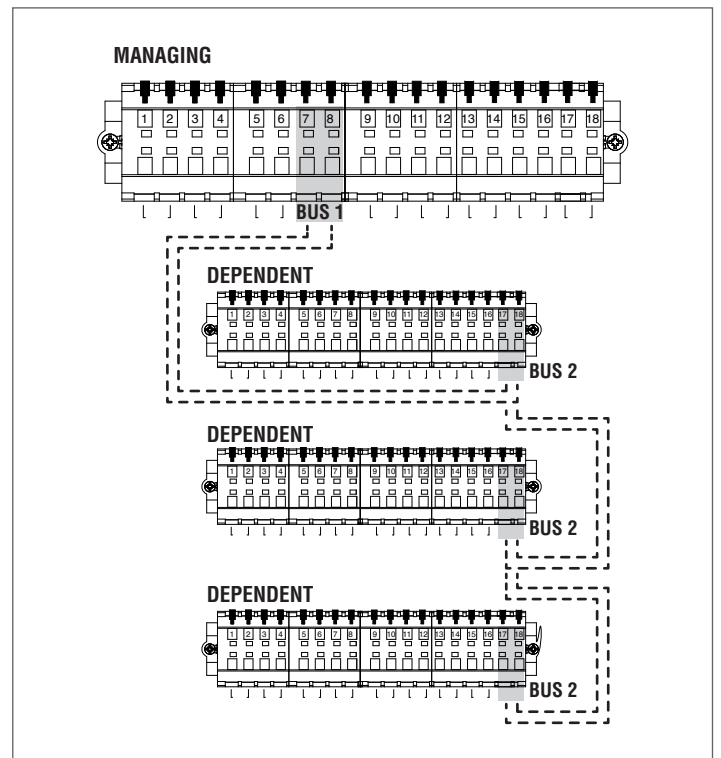
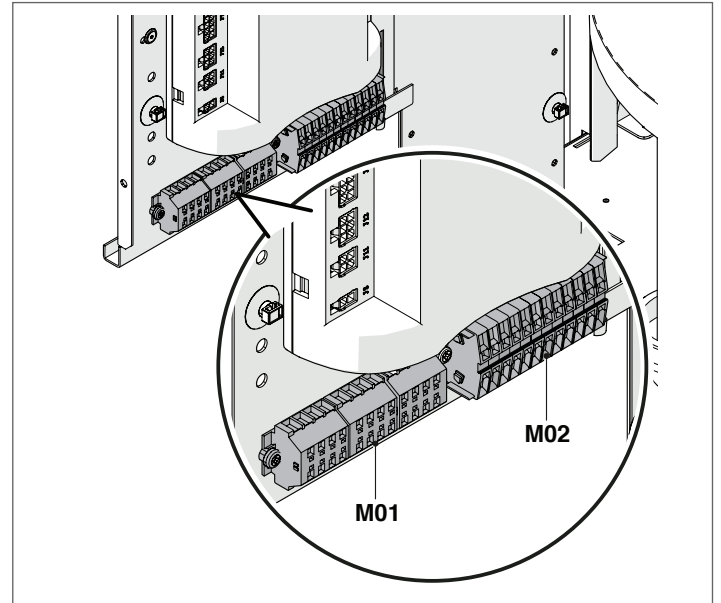

- ⚠** The bus connection to the dependent modules must be made in parallel without the closing terminal which would cause a short circuit.

### 4.5 Connection to External Zone controller

**⚠** With a Cascade of Cascades it is NOT possible to manage further external zones.

The mixed zone controller connected to the system must be set with a specific number of recognition actions, so that the electronic board of the module recognises which zone is making the heat request.

The number of recognition actions is set with the help of the jumpers to be applied to each pair of pins.

**⚠** The setting must be carried out on each board of the additional zone accessory. To assign the required number to the additional zone, refer to the following table, applying the jumpers to the positions illustrated from 1-4.

**⚠** If two zones have the same address, one of the two will not be recognised.

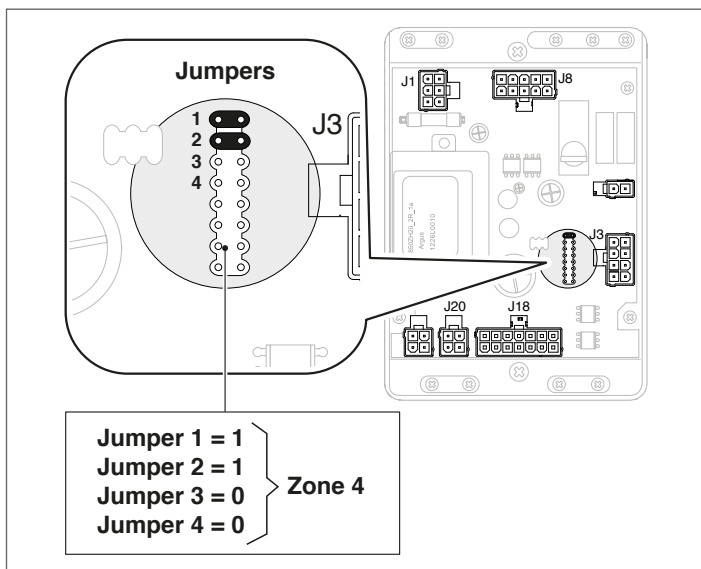

Jumpers				Zone number
4	3	2	1	
0	0	0	0	1
0	0	0	1	2
0	0	1	0	3
0	0	1	1	4
0	1	0	0	5
0	1	0	1	6
0	1	1	0	7
0	1	1	1	8
1	0	0	0	9
1	0	0	1	10
1	0	1	0	11
1	0	1	1	12
1	1	0	0	13
1	1	0	1	14
1	1	1	0	15
1	1	1	1	16

**⚠** To configure the parameters, refer to the manual of the kit provided.

### 4.6 Removing external zone

To remove an External zone, enter the "Information" menu:

- enter "Status zone dep.";
- select the number of the dependent zone;
- The "Detection" field will indicate "NO";
- select "Remove zone" changing to "YES" and confirm.

Now in the "Settings" and "Information" menus the dependent zone will no longer be displayed.

The electronic control of the module will automatically check which zones are connected to the bus.

The menu items of the zone in the electronic control of the module will be available when 1 or more zone management devices are detected.

The electronic control of the module remembers the zone number detected when a device is connected.

The zone number detected is not automatically removed when the corresponding accessory is no longer connected.

The zone number needs to be removed manually.

#### Removing the zone number

- remove the bus connection of the zone to be deleted;
- access the Settings/Zone Config./Zone;
- select the disconnected zone;
- go to Remove Zone;
- press the ► key to highlight the values, change them to "Yes" with the ▲ / ▼ keys, press the ● key to confirm and remove the zone from the display menus.

Example:

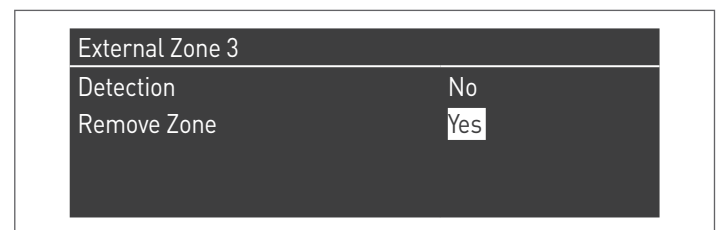

## 4.7 Configuration of Dependent zones

**⚠** Configuration not possible with a Cascade of Cascades.

If used on a cascade system, with heating zone control using DEPENDENT module, after carrying out the connections as described in the Cascade Manual, the following modifications need to be made.

On the display of the Dependent module to which the zone is connected:

Par. 97

- if configured with value = 1 (use with circulator) it must be changed to value = 9
- if configured with value = 2 (use with 2-way valve) it must be changed to value = 8

**⚠** The 97=8 configuration CANNOT be applied to models with a boiler circulator installed as standard.

Par. 205

By default the parameter is disabled. To enable the recognition of the zone the value must be changed from "DIS" to "ENA" and confirmed.

When the modifications are complete the following new functions will be available on the display of the device:

- in the "Information" menu the number of the connected zone appears (zone of the dependent), from where it is possible to display information about it;
- in the "Settings" menu two new lines will be displayed:
  - "Config. Zone Dep."
  - "Clim. Curve Zone Dep."
- The following new row will appear in the "Clock program" menu:
  - "Program CH Zone Dep."

### Cascade connection

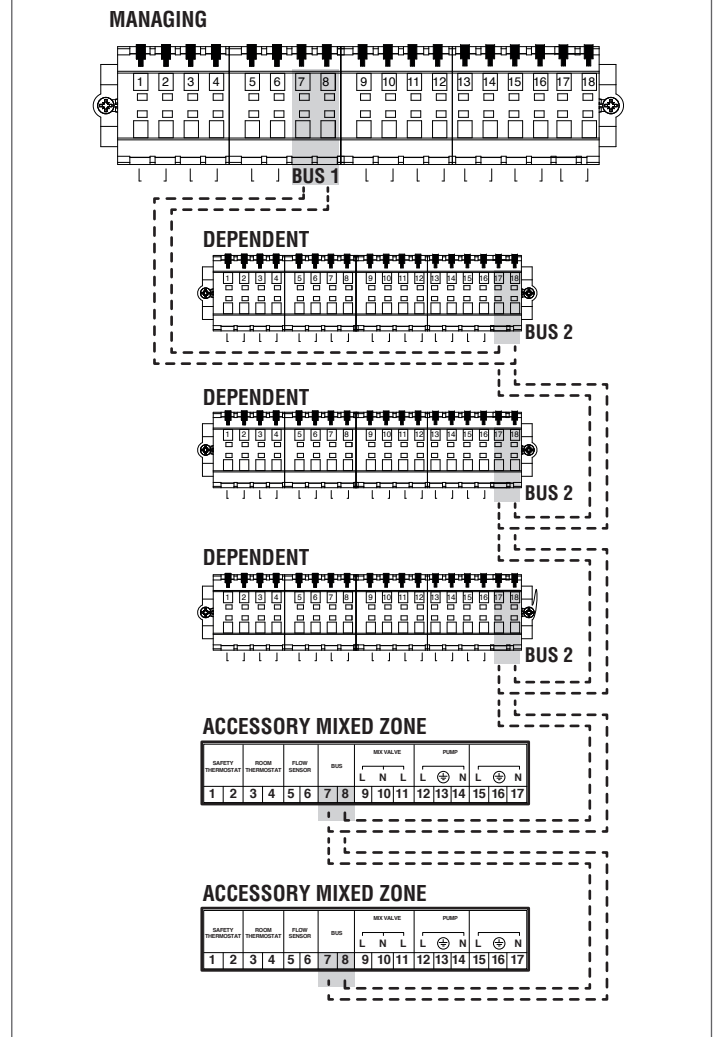

### 4.7.1 Deleting dependent zone

To remove a Dependent zone operate in the reverse way to its installation:

- enter the parameters menu and select the par. 205. Change its value from "ENA" to "DIS";
- change the par. 97. If par. 97 = 9 change to = 1; if par. 97 = 8 change to = 2.

## 5 COMMISSIONING AND MAINTENANCE

### 5.1 Repositioning the front panels

Before putting the appliance into service, make sure that all the modules have been reassembled with their own front panel:

- 1 Insert the panel into the seats on the points (B).
- 2 Push it forwards until contact is made and then secure using the designated screw (A).

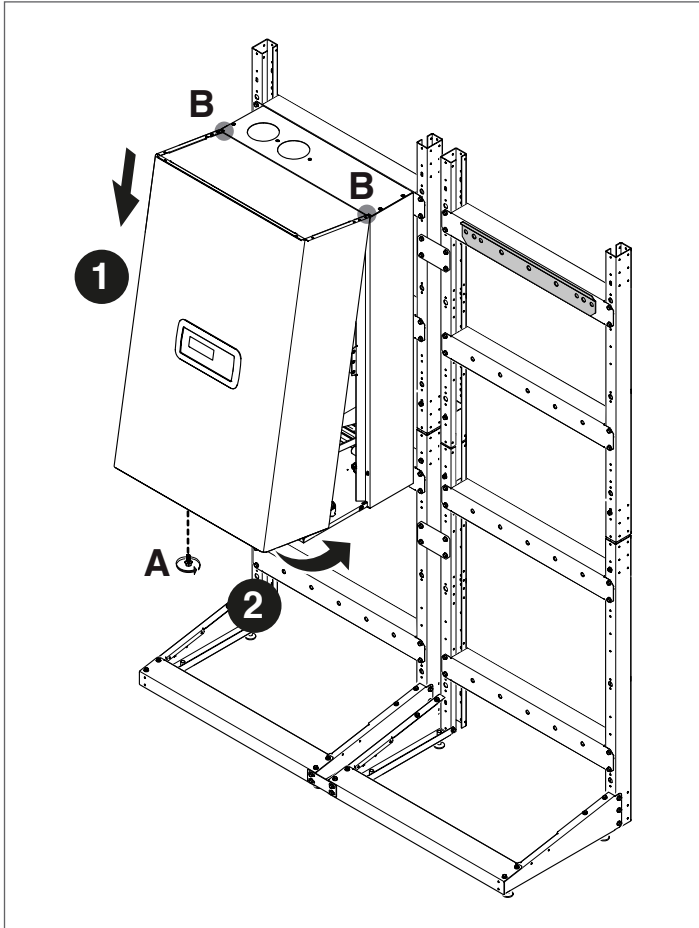

### 5.2 Putting the system into service

The first time the **Condexa PRO** is used, the following checks and operations must be carried out:

- Check that the gas cock and heating water cock are open

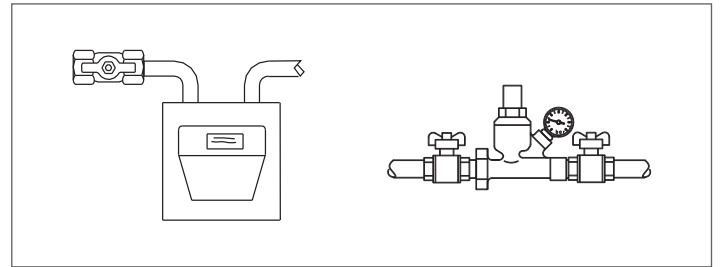

- Check that the pressure of the hydraulic circuit when cold is always greater than 1 bar and less than the maximum limit permitted for the system

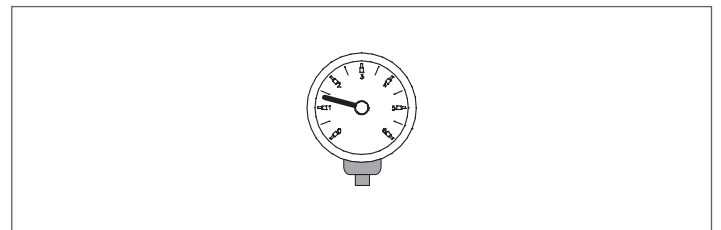

- Set the main switch of the system to ON and the main switch of all the modules to (I), starting with the Managing module.

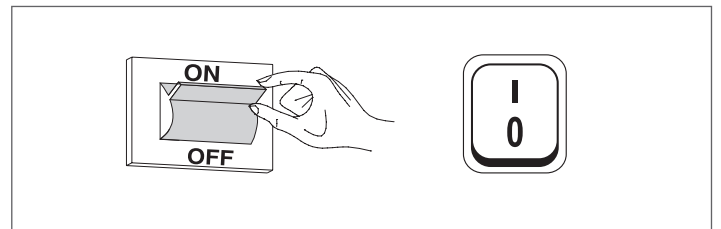

## 6 ELECTRONIC CONTROL

The electronic control operator interface menu is a multi-level one. Navigation between the various levels is shown in the figures below. Keep in mind that the operating parameters of the module are identified with a number, while other additional functions are only descriptive.

Level 0 displays the Home Screen (Home). Level 1 displays the Main Menu screen. Subsequent levels are active based on the available submenus. For the complete structure see paragraph "Setting parameters of the additional zone". For how to access and change the parameters, see the picture on the next page. Parameters intended for the Installer are accessible only after entering the security password (see paragraph "Setting parameters of the additional zone").

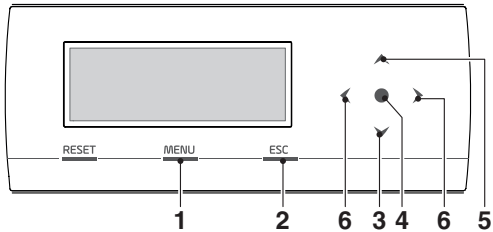

- 1 switches on the main menu
- 2 in menu navigation, it enables you to exit a menu item and go back to the previous one
- 3 supports selecting menus or parameters or decreasing numeric values
- 4 enter
- 5 supports selecting menus or parameters or increasing numeric values
- 6 supports moving to the RH/LH area of the display

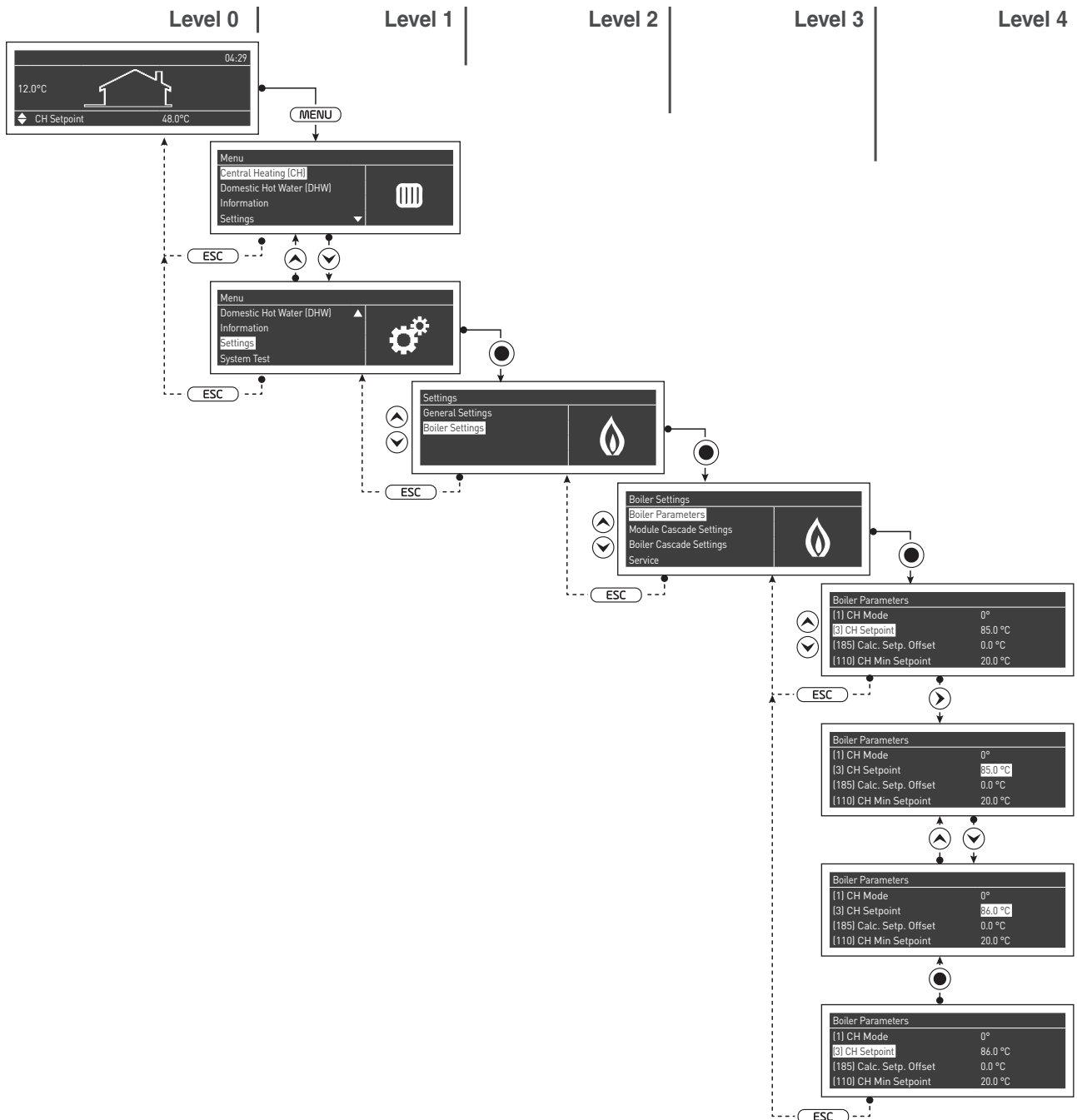

6.2.1 Menu structure

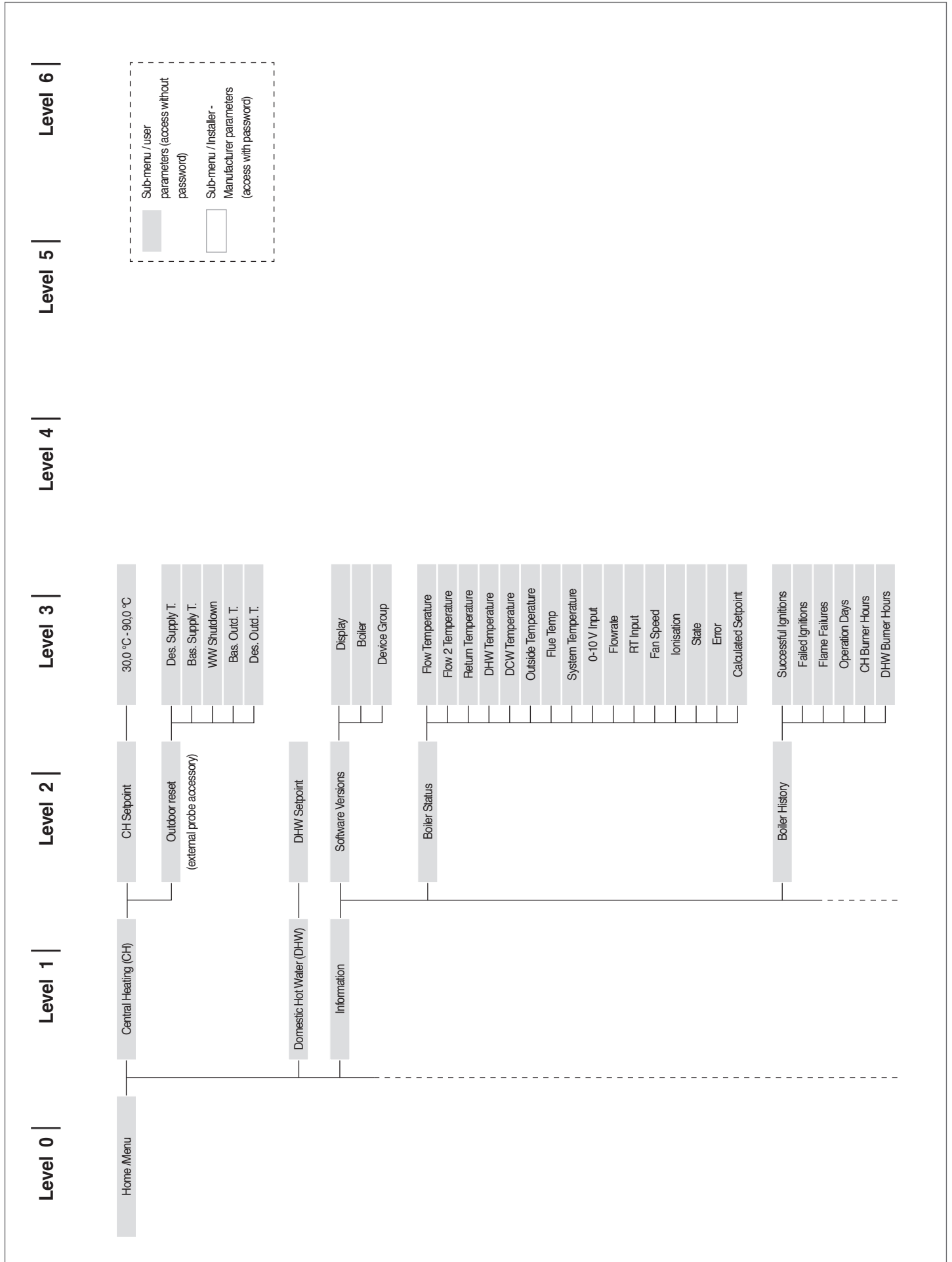

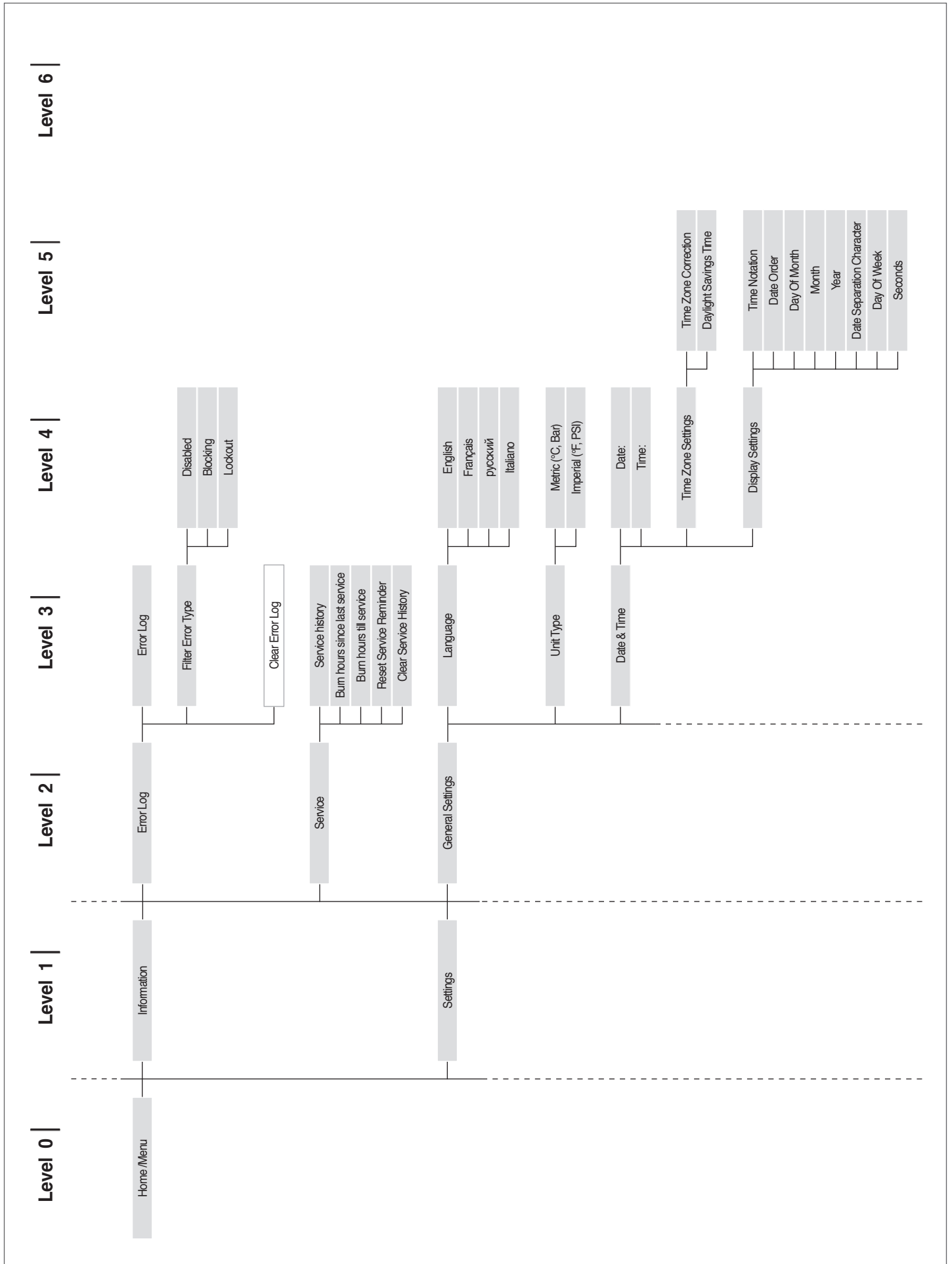

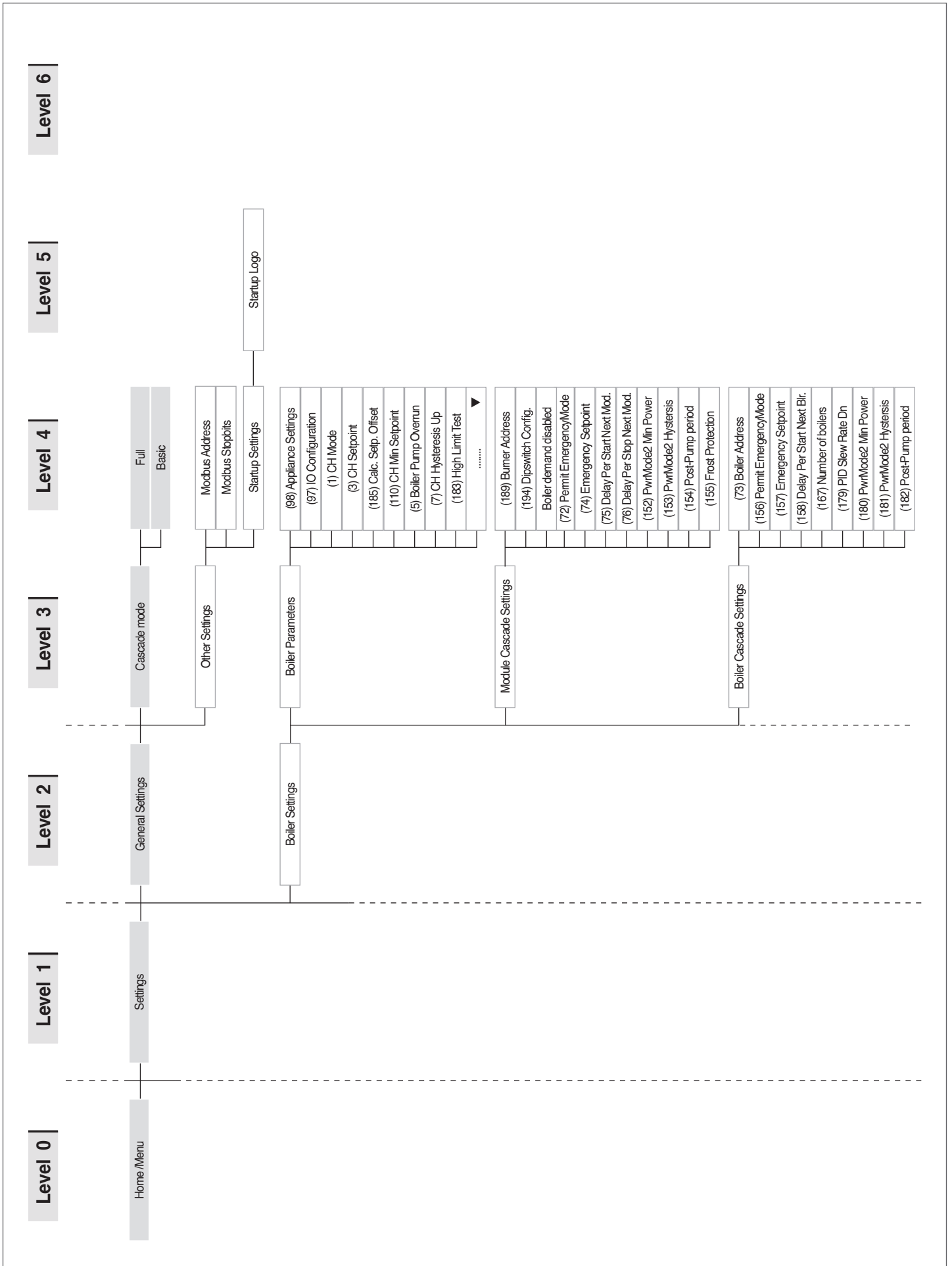

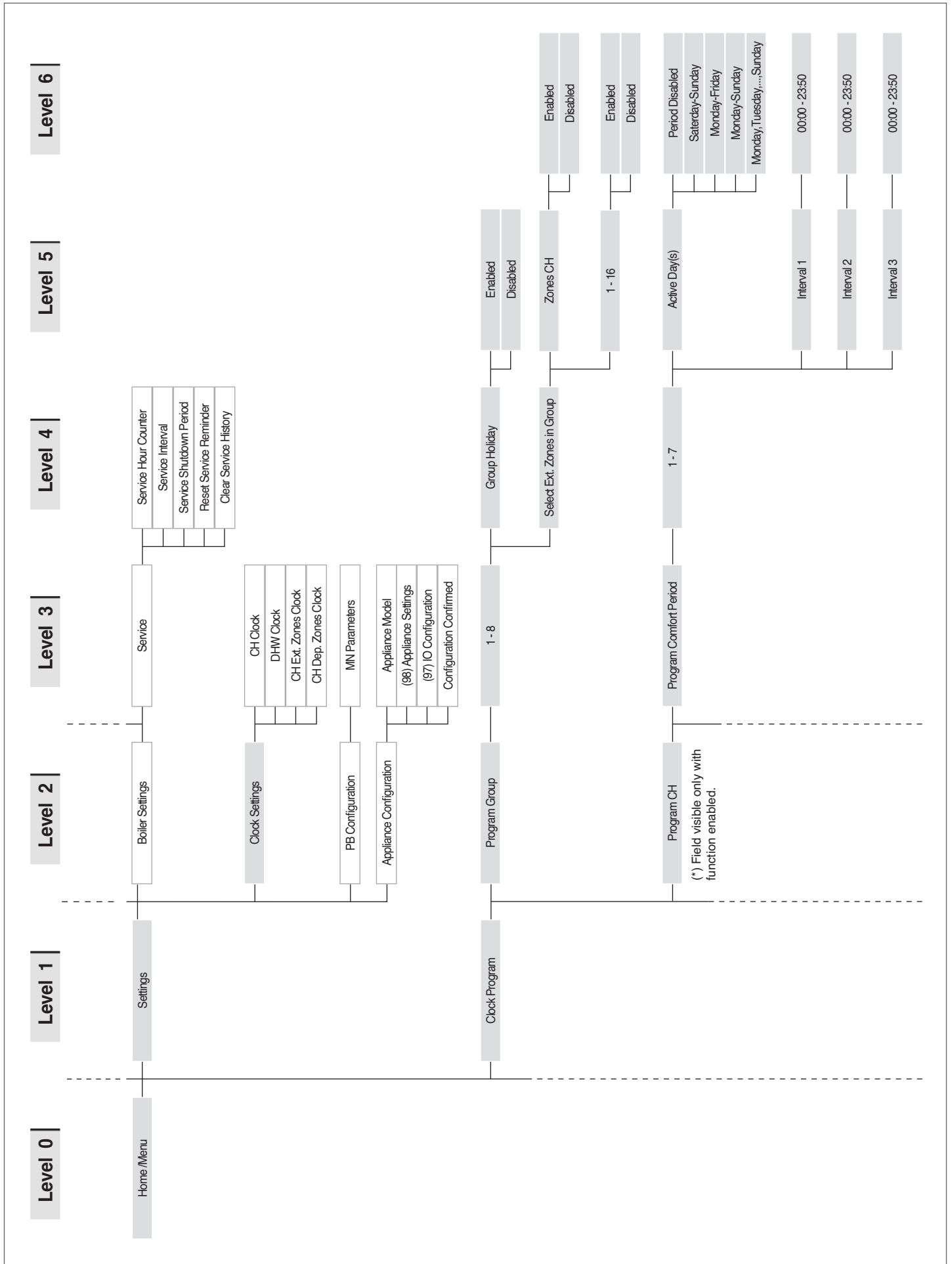

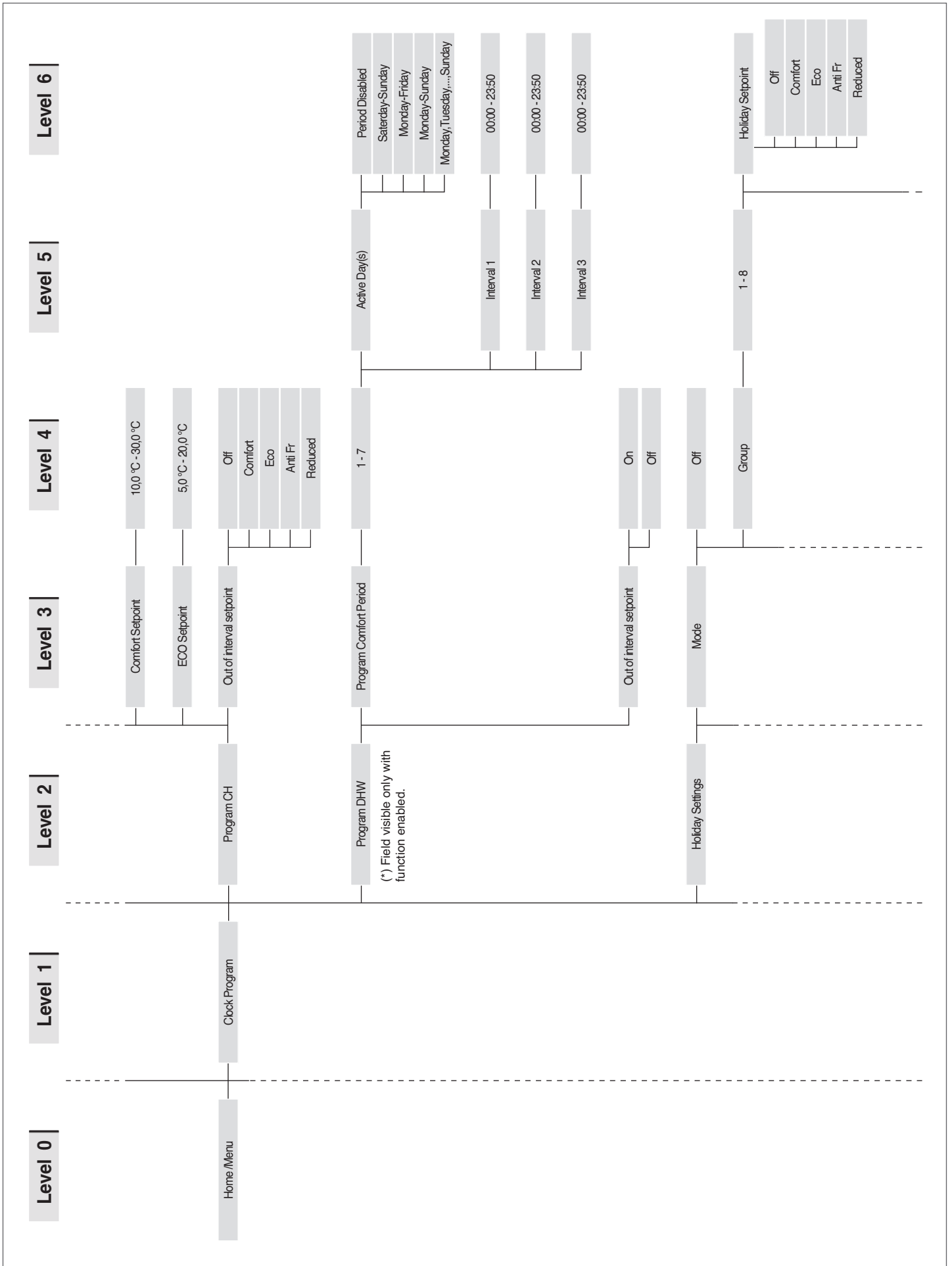

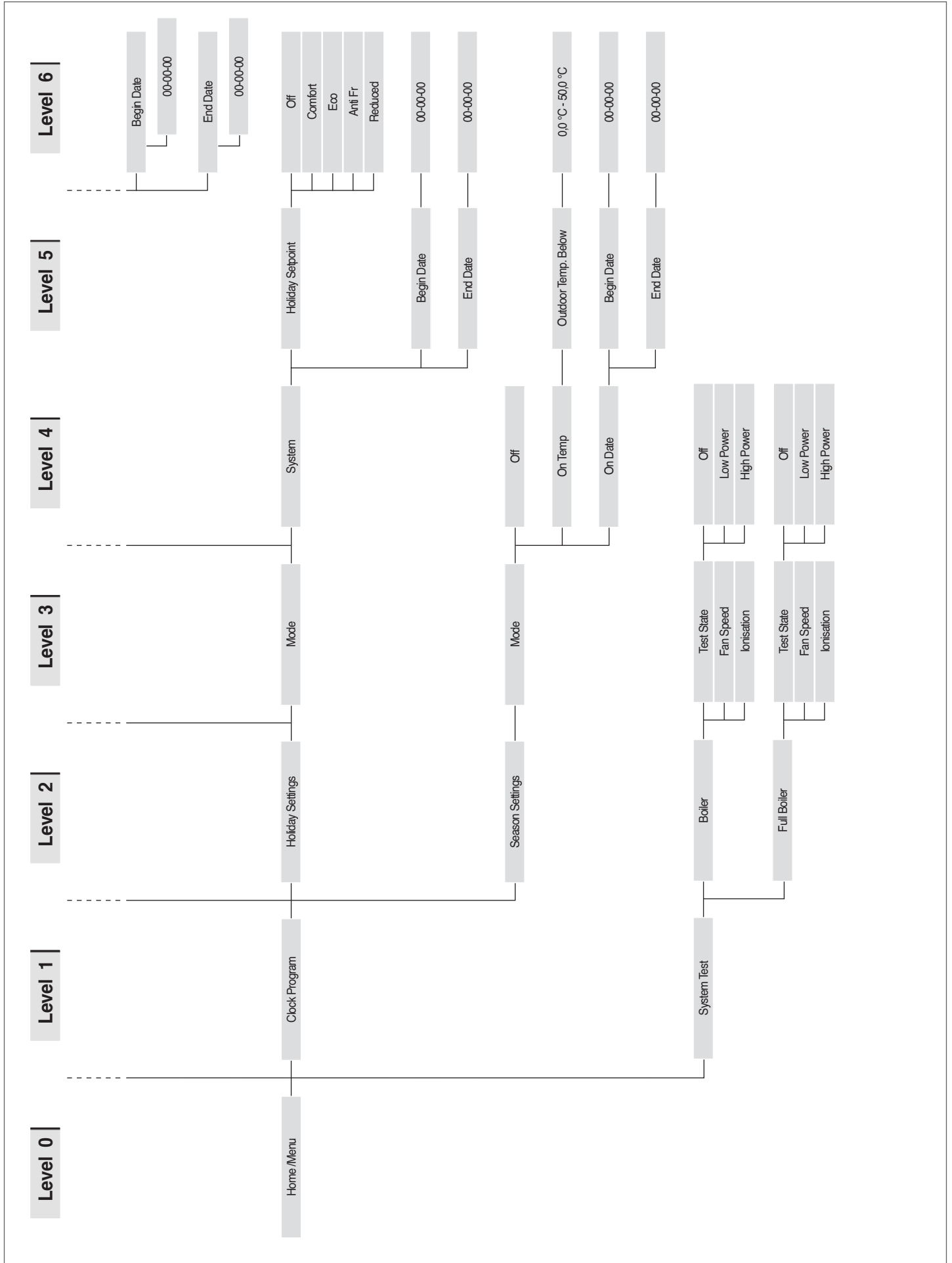

## 6.1 Parameters specific to cascade systems

Parameters are listed base on the reference menu.

### Reference Menu

<b>M1</b>	Parameters Menu
<b>M2</b>	Cascaded module configuration menu
<b>M3</b>	Cascaded boiler configuration menu
<b>M4</b>	Appliance configuration menu

### Access type

<b>U</b>	End user
<b>I</b>	Installer
<b>0</b>	Manufacturer

Menu	Par. No.	Display visualisation	Description	Range	Factory setting	UM	Access type	Category
M2	189	Burner Address	It is used to address the module.	Stand-alone (0) Managing (1) Dependent (2...16)	Stand-alone (0)		I	DHW
M2	194	Dipswitch Config.	Enable or disable the dipswitch function.	Enabled/Disabled	Disabled		I	Cascade
M2		Boiler demand disabled	All requests for this boiler are disabled.	Yes/No	No		I	Cascade
M2	72	Permit Emergency Mode	Activates the emergency mode. This mode comes on when communication between Managing and the primary circuit's probe is lost. In this event, if Par. 72 is set to "Yes", the cascade is initiated, working to the fixed set-point determined by Par. 74.	Yes/No	Yes		U	Cascade
M2	74	Emergency Set-point	Set-point active in emergency mode.	20...90	70	°C	I	Cascade
M2	75	Delay Per Start Next Mod.	Defines the stand-by time in seconds to restart the subsequent cascade module in normal start mode.	5...255	120	Sec.	I	Cascade
M2	76	Delay Per Stop Next Mod.	Defines the stand-by time in seconds to switch off the last cascade module on in normal Off mode.	5...255	30	Sec.	I	Cascade
M2	142	Delay Quick Start Next	Defines the stand-by time in seconds to restart the next cascade module in quick start mode.	5...255	60	Sec.	I	Cascade
M2	143	Delay Quick Stop Next	Defines the stand-by time in seconds to switch off the last cascade module on in Quick Stop mode.	5...255	15	Sec.	I	Cascade
M2	77	Hyst. Down Start Module	Defines by how many degrees the temperature measured by the primary circuit's probe must fall below the set-point in order for the subsequent module to be started after the time interval set by Par. 75.	0...40	5	°C	I	Cascade
M2	78	Hyst. Up Stop Module	Defines by how many degrees the temperature measured by the primary circuit's probe must go above the set-point in order for the subsequent module to be switched off after the time interval set by Par. 76.	0...40	4	°C	I	Cascade
M2	144	Hyst. Down Quick Start	Defines by how many degrees the temperature measured by the primary circuit's probe must go below the set-point in order for the subsequent module to be started after the time interval set by Par. 142 (quick-start mode).	0...40	20	°C	I	Cascade
M2	145	Hyst. Up Quick Stop	Defines by how many degrees the temperature measured by the primary circuit's probe must go above the set-point in order for the subsequent module to be switched off after the time interval set by Par. 143 (quick stop mode).	0...40	6	°C	I	Cascade

Menu	Par. No.	Display visualisation	Description	Range	Factory setting	UM	Access type	Category
M2	146	Hyst. Up Stop All	Defines by how many degrees the temperature measured by the primary circuit's probe must go above the set-point in order for all "On" modules to be switched off at the same time.	0...40	8	°C	I	Cascade
M2	147	Number of Units	Defines the number of modules of which the cascade consists.	1...16	8		I	Cascade
M2	148	Power Mode	Defines the cascade operation mode. 0 = Disabled 1 = Min burners 2 = Max burners	0,1,2	2		I	Cascade
M2	79	Max. Setp. Offset Down	Defines the maximum decrease in the primary circuit's cascade set-point. Is based on the primary circuit's probe reading.	0...40	2	°C	I	Cascade
M2	80	Max. Setp. Offset Up	Defines the maximum increase in the primary circuit's cascade set-point. Is based on the primary circuit's probe reading.	0...40	5	°C	I	Cascade
M2	81	Start Mod. Delay Fact.	Defines the time in minutes from the moment the demand is triggered until the activation of the set-point increases or decreases provided for by Par. 79 e 80.	0...60	60	Min.	I	Cascade
M2	82	Next Module Start Rate	It defines the minimum power for at least one of the modules in the cascade in order for the next module to be switched on (if the other conditions linked to Par. 75 and 77 are met).	10...100	80	%	I	Cascade
M2	83	Next Module Stop Rate	It defines the maximum power for all the modules in the cascade in order for the last module on to be switched off (if the other conditions linked to Par. 76 and 78 are met).	10...100	25	%	I	Cascade
M2	84	Module Rotation Interval	It defines the time interval (in days) after which modules are rotated.	0...30	1	Days	I	Cascade
M2	149	First Module to Start	Establishes the number of the next module to be rotated (this value is automatically updated at each rotation).	1..16	1		I	Cascade
M2	86	PID P	Defines the proportional term to change the setpoint of the cascade module.	0...1275	50		0	Cascade
M2	87	PID I	Defines the integral term to change the setpoint of the cascade module.	0...1275	500		0	Cascade
M2	150	PID Slew Rate Up	Defines the speed (in °C/100 ms) with which the setpoint of individual modules is increased in the event the primary circuit's set-point is not achieved (if the value is set to zero, the change is controlled by the PI of Par. 86 and 87 without restrictions).	0...25.5	1		0	Cascade
M2	151	PID Slew Rate Dn	Defines the speed (in °C/100 ms) with which the setpoint of individual modules is decreased in the event the primary circuit's set-point is exceeded (if the value is set to zero, the change is controlled by the PI of Par. 86 and 87 without restrictions).	0...25.5	1		0	Cascade
M2	152	PwrMode2 Min Power	Defines the power value (in percentage terms) against which the average power of all on modules in cascade operation mode must be compared (Par. 148 = 2).	0...100	20	%	I	Cascade
M2	153	PwrMode2 Hysteresis	Defines the extra power value (in percentage terms) compared to the average power of all on modules in cascade operation mode (Par. 148 = 2).	0...100	40	%	I	Cascade
M2	154	Post-Pump Period	Defines overrun time in seconds at the end of the cascade heat demand.	0...255	60	Sec.	I	Cascade

Menu	Par. No.	Display visualisation	Description	Range	Factory setting	UM	Access type	Category
M1	155	Frost Protection	This defines the temperature (detected by the primary sensor) below which the module pump and the system pump (with cascade configuration) are activated. If the temperature of the primary sensor falls below the value set by Par. 155 by another five degrees, then a request is generated that turns on the cascade. When the temperature of the primary sensor reaches the value defined by Par.155 increased by 5 degrees, then the request ceases and the cascade returns to stand-by mode.	10...30	15	°C	I	General
M2	184	N. active burner in DHW	With this setting it is possible to set the number of burners that are used for cascade DHW.	0...16	16		I	Cascade
M2	205	Dep. Zone Control	Enables the control of the additional heating zone managed by the Dependent module. 0 = Disabled 1 = Enabled	0...1	0		U	General
M3	73	Boiler Address	Defines the way in which the boiler is managed.	Managing, Stand-alone, Dependent	Stand-alone		I	Cascade
M3	156	Permit Emergency Mode	Enable/disable emergency mode.	Yes/No	Yes		U	Cascade
M3	157	Emergency Set-point	Defines the emergency mode setpoint.	20...90	70	°C	I	Cascade
M3	158	Delay Per Start Next Blr.	Defines the waiting time in seconds for the next cascade to start up in normal start mode.	0...1275	1275	Sec.	I	Cascade
M3	159	Delay Per Stop Next Blr.	Defines the waiting time in seconds for the last switched-on cascade to switch off in normal off mode.	0...1275	1275	Sec.	I	Cascade
M3	160	Delay Quick Start Next	Defines the waiting time in seconds for the next cascade to start up in quick start mode.	0...1275	400	Sec.	I	Cascade
M3	161	Delay Quick Stop Next	Defines the waiting time in seconds for the last switched-on cascade to switch off in quick off mode.	0...1275	240	Sec.	I	Cascade
M3	162	Hyst. Down Start Boiler	"reserved"	0...40	5	°C	I	Cascade
M3	163	Hyst. Up Stop Boiler	"reserved"	0...40	2	°C	I	Cascade
M3	164	Hyst. Down Quick Start	"reserved"	0...40	10	°C	I	Cascade
M3	165	Hyst. Up Quick Stop	"reserved"	0...40	4	°C	I	Cascade
M3	166	Hyst. Up Stop All	"reserved"	0...60	8	°C	I	Cascade
M3	167	Number of boilers	Defines the number of boilers connected (cascade of cascades).	1...16 (basic cascade) 1...8 (full cascade)	1		I	Cascade
M3	168	Power Mode	"reserved"	0 = Disabled 2 = Max burners 3 = Balanced burners	2		I	Cascade

Menu	Par. No.	Display visualisation	Description	Range	Factory setting	UM	Access type	Category
M3	169	Max. Setp. Offset Down	Defines the maximum decrease in the primary circuit's cascade set-point. Is based on the secondary circuit's probe reading.	0...40	2	°C	I	Cascade
M3	170	Max. Setp. Offset Up	Defines the maximum increase in the primary circuit's cascade set-point. Is based on the secondary circuit's probe reading.	0...40	5	°C	I	Cascade
M3	171	Start Mod. Delay Fact.	Defines the time in minutes from the moment the request is triggered until the activation of the set-point increases or decreases provided for by Par.169 e 170.	0...60	40	Min.	I	Cascade
M3	172	Next Boiler Start Rate	"reserved"	10...100	80	%	I	Cascade
M3	173	Next Boiler Stop Rate	"reserved"	10...100	25	%	I	Cascade
M3	174	Module Rotation Interval	"reserved"	0...30	5	Days	I	Cascade
M3	175	First Boiler to Start	"reserved"	1...8	-		I	Cascade
M3	176	PID P	Defines the proportional term to change the set-point of the cascade module based on the secondary circuit's temperature.	0...1275	25		0	Cascade
M3	177	PID I	Defines the integral term to change the set-point of the cascade module based on the secondary circuit's temperature.	0...1275	1000		0	Cascade
M3	178	PID Slew Rate Up	Defines the speed (in °C/100 ms) with which the set-point of individual modules is increased in the event the secondary circuit's set-point not reached (if the value is set to zero, the change is controlled by the PI of Par. 176 and 177 without restrictions).	0...25.5	1		0	Cascade
M3	179	PID Slew Rate Dn	Defines the speed (in °C/100 ms) with which the set-point of individual modules is decreased in the event the primary circuit's set-point is exceeded (if the value is set to zero, the change is controlled by the PI of Par. 176 and 177 without restrictions).	0...25.5	1		0	Cascade
M3	180	PwrMode2 Min Power	"reserved"	0...100	20	%	I	Cascade
M3	181	Pwr-Mode2 Hysteresis	"reserved"	0...100	40	%	I	Cascade
M3	182	Post-Pump period	"reserved"	0...255	30	Sec.	I	Cascade

## 6.2 Setting the main parameters

Some parameters are essential in order for the system to operate in cascade and setting these parameters is a determining factor for correct system operation.

### 6.2.1 Par.189 – module address (burner)

Parameter 189 sets the address with which the module (burner) is recognised and enables the primary sensor (SS).

Three values can be set:

- **Managing:** to be set on the Managing module so that primary sensor operation is activated.
- N.B. Refer to the specific diagram to connect the sensor
- **Stand Alone:** to be set on the Managing module so that primary sensor operation is deactivated;
  - $2 \div 7$  to be set on all Dependent modules.

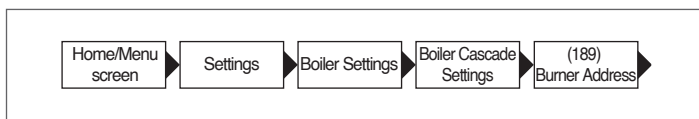

### 6.2.2 Par.147 – no. of modules (burners)

Parameter 147 is for setting the number of connected modules (burners). This parameter must only be set on the Managing module.

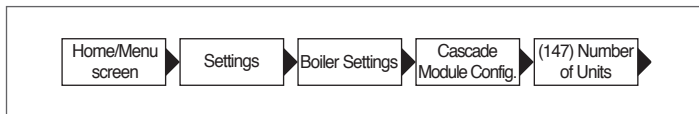

### 6.2.3 Par.73 – Boiler address (cabinet)

Parameter 73 sets the address with which the boiler (cabinet) is recognised and enables the secondary sensor (SC).

Three values can be set:

- **Managing:** to be set on the Managing module so that secondary sensor operation is activated.
- N.B. Refer to the specific diagram to connect the sensor
- **Stand Alone:** to be set on the Managing module so that secondary sensor operation is deactivated;
  - $2 \div 7$  to be set on all Dependent modules.

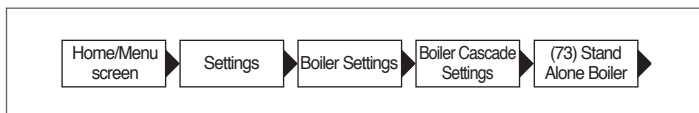

## 6.3 Par.167 – no. of boilers (cabinets)

Parameter 167 sets the number of connected boilers (cabinets). This parameter must only be set on the Managing boiler.

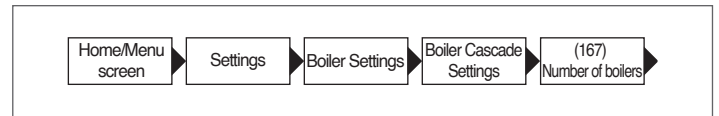

### 6.3.1 Par.7 – heating setpoint hysteresis

The parameter 7 adjust shutdown of the individual modules when the setpoint is exceeded. With cascade operation, this value must be increased (up to a maximum of 20°C) to prevent module operation from being disabled (since the default value is 5°C) if the system decides to increase the setpoint based on the value read on the primary or secondary sensor (see explanation in paragraphs "General operation", "Operation with the primary sensor" and "Operation with the secondary sensor") This parameter is to be modified (in the same way) on all modules of the cascade (Managing module and all the relative Dependent modules).

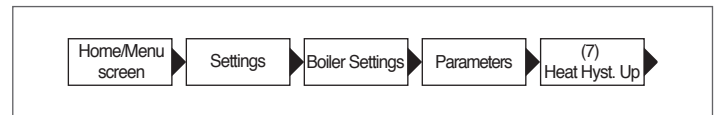

### 6.3.2 Par.97 – definition of the system with circulator / system with two-way valve

The parameter 97 serves to quickly configure the inputs and outputs on the board of each module in order to adapt operation if a circulator is present or if a two-way valve is present. This parameter must be configured correctly on both the Dependent modules and the Managing module.

Parameter 97 must be set to 1 if system 1 or 2 is being used (characterised by the use of the module pump), while it must be set to 2 if system 3 or 4 is being used (characterised by the use of the two-way valve).

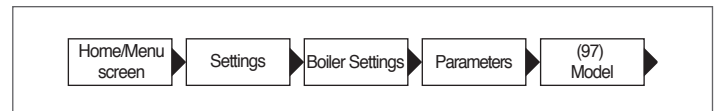

## 6.4 Parameter 148: operating mode of the cascade

It is possible to adopt cascade management which can be modified according to different strategies. These different strategies can be set using the parameter known as "Cascade mode" Par. 148.

### 6.4.1 Par 148 = 0

The start-up/shutdown law of each module is based on the following graph.

The shut-off values of the lines with the y axis are the sum or the difference of the values of the corresponding parameter in relation to the value of the setpoint sent by the Managing module to the modules.

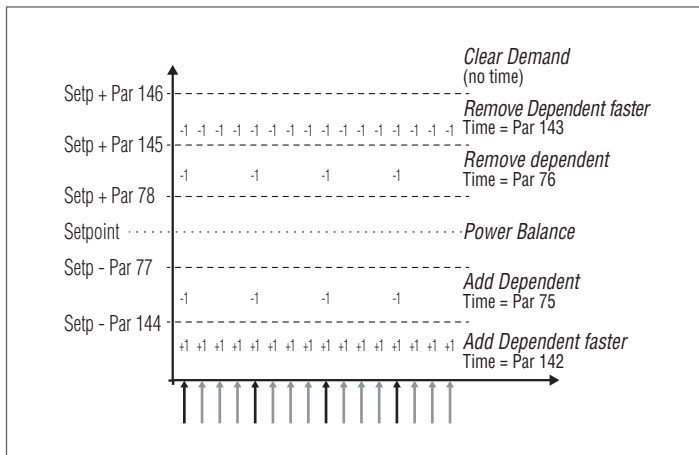

Six bands are defined on the basis of the temperature read (by the Managing module) on the delivery manifold of the primary system.

- In the central band **Power balance**, defined (by the variable parameters) around a setpoint, no start-ups or shutdowns of the Dependent modules are envisaged. The parameters which define this band are 77 and 78.
- In the band **Remove dependent** and **Add dependent**, the start-ups and shutdowns are carried out with "long" time intervals which can differ between start-up and shutdown. The parameters which define this band are 77, 78, 144, 145. The time interval is defined by parameters 75 and 76.
- In the band **Remove dependent Faster** and **Add dependent Faster**, start-ups and shutdowns are carried out with a "short" time interval which, even in this case, can differ between start-up and shutdown. The shutdown band is between the values of parameters 146 and 145, while the start-up band is below the value defined by parameter 144. The time range is defined by parameters 142 and 143.
- In the band **Clear demand**, all the modules are immediately stopped. This band is above the value defined by parameter 146.

### 6.4.2 Par 148 = 1

In this mode the system manages the cascade so that the minimum number of modules is on.

The first difference in relation to mode 0 refers to the logic with which the modulation of Dependent modules within the cascade is managed.

While each module modulates with its own PID in mode 0, no more than two dependent modules modulate with the same criteria in mode 1, while the remaining modules operate at maximum power. The diagram is represented in the following figure:

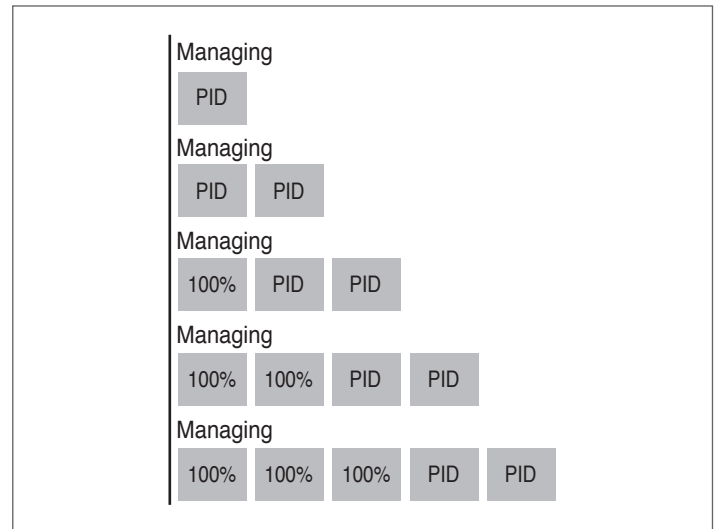

Practically speaking, if more than two modules are on, only two modules are controlled via PID, while the others receive a signal to move to maximum power.

The second difference refers to the start-up/shutdown rules of the individual modules.

In any case, the start-up and shutdown rules are managed according to the indications shown in the previous graph. The difference is that it is also possible to have start-ups/shutdowns of the Dependent modules in the "balancing" zone.

This additional start-up criteria (valid in the balancing band only) ensures that a module is started-up when any one of the two modules controlled by a PID adjustment has reached a threshold power (Par 82) once a specific wait time defined by Par 75 has elapsed.

Similarly (still within the balancing band), a module is shutdown if both modules controlled by a PID adjustment have reached a percentage of power which is below the minimum power threshold (Par 83) once a specific wait time defined by Par 75 has elapsed.

### 6.4.3 Par 148 = 2

---

In this mode the system manages the cascade so that the maximum number of modules is on.

This mode is similar to mode 0 apart from the start-up and shutdown rules.

In this case the rules based on the information illustrated by the previous graph are still valid, with the following differences (in any case, always applicable to the "balancing" band only):

To add an additional dependent module, the managing module evaluates whether the sum of the power (calculated on the basis of the fan speed) of all the active modules is greater than the product between the number of the active dependent modules increased by one and the minimum power value (Par 152) increased by a hysteresis value (defined by Par 153).  $[\sum(P_1, P_2, \dots, P_n) > (n+1) * (\text{Par } 152) + (\text{Par } 153)]$ .

To shutdown a dependent access, the managing module evaluates whether the sum of the power (calculated on the basis of the fan speed) of all the active modules is less than the product between the number of the active dependent modules and the minimum power value (Par 152).  $[\sum(P_1, P_2, \dots, P_n) < (n) * (\text{Par } 152)]$ .

 We must consider that the percentage of power varies from a minimum of 1% and a maximum of 100% and therefore, the parameter values 152 and 153 are not to be taken as the percentage of absolute power.

## APPENDIX

## I SETTING PARAMETERS OF THE ADDITIONAL ZONE

Controls interface

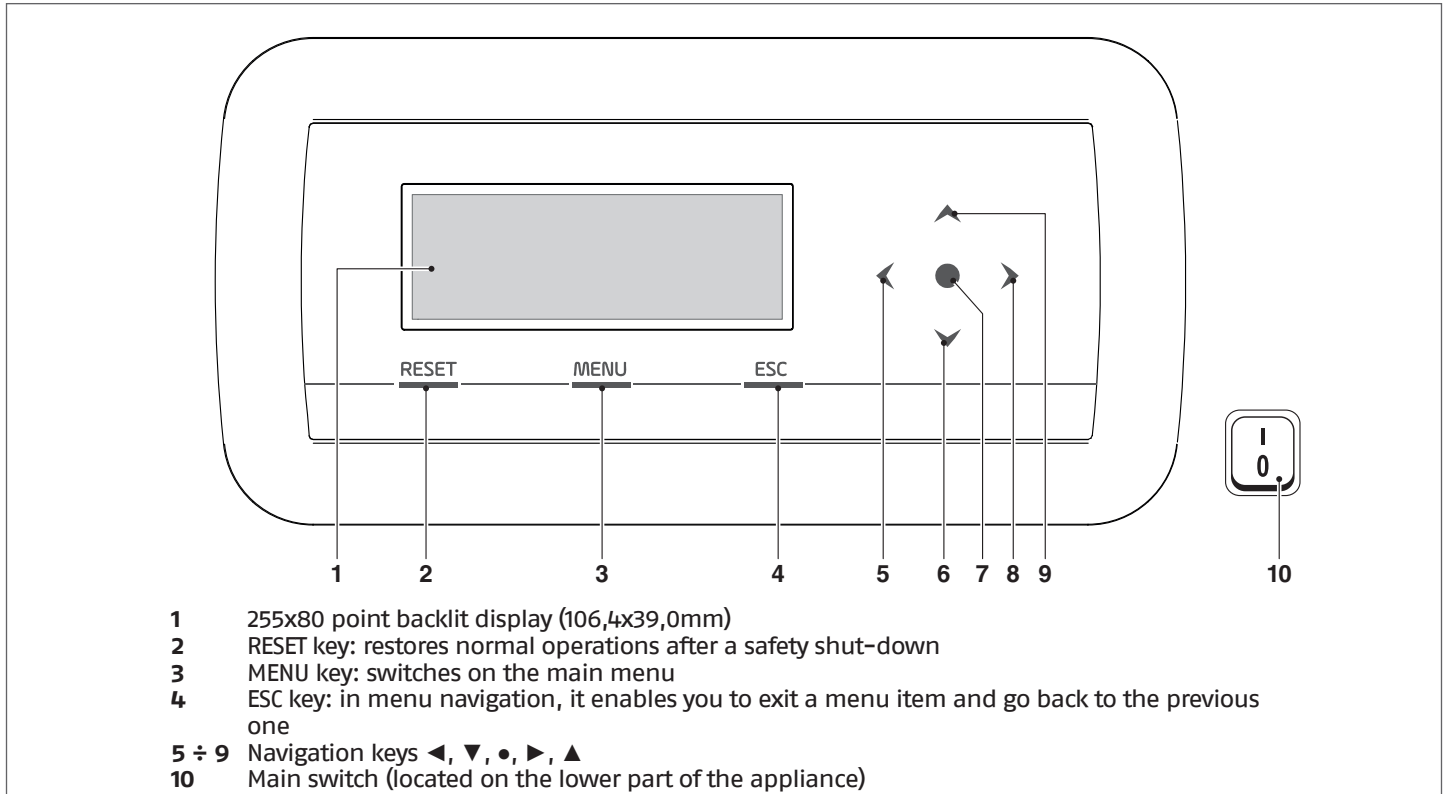

## I.1 Setting zone parameters (accessible only with installer password)

Menu → "Settings" → "Zone Config."

This menu allows you to separately set the parameters of all the connected zones with the exception of the "Extra setpoint zone" which is the same for all zones.

To select the zone for controlling/changing the parameters, proceed as follows:

- press the ▶ key so that the number to the right of "zone" is highlighted;
- once the number is highlighted use the ▲ and ▼ keys to change the number of the zone;
- once the zone is selected, confirm with the ● key.

The zone parameters are the following:

Description	Standard value that is set	Range	Explanation	UM
Post-circ. Zone Pump	120	0-255	Establishes the time in seconds of the post-circulation	Secs
Mix Valve Max Op/Cl Time	25	0-255	Fixes the time in second of the total opening/closing of the mix valve (valid for three point mix valve)	Secs
Mix Valve Max steps	700	0-65535	Fixes the number of steps for the total opening of the mix valve (valid for step-by-step mix valve)	
PID zone mode	Symmetrical	Symmetrical/Asymmetrical	Fixes the PID control mode	
PID P Zone	10	0-255	Proportional parameter for the valve control	
PID I Zone	150	0-255	integrative parameter for the valve control	
PID D Zone	0	0-255	Derivative parameter for the valve control	
Extra zone setpoint	10	0-30	Establishes the increase for the primary setpoint with respect to the zone setpoint	°C

**!** For more information on navigating the commands interface (module display), see paragraph "Electronic control" of the instruction booklet of the individual appliance **Condexa PRO**.

I.I.I Menu structure

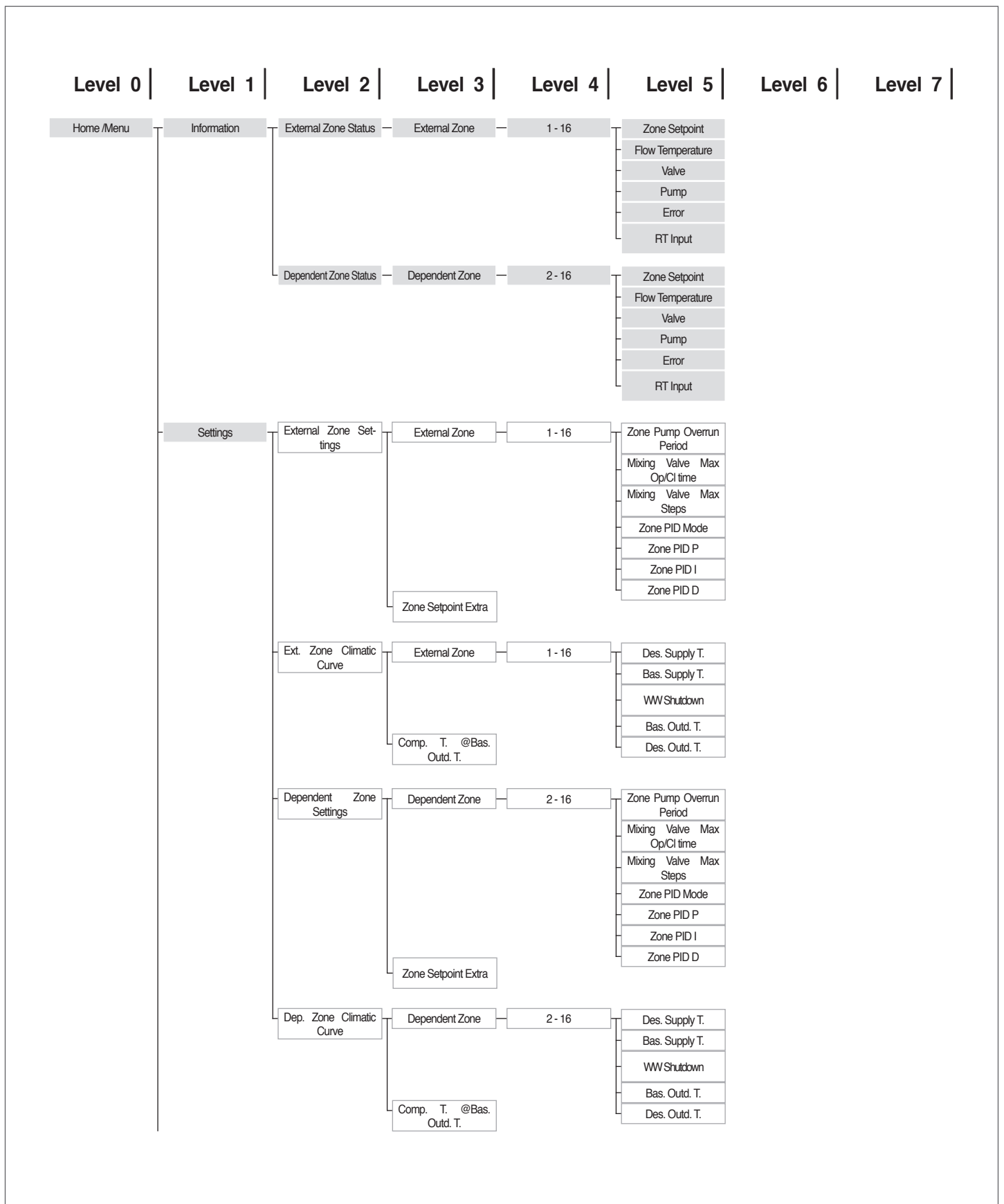

Level 0 | Level 1 | Level 2 | Level 3 | Level 4 | Level 5 | Level 6 | Level 7 |

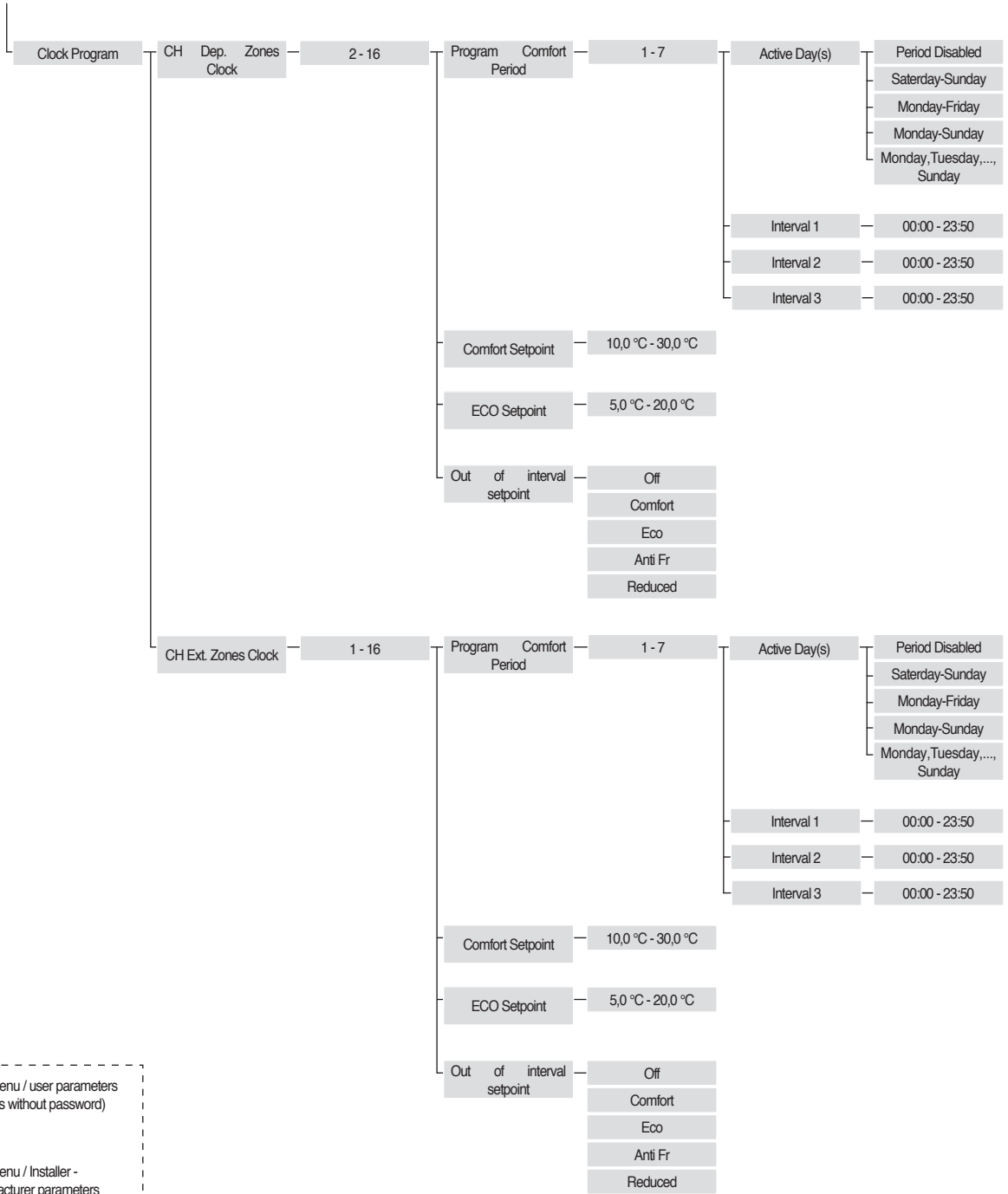

Sub-menu / user parameters  
 (access without password)

Sub-menu / Installer -  
 Manufacturer parameters  
 (access with password)

## I.II Setting zone's climatic curve parameters (accessible only with installer password)

Menu → "Settings" → "Zone Clim. Curve"

- press the ► key so that the number is highlighted on the right of the word "Zone";
- use the ▲ and ▼ keys to change the zone number;
- press the ● key.

The following is displayed:

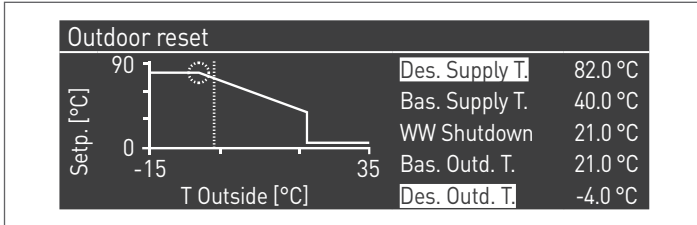

The "Comp. T. @ T.ext. Max" parameter, if other than 0, transforms the climatic curve from linear to quadratic allowing you to best adapt the variation of the setpoint to the variation of the outdoor temperature.

The resulting quadratic climatic curve will have three parameters:

- Heat. Set. Max
- Baseline Outdoor Temp.
- Text. Min

of the basic linear climatic curve and a value of the Heat. Set. Min. diminished by the value of the parameter "Comp. T. @ T.ext. Max", as can be seen in the example in the figure.

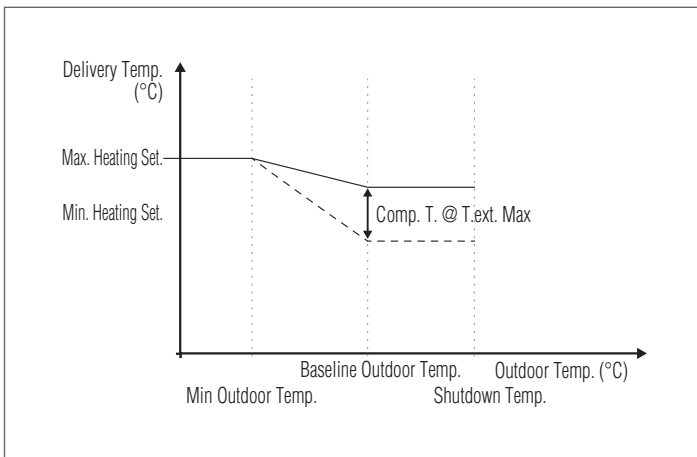

## I.III Programming the zone

By default the schedule timer is disabled.

To start a request from the zone, simply close the contact of the zone request. In this case the module (or the cascade of modules) will start with a setpoint equal to the value calculated on the zone climatic curve increased by the "Zone Extra Setpoint" value and the mix valve will modulate to maintain the delivery temperature of the zone at the calculated setpoint.

To activate zone programming:

Menu → "Settings" → "Clock Settings"

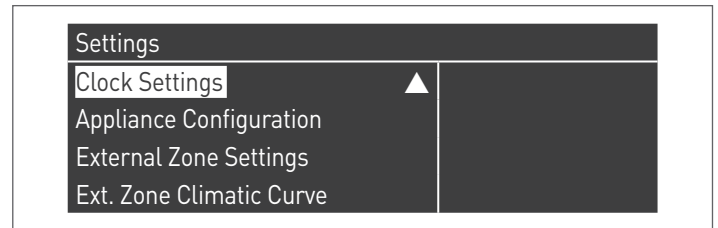

Confirming with ● the following screen is displayed:

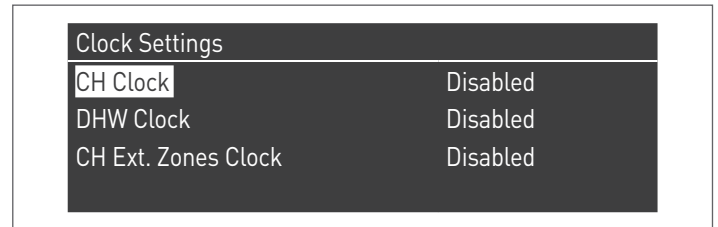

- with the ▲ / ▼ keys select "CH Zones clock"
- with the ► key move to "Disabled", change it to "Enabled" with the ▲ / ▼ keys
- confirm with the ● key

Go to:

Menu → "Clock program"

Confirming with the ● key:

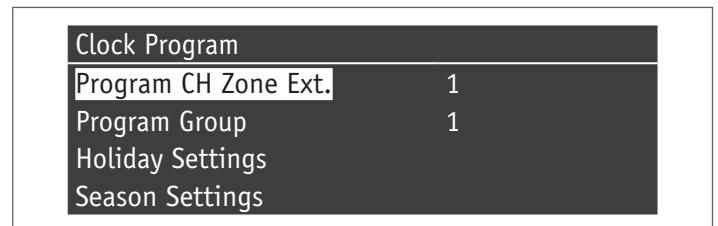

At this point select the number of the zone to be programmed and confirm with the ● key.

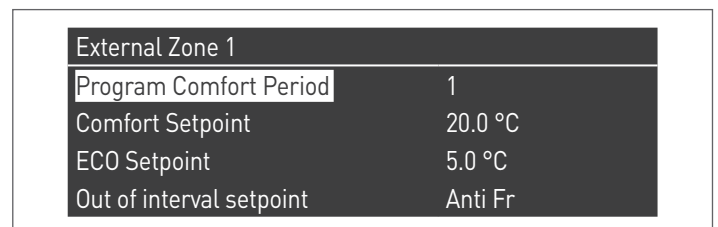

The programmable periods for each zone are 7 and they can be selected by changing the number that appears beside "Program Comfort period".

The "Comfort Setpoint" is the setpoint that is set for the area served by the zone in the active time band established within the period and can be set between ten and forty degrees. Setting the "Comfort Setpoint" at a default of 20°C, the climatic curve that regulates the setpoint of the zone is exactly that which was set in paragraph Setting zone's climatic curve parameters (accessible only with installer password) on page 88.

By changing the "Comfort Setpoint" the climatic curve is moved upwards or downwards. Dependent on whether the setpoint is higher or lower than 20°C. The curve will shift by two degrees for each degree of difference between the value of the setpoint and the value 20.

The "ECO Setpoint" is a setpoint that can be set between 5 and 20 degrees and can be selected as a setpoint for the area served by the zone outside the active time band.

The "Out of the interval Setpoint" defines how the zone outside the active time bands are managed (within which the setpoint of the area is always set on "comfort").

The selections for the "Out of the interval Setpoint" are the following:

- **Eco:** the ambient setpoint is set to ECO. The zone setpoint is changed by two degrees less for each degree of difference between the ECO setpoint and the value 20 (for example, if at 20° I have a setpoint of 50, at 18 degrees I have a setpoint of  $50+2*(18-20)=46$ ).
- **Night-time:** the zone setpoint is lowered by 10 degrees with respect to the value of the zone setpoint set for a  $T_{comfort} = 20^\circ$ .
- **Antifreeze:** the ambient setpoint is set at 5°C, thereby obtaining a reduction with respect to the comfort setpoint of 30 degrees.
- **Off:** in this case the delivery of heat is interrupted.
- **Comfort:** the setpoint remains the same as that for the active time bands. This choice clearly makes no sense when scheduling is desired, but it can be useful if you want to provide heat continuously without changing the programming itself.

 So that the zone programming works the "heat request" contact should be closed. Otherwise the zone will ignore any request from the schedule timer.

## I.IV Scheduling the time bands

By going to:

Menu → "Clock program" → "Zones CH Program "

External Zone 1	
Program Comfort Period	1
Comfort Setpoint	20.0 °C
ECO Setpoint	5.0 °C
Out of interval setpoint	Anti Fr

Entering in "Program Comfort Period":

External Zone 1 - Period 1		
Active Day(s)	Monday-Sunday	
Interval 1	07:10	11:00
Interval 2	00:00	00:00
Interval 3	00:00	00:00

Using the option "Active Day(s)" it is possible to select the scheduling period. You can select a day of the week or else one of these three groups of days:

- Mon-Sun
- Mon-Fri
- Sat-Sun

This facilitates weekly scheduling or else scheduling that is different during the work week and the week-end.

There are three active time bands for each period. The time resolution is 10 minutes.

## I.V Information on the operation of the zone

By going to:

Menu → "Information" → "Zone Status"

External Zone Status 1	
External Zone	1

To choose the zone whose information will be displayed, proceed in the same way as in the previous paragraph.

Once the ● key is selected the following display appears:

External Zone 1	
Error	▲ 255
RT Input	No
Zone Setpoint	-10.0 °C
Flow Temperature	25.5 °C

External Zone 1	
Zone Setpoint	▲ -10.0 °C
Flow Temperature	25.5 °C
Valve	0%
Pump	Off



A series of horizontal dashed lines spanning the width of the page, providing a template for handwriting practice.

# RIELLO

RIELLO S.p.A.  
Via Ing. Pilade Riello, 7  
37045 - Legnago (VR)  
[www.riello.com](http://www.riello.com)

The manufacturer strives to continuously improve all products. Appearance, dimensions, technical specifications, standard equipment and accessories are therefore liable to modification without notice.