



# TAU Unit 35

EN USER MANUAL

# RIELLO

Dear Customer,

Thank you for preferring a **RIELLO** heating unit, a modern, high-quality product that is able to guarantee your maximum well-being for a long period of time, with high levels of reliability and safety. In particular, if working together with a Technical Assistance Service **RIELLO** that is specifically prepared and trained to perform periodic maintenance, your unit will remain at maximum efficiency levels at minimum operating costs and if required, replacements with original spare parts can be made. This instruction manual contains important instructions and precautions that must be observed to ensure the trouble-free installation and efficient functioning of your **TAU Unit** boiler.

Please accept our renewed thanks for your purchase  
Riello S.p.A.

## CONFORMITY

---

**TAU Unit** boilers conform to the following directives:

- Regulation (EU) 2016/426
- Directive 92/42/EEC on efficiency requirements
- Electromagnetic Compatibility Directive 2014/30/EU
- Ecodesign Directive 2009/125/CE for energy-related products
- Regulation (EU) 2017/1369 Energy labelling
- Low Voltage Directive 2014/35/EU
- Delegated Regulation (EU) N. 811/2013
- Delegated Regulation (EU) N. 813/2013.



**At the end of its life, the product should be not be disposed of as solid urban waste, but rather it should be handed over to a differentiated waste collection centre.**

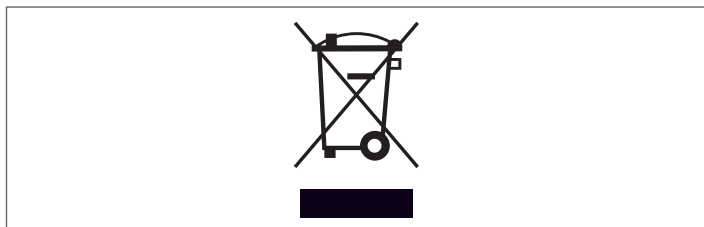

# CONTENTS

---

<b>1 GENERAL INFORMATION</b>	<b>4</b>
1.1 General Safety Information	4
1.2 Precautions	4
1.3 Description of the appliance	5
1.4 Safety and control devices	5
1.5 Control panel	6
1.6 Electronic control	7
1.6.1 Menu structure	8
1.6.2 Parameters' list	13
<b>2 USE</b>	<b>14</b>
2.1 Putting into service	14
2.2 Switching the appliance on and off	15
2.3 Ignition failure	15
2.4 Date and time setting	15
2.5 Adjustment of heating setpoint	16
2.6 Adjustment of domestic setpoint	17
2.7 Scheduled programme	17
2.8 Temporary or short-term shut-down	20
2.9 Preparing for extended periods of disuse	20
2.9.1 System filling and emptying	21
2.9.2 CH frost protection	21
2.10 Cleaning	21
2.11 "Service reminder" function	22
2.12 Maintenance	22
2.13 Error List	22
2.14 Troubleshooting	23
2.15 Useful information	24
<b>3 RECYCLING AND DISPOSAL</b>	<b>25</b>













The following symbols are used in this manual:

 **CAUTION!** = Identifies actions that require caution and adequate preparation.

 **STOP!** = Identifies actions that you MUST NOT do.











## 1 GENERAL INFORMATION

### 1.1 General Safety Information

-  After removing the packaging, check the condition and completeness of the supply. If there are any problems, contact the company **RIELLO** that sold the equipment.
-  This product must be installed by a legally qualified heating engineer. On completion of the installation, the installer must issue the owner with a declaration of conformity confirming that the installation has been completed to the highest standards in compliance with the instructions provided by **RIELLO** in this instruction manual, and that it conforms to all applicable laws and standards.
-  This product must only be used for the purpose for which it is designed and made, as specified by **RIELLO**. **RIELLO** declines all responsibility, contractual or other, for damage to property or injury to persons or animals caused by improper installation, adjustment, maintenance or use.
-  The room where the boiler is installed must be properly ventilated to ensure a sufficient supply of air for correct combustion.
-  In case of water leaks disconnect the equipment from the power mains, close the water supply and promptly alert Technical Assistance Service **RIELLO** or professionally qualified personnel.
-  Regularly check that the condensate drain is free from obstruction.
-  Periodically check that operating pressure in the water circuit is over 1 bar but below the maximum limit specified for the boiler. If this is not the case, contact Technical Assistance Service **RIELLO** or a professionally qualified heating engineer.
-  Long periods of inactivity of the equipment imply the following operations to be carried out:
  - Set the main switch of the equipment to "0"
  - Set the main switch of the system to "OFF"
  - Close the fuel valves and the water valves of the thermal system
  - Drain the central heating circuit if there is any risk of freezing.
-  The product must be serviced at least once a year. Servicing must be arranged in advance with the **RIELLO** Technical Assistance Service.
-  This manual is an integral part of the appliance and must therefore be kept with care and must ALWAYS accompany the boiler, even when it is passed on to another owner or user or transferred to another installation. If it is lost or damaged, please contact your local Technical Assistance Service **RIELLO** for a new copy.
-  This manual must be read carefully so as to ensure the correct and safe installation, operation and maintenance of the appliance. The Owner must be adequately informed and trained on how to operate the appliance. Make sure that he/she is familiar with all the information required for safe system operation.
-  We recommend cleaning inside the exchanger once a year, extracting jet and burner and removing any installation debris by suction. This operation should be done by personnel from the Technical Assistance Service only.

### 1.2 Precautions

The operation of any appliance that uses fuel, electrical power and water demands that a number of fundamental safety precautions be respected:

-  Do not allow children or infirm persons to operate the system unsupervised.
-  It is forbidden to use electrical devices or equipment, such as switches, appliances, etc. if there is a smell of gas or unburnt products. If so:
  - Ventilate the room, opening doors and windows
  - Close the fuel shut-off cock
  - Report the fault immediately to the **RIELLO's** Technical Assistance Service or a professionally qualified heating engineer.
-  Do not touch the boiler while barefoot or wet.
-  Do not plug or block the condensate drain outlet.
-  Never pull, disconnect, or twist the electrical cables coming from the appliance even if it is disconnected from the mains electricity supply.
-  Do not obstruct or restrict the vents in the room where the boiler is installed. Adequate ventilation is essential for correct combustion.
-  Do not expose the boiler to the elements. It is not designed for use outdoors.
-  Do not switch off the appliance if the outdoor temperature may drop to below ZERO (frost hazard).
-  Do not leave flammable containers and substances in the room where the device is installed.
-  It is forbidden to activate the equipment without water.
-  The equipment casing must not be removed by people without specific qualification and expertise.

### 1.3 Description of the appliance

The condensing thermal unit **TAU Unit** is a hot water generator, with high thermal efficiency, for the heating of environments and production of domestic hot water (DHW) coupled to an external heater.

The boiler body is in high alloy stainless steel and develops vertically ensuring maximum duration and reliability, meeting at the same time the most stringent national and European regulations on the emission of heavy metals in condensate drain waters.

The double return hydraulic circuit (high or low temperature) favours temperature stratification inside the body and optimises the performance.

The boiler body is covered in high density glass wool insulation to reduce heat loss.

The pre-mixed microflame burner with power modulation ratio 1:10 ensures low polluting emissions (NO<sub>x</sub> and CO) in compliance with the most stringent European Regulations.

The thermoregulation with user interface and display in the control panel **TAU Unit** allows managing the safety and control devices in compliance with current regulation. By connecting the external probe it is possible to activate the climatic control function of the heating circuit, enhancing the seasonal energy recovery characteristics.

The thermoregulation adapts with flexibility to the different system needs; for example, it is possible to increase the number of heating circuits supplied with high and low temperature and connect the devices **TAU Unit** in cascade (see accessories Catalogue).

### 1.4 Safety and control devices

The thermal unit **TAU Unit** is equipped with the most advanced safety and regulation systems available on the market.

Each fault is signalled through a numeric error code displayed on the screen and stops the equipment causing the automatic closure of the gas valve.

The following are installed on the water circuit:

- **Safety thermostat:** on the body of the generator, it intervenes to stop the appliance if the temperature exceeds the threshold limit of 110°C.
- **Delivery temperature probe:** immersion probe on the delivery line of the generator is used by the regulator to view and check the delivery water temperature and check the correct switching on and off of the equipment based on the programmed setpoint. The regulator uses the same probe to stop the generator in case of overtemperature, before the triggering of the safety thermostat.
- **Return temperature probe:** the contact probe placed on the return line of the boiler is used by the regulator to view the return water temperature with which it calculates, together with the delivery temperature, the temperature difference between delivery and return ( $\Delta t$ ), which allows regulating the modulation of the thermal unit circulation pump in heating mode.

- **Flue gas thermostat:** placed in the lower part of the exchanger, it triggers with high flue gas temperature (>75°C).
- **Flue gas probe:** placed in the lower part of the exchanger, causes a temporary error if the temperature of the combustion products exceeds 85°C, and a permanent error if it exceeds 90°C.

Through specific inlets and outlets, the thermoregulation **TAU Unit** allows managing the following optional safety devices outside the equipment:

- **Pressure transducer or water minimum pressure switch:** the connection of one of the two optional devices, to be carried out by the installer, allows the thermoregulation to continuously view and check the pressure of the primary circuit to start or stop the equipment in case of low pressure.
- **LPG fuel shut-off solenoid valve:** the thermoregulation, via a programmable output, allows managing (based on the designated type of fuel and system) the fuel shut-off solenoid valve for LPG, installed outside the equipment by the installer.
- **Gas minimum pressure switch:** a specific outlet is present for the connection of the gas minimum pressure switch (optional) to be installed outside the equipment. The device will continuously check the correct inlet gas pressure to start or stop the equipment in case of low pressure.

 The triggering of the safety devices indicates a potentially dangerous malfunctioning of the equipment. Therefore, immediately contact the Technical Assistance Service.

 Safety devices must be replaced by Technical Assistance Service, using only original parts. Refer to the spare parts catalogue supplied with the appliance. After the repair perform an ignition test and check that the equipment works correctly.

 The appliance must not be put in service, even temporarily, when tampered safety devices are not in operation or have been tampered with.

## 1.5 Control panel

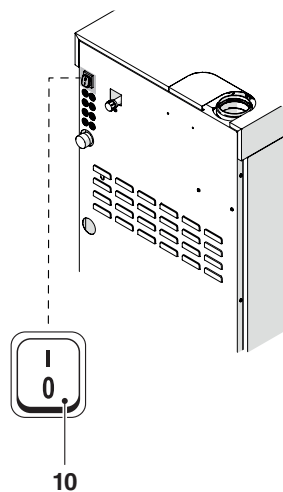

### CONTROL INTERFACE

- 1** 255x80 point backlit display (106,4x39,0mm)
- 2** RESET key: restores normal operations after a safety shut-down
- 3** MENU key: switches on the main menu
- 4** ESC key: in menu navigation, it enables you to exit a menu item and go back to the previous one
- 5 ÷ 9** Navigation keys ◀, ▼, ●, ▶, ▲
- 10** Main switch (placed on the rear panel of the equipment)

### DISPLAY VISUALISATION

- 11** Outside temperature
- 12** Setpoint
- 13** Clock

## 1.6 Electronic control

The electronic control operator interface menu is a multi-level one. Navigation between the various levels is shown in the figures below. Level 0 displays the Home Screen (Home). Level 1 displays the Main Menu screen. The subsequent levels are activated depending on available sub-menus.

Please note that the thermal module's operating parameters are identified with a number, whilst other additional functions are simply descriptive.

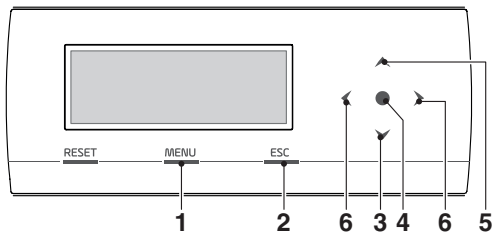

- 1 switches on the main menu
- 2 in menu navigation, it enables you to exit a menu item and go back to the previous one
- 3 supports selecting menus or parameters or decreasing numeric values
- 4 enter
- 5 supports selecting menus or parameters or increasing numeric values
- 6 supports moving to the RH/LH area of the display

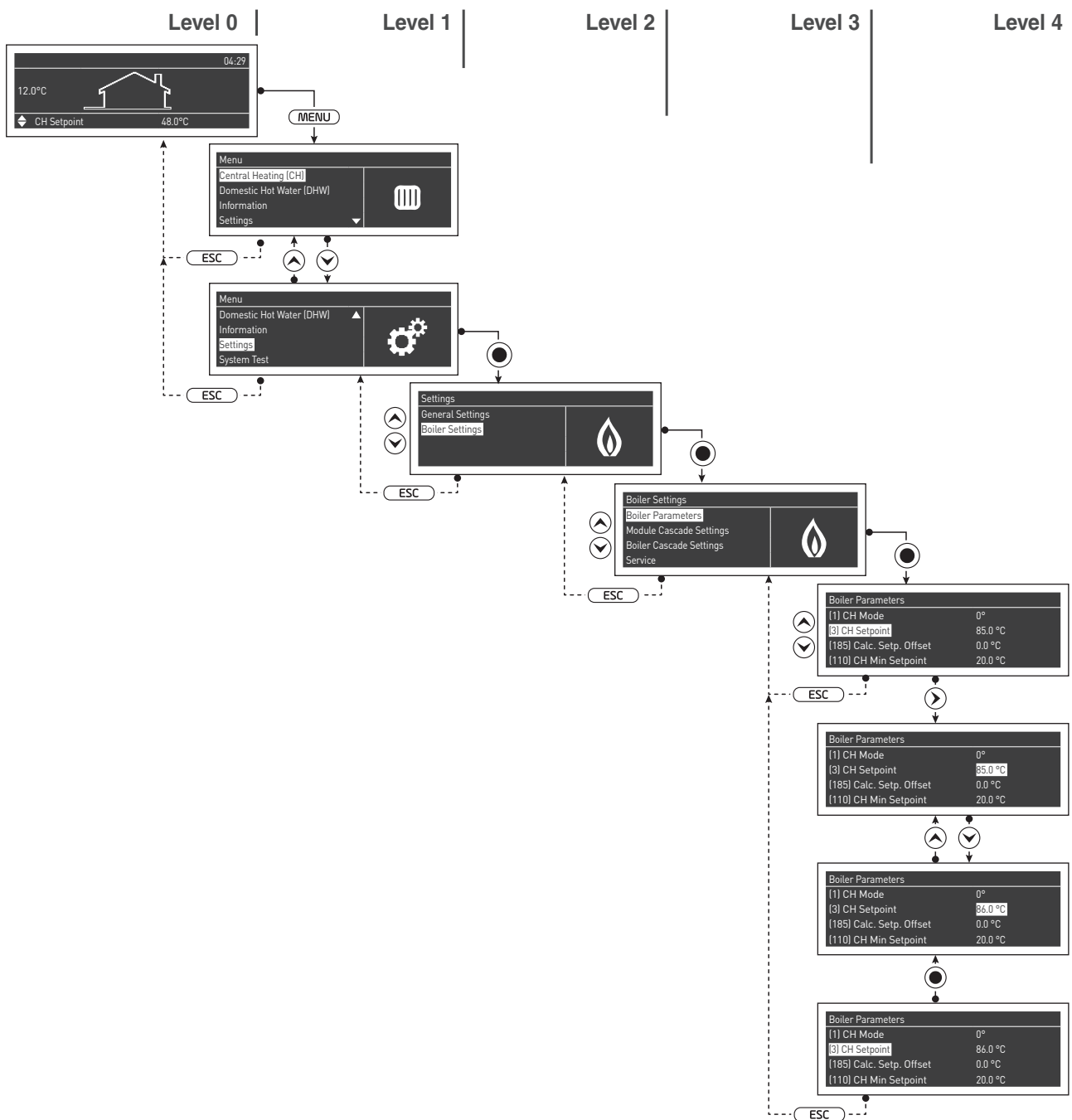

1.6.1 Menu structure

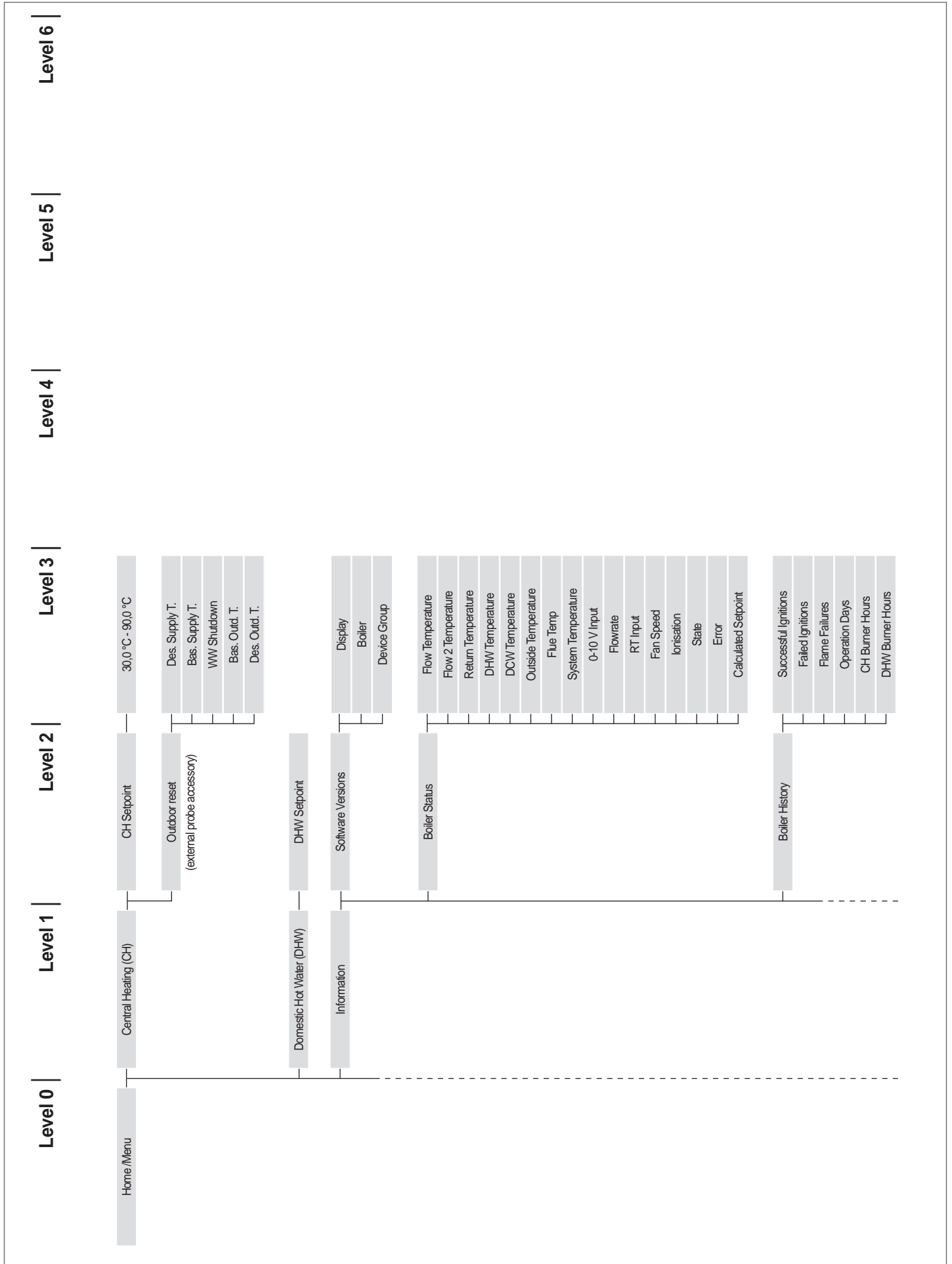

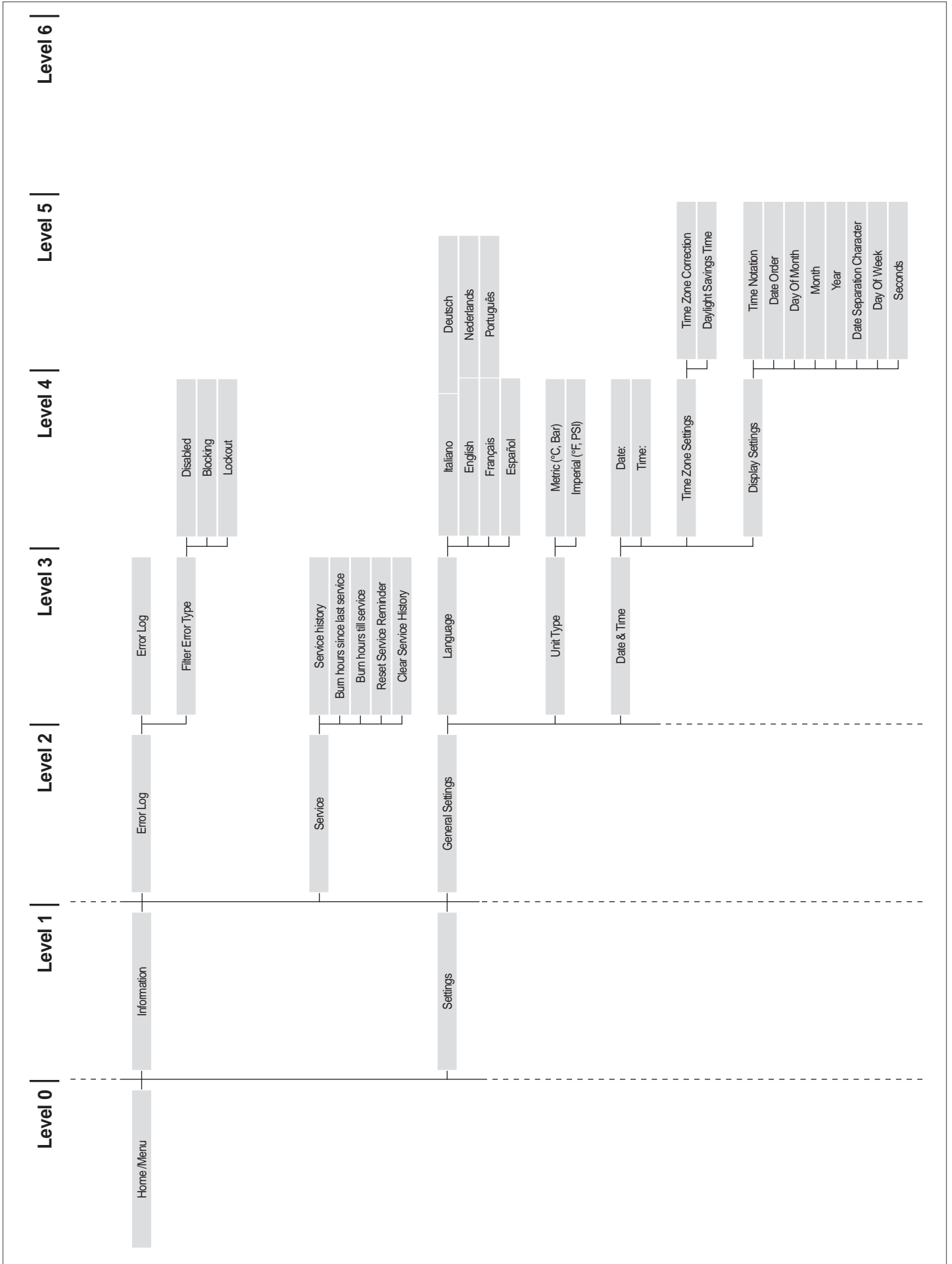

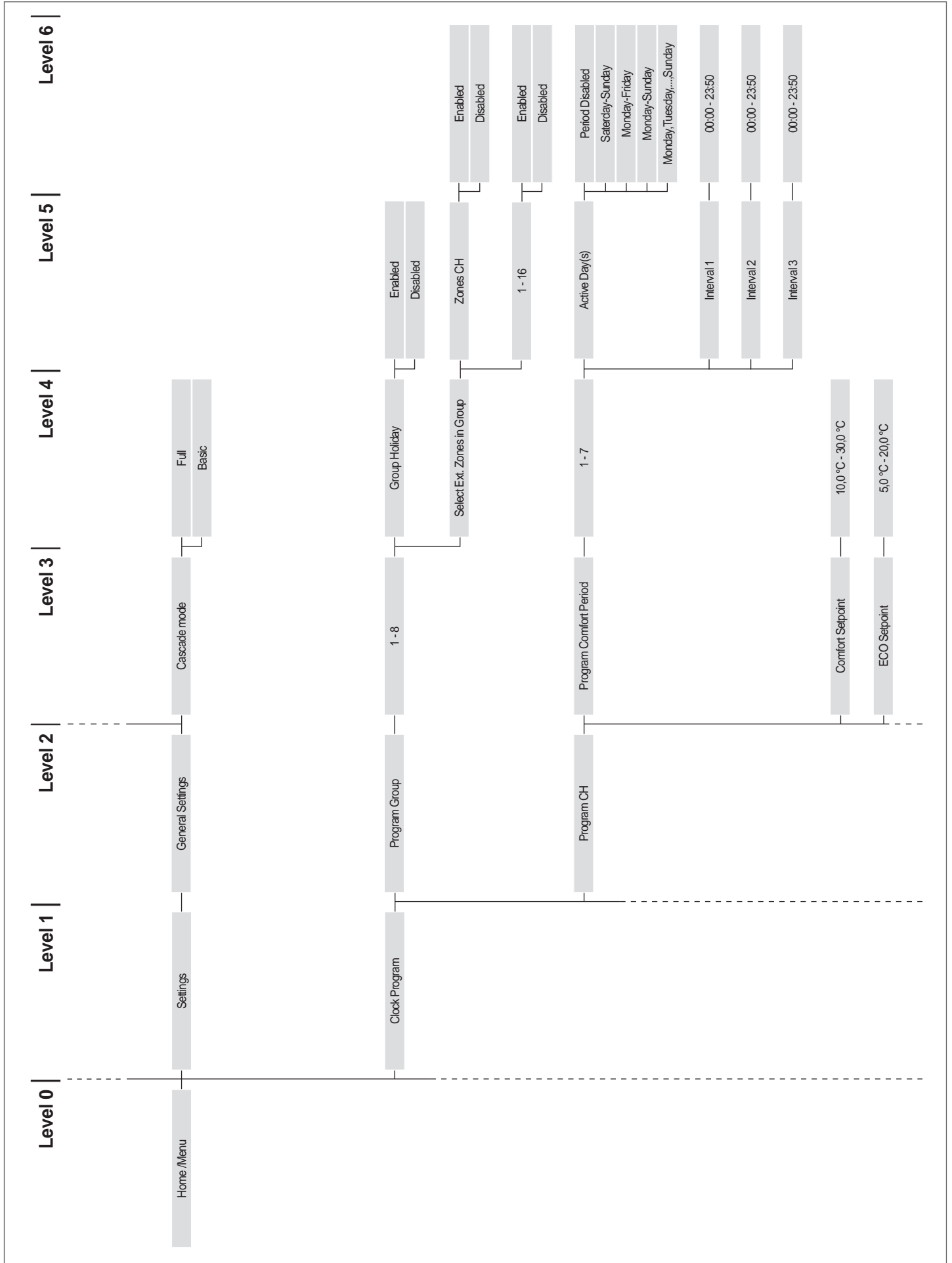

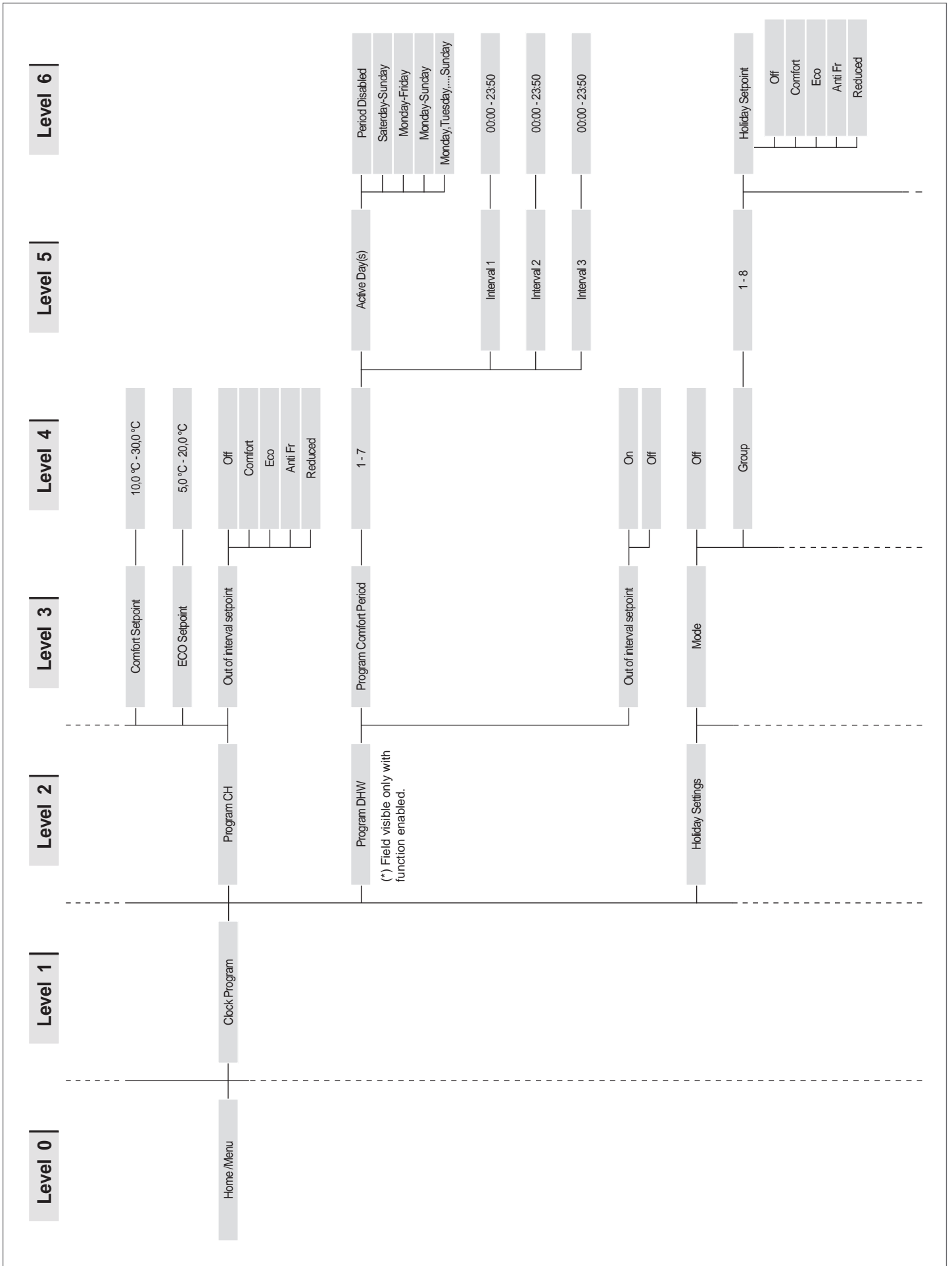

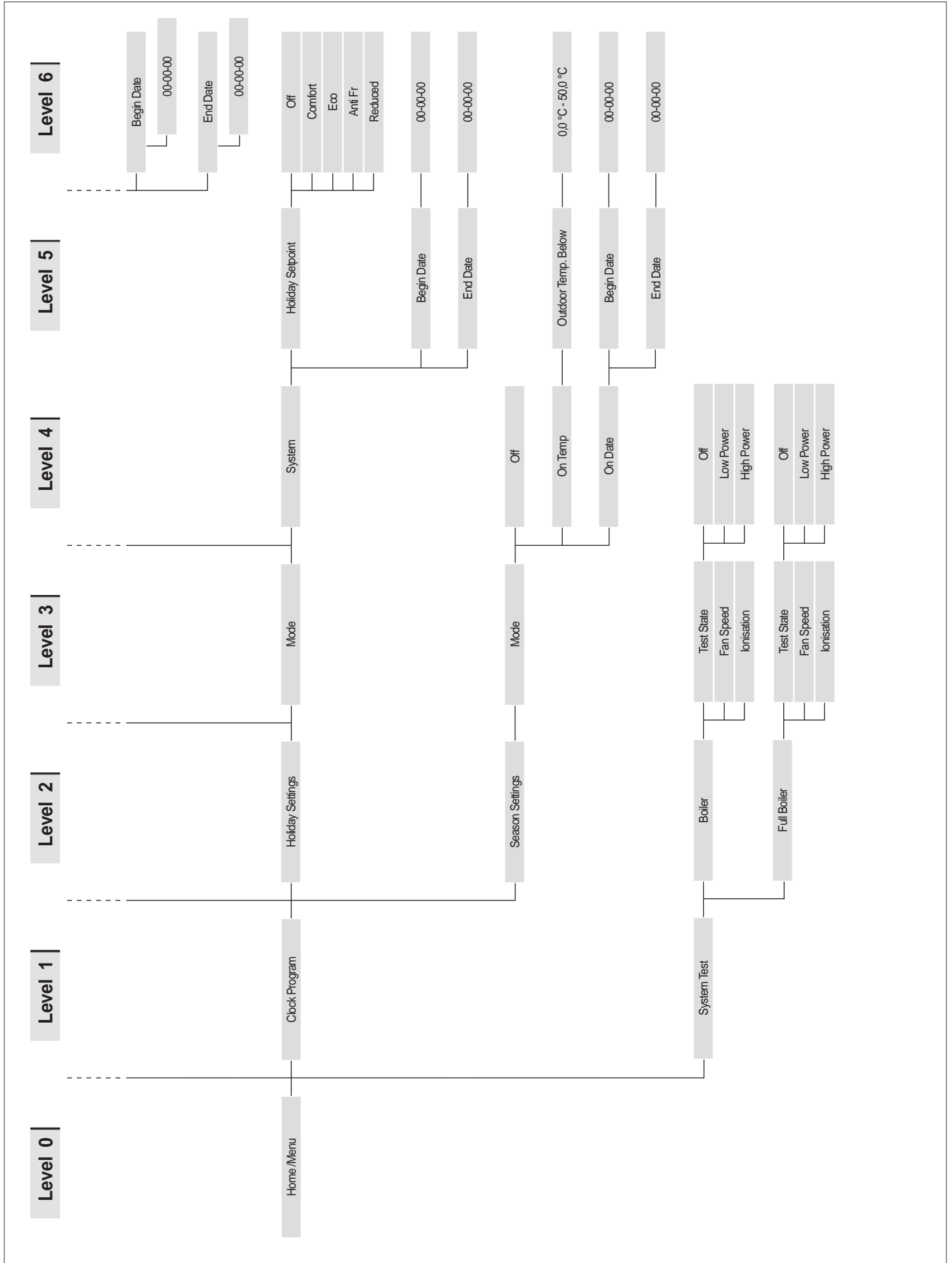



## 1.6.2 Parameters' list

 The programming lines can be hidden, according to the access level (User, Installer, Manufacturer) and to the thermal unit configuration.

 The parameters of the Installer and Manufacturer levels should only be changed by Technical Assistance Service **RIELLO**. Parameters are listed base on the reference menu.

Reference Menu

M1 Parameters Menu

Access type

U End user

Menu	Par. No.	Nr. displayed Display	Description	Range	Default setting	UM	Access type	Category
M1	3	CH set-point	It defines the desired delivery temperature with heating mode (Par. 1 = 0).	Par. 23...Par. 24	70	°C	U	Heating
M1	19	Design Supply Temp.	Defines the max. set-point at the minimum outdoor temperature for climatic regulation.	30...90	80	°C	U	Heating
M1	20	Design Outdoor Temp.	Defines the minimum outdoor temperature to which the maximum set-point can be associated for climatic regulation.	-25...25	0	°C	U	Heating
M1	48	DHW tank set-point	Establishes the DHW storage tank set-point Par. 35 in mode 2.	40...71	50	°C	U	DHW
M1	115	DHW storage tank setp.	Defines the Accumulation sanitary Setpoint in mode 1	40...71	57	°C	U	DHW

## 2 USE

### 2.1 Putting into service

**⚠** The appliance must be maintained and adjusted at least once a year by Technical Assistance Service or by professionally qualified staff in compliance with all applicable National and Local provisions.

**⚠** Incorrect maintenance or adjustment may damage the appliance and cause damage to people or create a hazard.

**⚠** The system manager is forbidden from opening and removing the appliance's casing. These activities must be carried out only by Technical Assistance Service or by professionally qualified personnel.

The thermal module **TAU Unit RIELLO** must be commissioned by Technical Assistance Service **RIELLO**, after which step the appliance may operate automatically.

However, the system manager may be required to restart the appliance independently, without involving Technical Assistance Service; for example after a long period of absence.

To do so, perform the following checks and operations:

- Check that the fuel valves and the water valves of the thermal system are open

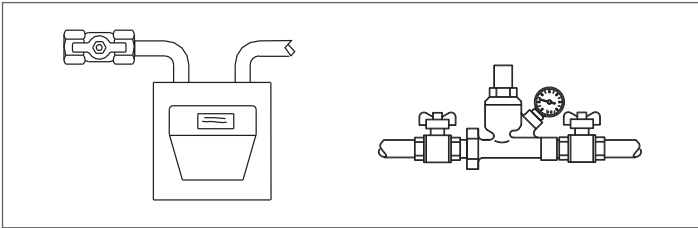

- While the system is still cold, check that working pressure in the central heating circuit is **over 1 bar** but below the maximum limit specified for the boiler

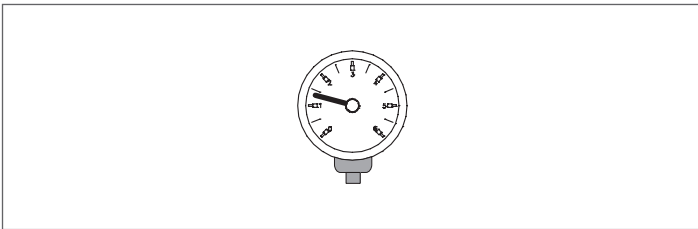

- Adjust the room thermostats for the high and low temperature zones to the required temperature (~20°C) or, if the systems are equipped with timer thermostats or a time programming unit, make sure it is on and adjusted (~20°C)

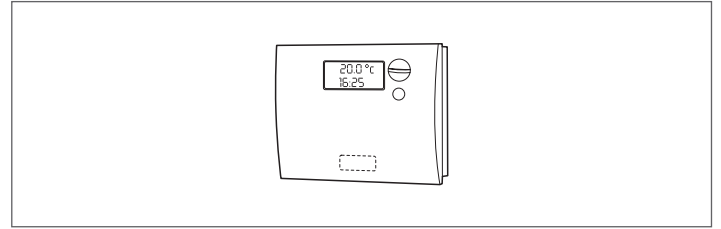

- Switch the system's master switch to the ON position and the thermal module's master switch to (I).

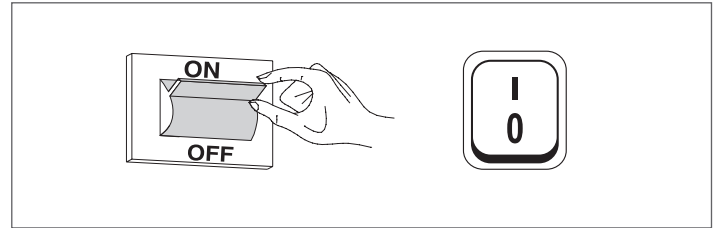

The appliance will go through the switch-on stage and, after starting, it will continue to operate until set temperatures are achieved.

The burner will then switch off and on automatically to maintain the set temperature without further operator action.

In the event of ignition or operation faults, the display will show a numeric error code that will enable the user to interpret the possible cause as detailed in Paragraph "Error List".

**⚠** In the event of a permanent error, to reset starting conditions press the "RESET" key and wait for the thermal module to restart.

Repeat this operation 2-3 times at the most. If the problem persists after that, call **RIELLO's** Technical Assistance Service.

## 2.2 Switching the appliance on and off

After switching the appliance on, the display shall look as shown in the figure below:



External temperature is shown on the display on the left. This value is displayed only if the outdoor temperature sensor (accessory) is installed.

Main setpoint values are shown in the lower side of the display while the time is shown on the top right side.

To turn the equipment off set the main switch "O/I" that is placed on the back side to "O".

**⚠** Never power off the appliance before switching the master switch to the "O" position.

**⚠** Never switch off the appliance with the master switch if a request is active. Always make sure that the appliance is in stand-by before switching the main switch.

## 2.3 Ignition failure

If an anomaly of ignition or operation occurs, a variable message will be indicated on the display of the command interface based on the anomaly found.

Try to manually reset the device by holding down the key "ENTER / RESET" (1).

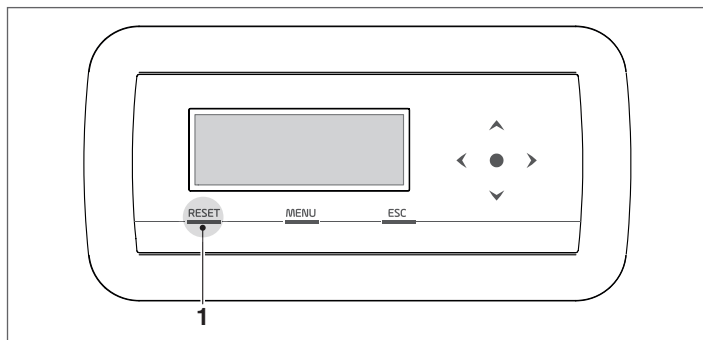

Check the paragraph "Troubleshooting" if the normal operation of the appliance can be restored, otherwise contact the Technical Assistance Service

## 2.4 Date and time setting

Press the MENU key and select "Settings" with the ▲ / ▼ keys

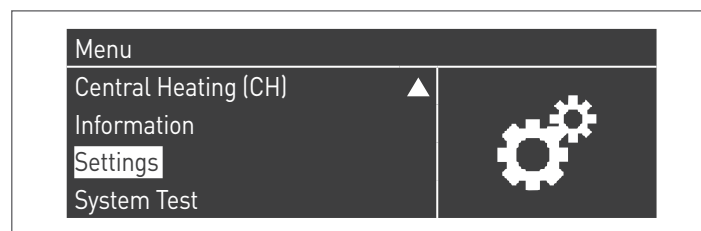

Confirm with the ● key and select "General settings" with the ▲ / ▼ keys



Confirm with the ● key and select "Date and Time " with the ▲ / ▼ keys



Press the ● key, the display will be shown as follows:

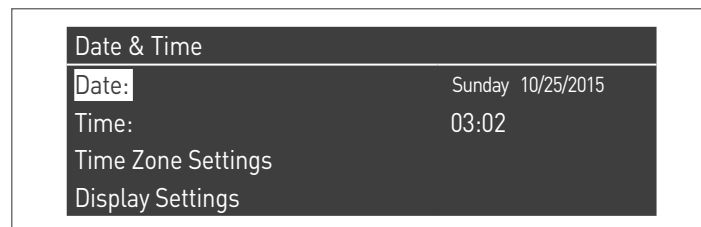

Press the ● key to highlight the values.

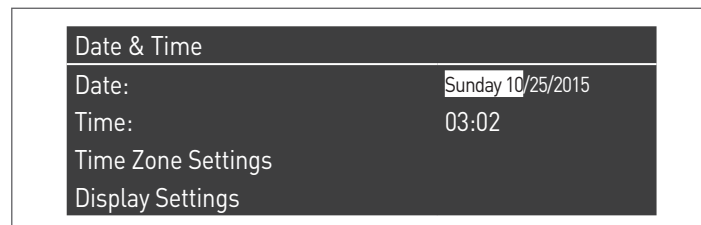

Values can be changed with the ▲ / ▼ keys. Confirm the value entered pressing the ● key and move to the next value.

## Date &amp; Time

Date:	Sunday 10/25/2015
Time:	03:02
Time Zone Settings	
Display Settings	

To set the time, follow the same procedure. By accessing the "Time Zone Settings" menu, it is possible to set the time zone parameter as shown in the figure below:

## Time Zone Settings

Time Zone Correction	UTC +00.00
Daylight Savings Time	Disabled

To change the way in which date and time are displayed, it is possible to change the following characteristics by accessing the "Display Settings" menu:

## Display Settings

Time Notation	24h
Date Order	DMY
Day Of Month	2Digits
Month	2Digits

## Display Settings

Year	4Digits
Date Separation Character	-
Day Of Week	Short Text
Seconds	No

## 2.5 Adjustment of heating setpoint

The set-point value can be entered directly, without entering in the parameter list, by accessing the "CH" menu in the following way:

Press MENU and select "Central heating" using the ▲ / ▼ keys. Press the ● key to confirm.

## Menu

Central Heating (CH)	
Domestic Hot Water (DHW)	
Information	
Settings	

After the selection, use the ► key to highlight the value and use the ▲ / ▼ keys to change the selected value. Press the ● key to confirm/save the new settings.

## Central Heating (CH)

CH Setpoint	61.5 °C
-------------	---------

## 2.6 Adjustment of domestic setpoint

The setpoint value can be set directly, without entering the list of the parameters:

- Press MENU and select "Domestic Hot Water" using the ▲ / ▼ keys.

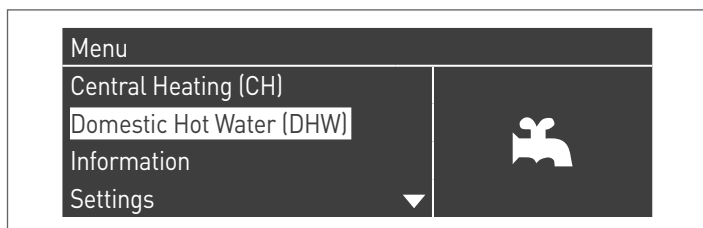

- Press the ● key to confirm.

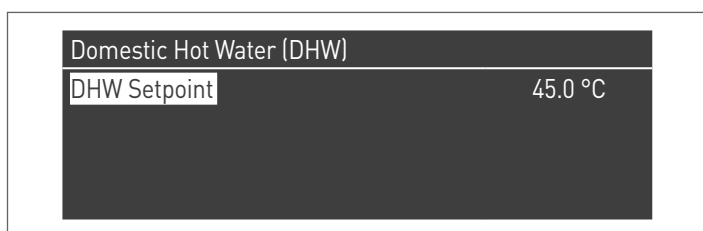

- Use the ► key to highlight the value, and use the ▲ / ▼ keys to change the selected value. Press the ● key to confirm/save the new settings.

## 2.7 Scheduled programme

The Scheduled Programme is designed to program the operation of the various circuits managed by the thermal module, (CH, DHW and additional mixed zones).

### Seasonal Programme

The Seasonal Programme is used to exclude additional mixed zones during the summer season.

It does not control any DHW parameter.

### Holiday Programme

The Holiday Programme is used to exclude part of or all the circuits at a certain time of the year.

A holiday can be set both on the full system and on various groups of circuits.

The group system enables the user to add various circuits to the group to set a holiday period for several circuits at the same time. (For instance, to manage a semi-detached house with a centralised heating system when one of the two families is on holiday and the other is not).

The set-point type can be adjusted so as to correspond to the desired setting.

The system can control up to a total of 16 "Mixed" zones. The programming of mixed areas is only allowed with an accessory. At the same time as these 16 areas, it is also possible to enable the CH zone (direct zone for central heating only).

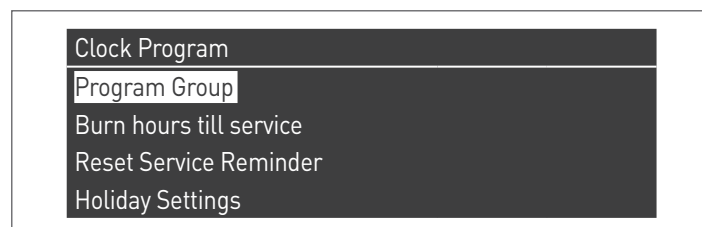

The time programme includes the following parameters:

### Group Programming

Group 1	
Group Holiday	Enabled
Select Ext. Zones in Group	
Select Dep. Zones in Group	

It enables the user to select a group to add zones to the selected group. It also enables the user to enable/disable the group in question.

Group settings are used to add zones to the groups.

The "Group programming" menu enables the use to chose among 8 groups. Each of them can be enabled or disabled. Within it, it is possible to select zones to be added to the group (direct zone (CH) - mixed zones from 1 to 16)

Select Ext. Zones in Group 1		
External Zone	CH	Disabled
External Zone	1	Disabled
External Zone	2	Disabled
External Zone	3	Disabled

**N.B.** The programming of mixed areas is only allowed with an accessory.

### Heating programming

Group 1	
Program Comfort Period	1
Comfort Setpoint	28.0 °C
ECO Setpoint	20.0 °C
Out of interval setpoint	Reduced

It supports adjusting the time programme for the CH zones with the following parameters:

#### Period setting

Enables the user to select a period from 1 to 7. Period settings enable the user to adjust the active periods for this zone.

- **Active days:** Selection of the day (s) on which the period is active. Enables the user to disable the period set for one or more days. When this parameter is set as inactive, the other items on this menu are no longer used and hidden from the view. The choice of active days is between the following macro-groups: Sat-Sun, Mon-Fri, Mon-Sun, or individual days: Mon, Tue, Wed,...
- **Interval 1 (hidden if Active Days is disabled):** This parameter allows the user to regulate the starting and end time of the period. The starting time must always be before the finishing time.
- **Interval 2 (hidden if Active Days is disabled):** Same as interval 1. Interval added for the activated period.
- **Interval 3 (hidden if Active Days is disabled):** Same as interval 1. Interval added for the activated period.

External Zone CH - Period 1		
Active Day(s)	Sunday	
Interval 1	00:00	00:00
Interval 2	00:00	00:00
Interval 3	00:00	00:00

#### Comfort Set-point

Comfort temperature to be used when the zone is in a certain period. (10 -30 °C).

#### ECO set-point

ECO temperature. Adjustable temperature that can be used outside set periods (5 - 20 °C).

#### Set-points outside the interval

Selection of the type of set-point to be used when a zone is not on a set period by selecting between:

- Off
- Comfort
- Eco
- Anti-Freeze (is activated below 5°C NON-ADJUSTABLE)
- Reduced (Calculated as -10°C Comfort Set-point value)

## DHW setting

Group 1	
Program Comfort Period	1
Out of interval setpoint	On

It supports adjusting the time programme for the DHW zone.

### Period setting

Enables the user to select a period from 1 to 7. Period settings enable the user to adjust the active periods for this zone.

- **Active days:** Selection of the day (s) on which the period is active. Enables the user to disable the period set for one or more days. When this parameter is set as inactive, the other items on this menu are no longer used and hidden from the view. The choice of active days is between the following macro-groups: Sat-Sun, Mon-Fri, Mon-Sun, or individual days: Mon, Tue, Wed,...
- **Interval 1 (hidden if Active Days is disabled):** This parameter allows the user to regulate the starting and end time of the period. The starting time must always be before the finishing time.
- **Interval 2 (hidden if Active Days is disabled):** Same as interval 1. Interval added for the activated period.
- **Interval 3 (hidden if Active Days is disabled):** Same as interval 1. Interval added for the activated period.

External Zone DHW - Period 1		
Active Day(s)	Sunday	
Interval 1	00:00	00:00
Interval 2	00:00	00:00
Interval 3	00:00	00:00

### Set-points outside the interval

Selection of the type of set-point to be used when a zone is not on a set period by selecting between:

- Off
- On

## Holiday setting

Holiday Settings	
Mode	Group
Group	1

Enables the user to change parameters for the Holiday Programme.

### Mode

Select the Holiday programme mode. It can be set to Off, System or group.

### Off

Disabled programme

### Group

it enables the selection of the group (1 – 8).

As part of group selection, the Holiday Group is displayed with the following parameters:

- **Holiday set-point:** Set-point type to be used for the selected group. All zones in this group shall use this set-point if the current date is between the start and end date of the holiday period, but only if the group is enabled in the group settings menu, and can be selected from: Off, Comfort, Eco, Anti-freeze and Reduced.
- **Start date / End date (Day DD-MM-YEAR):**

External Zone DHW - Period 1		
Active Day(s)	Sunday	
Interval 1	00:00	00:00
Interval 2	00:00	00:00
Interval 3	00:00	00:00

- **System:** It enables the user to select the holiday programme for the entire system. In this mode, the set-point is common to all system groups.

External Zone DHW - Period 1		
Active Day(s)	Sunday	
Interval 1	00:00	00:00
Interval 2	00:00	00:00
Interval 3	00:00	00:00

- **Holiday set-point (hidden if the Mode is set to "Off"):** Type of reference to be used when system mode is selected. This set-point is used for all areas. Only used for the holiday system.

### Seasonal setting

Enables the user to change parameters for the Seasonal Programme.

The seasonal programme is used to define a period of inactivity for the heating system. This menu includes the following elements:

#### Mode

Selects how the seasonal programme must verify whether heating can be allowed or not. It can be set on:

- **Off:** it means that the seasonal programme is ignored and (CH) heat demand is always allowed throughout the year.



- **At date:** excludes heating (CH+zone) when the current date is included between the start and the end dates.



- **At Temp:** excludes heating (CH+zone) when the outdoor temperature is higher than the selected temperature. (Ext. deactivation T: 0.0 °C/50 °C)

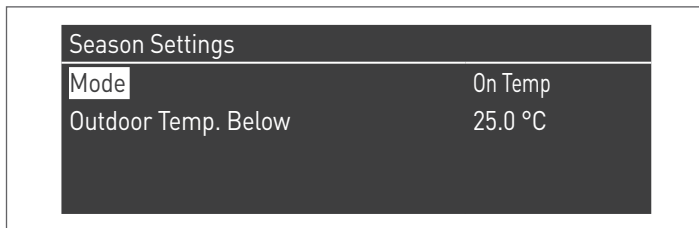

## 2.8 Temporary or short-term shut-down

In the event of temporary or short-term shut-down (e.g. due to holidays), proceed as follows:

- Press the MENU key and select with keys ▲ / ▼ "Time schedule", confirm with key ●.
- Select with keys ▲ / ▼ "Holiday Schedule" and confirm with key ●.

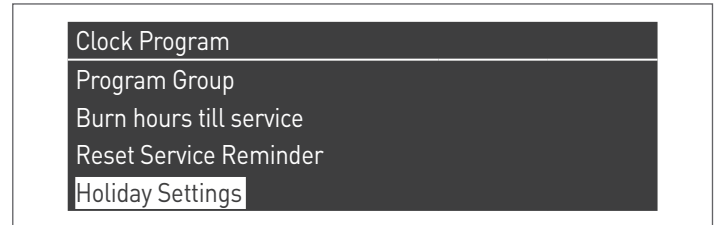

- Select with keys ▲ / ▼ "Mode" and confirm with key ●. Select "System" mode and confirm.

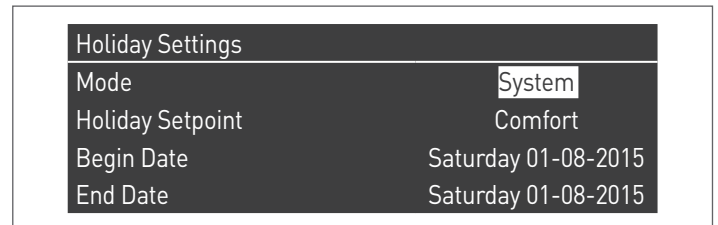

- Select with keys ▲ / ▼ "Holiday Setpoint" and confirm with key ●.
- Select "Antifreeze" holiday setpoint and confirm.

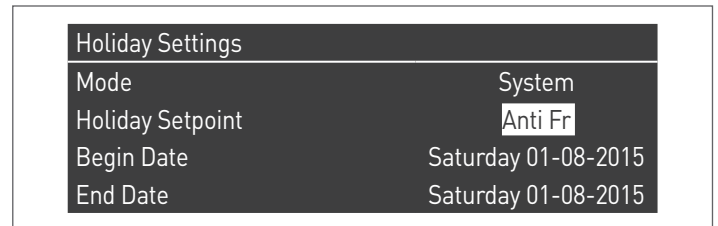

## 2.9 Preparing for extended periods of disuse

Long periods of inactivity of the thermal module **TAU Unit** imply the following operations to be carried out:

- position the main switch of the thermal module and of the system to "off"

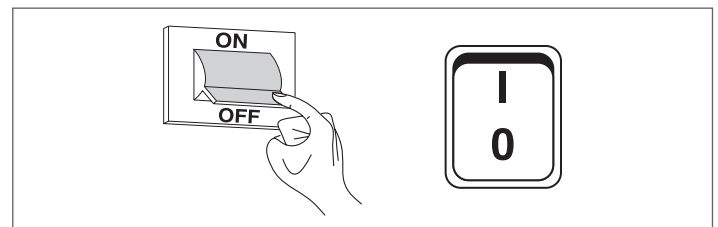

- close the fuel valves and the water valves of the thermal and DHW system.

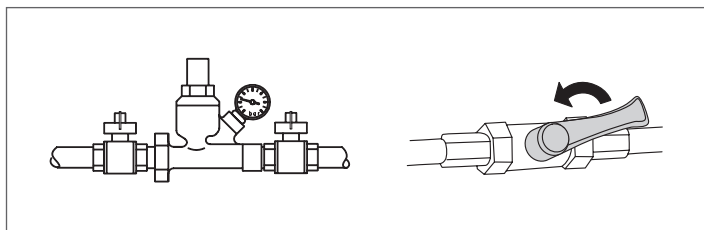

**⚠** Empty the thermal and sanitary system if there is a danger of frost.

## 2.9.1 System filling and emptying

### FILLING

Before starting to recharge, check that the drain valve, on the system, is closed.

- Open the shut-off cocks for the water circuit
- Slowly fill until the pressure gauge reads, when cold, a value of 1,5 bar
- Close the central heating circuit shut-off cocks.

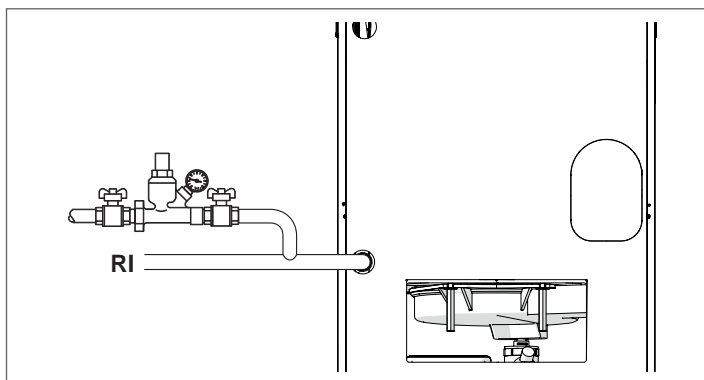

### EMPTYING

Switch the electricity supply OFF at the system's main switch and at the control panel before starting to empty the boiler.

- Close the CH circuit water shut-off cocks

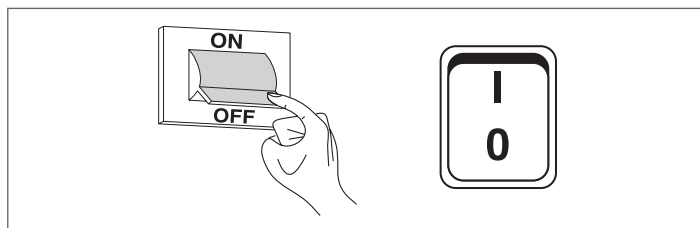

- Connect a plastic tube to the hose barb of the drain valve installed in the system and open it.

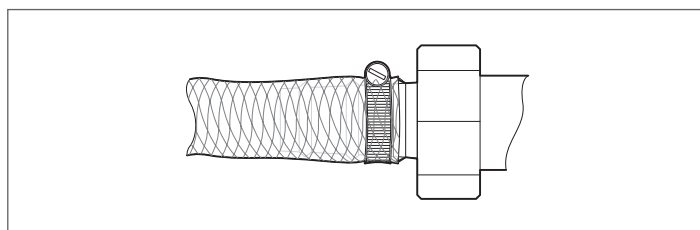

## 2.9.2 CH frost protection

The condensing thermal units **TAU Unit** feature an antifreeze protection that is activated by the thermoregulator if the delivery water temperature drops below 5°C.

**⚠** No special anti-frost additives are therefore needed, unless the system is to be completely shut down for an extended period of time.

**⚠** If you do use anti-freeze in the system, make sure that it is of the type that does not attack steel.

## 2.10 Cleaning

Use a cloth damped in soapy water to clean the boiler's external casing.

To remove stubborn marks, use a cloth damped in a 50% mix of water and denatured alcohol or a suitable cleaning product. Carefully dry after cleaning.

**⊖** Do not use abrasive cleaning pads or powder detergents.

**⊖** Never clean the boiler without first disconnecting it from the mains electricity supply by turning the mains power switch and the control panel switch OFF.

**⚠** The combustion chamber and flue pipes must be cleaned periodically by the manufacturer's Technical Assistance Service or by a qualified heating engineer.

## 2.11 "Service reminder" function

The thermal module is fitted with a function that reminds the user of the need to carry out planned maintenance on the appliance after a number of hours defined in the maintenance plan.

When this maintenance activity is required, the following text appears on the normal display: **"Maintenance required!"**

This text will remain active until the technical support service resets the internal meter after maintaining the appliance.

The user can check at any time how many hours miss from the next planned maintenance activity by accessing the "Information" menu



and selecting "Maintenance" using the ▲ / ▼ arrows



The menu also shows the hours from the last maintenance activity performed and access to a log that lists the dates of the last 15 maintenance activities.

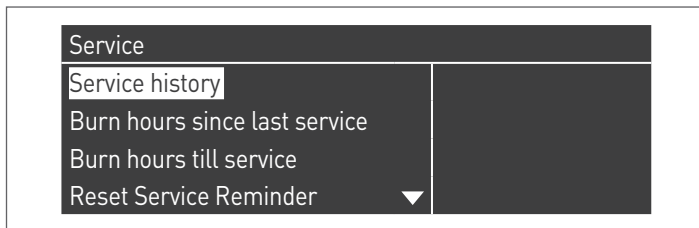

## 2.12 Maintenance

Please remember that THE PERSON RESPONSIBLE FOR SYSTEM MANAGEMENT MUST ENSURE THAT PROFESSIONALLY QUALIFIED HEATING ENGINEERS UNDERTAKE PERIODIC MAINTENANCE AND COMBUSTION EFFICIENCY MEASUREMENTS.

**RIELLO's** Technical Assistance Service is qualified to satisfy these legal requirements and can also provide useful information on MAINTENANCE PROGRAMMES designed to guarantee:

- Greater safety
- Compliance with applicable legislation
- Freedom from the risk of fines in the event of spot checks.

Regular maintenance is essential for the safety, efficiency and durability of the boiler.

Servicing is a legal requirement and must be performed at least once a year by a professionally qualified heating engineer.

 The non-performance of the annual maintenance will invalidate the warranty.

## 2.13 Error List

When a display has a technical fault, a numeric error code appears that will enable the maintenance operator to identify the possible cause.

## 2.14 Troubleshooting

FAULT	CAUSE	SOLUTION
<b>The burner performs pre-ventilation and ignition correctly but shuts down after about 5 attempts</b>	Flame not detected	– Contact your local Technical Assistance Service
	No gas supply	– Check gas valve opening
<b>The burner shuts down during pre-ventilation</b>	Flue blocked	– Contact your local Technical Assistance Service
	Flame detection error	– Contact your local Technical Assistance Service
	The flame is already lit	– Contact your local Technical Assistance Service
	Air intake obstructed	– Contact your local Technical Assistance Service
<b>The burner shuts down after pre-ventilation because the flame fails to ignite</b>	Gas valve feeds too little gas	– Contact your local Technical Assistance Service
	Gas valve faulty	– Contact your local Technical Assistance Service
	Weak or no ignition arc	– Contact your local Technical Assistance Service
	Air in gas line	– Contact your local Technical Assistance Service
<b>The burner does not start when it receives the control signal</b>	No electrical power	– Contact your local Technical Assistance Service
	No gas supply	– Check the opening of the valve in line
	Electrical short circuit	– Contact your local Technical Assistance Service
<b>There is a smell of gas</b>	Leaks from the supply circuit	– Contact your local Technical Assistance Service
<b>There is a smell of fumes</b>	Fumes escaping into the air	– Contact your local Technical Assistance Service
<b>The boiler reaches the set temperature but the radiators are still cold</b>	Air in the circuit	– Bleed the circuit
	Pump malfunctioning	– Contact your local Technical Assistance Service
<b>The boiler does not reach its temperature setpoint</b>	Boiler dirty	– Contact your local Technical Assistance Service
	Burner capacity insufficient	– Contact your local Technical Assistance Service
	Incorrect boiler temperature setpoint	– Check the temperature setting
<b>The generator triggers a thermal safety block</b>	Incorrect boiler temperature setpoint	– Contact your local Technical Assistance Service
	No water	– Check the bleed valve – Check CH circuit pressure



### 3 RECYCLING AND DISPOSAL

The device is primarily composed of:

Materiale	Component
Metal materials	Pipework, boiler body
ABS (acrylonitrile-butadiene-styrene)	Control panel enclosure
Glass wool felt	Boiler body insulation
Electrical and electronic components	Cables and wiring, controller

At the end of the device's useful life, these components must be separated and disposed of according to current regulations in the country of installation.

 Adequate sorted waste collection, processing and environmentally-friendly disposal contribute to preventing possible negative impacts on the environment and health and promote the reuse and/or recycling of the materials of which the appliance consists.

 Illegal disposal of the product by the owner shall be subject to administrative fines provided for by applicable laws.



A series of 20 horizontal dashed lines spanning the width of the page, providing a template for handwriting practice.



A series of 20 horizontal dashed lines spanning the width of the page, providing a template for handwriting practice.

# RIELLO

RIELLO S.p.A.  
Via Ing. Pilade Riello, 7  
37045 - Legnago (VR)  
[www.riello.com](http://www.riello.com)

The manufacturer strives to continuously improve all products. Appearance, dimensions, technical specifications, standard equipment and accessories are therefore liable to modification without notice.