

GB **Forced draught gas burners**

Modulating operation



CODE	MODEL	TYPE
20166113 - 20164535	RS 160/E O ₂ BLU	843T1
20171269 - 20166368	RS 200/E O ₂ BLU	1106T1



Translation of the original instructions

1	Information and general warnings.....	3
1.1	Information about the instruction manual	3
1.1.1	Introduction.....	3
1.1.2	General dangers.....	3
1.1.3	Other symbols	3
1.1.4	Delivery of the system and the instruction manual	4
1.2	Guarantee and responsibility.....	4
2	Safety and prevention.....	5
2.1	Introduction.....	5
2.2	Personnel training	5
3	Technical description of the burner	6
3.1	Burner designation	6
3.2	Models available.....	6
3.3	Burner categories	7
3.4	Technical data	7
3.5	Electrical data.....	7
3.6	Maximum dimensions.....	8
3.7	Firing rates	8
3.7.1	Firing rate on basis of air density	9
3.8	Test boiler.....	10
3.9	Burner equipment.....	10
3.10	Burner description	11
3.11	Flame control (LMV52...).....	12
3.12	Servomotor.....	14
3.13	PLL52... module (Optional)	15
3.13.1	Terminal ratings, cable lengths and cross-sectional areas	15
3.14	Oxygen sensor QGO20 ... (optional).....	16
3.14.1	Technical data QGO20.....	17
3.15	Calibration of the thermal relay	18
4	Installation	19
4.1	Notes on safety for the installation	19
4.2	Handling	19
4.3	Preliminary checks	19
4.4	Operating position	20
4.5	Preparing the boiler	20
4.5.1	Introduction.....	20
4.5.2	Boring the boiler plate	20
4.5.3	Blast tube length.....	21
4.6	Positioning probe - electrode.....	21
4.7	Securing the burner to the boiler	22
4.8	Combustion head adjustment.....	23
4.9	Gas feeding	25
4.9.1	Gas feeding line (Example) - Please refer to the gas train documentation for more information	25
4.9.2	Gas train.....	26
4.9.3	Gas train installation.....	26
4.9.4	Gas pressure.....	26
4.10	Electrical wiring	28
4.10.1	Supply cables and external connections passage	28
5	Start-up, calibration and operation of the burner	29
5.1	Notes on safety for the first start-up	29
5.2	Adjustments prior to ignition	29
5.3	Burner start-up	30
5.4	Burner adjustment	30
5.4.1	Firing output	30
5.4.2	Maximum output.....	30
5.4.3	Minimum output.....	30
5.5	Final calibration of the pressure switches	31

5.5.1	Air pressure switch.....	31
5.5.2	Maximum gas pressure switch.....	31
5.5.3	Minimum gas pressure switch.....	32
5.5.4	PVP pressure switch kit	32
5.6	Steady-state operation	32
5.7	Ignition failure.....	32
5.8	Burner flame goes out during operation.....	32
5.9	Stopping of the burner	33
5.10	Final checks (with burner operating).....	33
5.11	Description of O2 trim control (optional)	34
5.11.1	Operating principle of O2 trim control	34
6	Maintenance	35
6.1	Notes on safety for the maintenance	35
6.2	Maintenance programme	35
6.2.1	Maintenance frequency.....	35
6.2.2	Safety test - with gas feeding closed	35
6.2.3	Checking and cleaning.....	35
6.2.4	Measuring the ionisation current	36
6.2.5	Checking the air and gas pressure on the combustion head	36
6.2.6	Safety components	36
6.3	Opening the burner	37
6.4	Closing the burner.....	37
A	Appendix - Accessories	38
B	Appendix - Electrical panel layout.....	40

1 Information and general warnings

1.1 Information about the instruction manual

1.1.1 Introduction

The instruction manual supplied with the burner:

- is an integral and essential part of the product and must not be separated from it; it must therefore be kept carefully for any necessary consultation and must accompany the burner even if it is transferred to another owner or user, or to another system. If the manual is lost or damaged, another copy must be requested from the Technical Assistance Service of the area;
- is designed for use by qualified personnel;
- offers important indications and instructions relating to the installation safety, start-up, use and maintenance of the burner.

Symbols used in the manual

In some parts of the manual you will see triangular DANGER signs. Pay great attention to these, as they indicate a situation of potential danger.

1.1.2 General dangers

The **dangers** can be of **3 levels**, as indicated below.



Maximum danger level!
This symbol indicates operations which, if not carried out correctly, cause serious injury, death or long-term health risks.



This symbol indicates operations which, if not carried out correctly, may cause serious injury, death or long-term health risks.



This symbol indicates operations which, if not carried out correctly, may cause damage to the machine and/or injury to people.

1.1.3 Other symbols



DANGER: LIVE COMPONENTS
This symbol indicates operations which, if not carried out correctly, lead to electric shocks with lethal consequences.



DANGER: FLAMMABLE MATERIAL
This symbol indicates the presence of flammable materials.



DANGER: BURNING
This symbol indicates the risks of burns due to high temperatures.



DANGER: CRUSHING OF LIMBS
This symbol indicates the presence of moving parts: danger of crushing of limbs.



WARNING: MOVING PARTS
This symbol indicates that you must keep limbs away from moving mechanical parts; danger of crushing.



DANGER: EXPLOSION
This symbol signals places where an explosive atmosphere may be present. An explosive atmosphere is defined as a mixture - under atmospheric conditions - of air and flammable substances in the form of gases, vapours, mist or dust in which, after ignition has occurred, combustion spreads to the entire unburned mixture.



PERSONAL PROTECTION EQUIPMENT
These symbols indicate the equipment that must be worn and kept by the operator for protection against threats against safety and/or health while at work.



OBLIGATION TO ASSEMBLE THE HOOD AND ALL THE SAFETY AND PROTECTION DEVICES
This symbol signals the obligation to reassemble the hood and all the safety and protection devices of the burner after any maintenance, cleaning or checking operations.



ENVIRONMENTAL PROTECTION
This symbol gives indications for the use of the machine with respect for the environment.



IMPORTANT INFORMATION
This symbol indicates important information that you must bear in mind.

- This symbol indicates a list.

Abbreviations used

Ch.	Chapter
Fig.	Figure
Page	Page
Sec.	Section
Tab.	Table

1.1.4 Delivery of the system and the instruction manual

When the system is delivered, it is important that:

- the instruction manual is delivered to the user by the system manufacturer, with the recommendation to keep it in the room where the heat generator is to be installed.
- The instruction manual shows:
 - the serial number of the burner;

.....

- the address and telephone number of the nearest Assistance Centre.

.....

.....

.....

- The system supplier must carefully inform the user about:
 - the use of the system;
 - any further tests that may be required before activating the system;
 - maintenance, and the need to have the system checked at least once a year by a representative of the manufacturer or another specialised technician. To ensure a periodic check, the manufacturer recommends the drawing up of a Maintenance Contract.

1.2 Guarantee and responsibility

The manufacturer guarantees its new products from the installation date, in accordance with the regulations in force and/or the sales contract. At the moment of the first start-up, check that the burner is integral and complete.



WARNING

Failure to observe the information given in this manual, operating negligence, incorrect installation and carrying out of non authorised modifications will result in the annulment by the manufacturer of the guarantee that it supplies with the burner.

In particular, the rights to the guarantee and the responsibility will no longer be valid, in the event of damage to things or injury to people, if such damage/injury was due to any of the following causes:

- incorrect installation, start-up, use and maintenance of the burner;
- improper, incorrect or unreasonable use of the burner;
- intervention of unqualified personnel;
- carrying out of unauthorised modifications on the equipment;
- use of the burner with safety devices that are faulty, incorrectly applied and/or not working;
- installation of untested supplementary components on the burner;
- powering of the burner with unsuitable fuels;
- faults in the fuel supply system;
- use of the burner even following an error and/or an irregularity;
- repairs and/or overhauls incorrectly carried out;
- modification of the combustion chamber with inserts that prevent the regular development of the structurally established flame;
- insufficient and inappropriate surveillance and care of those burner components most likely to be subject to wear and tear;
- the use of non-original components, including spare parts, kits, accessories and optional;
- force majeure.

The manufacturer furthermore declines any and every responsibility for the failure to observe the contents of this manual.

2 Safety and prevention

2.1 Introduction

The burners have been designed and built in compliance with current regulations and directives, applying the known technical rules of safety and envisaging all the potential danger situations. It is necessary, however, to bear in mind that the imprudent and clumsy use of the equipment may lead to situations of death risk for the user or third parties, as well as the damaging of the burner or other items. Inattention, thoughtlessness and excessive confidence often cause accidents; the same applies to tiredness and sleepiness.

It is a good idea to remember the following:

- The burner must only be used as expressly described. Any other use should be considered improper and therefore dangerous.

In particular:

it can be applied to boilers operating with water, steam, diathermic oil, and to other users expressly named by the manufacturer; the type and pressure of the fuel, the voltage and frequency of the electrical power supply, the minimum and maximum deliveries for which the burner has been regulated, the pressurisation of the combustion chamber, the dimensions of the combustion chamber and the room temperature must all be within the values indicated in the instruction manual.

- Modification of the burner to alter its performance and destinations is not allowed.
- The burner must be used in exemplary technical safety conditions. Any disturbances that could compromise safety must be quickly eliminated.
- Opening or tampering with the burner components is not allowed, apart from the parts requiring maintenance.
- Only those parts envisaged by the manufacturer can be replaced.



The manufacturer guarantees safety and proper functioning only if all burner components are intact and positioned correctly.

2.2 Personnel training

The user is the person, body or company that has acquired the machine and intends to use it for the specific purpose. He is responsible for the machine and for the training of the people working around it.

The user:

- undertakes to entrust the machine exclusively to suitably trained and qualified personnel;
- undertakes to inform his personnel in a suitable way about the application and observance of the safety instructions. With that aim, he undertakes to ensure that everyone knows the use and safety instructions for his own duties;
- Personnel must observe all the danger and caution indications shown on the machine.
- Personnel must not carry out, on their own initiative, operations or interventions that are not within their province.
- Personnel must inform their superiors of every problem or dangerous situation that may arise.
- The assembly of parts of other makes, or any modifications, can alter the characteristics of the machine and hence compromise operating safety. The manufacturer therefore declines any and every responsibility for any damage that may be caused by the use of non-original parts.

In addition:



- the user must take all the measures necessary to prevent unauthorised people gaining access to the machine
- the user must inform the manufacturer if faults or malfunctioning of the accident prevention systems are noticed, along with any presumed danger situation
- personnel must always use the personal protective equipment envisaged by legislation and follow the indications given in this manual

3 Technical description of the burner

3.1 Burner designation

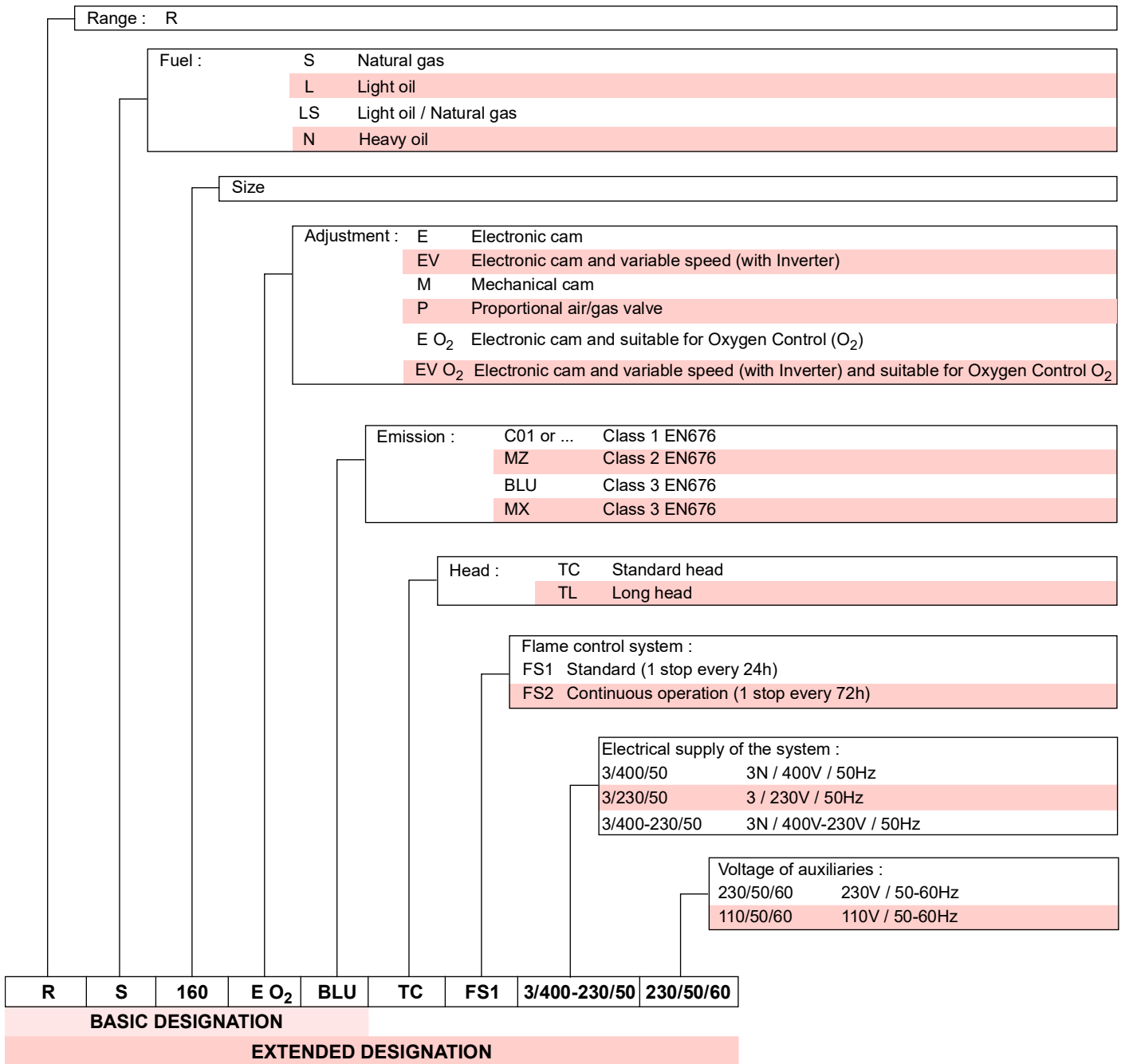

3.2 Models available

Designation		Voltage	Start-up	Code
RS 160/E O ₂ BLU	TC	3~ 400V - 50Hz	Direct	20166113
RS 160/E O ₂ BLU	TL	3~ 400V - 50Hz	Direct	20164535
RS 200/E O ₂ BLU	TC	3~ 400V - 50Hz	Direct	20171269
RS 200/E O ₂ BLU	TL	3~ 400V - 50Hz	Direct	20166368

Tab. A

3.3 Burner categories

Gas category	Country of destination
I2H	AT - BG - CH - CZ - DK - EE - ES - FI - GB - GR - HU - IE - IS - IT - LT - LV - NO - PT - RO - SE - SI - SK - TR
I2E(R)	BE
I2E	LU - PL
I2ELL	DE
I2EK	NL
I2Er	FR

Tab. B
3.4 Technical data

Model	RS 160/E O ₂ BLU		RS 200/E O ₂ BLU
Output ⁽¹⁾	Max.	kW Mcal/h	930 ÷ 1860 800 ÷ 1600
	Min.	kW Mcal/h	300 258
Comustibile	Natural gas: G20 (methane gas) G25 - G31		
Fuel	– Intermittent (min. 1 stop in 24 hours) – Modulating with the kit (see ACCESSORIES)		
Standard applications	Boilers: water. steam. diathermic oil		
Ambient temperature	°C	0 - 40	
Combustion air temperature	°C max	60	
Noise levels ⁽²⁾	Sound pressure	dB(A)	80.5
	Sound power		91.5
Weight ⁽³⁾	kg	96 - 98	101 - 103
CE	CE-0476DP3335		

Tab. C

(1) Reference conditions: Room temperature 20°C - Gas temperature 15°C - Barometric pressure 1013 mbar - Altitude 0 m above sea level.

(2) Sound pressure measured in manufacturer's combustion laboratory, with burner operating on test boiler and at maximum rated output. The sound power is measured with the "Free Field" method, as per EN 15036, and according to an "Accuracy: Category 3" measuring accuracy, as set out in EN ISO 3746.

(3) Blast tube: short-long.

3.5 Electrical data

Model	RS 160/E O ₂ BLU	RS 200/E O ₂ BLU
Main electrical supply	3~ 400V +/-10% 50Hz	
Control circuit power supply	1N~ 230V +/-10% 50Hz	
Absorbed electrical power	kW max	5.5
Protection level	IP 44	

Tab. D

3.6 Maximum dimensions

The dimensions of the burner are shown in Fig. 1.

The dimensions of the open burner are indicated by position I.

Bear in mind that inspection of the combustion head requires the burner to be opened and the rear part drawn back on the guides.

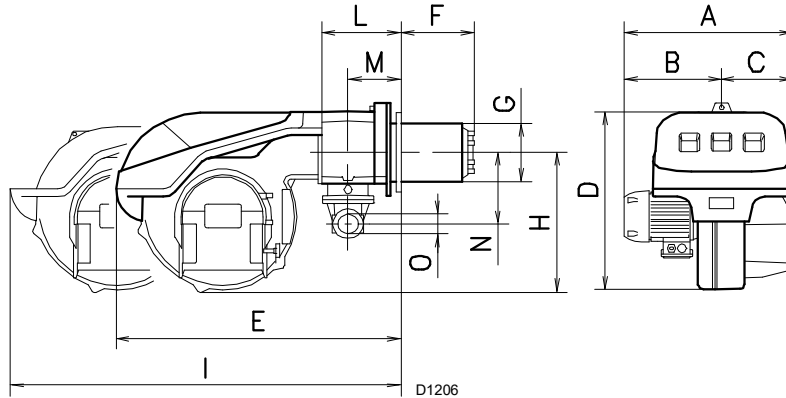

Fig. 1

mm	A	B	C	D	E	F (1)	G	H	I	L	M	N	O
RS 160/E O ₂ BLU	681	366	315	650	1035	373-503	222	435	1442-1587	230	141	260	2"
RS 200/E O ₂ BLU	742	427	315	650	1035	373-503	222	435	1442-1587	230	141	260	2"

Tab. E

(1) Blast tube: short-long

3.7 Firing rates

The **maximum output** is chosen within area A of the diagram (Fig. 2).

The **minimum output** must not be lower than the minimum limit of the diagram.



The firing rate (Fig. 2) was obtained considering a room temperature of 20°C and an atmospheric pressure of 1013 mbar (approx. 0 m above sea level), with the combustion head adjusted as shown at page 23.

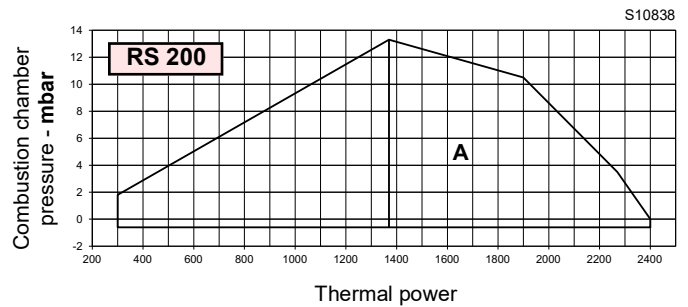
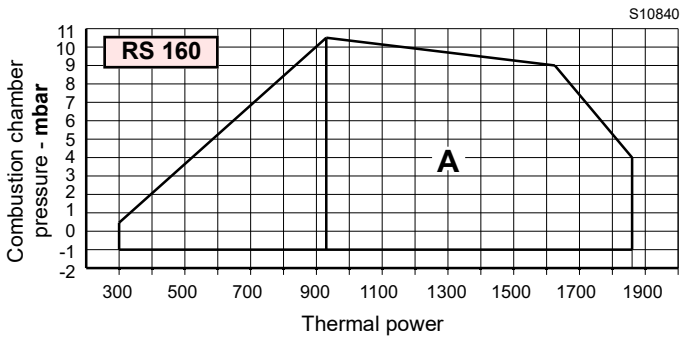

Fig. 2

3.7.1 Firing rate on basis of air density

The firing rate of the burner shown in the manual is valid for a room temperature of 20°C and an altitude of 0m above sea level (barometric pressure around 1013 mbar).

It may be that a burner has to operate with combustive air at a higher temperature and/or higher altitudes.

The heating of the air and the increase in altitude produce the same effect: the expansion of the air volume (i.e. the reduction of its density).

The delivery of the burner fan remains essentially the same, but the oxygen per m³ of air, and the thrust (discharge head) of the fan are reduced.

It is therefore important to know if the maximum output requested from the burner at a determinate combustion chamber pressure remains within the firing rate of the burner even with the changed temperature and altitude conditions.

To check it, proceed as follows:

- 1 find the corrective factor F (relating to the air temperature and altitude of the system) in the Tab. F.
- 2 Divide the output Q required from the burner by F to obtain the equivalent output Qe:

$$Q_e = Q : F \text{ (kW)}$$

- 3 In the firing rate of the burner, mark the work point identified by:

Qe = equivalent output

H1 = pressure in combustion chamber point A that must remain within the firing rate.

- 4 Trace a vertical line from point A)(Fig. 3), and find the maximum pressure H2 of the firing rate.

- 5 Multiply H2 by F to obtain the maximum lowered pressure H3 of the firing rate:

$$H3 = H2 \times F \text{ (mbar)}$$

If H3 is greater than H1)(Fig. 3), the burner can produce the delivery requested.

If H3 is less than H1, it is necessary to reduce the output of the burner. The reduction in output is accompanied by a reduction in the combustion chamber pressure:

Qr = reduced output
H1r = reduced pressure

$$H1r = H1 \times \left(\frac{Qr}{Q}\right)^2$$

Example, 5% reduction in output:

$$Qr = Q \times 0.95$$

$$H1r = H1 \times (0.95)^2$$

With the new values - Qr and H1r - repeat steps 2 - 5.



The combustion head should be adjusted in relation to the equivalent output Qe.

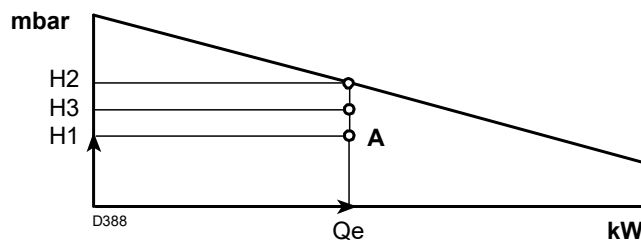

Fig. 3

Altitude	Average barometric pressure	F							
		Air temperature °C							
m a.s.l.	mbar	0	5	10	15	20	25	30	40
0	1013	1.087	1.068	1.049	1.031	1.013	0.996	0.980	0.948
100	1000	1.073	1.054	1.035	1.017	1.000	0.983	0.967	0.936
200	989	1.061	1.042	1.024	1.006	0.989	0.972	0.956	0.926
300	978	1.050	1.031	1.013	0.995	0.978	0.962	0.946	0.916
400	966	1.037	1.018	1.000	0.983	0.966	0.950	0.934	0.904
500	955	1.025	1.007	0.989	0.972	0.955	0.939	0.923	0.894
600	944	1.013	0.995	0.977	0.960	0.944	0.928	0.913	0.884
700	932	1.000	0.982	0.965	0.948	0.932	0.916	0.901	0.872
800	921	0.988	0.971	0.954	0.937	0.921	0.906	0.891	0.862
900	910	0.977	0.959	0.942	0.926	0.910	0.895	0.880	0.852
1000	898	0.964	0.946	0.930	0.914	0.898	0.883	0.868	0.841
1200	878	0.942	0.925	0.909	0.893	0.878	0.863	0.849	0.822
1400	856	0.919	0.902	0.886	0.871	0.856	0.842	0.828	0.801
1600	836	0.897	0.881	0.866	0.851	0.836	0.822	0.808	0.783
1800	815	0.875	0.859	0.844	0.829	0.815	0.801	0.788	0.763
2000	794	0.852	0.837	0.822	0.808	0.794	0.781	0.768	0.743
2400	755	0.810	0.796	0.782	0.768	0.755	0.742	0.730	0.707
2800	714	0.766	0.753	0.739	0.726	0.714	0.702	0.690	0.668
3200	675	0.724	0.711	0.699	0.687	0.675	0.664	0.653	0.632
3600	635	0.682	0.669	0.657	0.646	0.635	0.624	0.614	0.594
4000	616	0.661	0.649	0.638	0.627	0.616	0.606	0.596	0.577

Tab. F

3.8 Test boiler

The firing rates were obtained in special test boilers, according to EN 676 regulations.

Fig. 4 indicates the diameter and length of the test combustion chamber.

Example:

Output 756 kW (650 Mcal/h) - diameter 60 cm, length 2 m.

The coupling is ensured when the boiler is EC type-approved; for boilers or ovens with combustion chambers of very different dimensions compared to those shown in the diagram of Fig. 4, preliminary checks are recommended.

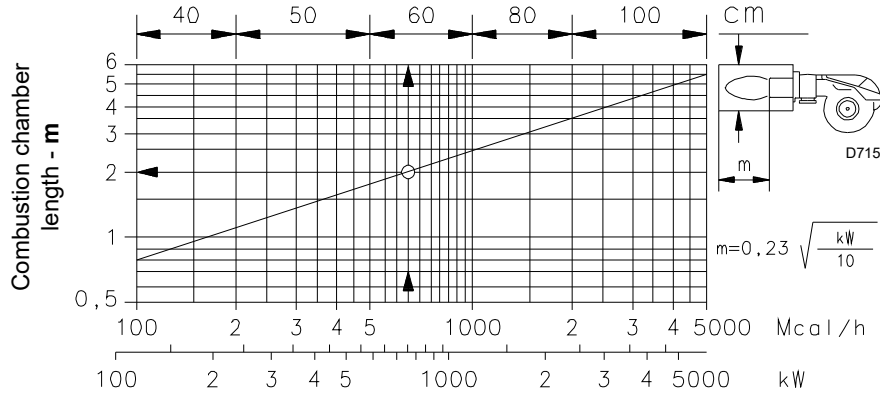

Fig. 4

3.9 Burner equipment

The burner is supplied complete with:

- Gas train flange No. 1
- Gasket for gas train flange No. 1
- Thermal insulation screen No. 1
- Screws M10 x 40 to fix the flange No. 4
- Screws M16 x 50 to fix the burner flange to the boiler . . . No. 4
- Spare parts list No. 1
- Instruction manual No. 1



It is recommended to tighten the screws of the gas flange with a tightening torque of **30 Nm ±10%**.

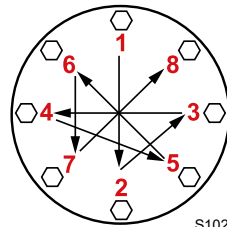

Tighten the nuts gradually (first to 30%, then to 60% up to 100%) according to the cross pattern shown in the figure.

3.10 Burner description

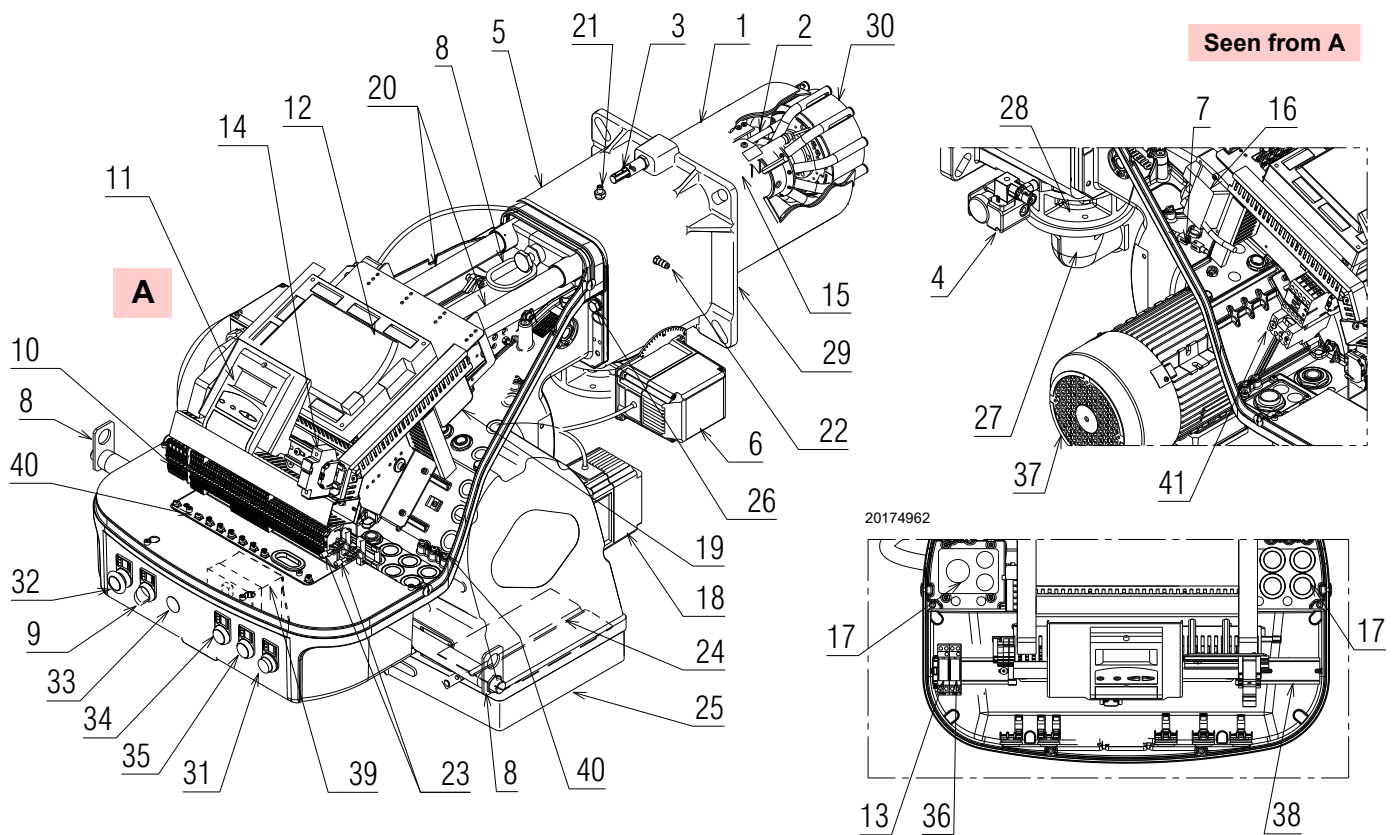

Fig. 5

- | | | | |
|----|---|----|--|
| 1 | Combustion head | 33 | Hole available |
| 2 | Ignition electrode | 34 | "POWER ON" indicator light |
| 3 | Screw for combustion head adjustment | 35 | "FUEL ON" indicator light |
| 4 | Maximum gas pressure switch | 36 | "K3" relay |
| 5 | Pipe coupling | 37 | Fan motor |
| 6 | Gas servomotor | 38 | Support rail for fuse holder and available for accessories |
| 7 | Plug-socket on ionisation probe cable | 39 | Transformer flame control "T1" |
| 8 | Lifting rings | 40 | Ground screws |
| 9 | Operation on/off switch | 41 | Contactor + relay |
| 10 | Terminal board for electrical wiring | | |
| 11 | Operator panel with LCD display | | |
| 12 | Flame control | | |
| 13 | "K6" relay | | |
| 14 | Fuses of auxiliaries | | |
| 15 | Flame inspection window | | |
| 16 | Ignition transformer | | |
| 17 | Cable grommets for electrical wiring (to be carried out by the installer) | | |
| 18 | Air servomotor | | |
| 19 | Minimum air pressure switch (differential operating type) | | |
| 20 | Slide bars for opening the burner and inspecting the combustion head | | |
| 21 | Gas pressure test point and head fixing screw | | |
| 22 | Air pressure socket | | |
| 23 | Terminals for shielding cables | | |
| 24 | Air damper | | |
| 25 | Fan air inlet | | |
| 26 | Screws to secure fan to pipe coupling | | |
| 27 | Gas input pipe | | |
| 28 | Gas butterfly valve | | |
| 29 | Boiler fixing flange | | |
| 30 | Flame stability disk | | |
| 31 | "BURNER LOCK-OUT AND RESET" button | | |
| 32 | "EMERGENCY STOP" button | | |

3.11 Flame control (LMV52...)

Warnings



To avoid accidents, material or environmental damage, observe the following instructions!

The LMV52... flame control is a safety device! Avoid opening or modifying it, or forcing its operation. Riello S.p.A. cannot assume any responsibility for damage resulting from unauthorised interventions!

Risk of explosion!

An incorrect configuration can provoke fuel overcharging, with the consequential risk of explosion! Operators must be aware that incorrect settings made on the AZL5... display and operating unit and incorrect settings of the fuel and / or air actuator positions can lead to dangerous burner operating conditions.

- All interventions (assembly and installation operations, assistance, etc.) must be carried out by qualified personnel.
- Before modifying the wiring in the LMV52 flame control connection area, fully disconnect the system from the power supply (omnipolar separation). Check the system is not powered and cannot be accidentally reconnected. Failure to do this will lead to the risk of electrocution.
- Protection against electrocution from the LMV5... flame control and all connected electric components is obtained with correct assembly.
- Before any intervention (assembly and installation operations, assistance, etc.), ensure the wiring is in order and that the parameters are correctly set, then make the safety checks.
- Falls and collisions can negatively affect the safety functions.
In this case, the flame control must not be operated, even if it displays no evident damage.
- In programming mode, the position check of actuators and VSD (checking electronic fuel / air ratio control) is different from the check during automatic operation.
As for automatic operation, the actuators are guided together to the positions requested and, if an actuator does not reach the position requested, adjustments are made until the position is actually reached. However, in contrast to automatic operation, there are no time limits to these corrective actions.
The other actuators maintain their positions until all actuators have reached the positions currently required.
This is absolutely important to set the fuel / air ratio control system.
During the time the fuel / air ratio curves are being programmed, the person making the plant settings must continuously monitor the quality of the combustion process (e.g. by means of a flue gas analyzer).
Also, if combustion levels are poor, or in the event of dangerous situations, the commissioning engineer must take appropriate action (e.g. switching off manually).

To ensure the safety and reliability of the LMV52... system, the following instructions must also be followed:

- avoid conditions that can favour the development of condensate and humidity. Otherwise, before switching on again, make sure that the entire flame control is perfectly dry!
- Static charges must be avoided since they can damage the flame control's electronic components when touched.



D9301

Fig. 6

Mechanical structure

The LMV52... flame control is a system to check the burners, based on a microprocessor and equipped with components to adjust and monitor medium and large capacity forced draught burners.

The base flame control of the LMV52... system incorporates the following components:

- Burner control with gas valve proving system
- Electronic fuel / air ratio control with a maximum of 6 actuators
- Optional PID temperature / pressure controller (load controller)
- Optional VSD module Mechanical design

Installation notes

- Check the electric wiring inside the boiler complies with the national and local safety regulations.
- Do not confuse the powered conductors with the neutral ones.
- Make certain that strain relief of the connected cables is in compliance with the relevant standards (e.g. as per DIN EN 60730 and DIN EN 60 335).
- Ensure that spliced wires cannot get into contact with neighboring terminals. Use adequate ferrules.
- Arrange the HV ignition cables separately, as far as possible from the flame control and the other cables.
- The burner manufacturer must protect unused AC 230 V terminals with dummy plugs (refer to sections Suppliers of other accessory items).
- When wiring the unit, make sure that AC 230 V mains voltage cables are run strictly separate from extra low-voltage cables to avoid risks of electrical shock hazard.

Electrical connection of ionization probe and flame sensor

It is important for signal transmission to be almost totally free of any disturbances or loss:

- always separate the detector cables from the other cables:
 - Line capacitance reduces the magnitude of the flame signal.
 - Use a separate cable.
- Respect the allowed cable lengths.

- The ionisation probe is not protected against the risk of electrocution. When connected to the electricity supply, the ionisation probe must be protected against any accidental contact.
- **Position the ignition electrode and the ionisation probe so that the ignition spark cannot form an arc on the probe (risk of electric overcharge).**

Technical data

LMV52... base flame control	Mains voltage	AC 230V -15% / +10%
	Mains frequency	50 / 60 Hz ±6 %
	Power absorption	< 30W (normal)
	Safety class	I, with components in compliance with II and III, according to DIN EN 60730-1
Load on 'input' terminals	F1 unit fuse (internal)	6.3 AT
	Main fuse of perm. network (external)	Max. 16 AT
	Undervoltage	
	• Safety switch-off from operating position to mains voltage	< AC 186 V
	• Restart when mains voltage picks up	> AC 188 V
	Oil pump / magnetic clutch (nominal voltage)	
• Nominal current	2A	
• Power factor	cosφ > 0.4	
Load on 'output' terminals	Air pressure switch test valve (nominal voltage)	
	• Nominal current	0.5A
	• Power factor	cosφ > 0.4
	Total load on the contacts:	
	• Mains voltage	AC 230 V -15 % / +10 %
	• Total unit input current (safety circuit) load on contacts due to:	Max. 5 A
- Fan motor contactor		
- Ignition transformer		
- Valve		
- Oil pump / magnetic clutch		
Cable lengths	Single contact loading:	
	Fan motor contactor (nominal voltage)	
	• Nominal current	1A
	• Power factor	cosφ > 0.4
	Alarm output (nominal voltage)	
	• Nominal current	1A
	• Power factor	cosφ > 0.4
	Ignition transformer (nominal voltage)	
	• Nominal current	2A
	• Power factor	cosφ > 0.2
	Fuel gas valve (nominal voltage)	
	• Nominal current	2A
• Power factor	cosφ > 0.4	
Fuel oil valve (nominal voltage)		
• Nominal current	1A	
• Power factor	cosφ > 0.4	
Environmental conditions	Main line	Max. 100 m (100 pF/m)
	Operation	DIN EN 60721-3-3
	Climatic conditions	Classe 3K3
	Mechanical conditions	Classe 3M3
	Temperature range	-20...+60°C
Humidity	< 95% RH	

Tab. G

3.12 Servomotor

Warnings



To avoid accidents, material or environmental damage, observe the following instructions!

Avoid opening, modifying or forcing the actuators.

- All interventions (assembly and installation operations, assistance, etc.) must be carried out by qualified personnel.
- Before modifying the wiring in the SQM4... system connection area, fully disconnect the burner control device from the power supply (omnipolar separation).
- To avoid the risk of electrocution, protect the connection terminals in a suitable manner and correctly fix the cover.
- Check the wiring is in order.
- Falls and collisions can negatively affect the safety functions. In this case, the unit must not be operated, even if it displays no evident damage.

Assembly notes

- Check the relevant national safety standards are respected.
- The connection between the actuator command shaft and the control element must be rigid, without any mechanical play.
- To avoid an excessive load on the bearings due to rigid hubs, the use of compensation clutches without any mechanical play is recommended (e.g. metal bellows-type clutches).

Installation notes

- Arrange the H.V. ignition cables separately, as far as possible from the flame control and the other cables.
- To avoid the risk of electrocution, make sure that the 230V AC section of the SQM4... unit is fully separated from the functional low-voltage section.
- The static torque is reduced when the electrical supply of the actuator is switched off.
- The housing cover may only be removed for short periods of time for wiring or when making the addressing. In similar cases, make sure that dust or dirt does not penetrate inside the actuator.
- The actuator comprises a PCB with ESD-sensitive components.
- The top side of the board carries a cover which affords protection against direct contact. This protective cover must not be removed! The underside side of the board must not be touched.



During the maintenance or replacement of the actuators, be careful not to invert the connectors.

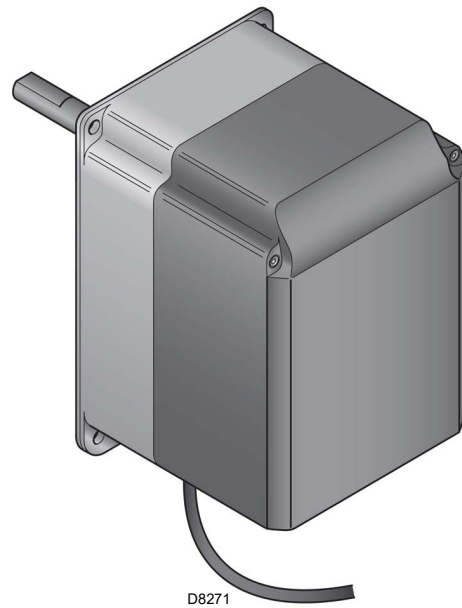

Fig. 7

Technical data

Model	SQM45.295A9	SQM48.497A9
Operating voltage	AC 2 x 12 V via bus cable from the base unit or via a separate transformer	
Safety class	extra low-voltage with safe isolation from mains voltage	
Power consumption	9...15 VA	26...34 VA
Degree of protection	to EN 60 529, IP 54, provided adequate cable entries are used	
Cable connection	RAST3.5 connectors	
Rotation direction	- Anticlockwise (standard) - Clockwise (inverted rotation)	
Nominal torque (max)	1.5 Nm	20 Nm
Holding torque (max)	3 Nm	20 Nm
Weight	approx. 1 kg	approx. 1.6 kg
Environmental conditions:		
Operation	DIN EN 60 721-3-1	
Climatic conditions	Classe 1K3	
Mechanical conditions	Classe 1M2	
Temperature range	-20...+60 °C	
Humidity	< 95% RH	

Tab. H



Condensation, formation of ice and the entrance of water are not permitted!

3.13 PLL52... module (Optional)

Warnings



To avoid accidents, material or environmental damage, observe the following instructions!

Avoid opening, modifying or forcing the device.

- All interventions (assembly and installation operations, assistance, etc.) must be carried out by qualified personnel.
- Falls and collisions can negatively affect the safety functions. In this case, the unit must not be operated, even if it displays no evident damage.

Assembly notes

- Check the relevant national safety standards are respected.

3.13.1 Terminal ratings, cable lengths and cross-sectional areas

Cable lengths / cross-sectional areas	
Electrical connection "X89"	Screw terminals up to max. 2.5 mm ²
Cable lengths	≤ 10 m fino a QGO20...
Cross-sectional areas	Refer to description of QGO20...
Analog inputs	
Air temperature detector	Pt1000 / LG-Ni1000
Flue gas temperature	Pt1000 / LG-Ni1000
QGO20...	Refer to data sheet N7842
Interface	Communication bus for LMV52...

Tab. I



Fig. 8

Technical data

Model	PLL52...
Mains voltage "X89-01"	AC 230 V -15%/10%
Safety class	I class with parts according to II class (DIN EN 60730-1)
Mains frequency	50 / 60 Hz ±6 %
Power consumption	Ca. 4 VA
Degree protection	IP54, housing closed
Transformer AGG5.220	
- Primary side	AC 230V
- Secondary side	AC 12 V (3x)
Environmental conditions:	
Storage	DIN EN 60721-3-1
Climatic conditions:	Class 1K3
Mechanical conditions:	Class 1M2
Temperature range:	-20...+60 °C
Humidity:	<95% r.h.
Transport	DIN EN 60721-3-2
Climatic conditions:	Class 2K2
Mechanical conditions:	Class 2M2
Temperature range:	-25...+70 °C
Humidity:	<95% r.h.
Operation	DIN EN 60 721-3-1
Climatic conditions:	Class 3K5
Mechanical conditions:	Class 3M2
Temperature range:	-20...+60 °C
Humidity:	< 95% r.h.

Tab. J

NOTE:

For detailed information, refer to the specific manual of PLL52 module.



Condensation, formation of ice and the entrance of water are not permitted!

3.14 Oxygen sensor QGO20 ... (optional)

Warnings



WARNING

To avoid accidents, material or environmental damage, observe the following instructions!

Avoid opening, modifying or forcing the oxygen sensor.

- All interventions (assembly and installation operations, assistance, etc.) must be carried out by qualified personnel.
- Before modifying the wiring in the sensor connection area, fully disconnect the burner control device from the power supply (omnipolar separation).
- Ensure that the sensor cannot be inadvertently switched on again and check this by making a voltage test.
- To avoid the risk of electrocution, protect the connection terminals in a suitable manner and correctly fix the cover.
- During operation, the flange of the sensor connection must be kept closed; all screws must be tightened securely.
- Check the wiring is in order.
- Falls and collisions can negatively affect the safety functions. In this case, the unit must not be operated, even if it displays no evident damage.
- Ensure that the device does not get into contact with explosive or inflammable gases.
- There is a risk of burning since the measuring cell works at an operating temperature of 700 °C and other accessible parts can get very hot too (> 60 °C).
- To prevent injury caused by the hot immersion tube, remove the device only after the equipment has cooled down.
- Make certain that the sensor's inlet and outlet are always kept free from dirt.
- Before cleaning the inlet and outlet, allow the sensor to cool down for at least 1 hour.
- Mount the sensor such that the connecting part (head to flange) is free so that the exchange of air is ensured. Otherwise, measurements might get distorted, possibly leading to dangerous situations.
- Ensure that there are no chemicals, such as solvent vapors, near the sensor.

Installation notes

- The flue gas flow passing the measuring cell must be homogeneous, with no or only little turbulence. When mounted too close to air dampers or pipe bends, faulty measurements can occur.
- A number of faults can distort the measurements (this can lead to dangerous situations in connection with oxygen trim control):
 - If the stack is not tight, false air can join the flue gases.
 - In that case, the residual oxygen content indicated by the sensor is higher than it actually is.
 - If the flue gas velocity is low, the sensor's response is slower, since the flue gases take more time to pass the measuring cell. In that case, it is recommended to mount the sensor in an inclined position (refer to the manual).
 - The greater the sensor's distance from the flame, the longer the dead time.

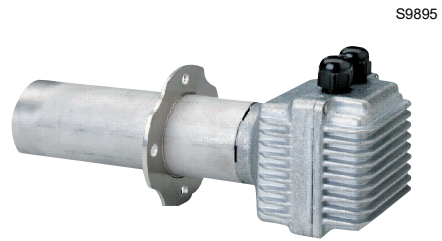

Fig. 9

NOTE:

For further explanations about the wiring connections, please refer to the manual supplied with the accessory code 20045187.



WARNING

Condensation, formation of ice and the entrance of water are not permitted!

3.14.1 Technical data QGO20

Operating voltage of measuring cell's:	
– QGO20.000D27	AC 230 V ±15 %
– QGO20.000D17	AC 120 V ±15 % (only with LMV52 ... with PLL52...)
Mains frequency:	50...60 Hz ±6 %
Power consumption:	Max. 90 W, typical value 35 W (controlled)
Permissible mounting position:	Refer to mounting Instructions M7842
Degree of protection:	IP40, to be ensured through installation
Weight (net):	approx. 0.9 kg
Signal lines	
– Shielded 6-wires cable	Twisted pairs
– Shielding connected to terminal GND of the PL52...	
Wire diameter	LiFYCY3x2x0,2 o LYCY3x2x0,2
Measuring system	Zirconium dioxide measuring cell as an oxygen ion conductor
Permissible flue gas velocity (only with AGO20...)	1...10 m/s
Fuel type	Fuel oil EL or Natural gas H
Measuring range	0.2...20.9 % O ₂
Permissible cable length	Max. 100 m
Wire diameter	<10 m
Power supply lines (Net cable)	Min. 1 mm ²
– Cable diameter	QGO20.000D27: e.g. NYM 3 x 1,5
– Cable type	QGO20.000D17: UL AWM Style 1015/MTW or CSA-AWM/TEW
Required operating temperature of measuring cell	700 °C ±50 °C
Environmental conditions	
Storage	DIN EN 60721-3-1
Climatic conditions:	Class 1K3
Mechanical conditions:	Class 1M2
Temperature range:	-20...+60 °C
Humidity:	<95% r.h.
Transport	DIN EN 60721-3-2
Climatic conditions:	Class 2K2
Mechanical conditions:	Class 2M2
Temperature range:	-25...+70 °C
Humidity:	<95% r.h.
Operation	DIN EN 60721-3-3
Climatic conditions:	Class 3K5
Mechanical conditions:	Class 3M2
Temperature range:	
– Flange	Max. 250 °C
– Connecting head	Max. 70 °C
– Flue gases	≤300 °C
Humidity:	<95% r.h.
Installation altitude:	Max. 2000 m a.s.l.

Tab. K

3.15 Calibration of the thermal relay

The thermal relay serves to avoid damage to the motor due to an excessive absorption increase or if a phase is missing.

For calibration **2)**, see the table in the wiring diagram.

To reset, in case of an intervention of the thermal relay, press the "RESET" button **1)** of Fig. 10.

The red "TEST" button **3)** opens the NC (95-96) contact and stops the motor.



CAUTION

The automatic reset can be dangerous. This operation is not foreseen in the burner operation. **Therefore do not position the "RESET" button 1) on "A".**

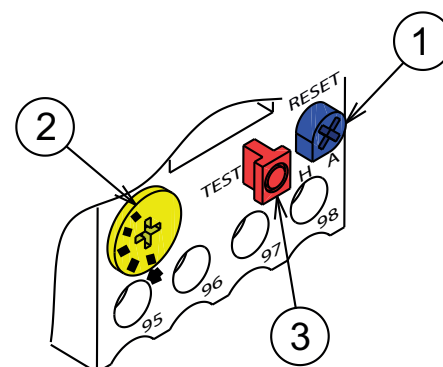

20073932

Fig. 10

4.4 Operating position



- The burner is designed to operate only in positions 1, 2, 3 and 4 (Fig. 12).
- Installation 1 is preferable, as it is the only one that allows the maintenance operations as described in this manual.
- Installations 2, 3 and 4 permit operation but make maintenance and inspection of the combustion head more difficult.



- Any other position could compromise the correct operation of the appliance.
- Installation 5 is prohibited for safety reasons.

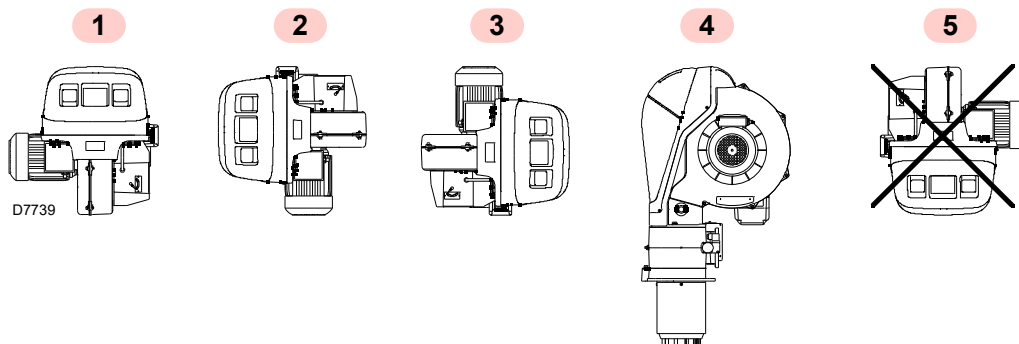

Fig. 12

4.5 Preparing the boiler

4.5.1 Introduction

The burners are suitable for working on both flame inversion boilers (*) (in this case the long head model is recommended) and boilers with a combustion chamber with bottom runoff (three flue gas circulations), from which the best results of low NO_x emissions are obtained.

The maximum thickness of the front hatch of the boiler A)(Fig. 13), complete with refractory, must not exceed:

Blast tube	A (mm)
RS 160-200/E O ₂ BLU	250

Tab. L

(*) For flame inversion boilers, a kit is available to reduce the CO. See Accessories.

The kit consists of 5 gas tubes, identical to the other 5 already present in the burner head. In standard conditions, the head of the burner is fitted with a second group of tubes, from which the gas emerges in a different direction compared with the others.

With the kit, this second group of tubes is substituted so that all the tubes are the same.

After assembling the kit, check its efficiency by measuring the flue gases and CO.

4.5.2 Boring the boiler plate

Drill holes in the plate shutting off the combustion chamber, as illustrated in Fig. 14.

The position of the threaded holes can be marked using the thermal insulation screen supplied with the burner.

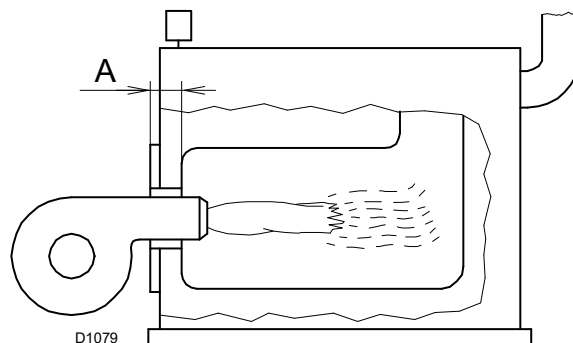

Fig. 13

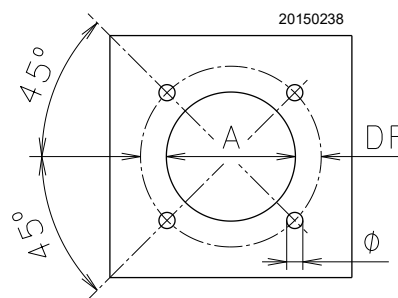

Fig. 14

mm	A	DF	Ø
RS 160-200/E O ₂ BLU	230	325 - 368	M 16

Tab. M

4.5.3 Blast tube length

The length of the blast tube must be selected according to the indications provided by the manufacturer of the boiler, and in any case it must be greater than the thickness of the boiler door complete with its refractory.

The lengths L available are:

Blast tube	Short (mm)	Long (mm)
RS 160-200/E O ₂ BLU	373	503

Tab. N

For boilers with front flue passes 13)(Fig. 17 at page 22), or flame inversion chambers, a protection in refractory material 11) must be inserted between the boiler refractory 12) and the blast tube 10).

This protection must not compromise the extraction of the blast tube.

4.6 Positioning probe - electrode



WARNING

Before fixing the burner to the boiler, check from the opening of the blast tube that the probe and the electrode are correctly positioned, as in Fig. 16.

If, in the previous check, the position of the probe or electrode was not correct, is necessary:

- remove the screw 1)(Fig. 15)
- extract the inner part 2)(Fig. 15) of the head, and adjust them.



WARNING

Do not rotate the probe: leave it as in Fig. 16. If it is located too close to the ignition electrode, the flame control amplifier may be damaged.



WARNING

Observe the dimensions shown in Fig. 16.

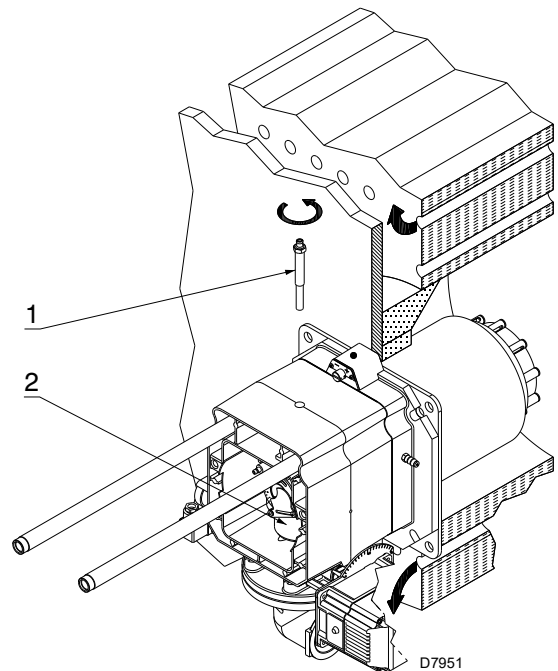

Fig. 15

20184506

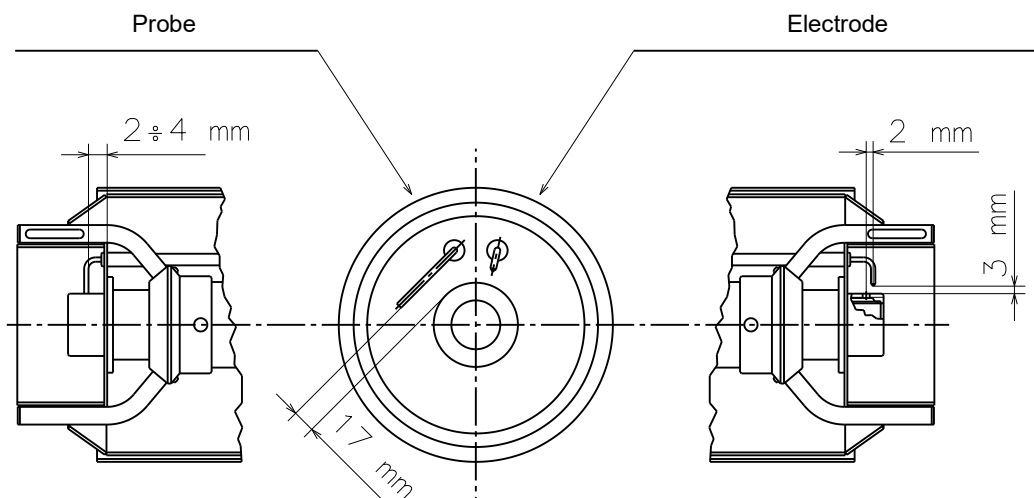

Fig. 16

4.7 Securing the burner to the boiler



Provide an adequate lifting system of the burner.

Separate the combustion head from the rest of the burner, as in Fig. 17; proceed as follows:

- loosen the 4 screws 3) and remove the hood 1);
- remove the screws 2) from the two guides 5);
- disconnect the socket from the maximum gas pressure switch;
- remove the two screws 4);
- pull back the burner on the guides 5) by about 100 mm;
- disconnect the probe and electrode leads, then unthread the burner completely from the guides.

Once this operation has been carried out:

- fix the flange 9) to the boiler plate, interposing the insulating gasket 8) supplied.
- Use the 4 screws supplied, with a tightening torque of 35 - 40 Nm, after protecting their thread with anti-seize products.



WARNING

The seal between burner and boiler must be airtight; after the start-up, check there is no leakage of flue gases into the external environment.

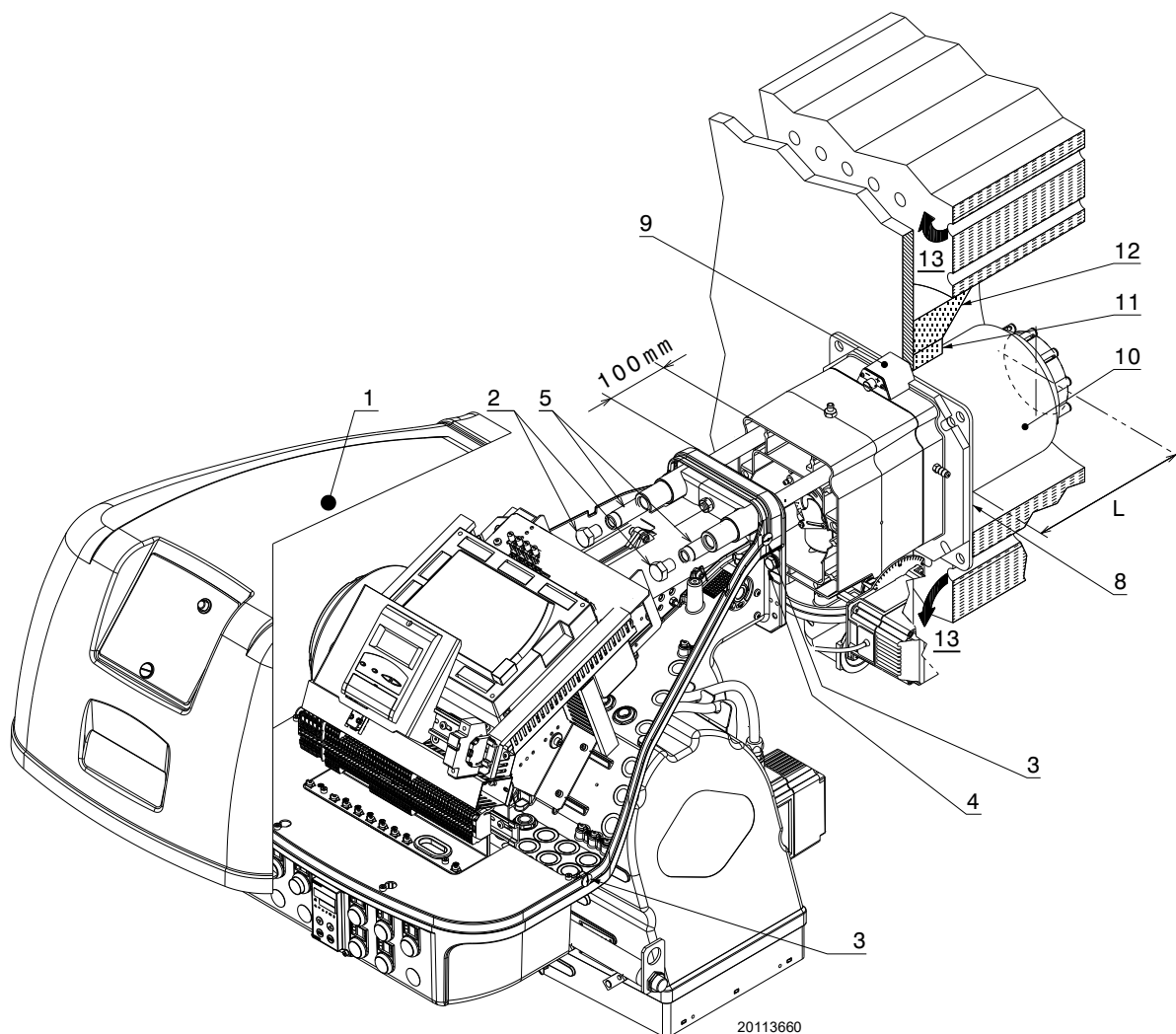

Fig. 17

4.8 Combustion head adjustment

At this point of the installation, the combustion head is fixed to the boiler as shown in Fig. 15.

It is therefore especially easy to adjust, and this adjustment depends only on the maximum output of the burner.

Two adjustments of the head are foreseen:

- external air R1
- central air R2

In the diagram (Fig. 20) find the notch at which to adjust both air and central air.

External air R2 adjustment

- Rotate the screw 4)(Fig. 18 - Fig. 19) until the notch you have found corresponds with the front surface 5) of the fitting.



WARNING

To facilitate adjustment, loosen the screw 6), adjust and then lock.

Central air R3 adjustment

- Loosen the 2 screws 1) and rotate the ring nut 2) until the notch you have found corresponds with the screw 1).
- Block the 2 screws 1).

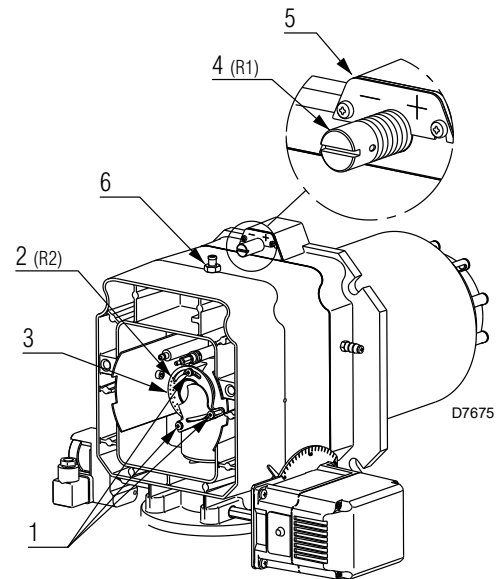

Fig. 18

20127192

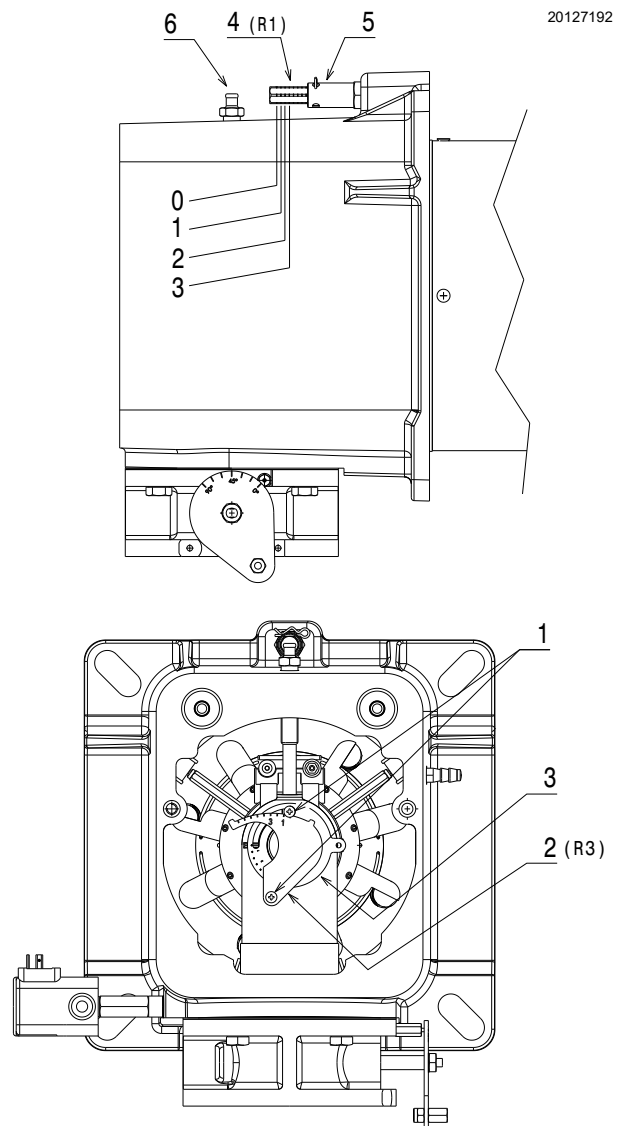

Fig. 19

Example:

burner output = 500 kW.

For this output, according to diagram Fig. 20, the adjustments to do are:

- R1 air= notch 6
- R2 central gas/air= notch 2

NOTE:

the diagram (Fig. 20) indicates the optimum adjustment for a type of boiler according to Fig. 4 at page 10.



WARNING

The adjustments indicated can be modified during the initial start-up.

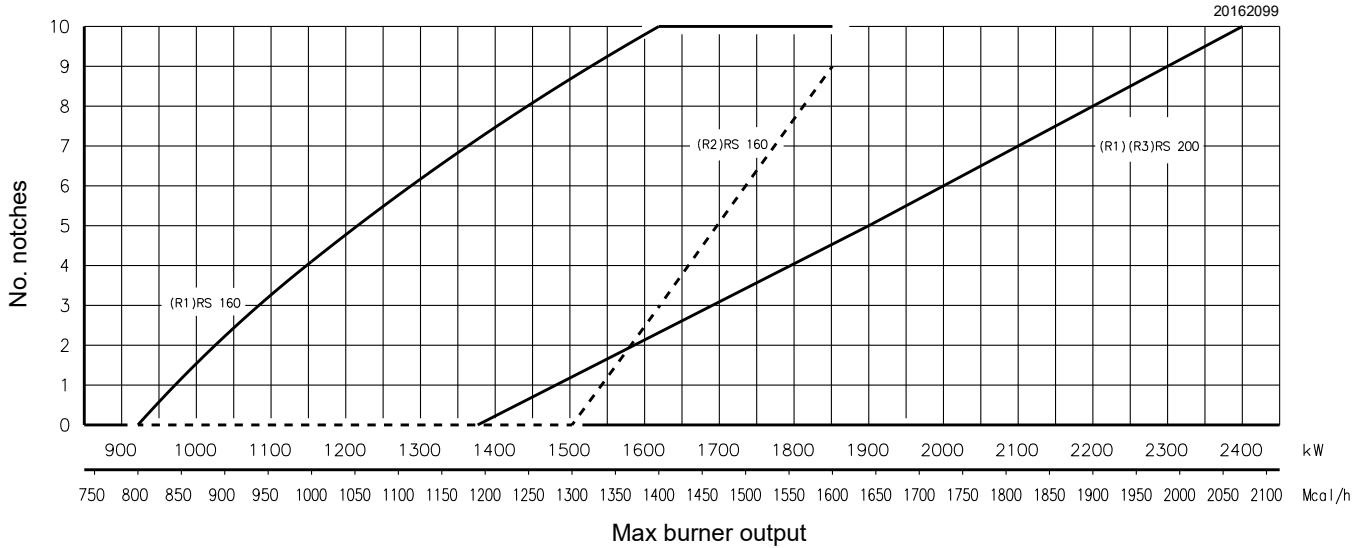

Fig. 20

Once the combustion head adjustment is completed:

- reassemble the burner on the guides 3) at about 100 mm from the pipe coupling 4) - burner in the position shown in Fig. 17;
- insert the probe and electrode cables, then slide the burner as far as the pipe coupling - burner in the position shown in Fig. 21;
- connect the socket of the maximum gas pressure switch;
- refit the screws 2) on the guides 3);
- fix the burner to the pipe coupling with the screws 1).



WARNING

When fitting the burner on the two guides, it is advisable to gently draw out the high voltage cable and flame detection probe cable until they are slightly taut.

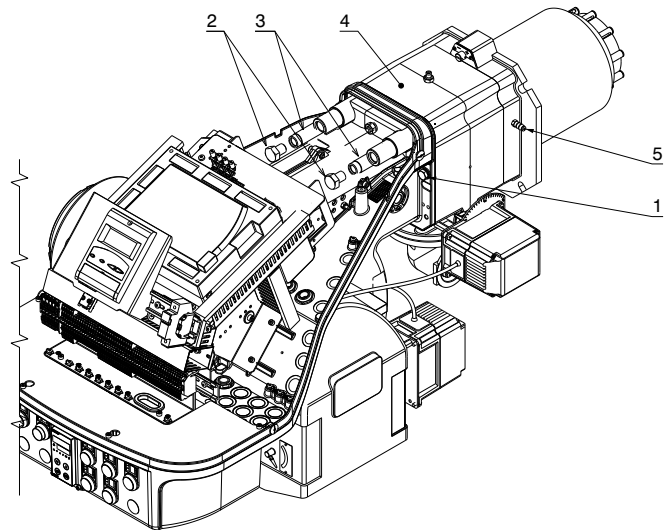

Fig. 21

4.9 Gas feeding



Explosion danger due to fuel leaks in the presence of a flammable source.
 Precautions: avoid knocking, attrition, sparks and heat.
 Make sure that the fuel interception tap is closed before performing any operation on the burner.



The fuel supply line must be installed by qualified personnel, in compliance with current standards and laws.

4.9.1 Gas feeding line (Example) - Please refer to the gas train documentation for more information

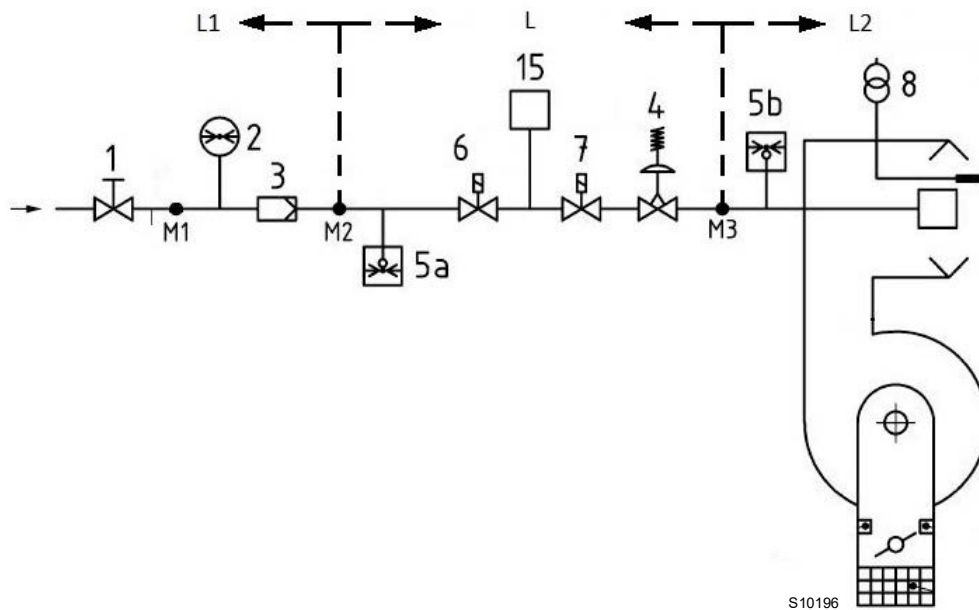

S10196

Fig. 22

Key (Fig. 22)

- 1 Manually operated shut-off valve
- 2 Pressure gauge
- 3 Filter
- 4 Governor
- 5a Low pressure protection device
- 5b Maximum gas pressure switch
- 6 1st safety shut-off device
- 7 2nd safety shut-off device
- 8 Ignition device
- 15 Valve leak detection control system
- L Gas train (supplied separately)
- L1 Responsibility of the installer
- L2 Burner
- M1 Pressure test point
- M2 Pressure test point
- M3 Pressure test point

4.9.2 Gas train

Type-approved in accordance with EN 676 and supplied separately from the burner.

4.9.3 Gas train installation



Disconnect the electrical power using the main system switch.



Check that there are no gas leaks.



Beware of train movements: danger of crushing of limbs.



Make sure that the gas train is properly installed by checking for any fuel leaks.



The operator must use appropriate tools for installation.

The gas train can enter the burner from the right or left side, depending on which is the most convenient, see Fig. 23.

The gas train must be connected to the gas attachment 1)(Fig. 23), with the flange 2), the gasket 3) and the screws 4) supplied with the burner.



The gas solenoids must be as close as possible to the burner, to ensure that the gas reaches the combustion head within the safety time of 3s.

Ensure that the maximum pressure to the burner is within the calibration range of the pressure regulator.

See the accompanying instructions for the adjustment of the gas train.

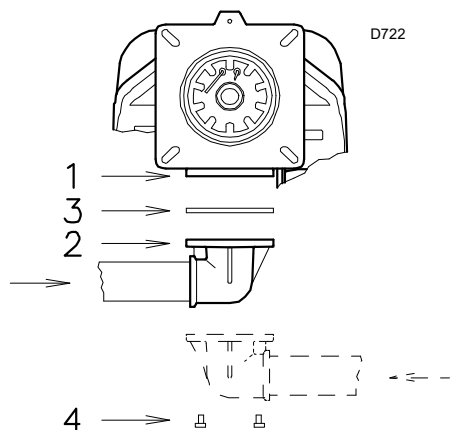

Fig. 23

4.9.4 Gas pressure

Tab. O indicates the pressure drop of the combustion head and the gas butterfly valve depending on the operating output of the burner.

	kW	1 Δp (mbar)		2 Δp (mbar)	
		G 20	G 25	G 20	G 25
RS 200/E O ₂ BLURS 160/E O ₂ BLU	930	5.6	8.4	0.0	0.0
	1100	7.5	11.2	0.0	0.0
	1300	9.7	14.5	0.8	1.2
	1600	13.0	19.4	3.0	4.5
	1860	17.7	26.4	3.8	5.7
	1383	9.0	13.4	3.1	4.7
	1500	10.7	16.0	3.7	5.5
	1800	14.7	21.9	5.3	7.9
	2100	20.3	30.3	7.2	10.7
	2400	28.0	41.8	9.4	14.0

Tab. O

The values shown in Tab. O refer to:

- Natural gas G 20 NCV 9.45 kWh/Sm³ (8.2 Mcal/Sm³)
- Natural gas G 25 NCV 8.13 kWh/Sm³ (7.0 Mcal/Sm³)

Column 1

Load loss at combustion head.

Gas pressure measured at the test point 1)(Fig. 24), with:

- combustion chamber at 0 mbar;
- burner working at maximum output;

Column 2

Pressure loss at gas butterfly valve 2)(Fig. 24) with maximum opening: 90°.

To know the approximate output at which the burner is operating at its maximum:

- Subtract the combustion chamber pressure from the gas pressure measured at test point 1)(Fig. 24).
- Find, in the Tab. O relating to the burner concerned, column 1, the pressure value closest to the result you want.
- Read the corresponding output on the left.

Example with natural gas G 20:

Maximum output operation

Gas pressure at test point 1)(Fig. 24)	=	16.0 mbar
Pressure in combustion chamber	=	3.0 mbar
$16.0 - 3.0$	=	13.0 mbar

A maximum output of 1600 kW shown in Tab. O corresponds to 20.3 mbar pressure, column 1.

This value serves as a rough guide; the effective output must be measured at the gas meter.

To know the required gas pressure at test point 1)(Fig. 24), set the maximum output required from the burner operation, then:

- find the nearest output value in the Tab. O for the burner in question.
- Read, on the right (column 1) the socket pressure 1)(Fig. 24).
- Add this value to the estimated pressure in the combustion chamber.

Example with natural gas G 20:

Required burner maximum output operation: 1600 kW

Gas pressure at output of 1600 kW = 13.0 mbar

Pressure in combustion chamber = 3.0 mbar

13 + 3.0 = 16.0 mbar

pressure required at test point 1)(Fig. 24).

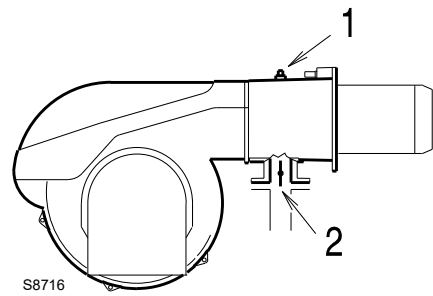

Fig. 24



The heat output and gas pressure data in the head refer to operation with gas butterfly valve fully open (90°).

4.10 Electrical wiring

Notes on safety for the electrical wiring



- The electrical wiring must be carried out with the electrical supply disconnected.
- Electrical wiring must be made in accordance with the regulations currently in force in the country of destination and by qualified personnel. Refer to the wiring diagrams.
- The manufacturer declines all responsibility for modifications or connections different from those shown in the wiring diagrams
- Check that the electrical supply of the burner corresponds to that shown on the identification label and in this manual.
- The burner has been type-approved for intermittent use. This means they should compulsorily be stopped at least once every 24 hours to enable the flame control to perform checks of its own start-up efficiency. Normally, burner stopping is guaranteed by the boiler's thermostat/pressure switch. If this is not the case, a time switch should be fitted in series to TL to stop the burner at least once every 24 hours. Refer to the wiring diagrams.
- The electrical safety of the device is obtained only when it is correctly connected to an efficient earthing system, made according to current standards. It is necessary to check this fundamental safety requirement. In the event of doubt, have the electrical system checked by qualified personnel. Do not use the gas tubes as an earthing system for electrical devices.
- The electrical system must be suitable for the maximum power absorption of the device, as indicated on the label and in the manual, checking in particular that the section of the cables is suitable for that level of power absorption.
- For the main power supply of the device from the electricity mains:
 - do not use adapters, multiple sockets or extensions;
 - use a multiple pole switch with at least a 3mm gap between the contacts (overvoltage category III), as envisaged by the present safety standards.
- Do not touch the device with wet or damp body parts and/or in bare feet.
- Do not pull the electric cables.

Before carrying out any maintenance, cleaning or checking operations:



Disconnect the electrical supply from the burner by means of the main system switch.



Close the fuel interception tap.



Avoid condensate, ice and water leaks from forming.

If the hood is still present, remove it and proceed with the electrical wiring according to the wiring diagrams.

Use flexible cables in compliance with the EN 60 335-1 standard.

4.10.1 Supply cables and external connections passage

All the cables to be connected to the burner should be passed through cable grommets, as shown in Fig. 25.

The use of the cable grommets can take various forms. By way of example we indicate the following mode:

- A Fan motor
- B Maximum gas pressure switch
- C Air servomotor
- D O₂ control
- E Air pressure switch
- 1 Three phase power supply with M32 cable grommet.
- 2 Available: single phase power supply and other devices with hole for M20
- 3 Available: consents/safety, minimum gas pressure switch, gas valves and other devices with M20 cable grommet.
- 4 Available: hole for M16
- 5 Available: hole for M20
- 6 Available for ground terminals

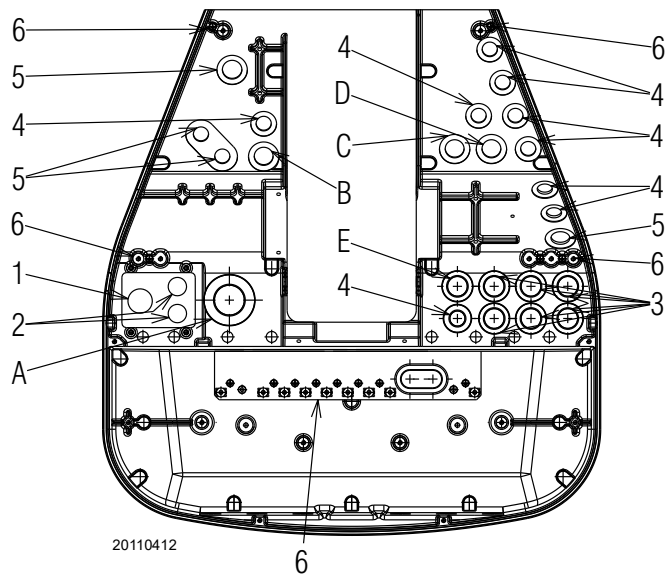

Fig. 25



After carrying out maintenance, cleaning or checking operations, reassemble the hood and all the safety and protection devices of the burner.

5 Start-up, calibration and operation of the burner

5.1 Notes on safety for the first start-up



The first start-up of the burner must be carried out by qualified personnel, as indicated in this manual and in compliance with the standards and regulations of the laws in force.



Check the correct working of the adjustment, command and safety devices.



Before igniting the burner, see the paragraph “Safety test - with gas feeding closed” on page 35.

5.2 Adjustments prior to ignition

The adjustments to be carried out are:

- ensure that the gas supply company has carried out the supply line vent operations, eliminating air or inert gases from the piping.
- Slowly open the manual valves situated upstream of the gas train.
- Adjust the minimum gas pressure switch (Fig. 30 at page 32) to the start of the scale.
- Adjust the maximum gas pressure switch (Fig. 29 at page 31) to the end of the scale.
- Adjust the air pressure switch (Fig. 28 at page 31) to the start of the scale.
- Adjust the pressure switch for the valve leak detection control device (PVP Kit)(Fig. 31 at page 32), if present, according to the instructions supplied with the Kit itself.
- Check the gas supply pressure by connecting a pressure gauge to the pressure test point 1)(Fig. 26) of the minimum gas pressure switch: it must be lower than the maximum allowed pressure of the gas train, as shown on the characteristics label.



An excessive gas pressure can damage the components of the gas train and lead to a risk of explosion.

- Bleed the air from the piping of the gas train, connecting a plastic tube to the pressure test point 1)(Fig. 26) of the minimum gas pressure switch. Take the vent tube outside the building so you can notice the smell of gas.
- Connect two lamps or testers to the two gas line solenoids to check the exact moment at which voltage is supplied. This operation is unnecessary if each of the two solenoids is equipped with an indicator light that signals voltage passing through.



Before starting up the burner, it is good practice to adjust the gas train so that ignition takes place in conditions of maximum safety, i.e. with gas delivery at the minimum.

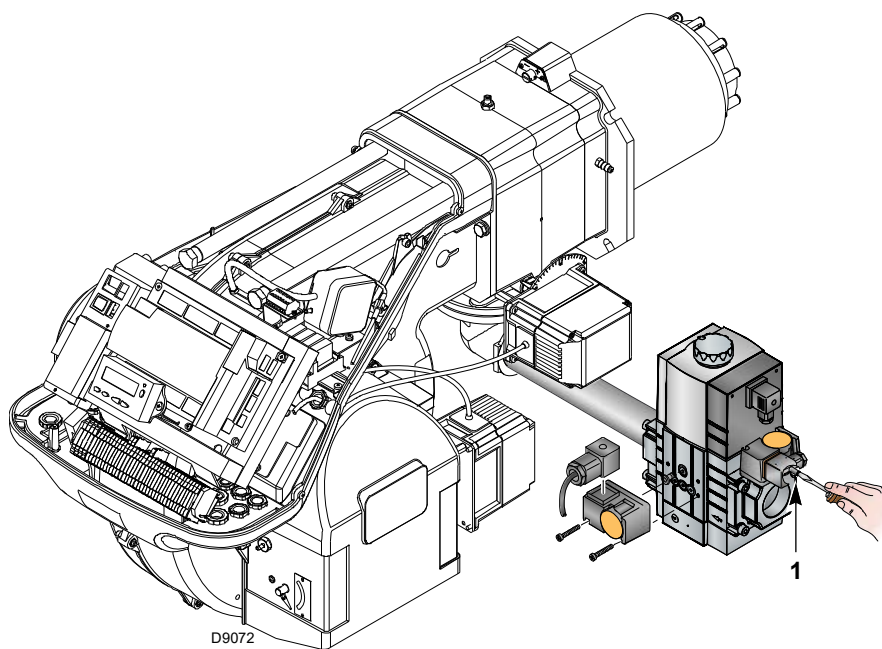

Fig. 26

5.3 Burner start-up

Feed electricity to the burner via the disconnecting switch on the boiler panel.

Close the thermostats/pressure switches and turn the switch to Fig. 27 "AUTO".



Make sure that the lights or testers connected to the solenoids, or the pilot lights on the solenoids themselves, indicate that no voltage is present.

If voltage is present, then **immediately** stop the burner and check the electrical wiring. When the burner starts, check the direction of the rotation of the motor, as shown in Fig. 27.

As soon as the burner starts up, go in front of the cooling fan of the fan motor and check it is rotating anticlockwise.

If this is not the case:

- place the switch of Fig. 27 in position "0" and wait for the flame control to carry out the switch-off phase;
- disconnect the burner from the electrical supply;
- invert the phases on the three-phase power supply.

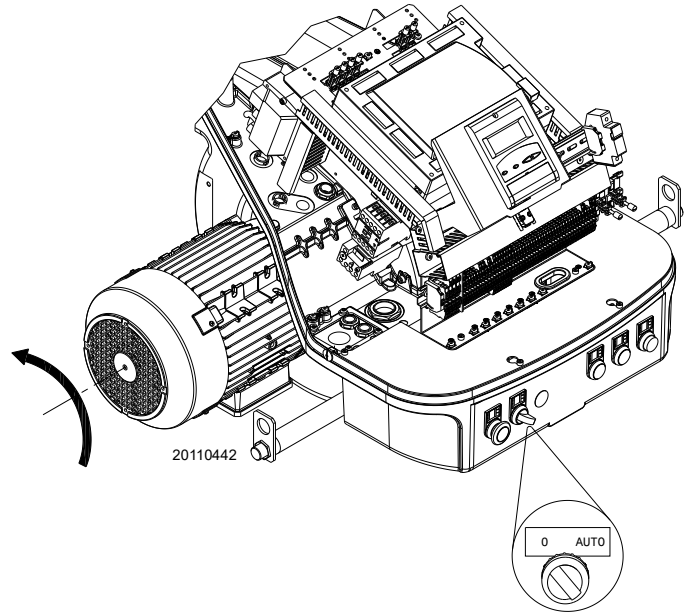

Fig. 27

5.4 Burner adjustment

5.4.1 Firing output



For safety purposes and correct product operation, the ignition output, if it is adjustable, must be carried out by authorized personnel and in compliance with the standards and regulations of the laws in force.

5.4.2 Maximum output

The MAX output must be set within the firing rate (Fig. 2 at page 8).

Gas adjustment

Measure the gas delivery on the meter.

As a general rule, this value can be found on Tab. O at page 26, just read the gas pressure on the pressure gauge (Fig. 34 at page 36) and follow the indications given on page 26.

- If it is necessary to reduce it, lower the output gas pressure via the pressure adjuster located beneath the gas valve.
- If it needs to be increased, increase the output gas pressure via the adjuster.

Air adjustment

If necessary vary the degrees of the air servomotor.

5.4.3 Minimum output

The MIN output must be set within the firing rate (Fig. 2 at page 8).

5.5 Final calibration of the pressure switches

5.5.1 Air pressure switch

Adjust the air pressure switch (Fig. 28) after having performed all other burner adjustments with the air pressure switch set to the start of the scale.

With the burner working at MIN output, insert a combustion analyser in the stack, slowly close the suction inlet of the fan (for example, with a piece of cardboard) until the CO value does not exceed 100 ppm.

Slowly turn the appropriate knob clockwise until the burner goes into lockout.

Check the indication of the arrow pointing upwards on the graduated scale. Turn the knob clockwise again, until the value shown on the graduated scale corresponds with the arrow pointing downwards, and so recovering the hysteresis of the pressure switch (shown by the white mark on a blue background, between the two arrows).

Now check the correct start-up of the burner. If the burner locks out again, turn the knob slightly anticlockwise. During these operations it may be useful to measure the air pressure with a pressure gauge.

The connection of the pressure gauge is shown in Fig. 28. The standard configuration is that with the air pressure switch connected in absolute mode. Note the presence of a "T" connection, not supplied.

In certain applications in strong depression situations, the connection of the pressure switch does not allow it to change over. In this case it is necessary to connect the pressure switch in differential mode, applying a second tube between the air pressure switch and the fan suction line mouth.

In this case also, the pressure gauge must be connected in differential mode, as shown in Fig. 28.



Connecting the air pressure switch in differential mode, the burner will no longer be certified according to the EN 676 standard.

5.5.2 Maximum gas pressure switch

Adjust the maximum gas pressure switch (Fig. 29) after making all other burner adjustments with the maximum gas pressure switch set to the end of the scale.

To calibrate the maximum gas pressure switch, open the tap and then connect a pressure gauge to its pressure test point.

The maximum gas pressure switch must be regulated to a value no higher than 30% of the measurement read on the gauge when the burner is working at maximum output.

After making the adjustment, remove the pressure gauge and close the tap.

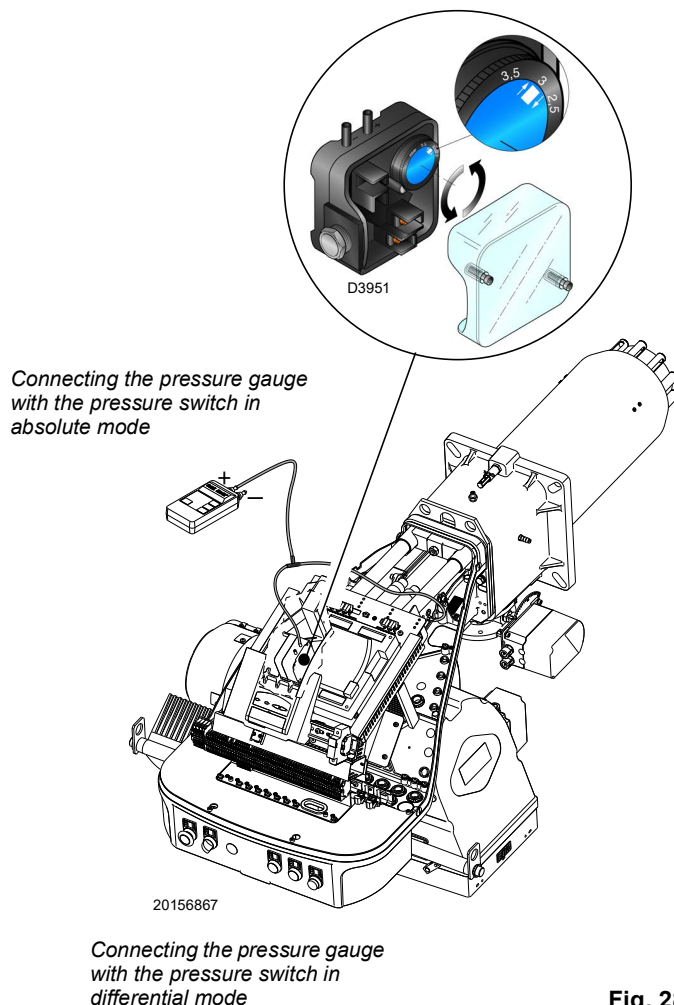

Fig. 28

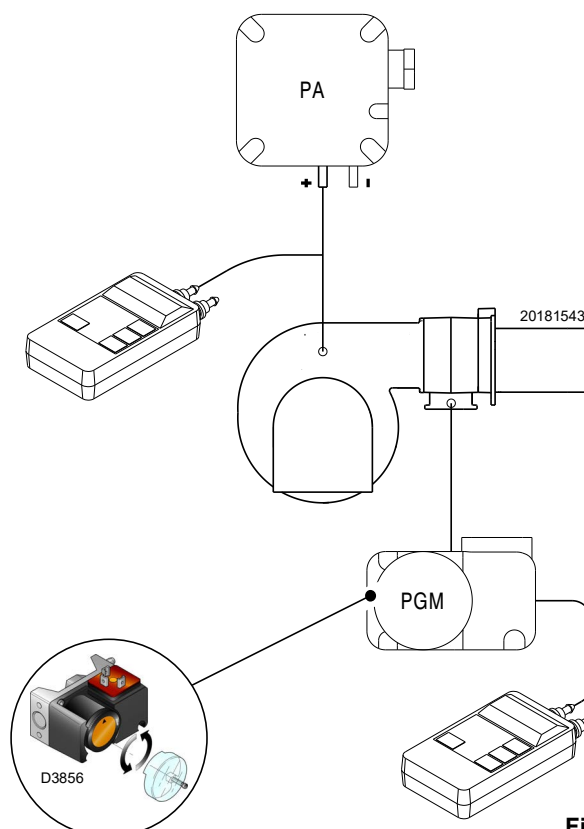

Fig. 29

5.5.3 Minimum gas pressure switch

The purpose of the minimum gas pressure switch is to prevent the burner from operating in an unsuitable way due to too low gas pressure.

Adjust the minimum gas pressure switch (Fig. 30) after having adjusted the burner, the gas valves and the gas train stabiliser. With the burner operating at maximum output:

- install a pressure gauge downstream of the gas train stabiliser (for example at the gas pressure test point on the burner combustion head);
- choke slowly the manual gas cock until the pressure gauge detects a decrease in the pressure read of about 0.1 kPa (1 mbar). In this phase, verify the CO value which must always be less than 100 mg/kWh (93 ppm).
- Increase the adjustment of the gas pressure switch until it intervenes, causing the burner shutdown;
- remove the pressure gauge and close the cock of the gas pressure test point used for the measurement;
- open completely the manual gas cock.



1 kPa = 10 mbar

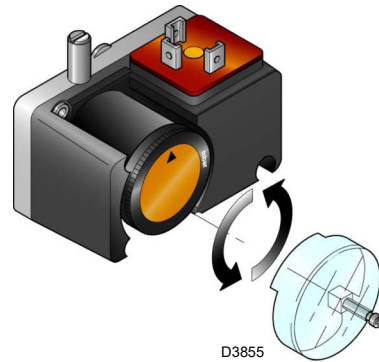

Fig. 30

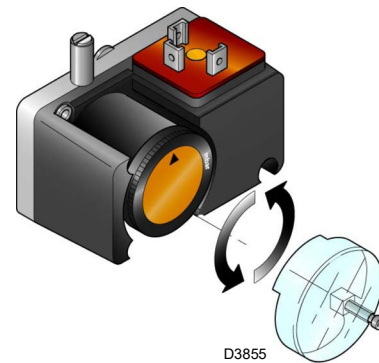

Fig. 31

5.5.4 PVP pressure switch kit

Adjust the pressure switch for the valve leak detection control device (PVP Kit) (Fig. 31), if present, according to the instructions supplied with the Kit itself.

5.6 Steady-state operation

Once the start-up cycle is completed, the servomotor command moves on to the thermostat/pressure switch that controls the pressure or the temperature in the boiler.

- If the temperature or the pressure is low the burner progressively increases the output as far as the MAX value.
- If the temperature or the pressure increases as far as the opening of the thermostat/pressure switch, the burner progressively reduces the output as far as the MIN value.

- The burner switches off when the request for heat is lower than the heat supplied by the burner at MIN output.
- The thermostat/pressure switch TL opens and the flame control carries out the switching off phase.
- The damper closes completely to reduce thermal dispersions to a minimum.

5.7 Ignition failure

If the burner does not switch on, there is a lockout within 3s of the electrical supply reaching the gas valve.

It may be that the gas does not arrive at the combustion head within the safety time of 3 s.

In this case, increase gas delivery upon ignition.

The arrival of the gas at the pipe coupling is shown on the pressure gauge of Fig. 34 at page 36.



In the event of a burner lockout, more than two consecutive burner reset operations could cause damage to the installation. On the third lockout, contact the Aftersales Service.



If further lockouts or burner faults occur, interventions must only be made by qualified, authorised personnel (as indicated in this manual, and in compliance with the laws and regulations currently in force).

5.8 Burner flame goes out during operation

If the flame accidentally goes out during operation, the flame control carries out a recycle (i.e. it repeats the start-up phase once, and makes a further ignition attempt).





If the flame is still absent, the flame control goes into lockout.

5.9 Stopping of the burner

The burner can be stopped by:

- intervening on the disconnecting switch of the electrical supply line, located on the boiler panel;
- working on the switch “**0-AUTO**” of Fig. 27 at page 30;
- removing the transparent protection that covers the Operator Panel.

5.10 Final checks (with burner operating)

<ul style="list-style-type: none"> ➤ Open the thermostat/pressure switch TL ➤ Open the thermostat/pressure switch TS 		The burner must stop
<ul style="list-style-type: none"> ➤ Turn the gas maximum pressure switch knob to the minimum end of scale position ➤ Turn the air pressure switch to the maximum end of scale position. 		The burner must stop in lockout
<ul style="list-style-type: none"> ➤ Disconnect the minimum gas pressure switch connector. 		The burner must not start
<ul style="list-style-type: none"> ➤ Disconnect the ionisation probe wire 		The burner must stop in lockout due to firing failure

Tab. P



Make sure that the mechanical locking systems on the various adjustment devices are fully tightened.

5.11 Description of O₂ trim control (optional)

A special feature of the LMV52... is control of the residual O₂ content to increase the boiler's efficiency. The LMV52... uses a QGO20..., an external PLL52..., and the standard components of the LMV51... The PLL52... is a detached measuring module for the O₂ sensor and for 2 temperature sensors (Pt1000 / LG-Ni1000). The module communicates with the LMV52... via CAN bus.

The following generic diagram shows the system (Fig. 32).

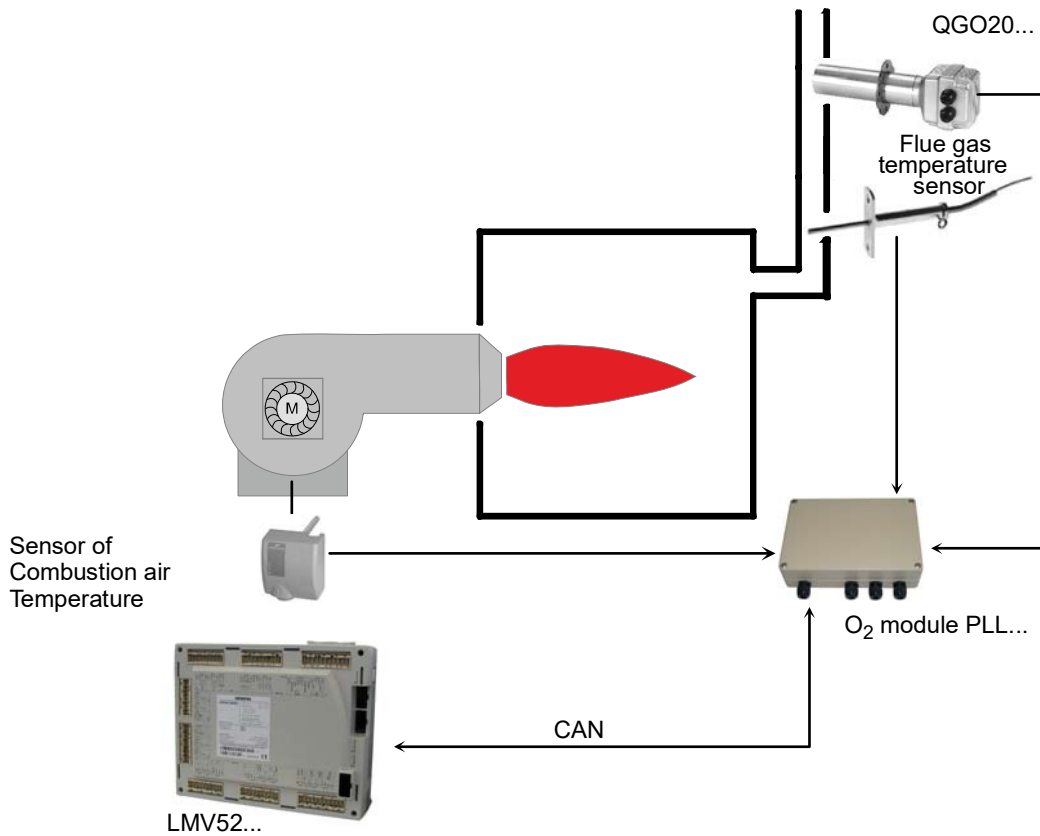

S9903

Fig. 32

5.11.1 Operating principle of O₂ trim control

The residual O₂ control system reduces the amount of combustion air depending on the control deviation (O₂ setpoint minus actual of O₂). The amount of combustion air is normally influenced by several actuators and, if used, by a VSD. **Reduction of the amount of air is reached by reducing the «air rate» of the air-regulating actuators.**

For that purpose, the damper positions of these actuators are calculated from some other load point on the ratio control curves. Hence, due to the parameterized ratio control curves, the air-regulating actuators are in a fixed relation to one another.

O₂ trim control is supported by **precontrol**. **Precontrol calculates the air rate reduction such that changes in burner load do not require the O₂ trim controller to interfere.** Consideration is given to a number of measured values that are ascertained when the burner is set. This means that the controller only becomes active when environmental conditions (temperature, pressure) change, and not when the burner load changes.

For a correct system operation, it may be necessary to install an additional transformer (AGG5 ..), depending on the number of actuators / modules or cables length. Consult the documentation / wiring diagram of the burner.



The installation and setting of the system must be carried out by qualified personnel, as indicated in the specific documentation of the device.

6 Maintenance

6.1 Notes on safety for the maintenance

The periodic maintenance is essential for the good operation, safety, yield and duration of the burner.

It allows you to reduce consumption and polluting emissions and to keep the product in a reliable state over time.



The maintenance interventions and the calibration of the burner must only be carried out by qualified, authorised personnel, in accordance with the contents of this manual and in compliance with the standards and regulations of current laws.

Before carrying out any maintenance, cleaning or checking operations:



Disconnect the electrical supply from the burner by means of the main system switch.



Close the fuel interception tap.



Wait for the components in contact with heat sources to cool down completely.

6.2 Maintenance programme

6.2.1 Maintenance frequency



The gas combustion system should be checked at least once a year by a representative of the manufacturer or another specialised technician.

6.2.2 Safety test - with gas feeding closed

For its safe commissioning it is very important to make sure that the electrical wiring has been carried out correctly between the gas valves and the burner.

To this end, after checking that the connections have been made in conformity with the burner's wiring diagram, a starting cycle should be carried out with the gas tap closed (dry test).

- 1 The manual gas valve should be closed with the locking/releasing device ("lock-out / tag out" procedure).
- 2 Make sure the limit electric contacts of the burner close
- 3 Make sure the contact of the minimum gas pressure switch closes
- 4 Proceed with a tentative start up of the burner.

The starting cycle should occur with the following phases:

- Starting the fan motor for pre-purging
- Carrying out the gas valve leak detection control, if applicable
- Completing the pre-purging
- Reaching the ignition point
- Power supply of the ignition transformer
- Power supply the gas valves.

Since the gas is closed, the burner will not be able to start and its flame control will stop or go into a safety lockout.

The effective supplying of the gas valves can be checked with the insertion of a tester; some valves are fitted with light signals (or closure/opening position indicators) that are activated when the electrical supply arrives.



IF THE ELECTRICAL SUPPLY OF THE GAS VALVES OCCURS AT AN UNEXPECTED MOMENT, DO NOT OPEN THE MANUAL VALVE, DISCONNECT THE ELECTRICAL SUPPLY, CHECK THE WIRING; CORRECT THE ERRORS AND CARRY OUT THE ENTIRE TEST AGAIN.

6.2.3 Checking and cleaning



The operator must use the required equipment during maintenance.

Combustion

The optimum calibration of the burner requires an analysis of the flue gases. Significant differences with respect to the previous measurements indicate the points where more care should be exercised during maintenance.

Combustion head

Open the burner and make sure that all the components of the combustion head are undamaged, not deformed due to high temperature, free of ambient dirt or dust, free of rusted materials and adequately positioned.

Make sure that the gas outlet holes for the start-up, on the combustion head distributor, are free of dirt or rust deposits. If in doubt, disassemble the elbow.

Fan

Check to make sure that no dust has accumulated inside the fan or on its blades, as this condition will cause a reduction in the air flow rate and provoke polluting combustion.

Burner

Clean the outside of the burner.

Gas leaks

Make sure that there are no gas leaks on the pipes between the gas meter and the burner.

Gas filter

Replace the gas filter when it is dirty.

Flame inspection window

Clean the glass of the flame inspection window.

Boiler

Clean the boiler as indicated in its accompanying instructions in order to maintain all the original combustion characteristics intact, especially the flue gas temperature and combustion chamber pressure.

Combustion

If the combustion values found at the start of the intervention do not satisfy current standards or anyway indicate a poor state of combustion (consult the table below), contact the Technical Assistance Service for the necessary adjustments.

EN 676		Air excess			
		Max. output $\lambda \leq 1.2$		Min. output $\lambda \leq 1.3$	
GAS	CO ₂ theoretic al max. 0% O ₂	CO ₂ % Calibration		CO	NO _x
		$\lambda = 1.2$	$\lambda = 1.3$	mg/kWh	mg/kWh
G 20	11.7	9.7	9.0	≤ 100	≤ 170
G 25	11.5	9.5	8.8	≤ 100	≤ 170
G 30	14.0	11.6	10.7	≤ 100	≤ 230
G 31	13.7	11.4	10.5	≤ 100	≤ 230

Tab. Q

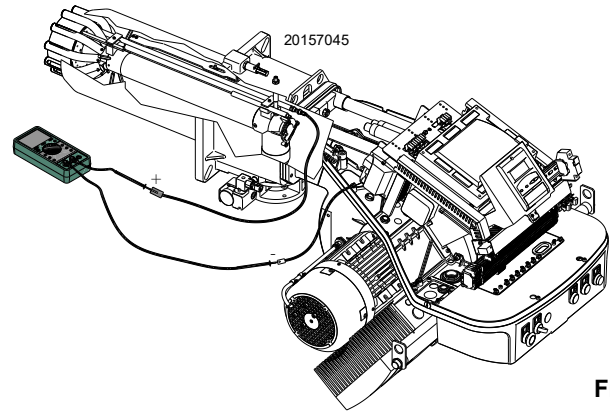

Fig. 33

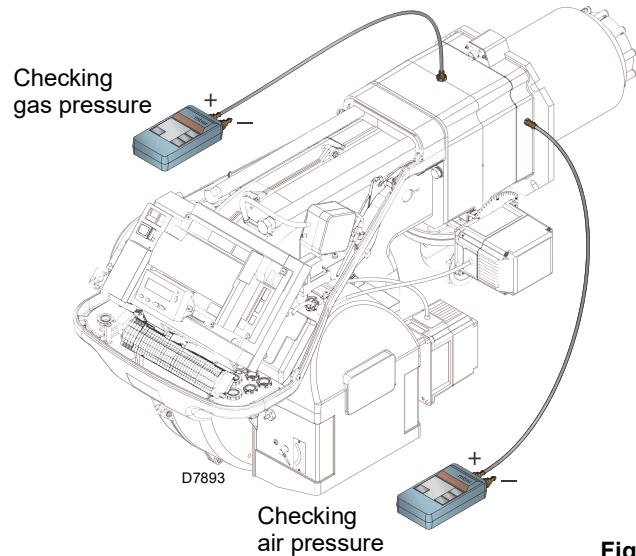

Fig. 34

6.2.4 Measuring the ionisation current

The burner is fitted with an ionisation system to check that a flame is present.

The minimum current for flame control operation is 4 µA.

The burner provides a much higher current, so controls are not normally required.

However, if it is necessary to measure the ionisation current, disconnect the plug-socket on the ionisation probe cable and insert a direct current microammeter with a base scale of 100 µA - see Fig. 33.



Carefully check the polarities!

6.2.5 Checking the air and gas pressure on the combustion head

To carry out this operation a pressure gauge must be used to measure the air and gas pressure at the combustion head, as shown in Fig. 34.

6.2.6 Safety components

The safety components should be replaced at the end of their life cycle indicated in Tab. R.

The specified life cycles do not refer to the warranty terms indicated in the delivery or payment conditions.

Safety component	Life cycle
Flame control	10 years or 250,000 operation cycles
Flame sensor	10 years or 250,000 operation cycles
Gas valves (solenoid)	10 years or 250,000 operation cycles
Pressure switches	10 years or 250,000 operation cycles
Pressure adjuster	15 years
Servomotor (electronic cam) (if present)	10 years or 250,000 operation cycles
Oil valve (solenoid) (if present)	10 years or 250,000 operation cycles
Oil regulator (if present)	10 years or 250,000 operation cycles
Oil pipes/ couplings (metallic) (if present)	10 years
Fan impeller	10 years or 500,000 start-ups

Tab. R

6.3 Opening the burner



Disconnect the electrical supply from the burner by means of the main system switch.



Turn off the fuel interception tap.



Wait for the components in contact with heat sources to cool down completely.

- Loosen the 4 screws 1)(Fig. 35) and remove the hood 2);
- assemble the two extensions supplied on the slide bars 4) and tighten the screws 7);
- disconnect the socket from the maximum gas pressure switch;
- remove the screws 3) and move the burner backwards by about 100 mm on the slide bars 4);
- disconnect the probe and electrode leads and then pull the burner fully back.

At this point it is possible to extract the inner part 5) after having removed the screw 6).

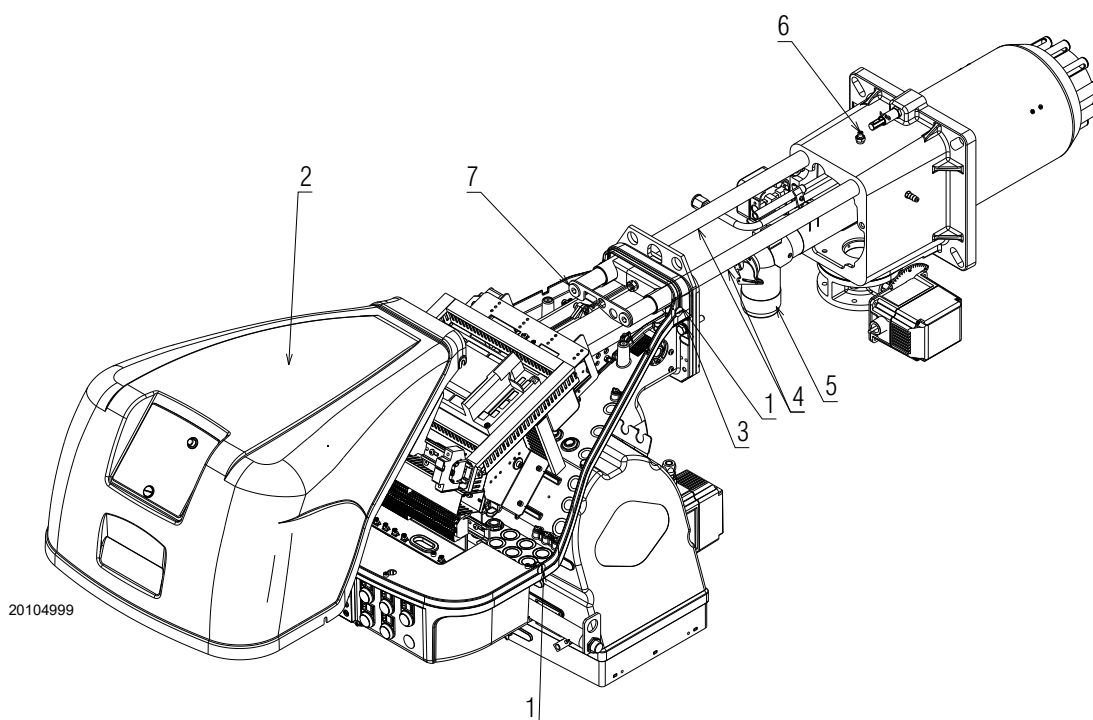

Fig. 35

6.4 Closing the burner

- Push the burner up to approximately 100 mm from the pipe coupling;
- reconnect the cables and slide in the burner until it comes to a stop;
- connect the socket of the maximum gas pressure switch;
- replace the screws 3)(Fig. 35) and carefully pull the probe and electrode cables outwards until they are slightly taut;
- disassemble the two extensions from the guides 4).



After carrying out maintenance, cleaning or checking operations, reassemble the hood and all the safety and protection devices of the burner.

A Appendix - Accessories**Spacer kit**

Burner	Thickness (mm)	Code
RS 160-200/E O ₂ BLU	135	3000722

Continuous purging kit

Burner	Code
RS 160-200/E O ₂ BLU	3010094

Soundproofing chamber kit

Burner	Type	dB(A)	Code
RS 160-200/E O ₂ BLU	C4/5	10	3010404

kit for modulating operation

With the modulating operation, the burner continually adapts the power to the heat request, ensuring a high level of stability for the parameter controlled: temperature or pressure.

Parameter to be checked		Probe	
	Adjustment field	Type	Code
Temperature	- 100 ÷ 500° C	PT 100	3010110
Pressure	0 ÷ 2.5 bar	4 ÷ 20 mA	3010213
	0 ÷ 16 bar	4 ÷ 20 mA	3010214
	0 ÷ 25 bar	4 ÷ 20 mA	3090873

Head kit for flame inversion boiler

Burner	Code
RS 160/E O ₂ BLU	3010249
RS 200/E O ₂ BLU	20035848

Gas flange DN80 kit

Burner	Code
RS 160-200/E O ₂ BLU	3010439

Kit PVP (Pressure Valve Proving) - supplied with the burner

Bruciatore	Tipo rampa	Codice
RS 160-200/E O ₂ BLU	MB - MBC - CB	3010344

Software interface kit

Burner	Code
RS 160-200/E O ₂ BLU	3010388

Oxygen control kit

Burner	Code
RS 160-200/E O ₂ BLU	20045187

Kit efficiency with oxygen control kit

Burner	Code
RS 160-200/E O ₂ BLU	3010377

Kit 2nd transformer

Burner	Code
RS 160-200/E O ₂ BLU	20044117

Gas trains in compliance with EN 676

Please refer to manual.



ATTENZIONE

The installer is responsible for the addition of any safety device not foreseen in this manual.

B Appendix - Electrical panel layout

1	Index of layouts
2	Indication of references
3	Layout of unifilar output
4	Operational layout LMV52...
5	Operational layout LMV52...
6	Operational layout LMV52...
7	Operational layout LMV52...
8	Operational layout LMV52...
9	Operational layout LMV52...
10	Operational layout LMV52...
11	Electrical connection set by installer
11B	Electrical connection set by installer
12	Electrical connection set by installer
13	Electrical connection set by installer

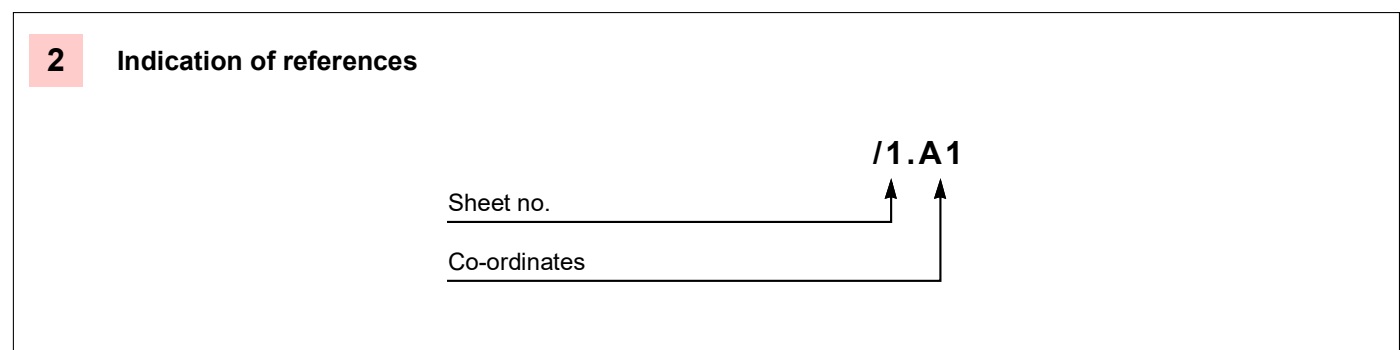

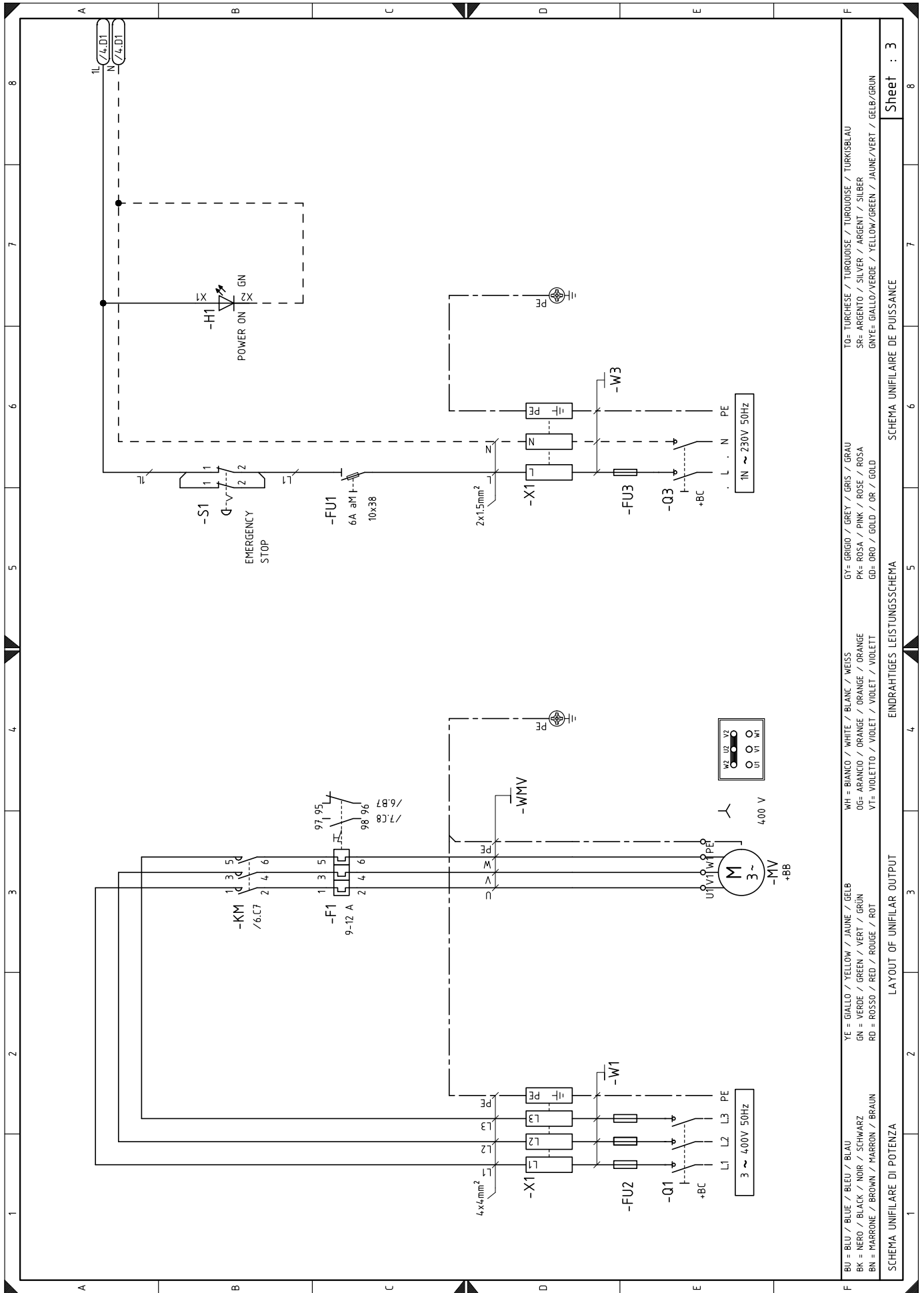

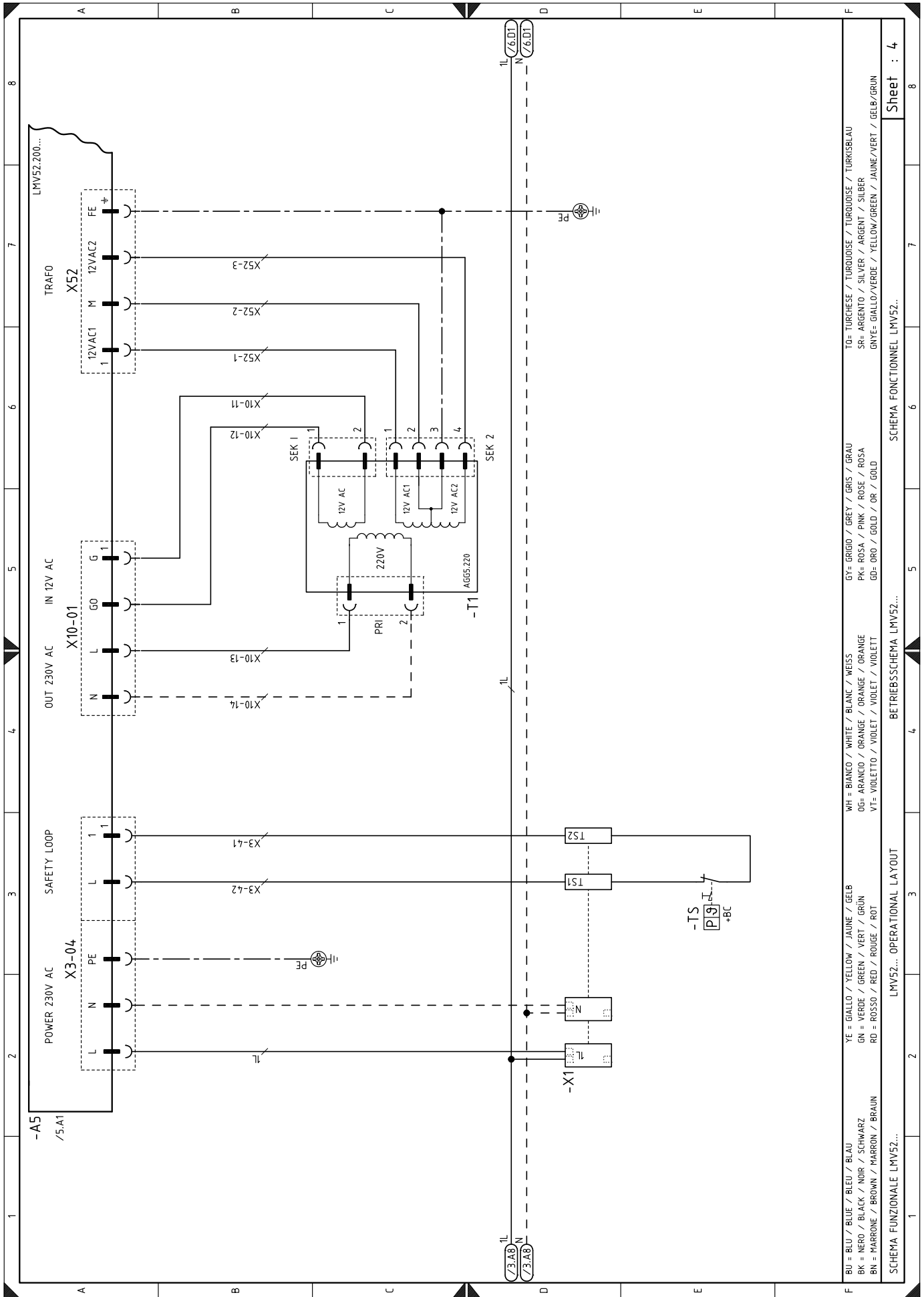

BU = BLU / BLUE / BLEU / BLAU
 BK = NERO / BLACK / NOIR / SCHWARZ
 BN = MARRONE / BROWN / MARRON / BRAUN
 YE = GIALLO / YELLOW / JAUNE / GELB
 GN = VERDE / GREEN / VERT / GRÜN
 RD = ROSSO / RED / ROUGE / ROT
 WH = BIANCO / WHITE / BLANC / WEISS
 OG = ARANCIO / ORANGE / ORANGE / ORANGE
 VT = VIOLETTA / VIOLET / VIOLET / VIOLETT
 GY = GRIGIO / GREY / GRIS / GRAU
 PK = ROSA / PINK / ROSE / ROSA
 GD = ORO / GOLD / OR / GOLD
 TO = TURCHESE / TURQUOISE / TURQUOISE / TURKISBLAU
 SR = ARGENTO / SILVER / ARGENT / SILBER
 GNYE = GIALLO/VERDE / YELLOW/GREEN / JAUNE/VERT / GELB/GRÜN

Sheet : 4

SCHEMA FONCTIONNEL LMV52...

BETRIEBSSCHEMA LMV52...

OPERATIONAL LAYOUT

LMV52... OPERATIONAL LAYOUT

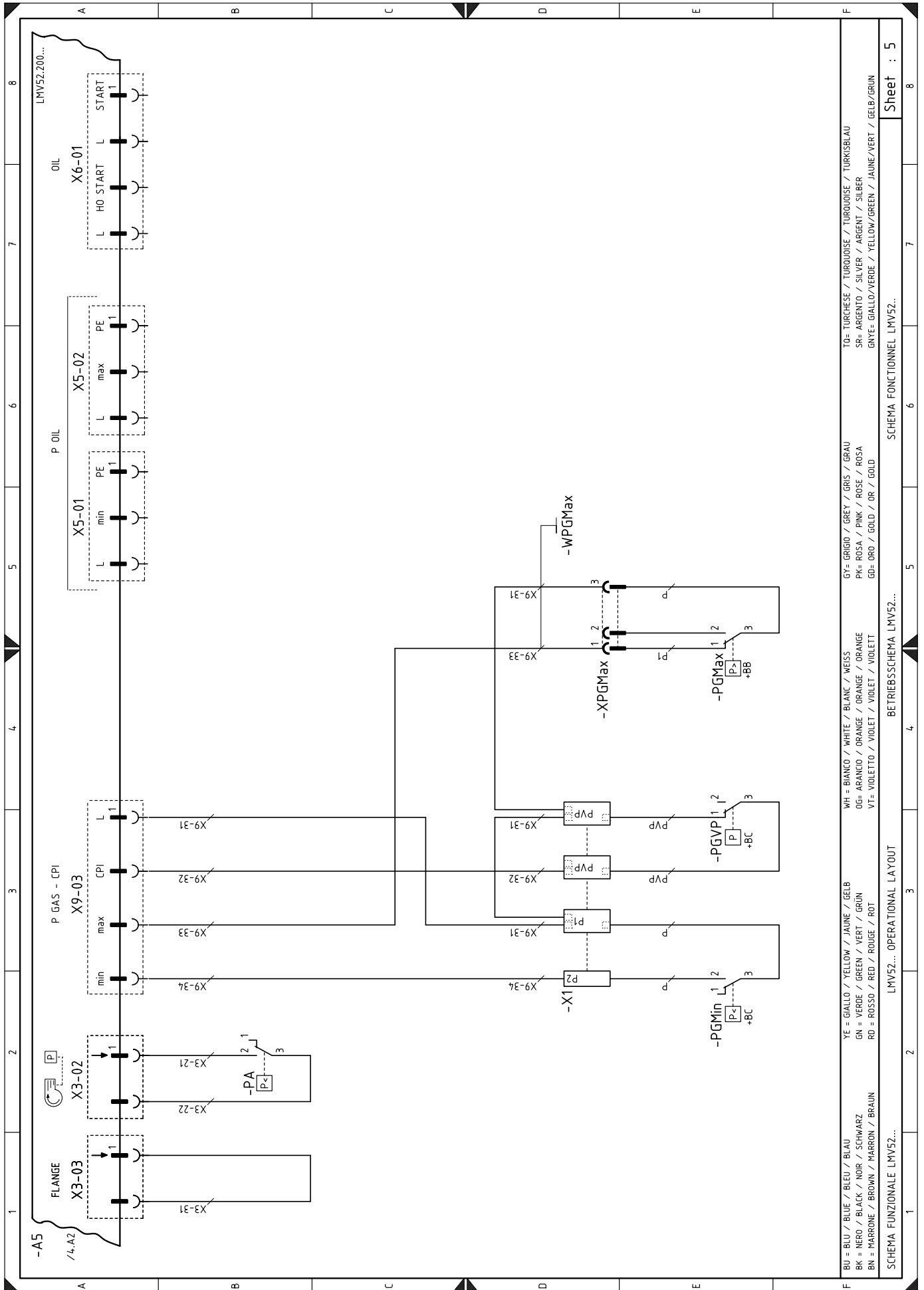

BU = BLU / BLUE / BLEU / BLAU	YE = GIALLO / YELLOW / JAUNE / GELB	WH = BIANCO / WHITE / BLANC / WEISS	GY = GRIGIO / GREY / GRIS / GRAU	TO= TURCHESE / TURQUOISE / TURKOISE / TURKSBLAU
BK = NERO / BLACK / NOIR / SCHWARZ	GN = VERDE / GREEN / VERT / GRÜN	OG= ARANCIO / ORANGE / ORANGE / ORANGE	PK= ROSA / PINK / ROSE / ROSA	SR= ARGENTO / SILVER / ARGENT / SILBER
BN = MARRONE / BROWN / MARRON / BRAUN	RD = ROSSO / RED / ROUGE / ROT	VT= VIOLETTO / VIOLET / VIOLET / VIOLETT	GD= ORO / GOLD / OR / GOLD	GNYE= GIALLO/VERDE / YELLOW/GREEN / JAUNE/VERT / GELB/GRÜN
SCHEMA FUNZIONALE LMV52... OPERATIONAL LAYOUT				
LMV52... BETREIBSSCHEMA LMV52...				
SCHEMA FONCTIONNEL LMV52...				
				Sheet : 5

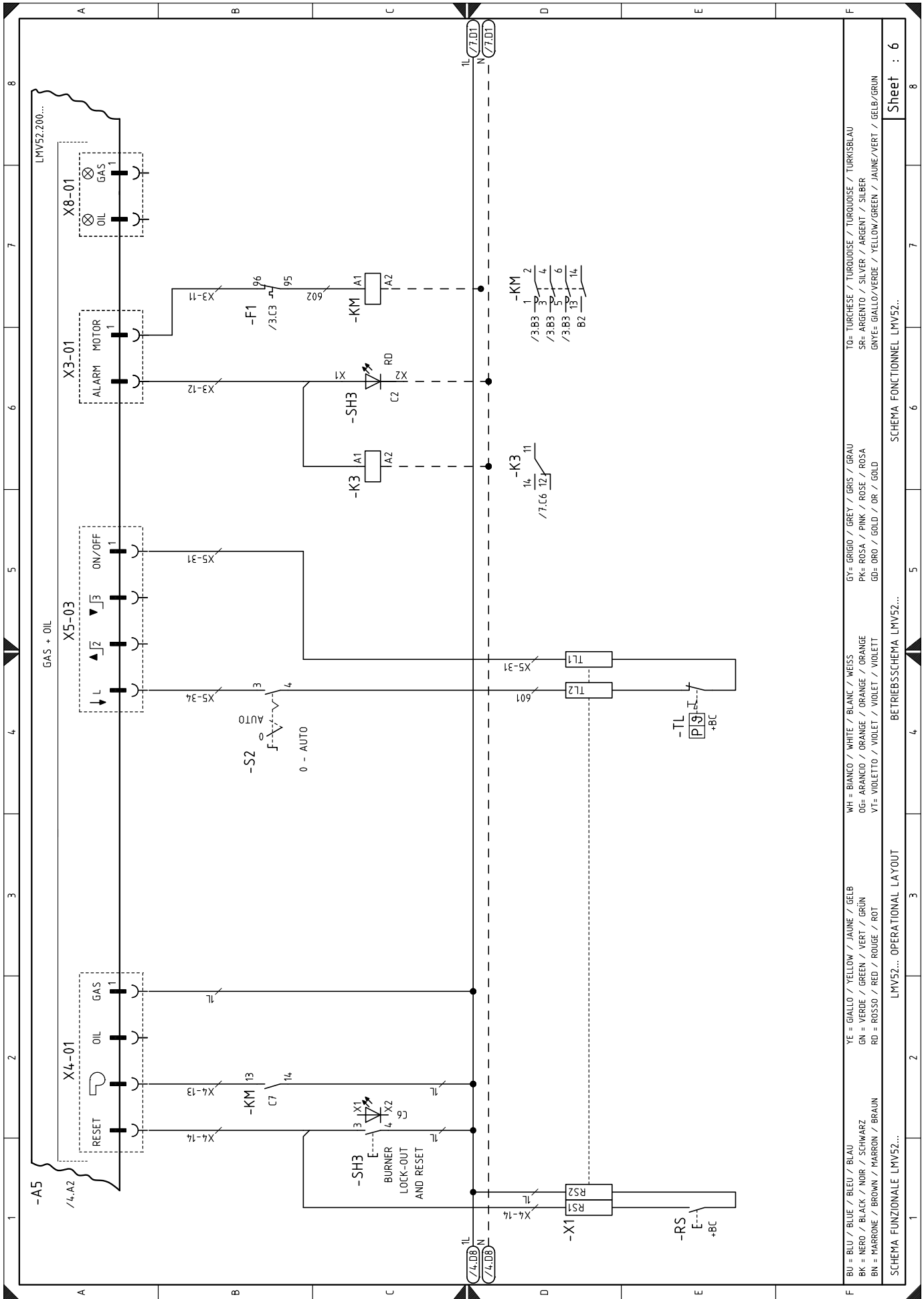

BU = BLU / BLUE / BLEU / BLAU	YE = GIALLO / YELLOW / JAUNE / GELB	WH = BIANCO / WHITE / BLANC / WEISS	GY = GRIGIO / GREY / GRIS / GRAU	TO = TURCHESE / TURQUOISE / TURKOISE / TURKISBLAU			
BK = NERO / BLACK / NOIR / SCHWARZ	GN = VERDE / GREEN / VERT / GRÜN	OG = ARANCIO / ORANGE / ORANGE / ORANGE	PK = ROSA / PINK / ROSE / ROSA	SR = ARGENTO / SILVER / ARGENT / SILBER			
BN = MARRONE / BROWN / MARRON / BRAUN	RD = ROSSO / RED / ROUGE / ROT	VT = VIOLETTA / VIOLET / VIOLET / VIOLETT	GD = ORO / GOLD / OR / GOLD	GRYE = GIALLO/VERDE / YELLOW/GREEN / JAUNE/VERT / GELB/GRÜN			
SCHEMA FUNZIONALE LMV52...			SCHEMA FONCTIONNEL LMV52...				
LMV52... OPERATIONAL LAYOUT			BETRIEBSSCHEMA LMV52...				
1	2	3	4	5	6	7	8
Sheet : 6							8

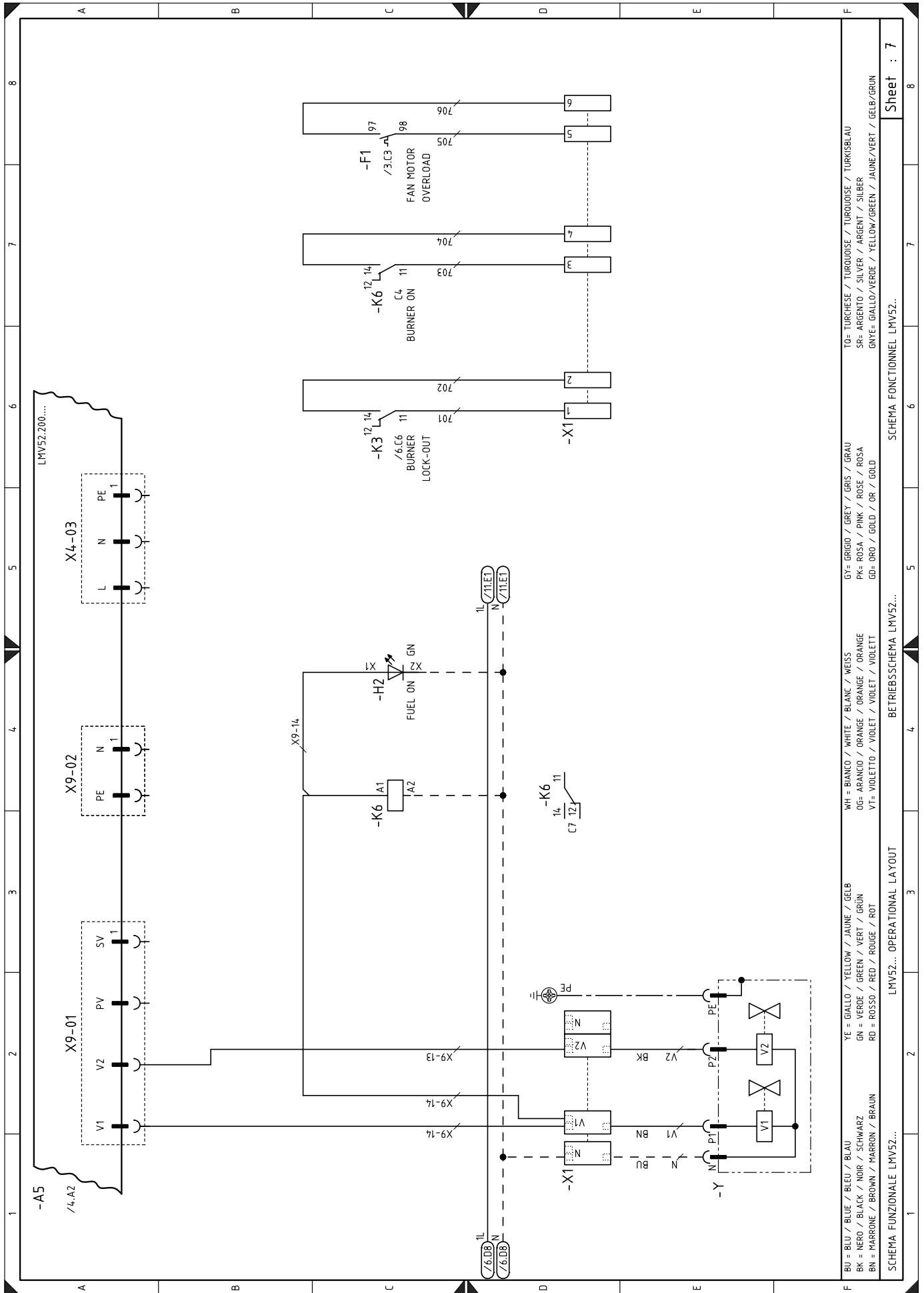

BU = BLU / BLUE / BLEU / BLAU	YE = GIALLO / YELLOW / JAUNE / GELB	WH = BIANCO / WHITE / BLANC / WEISS	GY = GRIGIO / GREY / GRIS / GRAU	TO= TURCHESE / TURQUOISE / TURKOISE / TURKISBLAU
BK = NERO / BLACK / NOIR / SCHWARZ	GN = VERDE / GREEN / VERT / GRÜN	OG= ARANCIO / ORANGE / ORANGE / ORANGE	PK= ROSA / PINK / ROSE / ROSA	SR= ARGENTO / SILVER / ARGENT / SILBER
BN = MARRONE / BROWN / MARRON / BRAUN	RD = ROSSO / RED / ROUGE / ROT	VI= VIOLETTA / VIOLET / VIOLET / VIOLETT	GD= ORO / GOLD / OR / GOLD	GNTE= GIALLO/VERDE / YELLOW/GREEN / JAUNE/VERT / GELB/GRÜN

Sheet : 7

SCHEMA FONCTIONNEL LMV52...

BETRIEBSSCHEMA LMV52...

LMV52... OPERATIONAL LAYOUT

SCHEMA FUNZIONALE LMV52...

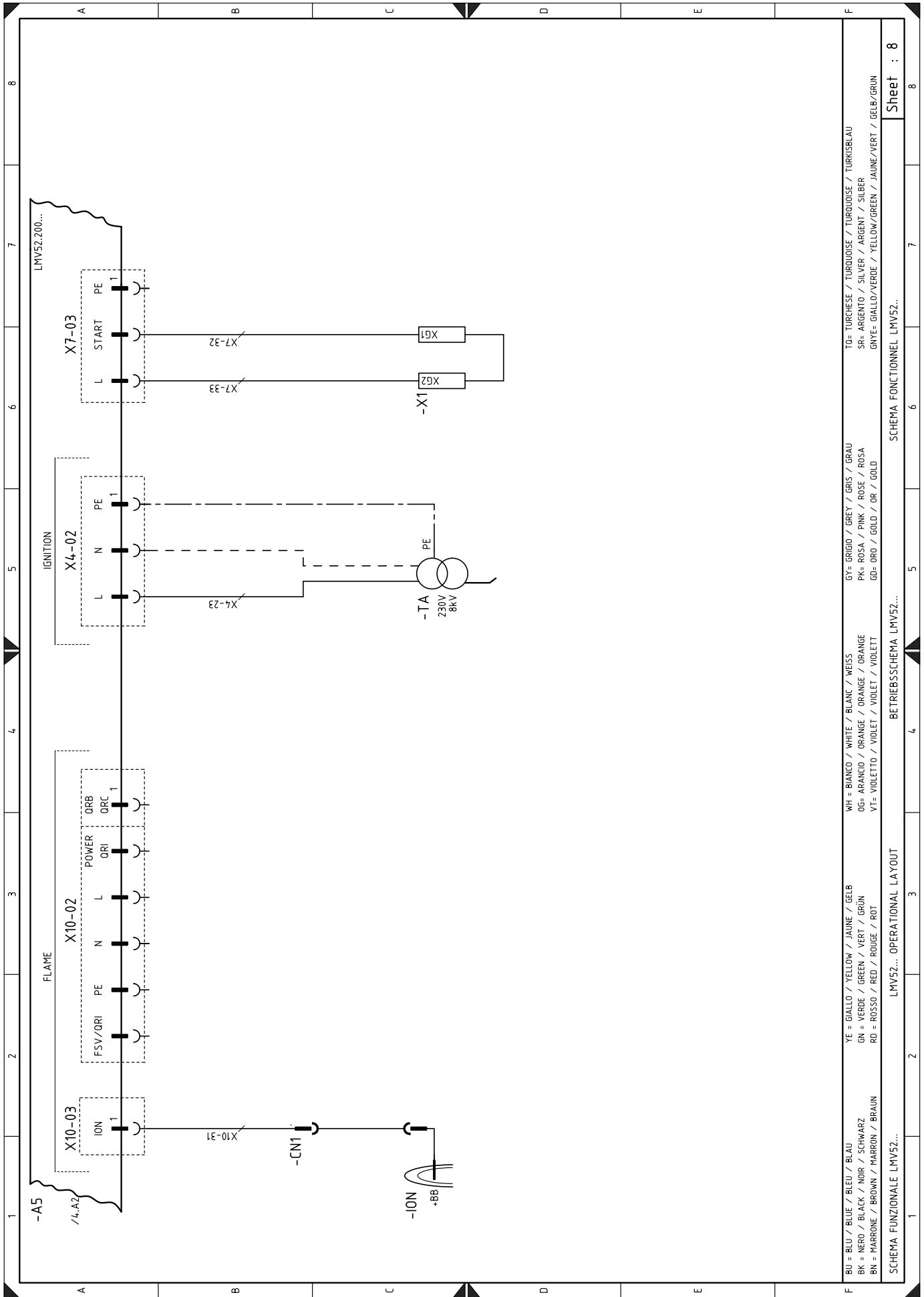

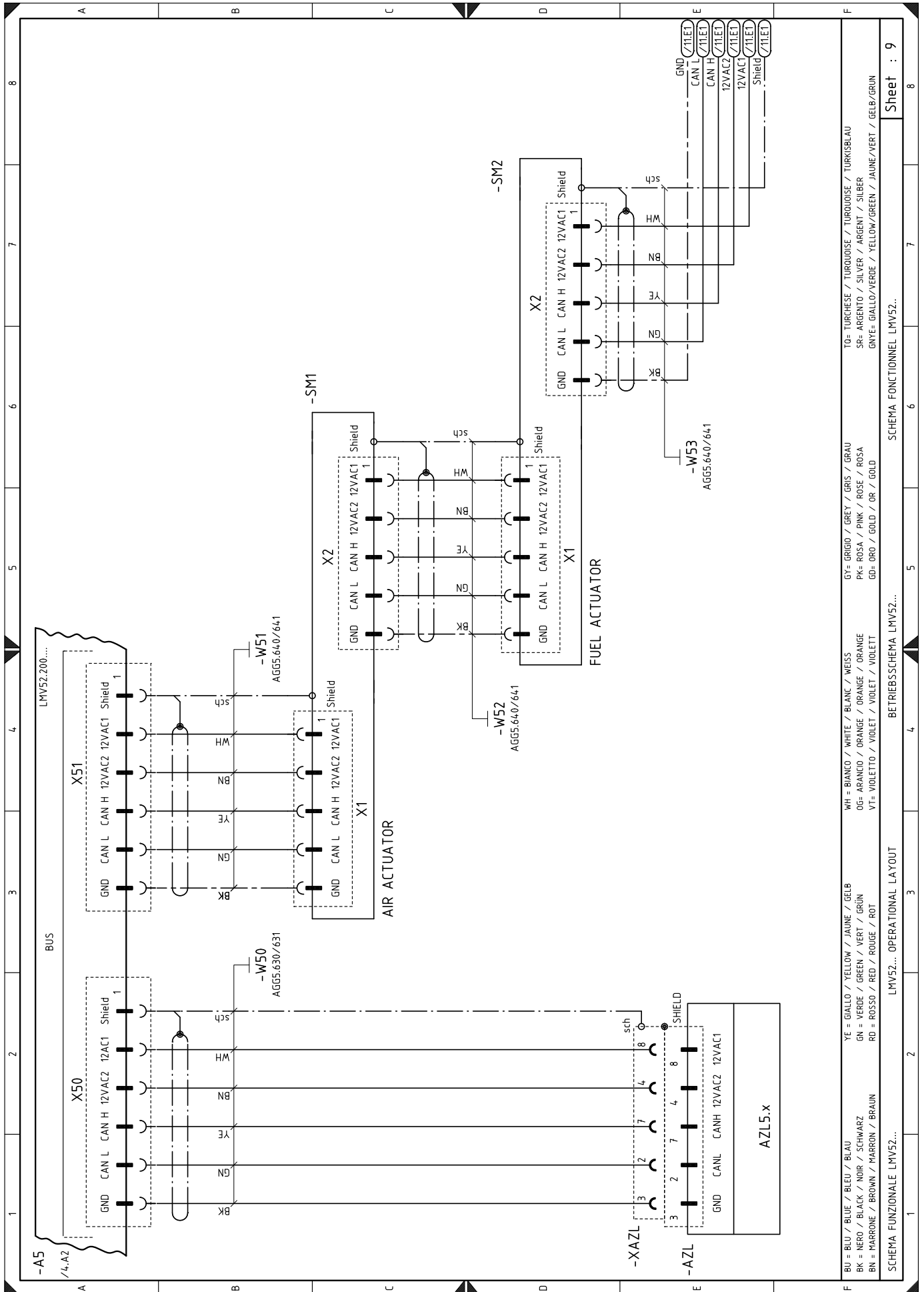

Sheet : 9

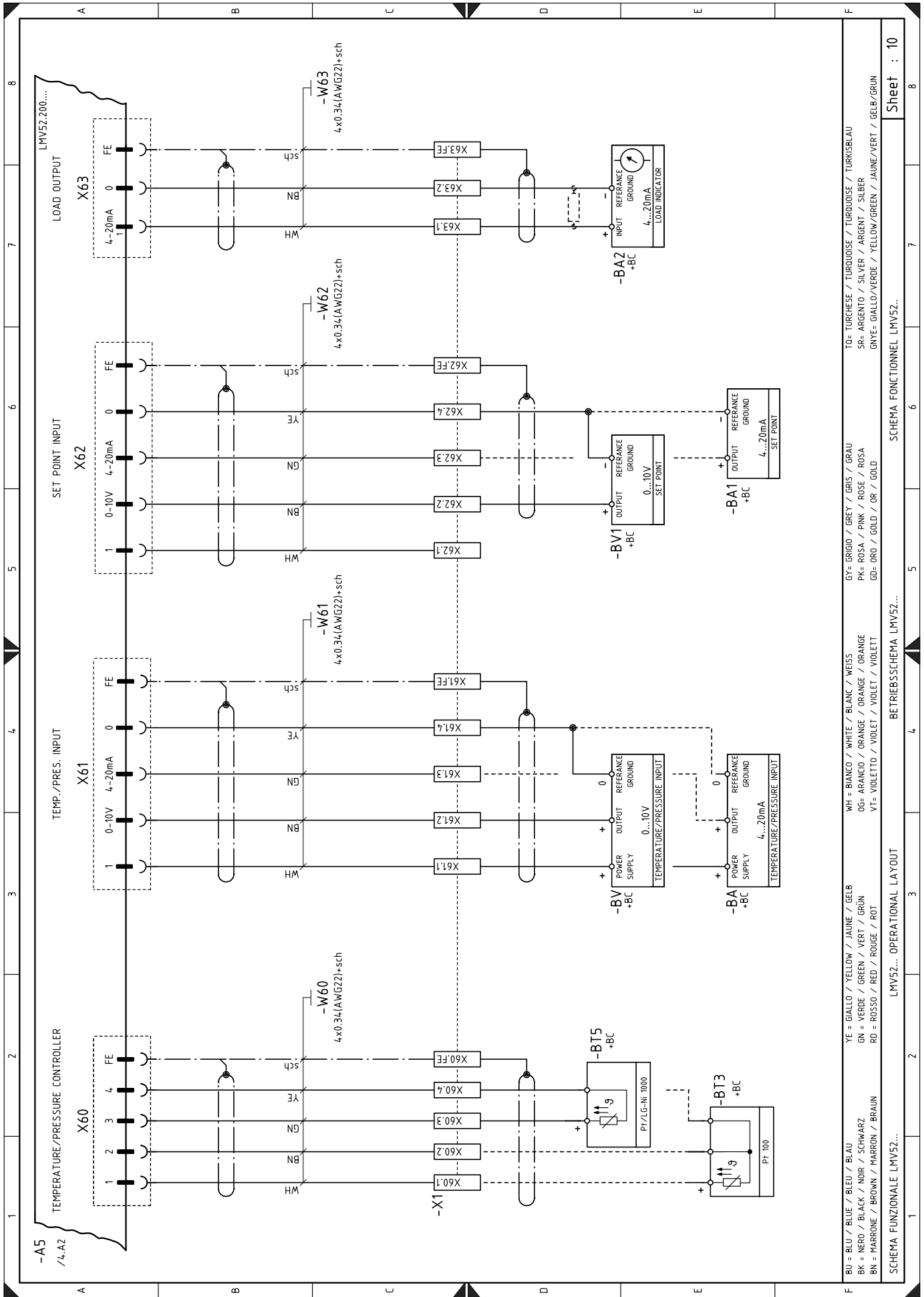

TO= TURCHESE / TURQUOISE / TURQUOISE / TURKISBLAU
 SR= ARGENTO / SILVER / ARGENT / SILBER
 GNYE= GIALLO/VERDE / YELLOW/GREEN / JAUNE/VERT / GELB/GRÜN

G7= GRIGIO / GREY / GRIS / GRAU
 PK= ROSA / PINK / ROSE / ROSA
 GD= ORO / GOLD / OR / GOLD

WH = BIANCO / WHITE / BLANC / WEISS
 OG= ARANCIO / ORANGE / ORANGE / ORANGE
 VT= VIOLETTA / VIOLET / VIOLET / VIOLETT

YE = GIALLO / YELLOW / JAUNE / GELB
 GN = VERDE / GREEN / VERT / GRÜN
 RD = ROSSO / RED / ROUGE / ROT

BU = BLU / BLUE / BLEU / BLAU
 BK = NERO / BLACK / NOIR / SCHWARZ
 BN = MARRONE / BROWN / MARRON / BRAUN

SCHEMA FUNZIONALE LMV52...
 SCHEMA FONCTIONNEL LMV52...
 SCHEMA FUNCTIONNEL LMV52...

LMV52... OPERATIONAL LAYOUT
 BETRIEBSSCHEMA LMV52...
 SCHEMA FONCTIONNEL LMV52...

Sheet : 10

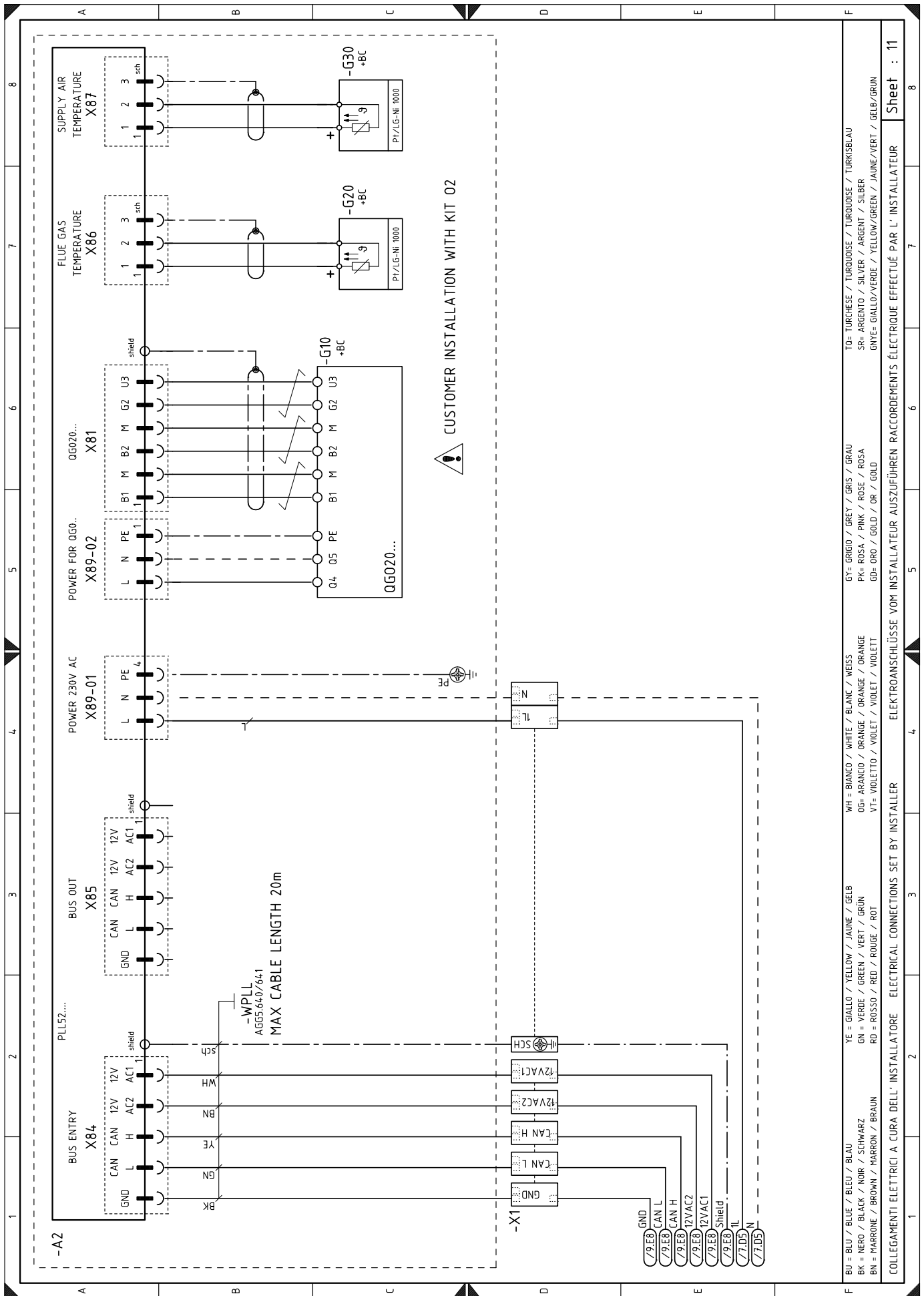

BU = BLU / BLUE / BLEU / BLAU	YE = GIALLO / YELLOW / JAUNE / GELB	WH = BIANCO / WHITE / BLANC / WEISS	OG = ARANCIO / ORANGE / ORANGE / ORANGE	VI = VIOLETTO / VIOLET / VIOLET / VIOLETT	TO = TURCHESE / TURQUOISE / TURQUOISE / TURKISBLAU
BK = NERO / BLACK / NOIR / SCHWARZ	GN = VERDE / GREEN / VERT / GRÜN	OG = ARANCIO / ORANGE / ORANGE / ORANGE	VI = VIOLETTO / VIOLET / VIOLET / VIOLETT	SR = ARGENTO / SILVER / ARGENT / SILBER	SR = ARGENTO / SILVER / ARGENT / SILBER
BN = MARRONE / BROWN / MARRON / BRAUN	RD = ROSSO / RED / ROUGE / ROT	WH = BIANCO / WHITE / BLANC / WEISS	OG = ARANCIO / ORANGE / ORANGE / ORANGE	GD = ORO / GOLD / OR / GOLD	GNTE = GIALLO/VERDE / YELLOW/GREEN / JAUNE/VERT / GELB/GRÜN

Sheet : 11

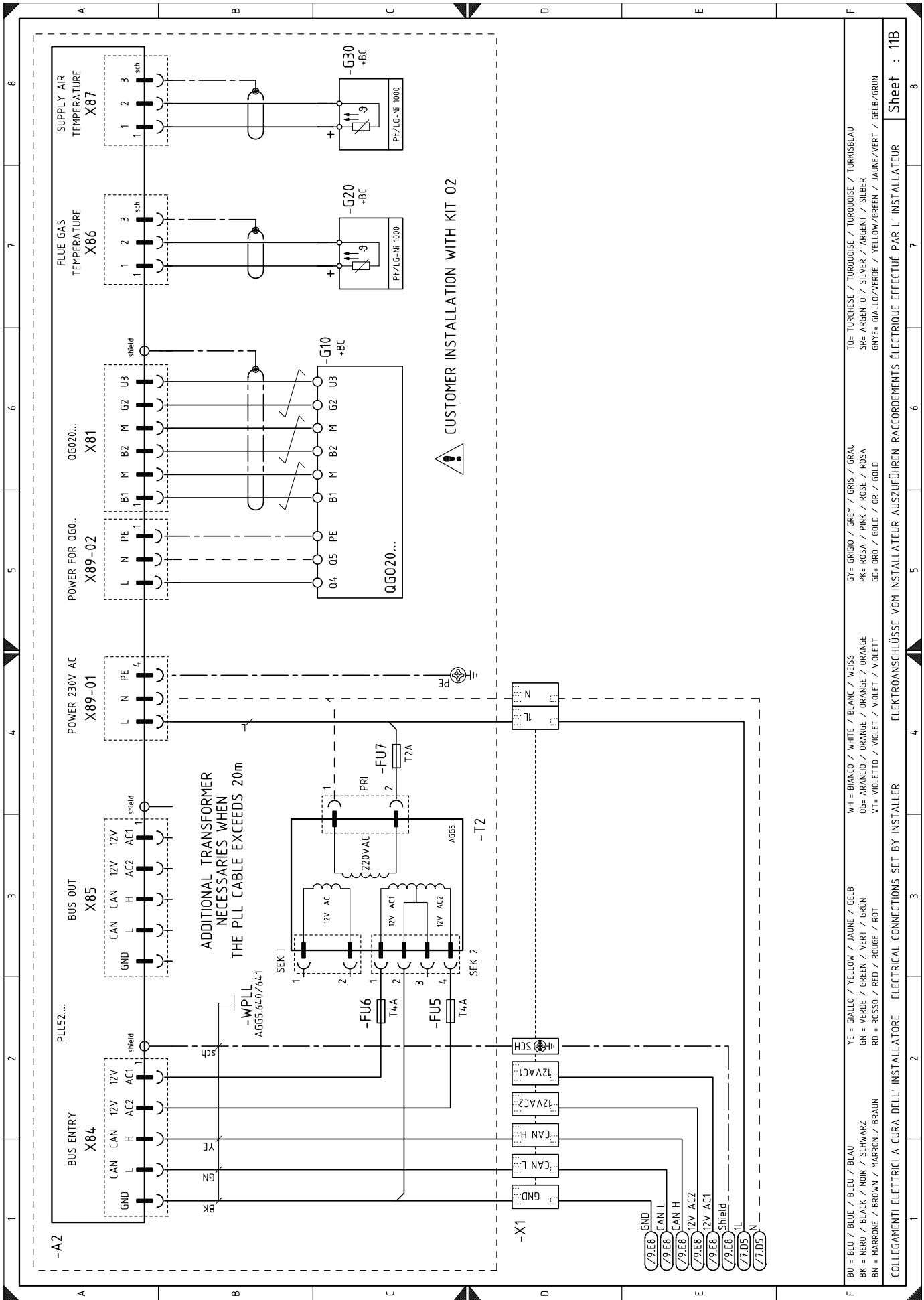

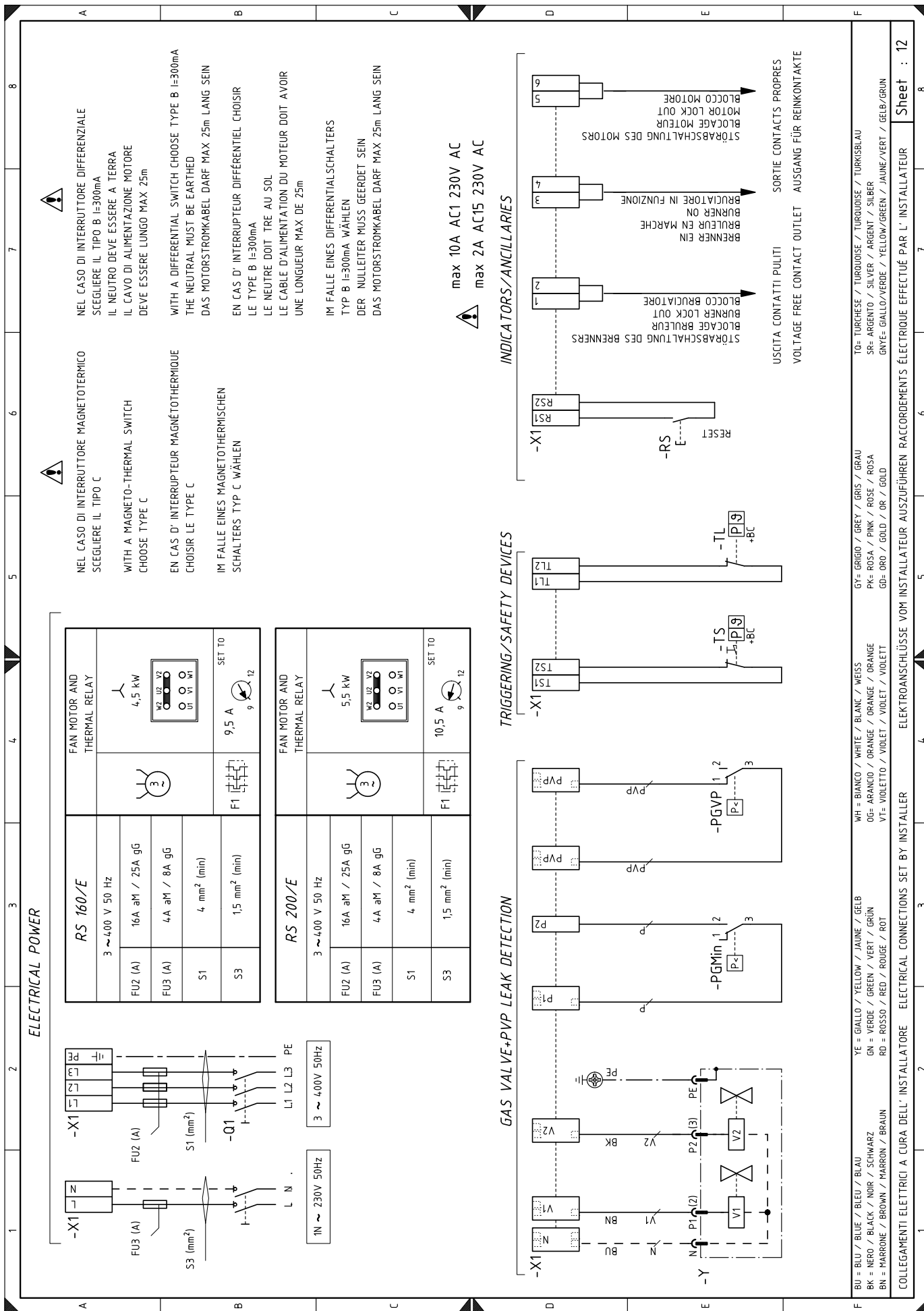

Wiring layout key

A2	O2 module - PLL type
A5	Flame control for the air/fuel ratio
AZL	Display flame control
BA2	Load indicator
BA3	Probe for external modulation 4...20mA
BA	Input in current DC 4...20 mA
BA1	Input in current DC 4...20 mA to modify remote set-point
+BB	Burner components
+BC	Boiler components
BP	Pressure probe
BP1	Pressure probe
BT3	Probe Pt100, 3 wires
BT4	Probe Pt100, 3 wires
BT5	PT/LG-Ni1000 probe
BV	Input in voltage DC 0...10V
BV1	Input in voltage DC 0...10V to modify remote setpoint
BV2	Probe for external modulation 2...10V
CN1	Ionisation probe connector
F1	Motor overload
FU1	Auxiliary fuse
FU2	Protection fuse for three-phase line
FU3	Protection fuse for one-phase line
G2	Motor speed sensor
G10	O2 sensor - QGO20 type
G20	Probe for combustion flue gases temperature control
G30	Probe for air temperature control
H1	Green indicator "POWER-ON"
H2	Green indicator "FUEL ON"
KM	Motor contactor
ION	Ionisation probe
MV	Fan motor
K3	K3 relay (free contact "BURNER LOCK-OUT")
K6	K6 relay (free contact "BURNER ON")
PA	Air pressure switch
PE	Burner earth
PGMax	Maximum gas pressure switch
PGMin	Minimum gas pressure switch
PGVP	Gas pressure switch for valve leak detection control device
Q1	Three-phase disconnecting switch
Q3	Single phase disconnecting switch
RS	Remote burner reset button
S1	"EMERGENCY STOP" button
S2	"0/AUTO" selector
SH3	Burner lock-out reset button and lock-out light signal
SM1	Air servomotor
SM2	Gas servomotor
TA	Ignition transformer
T1	Supply transformer of the flame control
T2	Additional transformer (optional, required for the O2 kit installation)
TL	Limit thermostat/pressure switch
TS	Safety thermostat/pressure switch
V1	V1 Valve
V2	V2 Valve
X1	Burner terminal strip
XPGMax	Maximum gas pressure switch connector
XAZL	Connector for flame control display
Y	Gas adjustment valve + gas safety valve

RIELLO

RIELLO S.p.A.
I-37045 Legnago (VR)
Tel.: +39.0442.630111
[http:// www.riello.it](http://www.riello.it)
[http:// www.riello.com](http://www.riello.com)