

7000 ACI PLUS

EN INSTALLATION, OPERATION AND MAINTENANCE MANUAL

RIELLO

RANGE

MODEL	CODE
RIELLO 7000 ACI 60 PLUS	20090056
RIELLO 7000 ACI 120 PLUS	20082450
RIELLO 7000 ACI 200 PLUS	20028093
RIELLO 7000 ACI 300 PLUS	20028094
RIELLO 7000 ACI 400 PLUS	20028095
RIELLO 7000 ACI 500 PLUS	20028096

ACCESSORIES

For a complete list of accessories and details of their compatibility, refer to the Catalogue.

Dear heating engineer,

We would like to congratulate you on having recommended a **RIELLO** buffer tank unit: a modern product that's capable of ensuring a high degree of reliability, efficiency, quality and safety. While your technical skills and knowledge will certainly be more than sufficient, this booklet contains all the information that we have deemed necessary for the device's correct and easy installation.

Thank you again, and keep up the good work,

RIELLO S.p.A.

CONFORMITY

RIELLO buffer tanks conform to EN standard 10025.

CONTENTS

GENERAL

1	General Safety Information	4
2	Precautions.	4
3	Description of the appliance	5
4	Identification	5
5	System layout	6
6	Technical specifications.	6
7	Water circuit	7
8	Location of sensors	8
9	Overall dimensions and water fittings.	9

INSTALLER

10	Unpacking the product	10
11	Handling.	10
12	Wall mounting	11
13	Place of installation	11
14	Installation in older systems and systems requiring modernisation	11

TECHNICAL ASSISTANCE SERVICE

15	Putting into service	12
16	Maintenance.	12
17	Clean the buffer tank	12
18	Recycling and disposal	13
19	Troubleshooting	13

END USER









20	Start-up	14
21	Temporary shutdown	14
22	Preparing for extended periods of disuse	14
23	External maintenance.	14

The following symbols are used in this manual:

 **CAUTION!** = Identifies actions that require caution and adequate preparation.









 **STOP!** = Identifies actions that you MUST NOT do.

1 GENERAL SAFETY INFORMATION

-  Check that the product is complete, undamaged and as ordered as soon as you receive it. Report any discrepancies or damage to the **RIELLO** dealer who sold it.
-  This product must be installed by a legally qualified heating engineer. On completion of the installation, the installer must issue the owner with a declaration of conformity confirming that the installation has been completed to the highest standards in compliance with the instructions provided by **RIELLO** in this instruction manual, and that it conforms to all applicable laws and standards.
-  This product must only be used for the purpose for which it is designed and made, as specified by **RIELLO**. **RIELLO** declines all responsibility, contractual or other, for damage to property or injury to persons or animals caused by improper installation, adjustment, maintenance or use.
-  The product must be serviced at least once a year. Servicing must be arranged in advance with the **RIELLO** Technical Assistance Service.
-  All servicing and repairs must be performed by a qualified heating engineer.
-  If water leaks from the storage cylinder, turn off the water supply and contact **RIELLO's** Technical Assistance Service or a qualified heating engineer immediately.
-  If the product is not going to be used for an extended period of time, contact the manufacturer's Technical Assistance Service to have at least the following operations performed:
 - Close the shut-off cocks for the domestic hot water circuit
 - Shut down the boiler connected to the storage cylinder as instructed in its own manual
 - Switch the storage cylinder OFF at the control panel (if fitted) and at the mains power switch
 - Drain the central heating circuit and domestic hot water circuit if there is any risk of freezing.
-  This instruction manual is an integral part of the product. It must be kept safe and must ALWAYS accompany the product, even if it is sold to another owner or transferred to another user or to another installation. If you lose this manual, order a replacement immediately. Keep the product purchase documents to be presented to the **RIELLO** authorised Technical Assistance Service to request a service call under warranty.
-  If the product is destined for use in a solar collector circuit, anti-freeze (propylene glycol, available separately) must be mixed with water in a percentage varying from 30% to 50% as instructed in the installation and maintenance manual for the **RIELLO** solar collectors.

2 PRECAUTIONS

The operation of any appliance that uses electrical power demands that a number of fundamental safety precautions be respected. In particular:

-  Never attempt to install the system without using suitable personal protection equipment and without following all applicable occupational safety standards.
-  Do not touch the product when barefoot or wet if it has any electrical accessories installed in it.
-  Never clean or service the storage cylinder without first turning the mains power switch OFF to disconnect all electrical accessories (if fitted) from the mains electricity supply.
-  Never pull, disconnect, or twist any electrical cables coming from the appliance even if it is disconnected from the mains electricity supply.
-  Do not expose the storage cylinder to the elements. It is not designed for use outdoors.
-  If solar plant pressure decreases, it is forbidden to top up with only water as there is a danger of freezing and overheating.
-  Do not use connections or safety devices or fittings (expansion vessels, pipes, insulation) that are not specifically designed and tested for use in solar water heating systems.
-  Do not allow children or infirm persons to operate the system unsupervised.
-  Do not dispose of packaging material into the environment, or leave it within the reach of children, since it can become a potential hazard. Dispose of packaging material in compliance with applicable legislation.

3 DESCRIPTION OF THE APPLIANCE

RIELLO 7000 ACI PLUS buffer tanks can be used in conjunction with chiller systems, solar panels, heat pumps and wood burning boilers but are not designed to produce domestic hot water. These buffer tanks can be connected in a variety of ways to maximise flexibility in system layout.

The most important design features of the product are:

- special tank design and shape for optimum performance in terms of stratification, heat exchange and replenishment time
- the provision of fittings at different heights for high and low temperature circuits
- CFC and HCFC free PEXL + Soft polyurethane insulation and an elegant external casing to reduce heat loss and improve efficiency

RIELLO 7000 ACI PLUS buffer tanks are easy to integrate in systems in which **RIELLO** boilers or other products act as auxiliary heat sources.

4 IDENTIFICATION

RIELLO 7000 ACI PLUS buffer tanks are identified by:

Mod. 60 – 120

Data plate

It indicates the technical and performance data.

RIELLO		RIELLO S.p.A. Via Ing.Pilade Rialto 7 37045 Legnago (VR) - ITALY		CE	
PUFFERSPEICHER STORAGE CYLINDER VOORRAADVAT					
Model		Seriennummer Serial number		067610E	
Kode Code	Baujahr Year	Boowjaar			
Speichermass Storage cylinder capacity					l
Accumulatiecapaciteit					
Max. Betriebsdruck Speicher Max. working pressure of cylinder					bar
Max. bedrijfsdruk accumulatie					
Max. Betriebstemperatur Speicher Max. working temperature of cylinder					°C
Max. bedrijfstemperatuur accumulatie					
Wärmeverlust Heat loss					kWh/24h
Warmteverlies					
Stromaufnahme Electrical consumption					W
Opgenomen elektr. vermogen					
Stromvoorzorging Power supply					V-Hz
Elektrische voeding					
Erdschluss ist Vorschrift - Obligatory ground connection - Aarding verplicht					

RIELLO		RIELLO S.p.A. Via Ing.Pilade Rialto 7 37045 Legnago (VR) - ITALY		CE	
Seriennummer Serial number		Max. Betriebsdruck Speicher Max. working pressure of cylinder			bar
Model		Max. bedrijfstdruk accumulatie Max. working pressure of cylinder			
		Speichermass Storage capacity			l
		Accumulatiecapaciteit			

Serial number plate

This specifies the serial number and model.

! If these plates or any other means of clearly identifying the product are defaced, removed or lost, proper installation and servicing may be rendered difficult.

Mod. 200 ÷ 500

Data plate

It indicates the technical and performance data.

RIELLO		RIELLO S.p.A. Via Ing.Pilade Rialto 7 37045 Legnago (VR) - ITALY		CE	
PUFFERSPEICHER STORAGE CYLINDER VOORRAADVAT					
Model		Seriennummer Serial number		067610E	
Kode Code	Baujahr Year	Boowjaar			
Speichermass Storage cylinder capacity					l
Accumulatiecapaciteit					
Max. Betriebsdruck Speicher Max. working pressure of cylinder					bar
Max. bedrijfsdruk accumulatie					
Max. Betriebstemperatur Speicher Max. working temperature of cylinder					°C
Max. bedrijfstemperatuur accumulatie					
Wärmeverlust Heat loss					kWh/24h
Warmteverlies					
Stromaufnahme Electrical consumption					W
Opgenomen elektr. vermogen					
Stromvoorzorging Power supply					V-Hz
Elektrische voeding					
Erdschluss ist Vorschrift - Obligatory ground connection - Aarding verplicht					

RIELLO		RIELLO S.p.A. Via Ing.Pilade Rialto 7 37045 Legnago (VR) - ITALY		CE	
Seriennummer Serial number		Max. Betriebsdruck Speicher Max. working pressure of cylinder			bar
Model		Max. bedrijfstdruk accumulatie Max. working pressure of cylinder			
		Speichermass Storage capacity			l
		Accumulatiecapaciteit			

Serial number plate

This specifies the serial number and model.

! If these plates or any other means of clearly identifying the product are defaced, removed or lost, proper installation and servicing may be rendered difficult.

5 SYSTEM LAYOUT

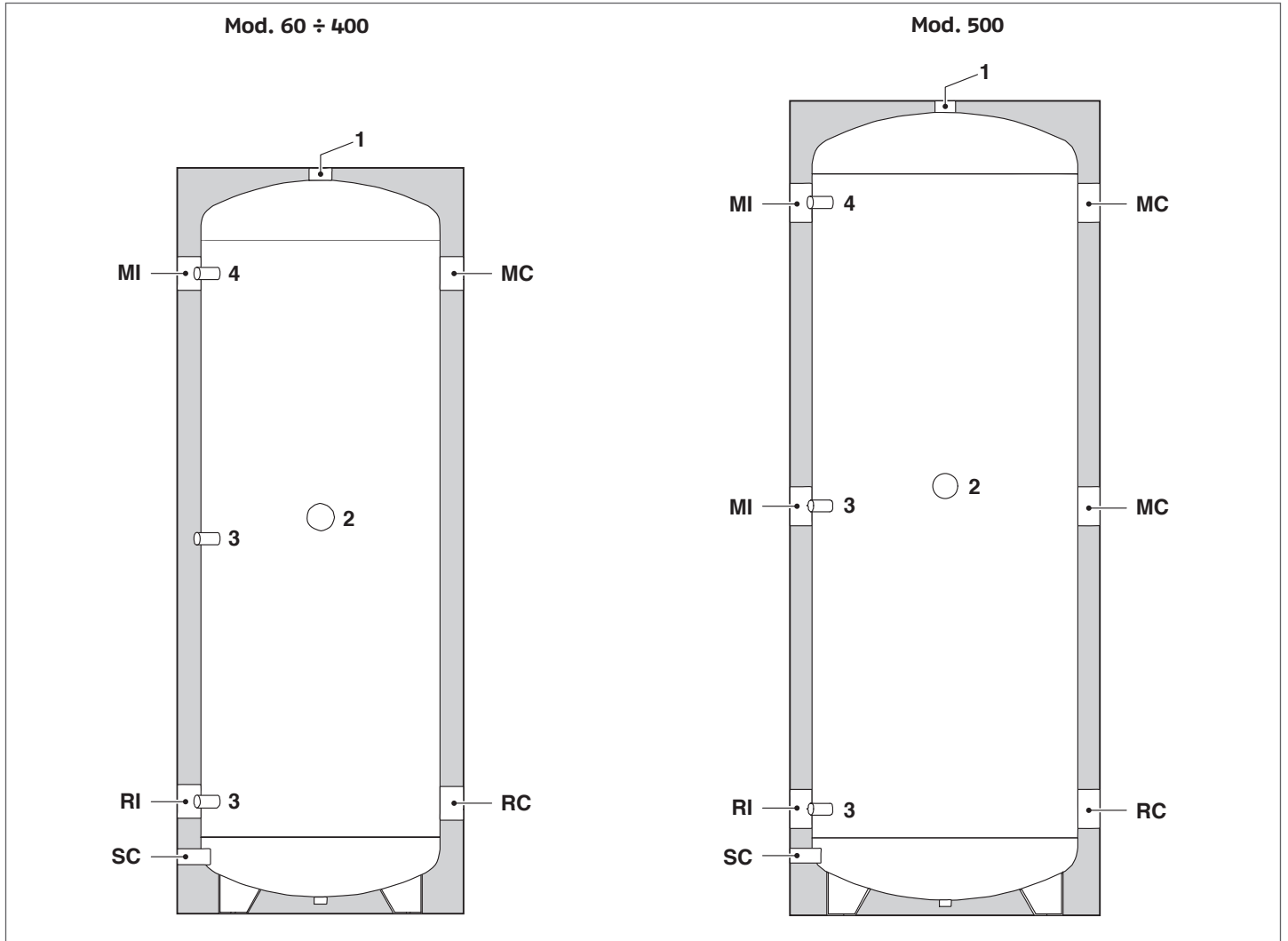

- 1 Vent
- 2 Fitting for electrical heating element
- 3 Temperature sensor sockets
- 4 Temperature gauge socket

- MI Central heating flow
- MC Outlet from boiler
- RI Central heating return
- RC Return to boiler
- SC Drain

MI Central heating flow

6 TECHNICAL SPECIFICATIONS

DESCRIPTION	7000 ACI PLUS						
	60	120	200	300	400	500	
Type of buffer tank	Non vitrified						
Tank layout	Vertical						
Diameter with insulation	400	500	550	600	700	700	mm
Height with insulation	935	1095	1395	1560	1540	1840	mm
Insulation thickness	50						mm
Maximum operating pressure	6						bar
Maximum operating temperature	99						°C
Net weight with insulation	25	35	45	55	95	100	kg
Useful volume	57	123	203	277	390	473	l
Dispersion	34	50	68	82	105	114	W
	0,816	1,2	1,632	1,968	2,52	2,74	kWh/24h
Insulation class	B	B	C	C	C	C	
Insulation type	Foamed hard PU						

7 WATER CIRCUIT

RIELLO 7000 ACI PLUS buffer tanks can be connected even to previously installed hot water sources, provided care is taken to ensure correct water flow directions.

TYPICAL WATER SYSTEM SCHEMATIC

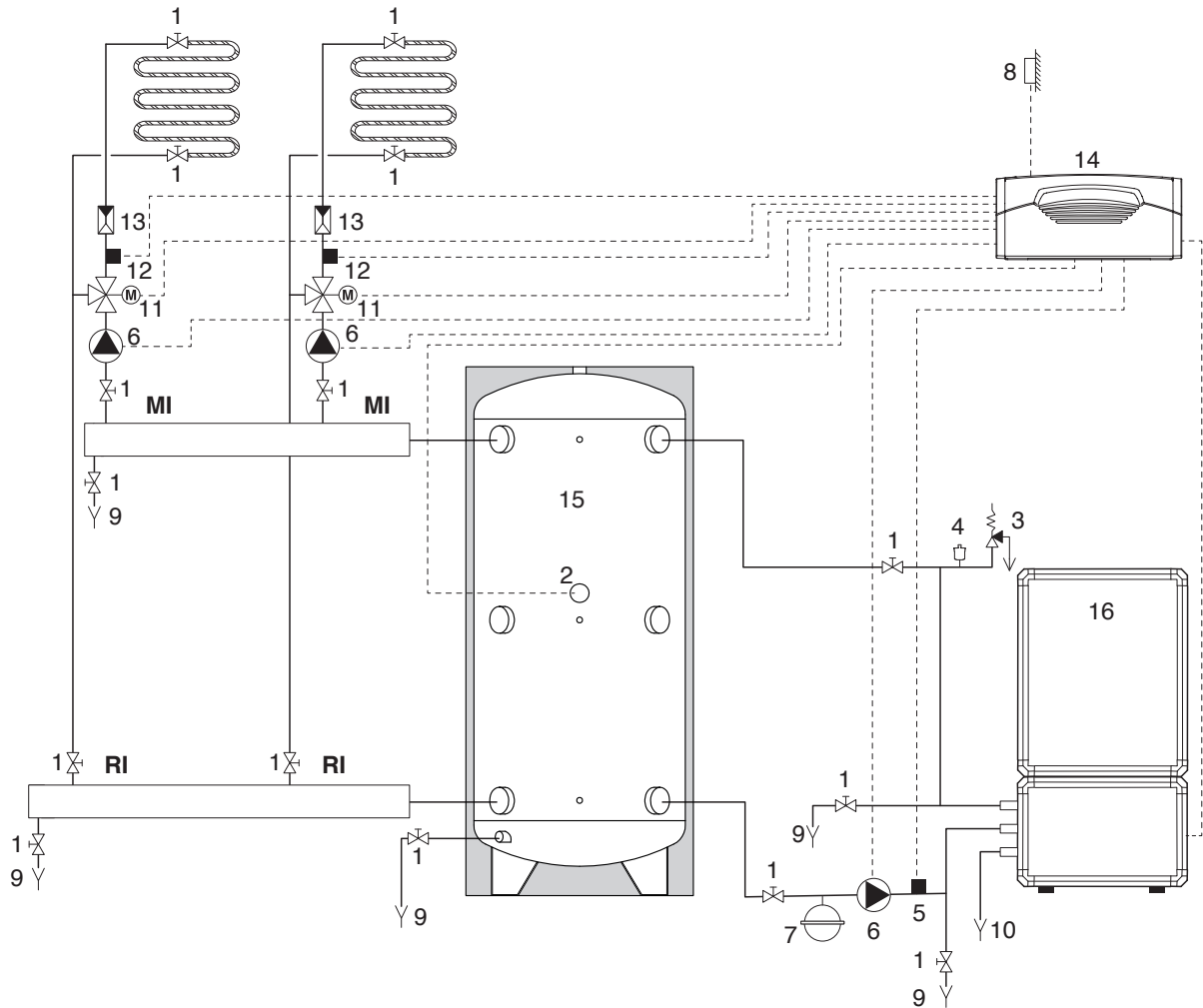

- 1 Isolating valve
- 2 Electrical heating element
- 3 Safety valve
- 4 Automatic bleed valve
- 5 Return probe
- 6 Central heating system pump
- 7 Expansion vessel
- 8 Outdoor sensor
- 9 Drain
- 10 Condensate outlet
- 11 Mixer valve
- 12 Flow temperature sensor
- 13 Non-return valve

- 14 Controller **RIELLO TECH**
- 15 Buffer tank **RIELLO 7000 ACI PLUS**
- 16 Heat pump **RIELLO HP AQ (*)**

- MI** Central heating flow
- RI** Central heating return
- (*)** Only in heating mode

Note! The above schematic is purely indicative.



⚠ Safety valves must be connected to a suitable collection and drain system. The manufacturer declines all responsibility for damage caused by water escaping from safety valves.

⚠ The selection and the installation of the components of the system is the responsibility of the installer, who must operate in accordance with good practice and current Legislation.

⚠ Circuits filled with anti-freeze must be fitted with water disconnectors.

8 LOCATION OF SENSORS

RIELLO 7000 ACI PLUS buffer tanks incorporate sockets for temperature control sensors.

-  The actual positioning of sensors depends on what components, water connections and control device are installed.
-  **The installer is responsible for making all necessary connections to the boiler and solar collectors. Installers must use their expertise to ensure proper installation and functioning in compliance with all applicable legislation.**
-  In case of a probe, any electric junction between probe cable and extensions for the connection to the electric panel must be soldered and protected with a sheath or a suitable electric insulation.

9 OVERALL DIMENSIONS AND WATER FITTINGS

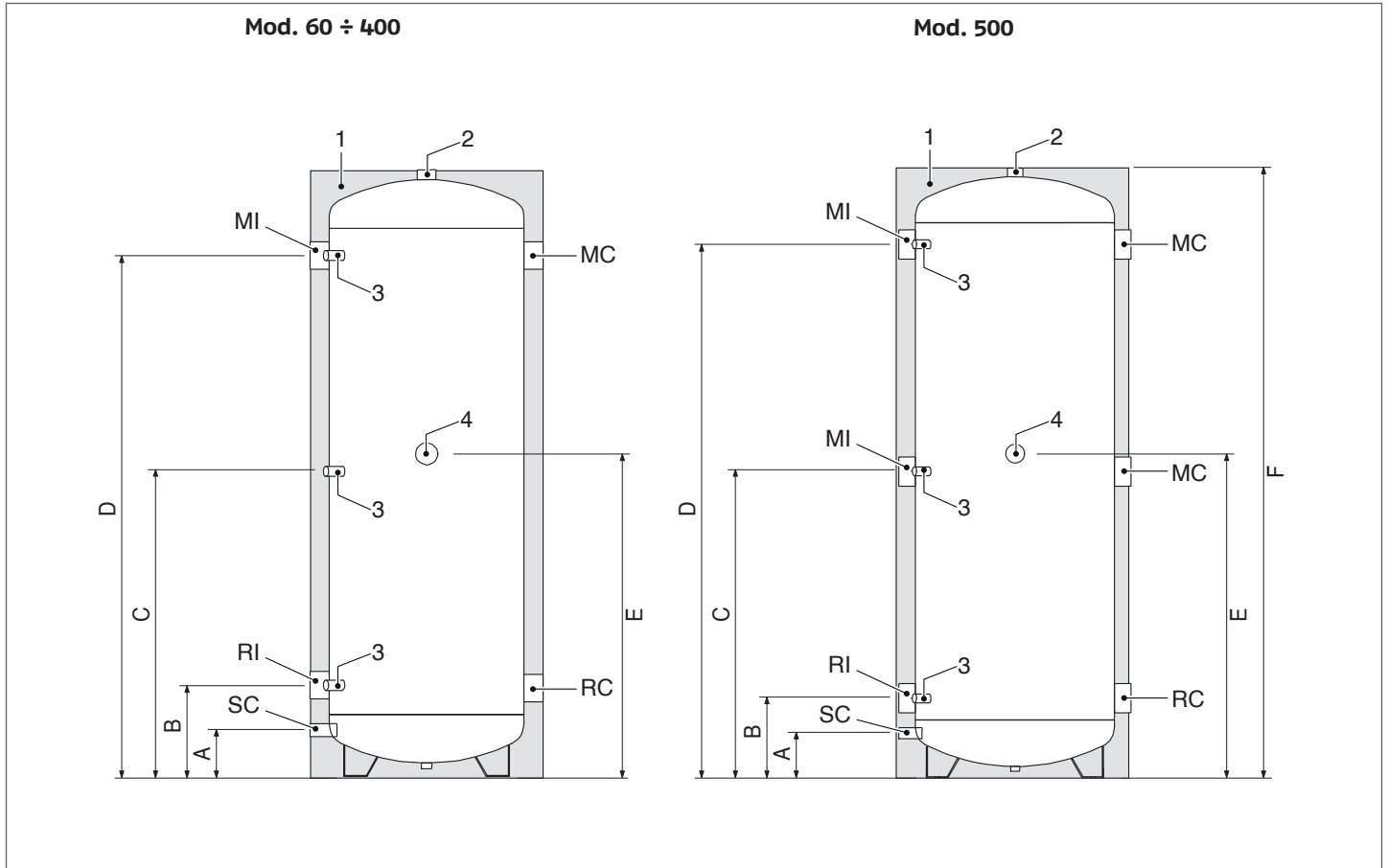

DESCRIPTION	7000 ACI PLUS						
	60	120	200	300	400	500	
1 Polyurethane insulation	50						mm
2 Vent valve fitting	1"		1 1/4"				∅
3 Sensor sockets	1/2" F						∅
4 Fitting for electrical heating element (not supplied)	1 1/2" F						∅
MI CH flow	1 1/4" F	1 1/4" F	1 1/2" F	2" F	2 1/2" F	2 1/2" F	∅
RI CH return	1 1/4" F	1 1/4" F	1 1/2" F	2" F	2 1/2" F	2 1/2" F	∅
SC Drain	1/2" F	1/2" F	1/2" F	3/4" F	3/4" F	3/4" F	∅
RC Return to boiler	1 1/4" F	1 1/4" F	1 1/2" F	2" F	2 1/2" F	2 1/2" F	∅
MC Outlet from boiler	1 1/4" F	1 1/4" F	1 1/2" F	2" F	2 1/2" F	2 1/2" F	∅
A	100	100	105	120	135	135	mm
B	180	185	215	235	240	240	mm
C	485	560	705	785	775	925	mm
D	785	935	1200	1340	1310	1610	mm
E	530	605	750	830	820	970	mm
F	935	1095	1395	1560	1540	1840	mm

⚠ We recommend that you install isolating valves in the outlet and return lines.

⚠ Check the efficiency of the seals when filling/refilling the buffer tank.

10 UNPACKING THE PRODUCT

RIELLO 7000 ACI PLUS buffer tanks are delivered in a single package, protected by a plastic bag and secured to a wooden pallet. The following items are delivered in a plastic bag inside the packaging:

- Instruction manual
- Warranty certificate and barcode label
- Spare parts catalogue
- Hydraulic test certificate
- 3 adjustable feet (Mod. 60 - 120)
- 2 wall mounting brackets (Mod. 60 - 120)

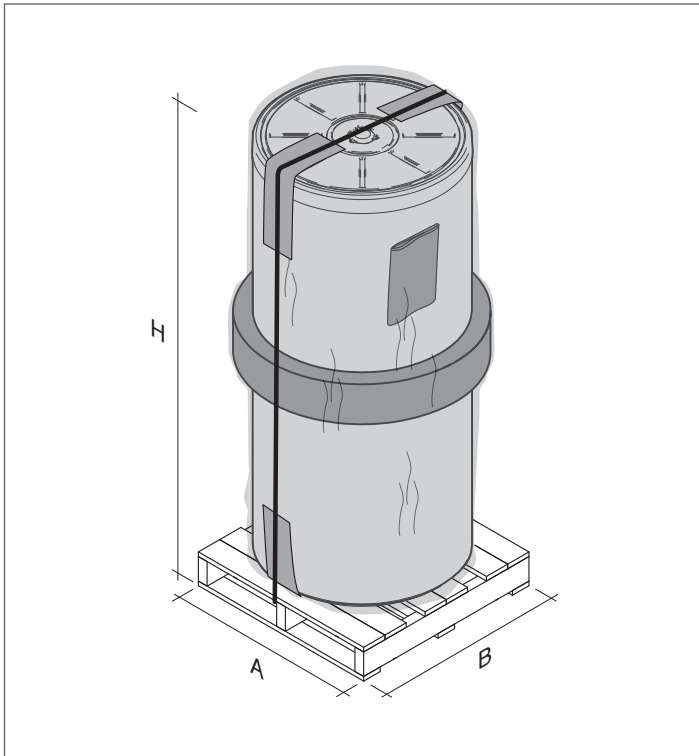

7000 ACI PLUS	A	B	H
60	600	600	1050
120	600	600	1210
200	600	600	1510
300	600	600	1670
400	700	700	1650
500	700	700	1950

11 HANDLING

Once you have removed the outer packaging, proceed as follows to unpack and handle the buffer tank.

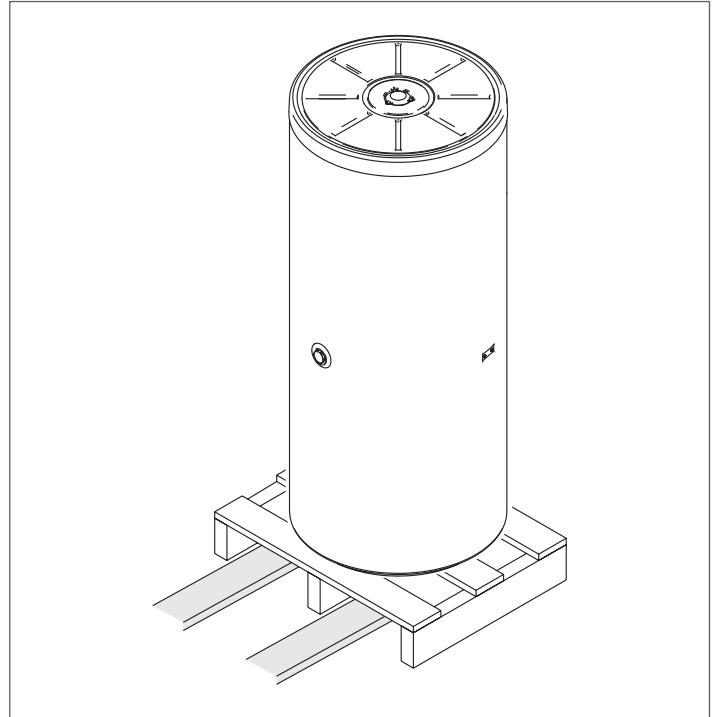

Only for models 7000 ACI PLUS 60-120

Adjust the feet to ensure that the storage cylinder is perfectly level.

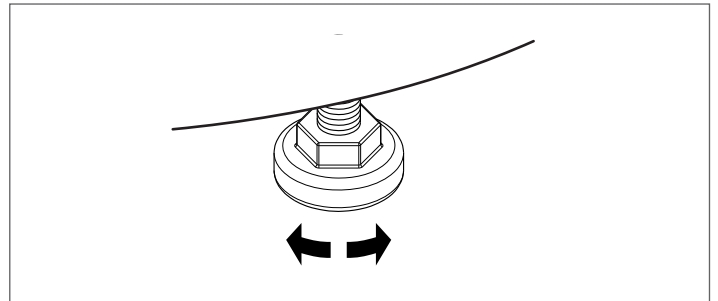

⚠ Wear suitable personal protective equipment and use suitable safety devices.

🚫 Do not dispose of packaging material into the environment, or leave it within the reach of children, since it can become a potential hazard. Dispose of packaging material in compliance with applicable legislation.

12 WALL MOUNTING

(Only for models 7000 ACI PLUS 60-120)

- Mark the fixing points on the wall using the brackets to check the distances between the holes
- Drill the wall
- Insert expansion plugs of a type and size suitable for the weight of the product when full and suitable for the type of wall
- Fix the 2 brackets to the buffer tank with the M8 bolts provided.
- Hang the appliance over the anchor points provided.

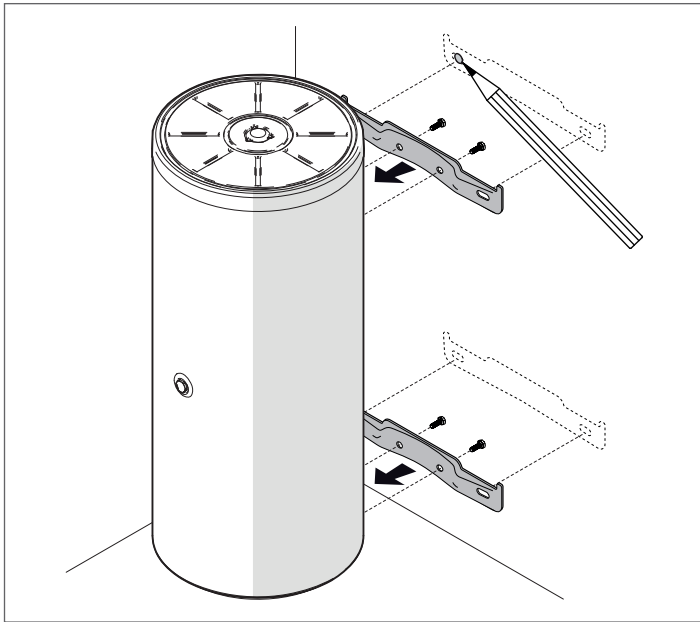

- ⚠ The operations of lifting and positioning on the wall must be performed by qualified personnel using equipment that is suitable for the weight involved and in conformity to all applicable safety standards in the country of installation.
- ⚠ Before commencing installation, identify the best position for the product on the basis of the minimum clearances needed around it.
- ⚠ The product must only be installed vertically.
- ⚠ Make sure that the selected section of wall is able to support the weight of the product when full and does not hide load bearing elements, water pipes or electrical cables.
- ⚠ Make sure that the expansion plugs used are able to support the weight of the product when full.

13 PLACE OF INSTALLATION

RIELLO 7000 ACI PLUS buffer tanks can be installed in any room where there is no specific requirement for an electrical protection rating higher than IP X0D.

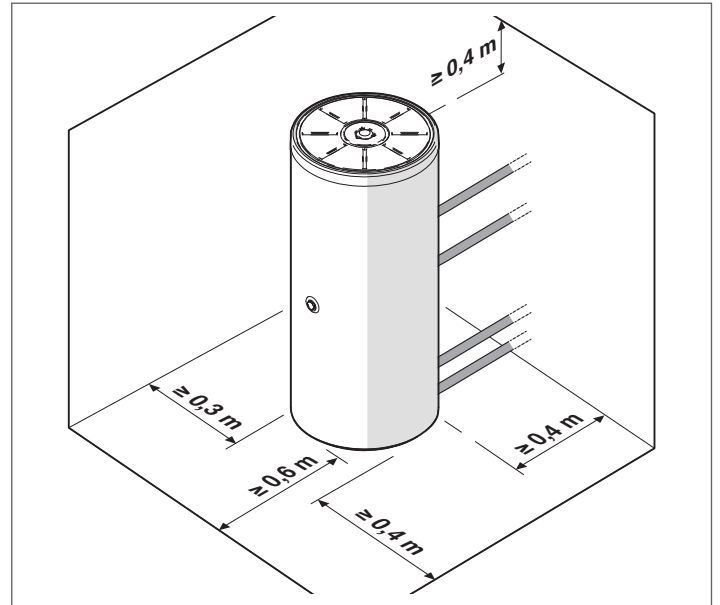

- ⚠ Respect the minimum specified installation distances to ensure correct installation and access for maintenance.

14 INSTALLATION IN OLDER SYSTEMS AND SYSTEMS REQUIRING MODERNISATION

When installing **RIELLO 7000 ACI PLUS** buffer tanks in old systems or systems requiring modernisation, always perform the following checks.

- Make sure that the system is fitted with safety and control devices in accordance with applicable legislation and standards
- Make sure that the central heating circuit has been flushed out to remove all sludge and lime scale, and has been vented and seal tested
- Make sure that a suitable water treatment system is installed if the quality of the supply/recirculation water so demands (refer to the reference values listed in the table alongside).

REFERENCE VALUES	
pH	6-8
Electrical conductivity	less than 200 μ S/cm (25°C)
Chlorine ions	less than 50 ppm
Sulphuric acid ions	less than 50 ppm
Total iron	less than 0.3 ppm
Alkalinity M	less than 50 ppm
Total hardness	less than 35°F
Sulphur ions	none
Ammonia ions	none
Silicon ions	less than 30 ppm

15 PUTTING INTO SERVICE

It is essential to perform the following checks before starting up or testing the functioning of the storage cylinder. In particular, check that:

- All the connections and pipes are watertight and the system has been filled and bled correctly
- Any water connections to a boiler or solar collectors have been made correctly
- Any solar heating circuit has been correctly flushed out and filled with water-glycol mix, and all air has been bled out of the circuit
- The electrical connections of all accessories have been made correctly
- Shut down the water heating system connected to the storage cylinder as instructed in its own manual.

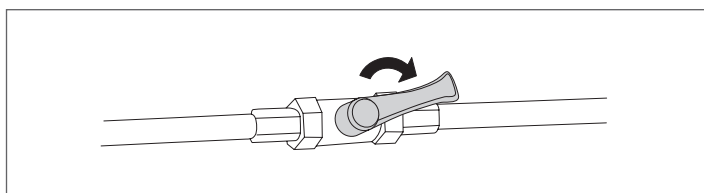

Once the system has been started up, perform the following checks:

- Make sure that all pumps are free and rotate in the right direction
- The complete venting of all circuits

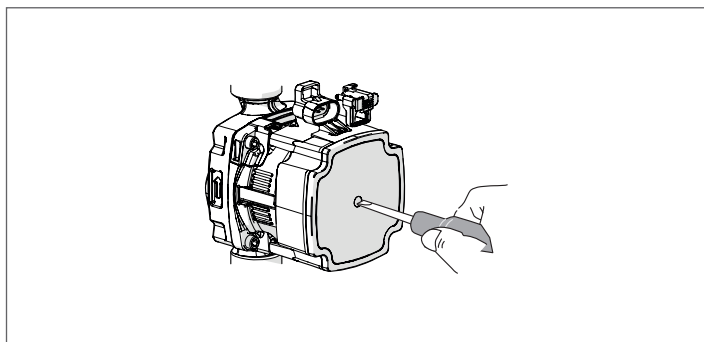

- Turn the main power switch OFF and make sure that the water heating system shuts down completely.

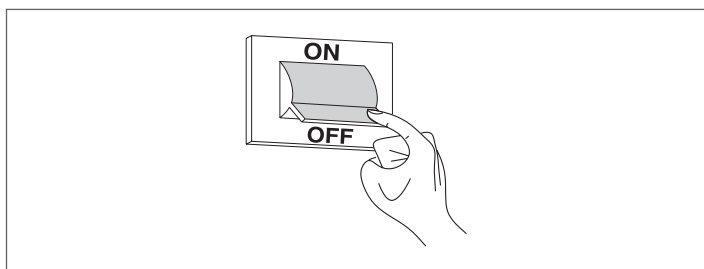

Provided the above checks have been completed satisfactorily, restart the system and verify its performance.

16 MAINTENANCE

Scheduled maintenance is essential for the safety, efficiency and long working life of your buffer tank. Proper maintenance also reduces energy consumption and ensures reliability over time. Have your buffer tank serviced either by the manufacturer's Technical Assistance Service or by a qualified heating engineer at least once a year.

Perform the following operations before beginning any maintenance:

- Switch the electricity supply to all the devices in the buffer tank's water circuit and to any associated boiler OFF at the main switch and at the control panel (if present)

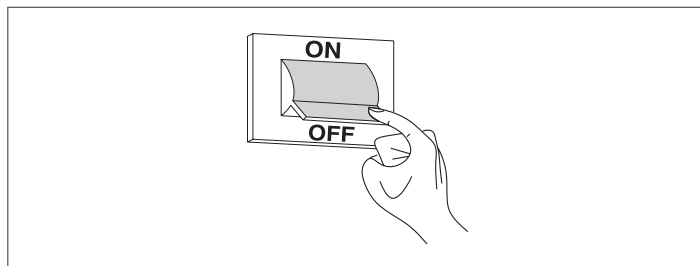

- Close the water shut-off cocks

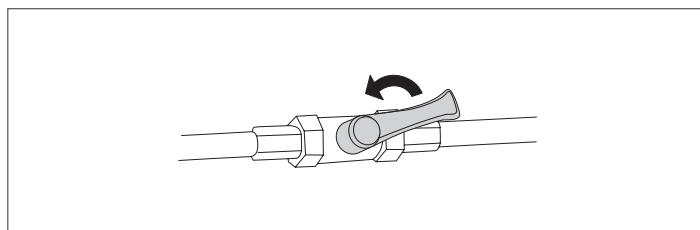

- Drain the buffer tank.

17 CLEAN THE BUFFER TANK

EXTERNAL CLEANING

Clean the outside of the buffer tank's insulation with a soft cloth dampened in soapy water. To remove stubborn marks, use a cloth dampened in a 50% mix of water and denatured alcohol or a suitable cleaning product. Dry the buffer tank after cleaning it.

- ⊖ Do not use abrasive products, petrol or triethylene.

18 RECYCLING AND DISPOSAL

At the end of its useful working life, do not abandon the buffer tank in the environment, but dispose of it through the proper channels in accordance with applicable legislation.

19 TROUBLESHOOTING

FAULT	CAUSE	SOLUTION
The buffer tank functions incorrectly or irregularly	Flow rate too high	- Fit a pressure limiter - Fit a flow reducer
	There are blockages or deposits in the buffer tank	- Check and clean as necessary
	Filling pump not functioning	- Check the pump
	The water temperature from the boiler is too low	- Check the setting
	There is air in the primary circuit	- Bleed the circuit
The safety valve is not functioning correctly	The safety valve is blocked or faulty	- Clean or change the valve
Water flows out of the safety valve	Valve faulty	- Replace the valve
	Circuit pressure too high	- Install a suitable pressure reducing device

END USER INSTRUCTIONS

Refer to the **GENERAL SAFETY INFORMATION** and **PRECAUTIONS** section for safety-related information.

20 START-UP

The buffer tank must be put into service for the first time by personnel from the manufacturer's Technical Assistance Service. Under certain circumstances, such as after long periods of disuse, the user may need to re-start it without involving the Technical Assistance Service. Before doing so, perform the following checks and operations:

- Check that the supply cocks in the domestic water circuit are all open
- Switch the electricity supply ON at the mains power switch and at control panel switch (if fitted).

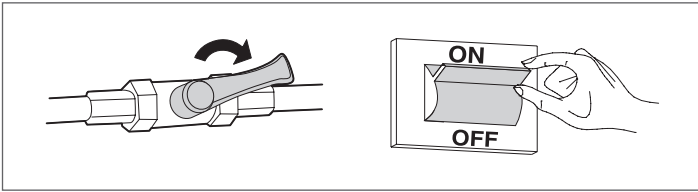

21 TEMPORARY SHUTDOWN

To reduce impact on the environment and save energy, before leaving for the weekend or a short break, etc., provided outdoor temperatures will remain above ZERO, simply adjust the buffer tank's temperature control device to its minimum setting.

! If outdoor temperature may drop below ZERO (risk of freezing) perform the operations described in the "Preparing for extended periods of disuse" section.

22 PREPARING FOR EXTENDED PERIODS OF DISUSE

If the buffer tank is not going to be used for an extended period of time, ask the manufacturer's Technical Assistance Service to make the system safe.

23 EXTERNAL MAINTENANCE

Clean the cover, painted and plastic parts with a cloth damped in soap and water. To remove stubborn marks, use a cloth damped in a 50% mix of water and denatured alcohol or a suitable cleaning product.

! Do not use fuels, sponges impregnated with abrasive solutions or powder detergents.

RIELLO

The manufacturer strives to continuously improve all products. Appearance, dimensions, technical specifications, standard equipment and accessories are therefore liable to modification without notice.