

ACUMULADOR INERCIAL DE 50 LITROS

50-LITER STORAGE TANK

Esta instrucción forma parte del manual del aparato en el que se instala el kit.

This instruction is an integral part of the instruction booklet of the appliance on which the kit is installed.

Remítirse a dicho manual para conocer las ADVERTENCIAS GENERALES y las REGLAS FUNDAMENTALES DE SEGURIDAD.

Please refer to this booklet for GENERAL WARNINGS and BASIC SAFETY RULES.

El kit está compuesto por:

	Cant.
1 Acumulador inercial 50 l	1
2 Pie regulable roscado M8	4
3 Brida de fijación en la pared	2
4 Tornillo M8	2
5 Válvula de descarga de la caldera	3
6 Niple 1" M - 1" M	2
7 Racor hidráulico F 1/2" - F 1/2"	3
8 Hoja de instrucciones	1

The kit is composed by:

	Q.ty
1 Storage tank	1
2 M8 threaded adjustable foot	2
3 Bracket for wall-mounted installation	2
4 M8 screw	2
5 Storage tank discharge valve	3
6 1" M - 1" M Nipple	2
7 F 1/2" - F 1/2" hydraulic connection	3
8 Instructions	1

⚠ Este kit debe ser instalado por personal profesionalmente cualificado.

⚠ This kit must only be installed by professionally qualified personnel.

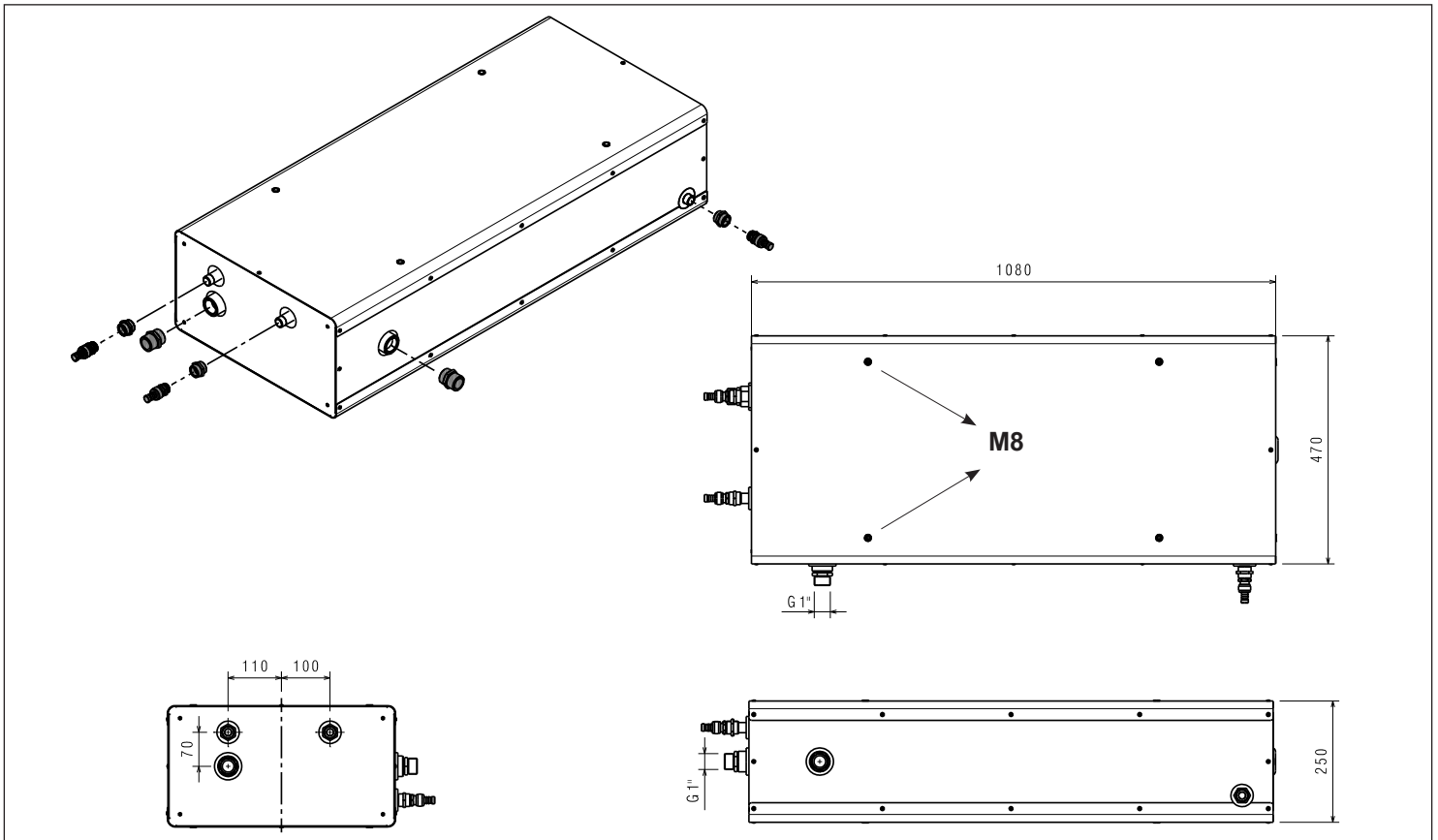
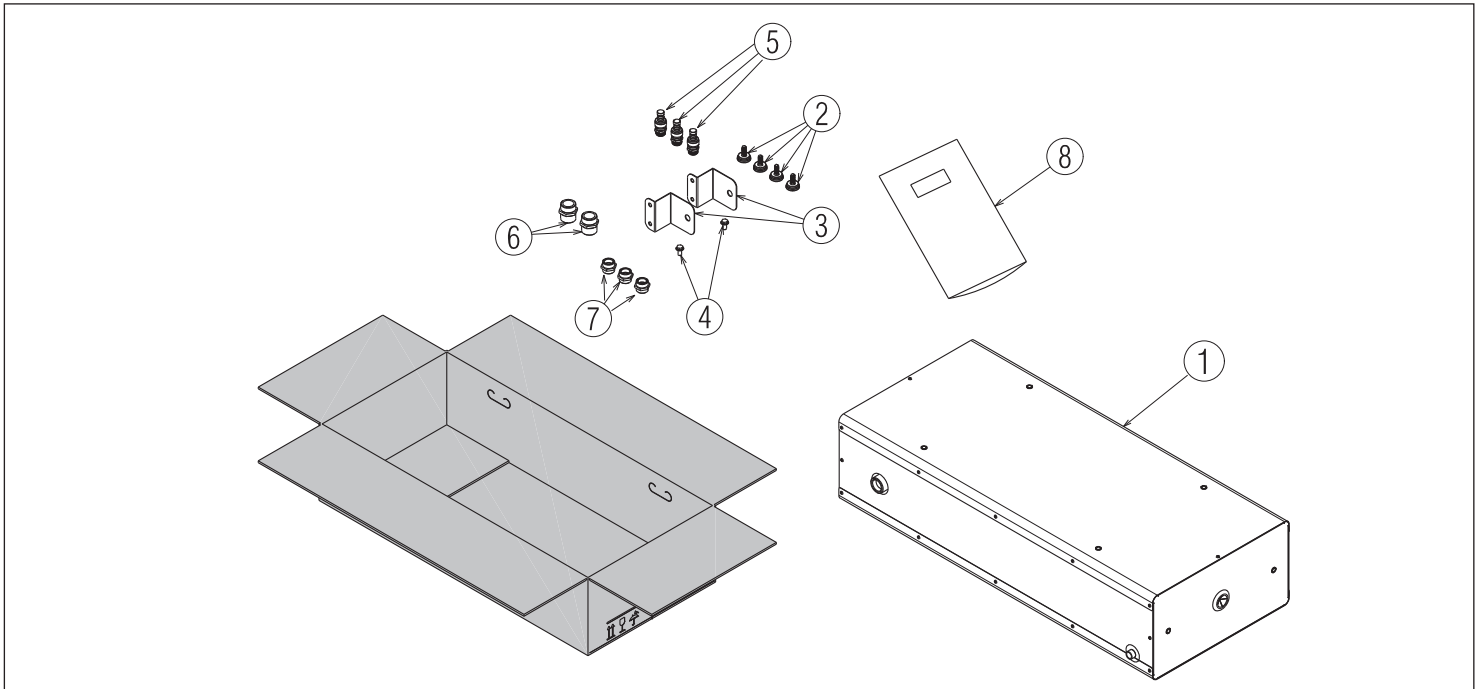

INSTALACIÓN MURAL/EN LA PARED/WALL INSTALLATION

1a)

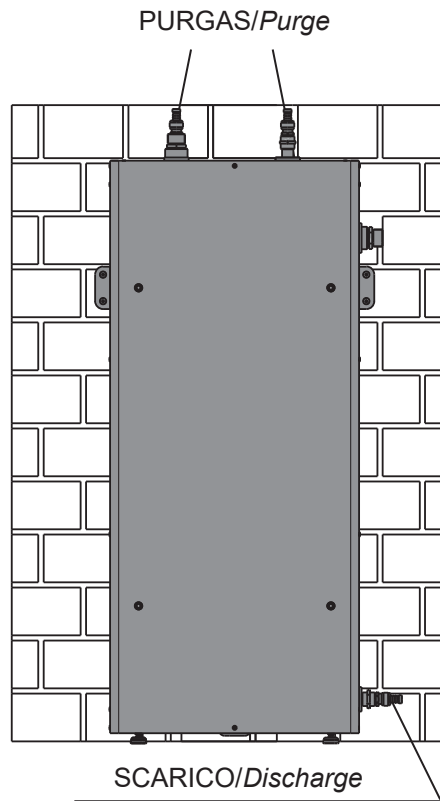
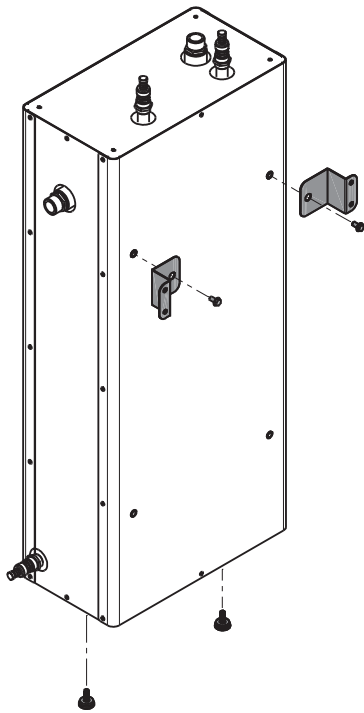

1b)

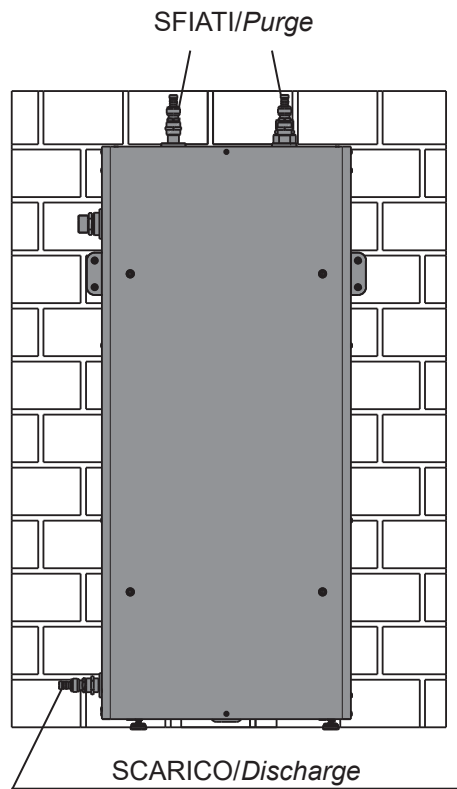
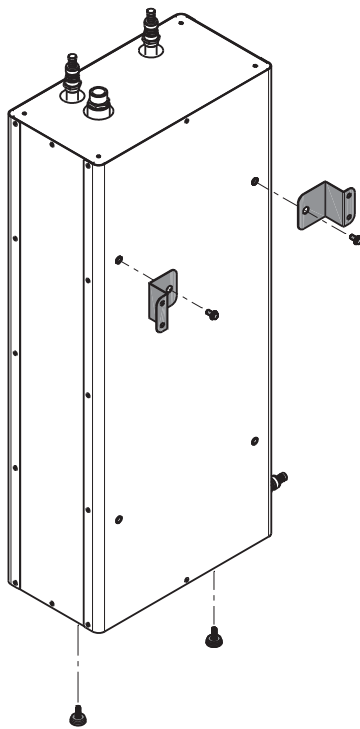

INSTALACIÓN EN EL SUELO/FLOOR INSTALLATION

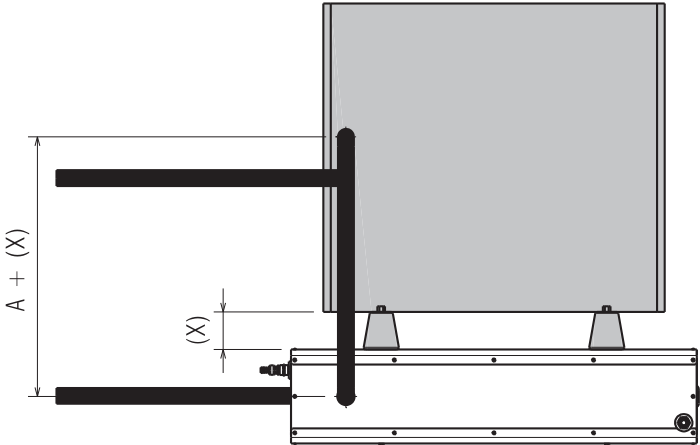
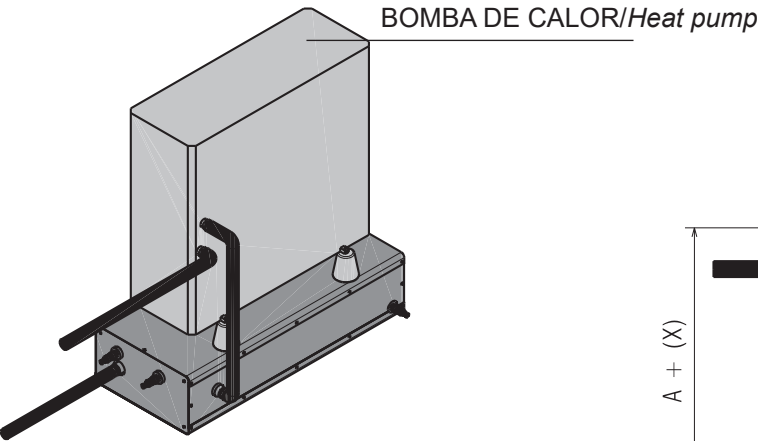
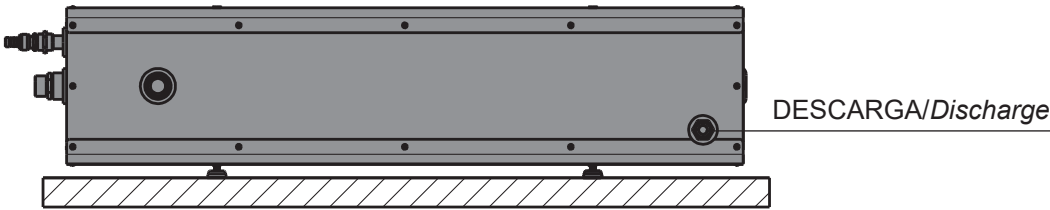
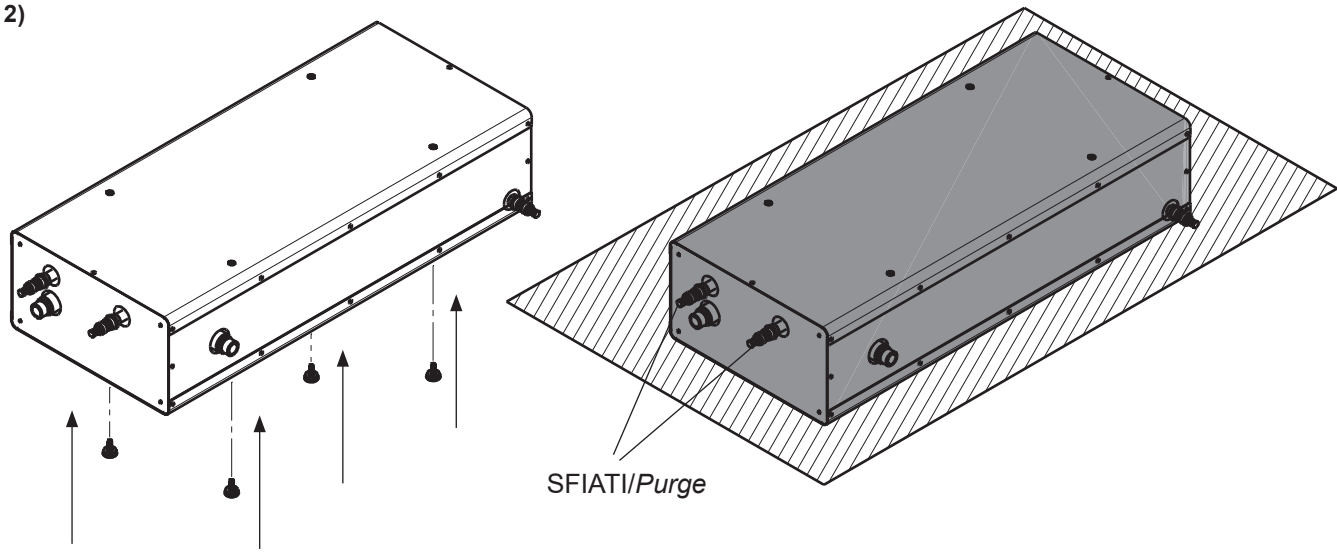

modelo/model	A
4-6-8 kW	591 mm
12 kW	875 mm

PÉRDIDAS DE CARGA
Pressure drops

