



Riello ADAPTO Hybrid

Hybrid systems – Wall-hung solutions

Multi-energy system designed to adapt to multiple system requirements while minimizing space requirements, flexible and easy to install

Suitable for heating, cooling and domestic hot water production

Proprietary intelligence stored in the system interface and also manageable via app

Choice between economic or ecological optimization mode

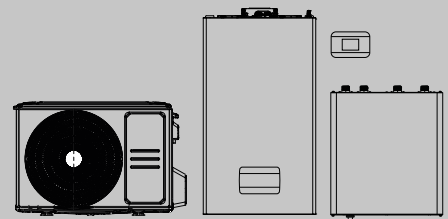

INDEX

Product description 3

System combinations 3

Technical data for outdoor unit 4

Technical data for indoor and outdoor units 4

Technical data for boiler START KIS 5

System energy data 7

Operating range 9

Overall dimensions and weights 10

Installation location 11

System layout 14

Hydraulic system. 18

Electrical connections 19

Control panel 21

Construction description for specifications 22

System example 25

PRODUCT DESCRIPTION

RIELLO ADAPTO HYBRID is the factory-made residential hybrid solution, ideal for replacing existing systems, which is part of the energy transition process in which Riello is actively involved. It is a compact and versatile multi-energy system, consisting of the RIELLO ADAPTO 3.5 or 5.0(*) kW heat pump in R32, the HYBRID hydraulic kit, the START condensing boiler in a combi version (KIS) of 25 or 30 kW, and the advanced system manager Hi, Comfort T300-HY. RIELLO ADAPTO HYBRID has been designed to adapt to a wide range of system requirements, offering simplicity and flexibility of installation, minimizing the space required both inside and outside the home. The compact hydraulic kit can be easily positioned either under or to the side of the boiler, up to a maximum distance of 15m. Outside, the extremely compact heat pump can be installed either on the floor or suspended on the wall with suitable support brackets, up to a maximum distance of 25m in length and 10m in height from the indoor unit. These features, together with Plug&Play technology, make the system quick and easy to install, ideal for both installers and end users. In a single solution, RIELLO ADAPTO HYBRID meets heating, cooling, and domestic hot water production needs, ensuring the best comfort throughout the year. It allows combined operation of the heat pump and boiler in heating mode. The combi boiler also provides instant domestic hot water production and, if the system is equipped with fan coils, the heat pump can provide hydronic cooling during the hottest periods.

The smart and intuitive digital user interface orchestrates the operation of the system and allows advanced control of the comfort of the home environment, optimizing consumption and adapting to the needs of users, both those who want to save on bills (economic optimization) and those who are more environmentally conscious (ecological optimization). The operation of RIELLO ADAPTO HYBRID can also be managed remotely, thanks to a specific section of the Hi, Comfort App.

SYSTEM COMBINATIONS

HYBRID SYSTEM	RIELLO ADAPTO HYBRID START 3.5 - 25	RIELLO ADAPTO HYBRID START 3.5 - 30	RIELLO ADAPTO HYBRID START 5.0 - 25	RIELLO ADAPTO HYBRID START 5.0 - 30
OUTDOOR UNIT	RIELLO ADAPTO 3.5	RIELLO ADAPTO 3.5	RIELLO ADAPTO 5.0*	RIELLO ADAPTO 5.0*
INDOOR UNIT	HYBRID HYDRAULIC KIT	HYBRID HYDRAULIC KIT	HYBRID HYDRAULIC KIT	HYBRID HYDRAULIC KIT
BOILER	START 25 KIS	START 30 KIS	START 25 KIS	START 30 KIS
CONTROL PANEL	Hi, Comfort T300-Hy	Hi, Comfort T300-Hy	Hi, Comfort T300-Hy	Hi, Comfort T300-Hy

(*) Not available at the time of printing.

HYBRID SYSTEMS

Hybrid systems – Wall-hung solutions

TECHNICAL DATA FOR OUTDOOR AND INDOOR UNIT

DESCRIPTION	notes	UoM	RIELLO ADAPTO	
Outdoor unit			HP OUTDOOR UNIT R32	
			3.5	5.0*
Indoor unit			HYBRID HYDRAULIC KIT	
ELECTRICAL FEATURES				
Electrical supply		V/PH/HZ	220-240V/1PH/50HZ	-
Nominal power consumption		A	3,67	-
Max. absorbed current		A	10	-
Min. power consumption		A	1,5	-
Max. power consumption		W	2300	-
Outdoor unit protection degree			IPX4	-
Indoor unit protection degree			IP21	-
HYDRAULIC AND GAS CONNECTIONS				
Refrigerant lines (to be connected to port A on the outdoor unit)				
Liquid connections		mm	6,35	-
Gas connections		mm	9,52	-
Maximum total length		m	25	-
Max length with pre-charged gas		m	5	-
Max. height difference between outdoor and indoor units		m	10	-
COMPRESSOR				
Compressor		Type	ROTARY	-
Oil		Type	VG74	-
Oil charge		W	0,44	-
Refrigerant		Type	R32	-
Refrigerant charge		kg	0,71	-
Max. permitted pressure		MPa	4.4	-
Discharge and suction pressure		MPa	4,3/1,7	-
Max. heating frequency		RPS	98	-
Min. heating frequency		RPS	26	-
Max. cooling frequency		RPS	55	-
Min. cooling frequency		RPS	25	-
FAN				
Fan		Type	Axial Flow Fan	-
Quantity		no.	1	-
Nominal air flow		m³/h	2200	-
Min. speed		RPM	230	-
Maximum speed		RPM	900	-
Max. power consumption		kW	0,034	-
NOISE LEVELS IN COOLING MODE – ODU				
Sound power		dB(A)	65	-
Sound pressure		dB(A)	57	-
NOISE LEVELS IN HEATING MODE – ODU				
Sound power		dB(A)	65	-
Sound pressure		dB(A)	57	-
SOUND LEVELS – IDU				
Sound power		dB(A)	47	-
TEMPERATURES				
Min./max. operating ambient temperature		°C	-15 / 50	-
Max. operating temperature of system water (heating)		°C	60	-
Min. operating temperature of system water (heating)		°C	24	-
Max. operating temperature of system water (cooling)		°C	22	-
Min. operating temperature of system water (cooling)		°C	5	-

(*) Not available at the time of printing.

HYBRID SYSTEM ENERGY DATA

DESCRIPTION	UoM	RIELLO ADAPTO	
Outdoor unit		RIELLO ADAPTO 3.5	RIELLO ADAPTO 5.0**
Indoor unit		HYBRID HYDRAULIC KIT	
Boiler		START 25/30 KIS	
ROOM HEATING			
TEMPERATE ZONE - LOW TEMPERATURE (30-35°C) EU REG. 811_2013			
Seasonal energy efficiency	%	151	-
SCOP		3,86	-
Prated	kW	3,5	-
Annual energy consumption	kWh/year	1884	-
Energy class	D → A+++ (*)	A++	-
TEMPERATE ZONE - MEDIUM TEMPERATURE (47-55°C) EU REG. 811_2013			
Seasonal energy efficiency	%	111	-
SCOP		2,85	-
Prated	kW	3,5	-
Annual energy consumption	kWh/year	2548	-
Energy class	D → A+++ (*)	A+	-
Outdoor unit sound power	dB(A)	65	-
Indoor unit sound power	dB(A)	47	-
ROOM COOLING TO 7°C - SEASONAL DATA			
Prated (declared cooling capacity) @35°C	kW	3,2	-
Seasonal EER (SEER)		4,81	-
Annual energy consumption (Qce)	kWh	399	-

NOTES:

The performances comply with the UNI EN 14511 and UNI EN 14825 standards.

(*) The range of energy efficiency class of this hybrid system category is between D and A+++.

(**) Not available at the time of printing.

HEAT PUMP ENERGY DATA

DESCRIPTION	UoM.	RIELLO ADAPTO	
Outdoor unit		RIELLO ADAPTO 3.5	RIELLO ADAPTO 5.0 (**)
Indoor unit		HYBRID HYDRAULIC KIT	
Electrical resistance		-	
ROOM HEATING			
TEMPERATE ZONE - LOW TEMPERATURE (30-35°C) EU REG. 811_2013			
Seasonal energy efficiency	%	150	-
SCOP		3,83	-
Prated	kW	3,50	-
Energy class	D → A+++ (*)	A++ (*)	-
Outdoor unit sound power	dB(A)	62	-
Indoor unit sound power	dB(A)	45	-
TEMPERATE ZONE - MEDIUM TEMPERATURE (47-55°C) EU REG. 811_2013			
Seasonal energy efficiency	%	110	-
SCOP		2,83	-
Prated	kW	3,50	-
Energy class	D → A+++ (*)	A+ (*)	-
Outdoor unit sound power	dB(A)	65	-
Indoor unit sound power	dB(A)	47	-
ROOM COOLING TO 7°C - SEASONAL DATA			
Prated (declared cooling capacity) @35°C	kW	3,2	-
Seasonal EER (SEER)		4,81	-
Annual energy consumption (Qce)	kWh	399	-

NOTES

The performances comply with the UNI EN 14511 and UNI EN 14825 standards.

(*) The range of energy efficiency class of this product category is between D and A+++

HYBRID SYSTEMS

Hybrid systems – Wall-hung solutions

UNI 11300 PARTS 3 AND 4: PERFORMANCE ACCORDING TO UNI EN 14511 AND UNI EN 14825

OUTDOOR UNIT (ODU):

RIELLO ADAPTO 3.5*

INDOOR UNIT (IDU):

HYBRID HYDRAULIC KIT

HEATING				
Dry bulb temperature air inlet (°C)	Water flow rate (m³/h)	Water temperature outlet (°C)	Capacity (kW)	COP
-15	0,6	35	2,00	1,70
-7	0,6	35	2,90	2,34
2	0,6	35	2,89	3,10
7	0,6	35	3,50	4,00
12	0,6	35	3,55	4,40
-15	0,6	42	2,10	1,40
-7	0,6	45	2,89	2,00
2	0,6	45	2,75	2,70
7	0,6	45	3,50	3,40
12	0,6	45	3,55	3,80
-7	0,39	55	2,80	1,60
2	0,39	55	2,70	1,90
7	0,39	55	3,50	2,50
12	0,39	55	3,50	3,00
COOLING				
Dry bulb temperature air inlet (°C)	Water flow rate (m³/h)	Water temperature outlet (°C)	Capacity (kW)	EER
35	0,55	7	3,20	2,90
35	0,55	18	3,30	4,40
27	0,55	7	3,30	3,80
27	0,55	18	3,40	4,90
46	0,55	7	1,95	1,70

HEATING – Partial load data					
Tbival (-7°C)	A	B	C	D	
Outdoor temperature (°C)	-7	2	7	12	
PLR – Climate load factor	0,88	0,54	0,35	0,15	
DC – Full load power	2,90	2,89	3,50	3,55	
COP at full load	2,34	3,10	4,00	4,40	
COP at partial load	2,33	3,28	3,47	3,68	
CR – Load factor	1,00	0,65	0,35	0,15	
f COP – Adjustment factor	1,00	1,06	0,87	0,84	

COOLING – Partial load data			
Condition (A) 35°C	Pdc (declared cooling capacity)	3,24	kW
	EERd (declared EER)	3,08	-
	Cdc (degradation coefficient)	0,983	-
Condition (B) 30°C	Pdc (declared cooling capacity)	2,46	kW
	EERd (declared EER)	4,25	-
	Cdc (degradation coefficient)	0,969	-
Condition (C) 25°C	Pdc (declared cooling capacity)	1,61	kW
	EERd (declared EER)	6,21	-
	Cdc (degradation coefficient)	0,932	-
Condition (D) 20°C	Pdc (declared cooling capacity)	1,53	kW
	EERd (declared EER)	5,49	-
	Cdc (degradation coefficient)	0,936	-

(*) The 5.0 kW size not available at time of printing

HEATING

The performances comply with the UNI EN 14511 and UNI EN 14825 standards. Partial load performance refers to a water flow temperature of 35°C.

COOLING

Performance according to UNI EN 14825 standards

OPERATING RANGE

INDOOR UNIT:

HEATING CYCLE		Min.	Max.
Room air (DB: Dry Bulb)	°C	5	30
Outdoor air (DB: Dry Bulb)	°C	-15	24
COOLING CYCLE			
Room air (DB: Dry Bulb)	°C	16	32
Outdoor air (DB: Dry Bulb)	°C	10	50

The limits are based on the following conditions:

Pipe length: 5m

Height difference: 0m

Air flow: max.

OUTDOOR UNIT:

COOLING MODE

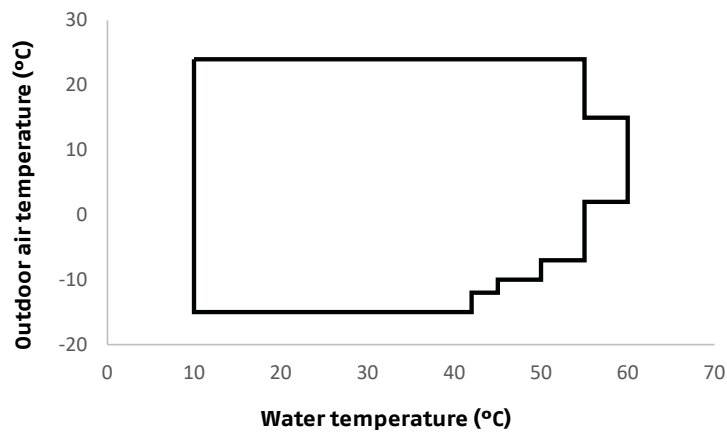

HEATING MODE

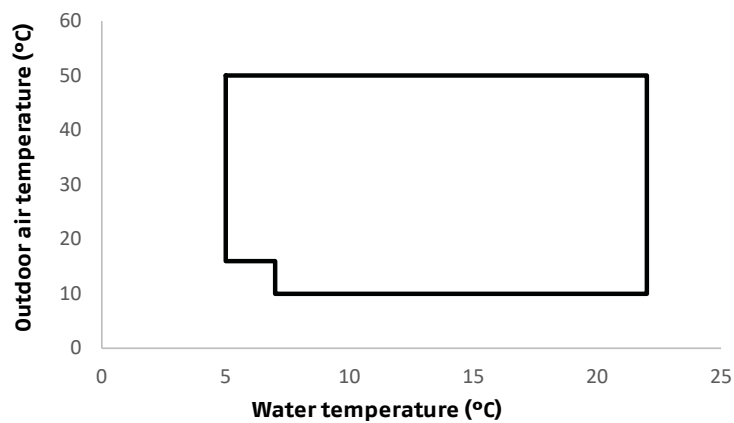

HYBRID SYSTEMS

Hybrid systems – Wall-hung solutions

TECHNICAL DATA FOR BOILER START KIS

DESCRIPTION	NOTES	UoM.	START 25 KIS			START 30 KIS		
			G20	G230	G31	G20	G230	G31
Type of gas			G20	G230	G31	G20	G230	G31
Appliance category								
Type of appliance			B23P-B53P-C13-C13X-C33-C33X-C43-C43X-C53-C53X-C83-C83X-C93-C93X					
HEATING								
Nominal heat flow (Hi)		KW	20,00			25,00		
Nominal heat output (80-60°C)		KW	19,38			24,38		
Nominal heat output (50-30°C)		KW	20,92			26,78		
Reduced heat flow (Hi)		KW	3,10	3,10	5,00	3,95	3,95	5,00
Reduced heat output (80-60°C)		KW	2,94	2,94	4,74	3,79	3,79	4,81
Reduced heat output (50-30°C)		KW	3,04	3,04	4,91	4,09	4,09	5,19
DOMESTIC WATER								
Nominal heat flow (Hi)		KW	25,00			30,00		
Nominal heat output	(1)	KW	25,00			30,00		
Reduced heat flow (Hi)		kW	3,10	3,10	5,00	3,95	3,95	5,00
Reduced heat output	(1)	kW	3,10	3,10	5,00	3,95	3,95	5,00
EFFICIENCY								
Useful efficiency Pn max-Pn min (80-60°C)		%	96,9 - 94,7			97,5 - 96,0		
Useful efficiency Pn max-Pn min (50-30°C)		%	104,6 - 98,0			107,1 - 103,6		
Useful efficiency 30% (return 30°C)		%	109,1			108,8		
Average D performance Range Rated (80-60°C)		%	97,0			97,3		
Average D performance Range Rated 30% (30°C return)		%	109,3			109,0		
Combustion efficiency		%	97,2			97,7		
Chimney losses with burner on (Pn max)		%	2,8			2,3		
Chimney losses with burner off		%	0,09			0,08		
Shell losses with burner on (Pn max)		%	0,3			0,2		
FLUE GAS SYSTEMS								
NOx class – UNI EN 15502			6			6		
Residual head concentric flue gas 0,85 m Ø60-100 mm		Pa	60			60		
Residual head separate flue gas 0,5 m Ø80 mm		Pa	180			190		
Residual boiler head without pipes and without flange		Pa	186			196		
ELECTRICAL CHARACTERISTICS								
Electrical power (Pel max heating- Pel max DHW)		W	62 - 95			85 - 102		
Electric power of circulator (1000 W)		W	42			42		
Power supply		V - Hz	230-50			230-50		
Electrical protection level		IP	X5D			X5D		
HEATING OPERATION								
Max. pressure		bar	3			3		
Min. pressure for standard operation		bar	0,25			0,25		
Max. temperature:		°C	90			90		
H ₂ O heating temperature selection range		°C	20/45 - 40/80			20/45 - 40/80		
Pump: max. head available to the system		mbar	408			408		
at flow rate of		l/h	1000			1000		
Diaphragm expansion vessel		W	8			8		
Preload expansion vessel		bar	1			1		
DHW OPERATION – INSTANT VERSION								
Max. pressure		bar	8			8		
Min. pressure		bar	0,5			0,5		
Hot water quantity with Δt 25°C		l/min	14,3			17,2		
with Δt 30°C		l/min	11,9			14,3		
with Δt 35°C		l/min	10,2			12,3		
Min. domestic water flow		l/min	2			2		
H ₂ O DHW temperature selection range.		°C	37/60			37/60		
Flow regulator		l/min	10			12		
AIR AND FLUES FLOW								
Type of gas			G20	G230	G31	G20	G230	G31
Heating air flow		Nm ³ /h	24,3	24,1	24,8	30,4	30,1	31,0
DHW air flow		Nm ³ /h	30,4	30,1	31,0	36,4	36,2	37,2

DESCRIPTION	NOTES	UoM.	START 25 KIS			START 30 KIS		
Heating flue gas flow		Nm ³ /h	26,3	26,4	26,4	32,9	33,1	32,9
DHW flue gas flow		Nm ³ /h	32,9	33,1	33,0	39,4	39,7	39,5
Max. heating flue gas mass flow		g/s	9,1	9,3	9,3	11,3	11,6	11,6
Max. DHW flue gas mass flow		g/s	11,4	11,7	11,6	13,6	14,0	13,9
Min. flue gas mass flow		g/s	1,4	1,4	2,3	1,8	1,8	2,3
Min. DHW flue gas mass flow		g/s	1,4	1,4	2,3	1,8	1,8	2,3
EMISSION VALUES AT MAX. AND MIN. FLOW RATES WITH GAS ⁽²⁾								
Type of gas			G20	G230	G31	G20	G230	G31
Max.								
CO s.a. less than		p.p.m	140	80	140	150	130	150
CO ₂		%	9,0	10,0	10,0	9,0	10,0	10,0
NOx s.a. less than		p.p.m	50	50	40	50	50	40
Flues temperature		°C	77	78	81	70	71	72
Min.								
CO s.a. less than		p.p.m	10	10	30	10	10	20
CO ₂		%	9,0	10,0	10,0	9,0	10,0	10,0
NOx s.a. less than		p.p.m	30	50	40	40	50	50
Flues temperature		°C	64	61	63	63	59	60

(1) Average value between the various operating conditions in DHW mode.

(2) Test performed with concentric flue Ø60-100 mm - length 0,85 m - water temperature 80-60°C.

ERP TECHNICAL DATA FOR START KIS

DESCRIPTION	Symbol	UoM	START 25 KIS	START 30 KIS
Seasonal space heating energy efficiency class	-	D → A+++ ⁽¹⁾	A	A
Water heating energy efficiency class	-	F → A+ ⁽²⁾	A	A
Rated heat output	Pnominale	kW	19	24
Seasonal space heating energy efficiency	ηs	%	93	93
USEFUL HEAT OUTPUT				
At rated heat output, high-temperature regime (*)	P4	kW	19,4	24,4
At 30% of rated heat output and low-temperature regime (**)	P1	kW	6,5	8,2
USEFUL EFFICIENCY				
At rated heat output and high-temperature regime (*)	η4	%	87,3	87,6
At 30% of rated heat output and low-temperature regime (**)	η1	%	98,5	98,2
AUXILIARY ELECTRICITY CONSUMPTION				
At full load	elmax	W	32,0	38,0
At part load	elmin	W	12,0	12,0
In Stand-by mode	PSB	W	3,0	3,0
OTHER PARAMETERS				
Standby heat losses	Pstby	W	30,0	32,0
Pilot flame energy consumption	Pign	W	-	-
Annual energy consumption	QHE	GJ	42	56
Sound power level, indoors	LWA	dB	50	53
NOx emissions	NOx	mg/kWh	22	22
ACQUA CALDA SANITARIA				
Declared load profile			XL	XL
DHW energy efficiency	ηwh	%	84	84
Daily electricity consumption	Qelec	kWh	0,133	0,152
Daily fuel consumption	Qfuel	kWh	23,183	23,306
Annual electricity consumption	AEC	kWh	29	33
Annual fuel consumption	AFC	GJ	18	18

(*) High-temperature regime means: 60°C Return and 80°C Flow of the boiler.

(**) Low temperature regime means for condensing boilers 30°C, for low-temperature boilers 37°C and for other heaters 50°C return temperature.

(1) The range of energy efficiency class of this products category is between D and A+++.

(2) the range of energy efficiency class of this products category is between F and A+

NOTE

With reference to Delegated Regulation (EU) No 811/2013, the data shown in the table can be used to complete the product fiche and labelling for space heaters, combination heaters, packages of space heaters, temperature controls and solar devices:

	CLASS	BONUS
OUTDOOR PROBE	II	2%
OT+ REMOTE CONTROL	V	3%
OUTDOOR PROBE + OT+ REMOTE CONTROL	VI	4%

HYBRID SYSTEMS

Hybrid systems – Wall-hung solutions

OVERALL DIMENSIONS AND WEIGHTS

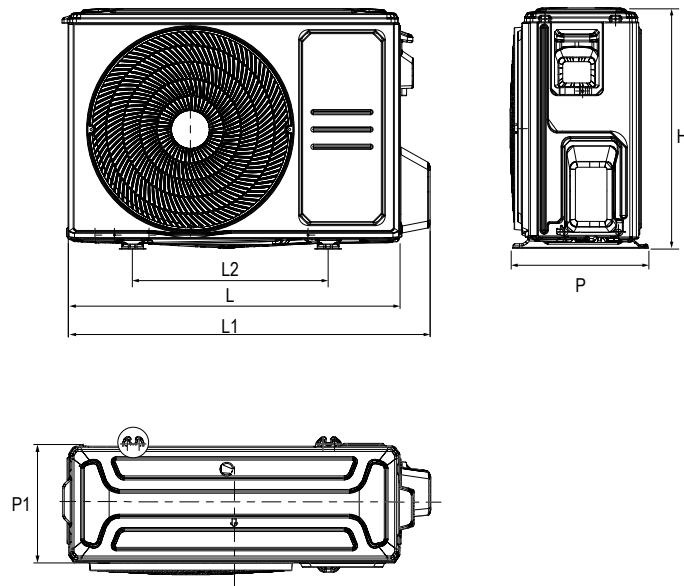

OUTDOOR UNIT

MODELS		UoM.	RIELLO ADAPTO	
OUTDOOR UNIT			3.5	5.0*
Height	H	mm	557	-
Width	W	mm	771	-
Width	W1	mm	839	-
Width	W2	mm	452	-
Depth	D	mm	304	-
Depth	D1	mm	274	-
Weight		kg	28,1	-

(*) Not available at the time of printing.

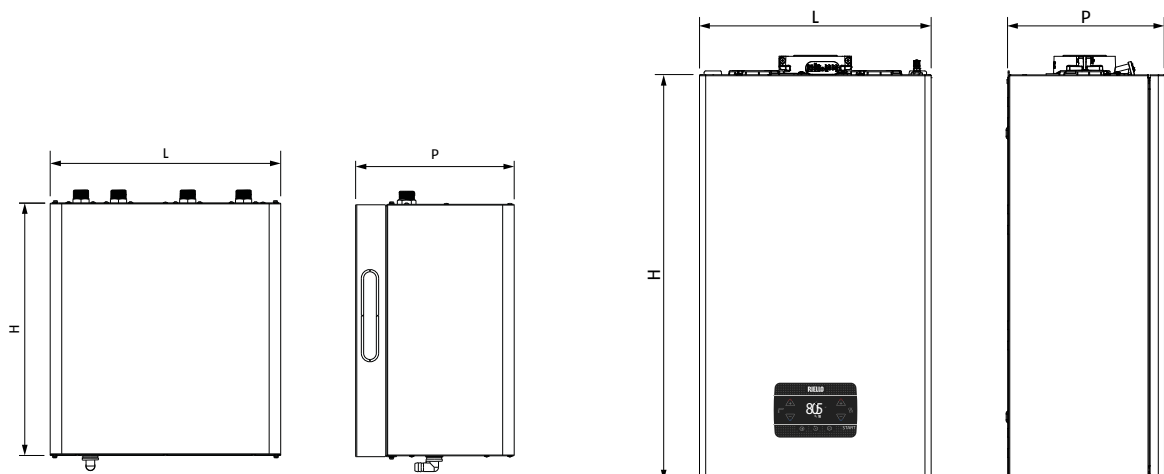

INDOOR UNIT AND BOILER

MODELS		UoM.	Hybrid hydraulic kit	START	
OUTDOOR UNIT				25 KIS	30 KIS
Height	H	mm	436	700	700
Width	W	mm	400	400	400
Depth	D	mm	275	275	275
Net weight		kg	19,5	28,5	30,0

INSTALLATION LOCATION

PRELIMINARY WARNINGS FOR R32

The appliance must be installed in well-ventilated areas with a minimum floor space as shown below in the 'OUTDOOR UNIT' section, depending on the total refrigerant charge of the circuit. The refrigerant charge refers to the total charge of the circuit, which is the sum of the factory charge and any additional charge. For the quantity of refrigerant gas charged in the unit, refer to the technical plate on the matching outdoor unit. If the appliance is located in a poorly ventilated area, precautions must be taken to prevent stagnation in the event of a refrigerant leak, so as not to create a risk of fire or explosion. The appliance must be placed in a room where there are no continuously operating open flames (e.g., a gas appliance in operation) or sources of ignition (e.g., an electric heater in operation). Any ventilation openings must be kept free from obstacles.

Perform the following checks:

- carry out safety checks to ensure that the risk of combustion is minimized
- avoid working in confined spaces
- delimit the area around the workspace
- ensure safe working conditions around the area by controlling flammable material.

INDOOR UNIT

The clearance areas for installation and maintenance of the appliance are shown in the figure. The specified spaces are necessary to avoid obstructions to air flow and to allow normal cleaning and maintenance operations.

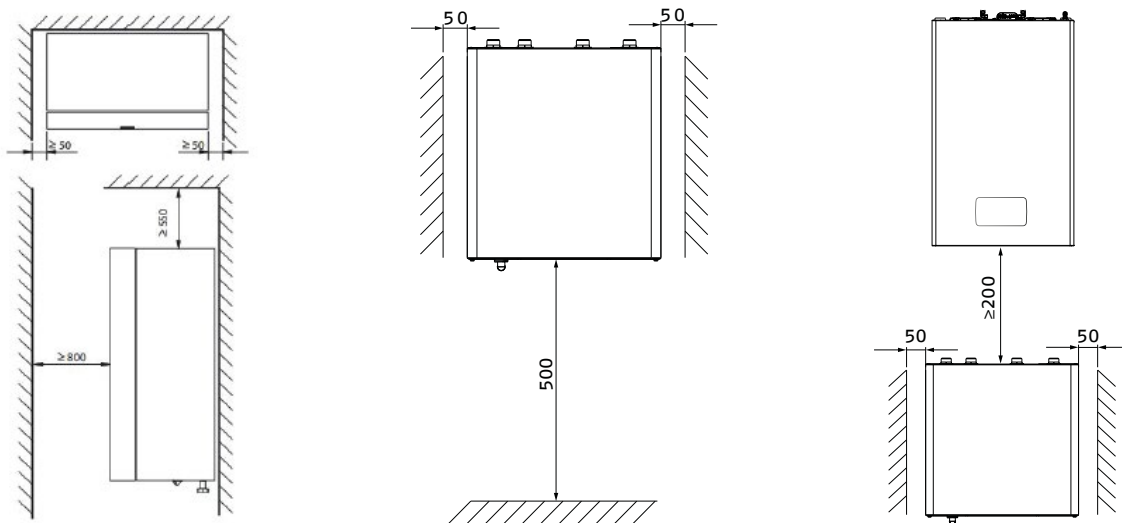

HYBRID SYSTEMS

Hybrid systems – Wall-hung solutions

Position the appliance, keeping in mind that:

- it must be installed on a wall capable of supporting its weight;
- it must not be positioned above a stove or other cooking appliance;
- it is forbidden to leave flammable substances in the room where the kit is installed.
- the hydraulic kit must be installed below the boiler or to the side of it, at a distance equivalent to a linear pipe with a 3/4" section not exceeding 15 meters on the flow side and 15 meters on the return side.
- the hydraulic kit cannot be positioned above the vertical level of the boiler

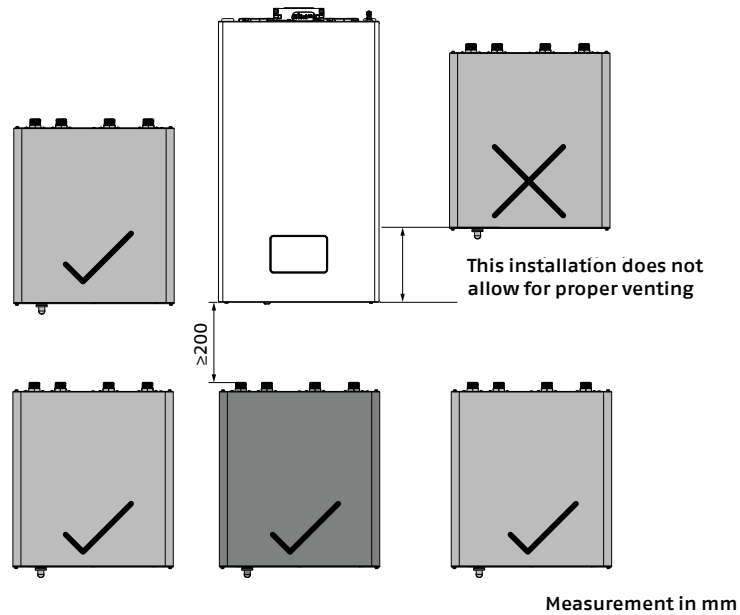

OUTDOOR UNIT

The clearance areas for installation and maintenance of the appliance are shown in the figure. The specified spaces are necessary to avoid obstructions to air flow and to allow normal cleaning and maintenance operations.

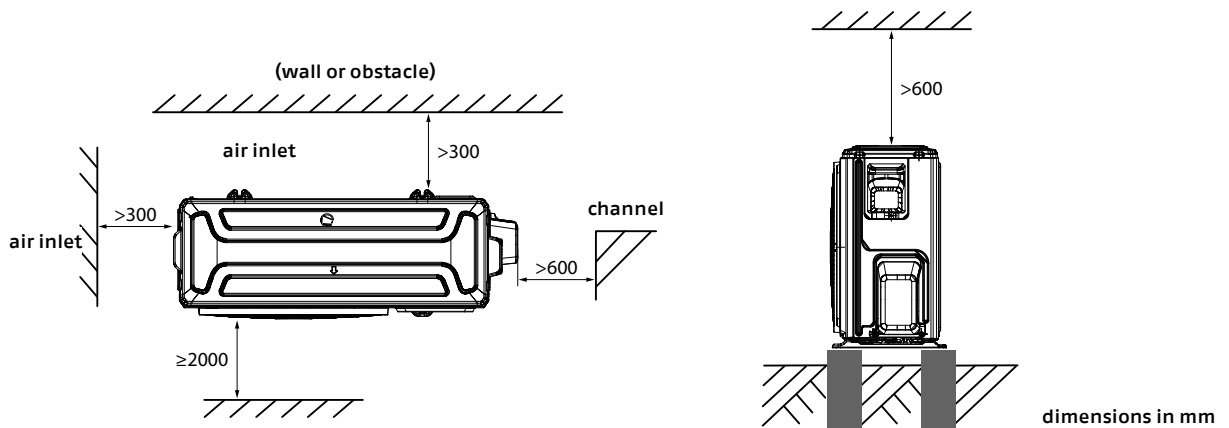

Prevention of snow accumulation

In case of snow, lift the unit above the base pad to prevent ice buildup and damage to the coil. Hung the unit high enough to exceed common snow accumulation, with a minimum height of 18 inches (approximately 45 cm).

In cold weather conditions

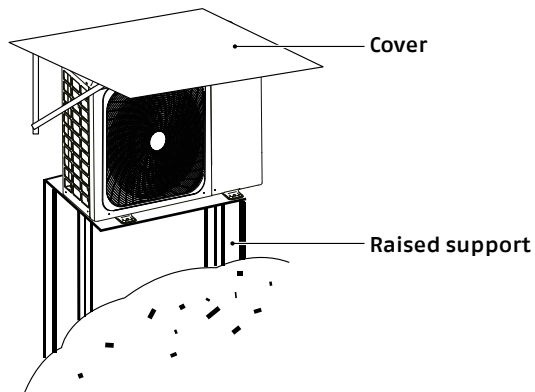

The image is purely indicative

SPECIAL CONSIDERATIONS FOR EXTREME WEATHER

If the unit is exposed to strong winds

Install the unit so that the air outlet fan is at a 90-degree angle to the wind direction. If necessary, build a barrier in front of the unit to protect it from extremely strong winds.

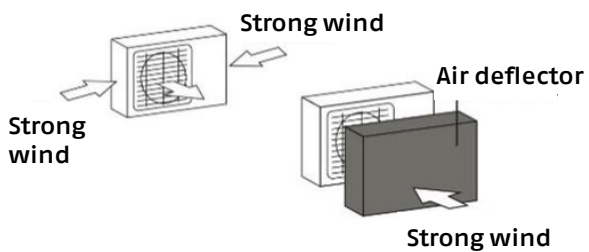

If the unit is often exposed to heavy rain or snow

Build a shelter over the unit to protect it from rain or snow. Be careful not to obstruct the airflow around the unit.

If the unit is often exposed to salty air (coastal locations)

Use an outdoor unit specifically designed to resist corrosion.

HYBRID SYSTEMS

Hybrid systems - Wall-hung solutions

SYSTEM LAYOUT

OUTDOOR UNIT

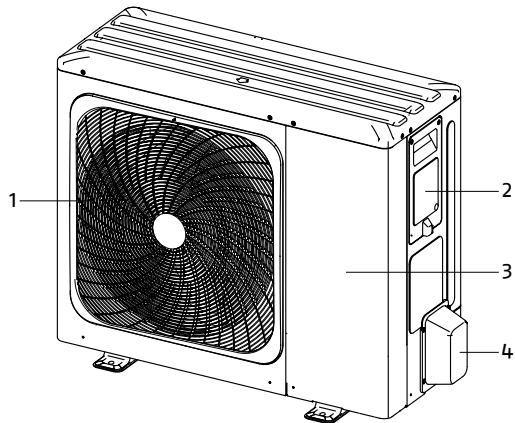

- 1 Electric fan grille
- 2 Electrical connection panel
- 3 Access panel
- 4 Hydraulic connection panel

The image is purely indicative

INDOOR UNIT

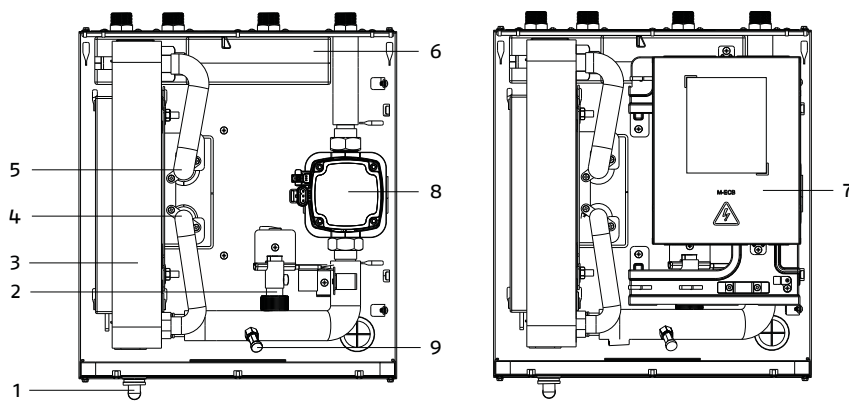

- 1 Drain pipe
- 2 Flow meter
- 3 Gas-water plate heat exchanger
- 4 Refrigerant liquid exchanger outlet
- 5 Refrigerant gas exchanger inlet
- 6 Hydraulic separator
- 7 Electrical connection box
- 8 Circulator (7 m)
- 9 Drain tap

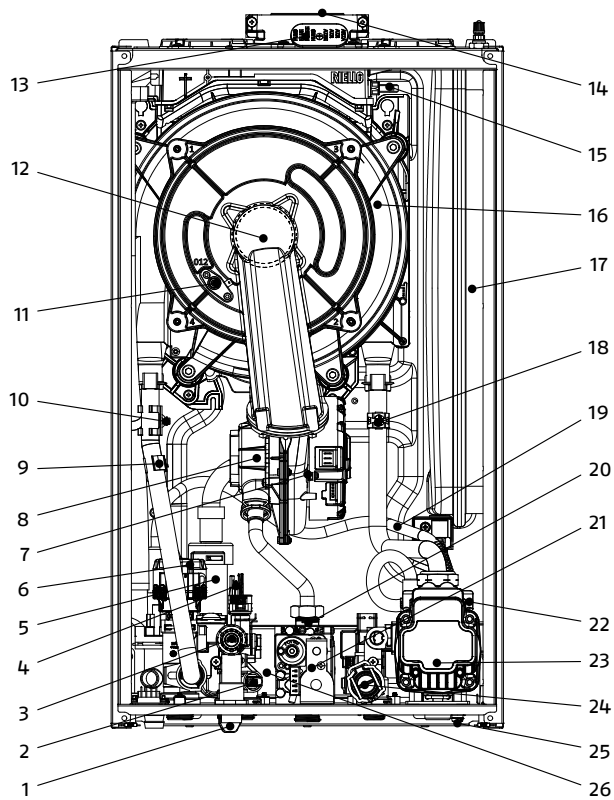
BOILER

- 1 Filling tap
- 2 DHW NTC probe
- 3 Safety valve
- 4 Pressure transducer
- 5 Siphon
- 6 Three-way valve
- 7 Fan
- 8 Mixer
- 9 NTC flow probe
- 10 Limit thermostat
- 11 Electrode
- 12 Burner
- 13 Flue gas air intake cap
- 14 Flue gas exhaust
- 15 Flue gas probe
- 16 Heat exchanger
- 17 Expansion vessel
- 18 NTC return probe
- 19 Degassing tube
- 20 Gas diaphragm
- 21 Gas valve
- 22 Air vent valve
- 23 Circulator
- 24 Flow meter
- 25 System drain tap
- 26 DHW exchanger

HYBRID SYSTEMS

Hybrid systems – Wall-hung solutions

HYDRAULIC CONNECTIONS

Riello ADAPTO 3.5

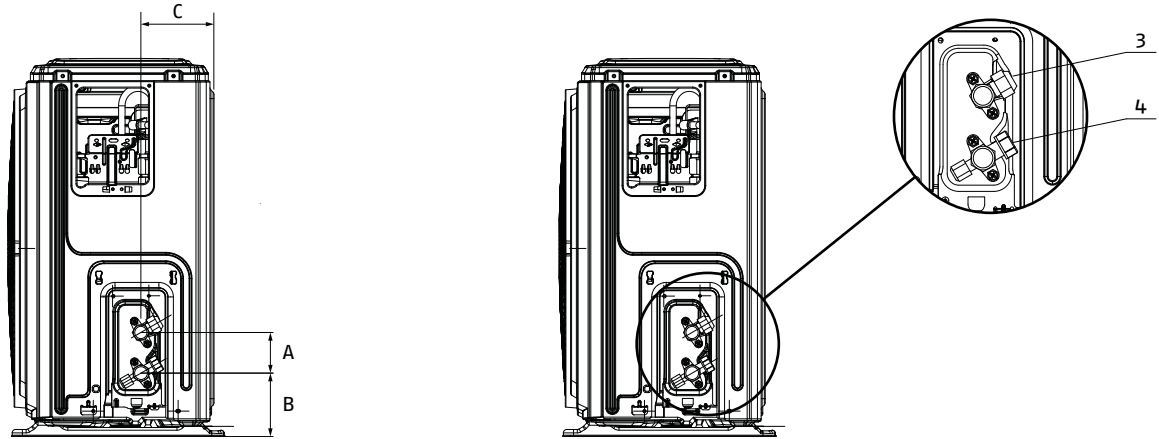

	DESCRIPTION	UoM	Riello ADAPTO 3.5	Riello ADAPTO 5.0*
1	Hole for electrical connections	∅ mm	-	-
2	Condensate drain hose connection (included)	∅ mm	-	-
3	Refrigerant gas connection	inches (SAE Flare)	∅ 3/8"	-
		mm	∅ 9,52	-
4	Refrigerant liquid connection	inches (SAE Flare)	∅ 1/4"	-
		mm	∅ 6,35	-
A		mm	56	-
B		mm	82	-
C		mm	100	-

(*) The 5.0 kW size not available at time of printing

RESIDUAL HEAD DIAGRAM – INDOOR UNIT

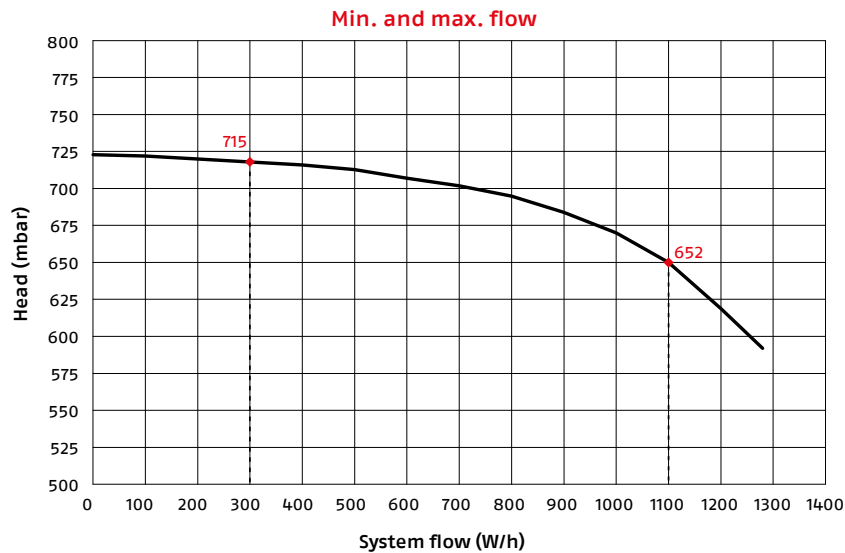

REFRIGERANT CONNECTIONS BETWEEN OUTDOOR UNIT AND INDOOR UNIT

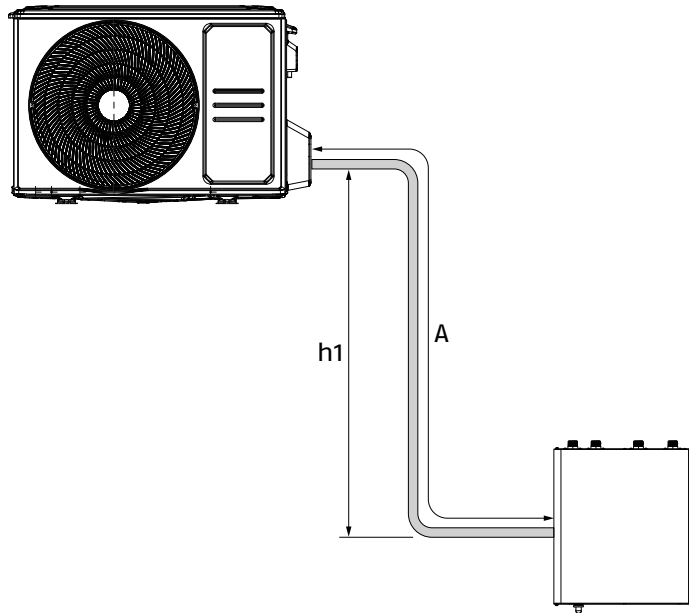

DESCRIPTION		UoM	3.5 kW	5.0 kW *
Min. length allowed in development	A	m	3	-
Max. length allowed in development	A	m	25	-
Elevation difference limit between the 2 units	h1	m	10	-
Length of the connection pipes without additional gas charge		m	5	-
Additional charge		g/m	12	-

(*) The 5.0 kW size not available at time of printing

HYBRID SYSTEMS

Hybrid systems – Wall-hung solutions

HYDRAULIC SYSTEM

WATER IN HEATING SYSTEMS

Before installation, the terminal and system must be cleaned and pressure tested as follows:

- Before connecting the equipment to the hydraulic system and the terminal, clean the hydraulic system and the terminal with clean water tap water at least 3 to 5 times until the waste water is free of impurities (UNI8065).
- If the system is installed on old systems, clean the system using appropriate products, the water in the system must be treated and comply with the UNI CTI 8065 2019 standard.

CHEMICAL-PHYSICAL CHARACTERISTICS

The chemical-physical features of the water must comply with the European standard EN 14868 and the tables below:

ALUMINUM GENERATORS with Firebox Power < 150 kW			
		First filling water	Fully operational water (*)
ph		-	7-8
Hardness	°F	< 15°	-
appearance		clear	-
Iron	mg/kg	-	< 0,5
Copper	mg/kg	-	<0,1

(*) System water values after 8 weeks of operation.

NEW HEATING SYSTEMS

The first filling of the system must be done slowly; once filled and deaerated, the system should not need any further refilling. During the first start-up, the system must be brought to its maximum operating temperature to facilitate deaeration (too low a temperature prevents the escape of gases).

RETROFITTING OF EXISTING HEATING SYSTEMS

When replacing a boiler, if the water quality in existing systems complies with the requirements, refilling is not recommended. If the water quality does not comply with the requirements, water reconditioning or system separation is recommended (water quality requirements must be met in the boiler circuit).

SYSTEM WATER CONTENT AND FLOW

- Always ensure a minimum flow of 300 l/h when there is an active heating/cooling demand.
- If the system volume is less than 20 litres, we recommend installing an accumulator on the heating system return (optional kit available on request).

ELECTRICAL CONNECTIONS

BOILER

The START KIS boiler leaves the factory fully wired. The following connections are sufficient:

- to the single-phase 230V-50Hz mains supply, using the cable provided;
- to the 485 Bus (- A B +);
- to the low temperature thermostat (TBT);
- to the room thermostat (TA/OT+) - dry contact (OpenTherm);
- to the external probe (SE).

The connection to the mains must be made via a separation device with an omnipolar opening of at least 3.5 mm (EN 60335-1, category III). The appliance operates on 230 Volt/50 Hz alternating current and complies with EN 60335-1.

If replacing the power cable, use a HAR H05V2V2-F type cable, 3 x 0,75 mm², max. external diameter 7 mm.

It is mandatory:

- to use an omnipolar magnetothermic switch, a feeder disconnecter, compliant with CEI-EN standards (contact opening of at least 3mm);
- to respect the W (Phase) and N (Neutral) connections;
- to use cables with a cross-section greater than or equal to 1,5 mm², complete with terminal lugs.
- to establish an effective ground connection.

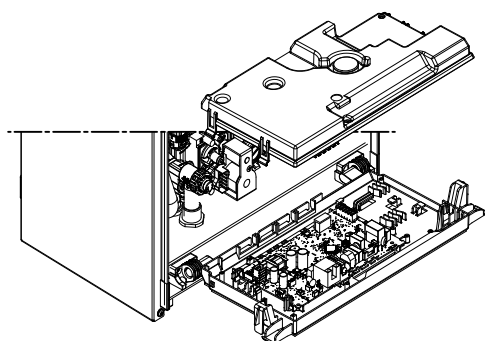

CE4 ModBus
removable
connector

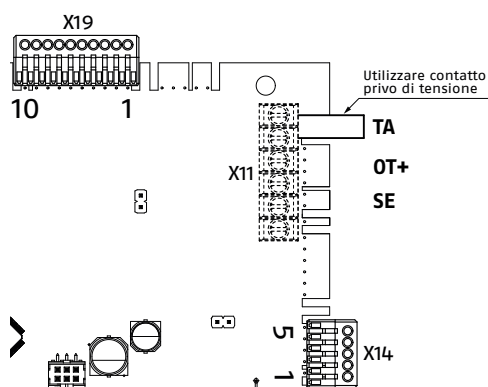
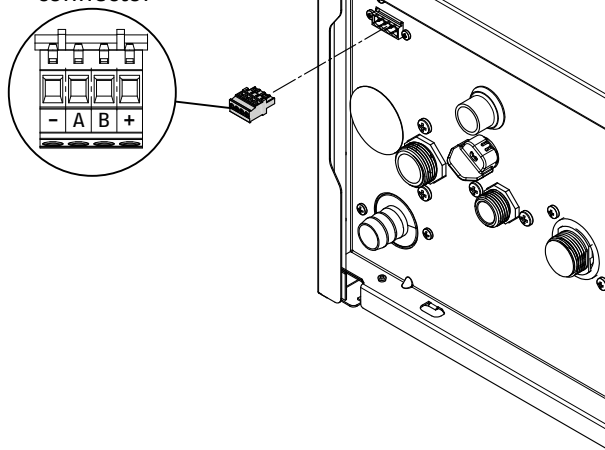

HYBRID SYSTEMS

Hybrid systems – Wall-hung solutions

OUTDOOR AND INDOOR UNIT

Instructions for electrical power connections

It is necessary to install an omnipolar switch with:

- an opening > 3 mm;
- a breaking capacity ≥ 16 A;
- an outdoor unit power supply conductor cross-section ≥ 1,5 mm².
- a modBus communication cable cross-section 0,75 mm²

The power supply for the indoor unit is taken from the outdoor unit (conductor cross-section ≥ 0.5 mm²).

Prepare the power and signal cable (not included as standard) between the outdoor unit and the indoor unit terminal block.

Connect the Modbus cable (not included as standard) to the CE4 connector on the boiler, the CN86 connector on the indoor unit, and the T300-Hy.

The recommended total length for the connection between the T300-Hy, boiler, and hydraulic module is ≤ 30 m (use shielded cable).

CONTROL PANEL

Refer to the wiring diagram below for specific instructions on the electrical connections to be made.

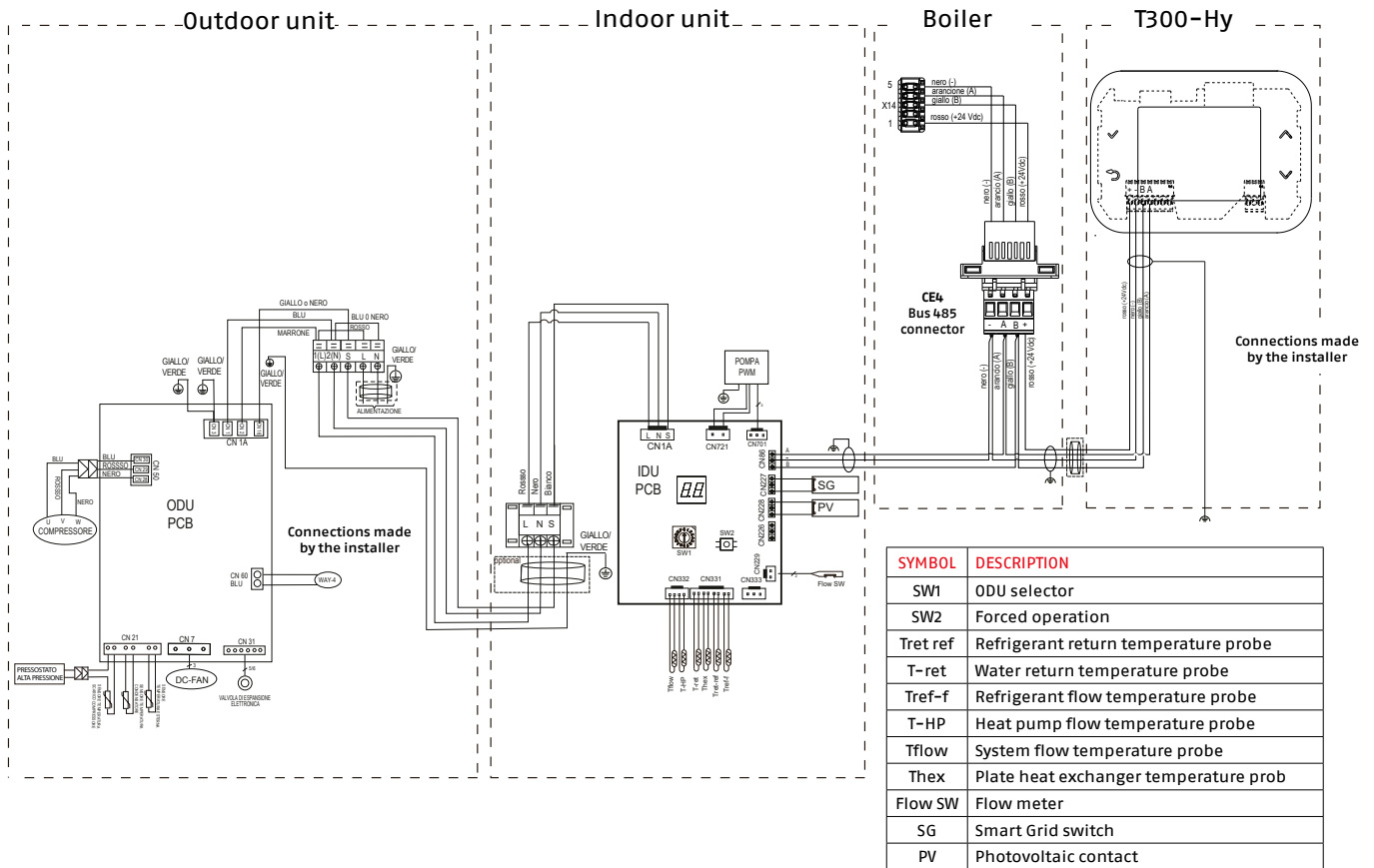

CONTROL PANEL

GENERAL INFORMATION



The T300-Hy is the system's user interface and the device that houses the system optimization logic. At the same time, it can be used to control the room temperature of the area in which it is installed.

When used as a machine interface, the device mainly manages the operation of the system components. Heating and cooling requests are managed using an external room thermostat or T200 connected via radio frequency.

When used as a machine interface + room control, in addition to its system interface functions, the device can also regulate the temperature of the room in which it is installed.

The touch interface of the Hi, Comfort T300-Hy is extremely simple and intuitive. The icon display and drop-down menus are elements that promote smart use of the product.

The four side buttons described below allow you to easily perform all the operations necessary for programming and customizing the device.

SYMBOL	DESCRIPTION
	Confirm
	Delete Return to the main screen (press > 2 second) Reset anomaly
	Browsing within a menu - scroll up
	Browsing within a menu - scroll down

When paired with the T300-Hy RF, the Hi, Comfort T200 Thermostat allows for optimal control of comfort within each room of the home, managing up to a maximum of 8 zones, including the main one.

HYBRID SYSTEMS

Hybrid systems – Wall-hung solutions

CONSTRUCTION DESCRIPTION FOR SPECIFICATIONS

RIELLO ADAPTO is the R32 electric heat pump outdoor unit specially designed for use in residential hybrid applications. It can be used in combination with the HYBRID HYDRAULIC KIT indoor unit, which allows it to operate in conjunction with the range of combi boilers START.

RIELLO ADAPTO contributes to heating requirements simultaneously with the boiler or alternately, depending on the type of optimization set by the user via Hi, Comfort T300-Hy, the hybrid system's energy manager. If the system has fan coils, RIELLO ADAPTO can also meet cooling requirements.

It is designed to be installed outside the home, on the floor or wall-hung with suitable support brackets (not supplied as standard). The condensate drain connection and anti-vibration mounts are supplied with Riello ADAPTO.

The HYBRID HYDRAULIC KIT is the indoor unit of the split heat pump that allows the latter to be integrated with the boiler. The hydraulic kit is to be housed inside the home, suspended below the boiler or to the side of it, at a distance equivalent to a linear pipe with a 3/4" section not exceeding 15 meters on the supply side and 15 meters on the return side.

The connection ramps between the Hydraulic Kit and the boiler are not included as standard. The HYBRID HYDRAULIC KIT comes with a 90° gas connection pipe, a 90° liquid connection pipe, a drain nozzle/water outlet pipe, a drain nozzle gasket, a condensate drain pipe, two expansion plugs, and four 3/4" gaskets.

The management of the available heat sources (boiler and heat pump), the system circulator, all the electric actuators, and the regulation of the heating or cooling temperatures is carried out through the intrinsic logic of the system electronics and the T300-Hy.

The hybrid system is programmed and controlled via the T300-Hy remote control, which, when suitably programmed, can also be used as a room thermostat for the area in which it is installed.

FEATURES

- RIELLO ADAPTO and HYBRID HYDRAULIC KIT, in combination with HI, COMFORTT300-I, and a combined model from the START range, constitute Riello's factory-made multi-energy residential system that meets the needs of heating, cooling (hydronic), and domestic hot water production in a single system for year-round home comfort. The system achieves energy efficiency class A++ / A+ for heating (for average climatic conditions, 55°C and 35°C respectively) and energy efficiency class A for domestic hot water.
- Compact and versatile solution designed to adapt to multiple system requirements, minimizing space requirements inside and outside the home: small hydronic kit that can be easily positioned either below or to the side of the boiler, up to a maximum distance of 15m; heat pump synonymous with compactness, with the option of floor or wall mounting with suitable support brackets, up to a maximum distance of 25m in length and 10m in height from the indoor unit.
- Plug&Play technology for simple, quick and flexible installation.
- Proprietary system intelligence stored in the system interface and also remotely manageable via the Hi, Comfort App.
- Attention to user needs and choice between economic optimization mode, for savings on energy bills, or eco mode, to help reduce CO₂ emissions.

OUTDOOR UNIT COMPONENTS

- Pre-painted sheet metal cover
- ABS flow grille
- Electric fan unit consisting of helical fan and motor with adjustable speed
- Exchange coil consisting of copper tubes and turbulent aluminum fins. The coils are treated against saltiness by two coatings: a layer of acrylic resin and a second layer of hydrophilic material
- GMCC (Guangdong Meizhi Compressor Ltd) R32 rotary compressor mounted on anti-vibration supports and located in a special compartment
- Axial Flow Fan
- Microprocessor control board with PWM + PAM DC inverter regulation system in direct current.
- Bidirectional electronic expansion valve
- Extended operating range for temperatures -15/+24°C in heating mode and 10/50°C in cooling mode
- Complete outdoor unit with connection covers

INDOOR UNIT COMPONENTS

- Covering unit in white pre-painted sheet metal
- Side pre-cuts to facilitate the connection of refrigerant pipes
- Hydraulic connections: flow to system, flow from boiler, return to boiler, return from system
- Drain pipe for condensation that may form during cooling
- Flow meter
- Gas-water plate heat exchanger
- Electrical connection box
- 7m circulator with PWM control system
- System water drain tap
- Temperature sensors: heat pump flow, refrigerant gas, system return, refrigerant liquid, gas-water exchanger and flow

BOILER COMPONENTS

START is a type C wall-hung condensing boiler for heating and domestic hot water production: depending on the flue gas exhaust accessory used, it is classified in categories B23P; B53P; C13, C13x; C33, C33x; C43, C43x; C53, C53x; C83, C83x; C93, C93x.

Wall-hung condensing boilers, with primary heat exchanger in AISI 441 stainless steel and pneumatic combustion system that guarantees functionality, efficiency, and low emissions in all circumstances.

1:8 modulation across the entire range.

START can be installed indoors or outdoors in a partially protected location, i.e., in a place where the boiler is not exposed to direct action and infiltration of rain, snow, or hail. The boiler can operate in a temperature range from 0°C to +60°C.

Class 6 NOx according to UNI EN 15502-1.

New easy-to-use and functional touchscreen control panel.

The boilers in the START range are heat generators characterized by:

- A pneumatic combustion system that guarantees functionality, efficiency, and low emissions in all circumstances; designed to operate with blends of natural gas and up to 20% hydrogen. The 25 kW models are also approved for operation with propane air.
- Maximum heat output adaptable to the heat requirements of the system, for heating operation of the boiler itself. Once the desired power (maximum heating) has been set, report the value and, for subsequent checks, refer to the new value.
- High-efficiency ON/OFF circulator already connected hydraulically and electrically, factory set with a 6-metre head curve; 7-metre circulator available as an accessory.
- Anti-locking system that starts an operating cycle every 24 hours of inactivity with the function selector in any position.
- Main circular heat exchanger in AISI 441 stainless steel.
- Low-pollution premix burner, Class 6 NOx, according to UNI EN 15502-1), fan, high modulation mixer, and gas diaphragm. Available as an accessory kit with non-return valve (clapet) for connection to positive pressure flue systems.
- Available as an accessory kit with air filter integrated into the boiler, consisting of a filter made of elastic, break-resistant polyolefin fibers.
- Hydraulic connections with DIN-type connection sequence and specific accessories in case of replacement with old boilers.
- Filling valve, deaeration valve.
- Siphon with safety ball inside the boiler footprint.
- Drain valve.
- Pressure transducer.
- Safety valve.
- Return probe, flue gas probe, and Flow probe.
- Automatic antifreeze system, which activates when the primary circuit water temperature drops below 5°C. This system is always active and guarantees protection of the boiler up to an air temperature in the installation site of 0°C.
- Limit thermostat.
- Flame detection electrode.
- Ignition transformer.
- Prepared with flue gas analysis socket cap.
- 8-litres expansion vessel.
- Hydraulic three-way valve (stepper).
- DHW exchanger with brazed plates designed and made in RIELLO with high efficiency which allows the production of domestic hot water in condensation mode and with maximum stability.

HYBRID SYSTEMS

Hybrid systems – Wall-hung solutions

- Manual filling valve.
- Hydrometer.
- Lower air vent valve.
- Touchscreen control panel with machine interface function, displaying system settings and allowing access to parameters. The main screen shows the temperature of the domestic hot water sensor in the center, unless a heat request is in progress, in which case the boiler flow temperature, the water pressure in the system, and information relating to the current date and time are displayed, as well as the outdoor temperature, if available.
- OT+ input as standard.

CONTROL PANEL

The unit's user interface, called Hi, Comfort T300-HY, can be remote-controlled. This interface can be installed at a maximum distance of 30 m. It is connected to the control unit by a 3 x 0,35 mm² shielded cable. It is an extremely simple and intuitive interface designed to be used by the system user to set the operating temperatures of the heating, air conditioning, and domestic hot water tank systems.

RIELLO ADAPTO HYBRID complies with the following directives

- LVD: 2014/35/EU Low Voltage Directive
- EMC: 2014/30/EU Electromagnetic Compatibility Directive
- ErP: 2009/125/EC: Energy-related Products Directive
- PED: 2014/68/EU: Pressure Equipment Directive
- REACH: 1907/2006: Regulation on the Registration, Evaluation, Authorization, and Restriction of Chemicals
- RoHS: 2011/65/EU: Restriction of Hazardous Substances in Electrical and Electronic Equipment
- RED 2014/53/EU: Radio Equipment Directive
- GAR 2016/426/EU: European regulation on gas appliances

SYSTEM EXAMPLE

HEATING, COOLING, AND DHW SYSTEM WITH HEAT PUMP, HYDRAULIC KIT, AND COMBINED BOILER

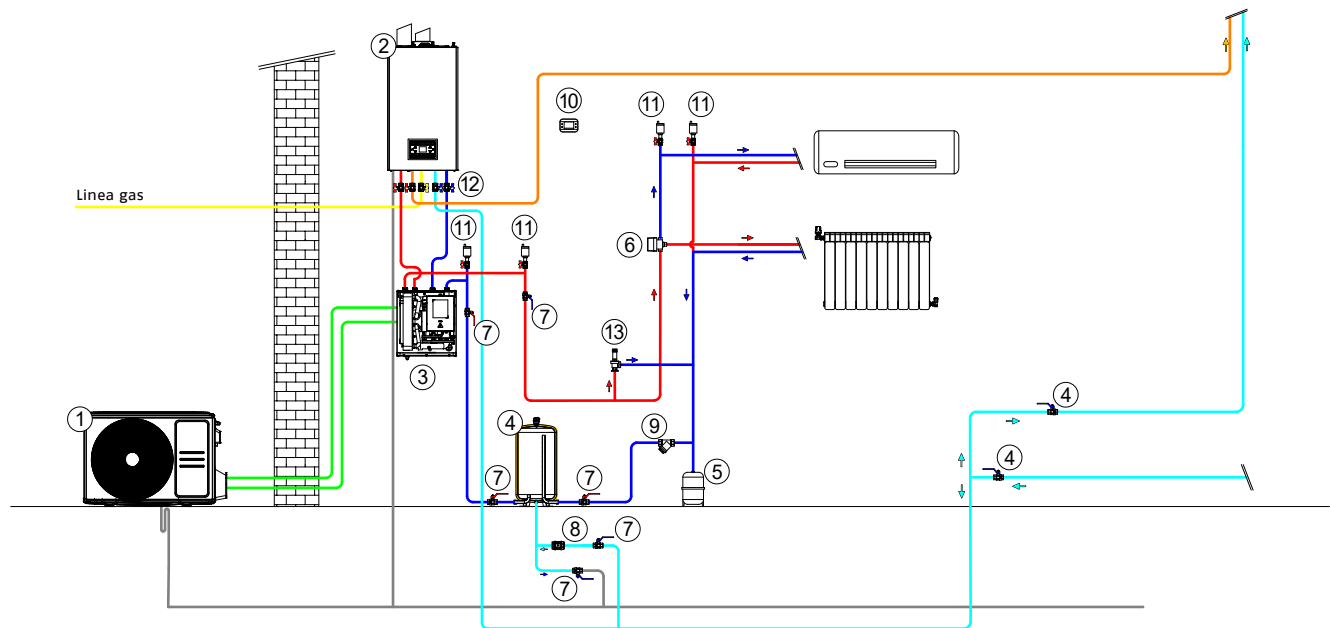

- | | |
|---|----------------------------|
| 1 Heat pump outdoor unit | 8 Non-return valve |
| 2 Boiler with circulator and vessel | 9 Filter |
| 3 Heat pump indoor unit | 10 T300-Hy control panel |
| 4 Inertial storage | 11 Deaerator |
| 5 Expansion vessel | 12 Under-boiler tap kit |
| 6 Summer-winter diverter valve ^(*) | 13 Adjustable bypass valve |
| 7 Globe valve | |

(*) Management is handled by the installer.

RIELLO

RIELLO S.p.A.
37045 Legnago (VR) Italy
tel. +39 0442 630111



RIELLO
ADAPTO HYBRID

www.riello.com



Riello reserves the right to change the information and specifications contained herein at any time without notice. The contents and information provided herein are for informational purposes only and are not intended to provide legal or professional advice. This document, therefore, cannot be considered binding on third parties



©2025 Carrier. All rights reserved.
All product and service trademarks mentioned in this document are the property of their respective owners.