

# INSIEME EVO COND 45-55-70 LN

EN INSTALLATION AND MAINTENANCE MANUAL

# RIELLO

## RANGE

MODEL	CODE
INSIEME EVO COND 45 LN	20145977
INSIEME EVO COND 55 LN	20145978
INSIEME EVO COND 70 LN	20145979

## ACCESSORIES

For a complete list of accessories and details of their compatibility, refer to the Catalogue.

## CONFORMITY

Thermal units **INSIEME EVO COND LN** comply with:

- Directive 92/42/EEC on efficiency requirements
- Electromagnetic Compatibility Directive 2014/30/EU
- Low Voltage Directive 2014/35/EU
- Ecodesign Directive 2009/125/CE for energy-related products
- Regulation (EU) 2017/1369 Energy labelling
- Delegated Regulation (EU) N. 811/2013
- Delegated Regulation (EU) N. 813/2013

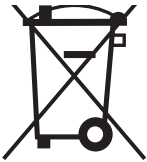

At the end of its life, the product should be not be disposed of as solid urban waste, but rather it should be handed over to a differentiated waste collection centre.

Dear heating engineer,  
Congratulations on having chosen a **RIELLO** boiler. You have selected a modern, quality product that is designed to give dependable, efficient and safe service and to provide comfort in the home for many years to come.

This manual provides information that is essential to the installation of the appliance. Used in conjunction with your own knowledge and expertise it will enable you to install the appliance quickly, easily, and correctly.

Please accept our thanks and our congratulations on your choice of product.  
Riello S.p.A.

# CONTENTS

<b>1 GENERAL INFORMATION</b> .....	<b>4</b>	<b>3 COMMISSIONING AND MAINTENANCE</b> .....	<b>51</b>
1.1 General Safety Information .....	4	3.1 Preparing for initial startup .....	51
1.2 Precautions .....	4	3.2 Initial startup .....	51
1.3 Description of the appliance .....	4	3.2.1 Adjustment of heating setpoint .....	52
1.4 Safety and control devices .....	5	3.2.2 Enable/disable the heating function .....	52
1.5 Identification .....	5	3.2.3 Enable/disable the domestic function .....	52
1.6 System layout .....	6	3.2.4 Adjustment of domestic setpoint .....	53
1.7 Technical specifications .....	9	3.2.5 Setting the heating parameters .....	53
1.8 Location of sensors .....	12	3.2.6 Setting the domestic hot water parameters .....	56
1.9 Control panel .....	13	3.2.7 Heat request priority .....	57
<b>2 INSTALLATION</b> .....	<b>15</b>	3.2.8 Special functions .....	57
2.1 Unpacking the product .....	15	3.2.9 Flow meter parameters configuration (accessory) .....	58
2.1.1 Positioning of labels .....	15	3.2.10 Flow switch configuration .....	58
2.2 Overall dimensions and weights .....	15	3.2.11 Ignition failure .....	59
2.3 Moving and removing the packing .....	16	3.3 Checks during and after initial start-up .....	59
2.4 Installation premises .....	17	3.4 Single-stage burner .....	60
2.4.1 Recommended minimum distances .....	17	3.4.1 Burner control and adjustment .....	60
2.5 Installation in older systems and systems requiring modernisation .....	17	3.4.2 Burner functioning and programming .....	61
2.6 Water connections .....	18	3.5 Two-stage burner .....	69
2.7 Boiler water circuit .....	18	3.5.1 Burner control and adjustment .....	69
2.8 Source water systems and configurations .....	19	3.5.2 Burner functioning and programming .....	70
2.9 Fuel connections .....	25	3.6 Error List .....	80
2.9.1 Dual-pipe system .....	26	3.6.1 Permanent Errors .....	80
2.9.2 Single-pipe system .....	27	3.6.2 Temporary Errors .....	80
2.10 Discharge of combustion products .....	28	3.6.3 Warnings .....	80
2.10.1 Technical specifications of stack .....	28	3.7 Temporary or short-term shut-down .....	81
2.10.2 Connection to the stack .....	28	3.8 Preparing for extended periods of disuse .....	81
2.10.3 Preparation for the condensate drain .....	31	3.9 Device cleaning and maintenance .....	81
2.10.4 Neutralising the condensate .....	31	3.10 Annual cleaning .....	81
2.11 System filling and emptying .....	32	3.10.1 Cleaning and maintaining the burner .....	81
2.11.1 Water quality requirements .....	32	3.10.2 Boiler exchanger cleaning .....	85
2.11.2 Filling .....	33	3.10.3 Condensate drain siphon cleaning .....	87
2.11.3 Emptying .....	33	3.11 External cleaning .....	87
2.12 Wiring diagram .....	34	3.12 Troubleshooting .....	88
2.12.1 Burner wiring diagram .....	35	<b>4 SYSTEM MANAGER</b> .....	<b>91</b>
2.12.2 Burner wiring diagram .....	37	4.1 Putting into service .....	91
2.13 Electrical connections .....	38	4.2 Temporary or short-term shut-down .....	92
2.14 Menu navigation .....	40	4.3 Preparing for extended periods of disuse .....	92
2.15 Enter password .....	41	4.4 Cleaning .....	92
2.16 Navigation scheme .....	42	4.5 Maintenance .....	92
2.17 List of parameters .....	43	4.6 Useful information .....	93
		<b>5 RECYCLING AND DISPOSAL</b> .....	<b>94</b>

The following symbols are used in this manual:











 **CAUTION!** = Identifies actions that require caution and adequate preparation.

 **STOP!** = Identifies actions that you MUST NOT do.

This manual, Code 20152322 – Rev. 7 (07/2025) comprises 96 pages.















## 1 GENERAL INFORMATION

### 1.1 General Safety Information

-  After removing the packaging, check the condition and completeness of the supply. If there are any problems, contact the company **RIELLO** that sold the equipment.
-  This product must be installed by a legally qualified heating engineer. On completion of the installation, the installer must issue the owner with a declaration of conformity confirming that the installation has been completed to the highest standards in compliance with the instructions provided by **RIELLO** in this instruction manual, and that it conforms to all applicable laws and standards.
-  This product must only be used for the purpose for which it is designed and made, as specified by **RIELLO**. **RIELLO** declines all responsibility, contractual or other, for damage to property or injury to persons or animals caused by improper installation, adjustment, maintenance or use.
-  The room where the boiler is installed must be properly ventilated to ensure a sufficient supply of air for correct combustion.
-  In case of water leaks disconnect the equipment from the power mains, close the water supply and promptly alert Technical Assistance Service **RIELLO** or professionally qualified personnel.
-  Regularly check that the condensate drain is free from obstruction.
-  The boiler must be serviced at least once a year. The failure to perform annual maintenance work will void the warranty of the equipment.
-  Periodically check that pressure in the central heating circuit, when cold, is approximately 1.5 bar and below the maximum limit specified for the boiler. If this is not the case, contact the Technical Assistance Service **RIELLO** or professionally qualified personnel.
-  If the boiler is not going to be used for an extended period of time, perform the operations described later in this manual.
-  This manual is an integral part of the equipment and therefore must be stored carefully and must **ALWAYS** accompany the boiler even if it is sold to another Owner or User or transferred to another plant. If it is damaged or lost, request another copy from your local Technical Assistance Service **RIELLO**.
-  This manual must be read carefully so as to ensure the correct and safe installation, operation and maintenance of the appliance. The Owner must be adequately informed and trained on how to operate the appliance. Make sure that he/she is familiar with all the information required for safe system operation.

### 1.2 Precautions

The operation of any appliance that uses fuel, electrical power and water demands that a number of fundamental safety precautions be respected:

-  Do not allow children or infirm persons to operate the system unsupervised.
-  It is forbidden to use electrical devices or equipment, such as switches, appliances, etc. if there is a smell of gas or unburnt products. If so:
  - Ventilate the room, opening doors and windows
  - Close the fuel shut-off cock
  - Ask for the prompt intervention of the Technical Assistance Service
-  Do not touch the boiler while barefoot or wet.
-  Any technical or cleaning operation is forbidden before:
  - removing the power supply by setting the main switch of the equipment to (I) and the main switch of the system to (OFF)
  - closing the water and fuel shut-off valves
-  Do not tamper with or adjust the safety or control devices without prior authorisation and instructions from the manufacturer.
-  Do not plug or block the condensate drain outlet.
-  Never pull, disconnect, or twist the electrical cables coming from the appliance even if it is disconnected from the mains electricity supply.
-  Do not obstruct or restrict the vents in the room where the boiler is installed. Adequate ventilation is essential for correct combustion.
-  Do not expose the boiler to the elements. It is not designed for use outdoors.
-  Do not switch off the appliance if the outdoor temperature may drop to below ZERO (frost hazard).
-  It is prohibited to leave inflammable substances and containers in the room where the boiler is installed.
-  Do not dispose of packaging material into the environment, or leave it within the reach of children, since it can become a potential hazard. Dispose of packaging material in compliance with applicable legislation.
-  It is forbidden to operate the boiler without water.
-  The equipment casing must not be removed by people without specific qualification and expertise.

### 1.3 Description of the appliance

The light oil condensing thermal unit **INSIEME EVO COND LN** is a hot water generator for the heating of environments. It can function at low temperature and is oil fuelled. The steel combustion chamber is horizontal and the low NOx burner features a single-stage operation for the 45 LN model and two-stage for the 55 LN and 70 LN models. The boiler unit is effectively and accurately insulated with a high-density glass wool mat. The control panel includes a user interface with display and an electronic board for the thermal unit adjustment and control, which allows to manage the control and safety devices in compliance with the regulations in force.



1.6 System layout

INSIEME EVO COND LN

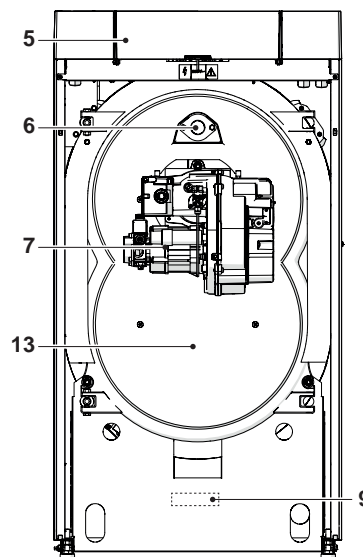
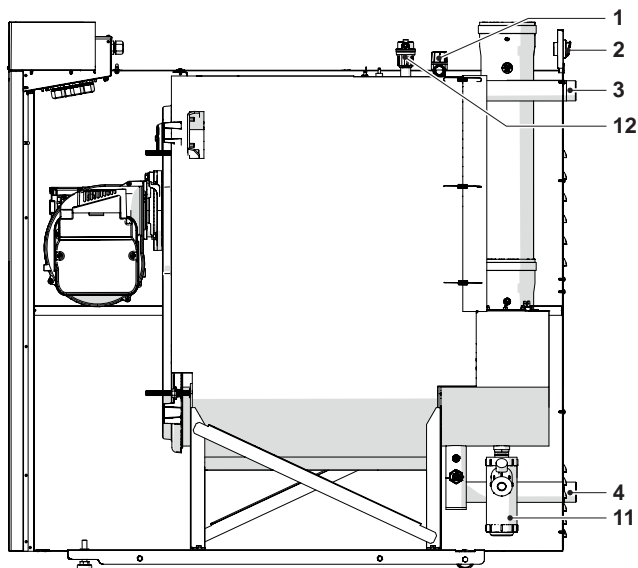

- 1 Safety valve
- 2 Main switch
- 3 Central heating flow
- 4 Central heating return
- 5 Control panel
- 6 Flame inspection window
- 7 Burner
- 8 Boiler body
- 9 Serial number plate
- 10 Exhaust flue duct
- 11 Condensate drain siphon
- 12 Automatic bleed valve
- 13 Flue gas box cover

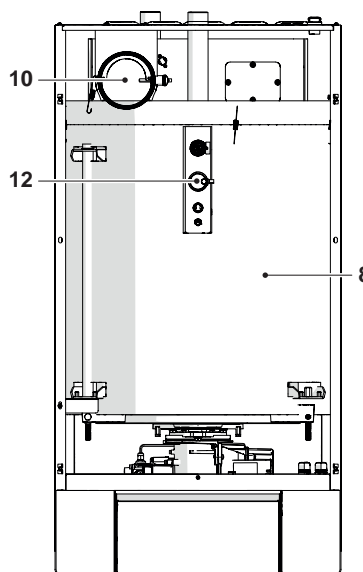

Used in the model **INSIEME EVO COND 45 LN**  
**SINGLE-STAGE BURNER**

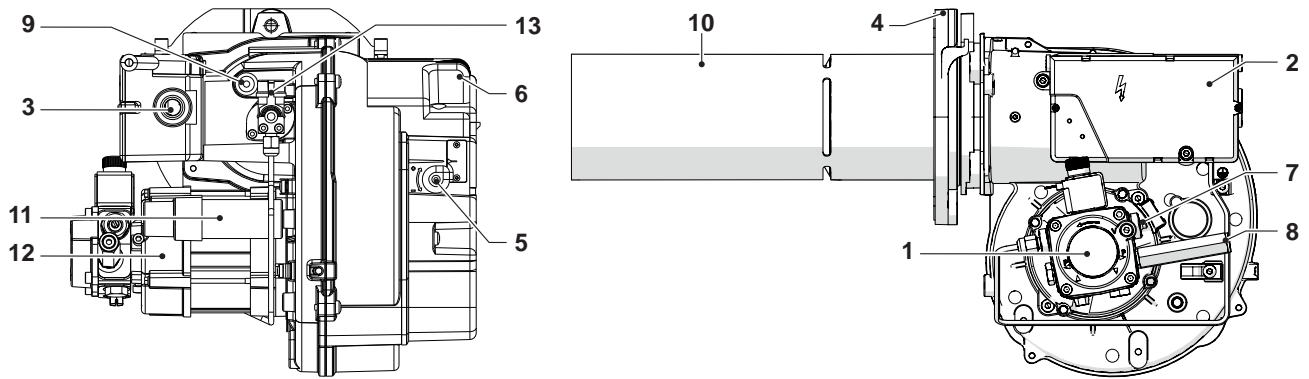

- 1 Pump
- 2 Burner controller
- 3 Reset button with lockout indicator
- 4 Flange with seal
- 5 Air damper adjuster screw
- 6 Air intake
- 7 Oil pump pressure adjuster screw
- 8 Pressure gauge fitting
- 9 Photoresistor
- 10 Flame pipe
- 11 Condenser
- 12 Motor
- 13 Heating element

**OIL PUMP**

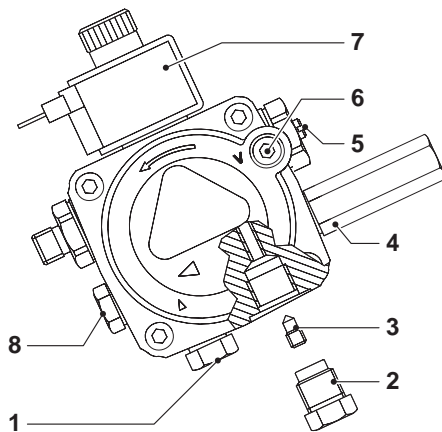

- 1 Suction port
- 2 Return
- 3 By-pass screw
- 4 Pressure gauge fitting
- 5 Pressure adjuster screw
- 6 Vacuum gauge fitting
- 7 Solenoid valve
- 8 Auxiliary pressure measurement fitting

**TWO-STAGE BURNER**

Used in the models **INSIEME EVO COND 55 LN** and **70 LN**

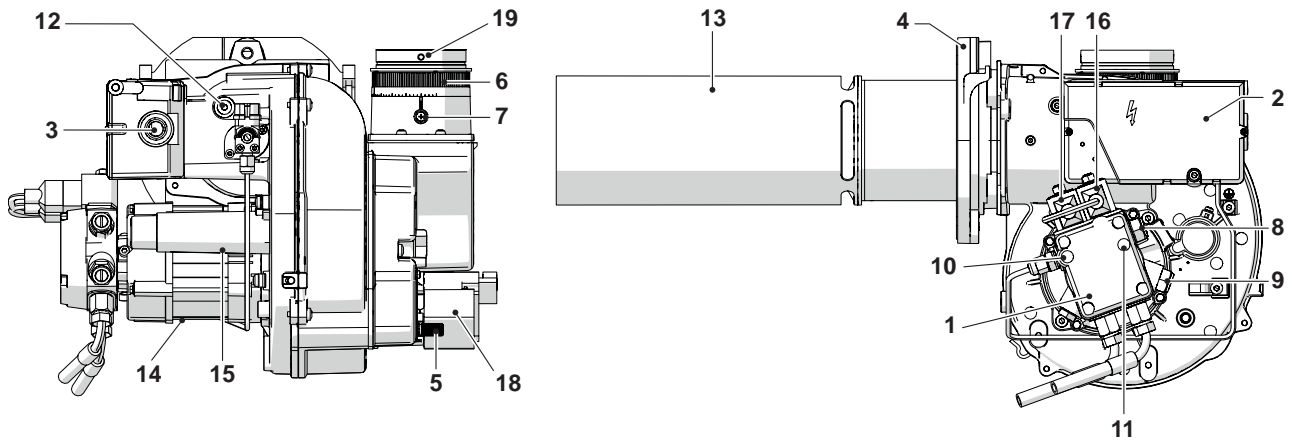

- |  |                   |
|--|-------------------|
| 1 Pump                                     | 12 Photoresistor  |
| 2 Burner controller                        | 13 Flame pipe     |
| 3 Reset button with lockout indicator      | 14 Motor          |
| 4 Flange with seal                         | 15 Condenser      |
| 5 1st stage air damper adjustment          | 16 1st stage coil |
| 6 2nd stage air damper adjustment          | 17 2nd stage coil |
| 7 Air damper fastening screw               | 18 Air servomotor |
| 8 1st stage pump pressure adjustment screw | 19 BF air intake  |
| 9 2nd stage pump pressure adjustment screw |                   |
| 10 Pressure gauge fitting                  |                   |
| 11 Vacuum gauge fitting                    |                   |

**OIL PUMP**

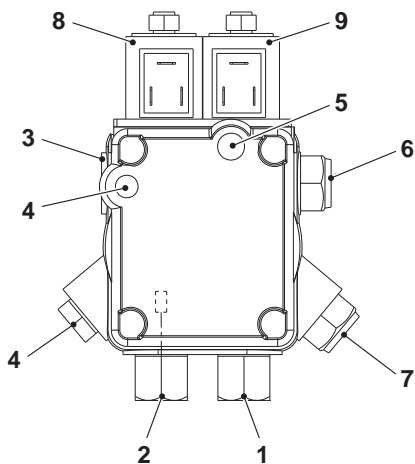

- |                                 |
|---------------------------------|
| 1 Suction port                  |
| 2 Return                        |
| 3 Outlet at the nozzle          |
| 4 Pressure gauge fitting        |
| 5 Vacuum gauge fitting          |
| 6 1st stage pressure adjustment |
| 7 2nd stage pressure adjustment |
| 8 1st stage valve               |
| 9 2nd stage valve               |

## 1.7 Technical specifications

DESCRIZIONE			INSIEME EVO COND			
			45 LN	55 LN	70 LN	
Device type			Space-heating condensing appliance B23-B23P-C13(*)-C33(*)-C63(*)			
Fuel			Heating fuel oil (light oil)			
Combustion chamber			Horizontal			
Maximum rated heat input at furnace referred to HVC (LCV)			47,7 (45)	58,3 (55)	74,2 (70)	kW
Minimum rated heat input at furnace referred to HVC (LCV)			47,7 (45)	42,4 (40)	58,3 (55)	kW
Useful (rated) heat output			44	53	68	kW
Maximum useful heat output	P4	(80-60°C)	43,7	53,3	67,7	kW
Maximum rated heat output (50-30°C)	-	OIL	46,7	57,2	72,8	kW
Maximum nominal heat output (60-40°C)	-	OIL	45,5	55,4	70,4	kW
30% heat output	P1	with return 30°C	14,2	17,3	22,0	kW
Minimum rated heat output (80-60°C)	-	OIL	43,7	38,9	53,4	kW
Minimum nominal heat output (50-30°C)	-	OIL	46,7	41,8	57,4	kW
Efficiency class in central heating mode			A	A	A	
Seasonal energy efficiency in central heating mode	ηs		93	93	93	%
Efficiency at rated heat output in high temperature mode referred to HCV	η4	Pn (80-60°C)	91,7	91,4	91,3	%
Efficiency with nominal heat output and high temperature referred to LHV			97,2	96,9	96,8	%
Efficiency at 30% rated heat output in low temperature mode referred to HCV	η1	with return 30°C	98,9	98,9	98,9	%
Efficiency at 30% with nominal heat output and low temperature referred to LHV			104,8	104,9	104,8	%
Chimney losses with burner on at max. Pn (80-60°C)			2,4	2,5	2,6	%
Chimney losses with burner on at max. 30% Pn (50-30°C)			0,2	0,2	0,2	%
Heat loss in standby mode	Pstby		220	320	475	W
			0,5	0,6	0,7	%
Annual energy consumption	QHE		140	170	217	GJ
Noise level (sound power)	LWA		77	77	77	dB(A)
Emissions with maximum output (*)	NOx	(referred to HCV)	93	86	97	mg/kWh
	NOx Class		4	4	4	n°
	CO2		12,5	12,5	12,5	%
	CO w.a. <		12	10	8	ppm
	Flue gas T	with nominal output (80-60°C)	67	67	69,1	°C
Smoke scale			<0,5	<0,5	<0,5	
Flue gas mass airflow with max nominal output (**)			20	24	31	g/s

LCV: Lower calorific value of fuel

HCV: Higher calorific value of fuel

Test conditions:

- Room temperature 22°C
- Atmospheric pressure 1018 mbar

(\*) Configurations possible only with the installation of the dedicated accessories (available separately).

(\*\*) Values referred to atmospheric pressure at sea level.

DESCRIZIONE	INSIEME EVO COND			
	45 LN	55 LN	70 LN	
Flue gas residual head with max power	200	180	200	Pa
Minimum operating pressure	0,5			bar
Maximum working pressure	3			bar
Lockout thermostat activation temperature	110			°C
Maximum adjustment temperature	82	82	82	°C
Boiler water capacity	79	76	74	l
Turbulators	36	46	52	n°
Maximum condensation at 100% rated heat output (40-30°C)	2,1	2,5	3,9	l/h
Index of protection	X0D	X0D	X0D	IP
Power supply	230 V - 50 Hz	230 V - 50 Hz	230 V - 50 Hz	
Absorbed power supply (max)	300	300	300	W
Consumption at full load	Elmax	300	300	W
Consumption at part load	Elmin	90	90	W
Electrical consumption in standby mode	Psb	18	18	W

## CIRCULATION PUMP SIZING

The thermal units INSIEME EVO COND 45-55-70 LN are not equipped with circulator pump which must be installed on the system. For its dimensioning, consider pressure drops on water side of the thermal unit, shown in the diagram below.

### Water-side pressure drop

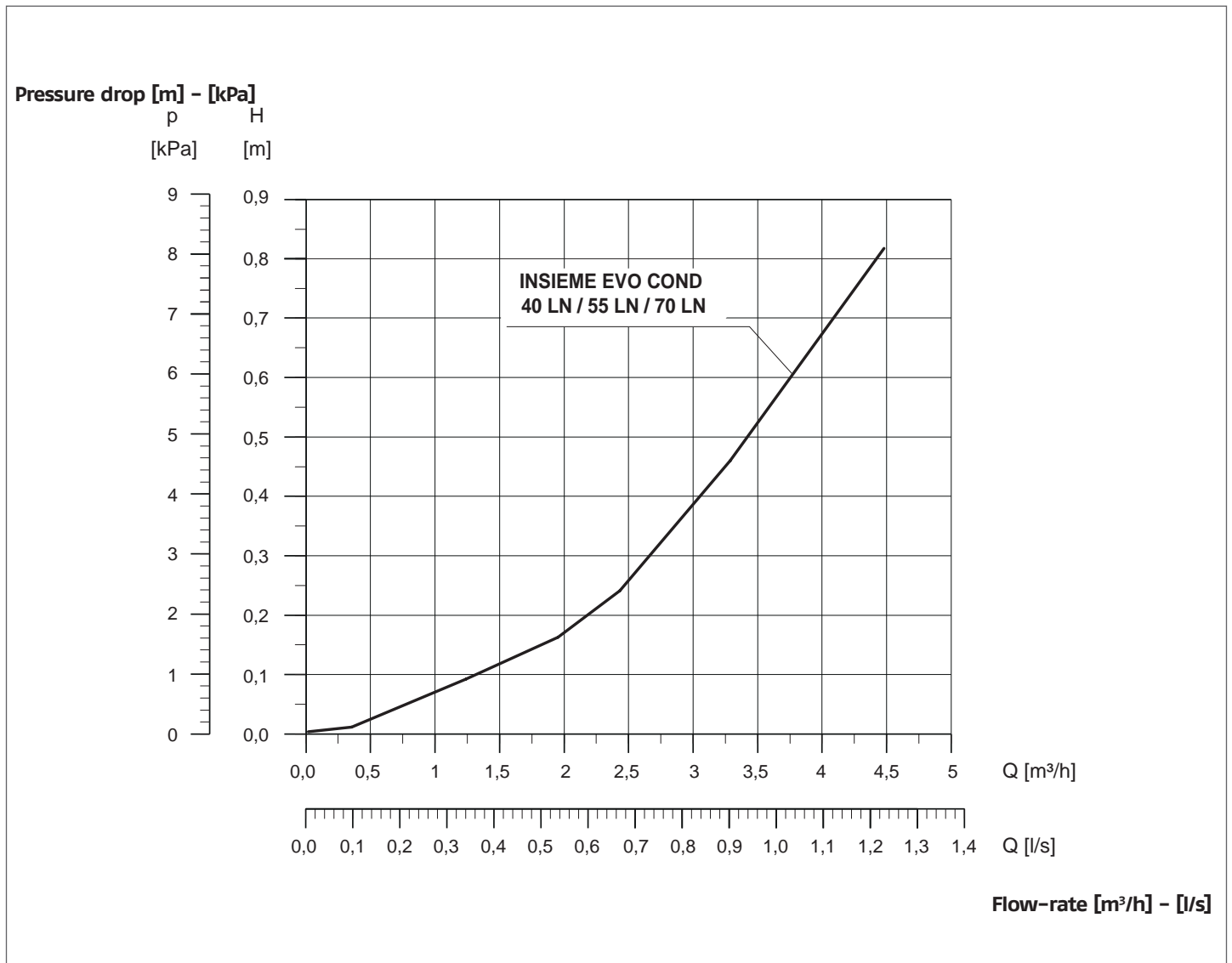

**⚠** When starting up for the first time and at least once a year, it is useful to check the rotation of the circulator pump shaft because, especially after long periods of inactivity, deposits and/or residues can prevent free rotation.

**⚠** Before loosening or removing the circulator cap, protect the electric devices located underneath from any water that exits.

**⊖** It is prohibited to operate the circulators without water.

1.8 Location of sensors

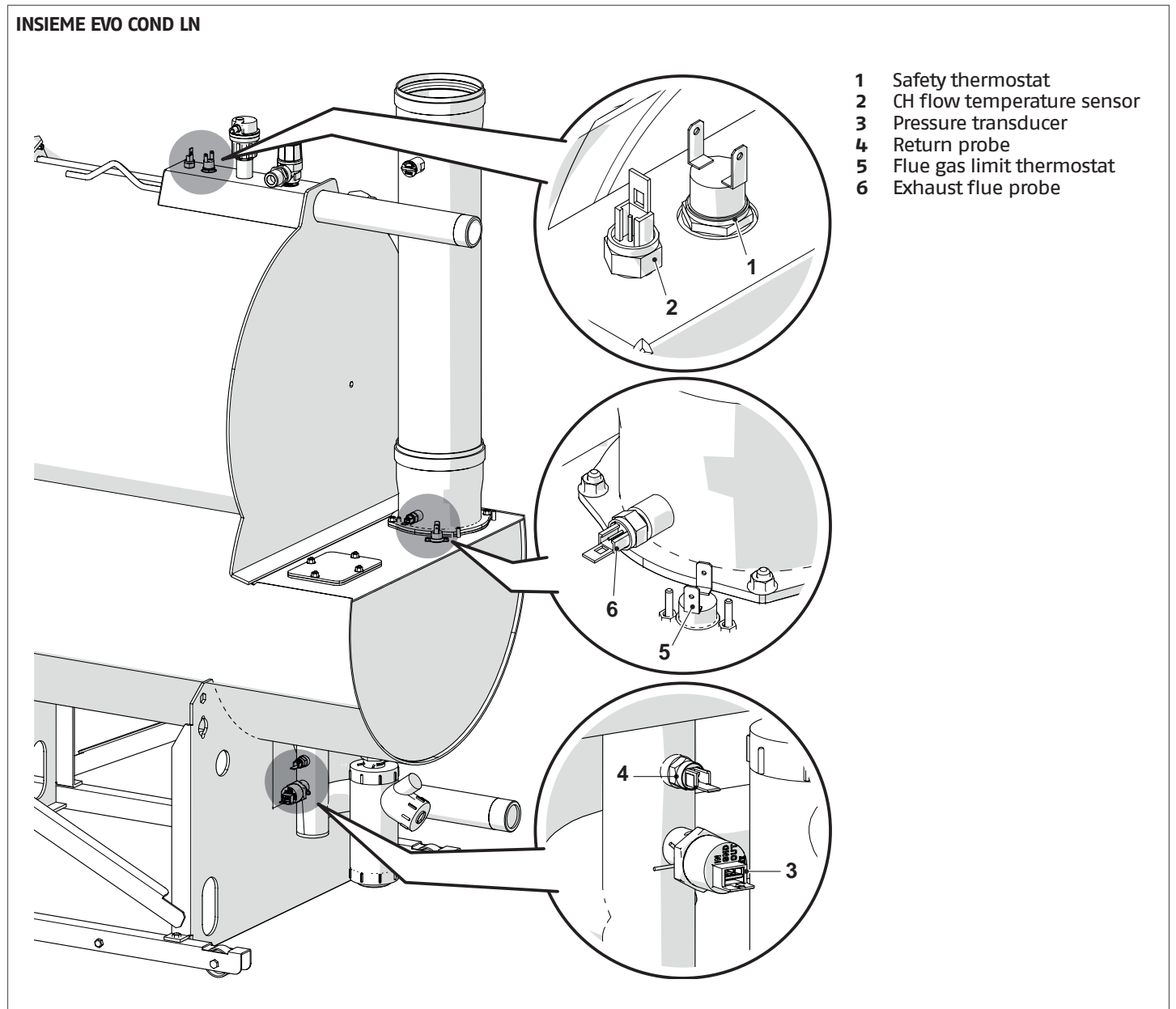

## 1.9 Control panel

### Controls interface

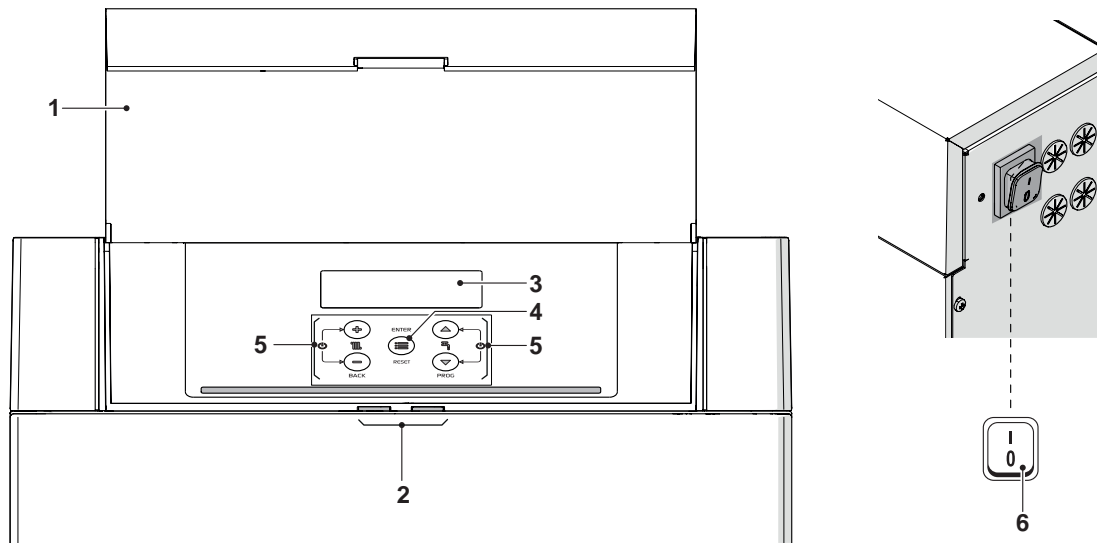

- 1 Door
- 2 Light guide
- 3 Rear light display
- 4 ENTER/RESET key: it allows accessing the main menu and restoring the operation after a stop due to an anomaly
- 5 Navigation keys
- 6 Main switch (located on the equipment rear wall)

### Light Guide displaying

STATUS	DESCRIZIONE
Green blinking	Thermal unit drain cycle and initialization in progress after the power supply reset.
Steady green	Thermal unit on
Steady red	Thermal unit in alarm mode
Red blinking	Thermal unit in lock-out mode

Display visualisation

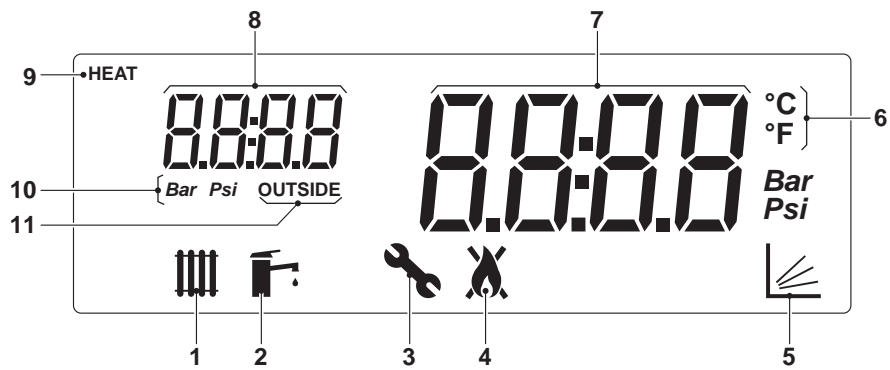

- 1 Icon displayed when heating mode is enabled. Blinking when there is a heat demand
- 2 Icon displayed when DHW mode is enabled. Blinking when there is an DHW Demand
- 3 Icon displayed when entering the "Installer" menu
- 4 Icon displayed when the burner of the equipment is on. The icon will be marked with a cross in case of Permanent or Temporary error.
- 5 Icon displayed when the climatic mode operation is active (Par. 2001= 1 or 2)
- 6 Celsius/Fahrenheit temperature
- 7 Displays current value
- 8 Displaying of system pressure or parameter number or external temperature
- 9 Icon displayed when the circulator is operating
- 10 Pressure in Bar/Psi
- 11 Icon displayed when the outdoor probe is connected

## 2 INSTALLATION

### 2.1 Unpacking the product

The thermal unit **INSIEME EVO COND LN** is supplied on pallet, protected by an anti-scratch canvas and triple wall cardboard package.

Check immediately that there is no damage and that the boiler is exactly as ordered. The product specifications are shown on the outside of the packing: model, power, equipment, fuel type. If there is any difference between the boiler ordered and that received, contact your agent, the warehouse or the sales department at head office immediately.

The following items are delivered in a plastic bag (1) inside the boiler:

- User manual
- Installation and maintenance manual
- Hydraulic test certificate
- Energy label
- Conventional warranty conditions

In an additional plastic bag (2) always positioned inside the thermal unit, two hoses for light oil (G 1/4" - G 3/8") and two G 3/8" fittings are supplied.

#### 2.1.1 Positioning of labels

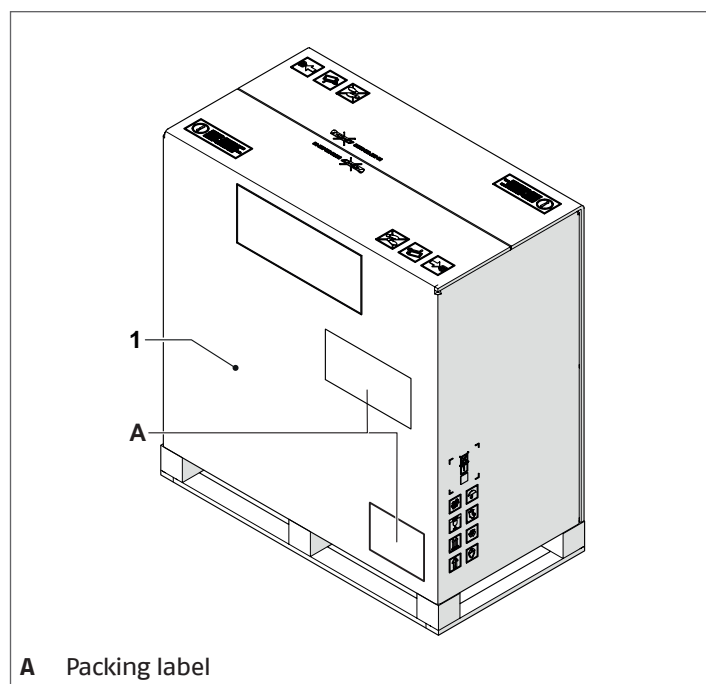

A Packing label

**⚠** The instruction manual is an integral part of the appliance; therefore, it should be read and stored carefully.

**⚠** Keep the documentation envelope in a safe place. Any replacement documents must be ordered from Riello S.p.A. who reserve the right to charge for the cost of the replacement.

### 2.2 Overall dimensions and weights

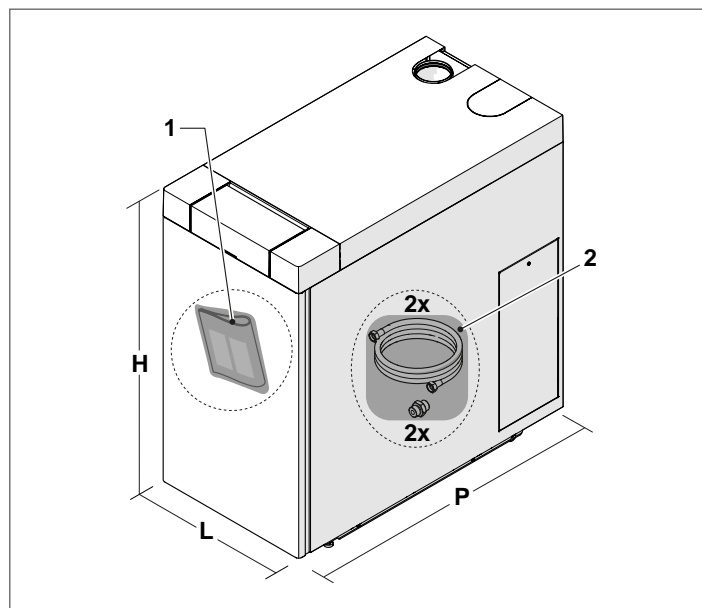

Description	INSIEME EVO COND			
	45 LN	55 LN	70 LN	
L	600			mm
P	1155			mm
H	1138			mm
Net weight	185	191	191	kg

### 2.3 Moving and removing the packing

**⚠** Wear suitable personal protection equipment when moving the boiler and removing the packing. Only use lifting equipment that is suitable for the weight involved.

Proceed as follows to remove the packing:

- remove the straps (A) fixing the packing to the pallet;

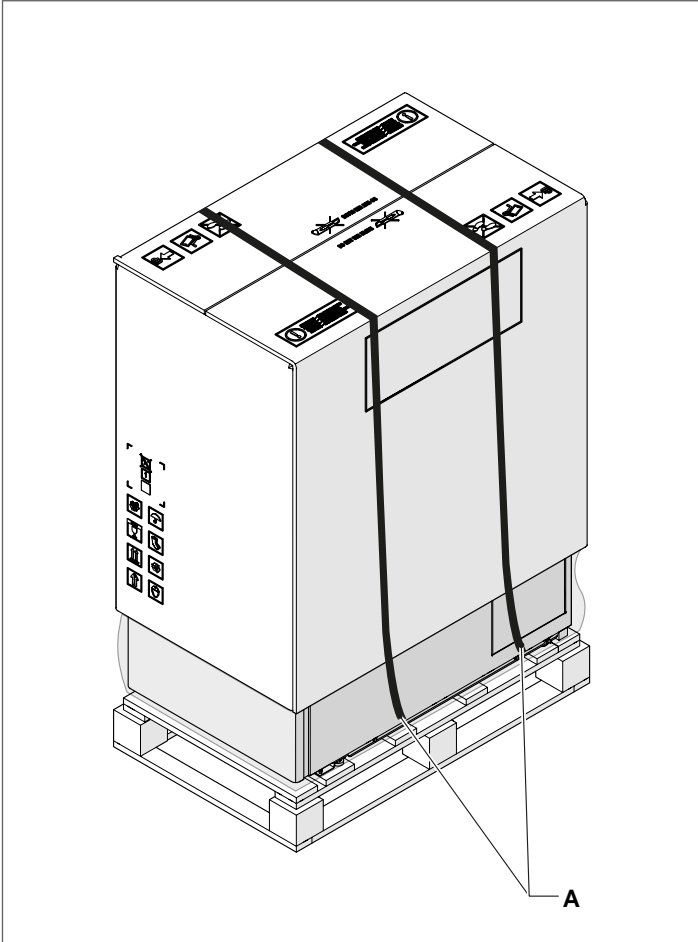

- remove the cardboard packing and non-scratch cloth.

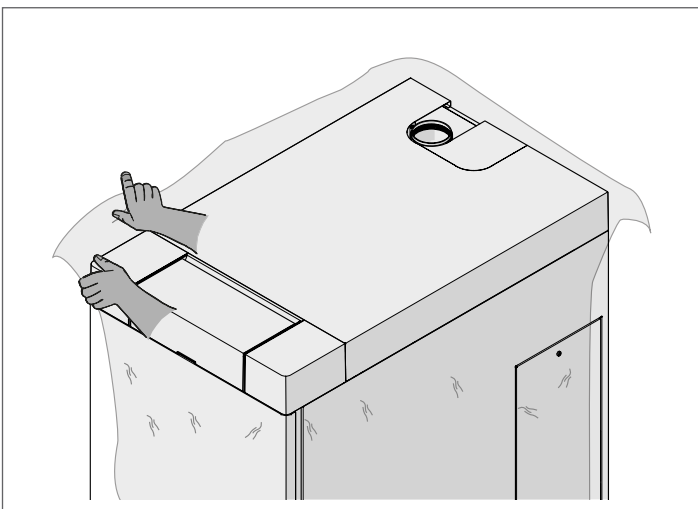

**⊖** Do not dispose of packaging material into the environment, or leave it within the reach of children, since it can become a potential hazard. Dispose of packaging material in compliance with applicable legislation.

Once the packaging has been removed, remove the fixing screw (2) and extract the front panel (1).

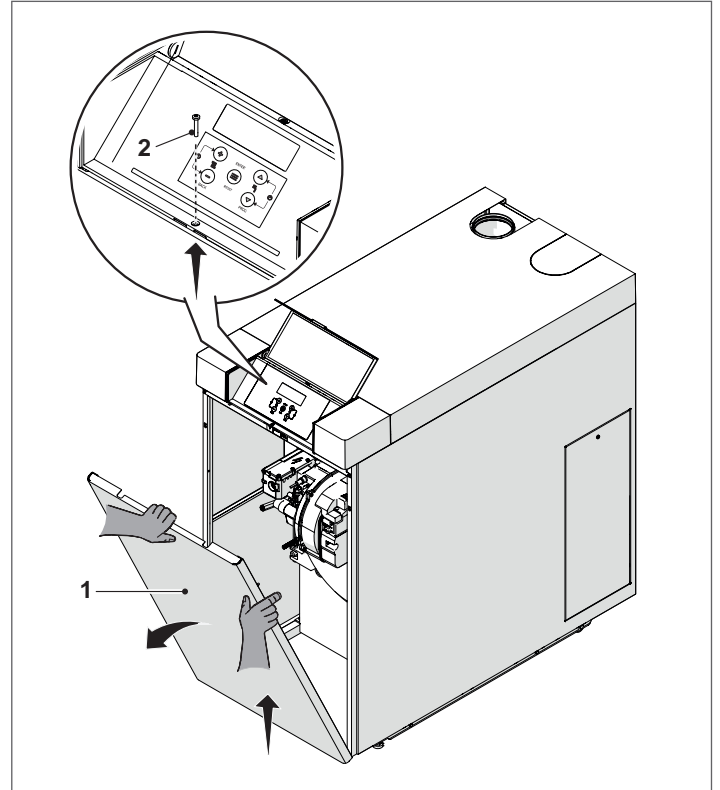

Locate the bag containing the documentation, extract the energy label and apply it to the boiler casing.

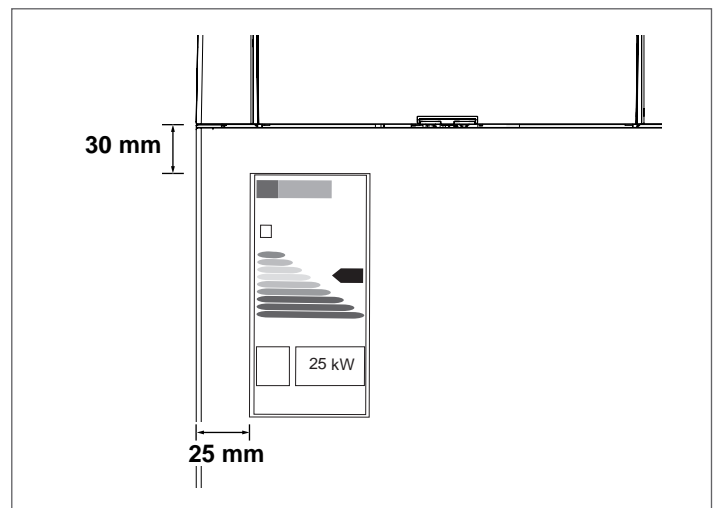

#### HANDLING WITH SUPPORT RAILS

- Loosen the screws (3) fastening the pallet (4)

- Insert two pieces of tube (5) with suitable length in the relevant holes, letting them come out evenly from both sides. Use the protruding lengths of pipe as lifting handles.

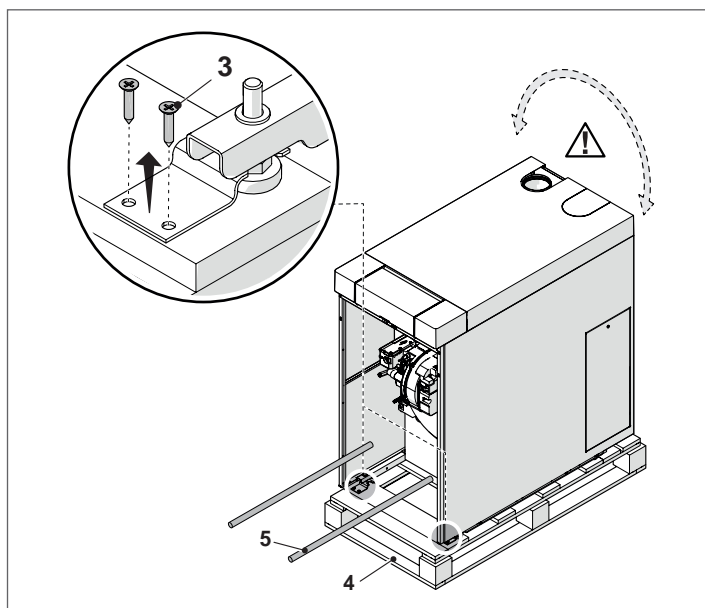

- ⚠** Take care because the boiler might swing when lifted. With flat and smooth flooring and for **small** movements, the thermal unit can be **slightly** lifted and moved through the wheels (6).

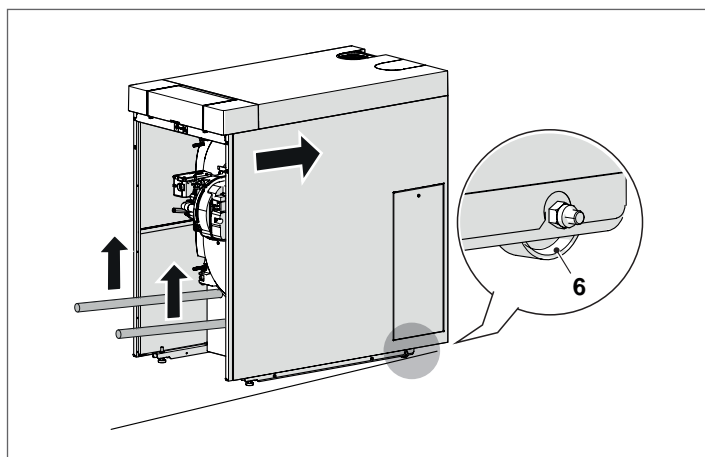

Level the thermal unit by acting on the 2 feet on the front side of the thermal unit.

## 2.4 Installation premises

The thermal unit **INSIEME EVO COND LN** must be installed in rooms with appropriately sized vent openings which comply with the Technical Standards and Regulations in force in the place of installation.

- ⚠** When installing the boiler, allow sufficient space around it to access all safety and control devices and to permit easy maintenance.
- ⚠** Check that the electric protection level of the appliance is suitable for features of the room where it is installed.

- ⚠** Make sure that comburent air is not contaminated by substances containing chlorine or fluorine (elements found in sprays, paints, detergents etc.).

- ⊖** These boilers must be installed indoors. They are not designed for outside use.

- ⊖** Do not obstruct or restrict the air vents in the room where the boiler is installed. A free air supply is essential for correct combustion.

### 2.4.1 Recommended minimum distances

This figure shows the minimum installation distances that must be respected in order to allow proper maintenance of the boiler.

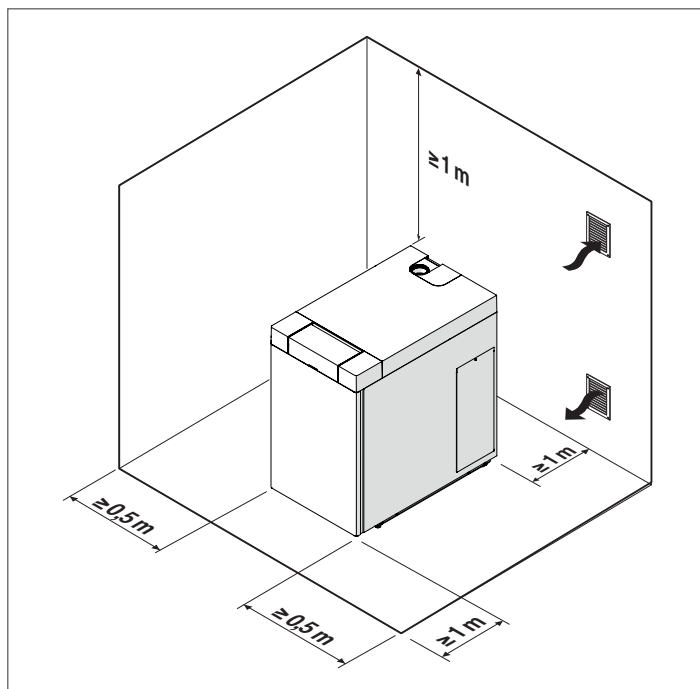

## 2.5 Installation in older systems and systems requiring modernisation

When installing these boilers in older systems or systems requiring modernisation, always perform the following checks:

- Make sure that the flue is able to withstand the temperature of the combustion gases and that it has been designed and made in compliance with applicable standards. The flue must also be as straight as possible, sealed, insulated and not blocked or choked
- Make sure that the electrical supply system has been installed by a qualified electrician in compliance with applicable standards
- Make sure that the fuel feed line and any storage tank are made and installed in compliance with applicable standards
- Make sure that expansion vessels are big enough to contain the additional volume generated by thermal expansion
- Make sure that the flow rate, head and direction of flow of the pumps are suitable and correct
- Make sure that the central heating circuit has been flushed out to remove all sludge and lime scale, and that it has been bled and seal tested
- Make sure that a suitable water treatment system is installed if the quality of the supply/recirculation water so demands. (Refer to the reference values on page 32); See **RIELLO's** Catalogue

- ⚠** The manufacturer declines all responsibility for damage caused by incorrectly constructed flue systems.

## 2.6 Water connections

The dimensions and positioning of the hydraulic connections of the thermal unit **INSIEME EVO COND LN** are shown in the table. Before installing the boiler, flush out all the pipes of the central heating circuit to remove any machining residues.

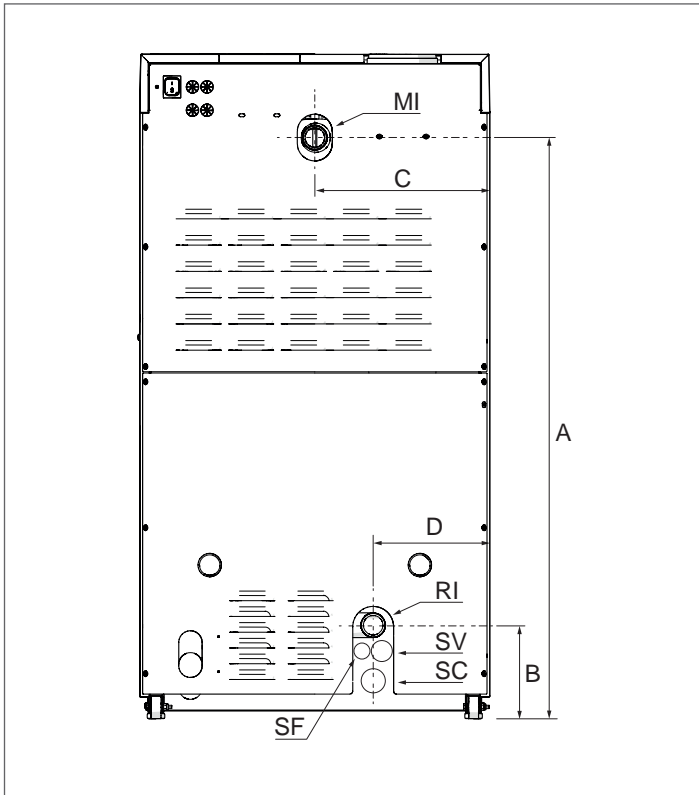

DESCRIZIONE	INSIEME EVO COND			UM
	45 LN	55 LN	70 LN	
A		995		mm
B		160		mm
C		300		mm
D		200		mm
MI (system delivery line)		1"1/4 M		∅
RI (system return line)		1"1/4 M		∅
Sf (automatic drain valve drain)		11		∅ mm
SV (safety valve drain)		21		∅ mm
SC (condensate drain)		21		∅ mm

## 2.7 Boiler water circuit

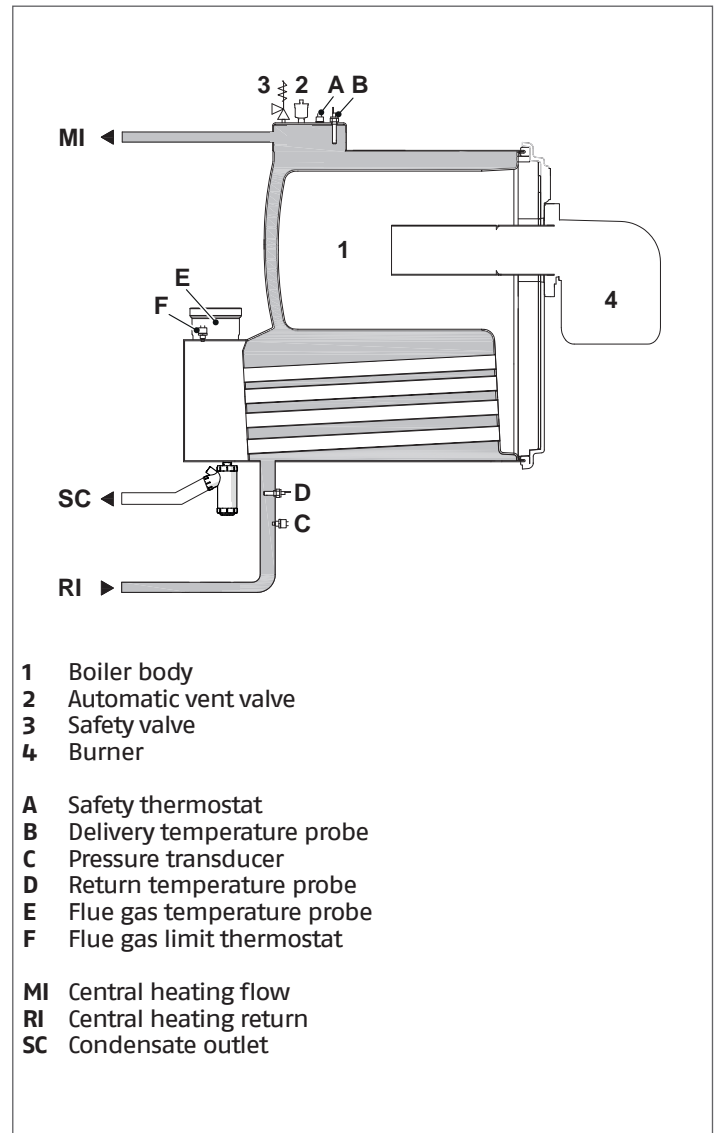

- 1 Boiler body
- 2 Automatic vent valve
- 3 Safety valve
- 4 Burner
  
- A Safety thermostat
- B Delivery temperature probe
- C Pressure transducer
- D Return temperature probe
- E Flue gas temperature probe
- F Flue gas limit thermostat
  
- MI Central heating flow
- RI Central heating return
- SC Condensate outlet

## 2.8 Source water systems and configurations

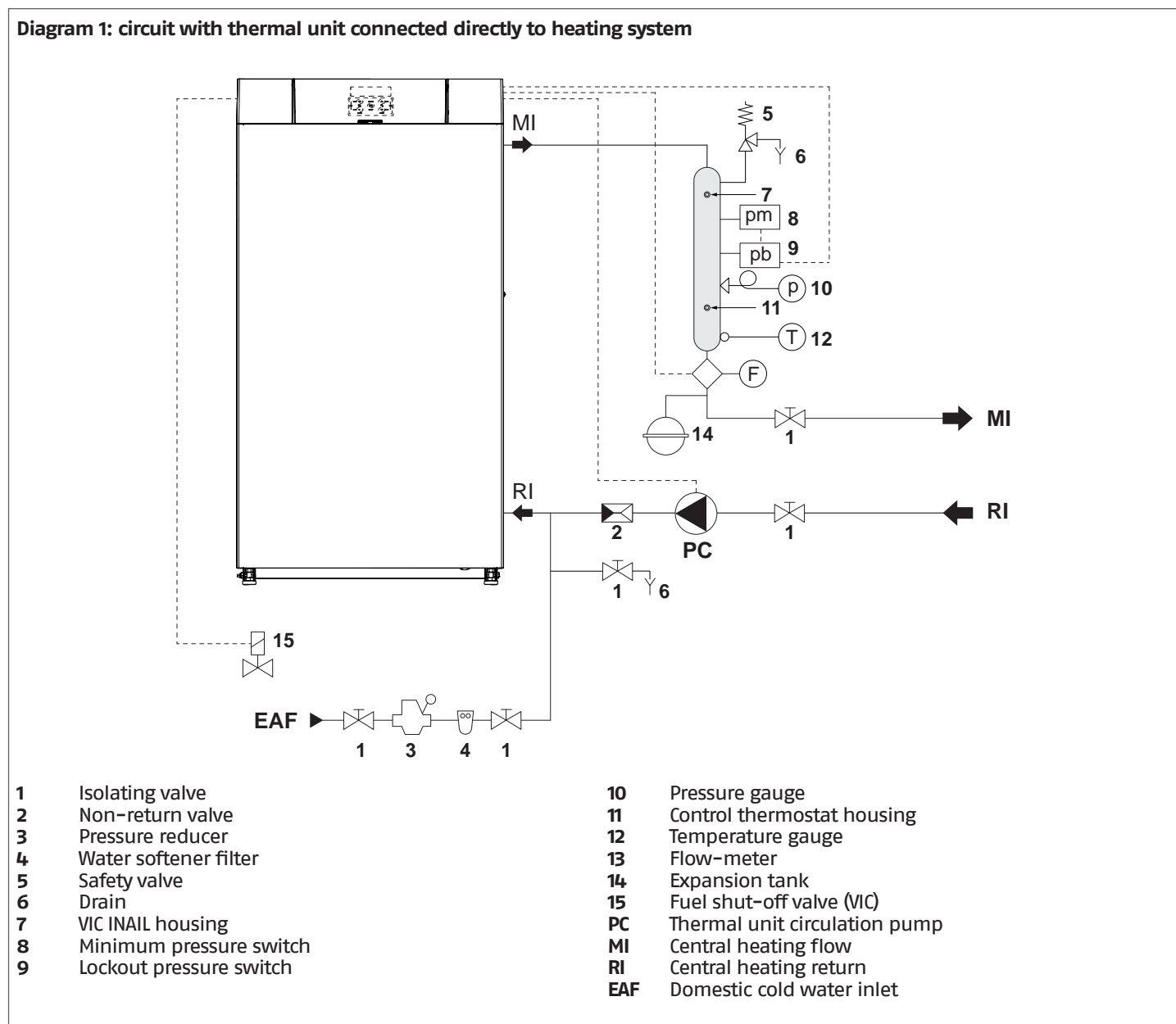

- ⚠** The selection and the installation of the components of the system is the responsibility of the installer, who must operate in accordance with good practice and current Legislation.
- ⚠** If needed, water supplies and recovery circuits must be conditioned by suitable treatment systems. Refer to the values listed in the table on page 32.
- ⚠** The thermal unit can be connected to an ATRB 120 puffer tank using special accessory kits (see Catalogue).
- ⚠** Domestic hot water and central heating circuits must be completed with expansion vessels of adequate capacity and suitable, correctly-sized safety valves. The discharge of safety valves and appliances must be connected to a suitable collection and disposal system (see Catalogue for compatible accessories).
- ⊘** It is prohibited to operate the circulators without water.

Electrical connections – Diagram 1

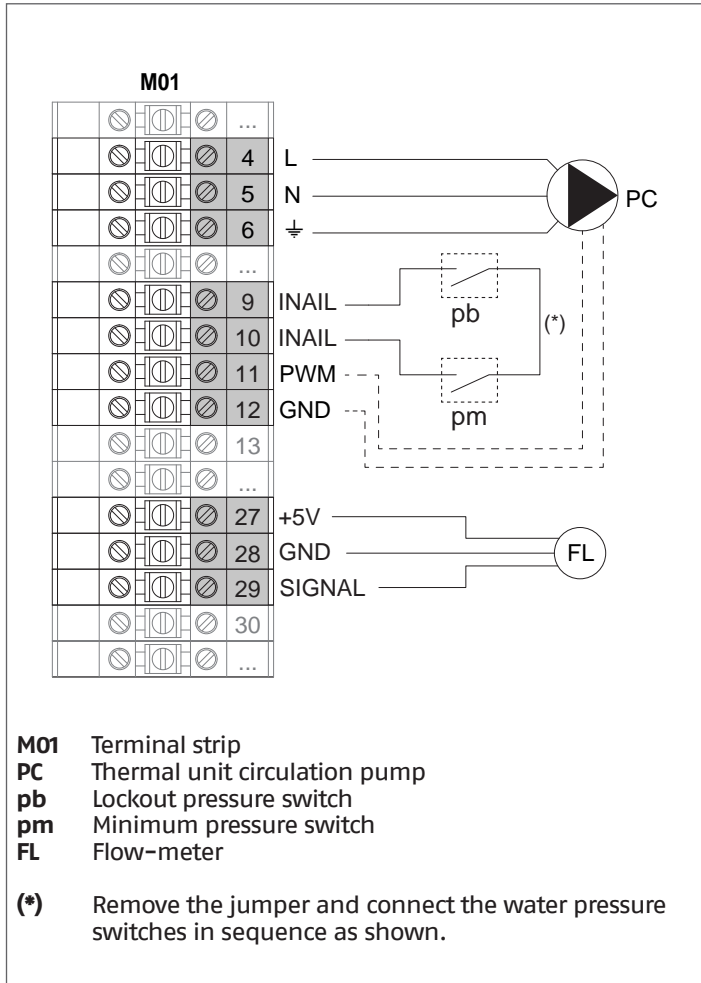

Basic parameters configuration Diagram 1

Par. No.	Description	Parameter setting	
2027	Progr.ble Inp. 2	1 = Heating flow meter (*)	FL
2029	Progr.ble Inp. 8	1= Heating pressure switch (**)	INAIL
2030	Progr.ble Out. 1	1 = VIC relay output on (**)	VIC
2033	Progr.ble Out. 4	1= Thermal unit pump (**)	PC

(\*) For further information see paragraph "Flow meter parameters configuration (accessory)"

(\*\*) Default setting

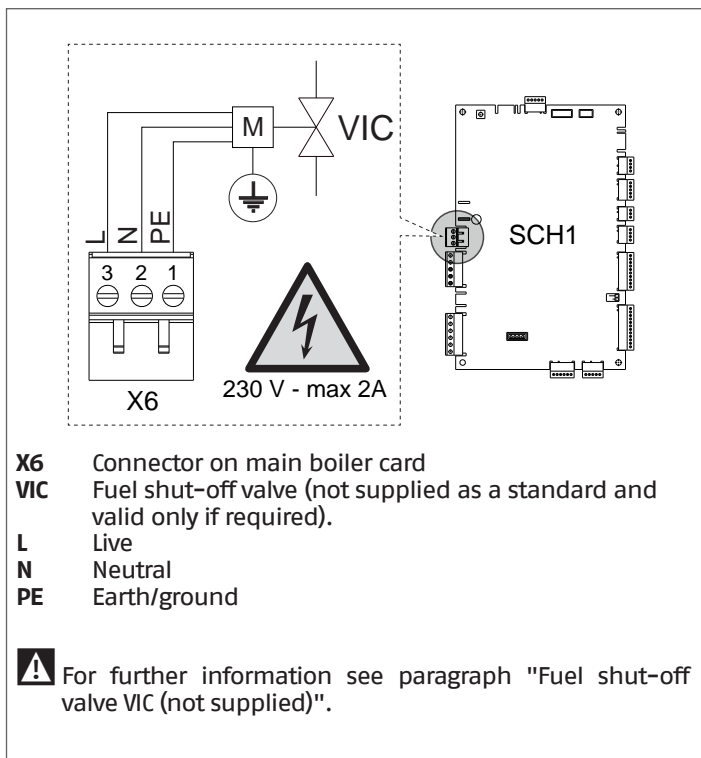

**Diagram 2: circuit with thermal unit connected directly to central heating and DHW production system with storage tank and external diverter valve**

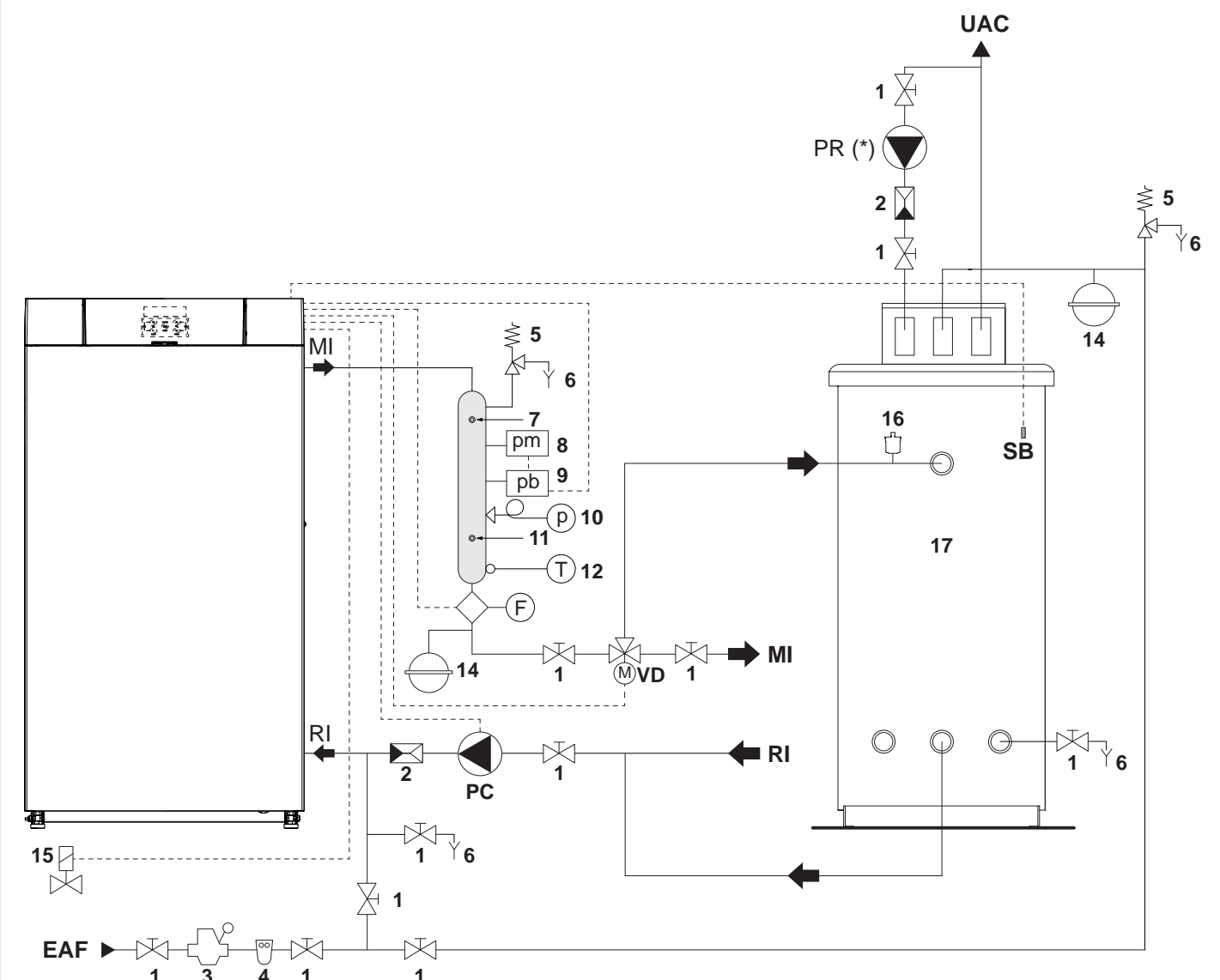

- |    |                            |      |  |
|----|----------------------------|------|--|
| 1  | Isolating valve            | 15   | Fuel shut-off valve (VIC)                                    |
| 2  | Non-return valve           | 16   | Automatic bleed valve  |
| 3  | Pressure reducer           | 17   | Storage cylinder   |
| 4  | Water softener filter      | MI   | Central heating flow   |
| 5  | Safety valve               | RI   | Central heating return                                       |
| 6  | Drain                      | EAFF | Domestic cold water inlet                                    |
| 7  | VIC INAIL housing          | UAC  | Domestic hot water outlet                                    |
| 8  | Minimum pressure switch    | PC   | Thermal unit circulation pump                                |
| 9  | Lockout pressure switch    | VD   | DHW diverting valve  |
| 10 | Pressure gauge             | SB   | Heater probe/thermostat                                      |
| 11 | Control thermostat housing | PR   | DHW circulation pump   |
| 12 | Temperature gauge          | (*)  | Circulator pump not controlled by the thermal unit regulator |
| 13 | Flow-meter                 |      |  |
| 14 | Expansion tank             |      |  |

**⚠** The selection and the installation of the components of the system is the responsibility of the installer, who must operate in accordance with good practice and current Legislation.

**⚠** If needed, water supplies and recovery circuits must be conditioned by suitable treatment systems. Refer to the values listed in the table on page 32.

**⚠** The thermal unit can be connected to an ATRB 120 puffer tank using special accessory kits (see Catalogue).

**⚠** Domestic hot water and central heating circuits must be completed with expansion vessels of adequate capacity and suitable, correctly-sized safety valves. The discharge of safety valves and appliances must be connected to a suitable collection and disposal system (see Catalogue for compatible accessories).

**⊖** It is prohibited to operate the circulators without water.

Electrical connections - Diagram 2

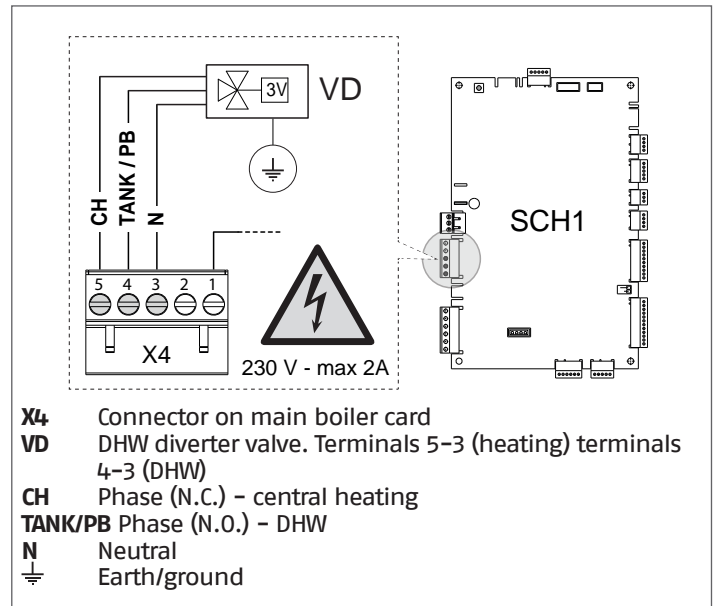
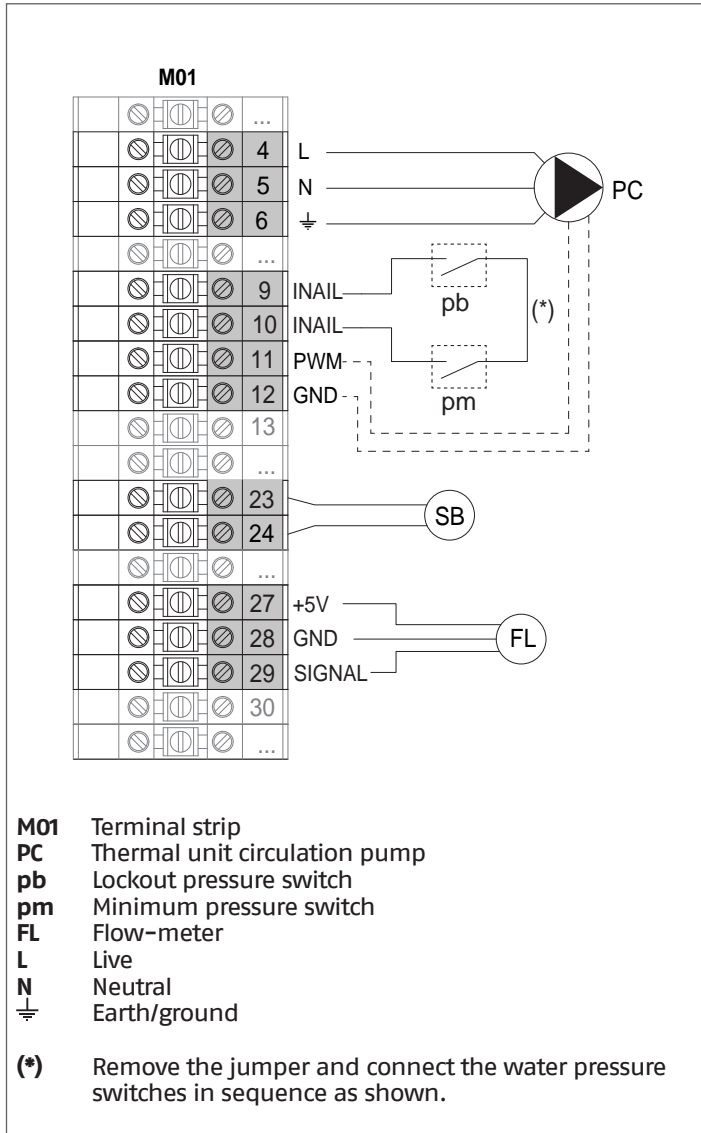

Basic parameters configuration Diagram 2

Par. No.	Description	Parameter setting	
2027	Progr.ble Inp. 2	1 = Heating flow meter (*)	FL
2029	Progr.ble Inp. 8	1= Heating pressure switch (**)	INAIL
2030	Progr.ble Out. 1	1 = VIC relay output on (**)	VIC
2032	Prog. Out. 2	1= 3-way valve with DHW storage tank before the separator	VD
2033	Progr.ble Out. 4	1= Thermal unit pump (**)	PC
2035	Hot water mode	1 = DHW with heater	
2080	Anti-le-gionella	1 = daily 2 = weekly	(***)

**(\*)** For further information see paragraph "Flow meter parameters configuration (accessory)".

**(\*\*)** Default setting

**(\*\*\*)** Choose according to requirements

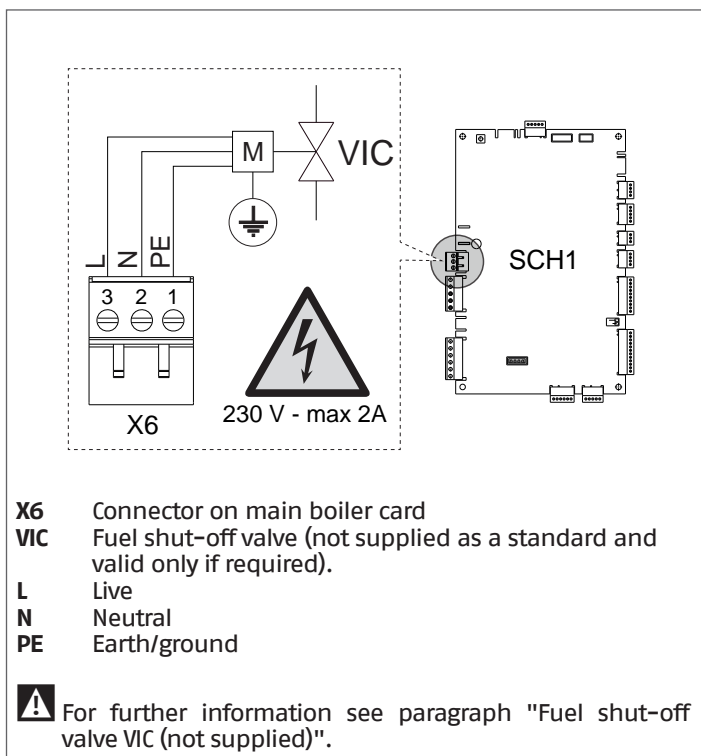

**Diagram 3: circuit with thermal unit connected directly to central heating and DHW production system with storage tank and dedicated pump**

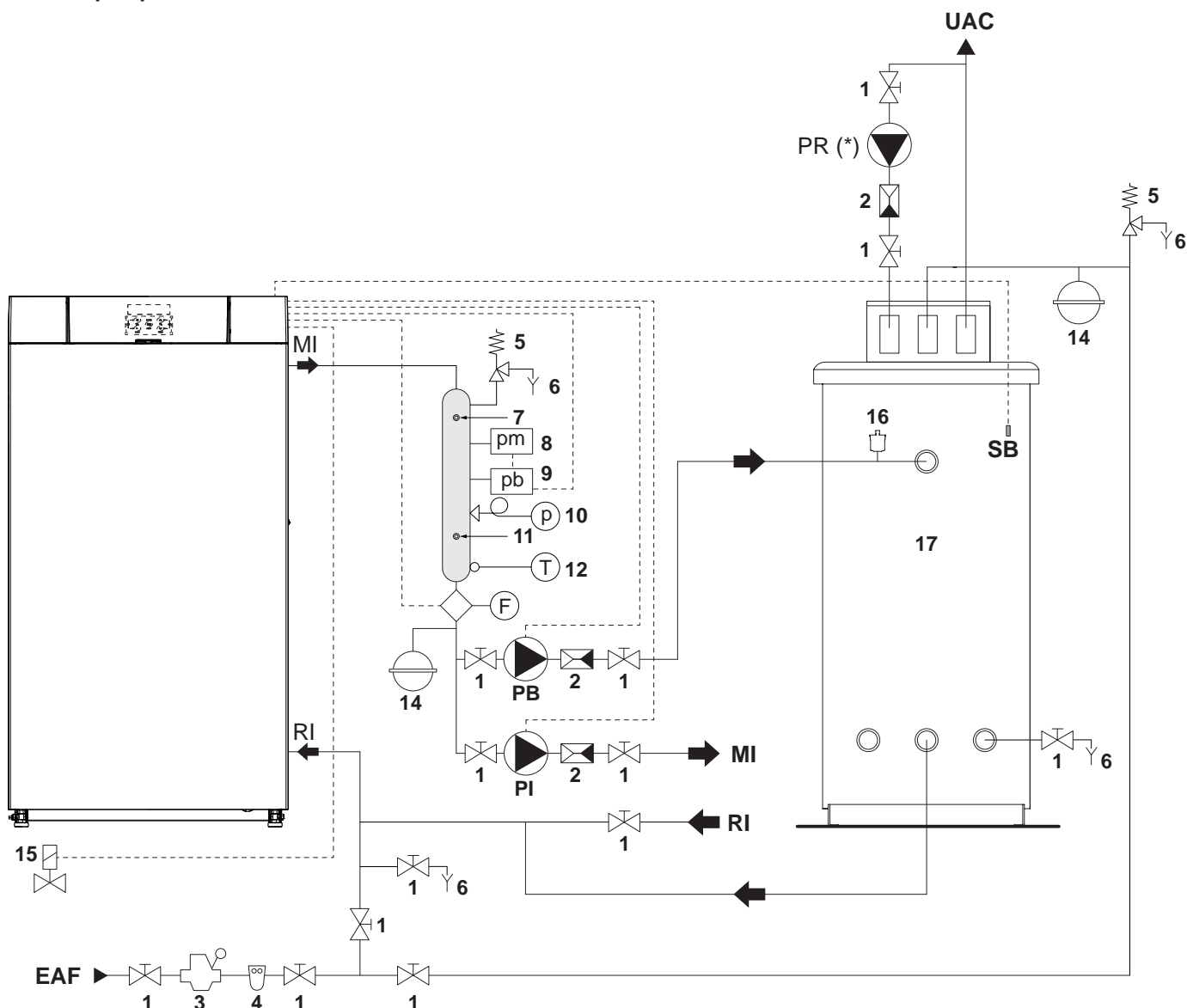

- |    |                            |     |  |
|----|----------------------------|-----|--|
| 1  | Isolating valve            | 14  | Expansion tank   |
| 2  | Non-return valve           | 15  | Fuel shut-off valve (VIC)                                    |
| 3  | Pressure reducer           | 16  | Automatic bleed valve  |
| 4  | Water softener filter      | 17  | Storage cylinder   |
| 5  | Safety valve               | MI  | Central heating flow   |
| 6  | Drain                      | RI  | Central heating return                                       |
| 7  | VIC INAIL housing          | EAF | Domestic cold water inlet                                    |
| 8  | Minimum pressure switch    | UAC | Domestic hot water outlet                                    |
| 9  | Lockout pressure switch    | PI  | Central heating system pump                                  |
| 10 | Pressure gauge             | PB  | DHW circulator   |
| 11 | Control thermostat housing | SB  | Heater probe/thermostat                                      |
| 12 | Temperature gauge          | PR  | DHW circulation pump   |
| 13 | Flow-meter                 | (*) | Circulator pump not controlled by the thermal unit regulator |

- The safety valves must be connected to a suitable collection and drain system.
- The selection and the installation of the components of the system is the responsibility of the installer, who must operate in accordance with good practice and current legislation.
- If needed, water supplies and recovery circuits must be conditioned by suitable treatment systems. Refer to the values listed in the table on page 32.
- The thermal unit can be connected to an ATRB 120 puffer tank using special accessory kits (see Catalogue).
- Domestic hot water and central heating circuits must be completed with expansion vessels of adequate capacity and suitable, correctly-sized safety valves. The discharge of safety valves and appliances must be connected to a suitable collection and disposal system (see Catalogue for compatible accessories).
- It is prohibited to operate the circulators without water.

Electrical connections - Diagram 3

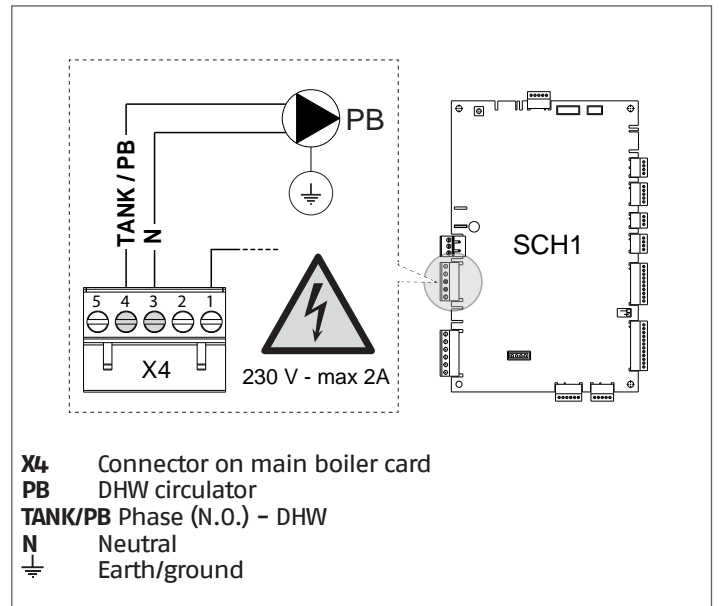
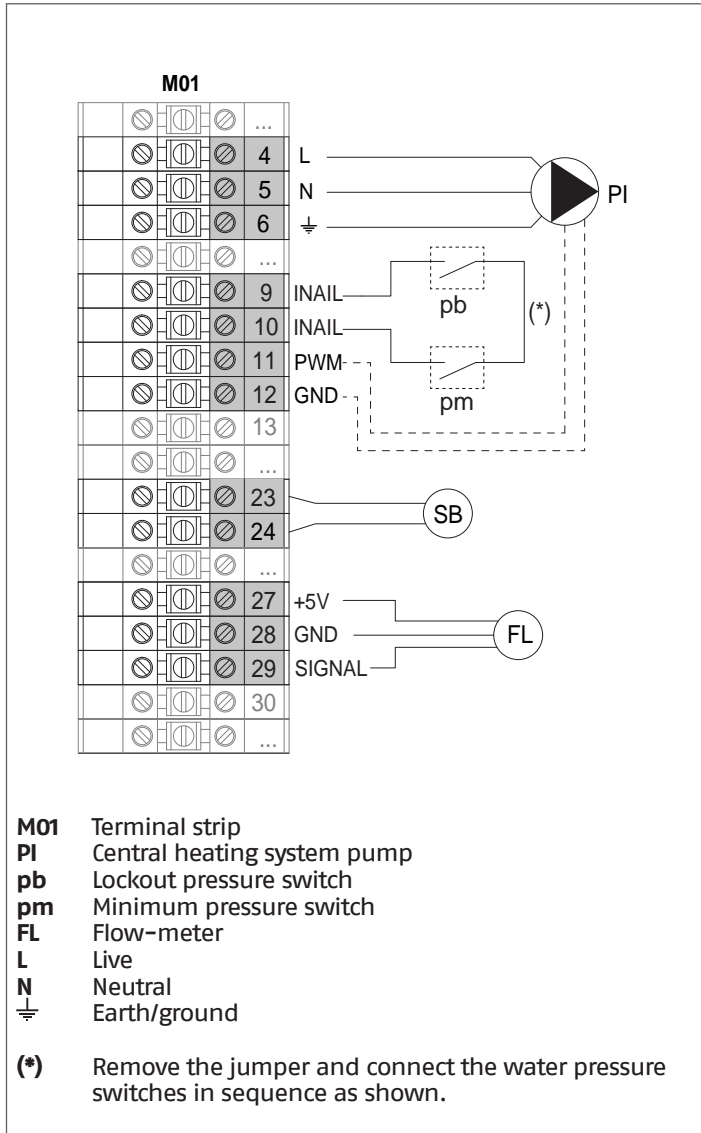

Basic parameters configuration Diagram 3

Par. No.	Description	Parameter setting	
2027	Progr.ble Inp. 2	1 = Heating flow meter (*)	FL
2029	Progr.ble Inp. 8	1= Heating pressure switch (**)	INAIL
2030	Progr.ble Out. 1	1 = VIC relay output on (**)	VIC
2032	Prog. Out. 2	3 = DHW storage tank pump	PB
2033	Progr.ble Out. 4	2= System pump	PI
2035	Hot water mode	1 = DHW with heater	
2080	Anti-legionella	1 = daily 2 = weekly	(***)

- (\*)** For further information see paragraph "Flow meter parameters configuration (accessory)".
- (\*\*)** Default setting
- (\*\*\*)** Choose according to requirements

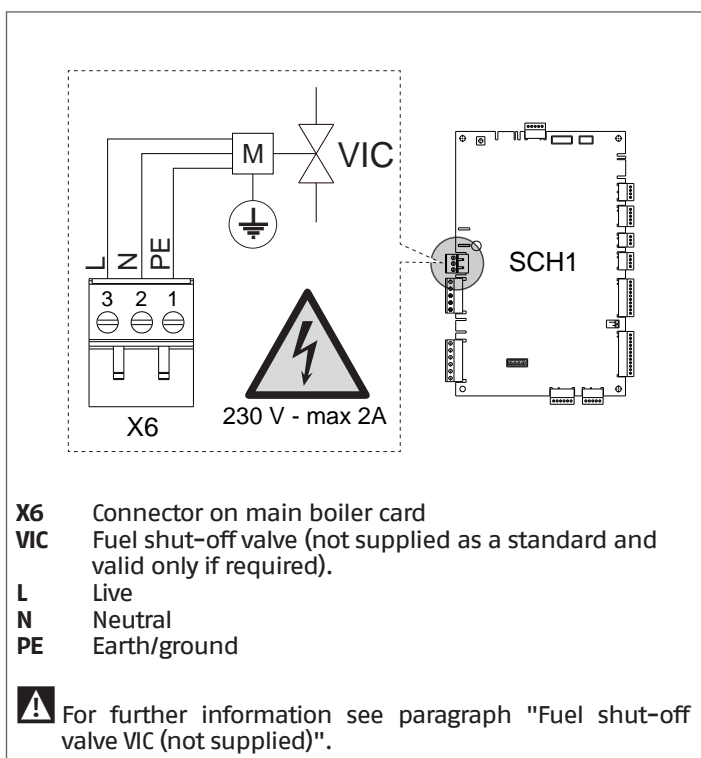

## 2.9 Fuel connections

The thermal unit **INSIEME EVO COND LN** is supplied with two hoses for supplying light oil to the burner that must be connected by the installer.

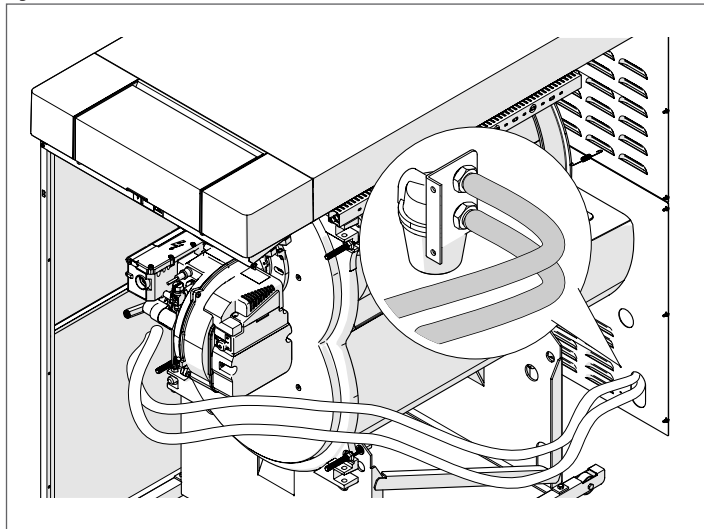

The connection to the light oil pump suction must be made directly on the filter (1) (accessory); the return pipe must be connected to the preset union (2).

Make sure that these connections are oil tight.

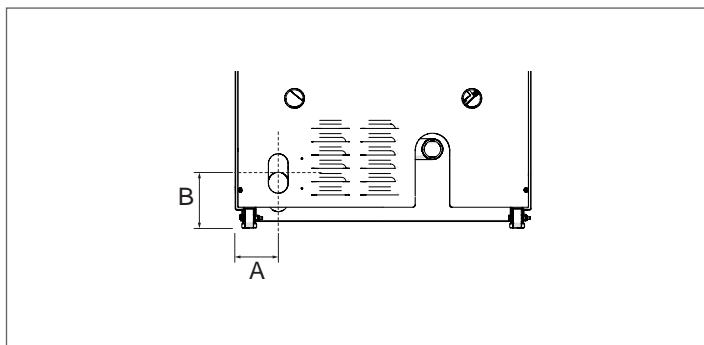
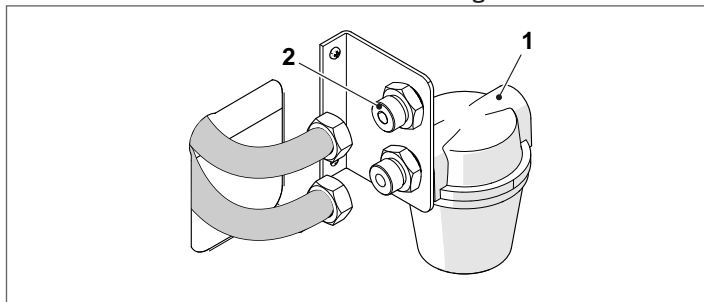

Description	INSIEME EVO COND			∅
	45 LN	55 LN	70 LN	
Fittings	2x3/8" M			
A	87			mm
B	113			mm

If the oil feed system is in negative pressure, the return line must reach the same height as the suction line. This avoids having to install a bottom valve, which would be essential if the return hose were to be located above the level of the fuel.

- ⚠ The installer must ensure that the negative pressure differential in the oil feed never exceeds 0.4 bar (30 cm Hg). If this value is exceeded, the fuel oil will release gas. Make sure that the oil hoses are perfectly oil-tight.
- ⚠ Clean out the oil tank at suitable intervals.
- ⚠ The fuel supply system must be suitable for the burner capacity and must be equipped with all the safety and control devices required by the Standards in force. For its size, refer to the table on page "26 27" of paragraph "Priming the pump".
- ⚠ A filter must be installed in the oil feed line.
- ⚠ Before starting the thermal unit, make sure that the return pipe line is not clogged. An excessive back pressure would cause the breakage of the circulator seal.
- ⚠ On completion of the installation, check that all joints are sealed.

### Light oil pump

- ⚠ Before starting the burner, make sure that the tank return line is not clogged. Obstructions in the line could cause the sealing organ located on the pump shaft to break.

The pump is designed to allow working with two pipes. For single pipe operation undo the return plug (2), remove the by-pass screw (3) and then tighten the plug (2) again.

- ⚠ The suction plug (1) is made of plastic. Once removed, it must not be used again. In single-pipe installations the return plug (2) must be absolutely made of steel.

### Model INSIEME EVO COND 45 LN

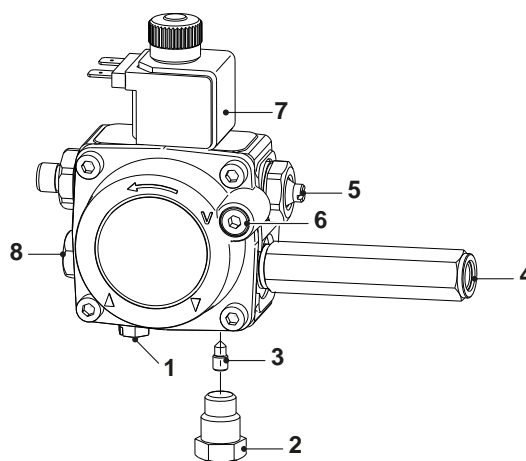

- 1 Suction port
- 2 Return
- 3 By-pass screw
- 4 Pressure gauge fitting
- 5 Pressure adjuster screw
- 6 Vacuum gauge fitting
- 7 Solenoid valve
- 8 Auxiliary pressure measurement fitting

**Model INSIEME EVO COND 55 LN and 70 LN**

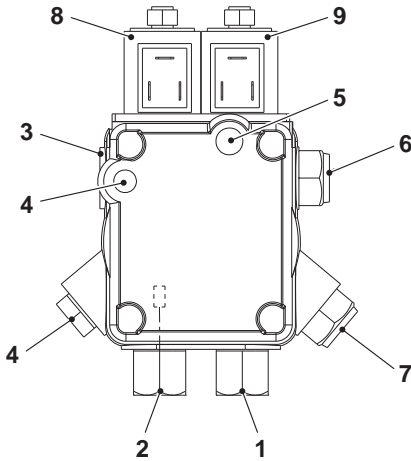

- 1 Suction port
- 2 Return
- 3 Outlet at the nozzle
- 4 Pressure gauge fitting
- 5 Vacuum gauge fitting
- 6 1st stage pressure adjustment
- 7 2nd stage pressure adjustment
- 8 1st stage valve
- 9 2nd stage valve

**2.9.1 Dual-pipe system**

Dual-pipe vacuum systems have a negative fuel pressure (depression) at the burner inlet. They typically have the tank at a lower height than the burner. The return line should terminate in the light oil tank at the same level as the suction line; in this case a non-return valve is not necessary. Should however the return line arrives over the fuel level, the non-return valve is indispensable.

**⚠** You are advised to use additional filters on the fuel supply line. The Manufacturer recommends the use of a good quality fuel filter on the tank and a secondary filter (supplied as an accessory) to protect the pump and the nozzle from contamination.

**Priming the pump**

**⚠** Before igniting the burner, make sure that the return pipe is not obstructed; any obstruction will cause the pump's sealing devices to break.

To prime the oil pump simply start up the burner and check for a flame.

If the burner enters lockout before any fuel reaches it, wait at least 20 seconds then turn the function selector to position (II) "Reset burner" for at least 1 second before returning it to position (I). Wait for the burner to complete the entire ignition cycle again, up to the ignition of the flame.

**⚠** The installer must ensure that the negative pressure differential in the oil feed never exceeds 0.4 bar (30 cm Hg). If this value is exceeded, the fuel oil will release gas. Make sure that the oil hoses are perfectly oil-tight.

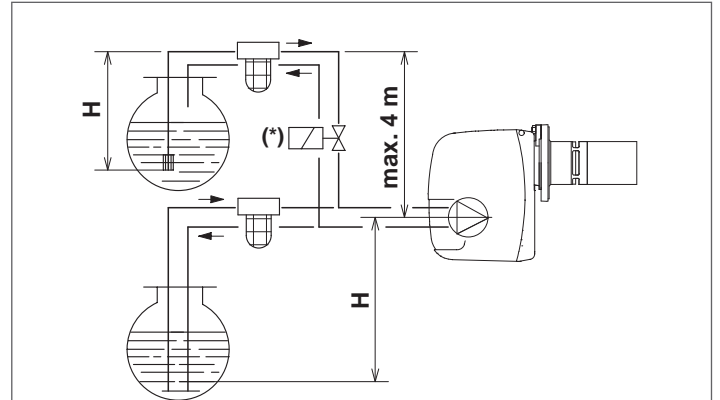

(\*) VIC: Fuel shut-off valve (where provided)

For the electrical connection, please refer to section "Fuel shut-off valve VIC (not supplied)".

**⚠** Where a fuel shut-off valve (VIC) is to be installed on the diesel gas supply circuit to the burner, closure of the valve must be delayed to prevent the section of hose between the pump and the valve going into negative pressure (empty).

In parameter 2079 it is possible to set the delay time (seconds) of the closing of the VIC valve with respect to the burner. The value to be set must always be  $\geq$  than the post-ventilation time of the burner.

H (m)	L (m)	
	Øi (8mm)	Øi (10mm)
0	35	100
0,5	30	100
1	25	100
1,5	20	90
2	15	70
3	8	30
3,5	6	20

- H = Height difference
- L = Maximum length of suction hose
- Øi = Internal diameter of hose

The table shows the approximate maximum lengths for the supply line, depending on the height difference, length and diameter of the fuel line.

## 2.9.2 Single-pipe system

Pressurised single-pipe systems have a positive fuel pressure at the burner inlet.

Usually the tank is higher than the burner, or the fuel pumping systems are on the outside of the boiler.

Single-pipe vacuum systems have a negative fuel pressure (depression) at the burner inlet.

Usually the tank is lower than the burner.

**⚠** You are advised to use additional filters on the fuel supply line. The Manufacturer recommends the use of a good quality fuel filter on the tank and a secondary filter (supplied as an accessory) to protect the pump and the nozzle from contamination.

### Priming the pump

On single-pipe pressurised systems, simply loosen the vacuum-eter cap and wait until the fuel comes out.

On single-pipe vacuum systems, switch on the burner and wait for ignition.

To prime the oil pump simply start up the burner and check for a flame.

If the burner enters lockout before any fuel reaches it, wait at least 20 seconds then turn the function selector to position (II) "Reset burner" for at least 1 second before returning it to position (I). Wait for the burner to complete the entire ignition cycle again, up to the ignition of the flame.

**⚠** The installer must ensure that the supply pressure does not exceed 0.5 bar. Above this level, the pump seal is too stressed.

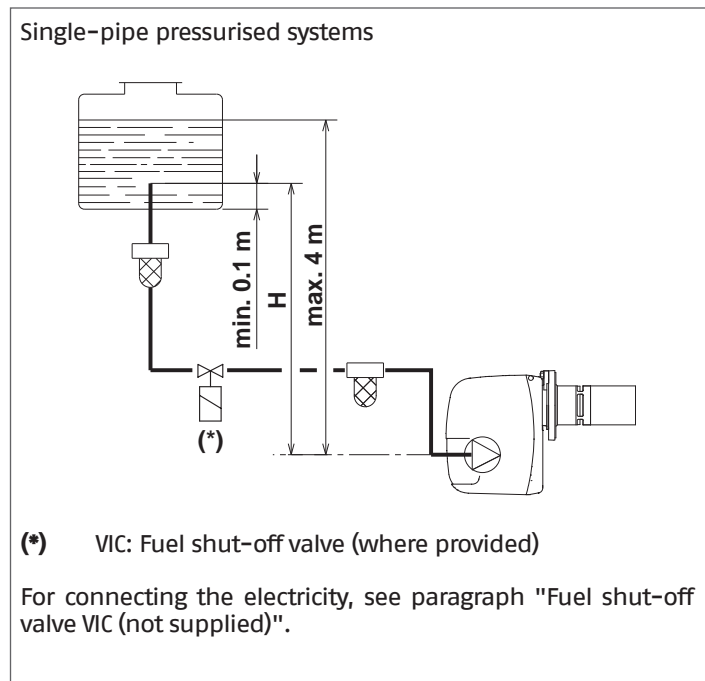

**⚠** Where a fuel shut-off valve (VIC) is to be installed on the diesel gas supply circuit to the burner, closure of the valve must be delayed to prevent the section of hose between the pump and the valve going into negative pressure (empty). In parameter 2079 you can set the time delay (seconds) on the closure of the VIC valve with respect to the burner. The value to be set must always be  $\geq$  the burner's post-ventilation time.

H (m)	L (m)	
	Øi (8mm)	Øi (10mm)
0,5	10	20
1	20	40
1,5	40	80
2	60	100

**H** = Height difference

**L** = Maximum length of suction hose

**Øi** = Internal diameter of hose

### Single-pipe vacuum systems

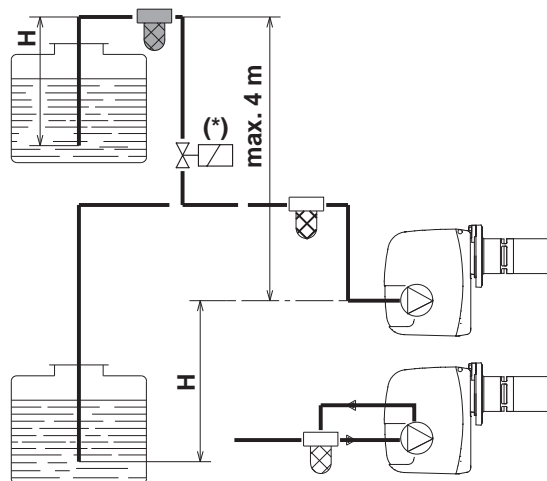

**(\*)** VIC: Fuel shut-off valve (where provided)

For connecting the electricity, see paragraph "Fuel shut-off valve VIC (not supplied)".

**⚠** Where a fuel shut-off valve (VIC) is to be installed on the diesel gas supply circuit to the burner, closure of the valve must be delayed to prevent the section of hose between the pump and the valve going into negative pressure (empty). In parameter 2079 you can set the time delay (seconds) on the closure of the VIC valve with respect to the burner. The value to be set must always be  $\geq$  the burner's post-ventilation time.

H (m)	L (m)	
	Øi (8mm)	Øi (10mm)
0	35	100
0,5	30	100
1	25	100
1,5	20	90
2	15	70
3	8	30
3,5	6	20

**H** = Height difference

**L** = Maximum length of suction hose

**Øi** = Internal diameter of hose

### NOTE:

The tables show the approximate maximum lengths for the supply line, depending on the height difference, length and diameter of the fuel line.

## 2.10 Discharge of combustion products

The smoke duct (1) and the chimney (2) must be made in accordance with the standards, current legislation and local regulations.

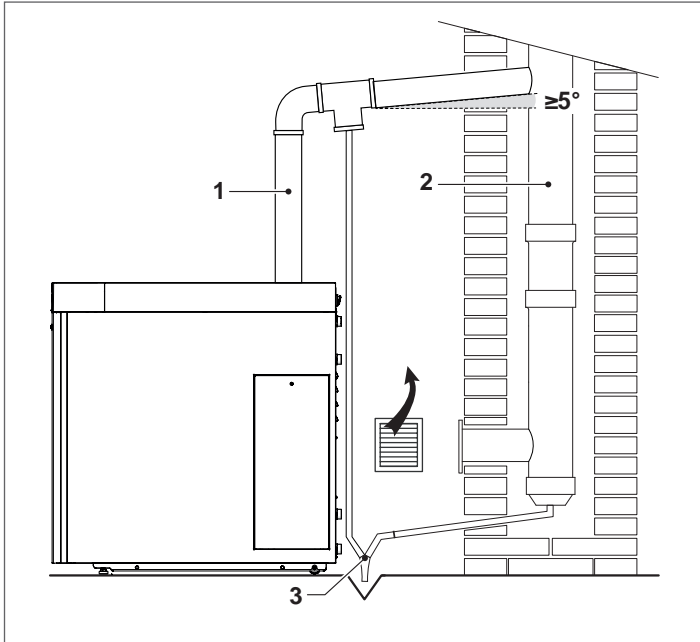

⚠ The condensate drain system (3) must conform to national and local legislation and standards.

⚠ The flue gas exhaust of the thermal unit is equipped with a seal (A) and a flue gas analysis outlet (B).

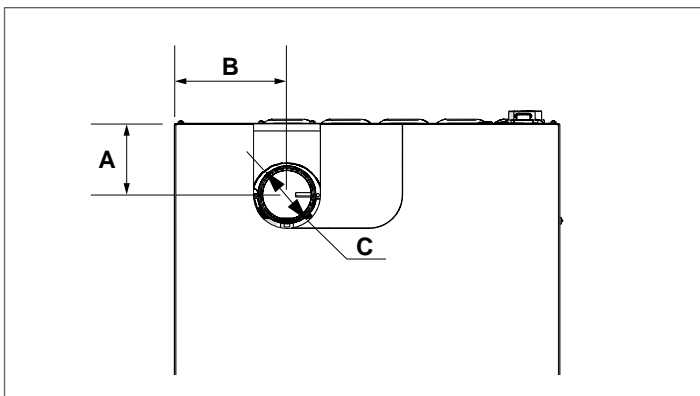
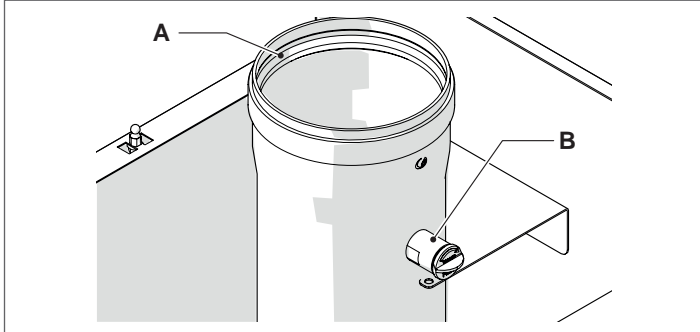

Description	INSIEME EVO COND			
	45 LN	55 LN	70 LN	
A		106		mm
B		150		mm
C		110		∅i

The thermal unit **INSIEME EVO COND LN** intakes the combustion air from the installation room through the ventilation openings that must be made in accordance with the Technical Standards.

⊘ Do not obstruct or restrict the air vents in the room where the boiler is installed. Adequate ventilation is essential for correct combustion and functioning.

### 2.10.1 Technical specifications of stack

The stack must satisfy the following requirements:

- It must be constructed from materials that are impermeable to flue gases and that offer lasting resistance to mechanical stress, heat and the action of the products of combustion and condensate
- It must be vertical, free of restrictions and contain bends of no more than 45°
- It must be suitable for the specific operating conditions of the boiler and must be CE marked
- It must be of adequate dimensions to ensure draught and venting properties suitable for the needs of the boiler
- It must have adequate external insulation to prevent condensation and the cooling of flue gases
- the stack must have a dedicated condensate drain system at the bottom.

⚠ The diameter of the smoke duct must never be smaller than the diameter of the flue gas duct of the thermal unit.

⚠ In configuration B23, the stack must guarantee the minimum draught specified by applicable technical standards, assuming zero pressure at the boiler's flue gas exhaust.

### 2.10.2 Connection to the stack

The boiler must be connected to the stack using rigid flue pipes that are resistant to heat, condensate and mechanical stress. All joints must be sealed and the finished flue must be insulated. Only use materials that are suitable for this purpose, e.g. stainless steel.

The near-horizontal section of flue pipe must have a slope of at least 5° towards the boiler and must also be properly insulated. In long near-horizontal sections of flue pipe (>1 m), install a condensate drain system near the boiler exhaust (as shown in the figure) to drain off any condensate forming in this section of flue.

The diameter of the stack must always be greater than that of the flue pipe from the boiler's exhaust fitting. To change direction, use a T section with an inspection cap to permit easy access for cleaning inside the pipe. After cleaning, always make sure that inspection caps are replaced tightly and that their seals are undamaged and efficient.

⚠ Flue pipes must maintain a distance of at least 500 mm from flammable or heat sensitive construction materials.

⚠ Joints must be sealed with materials that are resistant to acid condensate and to the high temperatures of the boiler's flue gases.

⚠ When installing flue pipes, always bear in mind the direction of the flue gases and of possible condensate flows.

⚠ Inadequate or badly dimensioned stacks and flues can increase combustion noise, cause condensation problems and affect combustion parameters.

⚠ Uninsulated flues are potentially dangerous and can cause burns.

**"OPEN" CONFIGURATION OF THE TYPE B BOILER**

The equipment is supplied as standard in type B configuration, hence prepared to suck air directly in the installation room through the venting openings, that must be carried out in compliance with the Technical Standards.

It can become a type C equipment with the use of specific accessories. In this configuration the equipment will suck air directly from the outside with the possibility to have coaxial or split pipes.

Description	INSIEME EVO COND			
	45 LN	55 LN	70 LN	
L <sub>MAX</sub>	20 (*)			m

(\*) This length must be reduced by 1 metre for every 90° curve and by 0.5 metres for every 45° curve.

**BOILER CONFIGURATIONS C "SEALED"**

If comburent air is drawn from outdoors, the appliances are type C "sealed" and the boiler room does not require ventilation.

**Split ducts (Ø 110 Air / Ø 110 Flue gases)**

For these configurations, the type C transformation accessory must be installed (following the instructions supplied with the accessory itself).

Split ducts can be oriented in the direction most suitable to the room needs, respecting the specified maximum lengths.

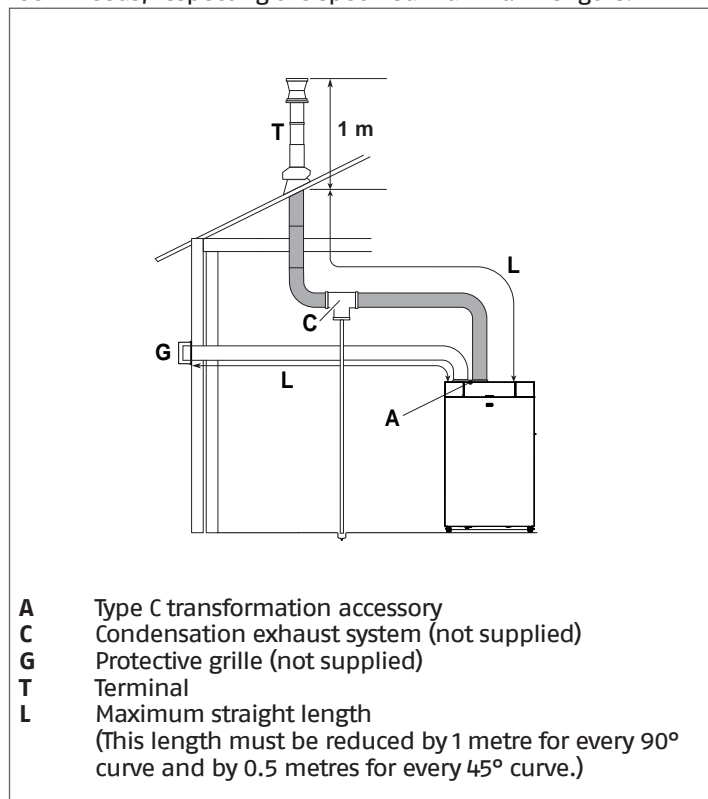

Description	INSIEME EVO COND			
	45 LN	55 LN	70 LN	
L <sub>MAX</sub> Exhaust flue duct	15 (*)			m
L <sub>MAX</sub> Air inlet	15 (*)			m

(\*) This length must be reduced by 1 metre for every 90° curve and by 0.5 metres for every 45° curve.

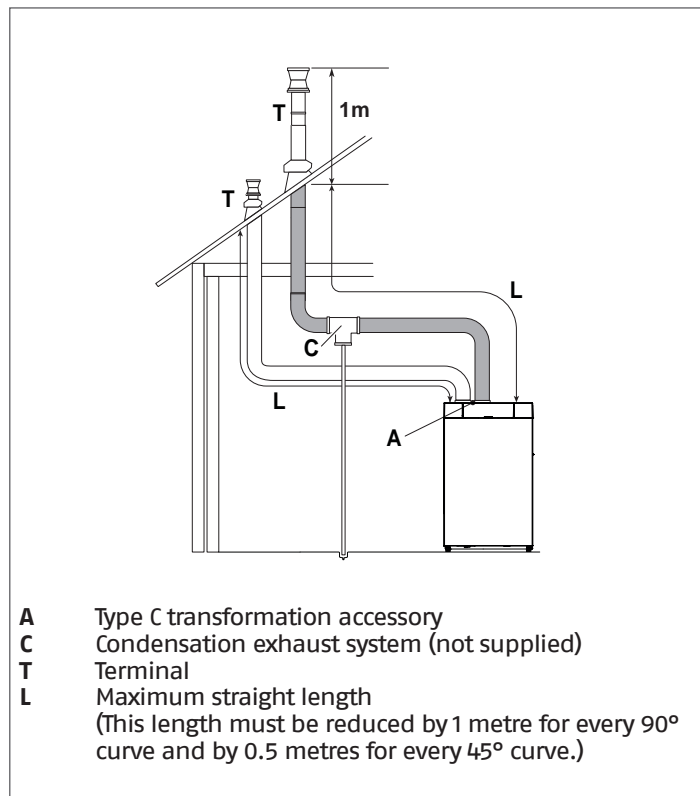

Description	INSIEME EVO COND			
	45 LN	55 LN	70 LN	
L <sub>MAX</sub> Exhaust flue duct	15 (*)			m
L <sub>MAX</sub> Air inlet	15 (*)			m

(\*) This length must be reduced by 1 metre for every 90° curve and by 0.5 metres for every 45° curve.

**⚠** Use of flues longer than the specified maximum leads to a loss of heat output from the boiler.

**⚠** Never obstruct or choke the comburent air intake pipe.

**Coaxial ducts (Ø 110/160)**

For these configurations, the type C transformation accessory and the concentric flue gas exhaust accessory must be installed (following the instructions supplied with the accessories themselves).

Coaxial flues can be oriented in whatever direction is most convenient for the room, provided the maximum specified lengths are respected.

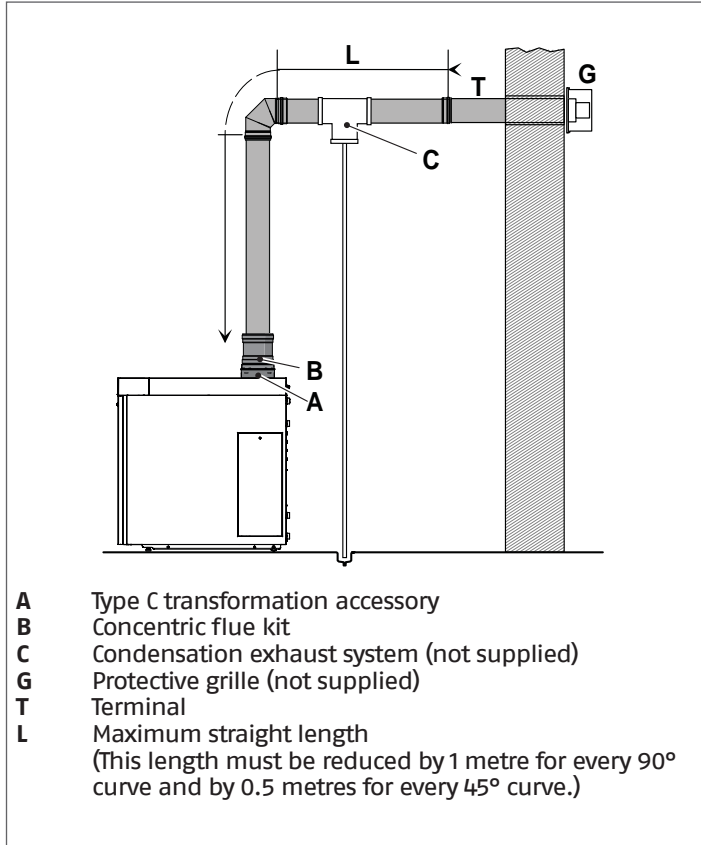

Description	INSIEME EVO COND			
	45 LN	55 LN	70 LN	
L <sub>MAX</sub>	7 (*)			m

(\*) This length must be reduced by 1 metre for every 90° curve and by 0.5 metres for every 45° curve.

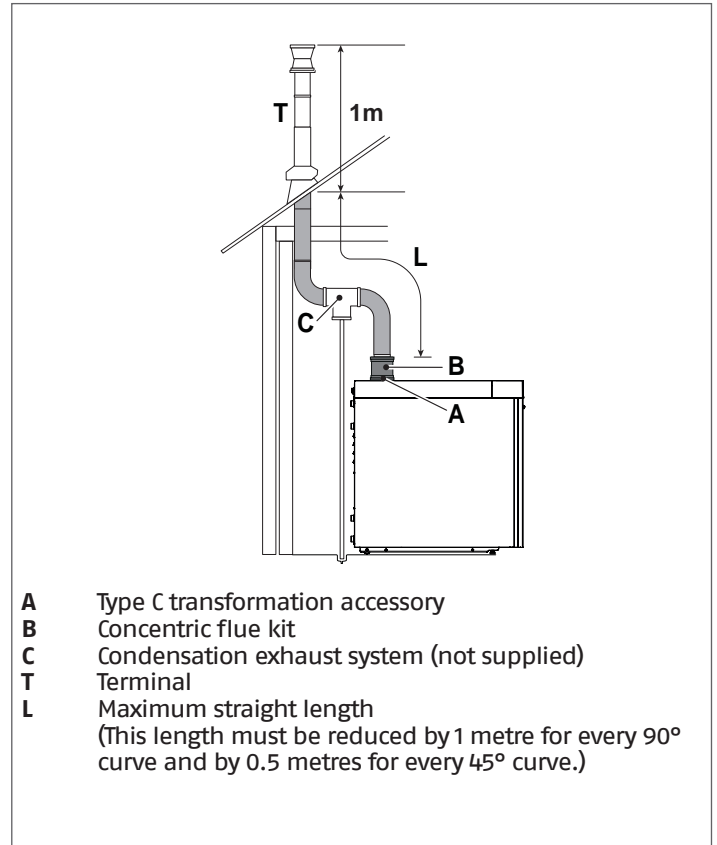

Description	INSIEME EVO COND			
	45 LN	55 LN	70 LN	
L <sub>MAX</sub>	7 (*)			m

(\*) This length must be reduced by 1 metre for every 90° curve and by 0.5 metres for every 45° curve.

**⚠** Use of flues longer than the specified maximum leads to a loss of heat output from the boiler.

**⚠** Never obstruct or choke the comburent air intake pipe.

### 2.10.3 Preparation for the condensate drain

**⚠** Always maintain a slope “i” of over 3° and ensure that the diameter of any hose used is greater than that of the boiler’s own condensate drain pipe.

**⚠** The connection to the drainage system must be made according to current laws in compliance with any local regulations.

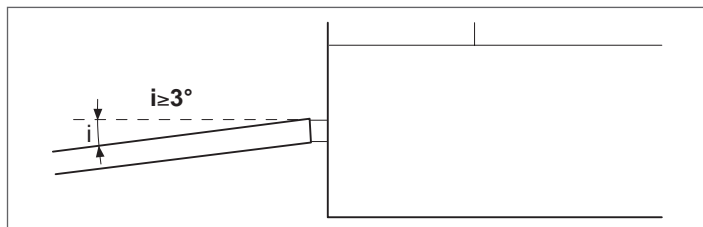

**⚠** Fill the siphon with water before you start up the boiler to prevent combustion gases escaping into the room during the first few minutes of boiler functioning.

**⚠** Condensate from the boiler and from the flue should be channelled to the same drain point.

**⚠** The base of the equipment must be horizontal and levelled in the frame resting area in order to let the condensate evacuate easily.

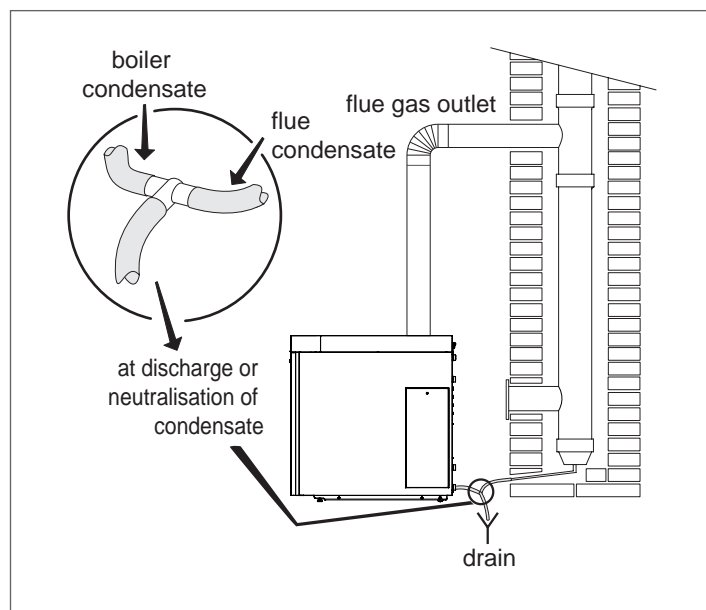

**⚠** Any condensate neutralisation devices can be connected after the siphon. For the calculation of the duration of the neutralisation load, the amount of neutraliser consumption must be evaluated after one year of operation. The total duration of the load can be extrapolated from this information.

**To select the type of neutralisation unit to use, consult the Catalogue or contact the dealer who sold the boiler.**

### 2.10.4 Neutralising the condensate

The **DNO 1**, **DNO 2**, **DNO 3**, **HNO 1.6** and **HNO 3** neutraliser kits are available for neutralising the condensate.

#### NEUTRALISATION KIT DNO 1

**DNO 1** neutralisers are designed for systems where the boiler room condensate drain point is located **BELOW** the boiler condensate outlet. This neutraliser does not require any electrical connections to be made.

#### NEUTRALISATION KIT DNO 2

**DNO 2** neutralisers are designed for systems where the boiler room condensate drain point is located **BELOW** the boiler condensate outlet. This neutraliser does not require any electrical connections to be made.

#### NEUTRALISATION KIT DNO 3

**DNO 3** neutralisers are designed for systems where the boiler room condensate drain point is located **BELOW** the boiler condensate outlet. This neutraliser does not require any electrical connections to be made.

#### NEUTRALISATION KIT HNO 1.6 – HNO 3

**HNO 1.6 – HNO 3** neutralisers are designed for systems where the boiler room condensate drain point is located **ABOVE** the boiler condensate outlet. This neutraliser requires electrical connections to be made.

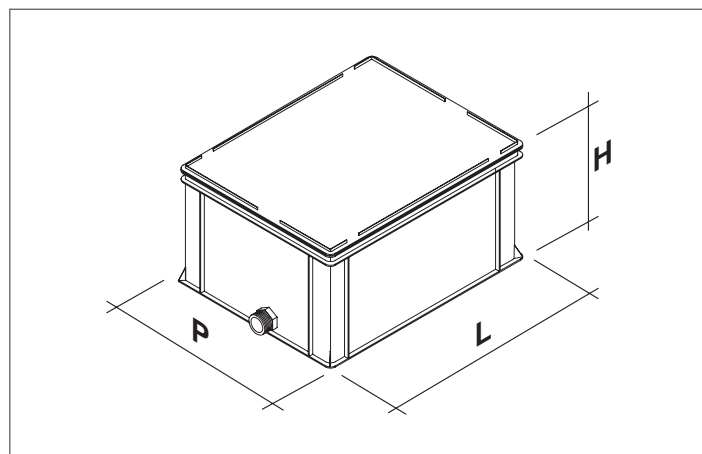

Description	DNO 1	DNO 2	DNO 3	HNO 1.6	HNO 3	
L - Width	330	420	640	640	940	mm
H - Height	230	240	240	240	340	mm
P - Depth	200	300	400	400	400	mm
Outlet hoses	G 1	G 1	G 1	G 1	G 1	inch
Drain hose	G 1	G 1	G 1	G 1	G 5/8	inch

**Technical specifications**

TYPE	DNO 1	DNO 2	DNO 3	HNO 1.6	HNO 3	
Quantity of activated carbon (approx.)	0,3	0,3	0,3	0,3	0,3	kg
Minimum granule quantity (approx.)	5	10	22	11	22	kg
Maximum granule consumption when filled (approx.)	7	15	38	16	38	kg
Maximum granule filling quantity (approx.)	11	25	60	27	60	kg
Max. hours at full load (approx.)	5500	2100	1600	3200	1600	hours
Maximum volumetric flow rate of condensate	4	24	80	16	110	l/h
Heat output of associated boiler	Up to 50	Up to 300	Up to 1000	Up to 200	Up to 1000	kW

**⚠** The installer is responsible for choosing the most suitable neutraliser, according to the appliance characteristics and the type of system.

**2.11 System filling and emptying**

For the thermal group **INSIEME EVO COND LN** it is necessary to provide a loading system to be connected on the return line of the device.

Before carrying out system filling and emptying operations, set the main switch of the system to OFF and the main switch of the equipment to (0).

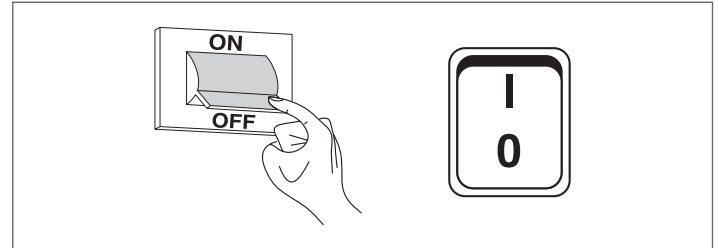

**2.11.1 Water quality requirements**

The manufacturer recommends the use of water as heat transfer fluid for the central heating system. A chemical treatment system must be provided for this water.

The heat transfer fluid (water) for the central heating circuit must conform to the quality parameters given in the following table:

REFERENCE VALUES	
pH	6-8
Electrical conductivity	less than 200 µS/cm (25°C)
Chlorine ions	less than 50 ppm
Sulphuric acid ions	less than 50 ppm
Total iron	less than 0.3 ppm
Alkalinity M	less than 50 ppm
Total hardness	less than 35°F
Sulphur ions	none
Ammonia ions	none
Silicon ions	less than 30 ppm

If the hardness of the water exceeds the value specified in the table, it is mandatory to install a water softening system.

**⚠** Excessive water softening (leading to a total hardness < 15°F) can cause corrosion in metal parts (pipes and boiler components). Keep the electrical conductivity of the water under 200 µS/cm.

**⊖** Do not top up the central heating circuit on a frequent or continuous basis as this can damage the boiler's heat exchanger. The use of automatic topping up systems should be avoided for this reason.

### 2.11.2 Filling

Before starting to recharge, check that the drain valve, on the system, is closed.

- Open the shut-off cocks for the water circuit

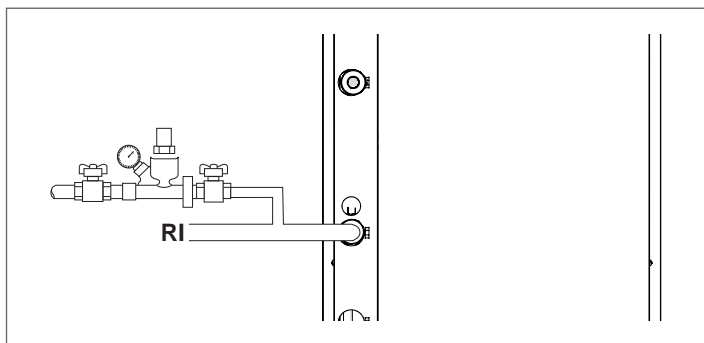

- Slowly load until the display shows the cold value of **1.5 bar**

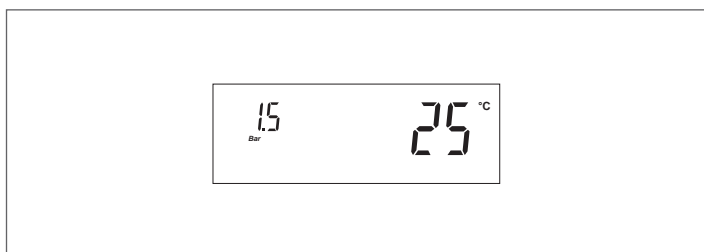

- Close the central heating circuit shut-off cocks.

**NOTE** The system is de-aerated automatically through the automatic vent valve.  
The drain pipe of the drain valve must be connected to a suitable collection system.

### 2.11.3 Emptying

Before emptying:

- Set the main switch of the system to OFF and the main switch of the equipment to (0).

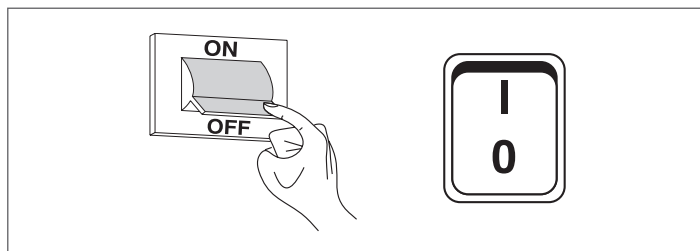

- Connect a plastic tube to the hose barb of the drain valve installed in the system and open it.

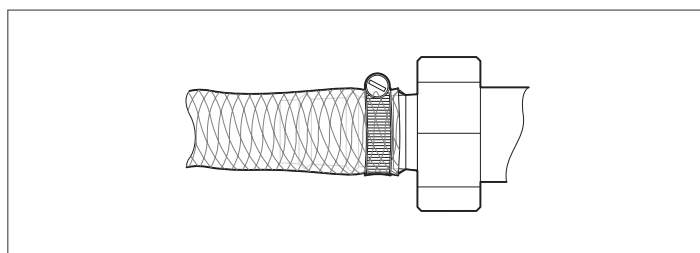

## 2.12 Wiring diagram

Mod. **INSIEME EVO COND 45 LN**

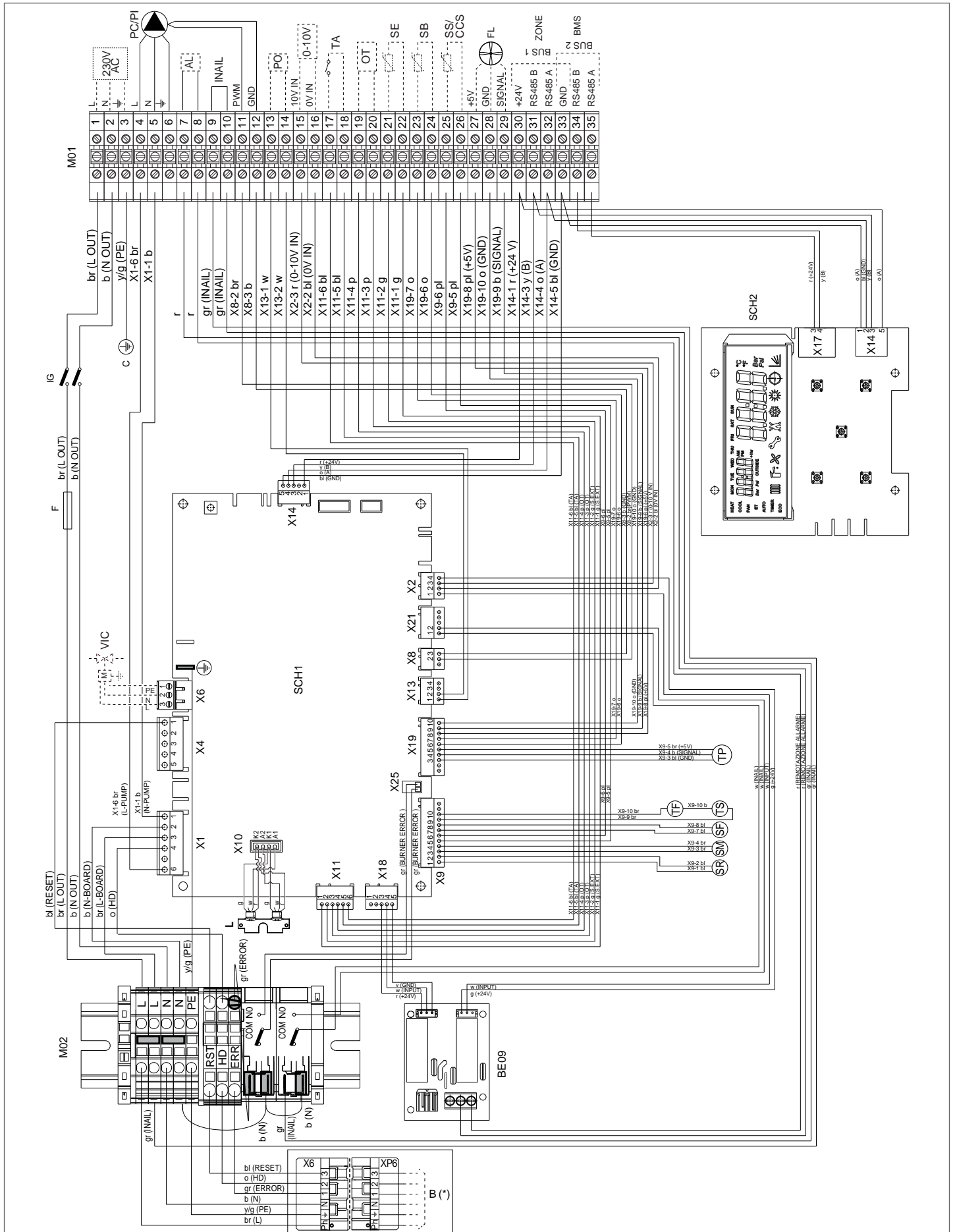

(\*) Please refer to section "Burner wiring diagram" on page 37.

<b>M01</b>	Terminal strip
<b>PC/PI</b>	Thermal unit pump/System pump (Par. 2033) (*)
<b>AL</b>	Remote activation of alarm (Par. 2031)
<b>INAIL</b>	INAIL safety measures (Par. 2029)
<b>PWM-GND</b>	PWM pump control output (Par. 2059-2060)
<b>PO</b>	Timer (Par. 2027-2045) (**)
<b>0-10V</b>	0-10V input (Par. 1063-2001-2025-2026)
<b>TA</b>	Room thermostat (Par. 2001)
<b>OT</b>	OpenTherm (Par. 2001)
<b>SE</b>	External sensor (Par. 2001)
<b>SB</b>	Hot water tank sensor/thermostat (Par. 2035)
<b>SS/CCS</b>	System sensor / cascade control sensor (Par. 2088)
<b>FL</b>	Flow meter/flow switch (Par. 2027)
<b>ZONES</b>	Modbus zone
<b>BMS</b>	Modbus
<b>IG</b>	Main switch
<b>C</b>	Ground conductor delivery
<b>F</b>	Mains power fuse 6.3 A-T
<b>VD</b>	3-way cock
<b>VIC</b>	Fuel shut-off valve (Par. 2030)
<b>M02</b>	Terminal strip
<b>L</b>	Light guide
<b>SCH1</b>	Main control board
<b>B</b>	Burner
<b>BE09</b>	Relay interface card
<b>SR</b>	Return probe
<b>SM</b>	Flow probe
<b>SF</b>	Exhaust flue probe

<b>TF</b>	Flue gas thermostat
<b>TS</b>	Safety thermostat
<b>TP</b>	Pressure transducer
<b>SCH2</b>	Display and control card

(\*) Circulator pump connection and PWM control by the installer.

(\*\*) Operation only with storage tank sensor (not applicable with storage tank thermostat).

<b>br</b>	brown
<b>b</b>	blue
<b>r</b>	red
<b>w</b>	white
<b>bl</b>	black
<b>y/g</b>	yellow/green
<b>y</b>	yellow
<b>gr</b>	grey
<b>g</b>	green
<b>o</b>	orange
<b>p</b>	pink
<b>pl</b>	violet

### 2.12.1 Burner wiring diagram

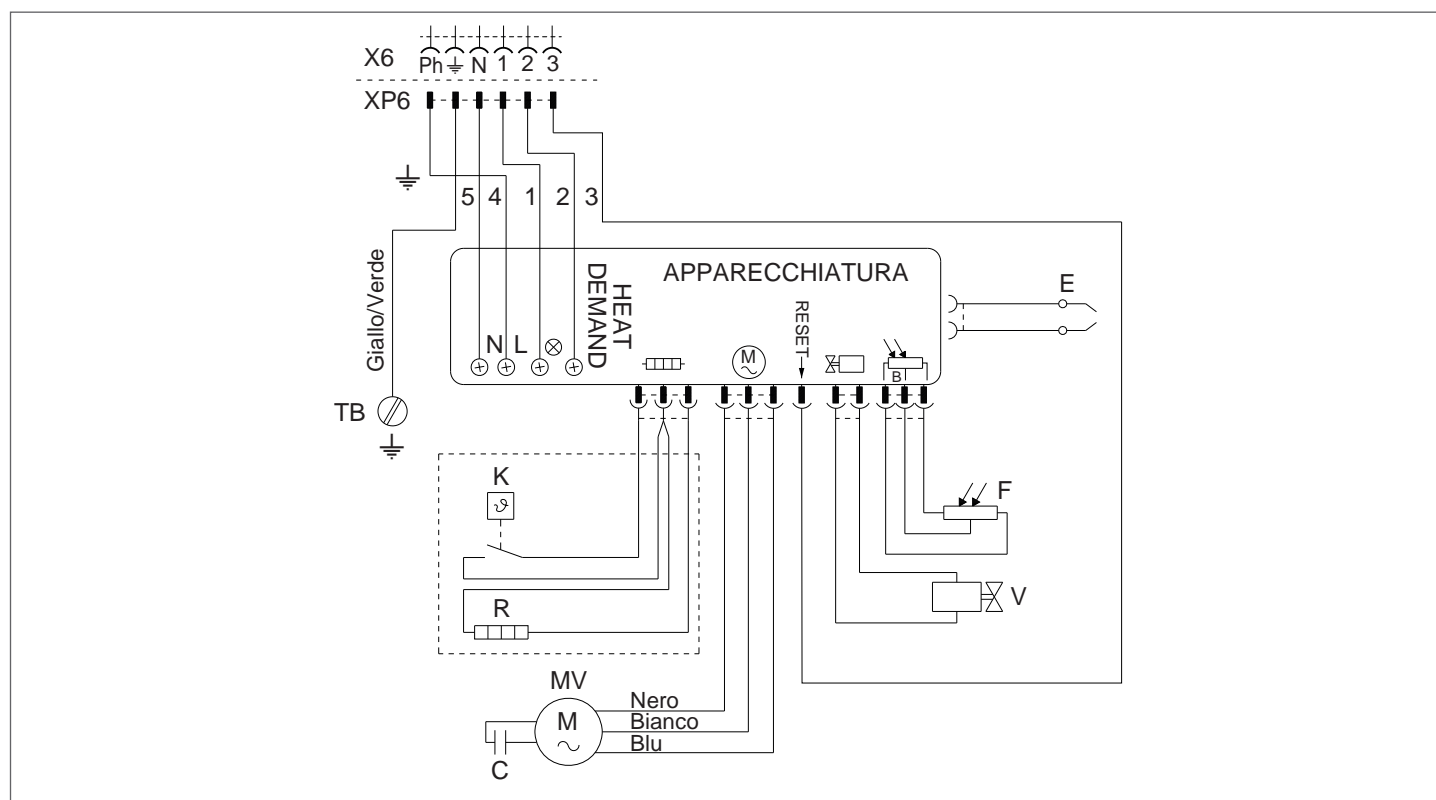

<b>C</b>	Condenser	<b>R</b>	Heating element
<b>E</b>	Electrodes	<b>TB</b>	Ground - Burner
<b>F</b>	Flame sensor	<b>V</b>	Fuel oil valve
<b>K</b>	Start enable thermostat after pre-heating	<b>X6</b>	6-pin plug
<b>MV</b>	Fan motor	<b>XP6</b>	6-pin socket



<b>MO1</b>	Terminal strip
<b>PC/PI</b>	Thermal unit pump/System pump (Par. 2033) (*)
<b>AL</b>	Remote activation of alarm (Par. 2031)
<b>INAIL</b>	INAIL safety measures (Par. 2029)
<b>PWM-GND</b>	PWM pump control output (Par. 2059-2060)
<b>PO</b>	Timer (Par. 2027-2045) (**)
<b>0-10V</b>	0-10V input (Par. 1063-2001-2025-2026)
<b>TA</b>	Room thermostat (Par. 2001)
<b>OT</b>	OpenTherm (Par. 2001)
<b>SE</b>	External sensor (Par. 2001)
<b>SB</b>	Hot water tank sensor/thermostat (Par. 2035)
<b>SS/CCS</b>	System sensor / cascade control sensor (Par. 2088)
<b>FL</b>	Flow meter/flow switch (Par. 2027)
<b>ZONES</b>	Modbus zone
<b>BMS</b>	Modbus
<b>IG</b>	Main switch
<b>C</b>	Ground conductor delivery
<b>F</b>	Mains power fuse 6.3 A-T
<b>VD</b>	3-way cock
<b>VIC</b>	Fuel shut-off valve (Par. 2030)
<b>MO2</b>	Terminal strip
<b>L</b>	Light guide
<b>SCH1</b>	Main control board
<b>B</b>	Burner
<b>R1</b>	Second stage burner NO relay
<b>R2</b>	Alarm remoting NO relay
<b>BE09</b>	Relay interface card

<b>SR</b>	Return probe
<b>SM</b>	Flow probe
<b>SF</b>	Exhaust flue probe
<b>TF</b>	Flue gas thermostat
<b>TS</b>	Safety thermostat
<b>TP</b>	Pressure transducer
<b>SCH2</b>	Display and control card

(\*) Circulator pump connection and PWM control by the installer.  
 (\*\*) Operation only with storage tank sensor (not applicable with storage tank thermostat).

<b>br</b>	brown
<b>b</b>	blue
<b>r</b>	red
<b>w</b>	white
<b>bl</b>	black
<b>y/g</b>	yellow/green
<b>y</b>	yellow
<b>gr</b>	grey
<b>g</b>	green
<b>o</b>	orange
<b>p</b>	pink
<b>pl</b>	violet

2.12.2 Burner wiring diagram

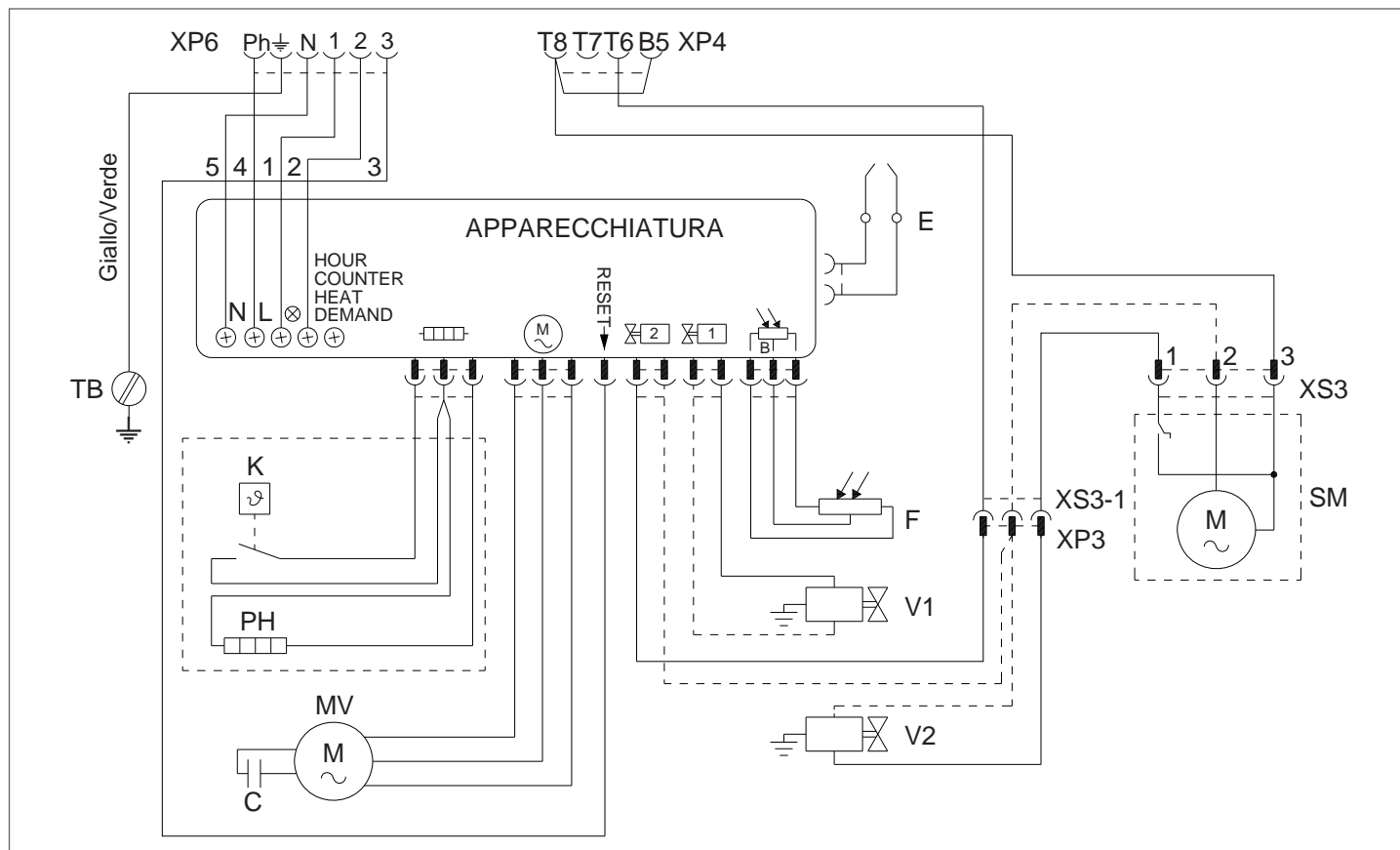

<b>C</b>	Condenser	<b>SM</b>	Air damper opener servomotor
<b>E</b>	Electrodes	<b>TB</b>	Burner ground
<b>F</b>	Flame sensor	<b>V1</b>	1st stage light oil valve
<b>K</b>	Start enable thermostat after pre-heating	<b>V2</b>	2nd stage light oil valve
<b>MV</b>	Fan motor	<b>XP..</b>	Socket
<b>PH</b>	Heating element		

**Fuel shut-off valve VIC (not supplied)**

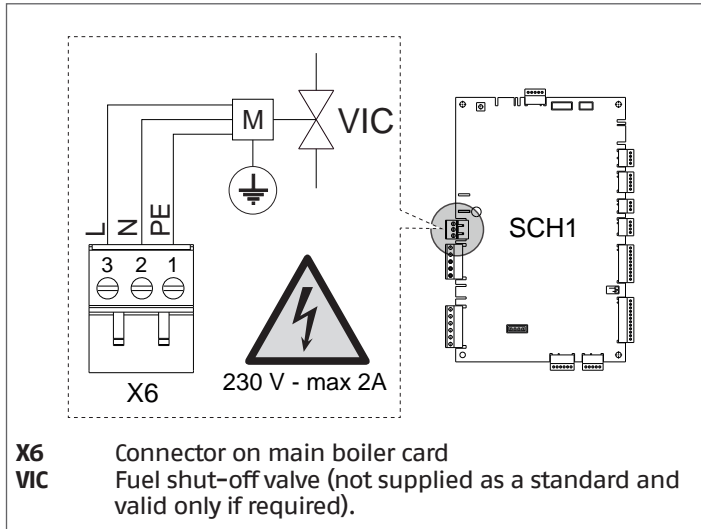

**⚠** Check that the value 1 (default) is set at parameter 2030. If the burner's post-ventilation time is changed, a value (in seconds)  $\geq$  the value just set on the burner must be set in parameter 2079.

**Diverter valve VD (not supplied)**

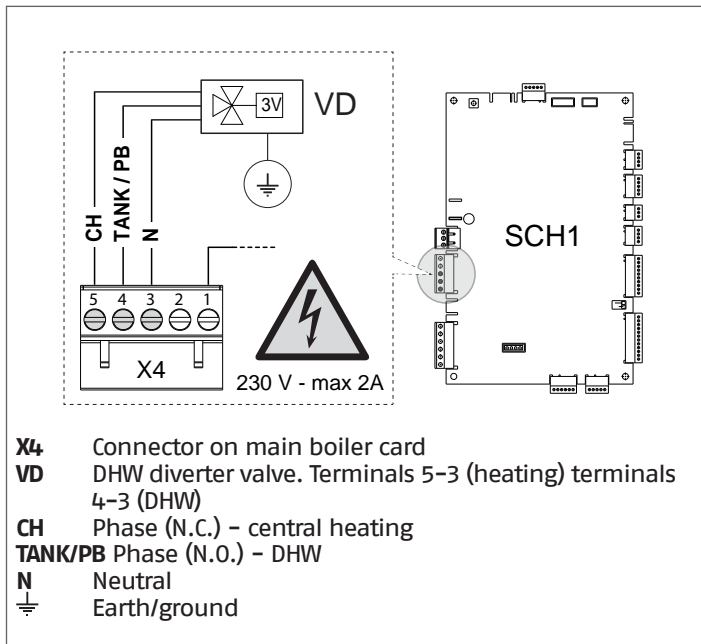

**Tank pump PB (not supplied)**

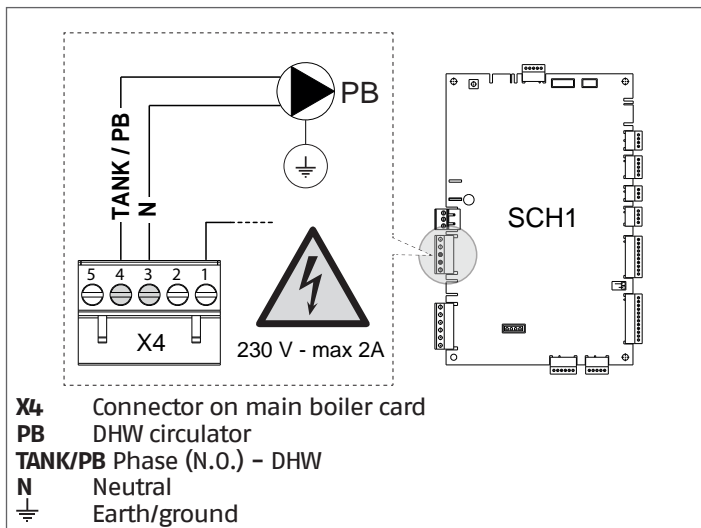

**2.13 Electrical connections**

The thermal unit **INSIEME EVO COND LN** exits the factory completely wired and only requires the connection to the power supply network, the room thermostat and any other components of the system.

Proceed as follows to access the control panel terminals:

- open the control panel door and remove the fixing screw (2);
- remove the front panel (1) and lift it by pulling it towards yourself;

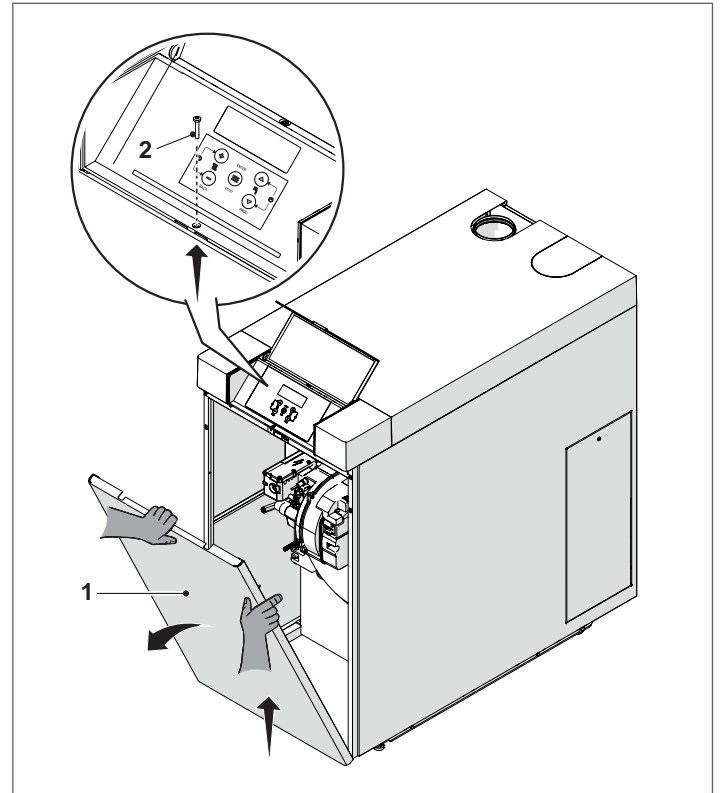

- remove the fixing screw (3) from the top of the control panel;

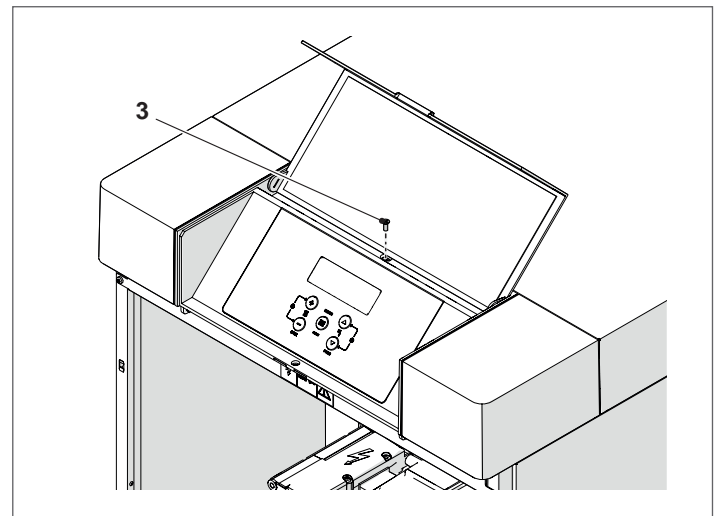



## 2.14 Menu navigation

At start-up or when no key is pressed for more than 4 minutes, the display is in "basic display" mode and provides general information on the equipment operation.

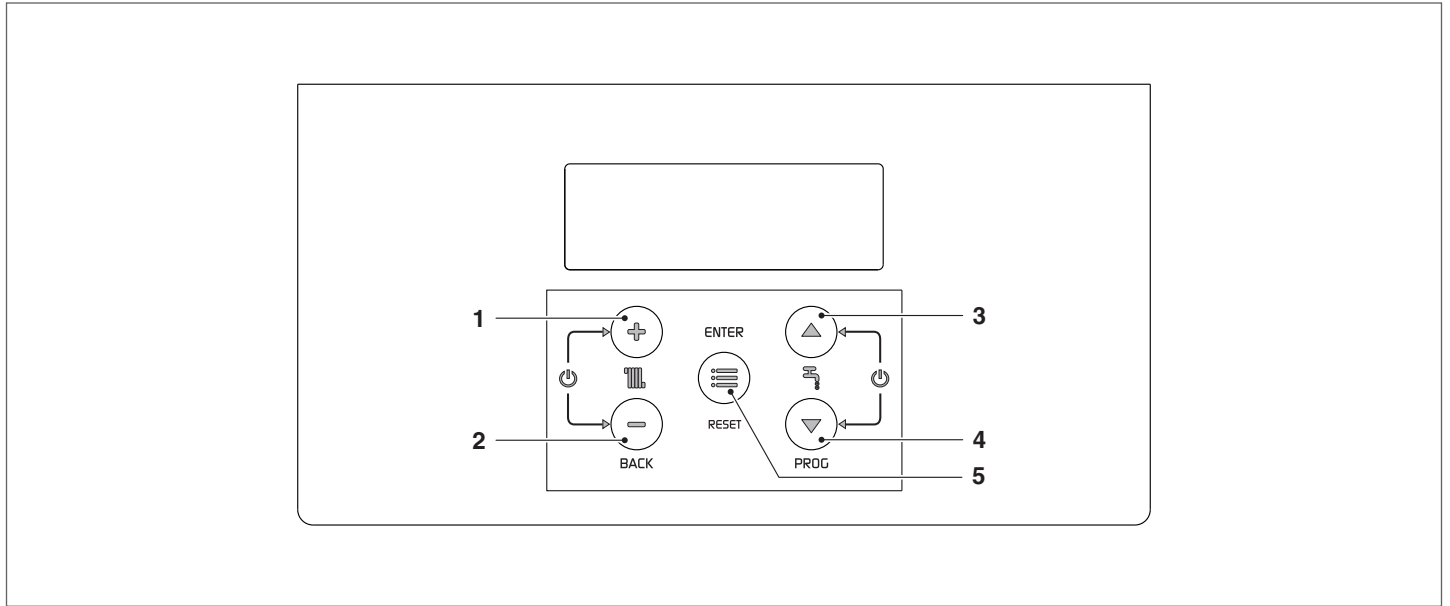

In this mode, keys have the following functions:

Nr.	Button	Function
1	"+"	It increases the heating setpoint (when active/available)
2	"-"	It decreases the heating setpoint (when active/available)
3	"▲"	Raise the DHW set point (when available)
4	"▼"	Decrease the DHW set point (when available)
5	"ENTER/RESET"	Enters into "MENU" mode If pressed for more than 5 seconds, it resets a permanent error (Loc)

Additional functions:

Button	Function
"+" with "-"	It accesses enable/disable heating function mode
"▲" + "▼"	It accesses enable/disable DHW production function mode

For more information, see paragraph "Enable/disable the heating function" on page 52.

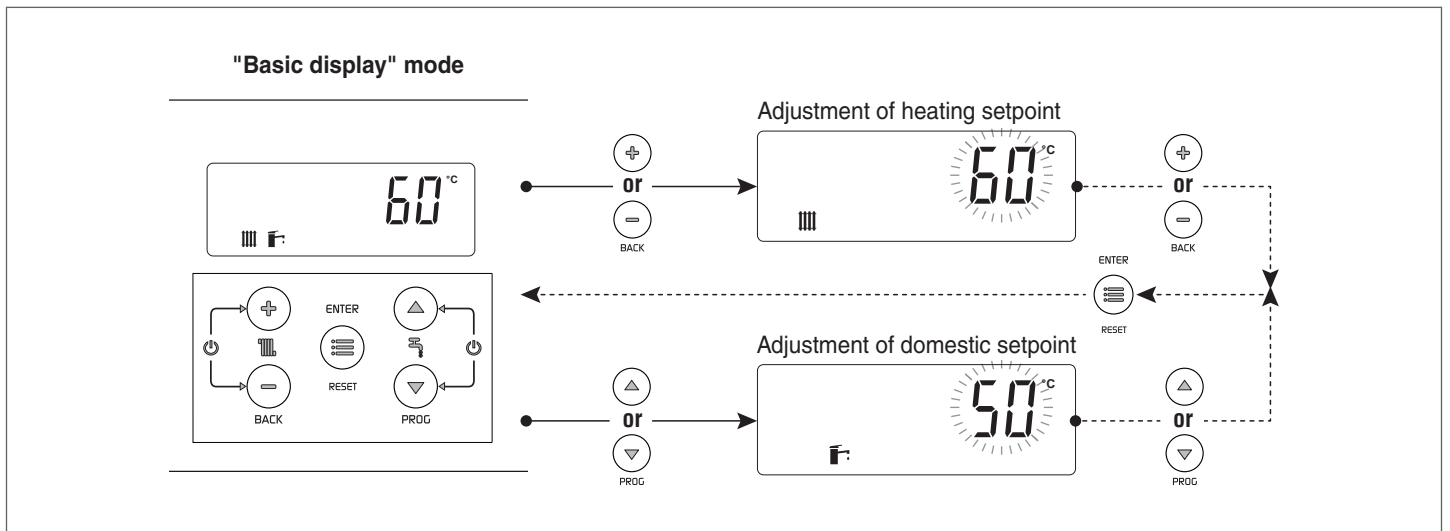

### MENU selection

Access the "menu" mode by pressing the key "ENTER/RESET". The digits of the small display indicate "0000", which is the first accessible menu.

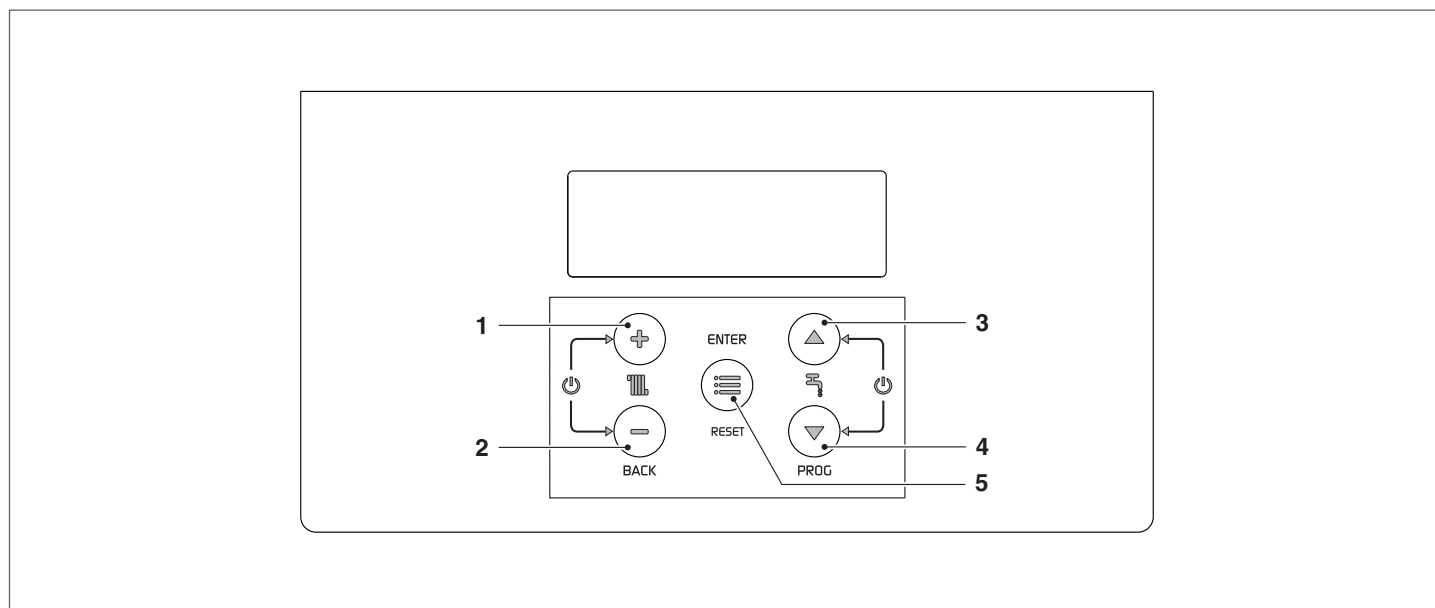

In this mode, keys have the following functions:

Nr.	Button	Function
1	"+"	Exits from the menu and cancels a parameter change
2	"-"	Exits from the menu and cancels a parameter change
3	"▲"	Selects the following menu or increases a certain parameter value
4	"▼"	Selects the previous menu or decreases a certain parameter value
5	"ENTER/RESET"	Enters into the selected menu/parameter or confirms the parameter change

### 2.15 Enter password

To access INSTALLER parameters, it is necessary to enter the password:

- Press the key "ENTER/RESET" and select "Code" by using the keys "▲" and "▼".

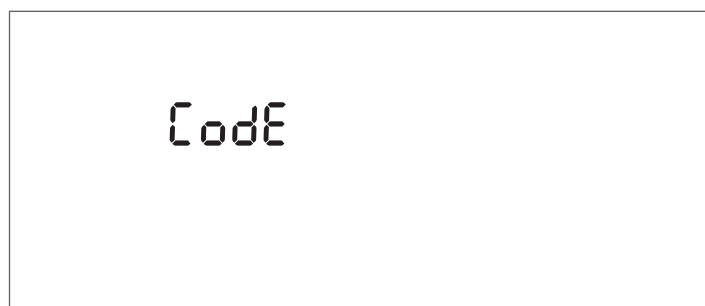

- Press the key "ENTER/RESET" to confirm

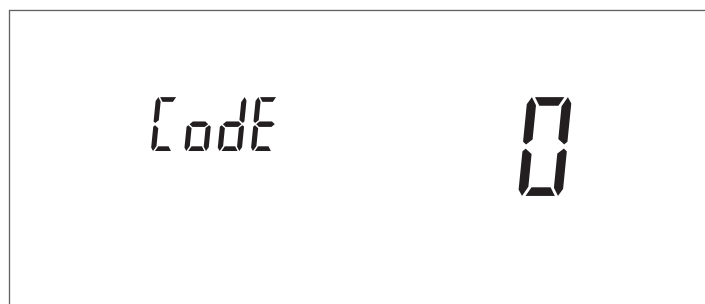

- Press the keys "▲" and "▼" to increase or decrease the value of the blinking digit
- Once the required value is obtained, press the key "ENTER/RESET" to confirm the entered value

After entering the INSTALLER password the relevant menus and parameters will also be displayed.

The system provides for three types of access:

- USER: new password
- INSTALLER: password 18

**!** After entering the password, the display will show the symbol  which will be displayed until the displaying and/or parametrisation proceed. After some minutes of inactivity of the display, it must be entered again.

## 2.16 Navigation scheme

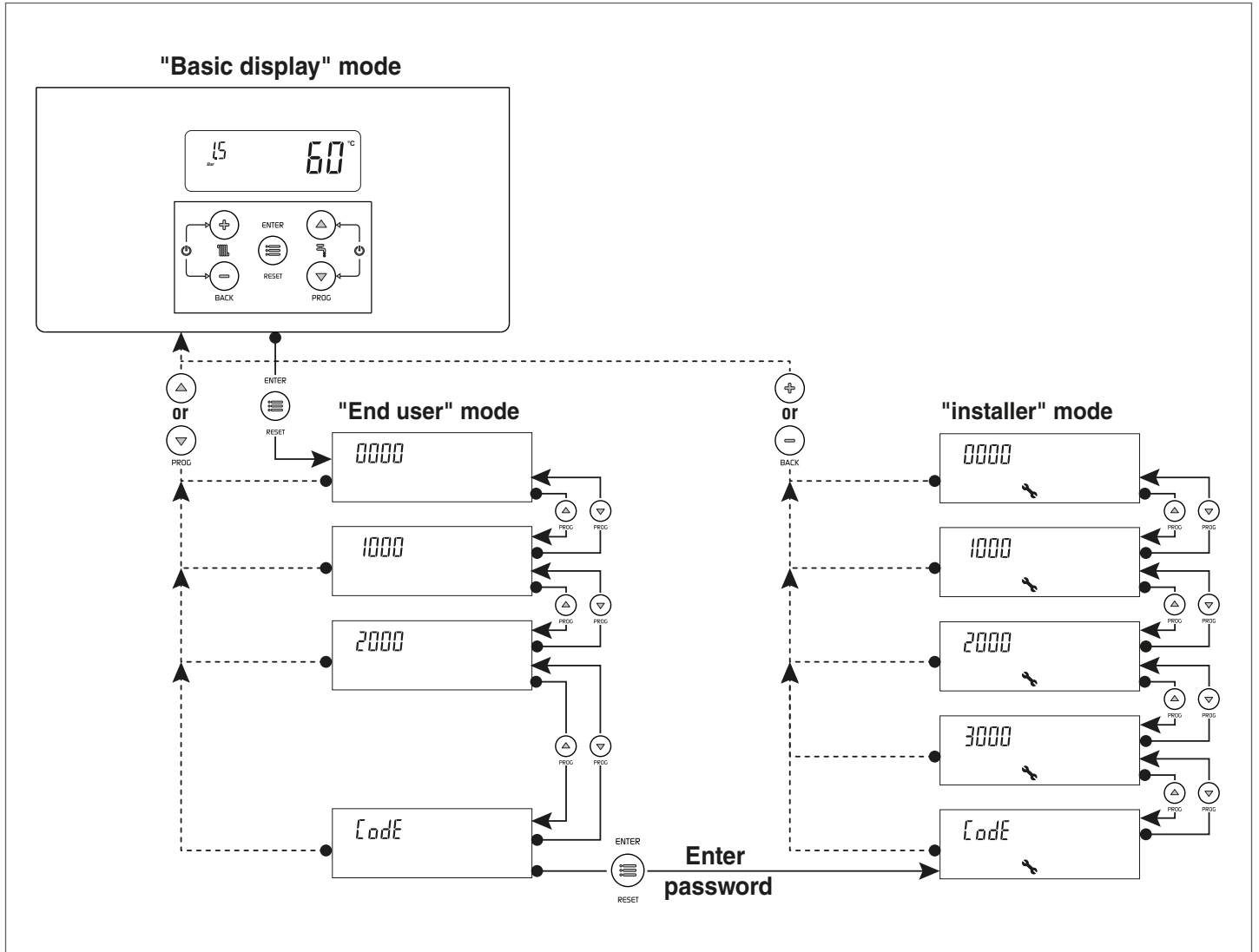

### Example of parameter setting

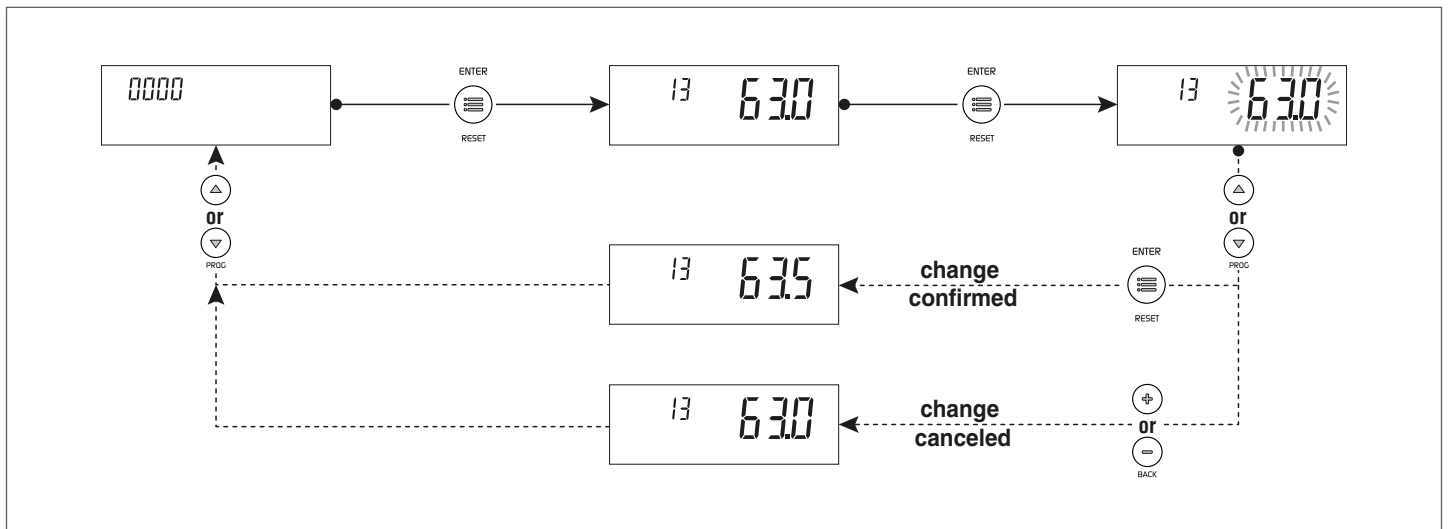

## 2.17 List of parameters

**⚠** The programming lines can be hidden, according to the access level (User, Installer) and to the thermal unit configuration.

**Access level:**  
 U: End user  
 I: Installer

**⚠** The parameters of Installer level must be changed only by the Technical Assistance Service RIELLO.

**Key:**  
**DHW** Domestic hot water  
**HT** High temperature direct circuit  
**BT** Low temperature mixed circuit  
**DCW** Domestic cold water  
**OT** OpenTherm  
**SA** Ambient probe  
**SE** Outdoor sensor  
**TA** Room thermostat

Menu	Par. No.	Description	Range	Default setting INSIEME EVO COND LN	UM	Access
<b>Main menu</b>						
0000	013	Quick adjustment of direct Zone/Zone 1 heating setpoint in 0 and 3 heating modes. By connecting the zone control accessory, this parameter can be used to quickly change direct Zone/Zone 1 setpoint. This parameter simultaneously modifies the value of Par. 2103.	See Par. 2103	See Par. 2103	°C	U
0000	023	Quick adjustment of Zone 2 heating setpoint in 0 and 3 heating modes. By connecting the zone control accessory, this parameter can be used to quickly change Zone 2 setpoint. This parameter simultaneously modifies the value of Par. 2203.	See Par. 2203	See Par. 2203	°C	U
0000	033	Quick adjustment of Zone 3 heating setpoint in 0 and 3 heating modes. By connecting the zone control accessory, this parameter can be used to quickly change Zone 3 setpoint. This parameter simultaneously modifies the value of Par. 2303.	See Par. 2303	See Par. 2303	°C	U
0000	047	Quick adjustment of DHW setpoint with heater This parameter is only visible with Par. 2035 = 1	See Par. 2047		°C	U
0000	200	Test mode 0 = None 1 = Stops the chimney sweep function 2 = Starts the chimney sweep function Stops the venting function	0...2	0		I
0000	201	0 = No action 1 = Stop venting Visible only when de-aeration is in operation	0...1	0		U
0000	901	Unit of measurement for temperature 0 = °C 1 = °F	0...1	0		I
0000	902	Pressure unit of measurement 0 = BAR 1 = PSI	0...1	0		I
<b>Info menu</b>						
1000	1001	CH flow temperature			°C	U
1000	1002	Domestic hot water temperature			°C	U
1000	1004	Outside temperature			°C	U
1000	1006	Displays the flue temperature			°C	U
1000	1007	Return temperature			°C	U
1000	1033	System pressure			bar	U
1000	1056	Total hours of operation in heating mode			h x 10	U
1000	1057	Total hours of operation in domestic mode			h x 10	U
1000	1058	Total hours of operation			h x 10	U
1000	1062	Displays the flow meter flow rate Display active only with Par. 2027 = 1			l/min.	U
1000	1063	Input signal 0-10V			V	U
1000	1090	Counts down the days to the next service (if it's past, a negative value is shown) If the value is < 15 the service icon flashes			Days	U
1000	1101	Direct Zone/Zone 1 delivery temperature			°C	U
1000	1102	Direct Zone/Zone 1 ambient temperature			°C	U

Menu	Par. No.	Description	Range	Default setting INSIEME EVO COND LN	UM	Access
1000	1112	Zone 1 heating setpoint			°C	U
1000	1201	Zone 2 delivery temperature			°C	U
1000	1202	Zone 2 ambient temperature			°C	U
1000	1212	Zone 2 heating setpoint			°C	U
1000	1301	Zone 3 delivery temperature			°C	U
1000	1302	Zone 3 ambient temperature			°C	U
1000	1312	Zone 3 heating setpoint			°C	U
<b>Heating general settings</b>						
2000	2001	Heating operating mode 0 = Operation with fixed setpoint and ambient thermostat 1 = Operation with climatic curve and ambient thermostat 2 = Continuous operation with climatic curve and night reduction with ambient thermostat 3 = Continuous operation with fixed setpoint and night reduction with ambient thermostat 4 = Operation with variable setpoint with input signal 0-10V	0...4	0		I
2000	2005	Circulator post-circulating time in heating mode	10...900	120	Sec.	I
2000	2007	Switch-off hysteresis in heating mode	0...5	3	°C	I
2000	2008	Ignition hysteresis in heating mode	0...5	3	°C	I
2000	2009	Burner restart time It defines the stand-by time for a subsequent restart after a switch-off, regardless of the delivery temperature decrease. If it goes below the value set in Par. 2010 the thermal unit remains on.	10...900	180	Sec.	I
2000	2010	Temperature differential for burner restart It defines the temperature difference below which the burner restarts regardless of the elapsed time indicated in Par. 2009.	0...20	16	°C	I
2000	2011	Temperature differential for the deactivation of the burner's second stage in heating mode This parameter can only be seen on boilers with a dual stage burner	0...10	5	°C	I
2000	2012	Burner second stage ignition hysteresis in heating mode This parameter can only be seen on boilers with a dual stage burner	0...10	5	°C	I
2000	2013	Temperature differential for the deactivation of the burner's second stage in DHW mode This parameter can only be seen on boilers with a dual stage burner	0...10	5	°C	I
2000	2014	Burner second stage ignition hysteresis in DHW mode This parameter can only be seen on boilers with a dual stage burner	0...10	5	°C	I
2000	2016	Heating pump proportional part PID	0...100	20		I
2000	2017	Heating pump additional part PID	0...600	50		I
2000	2018	Heating pump derivative part PID	0...100	50		I
2000	2019	Heating flow meter minimum flow rate Setting a value = 0 deactivates the function	0...200	5	l/min.	I
2000	2020	Type of flow meter 1= HUBA DN15 2= HUBA DN20 3= HUBA DN25 4= HUBA DN32	1...4	1		I
2000	2021	Number of days to next service		365	Days	U
2000	2022	Service reminder This function reminds the user of the need to carry out a programmed service on the boiler, after the number of days set in Par. 2021 0 = Deactivates the function 1 = Activates the function 2 = Resets the countdown of days to next service to zero	0...2	0		U
2000	2023	Minimum heating setpoint	20, Par. 2024	20	°C	I
2000	2024	Maximum heating setpoint	Par. 2023, 90	82	°C	I
2000	2025	Minimum 0-10V input voltage in heating mode Par. 2001= 4	0...10	1	V	I
2000	2026	Maximum 0-10V input voltage in heating mode Par. 2001= 4	0...10	9	V	I

Menu	Par. No.	Description	Range	Default setting INSIEME EVO COND LN	UM	Access
2000	2027	Programmable input 2 0 = Disabled 1= Heating flow meter 2= Heating flow switch 3= Function not implemented	0...3	0		I
2000	2028	Programmable input 1 0= Disabled 1= Pressure transducer (with temporary or permanent alarm) 2= Pressure transducer (without alarms) (*) (*) Use only when the system is working at low pressure (open tank systems)	0...2	1		I
2000	2029	Programmable input 8 0= Disabled 1= Heating pressure switch	0...1	1		I
2000	2030	Programmable output 1 0= Disabled 1= VIC (fuel shut-off valve) relay output on	0...1	1		I
2000	2031	Programmable output 3 0= Disabled 1= Remote alarm on	0...1	1		I
2000	2032	Programmable output 2 0= Disabled 1= 3-way valve with DHW storage tank before the separator 2= 3-way valve with instant DHW version 3= DHW storage tank pump (see label inside boiler electrical panel)	0...3	0		I
2000	2033	Programmable output 4 1= Thermal unit pump 2= System pump	0...2	1		I
2000	2059	Minimum pump modulation value with central heating heat request	0...Par. 2060	40	%	I
2000	2060	Maximum pump modulation value with central heating heat request	Par. 2059...100	100	%	I
2000	2078	Set service hours countdown 0= Burner's hours of operation 1 = Boiler's hours of operation	0...1	0		U
2000	2079	Time delay on closing VIC (fuel shut-off valve) When the burner goes off the VIC valve stays open for the time set by this parameter	0...180	60	Sec.	I
2000	2080	Anti-legionella function 0 = deactivated 1 = daily 2 = weekly	0...2	0		I
2000	2088	Function not implemented				I
2000	2090	Venting function 0 = deactivated 1 = activated	0...1	1		I
2000	2091	Number of de-aeration cycles Each cycle includes two ON/OFF sequences, each having 10 seconds ON and 10 seconds OFF. Factory setting anticipates 2 de-aeration cycles every time that the de-aeration function comes on. 1st cycle: the boiler's 3-way diverter valve moves to the central heating position and the boiler pump comes on for 10 seconds, goes off for 10 seconds, comes back on for 10 seconds and then goes off again for 10 seconds. This cycle lasts 40 seconds. 2nd cycle: begins at the end of the 1st cycle. The 3-way diverter valve moves to the DHW position and the pump repeats the same ON/OFF procedures as above, for a total of 40 seconds.	0...255	2		I
2000	2092	Number of repetitions of de-aeration cycles This parameter sets the number of repetitions for each de-aeration cycle set in Par. 2091. The sequence of de-aeration cycles is carried out for the number of times set in this parameter. Based on the factory settings of parameters 2091= 2 and 2092= 10, the total duration of the de-aeration function is 800 seconds (2 cycles of 40 sec. 10 times).	0...255	10		I

Menu	Par. No.	Description	Range	Default setting INSIEME EVO COND LN	UM	Access
2000	2093	Setting use of room thermostat (TA) where there is OpenTherm (OT) connection 0 = Uses only OT communication. The heat request and the setpoint are communicated only via OpenTherm. 1 = Uses room thermostat (TA) to activate heat request and OT to communicate the setpoint requested to the boiler (*). (* ) When setting parameter = 1 in a central heating system managed with zone valves, where there is an OT room thermostat for each valve, the OT room thermostat will control the opening and closing of the respective valve (zone) and the valve microswitch, connected to terminal TA of the boiler, will control (ON/OFF) the heat request. If both requests (OT and TA) are active, the OT request will be fulfilled.	0...1	0		I
<b>Direct Zone / Zone 1 Heating Settings</b>						
2000	2103	Direct Zone/Zone 1 setpoint in heating mode Par. 2001= 0 and 3 The thermal unit adjustment determines the boiler setpoint in heating mode, using the highest value among the requests of all the active zones (Par. 1101, 1201, 1301) If Zone 1 is configured as mixed, the value set in parameter 1112 will be used as setpoint	If Zone 1 is not enabled: (Par. 2121) If Zone 1 is enabled: BT: (Par. 2121, 45) AT: (Par. 2121)	70 (AT) 45 (BT)	°C	U
2000	2119	Direct Zone/Zone 1 heating setpoint at the minimum external temperature	If Zone 1 is not enabled: (Par. 2121) If Zone 1 is enabled: BT: (Par. 2121, 45) AT: (Par. 2121)	82 (AT) 45 (BT)	°C	I
2000	2120	Direct Zone/Zone 1 minimum external temperature It defines the minimum external temperature to which the heating maximum setpoint in Par. 2119 must be associated	-20...5	-20	°C	I
2000	2121	Direct Zone/Zone 1 heating setpoint at the maximum external temperature (Par. 2122) It sets the minimum heating setpoint when the external temperature is equal to the value set in parameter 2122 (basic external temperature)	If Zone 1 is not enabled: (Par. 2119) If Zone 1 is enabled: BT: (20, Par. 2119) AT: (Par. 2119)	30 (AT) 20 (BT)	°C	I
2000	2122	Direct Zone/Zone 1 maximum external temperature It sets the external temperature at which the boiler setpoint must be reduced, according to the value defined in parameter 2121	5...30	20	°C	I
2000	2125	Direct Zone/Zone 1 summer/winter switching It stops the request in heating mode when the external temperature is higher than this setpoint	0...35	20	°C	I
2000	2130	Parallel shift of direct Zone/Zone 1 climatic curve	-10...10	0	°C	U
2000	2131	Direct Zone/Zone 1 mild climate temperature compensation	0...20	0	°C	I
2000	2132	Direct Zone/Zone 1 ambient temperature nominal value When an OpenTherm (OT) ambient thermostat is connected to the thermal unit or to the zone control accessory, this parameter is not displayed	5...35	20	°C	I
2000	2133	Direct Zone/Zone 1 setpoint night reduction in heating mode Par. 2001= 2 or 3 It defines by how many degrees the heating setpoint will be reduced at the opening of the ambient thermostat (AT) contact The reduction of the delivery temperature affects all the active heating zones and it can be used when the AT terminal of every zone regulator is jumpered.	0...10	4	°C	I
2000	2134	Compensation factor of direct Zone/Zone 1 external temperature	0...100	50	%	I
2000	2135	Zone 1 mixing valve closing time	0...240	140	Sec.	I
2000	2136	Zone 1 mixing valve PID P	0...99	5		I
2000	2137	Zone 1 mixing valve PID I	0...99	10		I
2000	2138	Zone 1 valve operating time	0...255	2	Sec. x 10	I
2000	2139	Zone 1 setpoint increase Increases the value of the heating zone setpoint. For example, if the zone setpoint is 40°C, the heat request sent to the boiler will be increased by 5°C (factory setting), therefore the value requested at the boiler will be 45°C. Valid only for mixed zone.	0...20	5	°C	I
2000	2140	Zone 1 circulator post-circulating time	0...240	30	Sec.	I

Menu	Par. No.	Description	Range	Default setting INSIEME EVO COND LN	UM	Access
2000	2141	Zone 1 delivery overtemperature protection	0...100	55	°C	I
2000	2142	Zone 1 overtemperature control time	0...240	0	Min.	I
2000	2143	Zone 1 overtemperature stand-by time	0...240	2	Min.	I
2000	2144	Zone 1 system reset time	0...240	2	Min.	I
2000	2500	Function not implemented				I
2000	2501	Function not implemented				I
3000	3100	Use of Zone 1 control accessory 0 = NO 1 = Yes  If Zone 1 control accessory is used, AT and AP inputs are not enabled. AT input is used only to enable the night reduction on all the active zones (Par. 2001 = 2 and 3)	0...1	0		I
3000	3101	Zone 1 mode 0 = direct 1 = mixed	0...1	0		I
<b>Zone 2 Heating Settings</b>						
2000	2203	Zone 2 heating setpoint in 0 and 3 heating modes The thermal unit adjustment determines the boiler setpoint in heating mode, using the highest value among the requests of all the active zones (Par. 1101, 1201, 1301) If Zone 2 is set as mixed, the value set in parameter 1212 will be used as the setpoint.	BT: (Par. 2221, 45) AT: (Par. 2221)	70 (AT) 45 (BT)	°C	U
2000	2219	Zone 2 maximum heating setpoint at the minimum external temperature	BT: (Par. 2221, 45) AT: (Par. 2221)	82 (AT) 45 (BT)	°C	I
2000	2220	Zone 2 minimum external temperature It defines the minimum external temperature to which the maximum heating setpoint Par. 2219 must be associated.	-20...5	-20	°C	I
2000	2221	Zone 2 minimum heating setpoint at basic external temperature (Par. 2222) It sets the minimum heating setpoint when the external temperature is equal to the value set in parameter 2222 (basic external temperature).	BT: (20, Par. 2219) AT: (Par. 2219)	30 (AT) 20 (BT)	°C	I
2000	2222	Zone 2 basic external temperature It sets the external temperature at which the boiler setpoint must be reduced, according to the value defined in parameter 2221.	5...30	20	°C	I
2000	2225	Zone 2 summer/winter switching It blocks the heating request when the external temperature is greater than this setpoint.	0...35	20	°C	I
2000	2230	Parallel shift of direct Zone/Zone 1 climatic curve	-10...10	0	°C	U
2000	2231	Zone 2 mild climate temperature compensation	0...20	0	°C	I
2000	2232	Zone 2 ambient temperature nominal value When an OpenTherm (OT) ambient thermostat is connected to the zone control accessory, this parameter is not used.	5...35	20	°C	I
2000	2233	Zone 2 setpoint night reduction in heating mode (Par. 2001= 2 or 3) It defines by how many degrees the heating setpoint will be reduced at the opening of the ambient thermostat (AT) contact The reduction of the delivery temperature affects all the active heating zones and it can be used when the AT terminal of every zone regulator is jumpered.	0...10	4	°C	I
2000	2234	Compensation factor of Zone 2 external temperature	0...100	50	%	I
2000	2235	Zone 2 mixing valve closing time	0...240	140	Sec.	I
2000	2236	Zone 2 mixing valve PID P	0...99	5		I
2000	2237	Zone 2 mixing valve PID I	0...99	10		I
2000	2238	Zone 2 valve operating time	0...255	2	Sec. x 10	I
2000	2239	Zone 2 setpoint increase Increases the value of the heating zone setpoint. For example, if the zone setpoint is 40°C, the heat request sent to the boiler will be increased by 5°C (factory setting), therefore the value requested at the boiler will be 45°C. Valid only for mixed zone.	0...20	5	°C	I
2000	2240	Zone 2 circulator post-circulating time	0...240	30	Sec.	I
2000	2241	Zone 2 delivery overtemperature protection	0...100	55	°C	I
2000	2242	Zone 2 overtemperature control time	0...240	0	Min.	I
2000	2243	Zone 2 overtemperature stand-by time	0...240	2	Min.	I

Menu	Par. No.	Description	Range	Default setting INSIEME EVO COND LN	UM	Access
2000	2244	Zone 2 system reset time	0...240	2	Min.	I
3000	3200	Use of Zone 2 control accessory 0 = NO 1 = Yes If Zone 2 control accessory is used, AT and OT inputs are not enabled. AT input is used only to enable the night reduction on all the active zones (Par. 2001= 2 and 3)	0...1	0		I
3000	3201	Zone 2 mode 0 = direct 1 = mixed	0...1	0		I
<b>Zone 3 Heating Settings</b>						
2000	2303	Zone 3 heating setpoint in 0 and 3 heating modes The thermal unit adjustment determines the boiler setpoint in heating mode, using the highest value among the requests of all the active zones (Par. 1101, 1201, 1301) If Zone 3 is set as mixed, the value set in parameter 1312 will be used as the setpoint.	BT: (Par. 2321, 45) AT: (Par. 2321)	70 (AT) 45 (BT)	°C	U
2000	2319	Zone 3 maximum heating setpoint at the minimum external temperature	BT: (Par. 2321, 45) AT: (Par. 2321)	82 (AT) 45 (BT)	°C	I
2000	2320	Zone 3 minimum external temperature It defines the minimum external temperature to which the maximum heating setpoint Par. 2319 must be associated.	-20...5	-20	°C	I
2000	2321	Zone 3 minimum heating setpoint at basic external temperature (Par. 2322) It sets the minimum heating setpoint when the external temperature is equal to the value set in parameter 2322 (basic external temperature).	BT: (20, Par. 2319) AT: (Par. 2319)	30 (AT) 20 (BT)	°C	I
2000	2322	Zone 3 basic external temperature It sets the external temperature at which the boiler setpoint must be reduced, according to the value defined in parameter 2321.	5...30	20	°C	I
2000	2325	Zone 3 summer/winter switching It blocks the heating request when the external temperature is greater than this setpoint.	0...35	20	°C	I
2000	2330	Parallel shift of direct Zone/Zone 1 climatic curve	-10...10	0	°C	U
2000	2331	Zone 3 mild climate temperature compensation	0...20	0	°C	I
2000	2332	Zone 3 ambient temperature nominal value When an OpenTherm (OT) ambient thermostat is connected to the zone control accessory, this parameter is not used.	5...35	20	°C	I
2000	2333	Zone 3 setpoint night reduction in heating mode (Par. 2001 = 2 or 3) It defines by how many degrees the heating setpoint will be reduced at the opening of the ambient thermostat (AT) contact The reduction of the delivery temperature affects all the active heating zones and it can be used when the AT terminal of every zone regulator is jumpered	0...10	4	°C	I
2000	2334	Compensation factor of Zone 3 external temperature	0...100	50	%	I
2000	2335	Zone 3 mixing valve closing time	0...240	140	Sec.	I
2000	2336	Zone 3 mixing valve PID P	0...99	5		I
2000	2337	Zone 3 mixing valve PID I	0...99	10		I
2000	2338	Zone 3 valve operating time	0...255	2	Sec. x 10	I
2000	2339	Zone 3 setpoint increase Increases the value of the central heating zone setpoint. For example, if the zone setpoint is 40°C, the heat request sent to the boiler will be increased by 5°C (factory setting), therefore the value requested from for the boiler will be 45°C. Valid only for mixed zone.	0...20	5	°C	I
2000	2340	Zone 3 circulator post-circulating time	0...240	30	Sec.	I
2000	2341	Zone 3 delivery overtemperature protection	0...100	55	°C	I
2000	2342	Zone 3 overtemperature control time	0...240	0	Min.	I
2000	2343	Zone 3 overtemperature stand-by time	0...240	2	Min.	I
2000	2344	Zone 3 system reset time	0...240	2	Min.	I

Menu	Par. No.	Description	Range	Default setting INSIEME EVO COND LN	UM	Access
3000	3300	Use of Zone 3 control accessory 0 = NO 1 = Yes If Zone 3 control accessory is used, AT and OT inputs are not enabled. AT input is used only to enable the night reduction on all the active zones (Par. 2001 = 2 and 3).	0...1	0		I
3000	3301	Zone 3 mode 0 = direct 1 = mixed	0...1	0		I
<b>DHW settings and system configuration</b>						
2000	2035	Domestic operating mode 0 = DHW disabled 1 = DHW with heater 10 = DHW instant production	0...10	0		I
2000	2036	Hysteresis for heater DHW request start If the heater temperature goes below the DHW setpoint minus the hysteresis value defined in this parameter, the regulator confirms the fulfilment of the request.	0...5	3	°C	I
2000	2037	Hysteresis for heater DHW request stop If the heater temperature goes above the DHW setpoint plus the hysteresis value defined in this parameter, the regulator confirms the stop of the request.	0...5	3	°C	I
2000	2038	Thermal unit delivery temperature increase in DHW mode with heater It increases the delivery temperature to the boiler by the value set in this parameter.	0...20	15	°C	I
2000	2041	Primary setpoint for heater with thermostat	50...82	75	°C	I
2000	2042	Heat request priority 0 = DHW has priority over heating during the time set in Par. 2043. 1 = Heating mode priority 2 = Domestic mode priority 3 = Parallel	0...3	2		I
2000	2043	Time for which the priority is alternately assigned to domestic and heating circuits when the Par. 2042 is set to "0" mode (for heater only).	0...120	60	Min.	I
2000	2044	Circulator post-circulating time in domestic mode.	10...900	120	Sec.	I
2000	2045	Enabling DHW timer input for storage tank 0 = DHW always enabled 1 = DHW enabled by timer Not applicable with storage tank thermostat	0...1	0		I
2000	2047	DHW setpoint with heater This parameter is only visible with Par. 2035 = 1	40...65	57	°C	U
2000	2052	DCW minimum temperature setpoint of DHW exchanger (it activates pump and diverting valve on domestic circuit) Parameter valid only for thermal units with a plate heat exchanger (IDHW)	10...35	25	°C	I
2000	2053	DCW maximum temperature setpoint of DHW exchanger (it deactivates pump and diverting valve on domestic circuit) Parameter valid only for thermal units with a plate heat exchanger (IDHW)	10...43	25	°C	I
2000	2061	Boiler shutdown threshold when producing instant DHW. Temperature refers to delivery sensor Parameter valid only for thermal units with a plate heat exchanger (IDHW)	40...82	80	°C	I
2000	2062	Upper temperature hysteresis above the boiler shutdown threshold when producing instant DHW (Par. 2061) Parameter valid only for thermal units with a plate heat exchanger (IDHW)	0...3	1	°C	I
2000	2063	ΔT boiler delivery / boiler return Parameter valid only for thermal units with a plate heat exchanger (IDHW)	5...40	15	°C	I
2000	2064	Minimum pump modulation value in instant DHW production mode Parameter valid only for thermal units with a plate heat exchanger (IDHW)	0...Par. 2065	40	%	I

Menu	Par. No.	Description	Range	Default setting INSIEME EVO COND LN	UM	Access
2000	2065	Maximum pump modulation value in instant DHW production mode Parameter valid only for thermal units with a plate heat exchanger (IDHW)	Par. 2064...100	100	%	I
2000	2074	Burner anti-freeze protection 0 = NO 1 = Yes	0...1	1		I
2000	2075	Heating circuit anti-freeze protection 0 = Disabled 1 = Always on (an external sensor must be installed) 2 = Activates with the heating ON. If the heating is turned off (summertime) the antifreeze protection does not come on	0...2	0		I
2000	2076	DHW anti-freeze protection 0 = NO 1 = YES	0...1	0		I
2000	2077	DHW anti-freeze protection time	0...24	12	Hours	I
2000	2099	Burner ignition stand-by time It delays the burner ignition after the opening of the solenoid valve on the fuel supply pipeline	0...60	0	Sec.	I
<b>Error log</b>						
9000	9001	Error log - 1	0...9999			U
9000	9002	Error log - 2	0...9999			U
9000	9003	Error log - 3	0...9999			U
9000	9004	Error log - 4	0...9999			U
9000	9005	Error log - 5	0...9999			U
9000	9006	Error log - 6	0...9999			U
9000	9007	Error log - 7	0...9999			U
9000	9008	Error log - 8	0...9999			U
9000	9009	Error log - 9	0...9999			U
9000	9010	Error log - 10	0...9999			U

### 3 COMMISSIONING AND MAINTENANCE

#### 3.1 Preparing for initial startup

The first start-up of the thermal unit must be carried out by the Technical Assistance Service.

Perform the following checks before starting up the boiler:

- Check that the fuel shut-off cock and heating system shut-off cock are open

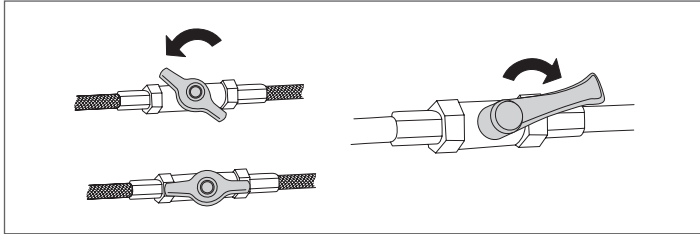

- the pressure of the hydraulic circuit, with cold water, is **1.5 bar** (value indicated on the first screen of the control panel display) and the circuit is not vented

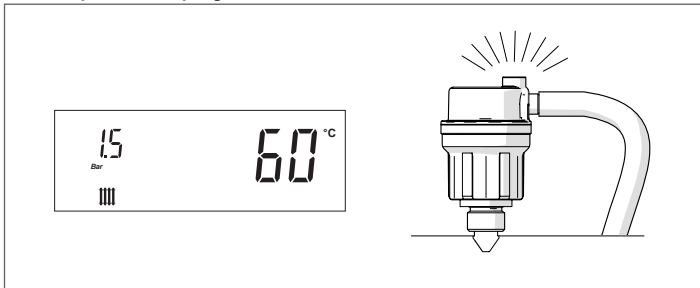

- Check that the expansion vessel is correctly pre-charged
- the electric connections have been made correctly
- Check that the flue and air vents are made to applicable laws and standards.

#### 3.2 Initial startup

Once you have completed all the checks listed above, proceed as follows to start up the boiler for the first time:

- set the main switch of the system to ON and the main switch of the equipment to (I).

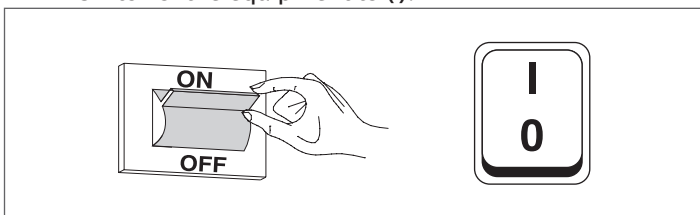

Upon switching on, the display of the control interface of the device shows the following pages in sequence.

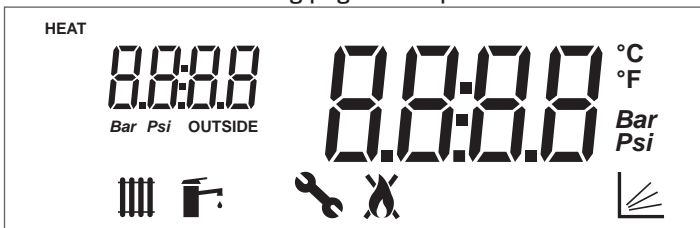

Firmware version of the thermal unit interface.

In the example the message indicates a firmware version = 0.



Communication test between interface and regulator.

The message "init" will appear briefly to indicate the beginning of the communication between the interface and regulator inside the thermal unit (\*).



Firmware version of the thermal unit regulator.

In the example the message indicates a firmware version = 1.



At first start-up and at every restoration of the power supply the venting function signalled by the message "Air" activates.

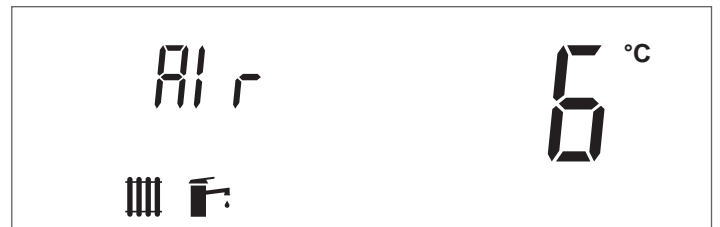

The vent cycle lasts 14 minutes.



(\*). If the communication test fails the message "no COMM" will appear



Once the initialization phase is complete, the display switches to "basic display" mode.

In this mode, the main information on the equipment operation is displayed. The meaning of the different icons displayed is explained in paragraph "Control panel". The icon  and the heating delivery temperature are displayed, either if the boiler is in stand-by mode or if a temperature request is active (icon  blinking).

To switch off the equipment, set the main switch to "0".

 Never power off the appliance before switching the master switch to the "0" position.

 Never switch off the appliance with the master switch if a request is active. Always make sure that the appliance is in stand-by before switching the main switch.

**Example of generator stand-by display in heating only mode (external probe not connected)**



- Set the room thermostat to the required temperature (~ 20°C) or, if the system has a timer or timer-thermostat, make sure that this is switched "ON" and adjusted to the required temperature (~ 20°C);

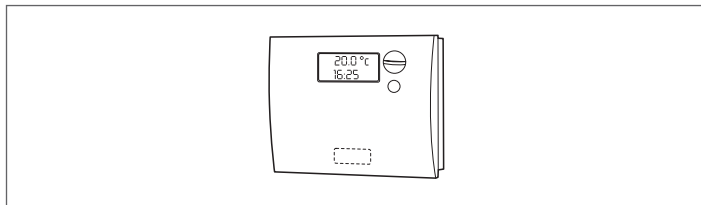



 In certain conditions, the "Heating circuit anti-freeze protection" function (Par. 2075 = 1) activates the appliance circulator and burner (see section "Special functions") by raising the heating system temperature, even where there is no heat request.

 If the "Heating circuit anti-freeze protection" function is deactivated (Par. 2075 = 0), the heating circuit is not protected against freezing during periods of inactivity.

**3.2.1 Adjustment of heating setpoint**

- Press the key "+" or "-" to display the current value of the heating temperature setpoint.



- Increase or decrease the setpoint according to the type of system by using the key "+" of "-".
- To save the modification made and go back to the initial screen, wait for 3 seconds or press the key "ENTER/RESET".
- Check that the thermal unit starts the ignition phase and that the display shows the icon  blinking (ambient heating request) and the icon .
- The thermal unit ignition phase will start only after the light oil pre-heating phase will be completed and will remain active until the set temperature will be reached.

**3.2.2 Enable/disable the heating function**

- Press the keys "+" and "-" simultaneously for a few seconds;
- The icon  and the current heating mode (ON or OFF) will blink on the display;



- Press the keys "+" and "-" to select the required mode;
- Press the key "ENTER/RESET" or wait for 3 seconds to save the modification made and go back to the initial screen.

**3.2.3 Enable/disable the domestic function**

- Press the keys "▲" and "▼" simultaneously for a few seconds;
- The icon  and the current domestic mode (ON or OFF) will blink on the display;



- Press the keys "▲" and "▼" to select the required mode;
- To save the modification made and go back to the initial screen, press the key "ENTER/RESET".

### 3.2.4 Adjustment of domestic setpoint

- Press the key "▲" or "▼" to display the current value of domestic setpoint.

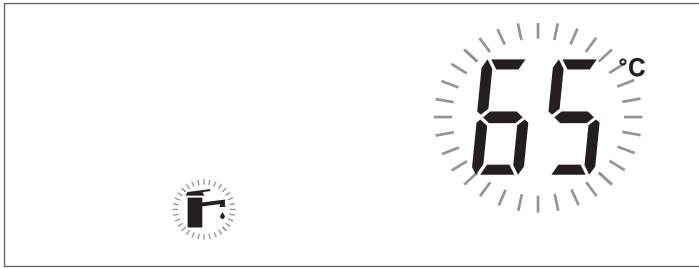

- Increase or decrease the setpoint by using the key "▲" or "▼".
- To save the modification made and go back to the initial screen, press the key "ENTER/RESET".

### 3.2.5 Setting the heating parameters

The thermoregulation on the thermal unit uses pre-configurations which allow to simplify the first start-up operations. There are five boiler operating modes in heating mode (Par. 2001). The basic configuration of the parameter 2001 is 0. The parameters to be set on the regulator will vary according to the selected operating mode.

**Mode 0:** operation with ambient thermostat (AT)/heat request

In this mode:

- External probe is not required.
- The OpenTherm (OT) communication is not enabled and any OT thermostat connected is supplied but signals a "communication error".
- Input 0-10V is not used.
- The Modbus communication is enabled. If a device is connected to the Modbus, the zone regulator works in priority to the ambient thermostat (AT/OT).

The thermal unit thermoregulation manages the heating delivery temperature with a fixed setpoint defined in Par. 2103. The setpoint value can be directly set, without having to access the list of parameters as indicated in paragraph "Menu navigation" on page 40.

The setpoint can be set within a range defined by par. 2023 (minimum) and 2024 (maximum) as indicated in the figure.

The parameters regulating such temperature are:

Par. No.	Description
2103	Main Zone/Zone 1 setpoint in heating mode Par. 2001 = 0 and 3. The thermal unit adjustment determines the boiler setpoint in heating mode, using the highest value among the requests of all the active zones (Par. 1101, 1201, 1301). If Zone 1 is set as mixed, the value set in parameter 1112 will be used as setpoint.
2023	Minimum heating setpoint.
2024	Maximum heating setpoint.

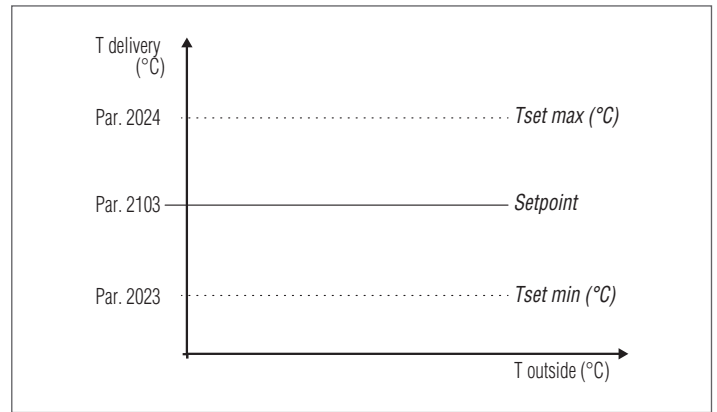

**Mode 1:** Operation with ambient thermostat (AT/OT) heat request and external probe (accessory)

Display on climatic mode



In this mode:

- The external probe (accessory) is necessary to enable the thermal unit operation. The icon **OUTSIDE** is displayed. In this case the heating setpoint can no longer be manually changed, but is calculated by the regulator.
- The Open Therm (OT) communication is enabled.
- Input 0-10V is not used.
- The Modbus communication is enabled. If a device is connected to the Modbus, the zone regulator works in priority to the ambient thermostat (AT/OT).

The heating delivery temperature is defined by a setpoint which varies according to the external temperature and the ambient temperature on the basis of a climatic curve defined by the following parameters:

Par. No.	Description
2131	Main Zone/Zone 1 mild climate external temperature compensation.
2132	Main Zone/Zone 1 ambient temperature nominal value When an OpenTherm (OT) ambient thermostat is connected to the thermal unit or to the zone control accessory, this parameter is not displayed
2119	Main Zone/Zone 1 heating setpoint at the minimum external temperature.
2120	Main Zone/Zone 1 minimum external temperature. It defines the minimum external temperature to which the maximum heating setpoint Par. 2119 must be associated.
2121	Main Zone/Zone 1 heating setpoint at the maximum external temperature (Par. 2122). It sets the minimum heating setpoint when the external temperature is equal to the value set in parameter 2122 (basic external temperature).
2122	Main Zone/Zone 1 maximum external temperature. It sets the external temperature at which the boiler setpoint must be reduced, according to the value defined in parameter 2121.
2023	Minimum heating setpoint.
2024	Maximum heating setpoint.
2125	Main Zone/Zone 1 summer/winter switching. It blocks the heating request when the external temperature is greater than this setpoint.
2130	Parallel shift of main Zone/Zone 1 climatic curve.
2134	Compensation factor of external temperature.

**Parameter 2125 (installer level)**

Between seasons, in certain days, the day external temperature may exceed the limit threshold set in parameter 2125 (summer/winter switching), in this case the heat request in heating mode is interrupted even if the ambient temperature has not yet reached the target setpoint. It is possible to increase the value of Par. 2125 preventing the request from being stopped in heating mode.

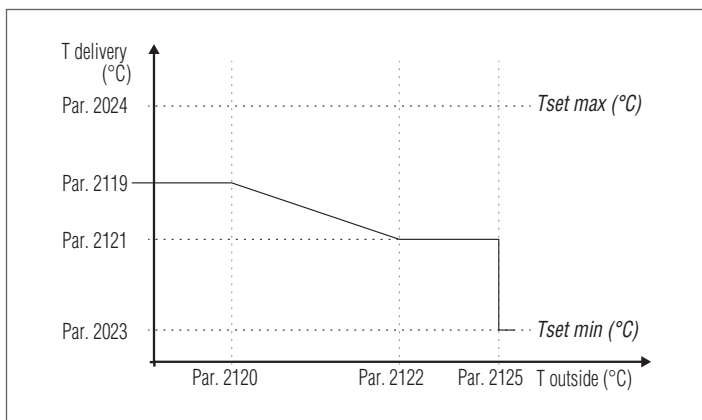

**Parameter 2131 (installer level)**

In-between seasons when the external temperature gets closer to the maximum limit set in Par. 2122, the delivery temperature calculated in climatic curve could be different from the one suitable to meet the request. This parameter performs a non-linear correction of the climatic curve to offset this difference.

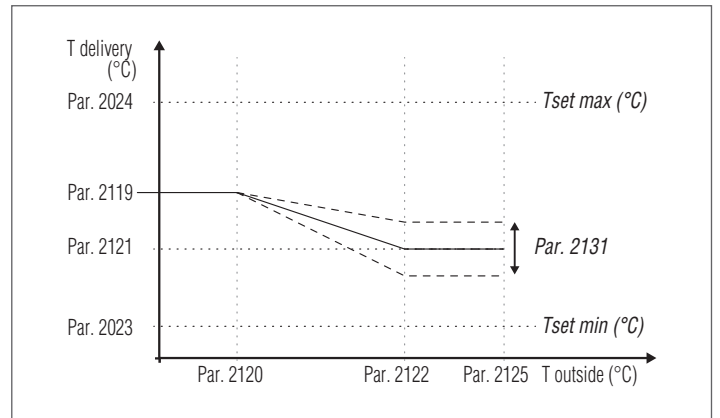

**Parameter 2132 (installer level)**

Main Zone/Zone 1 ambient temperature nominal value. This parameter defines the required ambient temperature with which the regulator calculates the heating delivery setpoint. A higher or lower required ambient temperature moves the heating curve upwards or downwards on a 45° axis. If, in heating mode 1 (Par. 2001 = 1) an OpenTherm (OT) ambient thermostat is connected to the thermal unit or to the zone control accessory, this parameter is not used since the OT ambient thermostat directly provides the regulator with the ambient temperature setpoint.

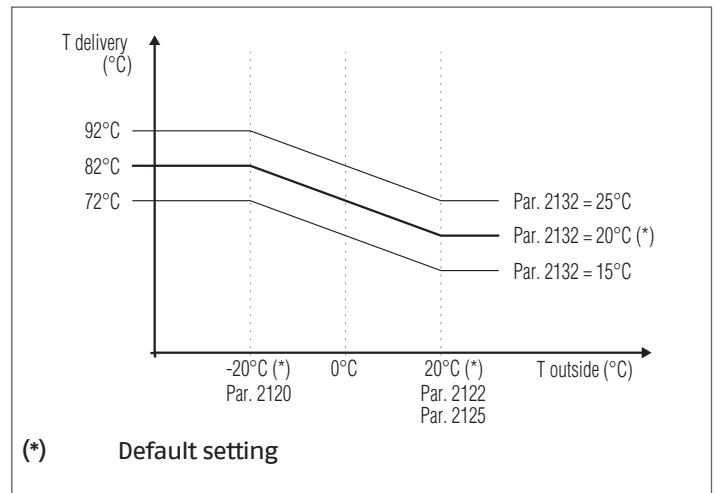

(\*) Default setting

**Parameter 2130 (user level)**

The parallel shift of the climatic curve is used to modify, in a uniform way, the delivery temperature for the whole scale of the external temperature. Changing the value of this parameter will correct the climatic curve if the ambient temperature is too high (set a negative value) or too low (set a positive value). If there is an Open Therm thermostat, this value is not considered. This parameter allows the user to directly and easily increase (positive value) or decrease (negative value) the delivery temperature to the heating system and thus the ambient temperature.

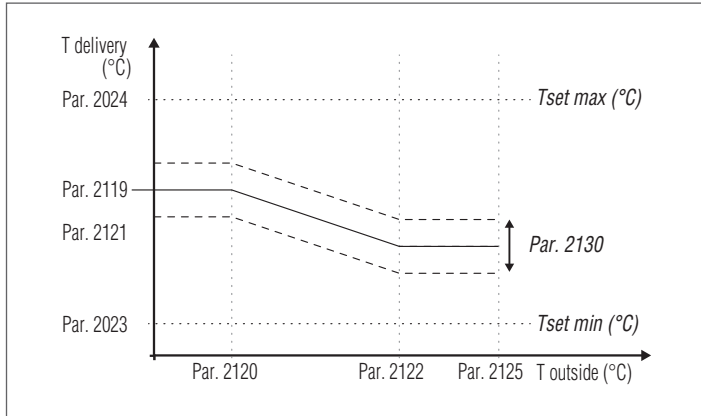

**Parameter 2134 (installer level)**

Each building has its own thermal characteristics, therefore the time needed to set up the heating system can differ even among buildings located in the same area, with the same external temperature. By using this parameter it is possible to modify the heating system reactivity adapting its response to the thermal characteristics of the building and thus optimising the environmental comfort.

Modifying the setting of this parameter (0-100%) increases or decreases the speed at which the delivery temperature changes according to the external temperature change. Setting a higher value will improve the building insulation. Example:

- 0%: The delivery temperature changes quickly when the external temperature changes.
- 100%: The delivery temperature changes slowly when the external temperature changes.

The request is enabled upon the closing of the ambient thermostat/heat request contact, provided that the external temperature does not exceed the value defined by parameter 2125. If the external temperature exceeds that set in parameter 2125, the burner stops even in the presence of a heat request.

**⚠** If the external probe (accessory) is not detected (not installed or damaged), the system makes a heat request at the maximum setpoint set (Par. 2024).

**Mode 2:** continuous operation with variable setpoint and external probe (accessory) and ambient thermostat (AT) night reduction

In this mode:

- The external probe (accessory) is necessary to enable the thermal unit operation.
- The OpenTherm (OT) communication is not enabled and any OT thermostat connected is supplied but signals a "communication error".
- Input 0-10V is not used.
- The Modbus communication is not enabled.

The equipment works with a variable setpoint defined by the climatic curve (which can be set as described in mode 1) according to the external temperature. The heat request is active regardless of the closing of the ambient thermostat/heat request contact and stops only when the external temperature is higher than that defined by the parameter 2125.

Par. No.	Description
2131	Main Zone/Zone 1 mild climate external temperature compensation.
2119	Main Zone/Zone 1 heating setpoint at the minimum external temperature.
2120	Main Zone/Zone 1 minimum external temperature. It defines the minimum external temperature to which the maximum heating setpoint Par. 2119 must be associated.
2121	Main Zone/Zone 1 heating setpoint at the maximum external temperature (Par. 2122). It sets the minimum heating setpoint when the external temperature is equal to the value set in parameter 2122 (basic external temperature).
2122	Main Zone/Zone 1 maximum external temperature. It sets the external temperature at which the boiler setpoint must be reduced, according to the value defined in parameter 2121.
2023	Minimum heating setpoint.
2024	Maximum heating setpoint.
2125	Main Zone/Zone 1 summer/winter switching. It blocks the heating request when the external temperature is greater than this setpoint.
2130	Parallel shift of main Zone/Zone 1 climatic curve.
2133	Main Zone/Zone 1 setpoint night reduction in heating mode Par. 2001 = 2 or 3. It defines by how many degrees the heating setpoint will be reduced at the opening of the ambient thermostat (AT) contact. The reduction of the delivery temperature affects all the active heating zones and it can be used when the AT terminal of every zone regulator is jumpered.
2134	Compensation factor of external temperature.

The parameter 2133 defines by how many degrees the setpoint decreases (night reduction) when the ambient thermostat/heat request contact opens.

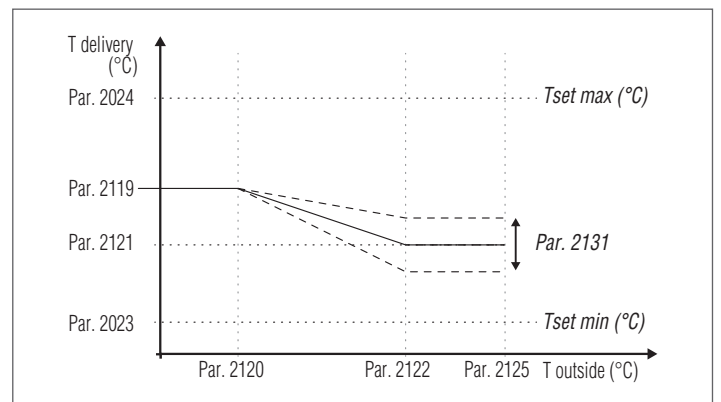

**⚠** If the external probe (accessory) is not detected (not installed or damaged), the system makes a heat request at the maximum setpoint set on the climatic curve.

**Mode 3:** continuous operation with fixed setpoint and night reduction with ambient thermostat (AT)

In this mode:

- External probe is not required.
- The OpenTherm (OT) communication is not enabled and any OT thermostat connected is supplied but signals a "communication error".
- Input 0-10V is not used.
- The Modbus communication is not enabled.

The fixed setpoint adjustment procedure is the same of mode 0. The only difference is that the request is always active and the setpoint is decreased (night reduction) by the value defined by the parameter 2133 upon the opening of the ambient thermostat/heat request contact.

Par. No.	Description
2103	Main Zone/Zone 1 setpoint in heating mode Par. 2001=0 and 3. The thermal unit adjustment determines the boiler setpoint in heating mode, using the highest value among the requests of all the active zones (Par. 1101, 1201, 1301). If Zone 1 is set as mixed, the value set in parameter 1112 will be used as setpoint.
2023	Minimum heating setpoint.
2024	Maximum heating setpoint.
2133	Main Zone/Zone 1 setpoint night reduction in heating mode Par. 2001=2 or 3. It defines by how many degrees the heating setpoint will be reduced at the opening of the ambient thermostat (AT) contact. The reduction of the delivery temperature affects all the active heating zones and it can be used when the AT terminal of every zone regulator is jumpered.

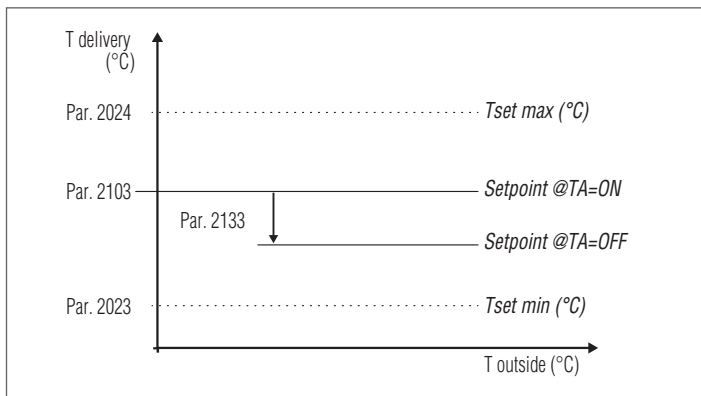

**Mode 4:** operation with variable setpoint according to the value of the input signal 0-10V

In this mode:

- External probe is not required.
- The OpenTherm (OT) communication is not enabled and any OT thermostat connected is supplied but signals a "communication error".
- The Modbus communication is not enabled. If a device is connected to the Modbus, the values on the remote device are not updated.

The parameters regulating such temperature are:

Par. No.	Description
2023	Minimum heating setpoint.
2024	Maximum heating setpoint.
2025	It defines the delivery temperature minimum value in heating mode (Par. 2001 = 4).
2026	It defines the delivery temperature maximum value in heating mode (Par. 2001 = 4).

The operation set-point is adjusted on the basis of the following curve:

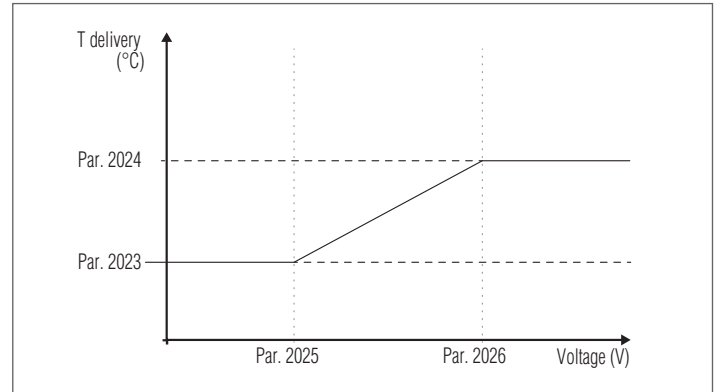

### 3.2.6 Setting the domestic hot water parameters

The thermoregulation on the thermal unit allows having many configurations for the management of the domestic hot water production.

#### Self-acknowledgement of Probe or Heater Thermostat

At every restoration of the power supply the connected sensor is checked automatically.

If a temperature probe is identified, the setpoint for the domestic hot water is defined by parameter 2047 (DHW setpoint with heater).

If a temperature probe is not identified, the controller hypothesises the presence of a thermostat that should provide only an open / closed signal. In this case, a Setpoint is set on the primary circuit defined by parameter Par. 2041 (Primary setpoint for heater with thermostat), regardless of the setpoint set in parameter 2047.

**NOTE:** Pay attention to the Error 60 cases due to heater probe reading errors

#### Domestic hot water request with heater probe

When the temperature detected by the heater probe drops below the DHW setpoint value (Par. 2047) minus the hysteresis value (Par. 2036) the regulator detects a domestic hot water request and activates the circulator switching the 3-way diverting valve on domestic circuit.

In this case, the circulator works with a setpoint (Par. 2049).

The burner turns on when the temperature detected by the delivery probe drops below the DHW setpoint value (Par. 2047) plus the value defined in parameter 2038 minus 3°C (hysteresis), this value corresponds by default to 69°C.

The request is met when the temperature detected by the heater probe exceeds the DHW setpoint value (Par. 2047) plus the hysteresis value (Par. 2037).

The circulator carries on working for the post-circulation time (Par. 2044).

The burner turns off when the temperature detected by the delivery probe exceeds the DHW setpoint value (Par. 2047) plus the value defined in parameter 2038 plus 3°C (hysteresis), this value corresponds by default to 75°C.

### Domestic hot water request with heater thermostat

When the temperature of the heater thermostat drops below the DHW setpoint value (Par. 2041) minus the hysteresis value (Par. 2036) the regulator detects a domestic hot water request and activates the circulator switching the 3-way diverting valve on domestic circuit.

In this case, the circulator works with a setpoint (Par. 2049). The burner turns on when the temperature detected by the delivery probe drops below the DHW setpoint value (Par. 2041) plus the value defined in parameter 2038 minus 3°C (hysteresis), this value corresponds by default to 87°C.

The request is met when the temperature detected by the heater probe exceeds the DHW setpoint value (Par. 2041) plus the hysteresis value (Par. 2037).

The circulator carries on working for the post-circulation time (Par. 2044).

The burner turns off when the temperature detected by the delivery probe exceeds the DHW setpoint value (Par. 2041) plus the value defined in parameter 2038 plus 3°C (hysteresis), this value corresponds by default to 93°C.

### 3.2.7 Heat request priority

#### Priority setting

The parameter 2042 defines the priority between domestic and heating circuit.

Four modes are envisaged:

- 0:** Time priority between the two circuits. In case of simultaneous request, the first priority is assigned to the domestic circuit for a time period defined in parameter 2043. Once this time period has elapsed, the priority is assigned to the heating circuit (for the same time period) and so on, alternately, until the request of one or both circuits stops;
- 1:** Priority assigned to the heating circuit;
- 2:** Priority assigned to the domestic circuit (factory setting).
- 3:** Parallel. Both circuits operate simultaneously, with the proviso that the delivery temperature requested by the DHW circuit must be lower than or equal to the setpoint requested by the heating circuit. When the temperature requested by the DHW circuit is higher than the heating setpoint, the heating circuit pump is turned off and priority is switched to the DHW circuit.

### 3.2.8 Special functions

When a special function is active, a specific message is shown on the display of the device control interface.

#### Pump activation protection during a Domestic Water request

If during a domestic water request the delivery temperature of the burner is lower than that of the heater the pump will not be activated.

#### Frost protection

The anti-freeze protection function protects the system against freezing.

When the anti-freeze function is active, the message "AFro" is displayed.

The intervention modes are the following:

- **Boiler anti-freeze protection (Par. 2074):** If the temperature of the delivery probe of the device drops below 5°C the burner turns on and stays on until the delivery temperature exceeds 10°C (with the external probe connected the protection activates only with external temperature values < 10°C).
- **Heating circuit anti-freeze protection (Par. 2075):** If the burner stays off for 6 consecutive hours the circulator of the device will activate for 5 minutes. If the temperature of the delivery probe of the device drops below 5°C the burner turns on and stays on until the delivery temperature exceeds 10°C (with the external probe connected the protection activates only with external temperature values < 10°C).
- **Domestic circuit heater anti-freeze protection (Par. 2076):** If the temperature of the heater probe drops below 5°C the burner turns on and the circulator and 3-way diverting valve will activate. The burner stays on until the temperature of the heater probe exceeds 10°C and the circulator carries on working for the post-circulation time (Par. 2044). With the external probe connected the protection activates only with the external temperature values < 10°C.

#### Venting (Par. 2090)

The function is automatically enabled at the first start-up and at each reset of the power supply.

When the function is active, the message "Air" is displayed.

During the venting, the circulator is enabled, so that the air which may be present inside the system circuit can exit through the automatic drain valve of the device.

The status of the light guide changes to flashing green.

During venting it is possible to deactivate the function by setting the parameter 2090 = 0

In the event of a low pressure error (40 and 41) or error of the pressure transducer (42), the bleed cycle is interrupted.

**Protection against temperatures that are too high**

This function prevents a possible safety thermostat triggering. If the boiler temperature exceeds the value set in this parameter, the burner turns off and the circulator continues its operation to discharge the excessive heat (post-circulation).

**Circulator and 3-way valve activation every 24 hours**

Every 24 hours the circulator and 3-way diverting valve are activated for 30 seconds (only in heating mode 0,1,4). This function prevents the circulator and valve from getting stuck in a determined position.

**Test mode (chimney sweeper)**

When this function is enabled (Par. 200 = 1) the equipment works at maximum power and the 3-way diverting valve switches on the domestic circuit for a time (which cannot be changed) of 15 minutes, then it goes back to its normal operation.

It is possible to interrupt at any moment the operation in test mode (Par. 200 = 0). If the delivery probe of the device reaches 82°C (maximum operating temperature) the burner turns off.

When using this function, it is recommended to leave one of the domestic hot water valves open, in order to discharge excessive heat.

 Attention! Hot water runs through the system. Danger of scalding with hot water!

**Anti-legionella function (Par. 2080) – With Heater Probe only**

The function is automatically enabled when the heater sensor is connected, at each power supply reset or daily, if necessary (factory setting Par. 2080 = 2).

When the function is on, the message “ALE9” is shown next to the storage tank temperature.

The function increases the water temperature inside the heater up to 60°C and keeps it for 30 minutes.

Once this time has elapsed, the control box normal operation is restored.

**3.2.9 Flow meter parameters configuration (accessory)**

Choose the flow meter to be installed according to the ΔT of operation of the thermal module.

	INSIEME EVO COND		
	45 LN	55 LN	70 LN
ΔT = 20°C	DN 25	DN 25	DN 25
ΔT = 15°C	DN 25	DN 25	DN 25
ΔT = 10°C	DN 25	DN 25	DN 25

After installing the flow meter accessory following the instructions provided, set the following parameters:

Par. No.	Description	Parameter setting
2027	Progr.ble inp. 2	1 = Heating flow meter

Par. No.	DN 15	DN 20	DN 25	UM
2019	10 (*)	10 (*)	10 (*)	l/min
2020	3	3	3	

(\*) Recommended value

Par. No.	Description
1062	Displays the flow meter flow rate Display active only with Par. 2027 = 1

**3.2.10 Flow switch configuration**

After connecting the flow switch to terminals 28-29 of terminal board M01, set parameter 2027 = 2 (heating flow switch).

### 3.2.11 Ignition failure

If an ignition or operating anomaly occurs, the thermal unit display will show a text message (small digit) and a number (large digit), which vary according to the anomaly detected.

For a detailed description, see the error list.

There are 3 error levels:

- Permanent (Loc)
- Temporary (Err)
- Alerts (AttE)

The section with the large digit will display the error number and, according to the error / alert, a message which will cyclically blink together with the number.

For a detailed description, see the error list.

#### Permanent Error

The text "Loc" is displayed together with the permanent error number. The icon  indicates that the burner is disabled. The equipment must be manually reset by keeping the key "ENETER/RESET" pressed.



#### Temporary Error

The text "Err" is displayed together with the temporary error number.

The icon  indicates that the burner is disabled.

The lock-out error must be solved.

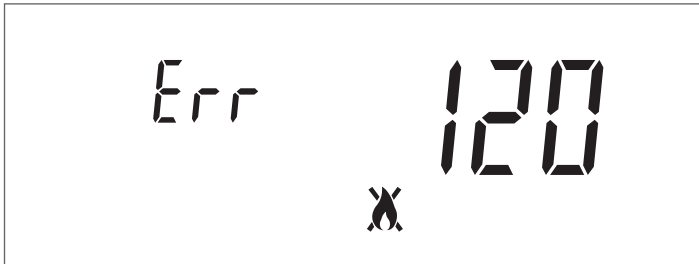

#### Warnings

The text "AttE" is displayed together with the alert number.

The equipment is not locked out, but its functions may be limited (according to the alert).



### 3.3 Checks during and after initial start-up

Once the boiler has started up, make sure that it shuts down and re-starts properly when:

- By changing the set temperature;
- By moving the main switch from (I) to (O) and vice versa;

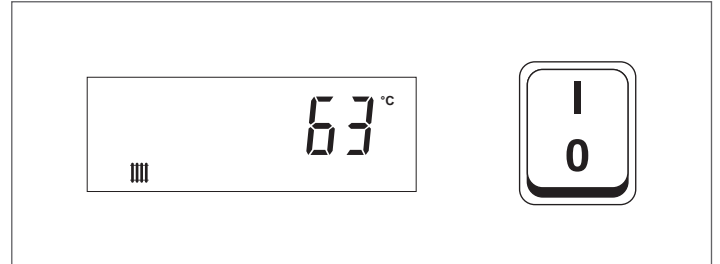

- The room thermostat or timer setting is changed;

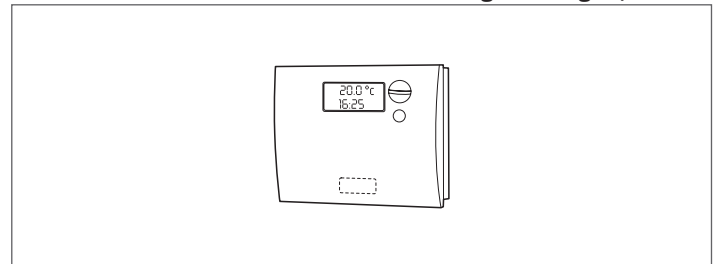

- Check that the pump turns freely as deposits and/or residue may prevent this from happening, especially after long periods of inactivity;

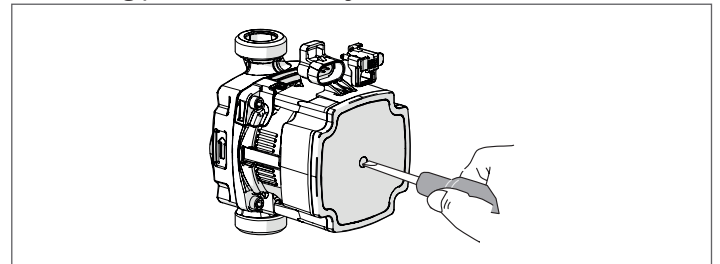

- Check that the thermal unit has come to a complete stop by setting the main switch of the equipment and the main switch of the system to "off".

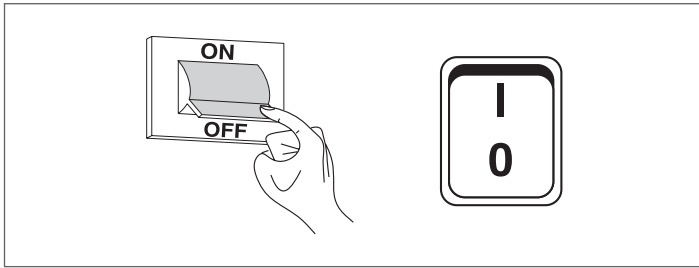

If all the requirements are fulfilled, restart the thermal unit and carry out the analysis of the combustion products by enabling the test mode (Par. 200 = 1). During the test mode (chimney sweeper), the equipment works at the maximum power for a time period of 15 minutes, then it is automatically disabled. Once the analysis of the combustion products is complete, disable the function (Par. 200 = 0).

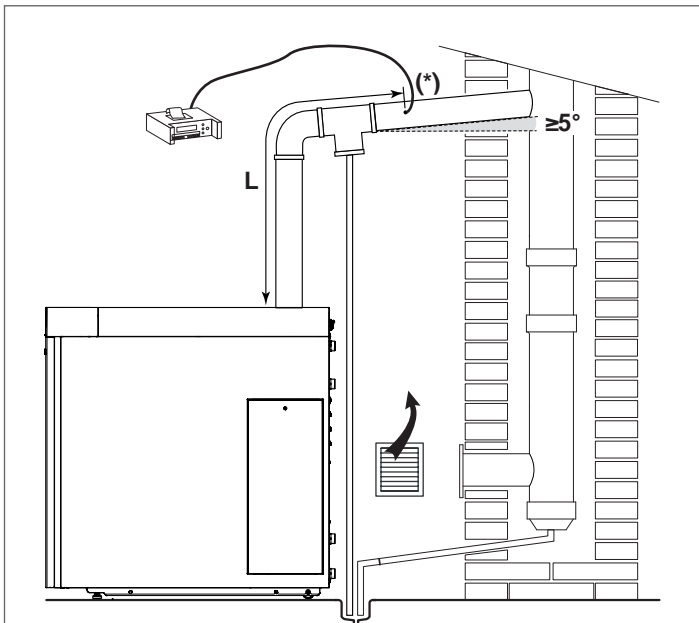

(\*) The sampling hole for flue gas analysis must be made on the straight section of the discharge duct, sufficiently far from curves and elbows. For the hole size and its correct positioning on the discharge duct (minimum or maximum distance from the equipment outlet to be observed), refer to the regulations in force.

**⚠** Always plug the sampling hole after analysing the flue gases.

### 3.4 Single-stage burner

Used in the model: **INSIEME EVO COND 45 LN**

#### 3.4.1 Burner control and adjustment

##### ADJUSTING PUMP PRESSURE

Turn the adjuster screw (1) to achieve the pressure setting specified in the table.

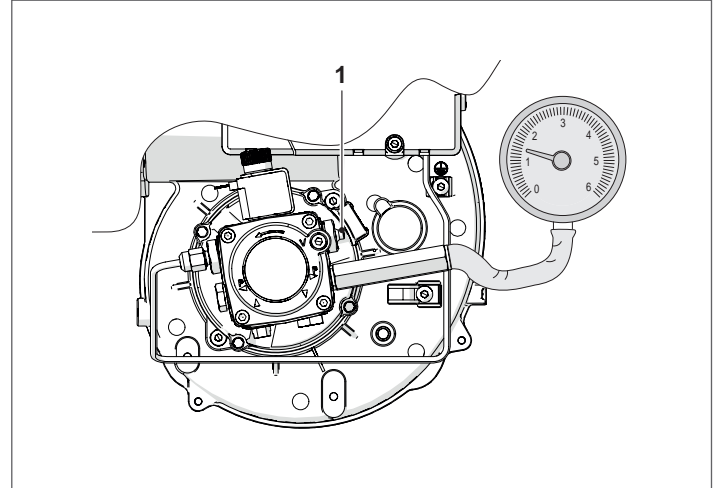

	<b>INSIEME EVO COND 45 LN (*)</b>
Adjusting pump pressure	12,0 bar

(\*) Burner with oil heater

##### ADJUSTING THE AIR DAMPER

The air damper can be adjusted without removing the burner cover.

- Use an Allen key to turn the adjuster screw (1) to achieve the required setting on the graduated scale (2)

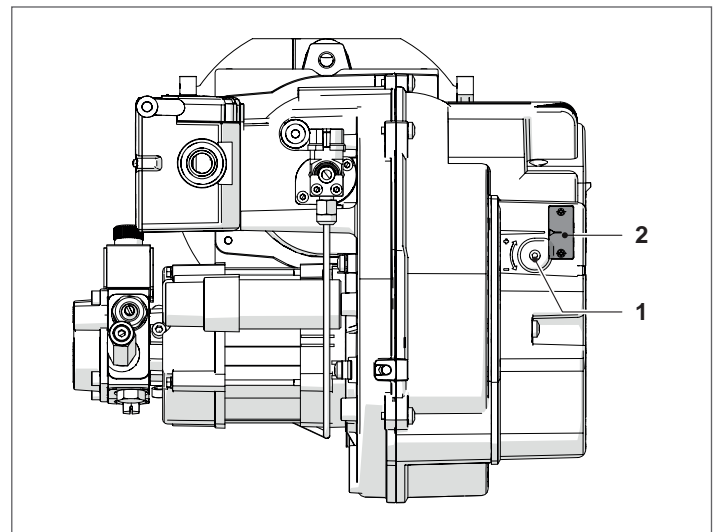

	<b>INSIEME EVO COND 45 LN (*)</b>
Adjusting the air damper	2,25

(\*) Burner with oil heater

### 3.4.2 Burner functioning and programming

#### Normal functioning

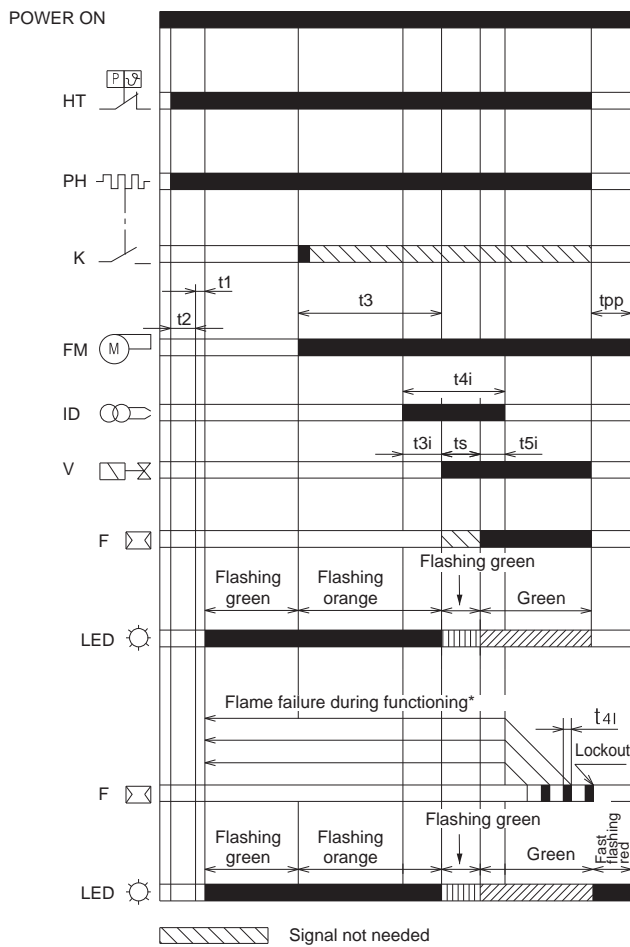

- HT** Heat request
  - PH** Pre-heater
  - K** Thermostat for enabling start-up after pre-heating
  - FM** Fan motor
  - ID** Ignition electrode
  - V** Fuel oil valve
  - F** Flame detector
  - LED** Colour of button LED
  - t1** Wait time
  - t2** Initialisation time for checking
  - t3** Pre-purging time
  - t3i** Pre-ignition time
  - t3l** Pre-ignition time
  - t4i** Total ignition time
  - t4l** Reaction time to achieve safety lockout due to lack of flame
  - t5i** Post-ignition time
  - ts** Safety time
  - tpp** Post-purging time
- (\*) Only 3 consecutive ignitions are allowed

	DESCRIZIONE	VALUE
t0	Standby: the burner waits for a heat request	-
t1	Standby time for an input signal: reaction time, control box remains in waiting mode for t1	≤ 1 sec
t2	Initialisation verification time: time following startup of main power supply	3,5 sec
t2l	Checks extraneous light or parasite flame during t2: waiting mode for t2l, then lockout: the motor does not start	25 sec
t2p	Max. light oil preheating time: waiting state for t2p, then the lockout takes place	max 600 (*)
t3	Pre-purging time: the fan motor runs then the fuel oil valve opens	15 sec
t3l	Checks extraneous light or parasite flame during pre-purging: control box goes into lockout at the end of t3l	25 sec
t3i	Spark pre-ignition time	2 sec
ts	Safety time	5 sec
t4i	Total spark ignition time	10 sec
t4l	Valve deactivation reaction time following flame failure	≤ 1 sec
t5i	Spark post-ignition time	3 sec
-	Minimum time to reset the control box using reset button	0,4 sec
tr	Cycle repetition: max. 3 repeats of the complete ignition sequence if flame fails during normal functioning; the controller enters lockout if no flame is detected after the last ignition attempt	3 repeats
tpp	Post-purging time: additional purging time at the end of the heat request. It can be interrupted by a new heat request	60 sec

Times are expressed in seconds.  
 (\*) independent of burner controller

Lockout caused by ignition failure

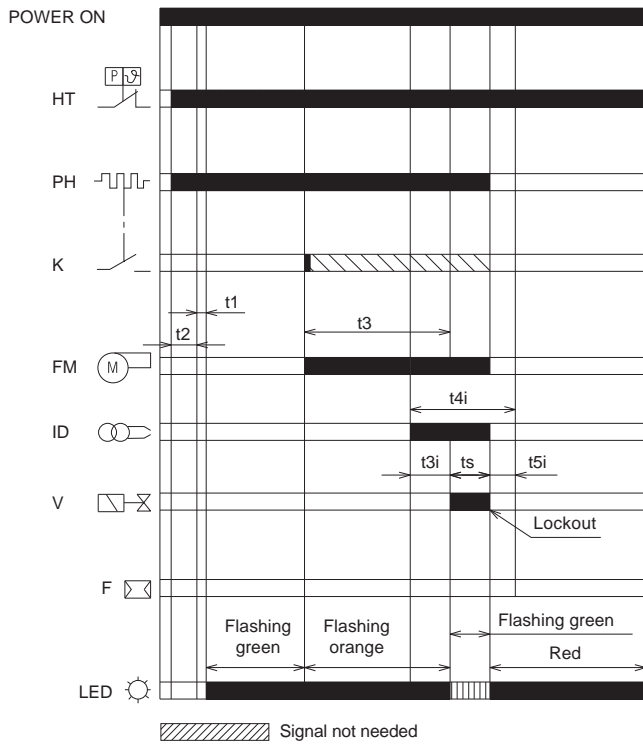

- HT Heat request
- PH Pre-heater
- K Thermostat for enabling start-up after pre-heating
- FM Fan motor
- ID Ignition electrode
- V Fuel oil valve
- F Flame detector
- LED Colour of button LED
- t1 Wait time
- t2 Initialisation time for checking
- t3 Pre-purging time
- t3i Pre-ignition time
- t4i Total ignition time
- t4l Reaction time to achieve safety lockout due to lack of flame
- t5i Post-ignition time
- ts Safety time
- tpp Post-purging time

(\*) Only 3 consecutive ignitions are allowed

	DESCRIZIONE	VALUE
t0	Standby: the burner waits for a heat request	-
t1	Standby time for an input signal: reaction time, control box remains in waiting mode for t1	≤ 1 sec
t2	Initialisation verification time: time following startup of main power supply	3,5 sec
t2l	Checks extraneous light or parasite flame during t2: waiting mode for t2l, then lockout: the motor does not start	25 sec
t2p	Max. light oil preheating time: waiting state for t2p, then the lockout takes place	max 600 (*)
t3	Pre-purging time: the fan motor runs then the fuel oil valve opens	15 sec
t3l	Checks extraneous light or parasite flame during pre-purging: control box goes into lockout at the end of t3l	25 sec
t3i	Spark pre-ignition time	2 sec
ts	Safety time	5 sec
t4i	Total spark ignition time	10 sec
t4l	Valve deactivation reaction time following flame failure	≤ 1 sec
t5i	Spark post-ignition time	3 sec
-	Minimum time to reset the control box using reset button	0,4 sec
tr	Cycle repetition: max. 3 repeats of the complete ignition sequence if flame fails during normal functioning; the controller enters lockout if no flame is detected after the last ignition attempt	3 repeats
tpp	Post-purging time: additional purging time at the end of the heat request. It can be interrupted by a new heat request	60 sec

Lockout caused by extraneous light during pre-purging

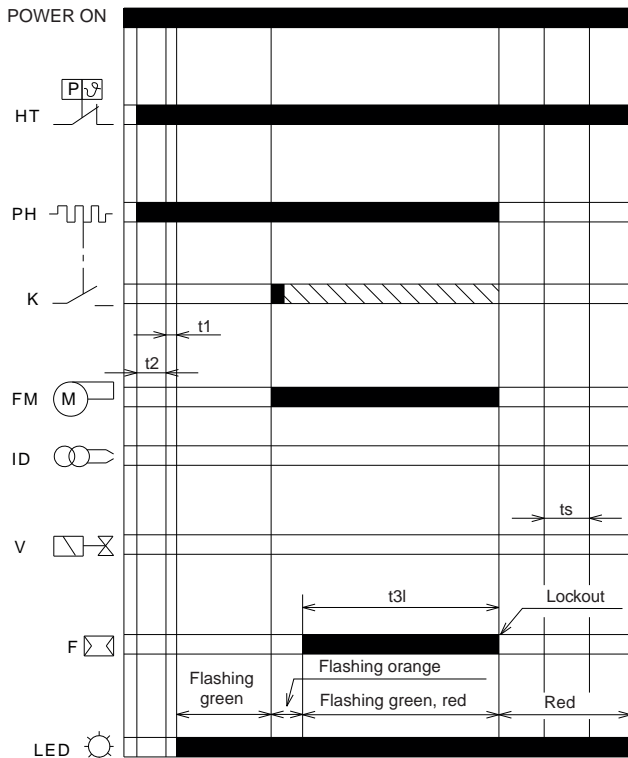

Times are expressed in seconds.

(\*) independent of burner controller

Functioning status display

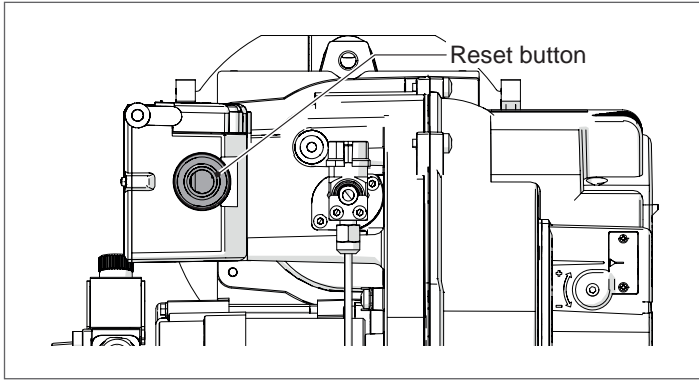

Functioning status	Reset button LED colour	Flash time	Seconds	
			ON	OFF
OFF	○ OFF	-	-	-
Pre-heating time	● Flashing GREEN	Slow	0,5	2,5
Pre-ventilation	● Flashing ORANGE	Slow	0,5	0,5
Safety time	● Flashing GREEN	Slow	0,5	0,5
Normal functioning position	● GREEN	-	Steady ON	



Fault diagnosis - lockouts

Fault description	Reset button LED colour	Flash time	Seconds	
			ON	OFF
Extraneous light or false flame signal	●● GREEN, RED alternate flashing	Slow	0,5	0,5
Power supply frequency error	● ORANGE	-	Steady ON	
Internal voltage error	●● ORANGE, GREEN alternate flashing	Fast	0,2	0,2
Reset / remote reset button error	●● GREEN, RED alternate flashing	Fast	0,2	0,2
Lockout for flame failure after Ts	● RED	-	Steady ON	
Lockout for extraneous light or false flame signal	● RED flashing	Slow	0,5	0,5
Lockout for maximum number of cycle repetitions (flame failure during functioning)	● RED flashing	Fast	0,2	0,2
Lockout for exceeding maximum pre-heating time	● RED flashing	Slow	0,5	2,5
Lockout for fan motor fault	●● RED, ORANGE flashing	Reversed	2,5	0,5
Lockout for fuel oil valve fault	●● RED, GREEN flashing	Reversed	2,5	0,5
Lockout for EEPROM fault	●● ORANGE, GREEN alternate flashing	Slow	0,5	0,5

**Lockout types**

Whenever a lockout occurs, the control box shows the reasons for the fault (and the reasons can be identified by the reset button colour).

Description of lockout	Lockout time	Led colour	Probable cause
Presence of extraneous light during standby	After 25 seconds	● RED flashing	presence of a false flame after heat request.
Pre-heating not finished	After 600 seconds	● RED flashing	light oil heater resistance fault starter switch or thermostat fault
Detection of extraneous light during pre-purging or pre-heating	After 25 seconds	● RED flashing	presence of false flame signal during pre-purging or preheating
Detection of extraneous light during post-purging	After 25 seconds	● RED flashing	presence of false flame signal during post-purging
Flame not detected by end of safety time	5 seconds after the activation of the fuel oil valve	● RED Steady ON	flame detector faulty or dirty light oil valve faulty or dirty faulty ignition transformer badly regulated burner fuel oil not present
Flame failure during functioning	After 3 ignition attempts	● RED	burner not calibrated correctly light oil valve faulty or dirty flame detector faulty or dirty
Fan motor fault	Immediate (during pre-purging)	●○ RED, ORANGE flashing	faulty fan motor fan motor not connected
Fault with the light oil valve control circuit	Immediate (during pre-purging)	●○ RED, GREEN flashing	light oil valve faulty light oil valve control circuit faulty
EEPROM fault	Immediate (during pre-purging)	○● ORANGE, GREEN alternate flashing	faulty internal memory

-  To reset the control box after visual diagnostics have been displayed, you must press the reset button.
-  In the event the burner stops, in order to prevent any damage to the installation, do not unblock the burner more than twice in a row. If the burner locks out for a third time, contact the Technical Assistance Service.
-  In the event there are further lockouts or faults with the burner, the maintenance interventions must only be carried out by qualified, authorised personnel, in accordance with the contents of this manual and in compliance with the standards and regulations of current laws.

## MAIN BURNER FUNCTIONS

### FUEL PRE-HEATING FUNCTION

The burner has an oil pre-heating function. When the boiler thermostat requests a burner start-up, the burner waits for the contacts of pre-heating thermostat (K), located at the oil nozzle holder, to close.

If the startup or pre-heating thermostat does not close after 600 seconds, the burner controller locks out.

If the flame goes out during operation, the burner carries out the recycle again if the contact of the start-up thermostat (or the pre-heating one, K) is closed.

If the flame goes out during normal functioning and the contacts of the startup or pre-heating thermostat (K) are open, the burner remains in the purge phase for the duration of post-purging time (if programmed), then purging stops and the burner waits for the contacts of the startup or pre-heating thermostat (K) to close before restarting pre-purging time.

### SHUTDOWN TEST

If the reset button is pressed during operations for more than 5 seconds and less than 10 seconds, the burner switches off, the light oil valve closes, the flame goes out and the start-up sequence restarts.

If the test is enabled, the number of repetitions of the start sequence (see "CYCLING AND THE SEQUENCE REPETITION LIMIT" on page 65) and the number of possible restarts (see "PROTECTION RESET" on page 65), are restored.

### CONTROLLED SHUTDOWN AND RESTART

After 24 hours of continuous functioning, the controller initiates a controlled shutdown followed by a re-start to ensure that the flame detector is not faulty.

You can reduce reduced shutdown and restart time to 1 hour (see "Programming Mode").

### CYCLING AND THE SEQUENCE REPETITION LIMIT

The burner controller has a cycling function. This means that the controller will repeat the complete startup sequence up to 3 times if the flame goes out during normal functioning.

If the flame fails 4 times during operations, this will cause the burner to lock out.

If there is a new heat request during the recycle, the 3 attempts are reset at the next request of the limit thermostat (TL).

#### NOTE:

After 510 seconds of continuous operation, a further attempt is made, if necessary.

When the power supply is disconnected, when there is a new heat request, all possible restart attempts are reset to 3 (maximum 3).

### EXTRANEIOUS LIGHT OR FALSE FLAME SIGNAL

The presence of a parasite flame or extraneous light can be detected in the stand-by state when the burner is stopped and waiting for a heat request or during preheating.

If the presence of a flame or extraneous light is detected also in the "t2" stage, the motor does not start until the flame signal has disappeared or until lockout has been reached.

If extraneous light or a false flame signal is detected when the fan motor is running during pre-purging, the burner stays in purge mode until the light or flame signal stops. If this does not occur within 25 seconds, the burner locks out.

If, during pre-purging, a parasite flame or extraneous light is detected, the pre-purging time of 15 seconds is reset to zero and the time for checking the presence of the parasite flame or extraneous light starts (the motor continues to ventilate).

The function is cumulative and can be performed up to 2 times. If the parasite flame or extraneous light disappears before 25 seconds, the pre-purging time starts; if the parasite flame or extraneous light occurs again, the pre-purging time is reset to zero and the 25-second count for checking the presence of the parasite flame or extraneous light restarts.

The burner also locks out if extraneous light or a false flame signal is detected three times.

If, during the recycle due to flame loss while operating and the consequent repetition of the start-up sequence, the parasite flame or the extraneous light is detected, the 25 seconds control countdown starts.

The fault is indicated by the flashing of the LED (see paragraph "Fault diagnosis - lockouts" on page 63).

### PRE- AND POST-IGNITION PHASE

During pre-ignition, the ignition electrode switches on 2 seconds before the fuel oil valve opens.

During post-ignition, the ignition electrode switches off 3 seconds after the end of safety time.

Ignition remains active throughout safety time.



In the event of continuous recycling or heat requests that are close together, the maximum allowed number of cycle repetitions for the ignition transformer is one every minute.

### PROTECTION RESET

The burner can be reset only 5 times consecutively, then power supply has to be disconnected for a new 5 reset possibilities.

The burner can only be reset if power supply is applied to the control box.

### RESET / REMOTE RESET BUTTON ERROR

In any state (ON/OFF thermostat), if the release button or the remote release button fails or remains pressed for more than 60 seconds, the fault is indicated by the flashing led (see paragraph "Fault diagnosis - lockouts" on page 63) as long as it is present.

- This fault is only displayed and the led stops blinking when the fault disappears.
- If the fault is detected during pre-purging, preheating or safety time, the burner does not stop and the start-up sequence continues.
- If the fault is detected during a lockout, the fault is not signalled and the burner cannot be reset.
- If the fault is detected during operation, the burner does not stop.

**POWER SUPPLY FREQUENCY ERROR**

The control box automatically detects the value of the frequency of the main supply in the range of 50 – 60 Hz, in both cases working times are verified. The fault is indicated by the flashing of the LED (see paragraph "Fault diagnosis – lockouts" on page 63).

- If an error is detected before a heat request is made, the burner does not start up and the error is signalled.
- If an error is detected during pre-purging, the burner remains in purge mode and the error is signalled.
- If no error is detected during normal functioning, the burner continues to function normally.
- The burner starts up as soon as the error disappears.

**INTERNAL VOLTAGE ERROR**

The control box automatically detects if the internal voltage works correctly. The fault is indicated by the flashing of the LED (see paragraph "Fault diagnosis – lockouts" on page 63).

- If an error is detected during initialisation, the burner does not start up.
- If an error is detected after a lockout, the burner will not start up.
- If an error is detected after a shutdown test, the burner will not start up.
- If no error is detected during normal functioning, the burner continues to function normally.
- The burner starts up as soon as the error disappears.

**FAN MOTOR CONTROL**

The control box automatically detects the presence of the fan motor and, if it is disconnected, it performs a lockout. The lockout is indicated by the flashing of the LED (see paragraph "Fault diagnosis – lockouts" on page 63).

**CHECKING THE LIGHT OIL VALVE CONTROL ELECTRONIC CIRCUIT**

The control box detects the presence of an internal light oil fault, the fault is indicated by the blinking led. (see paragraph "Fault diagnosis – lockouts" on page 63):

- If the anomaly is detected during the initialisation, the burner goes into lockout.
- If the anomaly is detected during the pre-purging, the burner goes into lockout.
- During a recycling, if the fault is detected, the burner does not start and goes into lockout.
- If no error is detected during normal functioning, the burner continues to function normally.

The fault is not detected if the burner is in lockout.

**EEPROM CHECK**

The burner controller automatically checks for errors in the microcontroller EEPROM and enters lockout if an error is detected. The lockout is indicated by the flashing of the LED (see paragraph "Fault diagnosis – lockouts" on page 63).

**DEACTIVATION OF AUTOMATIC PRE-HEATING**

The automatic pre-heating functioning can be deactivated by pressing the reset or remote reset button. Pre-heating remains de-activated until:

- a lockout occurs;
- mains power fails or is switched off;
- the boiler shuts down for a controlled shutdown and re-start.

Pre-heating de-activation sequence	Colour of button LED
Only de-activate the pre-heating if no lockout or errors are present	-
Deactivate the pre-heating by means of the reset or remote reset button.	-
Switch on the burner and simultaneously hold down the reset or remote reset button for 3 seconds.	RED
Release the reset or remote reset button within 3 seconds.	OFF
The burner will de-activate pre-heating only if the reset or remote reset button is released within 3 seconds.	-

The deactivation of the automatic pre-heating function is not lost if the switching off test function is active or if the heat request thermostat opens.

**POST-PURGING**

The post-purging function keeps the fan running for a set time after the burner shuts down provided there is no new heat request.

When the contacts of the heat request thermostat open, the burner controller shuts down the flame and shuts off the oil supply.

Post-purging does not occur:

- after a lockout;
- if a heat request is cancelled during pre-purging.

Post-purging occurs:

- if a heat request is cancelled during safety time;
- if a heat request is cancelled during normal functioning.

**NOTE**

If extraneous light or a false flame signal is detected during post-purging, the burner locks out after 25 seconds.

If a new heat request is detected during post-purging, post-purging time is reset, the fan motor stops and a new burner ignition cycle is initiated.

**PROGRAMMING MENU**

**General**

The programming menu can be accessed via the integrated reset button during OPERATION and in STAND-BY.

If in the menu page the reset button is not pressed within 10 seconds, the page will be automatically quitted and a green led will start flashing for the time set.

If the number of presses on the reset button exceeds the maximum allowable, the value that stays in memory will be the maximum one.

If the reset button is pressed for more than 60 seconds, a button error will be displayed and the control box will restart.

Menu access block diagram

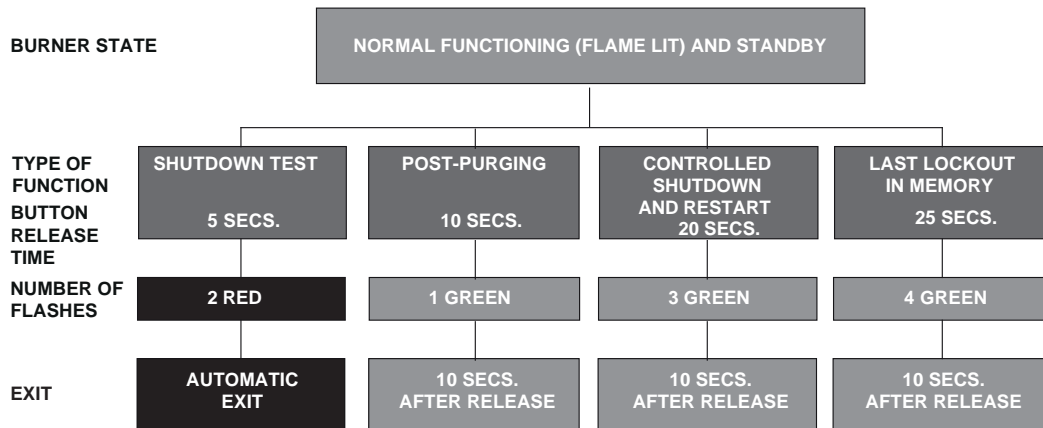

Function	Button release time	No. of LED flashes for menu page	No. of times reset button is pressed	No. of (green) LED flashes	Exit menu
Shutdown test	$5s \leq t < 10s$	2 blinks RED	/none	/none	Automatic when flashing finishes
Post-purging	$10s \leq t < 15s$	1 flash GREEN	1 = 10 secs. 2 = 20 secs. 3 = 30 secs. 4 = 60 secs. (default) 5 = 120 secs. 6 = 0 secs. (disabled)	1 flash 2 flashes 3 flashes 4 flashes 5 flashes 6 flashes	10 seconds after button is released
Controlled shutdown and restart	$20s \leq t < 25s$	3 blinks GREEN	1 = 0 disabled 2 = 1 hour 3 = 24 hours (default)	1 flash 2 flashes 3 flashes	10 seconds after button is released
Last lockout in memory	$25s \leq t < 30s$	4 blinks GREEN	/none	Display of the type of lockout, (see paragraph "Fault diagnosis - lockouts" on page 63)	10 seconds after button is released

**SHUTDOWN TEST**Shutdown test sequence:

- Programming allowed in OPERATING mode and in STANDBY.
- Press button for 5 sec.  $\leq t < 10$  sec.
- RED led Blinking 2 times (0.2s. ON; 0.2s. OFF).
- Release the button.
- The burner shuts down and restarts.

The burner shuts down then restarts automatically. Each shutdown test resets (zeroes) the ignition cycle count. No LEDs flash when you exit the shutdown test menu.

**POST-PURGING**

Post-purging time can be set to a maximum of **120 seconds**. To set post-purging time, proceed as follows.

Post-purging programming sequence:

- programming permitted in NORMAL FUNCTIONING and STANDBY mode;
- Press and hold the burner reset button for between 10 and 15 seconds;
- The GREEN LED flashes 1 once;
- Release the button;
- The GREEN LED stays OFF;
- Press the button from 1 to 5 times (\*);
- The GREEN LED flashes ON-OFF at each press and release;
- After 10 seconds, the GREEN LED flashes for the programmed number of times (0.5s ON; 0.5s OFF).

Post-purging de-activation sequence:

- resetting permitted in NORMAL FUNCTIONING and STANDBY mode;
- Press and hold the burner reset button for between 10 and 15 seconds;
- The GREEN LED flashes 1 once;
- Release the button;
- The GREEN LED stays OFF;
- Press the button 6 times (\*);
- The GREEN LED flashes ON-OFF at each press and release;
- After 10 seconds, the green LED flashes 6 times (0.5s ON; 0.5s OFF).

If a heat request occurs during the programming of the post-purging function, the controller exits the menu without saving the new setting.

If a heat request occurs while the LED is flashing, the controller exits the menu but the new setting is saved.

**CONTROLLED SHUTDOWN AND RESTART**Enabling/disabling sequence:

- programming permitted in NORMAL FUNCTIONING and STANDBY mode;
- Press and hold the burner reset button for between 20 and 25 seconds;
- The GREEN LED flashes 3 times;
- Release the button;
- The GREEN LED stays OFF;
- Press the burner reset button once to enable the function. (\*);
- Press the burner reset button twice to select one shutdown every hour. (\*);
- Press the burner reset button 3 times to select one shutdown every 24 hours. (\*);
- The GREEN LED flashes ON-OFF at each press and release;
- After 10 seconds, the GREEN LED flashes for the programmed number of times (0.5s ON; 0.5s OFF).

Changes to the setting of the controlled shutdown and restart function become active:

- after the next heat request from the thermostat (HT);
- after the next controlled shutdown and restart;
- after a flame failure during normal functioning;
- after power has been switched off and back on again.

**DISPLAYING THE LAST LOCKOUT**

The burner controller lets you display the last lockout stored in memory. To do so, access the "Programming menu". This page can be accessed during NORMAL FUNCTIONING or STANDBY mode.

Sequence for displaying the last lockout in memory:

- Press and hold the burner reset button for between 25 and 30 seconds;
- The GREEN LED flashes 4 times;
- Release the button;
- The type of lockout is displayed for 10 seconds.

Lockout type display time can be extended (for another 10 seconds) by pressing the reset button again while the lockout type is being displayed.

- (\*) Always wait 1 second between every press and release of the button to ensure correct interpretation of the command.

### 3.5 Two-stage burner

Used in models: **INSIEME EVO COND** 55 LN and 70 LN.

#### 3.5.1 Burner control and adjustment

##### ADJUSTING PUMP PRESSURE

To adjust the first stage: turn the adjusting screw (1) until the pressure value indicated in the table is obtained.  
 To adjust the second stage: turn the adjusting screw (2) until the pressure value indicated in the table is obtained.  
 Turn clockwise to increase and counter-clockwise to decrease the pressure.

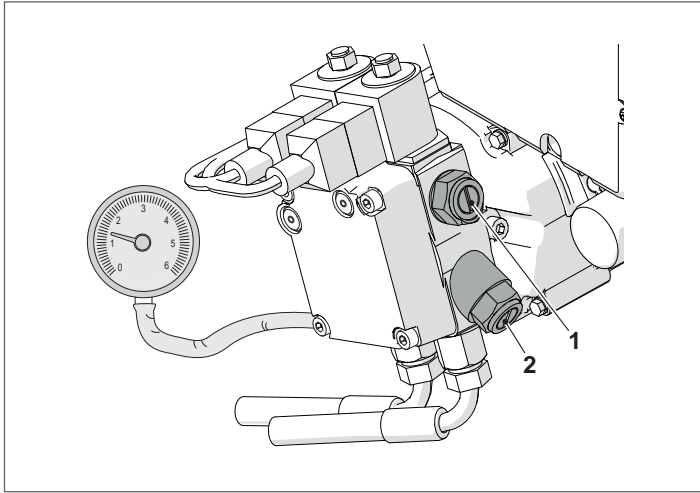

Adjusting pump pressure	INSIEME EVO COND	
	55 LN (*)	70 LN (*)
1st stage	13	14,5
2nd stage	23	23,7

(\*) Burner with oil heater

##### ADJUSTING THE AIR DAMPER

The air damper can be adjusted without removing the burner cover.

- To adjust the first stage: loosen the knob (1), move it to the desired position indicated by the index (2) on the scale (3) and tighten the knob (1) to lock the adjustment.
- To adjust the second stage: loosen the screw (4), turn the ring nut (5) until the required adjustment is made and tighten the screw (4) to a torque of 0.8 Nm.

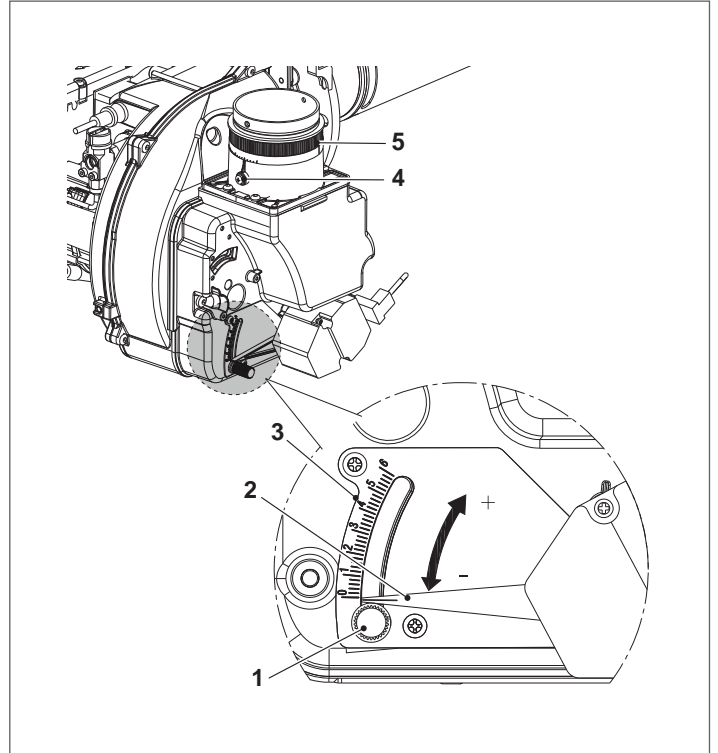

Adjusting the air damper	INSIEME EVO COND	
	55 LN (*)	70 LN (*)
1st stage	1,4	0
2nd stage	1,6	2,5

(\*) Burner with oil heater

### 3.5.2 Burner functioning and programming

#### Normal functioning

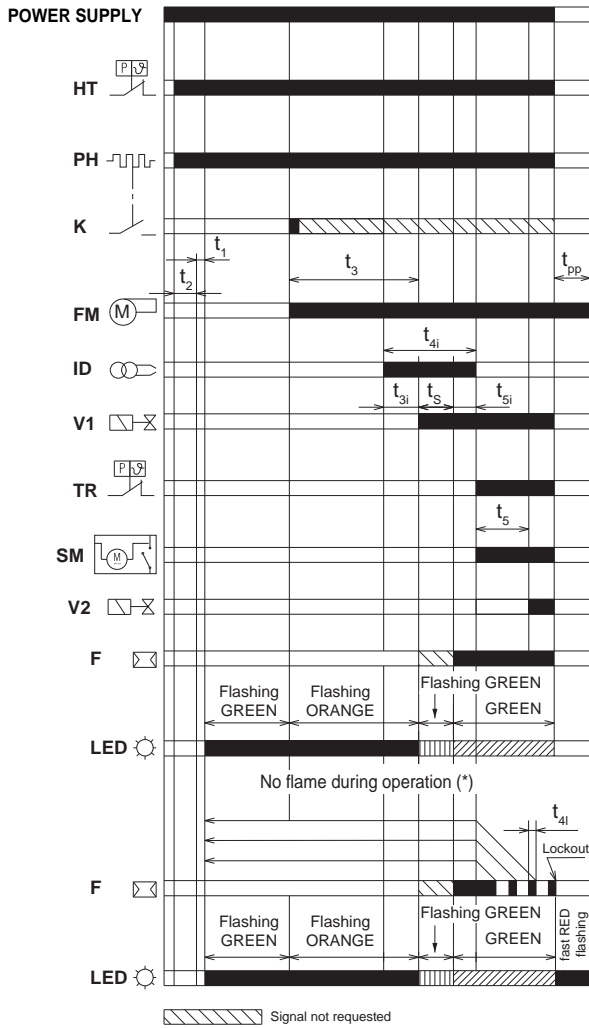

- HT** Heat request
- PH** Heating element
- K** Thermostat for enabling start-up after pre-heating
- FM** Fan motor
- ID** Ignition electrode
- F** Flame sensor
- LED** Colour of button LED
- SM** Air damper opener servomotor
- t<sub>1</sub>** Wait time
- t<sub>2</sub>** Initialisation time for checking
- t<sub>3</sub>** Pre-purging time
- t<sub>3i</sub>** Pre-ignition time
- t<sub>3l</sub>** Check for presence of extraneous light during pre-purging phase
- t<sub>4i</sub>** Reaction time to achieve safety condition due to flame loss
- t<sub>4l</sub>** Total ignition time
- t<sub>5</sub>** Delay time between the 1st and 2nd stage
- t<sub>5i</sub>** Post-ignition time
- t<sub>s</sub>** Safety time
- t<sub>pp</sub>** Post-purging time
- V1** 1st stage valve
- V2** 2nd stage valve

	DESCRIZIONE	VALUE
t0	Standby: the burner waits for a heat request	-
t1	Standby time for an input signal: reaction time, control box remains in waiting mode for t1	2 sec
t1l	Flame or flame simulation detected before demand for heat: the control box remains idle.	25
t2	Initialisation verification time: time following startup of main power supply	< 4,5 sec
t2l	Checks extraneous light or parasite flame during t2: waiting mode for t2l, then lockout: the motor does not start	25 sec
t2p	Max. light oil preheating time: waiting state for t2p, then the lockout takes place	max 600
t3	Pre-purging time: the fan motor is running, then the valve is activated	15 sec
t3l	Checks extraneous light or parasite flame during pre-purging: control box goes into lockout at the end of t3l	25 sec
t3i	Spark pre-ignition time	2 sec
ts	Safety time	5 sec
t4i	Total spark ignition time	10 sec
t4l	Reaction time to achieve safety condition due to flame loss	< 1 sec
t5	Delay time between the 1st and the 2nd stage: the 2nd stage valve opening time after the 1st stage valve opening depends on the air damper opener servomotor opening time	4 ÷ 8
t5i	Spark post-ignition time	3 sec
-	Minimum time to reset the control box using reset button	0,4 sec
tr	Cycle repetition: max. 3 repeats of the complete ignition sequence if flame fails during normal functioning; the controller enters lockout if no flame is detected after the last ignition attempt	3 repeats
tpp	Post-purging time: supplementary purge at the end of the heat request Post-purging can be interrupted by a new heat request	60 sec

Lockout caused by ignition failure

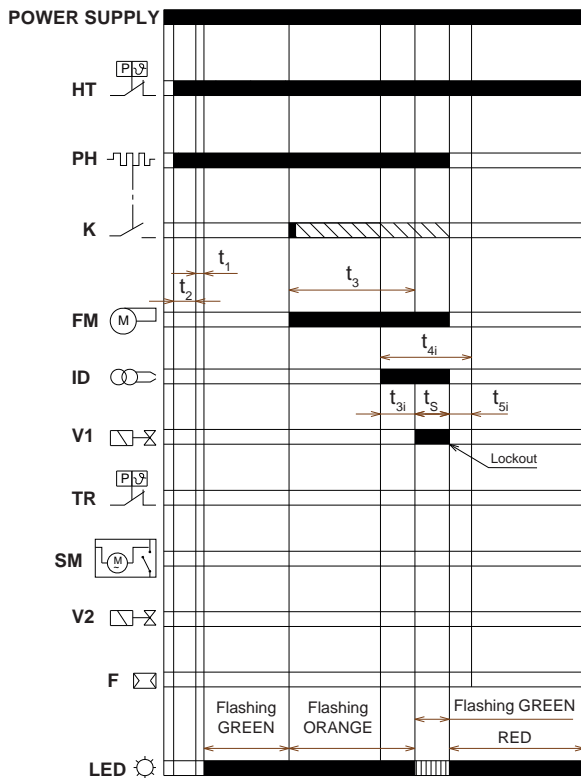

- HT Heat request
- PH Heating element
- K Thermostat for enabling start-up after pre-heating
- FM Fan motor
- ID Ignition electrode
- F Flame sensor
- LED Colour of button LED
- SM Air damper opener servomotor
- t1 Wait time
- t2 Initialisation time for checking
- t3 Pre-purging time
- t3i Pre-ignition time
- t3l Check for presence of extraneous light during pre-purging phase
- t4i Reaction time to achieve safety condition due to flame loss
- t4l Total ignition time
- t5 Delay time between the 1st and 2nd stage
- t5i Post-ignition time
- ts Safety time
- tpp Post-purging time
- V1 1st stage valve
- V2 2nd stage valve

Lockout caused by extraneous light during pre-purging

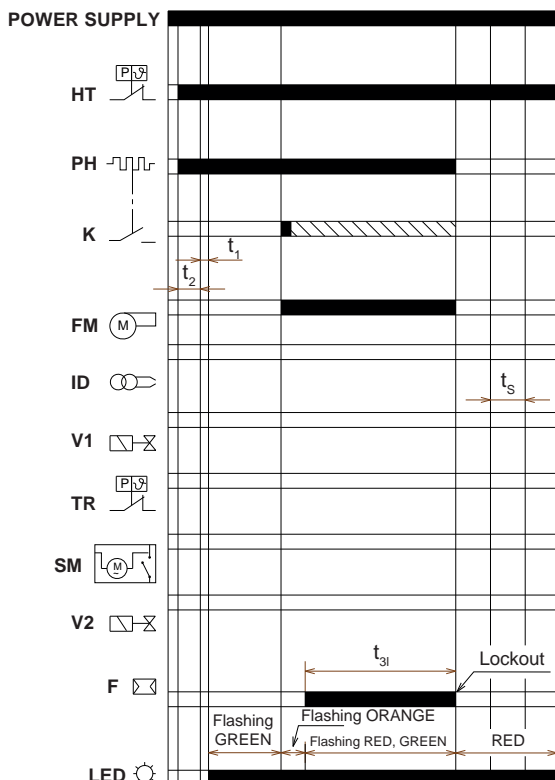

	DESCRIZIONE	VALUE
t0	Standby: the burner waits for a heat request	-
t1	Standby time for an input signal: reaction time, control box remains in waiting mode for t1	2 sec
t1l	Flame or flame simulation detected before demand for heat: the control box remains idle.	25
t2	Initialisation verification time: time following startup of main power supply	< 4,5 sec
t2l	Checks extraneous light or parasite flame during t2: waiting mode for t2l, then lockout: the motor does not start	25 sec
t2p	Max. light oil preheating time: waiting state for t2p, then the lockout takes place	max 600
t3	Pre-purging time: the fan motor is running, then the valve is activated	15 sec
t3l	Checks extraneous light or parasite flame during pre-purging: control box goes into lockout at the end of t3l	25 sec
t3i	Spark pre-ignition time	2 sec
ts	Safety time	5 sec
t4i	Total spark ignition time	10 sec
t4l	Reaction time to achieve safety condition due to flame loss	< 1 sec
t5	Delay time between the 1st and the 2nd stage: the 2nd stage valve opening time after the 1st stage valve opening depends on the air damper opener servomotor opening time	4 ÷ 8
t5i	Spark post-ignition time	3 sec
-	Minimum time to reset the control box using reset button	0,4 sec
tr	Cycle repetition: max. 3 repeats of the complete ignition sequence if flame fails during normal functioning; the controller enters lockout if no flame is detected after the last ignition attempt	3 repeats
tpp	Post-purging time: supplementary purge at the end of the heat request Post-purging can be interrupted by a new heat request	60 sec

Functioning status display

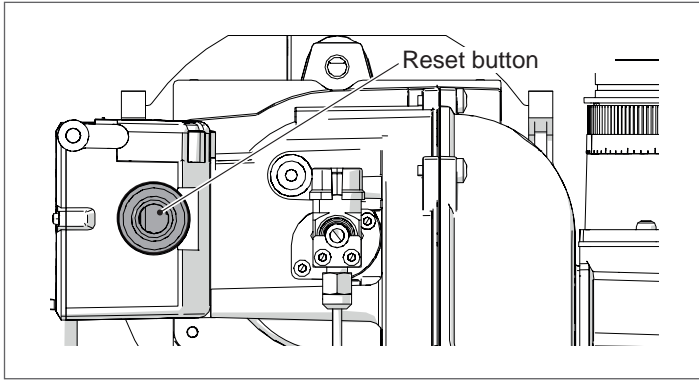

Functioning status	Reset button LED colour	Flash time	Seconds	
			ON	OFF
Heat request standby	-	-	-	-
Pre-heating time	● Flashing GREEN	-	0,5	2,5
Pre-ventilation	○ Flashing ORANGE	-	0,5	0,5
Safety time without flame	● Flashing GREEN	-	0,5	0,5
Safety time with flame	● GREEN	-	Steady ON	
Normal functioning position	● GREEN	-	Steady ON	



Fault diagnosis - lockouts

Fault description	Reset button LED colour	Flash time	Seconds	
			ON	OFF
Extraneous light or false flame signal	●● GREEN, RED alternate flashing	-	0,5	0,5
Electrical power voltage fault	○ Flashing ORANGE	Slow	2,5	2,5
Electrical power frequency fault	○ ORANGE	-	Steady ON	Steady ON
Flame control voltage fault	○● ORANGE, GREEN alternate flashing	Fast	0,2	0,2
Reset / remote reset button error	●● GREEN, RED alternate flashing	Fast	0,2	
Malfunction in communications between micro-processors	○● ORANGE, GREEN alternate flashing	Reversed	0,5	
Lockout for flame failure after Ts	● RED	-	Steady ON	Steady ON
Lockout for extraneous light or false flame signal	● RED flashing	-	0,5	0,5
Lockout for maximum number of cycle repetitions (flame losses during operation)	● RED flashing	Fast	0,2	0,2
Lockout for exceeding maximum pre-heating time	● RED flashing	-	0,5	2,5
Lockout for fan motor fault	●○ RED, ORANGE flashing	Reversed	2,5	0,5
Lockout due to fault inside the 1st stage valve circuit	●● RED, GREEN flashing	Reversed	2,5	0,5
Lockout due to fault inside the 2nd stage valve circuit	● RED flashing	Reversed	2,5	0,5
Lockout for EEPROM fault	○● ORANGE, GREEN alternate flashing	-	0,5	0,5

**Lockout types**

Whenever a lockout occurs, the control box shows the reasons for the fault (and the reasons can be identified by the reset button colour).

Description of lockout	Lockout time	Led colour	Probable cause
Presence of extraneous light at motor start	After 25 seconds	RED flashing	Presence of a false flame at a later stage
Pre-heating not finished	After 600 seconds	RED flashing	Light oil heater resistance fault Starter switch or thermostat fault
Detection of extraneous light during purging	After 25 seconds	RED flashing	Presence of false flame signal during pre-purging
Flame not detected by end of safety time	5 seconds after the activation of the fuel oil valve	RED always ON	Flame sensor faulty or dirty Light oil valve faulty or dirty Faulty ignition transformer Burner badly adjusted Fuel oil not present
Flame failure during functioning	After 3 ignition attempts	RED flashing	Burner not calibrated correctly Light oil valve faulty or dirty Flame sensor faulty or dirty
Fan motor fault	Immediate	RED, ORANGE flashing	Faulty fan motor Fan motor not connected
Fault with the light oil 1st stage valve control circuit	Immediate	RED, GREEN flashing	Light oil valve faulty Light oil valve control circuit faulty
Fault with the light oil 2nd stage valve control circuit	Immediate	RED flashing	Internal control circuit of the 2nd stage valve faulty
EEPROM fault	Immediate	ORANGE, GREEN flashing	Faulty internal memory

-  To reset the control box after visual diagnostics have been displayed, you must press the reset button.
-  In the event the burner stops, in order to prevent any damage to the installation, do not unblock the burner more than twice in a row. If the burner locks out for a third time, contact the Technical Assistance Service.
-  In the event there are further lockouts or faults with the burner, the maintenance interventions must only be carried out by qualified, authorised personnel, in accordance with the contents of this manual and in compliance with the standards and regulations of current laws.

## MAIN BURNER FUNCTIONS

### FUEL PRE-HEATING FUNCTION

If the burner features the fuel pre-heating function, in the presence of a start request from the boiler's heat request thermostat, it waits for the closing of the start-up thermostat (or pre-heating thermostat, K) positioned at the nozzle holder. If the start thermostat (or preheating thermostat, K) does not close within 600 seconds, the burner will reach the lockout condition. If the flame goes out during operation, the burner carries out the recycle if the contact of the start-up thermostat (or the pre-heating one, K) is closed.

If during operation the flame goes out and the start-up thermostat contact (or preheating thermostat, K) is open, the burner remains in ventilation for the duration of the post-purging time (if entered), then the ventilation stops and the burner waits for the closing of the start thermostat contact (or preheating thermostat, K) to restart with the pre-purging time.

### SHUTDOWN TEST

If the reset button is pressed during operations for more than 5 seconds and less than 10 seconds, the burner switches off, the light oil valve closes, the flame goes out and the start-up sequence restarts.

If the test is enabled, the number of repetitions of the start sequence (see "CYCLING AND THE SEQUENCE REPETITION LIMIT" on page 74) and the number of possible restarts (see "PROTECTION RESET" on page 74, are restored.

### CONTROLLED SHUTDOWN AND RESTART

After 24 hours of continuous operation, the control box starts the automatic sequence, followed by a restart, in order to check for a possible flame fault.

It is possible to set this automatic shut-down to 1 hour, (see paragraph "Menu access block diagram" on page 77). By default, this period is set to 24 hours.

The modification of the parameter setting for intermittent operation takes effect if:

- during the heat request, the switching off test function is enabled;
- there is a flame loss;
- the heat request switches off and then later restarts;
- the control box switches off and restarts;
- the automatic restart of the intermittent function (1 hour/24 hours) is started.

### CYCLING AND THE SEQUENCE REPETITION LIMIT

The burner controller has a cycling function. This means that the controller will repeat the complete startup sequence up to 3 times if the flame goes out during normal functioning.

If the flame fails 4 times during operations, this will cause the burner to lock out.

If there is a new heat request during the recycle, the 3 attempts are reset at the next heat request of the limit thermostat (TL).

#### NOTE:

After 510 seconds of continuous operation, a further attempt is made, if necessary.

When the power supply is disconnected, when there is a new heat request, all possible restart attempts are reset to 3 (maximum 3).

### EXTRANEIOUS LIGHT OR FALSE FLAME SIGNAL

The presence of a parasite flame or extraneous light can be detected in the stand-by state when the burner is stopped and waiting for a heat request or during preheating.

If the presence of a flame or extraneous light is detected also in the "t2" stage, the motor does not start until the flame signal has disappeared or until lockout has been reached.

If extraneous light or a false flame signal is detected when the fan motor is running during pre-purging, the burner stays in purge mode until the light or flame signal stops. If this does not occur within 25 seconds, the burner locks out.

If, during pre-purging, a parasite flame or extraneous light is detected, the pre-purging time of 15 seconds is reset to zero and the time for checking the presence of the parasite flame or extraneous light starts (the motor continues to ventilate).

The function is cumulative and can be performed up to 2 times. If the parasite flame or extraneous light disappears before 25 seconds, the pre-purging time starts; if the parasite flame or extraneous light occurs again, the pre-purging time is reset to zero and the 25-second count for checking the presence of the parasite flame or extraneous light restarts.

The burner also locks out if extraneous light or a false flame signal is detected three times.

If, during the recycle due to flame loss while operating and the consequent repetition of the start-up sequence, the parasite flame or the extraneous light is detected, the 25 seconds control countdown starts.

The fault is indicated by the flashing of the LED (see paragraph "Fault diagnosis - lockouts" on page 72).

### PRE- AND POST-IGNITION PHASE

During pre-ignition, the ignition electrode switches on 2 seconds before the fuel oil valve opens.

During post-ignition, the ignition electrode switches off 3 seconds after the end of safety time.

Ignition remains active throughout safety time.



In the event of continuous recycling or heat requests that are close together, the maximum allowed number of cycle repetitions for the ignition transformer is one every minute.

### PROTECTION RESET

The burner can be reset only 5 times consecutively, then power supply has to be disconnected for a new 5 reset possibilities.

The burner can only be reset if power supply is applied to the control box.

### RESET / REMOTE RESET BUTTON ERROR

In any state (ON/OFF thermostat), if the release button or the remote release button fails or remains pressed for more than 60 seconds, the fault is indicated by the flashing LED (see paragraph "Fault diagnosis - lockouts" on page 72) as long as it is present.

- This fault is only displayed and the led stops blinking when the fault disappears.
- If the fault is detected during pre-purging, preheating or safety time, the burner does not stop and the start-up sequence continues.
- If the fault is detected during a lockout, the fault is not signalled and the burner cannot be reset.
- If the fault is detected during operation, the burner does not stop.

### MONITORING THE POWER SUPPLY VOLTAGE

The control box automatically measures the mains voltage. If the voltage is less than 160V or more than 280V, the burner stops, interrupts the operating cycle and remains in stand-by, signalling a fault. It is not possible to unlock the burner.

The fault is indicated by the flashing of the LED (see paragraph "Fault diagnosis - lockouts" on page 72).

The burner restarts when the voltage exceeds approx. 170V or if it returns below 270V.

- If the fault is detected with flame operation, the valve is immediately closed and the motor stops.
- If the anomaly is detected during pre-purging, the motor stops.
- If when the main power supply switch is closed or after there has been no power, the mains voltage stays within the intermediate values (160-170V or 270-280V) the burner does not start.
- If the burner is in lockout, the mains voltage is monitored but the fault is not signalled since the lockout signal is already present.

During the ignition time the mains voltage monitoring is deactivated.

### POWER SUPPLY FREQUENCY ERROR

The control equipment automatically detects the frequency of the main power supply in the range between 50 and 60 Hz; in both cases the operating times are checked. The LED flashes to indicate that there is a fault (see paragraph "Functioning status display" on page 72).

- If an error is detected before a heat request is made, the burner does not start up and the error is signalled.
- If an error is detected during pre-purging, the burner remains in purge mode and the error is signalled.
- If no error is detected during normal functioning, the burner continues to function normally.
- The burner starts up as soon as the error disappears.

### INTERNAL VOLTAGE ERROR

The control box automatically detects if the internal voltage works correctly. The fault is indicated by the flashing of the LED (see paragraph "Fault diagnosis - lockouts" on page 72).

- If an error is detected during initialisation, the burner does not start up.
- If an error is detected after a lockout, the burner will not start up.
- If an error is detected after a shutdown test, the burner will not start up.
- If no error is detected during normal functioning, the burner continues to function normally.
- The burner starts up as soon as the error disappears.

### FAN MOTOR CONTROL

The control box automatically detects the presence of the fan motor and, if it is disconnected, it performs a lockout.

The lockout is indicated by the flashing of the LED (see paragraph "Fault diagnosis - lockouts" on page 72).

### CHECKING THE 1ST STAGE VALVE CONTROL ELECTRONIC CIRCUIT

The control box detects the presence of an internal fault in the electronic control circuit of the 1st stage valve, the fault is indicated by the flashing led (see paragraph "Fault diagnosis - lockouts" on page 72):

- if the anomaly is detected during the initialisation, the burner goes into lockout.
- If the anomaly is detected during the pre-purging, the burner goes into lockout.
- During a recycling, if the fault is detected, the burner does not start and goes into lockout.
- The fault is not detected during normal flame operation, the burner remains in this state.
- The fault is not detected if the burner is in lockout.

### CHECKING THE 2ND STAGE VALVE CONTROL ELECTRONIC CIRCUIT

The control box detects the presence of an internal fault in the electronic control circuit of the 2nd stage valve, the fault is indicated by the flashing led (see paragraph "Fault diagnosis - lockouts" on page 72):

- if the anomaly is detected during the initialisation, the burner goes into lockout.
- If the anomaly is detected during the pre-purging, the burner goes into lockout.
- During a recycling, if the fault is detected, the burner does not start and goes into lockout.
- If the fault is detected when the motor activation command and valve 1 command are present, the burner locks out.
- The fault is not detected if the burner is in lockout.

### POST-PURGING

The post-purging function keeps the fan running for a set time after the burner shuts down provided there is no new heat request.

When the contacts of the heat request thermostat open, the burner controller shuts down the flame and shuts off the oil supply.

Post-purging does not occur:

- after a lockout;
- if the heat request is interrupted during pre-purging.

Post-purging occurs:

- if the heat request is interrupted during the safety time;
- if the heat request is interrupted during normal operation.

### NOTE:

If extraneous light or a false flame signal is detected during post-purging, the burner locks out after 25 seconds.

If a new heat request is detected during post-purging, post-purging time is reset, the fan motor stops and a new burner ignition cycle is initiated.

**EEPROM CHECK**

The burner controller automatically checks for errors in the microcontroller EEPROM and enters lockout if an error is detected. The lockout is indicated by the flashing of the LED (see paragraph "Fault diagnosis - lockouts" on page 72).

**CHECKING THE INTERNAL COMMUNICATIONS BETWEEN THE MICRO-CONTROLLERS**

The control box automatically detects the communication failure between micro-controllers and displays a fault. The fault is indicated by the flashing led (see paragraph "Fault diagnosis - lockouts" on page 72).

**LOCKOUT LOG**

The control box allows the logging of the type and number of lockouts that have occurred and keeps them even without the electrical power supply. The lockout log allows the displaying of the last 10 lockouts (see paragraph "Menu access block diagram" on page 77). Once the programming menu page has been reached by pressing the reset button the last lockout is displayed, pressing 10 times displays the least recent lockout (each time the burner reaches the lockout condition the oldest one is removed). Five seconds after the last button pressing, the lockout type is displayed (see paragraph "Fault diagnosis - lockouts" on page 72).

**LOGGING OF BURNER OPERATING PARAMETERS**

The control box allows you to log the operating time of the opening of the 1st stage valve. That way, you can determine how much fuel has been consumed during operation. The frequency of the count is 1 second. Saving to memory (EEPROM) of the data occurs every 30 minutes if the burner is on. Saving to memory is carried out even if in the previous 30 minutes the control box was operating only for a short period of time. If the control box is cut off from the mains power supply between one saving and the next (after 30 minutes) the information about this interval is lost. If in the interval between one saving and the next a lockout is set, there is writing to memory that involves also the logging of the operating hours. Together with the operating hours also the number of the burner's 1st stage valve openings is saved. In the menu (see section "Menu access block diagram" on page 77) it is possible to reset both the operating days and the number of valve openings of the 1st stage independently.

- The display of the number of openings of the 1st stage valve is a maximum of: 16.777.215 (after which it is reset).
- The displaying of the number of days of the 1st stage valve is a maximum of: 65.535 (after which it is reset).

**DEACTIVATION OF AUTOMATIC PRE-HEATING**

The automatic pre-heating functioning can be deactivated by pressing the reset or remote reset button. Pre-heating remains de-activated until:

- a lockout occurs;
- mains power fails or is switched off;
- the boiler shuts down for a controlled shutdown and restart.

Pre-heating de-activation sequence	Colour of button LED
Only de-activate the pre-heating if no lockout or errors are present	-
Deactivate the pre-heating by means of the reset or remote reset button.	-
Switch on the burner and simultaneously hold down the reset or remote reset button for 3 seconds.	RED
Release the reset or remote reset button within 3 seconds.	OFF
The burner will de-activate pre-heating only if the reset or remote reset button is released within 3 seconds.	-

The deactivation of the automatic pre-heating function is not lost if the switching off test function is active or if the heat request thermostat opens.

**PROGRAMMING MENU**

**General**

The programming menu can be accessed via the integrated reset button during OPERATION and in STAND-BY. If in the menu page the reset button is not pressed within 10 seconds, the page will be automatically quitted and a green led will start flashing for the time set. If the number of presses on the reset button exceeds the maximum allowable, the value that stays in memory will be the maximum one. If the reset button is pressed for more than 60 seconds, a button error will be displayed and the control box will restart.

Menu access block diagram

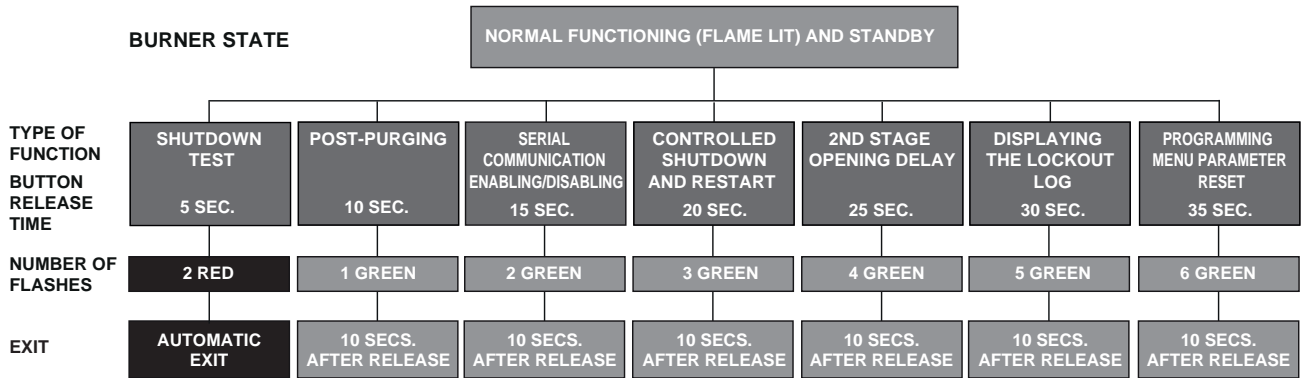

Function	Button release time	No. of LED flashes for menu page	No. of times reset button is pressed	No. of blinks of the LED (green)	Exit menu
Shutdown test	$5s \leq t < 10s$	2 blinks RED	/none	/none	Automatic when flashing finishes
Post-purging	$10s \leq t < 15s$	1 flash GREEN	1 = 10 secs. 2 = 20 secs. 3 = 30 secs. 4 = 60 secs. (default) 5 = 120 secs. 6 = 0 secs. (disabled)	1 flash 2 flashes 3 flashes 4 flashes 5 flashes 6 flashes	10 seconds after button is released
Serial communication enabling/disabling	$15s \leq t < 20s$	2 blinks GREEN	1 = activated 2 = deactivated (default)	1 flash 2 flashes	10 seconds after button is released
Controlled shutdown and restart	$20s \leq t < 25s$	3 blinks GREEN	1 = 1 hour 2 = 24 hours (default)	1 flash 2 flashes	10 seconds after button is released
2nd stage opening delay	$25s \leq t < 30s$	4 blinks GREEN	1 = 10 sec. 2 = 20 sec. 3 = 30 sec. 4 = 0 sec. (disabled)(default)	1 flashing 2 flashings 3 flashings 4 flashings	10 seconds after button is released
Displaying the lockout log	$30s \leq t < 35s$	5 blinks GREEN	1 = last lockout 2 = 9th lockout 3 = 8th lockout 4 = 7th lockout 5 = 6th lockout 6 = 5th lockout 7 = 4th lockout 8 = 3rd lockout 9 = 2nd lockout 10 = less recent lockout	Display of the type of lockout, (see paragraph "Fault diagnosis - lockouts" on page 72)	10 sec after the release of the button (if at level 1). When at level 2, 10 sec after the display of the type of lockout or else by pressing the button again before 10 sec, you return to level 1, from which, 10 seconds after no button has been used, you exit the menu
Programming menu parameter reset	$35s \leq t < 40s$	6 blinks GREEN	1 = reset of the lockout log 2 = reset of the no. of lockouts 3 = reset of operating hours 4 = reset of the no. of heat requests 5 = reset of the default values of the menu parameters	/none	10 seconds after button is released

## SHUTDOWN TEST

### Shutdown test sequence:

- Programming allowed in OPERATING mode and in STANDBY.
- Press button for 5 sec.  $\leq t < 10$  sec.
- RED led Blinking 2 times (0.2s. ON; 0.2s. OFF).
- Release the button.
- The burner shuts down and restarts.

The burner shuts down then restarts automatically. Each shutdown test resets (zeroes) the ignition cycle count. No LEDs flash when you exit the shutdown test menu.

## POST-PURGING

Post-purging time can be set to a maximum of **120 seconds**. To set post-purging time, proceed as follows.

### Post-purging programming sequence:

- programming permitted in NORMAL FUNCTIONING and STANDBY mode;
- Press and hold the burner reset button for between 10 and 15 seconds;
- The GREEN LED flashes 1 once;
- Release the button;
- The GREEN LED stays OFF;
- Press the button from 1 to 5 times (\*);
- The GREEN LED flashes ON-OFF at each press and release;
- After 10 seconds, the GREEN LED flashes for the programmed number of times (0.5s ON; 0.5s OFF).

### Post-purging de-activation sequence:

- resetting permitted in NORMAL FUNCTIONING and STANDBY mode;
- Press and hold the burner reset button for between 10 and 15 seconds;
- The GREEN LED flashes 1 once;
- Release the button;
- The GREEN LED stays OFF;
- Press the button 6 times (\*);
- The GREEN LED flashes ON-OFF at each press and release;
- After 10 seconds, the green LED flashes 6 times (0.5s ON; 0.5s OFF).

If a heat request occurs during the programming of the post-purging function, the controller exits the menu without saving the new setting.

If a heat request occurs while the LED is flashing, the controller exits the menu but the new setting is saved.

## CONTROLLED SHUTDOWN AND RESTART

### Enabling/disabling sequence:

- programming permitted in NORMAL FUNCTIONING and STANDBY mode;
- Press and hold the burner reset button for between 20 and 25 seconds;
- The GREEN LED flashes 3 times;
- Release the button;
- The GREEN LED stays OFF;
- press the button once to enable a shut-down every hour (\*);
- press the button 2 times to enable a shut-down every 24 hours (\*);
- The GREEN LED flashes ON-OFF at each press and release;
- After 10 seconds, the GREEN LED flashes for the programmed number of times (0.5s ON; 0.5s OFF).

Changes to the setting of the controlled shutdown and restart function become active:

- after the next heat request from the thermostat (HT);
- after the next controlled shutdown and restart;
- after a flame failure during normal functioning;
- after power has been switched off and back on again.

## SETTING THE 2ND STAGE OPENING DELAY

The control box allows the setting of the opening delay of the 2nd stage from the 1st stage, see paragraph "Menu access block diagram" on page 77.

### Setting sequence of the 2nd stage opening delay :

- Programming allowed in OPERATING mode and in STANDBY;
- Press the button for 25 sec.  $\leq t < 30$  sec.;
- GREEN led blinking 4 times;
- Release the button;
- GREEN led OFF;
- Press the button once to enable a delay of 10 seconds (\*);
- Press the button 2 times to enable a delay of 20 seconds (\*);
- Press the button 3 times to enable a delay of 30 seconds (\*);
- GREEN led ON and OFF at each pressure and release;
- After 10 seconds, the GREEN LED flashes for the programmed number of times (0.5s ON; 0.5s OFF).

## SERIAL COMMUNICATION SETTING

The control box allows the setting of the serial communication, see paragraph "Menu access block diagram" on page 77.

### Serial communication setting sequence:

- Programming allowed in OPERATING mode and in STANDBY;
- Press the button for 15 sec.  $\leq t < 20$  sec.;
- GREEN led blinking 2 times;
- Release the button;
- GREEN led OFF;
- Press the button once to activate the serial communication (\*);
- Press the button twice to disable the serial communication (\*);
- GREEN led ON and OFF at each pressure and release;
- After 10 seconds, the GREEN LED flashes for the programmed number of times (0.5s ON; 0.5s OFF).

- (\*) Always wait 1 second between every press and release of the button to ensure correct interpretation of the command.

## DISPLAYING THE LOCKOUT LOG

The control box allows you to display the last 10 lockouts that occurred and were logged, accessing the "Programming menu". Access to this page is possible both in STANDBY and in the OPERATING status.

### Display sequence of the last lockout that occurred:

- Keep the button pressed for at least 30 sec. and not more than 35 sec.;
- GREEN led blinking 5 times.;
- Release the button;
- Display of the type of lockout stored for 10 sec.;
- Press the button again to allow the display in the following and oldest lockout.;
- After 10 times, the least recent lockout is displayed. Press the button one more time to display again the most recent lockout.;
- The lockout display continues for another 10 sec..

## RESETTING THE PROGRAMMING MENU PARAMETERS AND THE LOCK-OUT LOG

The control box allows you to reset the log and the number of lockouts, the operating hours, the number of ignitions and to recover the menu default parameter values, see paragraph "Menu access block diagram" on page 77.

Reset sequence of the programming menu parameters and the lockout log:

- Programming allowed in OPERATING mode and in STAND-BY;
- Press the button for 35 sec.  $\leq t < 40$  sec.;
- GREEN led blinking 6 times;
- Release the button;
- GREEN led OFF;
- Press the button 1 time to reset the lockout log (\*);
- Press the button 2 times to reset the number of lockouts (\*);
- Press the button 3 times to reset the number of operating hours with flame (\*);
- Press the button 4 times to reset the number of heat requests (\*);
- Press the button 5 times to reset all the default values of the parameters of the PROGRAMMING MENU (\*);
- GREEN led ON and OFF at each pressure and release;
- After 10 seconds, the GREEN LED flashes for the programmed number of times (0.5s ON; 0.5s OFF).

(\*) Always wait 1 second between every press and release of the button to ensure correct interpretation of the command.

### 3.6 Error List

When a technical anomaly occurs, the control interface display shows a text message (small digit) and a number (large digit), which indicate the type and level of the detected error.

There are 3 error levels:

- 1 **Permanent:** heating and/or DHW requests are suspended and burner and circulator are switched off. For the error to disappear, keep the key ENTER/RESET on the control interface pressed for 3 seconds or reset the power supply by using the main switch.
- 2 **Temporary:** heating and/or DHW requests are suspended and burner and circulator are switched off. The error disappears automatically when the cause which generated it is solved.
- 3 **Alert:** the thermal unit is not locked out, but its functions may be limited according to the signalled alert code.

The log of the last ten errors occurred can be viewed through the error log (menu 9000 – installer level) (from Par. 9001 to Par. 9010).

#### 3.6.1 Permanent Errors

Message	Error No.	Description
Loc	01	Electronic board hardware fault. Relay deterioration.
Loc	10	Failed ignition/Burner error (see page 89 code of colours to identify the error).
Loc	20	Intervention of safety thermostat or flue limit thermostat
Loc	40	Insufficient pressure in primary circuit. Pressure < 0.5 bar for more than 10 minutes
Loc	42	Pressure transducer not connected or primary circuit pressure too high. Pressure > 2.5 bar for more than 10 minutes

If you see the "Loc 01" error, proceed as follows:

- Check that the phase and neutral power supply are connected correctly
- Replace the electronic board

### 3.6.2 Temporary Errors

Message	Error No.	Description
Err	29	Flue temperature too high
Err	36	Triggering (open circuit) of one or both pressure switches connected to the INAIL input. Only for 45 kW / 55 kW / 70 kW models based on what is required by current legislation.
Err	38	Flow meter disconnected or flow rate lower than minimum flow rate
Err	41	Primary circuit pressure insufficient (temporary)
Err	60	Domestic hot water probe in short circuit or disconnected.
Err	70	Delivery sensor short circuit or disconnection. Delivery sensor fault/delivery sensor temperature overload
Err	80	Return sensor fault/return sensor temperature overload
Err	90	Flue sensor faulty
Err	99	Too many resets from remote control. NO MORE RESETS
Err	100	Communication lost in zone 1 (temporary)
Err	101	Zone 1 limit thermostat triggering (temporary)
Err	102	Zone 1 delivery probe (temporary)
Err	104	Communication lost in zone 2 (temporary)
Err	105	Zone 2 limit thermostat triggering (temporary)
Err	106	Zone 2 delivery probe (temporary)
Err	108	Communication lost in zone 3 (temporary)
Err	109	Zone 3 limit thermostat triggering (temporary)
Err	110	Zone 3 delivery probe (temporary)

#### 3.6.3 Warnings

Message	Error No.	Description
Atte	44	Primary circuit pressure too high (P>2.5 bar) [TEMPORARY]
Atte	46	Pressure decreasing. Range not critical (0.5 bar < P < 0.8 bar) [TEMPORARY]
Air	--	Deaeration cycle in progress
Aleg	--	Anti-legionella cycle in progress
AFro	--	Anti-freeze cycle in progress

### 3.7 Temporary or short-term shut-down

In the event of temporary or short-term shut-down (e.g. due to holidays), proceed as follows:

- Remove the power supply by setting the main switch of the equipment and the main switch of the system to "OFF".
- If there is a danger of frost, keep the system on. To reduce fuel consumption, set the heating set point to the minimum allowed value.

### 3.8 Preparing for extended periods of disuse

If the appliance is not going to be used for a long period of time, the following operations should be carried out: set the main switch of the system to OFF and the main switch of the equipment to (0);

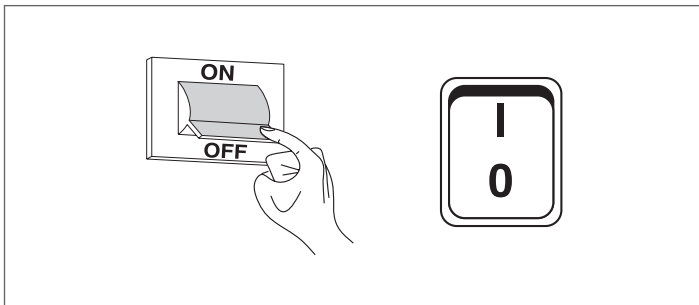

- close the fuel cock and heating circuit water cock.

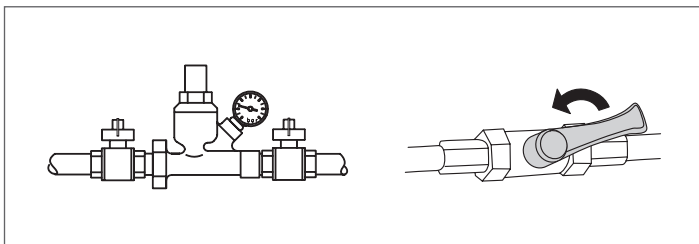

**⚠** Drain the central heating circuit if there is any risk of freezing.

### 3.9 Device cleaning and maintenance

It is essential to clean the boiler and remove carbon deposits from the surfaces of the heat exchanger in order to keep the boiler efficient and economical.

- ⚠** All cleaning operations MUST be performed under the following conditions:
- boiler cold
  - boiler switched OFF
  - Suitable personal protection equipment

Perform the following operations before beginning any maintenance or cleaning:

- set the main switch of the system to OFF and the main switch of the equipment to (0);

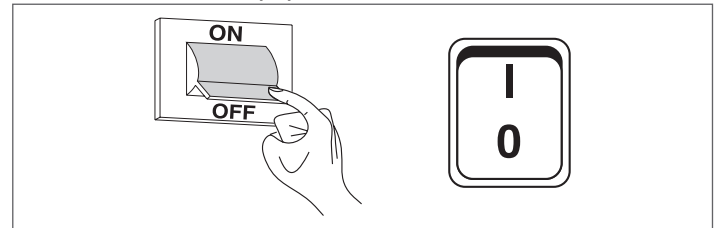

- close all external fuel shut-off cocks.

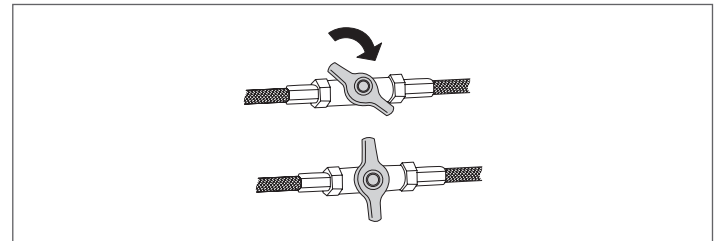

### 3.10 Annual cleaning

It is mandatory to perform maintenance and cleaning of the device at least once a year.

This operation, carried out by Technical Assistance Service or by professionally qualified personnel, is necessary to monitor and ensure that the flue pipes inside and outside of the device, the fan, the safety valves, the condensate removal devices, the water drainage tubes and all the measurement and control devices are in perfect working order.

#### 3.10.1 Cleaning and maintaining the burner

Proceed as follows to access the internal parts of the boiler:

- remove the fixing screw (2) and extract the front panel (1);

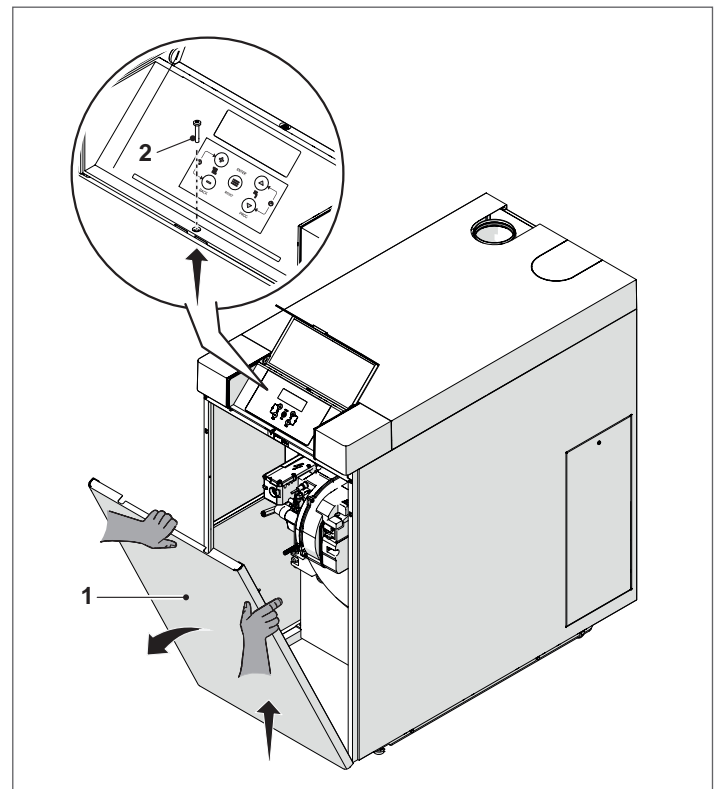

**REMOVING THE BURNER**

Proceed as follows to remove the burner:

- Close the fuel shut-off cocks;
- disconnect the connector (1);

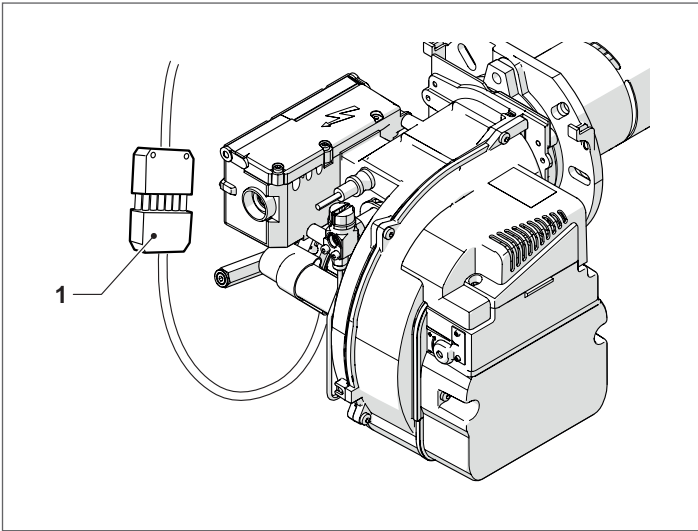

- Unscrew the fixing nut (2) and remove the burner;
- Pull the burner (3) out, taking care not to damage it;

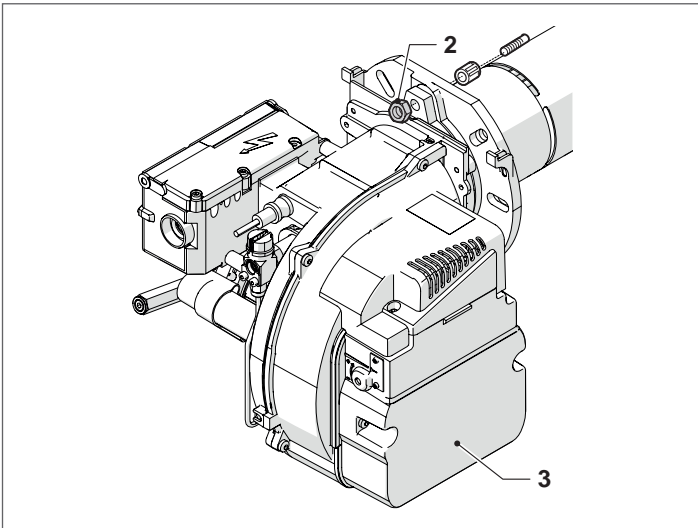

- Place the burner in an upright position.

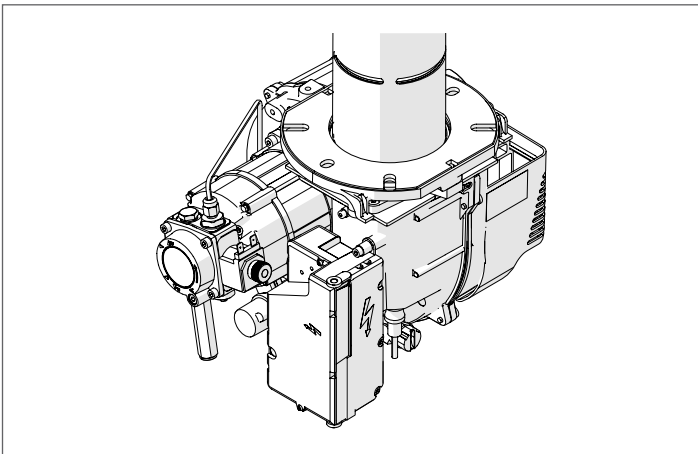

Reverse the above steps to reassemble.

**REMOVING THE BLAST TUBE**

Proceed as follows to remove the blast tube:

- Remove the screws (1) and remove the blast tube.
- disconnect the high voltage cable (2).

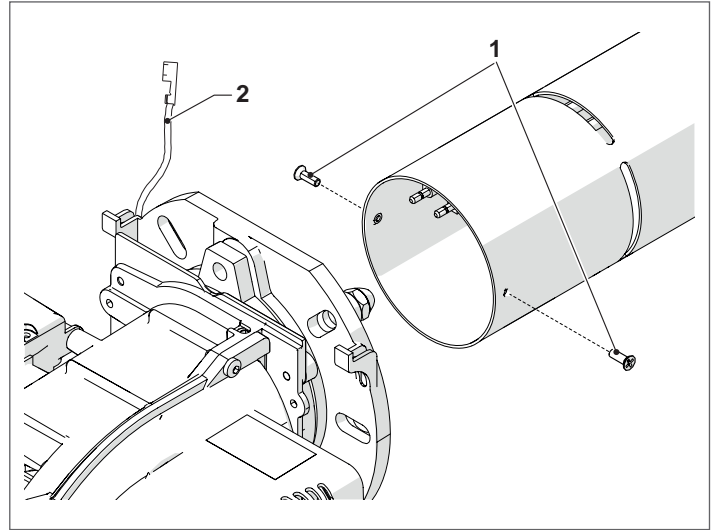

**⚠** With the blast tube removed, check its front edge to make sure that it is smooth, free from deposits, burns and dents. Reverse the above steps to reassemble.

**REPLACING THE NOZZLE**

	INSIEME EVO COND		
	45 LN	55 LN	70 LN
Nozzle type	1.0 80°HF Fluidics	0.85 80°HF Fluidics	1.1 80°HF Fluidics

Remove the blast tube then proceed as follows:

- Clean the electrodes without removing the clamp;
- Hold the nozzle holder (3) steady with one wrench while using a second wrench to remove the nozzle (4)

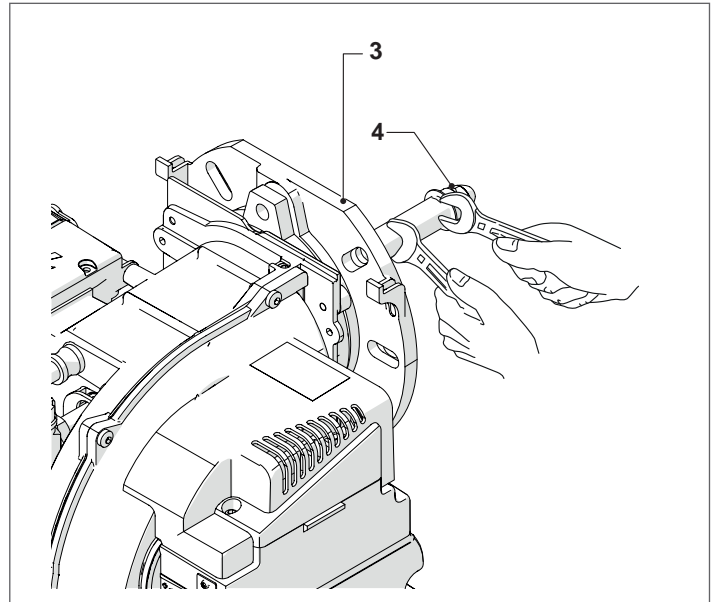

- Make sure that the new nozzle is exactly the same type and size as the old one
- Clean the contact and sealing surfaces
- manually drive and screw the new nozzle fully home, then tighten it properly.

**⚠** Do not use nozzles of different make, type and specifications to the original.

**ELECTRODE POSITIONING**

The positioning of the ignition electrodes (A) is fundamental to obtain reliable flame ignitions. Check their state of wear and correct positioning, as shown in the figure, and replace them if necessary.

**Mod. INSIEME EVO COND 45 LN**

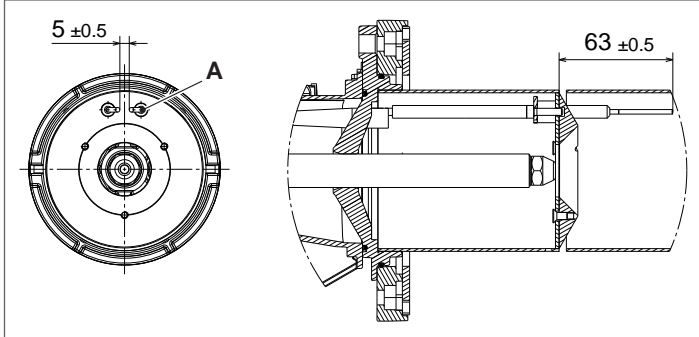

**Mod. INSIEME EVO COND 55 LN and 70 LN**

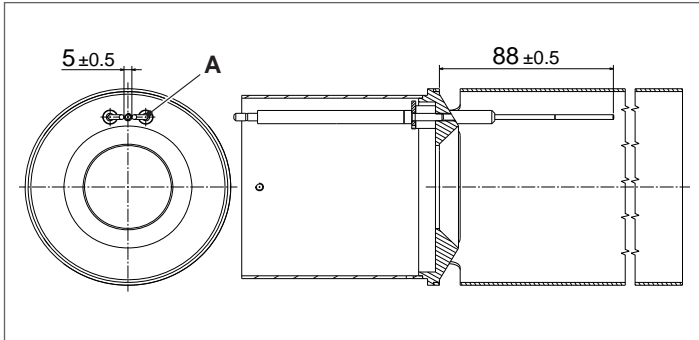

**⚠** It is essential to respect the dimensions in the figure.  
**REMOVING THE ELECTRODES**

Proceed as follows to remove the electrodes:

- Loosen the screw (1)
- Extract the electrodes and check them for wear

Reverse the above steps to reassemble.

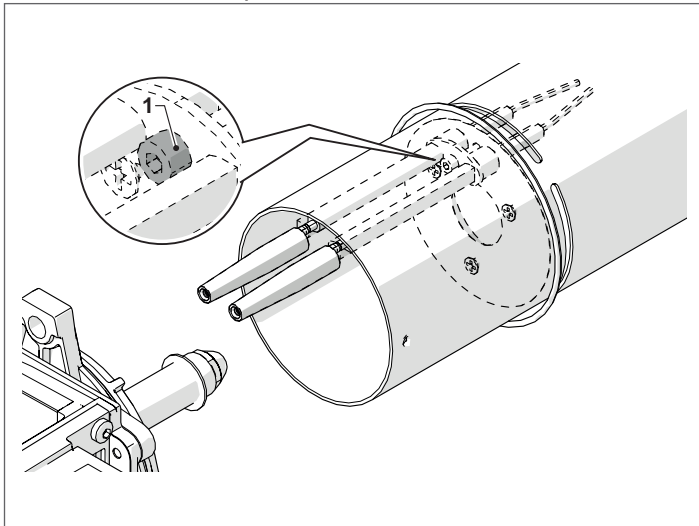

**REMOVING THE BURNER CONTROLLER**

The burner cover has to be removed first in order to remove the controller.

Proceed as follows:

- Loosen the screw (1), open the cover (2) and remove all the components inside
- Remove the coil (3)
- Unscrew and remove the two screws (4).

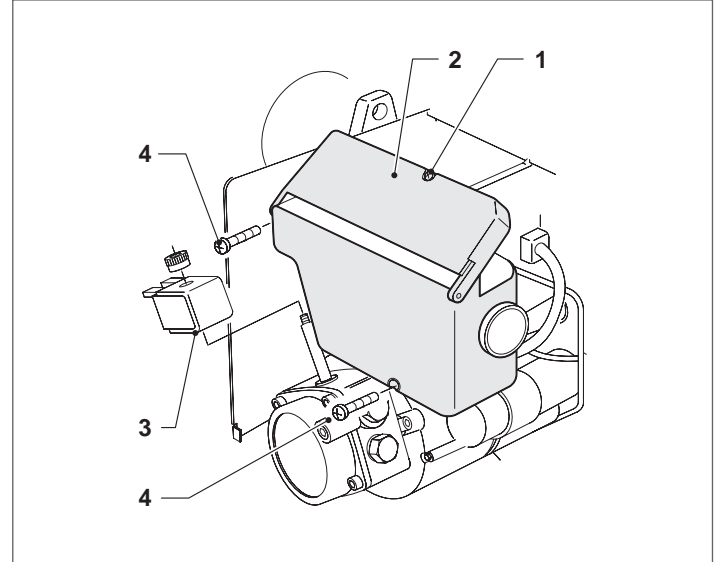

**⚠** This operation must be performed with the burner turned off and mains power disconnected.

**CLEANING THE FAN**

**⚠** Clean the inside and the rotor blades of the fan unit to remove any build-up of dust. Accumulated dust reduces the air flow and therefore reduces combustion efficiency, leading to increased emissions.

**⚠** Perform maintenance operations paying attention not to damage or unbalance the fan during cleaning operations.

Proceed as follows

- remove the socket (1), the cable from the cable clamp (2), undo the screws (3) and take out the air damper unit (4);
- clean the fan and the inside of the suction inlet, using a suitable brush and compressed air;
- if necessary, gently remove the fan by undoing the screw (5).

**Mod. INSIEME EVO COND 45 LN**

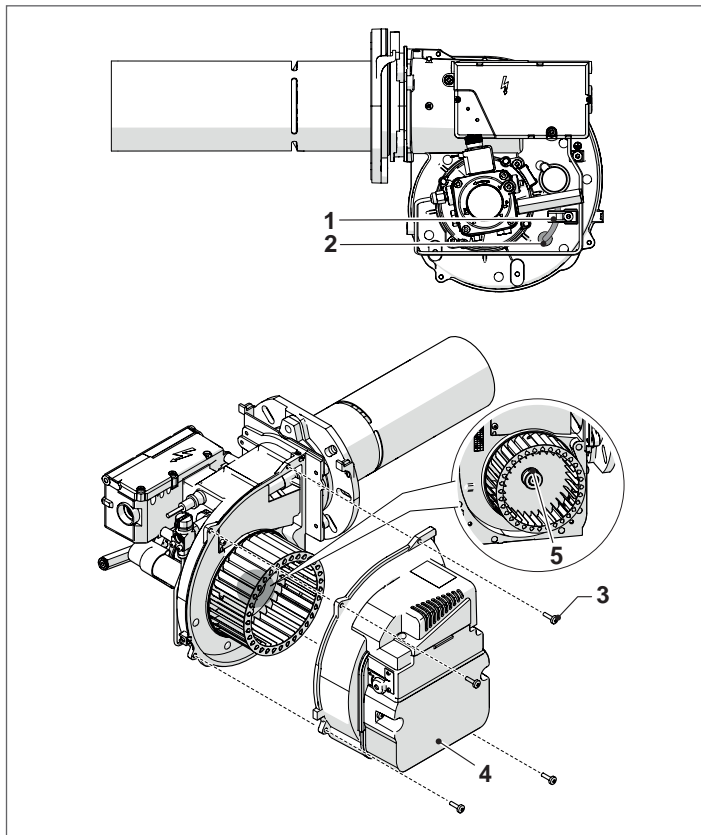

**Mod. INSIEME EVO COND 55 LN and 70 LN**

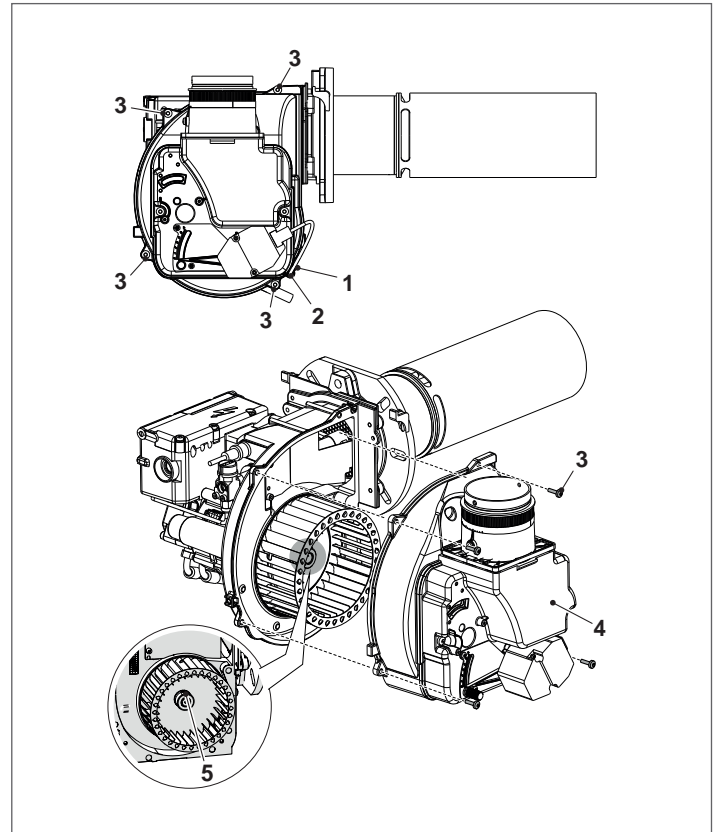

**⚠** When reassembling the fan, it is important to put it back in the correct position (B) and tighten the screw (5).

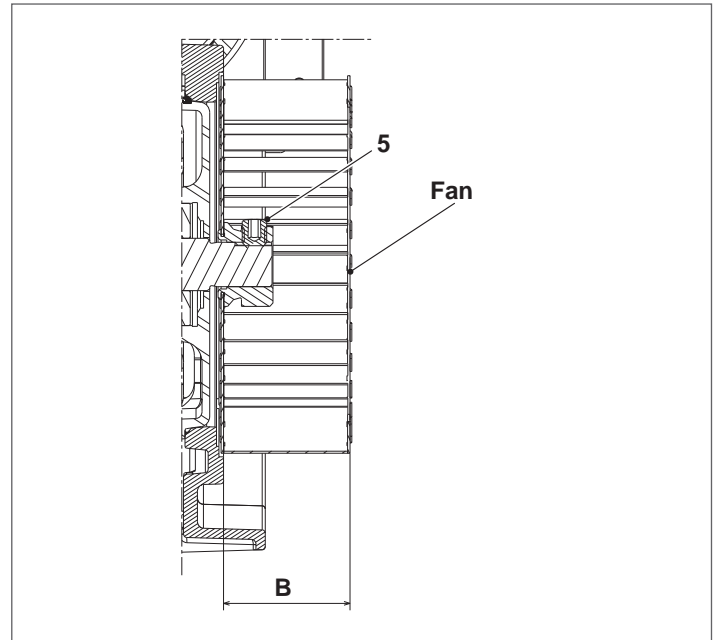

	INSIEME EVO COND	
	45 LN	55 LN/70 LN
B [mm]	61 ± 0,2	51 ± 0,2

- Reverse the above steps to reassemble. Take care to replace all burner parts in their original positions.

### 3.10.2 Boiler exchanger cleaning

Proceed as follows to access the internal parts of the boiler:

- remove the fixing screw (2) and extract the front panel (1);

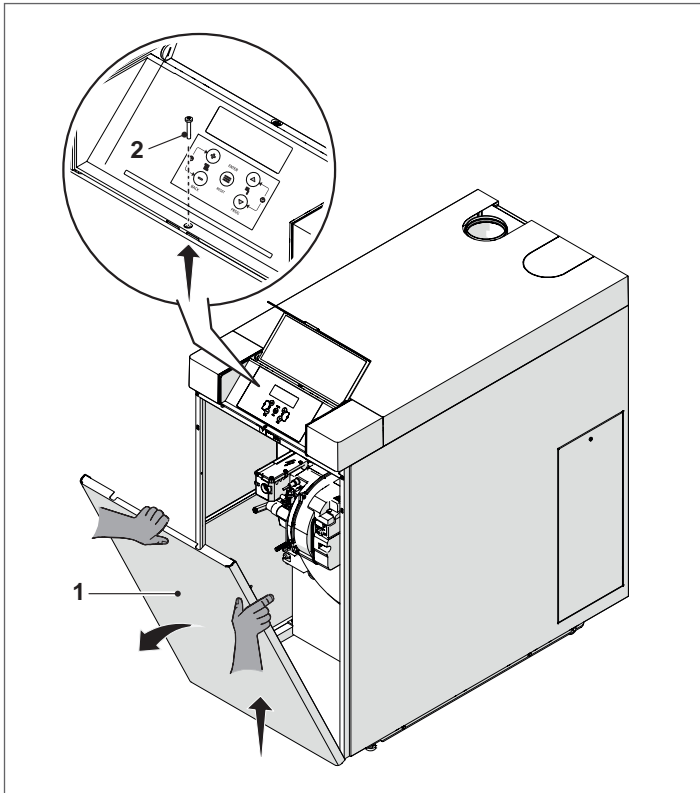

- Close the fuel shut-off cocks;
- disconnect the connector (3);

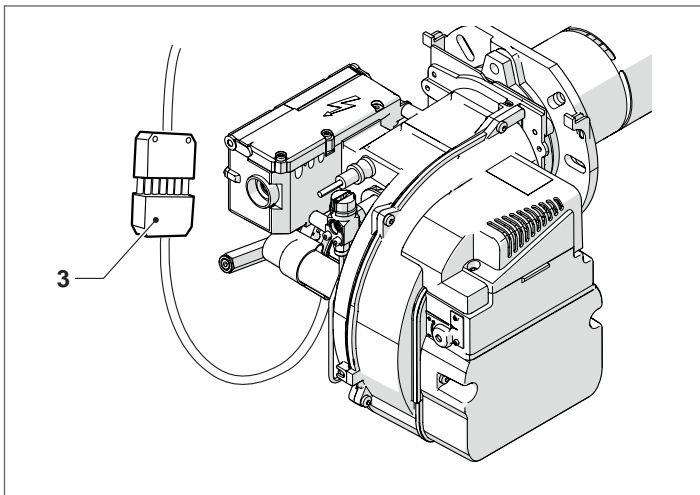

- Remove the four fastening nuts (4).

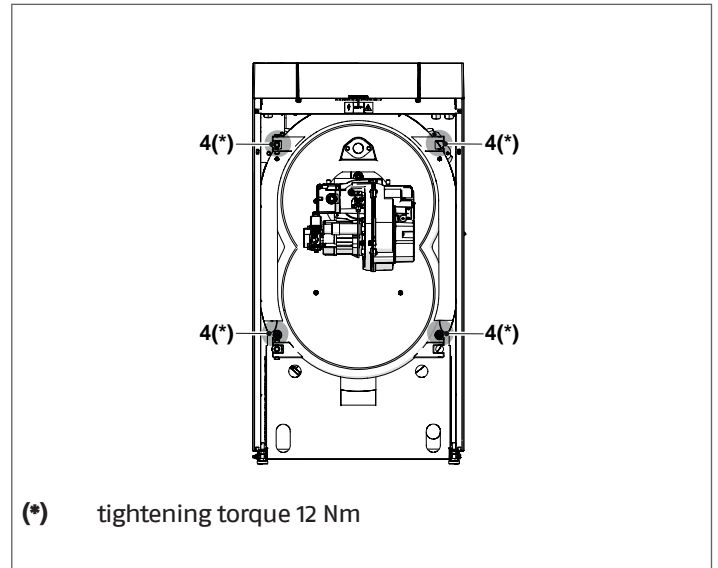

- The smoke chamber is supported on two telescopic tubes (5) that can slide outwards to facilitate cleaning operations.
- Pull out the front closure (6) of the smoke chamber completely, pulling it slowly towards you.

**⚠** During this phase, be careful not to rotate the smoke chamber as this may damage the burner or other components of the control box.

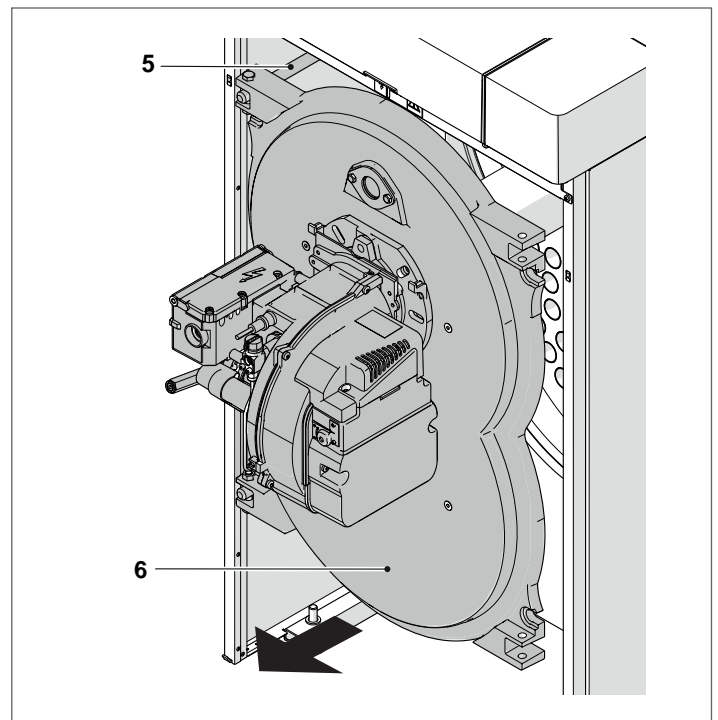

- Rotate the front closure (6) of the smoke chamber.

**⚠** Be careful not to damage the side panel of the thermal unit.

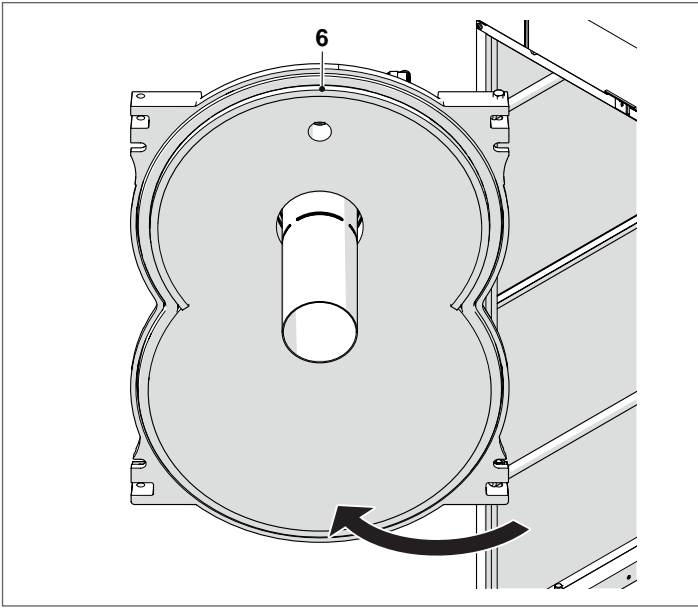

- remove the turbulators (7) and check them for wear and fin angle (replace as necessary);
- use a flue brush (8) or other suitable tool;

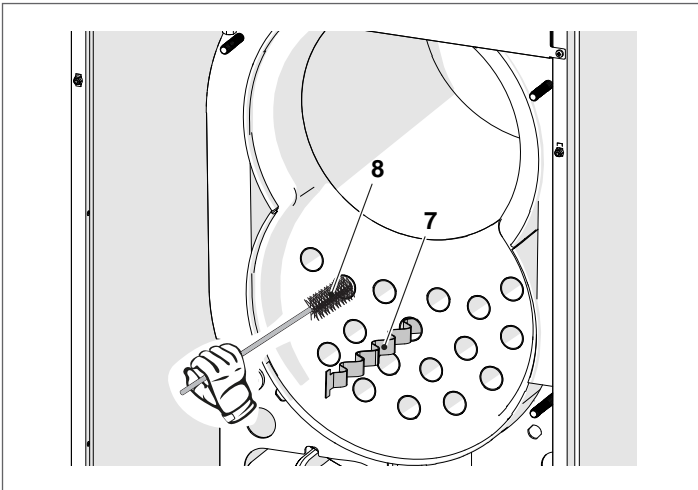

- Take out the side panel (9) by removing the fixing screw.
- Remove the deposits accumulated in the smoke box through the inspection door (10) located on the back. Check the wear status of the seal and replace it, if necessary.
- Check at regular intervals that the condensate drain (11) is not blocked.

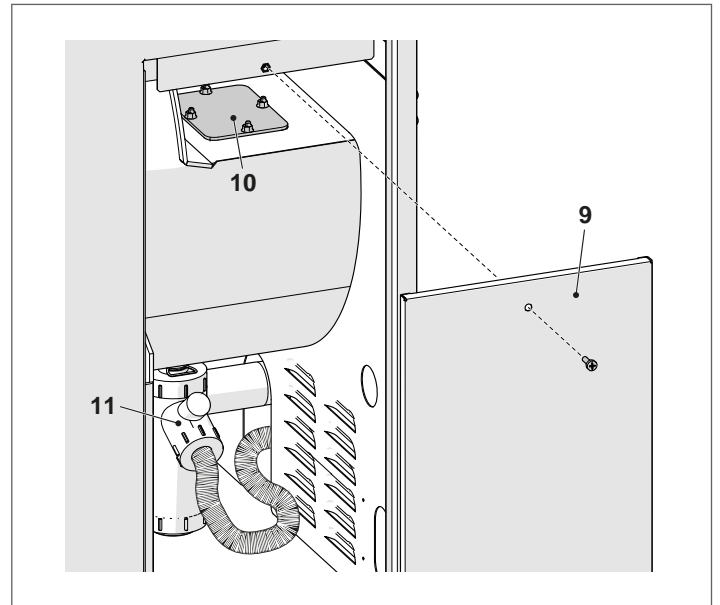

- Check the seal gasket (12) between the body of the boiler and the flue gas outlet pipes (13) is intact and replace it if necessary.

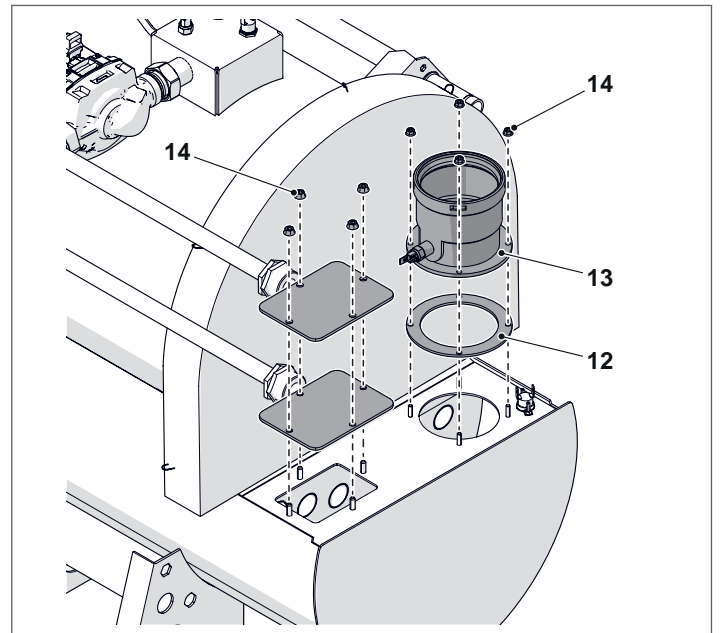

Proceed as follows on completion of cleaning:

- refit the turbulators in the flue gas pipes, making sure that they are correctly seated;
- replace all removed components in the opposite order.
- tighten the nuts (14) with a tightening torque of 4 Nm.

**⚠** Before repositioning the smoke chamber closure, replace the silicone fiberglass braided seal.

### 3.10.3 Condensate drain siphon cleaning

- Remove the front panel from the boiler and locate the condensate discharge syphon (1)

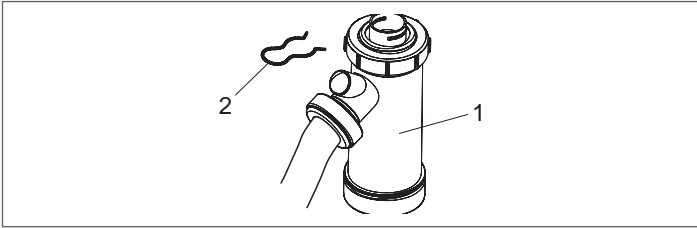

- Remove the split pin (2), detach the corrugated condensate drain hose, and remove the syphon. Unscrew the two caps (3) to disassemble the syphon
- Remove the float (4) and clean all internal components.

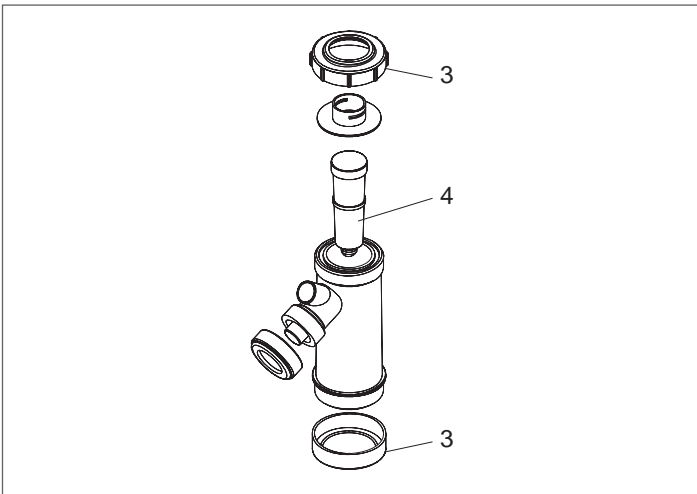

Once the maintenance operations are complete, refit the components working in the opposite direction of what was described.

- ⚠** Fill the siphon with water before you start up the boiler to prevent combustion gases escaping into the room during the first few minutes of boiler functioning.

### 3.11 External cleaning

Clean the boiler's casing panels and control panel with a soft cloth damped in soapy water.

To remove marks from the boiler casing, use a cloth damped in a 50% mix of water and denatured alcohol or a suitable cleaning product.

Wipe the boiler dry after cleaning it.

- ⊘** Do not use abrasive products, petrol or triethylene.

## 3.12 Troubleshooting

FAULT	CAUSE	SOLUTION
<b>There is a smell of fumes</b>	Fumes escaping into the air	<ul style="list-style-type: none"> <li>- Check that the burner body is clean</li> <li>- Check that the flue pipes are clean</li> <li>- Check the condition of the boiler seals</li> <li>- Check the quality of combustion</li> </ul>
<b>The boiler gets dirty very quickly</b>	Burner badly adjusted	<ul style="list-style-type: none"> <li>- Check adjustment of burner (perform flue gas analysis)</li> </ul>
	Blockage in stack	<ul style="list-style-type: none"> <li>- Clean flue pipes</li> </ul>
	Burner air intake dirty	<ul style="list-style-type: none"> <li>- Clean the burner air intake</li> </ul>
<b>The generator is at temperature but the heating system is cold</b>	Air in the circuit	<ul style="list-style-type: none"> <li>- Bleed the circuit</li> </ul>
<b>The boiler does not reach its temperature setpoint</b>	Dirt boiler body	<ul style="list-style-type: none"> <li>- Clean</li> </ul>
	Burner capacity insufficient	<ul style="list-style-type: none"> <li>- Check and adjust the burner</li> </ul>
	Boiler temperature setpoint	<ul style="list-style-type: none"> <li>- Check correct functioning</li> <li>- Check the temperature setting</li> </ul>
<b>The generator triggers a thermal safety block</b>	Safety thermostat / delivery overtemperature	<ul style="list-style-type: none"> <li>- Check correct functioning</li> <li>- Check the temperature setting</li> <li>- Check the electrical wiring</li> <li>- Check the position of the sensor bulbs</li> </ul>
	No water	<ul style="list-style-type: none"> <li>- Check the bleed valve</li> <li>- Check the heating circuit pressure</li> </ul>
<b>The safety valve keeps opening</b>	Incorrect central heating circuit pressure	<ul style="list-style-type: none"> <li>- Check the circuit pressure</li> <li>- Check pressure reducer functioning</li> <li>- Check efficiency of safety valve</li> </ul>
	System expansion reservoir	<ul style="list-style-type: none"> <li>- Check the efficiency of the expansion vessel</li> </ul>

**BURNER FAULTS/SOLUTIONS**

**SINGLE-STAGE BURNER**

Used in the model **INSIEME EVO COND 45 LN**

Problem	Diagnostic signal	Probable cause	Remedy
The burner does not ignite when heat is requested	○ OFF	No electrical power	Check voltage at L, N and in power plug Check the condition of the fuses Check that the safety thermostat has not tripped
	●● RED, GREEN flashing	The flame detector reads extraneous light	Eliminate cause of light or false flame signal
	○ OFF	The burner controller connectors are not properly plugged in	Make sure that all connectors are properly connected
	● Flashing GREEN	Short circuit connector P not connected	Replace as necessary
The burner locks out before or during pre-purging or preheating	● RED flashing	The flame detector is reading extraneous light	Eliminate cause of light or false flame signal
The burner performs pre-purging and ignition correctly but locks out after about 5 seconds	● RED Steady ON	Flame detector dirty	Clean the flame detector
		The flame detector is faulty	Change as necessary
		The flame detaches or fails	Check fuel oil pressure and flow rate
			Check the air flow Change the nozzle Check solenoid valve coil
The burner starts up only after late ignition.	○ OFF	Ignition electrodes incorrectly positioned	Adjust ignition electrodes as instructed in this manual.
		Air flow rate too high	Adjust air flow rate as instructed in this manual.
		Nozzle dirty or worn	Replace

**TWO-STAGE BURNER**

Used in the models **INSIEME EVO COND 55 LN** and **INSIEME EVO COND 70 LN**

Problem	Diagnostic signal	Probable cause	Remedy
The burner does not ignite when heat is requested	○ OFF	No electrical power	Check voltage at L, N and in power plug Check the condition of the fuses Check that the safety thermostat has not tripped
	●● ORANGE, GREEN alternate flashing	The flame detector reads extraneous light	Eliminate cause of light or false flame signal
	○ OFF	The burner controller connectors are not properly plugged in	Make sure that all connectors are properly connected
	●● RED flashing	The heater is faulty	Replace as necessary
The burner goes into lockout before or during pre-purging	●● RED flashing	The flame detector is reading extraneous light	Eliminate cause of light or false flame signal
The burner performs pre-purging and ignition correctly but locks out after about 5 seconds	●● RED	Flame detector dirty	Clean the flame detector
		The flame detector is faulty	Change as necessary
		The flame detaches or fails	Check fuel oil pressure and flow rate Check the air flow Change the nozzle Check solenoid valve coil
		Nozzle dirty or worn	Change as necessary
Yellow flame	-	Incorrect air flow	Adjust the air flow
		Pump pressure not calibrated correctly	Check the fuel pressure and flow rate and adjust it according to the instructions of this manual
		Obstructed air intake opening	Clean it
		Obstructed flue gas exhaust circuit	Clean it
Burner starts with an ignition delay	○ OFF	Ignition electrodes incorrectly positioned	Adjust ignition electrodes as instructed in this manual.
		Air flow rate too high	Adjust air flow rate as instructed in this manual.
		Nozzle dirty or worn	Replace
The burner does not switch in 2nd stage	-	The air damper opener is stuck	Check that it is working properly Check the correct electric connection
		The light oil 2nd stage valve does not activate	Faulty valve: replace it Check that the air damper opener servomotor is working properly

## 4 SYSTEM MANAGER

### 4.1 Putting into service

**⚠** The appliance must be maintained and adjusted at least once a year by Technical Assistance Service or by professionally qualified staff in compliance with all applicable National and Local provisions.

**⚠** Incorrect maintenance or adjustment may damage the appliance and cause damage to people or create a hazard.

**⚠** The system manager is forbidden from opening and removing the appliance's casing. These activities must be carried out only by Technical Assistance Service or by professionally qualified personnel.

Have **RIELLO's** Technical Assistance Service start-up your boiler for the first time. Once this has been done, the boiler can be left to function automatically.

However, the system manager may be required to restart the appliance independently, without involving Technical Assistance Service; for example after a long period of absence.

To do so, perform the following checks and operations:

- Check that the heating system's fuel shut-off valves and water valves are open

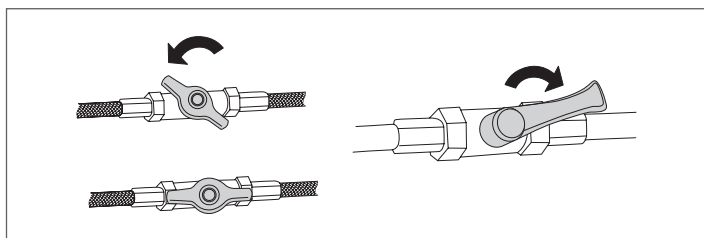

- Check that the hydraulic circuit pressure, in cool conditions, is 1.5 bar (value shown on the control panel's initial display screen) and no air is present in the circuit

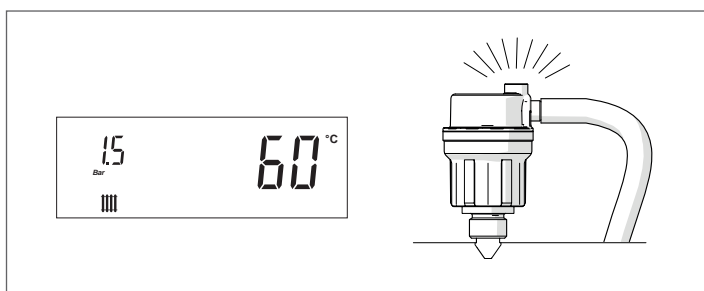

- Adjust the room thermostats for the high and low temperature zones to the required temperature (~20°C) or, if the systems are equipped with timer thermostats or a time programming unit, make sure it is on and adjusted (~20°C)

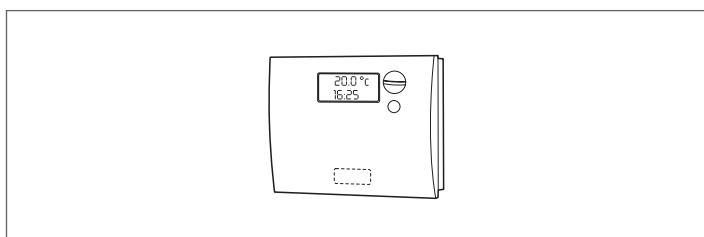

- Set the system's main switch to ON and the thermal unit's main switch to (I).

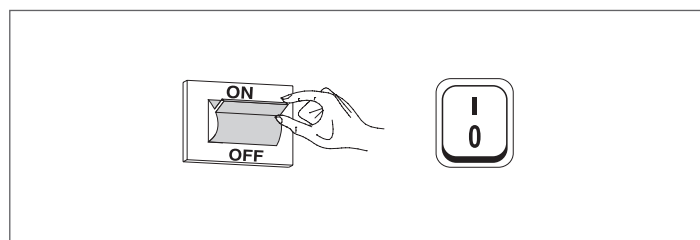

The appliance will go through the switch-on stage and, after starting, it will continue to operate until set temperatures are achieved.

The burner will then switch off and on automatically to maintain the set temperature without further operator action.

In the event of ignition or operation faults, the display will show a numeric error code that will enable the user to interpret the possible cause as detailed in Paragraph "Error List".

**⚠** In the event of a Permanent error, to reset the start-up conditions, hold down the ENTER/RESET key for 3 seconds and wait for the thermal unit to start up again.

Repeat this operation 2-3 times at the most. If the problem persists after that, call **RIELLO's** Technical Assistance Service.

## 4.2 Temporary or short-term shut-down

In the event of temporary or short-term shut-down (e.g. due to holidays), proceed as follows:

- Remove the power supply by setting the main switch of the equipment and the main switch of the system to "OFF".
- If there is a danger of frost, keep the system on. To reduce fuel consumption, set the heating set point to the minimum allowed value.

## 4.3 Preparing for extended periods of disuse

If the appliance is not going to be used for a long period of time, the following operations should be carried out: set the main switch of the system to OFF and the main switch of the equipment to (0);

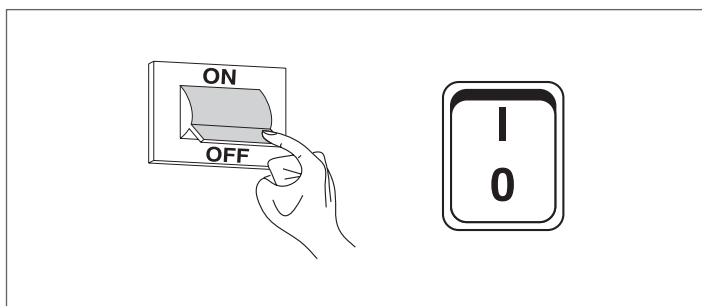

- close the fuel cock and heating circuit water cock.

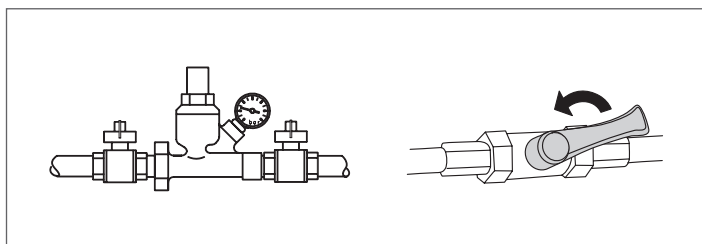

- ⚠ Drain the central heating circuit if there is any risk of freezing.

## 4.4 Cleaning

Use a cloth dampened in soapy water to clean the boiler's external casing.

To remove stubborn marks, use a cloth dampened in a 50% mix of water and denatured alcohol or a suitable cleaning product. Carefully dry after cleaning.

- ⊖ Do not use abrasive cleaning pads or powder detergents.
- ⊖ Never clean the boiler without first disconnecting it from the mains electricity supply by turning the mains power switch and the control panel switch OFF.

- ⚠ The combustion chamber and flue pipes must be cleaned periodically by the manufacturer's Technical Assistance Service or by a qualified heating engineer.

## 4.5 Maintenance

Please remember that THE PERSON RESPONSIBLE FOR SYSTEM MANAGEMENT MUST ENSURE THAT PROFESSIONALLY QUALIFIED HEATING ENGINEERS UNDERTAKE PERIODIC MAINTENANCE AND COMBUSTION EFFICIENCY MEASUREMENTS.

**RIELLO's** Technical Assistance Service is qualified to satisfy these legal requirements and can also provide useful information on MAINTENANCE PROGRAMMES designed to guarantee:

- Greater safety
- Compliance with applicable legislation
- Freedom from the risk of fines in the event of spot checks.

Regular maintenance is essential for the safety, efficiency and durability of the boiler.

Servicing is a legal requirement and must be performed at least once a year by a professionally qualified heating engineer.





## 5 RECYCLING AND DISPOSAL

The device is primarily composed of:

<b>Materiale</b>	<b>Component</b>
Metal materials	Pipework, boiler body
ABS (acrylonitrile-butadiene-styrene)	Control panel enclosure
Glass wool felt	Boiler body insulation
Electrical and electronic components	Cables and wiring, controller

At the end of the life cycle, safely remove the components and dispose of them in a responsible manner, in compliance with the installation country's applicable environmental legislation.

 Adequate sorted waste collection, processing and environmentally-friendly disposal contribute to preventing possible negative impacts on the environment and health and promote the reuse and/or recycling of the materials of which the appliance consists.

 Illegal disposal of the product by the owner shall be subject to administrative fines provided for by applicable laws.



A series of horizontal dashed lines spanning the width of the page, providing a template for writing.

# RIELLO

RIELLO S.p.A.  
Via Ing. Pilade Riello, 7  
37045 - Legnago (VR)  
[www.riello.com](http://www.riello.com)

The manufacturer strives to continuously improve all products. Appearance, dimensions, technical specifications, standard equipment and accessories are therefore liable to modification without notice.