

Wall-hung boilers



RESIDENCE HM AQUA

Wall-hung condensing boilers with stainless steel domestic hot water bi-tank

- Combined boiler with 30-liter stainless steel DHW BI-TANK
- Compact and robust stainless steel primary heat exchanger
- Simple and intuitive digital user interface
- Designed for the future to operate with blends of natural gas and hydrogen, up to a maximum of 20%.

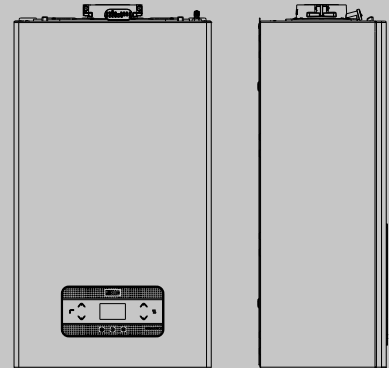

Wall-hung boilers

Wall-hung condensing boilers with DHW BI-TANK (dosseret)

RESIDENCE HM AQUA with DHW BI-TANK (dosseret)

PRODUCT DESCRIPTION

RESIDENCE HM AQUA is a condensing boiler with a 30-liter stainless steel DHW bi-tank, designed by Riello with energy savings and efficiency in mind. RESIDENCE HM AQUA consists of a system with a combi boiler of 25 or 35 kW and a domestic hot water compact bi-tank that stands out for its simplicity of installation in just two steps: installation of the DHW bi-tank on the wall and the boiler on top of it. The primary heat exchanger, made entirely of stainless steel, together with the optimized plate exchanger, ensure maximum efficiency, long-term reliability, and high comfort. Compact dimensions and an intuitive user interface complete the profile of RESIDENCE HM AQUA.

- 25 or 35 kW combi boiler with 30-litre stainless steel DHW bi-tank, available with dedicated code.
- Possibility of managing the DHW bi-tank reset frequency in Comfort and Eco mode (reduced consumption) through simple configuration of the electronics.
- Easy installation in two steps: 1. installation of the DHW bi-tank; 2. installation of the boiler on it.
- Robust, high-efficiency stainless steel condensing primary heat exchanger.
- Modern and intuitive 2.8" touchscreen user interface with illustrative icons, multilingual texts, and capacitive buttons with audible "buzzer" confirmation.
- Wide modulation range 1:10.
- IPX5D electrical protection degree.
- Hydraulic unit with standard DIN sequence connections.
- Prepared for connection with the Hi, Comfort T100 control system.
- Designed for the future to operate with blends of natural gas and hydrogen, up to a maximum of 20%.
- Gas conversion (propane air, LPG) that can be selected with electronic parameter.

TECHNICAL DATA

Description	UoM	RESIDENCE HM AQUA					
		25 BIS			35 BIS		
Gas category		I12HY20M3P			I12HY20M3P		
Country of destination		IT			IT		
Type of flue gas exhaust installation		B23P; B53P; C(10)3; C13,C13x; C33, C33x; C43, C43x; C53, C53x; C63,C63x; C83,C83x; C93,C93x			B23P; B53P; C(10); C13,C13x; C33, C33x; C43, C43x; C53, C53x; C63,C63x; C83,C83x; C93,C93x		
HEATING							
Nominal heat input (Hi)	kW	20,00			30,00		
Nominal heat output (80-60°C)	kW	19,53			29,28		
Nominal heat output (50-30°C)	kW	21,31			31,75		
Reduced thermal input (Hi)	kW	2,50	3,50	-	3,50	4,20	-
Reduced thermal output (80-60°C)	kW	2,34	-	-	3,36	-	-
Reduced thermal output (50-30°C)	kW	2,57	-	-	3,71	-	-
DHW							
Nominal heat input (Hi)	kW	25,00			34,90	32,00	-
Nominal heat output (*)	kW	25,00			34,90	-	-
Reduced thermal input (Hi)	kW	2,50	3,50	-	3,50	4,20	-
Reduced thermal output (*)	kW	2,50	-	-	3,50	-	-
Modulation ratio		1:10			1:10		
EFFICIENCY							
Useful efficiency Pn max. (80-60°C)	%	97,7			97,6		
Useful efficiency Pn min (80-60°C)	%	93,5			96,0		
Useful efficiency Pn max (50-30°C)	%	106,5			105,8		
Useful efficiency Pn min (50-30°C)	%	102,9			106,0		
Useful efficiency 30% (return 30°C)	%	109,7			109,7		
Chimney losses with burner on (Pn max.)	%	2,04			2,17		
Chimney losses with burner off	%	0,09			0,07		
Case losses with burner on (Pn max.)	%	0,30			0,20		
FLUE GASES SYSTEM							
N0x class - UNI EN 15502		6			6		
Residual head concentric flues 0,85 m Ø60-100mm	Pa	60			60		
Residual head for twin flues 0,5 m Ø80mm	Pa	180			195		
Residual head boiler without pipes Max. output	Pa	186			199		
Residual head boiler without pipes Min. power.	Pa	50			50		

Description	UoM	RESIDENCE HM AQUA					
		25 BIS			35 BIS		
ELECTRICAL CHARACTERISTICS							
Electrical power (Pel max. heating-Pel max. DHW)	W	73-87			87-110		
Burner electrical power P max.	W	44			67		
Max. circulator electrical power	W	43			43		
Min. circulator electrical power	W	4			4		
Supply voltage	V - Hz	230-50			230-50		
Degree of protection	IP	X5D			X5D		
HEATING OPERATION							
Max. pressure	bar	3			3		
Min. pressure for standard operation	bar	0,25÷0,45			0,25÷0,45		
Max. temperature	°C	90			90		
H ₂ O temperature selection range in heating.	°C	20/45 - 40/80			20/45 - 40/80		
Pump: max. head available to the system	mbar	450			450		
at an input rate of	l/h	1000			1000		
Diaphragm expansion tank	l	9			9		
Expansion tank precharge	bar	1			1		
DHW - INSTANT VERSION							
Max. pressure	bar	8			8		
Min. pressure	bar	0,5			0,5		
Hot water quantity with Dt 25°C	l/min	14,3			20		
with Dt 30°C	l/min	11,9			16,7		
with Dt 35°C	l/min	10,2			14,3		
Min. DHW input rate	l/min	2			2		
H ₂ O temperature selection range in DHW.	°C	37/60			37/60		
Flow regulator	l/min	10			14		
AIR AND FLUE GAS FLOW							
Heating		G20	G230	G31	G20	G230	G31
Air flow	Nm ³ /h	24,8	24,1	24,8	37,2	35,2	37,6
Flue gas flow	Nm ³ /h	26,8	26,5	26,4	40,2	38,7	39,9
Flue gas massive flow (max.-min.)	g/s	9,267- 1,158	9,327- 1,166	9,297- 1,162	13,900- 1,622	13,625- 1,590	14,072- 1,627
DHW							
Air flow	Nm ³ /h	31,0	30,2	31,0	43,3	40,9	43,7
Flue gas flow	Nm ³ /h	33,513	33,068	32,963	46,784	44,976	46,426
Flue gas massive flow (max.-min.)	g/s	11,584- 1,158	11,658- 1,166	11,621- 1,162	16,171- 1,622	15,851- 1,590	16,370- 1,627
EMISSION VALUES AT MAX. AND MIN. FLOW WITH GAS (**)							
Max.							
CO (dry) less than	ppm	230	200	250	240	230	240
CO ₂	%	8,8	10,0	10,0	8,8	10,3	9,9
NOx s.a. less than	ppm	40	25	50	30	30	40
Flue gas temperature	°C	79	75	78	82	71	70
Min.							
CO (dry) less than	ppm	15	20	20	15	25	20
CO ₂	%	8,8	10,0	10,0	8,8	10,3	10
NOx s.a. less than	ppm	30	25	50	30	30	40
Flue gas temperature	°C	60	66	60	60	63	57

NOTE

(*) Average value between the various operating conditions in DHW applications.

(**) Test performed with concentric flue Ø60-100 mm, length 0,85 m; water temperatures 80-60°C. The data shown must not be used to certify the system; for certification, the data indicated in the "System Booklet" measured at the time of first start-up must be used.

Wall-hung boilers

Wall-hung condensing boilers with DHW BI-TANK (dosseret)

VALUES RELATING TO DHW PERFORMANCE WITH BOILER IN THE CASE OF INSTALLATION OF THE DOSSERET KIT (AVAILABLE ON REQUEST)

		RESIDENCE HM AQUA 25 BIS	RESIDENCE HM AQUA 35 BIS
Tank type	∅	Stainless steel	Stainless steel
boiler layout	∅	Vertical	Vertical
Heat exchanger layout	∅	external plate	external plate
Vnom, actual DHW content	l	31	31
Domestic water temperature selection range	°C	37-60	37-60
Amount of water withdrawn in 10' with minimum ΔT 30°C	l	119	167
Max. operating pressure of the DHW tank	bar	10	10
Vbu, non-solar storage volume	L	31	31
Specific flow rate according to EN 13203-1 with Dt 25°C	l/min	14,3	18,1

ERP TECHNICAL DATA

Description	Symbol	UoM	RESIDENCE HM AQUA 25 BIS	RESIDENCE HM AQUA 35 BIS
Seasonal space heating energy efficiency class		D → A+++ (1)	A	A
Water heating energy efficiency class		F → A+ (2)	A	A
Nominal output	Pnominal	kW	20	29
Seasonal space heating energy efficiency class	ηs	%	94	94
USEFUL HEAT OUTPUT				
At nominal heat output and high temperature mode (*)	P4	kW	19,5	29,3
At 30% of nominal heat output and at low temperature (**)	P1	kW	6,6	9,9
EFFICIENCY				
At nominal heat output and high temperature mode (*)	η4	%	87,9	87,9
At 30% of nominal heat output and at low temperature (**)	η1	%	98,8	98,8
AUXILIARY POWER CONSUMPTION				
At full load	elmax	W	30,0	44,3
Partial load	elmin	W	12,2	13,6
In standby mode	PSB	W	3,0	3,0
OTHER PARAMETERS				
Heat loss in Standby mode	Pstby	W	30,0	35,0
Pilot flame energy consumption	Pign	W	-	-
Annual energy consumption	QHE	GJ	60	90
Indoor sound power level	LWA	dB	48	47
Nitrogen oxide emissions	NOx	mg/kWh	22	35
FOR COMBINED HEATING APPLIANCES				
Declared load profile			XL	XL
Water heating energy efficiency	ηwh	%	85	87
Daily electricity consumption	Qelec	kWh	0,173	0,102
Daily fuel consumption	Qfuel	kWh	23,014	22,524
Annual electricity consumption	AEC	kWh	38	22
Annual fuel consumption	AFC	GJ	17	17

NOTE

(*) High temperature regime: 60°C return and 80°C boiler flow.

(**) Low temperature regime: for condensing boilers 30°C, for low temperature boilers 37°C, for other heating appliances 50°C return temperature.

(1) The energy efficiency class range for this product category is between D and A+++.

(2) The energy efficiency class range for this product category is between F and A+.

For combined heating appliances: BOILER WITH DOSSERET

Description	Symbol	UoM	RESIDENCE HM AQUA 25 BIS	RESIDENCE HM AQUA 35 BIS
Load profile			XL	XL
Daily electricity consumption	Qelec	kWh	0,352	0,354
Annual electricity consumption	AEC	kWh	77	78
Water heating energy efficiency	η_{wh}	%	80	82
Daily fuel consumption	QFUEL	KWH	23,964	23,370
Annual fuel consumption	AFC	GJ	18	18

NOTE

With reference to Delegated Regulation (EU) No. 811/2013, the data shown in the table can be used to complete the product information sheet and labelling for space heaters, combi heaters, packages of space heaters, temperature control devices, and solar devices:

Component	Class	Bonus
Outdoor probe	II	2%
OT+ remote control	V	3%
Outdoor sensor + OT+ remote control	VI	4%

TABLE LAW 10

Description	UoM	RESIDENCE HM AQUA 25 BIS	RESIDENCE HM AQUA 35 BIS				
MAXIMUM THERMAL OUTPUT							
Useful (80±60°C)	kW	19,53	29,28				
Useful (50+30°C)	kW	21,31	31,75				
Combustion chamber	kW	20,00	30,00				
MINIMUM THERMAL OUTPUT							
Useful (80±60°C)	kW	2,34	3,36				
Useful (50+30°C)	kW	2,57	3,71				
Combustion chamber	kW	2,50	3,50				
EFFICIENCY							
Useful efficiency Pn max–Pn min (80±60°C)	%	97,7	97,6				
Useful efficiency Pn max–Pn min (50+30°C)	%	106,5	105,8				
Useful efficiency 30% (return 30°C)	%	109,7	108,7				
Chimney losses with burner on (Pn max.)	%	2,04	2,17				
Chimney losses with burner off	%	0,09	0,07				
Case losses with burner on (Pn max.)	%	0,3	0,2				
EMISSION VALUES AT MAX AND MIN FLOW RATE WITH GAS (*)							
Gas type		G20	G230	G31	G20	G230	G31
Max.							
CO (dry) less than	ppm	230	200	250	240	230	240
CO ₂	%	8,8	10	10	8,8	10,3	9,9
NOx s.a. less than	ppm	40	25	50	30	30	40
Flue gas temperature	°C	79	75	78	82	71	70
Min.							
CO (dry) less than	ppm	15	20	20	15	25	20
CO ₂	%	8,8	10	10	8,8	10,3	10
NOx s.a. less than	ppm	30	25	50	30	30	40
Flue gas temperature	°C	60	66	60	60	63	57
NOx class			6			6	
Electrical power: burner, circulator, total	W		73–87			87–110	

(*) Test performed with concentric flue Ø60–100 mm, length 0,85 m; water temperatures 80–60°C.

Wall-hung boilers

Wall-hung condensing boilers with DHW BI-TANK (dosseret)

DETERMINATION OF GENERATION LOSSES – CALCULATION METHOD DIRECTIVE 92/42 EEC – DATA 11300-2

PARAMETER DESCRIPTION	SYMBOL	UoM	RESIDENCE HM AQUA 25 BIS	RESIDENCE HM AQUA 35 BIS
Nominal useful thermal output	Fgn,Pn	kW	19,53	29,28
Efficiency at nominal output	hgn,pn	-	97,7	97,6
Average temperature at Pn	qgn,test,pn	°C	70	70
Useful thermal output at 30%	Fint	kW	2,50	3,50
Efficiency at 30% output	hgn,Pint	-	109,7	109,7
Average temperature at medium output	qgn,test,Pint	°C	40	40
Output loss with zero load with Dqgn,test	Fgn,1,P0	W	30	35,2
Absorbed output by auxiliaries at nominal load	Wgn,aux,Pn	W	30	44,3
Absorbed output by auxiliaries at intermediate load	Wgn,aux,Pint	W	12,2	13,6
Output consumption of auxiliaries at zero load	Wgn,aux,P0	W	3,7	3,7
Min. generator return temperature	qgn,min	°C	20	20

RESIDUAL HEAD OF THE CIRCULATOR

The boiler is equipped with a high-efficiency circulator that is already connected hydraulically and electrically, whose useful performance is indicated in the graph.

HIGH-EFFICIENCY CIRCULATOR 6M

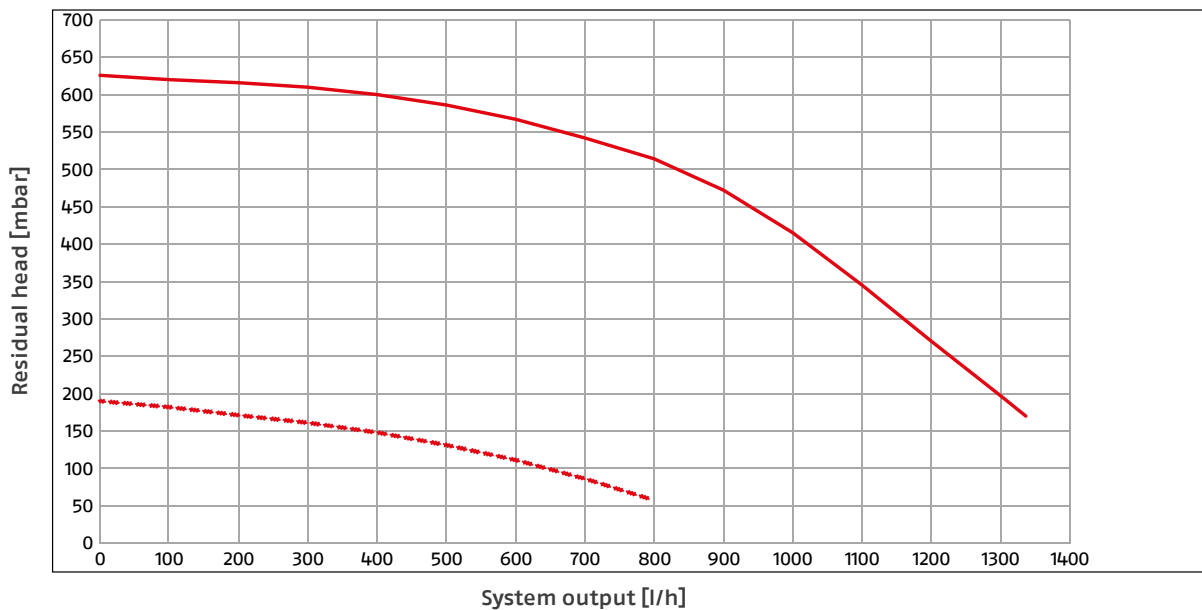

7M HIGH-EFFICIENCY CIRCULATOR (accessory)

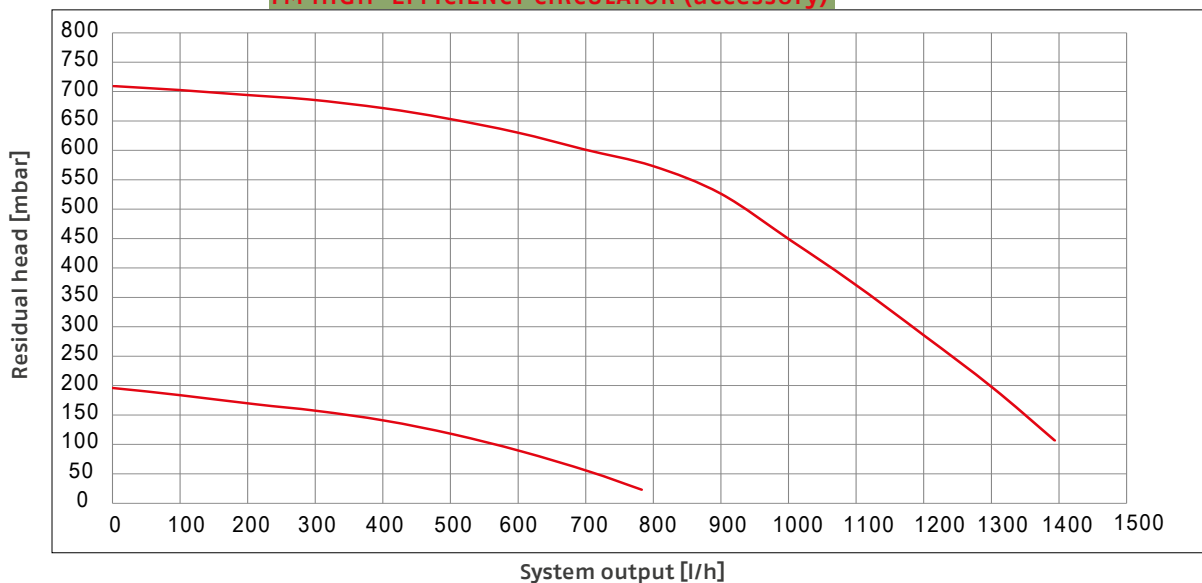

WATER CHARACTERISTICS

CHEMICAL-PHYSICAL CHARACTERISTICS

The chemical-physical characteristics of the water must comply with European standard EN 14868 and the tables below:

ALUMINUM GENERATORS WITH COMBUSTION CHAMBER OUTPUT < 150 KW

		Initial filling water	Water at operating conditions (*)
ph		-	7-8
Hardness	°F	< 15°	-
Appearance		clear	-
Iron	mg/kg	-	< 0,5
Copper	mg/kg	-	< 0,1

(*) System water values after 8 weeks of operation.

NEW HEATING SYSTEMS

The system must be filled slowly; once filled and deaerated, the system should not need to be refilled. During the first start, the system must be brought to its maximum operating temperature to facilitate deaeration (too low a temperature prevents gases to escape).

RETROFITTING OF OLD HEATING SYSTEMS

When replacing a boiler, if the water quality in existing systems complies with regulations, refilling is not recommended. If the water quality does not comply with regulations, water reconditioning or system separation is recommended (water quality requirements must be met in the boiler circuit).

OVERALL DIMENSIONS

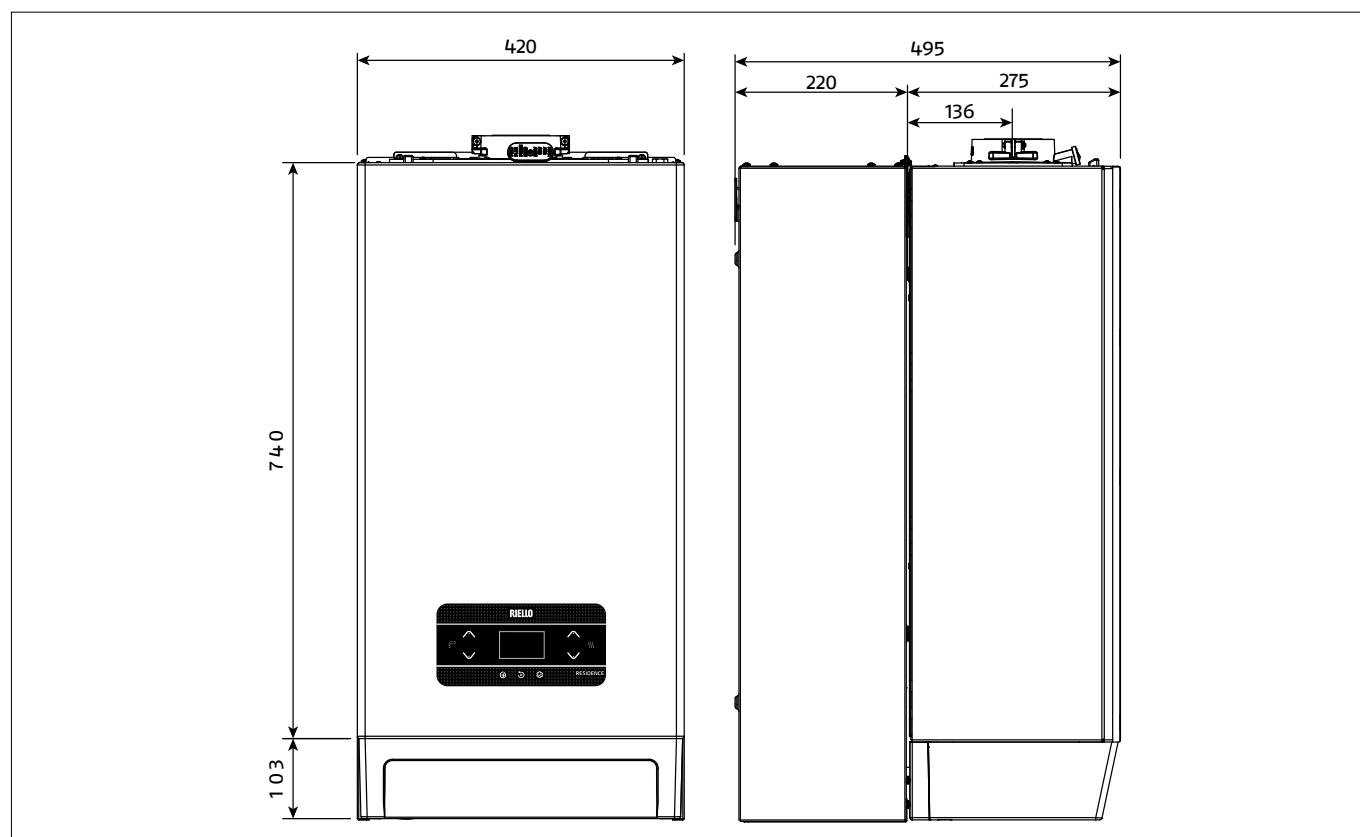

Description	UoM	RESIDENCE HM AQUA 25 BIS	RESIDENCE HM AQUA 35 BIS
Weight	kg	29	30

Wall-hung boilers

Wall-hung condensing boilers with DHW BI-TANK (dosseret)

INSTALLATION LOCATION

This type C condensing boiler is designed for heating and domestic hot water production and, depending on the type of installation, falls into two categories:

1. Type B23P-B53P boiler, forced open installation, with flue gas exhaust and combustion air intake from the room in which it is installed. If the boiler is not installed outdoors, an air intake in the installation room is mandatory;
2. Boiler type C(10)3; C13, C13x; C33, C33x; C43, C43x; C53, C53x; C63, C63x; C83, C83x; C93, C93x: sealed chamber appliance with flue gas exhaust duct and combustion air intake from outside. No air intake is required in the room where it is installed.

The appliance can be installed indoors (fig. A) or outdoors in a partially protected location (fig. B), i.e., in a place where it is not exposed to direct action and infiltration of rain, snow, or hail. The temperature range in which it can operate is: from $>0^{\circ}\text{C}$ to $+60^{\circ}\text{C}$.

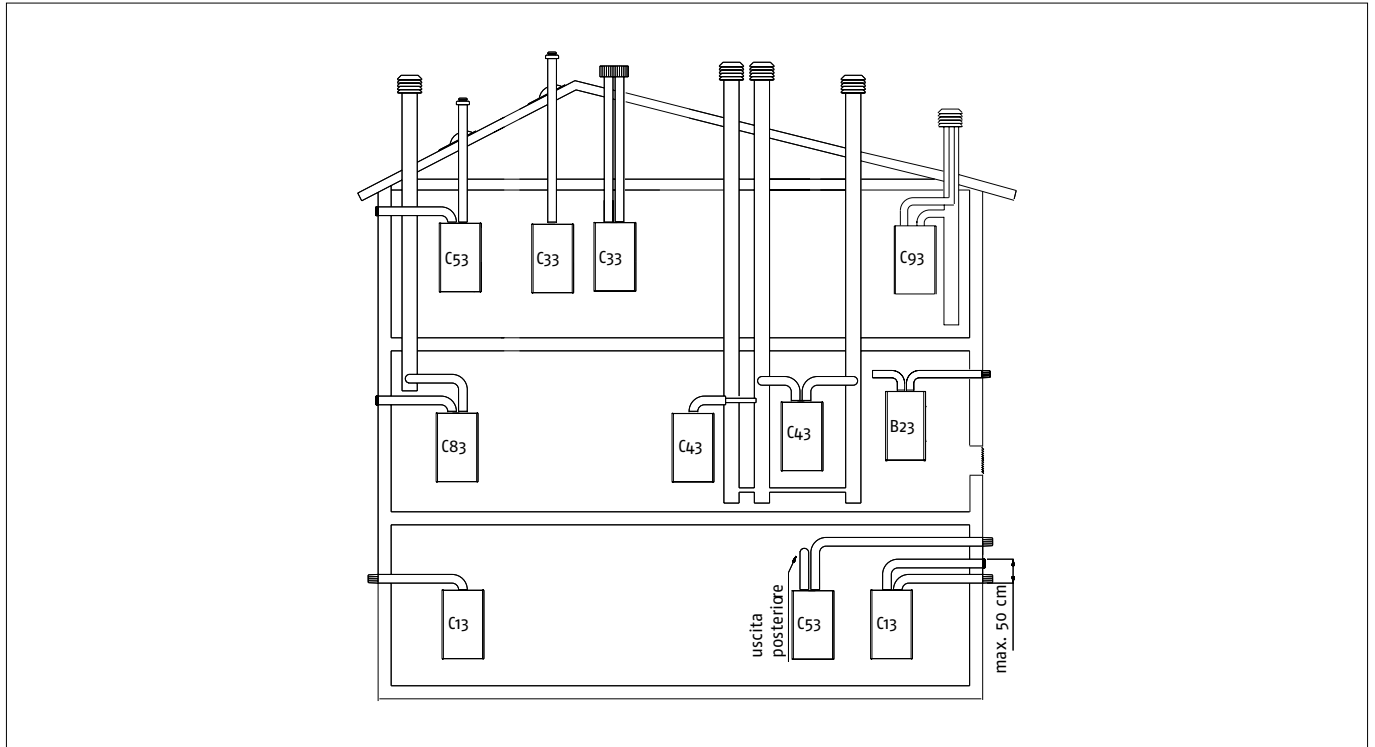

Fig. A

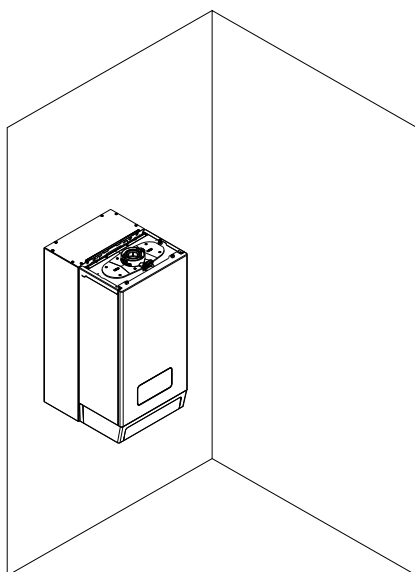
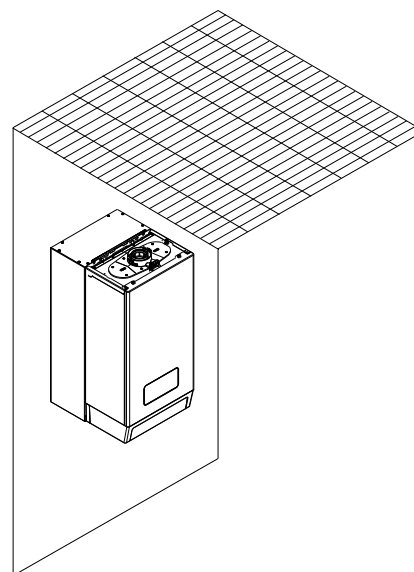

Fig. B



ANTIFREEZE SYSTEM

The boiler is equipped as standard with an automatic anti-freeze system, which is activated when the water temperature in the primary circuit falls below 5°C. This system is always active and guarantees protection of the boiler up to an air temperature at the installation site of >0°C.

NOTE: For further information, refer to the installation manual.

MINIMUM TECHNICAL SPACE REQUIREMENTS

Access the inside of the boiler for normal maintenance operations, respecting the minimum clearance required for installation.

Position the appliance, keeping in mind that:

- it must be installed on a wall capable of supporting its weight
- it must not be positioned above a stove or other cooking appliance
- it is forbidden to leave flammable substances in the room where the boiler is installed

MINIMUM TECHNICAL SPACE REQUIREMENTS FOR MAINTENANCE

The RESIDENCE HM AQUA boiler can be installed indoors in many rooms, provided that the combustion products are discharged and the combustion air is drawn from outside the room. In this case, the room does not require any ventilation openings because the boiler has a "sealed" combustion circuit with respect to the installation environment. If, on the other hand, the combustion air is taken from the installation room, the room must be equipped with ventilation openings that comply with technical standards and are of adequate size. RESIDENCE HM AQUA can be installed outdoors in a partially protected location, i.e., in a place where the boiler is not exposed to direct action and infiltration of rain, snow, or hail.

The boiler can operate in a temperature range from >0°C to +60°C.

Take into account the required clearance space for access to safety and control devices and for maintenance operations.

IMPORTANT – Before installation, it is recommended to thoroughly flush all system pipes to remove any residues that could compromise the proper functioning of the boiler.

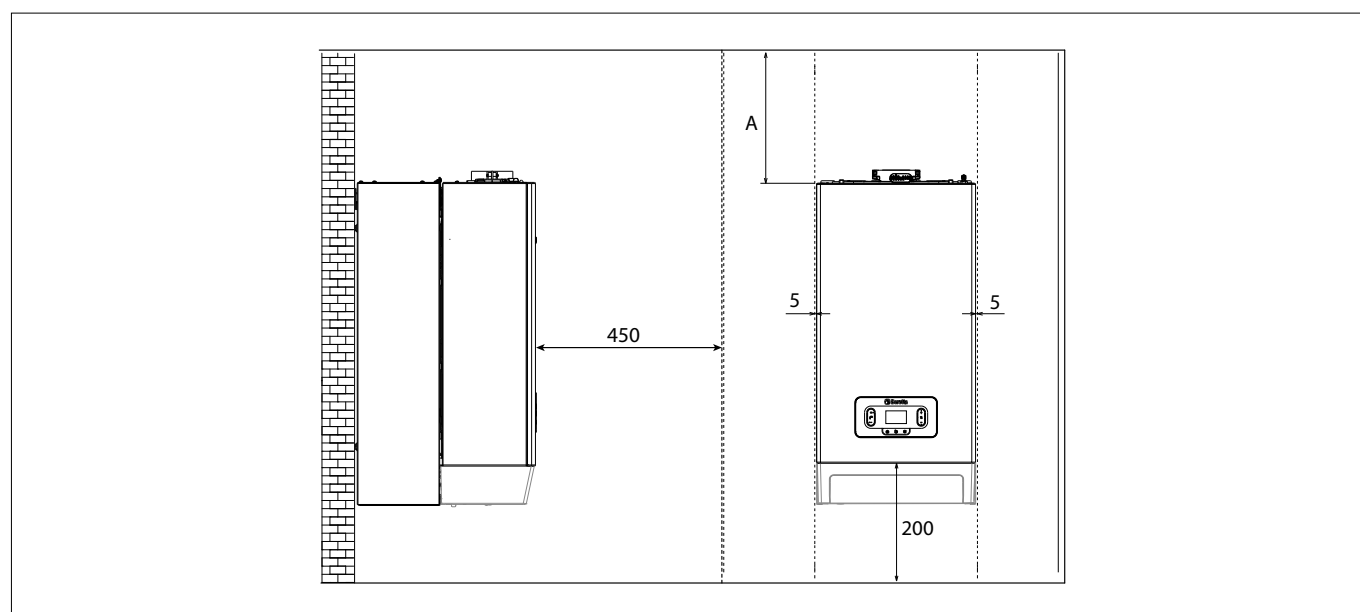

NOTE: (A) see section "Flue gas configuration" dimensions in mm

MINIMUM TECHNICAL SPACE REQUIREMENTS FOR INSTALLATION IN A CABINET

Maintain a safe distance between the wall on which the boiler is installed and the hot parts outside it.

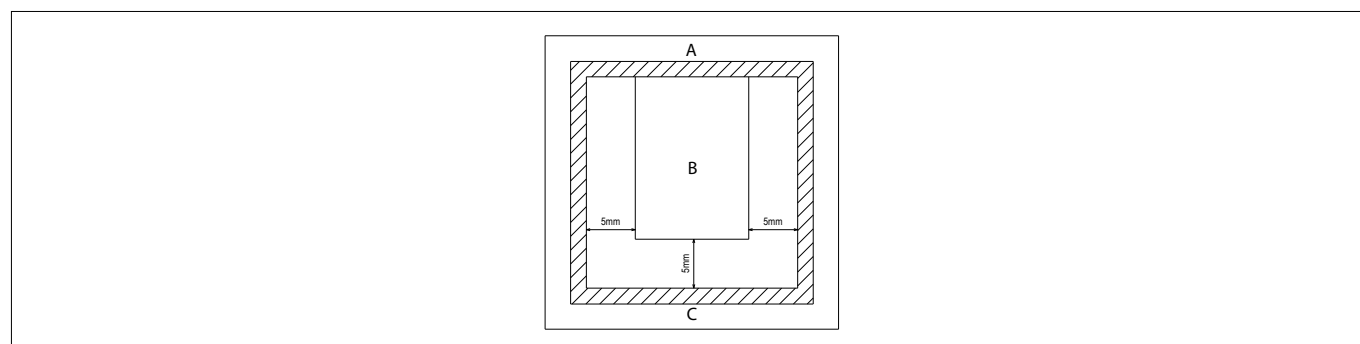

NOTE (A) Rear
(B) Top view
(C) Installation in cabinet

Wall-hung boilers

Wall-hung condensing boilers with DHW BI-TANK (dosseret)

STRUCTURE

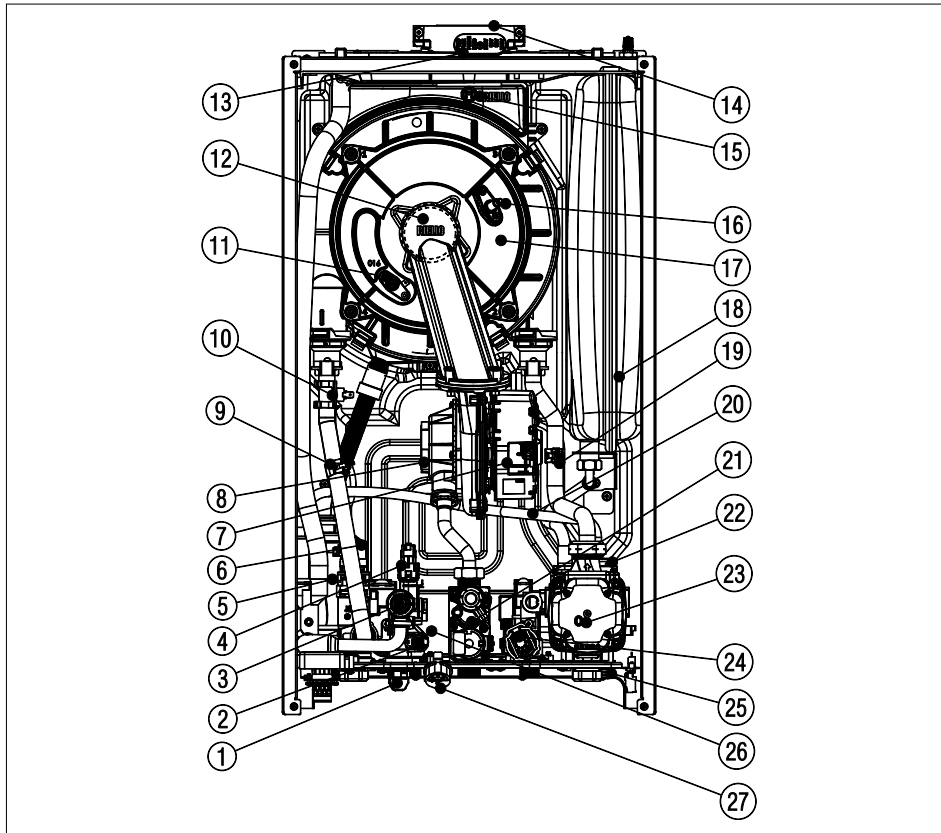

1. Filling valve
2. NTC DHW probe
3. Safety valve
4. Pressure transducer
5. Siphon
6. Three-way valve
7. Fan
8. Mixer
9. NTC flow probe
10. Limit thermostat
11. Flame detection electrode/ionization sensor
12. Burner
13. Combustion analysis test plug
14. Flue gas system
15. Flue gas probe
16. Flame ignition electrode
17. Heat exchanger
18. Expansion vessel
19. NTC return probe
20. Degassing tube
21. Gas valve
22. Air vent valve
23. Circulator
24. Flow meter
25. System drain valve
26. DHW heat exchanger
27. Water meter

DOSSERET KIT (available as accessory on request)

The Dossieret kit combined with the boiler allows you to have a reserve of water always available at the desired temperature. The system, consisting of a tank with a 30-litre water heater, is easy to install: the first step is to install the water heater on the wall, choosing the domestic water fittings that allow connection to the boiler.

Installation:

- attach the template for the wall-hung dossieret (1)
- attach the boiler fixing template to the dossieret (2)
- assemble the hydraulic pipe kit and the luxostat kit (3) (available on request)
- attach the boiler to the template (4)
- make the hydraulic connections between the dossieret and the boiler
- make the electrical connection between the dossieret and the boiler.

Refer to the specific instructions contained in the kit for further details

The boiler with DHW bi-tank technology has the same performance as boilers with 45 and 60 litre coils but with significantly reduced space requirements. It is possible, through the parameter in the electronics, to exclude the boiler function by operating the boiler in instantaneous mode, ensuring savings in gas consumption.

P5.20 = 1 boiler enabled, domestic water tank

P5.20 = 0 boiler function disabled, the boiler operates in combined mode, ensuring savings on gas consumption.

Parameter P5.21 manages the boiler reset frequency:

COMFORT causes the boiler to have longer and more frequent boiler filling cycles. This setting is recommended in domestic applications where withdrawal cycles are frequent or where the water volume demand is higher.

ECO causes the boiler to have a reduced number of boiler filling cycles. This option should be selected when greater energy savings are desired.

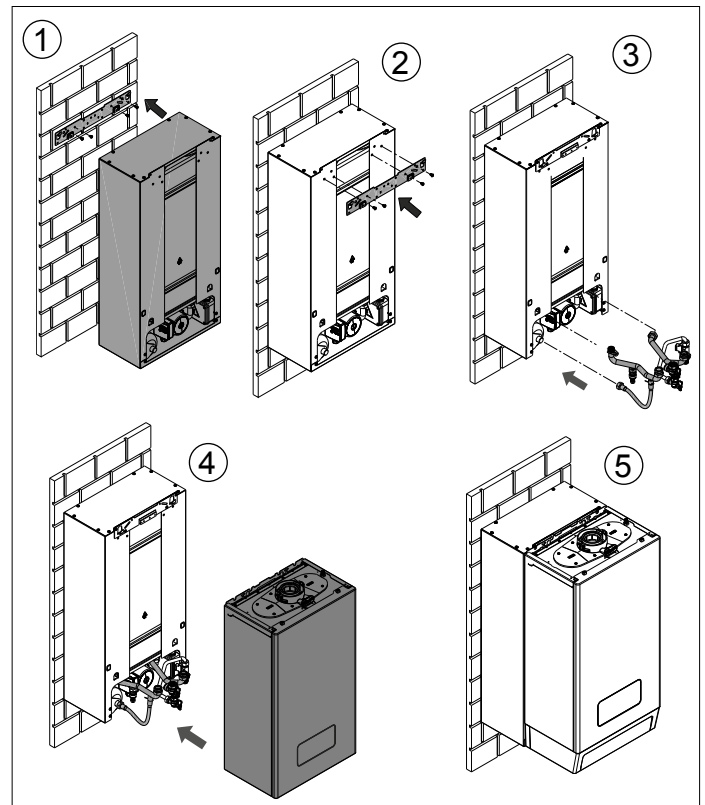

INSTALLATION DIAGRAM AND HYDRAULIC CONNECTIONS

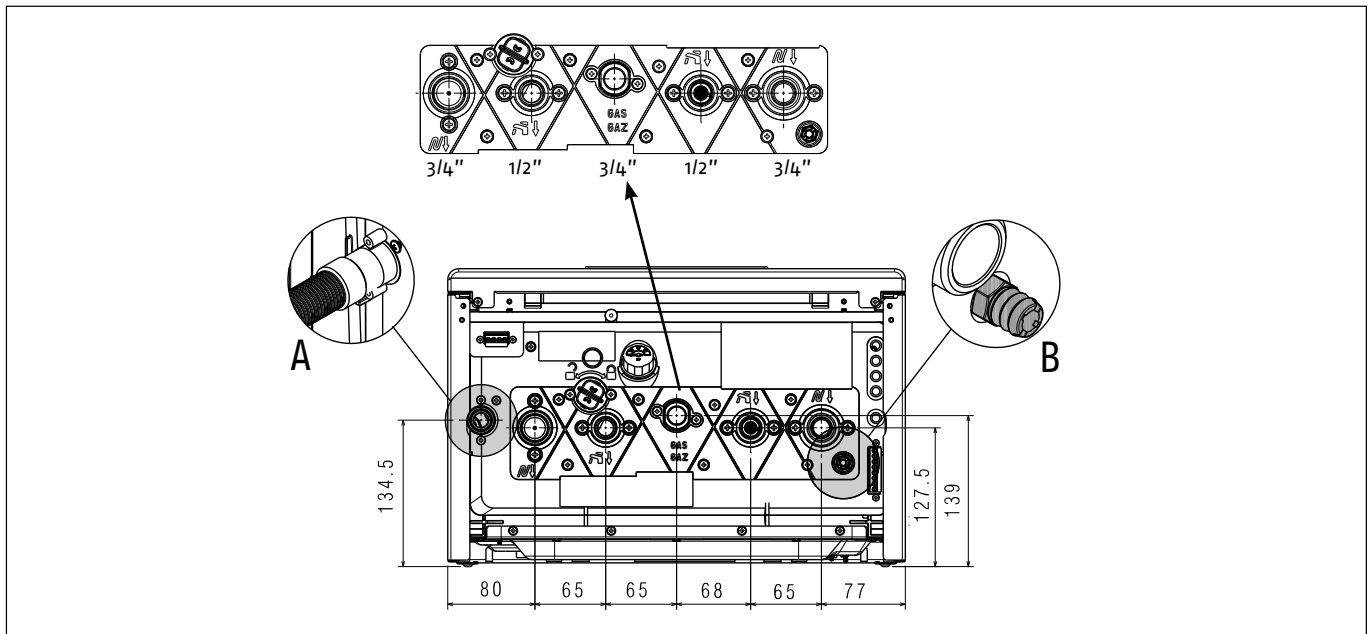

- (A) Safety valve siphon drain
- (B) system drain tap

Description	Gasket	Torque wrench
Tightening torque	Ø 3/4"	35Nm
Tightening torque	Ø 1/2"	25Nm

HYDRAULIC CIRCUIT

REF.	DESCRIPTION
R	Heating return
M	Heating flow
AC	Hot water
AF	Cold water
1	Safety valve
2	Safety valve
3	Hydraulic three-way valve
4	Pressure transducer
5	Automatic bypass
6	Flow probe
7	Limit thermostat
8	Primary heat exchanger
9	Return probe
10	Lower air vent valve
11	Expansion vessel
12	Circulator
13	System drain valve
14	Non-return valve
15	DHW heat exchanger
16	Water meter
17	DHW probe
18	Flow limiter
19	Flow meter
20	DHW filter

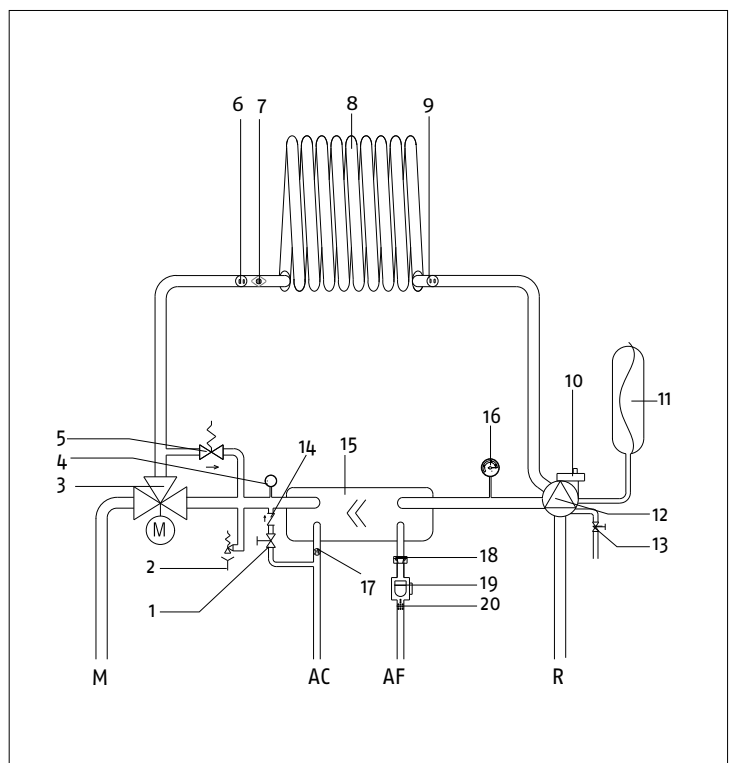

Wall-hung boilers

Wall-hung condensing boilers with DHW BI-TANK (dosseret)

ELECTRICAL CONNECTIONS

Access to electrical side

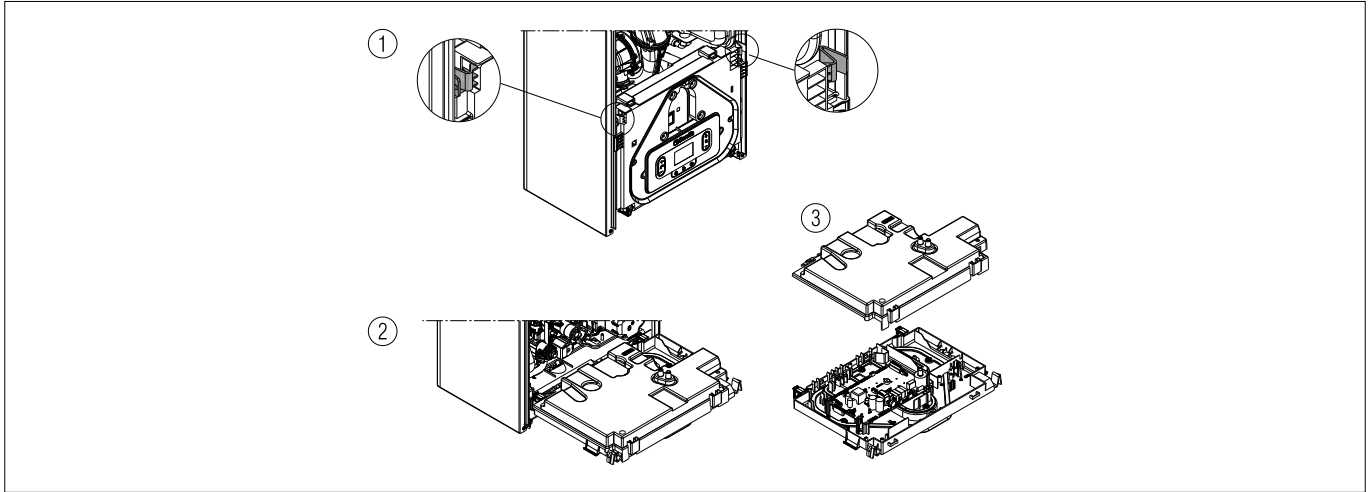

Perform the low voltage electrical connections as follows:

- use the connectors supplied:
- 4-pole ModBus connector for BUS 485 signal (- A B +).
- 8-pin connector for TBT – TA –OT+ – SE signals.

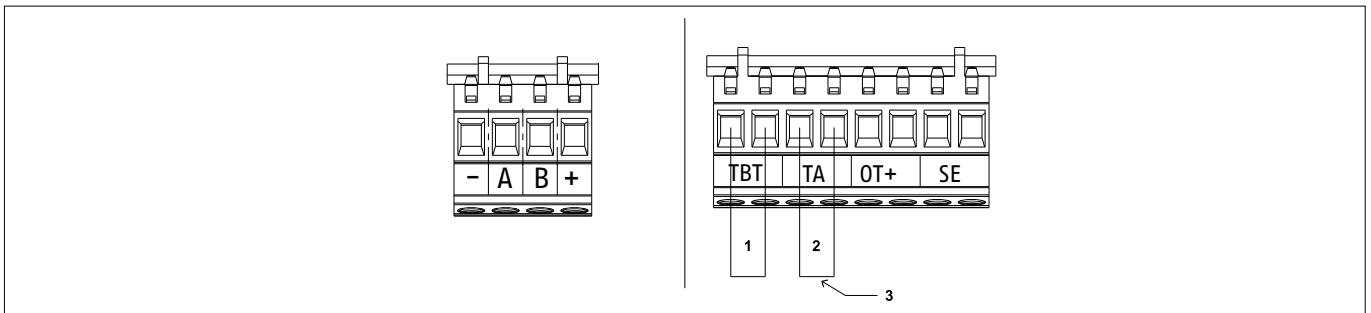

Legend

CE4	(- AB+)	485 bus.
CE8	TBT	Low temperature thermostat.
	TA	Room thermostat (voltage-free contact).
	OT+	Open therm.
	SE	Outdoor probe.

NOTE (1) White.
(2) Black.
(3) Use voltage-free contact.

- Make the electrical connections using the desired connector as shown in the detailed drawing.
- Once the electrical connections have been made, insert the connector correctly into its counterpart.

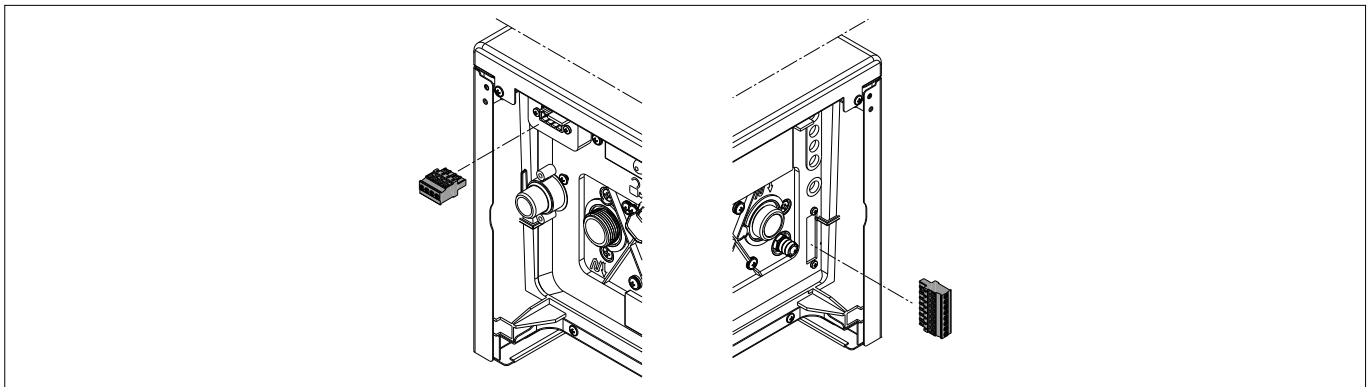



We recommend using conductors with a minimum wire cross-section of 0,35mm² and a maximum of 1,5mm².





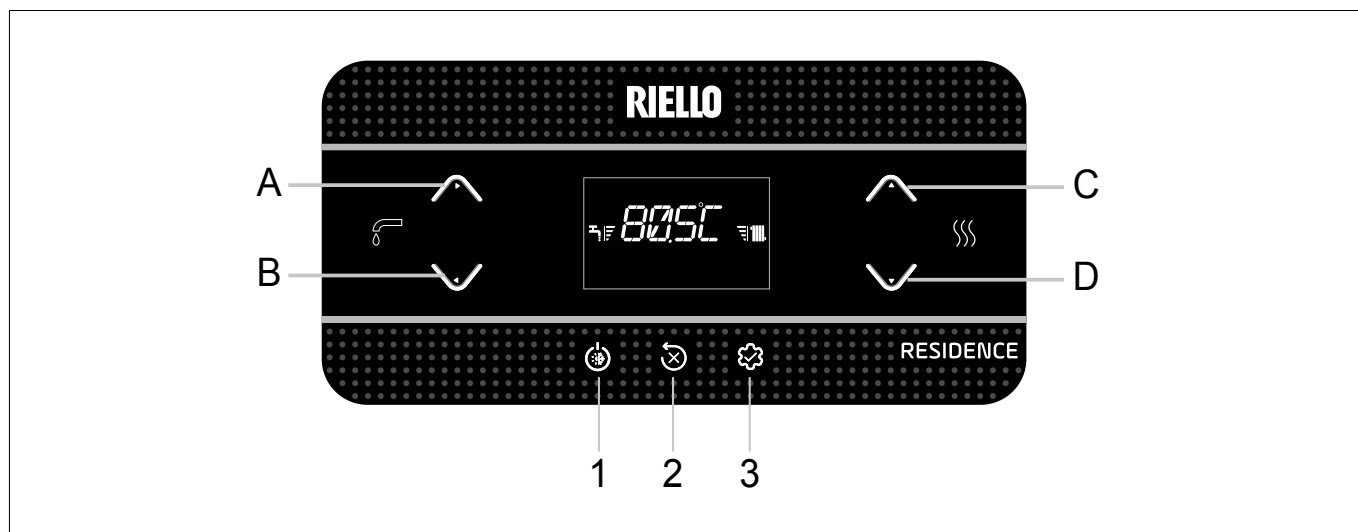















For the BUS 485 connection, we recommend using shielded cable if the signal passes close to other electrical conductors or mains voltage conductors (230V).

In the case of TA or TBT connections, remove the relevant jumpers from the terminal block.

CONTROL PANEL



Key functions	
A	It is normally used to increase the domestic hot water temperature value; when the arrow is highlighted ► it performs the confirmation function.
B	It is normally used to decrease the domestic hot water temperature value when the arrow is highlighted ◀ it performs the back/cancel function.
C+D	Manual heating time programming
C	It is normally used to increase the heating water temperature value; when the arrow is highlighted ▲ it allows you to move within the P1 menu.
D	It is normally used to decrease the heating water temperature value; when the arrow is highlighted ▼ it allows you to move within the P1 menu.
A+C	Access to the clock settings menu.
B+D	Time programming
1	Used to change the boiler operating status (OFF, SUMMER, and WINTER).
2	Used to reset the alarm status or to interrupt the venting cycle.
3	Used to access the menus. INFO and P1 . When the icon  is displayed on the screen, the button acts as ENTER and is used to confirm the value set when programming a technical parameter.
1+3	Key lock and unlock.
2+3	When the boiler is in the OFF state, it is used to activate the combustion analysis (CO) function.

Description of icons	
	Indicates connection to a remote device (OTBus or RS485)
	Indicates connection to a WIFI device.
	Indicates the presence of an external probe.
	Indicates the activation of special domestic hot water functions.
	Icon that lights up in the event of an alarm.
	Lights up in the event of a fault together with the icon  , except for flame and water alarms.
	Indicates the presence of a flame; in the event of a flame block, the icon appears 
	Flashes with temporary water alarms, stays lit with permanent alarms
	Lights up in the presence of alarms that require manual unlocking by the operator.
	It lights up when a confirmation operation is required.
	When the icon is active, it indicates that the "confirm" function of button A is active.
	When the icon is active, it indicates that the "back/cancel" function of key B is active.
	When the icon is active, you can navigate the menu or increase the value of the selected parameter.
	When the icon is active, you can navigate the menu or decrease the value of the selected parameter.
	The icon lights up if heating is active and flashes if a heating request is in progress.
	The icon lights up when domestic hot water is active and flashes when a domestic hot water request is in progress.
	These indicate the setpoint level (1 = minimum value, 4 = maximum value).
	1 2 3 4 5 6 7
AUTO 	Not available on this model.
MAN ON	Not available on this model.
MAN OFF	Not available on this model.

Wall-hung boilers

Wall-hung condensing boilers with DHW BI-TANK (dosseret)

FLUE GAS DISCHARGE AND COMBUSTION AIR INTAKE

For the evacuation of combustion products, refer to the UNI7129-7131 standard.

You must also always comply with local fire department regulations, gas company regulations, and any municipal regulations.

It is essential for the extraction of flue gases and the supply of combustion air to the boiler that only original pipes are used (except type C6, provided they are certified) and that the connection is made correctly as indicated in the instructions provided with the flue gas accessories.

Multiple appliances can be connected to a single flue, provided that they are all condensing type.

For maximum lengths and pressure drops, refer to the 'Flue gas system configuration table'.

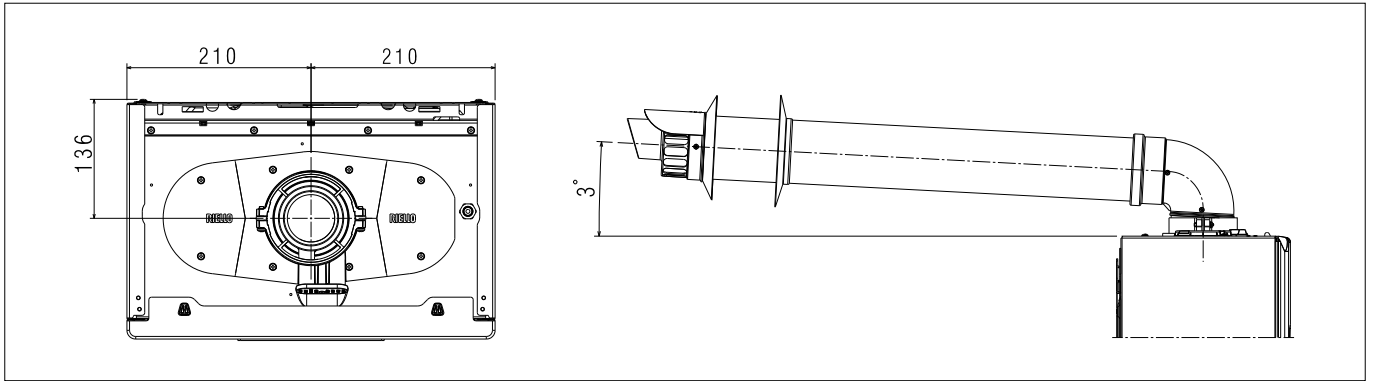

FLUE GAS SYSTEM CONFIGURATION

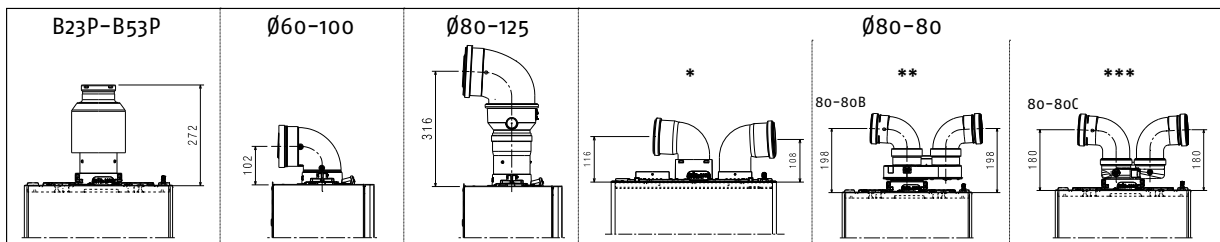

* Ø80 fixed twin flue kit



** Adjustable twin pipe kit from Ø60/100 to Ø80/80

*** Compact adjustable twin flue kit from Ø60-100 to Ø80-80

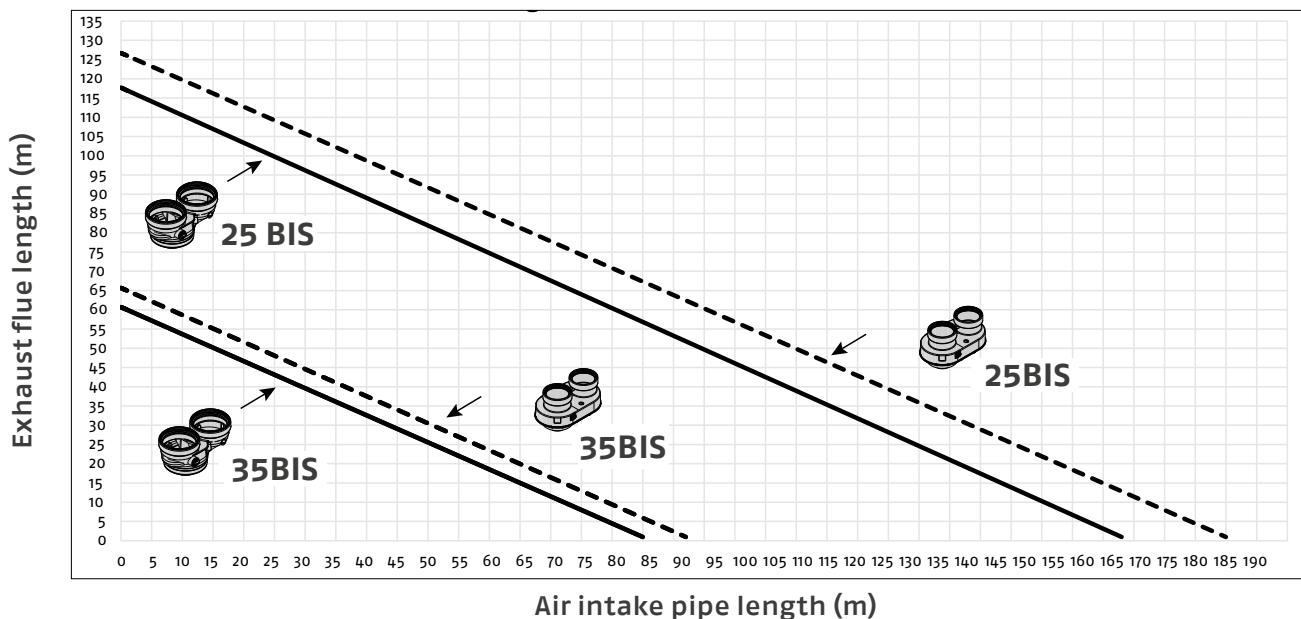





MAXIMUM PIPE LENGTH Ø80-80 MM



Note: use the dotted line when using the adjustable twin flue kit from Ø60-100 to Ø80-80 and the fixed twin flue kit, or the solid line when using the compact adjustable twin flue kit from Ø60-100 to Ø80-80

Image	Description
	Adjustable twin flue kit from Ø60/100 to Ø80/80
	Ø80 fixed twin flue kit
	Compact adjustable twin flue kit from Ø60-100 to Ø80-80

Flue gas system configuration table

Image	Flue gas type	Diameter (Ø - mm)	25 BIS		35 BIS		Pressure drop		Wall passage hole (Ø - mm)				
			MAX. length (m)	MIN. length (m)	MAX. length (m)	MIN. length (m)	45° bend	90° bend					
	vertical connection from Ø60-100 to Ø80	80	120	0,50	60	0,50	1	1,5	-				
	Ø60-100, 90° bend	60-100	horizontal	10	horizontal	0,85	horizontal	10	horizontal	0,85	1,3	1,6	105
			vertical	11	vertical	2	vertical	11	vertical	2			
	Ø80-125, 90° bend adapter from Ø60-100 to Ø80-125 adapter for vertical connection Ø60-100	80-125	25	0,85	20	0,85	1	1,5	130				
	Adjustable twin flue kit from Ø60-100 to Ø80-80	80-80	75+75	0,50	39+39	0,50	1	1,5	-				
	Ø80 fixed twin flue kit												
	Compact adjustable twin flue kit from Ø60-100 to Ø80-80	80-80	69+69	0,50	36+36	0,50	1	1,5	-				

TWIN FLUE Ø80 WITH Ø50 - Ø60 - Ø80 INSIDE CHIMNEY (*)

The boiler characteristics allow the connection of the Ø80 flue gas exhaust duct to the Ø50 - Ø60 - Ø80 ducting system.
Warning - For the ducting system, it is recommended to perform a design calculation in order to comply with current regulations.
The table shows the basic configurations of the permitted flue outlet.

TABLE OF BASIC FLUE OUTLET CONFIGURATIONS (*)

Air intake	Ø80, 90° bend
	Ø80, 4,5 m extension
Flue gas system	Ø80, 90° bend
	Ø80, 4,5 m extension
	Reduction from Ø80 to Ø50 from Ø80 to Ø60
	Ø50 or Ø60 or Ø80, 90° base chimney bend
For flue gas lengths, see table	

TWIN SYSTEM USING THE Ø80 TWIN SYSTEM CONNECTION KIT (ACCESSORY)





If the Ø60-100 to Ø80-80 twin system kit is used instead of the twin system, there will be a loss in maximum lengths as indicated in the table.

TWIN PIPE KIT	UoM	Ø50	Ø60	Ø80
Loss of length	m	0,5	1,2	5,5 for flue outlet 7,5 for air outlet

Wall-hung boilers

Wall-hung condensing boilers with DHW BI-TANK (dosseret)

BOILERS LEAVE THE FACTORY CALIBRATED TO:

		rpm HEATING	rpm DHW	Maximum flue gas length (m)		
				Ø50	Ø60	Ø80
25 BIS		6300	7900	7	23	116
				6	20	98
35 BIS		7400	8600	2	12	62
				1	11	57

If greater lengths are required, compensate for pressure drops by increasing the fan speed as shown in the adjustment table to ensure the rated heat output.

The minimum calibration must not be changed.

BOILERS LEAVE THE FACTORY CALIBRATED TO:



Adjustable twin flue kit from Ø60-100 to Ø80-80

	Fan speed rpm		Ø50	Ø60	Ø80	ΔP boiler outlet
	Heating	DHW				
25 BIS	Maximum length (m)					
	6300	7900	7	23	116	180
	6400	8000	9*	29*	144*	210*
	6500	8100	11*	34*	172*	257*
	6600	8200	14*	40*	201*	285*
	6700	8300	16*	46*	229*	330*
	6800	8400	18*	51*	257*	355*
	6900	8500	21*	57*	285*	385*
	7000	8600	23*	63*	314*	425*
	7100	8700	25*	68*	342*	465*
35 BIS	7200	8800	28*	74*	370*	497*
	7400	8600	2	12	62	195
	7500	8700	4*	18*	92*	242*
	7600	8800	6*	24*	119*	289*
	7700	8900	9*	29*	145*	337*
	7800	9000	11*	34*	172*	384*

NOTE: (*) Maximum length that can be installed ONLY with class H1 exhaust flue gas system.

Compact adjustable twin flue kit from $\varnothing 60-100$ to $\varnothing 80-80$

	Fan speed rpm		$\varnothing 50$	$\varnothing 60$	$\varnothing 80$	ΔP boiler outlet
	Heating	DHW				
25 BIS	Maximum length (m)					
	6300	7900	6	20	98	170
	6400	8000	8*	25*	124*	203*
	6500	8100	10*	30*	150*	235*
	6600	8200	13*	35*	176*	268*
	6700	8300	15*	40*	202*	300*
	6800	8400	17*	46*	228*	333*
	6900	8500	19*	51*	253*	365*
	7000	8600	21*	56*	279*	398*
	7100	8700	23*	61*	305*	430*
35 BIS	7200	8800	25*	66*	331*	463*
	7400	8600	1	11	57	180
	7500	8700	3*	17*	84*	227*
	7600	8800	6*	22*	111*	274*
	7700	8900	8*	28*	138*	322*
	7800	9000	10*	33*	165*	369*

NOTE: (*)Maximum length that can be installed ONLY with class H1 exhaust flue gas system.

The $\varnothing 50$, $\varnothing 60$, and $\varnothing 80$ configurations show experimental data verified in the laboratory. For installations that differ from those indicated in the "basic configurations" and "adjustments" tables, refer to the equivalent linear lengths shown below and to the graph. In any case, the maximum lengths stated in the manual are guaranteed and it is essential not to exceed them.

Component	Linear equivalent in meters $\varnothing 80$ (m)	
	$\varnothing 50$	$\varnothing 60$
45° bend	12,3	5
90° bend	19,6	8
0,5 m extension	6,1	2,5
1,0 m extension	13,5	5,5
2,0 m extension	29,5	12

For special configurations, once the equivalent linear length has been calculated with reference to the $\varnothing 80$ mm for the flue gas outlet, check the chart (Maximum flue length of $\varnothing 80-80$ mm) for the maximum extension for the air pipe and flue gas system.

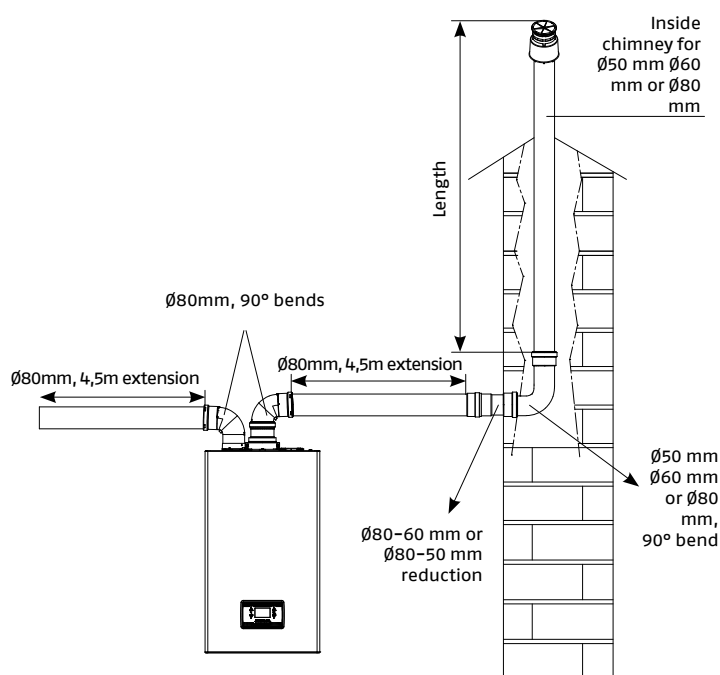

Wall-hung boilers

Wall-hung condensing boilers with DHW BI-TANK (dosseret)

DHW BI-TANK (DOSSERET – ACCESSORY)

STRUCTURE

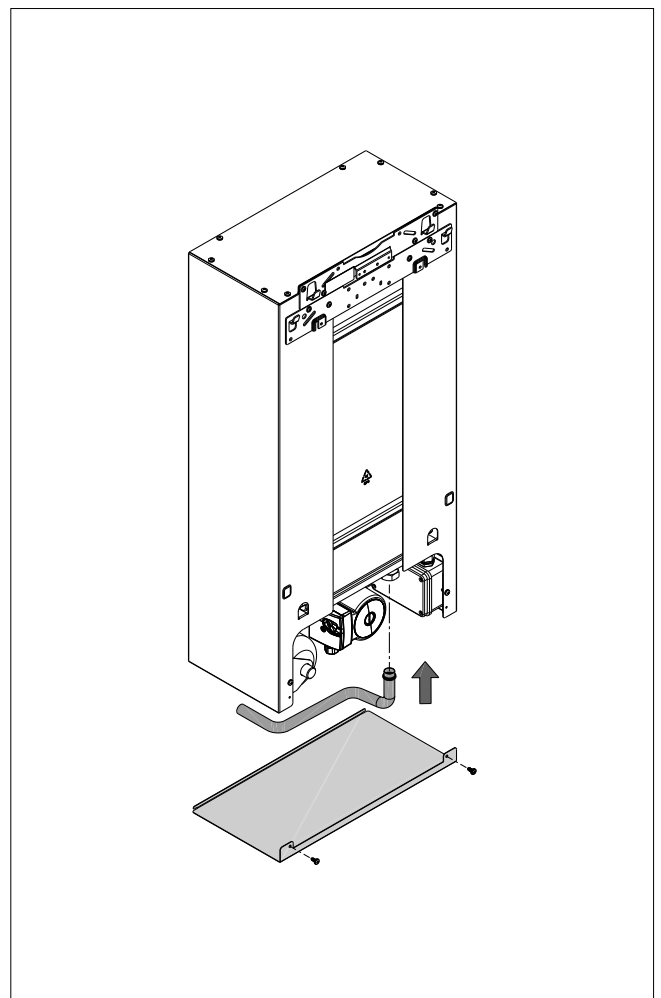
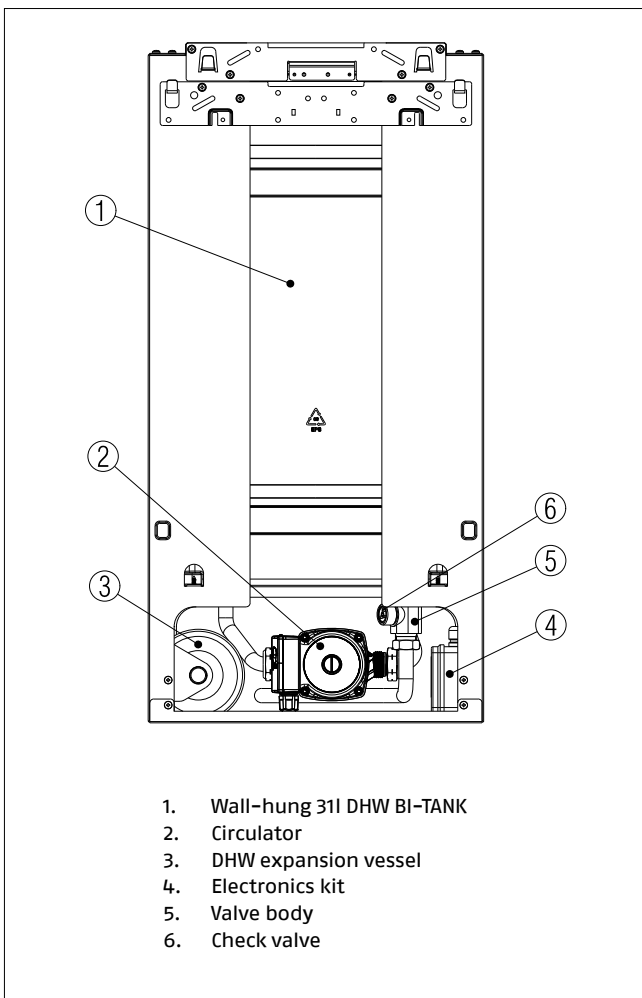
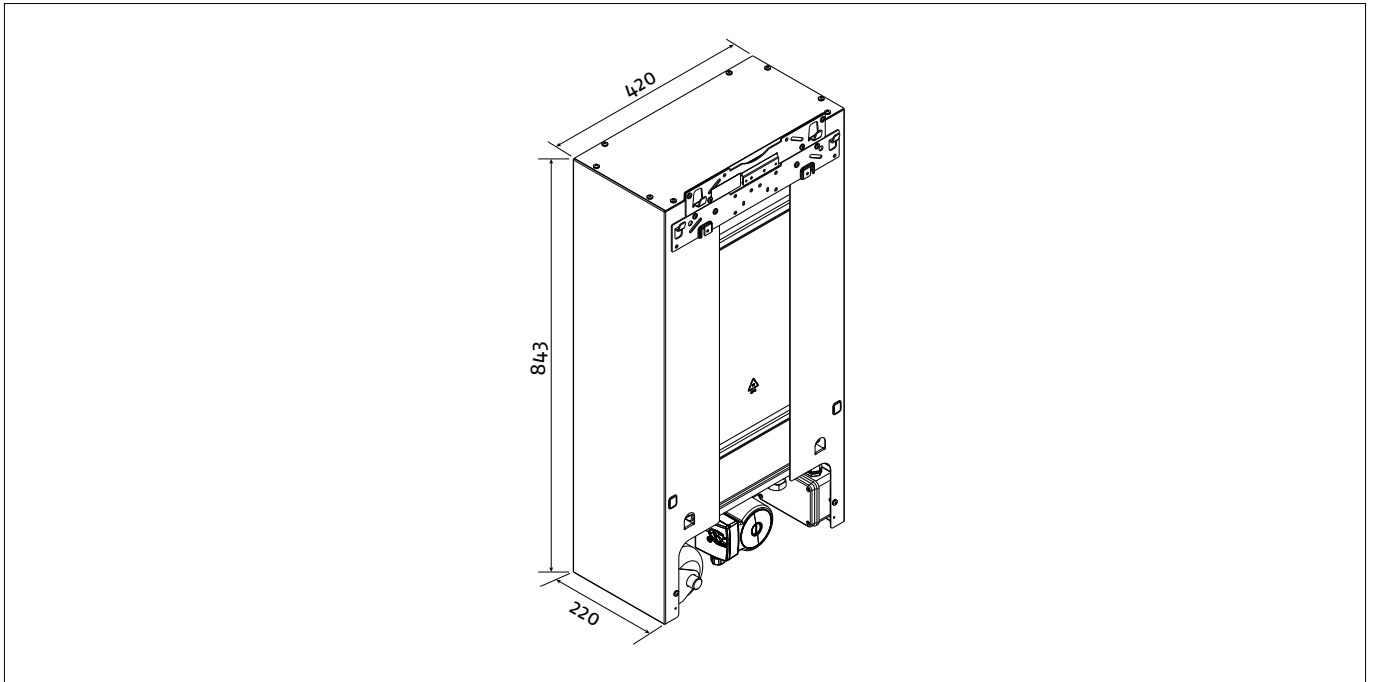

ELECTRICAL DIAGRAM

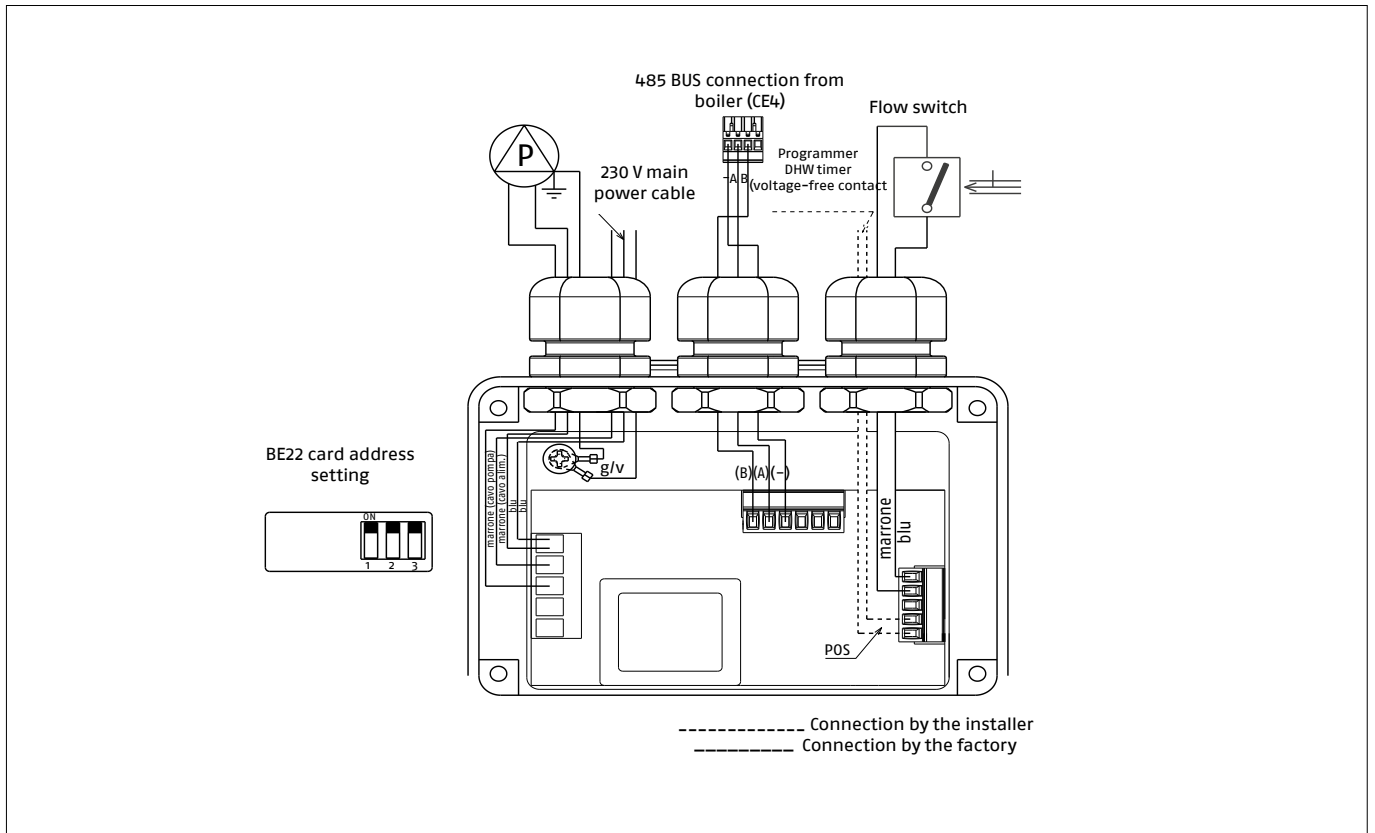

HYDRAULIC CIRCUIT

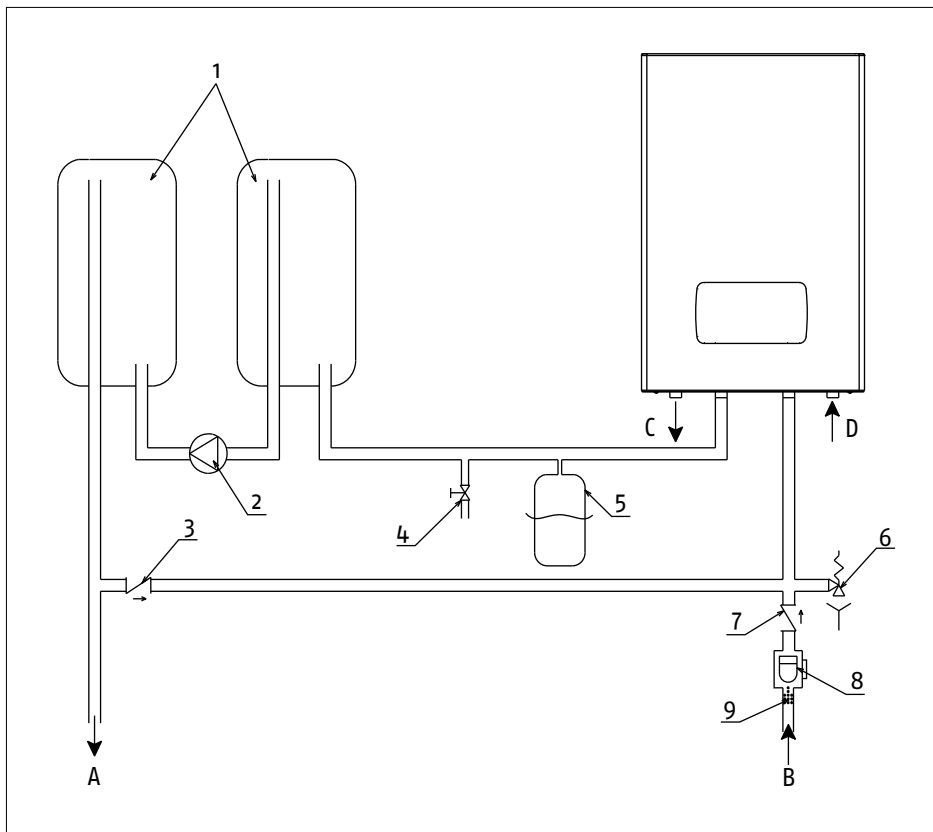

REF.	DESCRIPTION
A	Hot water outlet
B	Cold water inlet
C	Heating flow
D	Heating return
1	Wall-hung 31 I BI-TANK
2	DHW pump
3	Check valve
4	Drain tap
5	DHW expansion tank
6	Safety valve
7	Check valve
8	Flow switch
9	DHW filter

Wall-hung boilers

Wall-hung condensing boilers with DHW BI-TANK (dosseret)

INSTALLATION

DHW BI-TANK + RESIDENCE AQUA 25 BIS

1

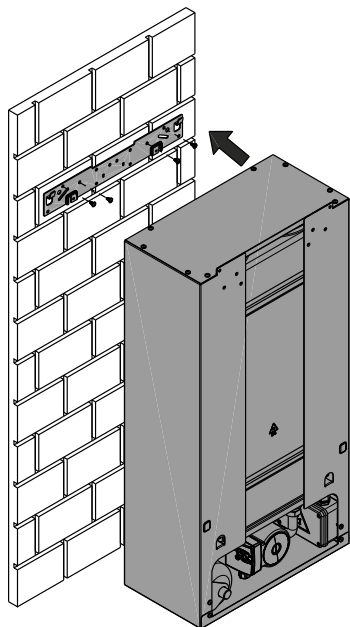

2

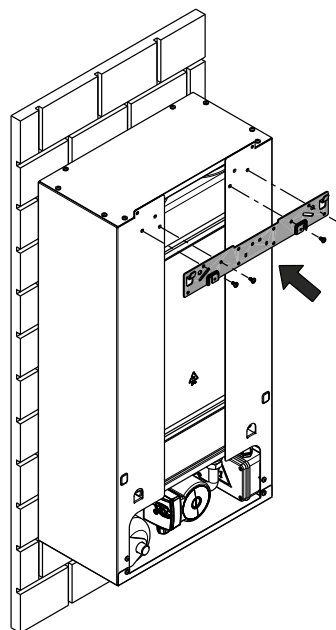

3

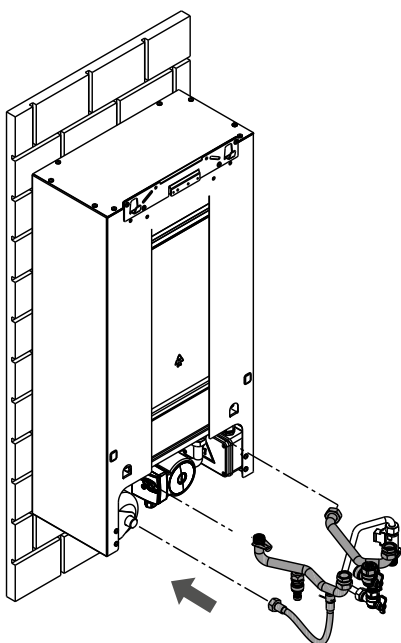

4

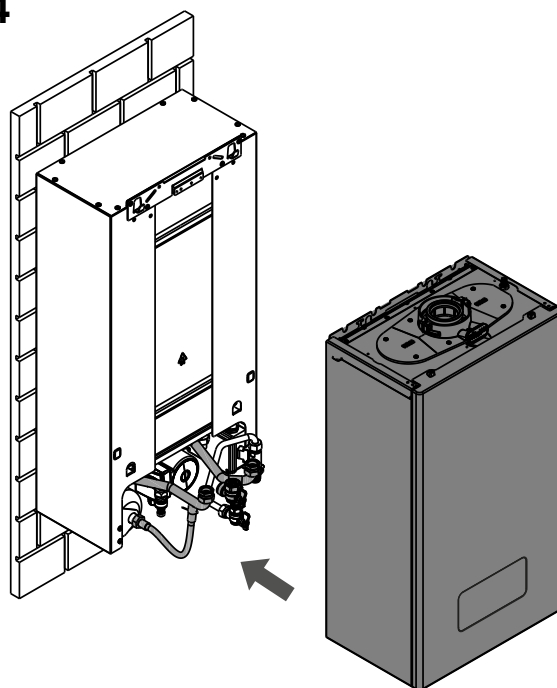

ELECTRICAL CONNECTIONS

Factory configuration – CIRCULATOR CONNECTION

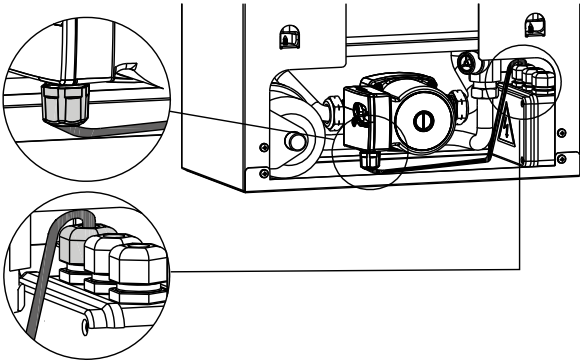

Remove the 4-way connector located under the boiler shelf

Factory configuration – FLOW SWITCH CONNECTION

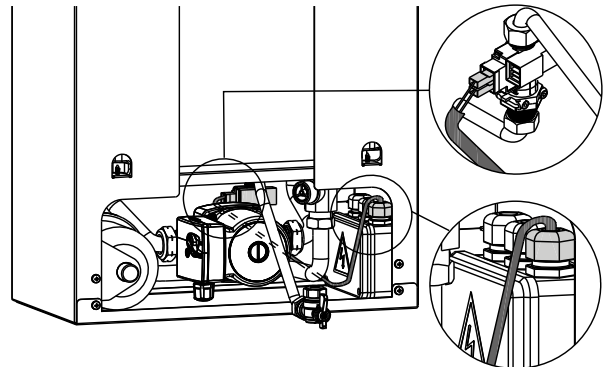

Connect the BUS 485 signal cable

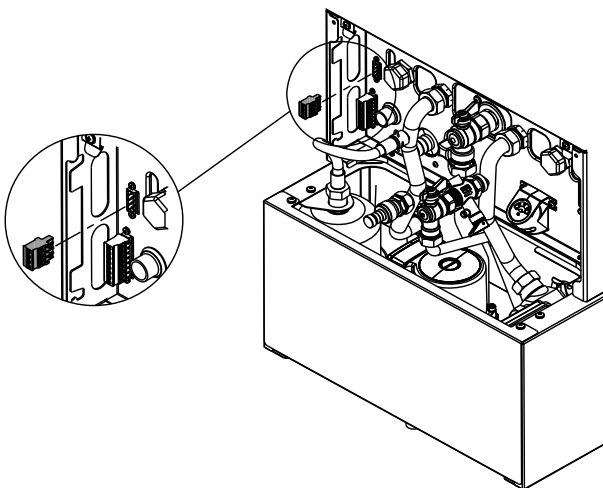

Cut the grommet with scissors

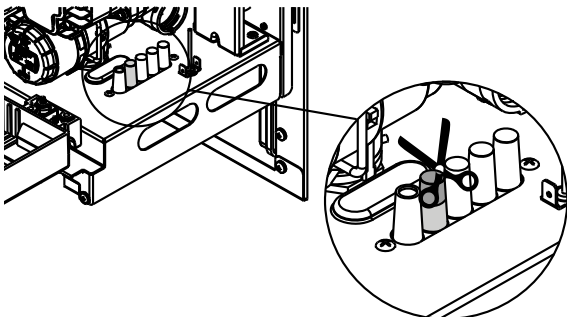

Wall-hung boilers

Wall-hung condensing boilers with DHW BI-TANK (dosseret)

CONNECT THE DOSSERET POWER CABLE IN THE BOILER

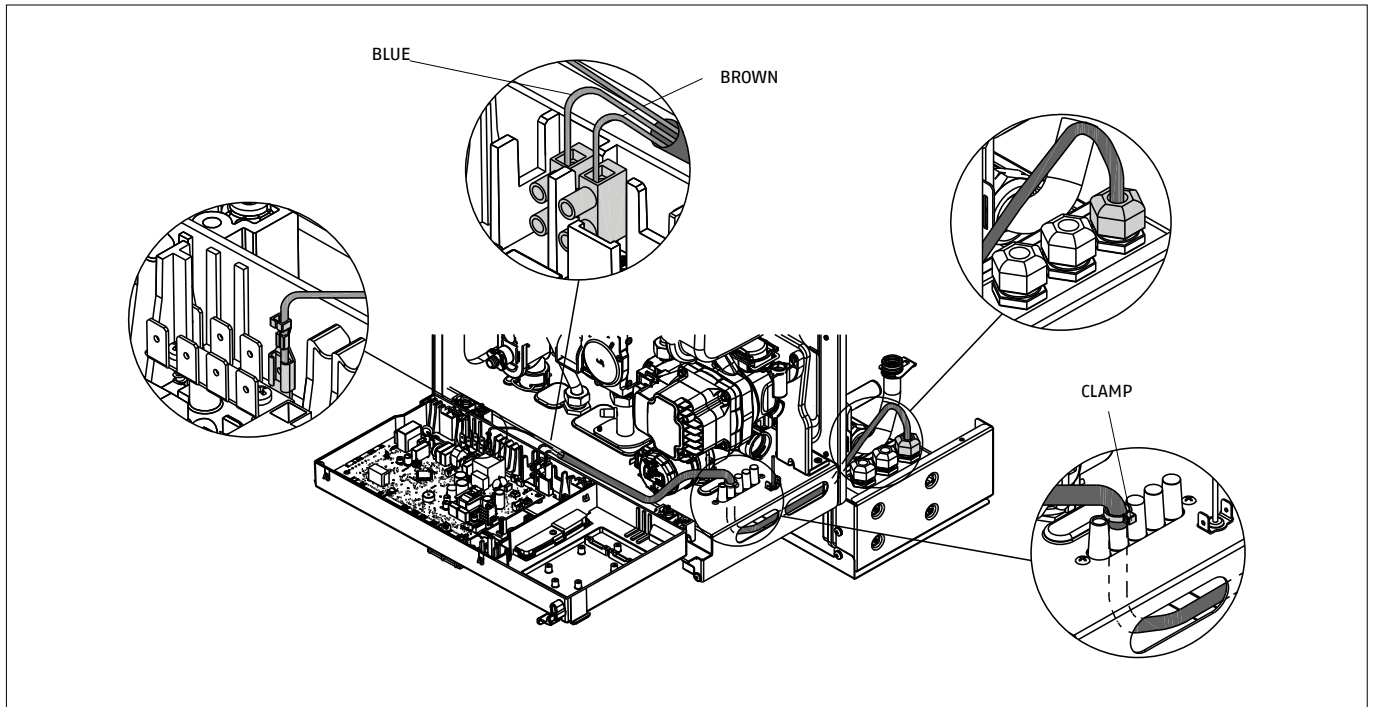

APPLY THE LOWER COVER

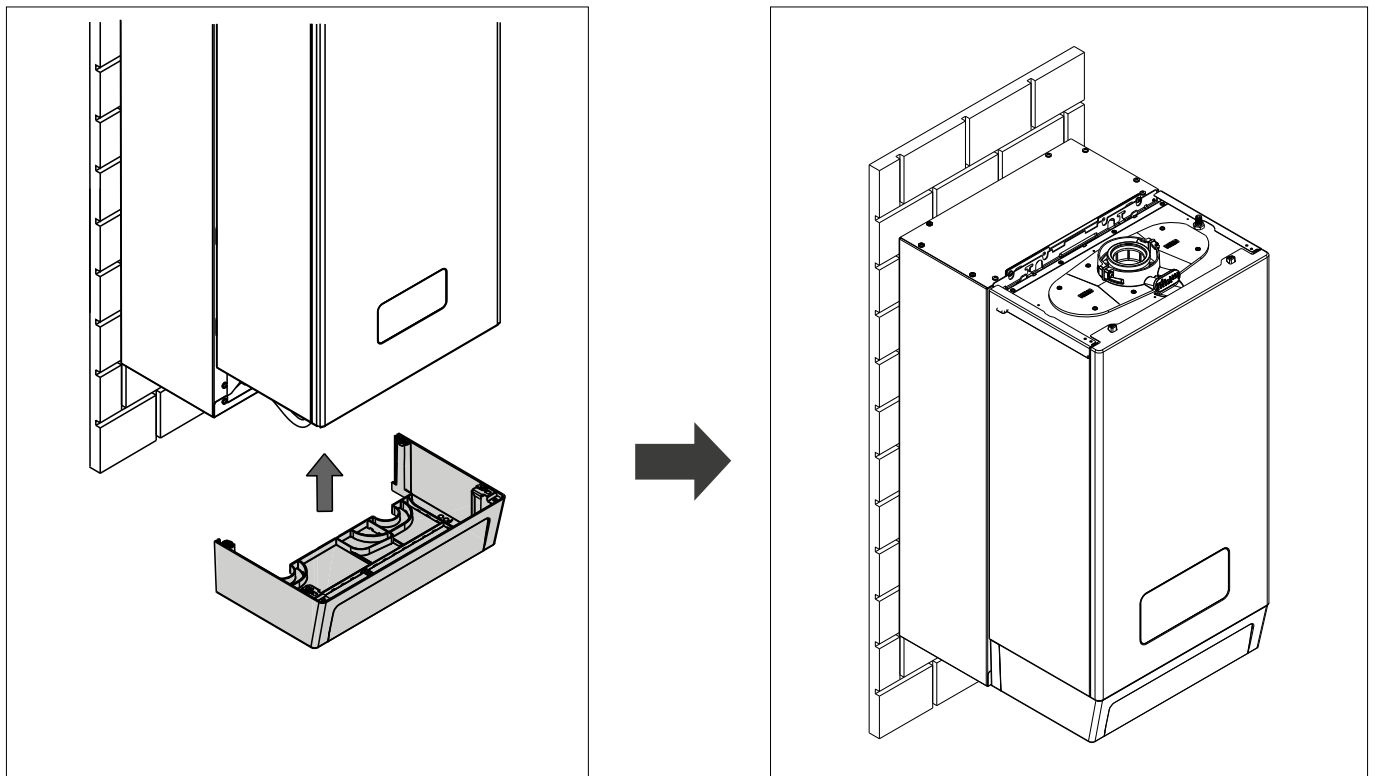

ACCESSORIES

SPECIFIC ACCESSORIES FOR COMMERCIAL COMPOSITIONS

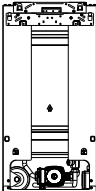
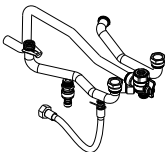
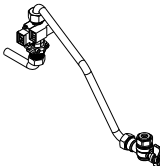
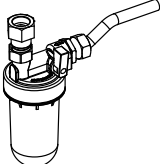
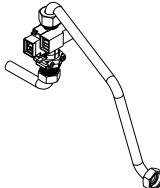
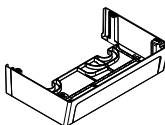
Ref.	Description
	DOSSERET DHW BI-TANK 25 kW
	HYDRAULIC CONNECTIONS OF DHW BI-TANK (DOSSERT) 30 kW
	FLOW SWITCH KIT WITH PIPES BOILER 25 kW (for combination WITH dosing device)
	COMPACT POLYPHOSPHATE DOSING DEVICE
	FLOW SWITCH KIT WITH PIPES BOILER 25 kW (for composition WITHOUT dosing device)
	COVER FOR CONNECTIONS

Wall-hung boilers

Wall-hung condensing boilers with DHW BI-TANK (dosseret)

HYDRAULIC ACCESSORIES

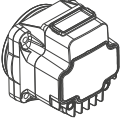
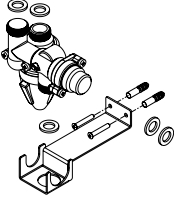
Ref.	Description
	ERP HIGH PREVALENCE CIRCULATOR (Accessory for boiler only)
	DIVERTING/MIXING VALVE KIT FOR COMBINED INSTANTANEOUS WALL-HUNG BOILERS



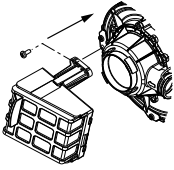

MECHANICAL ACCESSORIES

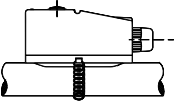
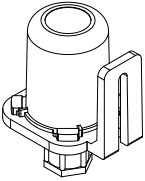
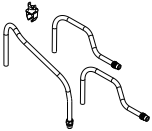
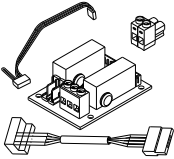
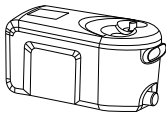
Ref.	Description
	AIR FILTER (Ideal for preventing impurities in the intake air from entering the heat exchanger and burner)

HYDRAULIC ACCESSORIES

Ref.	Description
	LIMIT THERMOSTAT FOR LOW TEMPERATURE SYSTEMS
	OUTDOOR TEMPERATURE PROBE KIT WITH CONNECTOR The outdoor probe kit allows you to detect the external temperature and activate the climate control program. It can be wall-hung and connected directly to the boiler control board. Essential for hybrid systems with boilers for managing the operating modes of energy sources.
	-15°C ANTIFREEZE RESISTANCE KIT The antifreeze resistance kit, recommended for outdoor installations, protects the domestic hot water circuit and the condensate trap from freezing within the limits stated in the instruction manual.
	BE09 BOARD WITH DOUBLE MULTIFUNCTION RELAY Ideal board for managing an additional circulator or zone valve and alarm remote control kit.
	CONDENSATE REFLUX PUMP KIT Piston pump with integrated tank (0.37 litres) specifically designed to evacuate acidic condensate. Kit consisting of 1 piston pump, 1 integrated detection block, 1 connection cable L=1,5m, 2 power supply wires, 2 safety alarm wires, wall mounting bracket.

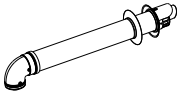
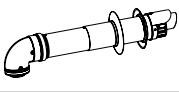
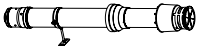
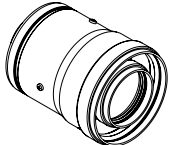
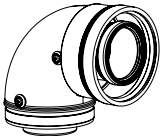
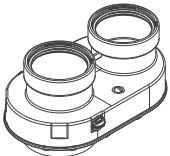



HYDRAULIC ACCESSORIES

Ref.	Description
	FIXED TWIN FLUE KIT FROM $\varnothing 80$ MM
	$\varnothing 80$ MM CLAPET KIT FOR PRESSURIZED COLLECTIVE CHIMNEYS
	$\varnothing 80/125$ MM CONCENTRIC CLAPET KIT FOR PRESSURIZED COLLECTIVE CHIMNEYS
	$\varnothing 60/100$ MM HORIZONTAL TERMINAL KIT
	$\varnothing 60/100$ MM TELESCOPIC TERMINAL KIT
	$\varnothing 60/100$ MM VERTICAL TERMINAL KIT
	$\varnothing 60-100$ MM VERTICAL CONNECTION ADAPTER KIT
	$\varnothing 60-100$ MM, 90° LOWERED CURVE KIT BOILER OUTLET
	ADJUSTABLE TWIN FLUE KIT FROM $\varnothing 60-100$ MM TO $\varnothing 80-80$ MM
	B23 FLUE ADAPTER FROM $\varnothing 60/100$ MM TO $\varnothing 80$ MM WITH AIR INTAKE
	COMPACT ADJUSTABLE TWIN FLUE KIT FROM $\varnothing 60-100$ MM TO $\varnothing 80-80$ MM

Wall-hung boilers

Wall-hung condensing boilers with DHW BI-TANK (dosseret)

Hi, Comfort controls for managing home comfort (*)

Ref.	Description
	<p>HI, COMFORT T100 WI-FI</p> <p>Complete kit for Wi-Fi installation, containing Hi, Comfort T100 and Hi, Comfort G100-W room controllers. The kit also includes batteries, connection cables, transformer, screws, wall plugs, double-sided adhesive tape, magnetic adhesive tape, and technical manual. ErP Contribution Class: VI-4% (*); I-1%.</p>
	<p>HI, COMFORT T100</p> <p>Hi, Comfort T100 room control for replacement or new installations, both for single zones or for expansion to multi-zone applications.</p> <p>Hi, Comfort T100 is compatible for Internet connection in combination with Hi, Comfort G100-W (optional). The package also includes batteries, screws, plugs, double-sided adhesive tape, and technical manual. ErP Contribution Class: V-3%(*); I-1%.</p>
	<p>HI, COMFORT G100-W</p> <p>Hi, Comfort G100-W is the device that allows connection to the Internet via your home Wi-Fi network. It also allows connection to the boiler's OTBus for advanced remote management. The package also includes: connection cables, transformer, magnetic adhesive.</p>
	<p>HI, COMFORT G100-R</p> <p>Radio frequency device that allows wireless connection of the Hi, Comfort control to the boiler (both ON-OFF and via OTBus). It can also be used in cases where the weak Wi-Fi signal does not allow the Hi, Comfort G100-W to be connected near the boiler.</p>

(*) With BUS connection.

DESCRIPTION PER SPECIFICATIONS

RESIDENCE HM AQUA is a type C condensing boiler designed for heating and domestic hot water production and, depending on the type of installation, can be divided into two categories:

- b23P-B53P type boiler, forced open installation, with flue gas exhaust and combustion air intake from the room in which it is installed. If the boiler is not installed outdoors, an air intake in the installation room is mandatory;
- type C(10)3 boiler; C13,C13x; C33,C33x; C43,C43x; C53,C53x; C63,C63x; C83,C83x; C93, C93x: sealed chamber appliance with flue gas evacuation duct and combustion air intake from the outside. No air intake required in the room where it is installed.

Wall-mounted condensing boilers with stainless steel primary heat exchanger and ACC (Active Combustion Control) system, which guarantees functionality, efficiency, and low emissions in all circumstances.

RESIDENCE HM AQUA can be installed indoors or outdoors in a partially protected location, i.e., in a place where the boiler is not exposed to direct action and infiltration of rain, snow, or hail. The boiler can operate in a temperature range from 0 to 60°C. NOx class 6 according to UNI EN 15502-1. Equipped with a multifunction control panel with backlit LCD display, touchscreen, and accompanying BUZZER, user functions, and descriptive scroll keys.

RESIDENCE HM AQUA also allows you to easily change the type of fuel gas simply by using the control panel; the self-adaptive combustion control automatically adjusts all combustion parameters without acting on the gas valve.

They are equipped with:

- New ACC (Active Combustion Control) combustion control system. This innovative control system, developed by Riello, guarantees functionality, efficiency, and low emissions in all circumstances. The ACC system uses an ionization sensor immersed in the burner flame which, through its information, allows the control board to act on the gas valve that regulates the fuel. This sophisticated control system allows for self-regulation of combustion, eliminating the need for initial calibration.
- Maximum heat output can be adjusted to the heating requirements of the system for boiler heating operation. Once the desired power (maximum heating) has been set, record the value and refer to the new value for subsequent checks.
- 1:10 High modulation;
- IOT Ready;
- Adaptable to operate with different gas compositions, different pipe lengths, and different altitudes (within the design limits) thanks to the ACC system.
- Self-diagnosis can be performed, which blocks the burner before emission thresholds exceed the limits allowed by regulations, thanks to the ACC system;
- High-efficiency modulating circulator already connected hydraulically and electrically, with a 6-meter head curve;
- Anti-blocking system that starts a operating cycle every 24 hours of downtime with the function selector in any position;
- Primary heat exchanger in stainless steel;
- Low-pollution premix burner, Class 6 NOx, according to UNI EN 15502-1, with non-return valve (clapet), fan, high modulation mixer, and gas diaphragm;
- Filling tap, venting tap;
- Siphon;
- Drain valve;
- Pressure transducer;
- Safety valve;
- Return probe, flue gas probe, and flow probe;
- Automatic antifreeze system, which activates when the temperature of the primary circuit water drops below 5°C. This system is always active and guarantees protection of the boiler up to an air temperature of 0°C at the installation site (protection up to -15°C with antifreeze resistors available as an accessory);
- Limit thermostat;
- Flame detection electrode/ionization sensor and ignition electrode;
- Ignition transformer;
- Pre-set with flue gas analysis cap;
- 9-liter expansion vessel;
- Hydraulic three-way valve (stepper);
- Hydrometer;
- Lower air vent valve;
- The control panel acts as a machine interface, displaying system settings and allowing access to parameters. The display normally shows the boiler flow temperature (in the case of a boiler with probe - optional) unless there is a heating request in progress, in which case the boiler flow temperature is displayed; after 10 seconds without any buttons being pressed, the interface displays the current time (backlight off);
- Programmable anti-legionella function.

Wall-hung boilers

Wall-hung condensing boilers with DHW BI-TANK (dosseret)

Included:

- Bypass valve
- Flat gasket
- SRD device
- Condensate drain pipe
- Flexible hose
- Safety valve
- 4-pole connector
- 8-pole connector

COMPLIANCE

The RESIDENCE HM AQUA boiler complies with:

- Directive 2009/142/EC on gas appliances until April 20, 2018, and Regulation (EU) 2016/426 from April 21, 2018
- Efficiency Directive: Article 7(2) and Annex III of 92/42/EEC
- Electromagnetic Compatibility Directive 2014/30/EU
- Low Voltage Directive 2014/35/EU
- Directive 2009/125/EC on the eco-design of energy-related products
- Regulation (EU) 2017/1369 Energy labelling
- Delegated Regulation (EU) No. 811/2013
- Delegated Regulation (EU) No. 813/2013
- UNI EN 15502-1

DESCRIPTION PER SPECIFICATIONS

The DHW Bi-TANK kit consists of:

- Boiler with 30-liter (15+15) stratified DHW bi-tank
- Circulator
- Check valve
- Valve body
- Electronic kit specifically developed for use with the Riello RESIDENCE HM AQUA boiler
- Flow switch
- Pre-wired electrical connections
- Metal template for fixing to the Riello RESIDENCE HM AQUA boiler

The dosseret kit is installed using specific hydraulic kits required for connection to the boiler (available as accessories).

RIELLO

RIELLO S.p.A.
37045 Legnago (VR) ITALY
tel. +39 0442 630111

www.riello.com



Riello reserves the right to change the information and specifications contained herein at any time and without notice. The contents and information contained herein are for informational purposes only and are not intended to provide legal or professional advice. Therefore, this document cannot be considered binding towards third parties.

©Riello S.p.A. All rights reserved