

# Solar thermal

## Solar systems

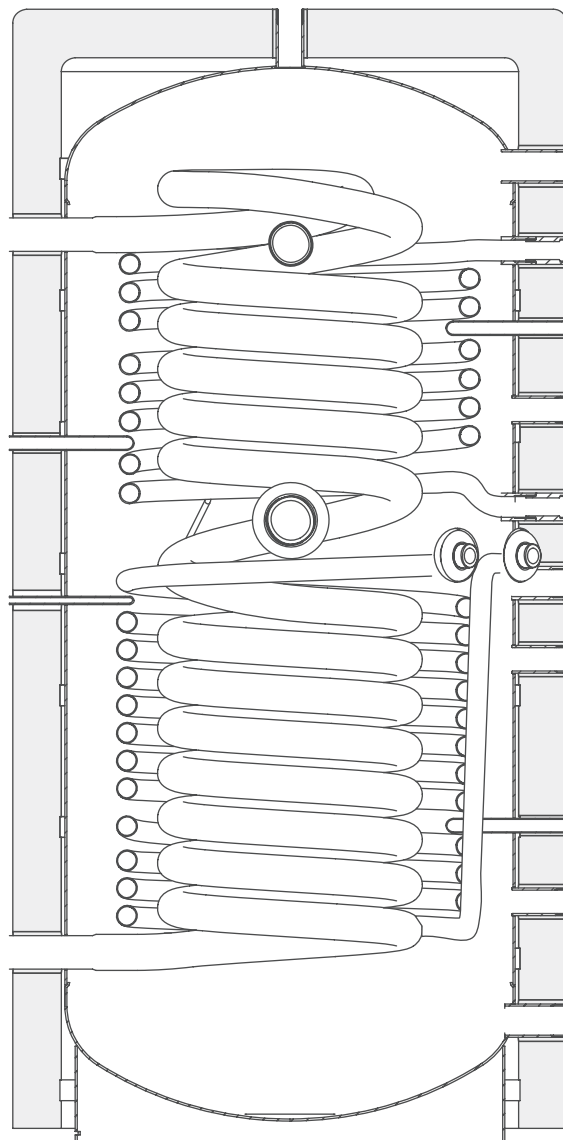



## Table of contents

Flat solar collector SCF-25/4B	4
Flat solar collector SCF-20B	22
Vertical flat solar collectors SCF-20/4B A e SCF-25/4B A	35
Natural circulation solar systems	
NB-SOL-A 160/2,5 - 200/2,5 - 200/4 - 300/4 - 300/5	47
Double-coil cylinders IDRA DS 200-300-430-550-750-1000	56
Double-coil cylinders IDRA DS FI 200 - 300 - 430 - 550	63
Double-coil cylinders IDRA N DS 1500 - 2000	73
Flanged solar cylinders IDRA PLUS DS 1000 - 1500 - 2000 - 3000	79
Single-coil cylinders IDRA C-HP MS	83
Single-coil cylinders IDRA HP 300-500	91
Hot/cold inertial storage tanks STOR H STOR H 60 - 120 - 200 - 300 - 400 - 500	97
Inertial storage units STOR M 300-500-1000-1500 and STOR 2000-3000	100
Module for the production of domestic hot water SC ACS 25	104
Module for the production of domestic hot water SC ACS 35	111
Module for the production of domestic hot water SC ACS 40	118
Module for the production of domestic hot water SC ACS 80	129
Module for the production of domestic hot water SC ACS 160	135
Module for solar circuit SC SUN 50	143
Module for solar circuit SC SUN 120 - 120 ACS	153
Accessories	164
Boilers and specific systems for solar systems	199
Examples of solar thermal systems	203

## Flat solar collector SCF-25/4B



**flat solar collector for forced circulation**  
**high efficiency ensured by the aluminium absorber with highly selective surface**  
**sealing between glass and frame with sealing material, without seal**  
**ultrasonic welded copper pipes**  
**stagnation temperature 200 °C**  
**total surface of 2.30 m<sup>2</sup>**  
**40 mm rock wool insulation**  
**vertical or horizontal installation possible**  
**possibility to connect up to 10 collectors in series vertically, up to 6 collectors horizontally**  
**wide range of accessories to facilitate installation**  
**reduced assembly time thanks to simple and reliable fastening systems**  
**solar collectors conforming to UNI-EN 12975 standards and Solar Keymark certification **  
**5-year warranty**

The flat solar collector SCF-25/4B has four connections and consists of an aluminium structure on which an aluminium absorbing plate is fixed, in one piece, with highly selective finish made through a vacuum treatment called "TiNOX", which allows very high performance for the collector.

The capturing plate is ultrasonic-welded on 12 copper tubes for the conduction of the heat transfer fluid.

In the vertical arrangement, the glycol flows from the bottom to the top, in parallel in the 12 copper tubes.

Each collector is protected by tempered solar glass with a low iron oxide content and a high energy transmission coefficient. The 4 cm thick glass wool insulation is placed at the bottom.

The temperature sensor is placed in a special copper pocket.

The mounting system is simple and, if installation is carried out correctly, it guarantees effective and long-lasting operation.

## Flat solar collector SCF-25/4B

## Technical data sheet

Description	Unit	SCF-25/4B
AG gross surface	m <sup>2</sup>	2.30
Aa opening surface	m <sup>2</sup>	2.15
Effective absorber surface	m <sup>2</sup>	2.14
Energy Q <sub>col</sub> (50°C) **	kWh/year	1055
Energy Q <sub>col</sub> (75°C) **	kWh/year	638
Specific productivity **	kWh/m <sup>2</sup> year	458.70
M-F connections	∅	1"
Empty weight	kg	44
Liquid content	litres	1.70
Recommended flow rate per m <sup>2</sup> of collector (*)	l/h	30
Type of glass - Thickness - Class		safety glass with anti-reflection surface - 3.2 mm - U1
Absorption (α)	%	95
Emissions (ε)	%	4
Maximum allowed pressure	bar	10
Stagnation temperature	°C	200
Maximum number of collectors that can be connected in series	no.	10 vertical / 6 horizontal

\* Capacity per m<sup>2</sup> min-max: 20-200 l/h.

\*\* Data from report for Würzburg.

## Influence of wind and snow on collectors

The maximum allowable wind and snow load (possibly combined) on the collector surface is 1500 Pa (corresponding to a wind speed of 175 km/h).

To determine the maximum wind speed consider:

- building height;
- solar system site;
- exposure and topography (area/buildings).

The maximum snow load depends on the region and the altitude of the area.

Wind speed, km/h	Inclination angle of solar collectors	Mass in kg, distributed over the different support points, to secure a collector from wind lifting
100	30°-45°	135
130	30°-45°	255
150	30°-45°	355

The indicated values are valid both for vertical and horizontal installation.

Connection pipe diameter with specific flow rate of 30 litres/m<sup>2</sup>h

Total surface area (m <sup>2</sup> )	2 - 4	6 - 12	14 - 20
Copper diameter (mm)	10 - 12	14	18
Steel diameter	3/8" - 1/2"	1/2"	3/4"

## Efficiency curves

Optical efficiency at absorber (η <sub>0</sub> )	Coefficients of heat loss of the absorber		IAM (50°)	Collector efficiency % (η <sub>col</sub> )
	a1 W/(m <sup>2</sup> K)	a2 W/(m <sup>2</sup> K <sup>2</sup> )		
0.802 <sup>(1)</sup>	4.28 <sup>(1)</sup>	0.0064 <sup>(1)</sup>	0.95 <sup>(1)</sup>	62.0 <sup>(2)</sup>

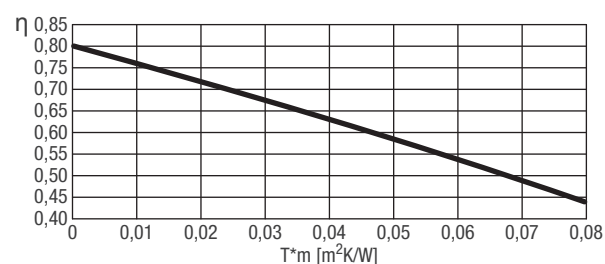

(1) Value referred to the opening area. Test according to ISO 9806 referred to 33.3% water-glycol mixture, flow rate of 160 litres/h and radiation of  $G = 800 \text{ W/m}^2$ .

$$T_m = (T_{IN \text{ collector}} + T_{OUT \text{ collector}}) / 2$$

$$T_m^* = (T_m - T_{\text{ambient}}) / G$$

(2) (\*\*) Calculated at a temperature difference of 40 K between the solar collector and the surrounding ambient air, with a total solar radiation, referred to the opening area, of  $1000 \text{ W/m}^2$ .

Flat solar collector SCF-25/4B

Overall dimensions and structural parts

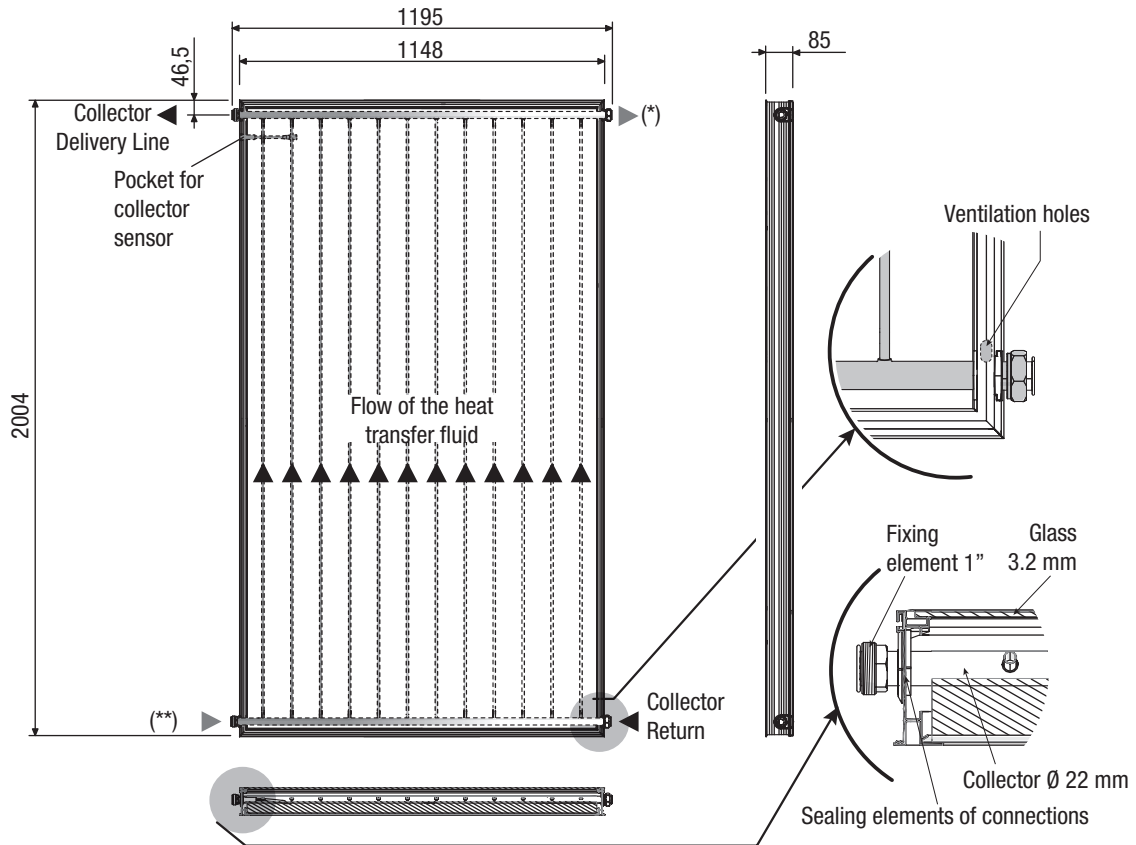

(\*) Collector alternative delivery line

(\*\*) Alternative collector return line

⚠ Delivery and return must be on opposite sides

## Flat solar collector SCF-25/4B

# Hydraulic connections

### Vertical configuration

Collectors are connected with each other so that the heat transfer fluid crosses them in parallel. Connection with the heat exchange circuit towards the exchanger must be made on the side of sensor socket (T) of the last collector of the series (see figure). The positioning of the socket on the collector allows the maximum transfer of heat accumulated in the collectors.

It is also possible to connect more than one line of solar collectors, both in series (provided that the number of solar collectors does not exceed 10 units per each series) and in parallel. In any case the circuit must be hydraulically balanced (see the following example diagrams).

### Horizontal configuration

Collectors are connected with each other so that the heat transfer fluid crosses them in series. Connection with the heat exchange circuit towards the exchanger must be made on the side of sensor socket (T) of the last collector of the series (see figure). It is also possible to connect more than one line of solar collectors, both in series (provided that the number of solar collectors does not exceed 6 units per each series) and in parallel. In any case the circuit must be hydraulically balanced (see the following example diagrams). Connection between collectors must be carried out only using the junction connector (including the proper insulation) supplied separately. This connector is used as expansion joint between collectors.

**Two lines in series  
Vertical configuration**

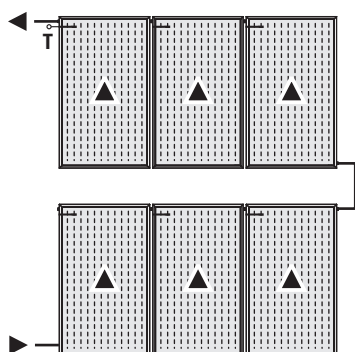

**Two lines in parallel  
Vertical configuration**

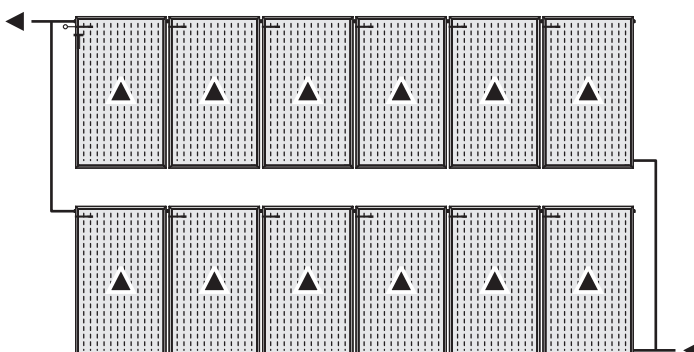

**Horizontal configuration**

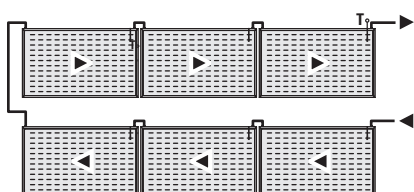

**Horizontal configuration**

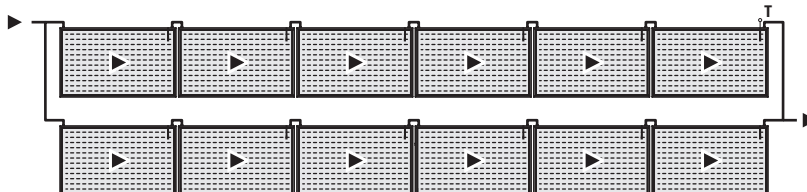

## Flat solar collector SCF-25/4B

### Bracket systems

Kit for parallel installation on pitched roof with stud bolt

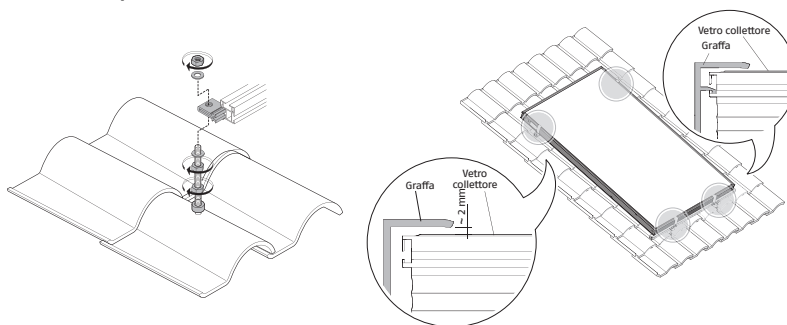

The compositions and measures of the kit are shown below.

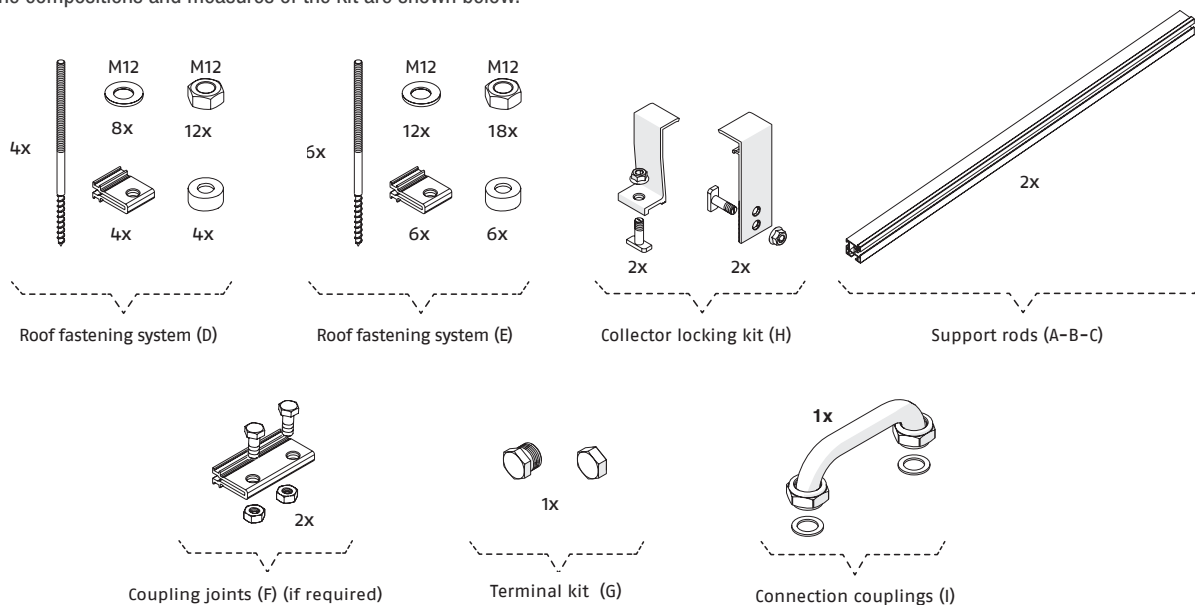

### Possible configurations for vertical installation

Components	Number of collectors						
	1	2	3	4	5	6	
Support rods	A	1x					
	B		1x				
	C			1x	2x	1x	2x
Fixing system	D	1x	1x		2x	1x	
	E			1x		1x	2x
Coupling joints	F				1x	1x	1x
Collector locking kit	H	1x	2x	3x	4x	5x	6x

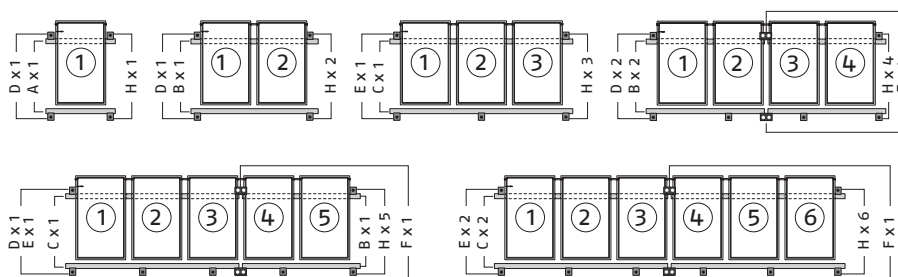

### Flat solar collector SCF-25/4B

## Possible configurations for horizontal installation

Components	Number of collectors						
	1	2	3	4	5	6	
Support rods	A	1x	1x	1x	1x	1x	
	B		1x	1x	2x	2x	3x
Fixing system	D	1x		1x		1x	
	E		1x	1x	2x	2x	3x
Coupling joints	F			1x	1x	2x	2x
Collector locking kit	H	1x	2x	3x	4x	5x	6x
Connection couplings	I		1x	2x	3x	4x	5x

All the elements to complete the system are available in the catalogue list for appropriate consultation.

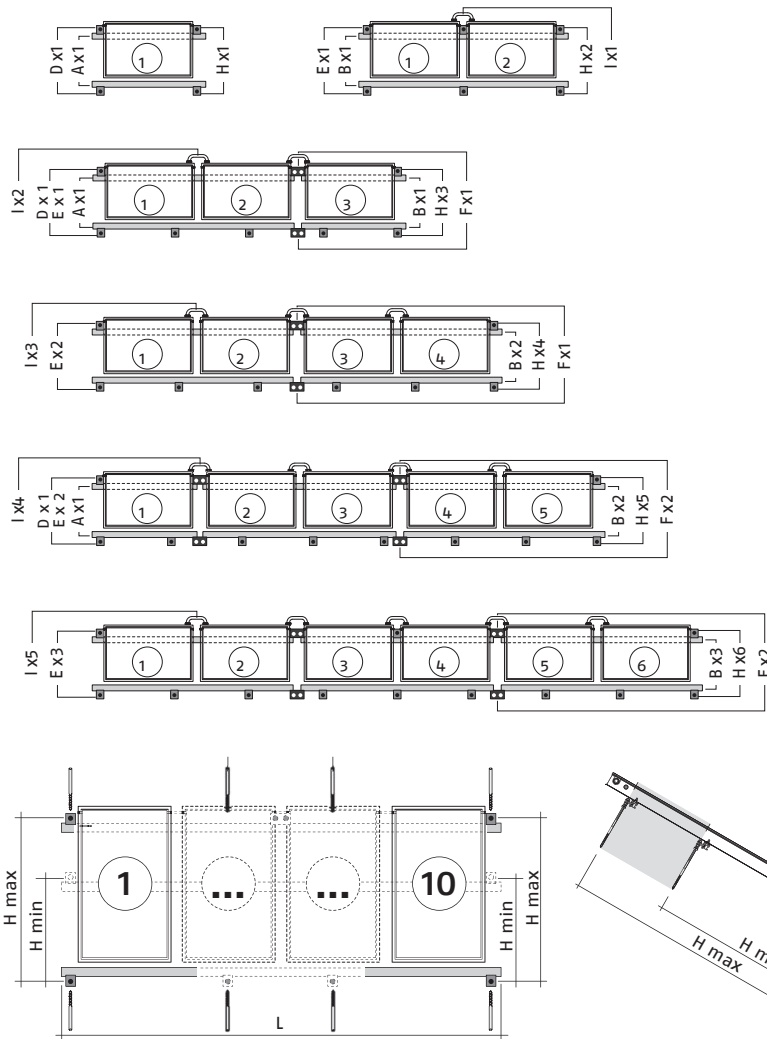

Dimension	H min - H max (in cm)	Number of collectors									
		1	2	3	4	5	6	7	8	9	10
2.5 m <sup>2</sup> VERTICAL collector	160 - 190	120	240	360	480	600	720	840*	960**	1080***	1440****
2.0 m <sup>2</sup> VERTICAL collector	145 - 170	110	220	330	440	550	660	-	-	-	-
2.5 m <sup>2</sup> HORIZONTAL collector	90 - 110	210	420	630	840	1050	1260	-	-	-	-

For vertical installations of systems with more than 6 collectors, the following solutions are recommended:

- \* for system from 7 collectors: a kit 5x collectors + a kit 2x collectors + a coupling joints;
- \*\* for system from 8 collectors: a kit 6x collectors + a kit 2x collectors + a coupling joints;
- \*\*\* for system from 9 collectors: a kit 6x collectors + a kit 3x collectors + a coupling joints;
- \*\*\*\* for system from 10 collectors: a kit 6x collectors + a kit 4x collectors + a coupling joints.

### Flat solar collector SCF-25/4B

Kit for 30° installation on flat roof with stud bolt

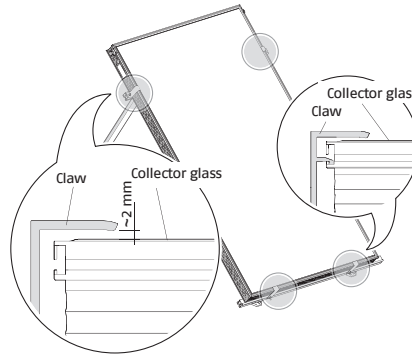
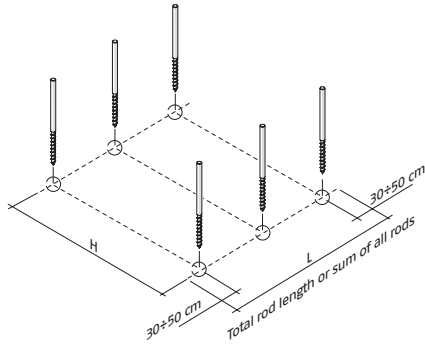

The compositions and measures of the kit are shown below.

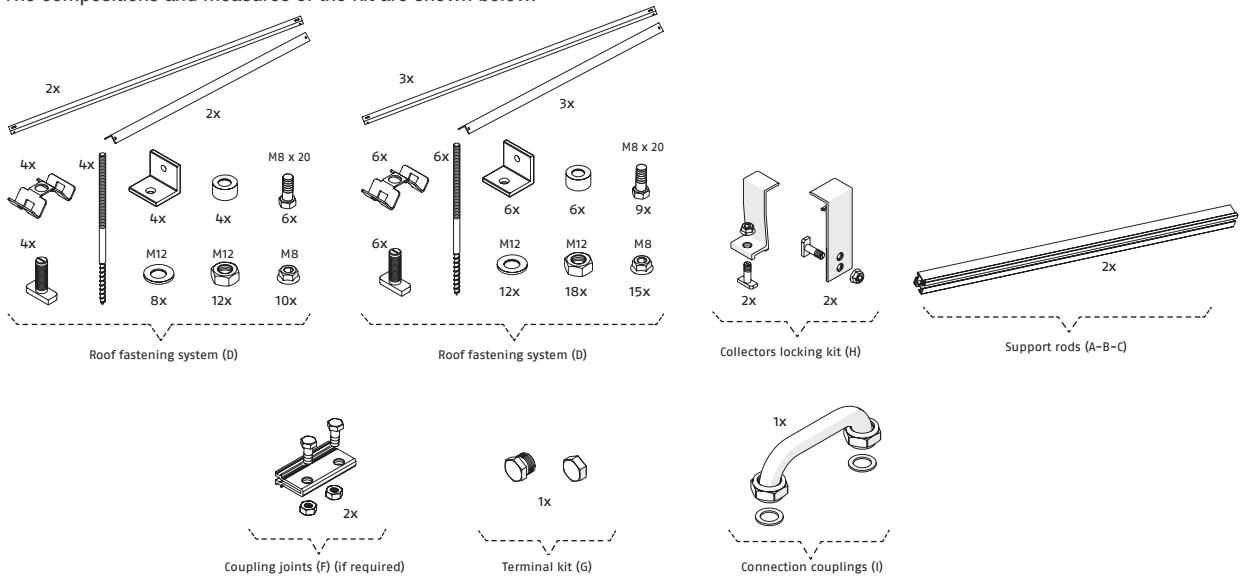

### Possible configurations for vertical installation

Components	Number of collectors						
	1	2	3	4	5	6	
Support rods	A	1x					
	B		1x		2x	1x	
	C			1x		1x	2x
Fixing system	D	1x	1x		2x	1x	
	E			1x		1x	2x
Coupling joints	F				1x	1x	1x
Collector locking kit	H	1x	2x	3x	4x	5x	6x

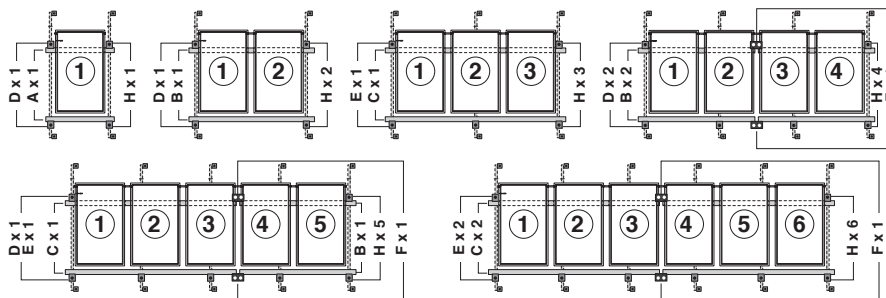

**Flat solar collector SCF-25/4B**

# Possible configurations for horizontal installation

Components	Number of collectors						
	1	2	3	4	5	6	
Support rods	A	1x					
	B		1x		2x	1x	
	C			1x		1x	2x
Fixing system	D	1x			2x	1x	
	E		1x	1x		1x	2x
Coupling joints	F				1x	1x	1x
Collector locking kit	H	1x	2x	3x	4x	5x	6x
Connection couplings	I		1x	2x	3x	4x	5x

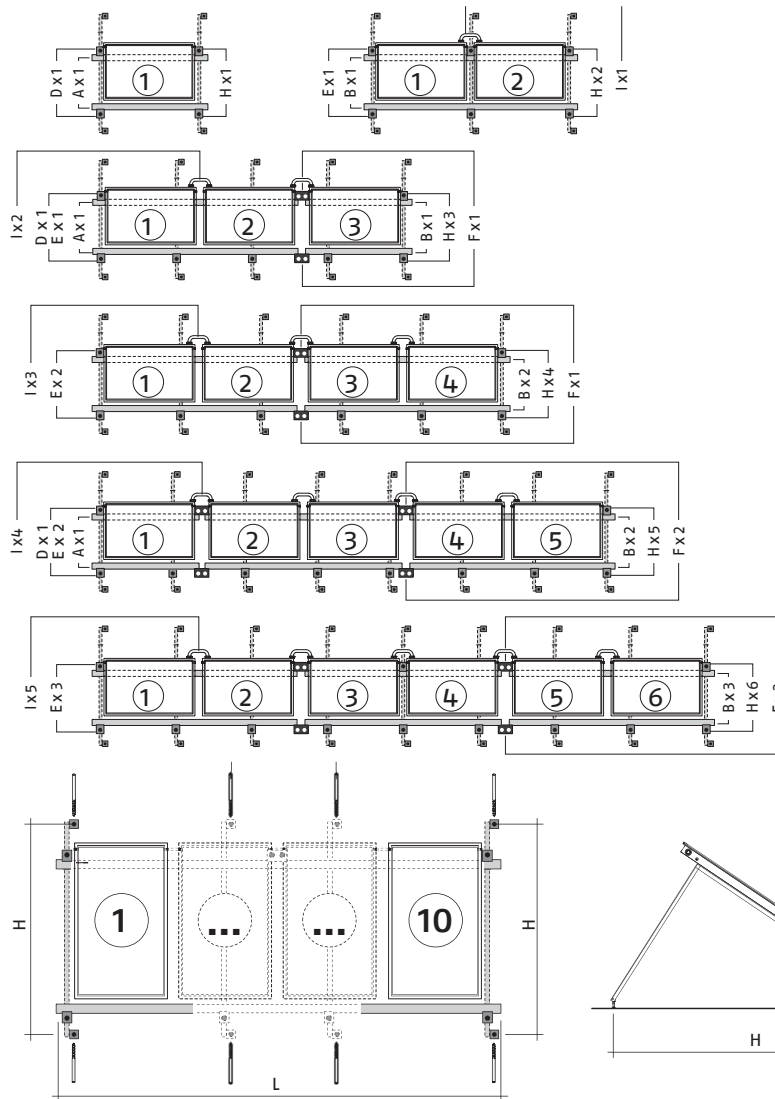

	Dimension H min - H max (in cm)	Number of collectors									
		1	2	3	4	5	6	7	8	9	10
		L - Length in cm									
2.5 m <sup>2</sup> VERTICAL collector	208	120	240	360	480	600	720	840*	960**	1080***	1440****
2.0 m <sup>2</sup> VERTICAL collector	208	110	220	330	440	550	660	-	-	-	-
2.5 m <sup>2</sup> HORIZONTAL collector	120	210	420	630	840	1050	1260	-	-	-	-

For vertical installations of systems with more than 6 collectors, the following solutions are recommended:

- \* for system from 7 collectors: a kit 5x collectors + a kit 2x collectors + a coupling joints;
- \*\* for system from 8 collectors: a kit 6x collectors + a kit 2x collectors + a coupling joints;
- \*\*\* for system from 9 collectors: a kit 6x collectors + a kit 3x collectors + a coupling joints;
- \*\*\*\* for system from 10 collectors: a kit 6x collectors + a kit 4x collectors + a coupling joints.

### Flat solar collector SCF-25/4B

#### Kit for 45° installation on flat roof with stud bolt

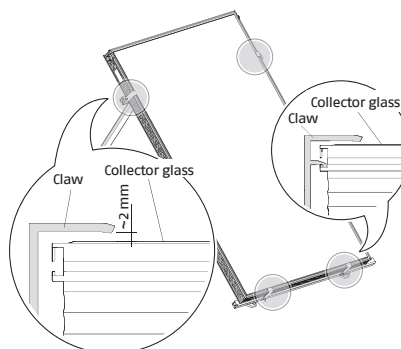
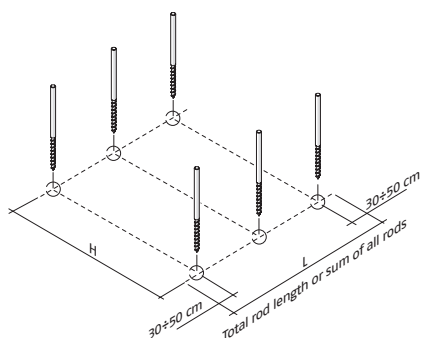

The compositions and measures of the kit are shown below.

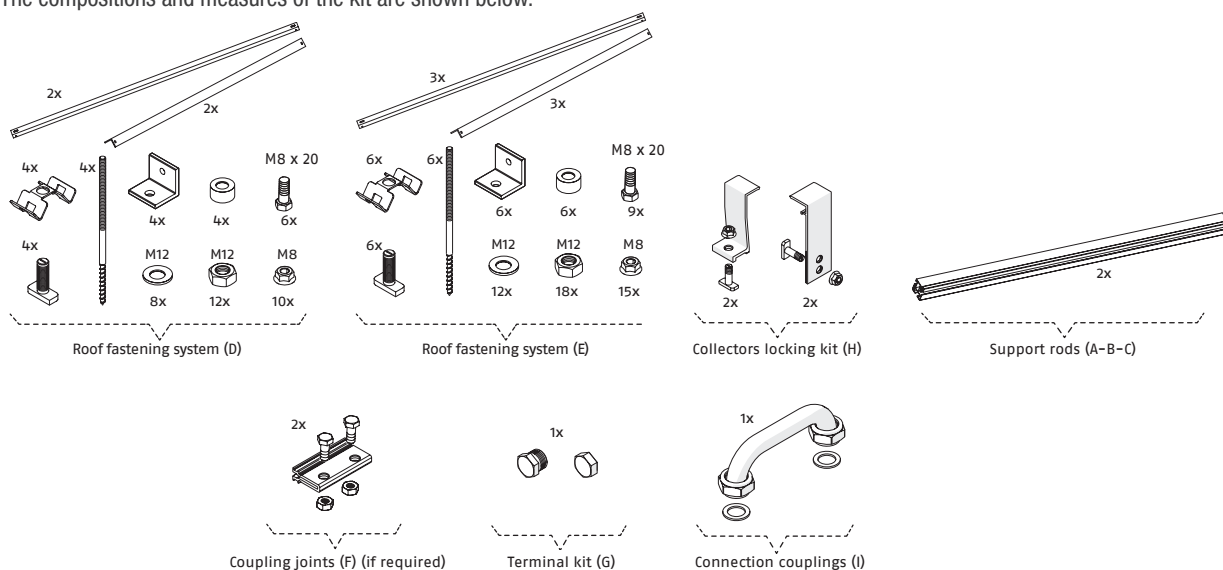

### Possible configurations for vertical installation

Components	Number of collectors					
	1	2	3	4	5	6
Support rods	A 1x	B 1x	C 1x	D 2x	E 1x	F 2x
Fixing system	D 1x	E 1x	F 1x	G 2x	H 1x	I 2x
Coupling joints	F 1x	G 1x	H 1x	I 1x	J 1x	K 1x
Collector locking kit	H 1x	I 2x	J 3x	K 4x	L 5x	M 6x

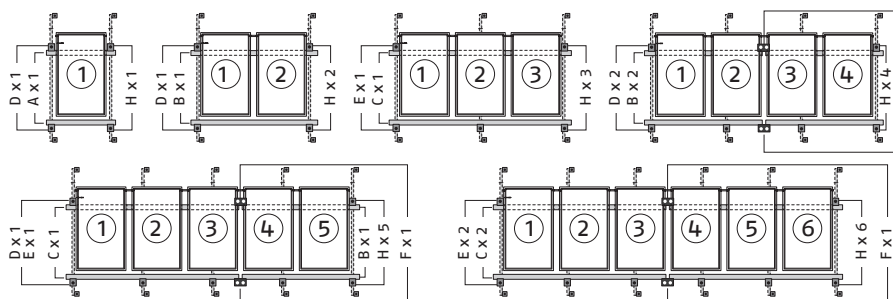

Flat solar collector SCF-25/4B

# Possible configurations for horizontal installation

Components	Number of collectors						
	1	2	3	4	5	6	
Support rods	A	1x		1x			
	B		1x	1x	2x	2x	3x
Fixing system	D	1x		1x		1x	
	E		1x	1x	2x	1x	
Coupling joints	F			1x	1x	2x	2x
Collector locking kit	H	1x	2x	3x	4x	5x	6x
Connection couplings	I		1x	2x	3x	4x	5x

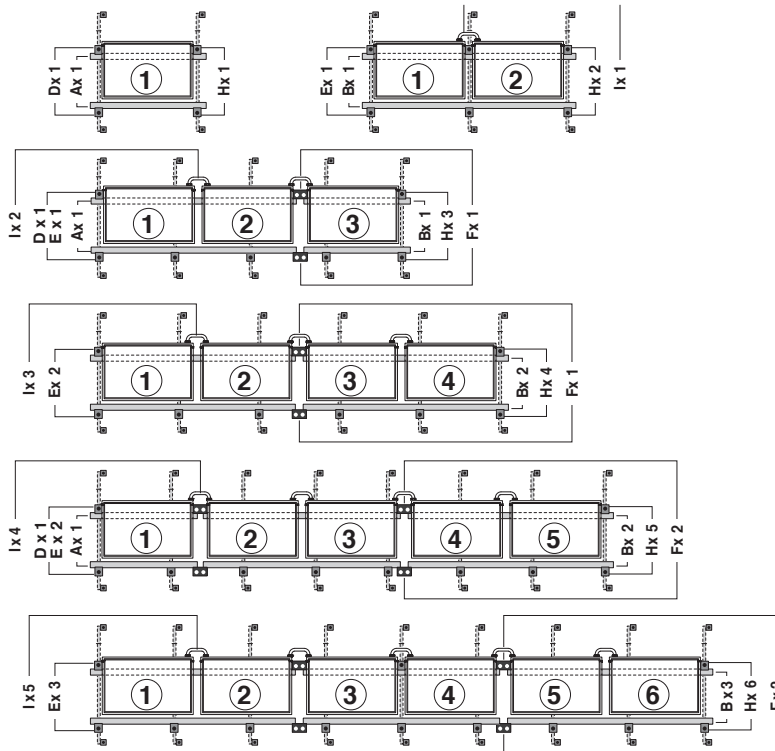

Evenly distribute the other fixing points along the entire length.

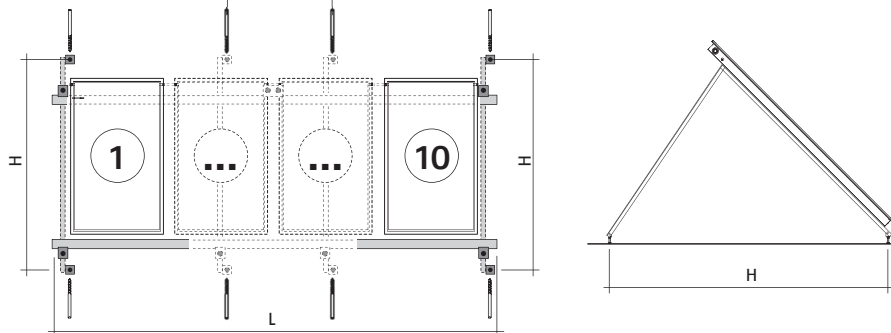

Dimension	H min - H max (in cm)	Number of collectors									
		1	2	3	4	5	6	7	8	9	10
2.5 m <sup>2</sup> VERTICAL collector	201	120	240	360	480	600	720	840*	960**	1080***	1440****
2.0 m <sup>2</sup> VERTICAL collector	201	110	220	330	440	550	660	-	-	-	-
2.5 m <sup>2</sup> HORIZONTAL collector	128	210	420	630	840	1050	1260	-	-	-	-

For vertical installations of systems with more than 6 collectors, the following solutions are recommended:

- \* for system from 7 collectors: a kit 5x collectors + a kit 2x collectors + a coupling joints;
- \*\* for system from 8 collectors: a kit 6x collectors + a kit 2x collectors + a coupling joints;
- \*\*\* for system from 9 collectors: a kit 6x collectors + a kit 3x collectors + a coupling joints;
- \*\*\*\* for system from 10 collectors: a kit 6x collectors + a kit 4x collectors + a coupling joints.

## Flat solar collector SCF-25/4B

### Kit for parallel installation on pitched roof with undertile brackets

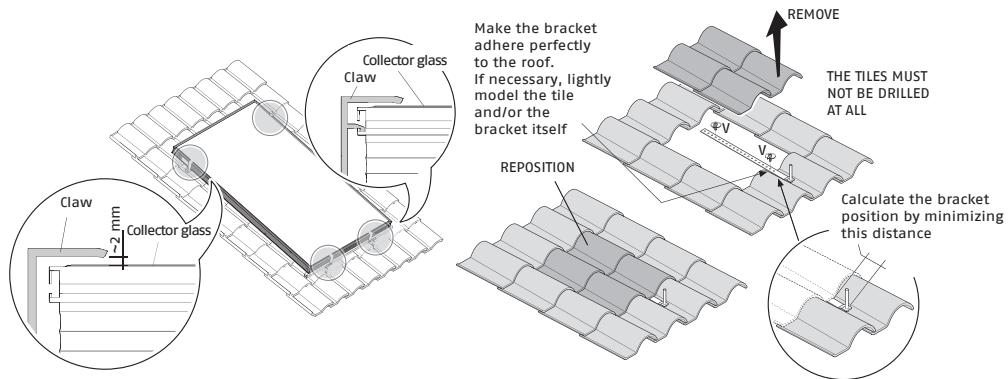

The compositions and measures of the kit are shown below.

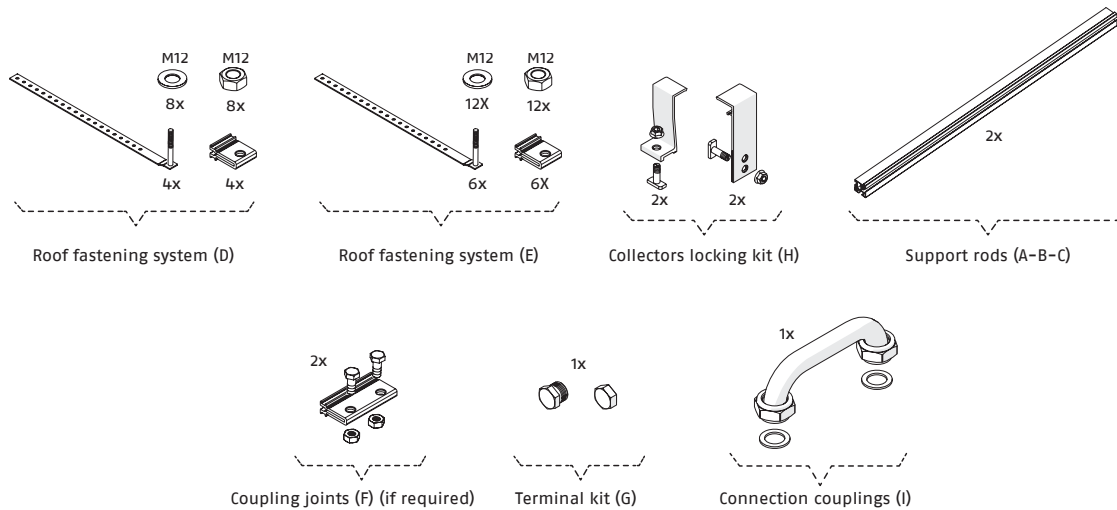

## Possible configurations for vertical installation

Components	Number of collectors						
	1	2	3	4	5	6	
Support rods	A	1x					
	B		1x		2x	1x	
	C			1x		1x	2x
Fixing system	D	1x	1x		2x	1x	
	E			1x		1x	2x
Coupling joints	F				1x	1x	1x
Collector locking kit	H	1x	2x	3x	4x	5x	6x

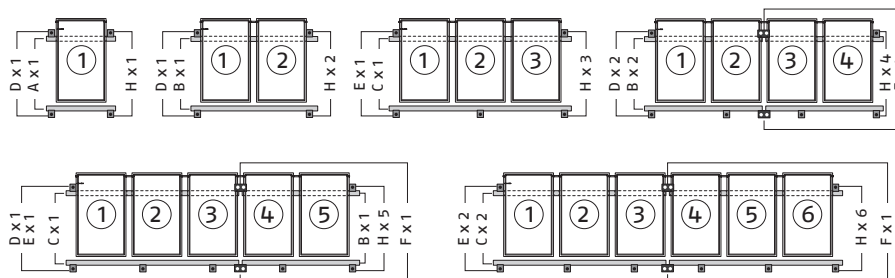

**Flat solar collector SCF-25/4B**

# Possible configurations for horizontal installation

Components	Number of collectors						
	1	2	3	4	5	6	
Support rods	A	1x	1x	1x	1x	1x	
	B		1x	1x	2x	2x	3x
Fixing system	D	1x		1x		1x	
	E		1x	1x	2x	2x	3x
Coupling joints	F			1x	1x	2x	2x
Collector locking kit	H	1x	2x	3x	4x	5x	6x
Connection couplings	I		1x	2x	3x	4x	5x

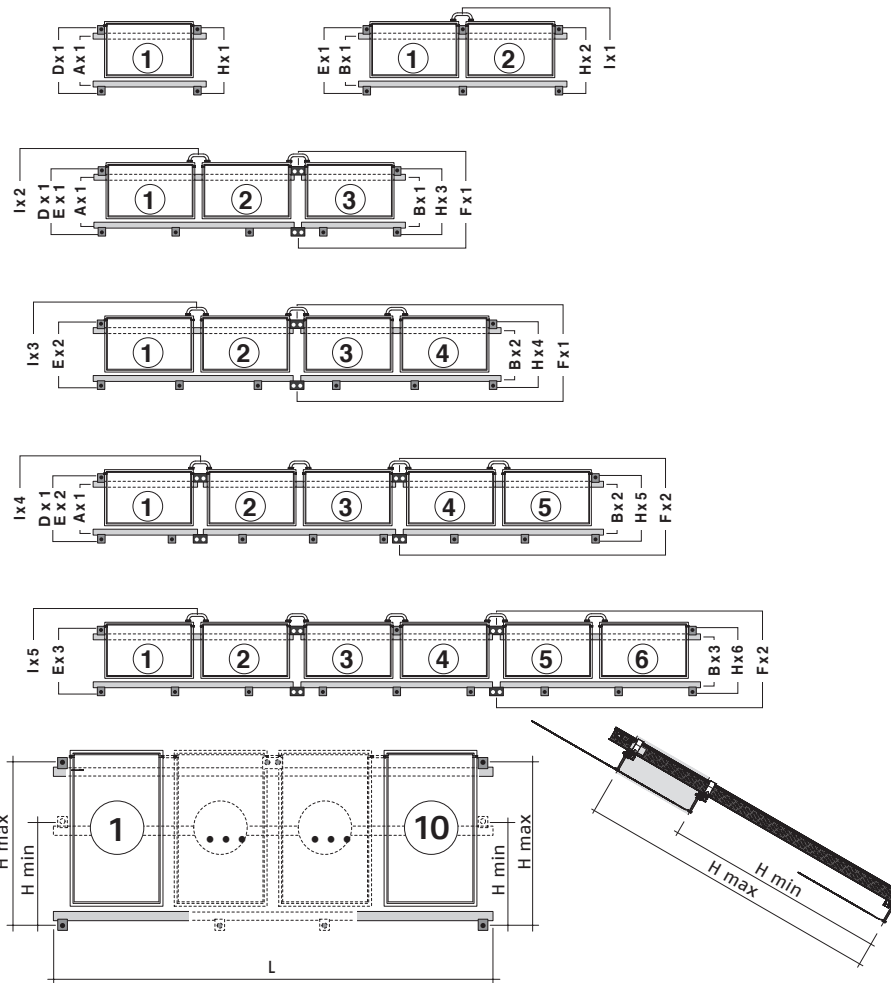

Dimension	Number of collectors										
	1	2	3	4	5	6	7	8	9	10	
H min - H max (in cm)	L - Length in cm										
2.5 m <sup>2</sup> VERTICAL collector	201	120	240	360	480	600	720	840*	960**	1080***	1440****
2.0 m <sup>2</sup> VERTICAL collector	201	110	220	330	440	550	660	-	-	-	-
2.5 m <sup>2</sup> HORIZONTAL collector	128	210	420	630	840	1050	1260	-	-	-	-

For vertical installations of systems with more than 6 collectors, the following solutions are recommended:

- \* for system from 7 collectors: a kit 5x collectors + a kit 2x collectors + a coupling joints;
- \*\* for system from 8 collectors: a kit 6x collectors + a kit 2x collectors + a coupling joints;
- \*\*\* for system from 9 collectors: a kit 6x collectors + a kit 3x collectors + a coupling joints;
- \*\*\*\* for system from 10 collectors: a kit 6x collectors + a kit 4x collectors + a coupling joints.

### Flat solar collector SCF-25/4B

#### Kit for parallel installation on pitched roof with adjustable undertile brackets

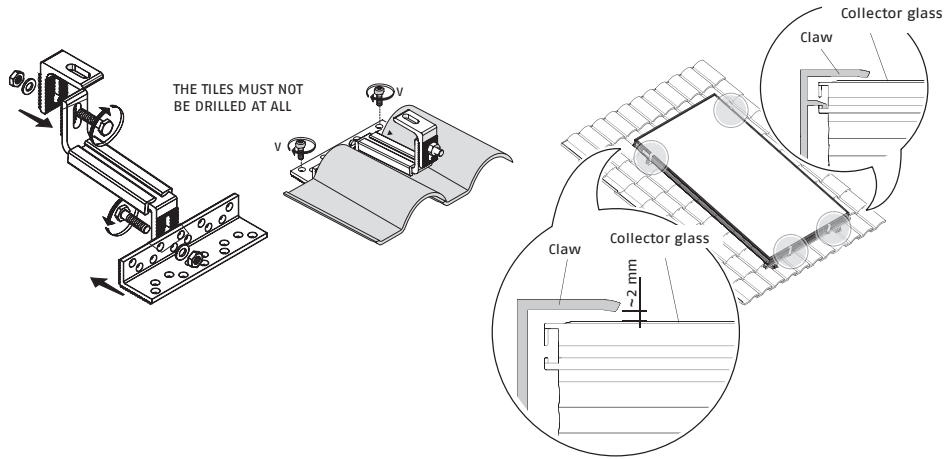

The compositions and measures of the kit are shown below.

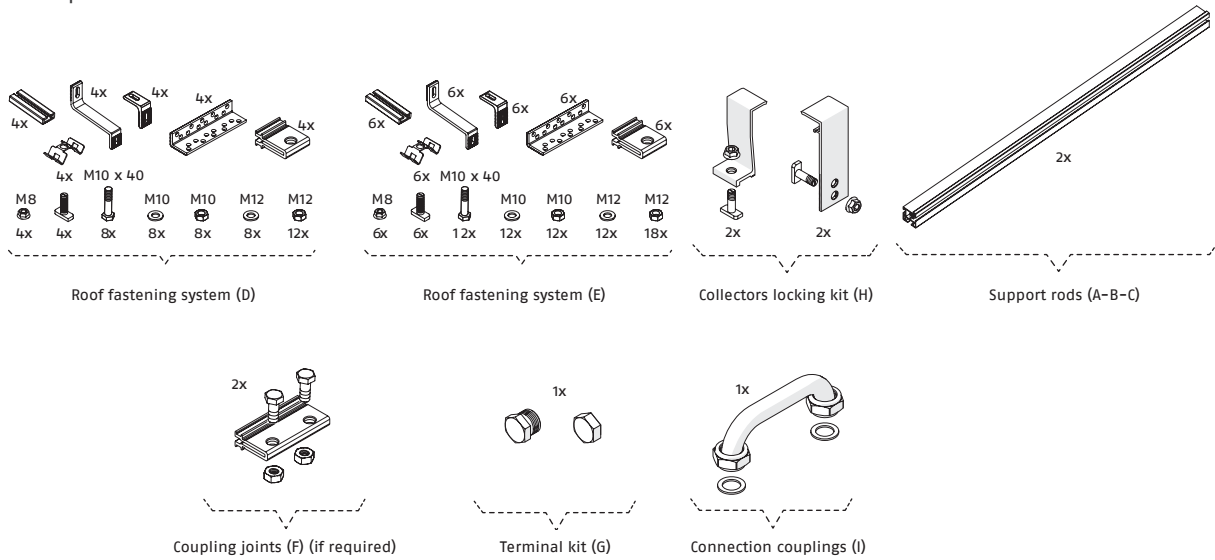

### Possible configurations for vertical installation

Components	Number of collectors					
	1	2	3	4	5	6
Support rods	A 1x	B 1x	C 1x	D 2x	E 1x	F 2x
Fixing system	D 1x	E 1x	F 1x	G 2x	H 1x	I 2x
Coupling joints	F 1x	G 1x	H 1x	I 1x	J 1x	K 1x
Collector locking kit	H 1x	I 2x	J 3x	K 4x	L 5x	M 6x

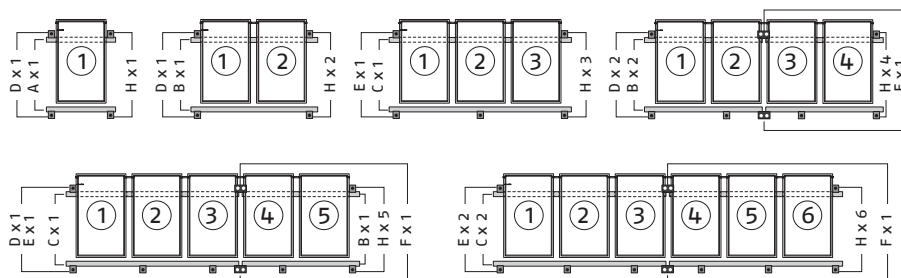

### Flat solar collector SCF-25/4B

## Possible configurations for horizontal installation

Components	Number of collectors						
	1	2	3	4	5	6	
Support rods	A	1x	1x	1x	1x	1x	
	B		1x	1x	2x	2x	3x
Fixing system	D	1x		1x		1x	
	E		1x	1x	2x	2x	3x
Coupling joints	F			1x	1x	2x	2x
Collector locking kit	H	1x	2x	3x	4x	5x	6x
Connection couplings	I		1x	2x	3x	4x	5x

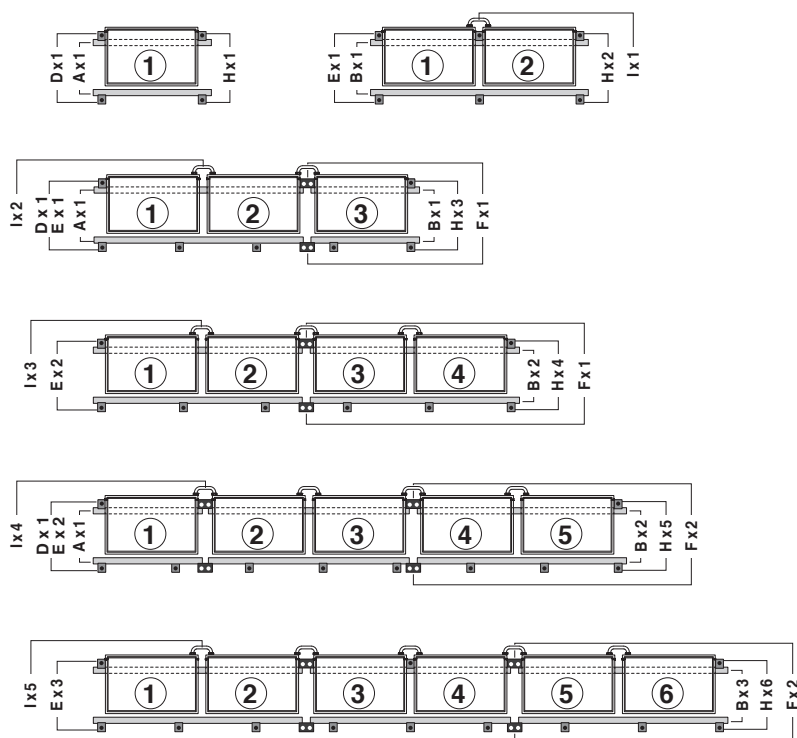

Evenly distribute the other fixing points along the entire length.

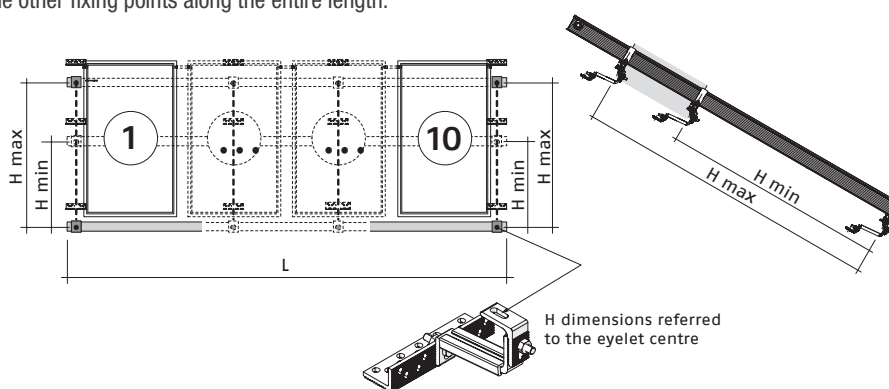

Dimension H min - H max (in cm)	Number of collectors										
	1	2	3	4	5	6	7	8	9	10	
	L - Length in cm										
Collettore 2,5 m <sup>2</sup> VERTICALE	201	120	240	360	480	600	720	840*	960**	1080***	1440****
Collettore 2,0 m <sup>2</sup> VERTICALE	201	110	220	330	440	550	660	-	-	-	-
Collettore 2,5 m <sup>2</sup> ORIZZONTALE	128	210	420	630	840	1050	1260	-	-	-	-

For vertical installations of systems with more than 6 collectors, the following solutions are recommended:

- \* for system from 7 collectors: a kit 5x collectors + a kit 2x collectors + a coupling joints;
- \*\* for system from 8 collectors: a kit 6x collectors + a kit 2x collectors + a coupling joints;
- \*\*\* for system from 9 collectors: a kit 6x collectors + a kit 3x collectors + a coupling joints;
- \*\*\*\* for system from 10 collectors: a kit 6x collectors + a kit 4x collectors + a coupling joints.

**Flat solar collector SCF-25/4B**

# Source water system

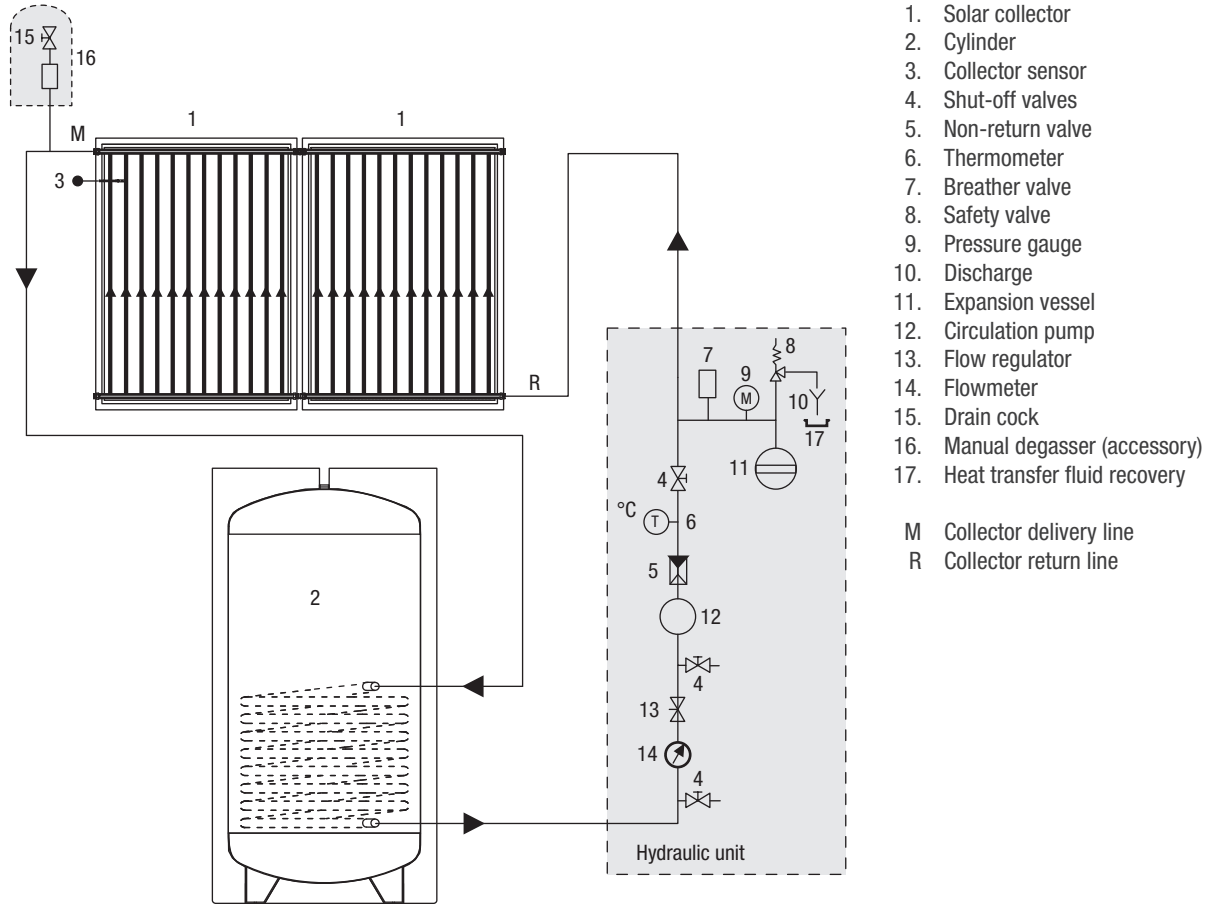

## Solar collector pressure drop

33.3% / 66.7% anti-freeze/water mixture and heat transfer fluid temperature = 20 °C.

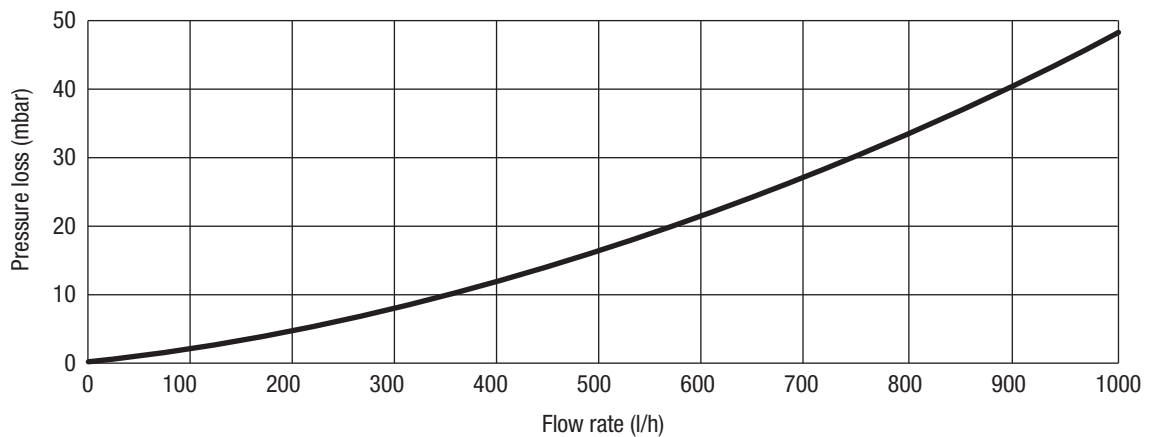

## Flat solar collector SCF-25/4B

### Positioning the sensors

The temperature sensor must be mounted in the pocket closest to the collector delivery pipe. Ensure optimal contact between sensor and pocket. Only materials with adequate temperature resistance

(up to 250°C for sensor element, cables, sealing materials, insulation) can be used for sensor installation.

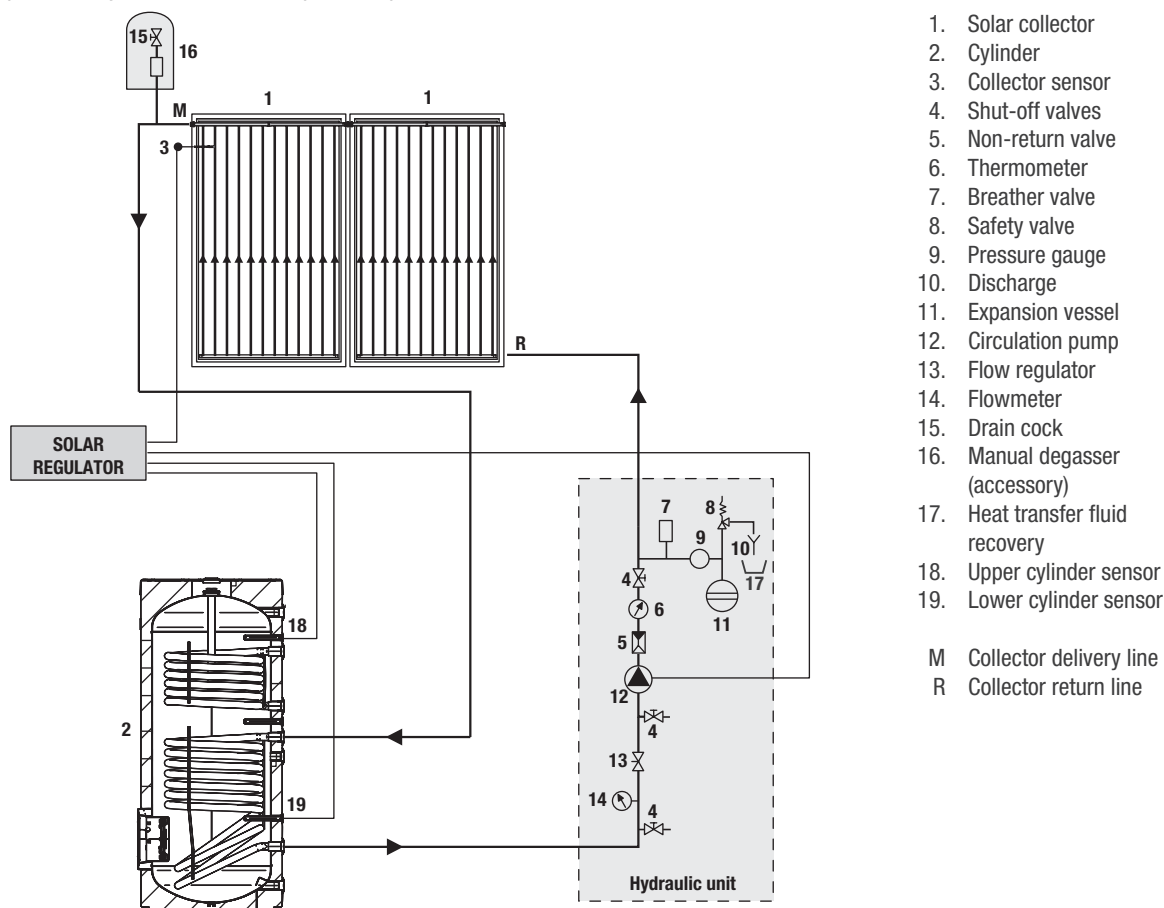

1. Solar collector
2. Cylinder
3. Collector sensor
4. Shut-off valves
5. Non-return valve
6. Thermometer
7. Breather valve
8. Safety valve
9. Pressure gauge
10. Discharge
11. Expansion vessel
12. Circulation pump
13. Flow regulator
14. Flowmeter
15. Drain cock
16. Manual degasser (accessory)
17. Heat transfer fluid recovery
18. Upper cylinder sensor
19. Lower cylinder sensor

M Collector delivery line  
R Collector return line

## Installation

### Instructions for installation

Installation may only be carried out by qualified personnel. Only the material included in the scope of supply may be used. The frame and its connections to the masonry parts must be checked by a structural engineer according to the circumstances on site.

### Static features

Only install on sufficiently strong roof surfaces or frames. The strength of the roof or frame must be checked on site by a structural engineer before installing the collectors. In this process, the suitability of the frame for the sealing of screw connections for the fastening of the collectors must be checked. The entire frame must be checked by a structural engineer in accordance with the regulations in force, especially in areas with heavy snowfall or in areas exposed to strong winds. All the characteristics of the installation site (gusts of wind, formation of vortices, etc.), which can lead to increased loads on the structures, must therefore be taken into account.

### Lightning protection

Solar circuit metal ducts must be connected through a (yellow-green) conductor of at least 16 mm<sup>2</sup> Cu (H07 V-U or R) to the potential compensation main bar. If a lightning rod is already installed, collectors can be integrated in the existing system. If this is not the case, it is possible to carry out earthing with a buried earth cable. The earth duct must be laid outside the house. Furthermore, the earth cable must be connected to the compensation bar through a duct having the same diameter.

### Connections

Collectors must be connected in series through connectors and seals. If hoses as connection elements are not provided, it is necessary to provide connection ducts with suitable devices for compensation of deformations caused by temperature inversions (expansion joints, hoses). When tightening the fitting with pliers or wrench it is necessary to hold the other fitting with a second wrench in order not to damage the absorber.

## Flat solar collector SCF-25/4B

All the pipes in the hydraulic circuit must be insulated in accordance with the regulations in force. Insulators must be protected against weather and attacks by animals.

## Collector inclination / Overview

The collector is suitable for an inclination of minimum 15°, up to a maximum of 75°. All connections of the collectors as well as the ventilation and vent holes must be protected from impurities such as dust deposits, etc. In systems with mainly summer load (production of domestic hot water), aim the collector from east to west and with an inclination varying from 20 to 60°. The ideal direction is southwards, with inclination equal to the latitude of the location -10°. In system with mainly winter load (systems that integrate domestic hot water production and space heating), aim the solar collector towards the south (south-east, south-west) with an inclination greater than 35°. The ideal direction is southwards, with inclination equal to the latitude of the location +10°.

## Flushing and filling

For safety reasons, filling should only be carried out when there is no sunlight. In areas subject to frost, it is necessary to use a 40% glycol solution for flat collectors.

The antifreeze must be mixed with water before filling.

If the system is flushed before filling the antifreeze, pay attention to any water deposits in the collector that may freeze.

## Vent

Venting must be carried out:

- At the time of commissioning (after filling).
- If necessary, e.g. in the event of a fault.

Carefully make sure that the system is completely vented.

Risk of burns with liquid in the collectors.

Only operate the vent valve if the temperature of the heat transfer fluid is below 60 °C.

## Check of the heat transfer fluid

The heat transfer fluid must be checked every 2 years to verify its antifreeze characteristics and its pH value.

Check the antifreeze with a suitable tool, refractometer or densimeter (nominal value approx. -30 °C): if the limit value of -26 °C is exceeded, change or add antifreeze

Check the pH value with litmus paper (nominal value approx. 7.5): if the measured value is below the limit value of 7, we recommend replacing the mixture.

## Water+glycol pre-mixing

The glycol is supplied separately in standard packages and must be mixed with water in a container before filling the system (for example 40% glycol and 60% water allow a resistance to frost up to -21 °C).

- The propylene glycol supplied is specifically designed for solar applications as it retains its characteristics in the range of -32 ÷ 180 °C. It is also non-toxic, biodegradable and biocompatible.
- Do not fill pure glycol into the system and then add water.
- Do not use manual or automatic filling systems.
- If the chlorine content is very high, distilled water must be used for the mixture.

Antifreeze	Temperature	Density
50%	-32 °C	1.045 kg/dm <sup>3</sup>
40%	-21 °C	1.037 kg/dm <sup>3</sup>
30%	-13 °C	1.029 kg/dm <sup>3</sup>

## System filling

1. Open the non-return valve (A).
2. Open the air vent at the highest point (see figure) and keep it open throughout the filling operation.
3. Open the breather valve (7).
4. Circulate the heat transfer fluid with an external pump until all air bubbles are eliminated. Close the manual degasser valve.
5. Briefly increase the system pressure to 4 bar.
6. Start up the system for about 20 minutes.
7. Repeat the air bleeding operation from point 2 until the system is completely de-aerated.
8. Set the system pressure to 3 bar.
9. Close the non-return valve (A) and the air vents previously opened to prevent any evaporation of the heat transfer fluid.

Do not fill the system with strong sunlight and collectors at high temperature.

Make sure that the air bubbles are completely eliminated by also using the vent on the hydraulic unit.

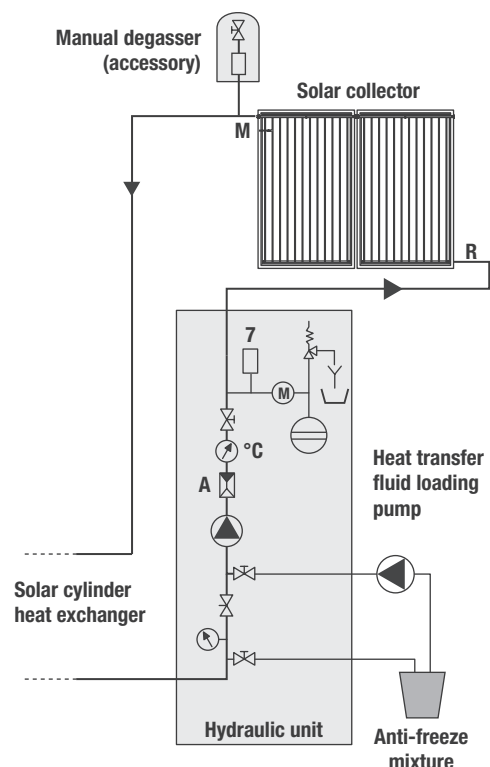

**Flat solar collector SCF-25/4B**

# Table for choosing the solar composition

Coverage of DHW needs							
FORCED CIRCULATION SOLUTION							
USE	APPLICATION	NO. OF PERSONS	NO. OF SOLAR COLLECTORS	STORAGE CAPACITY litres	SYSTEM	LAYOUT	BOILER TYPE
domestic hot water	independent heating	2-3	1 SCF-25/4B	200	SCF-25/4B 200/1	1-2	instantaneous/heating only
		4-5	2 SCF-25/4B	300	SCF-25/4B 300/2	1-2	instantaneous/heating only
		5-6	3 SCF-25/4B	430	SCF-25/4B 400/3	1-2	heating only

The content of the following table is purely indicative and is not a substitute for planning by a qualified technician.

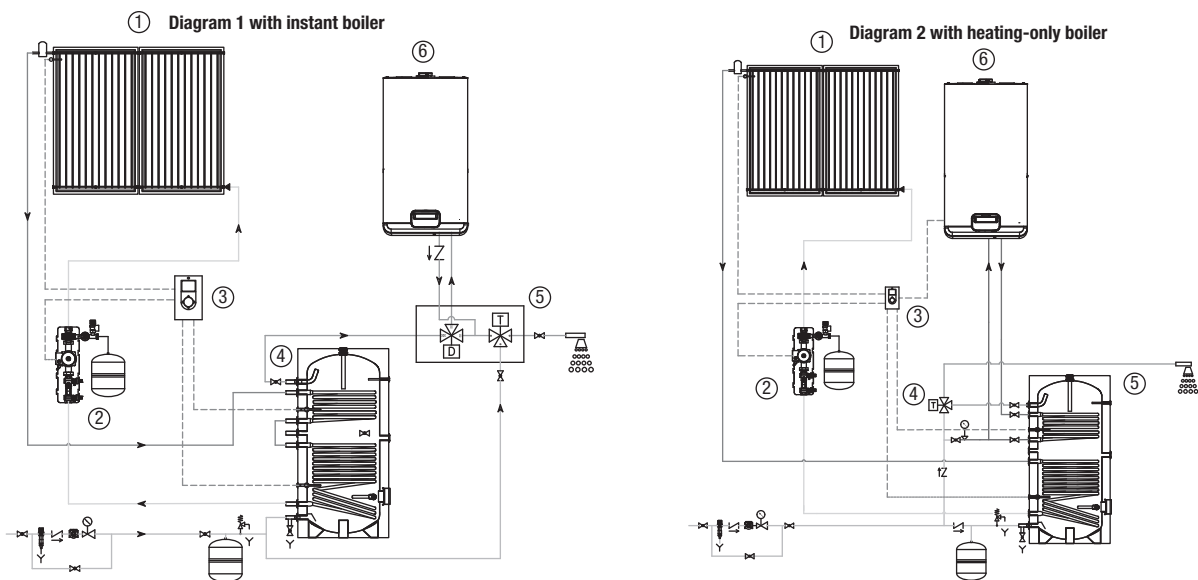

Basic layouts purely for illustrative purposes

1. Flat solar collectors
2. Return-only solar hydraulic unit
3. EVOSOL solar control unit
4. DHW double-coil cylinder
5. DHW diverting/mixing valve
6. Combined condensing boiler

1. Flat solar collectors
2. Return-only solar hydraulic unit
3. EVOSOL solar control unit
4. DHW mixing valve
5. DHW double-coil cylinder
6. Condensing boiler for heating only

## Flat solar collector SCF-20B



### flat solar collector for forced circulation

**high efficiency ensured by the aluminium absorber with highly selective surface**

**sealing between glass and frame with sealing material, without seal**

**ultrasonic welded copper pipes**

**stagnation temperature 192 °C**

**total surface of 1.91 m<sup>2</sup>**

**30 mm rock wool insulation**

**possibility to connect up to 6 collectors in series**

**wide range of accessories to facilitate installation**

**reduced assembly time thanks to simple and reliable fastening systems**

**solar collectors conforming to UNI-EN 12975 standards and Solar Keymark certification **

**5-year warranty**

The SCF-20B flat solar collector has 4 connections and is made up of an aluminium structure on which a two-piece aluminium capturing plate is fixed, with a highly selective finish carried out by means of a vacuum treatment called "TiNOX", which ensures very high collector performance.

The capturing plate is ultrasonic-welded on 10 copper tubes for the conduction of the heat transfer fluid.

The two main collectors, for the connection of the pipes, are made of copper: the heat transfer fluid is distributed in parallel in the 10 pipes that make up the absorber.

Each collector is protected by tempered solar glass with a low iron oxide content and a high energy transmission coefficient.

The 3 cm thick rock wool insulation is placed at the bottom of the tank.

The temperature sensor is placed in a special copper pocket.

The mounting system is simple and, if installation is carried out correctly, it guarantees effective and long-lasting operation.

## Flat solar collector SCF-20B

## Technical data sheet

Description	Unit	SCF-20B
AG gross surface	m <sup>2</sup>	1.89
Aa opening surface	m <sup>2</sup>	1.77
Effective absorber surface	m <sup>2</sup>	1.76
Energy Qcol (50°C) **	kWh/year	731
Energy Qcol (75°C) **	kWh/year	423
Specific productivity **	kWh/m <sup>2</sup> year	386.16
Connections (copper pipe)		4 × 1" (2M + 2F)
Empty weight	kg	30
Liquid content	litres	1.5
Recommended flow rate per m <sup>2</sup> of collector (*)	l/h	30
Type of glass - Thickness		safety glass with anti-reflection surface - 3.2 mm
Absorption (α)	%	~ 95
Emissions (ε)	%	~ 4
Maximum allowed pressure	bar	10
Stagnation temperature	°C	192
Maximum number of collectors that can be connected in series	no.	6

\* Capacity per m<sup>2</sup> min-max: 20-200 l/h.

\*\* Data from report for Würzburg.

## Influence of wind and snow on collectors

Positioning height above ground	Wind speed	Mass in kg to secure a collector from wind lifting		Roof load capacity for wind, snow, weight of a collector	
		45° inclination	20° inclination	45° inclination	20° inclination
0-8 m	100 km/h	80 kg	40 kg	320 kg	345 kg
8-20 m	130 km/h	180 kg	90 kg	470 kg	430 kg
20-100 m	150 km/h	280 kg	150 kg	624 kg	525 kg

Maximum permissible load on the surface of the collector due to wind and snow: 1500 Pa.

Connection pipe diameter with specific flow rate of 30 litres/m<sup>2</sup>h

Total surface area (m <sup>2</sup> )	2 - 4	6 - 12	14 - 20
Copper diameter (mm)	10 - 12	14	18
Steel diameter	3/8" - 1/2"	1/2"	3/4"

## Efficiency curves

Optical efficiency at absorber (η <sub>0</sub> )	Coefficients of heat loss of the absorber		IAM (50°)	Collector efficiency (η <sub>col</sub> )
	a1 W/(m <sup>2</sup> K)	a2 W/(m <sup>2</sup> K <sup>2</sup> )		
0.781 (1)	4.98 (1)	0.0005 (1)	0.87 (1)	0.579 (2)

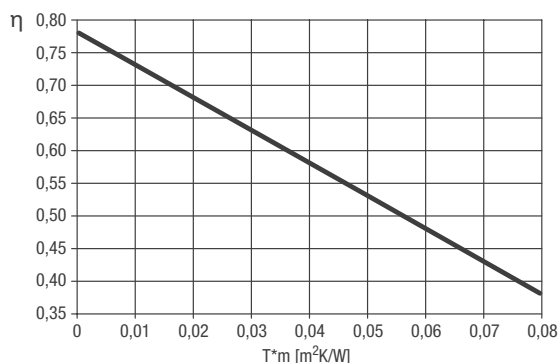

(1) Test according to EN 12975 referred to 33.3% water-glycol mixture, flow rate of 140 litres/h and radiation of  $G = 800 \text{ W/m}^2$ .

$$T_m = (T_{IN \text{ collector}} + T_{OUT \text{ collector}}) / 2$$

$$T^*_m = (T_m - T_{\text{ambient}}) / G$$

(2) (\*\*\*) Calculated at a temperature difference of 40 K between the solar collector and the surrounding ambient air, with a total solar radiation, referred to the opening area, of  $1000 \text{ W/m}^2$ .

### Flat solar collector SCF-20B

## Overall dimensions and structural parts

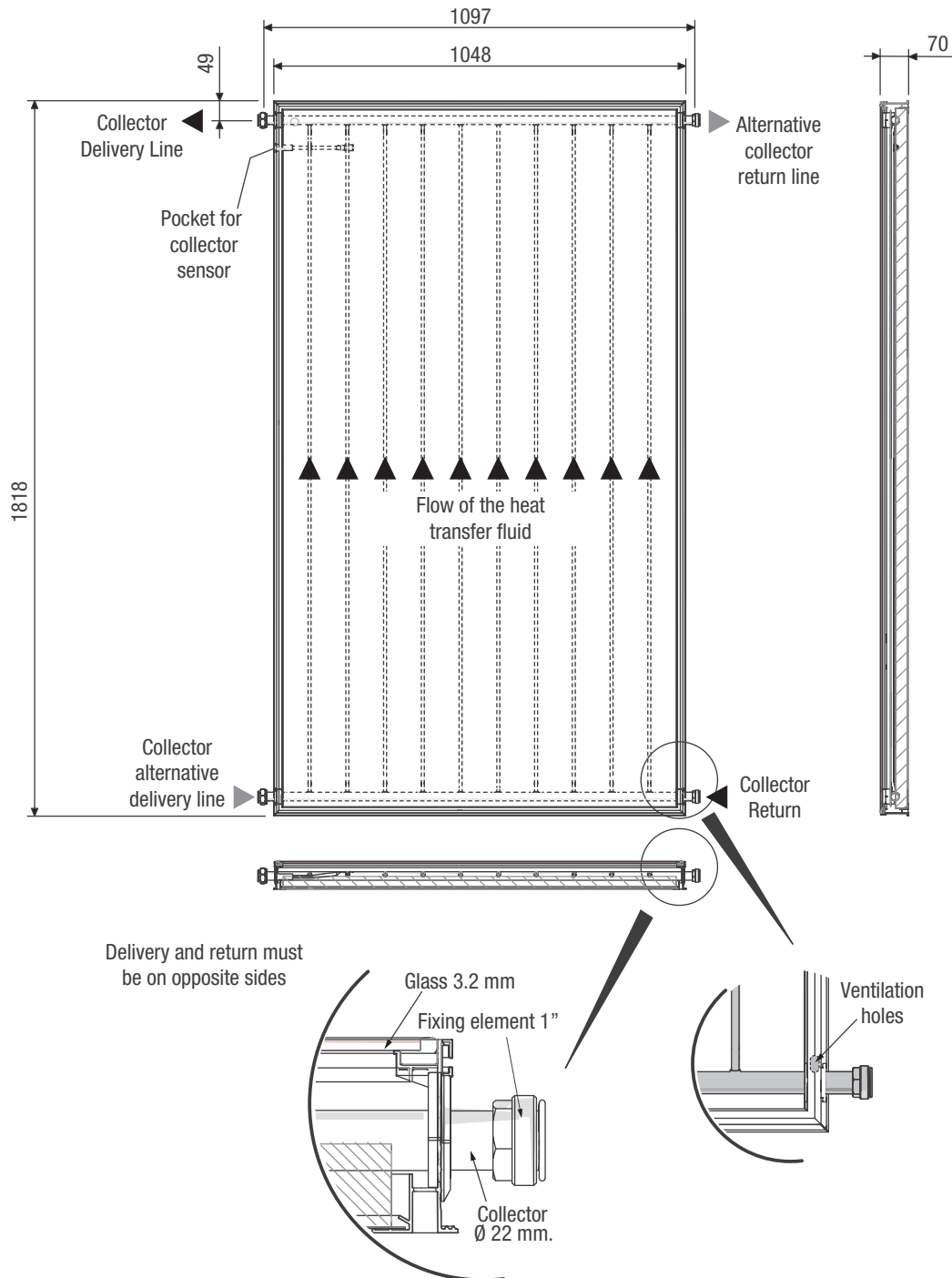

## Flat solar collector SCF-20B

### Hydraulic circuit

The following hydraulic diagram shows the connection between the solar collectors and the solar cylinder. Connect a maximum of 6 collectors in series. If copper pipes are used, solder by brazing. It is recommended to use stainless steel pipes suitable for solar systems (delivery, return and tube for the sensor).

A shielded cable is recommended for the sensor. Do not use plastic or multilayer pipes: the operating temperature can exceed 180 °C. The insulation of the pipes must withstand high temperatures (180 °C).

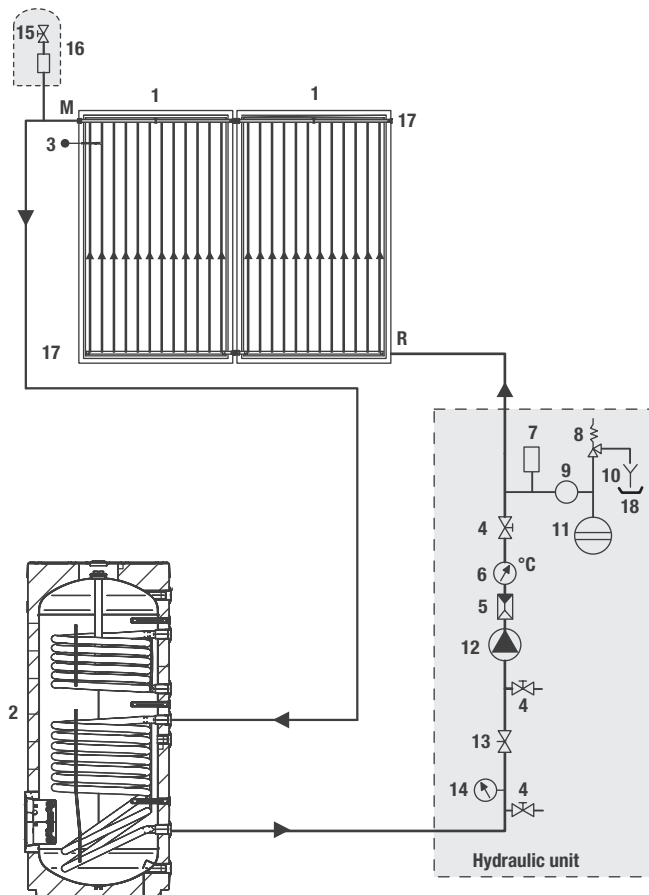

- 1. Solar collector
- 2. Cylinder
- 3. Collector sensor
- 4. Shut-off valves
- 5. Non-return valve
- 6. Thermometer
- 7. Breather valve
- 8. Safety valve
- 9. Pressure gauge
- 10. Discharge
- 11. Expansion vessel
- 12. Circulation pump
- 13. Flow regulator
- 14. Flowmeter
- 15. Drain cock
- 16. Manual degasser (accessory)
- 17. Plugs
- 18. Heat transfer fluid recovery

- M Collector delivery line
- R Collector return line

### Solar collector pressure drop

33.3% / 66.7% anti-freeze/water mixture and heat transfer fluid temperature = 20 °C.

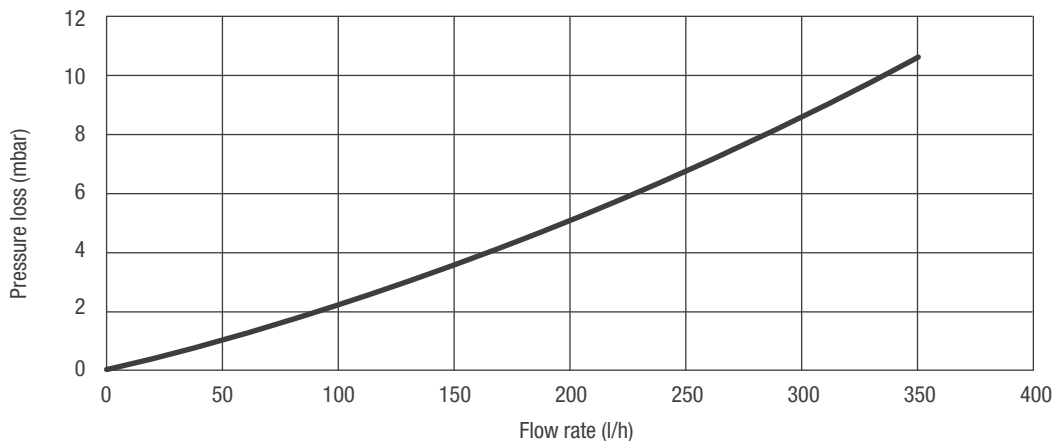

## Flat solar collector SCF-20B

### Positioning the sensors

The temperature sensor must be mounted in the pocket closest to the collector delivery pipe. Ensure optimal contact between sensor and pocket. Only materials with adequate temperature resistance

(up to 250 °C for sensor element, cables, sealing materials, insulation) can be used for sensor installation.

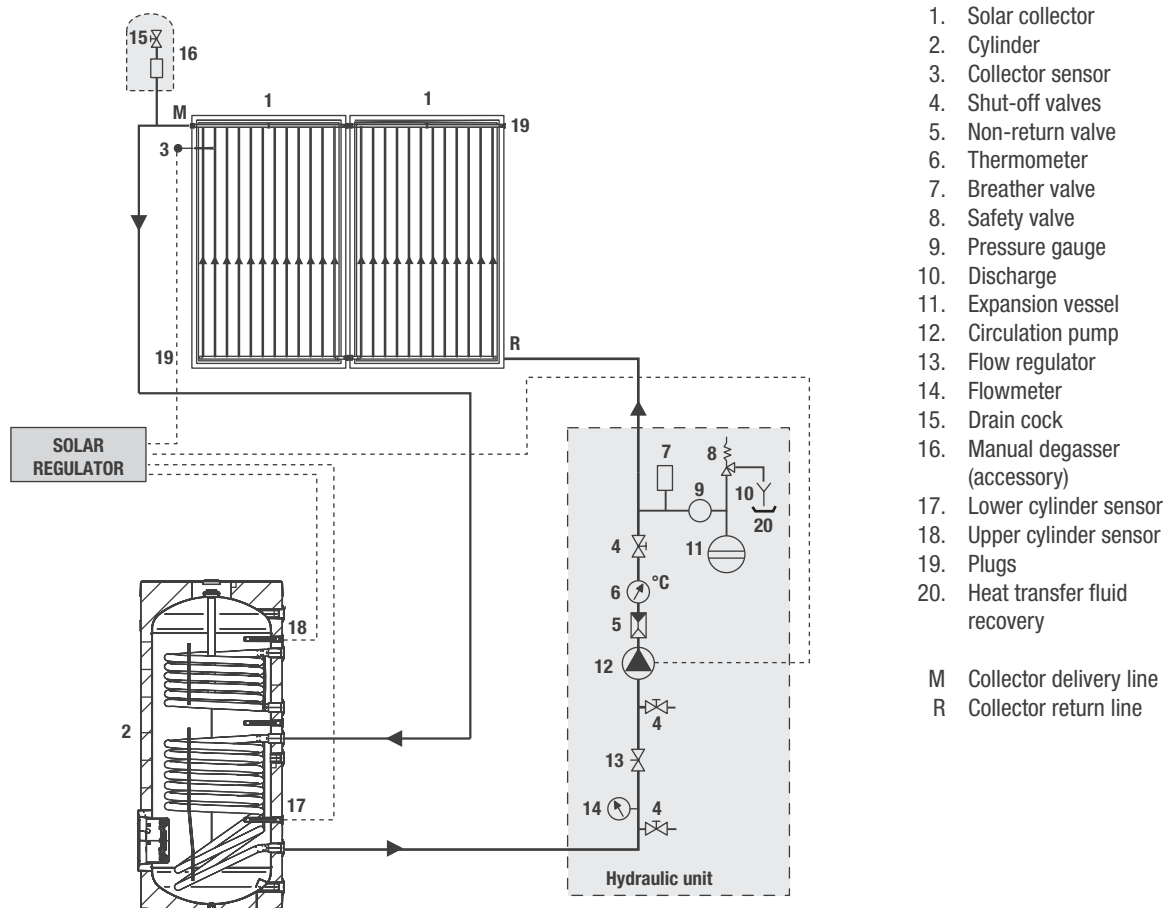

## Installation

### Instructions for installation

Installation may only be carried out by qualified personnel. Only the material included in the scope of supply may be used. The frame and its connections to the masonry parts must be checked by a structural engineer according to the circumstances on site.

### Static features

Only install on sufficiently strong roof surfaces or frames. The strength of the roof or frame must be checked on site by a structural engineer before installing the collectors. In this process, the suitability of the frame for the sealing of screw connections for the fastening of the collectors must be checked. The entire frame must be checked by a structural engineer in accordance with the regulations in force, especially in areas with heavy snowfall or in areas exposed to strong winds. All the characteristics of the installation site (gusts of wind, formation of vortices, etc.), which can lead to increased loads on the structures, must therefore be taken into account.

### Lightning protection

Solar circuit metal ducts must be connected through a (yellow-green) conductor of at least 16 mm<sup>2</sup> Cu (H07 V-U or R) to the potential compensation main bar. If a lightning rod is already installed, collectors can be integrated in the existing system. If this is not the case, it is possible to carry out earthing with a buried earth cable. The earth duct must be laid outside the house. Furthermore, the earth cable must be connected to the compensation bar through a duct having the same diameter.

### Connections

Collectors must be connected in series through connectors and seals. If hoses as connection elements are not provided, it is necessary to provide connection ducts with suitable devices for compensation of deformations caused by temperature inversions (expansion joints, hoses). When tightening the fitting with pliers or wrench it is necessary to hold the other fitting with a second wrench in order not to damage the absorber.

## Flat solar collector SCF-20B

All the pipes in the hydraulic circuit must be insulated in accordance with the regulations in force. Insulators must be protected against weather and attacks by animals.

### Collector inclination / Overview

The collector is suitable for an inclination of minimum 15°, up to a maximum of 75°. The ventilation and venting openings of the collectors must not be closed when installing the system. All connections of the collectors as well as the ventilation and vent holes must be protected from impurities such as dust deposits, etc. In systems with mainly summer load (production of domestic hot water), aim the collector from east to west and with an inclination varying from 20 to 60°. The ideal direction is southwards, with inclination equal to the latitude of the location -10°. In system with mainly winter load (systems that integrate domestic hot water production and space heating), aim the solar collector towards the south (south-east, south-west) with an inclination greater than 35°. The ideal direction is southwards, with inclination equal to the latitude of the location +10°.

### Flushing and filling

For safety reasons, filling should only be carried out when there is no sunlight. In areas subject to frost, it is necessary to use a 40% glycol solution for flat collectors.

The antifreeze must be mixed with water before filling.

If the system is flushed before filling the antifreeze, pay attention to any water deposits in the collector that may freeze.

### Vent

Venting must be carried out:

- At the time of commissioning (after filling).
- If necessary, e.g. in the event of a fault.

Carefully make sure that the system is completely vented.

Risk of burns with liquid in the collectors.

Only operate the vent valve if the temperature of the heat transfer fluid is below 60 °C.

### Check of the heat transfer fluid

The heat transfer fluid must be checked every 2 years to verify its antifreeze characteristics and its pH value.

Check the antifreeze with a suitable tool, refractometer or densimeter (nominal value approx. -30 °C): if the limit value of -26 °C is exceeded, change or add antifreeze

Check the pH value with litmus paper (nominal value approx. 7.5): if the measured value is below the limit value of 7, we recommend replacing the mixture.

### Water+glycol pre-mixing

The glycol is supplied separately in standard packages and must be mixed with water in a container before filling the system (for example 40% glycol and 60% water allow a resistance to frost up to -21 °C).

- The propylene glycol supplied is specifically designed for solar applications as it retains its characteristics in the range of -32 ÷ 180 °C. It is also non-toxic, biodegradable and biocompatible.
- Do not fill pure glycol into the system and then add water.
- Do not use manual or automatic filling systems.
- If the chlorine content is very high, distilled water must be used for the mixture.

50%	-32 °C	1.045 kg/dm <sup>3</sup>
40%	-21 °C	1.037 kg/dm <sup>3</sup>
30%	-13 °C	1.029 kg/dm <sup>3</sup>

## System filling

1. Open the non-return valve (A).
2. Open the air vent at the highest point (see figure) and keep it open throughout the filling operation.
3. Open the breather valve (7).
4. Circulate the heat transfer fluid with an external pump until all air bubbles are eliminated. Close the manual degasser valve.
5. Briefly increase the system pressure to 4 bar.
6. Start up the system for about 20 minutes.
7. Repeat the air bleeding operation from point 2 until the system is completely de-aerated.
8. Set the system pressure to 3 bar.
9. Close the non-return valve (A) and the air vents previously opened to prevent any evaporation of the heat transfer fluid.

Do not fill the system with strong sunlight and collectors at high temperature.

Make sure that the air bubbles are completely eliminated by also using the vent on the hydraulic unit.

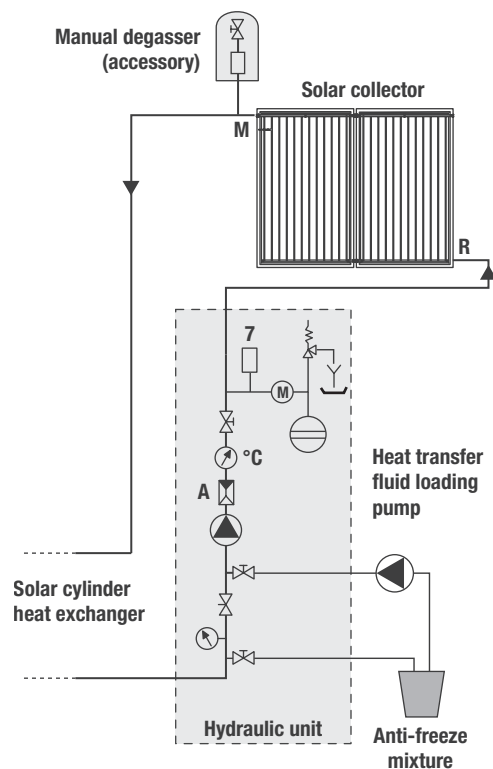

Antifreeze	Temperature	Density
------------	-------------	---------

**Flat solar collector SCF-20B**

# Kit for mounting collectors on flat roof 45°

**Mounting system components**

Code 20095379 - Flat collector SCF-20B	Number of collectors					
	1	2	3	4	5	6
<b>A</b> - Code 20087442 - Support bars 1 collector	1	-	-	-	-	-
<b>B</b> - Code 20087443 - Support bars 2 collectors	-	1	-	2	1	-
<b>C</b> - Code 20087444 - Support bars 3 collectors	-	-	1	-	1	2
<b>D</b> - Code 20087435 - Support bars 1-2 collectors	1	1	-	2	1	-
<b>E</b> - Code 20087436 - Fastening system 3 collectors	-	-	1	-	1	2
<b>F</b> - Code 20093048 - Coupling joints	-	-	-	1	1	1
<b>G</b> - Code 20094627 - End fitting kit	1	1	1	1	1	1
<b>H</b> - Code 20093047 - Collector locking kit	1	2	3	4	5	6

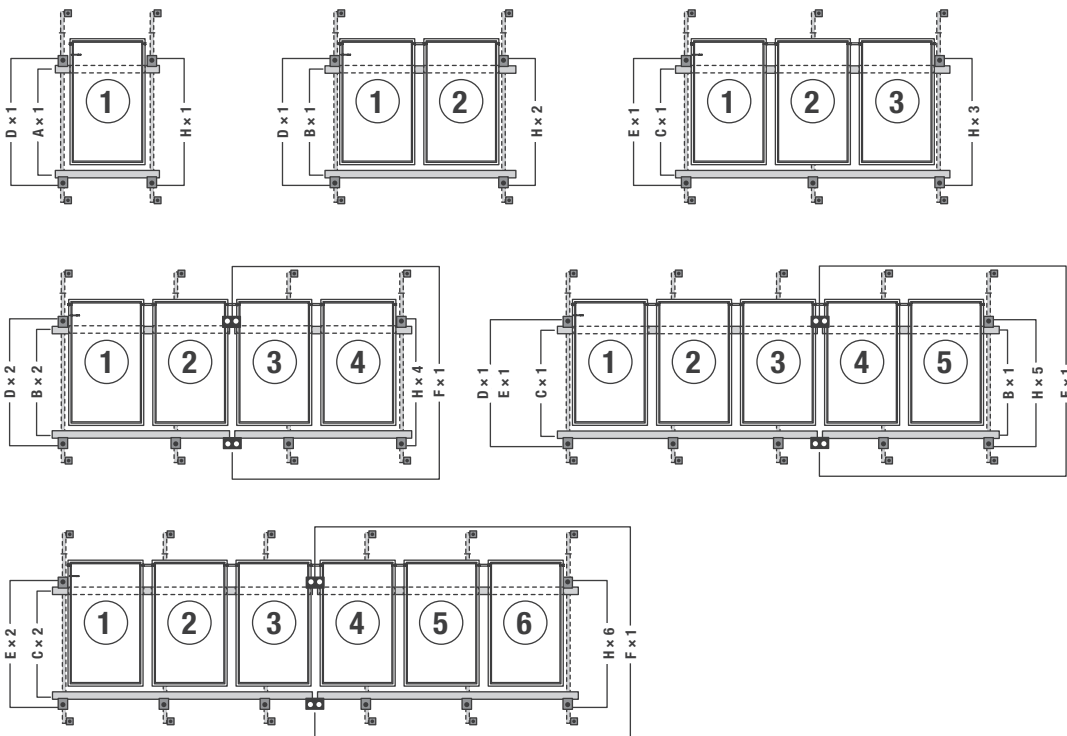

### Flat solar collector SCF-20B

## Kit for fixing collectors on sloping roofs

Code 20095379 - Flat collector SCF-20B	Mounting system components					
	Number of collectors					
	1	2	3	4	5	6
<b>A</b> - Code 20087442 - Support bars 1 collector	1	-	-	-	-	-
<b>B</b> - Code 20087443 - Support bars 2 collectors	-	1	-	2	1	-
<b>C</b> - Code 20087444 - Support bars 3 collectors	-	-	1	-	1	2
<b>D</b> - Code 20087433 - Support bars 1-2 collectors	1	1	-	2	1	-
<b>E</b> - Code 20087434 - Fastening system 3 collectors	-	-	1	-	1	2
<b>F</b> - Code 20093048 - Coupling joints	-	-	-	1	1	1
<b>G</b> - Code 20094627 - End fitting kit	1	1	1	1	1	1
<b>H</b> - Code 20093047 - Collector locking kit	1	2	3	4	5	6

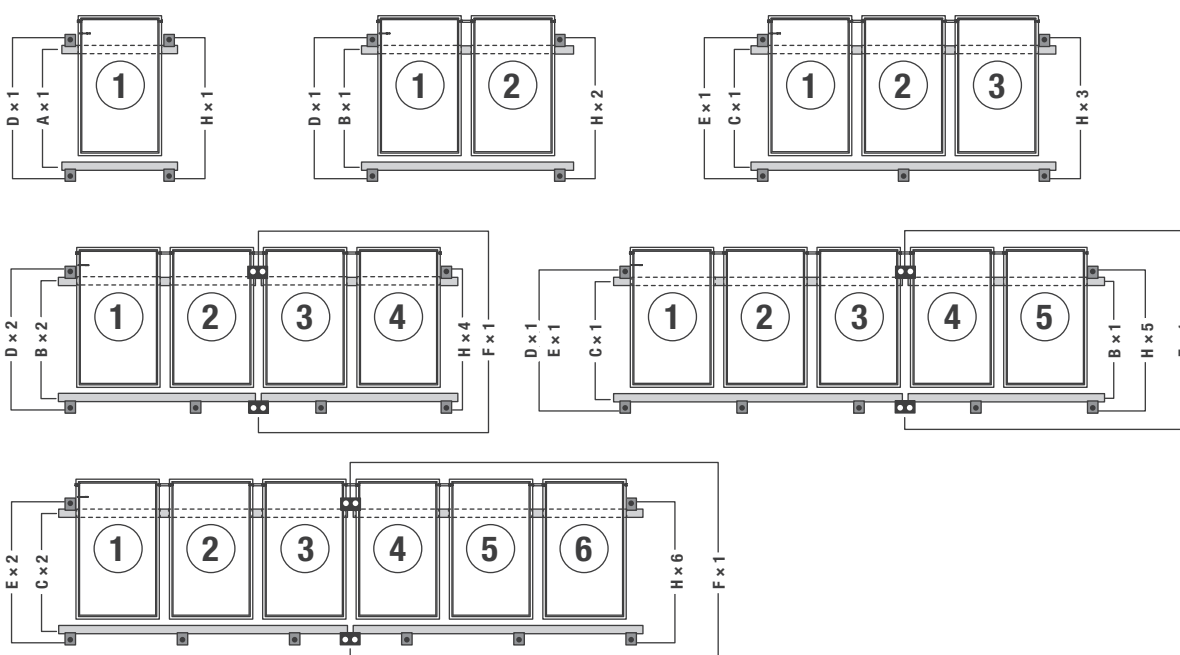

## Undertile fastening option

If you prefer not to drill the roof tiles, you can use an undertile fastening kit.

Code 20095379 - Flat collector SCF-20B	Components of the undertile fastening system (sloping roof)					
	Number of collectors					
	1	2	3	4	5	6
<b>A</b> - Code 20087442 - Support bars 1 collector	1	-	-	-	-	-
<b>B</b> - Code 20087443 - Support bars 2 collectors	-	1	-	2	1	-
<b>C</b> - Code 20087444 - Support bars 3 collectors	-	-	1	-	1	2
<b>D</b> - Code 20093049 - Support bars 1-2 collectors	1	1	-	2	1	-
<b>E</b> - Code 20093050 - Fastening system 3 collectors	-	-	1	-	1	2
<b>F</b> - Code 20093048 - Coupling joints	-	-	-	1	1	1
<b>G</b> - Code 20094627 - End fitting kit	1	1	1	1	1	1
<b>H</b> - Code 20093047 - Collector locking kit	1	2	3	4	5	6

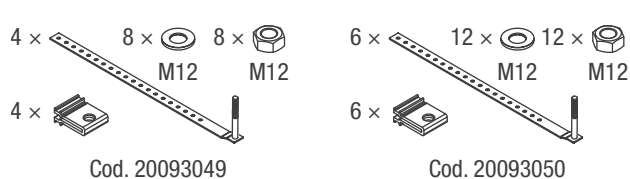

Kit of components for undertile fastening

### Flat solar collector SCF-20B

## Distance between fastening points

Always drill holes in the ridge of the roof tile or bent tile.

In the presence of a joint between rods, ensure at least one fastening point near the joint.

### Flat roof - Vertical 2.0 m<sup>2</sup> collector with frame

Number of vertical collectors (H = 201 cm)	1	2	3	4	5	6
Overall length L	110 cm	220 cm	330 cm	440 cm	550 cm	660 cm

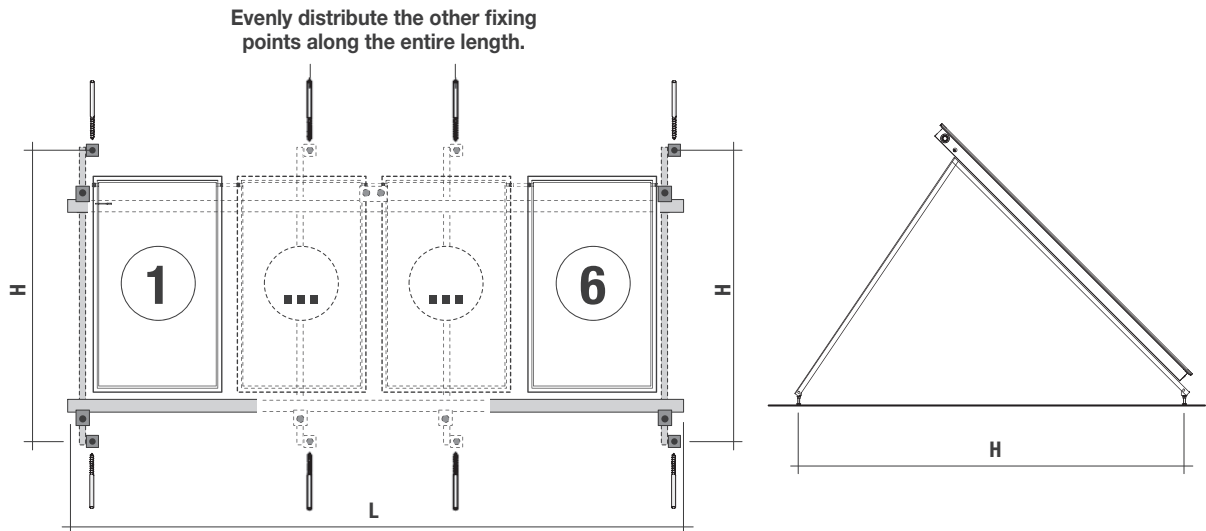

### Tilted roof - Vertical 2.0 m<sup>2</sup> collector with frame

Number of vertical collectors (H <sub>MIN</sub> = 145 cm - H <sub>MAX</sub> = 170 cm)	1	2	3	4	5	6
Overall length L	110 cm	220 cm	330 cm	440 cm	550 cm	660 cm

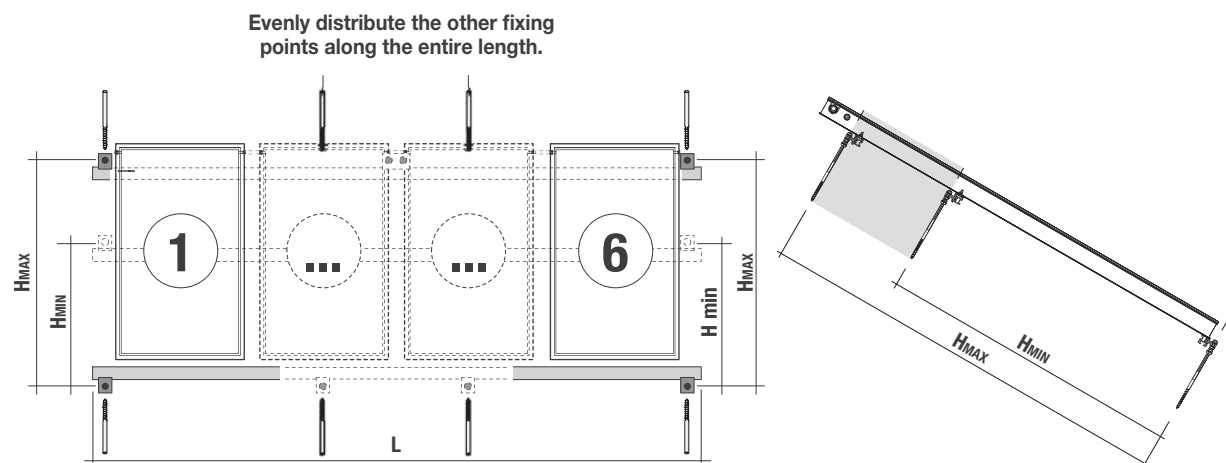

Flat solar collector SCF-20B

# Examples of installation

## Installation with wall-mounted heating-only boiler and double-coil cylinder

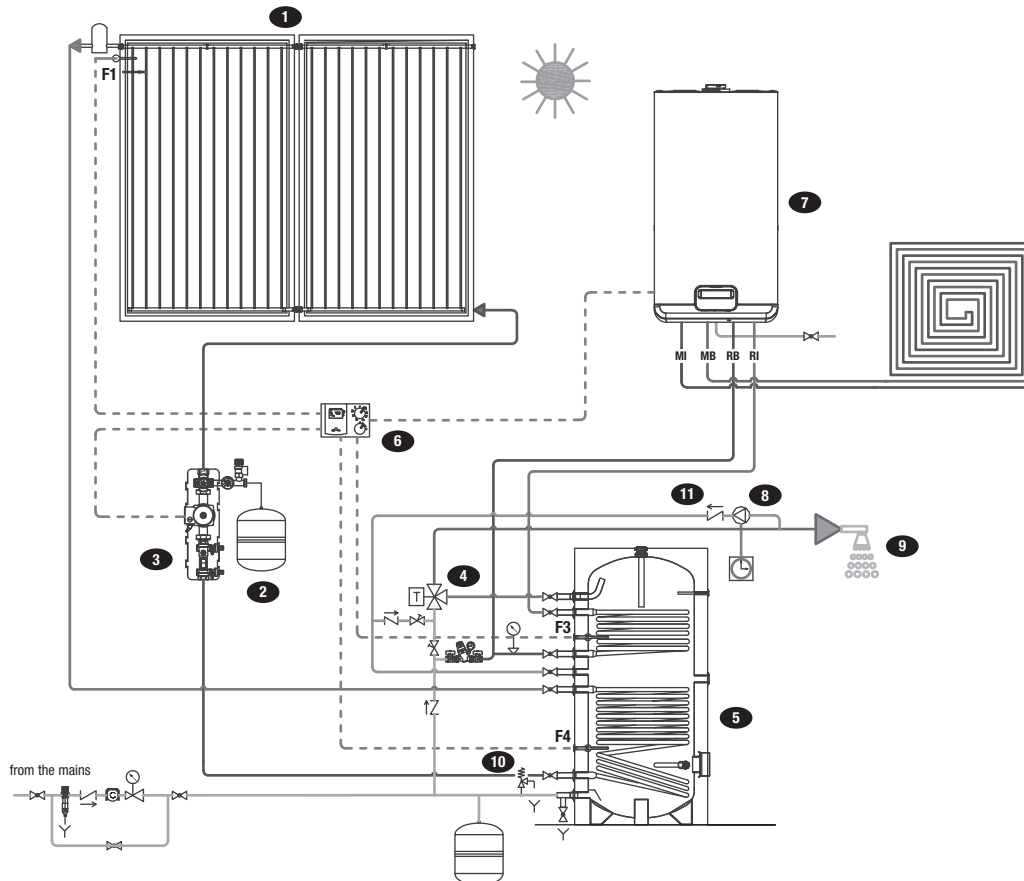

- |  |                           |
|--|---------------------------|
| 1. Solar collector SCF-20B                               | 10. Safety valve          |
| 2. Expansion vessel for solar circuit                    | 11. Non-return valve      |
| 3. Hydraulic return kit for solar system                 |                           |
| 4. Thermostatic mixing valve                             | MI System delivery line   |
| 5. Double-coil cylinder                                  | MB Cylinder delivery line |
| 6. SUN B solar control unit                              | RB Cylinder return line   |
| 7. Wall-mounted heating-only boiler with three-way valve | RI System return line     |
| 8. Circulating pump for DHW recirculation                | F1 Collector sensor       |
| 9. Utilities   | F3 Boiler request sensor  |
|  | F4 Cylinder sensor        |

**Flat solar collector SCF-20B**

**Installation with combined boiler and single-coil cylinder**

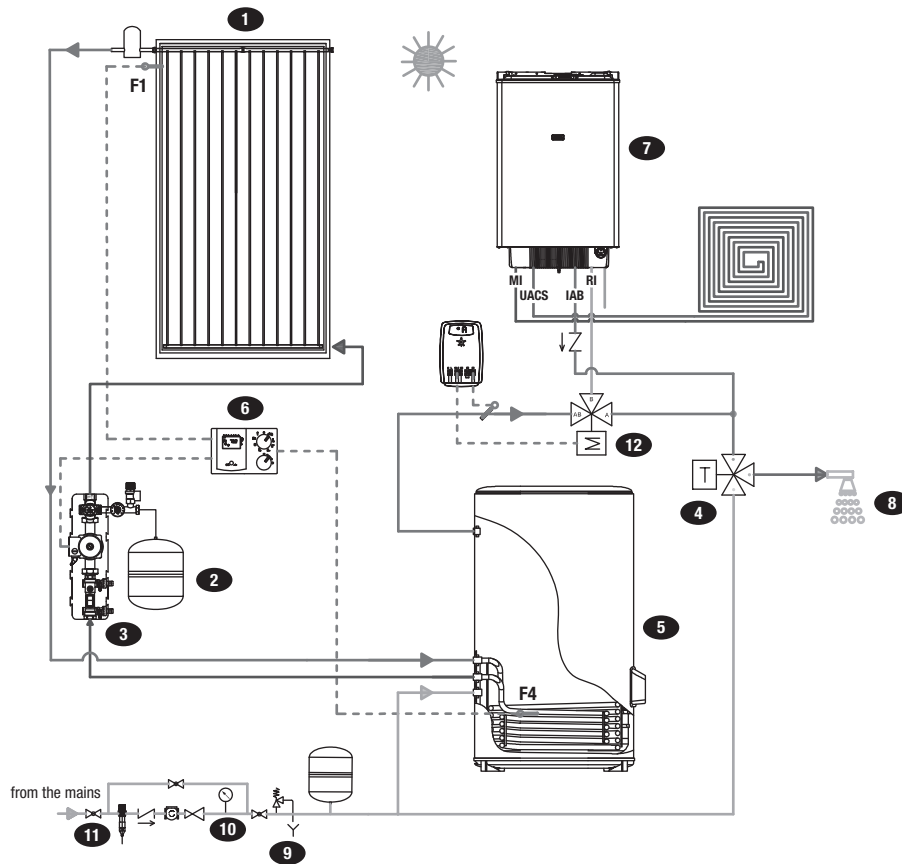

- |  |                                |
|--|--------------------------------|
| 1. Solar collector SCF-20B               | 11. Non-return valve           |
| 2. Expansion vessel for solar circuit    | 12. Motorised 3-way valve      |
| 3. Hydraulic return kit for solar system |                                |
| 4. Thermostatic mixer                    | MI System delivery line        |
| 5. Single-coil cylinder                  | IAB Water inlet from cylinder  |
| 6. SUN B solar control unit              | UACS Domestic hot water outlet |
| 7. Wall-mounted combined boiler          | RI System return line          |
| 8. Utilities                             | F1 Collector sensor            |
| 9. Safety valve                          | F4 Cylinder sensor             |
| 10. Pressure gauge                       |                                |

**Flat solar collector SCF-20B**

# Selection of components for the installation of solar systems with SCF-20B vertical flat collectors and IDRA cylinders

If you do not intend to use one of the SCF-20B solar packages (up to 4 SCF-20B collectors available), the following table indicates the hydraulic components necessary and optional to build a solar system with an array of SCF-20B collectors. The control unit and the boiler must be selected separately according

to the requirements. The configurations shown below refer to standard solar systems: special exposures and inclinations of the collectors, as well as considerable distances between collectors and cylinder, can change the choice of the most suitable component.

		Number of collectors								
		1	2	3	4	5	6	8	10	12
Code 20095379	SCF-20B vertical flat collector	1	-	1	-	1	-	-	-	1
Code 20095380	SCF-20B vertical flat collector (pack of 2 pcs)	-	1	1	2	2	3	4	5	2
Code 20095381	SCF-20B vertical flat collector (pack of 7 pcs)	-	-	-	-	-	-	-	-	1
Code 20117881	Double-coil cylinder IDRA DS 200	1	1	-	-	-	-	-	-	-
Code 20119552	Double-coil cylinder IDRA DS 200 FI	1 (a)	1 (a)	-	-	-	-	-	-	-
Code 20117882	Double-coil cylinder IDRA DS 300	-	-	1	-	-	-	-	-	-
Code 20119553	Double-coil cylinder IDRA DS 300 FI	-	-	1 (a)	-	-	-	-	-	-
Code 20117883	Double-coil cylinder IDRA DS 430	-	-	-	1	-	-	-	-	-
Code 20119554	Double-coil cylinder IDRA DS 430 FI	-	-	-	1 (a)	-	-	-	-	-
Code 20117884	Double-coil cylinder IDRA DS 550	-	-	-	-	1	-	-	-	-
Code 20119555	Double-coil cylinder IDRA DS 550 FI	-	-	-	-	1 (a)	-	-	-	-
Code 20117885	Double-coil cylinder IDRA DS 750	-	-	-	-	-	1	-	-	-
Code 20117886	Double-coil cylinder IDRA DS 1000	-	-	-	-	-	-	1	-	-
Code 20136241	Double-coil cylinder IDRA N DS 1500	-	-	-	-	-	-	-	1 (b)	-
Code 20136242	Double-coil cylinder IDRA N DS 2000	-	-	-	-	-	-	-	-	1 (b)
Code 20116161	Connect Solar MR - 7.5 m	1 (c)	1 (c)	1 (c)	1 (c)	1 (c)	1 (c)	1 (c)	1 (c)	1 (c)
Code 20075392	Hydraulic unit for delivery and return lines H 14.5 mH2O	1 (c)	1 (c)	1 (c)	1 (c)	1 (c)	1 (c)	1 (c)	1 (c)	1 (c)
Code 1150489	18-litre expansion vessel	1	1	1	-	-	-	-	-	1
Code 1150509	24-litre expansion vessel	-	-	-	1	1	-	-	-	-
Code 1150519	35-litre expansion vessel	-	-	-	-	-	1	1	-	-
Code 20001448	50-litre expansion vessel (d)	-	-	-	-	-	-	-	1	1
Code 1150499	Wall-mounting bracket for 18 and 24-litre vessels (e)	1	1	1	1	1	-	-	-	1
Code 20009190	Glycol 2.5 kg	1	1	1	-	-	-	-	-	-
Code 1150549	Glycol 5 kg	1	1	1	-	-	1	1	-	-
Code 1150559	Glycol 10 kg	-	-	-	1	1	1	1	2	3
Code 1150529	¾" thermostatic mixing valve	1	1	1	1	1	-	-	-	-
Code 20026577	Manual degasser (f)	1	1	1	1	1	2	2	2	3

- (a) IDRA DS FI cylinders shall be chosen as an alternative to IDRA DS models of equal capacity.
- (b) The number of collectors SCF-20B to be applied to IDRA N DS 1500/2000 cylinders must be carefully calculated according to the specific situation.
- (c) Not required with IDRA DS FI cylinders. The hydraulic unit code 20075392 should be chosen as an alternative to code 20116161 if the head of the latter is not sufficient.
- (d) The number of SCF-20B collectors to be applied with 50-litre expansion vessels shall be calculated according to the specific situation.
- (e) Optional accessory.
- (f) One per array. Not necessary if the system is filled with a centrifugal pump (code 20001454).

Mounting brackets for flat roofs		Number of collectors								
		1	2	3	4	5	6	8 (g)	10 (h)	12 (i)
Code 20087442	Support rod kit for 1 collector	1	-	-	-	-	-	-	-	-
Code 20087443	Support rod kit for 2 collectors	-	1	-	2	1	-	4	2	-
Code 20087444	Support rod kit for 3 collectors	-	-	1	-	1	2	-	2	4
Code 20087435	Fixing system for 1-2 collectors	1	1	-	2	1	-	4	2	-
Code 20087436	Fixing system for 3 collectors	-	-	1	-	1	2	-	2	4
Code 20093048	Coupling joints	-	-	-	1	1	1	2	2	2
Code 20094627	Terminal connection kit	1	1	1	1	1	1	2	2	2
Code 20093047	Collector locking kit	1	2	3	4	5	6	8	10	12

Mounting brackets for slanting roofs		Number of collectors								
		1	2	3	4	5	6	8 (g)	10 (h)	12 (i)
Code 20087442	Support rod kit for 1 collector	1	-	-	-	-	-	-	-	-
Code 20087443	Support rod kit for 2 collectors	-	1	-	2	1	-	4	2	-
Code 20087444	Support rod kit for 3 collectors	-	-	1	-	1	2	-	2	4
Code 20087433	Fixing system for 1-2 collectors	1	1	-	2	1	-	4	2	-
Code 20087434	Fixing system for 3 collectors	-	-	1	-	1	2	-	2	4
Code 20093048	Coupling joints	-	-	-	1	1	1	2	2	2
Code 20094627	Terminal connection kit	1	1	1	1	1	1	2	2	2
Code 20093047	Collector locking kit	1	2	3	4	5	6	8	10	12

- (g) 2 arrays of 4+4 collectors are considered.
- (h) 2 arrays of 5+5 collectors are considered.
- (i) 2 arrays of 6+6 collectors are considered.

## Flat solar collector SCF-20B

# Selection of components for the installation of solar systems with SCF-20B vertical flat collectors and STOR inertial buffer tanks

Table showing the hydraulic components needed and optional to build a solar system with an array of SCF-20B collectors.

The control unit and the boiler must be selected separately according to the requirements.

The configurations shown below refer to standard solar systems: special exposures and inclinations of the collectors, as well as considerable distances between collectors and cylinder, can change the choice of the most suitable component.

		Number of collectors					
		2	4	8	10	14	20
Code 20095379	SCF-20B vertical flat collector	-	-	1	-	-	-
Code 20095380	SCF-20B vertical flat collector (pack of 2 pcs)	1	2	-	5	-	3
Code 20095381	SCF-20B vertical flat collector (pack of 7 pcs)	-	-	1	-	2	2
Code 20055207	Inertial buffer tank with coil STOR 300 M	1	-	-	-	-	-
Code 20055208	Inertial buffer tank with coil STOR 500 M	-	1	-	-	-	-
Code 20136264	Inertial buffer tank with coil STOR 1000 M	-	-	1	-	-	-
Code 20136265	Inertial buffer tank with coil STOR 1500 M	-	-	-	1	-	-
Code 20136258	Inertial buffer tank STOR 2000	-	-	-	-	1 (a)	-
Code 20001409	Inertial buffer tank STOR 3000	-	-	-	-	-	1 (a)
Code 20116161	Connect Solar MR - 7.5 m	1 (b)	1 (b)	1 (b)	1 (b)	1 (b)	1 (b)
Code 20075392	Hydraulic unit for delivery and return lines H 14.5 mH <sub>2</sub> O	1 (b)	1 (b)	1 (b)	1 (b)	1 (b)	1 (b)
Code 20001436	Solar heat exchange unit STS 50 LE	1 (c)	1 (c)	1 (c)	1 (c)	1 (c)	1 (c)
Code 20083491	DHW heat exchange unit ACS 40 LE	1 (c)	1 (c)	1 (c)	1 (c)	1 (c)	1 (c)
Code 20083492	DHW heat exchange unit ACS 160 LE	-	-	-	1 (c)	1 (c)	1 (c)
Code 1150489	18-litre expansion vessel	1	-	-	-	-	-
Code 1150509	24-litre expansion vessel	-	1	-	-	-	1
Code 1150519	35-litre expansion vessel	-	-	1	-	-	-
Code 20001448	50-litre expansion vessel (d)	-	-	-	1	1	1
Code 1150499	Wall-mounting bracket for 18 and 24-litre vessels (e)	1	1	-	-	-	1
Code 20009190	Glycol 2.5 kg	-	-	-	-	1	1
Code 1150549	Glycol 5 kg	1	1	1	-	1	-
Code 1150559	Glycol 10 kg	-	1	1	2	1	2
Code 20026577	Manual degasser (f)	1	1	2	2	3	4

- (a) The number of collectors SCF-20B to be applied with STOR 2000/3000 storage tanks must be carefully calculated according to the specific situation.
- (b) The hydraulic unit code 20075392 should be chosen as an alternative to code 20116161 if the head of the latter is not sufficient.
- (c) The DHW exchange units shall be selected on the basis of the DHW demand calculated by the designer.

- (d) The number of SCF-20B collectors to be applied with 50-litre expansion vessel shall be carefully calculated according to the specific situation.
- (e) Optional accessory.
- (f) One per array. Not necessary if the system is filled with a centrifugal pump (code 20001454).

		Number of collectors					
		2	4	8 (g)	10 (h)	14 (i)	20 (j)
Code 20087442	Support rod kit for 1 collector	-	-	-	-	-	-
Code 20087443	Support rod kit for 2 collectors	1	2	4	2	4	4
Code 20087444	Support rod kit for 3 collectors	-	-	-	2	2	4
Code 20087435	Fixing system for 1-2 collectors	1	2	4	2	4	4
Code 20087436	Fixing system for 3 collectors	-	-	-	2	2	4
Code 20093048	Coupling joints	-	1	2	2	3	4
Code 20094627	Terminal connection kit	1	1	2	2	3	4
Code 20093047	Collector locking kit	2	4	8	10	14	20

		Number of collectors					
		2	4	8 (g)	10 (h)	14 (i)	20 (j)
Code 20087442	Support rod kit for 1 collector	-	-	-	-	-	-
Code 20087443	Support rod kit for 2 collectors	1	2	4	2	4	4
Code 20087444	Support rod kit for 3 collectors	-	-	-	2	2	4
Code 20087433	Fixing system for 1-2 collectors	1	2	4	2	4	4
Code 20087434	Fixing system for 3 collectors	-	-	-	2	2	4
Code 20093048	Coupling joints	-	1	2	2	3	4
Code 20094627	Terminal connection kit	1	1	2	2	3	4
Code 20093047	Collector locking kit	2	4	8	10	14	20

- (g) 2 arrays of 4+4 collectors are considered.
- (h) 2 arrays of 5+5 collectors are considered.

- (i) 3 arrays of 5+5+4 collectors are considered.
- (j) 4 arrays of 5+5+5+5 collectors are considered.

# SCF-20/4B A and SCF-25/4B A vertical flat solar collectors

## Product description

The SCF A solar collectors, which can be installed in a vertical position, are equipped with a highly selective aluminium absorber with TiNO<sub>x</sub> treatment and a laser-welded harp consisting of 12 copper pipes with a diameter of 8 mm, which guarantee up to 95% absorption of the radiated solar energy.

- The solar glass is a tempered, prismatic type and ensures high transmissivity.
- The insulation is made of glass wool, 30 mm thick and is positioned in the bottom part. The glass and the insulation guarantee high performance levels even in less than optimal weather conditions.
- 4 x 1" compression fittings.
- Up to 10 collectors can be connected in series vertically.
- Solar Keymark certification.
- Wide range of accessories and fastening systems to ensure maximum versatility of installation.
- 5-year warranty.



## Technical data sheet

Description	Unit	SCF-20/4B A	SCF-25/4B A
Gross surface AG	m <sup>2</sup>	2,000	2,500
Opening surface Aa	m <sup>2</sup>	1,910	2,390
Actual absorber area	m <sup>2</sup>	1,900	2,370
Hydraulic connections	mm	22	22
Empty weight	kg	29,15	35,4
Liquid content	l	1,38	1,55
Recommended flow rate for each line per m <sup>2</sup> of collector (4)	l/(hxm <sup>2</sup> )	30	30
Maximum flow rate for each line per m <sup>2</sup> of collector	l/(hxm <sup>2</sup> )	20	20
Minimum flow rate for each line per m <sup>2</sup> of collector	l/(hxm <sup>2</sup> )	60	60
Glass thickness	mm	3,2	3,2
Thickness of glass wool insulation	mm	30	30
Absorption (α)	%	95	95
Emissivity (ε)	%	4	4
Maximum permitted pressure	bar	10	10
Stagnation temperature	°C	180	180
Maximum number of collectors in a line	n°	10	10
Installation	-	Vertical	Vertical
Würzburg Yield @ T <sub>m</sub> 25°C (3)	kWh/year	1470	1837
Würzburg Qcol Yield @ T <sub>m</sub> 50°C (3)	kWh/year	947	1184
Würzburg Qcol Yield @ T <sub>m</sub> 75°C (3)	kWh/year	522	652
Specific Producibility (3)	kWh/m <sup>2</sup> year	473,5	473,6
Optical efficiency (η <sub>0</sub> ) (1)	%	76,2	77
Heat loss coefficient (a1) (1)	W/(m <sup>2</sup> K)	2,99	3,18
Heat loss coefficient (a2) (1)	W/(m <sup>2</sup> K)	0,027	0,021
IAM (50°) (1)	-	0,91	0,91
Collector efficiency (η <sub>col</sub> ) (2)	%	60	60

(1) Value referred to the opening area. Test according to ISO 9806 referred to mix of water and 33.3% glycol, flow rate 160 l/h and direct exposure G = 800W/m<sup>2</sup>.

$T_m = (\text{Coll.}_{inlet\_temp.} + \text{Coll.}_{outlet\_temp.})/2$

$T^*m = (T_m - T_{ambient})/G$

(2) Calculated at a temperature difference between the solar collector and the surrounding ambient air equal to 40°K, with a global solar radiation of 1000 W/m<sup>2</sup>, referred to the opening area.

(3) Location: Würzburg; data from the test report of the collector.

(4) Recommended flow rate in the medium/cold climate range.

SCF-20/4B A and SCF-25/4B A vertical flat solar collectors

# Solar collectors pressure losses

Single panel load losses [33.3% glycol] - SCF-20/4B A

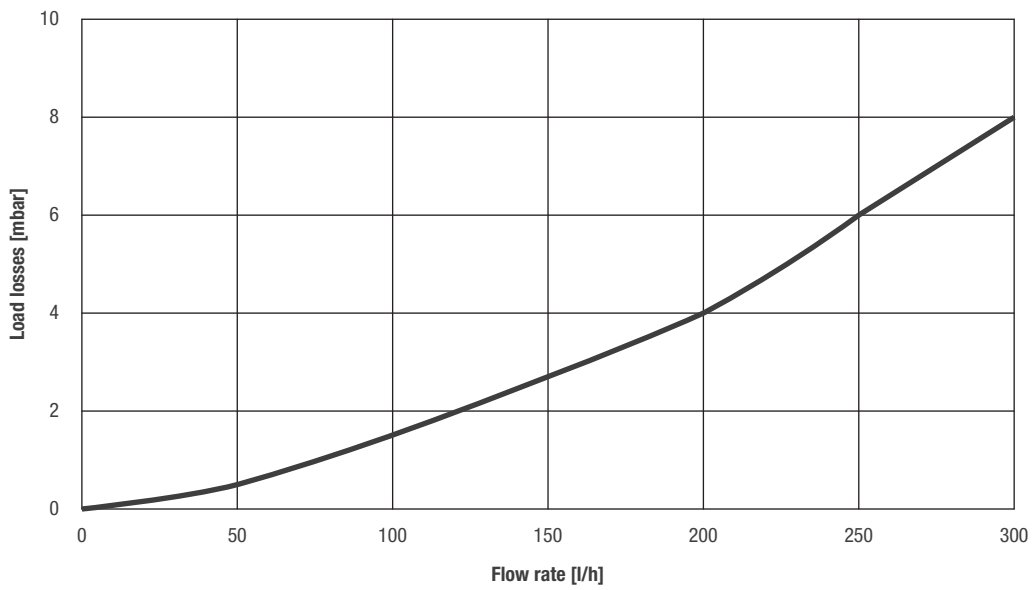

Single panel load losses [33.3% glycol] - SCF-25/4B A

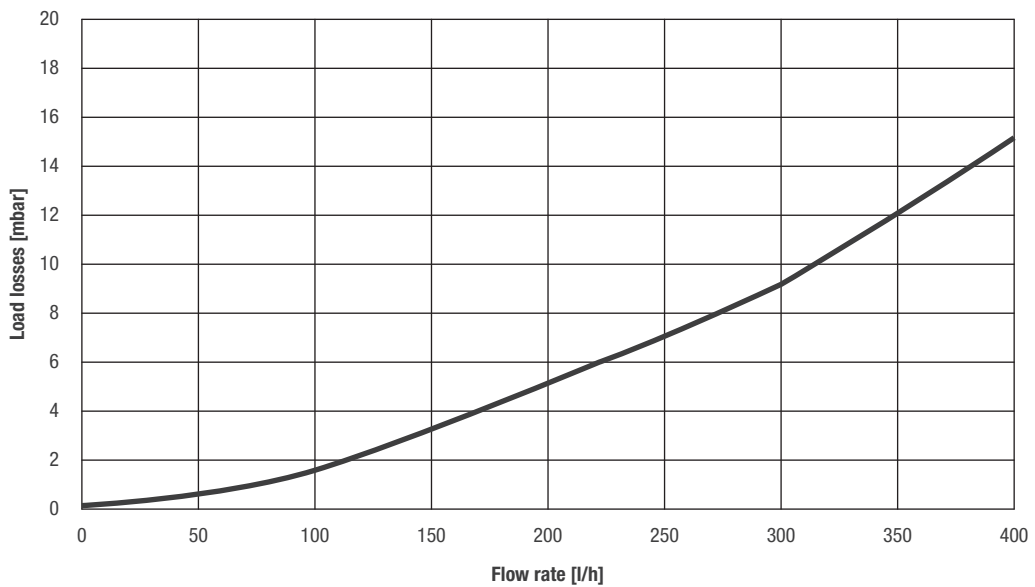

SCF-20/4B A and SCF-25/4B A vertical flat solar collectors

# Efficiency curve

Efficiency curve - SCF-20/4B A

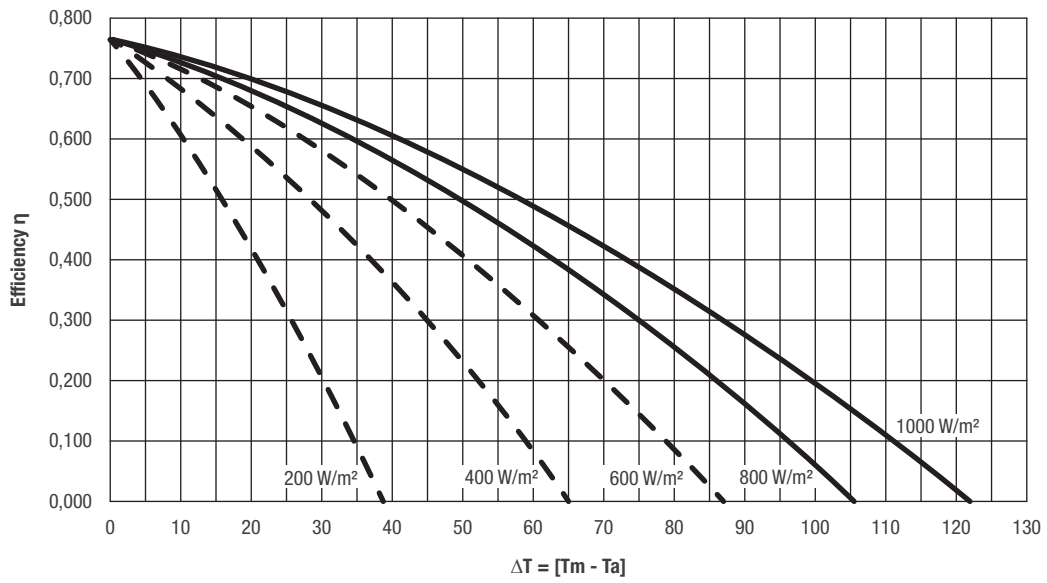

Efficiency curve - SCF-25/4B A

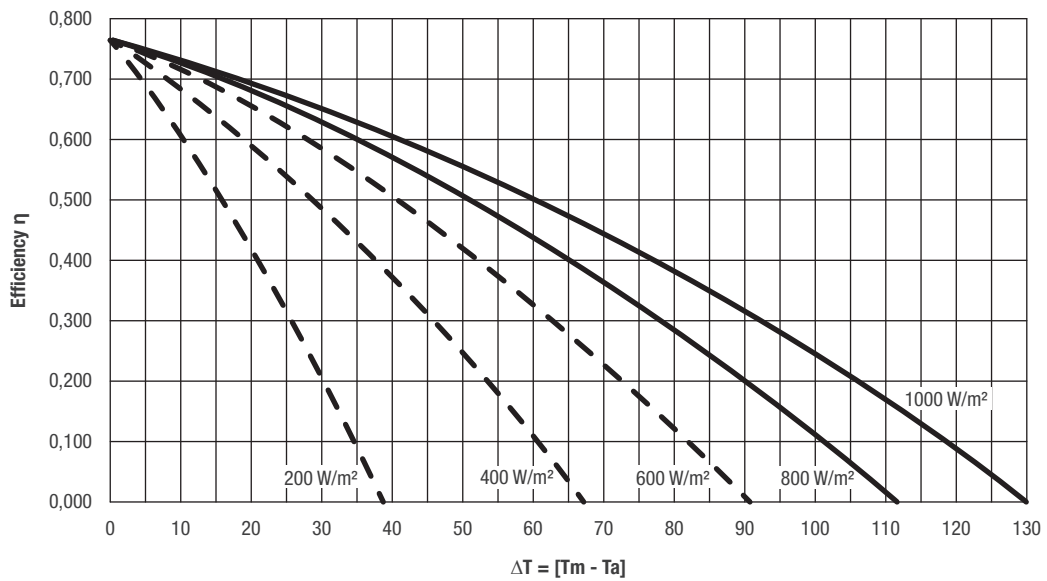

$T_m$  = average collector temperature  
 $T_a$  = external ambient temperature

SCF-20/4B A and SCF-25/4B A vertical flat solar collectors

# Output curve

Output curve - SCF-20/4B A

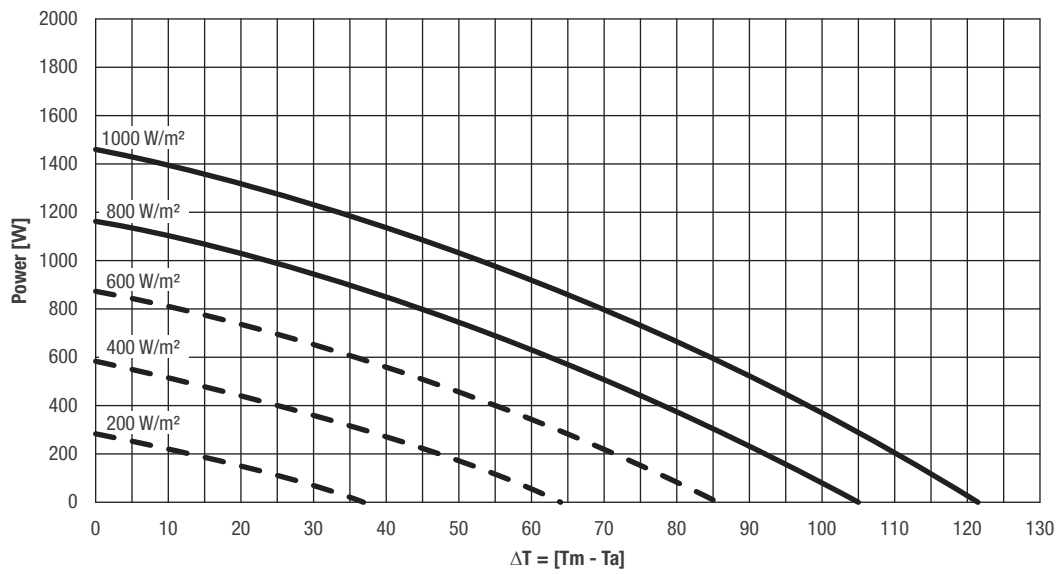

Output curve - SCF-25/4B A

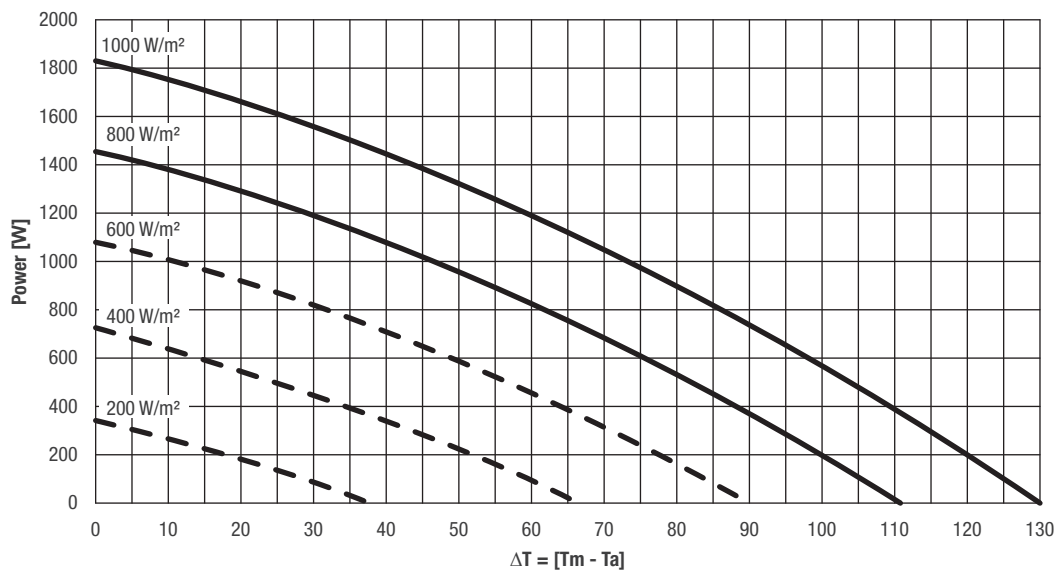

T<sub>m</sub> = average collector temperature  
 T<sub>a</sub> = external ambient temperature

### SCF-20/4B A and SCF-25/4B A vertical flat solar collectors

## Overall dimensions and structural parts

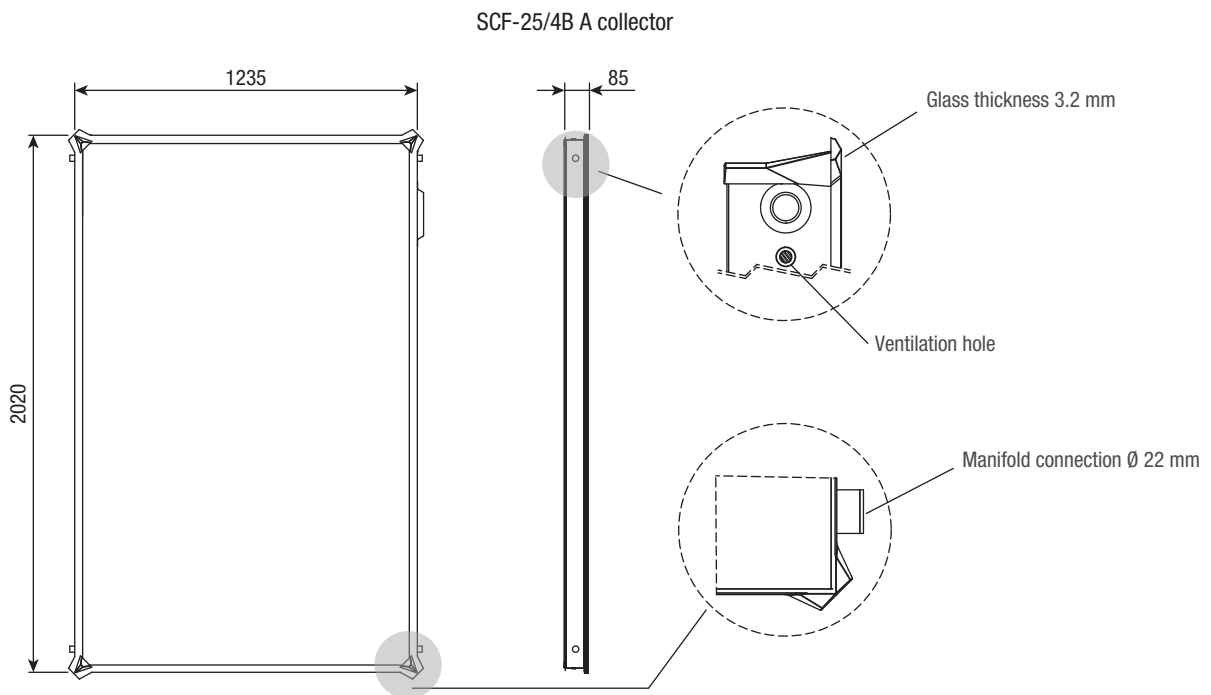
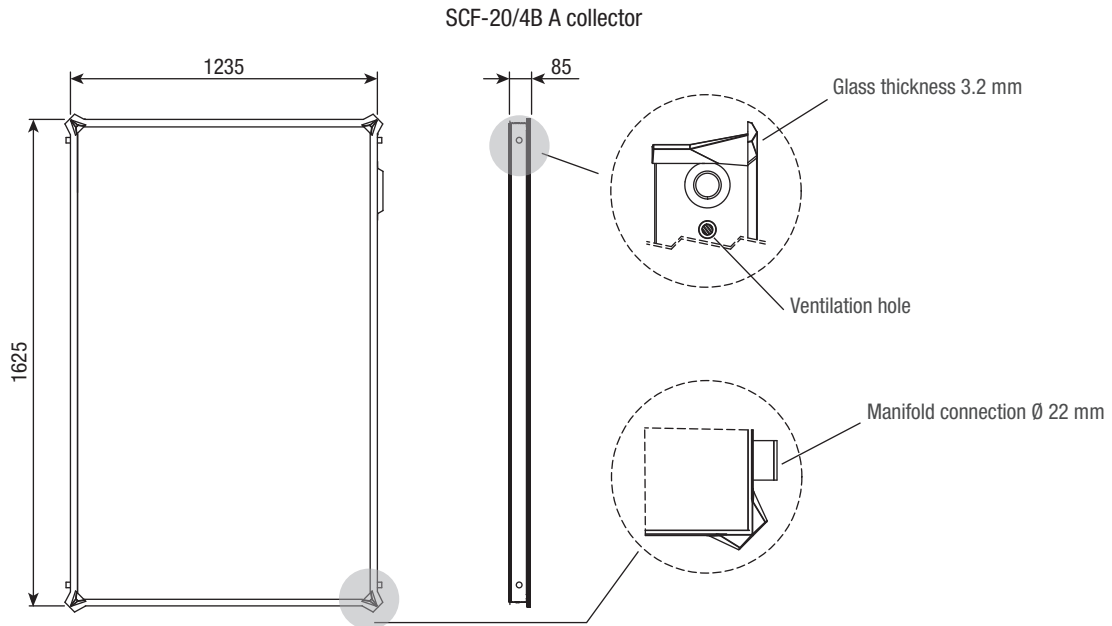

### SCF-20/4B A and SCF-25/4B A vertical flat solar collectors

## Positioning the sensors

The temperature sensor must be installed in the pocket located on the cap on the collector delivery pipe.  
 Only materials with suitable resistance to high temperatures (over 214°C for sensor element, contact paste, cables, gasket materials, insulation) may be used for sensor mounting.

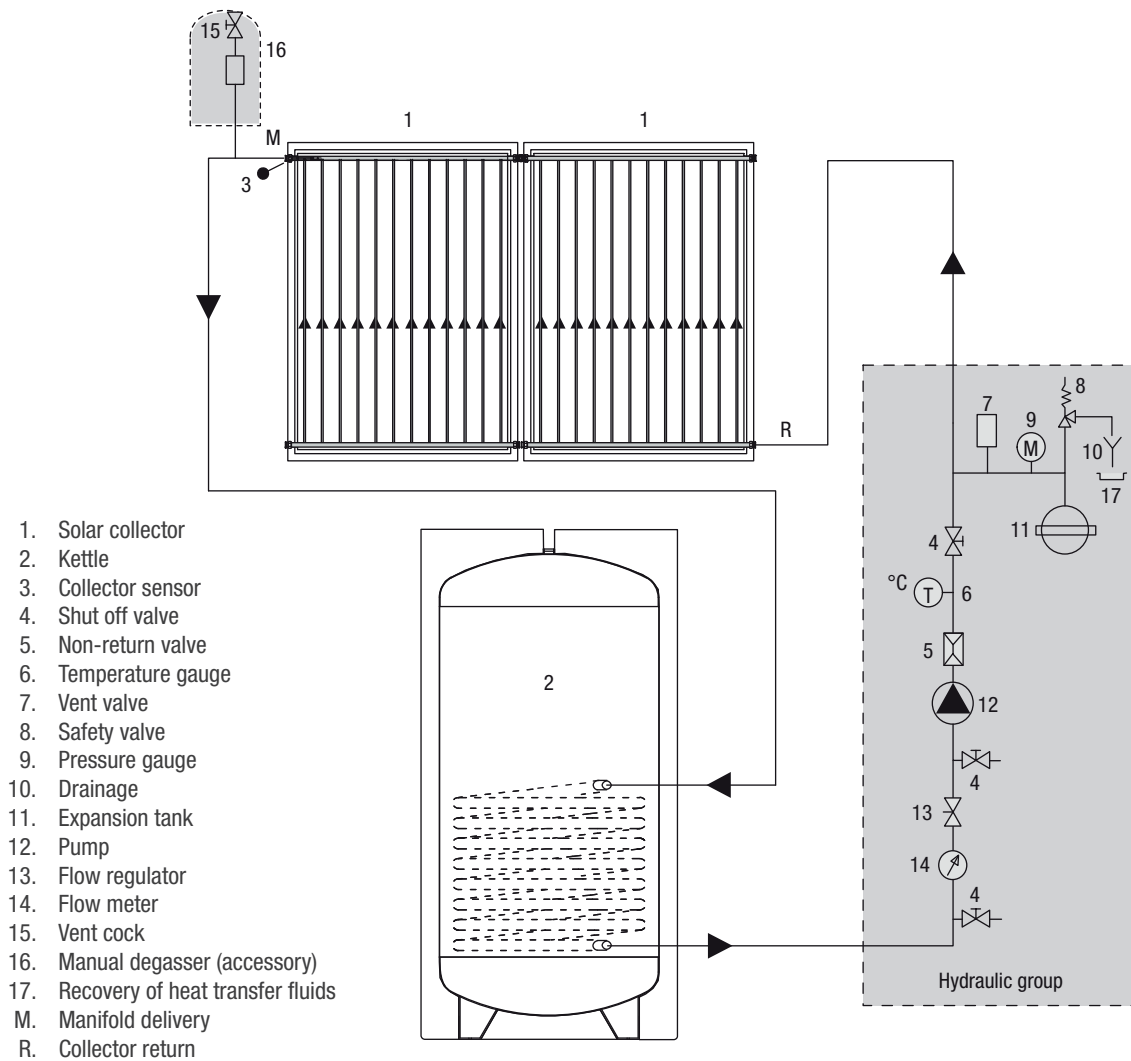

We recommend the use of stainless steel pipes specially made for solar collectors for the outlet, return and probe pipes.  
 Shielded cables are recommended for the electrical connection of the collector sensor.  
 If copper pipes are used, joints must be hot brazed.  
 The collector can reach temperatures up to 180°C: do not use plastic or multilayer pipes and ensure that suitable insulation is applied to the selected metal pipes.

**SCF-20/4B A and SCF-25/4B A vertical flat solar collectors**

# Installation

For checks of allowable loads contact a specialised technician.

In case of installations on flat roofs that cannot be drilled use ballasts (not supplied) fairly distributed on all the bearing points, as shown in the figure

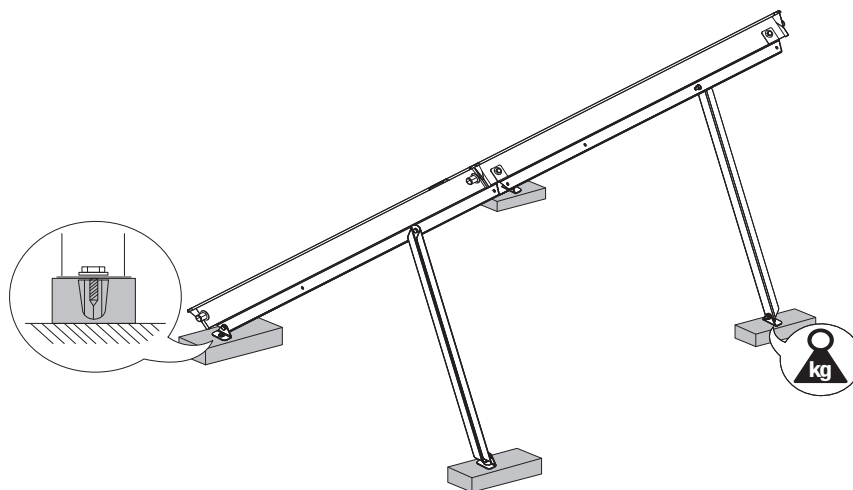

Wind speed km/h	Inclination angle of solar collectors	Mass in kg, distributed on the various bearing points, to secure a collector from wind lifting
100	30°-45°	135
130	30°-45°	255
150	30°-45°	355

# Precharge pressure diagram

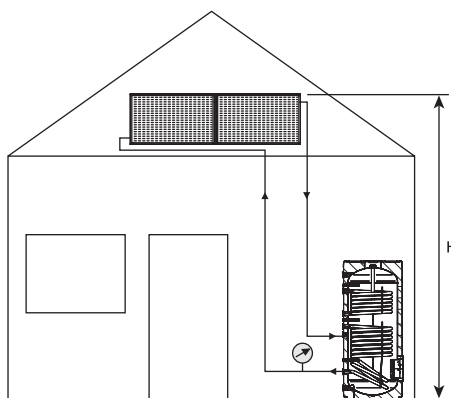

H	Precharge pressure
fino a 15 m	3 bar
15 - 20 m	3,5 bar
20 - 25 m	4 bar
25 - 30 m	4,5 bar

## SCF-20/4B A and SCF-25/4B A vertical flat solar collectors

# Hydraulic connections

During installation, pay attention to the position of the probe with respect to the collector.  
The collector probe must always be in the upper section of the panel as indicated in the figures below.

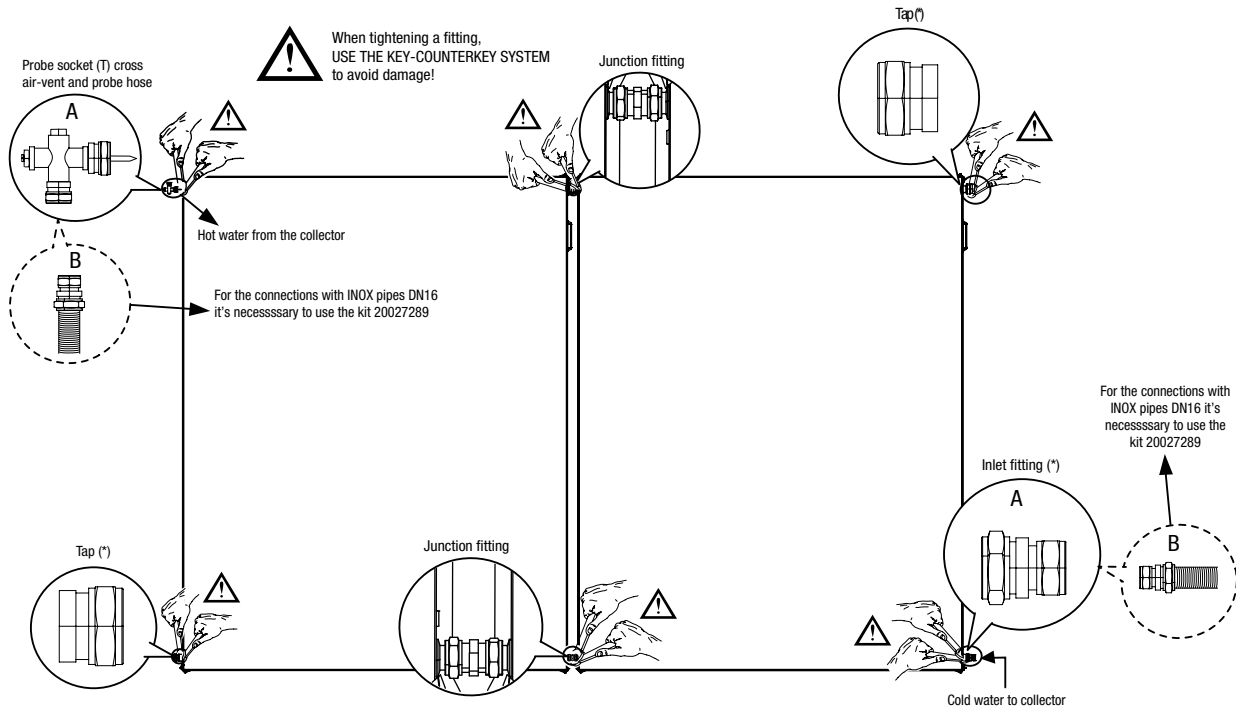

(\*) The connections can also be mirrored. The rule states that the probe holder connection is always located on the upper part of the collectors while the inlet connection is on the lower part.

**NB:** to connect the panel with a stainless steel pipe, an 18 mm section of copper pipe must be installed between fittings A (contained in code **20201448**) and B (contained in code **20027289**).

Collectors are connected with each other so that the heat transfer fluid crosses them in parallel.

Connection with the heat exchange circuit towards the exchanger must be made on the side of probe socket (T) of the last collector of the series (see Fig. 9).

The positioning of the socket on the collector allows the maximum transfer of heat accumulated in the panels.

It is also possible to connect more than one line of solar collectors, both in series (provided that the number of solar collectors does not exceed 10 units per each series) and in parallel. In any case the circuit must be hydraulically balanced as example diagrams below:

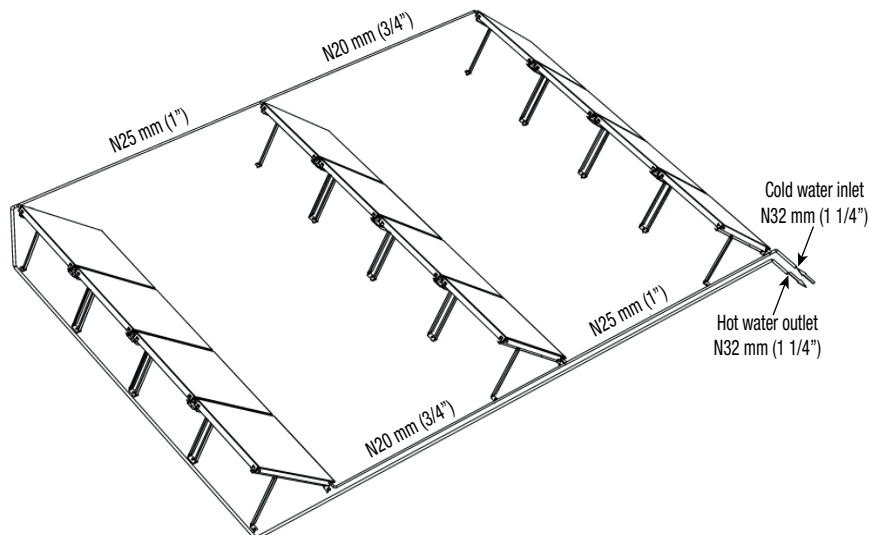

**SCF-20/4B A and SCF-25/4B A vertical flat solar collectors**

# Diameter of connecting pipes with a specific flow rate equal to 30 litres/m<sup>2</sup>h

Overall surface (m <sup>2</sup> )	2 - 4	6 - 12	14 - 20
Copper diameter (mm)	10 - 12	14	18
Steel diameter	3/8" - 1/2"	1/2"	3/4"

## Water + glycol pre-mixing

Glycol is supplied separately in standard packages and must be mixed with water in a container before filling the system (e.g. a 40% glycol + 60% water mixture allows frost resistance down to a temperature of -21 °C).

- The supplied propylene glycol is specially designed for solar applications as it retains its characteristics in the -32÷180 °C range. Furthermore, it is non-toxic, biodegradable and biocompatible.
- Do not introduce pure glycol into the system and subsequently add water.
- Do not use manual or automatic filling systems.
- In the case of very high chlorine content, use distilled water for the mixture.

Antifreeze	Temperature	Density
50%	-32 °C	1,045 kg/dm <sup>3</sup>
40%	-21 °C	1,037 kg/dm <sup>3</sup>
30%	-13 °C	1,029 kg/dm <sup>3</sup>

## Flat roof installation

The “flat roof bracket” accessory allows installing a panel with two different inclinations: 45° or 30°.

It consists of two support bars for the panel and two additional support bars for the bracket.

In case of installations involving multiple panels, the additional bracket kit can be added to the basic kit.

The approximate overall dimensions in relation to the number of connected panels are provided below.

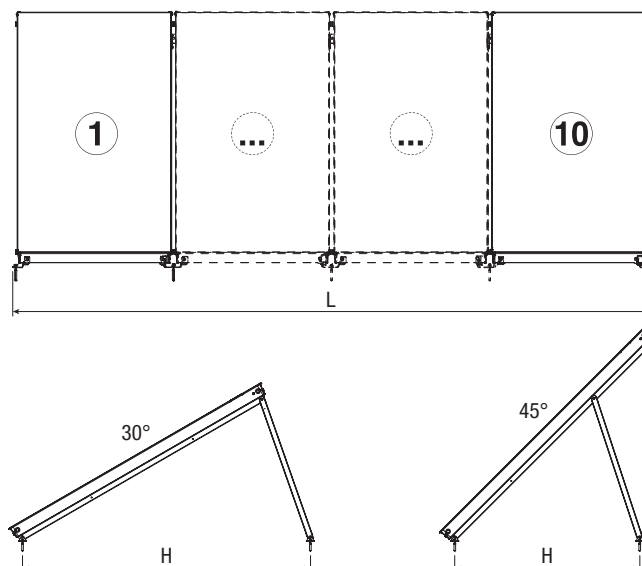

Number of collectors			1	2	3	4	5	6	7	8	9	10
SCF-20/4B A	L quote	m	1,27	2,54	3,81	5,08	6,35	7,62	8,89	10,16	11,43	12,70
	H 30° quote	m	1,62	1,62	1,62	1,62	1,62	1,62	1,62	1,62	1,62	1,62
	H 45° quote	m	1,05	1,05	1,05	1,05	1,05	1,05	1,05	1,05	1,05	1,05
SCF-25/4B A	L quote	m	1,27	2,54	3,81	5,08	6,35	7,62	8,89	10,16	11,43	12,70
	H 30° quote	m	2,00	2,00	2,00	2,00	2,00	2,00	2,00	2,00	2,00	2,00
	H 45° quote	m	1,29	1,29	1,29	1,29	1,29	1,29	1,29	1,29	1,29	1,29

## SCF-20/4B A and SCF-25/4B A vertical flat solar collectors

## Flat roof installation

Brackets kit for collectors 2 m<sup>2</sup> e 2,5 m<sup>2</sup>

in the tables below are shown the quantities and types of components to be ordered depending on the installation configuration chosen.

COLLECTORS 2 m <sup>2</sup>	BRACKETS1 COLL. 2mq "A" TP 30-45°	BRACKETS +1 COLL. 2mq "A" AGG. TP 30-45°	Hydraulic kit for 1 COLL "A"	Hydraulic kit for 2 COLL "A"	Hydraulic kit for 3 COLL "A"	Hydraulic kit for 4 COLL "A"	Hydraulic kit for 5 COLL "A"	Hydraulic kit for 6 COLL "A"	Hydraulic kit for 7 COLL "A"	Hydraulic kit for 8 COLL "A"	Hydraulic kit for 9 COLL "A"	Hydraulic kit for 10 COLL "A"
Kit for 1 COLL 2M2 TP 30-45°	1		1									
Kit for 2 COLL 2M2 TP 30-45°	1	1		1								
Kit for 3 COLL 2M2 TP 30-45°	1	2			1							
Kit for 4 COLL 2M2 TP 30-45°	1	3				1						
Kit for 5 COLL 2M2 TP 30-45°	1	4					1					
Kit for 6 COLL 2M2 TP 30-45°	1	5						1				
Kit for 7 COLL 2M2 TP 30-45°	1	6							1			
Kit for 8 COLL 2M2 TP 30-45°	1	7								1		
Kit for 9 COLL 2M2 TP 30-45°	1	8									1	
Kit for 10 COLL 2M2 TP 30-45°	1	9										1

COLLECTORS 2,5 m <sup>2</sup>	BRACKETS 1 COLL. 2,5mq "A" TP 30-45°	BRACKETS +1 COLL. 2,5mq "A" AGG. TP 30-45°	Hydraulic kit for 1 COLL "A"	Hydraulic kit for 2 COLL "A"	Hydraulic kit for 3 COLL "A"	Hydraulic kit for 4 COLL "A"	Hydraulic kit for 5 COLL "A"	Hydraulic kit for 6 COLL "A"	Hydraulic kit for 7 COLL "A"	Hydraulic kit for 8 COLL "A"	Hydraulic kit for 9 COLL "A"	Hydraulic kit for 10 COLL "A"
Kit for 1 COLL 2,5M2 TP 30-45°	1		1									
Kit for 2 COLL 2,5M2 TP 30-45°	1	1		1								
Kit for 3 COLL 2,5M2 TP 30-45°	1	2			1							
Kit for 4 COLL 2,5M2 TP 30-45°	1	3				1						
Kit for 5 COLL 2,5M2 TP 30-45°	1	4					1					
Kit for 6 COLL 2,5M2 TP 30-45°	1	5						1				
Kit for 7 COLL 2,5M2 TP 30-45°	1	6							1			
Kit for 8 COLL 2,5M2 TP 30-45°	1	7								1		
Kit for 9 COLL 2,5M2 TP 30-45°	1	8									1	
Kit for 10 COLL 2,5M2 TP 30-45°	1	9										1

NOTE: Make sure that the roof load-bearing structure can support the weight of the installed collectors.

### SCF-20/4B A and SCF-25/4B A vertical flat solar collectors

## Pitched roof installation

The “sloping roof bracket” accessory allows installing a panel on a sloping roof pitch and can be used for both 2 and 2.5 m<sup>2</sup> collectors. The type of installation consists of an under-tile coupling and of a joint element that allows linking the two panel supports and thus holding them in place when the panels are connected.

In case of installations involving multiple panels, the additional bracket kit can be added to the basic 2-collector bracket kit. The approximate overall dimensions in relation to the number of connected panels are provided below.

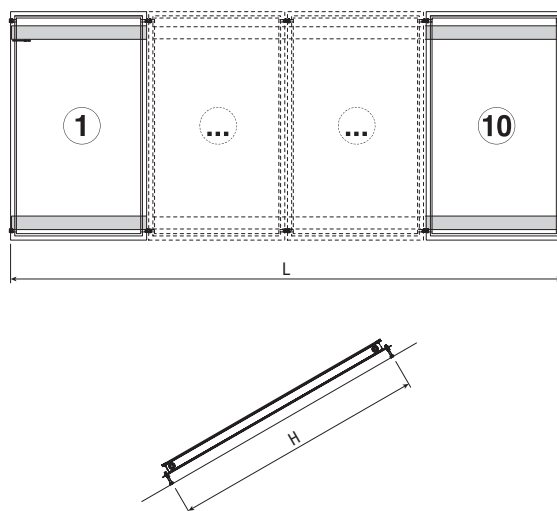

Number of collectors			1	2	3	4	5	6	7	8	9	10
SCF-20/4B A	L quote	m	1,27	2,54	3,81	5,08	6,35	7,62	8,89	10,16	11,43	12,70
	H quote	m	2,00	2,00	2,00	2,00	2,00	2,00	2,00	2,00	2,00	2,00
SCF-25/4B A	L quote	m	1,27	2,54	3,81	5,08	6,35	7,62	8,89	10,16	11,43	12,70
	H quote	m	2,40	2,40	2,40	2,40	2,40	2,40	2,40	2,40	2,40	2,40

## Pitched roof installation

### Common bracket kits for 2 m<sup>2</sup> and 2,5 m<sup>2</sup> collectors

In the tables below are shown the quantities and types of components to be ordered depending on the installation configuration chosen.

	BRACKETS 1 COLL. 2-2,5 "A" sotto tegola TI	BRACKETS 2 COLL. 2-2,5 "A" sotto tegola TI	BRACKETS +1 COLL. 2-2,5 "A" sotto tegola AGG. TI	kit 4 ganci x BRACKETS TI-Coll. "A"	kit 6 ganci x BRACKETS TI-Coll. "A"	Hydraulic kit for 1 COLL "A"	Hydraulic kit for 2 COLL "A"	Hydraulic kit for 3 COLL "A"	Hydraulic kit for 4 COLL "A"	Hydraulic kit for 5 COLL "A"	Hydraulic kit for 6 COLL "A"	Hydraulic kit for 7 COLL "A"	Hydraulic kit for 8 COLL "A"	Hydraulic kit for 9 COLL "A"	Hydraulic kit for 10 COLL "A"
Kit for 1 COLL 2-2,5M2 TI	1			1		1									
Kit for 2 COLL 2-2,5M2 TI		1			1		1								
Kit for 3 COLL 2-2,5M2 TI		1	1	1	1			1							
Kit for 4 COLL 2-2,5M2 TI		1	2	2	1				1						
Kit for 5 COLL 2-2,5M2 TI		1	3	3	1					1					
Kit for 6 COLL 2-2,5M2 TI		1	4	4	1						1				
Kit for 7 COLL 2-2,5M2 TI		1	5	5	1							1			
Kit for 8 COLL 2-2,5M2 TI		1	6	6	1								1		
Kit for 9 COLL 2-2,5M2 TI		1	7	7	1									1	
Kit for 10 COLL 2-2,5M2 TI		1	8	8	1										1

NOTE: Make sure that the roof load-bearing structure can support the weight of the installed collectors.

## SCF-20/4B A and SCF-25/4B A vertical flat solar collectors

# Specification Guide

## SCF-20/4B A Solar Collector

The SCF-20/4B A solar collector, which is only suitable for vertical installation, consists of:

- 2.0 m<sup>2</sup> gross area.
- 1.90 m<sup>2</sup> actual absorber area
- Absorber consisting of an aluminium capture plate with selective TiNOx Energy Al finish.
- 95% energy absorption.
- 4% emissivity.
- Internal pipe circuit consisting of 2 horizontal copper ND22 manifolds to which the harp, consisting of 12 parallel ND8 pipes and also made of copper, is laser-welded. Ultrasonic welding allows obtaining a high yield of the solar collector; the copper harp is slightly bent in way of the ND22 manifolds to maximise the actual exchange surface between the absorber and the ND8 pipes containing the heat transfer fluid.
- 4 ND22 mm copper couplings with compression fittings.
- Up to 10 collectors can be connected in series vertically.
- Frame made of high-quality galvanised steel, 0.42 mm thick, pre-painted for maximum resistance to corrosion and aggressive/marine environments.
- 30 mm rock wool insulation, density 40 kg/m<sup>3</sup>, allowing high performance even at low temperatures.
- Clear tempered prismatic glass with low iron content. It is of the “mistlite” type, so it has a rough visual appearance. It is 3.2 mm thick and is fastened to the frame by means of a polymeric material called Colofast®. Colofast® provides a perfect joint between glass and frame, providing strength as well as flexibility. Moreover, this type of joint makes the panel perfectly weatherproof and gives it a neat finish.

## SCF-25/4B A Solar Collector

The SCF-25/4B A solar collector, which is only suitable for vertical installation, consists of:

- 2.49 m<sup>2</sup> gross area.
- 2.37 m<sup>2</sup> actual absorber area
- Absorber consisting of an aluminium capture plate with selective TiNOx Energy Al finish.
- 95% energy absorption.
- 4% emissivity.
- Internal pipe circuit consisting of 2 horizontal copper ND22 manifolds to which the harp, consisting of 12 parallel ND8 pipes and also made of copper, is laser-welded. Ultrasonic welding allows obtaining a high yield of the solar collector; the copper harp is slightly bent in way of the ND22 manifolds to maximise the actual exchange surface between the absorber and the ND8 pipes containing the heat transfer fluid.
- 4 ND22 mm copper couplings with compression fittings.
- Up to 10 collectors can be connected in series vertically.
- Frame made of high-quality galvanised steel, 0.42 mm thick, pre-painted for maximum resistance to corrosion and aggressive/marine environments.
- 30 mm rock wool insulation, density 40 kg/m<sup>3</sup>, allowing high performance even at low temperatures.
- Clear tempered prismatic glass with low iron content. It is of the “mistlite” type, so it has a rough visual appearance. It is 3.2 mm thick and is fastened to the frame by means of a polymeric material called Colofast®. Colofast® provides a perfect joint between glass and frame, providing strength as well as flexibility. Moreover, this type of joint makes the panel perfectly weatherproof and gives it a neat finish.

## Features common to both collectors

- Stagnation temperature equal to 180°C.
- Maximum operating pressure 10 bar.
- Compliant with the EN 12975-1 and ISO 9806 standards.
- Solar Keymark certification.
- 5-year warranty.

# NB-SOL-A 160/2,5 - 200/2,5 - 200/4 - 300/4 - 300/5 natural circulation solar systems

## Product description

Our system NB-SOL-A is a solar hot water heating system that functions on the principle of natural circulation. The heat transfer liquid therefore circulates by normal convection.

The system comprises one or more solar collectors and a jacket type storage tank, located above the collector/s.

The system does not require any pumps or adjustments and comprises:

- Solar collector/s.
- A jacket type solar storage tank.
- Carton box with: fittings, anti-freeze liquid, 1 installation manual and 1 manual with the images for the installation.
- Mounting brackets.
- Water pipes.

The system is equipped with the following safety devices:

- A primary circuit safety valve that opens if pressure in the primary (solar collector) circuit rises above a 2,5 bar threshold.
- A secondary circuit safety valve that opens if pressure in the secondary (DHW) circuit rises above a 10 bar threshold.



## Technical data

System		160/2,5	200/2,5	200/4	300/4	300/5
<b>Dimensions</b>						
Flat roof 45 °	L	1314	1526	2586	2586	2586
	P	1903	1903	1626	1626	1903
	H	2006	2006	1727	1727	2006
Inclined roof 0°	L	1314	1526	2586	2586	2586
	P	2657	2657	2197	2197	2657
	H	825	825	825	825	825
Weight of the empty system (*)	kg	93,4	108,4	131,3	154,3	166,8
Full system weight (*)	kg	245,9	299,9	324,1	433,1	445,9
Qnonsol M (**)	kWh	410	410	279	270	218
Qnonsol L (**)	kWh	1231	1187	863	802	679
Qnonsol XL (**)	kWh	2579	2500	1930	1790	1536
Qnonsol XXL (**)	kWh	3716	3629	2937	2729	2376
<b>Storage tank</b>						
Storage tank volume	l	151	190	190	276	276
Empty storage tank weight	kg	58	73	73	96	96
Full storage tank weight	kg	209	263	263	372	372
Length	mm	1230	1526	1526	2150	2150
Diameter	Ø mm	500	500	500	500	500
Electric heater	kW	1,5	1,5	1,5	1,5	1,5
Magnesium anode	Ø x mm	22×500	26×450	26×450	26×450	26×450
Max pressure DHW circuit	bar	10	10	10	10	10
Max pressure solar circuit	bar	2,5	2,5	2,5	2,5	2,5

**NB-SOL-A 160/2,5 - 200/2,5 - 200/4 - 300/4 - 300/5 natural circulation solar systems**

System		160/2,5	200/2,5	200/4	300/4	300/5
<b>Collectors</b>						
Type		2,5	2,5	2	2	2,5
Dimensions	mm	1235×2020×85	1235×2020×85	1235×1625×85	1235×1625×85	1235×2020×85
Number of collectors		1	1	2	2	2
Gross area per collector	m <sup>2</sup>	2,5	2,5	2	2	2,5
Opening area for the collector	m <sup>2</sup>	2,39	2,39	1,91	1,91	2,39
Area of the absorber for the collector	m <sup>2</sup>	2,37	2,37	1,9	1,9	2,37
Weight per empty collector	kg	35,4	35,4	29,15	29,15	35,4
Maximum working temperature	°C	180	180	180	180	180
Thermal liquid for absorber	l	1,55	1,55	1,38	1,38	1,55

(\*) Storage tank + collector/s. The brackets are not included.

(\*\*) Value calculated in terms of primary energy for electricity and/or in terms of calorific value for fuel, in average climatic conditions, in load profiles M,L,XL, XXL, with permanent backup and boiler.

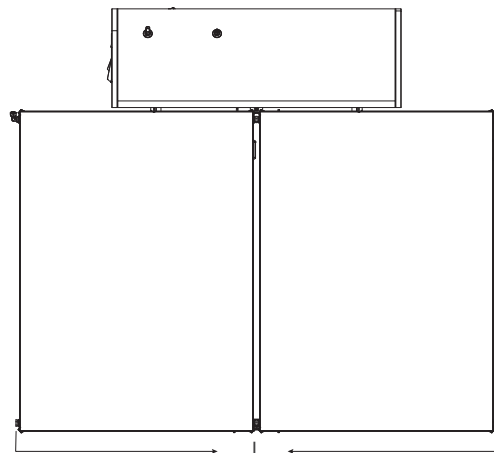
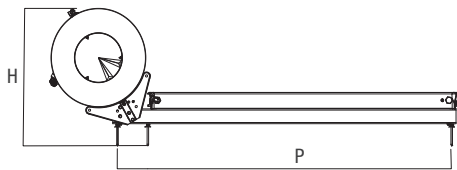

NB-SOL-A 160/2,5 - 200/2,5 - 200/4 - 300/4 - 300/5 natural circulation solar systems

# Head losses of solar collectors

Single solar collector head losses (33,3% glycol) - 2,0 m<sup>2</sup>

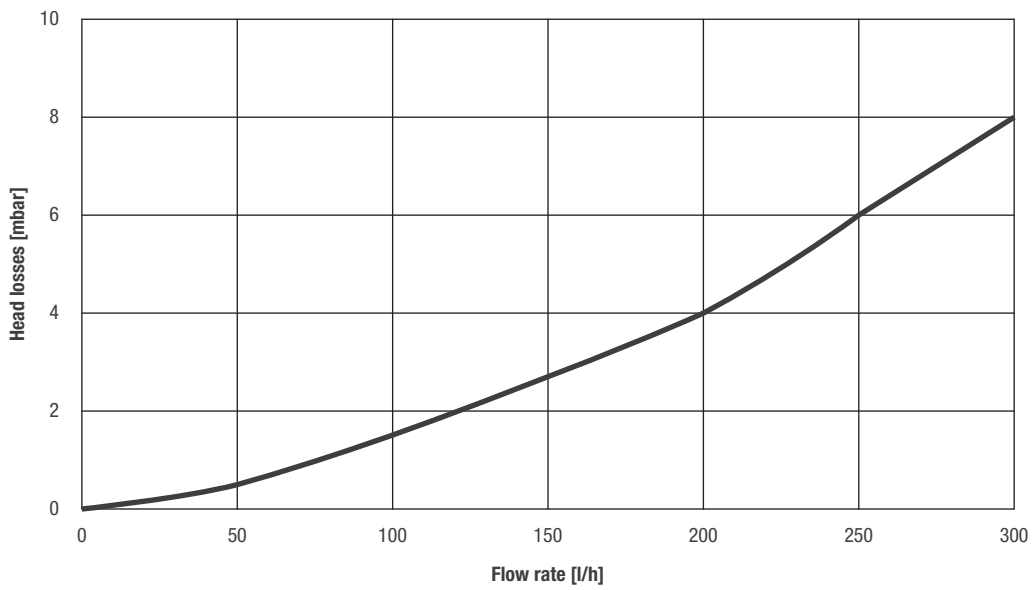

Single solar collector head losses (33,3% glycol) - 2,5 m<sup>2</sup>

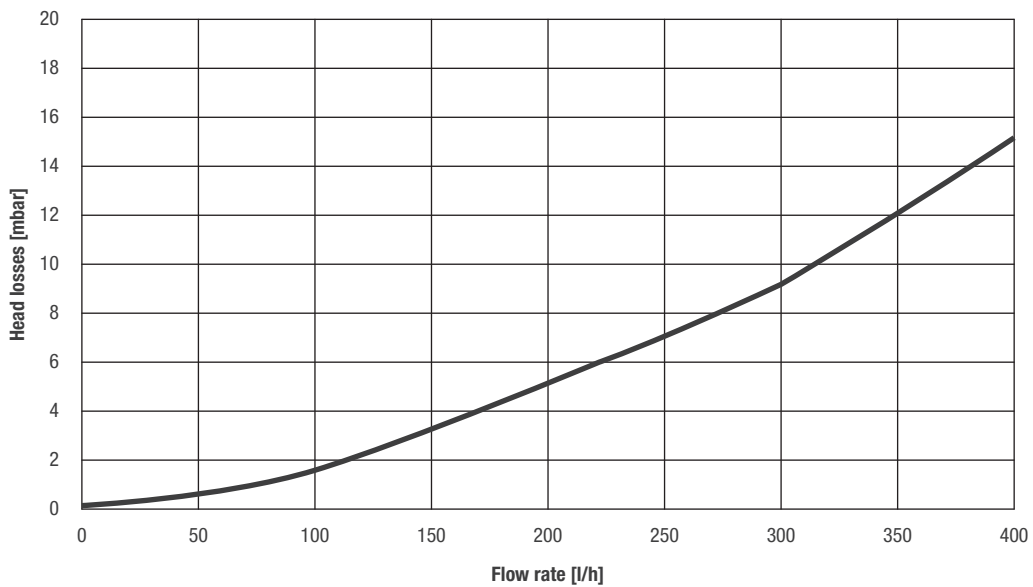

NB-SOL-A 160/2,5 - 200/2,5 - 200/4 - 300/4 - 300/5 natural circulation solar systems

# Efficiency curve

Efficiency curve - solar collector 2,0 m<sup>2</sup>

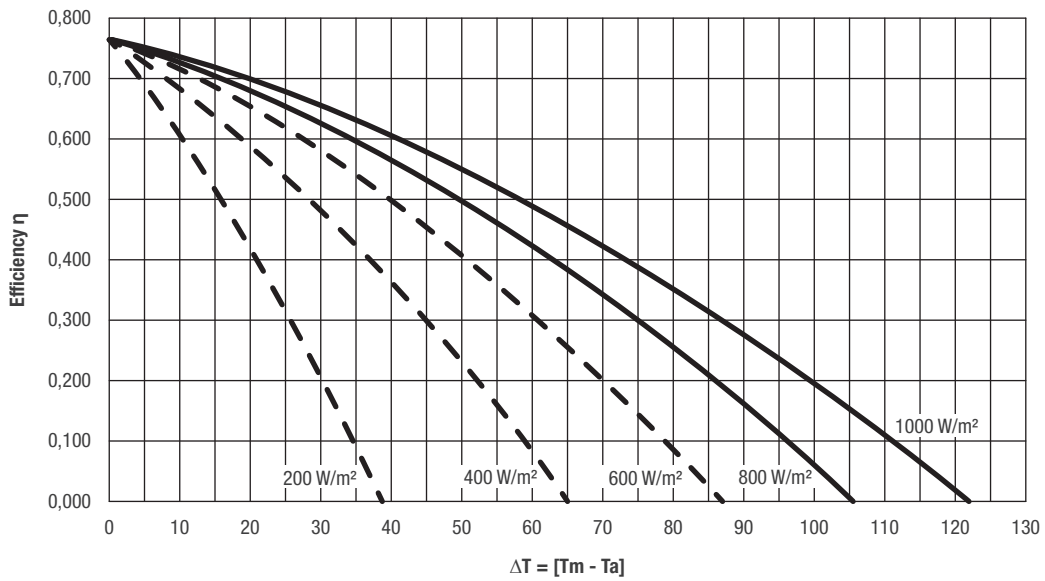

Efficiency curve - solar collector 2,5 m<sup>2</sup>

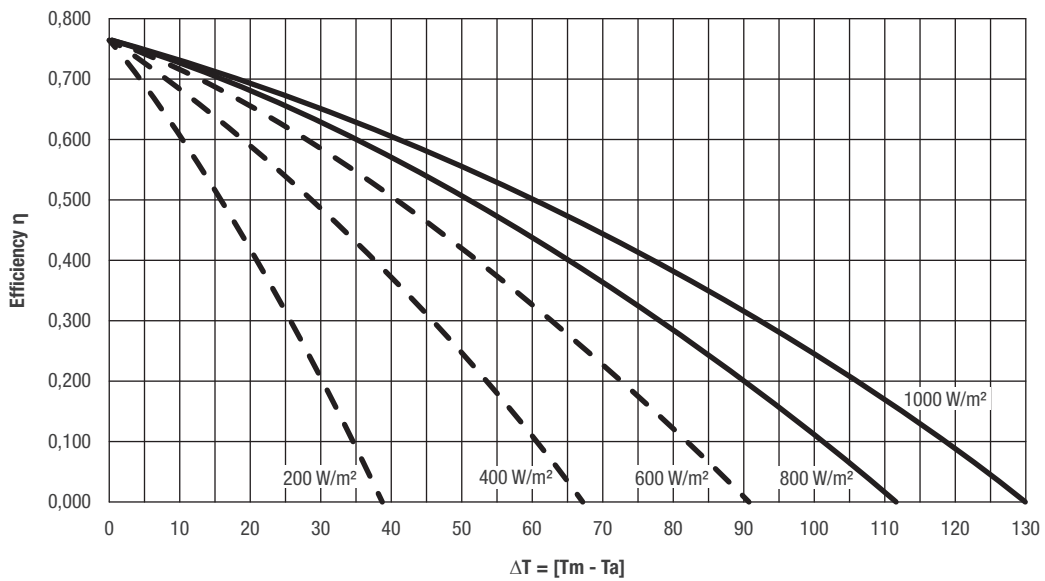

T<sub>m</sub> = Average temperature of solar collector  
 T<sub>a</sub> = Outdoor temperature

NB-SOL-A 160/2,5 - 200/2,5 - 200/4 - 300/4 - 300/5 natural circulation solar systems

# Output power curve

Returned power curve - solar collector 2,0 m<sup>2</sup>

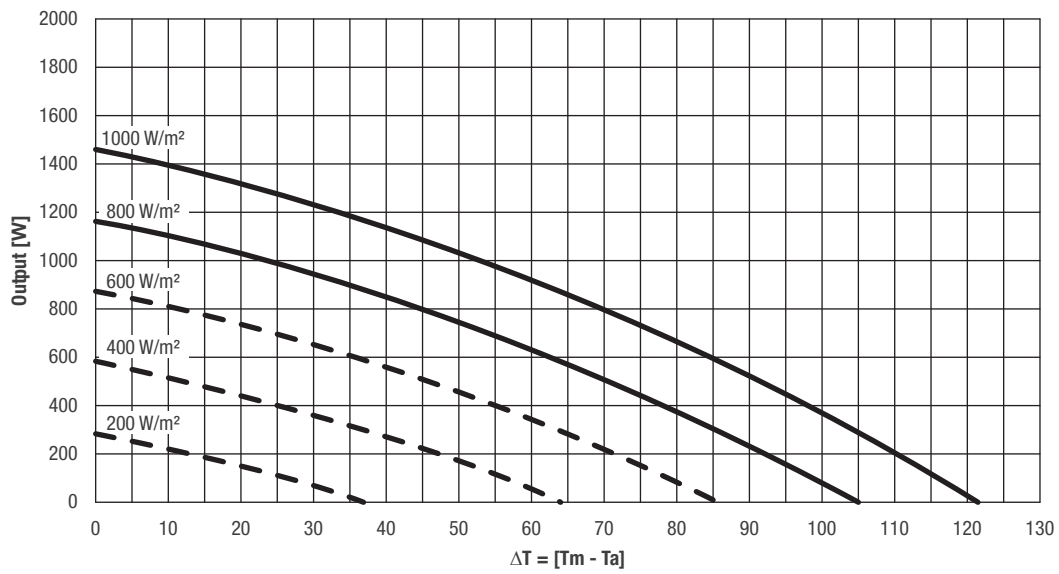

Returned power curve - solar collector 2,5 m<sup>2</sup>

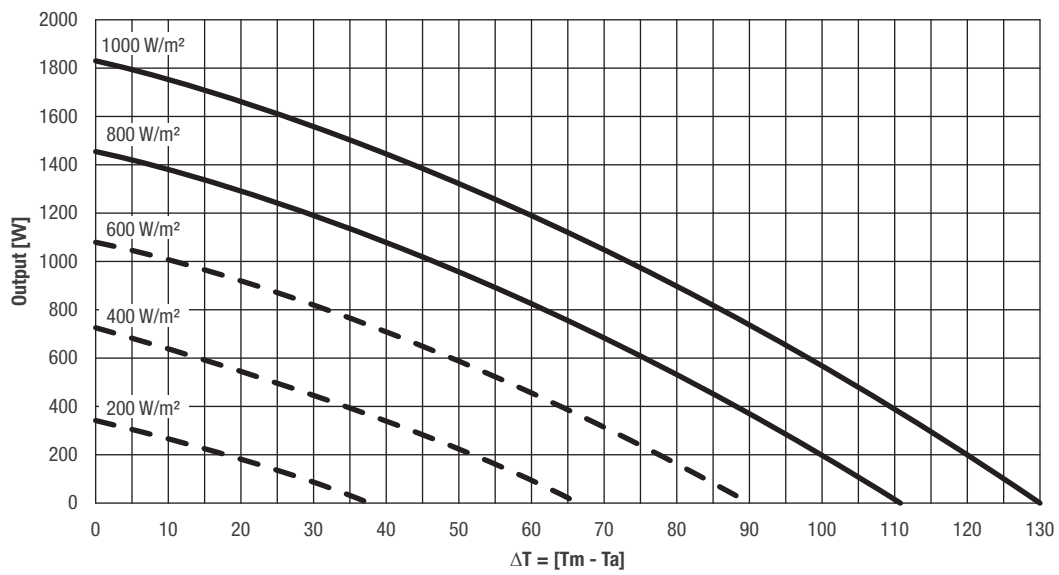

T<sub>m</sub> = Average temperature of solar collector  
 T<sub>a</sub> = Outdoor temperature

NB-SOL-A 160/2,5 - 200/2,5 - 200/4 - 300/4 - 300/5 natural circulation solar systems

# Structure

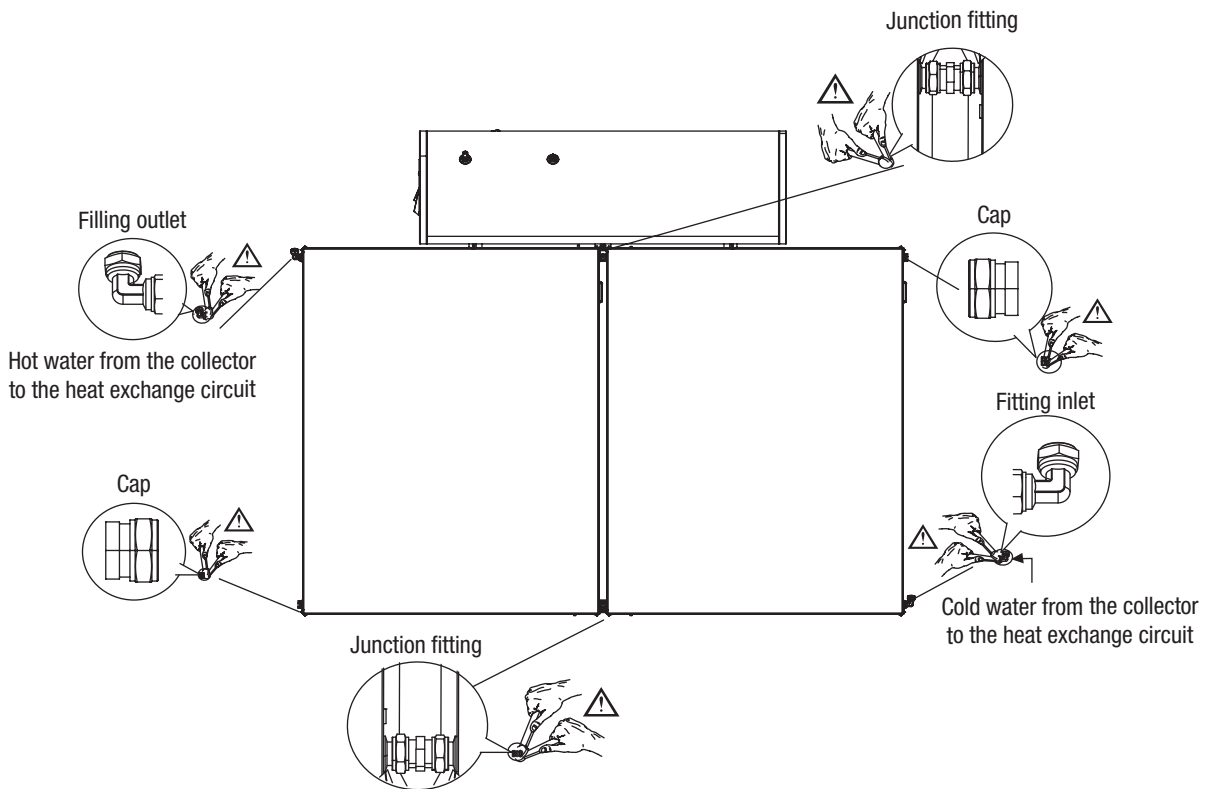
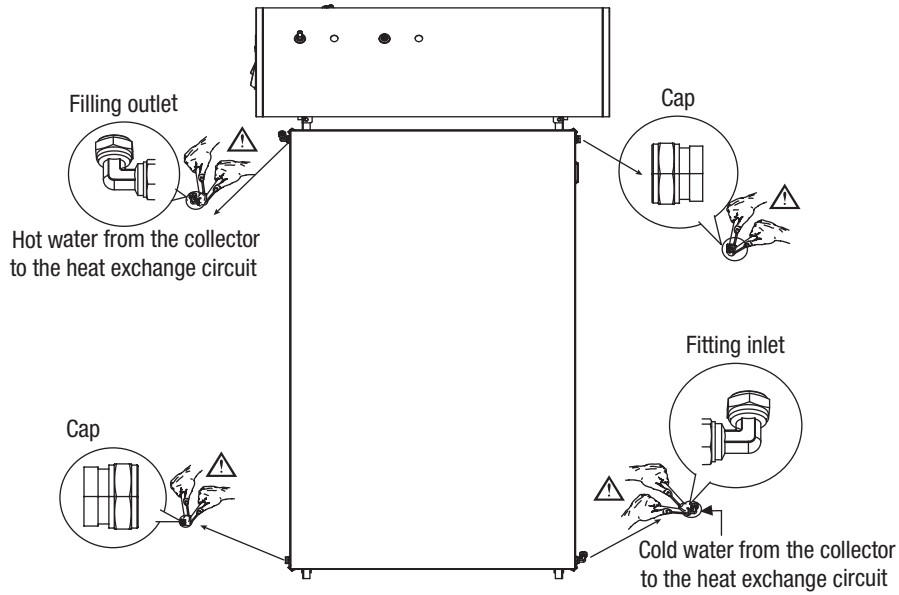

**NB-SOL-A 160/2,5 - 200/2,5 - 200/4 - 300/4 - 300/5 natural circulation solar systems**

## Preparing for installation

1. Select the best possible orientation for the solar collectors (ideally facing south).
2. Avoid positions that are shaded by plants, trees, buildings or hills, etc. during the day..
3. Maintain the minimum distance (A) between the system and the edge of the roof.
4. Remove all gravel and detritus from the surface on which the system is to be installed.
5. The mounting kit must not be used to install other superstructures. It is designed only for use with our solar water heating systems.
6. The installation of a solar water heating system modifies the existing structure of the roof. Verify the suitability of all roof elements and if necessary adapt them to avoid leaks or damage by wind and/or snow loads.

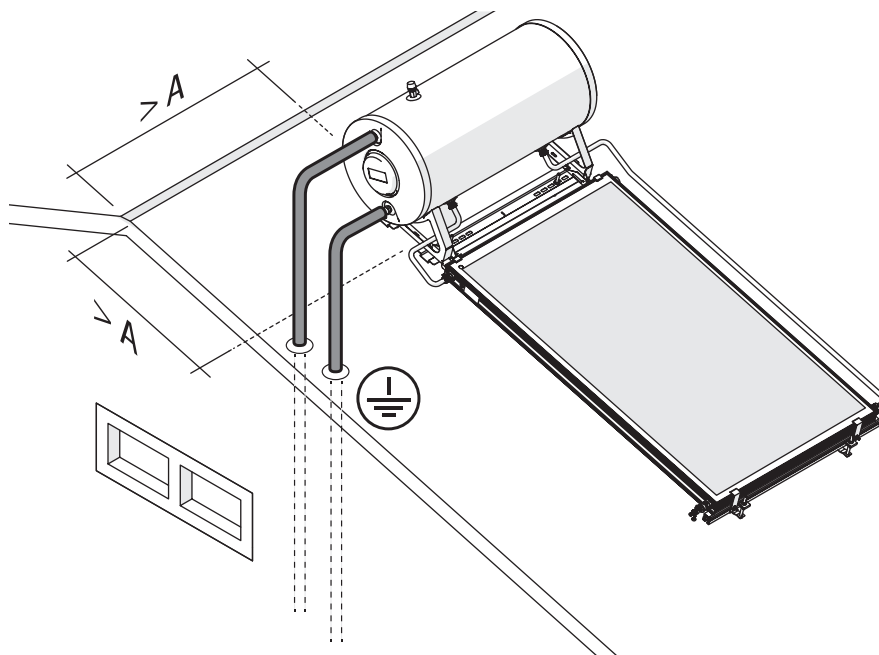

U.M.		Natural circulation system				
		160/2,5	200/2,5	200/4	300/4	300/5
A	m	1	1	1,5	1,5	1

## Electrical connections

All storage tanks are supplied with a thermostat pre set at 80°C. Before starting, set the thermostat to the desired temperature.

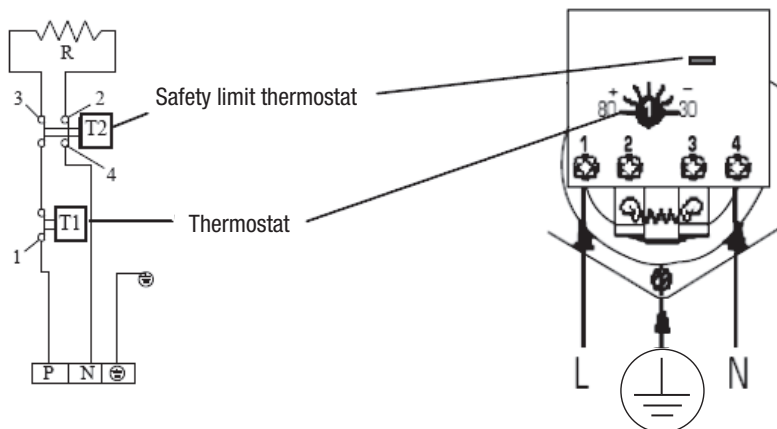

**NB-SOL-A 160/2,5 - 200/2,5 - 200/4 - 300/4 - 300/5 natural circulation solar systems**

## System water connection

The water supply circuit must permit the storage cylinder to be filled and emptied in safety. Shut-off valves must therefore be easily accessible to the user and the operation of emptying the storage cylinder must not create any risk of flooding or other damage.

- All water pipe connections must conform to applicable standards.
- The operating pressure limits specified on the data plate must never be exceeded. It may therefore be necessary to fit a pressure reducer.
- A thermal mixing valve must always be connected to the hot water outlet to control the temperature of hot water at the taps.
- The point through which the water pipes enter the building must be rain-proof and damp-proof.

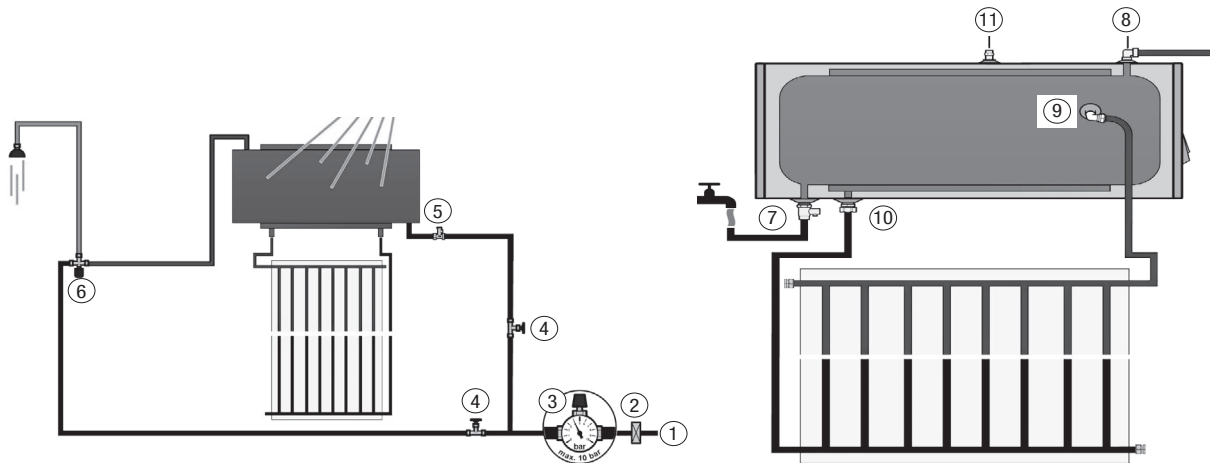

### Complete scheme of the system

1. Domestic cold water inlet.
2. Water filter.
3. Pressure reducer MAX 10 bar.
4. Shut-off valve.
5. Non-return valve + safety valve 10 bar.
6. Thermostatic DHW mixer.

### Natural circulation system diagram

7. Domestic cold water supply, safety valve safety valve 10bar + non-return valve.
8. Domestic hot water outlet.
9. Solar circuit, hot glycol inlet.
10. Solar circuit, cold glycol outlet.
11. Safety valve 2.5 bar.

## Filling circuit of the solar collector

### Heat transfer fluid

The antifreeze provided with NB-SOL-A contains non-toxic, biodegradable and ecological propylene glycol.

Mix propylene glycol with water (preferably de-mineralized). Determine the required concentration of propylene glycol using the table opposite based on the temperatures for which frost protection is required.

- To top up the circuit, use only the products listed in our catalogue..

Antifreeze liquid	Temperature	Density (20°C)
55%	-40 °C	1.048 kg/dm <sup>3</sup>
50%	-32 °C	1.045 kg/dm <sup>3</sup>
45%	-26 °C	1.042 kg/dm <sup>3</sup>
40%	-21 °C	1.037 kg/dm <sup>3</sup>
35%	-17 °C	1.033 kg/dm <sup>3</sup>
30%	-14 °C	1.029 kg/dm <sup>3</sup>
25%	-10 °C	1.023 kg/dm <sup>3</sup>

## NB-SOL-A 160/2,5 - 200/2,5 - 200/4 - 300/4 - 300/5 natural circulation solar systems

# Specification Guide

## Solar collector 2,0 m<sup>2</sup>

### Features:

- Gross surface area from 2,0 m<sup>2</sup>.
- Effective absorber surface area of 1,90 m<sup>2</sup>.
- Absorber consisting of an aluminium absorber plate with selective TiNOx Energy AI finish.
- Energy absorption 95%.
- Emissivity 4%.
- Internal hydraulic circuit consisting of 2 horizontal copper DN22 manifolds to which the harp, also made of copper, consisting of 12 parallel DN8 pipes is laser-welded. The ultrasonic welding results in a high yield of the solar collector; the copper harp is slightly bent at the DN22 collectors to maximise the effective exchange surface between absorber and DN8 pipes, containing the heat transfer fluid.
- 4 copper DN 22 mm connections with compression fittings.
- Frame made of high-quality galvanised steel, 0,42 mm thick, pre-painted for maximum resistance to corrosion and aggressive/marine environments.
- Insulation made of 30 mm rock wool, density 40 kg/m<sup>3</sup>, allowing high performance even at low temperatures.
- Clear tempered prismatic glass with low iron content. It is of the 'mistlite' type, thus presenting a rough appearance to the eye. It is 3,2 mm thick and is fixed to the frame by a polymeric material called Colofast®. Colofast® provides a perfect joint between the glass and the frame, ensuring robustness but at the same time flexibility. In addition, this type of joint makes the panel perfectly weatherproof and gives it a perfect finish.

## Solar collector 2,5 m<sup>2</sup>

### Features:

- Gross surface area of 2,49 m<sup>2</sup>.
- Effective absorber surface area of 2,37 m<sup>2</sup>.
- Absorber consisting of an aluminium absorber plate with selective TiNOx Energy AI finish.
- Energy absorption 95%.
- Emissivity 4%.
- Internal hydraulic circuit consisting of 2 horizontal copper DN22 manifolds to which the harp, also made of copper, consisting of 12 parallel DN8 pipes is laser-welded. The ultrasonic welding results in a high yield of the solar collector; the copper harp is slightly bent at the DN22 collectors to maximise the effective exchange surface between absorber and DN8 pipes, containing the heat transfer fluid.
- 4 copper DN 22 mm connections with compression fittings.
- Frame made of high-quality galvanised steel, 0,42 mm thick, pre-painted for maximum resistance to corrosion and aggressive/marine environments.
- 30 mm rock wool insulation, density 40 kg/m<sup>3</sup>, allowing high performance even at low temperatures.
- Clear tempered prismatic glass with low iron content. It is of the 'mistlite' type, thus presenting a rough appearance to the eye. It is 3,2 mm thick and is fixed to the frame by a polymeric material called Colofast®. Colofast® provides a perfect joint between the glass and the frame, ensuring strength but at the same time flexibility. In addition, this type of joint makes the panel perfectly weatherproof and gives it a perfect finish.

## Features common to both collectors

- Stagnation temperature 180°C.
- Maximum working pressure 10 bar.
- Complies with EN 12975-1 and ISO 9806 standards.
- Solar Keymark certified.
- 5-year warranty.

## Cylinder

- Capacity 151 - 190 - 276 litres.
- Enamelled steel.
- Length 1230 mm (mod. 160), 1526 mm (mod. 200), 2150 mm (mod.300).
- Diameter 500 mm.
- Electric heater 1,5 kW.
- Magnesium anode.
- Max sanitary circuit pressure 10 bar.
- Max solar circuit pressure 2,5 bar.
- Complies with standard UNI EN 12897.

## Double-coil cylinders

### IDRA DS 200-300-430-550-750-1000



**vertical storage cylinder in glazed steel with double-coil heat exchanger**

**ideal for solar systems**

**durability and hygiene guaranteed by glazing**

**anodic corrosion protection**

**high performance in hot water production and short recovery times**

**effective thermal insulation and low pressure drop**

**large heat exchange surface area of the lower coil**

**5-year warranty**

Beretta double coil solar cylinder from 200 to 1000 litres can be integrated in solar systems for the production of domestic hot water. The main technical elements in the design of the solar cylinder are:

- The accurate study of tank and coil geometries that allow to obtain the best performance in terms of stratification, heat exchange and recovery times.
- The internal glazing, bacteriologically inert, that ensures maximum hygiene of the treated water, reduces the possibility of limescale build-up and facilitates cleaning.
- The arrangement of the connections at different heights to use different types of heat generators, without affecting the stratification.
- CFC-free polyurethane insulation and an elegant outer housing to limit heat loss and therefore increase performance.
- The use of the flange to facilitate cleaning and maintenance and the magnesium anode with "anti-corrosion" function.

Predisposition for accessories:

- Differential control SUN B or Evosol.
- Hydraulic return or delivery/return kit.
- Solar expansion vessel of 18-24-35-50 litres.

## Double-coil cylinders IDRA DS 200-300-430-550-750-1000

# Technical data sheet

Description	Unit	IDRA DS 200	IDRA DS 300	IDRA DS 430	IDRA DS 550	IDRA DS 750	IDRA DS 1000
Cylinder type		Vertical, Glazed					
Exchanger layout		Vertical with elliptical section					
Cylinder capacity	l	208	301	442	551	731	883
Non-solar usable volume (Vbu)*	l	68	117	182	175	251	312
Solar usable volume (Vsol)**	l	140	184	260	376	480	570
Diameter of cylinder with insulation	mm	604	604	755	755	1000	1000
Diameter of cylinder with no insulation	mm	-	-	-	-	790	790
Height with insulation	mm	1338	1838	1644	1988	1846	2171
Height without insulation	mm	-	-	-	-	1745	2070
Insulation thickness	mm	50	50	50	50	100	100
Total net weight	kg	86	108	131	171	222	245
Diameter/length of magnesium anode	mm	33/450	33/450	33/520	33/520	40/600	40/600
Inside flange diameter	mm	130	130	130	130	130	130
Diameter/length of sensor-holder pockets	mm	18/180	18/180	18/180	18/180	16/180	16/180
Upper coil water content	l	3.4	4.5	6.0	6.0	9.1	9.1
Upper coil exchange surface	m <sup>2</sup>	0.7	0.8	1.0	1.0	1.6	1.6
Lower coil water content	l	3.4	5.1	7.5	9.0	11.8	12.3
Lower coil exchange surface	m <sup>2</sup>	0.7	1.0	1.4	1.8	2.3	2.7
Maximum cylinder operating pressure	bar	10	10	10	10	7	7
Maximum coil operating pressure	bar	10	10	10	10	7	7
Maximum operating temperature	°C	99	99	99	99	99	99
Dissipation according to EN 12897:2006 $\Delta T=45^{\circ}\text{C}$ (ambient temperature 20 °C and storage at 65 °C)	W	62	69	60	68	94	101
Heat loss according to UNI 11300	W/K	1.38	1.53	1.33	1.51	2.09	2.24
Energy class		B	B	B	B	B	B

\* Vbu - The non-solar useful volume expresses the amount of water (in litres) heated directly by the thermal integration coil. It is calculated as the volume between the upper part of the cylinder and the lower part of the thermal integration element (lower turn of the integration coil).

\*\* Vsol - The usable solar volume indicates the quantity of water (in litres) heated directly by the solar coil (placed in the lower part of the cylinder) minus the non-solar volume (Vbu).

## Performance referred to the integration coil

Upper coil continuous output (DHW 10-45 °C) (reference volume Vbu).

Coil delivery temperature		Unit	IDRA DS 200	IDRA DS 300	IDRA DS 430	IDRA DS 550	IDRA DS 750	IDRA DS 1000
80 °C	$\Delta T$ 20K	kW	16.1	23	31.4	31.4	50	50
		l/h	400	572	774	774	1240	1240
70 °C	$\Delta T$ 20K	kW	10.3	17	20.7	20.7	38	38
		l/h	247	425	505	505	930	930
60 °C	$\Delta T$ 20K	kW	6.5	11	15.5	15.5	25	25
		l/h	160	277	375	375	620	620
50 °C	$\Delta T$ 20K	kW	2.4	5	7	7	15	15
		l/h	57	130	170	170	380	380

Set-up time required to heat the cylinder to 60 °C, referred to the integration coil sensor, at various upper coil inlet temperatures with a coil inlet/outlet delta ( $\Delta$ ) of 20 °C (reference volume Vbu).

Upper coil delivery temperature		Unit	IDRA DS 200	IDRA DS 300	IDRA DS 430	IDRA DS 550	IDRA DS 750	IDRA DS 1000
80 °C	$\Delta T$ 20K	min	25	27	24	24	26	28
70 °C	$\Delta T$ 20K	min	33	34	32	32	34	40
60 °C	$\Delta T$ 20K	min	66	65	65	65	65	67

Thermal output coefficient NL according to DIN 4708. The NL index, referred to the integration exchanger, indicates a number of apartments having 3.5 people that can be fully supplied, with a 140 litres and two other drawing points.

Upper coil delivery temperature		IDRA DS 200	IDRA DS 300	IDRA DS 430	IDRA DS 550	IDRA DS 750	IDRA DS 1000
80 °C		1.12	1.64	2.2	2.23	3.63	3.79
70 °C		0.86	1.34	1.66	1.69	2.88	3.19
60 °C		0.65	1.04	1.37	1.42	2.17	2.47

## Double-coil cylinders IDRA DS 200-300-430-550-750-1000

### Emptying in 10'

#### Performance referred to the integration coil

Quantity of domestic water obtained in 10' with cylinder pre-heated to 60°C (\*) and primary exchanger at the indicated delivery temperature, considering an increase of the domestic water temperature of 30°C between inlet and outlet (according to EN 12897).

Upper coil delivery temperature	Unit	IDRA DS 200	IDRA DS 300	IDRA DS 430	IDRA DS 550	IDRA DS 750	IDRA DS 1000
80°C	l	166	260	330	345	595	673
70°C	l	138	255	323	340	513	666
60°C	l	131	250	308	336	473	626

\* Integration coil sensor point reference, Vbu reference volume.

#### Performance referred to the solar coil

Quantity of domestic water obtained in 10' with cylinder pre-heated to the indicated temperature (\*) considering an increase of the domestic water temperature of 30°C between inlet and outlet (according to EN 12897).

Storage bottom temperature	Unit	IDRA DS 200	IDRA DS 300	IDRA DS 430	IDRA DS 550	IDRA DS 750	IDRA DS 1000
70°C	l	374	438	659	863	1190	1530
60°C	l	284	375	531	675	877	1110
50°C	l	205	310	390	485	762	790

\* Solar coil sensor reference.

Double-coil cylinders IDRA DS 200-300-430-550-750-1000

# Pressure losses

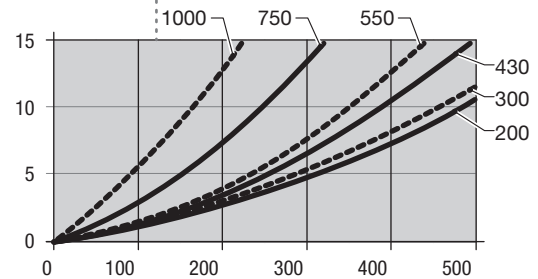
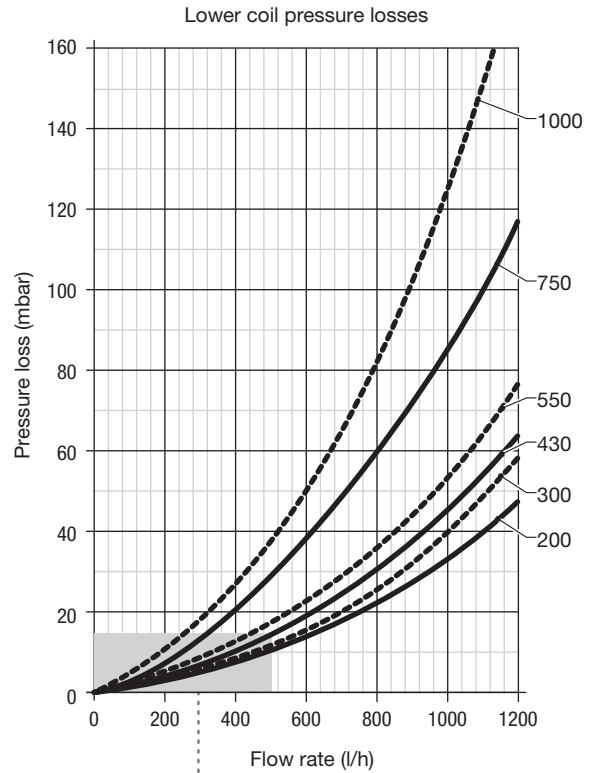
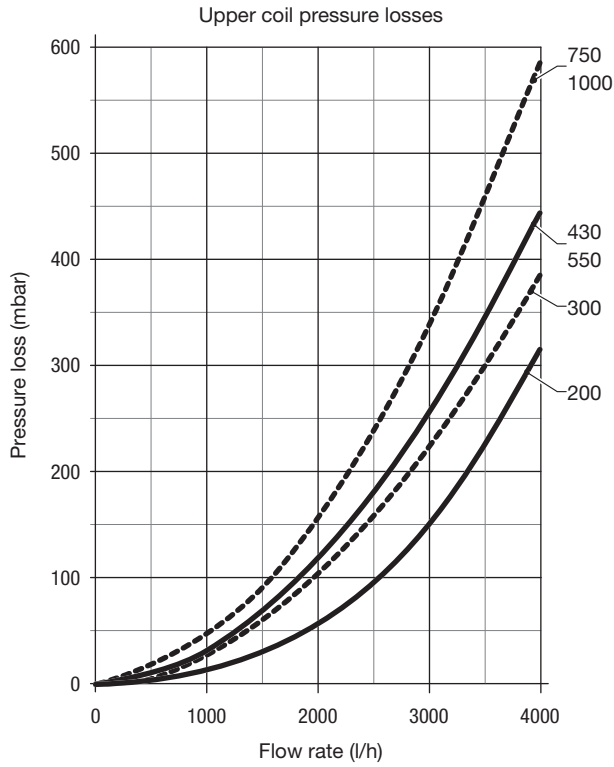

Values referred to a mix of water and 30% glycol.

# Structure

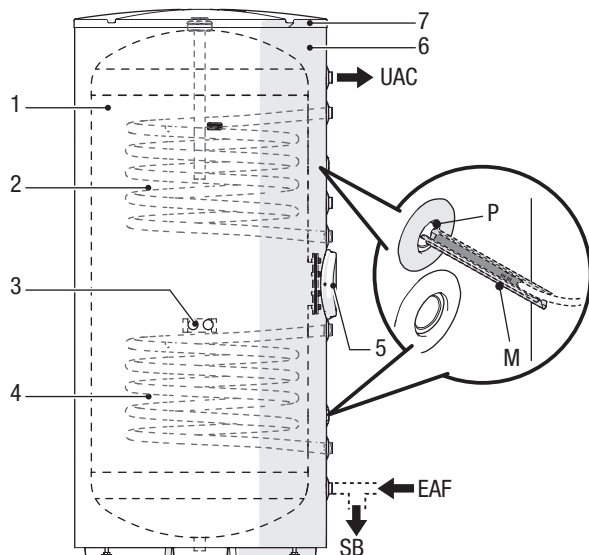

- 1. Cylinder
- 2. Upper coil
- 3. Prearranged for lifting handles (accessory) and/or grounding point
- 4. Lower coil
- 5. Flange for cylinder inspection and electrical cylinder (accessory)
- 6. Insulation
- 7. Cover
- P Pocket
- M Spring
- UAC Domestic hot water outlet
- EAF Domestic cold water inlet
- SB Cylinder drain

**Double-coil cylinders IDRA DS 200-300-430-550-750-1000**

# Overall dimensions and couplings

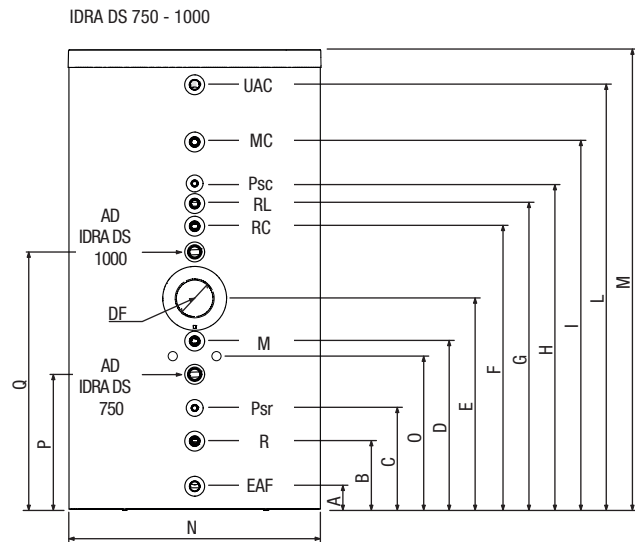
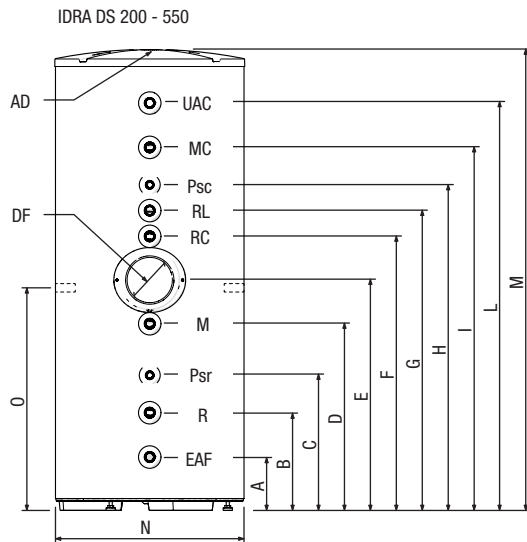

		IDRA DS 200	IDRA DS 300	IDRA DS 430	IDRA DS 550	IDRA DS 750	IDRA DS 1000
UAC - Domestic hot water outlet	Ø	1" M	1" M	1" M	1" M	1" M	1" M
MC - Boiler delivery line	Ø	1" M	1" M	1" M	1" M	1" M	1" M
RC - Boiler return line	Ø	1" M	1" M	1" M	1" M	1" M	1" M
M - Solar delivery line	Ø	1" M	1" M	1" M	1" M	1" M	1" M
R - Solar return	Ø	1" M	1" M	1" M	1" M	1" M	1" M
RL - DHW recirculation	Ø	1" M	1" M	1" M	1" M	1" M	1" M
EAF (SB) - Domestic cold water inlet (cylinder drain)	Ø	1" M	1" M	1" M	1" M	1" M	1" M
Psc - Diameter/length of boiler sensor pocket	mm	18/180	18/180	18/180	18/180	16/180	16/180
Psr - Diameter/length of solar regulation sensor pocket	mm	18/180	18/180	18/180	18/180	16/180	16/180
AD - Diameter/length of magnesium anode	mm	33/450	33/450	33/520	33/520	40/600	40/600
DF - Inside flange diameter	mm	130	130	130	130	130	130
A	mm	171	171	208	207	75	75
B	mm	243	253	329	348	289	289
C	mm	403	393	427	443	428	421
D	mm	598	693	684	788	799	834
E	mm	738	903	824	1088	969	1006
F	mm	878	1113	964	1328	1144	1337
G	mm	953	1233	1064	1428	1234	1426
H	mm	1029	1323	1174	1538	1321	1506
I	mm	1098	1438	1289	1653	1444	1637
L	mm	1170	1670	1440	1784	1707	2032
M	mm	1338	1838	1644	1988	1846	2171
N	mm	Ø 604	Ø 604	Ø 755	Ø 755	Ø 1000	Ø 1000
O - M8 threaded inserts for grounding point/fixing of accessory handles	mm	700	700	700	700	600	600
P	mm	-	-	-	-	555	-
Q	mm	-	-	-	-	-	1237

It is recommended to install shut-off valves at domestic water inlet and outlet.

When filling/loading the cylinder, check that the seals are properly sealing.

When a sensor is installed, any electric junction between sensor cable and extensions for the connection to the electric panel must be soldered and protected with a sheath or a suitable electric insulation.

## Double-coil cylinders IDRA DS 200-300-430-550-750-1000

### Cylinder installation room

Beretta IDRA DS cylinders can be installed in all rooms that do not require an electrical protection level higher than IP X0D. The installation room must be dry to prevent rusting. Maintain minimum clearances for maintenance and assembly.

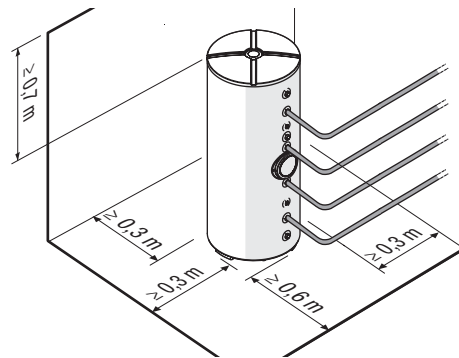

### Installation on old systems or systems requiring refurbishment

When IDRA DS solar cylinders are installed on old systems or systems to be upgraded, check that:

- The installation is carried out with safety and control devices in compliance with specific standards.
- The system is washed, cleaned of sludge, scale, de-aerated and the hydraulic seals have been checked.
- A treatment system is provided when the feed/top-up water is special (the reference values can be considered to be those shown in the table).

#### Inlet water values

pH	6-8
Electrical conductivity	less than 200 mV/cm (25 °C)
Chlorine ions	less than 50 ppm
Sulphuric acid ions	less than 50 ppm
Total iron	less than 0.3 ppm
Alkalinity M	less than 50 ppm
Total hardness	less than 35 °F
Sulphur ions	none
Ammonia ions	none
Silicon ions	less than 30 ppm

### Commissioning

Before starting up and functionally testing the cylinder, it is essential to check that:

- The water supply cocks of the DHW circuit are open.
- The hydraulic connections to the matched boiler and to the hydraulic unit of the solar system are properly made.

- The electrical connections have been carried out correctly (for 200 ÷ 550 models, use the flexible hoses provided for the passage of the cables).
- The procedure of washing and filling the solar circuit with the water-glycol mixture, and the simultaneous deaeration of the system, was carried out correctly.

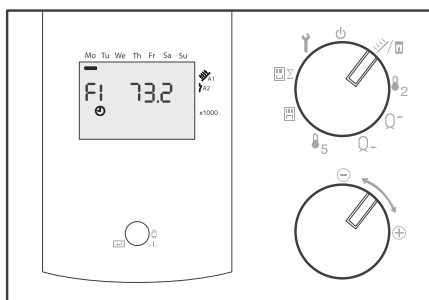

Heat transfer in the solar circuit occurs when the temperature of the solar collector is higher than that of the cylinder. Therefore, in the management of solar systems, the temperature difference is important rather than the exact temperature.

- Set the temperature difference between the collector and the cylinder (see the regulator operating instructions).
- Start up the boiler for the auxiliary heating of the cylinder.

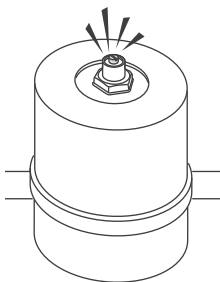

After start-up, make sure that:

- The solar circuit is completely vented.

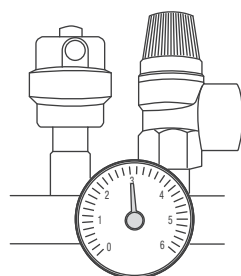

- The cold pressure of the system is about 3 bar.
- The safety valve trips at 6 bar.
- The pipes in the hydraulic circuit are insulated in accordance with the regulations in force.

If all conditions are met, restart the boiler and cylinder and check the regulated temperature and the amount of DHW that can be withdrawn.

## Double-coil cylinders IDRA DS 200-300-430-550-750-1000

### Hydraulic system configuration

In the presence of non-softened water, it is advisable to set the maximum temperature of the cylinder to 60°C, because at higher temperatures there is the formation of limescale with a consequent worsening of heat exchange.

In case of water supply from aqueduct with mains pressure higher than 6 bar, use a pressure reducing valve.

The non-return valve (5) must be fitted to the outlet of the solar coil. The expansion vessel must withstand high temperatures and the membrane must not be affected by the water-glycol mixture.

The DHW system **must include** the expansion vessel, the safety valve, the automatic breather valve and the cylinder drain cock.

The drain pipe of the safety valve must be connected to a suitable collection and drainage system. The manufacturer of the cylinder is not responsible for any flooding caused by the safety valve tripping.

**Use a thermostatic mixing valve (19) to limit the outlet temperature of the domestic hot water.**

If the pressure of the solar system decreases, **do not** top up with water but with a water-glycol mixture: danger of freezing.

All installed pipes, including collectors, heat exchangers and hydraulic devices, must undergo leak tests.

The choice and installation of the components of the system are the responsibility of the installer, who must operate according to best practice standards and current legislation.

The expansion vessel of the solar circuit must have characteristics that conform to the temperatures and pressures that can be present in that circuit.

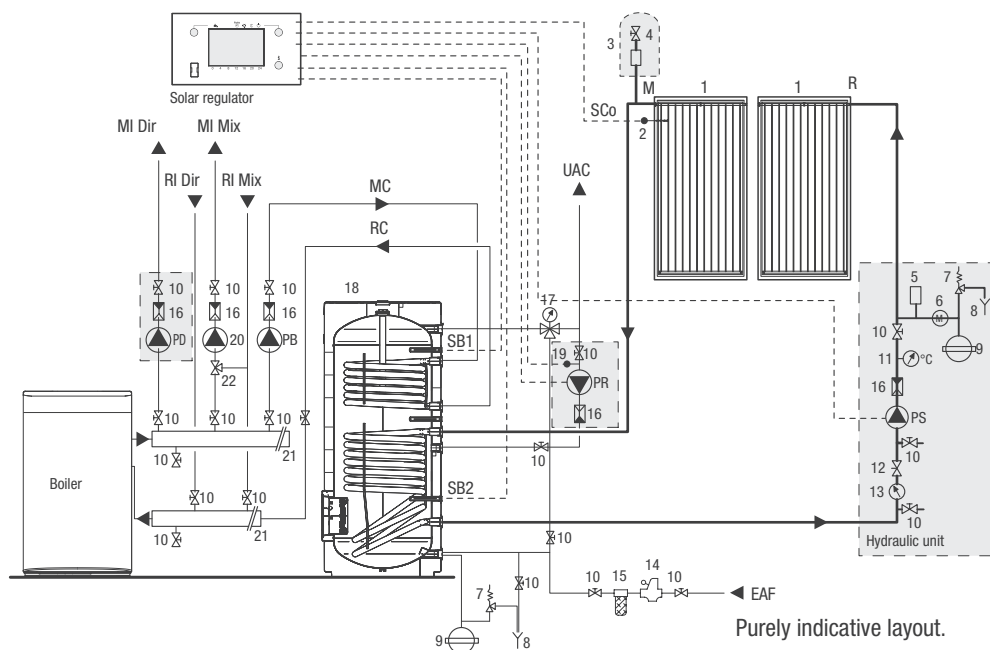

- |                              |                                    |
|------------------------------|------------------------------------|
| 1. Solar collector           | 21. System collectors              |
| 2. Collector sensor pocket   | 22. Mixing valve                   |
| 3. Manual degasser           | UAC Domestic hot water outlet      |
| 4. Drain cock                | EAF Domestic cold water inlet      |
| 5. Breather valve            | MI Mix Mixed system delivery line  |
| 6. Pressure gauge            | RI Mix Mixed system return line    |
| 7. Safety valve              | MI Dir Direct system delivery line |
| 8. Discharge                 | RI Dir Direct system return line   |
| 9. Expansion vessel          | MC Boiler delivery line            |
| 10. Shut-off valves          | RC Boiler return line              |
| 11. Thermometer              | M Collector delivery line          |
| 12. Flow regulator           | R Collector return line            |
| 13. Flowmeter                | PI Mix Mixed system pump           |
| 14. Pressure reducing valve  | PB Solar cylinder loading pump     |
| 15. Softener filter          | PR DHW recirculation pump          |
| 16. Non-return valve         | PD Direct system pump              |
| 17. Thermostatic mixer       | PS Solar circuit pump              |
| 18. Solar cylinder           | SB1 Upper cylinder sensor          |
| 19. DHW recirculation sensor | SB2 Lower cylinder sensor          |
| 20. System circulation pump  | SCo Collector sensor               |

## Double-coil cylinders

### IDRA DS FI 200 - 300 - 430 - 550



**vertical buffer tank cylinder in glazed steel**  
**double-coil heat exchanger**  
**ideal for solar systems**  
**pre-installed M/R hydraulic unit**  
**low-consumption circulation pump**  
**pre-installed Evosol solar control unit**  
**durability and hygiene guaranteed by glazing**  
**anode protection against stray currents**  
**high performance in hot water production and short recovery times**  
**effective thermal insulation and low pressure drop**  
**large heat exchange surface area of the lower coil**  
**5-year warranty**

The 200 - 300 - 430 - 550 litre double-coil solar cylinders of the FI series can be integrated into solar systems for the production of domestic hot water. The main technical elements in the design of the solar cylinder are:

- The accurate study of tank and coil geometries that allow to obtain the best performance in terms of stratification, heat exchange and recovery times.
- The internal glazing, bacteriologically inert, that ensures maximum hygiene of the treated water, reduces the possibility of limescale build-up and facilitates cleaning.
- The arrangement of the connections at different heights to use different types of heat generators, without affecting the stratification.
- The hydraulic unit and the solar control unit already installed at the factory, allow a significant reduction in installation time.
- CFC-free polyurethane insulation and an elegant outer housing to limit heat loss and therefore increase performance.
- The use of the flange to facilitate cleaning and maintenance and the magnesium anode with "anti-corrosion" function due to stray currents.

Predisposition for accessories:

- Solar expansion vessel of 18-24-35-50 litres.

## Double-coil cylinders IDRA DS FI 200 - 300 - 430 - 550

# Technical data sheet

Description	Unit	IDRA DS FI 200	IDRA DS FI 300	IDRA DS FI 430	IDRA DS FI 550
Cylinder type		Vertical, Glazed			
Exchanger layout		Vertical with elliptical section			
Cylinder capacity	l	208	301	442	551
Non-solar usable volume (Vbu)*	l	68	117	182	175
Solar usable volume (Vsol)**	l	140	184	260	376
Diameter of cylinder with insulation	mm	604	604	755	755
Diameter of cylinder with no insulation	mm	-	-	-	-
Height with insulation	mm	1338	1838	1644	1988
Height without insulation	mm	-	-	-	-
Insulation thickness	mm	50	50	50	50
Total net weight	kg	100	122	145	185
Diameter/length of magnesium anode	mm	33/450	33/450	33/520	33/520
Inside flange diameter	mm	130	130	130	130
Diameter/length of sensor-holder pockets	mm	18/180	18/180	18/180	18/180
Upper coil water content	l	3.4	4.5	6.0	6.0
Upper coil exchange surface	m <sup>2</sup>	0.7	0.8	1.0	1.0
Lower coil water content	l	3.4	5.1	7.5	9.0
Lower coil exchange surface	m <sup>2</sup>	0.7	1.0	1.4	1.8
Maximum cylinder operating pressure	bar	10	10	10	10
Maximum coil operating pressure	bar	10	10	10	10
Maximum operating temperature	°C	99	99	99	99
Dissipation according to EN 12897:2006 $\Delta T=45^{\circ}\text{C}$ (ambient temperature $20^{\circ}\text{C}$ and storage at $65^{\circ}\text{C}$ )	W	62	69	60	68
Heat loss according to UNI 11300	W/K	1.38	1.53	1.33	1.51
Energy class		B	B	B	B

\* Vbu - The non-solar useful volume expresses the amount of water (in litres) heated directly by the thermal integration coil. It is calculated as the volume between the upper part of the cylinder and the lower part of the thermal integration element (lower turn of the integration coil).

\*\* Vsol - The usable solar volume indicates the quantity of water (in litres) heated directly by the solar coil (placed in the lower part of the cylinder) minus the non-solar volume (Vbu).

## Performance referred to the integration coil

Upper coil continuous output (DHW  $10-45^{\circ}\text{C}$ ) (reference volume Vbu).

Coil delivery temperature		Unit	IDRA DS FI 200	IDRA DS FI 300	IDRA DS FI 430	IDRA DS FI 550
80°C	$\Delta T$ 20K	kW	16.1	23	31.4	31.4
		l/h	400	572	774	774
70°C	$\Delta T$ 20K	kW	10.3	17	20.7	20.7
		l/h	247	425	505	505
60°C	$\Delta T$ 20K	kW	11	15.5	15.5	15.5
		l/h	277	375	375	375
50°C	$\Delta T$ 20K	kW	2.4	5	7	7
		l/h	57	130	170	170

Set-up time required to heat the cylinder to  $60^{\circ}\text{C}$ , referred to the integration coil sensor, at various upper coil inlet temperatures with a coil inlet/outlet  $\Delta$  of  $20^{\circ}\text{C}$  (reference volume Vbu).

Upper coil delivery temperature		Unit	IDRA DS FI 200	IDRA DS FI 300	IDRA DS FI 430	IDRA DS FI 550
80°C	$\Delta T$ 20K	min	25	27	24	24
70°C	$\Delta T$ 20K	min	33	34	32	32
60°C	$\Delta T$ 20K	min	66	65	65	65

## Double-coil cylinders IDRA DS FI 200 - 300 - 430 - 550

Thermal output coefficient NL according to DIN 4708. The NL index, referred to the integration exchanger, indicates a number of apartments having 3.5 people that can be fully supplied, with a 140 litres and two other drawing points.

Upper coil delivery temperature	IDRA DS FI 200	IDRA DS FI 300	IDRA DS FI 430	IDRA DS FI 550
80°C	1.12	1.64	2.2	2.23
70°C	0.86	1.34	1.66	1.69
60°C	0.65	1.04	1.37	1.42

## Emptying in 10'

### Performance referred to the integration coil

Quantity of domestic water obtained in 10' with cylinder pre-heated to 60°C (\*) and primary exchanger at the indicated delivery temperature, considering an increase of the domestic water temperature of 30°C between inlet and outlet (according to EN 12897).

Upper coil delivery temperature	Unit	IDRA DS FI 200	IDRA DS FI 300	IDRA DS FI 430	IDRA DS FI 550
80°C	l	166	260	330	345
70°C	l	138	255	323	340
60°C	l	131	250	308	336

\* Integration coil sensor point reference, Vbu reference volume.

### Performance referred to the solar coil

Quantity of domestic water obtained in 10' with cylinder pre-heated to the indicated temperature (\*) considering an increase of the domestic water temperature of 30°C between inlet and outlet (according to EN 12897).

Storage bottom temperature	Unit	IDRA DS FI 200	IDRA DS FI 300	IDRA DS FI 430	IDRA DS FI 550
70°C	l	374	438	659	863
60°C	l	284	375	531	675
50°C	l	205	310	390	485

\* Solar coil sensor reference.

## Solar station technical data

Description	Unit	
Safety valve calibration pressure	bar	6
Maximum operating temperature	°C	110
Electrical power supply	V-Hz	230~50
Absorbed electrical current min/ max	A	0.08 ÷ 0.58
Power input min/max	W	5 ÷ 63

Double-coil cylinders IDRA DS FI 200 - 300 - 430 - 550

# Pressure losses

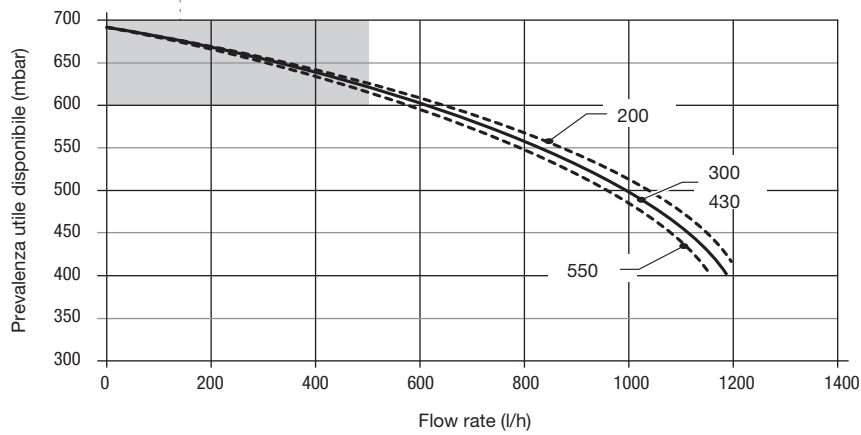
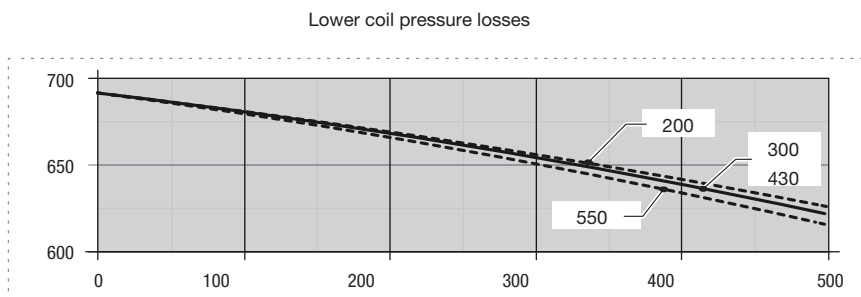
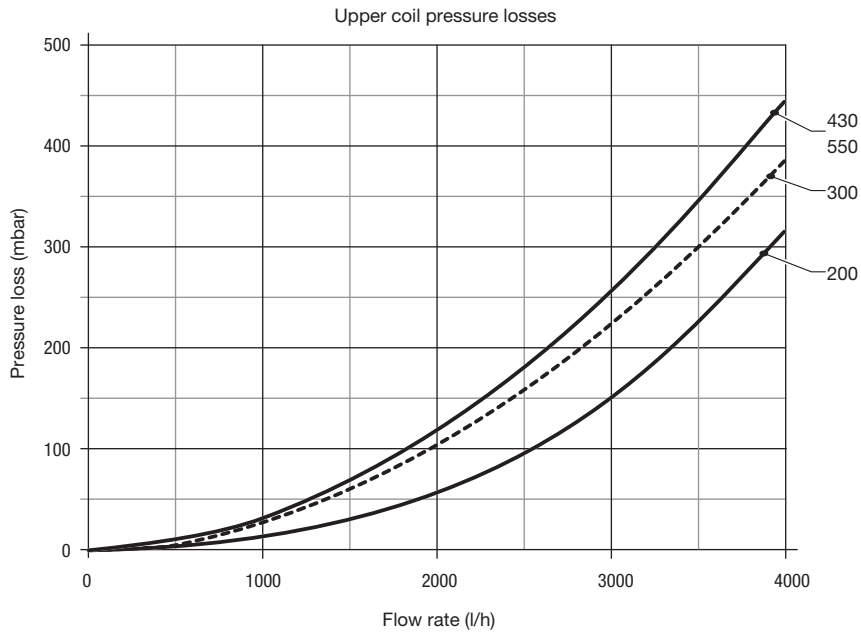

Double-coil cylinders IDRA DS FI 200 - 300 - 430 - 550

# Structure

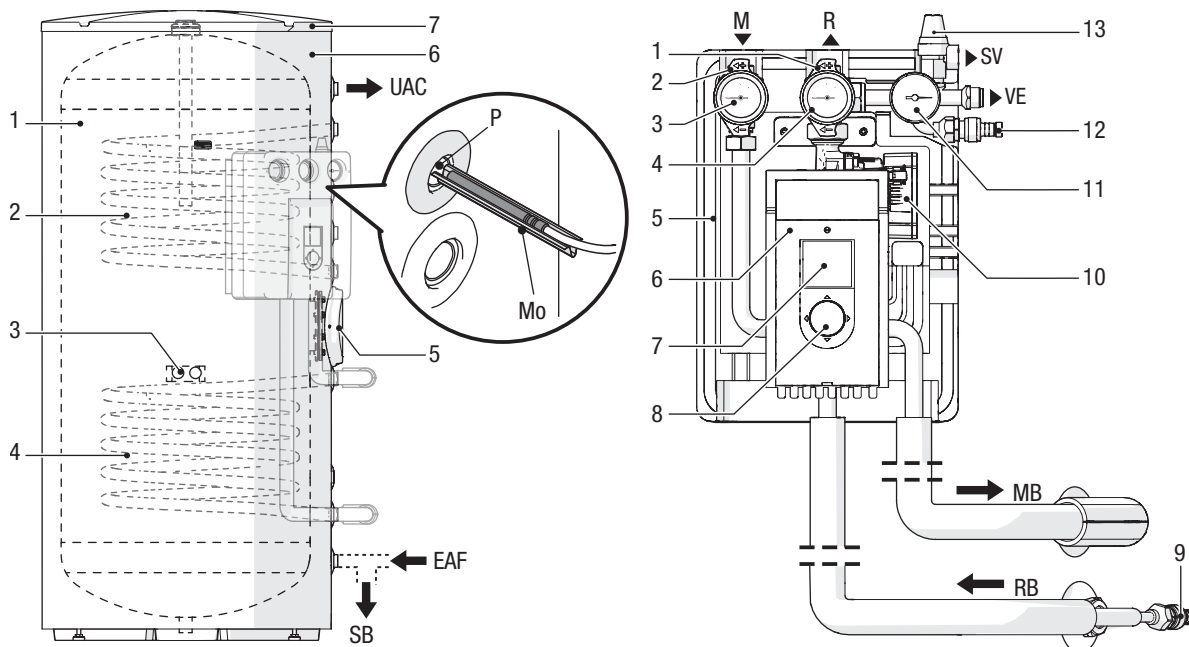

**Cylinder**

- 1. Cylinder
- 2. Upper coil
- 3. Prearranged for lifting handles (accessory) and/or grounding point
- 4. Lower coil
- 5. Flange for cylinder inspection and electrical cylinder (accessory)
- 6. Insulation
- 7. Cover
- P Pocket
- Mo Spring
- UAC Domestic hot water outlet
- EAF Domestic cold water inlet
- SB Cylinder drain

**Solar station**

- 1. Return valve (solar system return line) with integrated non-return valve
- 2. Delivery valve (solar system delivery line) with integrated non-return valve
- 3. Delivery thermometer
- 4. Return thermometer
- 5. Insulation
- 6. Solar regulator
- 7. Display
- 8. Multidirectional joystick
- 9. System load/unload valve A
- 10. Circulation pump
- 11. Pressure gauge
- 12. System load/unload valve B
- 13. Safety valve (6 bar)
- M Solar delivery line Inlet of heat transfer fluid from solar collector
- R Solar return. Outlet of heat transfer fluid towards solar collector
- MB Cylinder delivery line. Outlet of heat transfer fluid towards solar cylinder
- RB Cylinder return line. Inlet of heat transfer fluid from solar cylinder
- SV Safety valve drain
- VE Expansion vessel connection

**Double-coil cylinders IDRA DS FI 200 - 300 - 430 - 550**

# Hydraulic connections

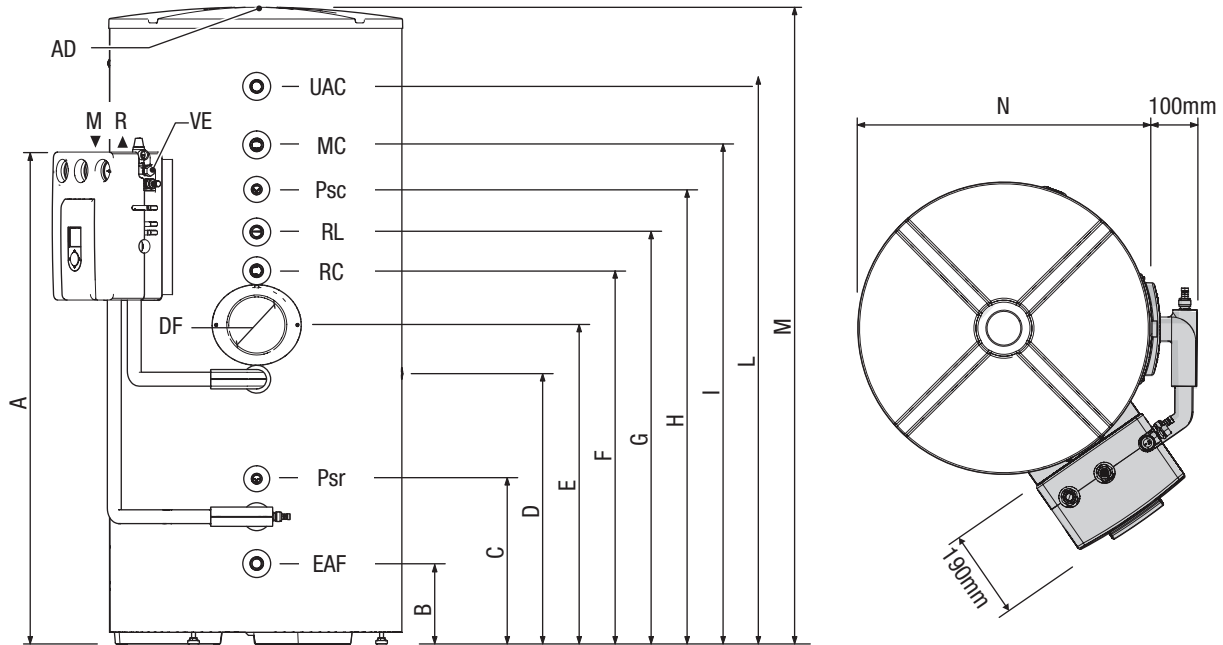

		IDRA DS 200 FI	IDRA DS 300 FI	IDRA DS 430 FI	IDRA DS 550 FI
VE - Expansion vessel connection	Ø	1/2" M	1/2" M	1/2" M	1/2" M
UAC - Domestic hot water outlet	Ø	1" M	1" M	1" M	1" M
MC - Boiler delivery line	Ø	1" M	1" M	1" M	1" M
RC - Boiler return line	Ø	1" M	1" M	1" M	1" M
M - Solar delivery line	Ø	1" M	1" M	1" M	1" M
R - Solar return	Ø	1" M	1" M	1" M	1" M
RL - DHW recirculation	Ø	1" M	1" M	1" M	1" M
EAF (SB) - Domestic cold water inlet (cylinder drain)	Ø	1" M	1" M	1" M	1" M
Psc - Diameter/length of boiler sensor pocket	mm	18/180	18/180	18/180	18/180
Psr - Diameter/length of solar regulation sensor pocket	mm	18/180	18/180	18/180	18/180
AD - Diameter/length of magnesium anode	mm	33/450	33/450	33/520	33/520
DF - Inside flange diameter	mm	130	130	130	130
A	mm	1120	1420	1270	1570
B	mm	171	171	208	207
C	mm	403	393	427	443
D - M8 threaded inserts for grounding point/fixing of accessory handles	mm	700	700	700	700
E	mm	738	903	824	1088
F	mm	878	1113	964	1328
G	mm	953	1233	1064	1428
H	mm	1029	1323	1174	1538
I	mm	1098	1438	1289	1653
L	mm	1170	1670	1440	1784
M	mm	1338	1838	1644	1988
N	mm	Ø 604	Ø 604	Ø 755	Ø 755

It is recommended to install shut-off valves at domestic water inlet and outlet.

When filling/loading the cylinder, check that the seals are properly sealing.

Any electric junction between sensor cable and extensions for the connection to the electric panel must be soldered and protected with a sheath or a suitable electric insulation.

## Double-coil cylinders IDRA DS FI 200 - 300 - 430 - 550

### Cylinder installation room

Beretta IDRA DS FI cylinders can be installed in all rooms that do not require an electrical protection level higher than IP X0D. The installation room must be dry to prevent rusting. Maintain minimum clearances for maintenance and assembly.

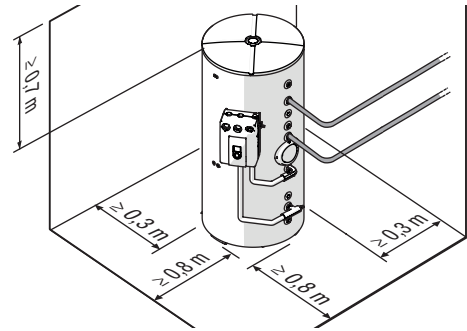

### Installation on old systems or systems requiring refurbishment

When IDRA DS FI solar cylinders are installed on old systems or systems to be upgraded, check that:

- The installation is carried out with safety and control devices in compliance with specific standards.
- The system is washed, cleaned of sludge, scale, de-aerated and the hydraulic seals have been checked.
- A treatment system is provided when the feed/top-up water is special (the reference values can be considered to be those shown in the table).

#### Inlet water values

pH	6-8
Electrical conductivity	less than 200 mV/cm (25 °C)
Chlorine ions	less than 50 ppm
Sulphuric acid ions	less than 50 ppm
Total iron	less than 0.3 ppm
Alkalinity M	less than 50 ppm
Total hardness	less than 35 °F
Sulphur ions	none
Ammonia ions	none
Silicon ions	less than 30 ppm

### Positioning the sensors

Beretta IDRA DS FI cylinders are equipped with a pocket in which the sensors for the thermostat and, if necessary, the cylinder thermometer must be placed.

The connections to the boiler or to the thermal unit are the responsibility of the installer, who must operate according to best practice standards and current legislation.

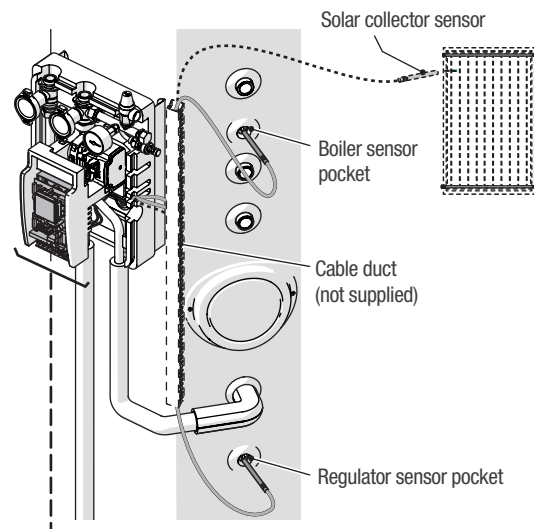

### Preparation for initial commissioning

- Connect the outlet of the safety valve to a pipe (T) to recover any spillage of the solar fluid and to avoid scalding.
- Connect the expansion vessel (E) suitable for applications in solar systems.
- Connect the circulation pump and the sensors to the solar regulator (if any) as described in the instruction manual supplied with the regulator.

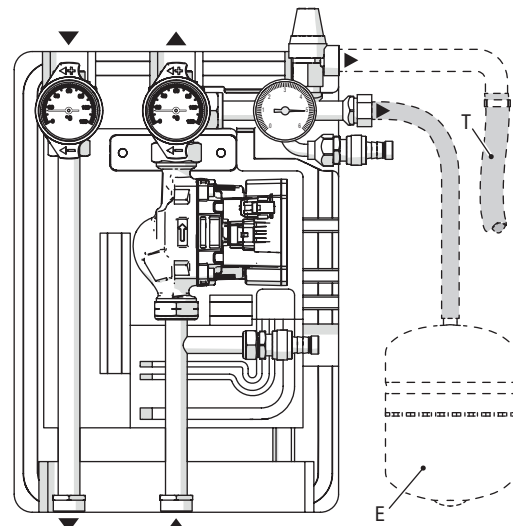

## Double-coil cylinders IDRA DS FI 200 - 300 - 430 - 550

Position of the handle of the VM - VR valves

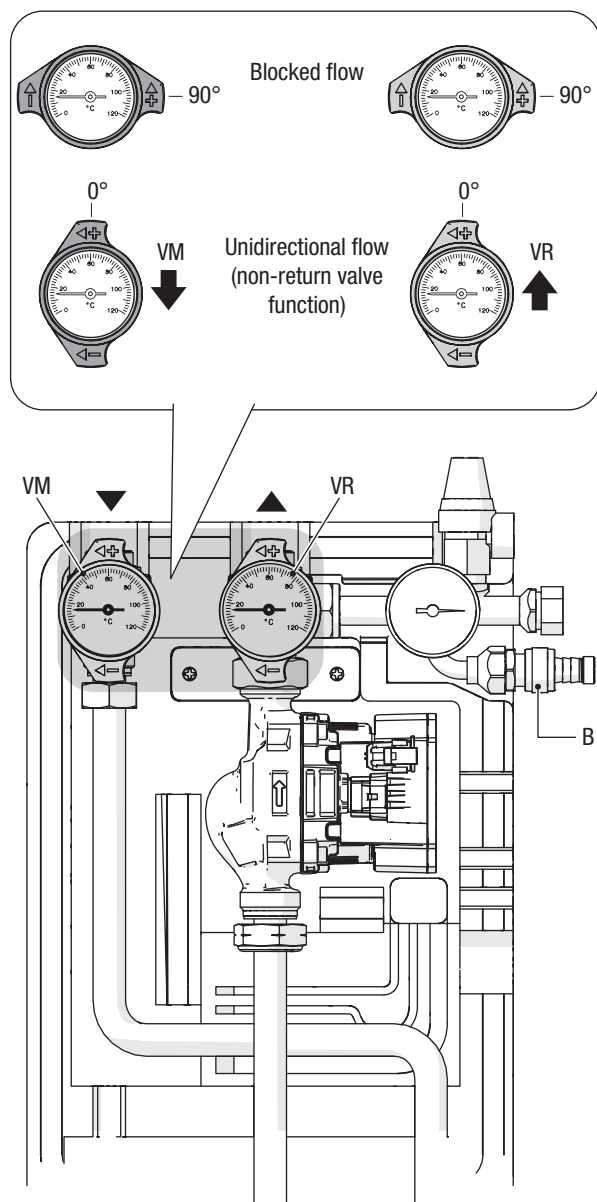

## System flushing

Before loading the system with the mixture of water and glycol, it is necessary to flush the inside of the solar circuit pipes to eliminate any residue and dirt.

- Turn the valve handle (VR) clockwise.
- Open taps (A) and (B) on the return tube.
- Fill water from the cock (B) and wait for it to flow out of cock (A).
- Allow water to come out for at least 30 seconds.
- Turn the valve handle (VR) counter clockwise.
- Close the cocks (A) and (B).

Be careful when flushing the system if water escapes from the cocks: steam may form with risk of scalding. Use appropriate personal protection equipment.

If copper pipes have been used and brazing has been carried out, it is necessary to flush the system to remove the residues of the brazing flux. Then perform the leak test.

The solar circuit must be filled immediately with a mixture of water and glycol, which serves as protection against the danger of frost and corrosion protection.

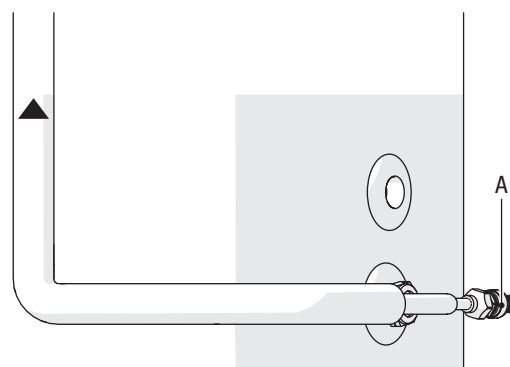

## Water + glycol pre-mixing

Before filling the system, the separately supplied glycol must be premixed with water in a container. For example, 40% glycol and 60% water allow for a frost resistance up to a temperature of -21 °C.

Antifreeze	Temperature	Density
50%	-32 °C	1.045 kg/dm <sup>3</sup>
40%	-21 °C	1.037 kg/dm <sup>3</sup>
30%	-13 °C	1.029 kg/dm <sup>3</sup>

The propylene glycol supplied is specially designed for solar applications as it maintains its characteristics in the range -32 ÷ 180 °C.

It is also non-toxic, biodegradable and biocompatible.

Do not fill pure glycol into the system and then add water.

Do not use manual or automatic filling systems.

If the chlorine content is very high, distilled water must be used for the mixture.

## Double-coil cylinders IDRA DS FI 200 - 300 - 430 - 550

### System filling

Before filling the system:

- Cut power off to the solar station and to the connected integration system, by setting the system's main switch and the device's main switch to OFF.

Always use a mixture of water and glycol suitable for solar applications. Choose the mixture according to the minimum temperature that can be reached at the installation site and the maximum operating temperature of the solar collectors. Refer to the glycol safety data sheet for more information.

In case of non-premixed glycol:

- Do not fill pure glycol into the system and then add water.
- Check that the features of the filling water comply with the regulations in force, otherwise the filling water must be treated. For example, use portable treatment systems. In particular, if the chlorine content is very high (> 50ppm), distilled water must be used for the mixture.

To fill the system, proceed as follows:

- Connect the load pump (PC) as shown in the figure. Turn the valve handle (VR) clockwise. Open taps (A) and (B) on the return tube.
- Open the manual degasser cock and any vents, located at the highest points of the system, and keep them open throughout the loading operation.
- Circulate the heat transfer fluid with an external pump until all air bubbles are eliminated. Close the manual degasser cock and any vents that have previously been opened.
- Turn the valve handle (VR) counter clockwise.
- Briefly increase the system pressure to 4 bar.
- Start up the system for about 20 minutes.
- Repeat the air bleeding operation until the system is completely de-aerated.
- set the system pressure.
- Close the cocks (A) and (B).

The set pressure must ensure that the one measured at the solar collectors is positive with respect to the ambient one (avoid depression in the solar field) and must be set considering both the safety valve opening pressure (6 bar) and the solar expansion vessel pre-charge pressure. To set the system pressure correctly, refer to the design manual.

Do not fill the system with strong sunlight and collectors at high temperature.

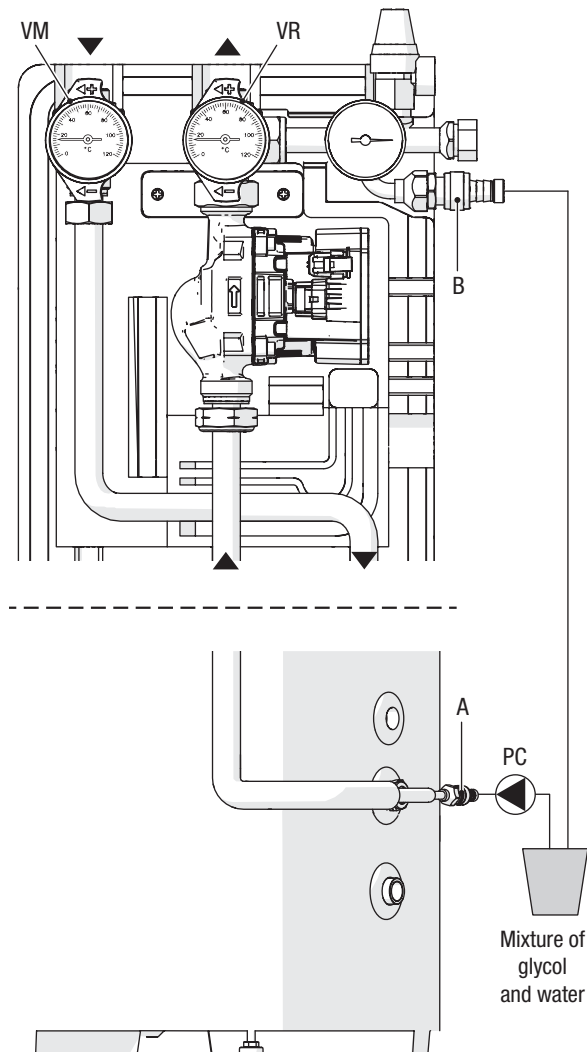

Make sure that you have completely eliminated the air bubbles from the system by using a manual degasser to be installed at the highest point of the system.

### Checks during and after initial commissioning

After start-up, make sure that:

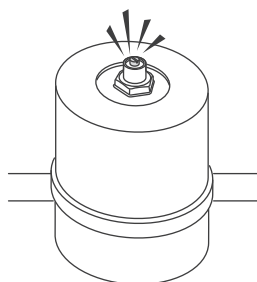

The solar circuit is completely vented.

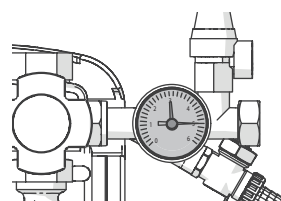

The cold pressure of the system is about 3 bar.  
The safety valve trips at 6 bar.  
The pipes in the hydraulic circuit are insulated in accordance with the regulations in force.

If all conditions are met, restart the boiler and cylinder and check the regulated temperature and the amount of DHW that can be withdrawn.

## Double-coil cylinders IDRA DS FI 200 - 300 - 430 - 550

### Hydraulic system configuration

In the presence of non-softened water, it is advisable to set the maximum temperature of the cylinder to 60°C, because at higher temperatures there is the formation of limescale with a consequent worsening of heat exchange.

In case of water supply from aqueduct with mains pressure higher than 6 bar, use a pressure reducing valve.

The expansion vessel must withstand high temperatures and the membrane must not be affected by the water-glycol mixture.

The DHW system **must include** the expansion vessel, the safety valve, the automatic breather valve and the cylinder drain cock.

The drain pipe of the safety valve must be connected to a suitable collection and drainage system. The manufacturer of the cylinder is not responsible for any flooding caused by the safety valve tripping.

**Use a thermostatic mixing valve (14) to limit the outlet temperature of the domestic hot water.**

If the pressure of the solar system decreases, **do not** top up with water but with a water-glycol mixture: danger of freezing.

All installed pipes, including collectors, heat exchangers and hydraulic devices, must undergo leak tests.

The choice and installation of the components of the system are the responsibility of the installer, who must operate according to best practice standards and current legislation.

The expansion vessel of the solar circuit must have characteristics that conform to the temperatures and pressures that can be present in that circuit.

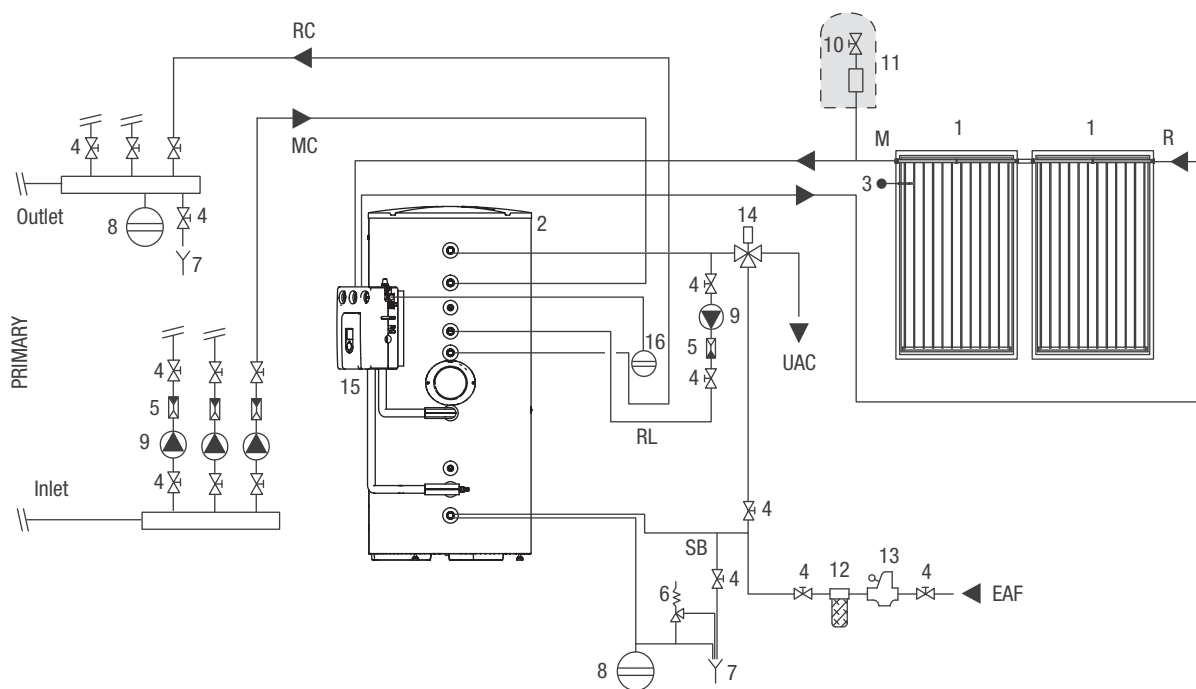

- 1. Solar collector
- 2. Beretta IDRA DS FI solar cylinder
- 3. Collector sensor
- 4. Shut-off valves
- 5. Non-return valve
- 6. Safety valve
- 7. Discharge
- 8. Expansion vessel (not supplied)
- 9. Circulation pump
- 10. Drain cock
- 11. Manual degasser (accessory)
- 12. Softener filter
- 13. Pressure reducing valve
- 14. Mixing valve
- 15. Solar regulator
- 16. Solar expansion vessel (accessory)

- UAC Domestic hot water outlet
- MC Boiler delivery line
- RC Boiler return line
- M Collector delivery line
- R Collector return line
- RL Domestic recirculation
- EAF Domestic cold water inlet
- SB Cylinder drain

## Double-coil cylinders IDRA N DS 1500 - 2000



**vertical buffer tank cylinder in glazed steel**  
**storage tank with double-coil heat exchanger**  
**ideal for solar systems**  
**durability, hygiene and temperatures up to 99 °C guaranteed**  
**by double glazing**  
**anodic corrosion protection**  
**high performance in hot water production and short recovery**  
**times**  
**effective thermal insulation and low pressure drop**  
**large heat exchange surface area of the lower coil**  
**anodic corrosion protection**  
**easy access to the lower coil**  
**double coil for creating multiple system configurations**  
**prearranged cable routing**  
**5-year warranty**

The IDRA N DS double-coil solar cylinders, of 1500 and 2000 litres capacity, can be integrated in solar systems for the production of domestic hot water with Beretta solar collectors.

The main technical elements in the design of the solar cylinder are:

- The accurate study of tank and coil geometries that allow to obtain the best performance in terms of stratification, heat exchange and recovery times.
- The internal coating, bacteriologically inert, that ensures maximum hygiene of the treated water, reduces the possibility of limescale build-up and facilitates cleaning.
- The arrangement of the connections at different heights to use different types of heat generators, without affecting the stratification.
- CFC-free polyurethane insulation and an elegant outer housing to limit heat loss and therefore increase performance.
- The use of the flange to facilitate cleaning and maintenance and the magnesium anode with "anti-corrosion" function.

The IDRA N DS cylinders can be equipped with a specific solar regulator and can be easily integrated into solar systems in which Beretta boilers or thermal units are used as auxiliary heat generators.

## Double-coil cylinders IDRA N DS 1500 - 2000

# Technical data sheet

Description	Unit	IDRA N DS 1500	IDRA N DS 2000
Cylinder type		glazed	glazed
Cylinder layout		vertical	vertical
Exchanger layout		vertical	vertical
Cylinder capacity	l	1390	1950
Non-solar (Vbu) (**) / solar (Vsol) (***) usable volume	l	525 / 865	800 / 1150
Diameter of cylinder with insulation/ with no insulation	mm	1200 / 1000	1300 / 1100
Height with insulation/ with no insulation	mm	2185 / 2120	2470 / 2370
Insulation thickness	mm	100	100
First magnesium anode (Ø × length)	mm	32 × 700	32 × 700
Second magnesium anode (Ø × length)	mm	32 × 400	32 × 400
External / internal flange diameter	mm	290 / 220	290 / 220
Diameter/length of sensor-holder pockets	mm	8 / 200	8 / 200
Sleeve for heating element (not supplied)	Ø	1"1/2	1"1/2
Lower/upper coil water content	l	19.4 / 10.4	28.1 / 16.9
Lower/upper coil exchange surface	m <sup>2</sup>	3.4 / 1.8	4.6 / 2.8
Power absorption (*) of lower/upper coil	kW	88 / 47	120 / 73
Domestic hot water production (*) - lower / upper coil	l/h	2200 / 1200	2900 / 1800
Required flow rate of the lower/upper coil (*)	m <sup>3</sup> /h	3.8 / 2.0	5.2 / 3.1
Maximum cylinder/coil operating pressure	bar	8 / 10	8 / 10
Maximum cylinder/coil operating temperature	°C	99 / 110	99 / 110
Heat dissipation (UNI EN 12897/06) ΔT = 45 K	W (W/K)	162 (3.6)	186 (4.1)
NL index		55	84
Net weight with insulation	kg	325	540

(\*) According to DIN 4708, in order to obtain heating hot water production with ΔT= 20K (80/60°C) on the coil, it is necessary to comply with the values for absorbed power and flow rate required by the coil shown in the table.

Vbu(\*\*) The non-solar useful volume expresses the amount of water (in litres) heated directly by the cylinder upper coil. It is calculated as the volume between the upper part of the tank and the lower turn of the upper coil.

Vsol (\*\*\*) The usable solar volume indicates the quantity of water (in litres) heated directly by the solar coil (placed in the lower part of the cylinder) minus the non-solar volume (Vbu).

## Pressure losses

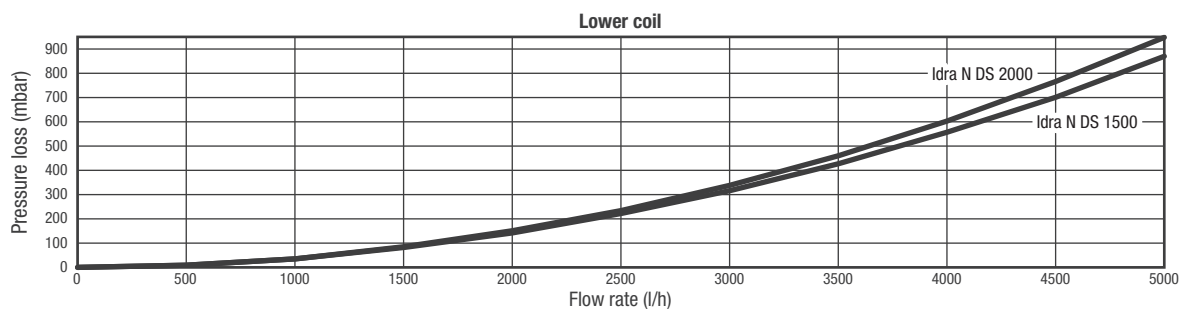
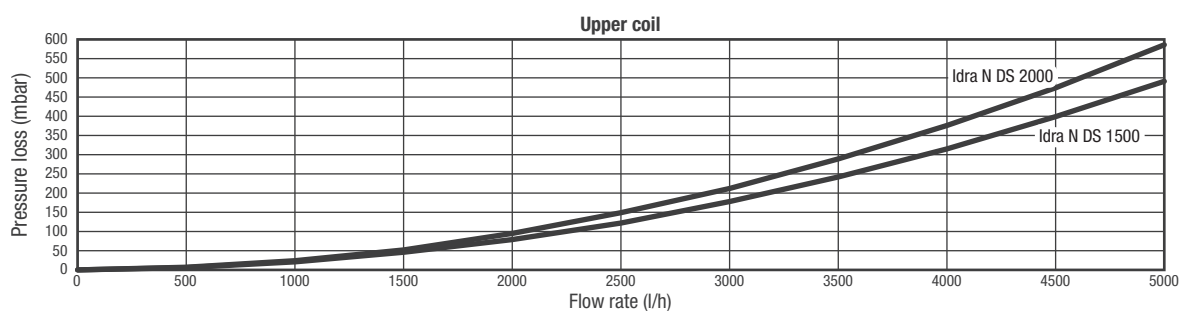

Double-coil cylinders IDRA N DS 1500 - 2000

# Structure

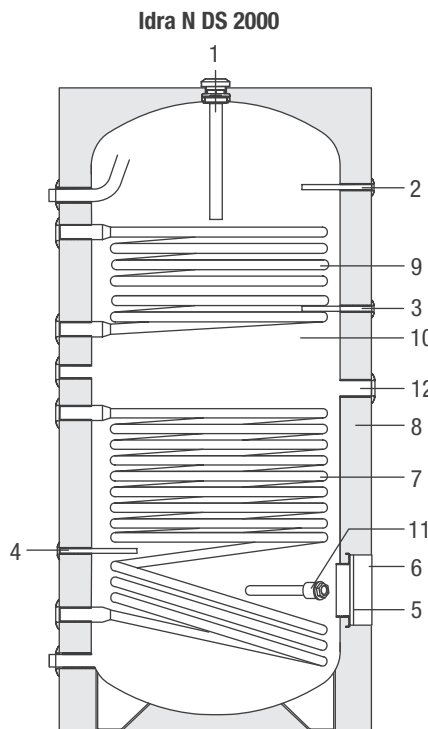
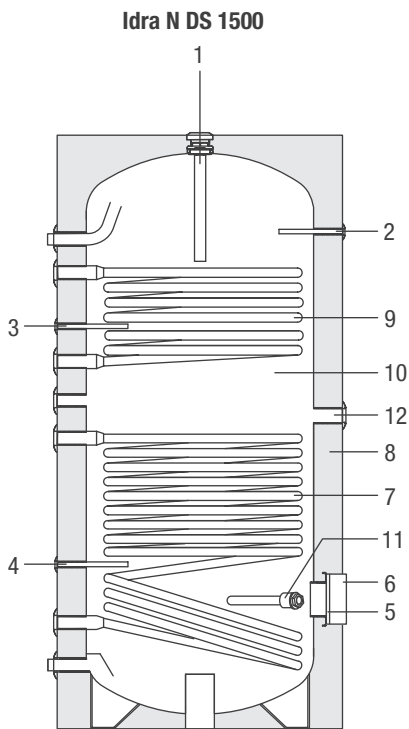

- 1. First magnesium anode
- 2. Boiler sensor pocket
- 3. Auxiliary pocket
- 4. Solar regulation sensor pocket
- 5. Flange for tank inspection
- 6. Flange cover
- 7. Lower coil
- 8. Polyurethane insulation
- 9. Upper coil
- 10. Tank
- 11. Second magnesium anode
- 12. Electric heater sleeve (not supplied)

# Dimensions

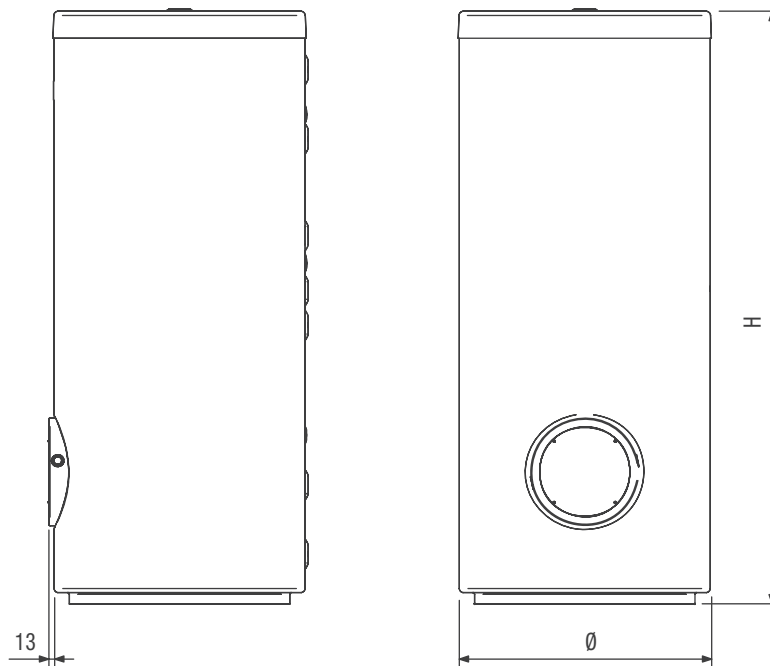

Description	Unit	IDRA N DS 1500	IDRA N DS 2000
H - Height	mm	2185	2470
Ø - Diameter	mm	1200	1300

## Double-coil cylinders IDRA N DS 1500 - 2000

### Hydraulic connections

Beretta IDRA N DS cylinders can be connected to existing heat generators, as long as they have an adequate heat output and

respect the hydraulic flow direction. The characteristics of the hydraulic connections are as follows.

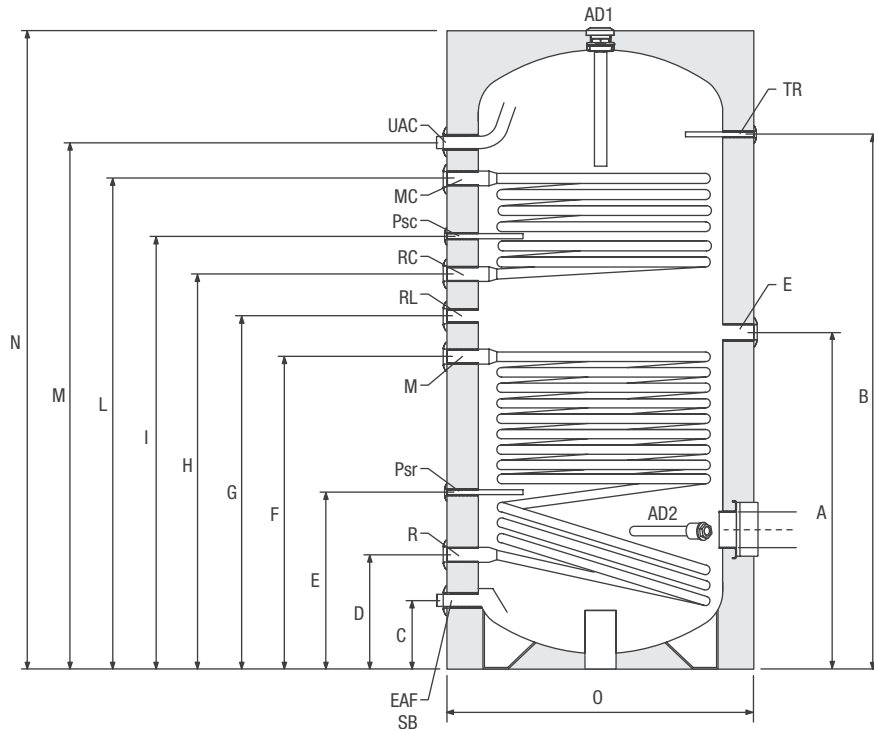

		IDRA DS 1500	IDRA DS 2000
UAC - Domestic hot water outlet	Ø	1"1/2 F	1"1/2 F
MC - Boiler delivery line	Ø	1"1/4 F	1"1/4 F
RC - Boiler return line	Ø	1"1/4 F	1"1/4 F
M - Solar delivery line	Ø	1"1/4 F	1"1/4 F
R - Solar return	Ø	1"1/4 F	1"1/4 F
RL - DHW recirculation	Ø	1" F	1" F
EAF (SB) - Domestic cold water inlet (cylinder drain)	Ø	1"1/2 F	1"1/2 F
Psc - Diameter/length of boiler sensor pocket	Ø/mm	1/2" F	1/2" F
Psr - Diameter/length of solar regulation sensor pocket	Ø/mm	1/2" F	1/2" F
RE - Sleeve for heating element (not supplied)	Ø	1"1/2 F	1"1/2 F
AD1 - Diameter/length of magnesium anode	Ø/mm	32 × 700	32 × 700
AD2 - Diameter/length of magnesium anode	Ø/mm	32 × 400	32 × 400
TR - Thermometer	Ø	1/2" F	1/2" F
A	mm	1230	1340
B	mm	1820	2000
C	mm	280	260
D	mm	415	400
E	mm	525	660
F	mm	1125	1205
G	mm	1220	1315
H	mm	1315	1425
I	mm	1410	1485
L	mm	1720	1870
M	mm	1870	1990
N	mm	2185	2470
O	mm	1200	1300

It is recommended to install shut-off valves in the delivery and return lines.

### Double-coil cylinders IDRA N DS 1500 - 2000

## Hydraulic circuit

The IDRA N DS solar cylinder is not equipped with load circulation pumps that must be suitably sized and installed on the system. For the recommended flow rate of the solar circuit, refer to the installation instructions of the solar collector and the Beretta manual for the commissioning and maintenance of the solar system. For IDRA N DS 1500 models, the second anode at the flange is supplied as standard and should be installed by the installer. For IDRA N DS 2000 models, the anodes are supplied as standard and should be installed by the installer.

## Positioning the sensors

The IDRA N DS boilers are equipped with sensor pockets, in which the sensors of the solar regulator and the boiler must be inserted.

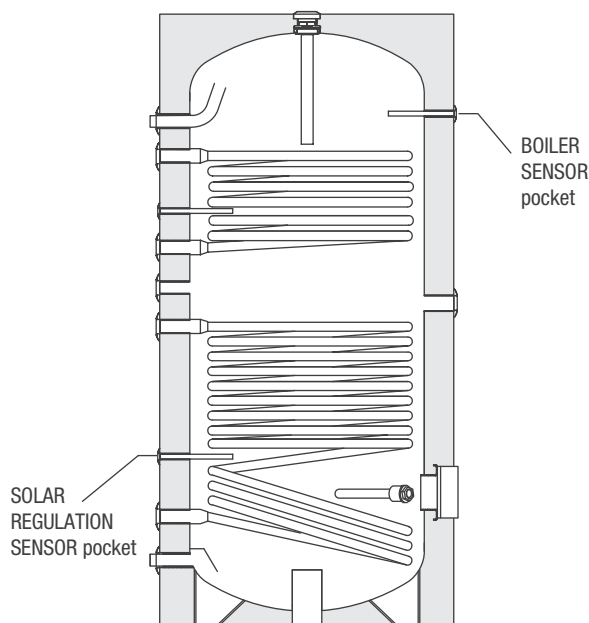
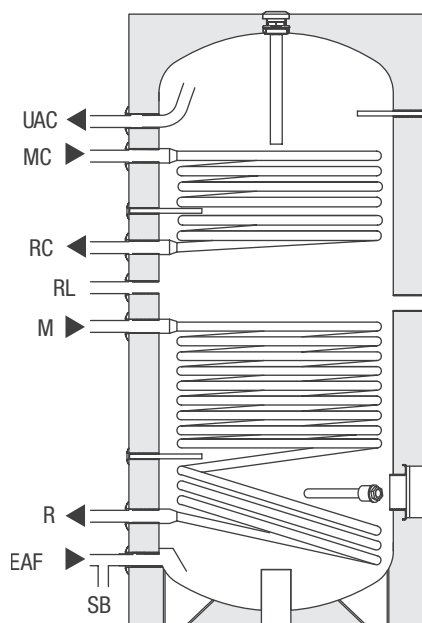

- UAC Domestic hot water outlet
- RL Domestic recirculation
- EAF Domestic cold water inlet
- SB Cylinder drain

**Boiler**

- MC Delivery line
- RC Return line

**Solar system**

- M Delivery line
- R Return line

## Double-coil cylinders IDRA N DS 1500 - 2000

### Hydraulic system configuration

In the presence of non-softened water, it is advisable to set the maximum temperature of the cylinder to 60 °C, because at higher temperatures there is the formation of limescale with a consequent worsening of heat exchange.

Before commissioning the solar system, the cylinder must be filled with water.

In case of water supply from aqueduct with mains pressure higher than 6 bar, use a pressure reducing valve.

The expansion vessel must withstand high temperatures and the membrane must not be affected by the water-glycol mixture.

The DHW system **must include** the expansion vessel, the safety valve, the automatic breather valve and the cylinder drain cock.

The drain pipe of the safety valve must be connected to a suitable collection and drainage system. The manufacturer of the cylinder is not responsible for any flooding caused by the safety valve tripping. **Use a thermostatic mixing valve (19) to limit the outlet temperature of the domestic hot water.**

If the pressure of the solar system decreases, **do not** top up with water but with a water-glycol mixture: danger of freezing.

All installed pipes, including collectors, heat exchangers and hydraulic devices, must undergo leak tests.

The choice and installation of the components of the system are the responsibility of the installer, who must operate according to best practice standards and current legislation.

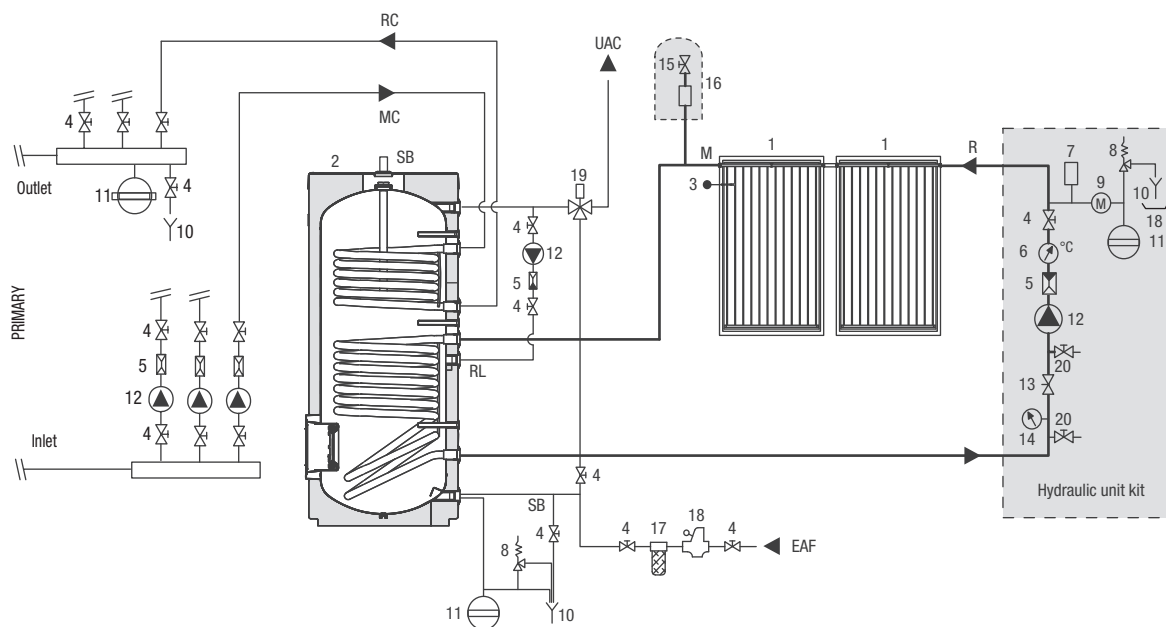

- 1. Solar collector
- 2. Cylinder
- 3. Collector sensor
- 4. Shut-off valves
- 5. Non-return valve
- 6. Thermometer
- 7. Breather valve
- 8. Safety valve
- 9. Pressure gauge
- 10. Discharge
- 11. Expansion vessel
- 12. Circulation pump
- 13. Flow regulator
- 14. Flowmeter
- 15. Drain cock
- 16. Manual degasser (accessory)
- 17. Softener filter
- 18. Pressure reducing valve
- 19. Thermostatic mixing valve
- 20. Heat transfer fluid recovery

- UAC Domestic hot water outlet
- MB Cylinder delivery line
- RB Cylinder return line
- M Collector delivery line
- R Collector return line
- RL Domestic recirculation
- EAF Domestic cold water inlet
- SB Cylinder drain
- MC Boiler delivery line
- RC Boiler return line

## Flanged solar cylinders IDRA PLUS DS 1000 - 1500 - 2000 - 3000



**vertical storage tank solar cylinder in glazed steel**  
**possibility of inserting up to three copper coil heat exchangers**  
**durability and hygiene guaranteed by glazing**  
**double anodic corrosion protection**  
**high performance in hot water production and short recovery times**  
**effective thermal insulation and low pressure drop**  
**multiple system configurations possible**  
**5-year warranty**

The IDRA PLUS DS solar cylinders, of 1000, 1500, 2000 and 3000 litres capacity, can be integrated in solar systems for the production of domestic hot water with Beretta solar collectors.

The main technical elements in the design of the solar cylinder are:

- The accurate study of tank geometries that allow to obtain the best performance in terms of stratification, heat exchange and recovery times.
- The arrangement of the connections at different heights to use different types of heat generators, without affecting the stratification.
- CFC-free polyurethane insulation and an elegant outer housing to limit heat loss and therefore increase performance.
- The use of three flanges allows the use of additional heat exchangers.

The IDRA PLUS DS cylinders can be equipped with a specific solar regulator and can be easily integrated into solar systems in which BERETTA boilers or thermal units are used as auxiliary heat generators.

**Flanged solar cylinders IDRA PLUS DS 1000 - 1500 - 2000 - 3000**

# Technical data sheet

Description	Unit	IDRA PLUS DS 1000	IDRA PLUS DS 1500	IDRA PLUS DS 2000	IDRA PLUS DS 3000
Cylinder type		glazed	glazed	glazed	glazed
Cylinder layout		vertical	vertical	vertical	vertical
Exchanger layout		horizontal	horizontal	horizontal	horizontal
Cylinder capacity	l	955	1430	1990	2959
Non-solar (Vbu) (*) / solar (Vsol) (**) usable volume	l	490 / 465	790 / 640	1210 / 780	1745 / 1214
Diameter of cylinder with insulation/ with no insulation	mm	990/790	1200/1000	1300/1100	1450/1250
Height with insulation/ with no insulation	mm	2205 / 2140	2185 / 2120	2470 / 2425	2680 / 2650
Insulation thickness	mm	100	100	100	100
First magnesium anode (∅ × length)	mm	32 × 700	32 × 700	32 × 700	32 × 700
Second magnesium anode (∅ × length)	mm	-	32 × 400	32 × 700	32 × 700
External / internal flange diameter	mm	290 / 220	290 / 220	290 / 220	290 / 220
Diameter/length of sensor-holder pockets	mm	8 / 200	8 / 200	8 / 200	8 / 200
Sleeve for heating element (not supplied)	∅	1"1/2	1"1/2	1"1/2	1"1/2
Maximum operating temperature	°C	99	99	99	99
Maximum operating pressure	bar	10	8	8	8
Heat dissipation (UNI EN 12897/06) ΔT = 45 K	W (W/K)	142 (3.2)	162 (3.6)	186 (4.1)	344 (7.6)
Energy class		C	C	C	-
Net weight with insulation	kg	190	305	425	543

## Technical data of coils (accessories)

Description	Unit	Code 20055205	Code 4383089	Code 4383087
Heat exchanger surface	m <sup>2</sup>	2.63	4.54	6.34
Nominal power P <sub>max</sub>	kW	53	91	127
Flow rate required Q <sub>max</sub> by the coil (con P <sub>max</sub> and T = 80/60 °C)	m <sup>3</sup> /h	2.3	3.9	5.5
Production of domestic hot water ΔT = 35 K	m <sup>3</sup> /h	1.3	2.2	3.1
Tube diameter	mm	18 × 1	18 × 1	18 × 1
Number of tubes	n	1	2	2
Pressure drop with Q <sub>max</sub>	mbar	748	720	2017
Weight	kg	14.9	22.6	29.0
Water content	l	1.74	3.56	5.1

Vbu (\*) The non-solar useful volume expresses the amount of water (in litres) heated directly by the thermal integration coil. It is calculated as the volume between the upper part of the cylinder and the lower part of the thermal integration element (lower turn of the integration coil). The value expressed in the table refers to the coil located in the central part of the storage tank. You can change the position of this coil and the volume will change accordingly.

Vsol (\*\*) The usable solar volume indicates the quantity of water (in litres) heated directly by the solar coil (placed in the lower part of the cylinder) minus the non-solar volume (Vbu).

## Coil pressure losses

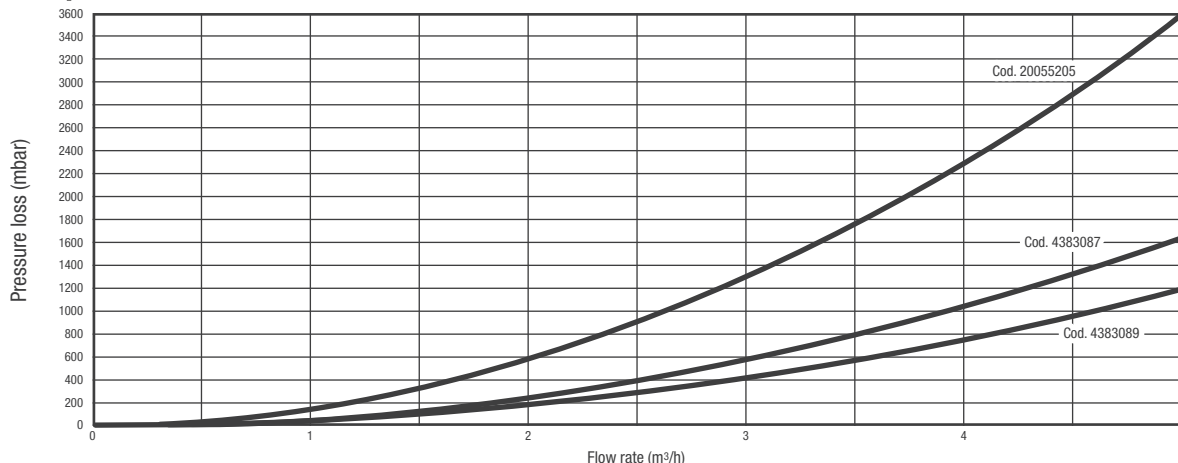

**Flanged solar cylinders IDRA PLUS DS 1000 - 1500 - 2000 - 3000**

# Structure

- 1. Cylinder
- 2. Electronic anode/sensor pocket (option)
- 3. Flange for inspection/insertion of additional heat exchangers
- 4. Sensor pocket
- 5. Thermometer connection
- 6. Insulation
- 7. Cover
- M Spring
- UAC Domestic hot water outlet
- EAF Domestic cold water inlet
- P Pocket
- SB Cylinder drain

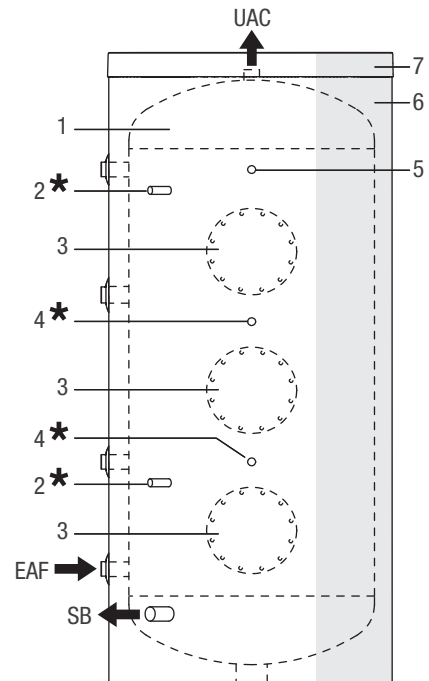
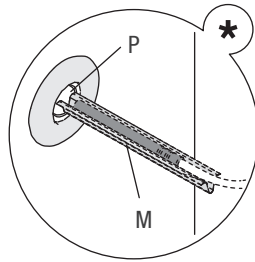

The IDRA PLUS DS solar cylinder is not equipped with load circulation pumps that must be suitably sized and installed on the system. For the recommended flow rate of the solar circuit, refer to the chapters on the solar collectors at the beginning of this document.

## Coil kit

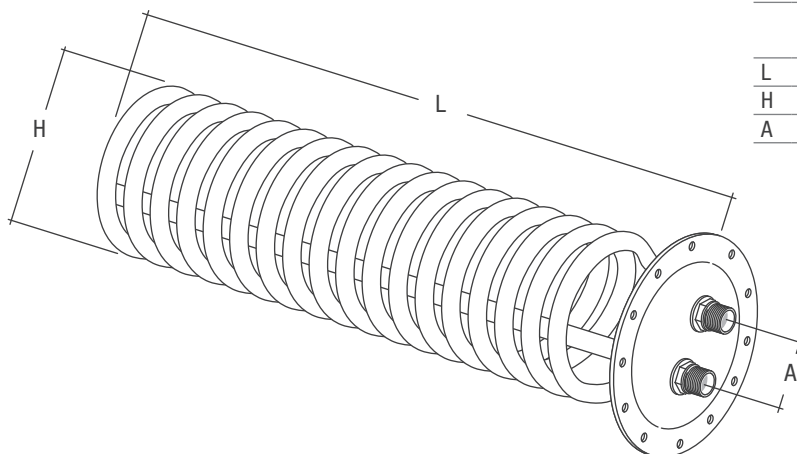

	Code 2005205	Code 4383089	Code 4383087
L	580 mm	750 mm	980 mm
H	DN 200	DN 200	DN 200
A	80 mm	80 mm	80 mm

Flanged solar cylinders IDRA PLUS DS 1000 - 1500 - 2000 - 3000

# Dimensions and couplings

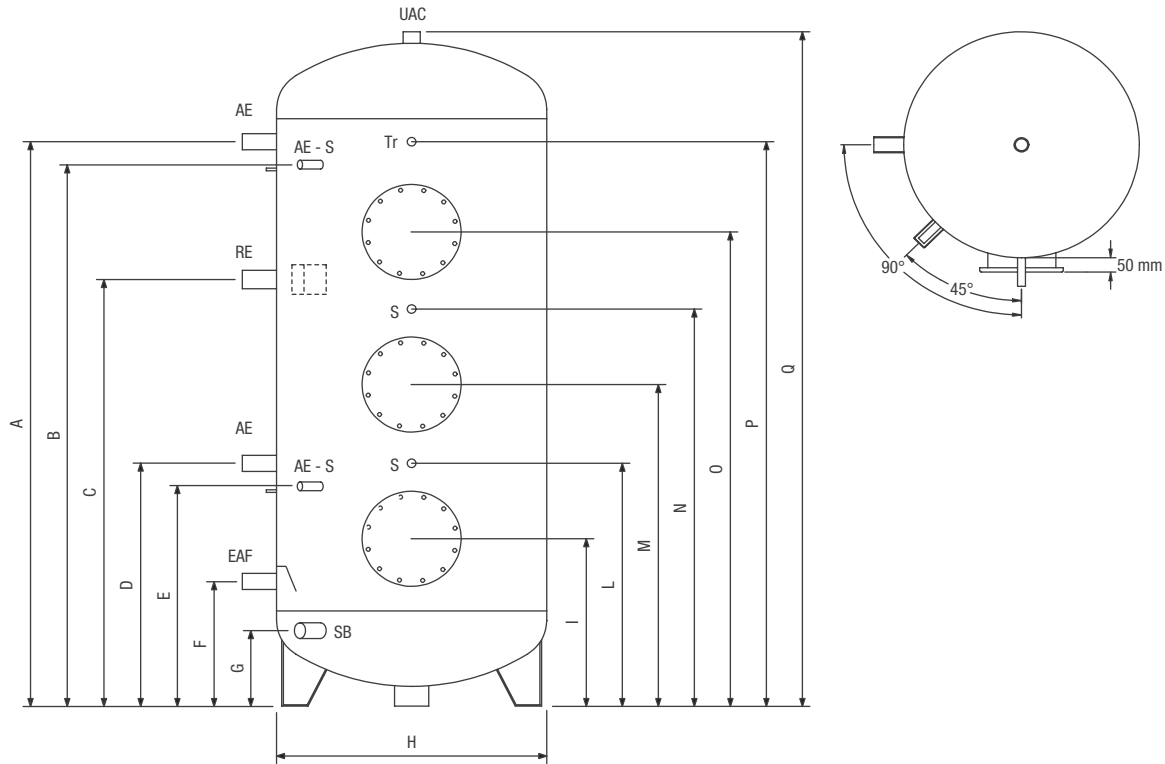

		IDRA PLUS DS 1000	IDRA PLUS DS 1500	IDRA PLUS DS 2000	IDRA PLUS DS 3000
UAC - Domestic hot water outlet	∅	1"1/2 F	1"1/2 F	2" F	2" F
EAF - Domestic cold water inlet	∅	1"1/2 F	1"1/2 F	2" F	2" F
SB - Cylinder drain	∅	1" F	1"1/4 F	1"1/4 F	1"1/4 F
AE - Magnesium anode	∅	1"1/4 F	1"1/4 F	1"1/4 F	1"1/4 F
AE - S - Diameter/length of pocket for sensors or electronic anode	mm	8 / 200	8 / 200	8 / 200	8 / 200
S - Diameter/length of the sensor-holder pocket	mm	8 / 200	8 / 200	8 / 200	8 / 200
Tr - Thermometer	∅	1/2" F	1/2" F	1/2" F	1/2" F
RE - Sleeve for heating element (not supplied)	∅	1"1/2 F	1"1/2 F	1"1/2 F	1"1/2 F
A	mm	1830	1720	1990	2265
B	mm	1760	1650	1920	2195
C	mm	1295	1250	1345	1455
D	mm	760	800	820	865
E	mm	690	730	750	795
F	mm	350	435	410	475
G	mm	240	280	250	190
H	mm	790	1000	1100	1250
I	mm	470	545	555	580
L	mm	-	760	820	865
M	mm	1075	1075	1085	1165
N	mm	1295	1290	1345	1455
O	mm	1610	1505	1670	1860
P	mm	1830	1720	1990	2265
Q	mm	2140	2120	2425	2700

# Single-coil cylinders IDRA C-HP MS

## Specification Guide

### Product description

Vertical steel quick storage heater, highly versatile, with single coil heat exchanger, high thermal insulation, internally glass-lined to ensure hygiene and make limescale removal easier.

ErP Ready - Energy Class B; the tank geometry and the elliptical cross-section of the heat exchanger provide excellent performance in terms of heat exchange (minimised heat loss) and fast recovery times.

Available in six sizes with different capacities, for maximum adaptability to different contexts, for use in systems for domestic hot water production.

The IDRA C-HP MS range provides excellent versatility as it can be combined with both boilers and heat pumps.

### Construction characteristics

- Vertical steel structure, internally glass-lined according to the Bayer Glaslining process in accordance with the DIN 4753 standard.
- Coil heat exchanger, with elliptical pipe cross-section, optimised to increase turbulence and heat exchange.
- Models: 150 (162 litres), 200 (207 litres), 300 (305 litres), 500 (500 litres), 800 (735 litres) and 1000 (890 litres).
- The carefully designed insulation minimises the internal convective effect, reduces heat loss and makes on-site installation easier. It is divided into:
  - closed-cell polyurethane foam, minimum thickness 50 mm, cfc-free, up to model 500;
  - self-supporting felt/polystyrene foam mix, easily assembled in 4 interlocking sections, with no need for straps (100 mm thick) for models 800 and 1000. This facilitates the passage of the heater through doors with a clear width of 800 mm.
- Energy Class B, declared losses according to EN 12897:2006 ( $\Delta T$  45 K, ambient 20°C and storage 65°C):
  - 55 W (model 150)
  - 58 W (model 200)
  - 68 W (model 300)
  - 84 W (model 500)
  - 95 W (model 800)
  - 103 W (model 1000)
- Embossed ABS cladding, colour RAL 9006.
- Carefully insulated heater inspection and cleaning flange to minimise heat loss. The flange can be replaced by a removable coil (accessory), to be connected to solar thermal system, for instance.
- Probe-holding pocket.
- Magnesium anode for protection against corrosion due to stray currents.
- Heater and coil maximum operating pressure: 10 bar (up to model 500) and 7 bar (models 800 and 1000).



### Compliance

IDRA C-HP MS heaters are compliant with the DIN 4753-3 and UNI EN 12897 standards.

## Single-coil cylinders IDRA C-HP MS

## Technical data sheet

Description	IDRA C-HP MS						
	150	200	300	500	800	1000	
Heater type	Vertical, Glass-lined						
Exchanger layout	Vertical, elliptic cross-section			Vertical, circular cross-section			
Heater capacity	l	170	210	305	500	735	890
Heater diameter, with insulation	mm	604	604	604	755	974	974
Heater diameter, without insulation	mm	-	-	-	-	790	790
Height with insulation	mm	1138	1354	1838	1793	1835	2155
Height without insulation	mm	-	-	-	-	1745	2070
Insulation thickness	mm	52	52	52	52	92	92
Overall net weight	kg	62	78	103	150	203	225
Quantity/diameter/length of the magnesium anode(s)	mm	1/33/300	1/33/450	1/33/480	1/40/600	1/40/600	1/40/750
Flange internal diameter	mm	130					
Diameter/length of probe-holding pockets	mm	2/16/180					
Coil water capacity	l	4.25	7,3	9	18.9	21	24.4
Coil exchange surface area	m <sup>2</sup>	0.85	1.38	1.7	2.2	2.5	2.9
Heater maximum operating pressure	bar	10	10	10	10	7	7
Coil maximum operating pressure	bar	10	10	10	10	7	7
Maximum operating temperature	°C	99					
Losses according to EN 12897:2006 $\Delta T = 45^{\circ}\text{C}$ (ambient @ 20°C and storage @ 65°C)	W	55	58	68	84	94	101
Losses according to UNI 11300	W/K	1.22	1.31	1.51	1.87	2.09	2.24
Energy class		B	B	B	B	B	B
<b>Continuous domestic water yield (DHW 10-45°C) at various coil inlet temperatures and with the indicated delta (<math>\Delta</math>) T°.</b>							
Coil delivery temperature							
80°C $\Delta T$ 20°C	kW	27	39	49	57	69	75
	l/h	660	950	1196	1406	1728	1860
70°C $\Delta T$ 20°C	kW	19	28	37	41	53	57
	l/h	480	690	921	1008	1300	1403
60°C $\Delta T$ 10°C	kW	11	17	23	30	37	39
	l/h	280	410	530	734	910	960
50°C $\Delta T$ 10°C	kW	8	9	13	16.3	19	25.3
	l/h	197	220	319	401	460	622
<b>Start-up time required to warm up the heater to 60°C (coil probe point reference) with the primary at the delivery temperature and with the indicated delta (<math>\Delta</math>) T°.</b>							
Coil delivery temperature							
80°C $\Delta T$ 20°C	min	35	34	38	35	50	52
70°C $\Delta T$ 20°C	min	39	40	47	45	74	77
<b>Start-up time required to warm up the heater to 55°C (coil probe point reference) with the primary at the delivery temperature and with the indicated delta (<math>\Delta</math>) T°.</b>							
Coil delivery temperature							
60°C $\Delta T$ 10°C	min	45	43	50	51	76	82
<b>Start-up time required to warm up the heater to 45°C (coil probe point reference) with the primary at the delivery temperature and with the indicated delta (<math>\Delta</math>) T°.</b>							
Coil delivery temperature							
50°C $\Delta T$ 10°C	min	56	53	55	59	80	94

## Single-coil cylinders IDRA C-HP MS

Description	IDRA C-HP MS						
	150	200	300	500	800	1000	
<b>Heat yield coefficient NL according to DIN 4708. The NL index expresses a number of flats with 3.5 persons that can be fully supplied, with a 140 L bathtub and two additional collection points.</b>							
Coil delivery temperature							
80°C	1.84	2.6	3.28	4.5	5.9	6.83	
70°C	1.44	2.01	2.63	3.4	4.9	5.67	
60°C	1	1.36	1.81	2.3	3.7	4.23	
50°C	0.75	0.86	1.26	1.7	2.37	2.68	
<b>Amount of domestic hot water obtained in 10', with heater preheated to 60°C (coil probe point reference), with the primary at the indicated delivery temperature, considering a domestic hot water temperature increase equal to 30°C, between the inlet and outlet (according to EN 12897).</b>							
Coil delivery temperature							
80°C	I	272	347	440	755	1270	1583
70°C	I	250	320	410	660	1177	1445
<b>Amount of domestic hot water obtained in 10', with heater preheated to 55°C (coil probe point reference), with the primary at the indicated delivery temperature, considering a domestic hot water temperature increase equal to 30°C, between the inlet and outlet (according to EN 12897).</b>							
Coil delivery temperature							
60°C	I	223	265	370	614	975	1163
<b>Amount of domestic hot water obtained in 10', with heater preheated to 45°C (coil probe point reference), with the primary at the indicated delivery temperature, considering a domestic hot water temperature increase equal to 30°C, between the inlet and outlet (according to EN 12897).</b>							
Coil delivery temperature							
50°C	I	170	208	305	510	720	812
<b>Nominal power accompanying heat pump A7/W60</b>							
	kW	6	8	12	16	18	26
<b>Continuous supply hot water (DHW 10-45°C) at various coil inlet temperatures and with the indicated delta (Δ) T°.</b>							
Coil delivery temperature							
50°C DT 5°C	kW	6,3	8,8	12,4	15,8	18,5	24,9
	l/h	155	213	305	388	450	612
<b>Start-up time required to heat the cylinder to 52°C (coil probe point reference) with the primary at the indicated delivery temperature and delta (Δ) T°.</b>							
Coil delivery temperature							
60°C DT 5°C (cylinder starting temperature 15°C)	h:mm	00:58	01:02	01:33	01:42	01:58	01:52
60°C DT 5°C (cylinder starting temperature 37°C)	h:mm	00:28	00:35	00:43	00:48	00:51	00:50
<b>Quantity hot water achieved in 10', with cylinder pre-heated to 52°C (coil probe point reference), with the primary at the indicated delivery temperature, considering a domestic hot water temperature increase equal to 30°C, between the inlet and outlet (according to EN 12897)</b>							
Coil delivery temperature							
60°C ΔT 5°C	I	223	265	370	613	980	1160
<b>Start-up time required to heat the cylinder to 55°C (coil probe point reference) with the primary at the indicated delivery temperature and delta (Δ) T°.</b>							
Coil delivery temperature							
60°C DT 5°C (cylinder starting temperature 15°C)	h:mm	01:23	01:27	01:58	02:14	02:23	02:17
60°C DT 5°C (cylinder starting temperature 37°C)	h:mm	00:45	00:52	01:00	01:05	01:08	01:07
<b>Quantity hot water achieved in 10', with cylinder pre-heated to 55°C (coil probe point reference), with the primary at the indicated delivery temperature, considering a domestic hot water temperature increase equal to 30°C, between the inlet and outlet (according to EN 12897)</b>							
Coil delivery temperature							
60°C ΔT 5°C	I	234	278	388	643	1029	1218

## Single-coil cylinders IDRA C-HP MS

Description	IDRA C-HP MS						
		150	200	300	500	800	1000
Nominal power accompanying heat pump A7/W75	kW	6	8	12	14	14	14
<b>Continuous supply hot water (DHW 10-45°C) at various coil inlet temperatures and with the indicated delta (<math>\Delta</math>) T°.</b>							
Coil delivery temperature							
75°C DT 5°C	kW	7,4	10,36	14,6	16	16	16
	l/h	182	251	360	393	393	393
<b>Start-up time required to heat the cylinder to 55°C (coil probe point reference) with the primary at the indicated delivery temperature and delta (<math>\Delta</math>) T°.</b>							
Coil delivery temperature							
75°C DT 5°C (cylinder starting temperature 15°C)	h:mm	00:55	00:57	01:18	01:28	02:20	02:55
75°C DT 5°C (cylinder starting temperature 37°C)	h:mm	00:28	00:32	00:37	00:40	01:04	01:20
<b>Quantity hot water achieved in 10', with cylinder pre-heated to 55°C (coil probe point reference), with the primary at the indicated delivery temperature, considering a domestic hot water temperature increase equal to 30°C, between the inlet and outlet (according to EN 12897)</b>							
Coil delivery temperature							
75°C $\Delta$ T 5°C	l	237	281	393	651	1042	1233
<b>Start-up time required to heat the boiler to 65°C (coil probe point reference) with the primary at the indicated delivery temperature and delta (<math>\Delta</math>) T°.</b>							
Coil delivery temperature							
75°C DT 5°C (cylinder starting temperature 15°C)	h:mm	01:26	01:35	01:52	02:45	04:45	05:30
75°C DT 5°C (cylinder starting temperature 37°C)	h:mm	00:48	00:52	01:05	01:32	02:28	03:05
<b>Quantity hot water achieved in 10', with cylinder pre-heated to 65°C (coil probe point reference), with the primary at the indicated delivery temperature, considering a domestic hot water temperature increase equal to 30°C, between the inlet and outlet (according to EN 12897)</b>							
Coil delivery temperature							
75°C $\Delta$ T 5°C	l	250	333	500	834	1334	1668
<b>Start-up time required to heat the cylinder to 70°C (coil probe point reference) with the primary at the indicated delivery temperature and delta (<math>\Delta</math>) T°.</b>							
Coil delivery temperature							
75°C DT 5°C (cylinder starting temperature 15°C)	h:mm	01:40	01:56	02:14	03:10	05:04	06:20
75°C DT 5°C (cylinder starting temperature 37°C)	h:mm	01:06	01:10	01:27	02:05	03:21	04:11
<b>Quantity hot water achieved in 10', with cylinder pre-heated to 70°C (coil probe point reference), with the primary at the indicated delivery temperature, considering a domestic hot water temperature increase equal to 30°C, between the inlet and outlet (according to EN 12897)</b>							
Coil delivery temperature							
75°C $\Delta$ T 5°C	l	273	364	546	911	1457	1822

### Single-coil cylinders IDRA C-HP MS

#### Coil load loss

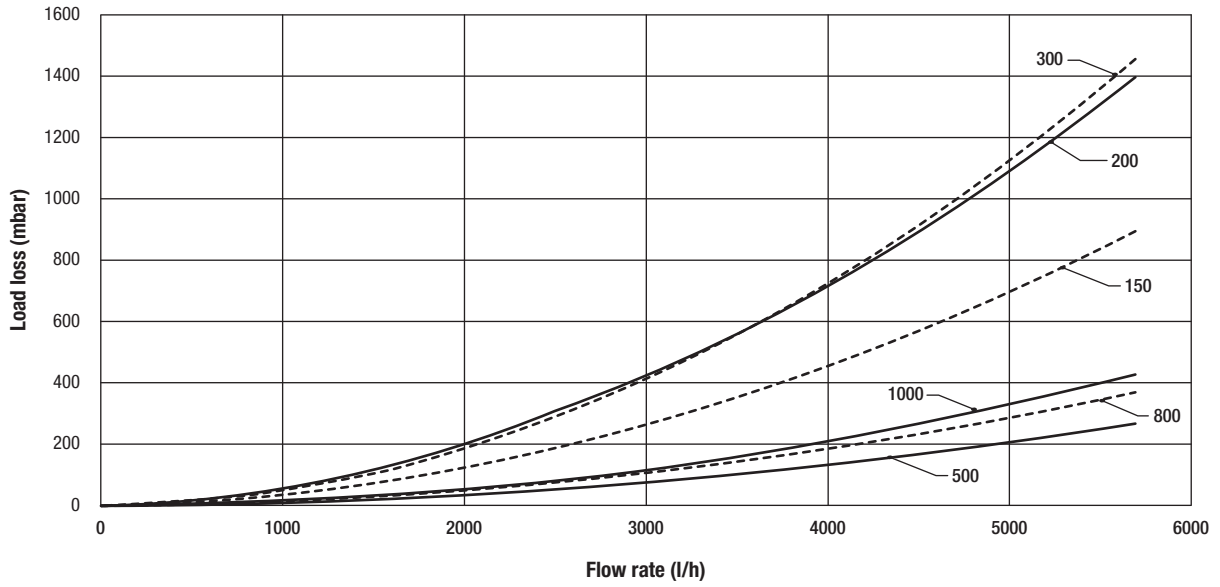

#### Structure

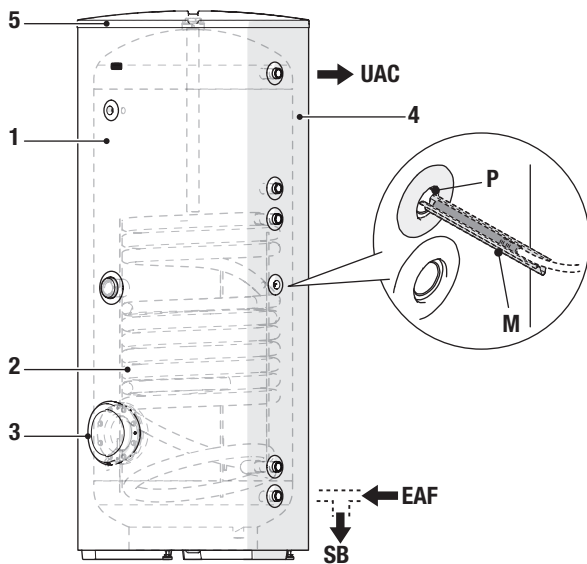

- 1. Heater
- 2. Coil
- 3. Heater inspection flange
- 4. Insulation
- 5. Cover
- P. Pocket
- M. Spring
- UAC. Domestic hot water outlet
- EAF. Domestic cold water inlet
- SB. Heater drain

Single-coil cylinders IDRA C-HP MS

# Hydraulic connections

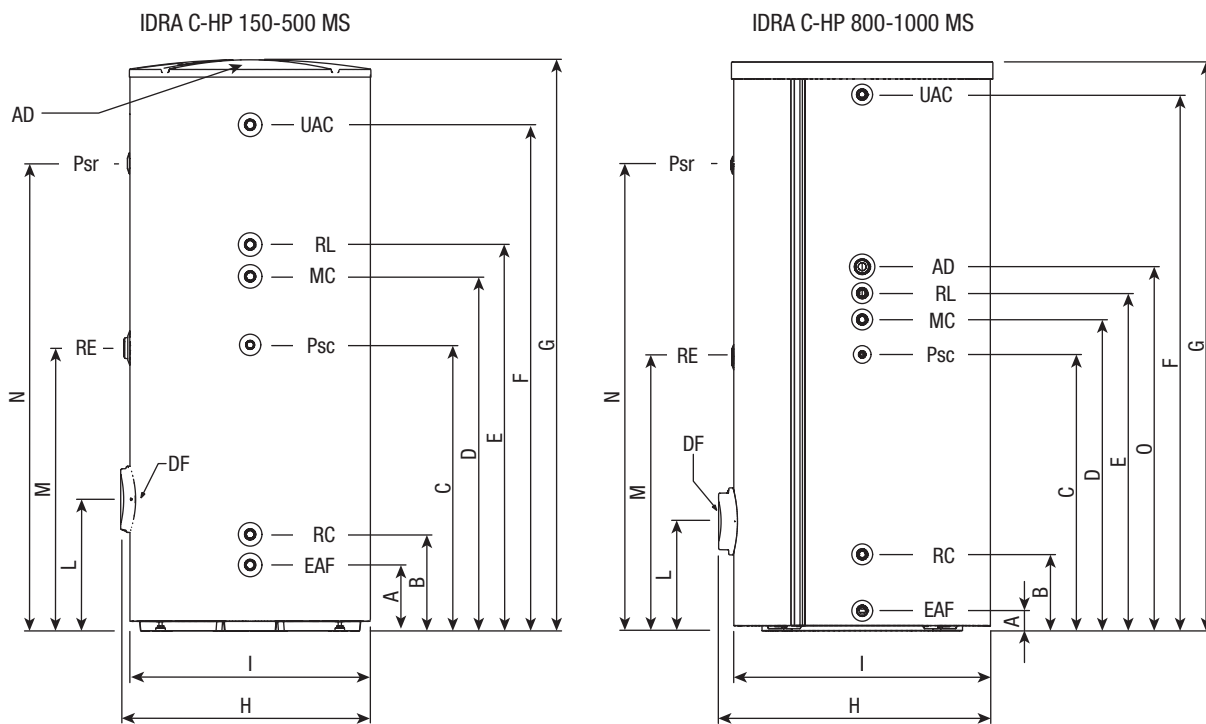

Description	IDRA C-HP MS					
	150	200	300	500	800	1000
Psr - Solar controller probe pocket diameter/length	mm			16/180		
RE - Sleeve for electrical resistor (not supplied)	∅			1" 1/2 F		
DF - Flange internal diameter	mm			130		
UAC - Domestic hot water outlet	∅		1" Gas M		1" 1/4 Gas M	
AD - Quantity/diameter/length of the magnesium anode(s)	mm	1/33/300	1/33/450	1/40/480	1/40/600	1/40/750
RL - Domestic water recirculation	∅			1" Gas M		
MC - Boiler-heat pump delivery	∅			1" Gas M		
Psc - Boiler-heat pump probe pocket internal diameter/length	mm			16/180		
RC - Boiler-heat pump return	∅			1" Gas M		
EAF - Domestic cold water inlet	∅		1" Gas M		1" 1/4 Gas M	
A	mm	171	174	174	207	75
B	mm	243	246	256	303	289
C	mm	588	673	928	898	1047
D	mm	753	956	1041	1113	1179
E	mm	836	1056	1141	1213	1279
F	mm	970	1189	1673	1589	2032
G	mm	1138	1354	1838	1793	2156
H	mm	626	630	634	786	1030
I	mm	604	604	604	755	974
L	mm	363	366	369	413	414
M (*)	mm	578	663	918	888	1037
N	mm	813	1066	1566	1468	1764
O	mm	-	-	-	-	1294

(\*) The connection (M) can be used as an alternative for the insertion of the first magnesium anode (in case of installation rooms that are not especially high).

## Single-coil cylinders IDRA C-HP MS

### Heater installation room

Beretta IDRA C-HP MS heaters can be installed in all rooms where no electrical protection rating of the device higher than IP X0D is required.

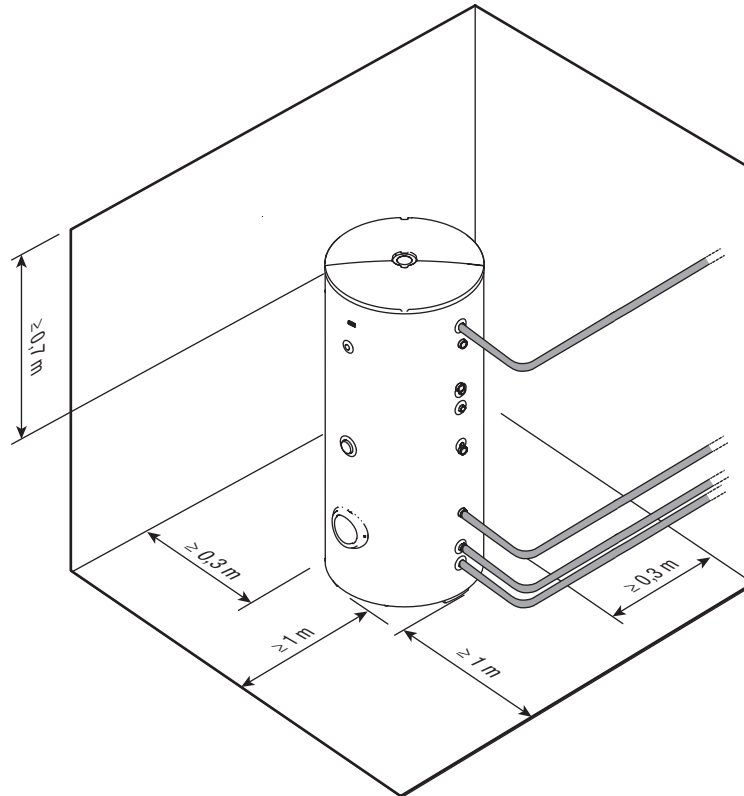

**NOTE** - the above steps are recommended for proper maintenance and accessibility of the unit.

### Installation on old systems or systems undergoing refurbishment

When the Beretta IDRA C-HP MS device is installed on old systems or systems undergoing refurbishment, verify that:

- The installation is equipped with safety and control devices compliant with the specific standards
- The system is flushed, free from sludge and scale, de-aerated and hydraulic seals have been checked
- A treatment system is provided when the feed/reintegration water is peculiar (the values listed in the table under “Water qualitative requirements” can be taken as reference values).

### Water qualitative requirements

REFERENCE VALUES	
pH	6-8
Electrical conductivity	less than 200 $\mu\text{S}/\text{cm}$ (25°C)
Chlorine ions	less than 50 ppm
Sulphuric acid ions	less than 50 ppm
Overall iron	less than 0.3 ppm
M Alkalinity	less than 50 ppm
Overall hardness	less than 35°F
Sulphur ions	none
Ammonia ions	none
Silicon ions	less than 30 ppm

The above values ensure proper operation of the system. Please refer to the limits given in the standards and regulations in force at the installation site.

### Single-coil cylinders IDRA C-HP MS

## Basic hydraulic circuit diagram

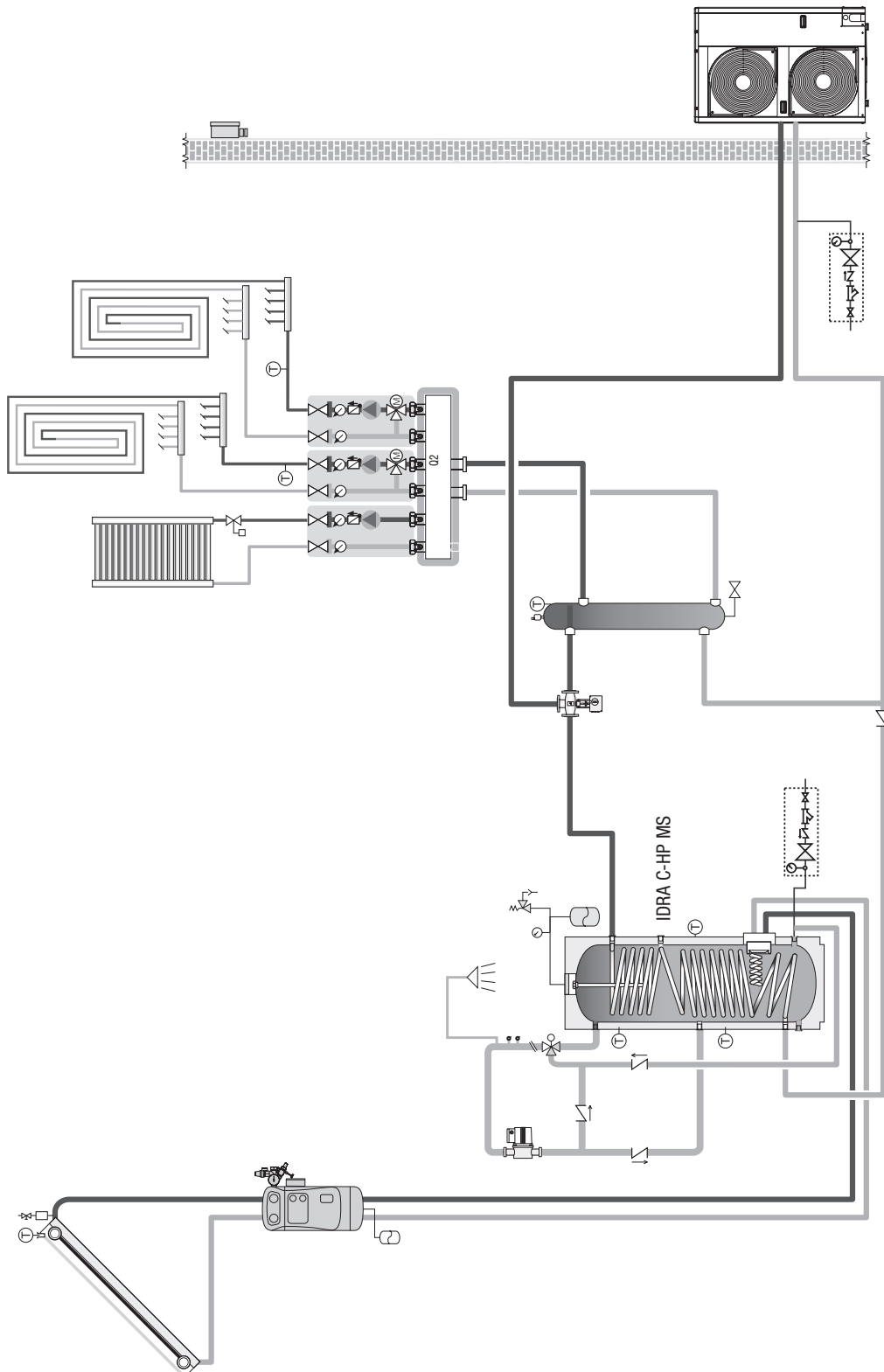

## Single-coil cylinders IDRA HP 300-500



**vertical buffer tank cylinder in glazed steel**  
**oversized coil for heat pump application**  
**flange for insertion of option solar coil kit**  
**maximum operating temperature 99°C**  
**maximum coil operating pressure 10 bar**  
**preset for electrical heating element**  
**magnesium anode as standard**  
**5-year warranty for cylinder**

The IDRA HP cylinders are designed for use on systems with heat pump, ensuring a high heat transfer thanks to a coil with a larger surface area.

Internally they are glazed for the production of domestic hot water (DHW), the external insulation is made of rigid polyurethane with a thickness of 50 mm.

It is possible to add an additional heat exchanger (option) to IDRA HP cylinders for possible integration with solar collectors.

They come complete with pockets, magnesium anode and the connection for the insertion of the electrical resistance (option).

## Single-coil cylinders IDRA HP 300-500

# Technical data sheet

Description	Unit	IDRA HP 300	IDRA HP 500
Cylinder type		Glazed	Glazed
Type of user		DHW production	DHW production
Cylinder layout		Vertical	Vertical
Exchanger layout		Vertical	Vertical
Coil surface area	m <sup>2</sup>	4	6
Max. cylinder pressure	bar	10	10
Coil content	l	23	51.5
Max. coil operating pressure	bar	10	10
Maximum operating temperature	°C	99	99
NL index		13	28
Heating water 60/50 °C	m <sup>3</sup> /h	1.6	2.7
Output 60/50 °C	kW	19	31
DHW production 10/45 °C (with heating water 60/50 °C)	m <sup>3</sup> /h	0.5	0.8
Heating water 80/60 °C	m <sup>3</sup> /h	4.1	6.7
Output 80/60 °C	kW	96	156
DHW production 10/45 °C (with heating water 80/60 °C)	m <sup>3</sup> /h	2.4	3.8
Insulation type		Polyurethane foam 50 mm thick - injected rigid CFC-free PU	
Inspection flange	mm	Ø 180/120	Ø 180/120
Weight	kg	119	166
Usable volume	l	263	475
Dissipation (with ambient temperature 20 °C and cylinder water at 60 °C)	W/K	2.1	2.8
Insulation class		C	C

## Accessories

Description	Unit	IDRA HP 300	IDRA HP 500
Heating element	kW	1.5	3.8
Heat exchanger for solar system	m <sup>2</sup>	0.8	1.2

### Single-coil cylinders IDRA HP 300-500

## Temperature loss

Calculation made considering the difference between the average temperature inside the boiler and the ambient temperature  $T = 20\text{ °C}$

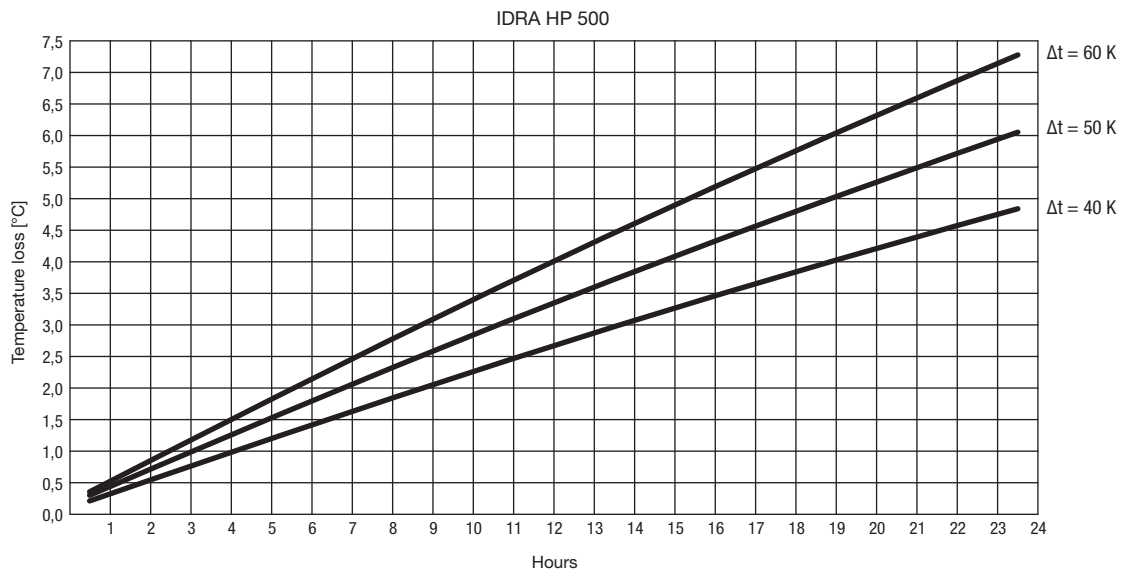
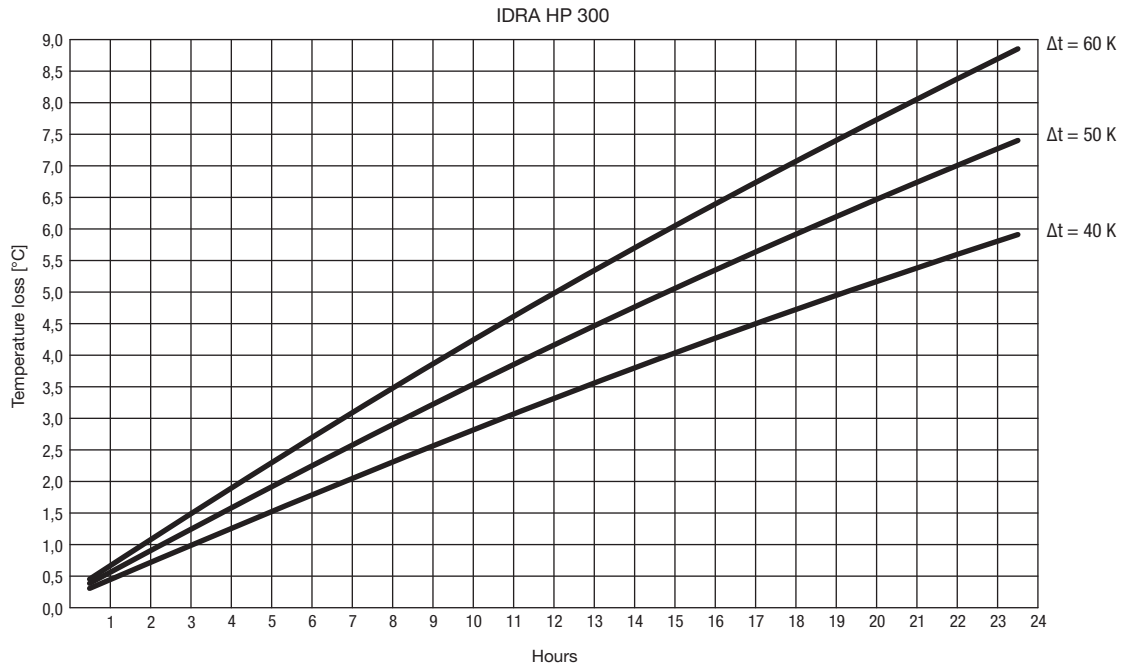

### Single-coil cylinders IDRA HP 300-500

## Coil pressure loss

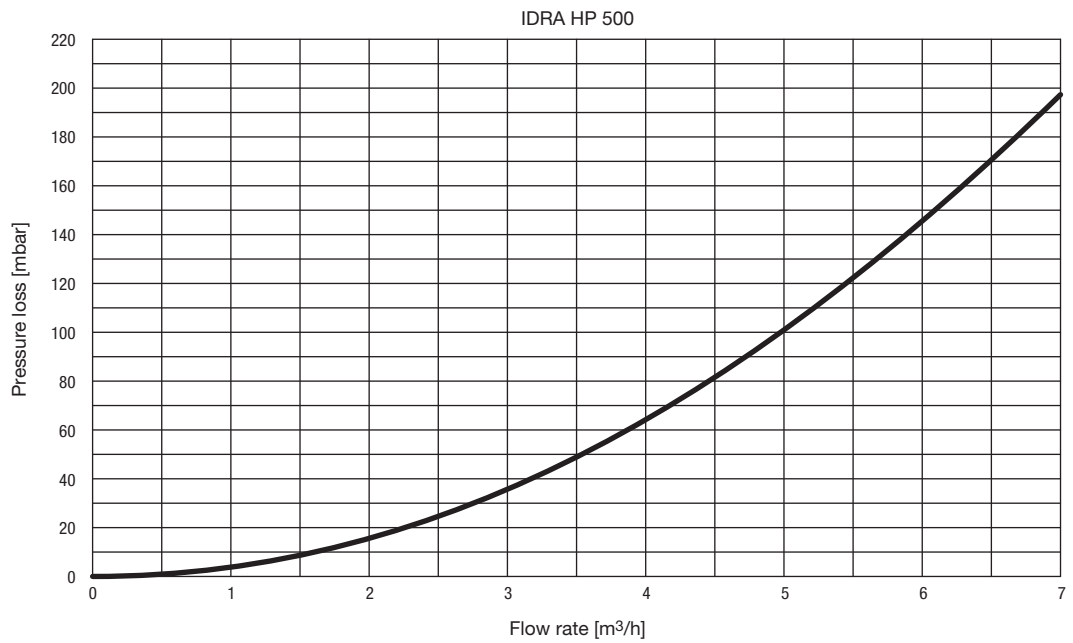
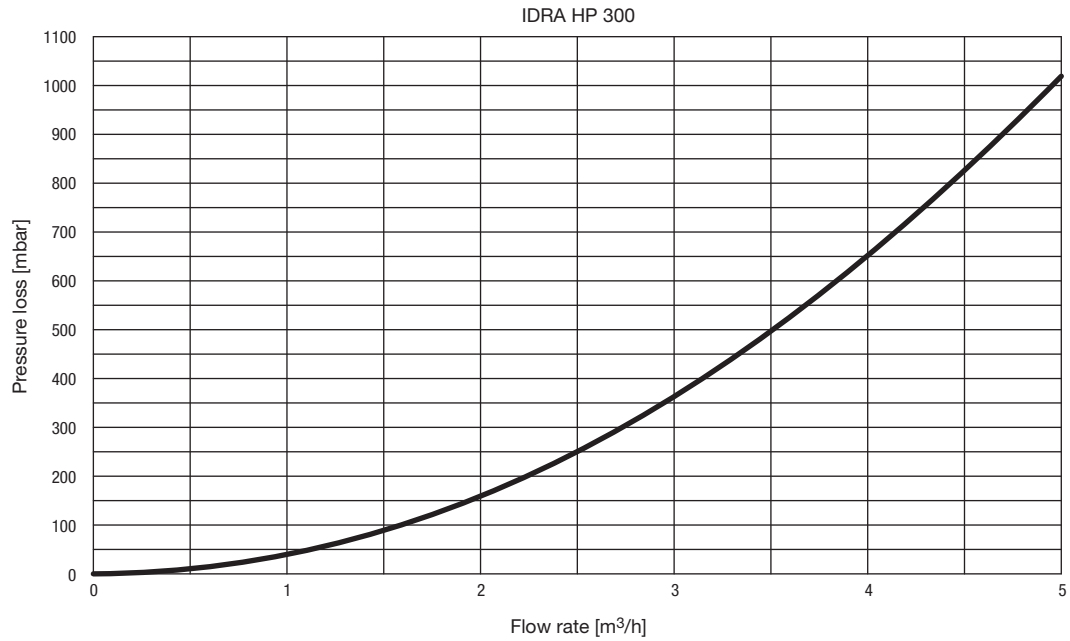

Single-coil cylinders IDRA HP 300-500

# Overall dimensions and couplings

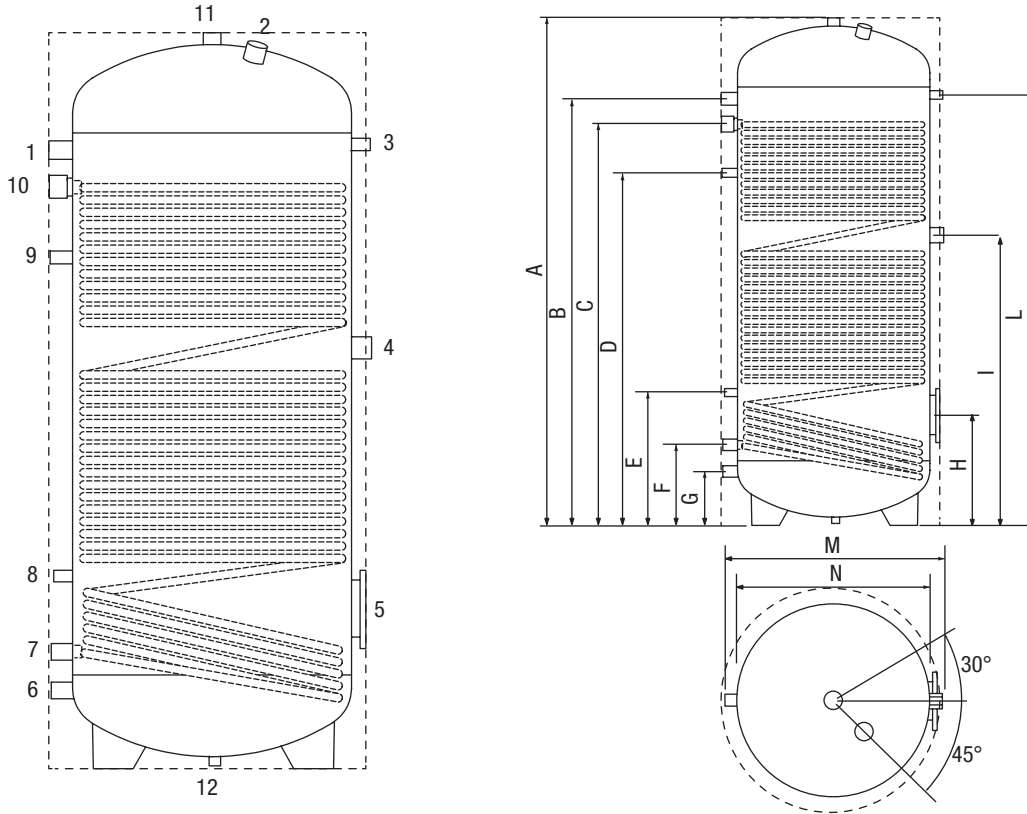

		IDRA HP 300	IDRA HP 500
1 - Hot water delivery line		1"	1"
2 - Anode		1"1/4	1"1/4
3 - Sensor thermometer		1/2"	1/2"
4 - Heating element		1"1/2	1"1/2
5 - Flange		Ø 180/120 mm	Ø 180/120 mm
6 - Cold water inlet/Drain		1"	1"
7 - Coil return		1"	1"1/4
8 - Sensor		1/2"	1/2"
9 - Recirculation		1/2"	1/2"
10 - Coil delivery line		1"	1"1/4
11 - Hot water delivery line		1"1/4	1"1/4
12 - Pallet fixture (blind)		1/2"	1/2"
A	mm	1615	1690
B	mm	1390	1415
C	mm	1310	1325
D	mm	1165	1170
E	mm	395	425
F	mm	220	265
G	mm	140	185
H	mm	340	370
I	mm	945	970
L	mm	1390	1425
M	mm	600	750
N	mm	500	650

Single-coil cylinders IDRA HP 300-500

# Basic hydraulic circuit diagram

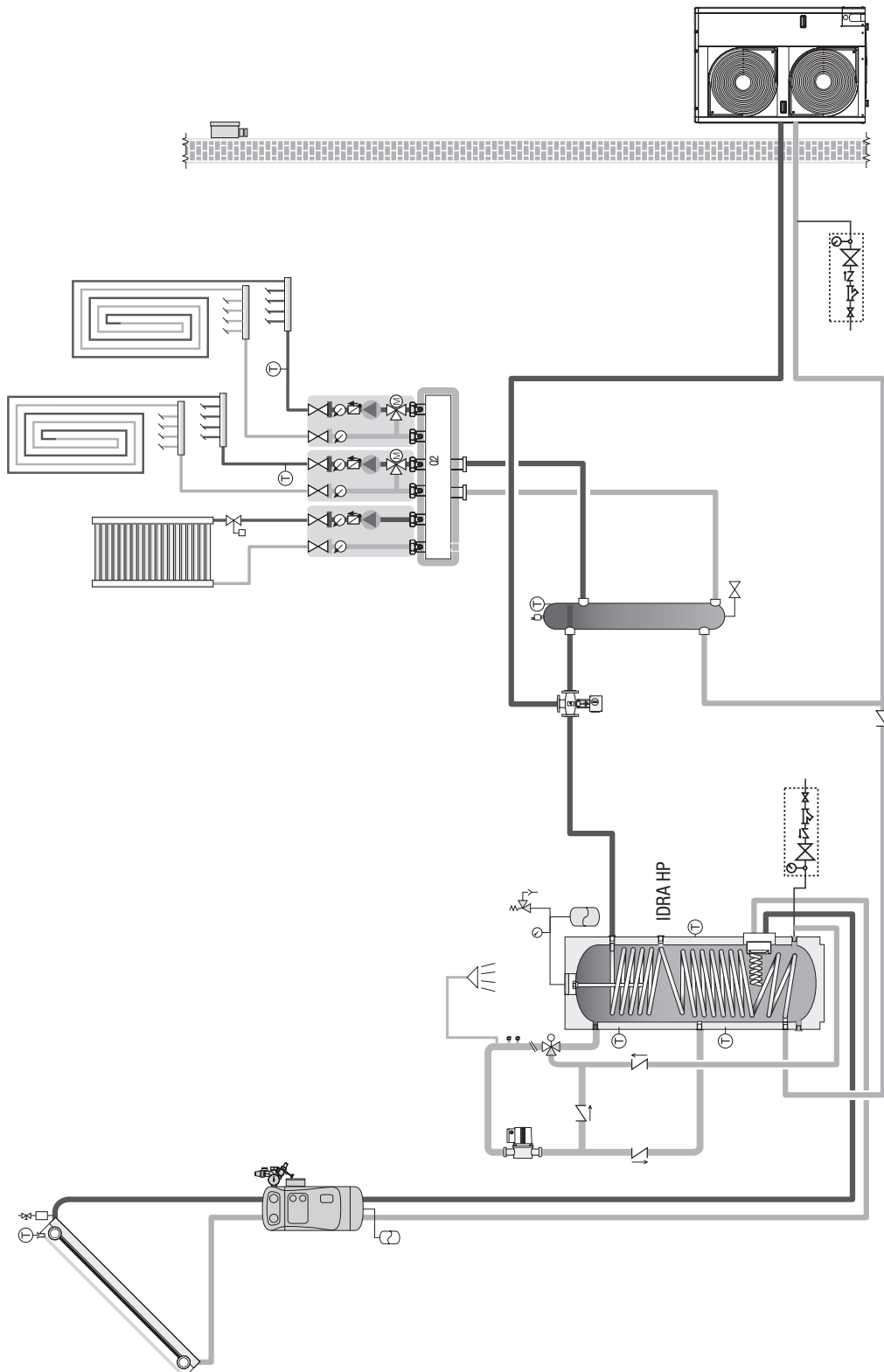

# Hot/cold inertial storage tanks

## STOR H 60 - 120 - 200 - 300 - 400 - 500



**thermal flywheel for heating and chilling**  
**suitable for heat pumps, solar systems, biomass**  
**possibility of integrating an electrical resistance**  
**effective thermal insulation and low pressure drop**  
**5-year warranty**

STOR H inertial storage tanks can be integrated into systems with chillers, solar collectors, heat pumps and wood-fired boilers. The storage tank allows different connection possibilities, thus guaranteeing system flexibility.

The main technical elements in the design of the storage unit are:

- The accurate study of tank geometries that allows to obtain the best performance in terms of stratification, heat exchange and recovery times.
- The arrangement of the connections on different heights to connect high and low temperature systems.
- CFC and HCFC-free polyurethane insulation and elegant outer covering to limit dissipation and therefore increase performance.

STOR H storage tanks can be easily integrated into systems in which Beretta boilers or thermal units are used as auxiliary heat generators.

Hot/cold inertial storage tanks STOR H 60 - 120 - 200 - 300 - 400 - 500

# Technical data sheet

Description	Unit	STOR H 60	STOR H 120	STOR H 200	STOR H 300	STOR H 400	STOR H 500
Type of storage		non-glazed	non-glazed	non-glazed	non-glazed	non-glazed	non-glazed
Storage layout		vertical	vertical	vertical	vertical	vertical	vertical
Usable volume	l	57	123	203	277	390	473
Outer diameter complete with insulation	mm	400	500	550	600	700	700
Full height of insulation	mm	935	1095	1395	1560	1540	1840
Insulation thickness	mm	50	50	50	50	50	50
Diameter of sensor-holder pockets		1/2"	1/2"	1/2"	1/2"	1/2"	1/2"
Maximum operating pressure for storage tank	bar	6	6	6	6	6	6
Maximum operating temperature for storage tank	°C	99	99	99	99	99	99
Energy efficiency class		B	B	C	C	C	C
Heat dissipation (UNI EN 12897/07) ΔT = 45K	W (W/K)	34 (0,75)	50 (1,11)	68 (1,5)	82 (1,8)	105 (2,3)	114 (2,5)
Net weight with insulation	kg	25	35	45	55	95	100

## Dimensions and couplings

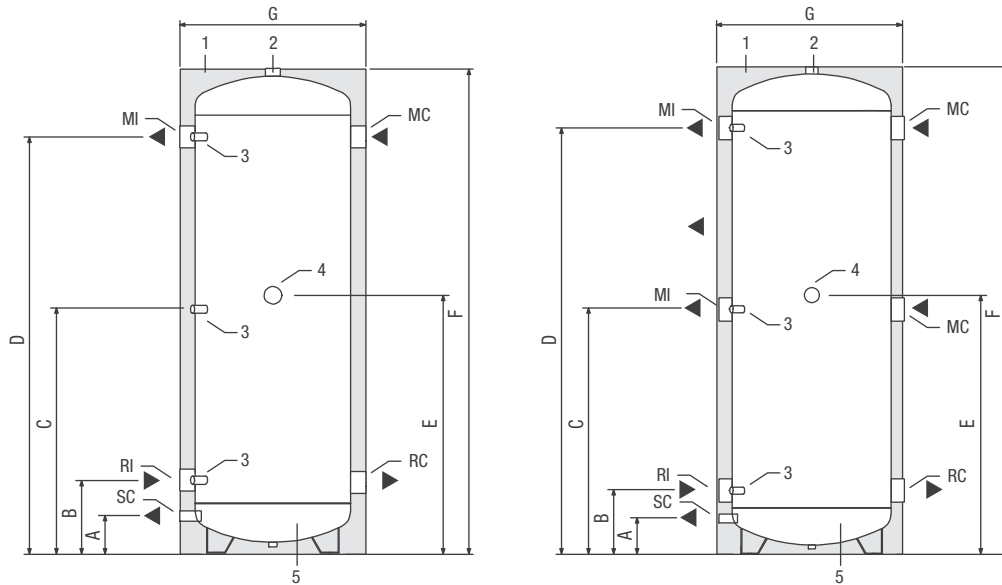

		STOR H 60	STOR H 120	STOR H 200	STOR H 300	STOR H 400	STOR H 500
1 - Polyurethane insulation	mm	50	50	50	50	50	50
2 - Vent connection	∅	1" F	1" F	1"1/4 F	1"1/4 F	1"1/4 F	1"1/4 F
3 - Sensor pockets	∅	1/2" F	1/2" F	1/2" F	1/2" F	1/2" F	1/2" F
4 - Electrical resistance connection (not supplied)	∅	1"1/2 F	1"1/2 F	1"1/2 F	1"1/2 F	1"1/2 F	1"1/2 F
5 - Storage		-	-	-	-	-	-
MI - System delivery line	∅	1"1/4 F	1"1/4 F	1"1/2 F	2" F	2"1/2 F	2"1/2 F
RI - System return line	∅	1"1/4 F	1"1/4 F	1"1/2 F	2" F	2"1/2 F	2"1/2 F
SC - Drain	∅	1/2" F	1/2" F	1/2" F	3/4" F	3/4" F	3/4" F
RC - Boiler return line	∅	1"1/4 F	1"1/4 F	1"1/2 F	2" F	2"1/2 F	2"1/2 F
MC - Boiler delivery line	∅	1"1/4 F	1"1/4 F	1"1/2 F	2" F	2"1/2 F	2"1/2 F
A	mm	100	100	105	120	135	135
B	mm	180	185	215	235	240	240
C	mm	485	560	705	785	775	925
D	mm	785	935	1200	1340	1310	1610
E	mm	530	605	750	830	820	970
F - Height	mm	935	1095	1395	1560	1540	1840
G - Diameter	mm	400	500	550	600	700	700
Net weight	kg	25	35	45	55	95	95
Gross weight (net+packaging)	kg	30	40	64	75	116	118

It is recommended to install shut-off valves in the delivery and return lines.

Hot/cold inertial storage tanks STOR H 60 - 120 - 200 - 300 - 400 - 500

# Hydraulic system configuration

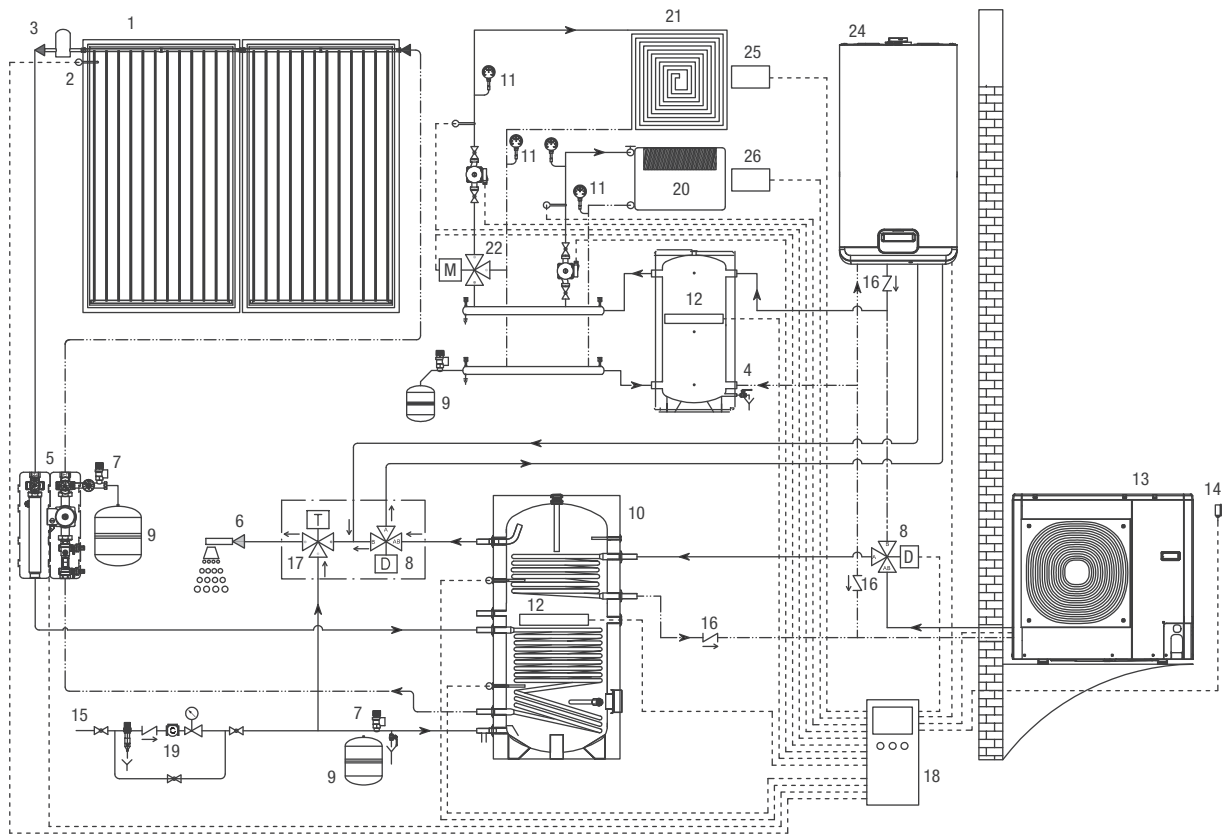

- |                                 |  |
|---------------------------------|--|
| 1. Solar collector              | 14. External sensor                            |
| 2. Collector sensor pocket      | 15. Mains water inlet                          |
| 3. Manual degasser (accessory)  | 16. Non-return valve                           |
| 4. STOR H inertial storage tank | 17. Thermostatic mixer                         |
| 5. Solar hydraulic unit         | 18. Energy manager                             |
| 6. Domestic hot water outlet    | 19. Safety unit                                |
| 7. Safety valve                 | 20. High-temperature system                    |
| 8. Diverting valve              | 21. Low-temperature system                     |
| 9. Expansion vessel             | 22. Mixing valve                               |
| 10. IDRA DS solar cylinder      | 23. Solar system loading and unloading valves  |
| 11. Thermometer                 | 24. Boiler                                     |
| 12. Heating element (option)    | 25. Low-temperature system ambient thermostat  |
| 13. Heat pump                   | 26. High-temperature system ambient thermostat |

# Inertial storage units STOR M 300-500-1000-1500 and STOR 2000-3000



**vertical inertial storage tank cylinder**  
**storage tank with coil heat exchanger (from 300 to 1500)**  
**ideal for solar systems**  
**effective thermal insulation and low pressure drop**  
**large heat exchange surface area of the coil**  
**easy access to the coil**

- The accurate study of tank and coil geometries (only for STOR M models) that allow to obtain the best performance in terms of stratification, heat exchange and recovery times.
- The arrangement of the connections at different heights to use different types of heat generators, without affecting the stratification.
- CFC-free polyurethane insulation and an elegant outer housing to limit heat loss and therefore increase performance.
- The use of the flange (only for STOR 2000-3000 models) facilitates cleaning and allows the insertion of an additional heat exchanger.
- Inertial storage tanks can be equipped with a specific solar regulator and can be easily integrated into solar systems in which boilers or thermal units are used as auxiliary heat generators.

**Inertial storage units STOR M 300-500-1000-1500 and STOR 2000-3000**

## Technical data sheets

Description	Unit	STOR M 300	STOR M 500	STOR M 1000	STOR M 1500
Type of storage		non-glazed	non-glazed	non-glazed	non-glazed
Storage layout		vertical	vertical	vertical	vertical
Exchanger layout		vertical	vertical	vertical	vertical
Storage capacity	l	270	476	920	1410
Diameter with/without insulation	mm	700 / -	850 / -	990 / 790	1200 / 1000
Height with/without insulation	mm	1635 / -	1775 / -	2190 / 2115	2165 / 2090
Insulation thickness	mm	100	100	100	100
Diameter of sensor-holder pockets	mm	8	8	8	8
Coil water content	l	10.4	10.4	14.6	21.6
Coil exchange surface	m <sup>2</sup>	1.8	1.8	2.6	3.8
Coil nominal power (*)	kW	43	45	68	99
Required flow rate of the coil (*)	m <sup>3</sup> /h	1.9	1.9	2.9	4.2
Maximum operating pressure for storage tank	bar	3	3	3	3
Maximum operating temperature for storage tank	°C	99	99	99	99
Maximum coil operating pressure	bar	6	6	6	6
Maximum operating temperature for coil	°C	99	99	110	110
Heat dissipation (UNI EN 12897/06) $\Delta T = 45K$	W (W/K)	93 (2.1)	126 (2.8)	143 (3.2)	167 (3.7)
Net weight with insulation	kg	115	140	180	245
Energy class		C	C	-	-

Description	Unit	STOR 2000	STOR 3000
Type of storage		non-glazed	non-glazed
Storage layout		vertical	vertical
Storage capacity	l	2010	2959
Diameter with/without insulation	mm	1300 / 1100	1450 / 1250
Height with/without insulation	mm	2480 / 2405	2720 / 2645
Insulation thickness	mm	100	100
Flange diameter (outer/inner)	mm	290 / 220	290 / 220
Diameter of sensor-holder pockets	mm	8	8
Maximum operating pressure for storage tank	bar	3	3
Maximum operating temperature for storage tank	°C	99	99
Heat dissipation (UNI EN 12897/06) $\Delta T = 45K$	W (W/K)	190 (4.2)	344 (7.6)
Net weight with insulation	kg	290	415

(\*) According to DIN 4708 with  $\Delta T = 20 K (80/60 \text{ } ^\circ\text{C})$  on the coil.

**Inertial storage units STOR M 300-500-1000-1500 and STOR 2000-3000**

# Pressure losses

## Coil pressure losses

(only for STOR 300 M - 500 M - 1000 M - 1500 M models)

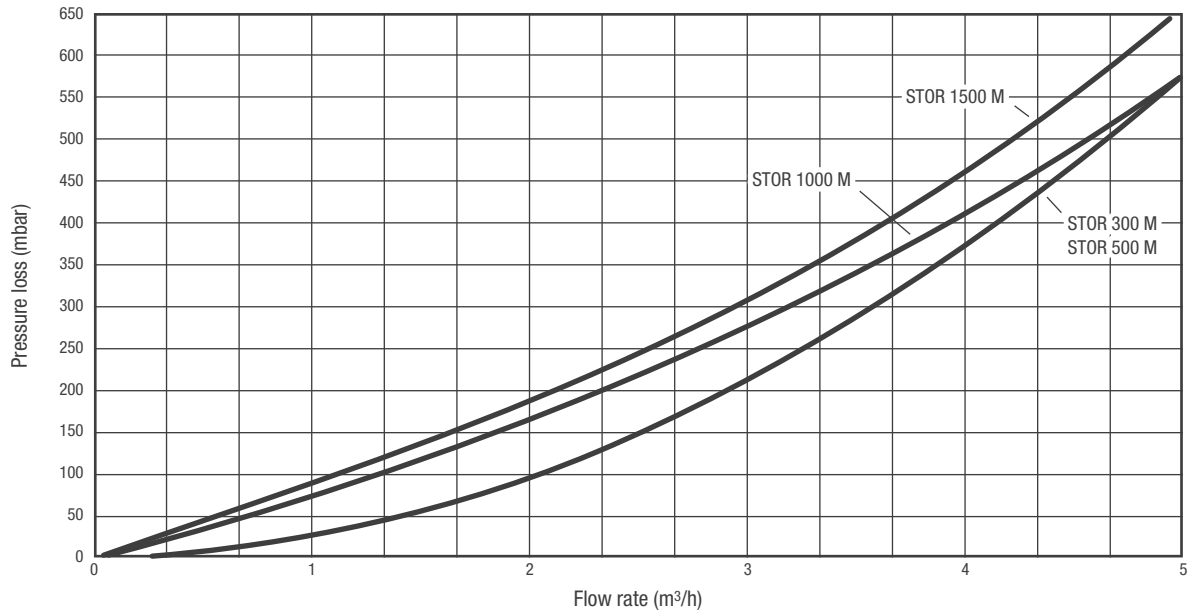

## Pressure losses of Heat exchanger coil kit (only for STOR 2000 - 3000 models)

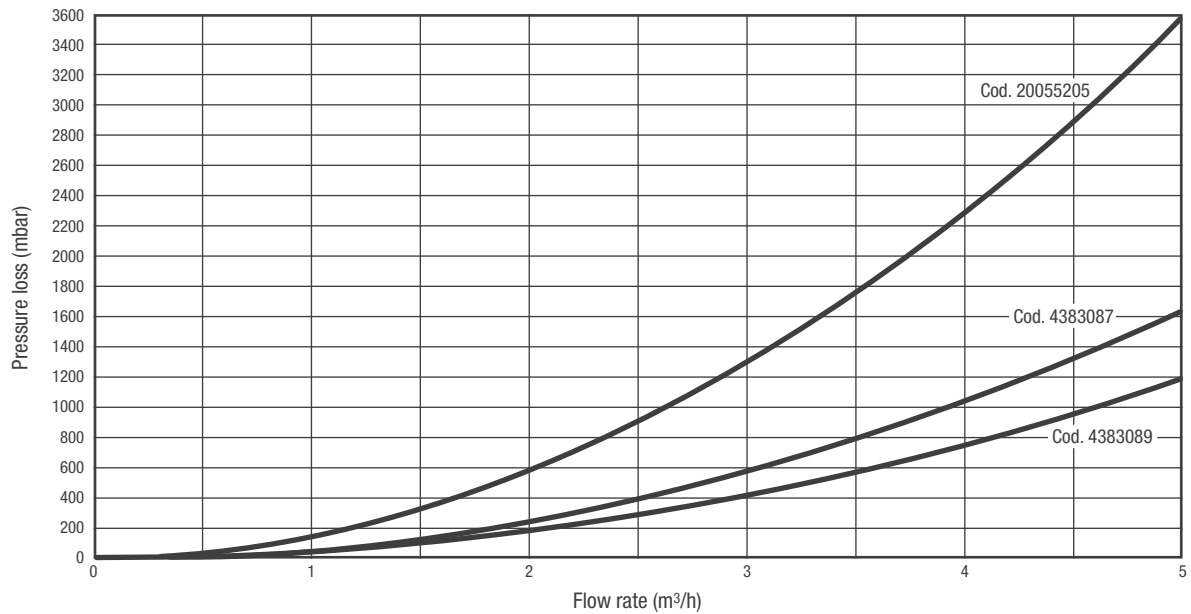

**Inertial storage units STOR M 300-500-1000-1500 and STOR 2000-3000**

# Hydraulic connection specifications

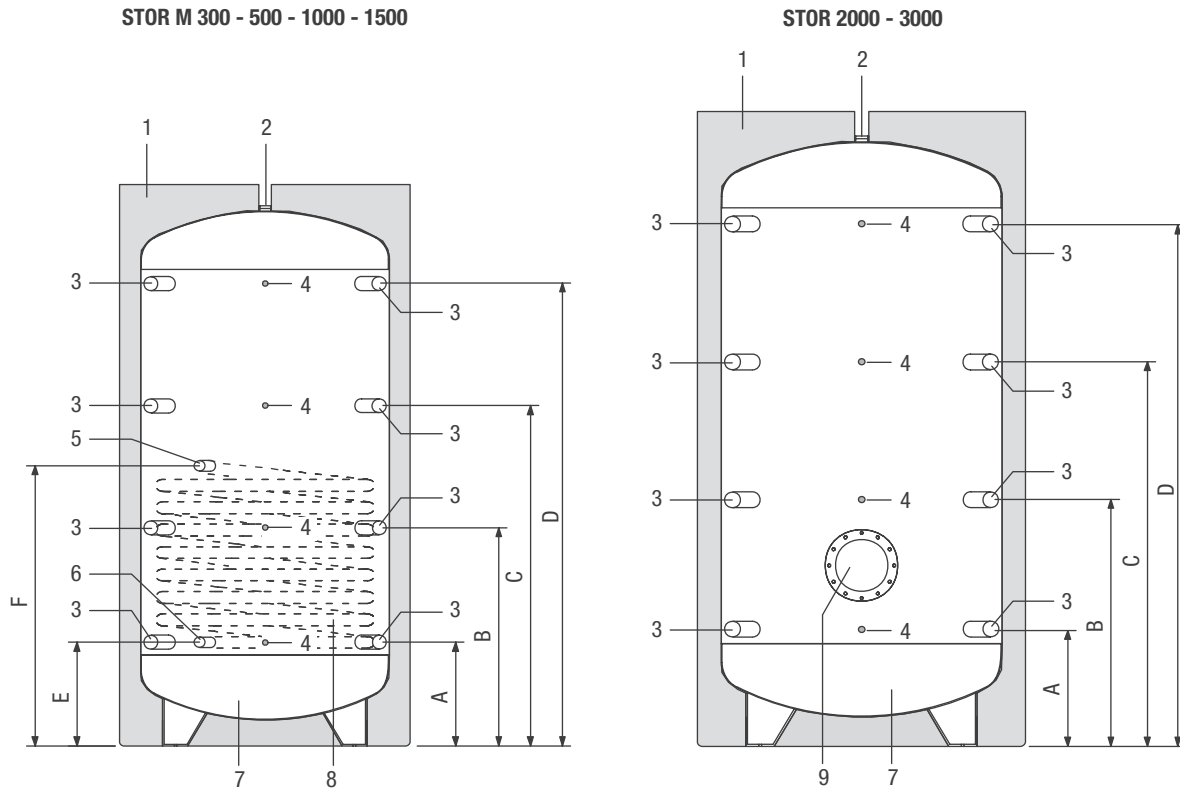

		STOR M 300	STOR M 500	STOR M 1000	STOR M 1500	STOR 2000	STOR 3000
1 - Insulation in soft polyurethane	mm	100	100	100	100	100	100
2 - Vent / delivery connection	∅	1" 1/4 F	1" 1/4 F	1" 1/4 F	1" 1/4 F	1" 1/4 F	1" 1/4 F
3 - Delivery/return connections	∅	1" 1/2 F	1" 1/2 F	1" 1/2 F	1" 1/2 F	1" 1/2 F	1" 1/2 F
4 - Sensor pockets	mm	8	8	8	8	8	8
5 - Collector delivery connection	∅	1" F	1" F	1" F	1" F	-	-
6 - Collector return connection	∅	1" F	1" F	1" F	1" F	-	-
7 - Tank							
8 - Coil						-	-
9 - Inspection flange		-	-	-	-		
A	mm	215	330	280	390	390	390
B	mm	595	710	805	850	950	1020
C	mm	975	1090	1335	1310	1510	1650
D	mm	1355	1470	1860	1770	2070	2280
E	mm	215	330	280	390	-	-
F	mm	815	930	990	1290	-	-

# Module for the production of domestic hot water

## SC ACS 25



- SC ACS 25 is an instant domestic hot water production module that uses a stainless steel brazed plate heat exchanger, which is widely used in combination with inertial storage systems.
- The domestic hot water temperature is controlled by thermostatic mixing of the primary circuit fluid.
- The circulation pump of the primary circuit is controlled by a flow switch located on the DHW line and electrically connected in series. There are two loading/unloading cocks that allow, by closing the shut-off valves, the heat exchanger flushing.
- For maximum comfort, a domestic hot water recirculation kit is available.
- SC ACS 25 is supplied complete with insulated frame.

## Technical data

Description	Unit	SC ACS 25
Absorbed heat output with storage system at 50°C and DHW withdrawal 10-45°C	kW	37
DHW withdrawal 10-45°C with storage at 50°C	l/min	15
Absorbed heat output with storage system at 55°C and DHW withdrawal 10-45°C	kW	46
DHW withdrawal 10-45°C with storage at 55°C	l/min	19
Absorbed heat output with storage system at 60°C and DHW withdrawal 10-40°C	kW	54
DHW withdrawal 10-40°C with storage at 60°C	l/min	26
Maximum output for primary side	l/h	1200
Minimum allowed temperature on the DHW side	°C	2
Maximum operating temperature	°C	90
Maximum operating pressure for primary side	bar	10
Primary non-return valve opening pressure	mbar	28
Secondary non-return valve opening pressure	mbar	28
Absorbed electrical power	W	45
Power supply voltage	V	230
Power supply frequency	Hz	50-60
Electrical protection level	IP	54
Net weight	kg	16.1
Water volume	l	5.2

Module for the production of domestic hot water SC ACS 25

# Structure

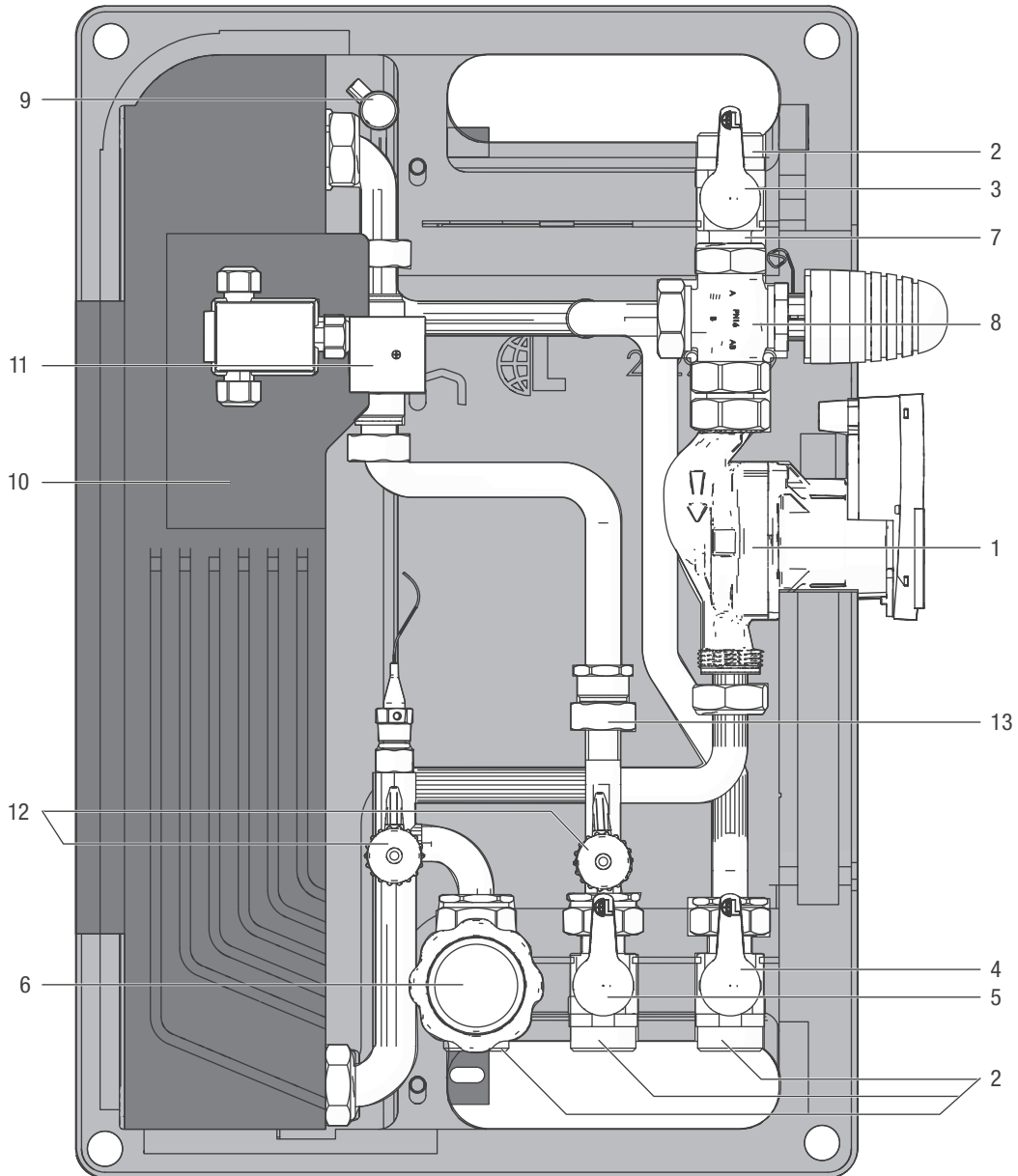

- |  |   |
|--|---|
| <ul style="list-style-type: none"> <li>1. Circulation pump</li> <li>2. Ball valve DN 20 1" M - 3/4"F</li> <li>3. Red handle - primary delivery valve</li> <li>4. Blue handle - primary return valve</li> <li>5. Blue handle - domestic cold water inlet valve</li> <li>6. Black handle - non-return valve with domestic hot water outlet thermometer</li> <li>7. Non-return valve</li> </ul> | <ul style="list-style-type: none"> <li>8. Three-way mixing valve with thermostatic actuator 35 - 65°C</li> <li>9. 3/8" manual bleeder valve</li> <li>10. Brazed stainless steel plate heat exchanger with insulation</li> <li>11. Flow switch</li> <li>12. 1/2" loading/unloading cock</li> <li>13. Fitting for connection of recirculation kit 3/4" F</li> </ul> |
|--|---|

Module for the production of domestic hot water SC ACS 25

## Dimensions and couplings

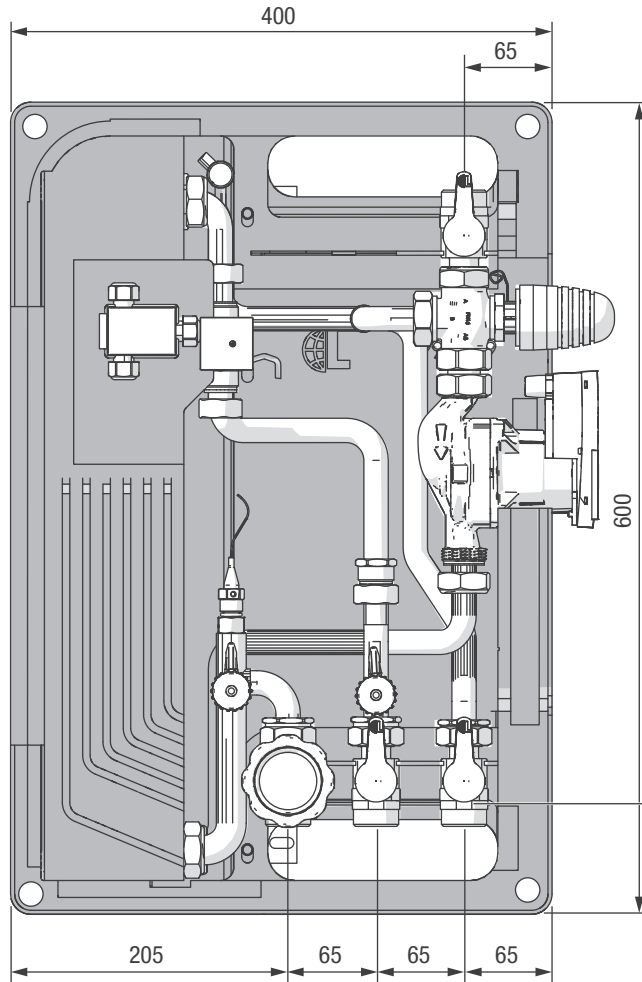

Description	SC ACS 25
Primary delivery line	1" M - 3/4" F
Primary outlet	1" M - 3/4" F
DCW circuit	1" M - 3/4" F
DHW outlet	1" M - 3/4" F
Recirculation	3/4" F
Depth (mm)	250

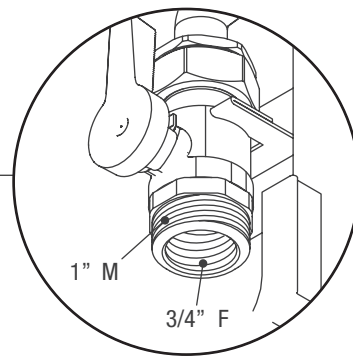

## Hydraulic circuit

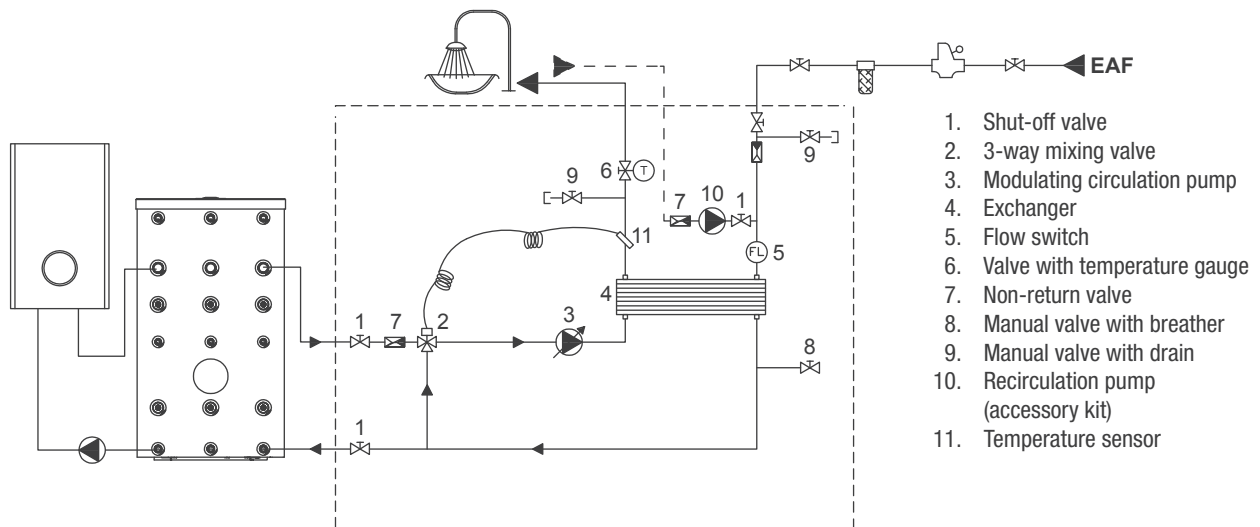

Module for the production of domestic hot water SC ACS 25

# Chart on production of DHW

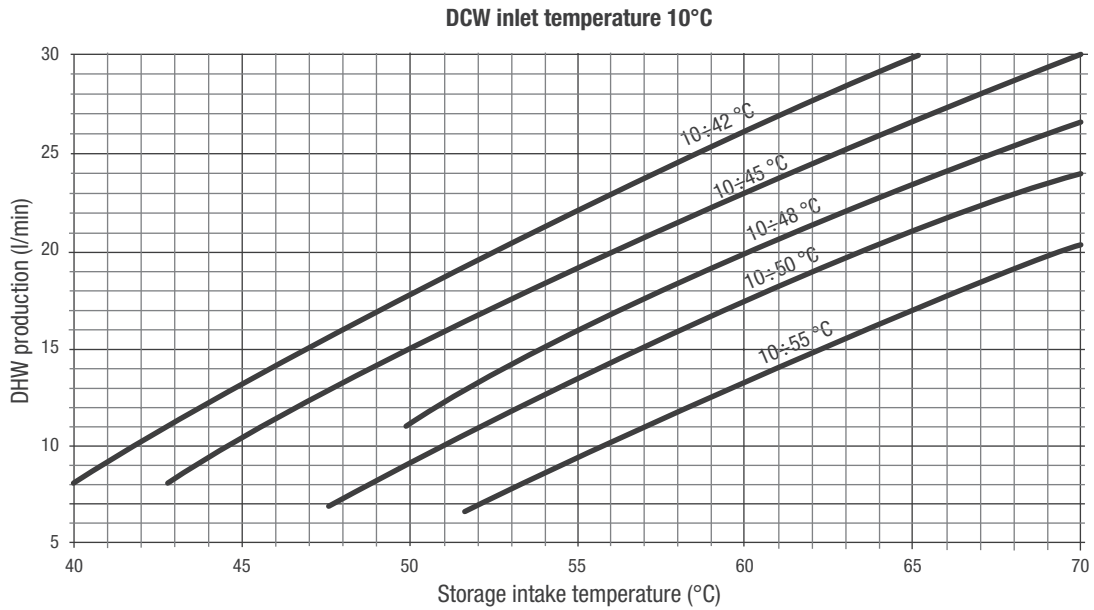

The correct operation of the module is guaranteed if the delivery temperature of the primary circuit is at least 5K higher than the set DHW temperature.

# DHW secondary circuit pressure loss

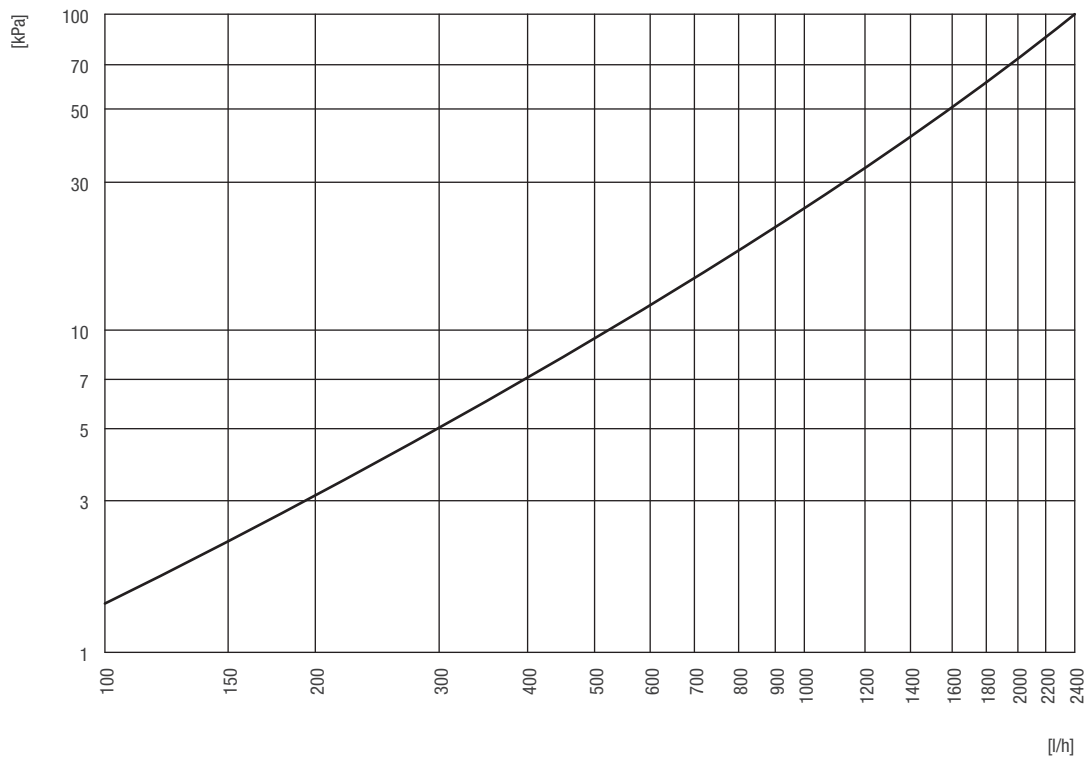

Module for the production of domestic hot water SC ACS 25

## Circulation pump curves

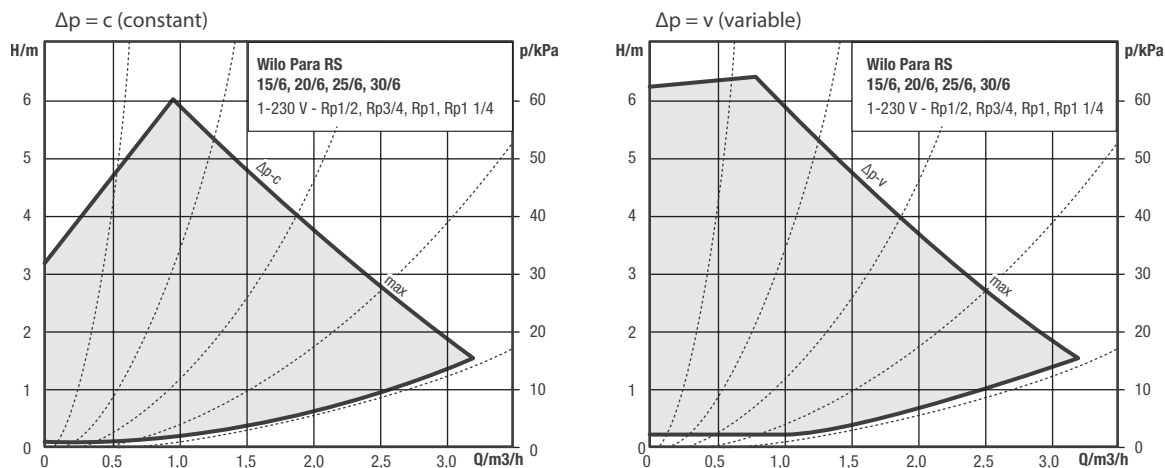

## Wiring diagram

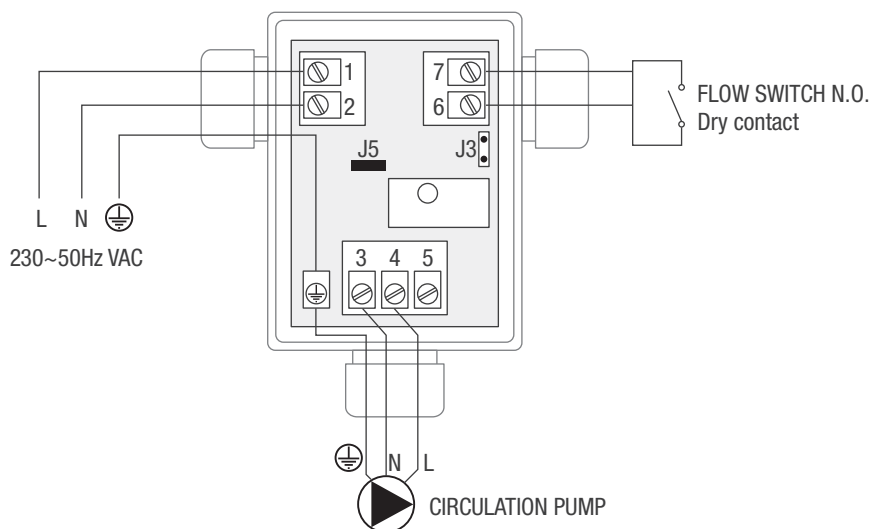

## Electrical wiring

It is mandatory:

- Have a differential magneto-thermal circuit breaker and a disconnecting switch compliant with the prevailing standards of the installation country.
- to comply with the connection L (phase) - N (Neutral); Ensure that the earth conductor is approx. 2 cm longer than power supply cables;
- Connect the device to an efficient earth system.

It is forbidden to use water pipes to earth the device.

It is forbidden to lay the power supply cables in the vicinity of any hot surfaces (delivery pipes). If there is a risk of contact with hot parts, with temperatures exceeding 50°C, a suitable type of cable must be utilized.

## Module for the production of domestic hot water SC ACS 25

### Commissioning

- Check tightness of connection nuts.
- Fill the system and check for any leaks.
- Slowly open the shut-off valves on both the drinking water and hot water sides to decrease pressure surges.
- Venting and bleeding the system:
  - Open a drinking water outlet with hot water distribution located near the system and unscrew the thermostat head as far as possible.
  - Venting on the storage tank side is done through the vent screw on the loading pump. Vent the system completely.
- Set the desired drinking water temperature on the thermostat head.
- Set the circulation unit to the function with constant pressure difference. This allows a constant head value to be maintained within the permitted flow rate range.
- Insert insulation.
- After commissioning, check the operation and tightness of the entire system.

Factory settings

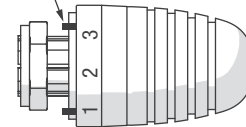

Pos. t	(*C)	
1	35	
2	40	
3	45	Factory settings
4	50	
5	55	Temperature limiter
6	60	
7	65	

### Hydraulic connection

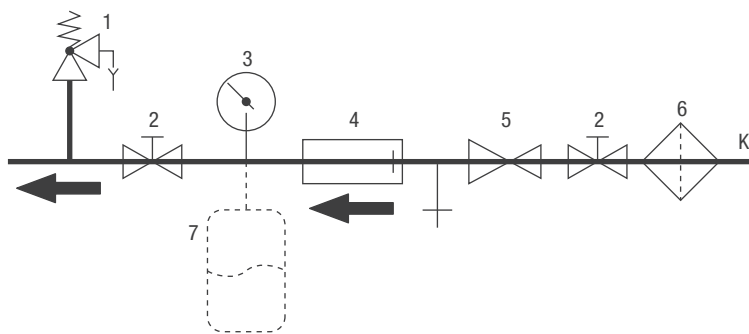

1. Safety valve
  2. Stop valve
  3. Pressure gauge
  4. Non-return device
  5. Pressure reducing valve (required with  $K \geq 6$  bar)
  6. Narrow mesh filter
  7. Expansion vessel (option)
- K Main drinking water connection

### Connection to the water mains

- For domestic hot water production systems, provide an impurity filter to protect the system. In addition, a check valve and an DCW inlet expansion vessel must be provided.
- In case of water with hardness higher than 25-30 °Fr, it is advisable to install an adequate water treatment system at the inlet of the heating system, in order to avoid possible scale build-up caused by hard water or corrosion due to aggressive water.
- It should be remembered that even a small build-up, just a few millimetres thick causes, because of its low thermal conductivity, a reduction in performance on the DHW side.
- The construction materials of the domestic hot water production module mod. SC ACS 25 comply with the provisions by the Ministerial Decree 174/2004, regulated by Directive 98/83/EC.
- Although the fittings are factory fitted, all screw connections must be checked and further tightened. It is also important to carry out a leak test (pressure test) during commissioning.
- Exceeding the values in the table on the side could result in damage to the DHW module and inevitably void the warranty, so we recommend a water analysis to show whether the values are within the limits indicated in the table.

Components	Units of measurement	Limit values for welded copper heat exchangers
PH		7-9 (considering the saturation index)
Saturation Index ( $\Delta$ PH)		-0.2 < 0 < +0.2
Total hardness	°Fr	15-30
Conductivity	$\mu$ S/cm	10... 500
Substances that can be filtered	mg/l	<30
Free chlorine	mg/l	<0.5
Hydrogen Sulphide	mg/l	<0.05
Ammonia	mg/l	<2
Hydrogen Carbonate	mg/l	<300
Hydrogen Carbonate/Sulphide	mg/l	>1.0
Sulphide	mg/l	<1
Nitrate	mg/l	<100
Nitrite	mg/l	<0.1
Sulphate	mg/l	<100
Manganese	mg/l	<0.1
Dissolved iron	mg/l	<0.2
Free aggressive carbon dioxide	mg/l	<20

Module for the production of domestic hot water SC ACS 25

### System diagram

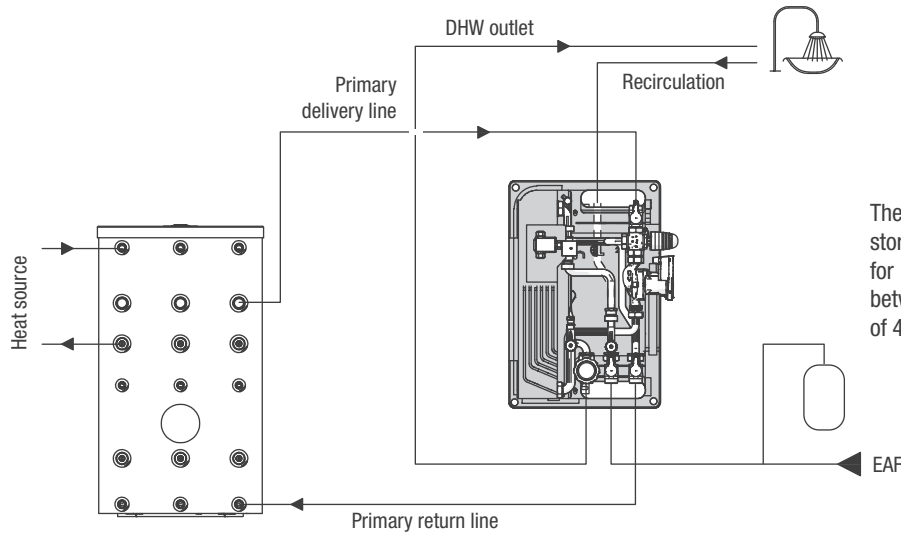

The module must be positioned near the storage tank. The system is dimensioned for a length of the connection pipes between the module and the storage tank of 4 meters (flow + return).

### DHW recirculation kit

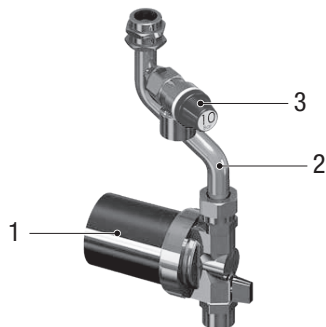

1. Circulation pump
2. Pipes with seals
3. Safety valve

Pumped fluid temperature	2 ÷ 65 °C
Max pressure	10 bar
Power supply	200-240 V
Frequency	50-60 Hz
Protection level	IP 44

### Circulation pump characteristics curves

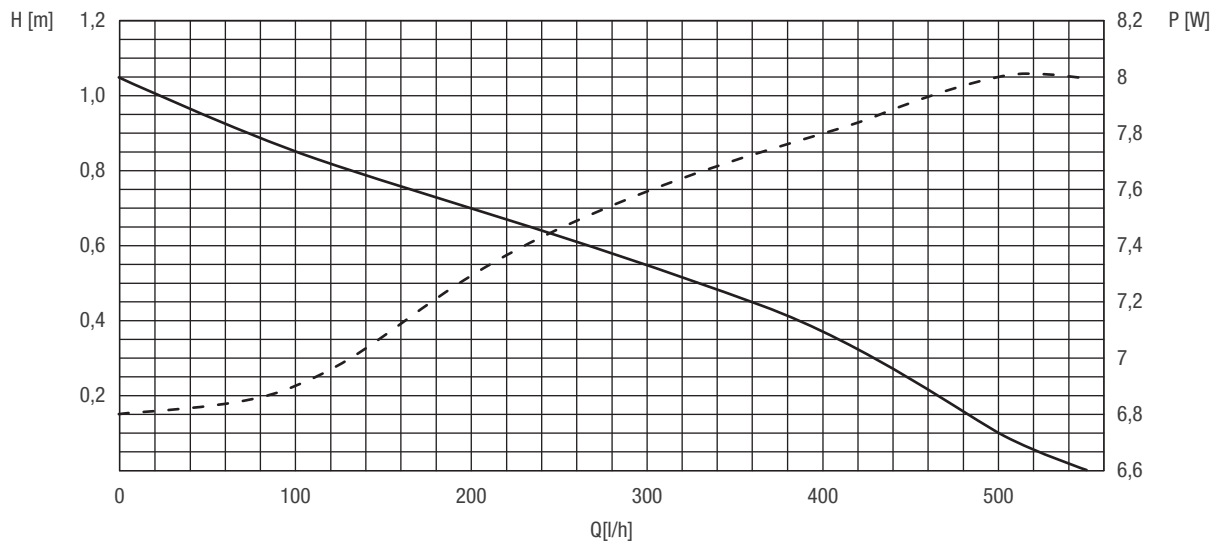

# Module for the production of domestic hot water

## SC ACS 35



- SC ACS 35 is an instant domestic hot water production module that uses a stainless steel brazed plate heat exchanger, which is widely used in combination with inertial storage systems.
- The domestic hot water temperature is controlled by thermostatic mixing of the primary circuit fluid.
- The low consumption modulating circulation pump of the primary circuit is controlled by a flow switch located on the DHW line and electrically connected in series. There are two loading/unloading cocks that allow, by closing the shut-off valves, the heat exchanger flushing.
- For maximum comfort, a domestic hot water recirculation kit is available.
- SC ACS 35 is supplied complete with insulated frame.

## Technical data

Description	Unit	SC ACS 35
Absorbed heat output with storage system at 50°C and DHW withdrawal 10-45°C	kW	54
DHW withdrawal 10-45°C with storage at 50°C	l/min	22
Absorbed heat output with storage system at 55°C and DHW withdrawal 10-45°C	kW	68
DHW withdrawal 10-45°C with storage at 55°C	l/min	28
Absorbed heat output with storage system at 60°C and DHW withdrawal 10-40°C	kW	80
DHW withdrawal 10-40°C with storage at 60°C	l/min	38
Maximum output for primary side	l/h	1700
Minimum allowed temperature on the DHW side	°C	2
Maximum operating temperature	°C	90
Maximum operating pressure for primary side	bar	10
Primary non-return valve opening pressure	mbar	28
Secondary non-return valve opening pressure	mbar	28
Absorbed electrical power	W	45
Power supply voltage	V	230
Power supply frequency	Hz	50-60
Electrical protection level	IP	54
Net weight	kg	19.1
Water volume	l	6.1

Module for the production of domestic hot water SC ACS 35

# Structure

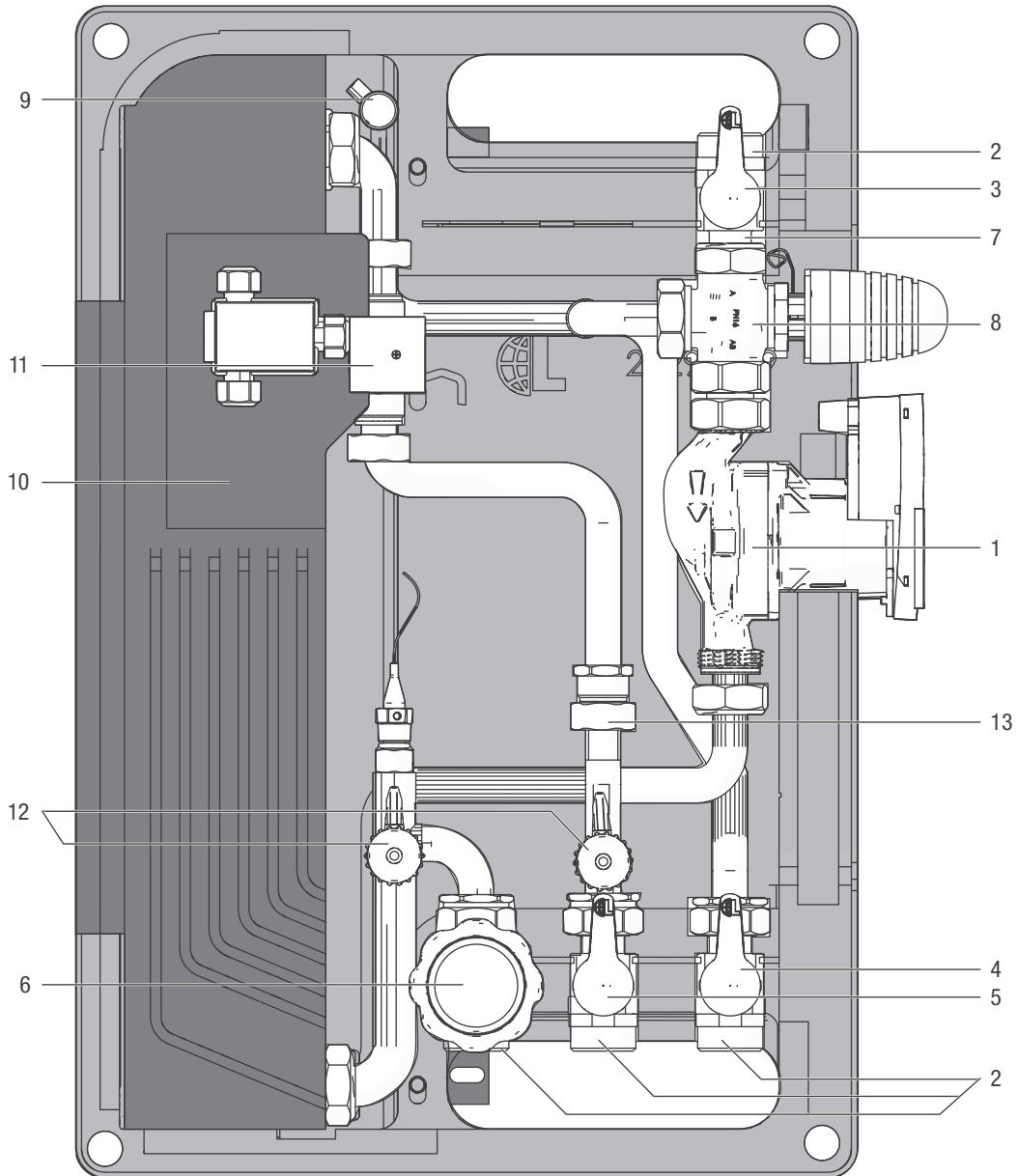

- |   |   |
|---|---|
| <ul style="list-style-type: none"> <li>1. Circulation pump</li> <li>2. Ball valve DN 20 1" M - 3/4"F</li> <li>3. Red handle - primary delivery valve</li> <li>4. Blue handle - primary return valve</li> <li>5. Blue handle - domestic cold water inlet valve</li> <li>6. Black handle - non-return valve with domestic hot water outlet thermometer</li> </ul> | <ul style="list-style-type: none"> <li>8. Three-way mixing valve with thermostatic actuator 35 - 65°C</li> <li>9. 3/8" manual bleeder valve</li> <li>10. Brazed stainless steel plate heat exchanger with insulation</li> <li>11. Flow switch</li> <li>12. 1/2" loading/unloading cock</li> <li>13. Fitting for connection of recirculation kit 3/4" F</li> </ul> |
|---|---|

Module for the production of domestic hot water SC ACS 35

## Dimensions and couplings

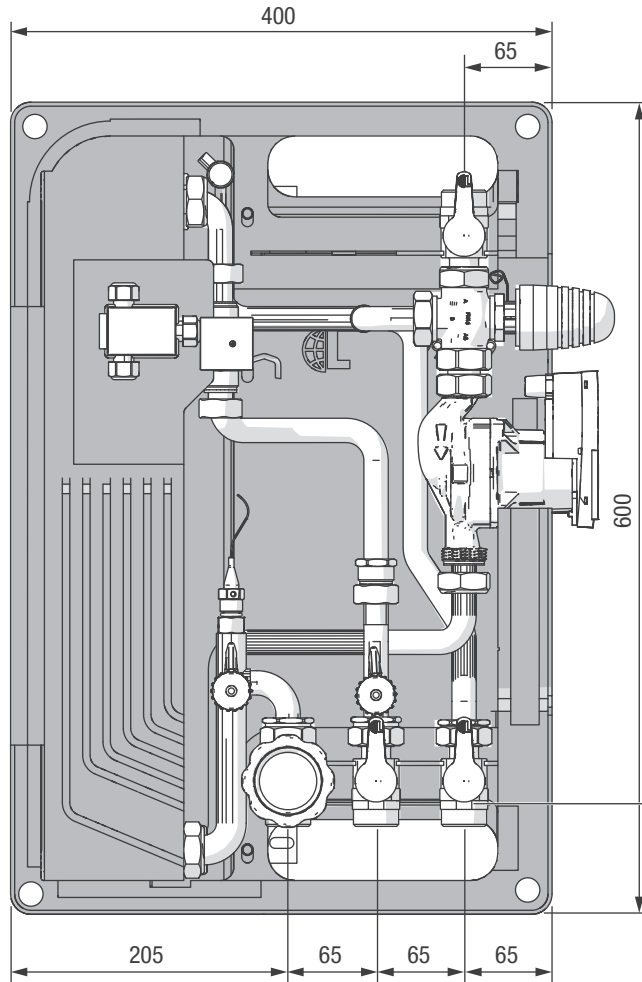

Description	SC ACS 35
Primary delivery line	1" M - 3/4" F
Primary outlet	1" M - 3/4" F
DCW circuit	1" M - 3/4" F
DHW outlet	1" M - 3/4" F
Recirculation	3/4" F
Depth (mm)	250

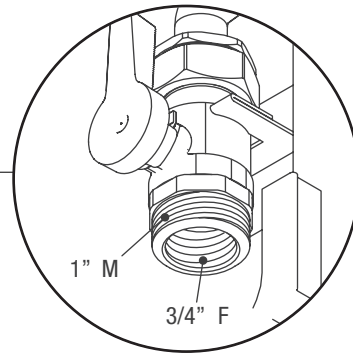

## Hydraulic circuit

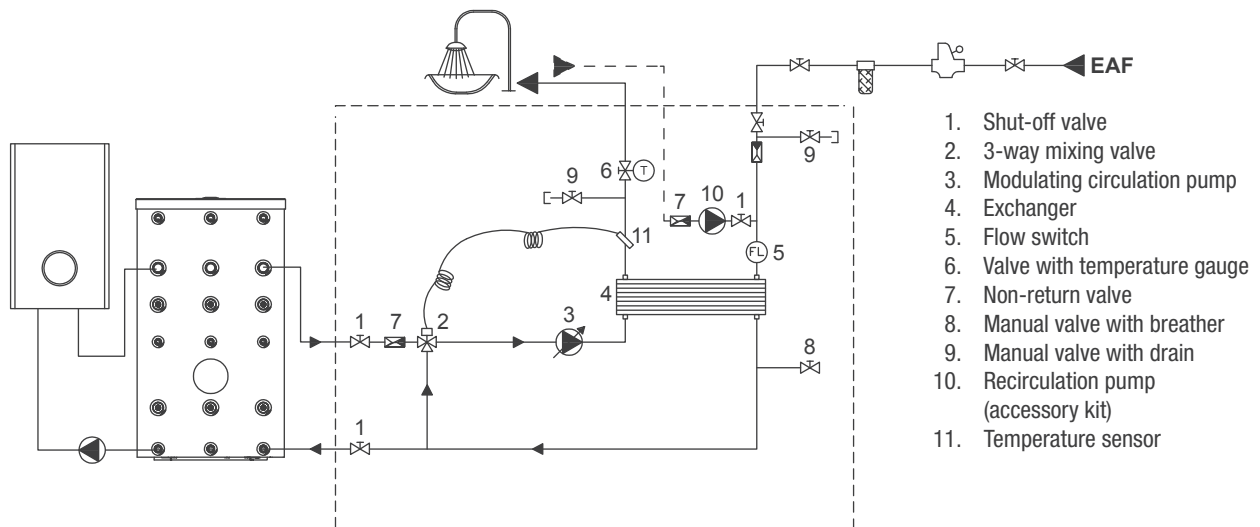

1. Shut-off valve
2. 3-way mixing valve
3. Modulating circulation pump
4. Exchanger
5. Flow switch
6. Valve with temperature gauge
7. Non-return valve
8. Manual valve with breather
9. Manual valve with drain
10. Recirculation pump (accessory kit)
11. Temperature sensor

Module for the production of domestic hot water SC ACS 35

# Chart on production of DHW

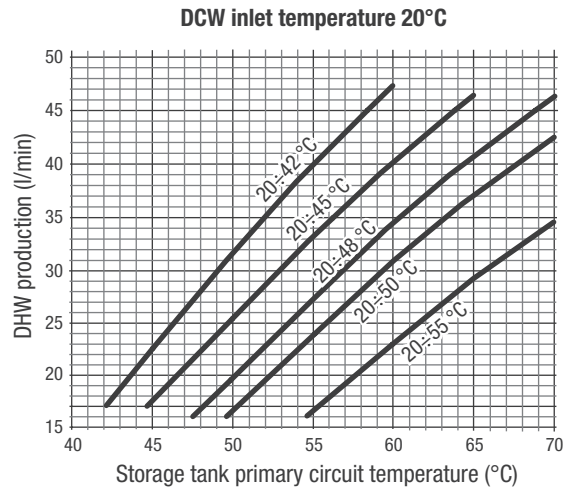
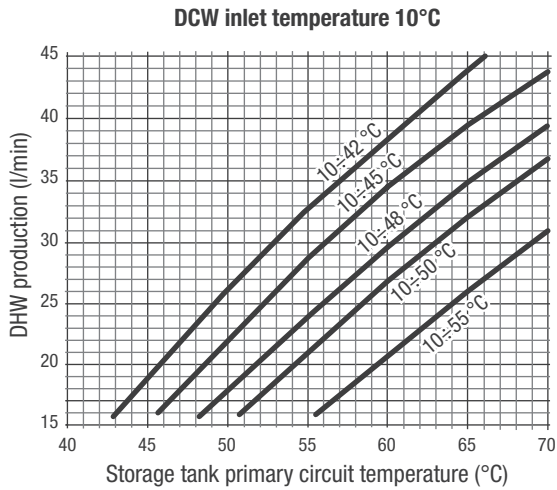

The correct operation of the module is guaranteed if the delivery temperature of the primary circuit is at least 5K higher than the set DHW temperature.

## DHW secondary circuit pressure loss

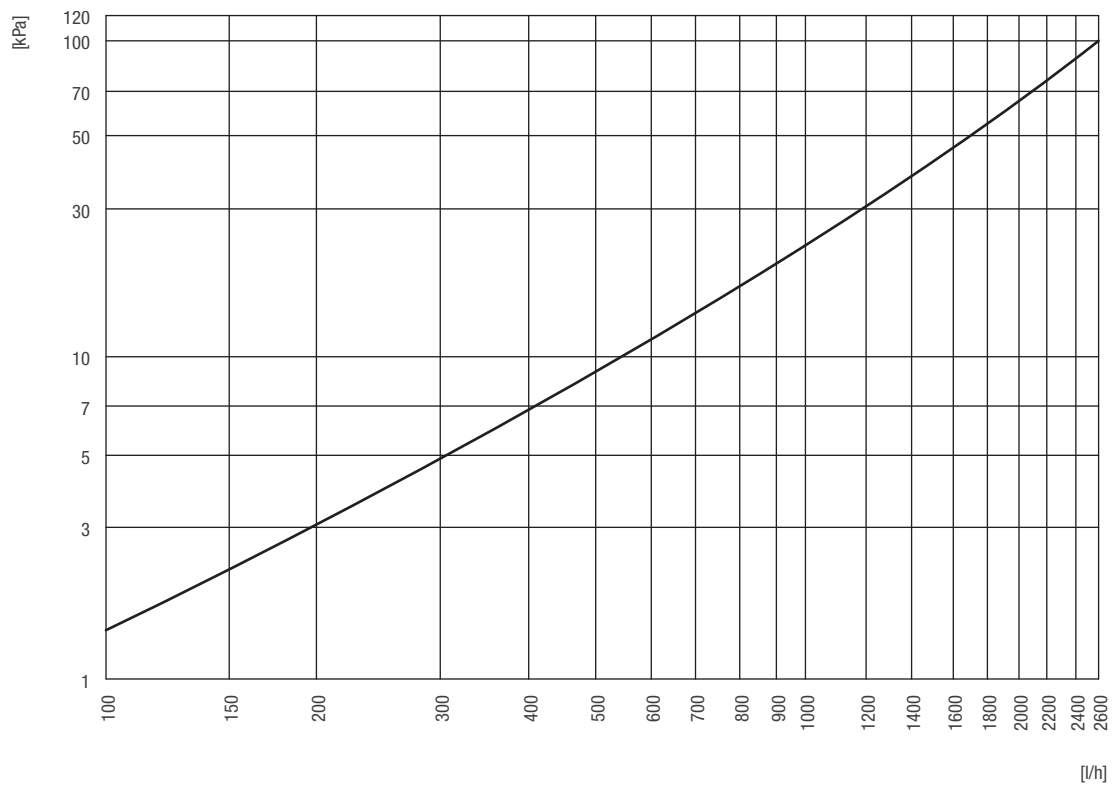

Module for the production of domestic hot water SC ACS 35

# Circulation pump curves

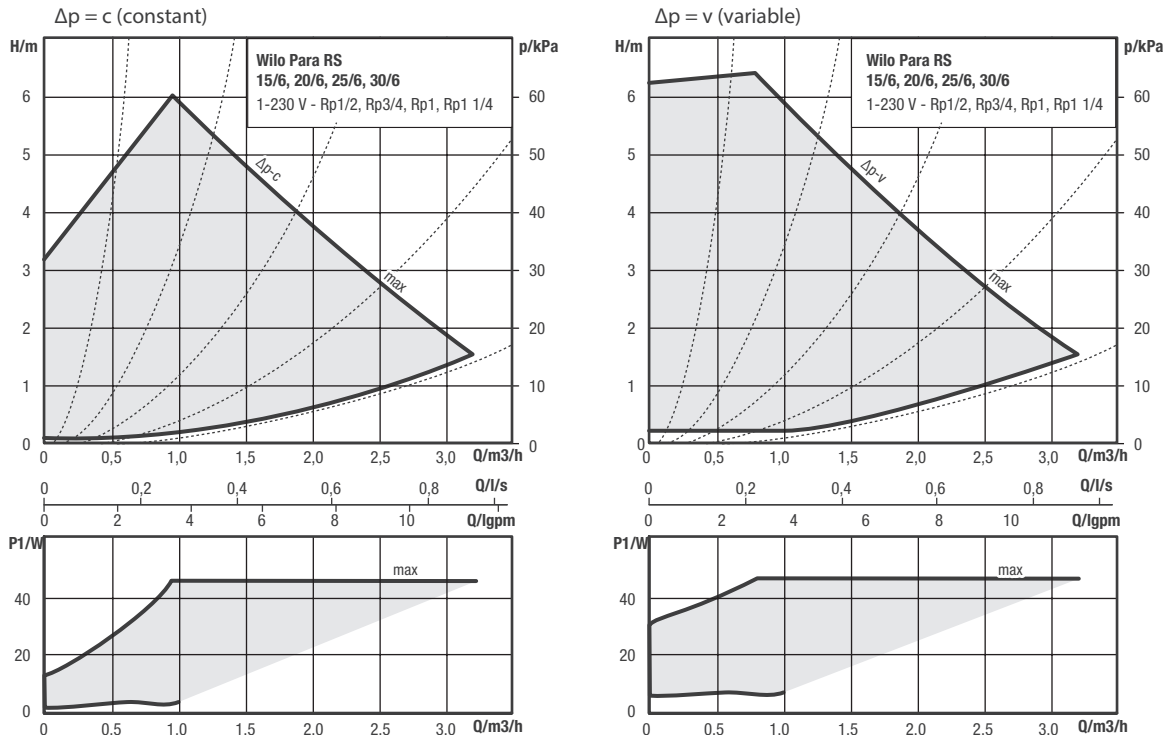

# Wiring diagram

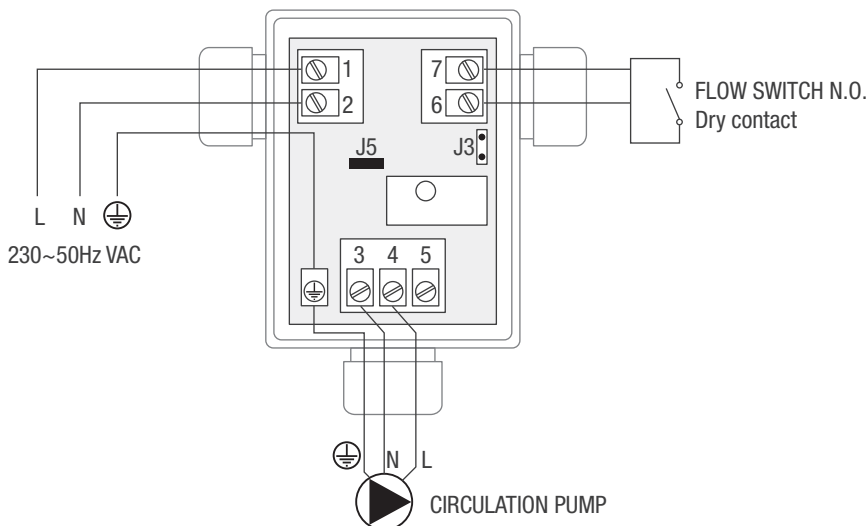

## Electrical wiring

It is mandatory:

- Have a differential magneto-thermal circuit breaker and a disconnecting switch compliant with the prevailing standards of the installation country.
- to comply with the connection L (phase) - N (Neutral); Ensure that the earth conductor is approx. 2 cm longer than power supply cables;
- Connect the device to an efficient earth system.

It is forbidden to use water pipes to earth the device.

It is forbidden to lay the power supply cables in the vicinity of any hot surfaces (delivery pipes). If there is a risk of contact with hot parts, with temperatures exceeding 50°C, a suitable type of cable must be utilized.

## Module for the production of domestic hot water SC ACS 35

### Commissioning

- Check tightness of connection nuts.
- Fill the system and check for any leaks.
- Slowly open the shut-off valves on both the drinking water and hot water sides to decrease pressure surges.
- Venting and bleeding the system:
  - Open a drinking water outlet with hot water distribution located near the system and unscrew the thermostat head as far as possible.
  - Venting on the storage tank side is done through the vent screw on the loading pump. Vent the system completely.
- Set the desired drinking water temperature on the thermostat head.
- Set the circulation unit to the function with constant pressure difference. This allows a constant head value to be maintained within the permitted flow rate range.
- Insert insulation.
- After commissioning, check the operation and tightness of the entire system.

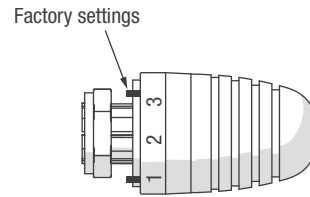

Pos. t	(*C)
1	35
2	40
3	45
4	50
5	55
6	60
7	65

Factory settings

### Hydraulic connection

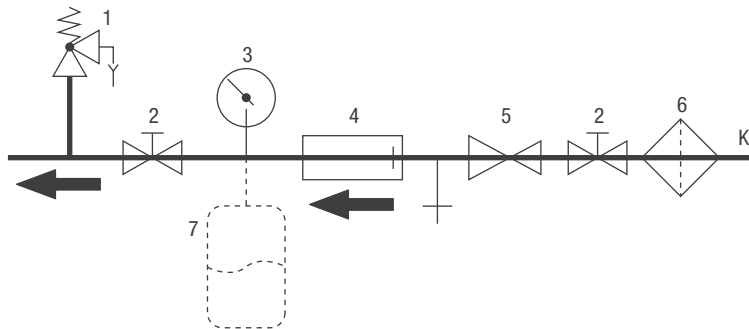

1. Safety valve
  2. Stop valve
  3. Pressure gauge
  4. Non-return device
  5. Pressure reducing valve (required with  $K \geq 6$  bar)
  6. Narrow mesh filter
  7. Expansion vessel (option)
- K Main drinking water connection

### Connection to the water mains

- For domestic hot water production systems, provide an impurity filter to protect the system. In addition, a check valve and an DCW inlet expansion vessel must be provided.
- In case of water with hardness higher than 25÷30 °Fr, it is advisable to install an adequate water treatment system at the inlet of the heating system, in order to avoid possible scale build-up caused by hard water or corrosion due to aggressive water.
- It should be remembered that even a small build-up, just a few millimetres thick causes, because of its low thermal conductivity, a reduction in performance on the DHW side.
- The construction materials of the domestic hot water production module mod. SC ACS 35 comply with the provisions by the Ministerial Decree 174/2004, regulated by Directive 98/83/EC.
- Although the fittings are factory fitted, all screw connections must be checked and further tightened. It is also important to carry out a leak test (pressure test) during commissioning.
- Exceeding the values in the table on the side could lead to damage to the DHW module and inevitably to the warranty becoming null and void. This is why we recommend a water analysis to certify whether the values are within the limits specified in the table.

Components	Units of measurement	Limit values for welded copper heat exchangers
PH		7-9 (considering the saturation index)
Saturation Index ( $\Delta$ PH)		-0.2<0<+0.2
Total hardness	°Fr	15-30
Conductivity	$\mu$ S/cm	10... 500
Substances that can be filtered	mg/l	<30
Free chlorine	mg/l	<0.5
Hydrogen Sulphide	mg/l	<0.05
Ammonia	mg/l	<2
Hydrogen Carbonate	mg/l	<300
Hydrogen Carbonate/Sulphide	mg/l	>1.0
Sulphide	mg/l	<1
Nitrate	mg/l	<100
Nitrite	mg/l	<0.1
Sulphate	mg/l	<100
Manganese	mg/l	<0.1
Dissolved iron	mg/l	<0.2
Free aggressive carbon dioxide	mg/l	<20

Module for the production of domestic hot water SC ACS 35

### System diagram

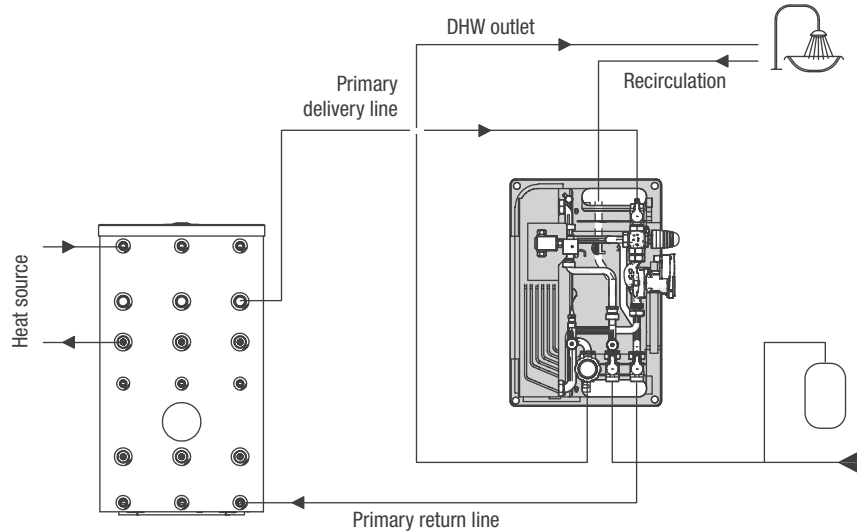

The module must be positioned near the storage tank. The system is dimensioned for a length of the connection pipes between the module and the storage tank of 4 meters (flow + return).

### DHW recirculation kit

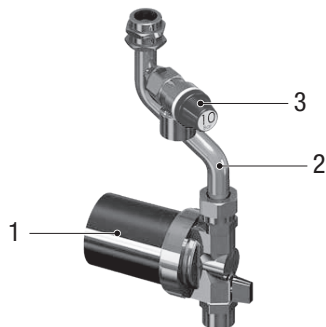

1. Circulation pump
2. Pipes with seals
3. Safety valve

Pumped fluid temperature	2 ÷ 65 °C
Max pressure	10 bar
Power supply	200-240 V
Frequency	50-60 Hz
Protection level	IP 44

### Circulation pump characteristics curves

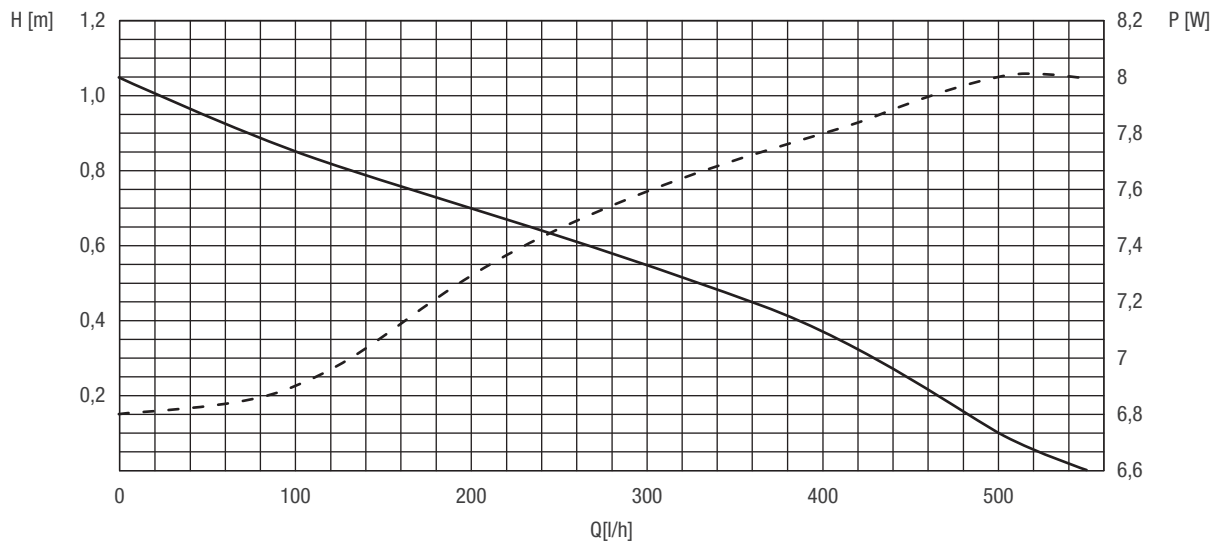

# Module for the production of domestic hot water

## SC ACS 40



- SC ACS 40 is an instant domestic hot water production module that uses a stainless steel brazed plate heat exchanger, which is widely used in combination with inertial storage systems.
- The module is equipped, as standard, with a low-consumption modulating circulation pump and a solar control unit.
- The temperature of the domestic hot water is electronically controlled.
- There are two loading/unloading cocks that allow, by closing the shut-off valves, the heat exchanger flushing.
- For maximum comfort, a domestic hot water recirculation kit is available.
- SC ACS 40 module is supplied complete with insulated frame.

## Technical data

Description	Unit	SC ACS 40
Absorbed heat output with storage system at 50°C and DHW withdrawal 10-45°C	kW	72
DHW withdrawal 10-45°C with storage at 50°C	l/min	29.5
Absorbed heat output with storage system at 55°C and DHW withdrawal 10-45°C	kW	90
DHW withdrawal 10-45°C with storage at 55°C	l/min	37
Absorbed heat output with storage system at 60°C and DHW withdrawal 10-40°C	kW	92
DHW withdrawal 10-40°C with storage at 60°C	l/min	44
Maximum output for primary side	l/h	1850
Minimum allowed temperature on the DHW side	°C	5
Maximum operating temperature	°C	90
Maximum operating pressure for primary side	bar	10
Primary non-return valve opening pressure	mbar	28
Secondary non-return valve opening pressure	mbar	28
Absorbed electrical power	W	48
Power supply voltage	V	230
Power supply frequency	Hz	50-60
Electrical protection level	IP	40
Net weight	kg	19.2
Water content	l	6.6

Module for the production of domestic hot water SC ACS 40

# Structure

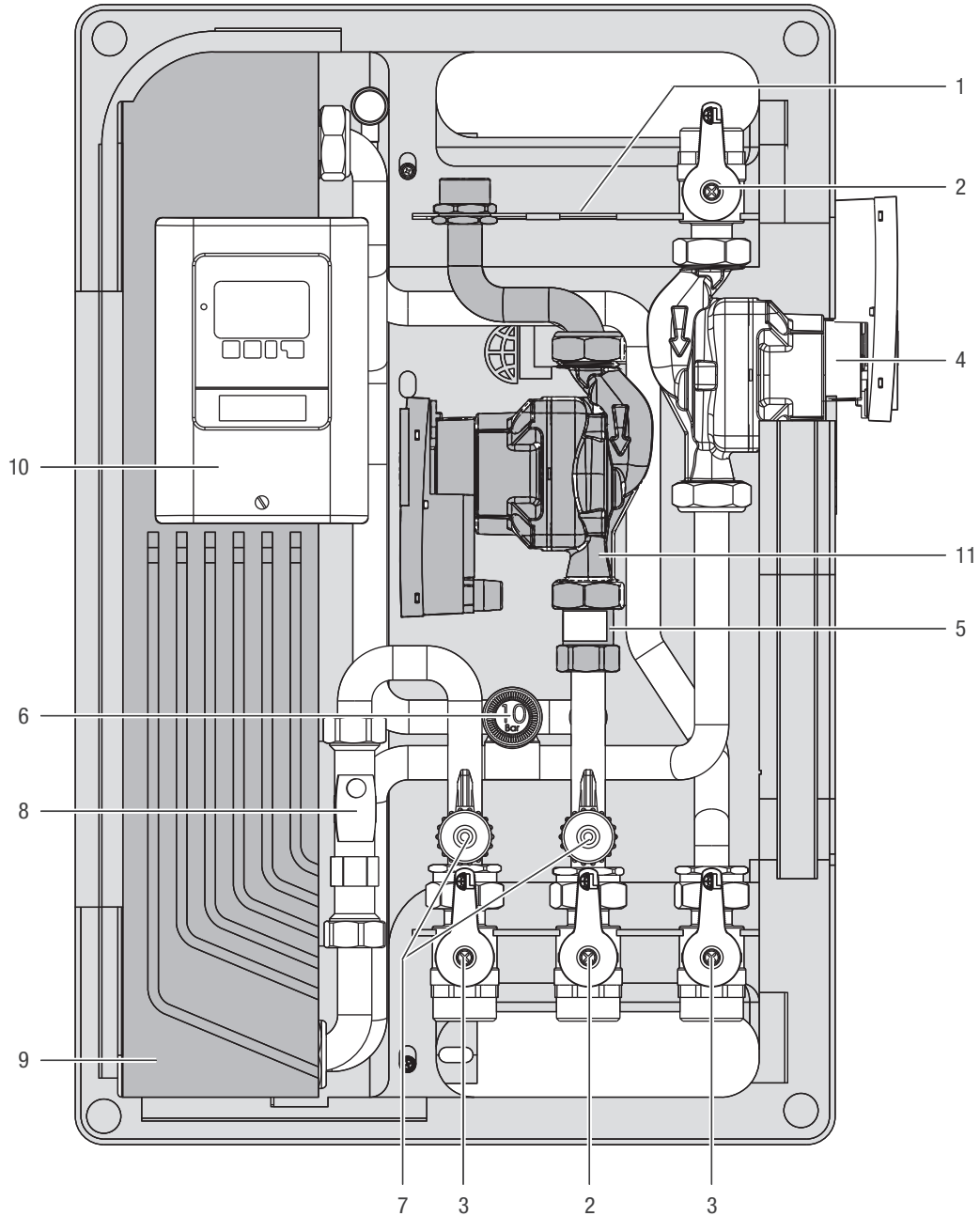

1. Insulated galvanized sheet metal support
2. Ball valve DN 20 3/4" F - 1" M (with check function)
3. Ball valve DN 20 3/4" F - 1" M
4. Circulation pump (primary side)
5. Non-return valve (recirculation circuit)
6. 10-bar safety valve (secondary side)
7. 1/2" loading/unloading cock
8. Flow and temperature meter (secondary side)
9. Brazed stainless steel plate heat exchanger
10. Electronic control unit
11. Recirculation circuit

Module for the production of domestic hot water SC ACS 40

# Dimensions and couplings

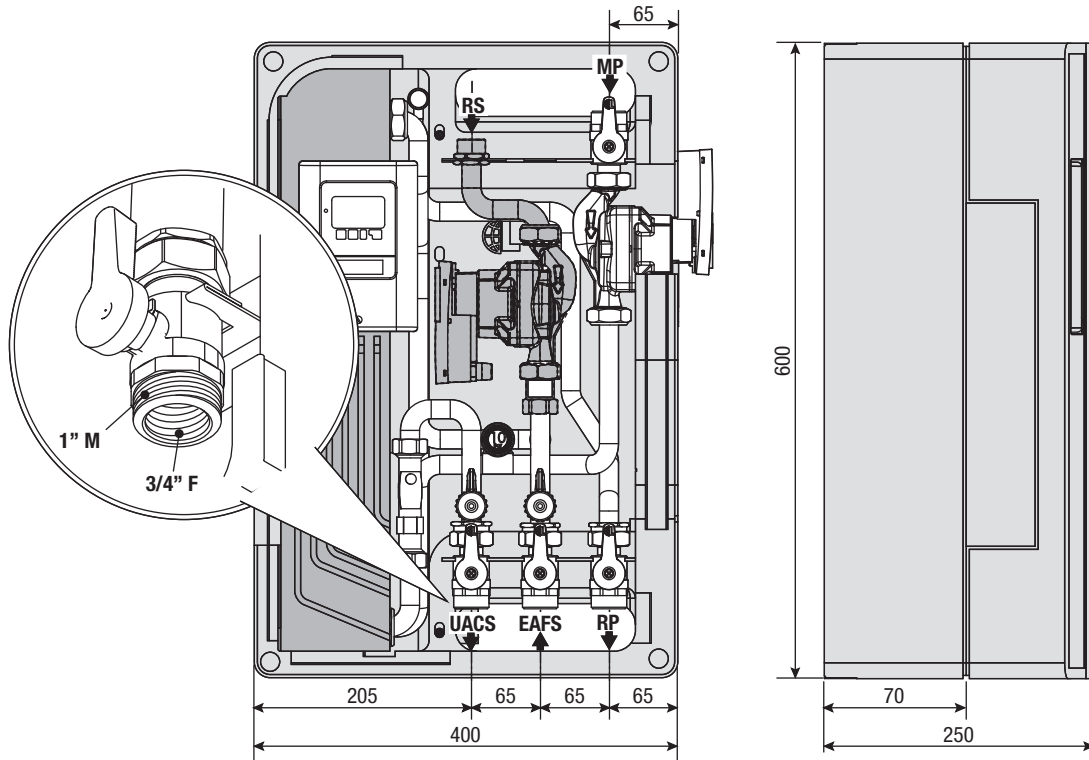

Description	SC ACS 40
MP - Primary delivery line	1" M - 3/4" F
RP - Primary return line	1" M - 3/4" F
EAFS - DCW inlet	1" M - 3/4" F
UACS - DHW outlet	1" M - 3/4" F
RS - Domestic water inlet	3/4" M

# Hydraulic circuit

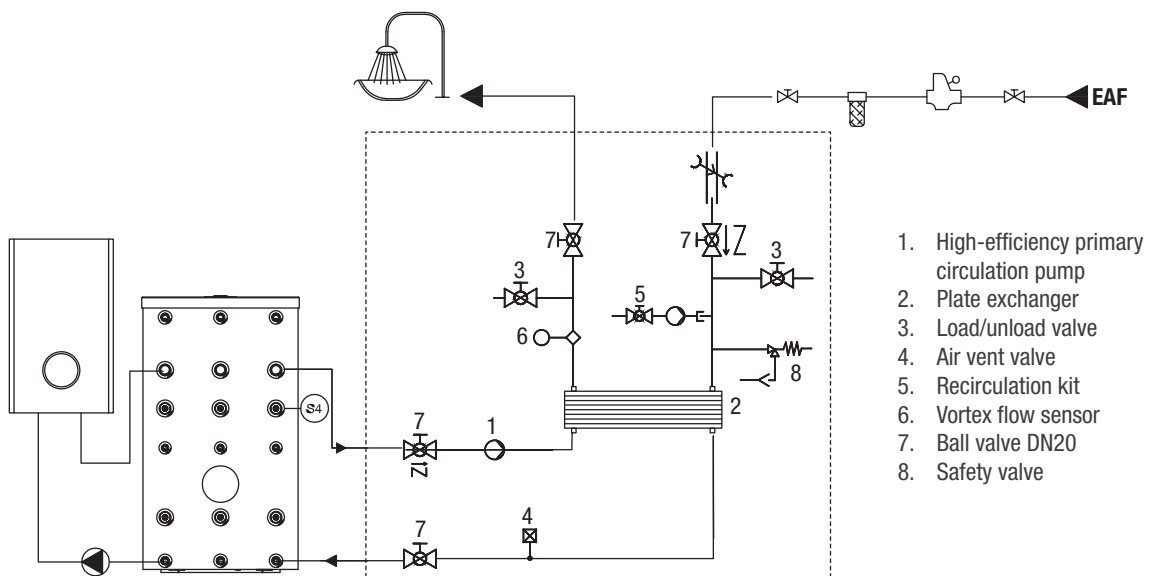

1. High-efficiency primary circulation pump
2. Plate exchanger
3. Load/unload valve
4. Air vent valve
5. Recirculation kit
6. Vortex flow sensor
7. Ball valve DN20
8. Safety valve

Module for the production of domestic hot water SC ACS 40

### Chart on production of DHW

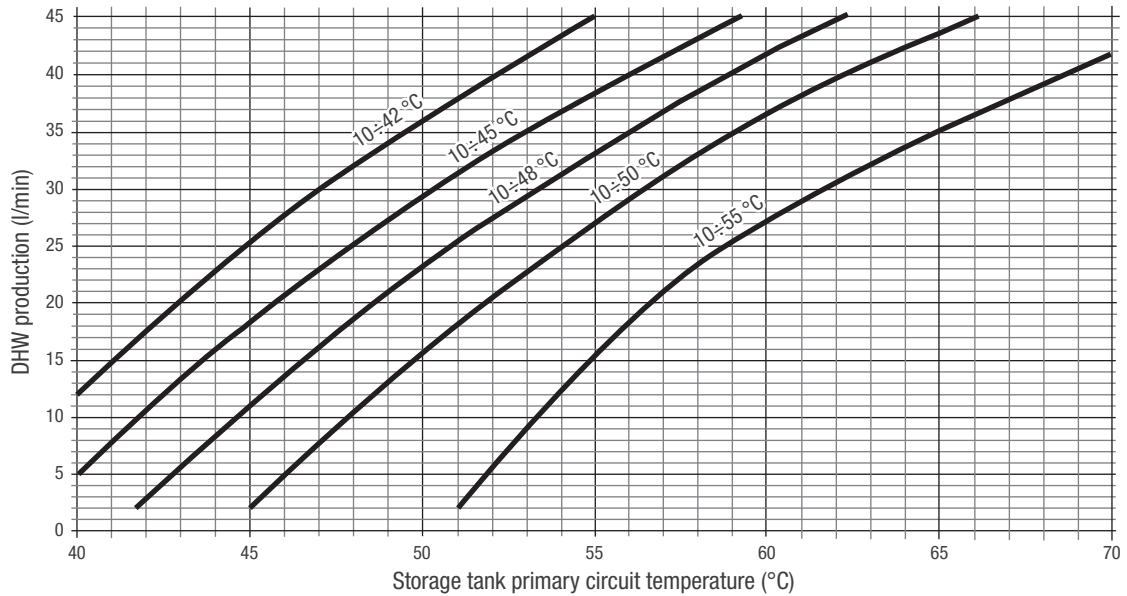

The correct operation of the module is guaranteed if the delivery temperature of the primary circuit is at least 5K higher than the set DHW temperature.

### Circulation pump curves

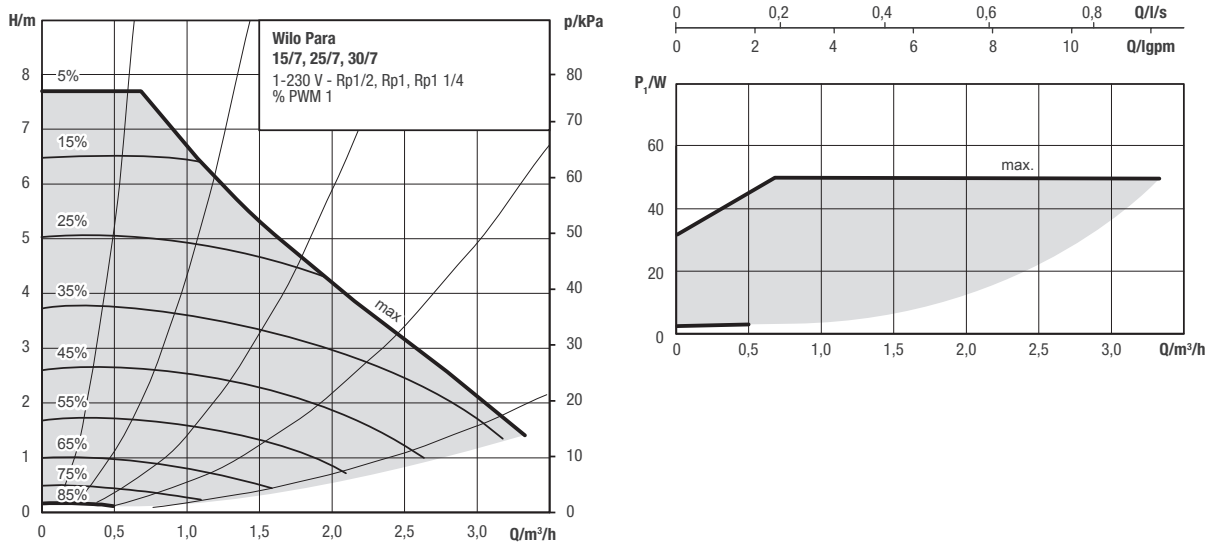

Module for the production of domestic hot water SC ACS 40

# Wiring diagram

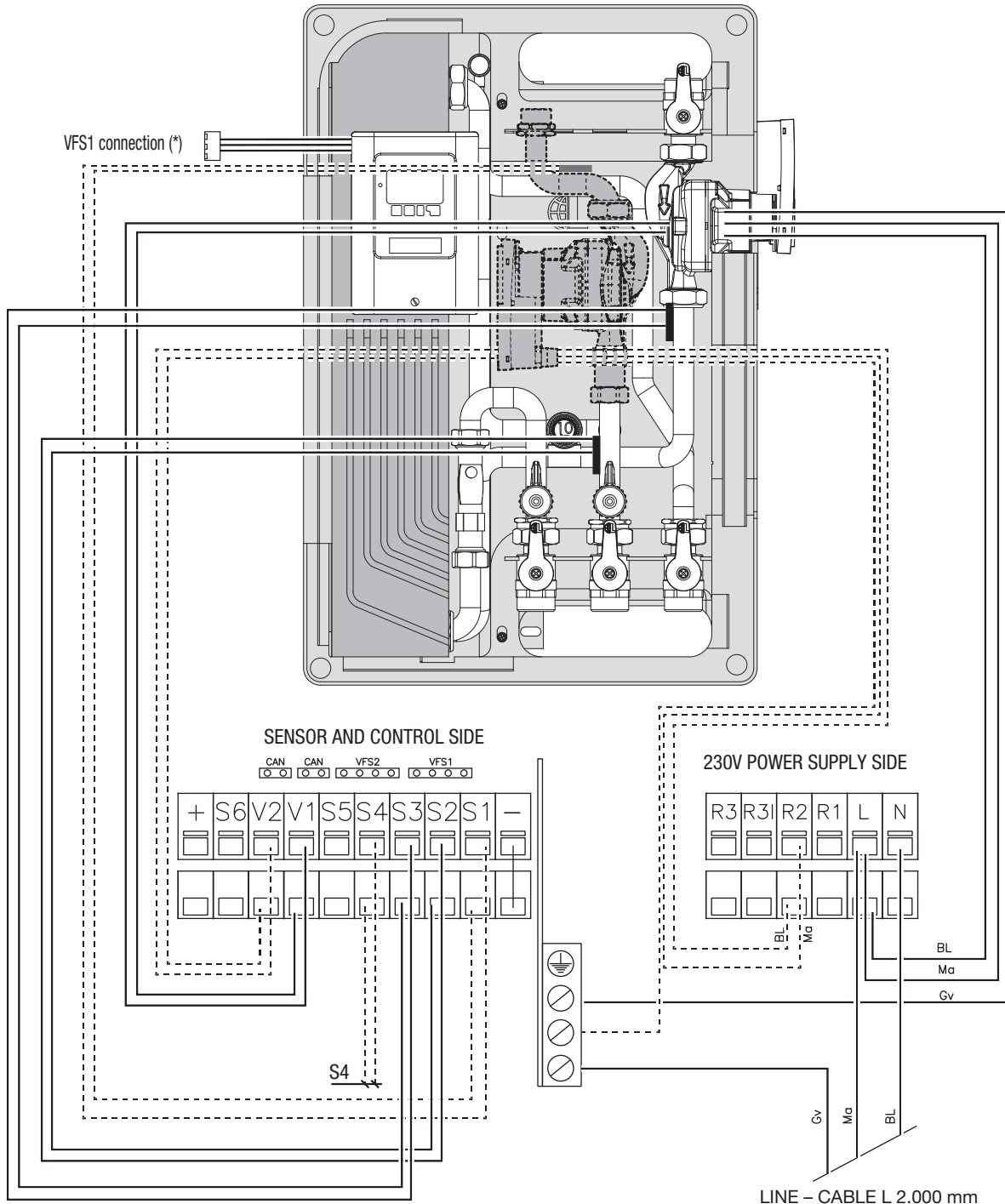

- V1 PWM1 primary circulation pump
- V2 PWM2 recirculation circulation pump
- S1 PT1000 recirculation S1 (optional)
- S2 PT1000 cold water S2
- S3 PT1000 primary S3
- S4 PT1000 storage system S4 high
- S5 Not used

- GND Earth
- MA Phase L / primary pump main line
- BL Neutral N / primary pump main line
- (\*) Insert terminal VFS1 in the control unit

## Module for the production of domestic hot water SC ACS 40

### Electrical wiring

It is mandatory:

- Have a differential magneto-thermal circuit breaker and a disconnecting switch compliant with the prevailing standards of the installation country.
- to comply with the connection L (phase) - N (Neutral); Ensure that the earth conductor is approx. 2 cm longer than power supply cables;
- Connect the device to an efficient earth system.

It is forbidden to use water pipes to earth the device.

It is forbidden to lay the power supply cables in the vicinity of any hot surfaces (delivery pipes). If there is a risk of contact with hot parts, with temperatures exceeding 50°C, a suitable type of cable must be utilized.

### Hydraulic connection

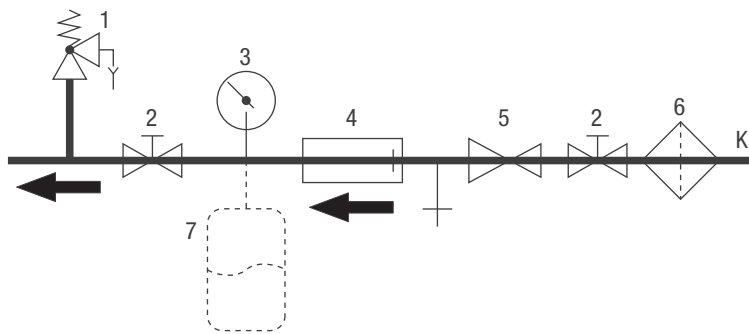

1. Safety valve
2. Stop valve
3. Pressure gauge
4. Non-return device
5. Pressure reducing valve (required with  $K \geq 6$  bar)
6. Narrow mesh filter
7. Expansion vessel (option)
- K Main drinking water connection

### Connection to the water mains

- For domestic hot water production systems, provide an impurity filter to protect the system. In addition, a check valve and an DCW inlet expansion vessel must be provided.
- In case of water with hardness higher than 25÷30 °Fr, it is advisable to install an adequate water treatment system at the inlet of the heating system, in order to avoid possible scale build-up caused by hard water or corrosion due to aggressive water.
- It should be remembered that even a small build-up, just a few millimetres thick causes, because of its low thermal conductivity, a reduction in performance on the DHW side.
- The construction materials of the domestic hot water production module mod. SC ACS 40 comply with the provisions by the Ministerial Decree 174/2004, regulated by Directive 98/83/EC.
- Although the fittings are factory fitted, all screw connections must be checked and further tightened. It is also important to carry out a leak test (pressure test) during commissioning.
- Exceeding the values in the table on the side could lead to damage to the DHW module and inevitably to the warranty becoming null and void. This is why we recommend a water analysis to certify whether the values are within the limits specified in the table.

Components	Units of measurement	Limit values for welded copper heat exchangers
PH		7-9 (considering the saturation index)
Saturation Index ( $\Delta PH$ )		$-0.2 < 0 < +0.2$
Total hardness	°Fr	15-30
Conductivity	$\mu S/cm$	10... 500
Substances that can be filtered	mg/l	<30
Free chlorine	mg/l	<0.5
Hydrogen Sulphide	mg/l	<0.05
Ammonia	mg/l	<2
Hydrogen Carbonate	mg/l	<300
Hydrogen Carbonate/Sulphide	mg/l	>1.0
Sulphide	mg/l	<1
Nitrate	mg/l	<100
Nitrite	mg/l	<0.1
Sulphate	mg/l	<100
Manganese	mg/l	<0.1
Dissolved iron	mg/l	<0.2
Free aggressive carbon dioxide	mg/l	<20

Module for the production of domestic hot water SC ACS 40

# DHW recirculation kit

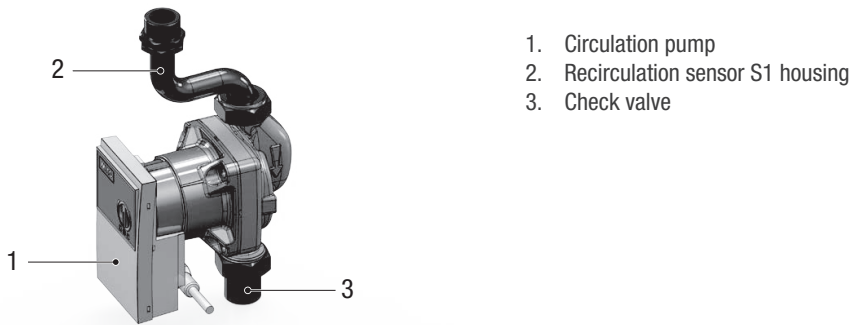

## Circulation pump characteristics curves

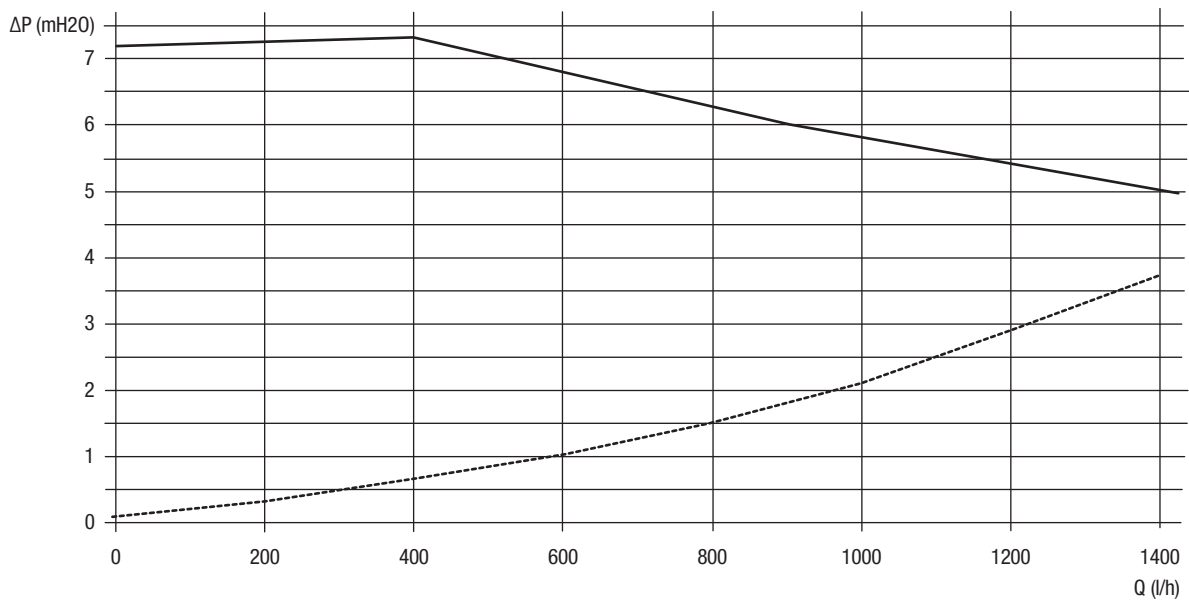

**Module for the production of domestic hot water SC ACS 40**

**Accessory wiring diagram**

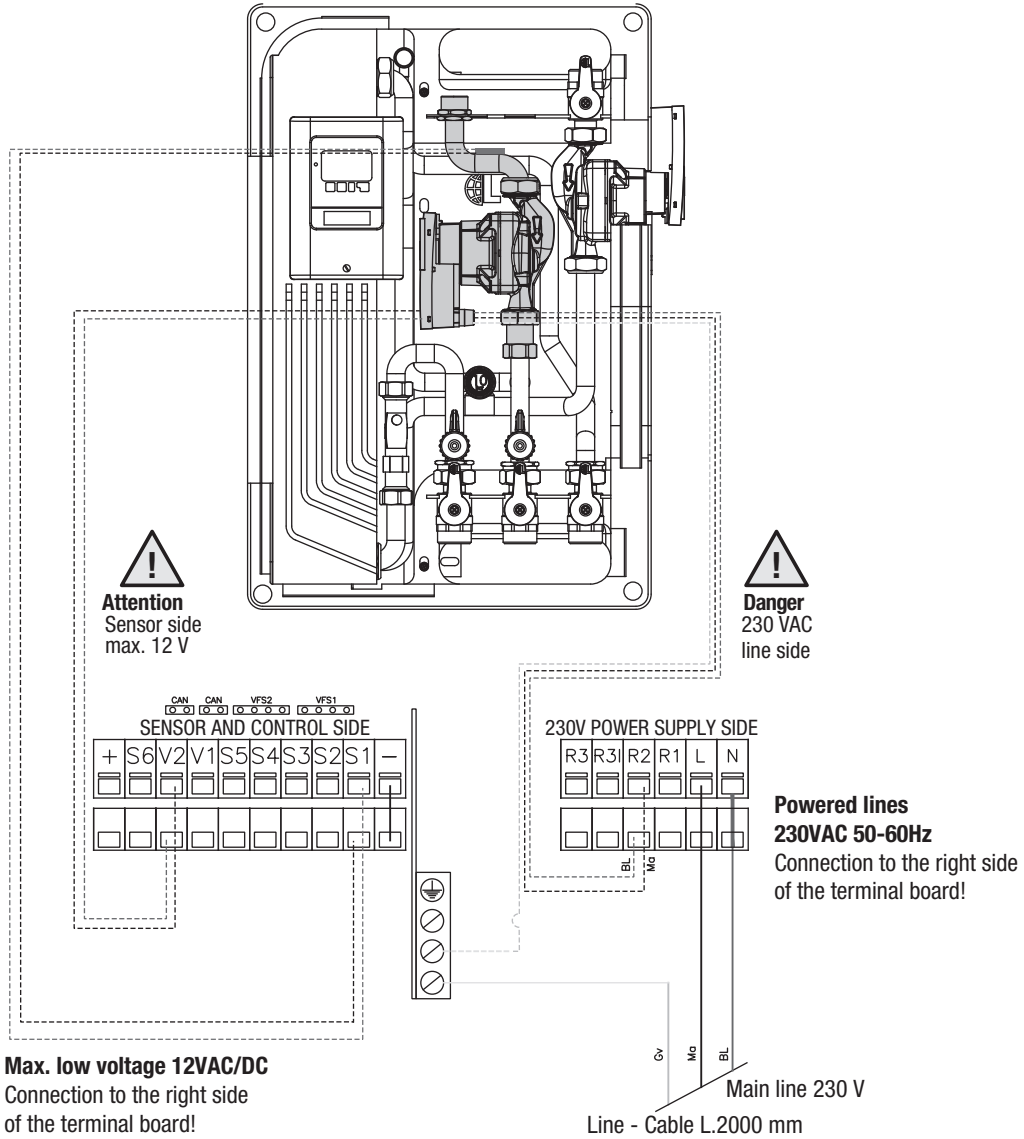

Module for the production of domestic hot water SC ACS 40

# System diagram

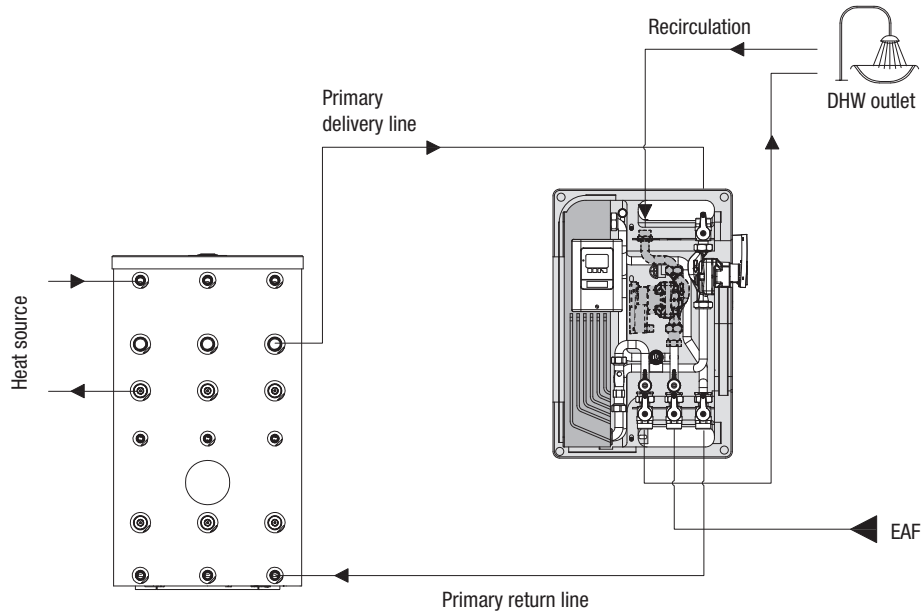

The module must be positioned near the storage tank. The system is dimensioned for a length of the connection pipes between the module and the storage tank of 4 meters (flow + return).

In case of recirculation, provide a properly sized expansion vessel in order to avoid overpressure due to thermal expansion and water hammer.

# Cascade-connected system diagram

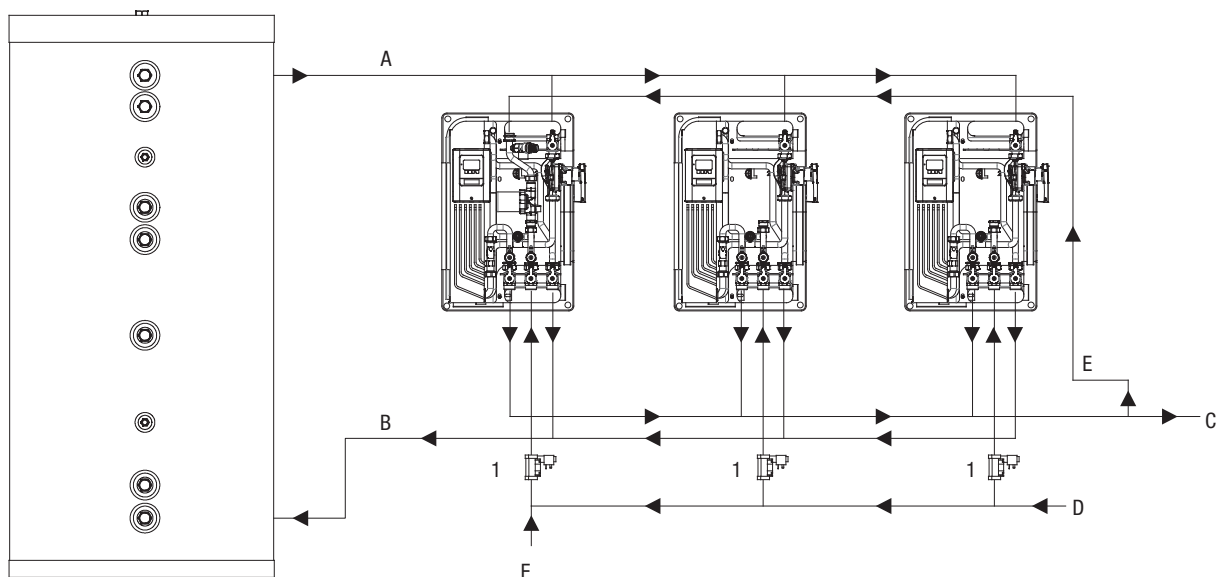

## Module for the production of domestic hot water SC ACS 40

### Control unit

The MWFC control unit allows efficient use and control of the system operation. For each programming point, the data is associated with certain functions with additional explanations. The menu of the control unit contains keywords for settings and measured values, but also help texts and graphs.

Main features of the MFWC:

- Displaying of graphs and texts on the display.
- Simple control of measured current values.
- Analysis and monitoring of the system through statistical graphs, etc.
- Extensive setting menus with explanations.

- The menu lock can be activated to prevent unwanted changes.
- Function to restore previous values or factory settings.
- Wide range of additional functions.

### Disposal

The control unit complies with the European RoHS Directive 2002/95/EC which concerns restrictions on the use of certain substances in electrical and electronic equipment.



### Technical Specifications

<b>Electrical Specifications</b>	
Voltage	230 VAC ±10%
Frequency	50 ÷ 60 Hz
Current consumption	2 VA
Contact power	
mechanical relay R1 - R3	460 VA for AC1 / 460 W for AC3
PMV outlet	for working resistance 10 kΩ
Internal fuse	T2A / 250 V slow-blow
Protection level	IP40
Protection class	II
Inlet sensors	6 × PT1000 + 2 × Vortex flow sensor (VFS)
Measurement range	PT1000 -40 °C up to 300 °C
Vortex sensor	0 °C to 100 °C (-25 °C /120 °C short time)
1 l/min - 12 l/min (VFS1-12)	0-0.6 bar
1 l/min - 20 l/min (VFS1-20)	0-1 bar
2 l/min - 40 l/min (VFS2-40)	0-1.6 bar
5 l/min - 100 l/min (VFS5-100)	0-2.5 bar
10 l/min - 200 l/min (VFS10-200)	0-4 bar
	0-6 bar
	0-10 bar
<b>Allowed climatic conditions</b>	
Ambient temperature:	
for control unit operation	0 °C ÷ 40 °C
for transport/storage	0 °C ÷ 60 °C
Air humidity:	
for control unit operation	max. 85% relative humidity with 25 °C
for transport/storage	no moisture condensation allowed
<b>Other specifications and dimensions</b>	
Enclosure	3 Parts, ABS Plastic
External dimensions	163 mm × 110 mm × 52 mm
Opening dimensions for installation	157 mm × 106 mm × 31 mm
Display	large graphic display, 128×128 points
LED	multicolour green/red
Programming	4 buttons

### Temperature resistance table for PT1000 sensors

<b>Resistance [Ω]</b>	1000	1039	1077	1116	1155	1194	1232	1270	1308	1347	1385
<b>Temperature [°C]</b>	0	10	20	30	40	50	60	70	80	90	100

## Module for the production of domestic hot water SC ACS 40

# Key functions

## Recirculation

When the "Request" mode is active, the recirculation pump will be activated after a water withdrawal and remain active until the target recirculation temperature (recirculation  $T_{min}$  + hysteresis) is reached at the recirculation sensor.

In "Time" mode, the circulation pump is active during the set times and when the set minimum circulation temperature is not reached and remains on until the required circulation temperature (recirculation  $T_{min}$  + hysteresis) is reached at the circulation sensor. Request+Time: The circulation pump is active during the enabled times and when the temperature is below the set minimum recirculation one or when there is water withdrawal.

The recirculation remains active until the required recirculation temperature (recirculation  $T_{min}$  + hysteresis) is reached at the recirculation sensor.

Always on: The recirculation pump is switched on at the set times.

### Recirculation $T_{min}$ = minimum temperature of sensor S1

If the temperature drops below recirculation  $T_{min}$  and the circulation is active, the pump is activated.

Setting range: 10 °C to 85 °C

### Recirculation hysteresis = Disable recirculation pump shut-off hysteresis

If the temperature exceeds  $T_{min}$  S1 the pump is switched off.

Parameter range: 1-20K

### Maximum recirculation flow rate = maximum recirculation pump flow rate

If the flow rate measured at sensor 6 exceeds this value, the recirculation pump is switched off.

Parameter range: 1-50 l/min.

### Recirculation time = sets the operating times of the pump

You can set 3 different times for each day of the week, you can then copy them to the other days.

Out of the defined timeframes, recirculation is not active. The set times are only used in the "Time" recirculation mode.

## Withdrawal support

To ensure a constant temperature even with small withdrawals, the recirculation pump can be used as a backup pump.

The pump is activated not only under normal conditions, but also with small withdrawals.

When a storage sensor is connected, the withdrawal support is activated when the storage  $T_{min}$  is reached at the storage sensor.

## Minimum storage temperature

The withdrawal support is deactivated when the storage temperature falls below the "minimum storage temperature".

## Withdrawal support measurement

See "F3. - Calibration".

## Storage stratification

The storage stratification function starts a valve that brings the return in the central or lower part of the storage tank, depending on the temperature. Use this menu to set the temperature difference between return and storage. If the return temperature exceeds the storage temperature by the value set here, the central part of the storage tank is loaded.

If no storage sensor is connected, a storage temperature of 25 °C is set.

## Comfort

With the comfort function active, the heat exchanger is fed by the primary circuit pump for 5 seconds every 15 minutes, so that the hot water is made available as quickly as possible when it is drawn off.

## Anti-legionella

With the AL function activated, the MFWC control unit makes it possible to heat the lines and the storage tank at selectable times (AL Time) for the set time (AL time required), until the required AL  $T_{set}$  temperature is reached.

The temperature measured on the S4 has as a reference  $T_{set}$  AL + 5 °C. When the AL function is active,  $T_{max}$  is set to AL  $T_{set}$  + 10 °C to prevent the system from shutting down due to high temperature. The AL function ends only when a temperature of at least "AL  $T_{set}$  - 5 °C" is reached on the hot water sensor and, if present, on the recirculation sensor for the time set in "AL required time". The display shows "Last heating AL". If AL is not completed after 2 hours, the attempt will be cancelled and an error message will appear.

## Limescale protection

To prevent limescale build-up, the circulation pump can continue to feed the heat exchanger for 5÷30 seconds after a withdrawal until the water temperature falls below the value set for the recirculation.

## Automatic Setpoint adjustment

This function is used if the necessary temperature in the primary circuit is not always guaranteed.

With this function activated:

When the storage sensor is not connected:

If the setpoint temperature is not reached after 60 seconds, the -3 °C temperature is used as the new setpoint. Once the pump in the primary circuit stops, the setpoint temperature is raised again up to  $T_{set}$ .

When the storage sensor is connected:

if the temperature at the storage sensor is lower than  $T_{set}$  - 5 °C, the desired temperature is lowered to - 5 °C.

In both cases "  $T_{min}$  recirculation" is decreased to the new setpoint temperature - recirculation hysteresis - 5°C, where "  $T_{min}$  recirculation" is not lower than 0°C and not higher than  $T_{min}$  recirculation setpoint.

## Anti-jam protection

If the anti-jam function is active, the control unit will activate the relay and connected components every day at 12:00 noon ("daily" setting) or weekly every Sunday at 12:00 noon ("weekly" setting) for 5 seconds to prevent the pump and/or valve from blocking after a long period of inactivity.

# Module for the production of domestic hot water

## SC ACS 80



- SC ACS 80 is an instant domestic hot water production module with electronic control using a stainless steel brazed plate heat exchanger, which is widely used in combination with inertial storage systems.
- Domestic hot water (secondary) temperature control is achieved by modulating the flow rate of the primary transfer fluid through a high-efficiency variable flow circulation pump, controlled by the LFWC electronic controller (PWM control).
- Thanks to the low temperatures required in the primary circuit, the system finds excellent use in thermal solar systems and in low temperature heating systems.
- The primary circuit features a 3-way mixing valve to stabilise the inlet temperature (this function is ideal in summer, when the system is integrated with solar collectors).

## Technical data

Description	Unit	SC ACS 80
Absorbed heat output with storage system at 50°C and DHW withdrawal 10-45°C	kW	134
DHW withdrawal 10-45°C with storage at 50°C	l/min	55
Absorbed heat output with storage system at 55°C and DHW withdrawal 10-45°C	kW	146
DHW withdrawal 10-45°C with storage at 55°C	l/min	60
Absorbed heat output with storage system at 60°C and DHW withdrawal 10-40°C	kW	196
DHW withdrawal 10-40°C with storage at 60°C	l/min	64
Maximum output for primary side	l/h	3600
Minimum allowed temperature on the DHW side	°C	2
Maximum operating temperature	°C	90
Maximum operating pressure for primary side	bar	6
Primary non-return valve opening pressure	mbar	28
Secondary non-return valve opening pressure	mbar	28
Absorbed electrical power	W	132
Power supply voltage	V	230
Power supply frequency	Hz	50-60
Electrical protection level	IP	40
Net weight	kg	30
Water content	l	19

Module for the production of domestic hot water SC ACS 80

# Structure

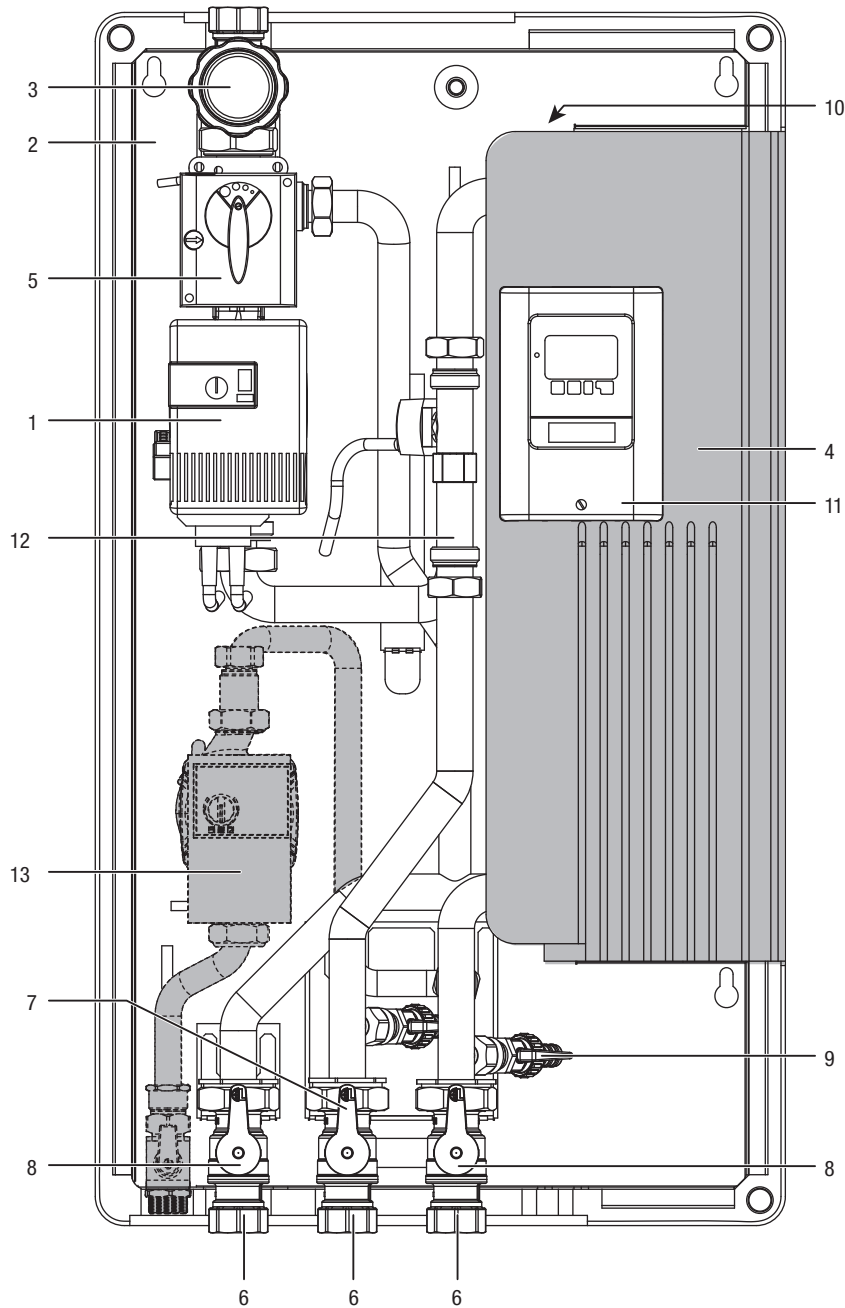

- 1. Primary circulation pump
- 2. Black painted frame template
- 3. Black handle with red thermometer (primary circuit)
- 4. Brazed stainless steel plate heat exchanger with insulation
- 5. Mix valve "TV3" DN25 with servomotor NRYC230;
- 6. Ball valve DN25 with cap 1" 1/2
- 7. Red handle
- 8. Blue handle
- 9. 1/2" load-unload valve

- 10. 3/8" manual air vent valve
- 11. Electronic controller mod. LFWC
- 12. Flowmeter Vortex flow sensor 5-100 l/min
- 13. DHW recirculation kit (supplied separately) consisting of: Wilo PARA Z 15/7 iPWM2 circulation pump, Molex connector, M-F 3/4" cock, straight tang with check valve, PT1000 immersion sensor and sensor holder, pipes and accessories.

Module for the production of domestic hot water SC ACS 80

# Dimensions and couplings

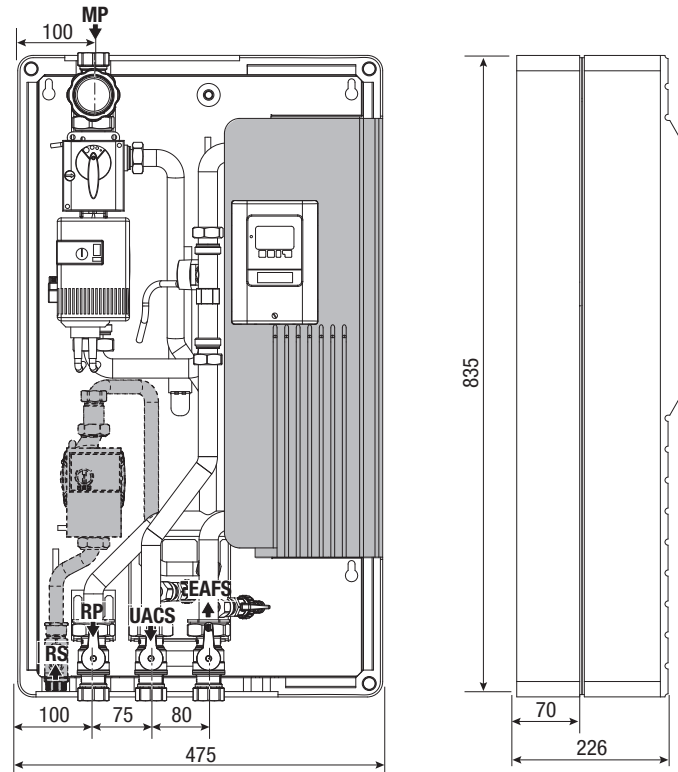

Description	SC ACS 80
MP - Primary delivery line	1" F
RP - Primary return line	1" F
EAFS - DCW inlet	1" F
UACS - DHW outlet	1" F
RS - Domestic water inlet	3/4" M

# Hydraulic circuit

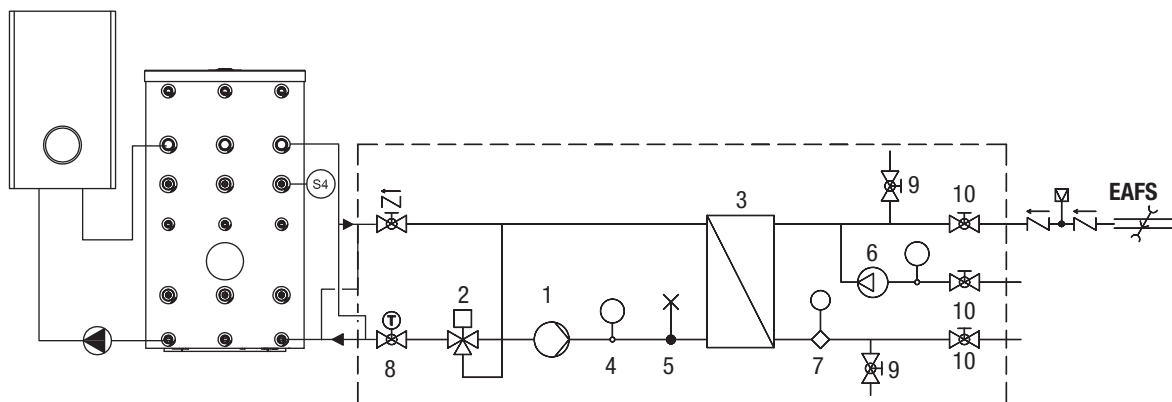

- |  |                                     |
|--|-------------------------------------|
| 1. Modulating primary circulation pump | 6. Recirculation kit                |
| 2. 3-way mixing valve with servomotor  | 7. Vortex flow sensor               |
| 3. Plate exchanger                     | 8. Ball valve DN25 with thermometer |
| 4. Pocket for sensor                   | 9. Load/unload valve                |
| 5. Manual air vent valve               | 10. Ball valve DN25                 |

Module for the production of domestic hot water SC ACS 80

### Chart on production of DHW

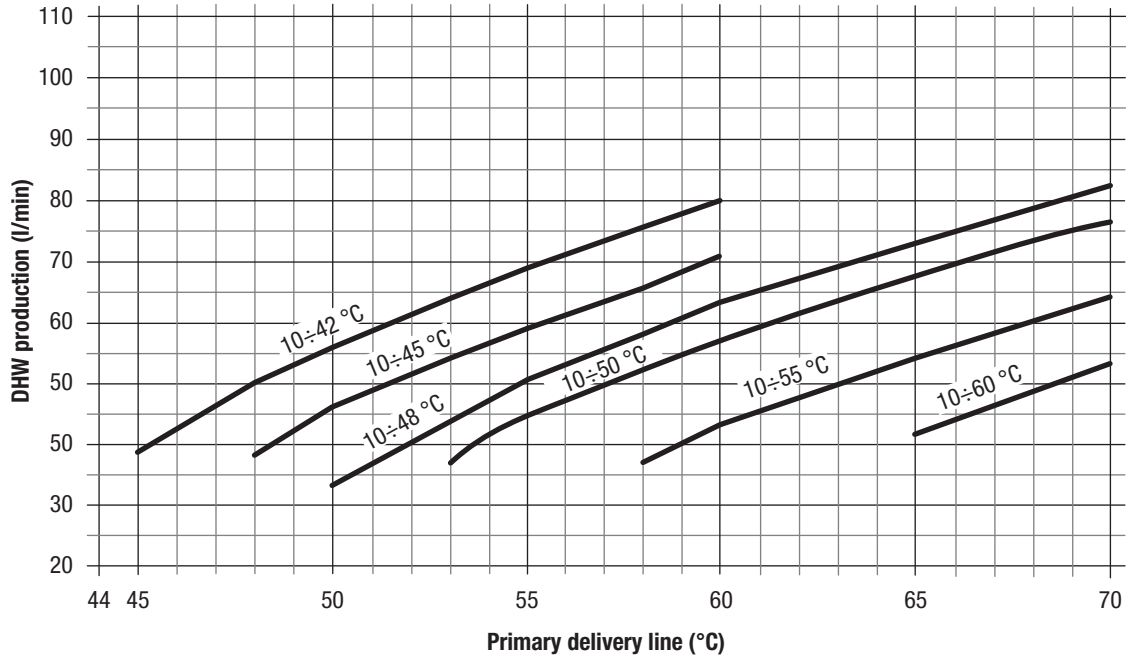

The correct operation of the module is guaranteed if the delivery temperature of the primary circuit is at least 5°C higher than the set DHW temperature.

### Circulation pump curves

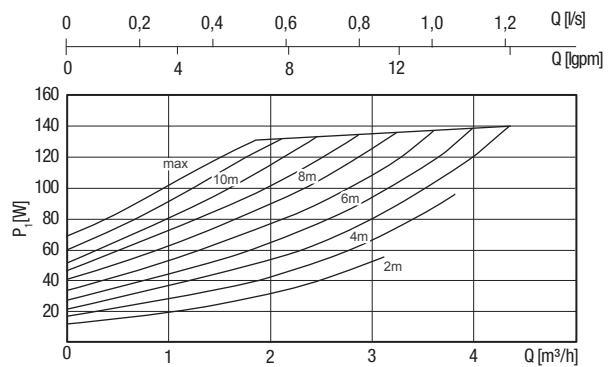
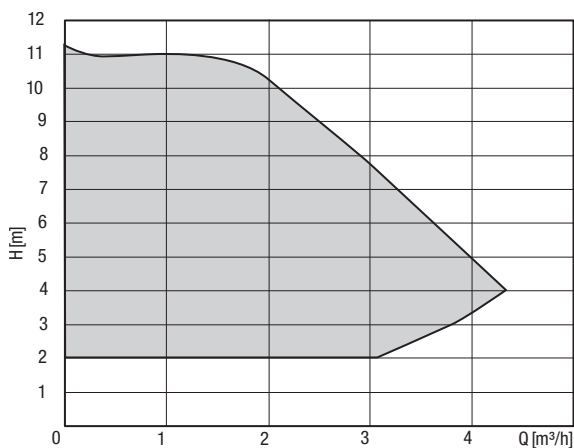

Module for the production of domestic hot water SC ACS 80

# Wiring diagram

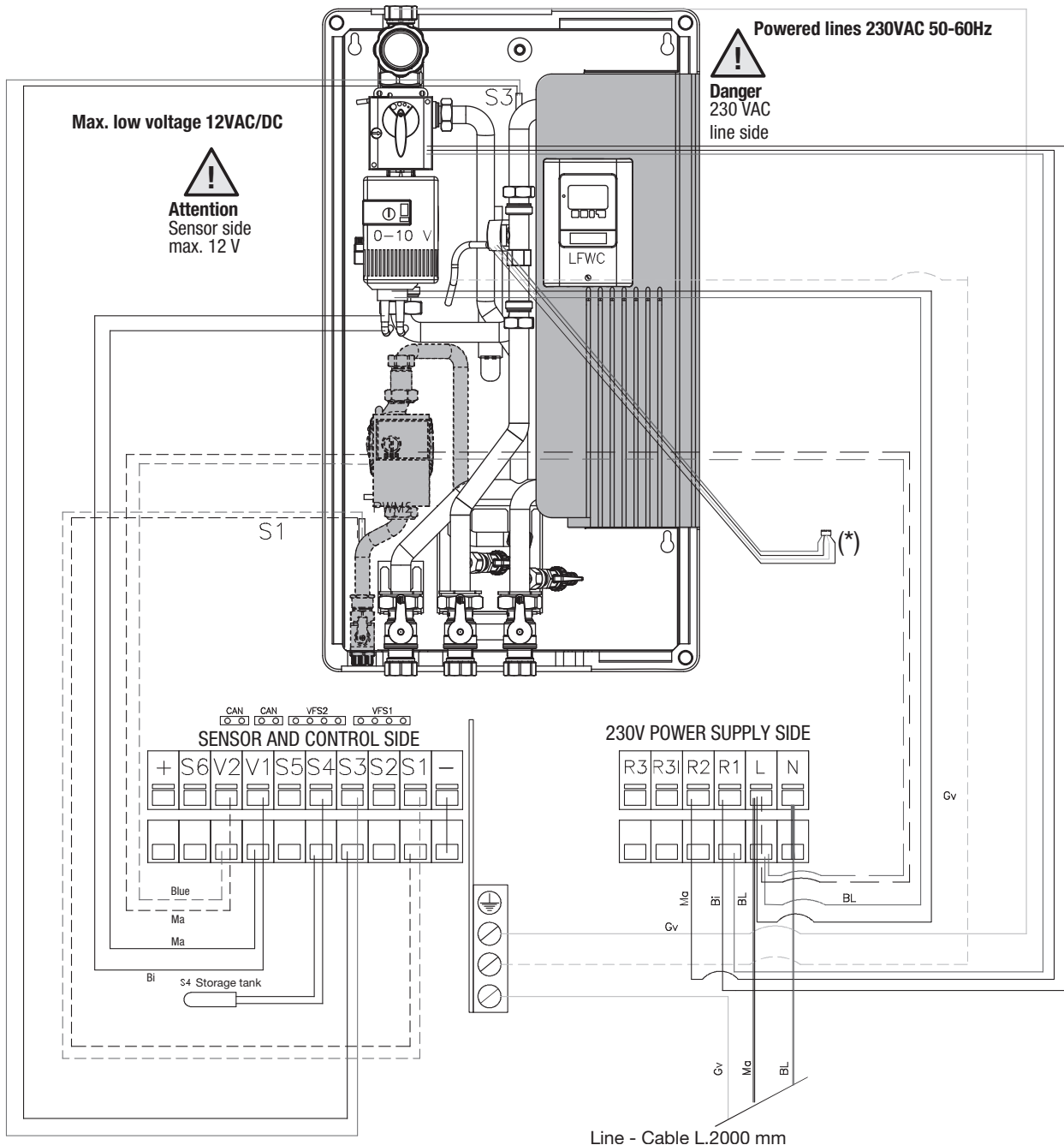

- V1 PWM1 primary circulation pump
- V2 iPWM2 recirculation circulation pump
- S1 PT1000 recirculation S1 (optional)
- S3 PT1000 primary S3
- S4 PT1000 storage system S4 high

- GND Earth
- MA Phase L / primary pump main line
- BL Neutral N / primary pump main line
- (\*) Insert terminal VFS1 in the control unit

## Module for the production of domestic hot water SC ACS 80

### Electrical wiring

It is mandatory:

- Have a differential magneto-thermal circuit breaker and a disconnecting switch compliant with the prevailing standards of the installation country.
- to comply with the connection L (phase) - N (Neutral); Ensure that the earth conductor is approx. 2 cm longer than power supply cables;
- Connect the device to an efficient earth system.

It is forbidden to use water pipes to earth the device.

It is forbidden to lay the power supply cables in the vicinity of any hot surfaces (delivery pipes). If there is a risk of contact with hot parts, with temperatures exceeding 50°C, a suitable type of cable must be utilized.

### Connection to the water mains

- For domestic hot water production systems, provide an impurity filter to protect the system. Provide a properly sized expansion vessel in order to avoid overpressure due to thermal expansion and water hammer.
- In the presence of water with hardness higher than 15 °Fr, it is advisable to install an adequate water treatment system at the inlet of the heating system, in order to avoid possible limescale caused by hard water or corrosion produced by aggressive water.
- It should be remembered that even a small build-up, just a few millimetres thick causes, because of its low thermal conductivity, a reduction in performance on the DHW side.
- The construction materials of the domestic hot water production module mod. SC ACS 80 comply with the provisions by the Ministerial Decree 174/2004, regulated by Directive 98/83/EC.
- Although the fittings are factory fitted, all screw connections must be checked and further tightened. It is also important to carry out a leak test (pressure test) during commissioning.
- Exceeding the values in the table on the side could result in damage to the DHW module and inevitably void the warranty, so we recommend a complete water analysis be carried out to show whether the values are within the limits indicated in the table.

Components	Units of measurement	Limit values for welded copper heat exchangers
PH		7-9 (considering the saturation index)
Saturation Index ( $\Delta$ PH)		$-0.2 < 0 < +0.2$
Total hardness	°Fr	7-15
Conductivity	$\mu$ S/cm	10... 500
Substances that can be filtered	mg/l	<30
Free chlorine	mg/l	<0.5
Hydrogen Sulphide	mg/l	<0.05
Ammonia	mg/l	<2
Hydrogen Carbonate	mg/l	<300
Hydrogen Carbonate/Sulphide	mg/l	>1.0
Sulphide	mg/l	<1
Nitrate	mg/l	<100
Nitrite	mg/l	<0.1
Sulphate	mg/l	<100
Manganese	mg/l	<0.1
Dissolved iron	mg/l	<0.2
Free aggressive carbon dioxide	mg/l	<20

### System diagram

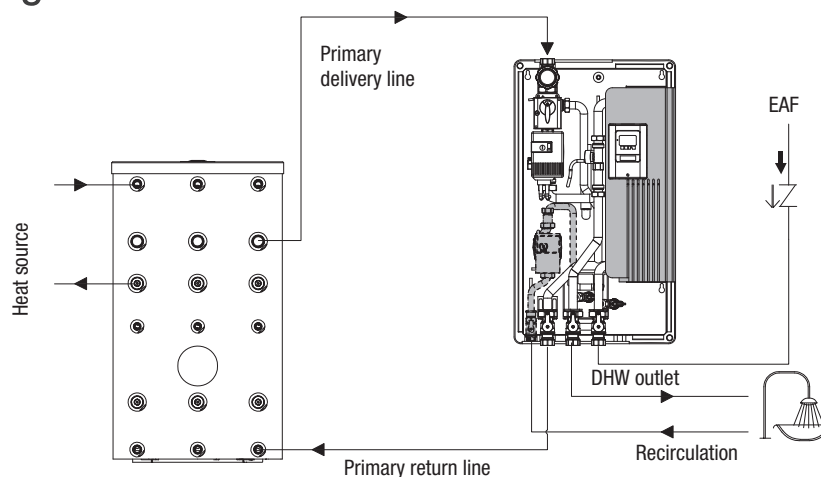

In case of recirculation, provide a properly sized expansion vessel in order to avoid overpressure due to thermal expansion and water hammer.

# Module for the production of domestic hot water

## SC ACS 160



- SC ACS 160 modules are modern systems for transferring heat from a thermal storage tank, for the production of high volumes of domestic hot water, through an AISI 316 brazed plate heat exchanger.
- The system is controlled by an electrical panel complete with solar regulator for the control and management of the functions of the system components. Each component is designed to also operate manually.
- The PRIMARY CIRCUIT of the heat exchanger is composed of:
  - 3-way mixing valve: to stabilise the inlet temperature.
  - No. 2 0-10 V modulating circulation pumps in parallel.
  - Acoustic/light alarm system – triggered in case of malfunction of one of the two circulating pumps.
  - Return diverter valve: it works on the return of two separate storage tanks or on a single storage tank for stratification management.
- The SECONDARY CIRCUIT of the heat exchanger, suitable for the production of domestic hot water, is composed of:
  - Electronic flowmeter for the temperature and volume control system of the produced DHW.
  - Recirculation pump: controlled at variable speed.

## Technical data

Description	Unit	SC ACS 160
DHW min-max flow rate	l/min	10÷200
DHW production T prim. 55°C - ΔT sec. 10÷45°C	l/min	100
DHW production T prim. 60°C - ΔT sec. 10÷45°C	l/min	135
DHW production T prim. 65°C - ΔT sec. 10÷45°C	l/min	165
Maximum output for primary side	l/h	8000
Maximum exchanged power	kW	403
Maximum output for secondary side	l/min	225
Maximum operating temperature	°C	90
Maximum operating pressure for primary side	bar	10
Maximum operating pressure for secondary side	bar	10
Absorbed electrical power	W	410
Power supply voltage	V	230
Electrical protection level	IP	40
Primary circuit circulation pumps		Wilco STRATOS PARA 25/1-8
Dimensions (w×h ×d)	mm	900×1000×500
Dimensions + package (w×h ×d)	mm	1050×1225×580

## Module for the production of domestic hot water SC ACS 160

### Structure

1. Cabinet with painted sheet metal frame, ventilation air intakes for internal electronic components, inspectionable on four sides
2. AISI 316 brazed plate heat exchanger

#### Primary circuit

3. Filter
4. Non-return valve
5. Mixing valve on the primary circuit with servomotor (220 V AC 3 points)
6. HIGH EFFICIENCY modulating circulation pumps installed in parallel (1) and (2)
7. Automatic bleeder valve
8. Double return diverter valve
9. Primary circuit shut-off ball valves
10. 1/2" M loading and unloading cock

#### Secondary circuit

11. Digital flow and temperature meter 5-100 l/min - 10-200 l/min
12. Filter
13. Water hammer protection ball valves
14. Circulating pump for recirculation function
15. Non-return valve

#### Electrical panel

16. Main switch; control unit

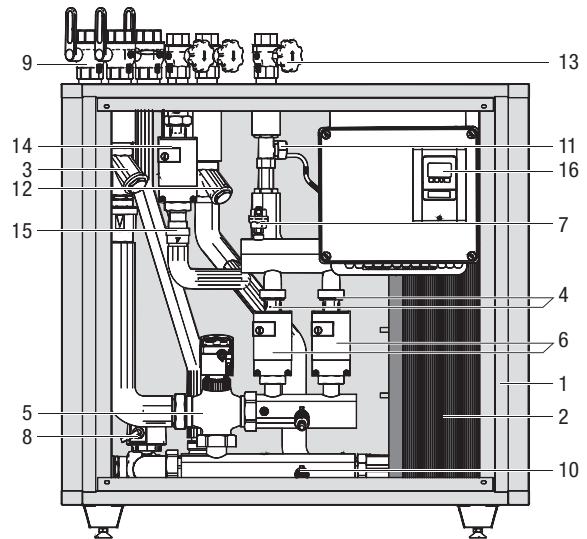

### Dimensions and couplings

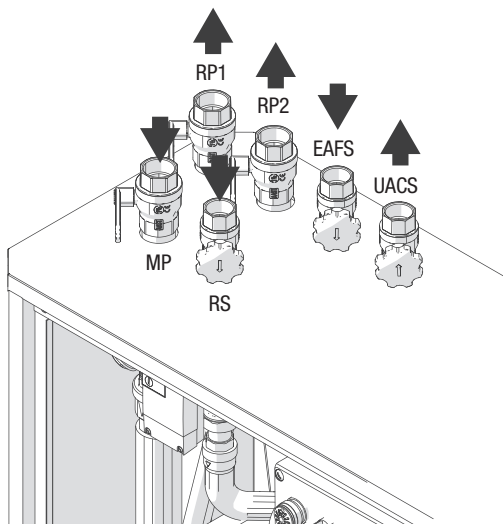

Description	SC ACS 160
RP1 Primary return 1 (lower storage tank)	1 1/2"
RP2 Primary return 1 (mid storage tank)	1 1/2"
MP Primary delivery line	1 1/2"
RS DHW recirculation	1 1/4"
EAFS Domestic hot water inlet	1 1/4"
UACS Domestic hot water outlet	1 1/4"

#### Dimensions:

Height with couplings 1100 mm

Width 1000 mm

Depth 500 mm

It is advisable to keep the area around the device at least 50 cm clear for easy inspection and maintenance of the device.

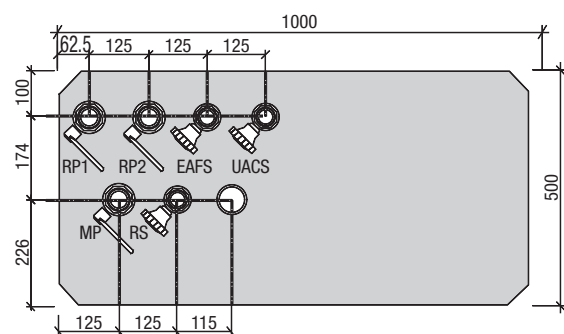



Module for the production of domestic hot water SC ACS 160

# DHW circuit pressure losses

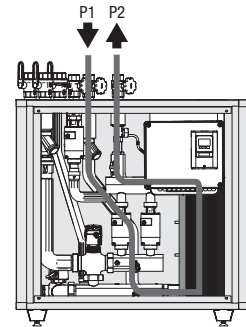
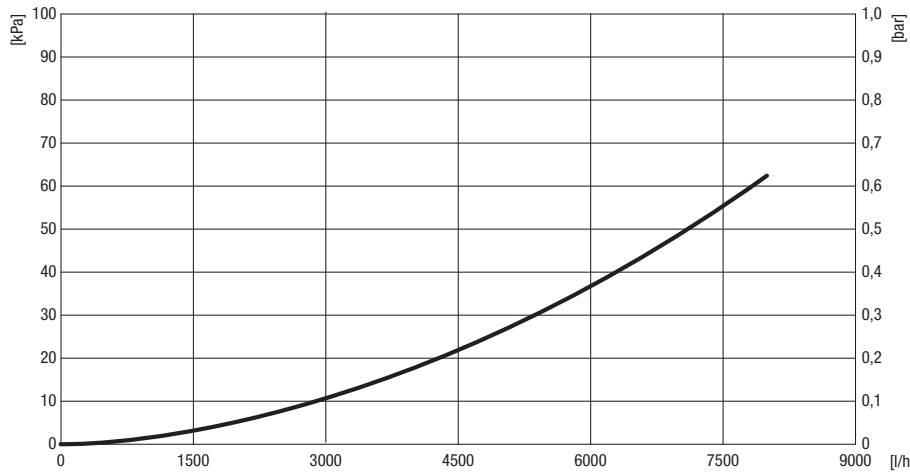

# Circulation pump head and recirculation circuit pressure losses

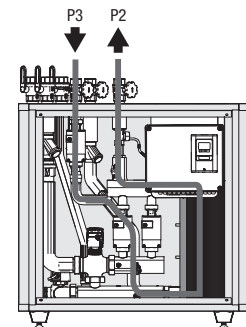
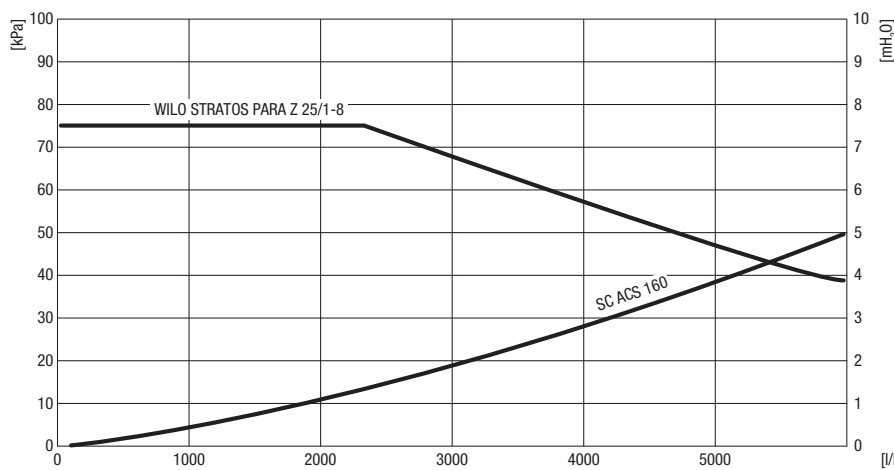

Module for the production of domestic hot water SC ACS 160

# Characteristic curves

## Primary circuit circulation pump

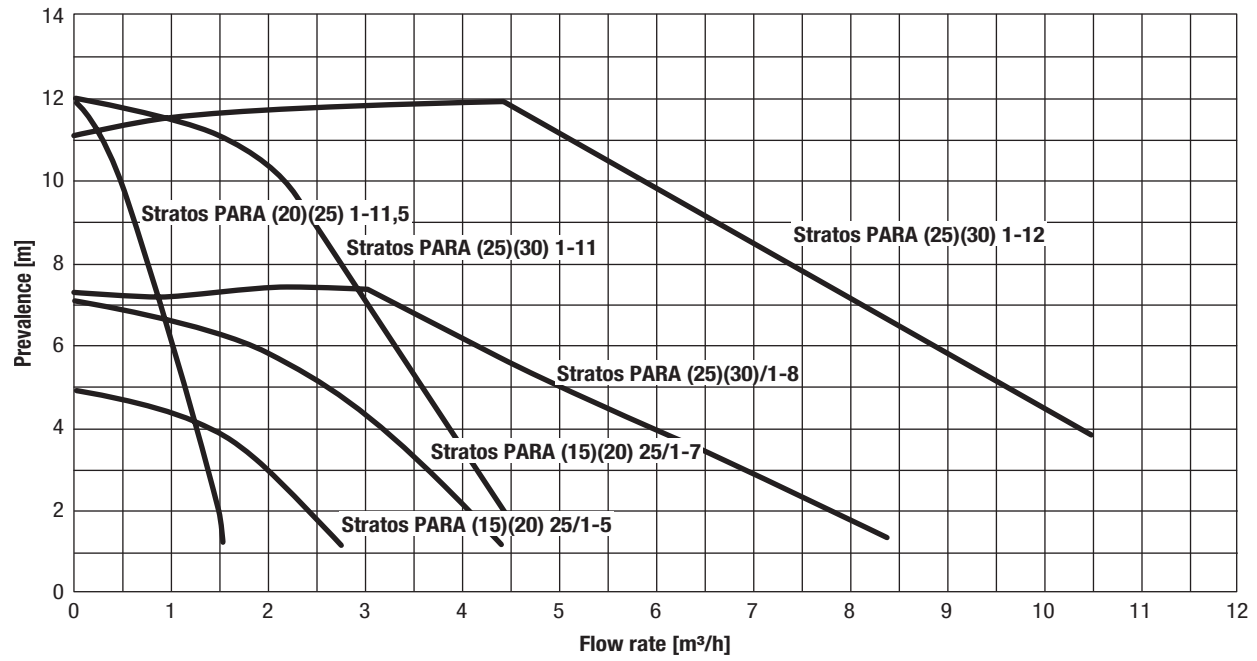

# Hydraulic connection

## Connection to the water mains

- In order to operate the module, the nominal values and the substances contained in the drinking water must be observed, as shown in the table.
- The specified values are indicative and may vary according to certain conditions of use.
- Exceeding the rated values may cause damage to the module and invalidate the warranty, therefore it is recommended to perform a full water analysis to determine if the values are below the limits specified in the table.

Components	Units of measurement	Limit values for welded copper heat exchangers
PH		7-9 (considering the saturation index)
Saturation Index ( $\Delta$ PH)		-0.2<0<+0.2
Total hardness	°Fr	15-30
Conductivity	$\mu$ S/cm	10... 500
Substances that can be filtered	mg/l	<30
Free chlorine	mg/l	<0.5
Hydrogen Sulphide	mg/l	<0.05
Ammonia	mg/l	<2
Hydrogen Carbonate	mg/l	<300
Hydrogen Carbonate/Sulphide	mg/l	>1.0
Sulphide	mg/l	<1
Nitrate	mg/l	<100
Nitrite	mg/l	<0.1
Sulphate	mg/l	<100
Manganese	mg/l	<0.1
Dissolved iron	mg/l	<0.2
Free aggressive carbon dioxide	mg/l	<20

Module for the production of domestic hot water SC ACS 160

# System diagram

## Variant with single return

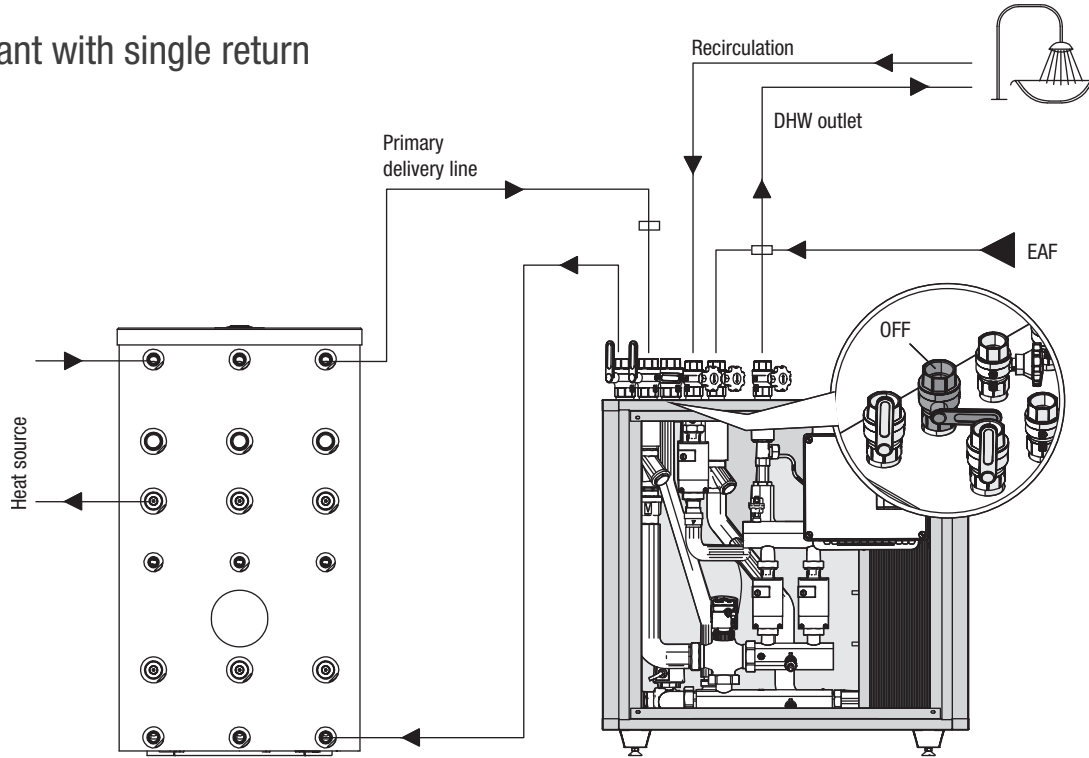

## Variant with double return

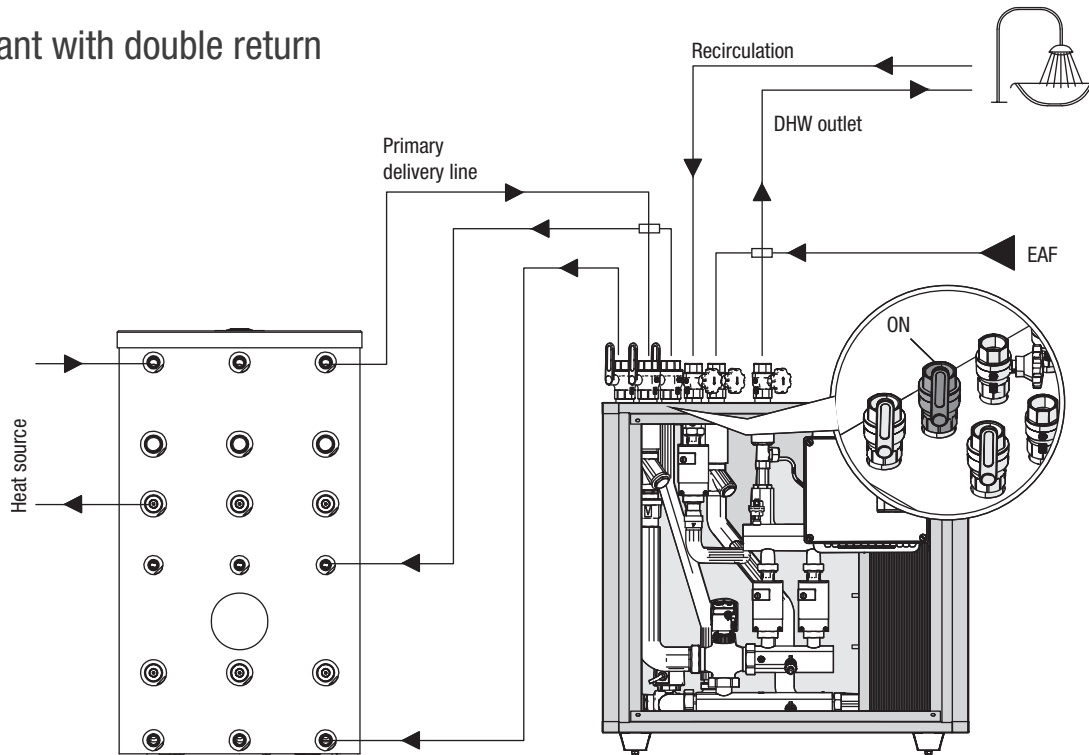

## Module for the production of domestic hot water SC ACS 160

### Control unit

The DHW control unit allows efficient use and control of the operation of your domestic hot water system. The smart management of 2 circulation pumps in parallel allows the optimisation of consumption and ensures a device performance of 60%, compared to its size, even in case of malfunction or failure of one of the primary circulation pumps:

- During DHW withdrawal, when the first circulation pump is switched on, if the required flow rate is not met, the control unit activates the second circulation pump, thus ensuring a greater flow rate in order to satisfy the user's request. This also occurs in the event that the set DHW temperature is not reached within 5 seconds of the circulation pump being switched on.
- In the event that the demand for DHW rapidly decreases, the control unit will turn off the second circulation pump to avoid unnecessary waste of energy and better control of the delivery temperature.
- It is also possible to set a curve for the primary circuit, by means of relevant parameters (default values  $T_{\min}$  48°C -  $T_{\max}$  60°C), in order to really meet the instant demand for hot water and avoid useless heat losses, as in the case of fixed point mixing.

At the time of delivery of the product, all the above parameters have default values set at the factory; these parameters can be reset by a qualified technician, depending on the request of the user. The control unit stands out for its functional and simple use, almost "self-explanatory". For each programming point, the data is associated with certain functions with additional explanations. The menu of the control unit contains keywords for settings and measured values, but also help texts and graphs.

#### Main characteristics

- 0 - 10 V output for pump speed control.
- Description of graphs and texts on the display.
- Simple control of measured current values.
- Analysis and monitoring of the system through statistical graphs, etc.
- Extensive setting menus with explanations.
- The menu lock can be activated to prevent unwanted changes.



### Technical Specifications

Electrical Specifications	
Voltage	230 VAC $\pm$ 10%
Frequency	50 $\div$ 60 Hz
Current consumption	2 VA
Power contacts:	
total	460 VA (outputs 1-4)
per relay	460 VA for AC1 / 185 W for AC3
outlet pump speed control	0-10 V, internal heating element 10 k $\Omega$
Internal fuse	2 A slow-blow 250 V
Protection level	IP40
Protection class	II
Inlet sensors	4 $\times$ PT1000 + 1 $\times$ Vortex flow sensor (VFS)
Temperature sensors	
Immersion sensor	PT1000, e.g. TT/P4 up to 95 °C
Tube sensor	PT1000, e.g. TR/P4 up to 95 °C
Vortex flow sensor	return flow and temperature detection
Sensor distance	PT1000: 2 $\times$ 1 mm <sup>2</sup> up to 30 m max.
Max. Vortex sensor length	extendable up to 3 m max.

### Temperature resistance table for PT1000 sensors

Resistance [ $\Omega$ ]	1000	1039	1077	1116	1155	1194	1232	1270	1308	1347	1385
Temperature [°C]	0	10	20	30	40	50	60	70	80	90	100

## Module for the production of domestic hot water SC ACS 160

# Key functions

## Recirculation

When the "Request" mode is active, the recirculation pump will be activated after a water withdrawal and remain active until the target recirculation temperature (recirculation T<sub>min</sub> + hysteresis) is reached at the recirculation sensor.

In "Time" mode, the circulation pump is active during the set times and when the set minimum circulation temperature is not reached and remains on until the required circulation temperature (recirculation T<sub>min</sub> + hysteresis) is reached at the circulation sensor. Request+Time: The circulation pump is active during the enabled times and when the temperature is below the set minimum recirculation one or when there is water withdrawal.

The recirculation remains active until the required recirculation temperature (recirculation T<sub>min</sub> + hysteresis) is reached at the recirculation sensor.

Always on: The recirculation pump is switched on at the set times.

### Recirculation T<sub>min</sub> = minimum temperature of sensor S1

If the temperature drops below recirculation T<sub>min</sub> and the circulation is active, the pump is activated.

Setting range: 10 °C to 85 °C

### Recirculation hysteresis = Disable recirculation pump shut-off hysteresis

If the temperature exceeds T<sub>min</sub> S1 the pump is switched off.

Parameter range: 1-20K

### Maximum recirculation flow rate = maximum recirculation pump flow rate

If the flow rate measured at sensor 6 exceeds this value, the recirculation pump is switched off.

Parameter range: 1-50 l/min.

### Recirculation time = sets the operating times of the pump

You can set 3 different times for each day of the week, you can then copy them to the other days.

Out of the defined timeframes, recirculation is not active. The set times are only used in the "Time" recirculation mode.

### Withdrawal support

To ensure a constant temperature even with small withdrawals, the recirculation pump can be used as a backup pump.

The pump is activated not only under normal conditions, but also with small withdrawals.

When a storage sensor is connected, the withdrawal support is activated when the storage T<sub>min</sub> is reached at the storage sensor.

### Minimum storage temperature

The withdrawal support is deactivated when the storage temperature falls below the "minimum storage temperature".

### Withdrawal support measurement

See "F3. - Calibration".

## Storage stratification

The storage stratification function starts a valve that brings the return in the central or lower part of the storage tank, depending on the temperature. Use this menu to set the temperature difference between return and storage. If the return temperature exceeds the storage temperature by the value set here, the central part of the storage tank is loaded.

If no storage sensor is connected, a storage temperature of 25 °C is set.

## Comfort

With the comfort function active, the heat exchanger is fed by the primary circuit pump for 5 seconds every 15 minutes, so that the hot water is made available as quickly as possible when it is drawn off.

## Anti-legionella

With the AL function activated, the MFWC control unit makes it possible to heat the lines and the storage tank at selectable times (AL Time) for the set time (AL time required), until the required AL Tset temperature is reached.

The temperature measured on the S4 has as a reference Tset AL + 5 °C. When the AL function is active, T<sub>max</sub> is set to AL Tset + 10 °C to prevent the system from shutting down due to high temperature. The AL function ends only when a temperature of at least "AL Tset - 5 °C" is reached on the hot water sensor and, if present, on the recirculation sensor for the time set in "AL required time". The display shows "Last heating AL". If AL is not completed after 2 hours, the attempt will be cancelled and an error message will appear.

## Limescale protection

To prevent limescale build-up, the circulation pump can continue to feed the heat exchanger for 5÷30 seconds after a withdrawal until the water temperature falls below the value set for the recirculation.

## Automatic Setpoint adjustment

This function is used if the necessary temperature in the primary circuit is not always guaranteed.

With this function activated:

When the storage sensor is not connected:

If the setpoint temperature is not reached after 60 seconds, the -3 °C temperature is used as the new setpoint. Once the pump in the primary circuit stops, the setpoint temperature is raised again up to Tset.

When the storage sensor is connected:

if the temperature at the storage sensor is lower than Tset - 5 °C, the desired temperature is lowered to - 5 °C.

In both cases " T<sub>min</sub> recirculation" is decreased to the new setpoint temperature - recirculation hysteresis - 5°C, where "T<sub>min</sub> recirculation" is not lower than 0°C and not higher than T<sub>min</sub> recirculation setpoint.

## Anti-jam protection

If the anti-jam function is active, the control unit will activate the relay and connected components every day at 12:00 noon ("daily" setting) or weekly every Sunday at 12:00 noon ("weekly" setting) for 5 seconds to prevent the pump and/or valve from blocking after a long period of inactivity.

## Module for solar circuit SC SUN 50



- SC SUN 50 is a separation module with plate heat exchanger that is used for the supply of energy to two thermal storage tanks (puffers) or to two different loading heights of a single storage tank (puffer) solar thermal system with collectors in series.
- The electronic control system provides for the speed control (with 0-10 V function) of the high-efficiency circulation pump of the primary circuit, thus ensuring an optimal use and management of energy.
- The secondary circuit is equipped with an electronic flow meter for displaying the flow rate and metering the amount of heat exchanged.
- SC SUN 50, complete with thermal insulation, is pre-wired, tested and ready to use.

### Technical data

Description	Unit	SC SUN 50
Exchanged thermal output	kW	32
Maximum output for primary side	l/h	1500
Maximum output for secondary side	l/min	19.2
Primary circuit DT	°C	20.0
DT between primary inlet/secondary outlet	°C	4.0

Description	Unit	SC SUN 50
Collector surface	m <sup>2</sup>	50
Minimum allowed temperature	°C	2
Maximum operating temperature	°C	110
Maximum operating pressure for primary side	bar	10
Primary non-return valve opening pressure	mbar	45
Secondary non-return valve opening pressure	mbar	20
Primary circulation pump absorbed power (max/stand-by)	W	38 / 1
Secondary circulation pump absorbed power (max/stand-by)	W	23 / 1
Solar control unit absorbed power (stand-by)	W	0.5
Solar control unit energy efficiency	%	1
Power supply voltage	V	230
Power supply frequency	Hz	50-60
Electrical protection level	IP	40
Net weight	kg	22.8
Water volume	l	6.8

**Module for solar circuit SC SUN 50**

# Structure

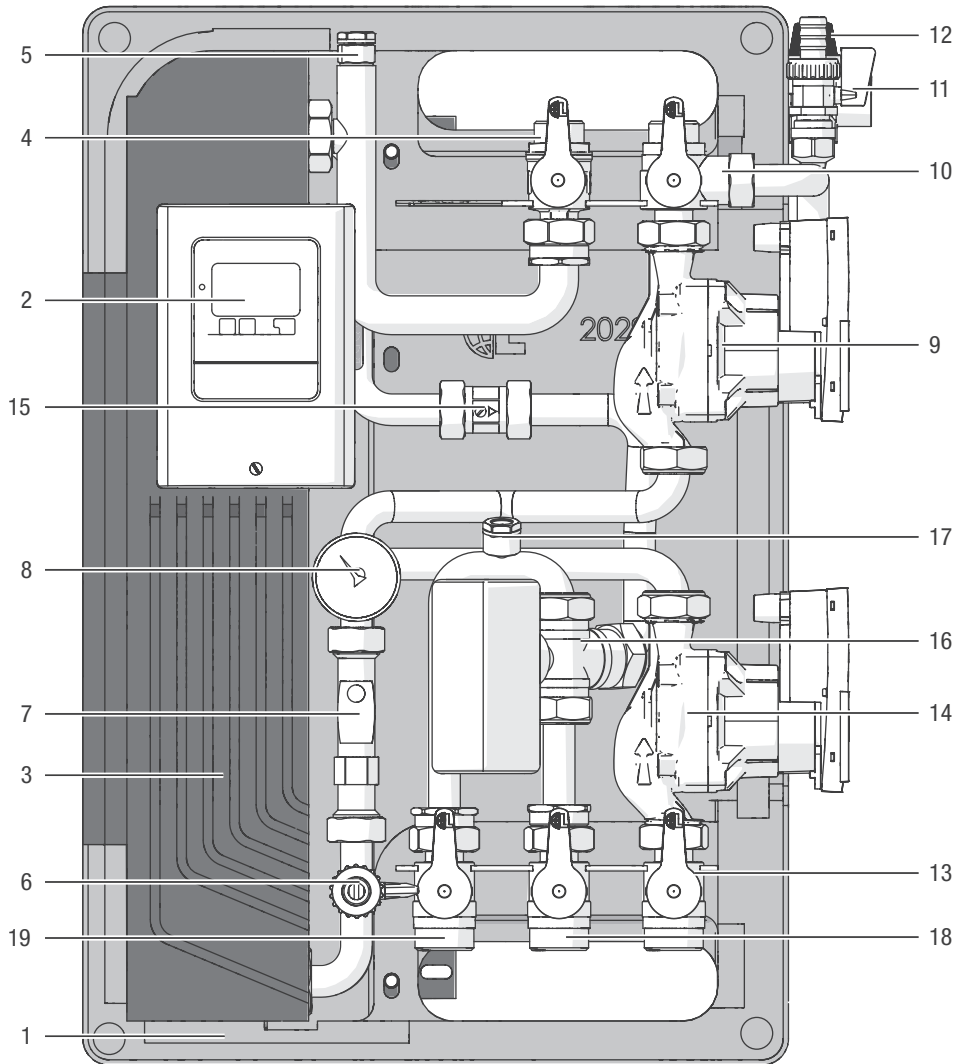

- PRIMARY SIDE**
1. EPP insulation
  2. Electronic regulator
  3. Exchanger
  4. Primary delivery ball valve
  5. Breather valve
  6. Load/unload valve
  7. Flowmeter with temperature gauge
  8. Pressure gauge
  9. Circulation pump
  10. Primary return 3-way valve
  11. Solar system loading/unloading valve
  12. Safety valve

- SECONDARY SIDE**
13. Secondary delivery valve
  14. Circulation pump
  15. Non-return valve
  16. Motorised diverting valve
  17. Breather valve
  18. Return valve for storage tank 1
  19. Return valve for storage tank 2

Module for solar circuit SC SUN 50

# Dimensions and couplings

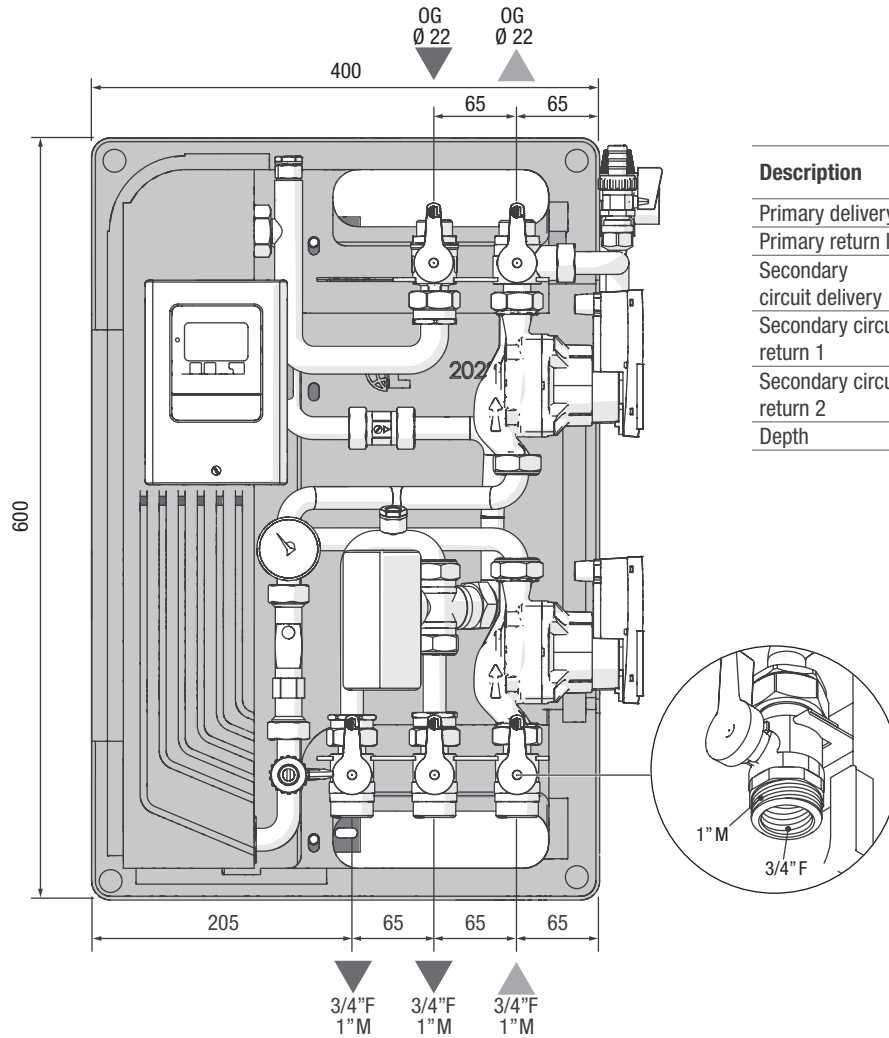

Description	SC SUN 50
Primary delivery line	Ø 22 mm pipe ogive connection
Primary return line	Ø 22 mm pipe ogive connection
Secondary circuit delivery	1" M - 3/4" F
Secondary circuit return 1	1" M - 3/4" F
Secondary circuit return 2	1" M - 3/4" F
Depth	260 mm

# Hydraulic circuit

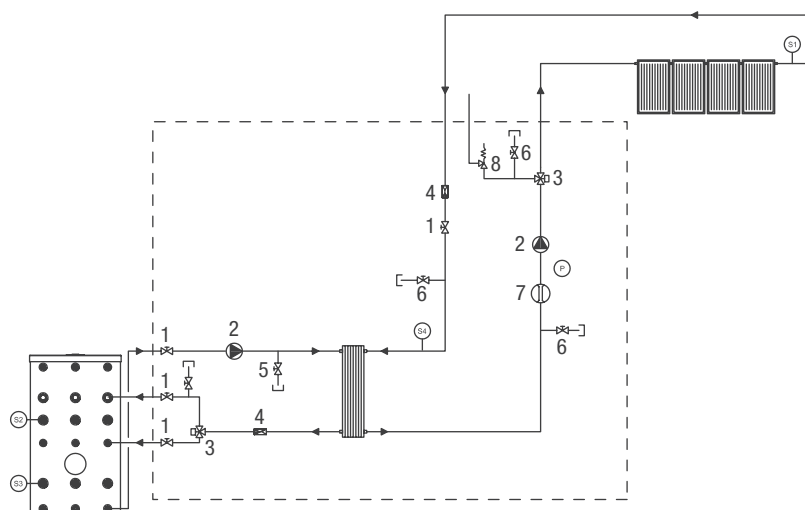

1. 2-way valve
2. Circulation pump
3. 3-way diverting valve
4. Non-return valve
5. Cock with cap
6. Manual bleeder valve
7. Flowmeter with temperature gauge
8. Solar safety valve

Module for solar circuit SC SUN 50

# (Solar) Primary circuit pressure drops

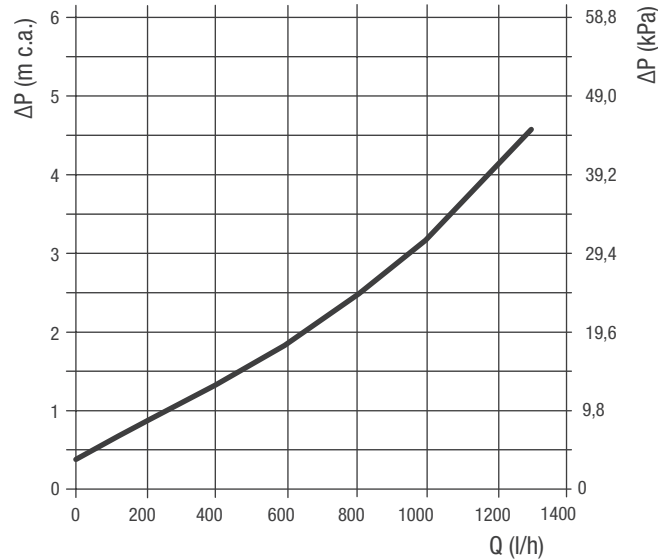

To obtain the useful head, subtract the pressure drop value from the head value read in the solar circulation pump diagram below.

# Circulation pump curves

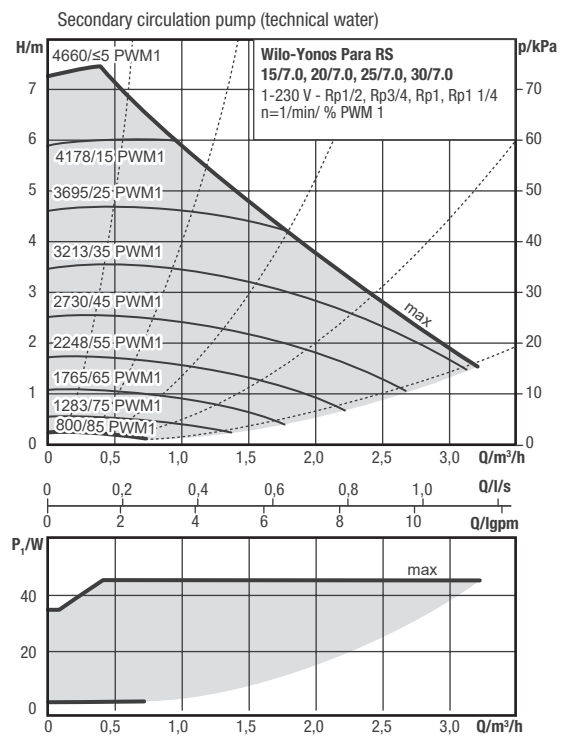
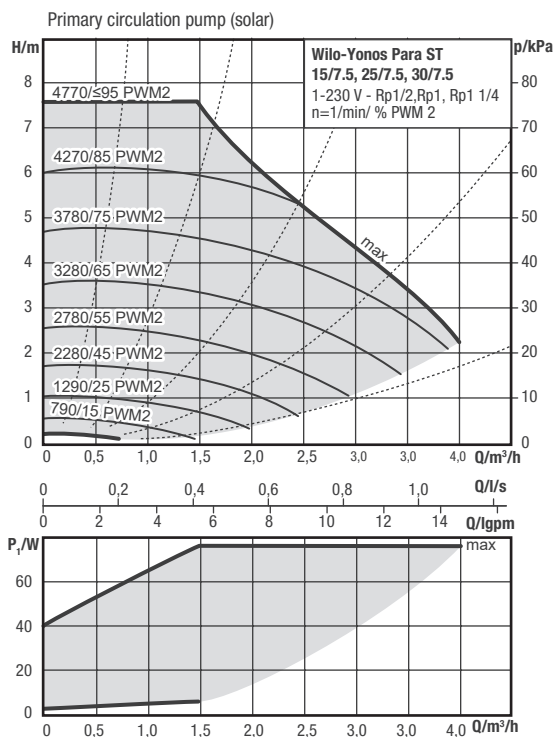

The correct operation of the module is guaranteed if the delivery temperature of the primary circuit is at least 5K higher than the set storage temperature.

Module for solar circuit SC SUN 50

# Wiring diagram

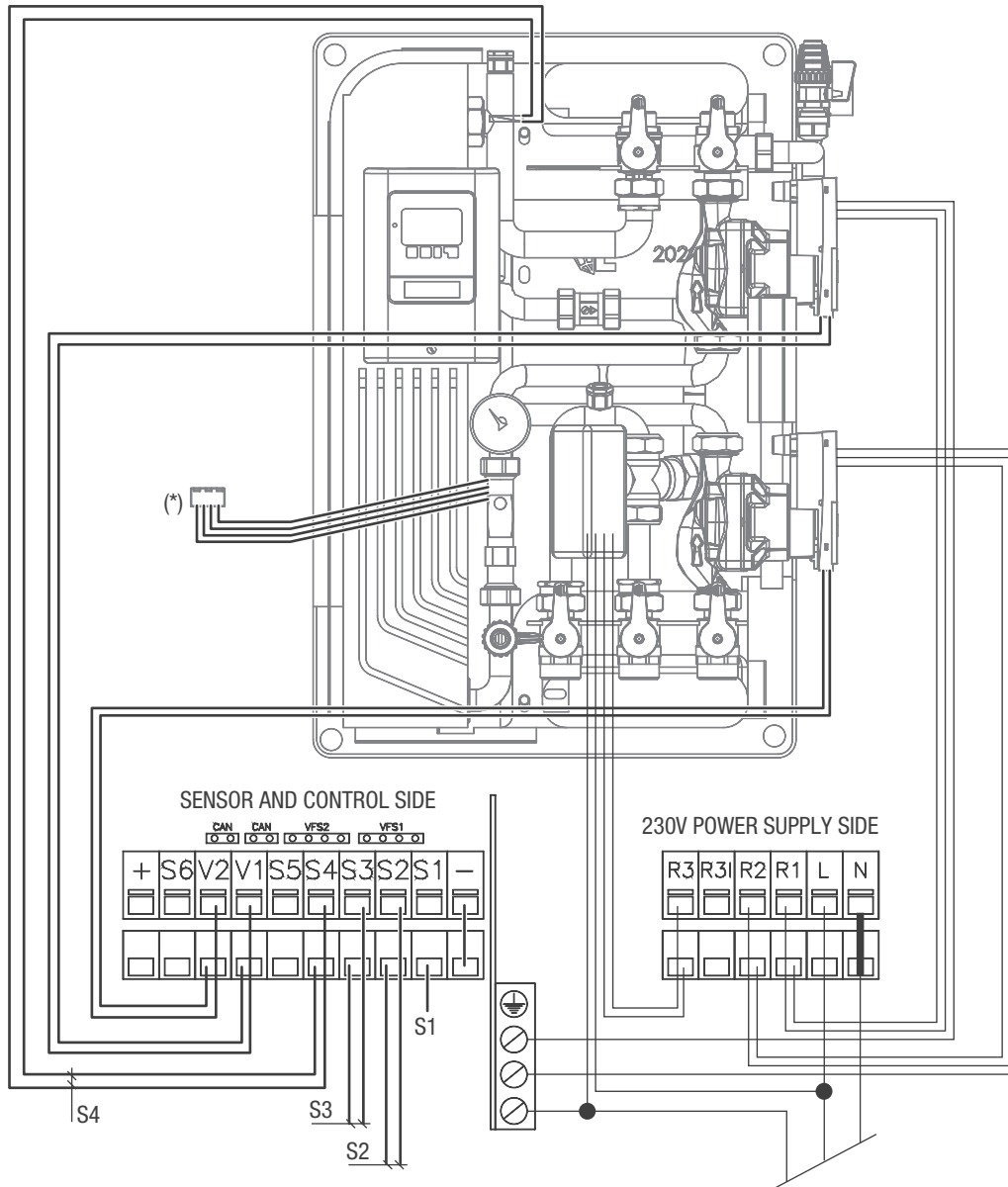

- S1 Solar collector sensor; wire in control unit
- S2 Upper storage sensor/1
- S3 Lower storage sensor/2
- S4 Primary delivery sensor
- (\*) Insert terminal VFS2 in the control unit

The control unit works with Pt 1000 temperature sensors that guarantee an accurate measurement and therefore an optimal use of the system functions.

The temperature sensor cables must be laid separately from the electrical cables and must not, for example, be placed in the same pipe.

The cable of the S1 sensor is supplied as standard with a length of 2 metres.

S1 and S5 sensor cables can be extended up to 30 m using a cable of at least 2x1 mm<sup>2</sup>. S2, S3, S4 and S6 sensor cables can be extended up to 10 m using a cable of at least 2x0.75 mm<sup>2</sup>.

Module for solar circuit SC SUN 50

# System diagram

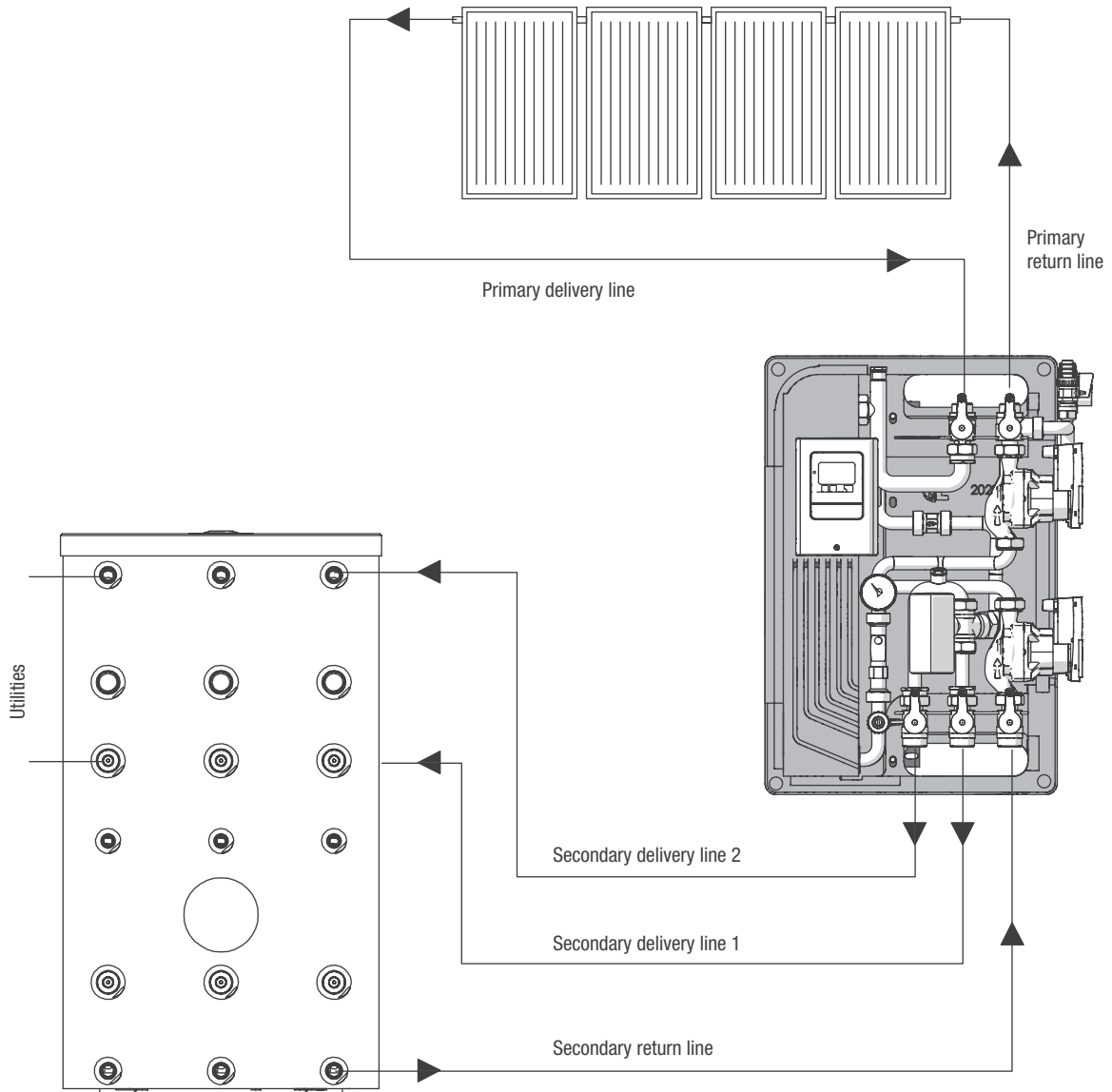

The module must be positioned near the storage tank. The system is dimensioned for a length of the connection pipes between the module and the storage tank of 4 meters (flow + return).

## Module for solar circuit SC SUN 50

### Control unit

The LTDC4 differential control unit allows efficient use and control of the operation of the solar or heating system. The control unit stands out for its functional and simple use, almost "self-explanatory". For each programming point, the data is associated with certain functions with additional explanations. The menu of the control unit contains keywords for settings and measured values, but also help texts and graphs. The LTDC4 can be used as a differential temperature control unit for various system variants. At the time of delivery of the product, all the above parameters have default values set at the factory; these parameters can be reset by a qualified technician, depending on the request of the user. The menu of the control unit contains keywords for settings and measured values, but also help texts and graphs.

Main features of the LTDC4:

- Displaying of graphs and texts on the display.
- Simple control of measured current values.
- Analysis and monitoring of the system through statistical graphs, etc.
- Extensive setting menus with explanations.
- PWM and 0-10V output.
- The menu lock can be activated to prevent unwanted changes.
- Function to restore previous values or factory settings.
- Wide range of additional functions.



### Disposal

The control unit complies with the European RoHS Directive 2002/95/EC which concerns restrictions on the use of certain substances in electrical and electronic equipment.

### Technical Specifications

Electrical Specifications	
Voltage	230 VAC $\pm$ 10%
Frequency	50 $\div$ 60 Hz
Current consumption	2 VA
Contact power	
electronic relay R1	min. 5 W / max. 120 W for AC3
electronic relay R2	min. 5 W / max. 120 W for AC3
mechanical relay R3	460 VA for AC1 / 185 W for AC3
PMV outlet	for working resistance 10 k $\Omega$
Internal fuse	2 A slow-blow 250 V
Protection level	IP40
Protection class	II
Inlet sensors	6 $\times$ PT1000 + 2 $\times$ Vortex flow sensor (VFS)
Measurement range	PT1000 -40 $^{\circ}$ C up to 300 $^{\circ}$ C
Vortex sensor	0 $^{\circ}$ C to 100 $^{\circ}$ C (-25 $^{\circ}$ C / 120 $^{\circ}$ C short time) 1 - 12 l/min (VFS1-12) / 2 - 40 l/min (VFS2-40) / 5 - 100 l/min (VFS5-100) / 10 - 200 l/min (VFS10-200)
Allowed climatic conditions	
Ambient temperature:	
for control unit operation	0 $^{\circ}$ C $\div$ 40 $^{\circ}$ C
for transport/storage	0 $^{\circ}$ C $\div$ 60 $^{\circ}$ C
Air humidity:	
for control unit operation	max. 85% relative humidity with 25 $^{\circ}$ C
for transport/storage	no moisture condensation allowed
Other specifications and dimensions	
Enclosure	3 Parts, ABS Plastic
External dimensions	163 mm $\times$ 110 mm $\times$ 52 mm
Opening dimensions for installation	157 mm $\times$ 106 mm $\times$ 31 mm
Display	large graphic display, 128 $\times$ 128 points
LED	multicolour green/red
Programming	4 buttons
Temperature sensors	
Collector or boiler sensor	PT1000, e.g. TT/S2 up to 180 $^{\circ}$ C
Storage sensor	PT1000, e.g. TR/P4 up to 95 $^{\circ}$ C
Contact sensor	PT1000, e.g. contact sensor TR/P4 up to 95 $^{\circ}$ C
Sensor distance	PT1000: 2 $\times$ 1 mm $^2$ up to 30 m max.

### Temperature resistance table for PT1000 sensors

Resistance [ $\Omega$ ]	1000	1039	1077	1116	1155	1194	1232	1270	1308	1347	1385
Temperature [ $^{\circ}$ C]	0	10	20	30	40	50	60	70	80	90	100

**Module for solar circuit SC SUN 50**

**Hydraulic variants**

The diagrams that can be set for the STS 120 module are number 26 and number 27, shown in the images below.

Layout 26

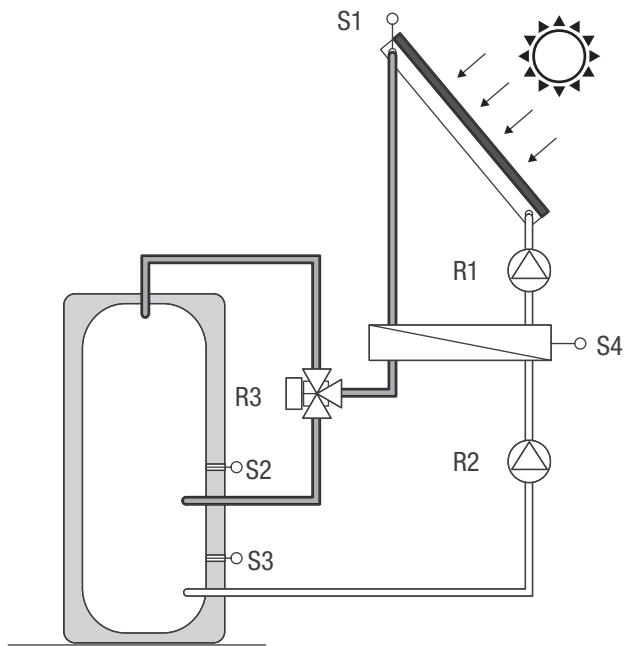

- S1 Manifold
- S2 Upper storage
- S3 Lower storage
- S4 Exchanger
- R1 Solar pump
- R2 Secondary pump
- R3 Diverting valve

Layout 27

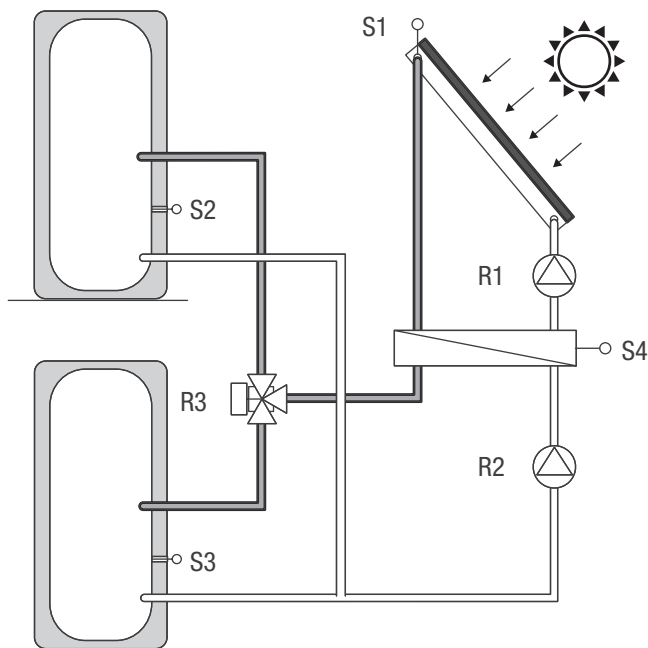

- S1 Manifold
- S2 Storage 1
- S3 Storage 2
- S4 Exchanger
- R1 Solar pump
- R2 Secondary pump
- R3 Diverting valve

## Module for solar circuit SC SUN 50

# Key functions

## Settings

### Tmin sensor (S1) = Enable/start temperature on sensor S1:

If this value is exceeded on sensor S1 and the other conditions also occur, the control unit drives the associated pump and/or valve. If the temperature at the sensor drops 5°C below this value, the control unit stops the pump and/or valve again.

### Storage 1 priority

Determines the order in which the storage tanks are filled. If the same priority is set for the two storage tanks, the load is not switched off until the active storage tank can no longer be charged.

### $\Delta T$ on storage 1 = Temperature differential for storage 1 loading:

If the temperature difference between the reference sensors is exceeded and the other conditions are also met, the control unit switches on the connected relay. If the temperature drops below  $\Delta T$  Off, the relay switches off.

If the set temperature differential is too low, the control unit may not function effectively, depending on the system and the position of the sensors. Special on/off functions can be added to control speed.

### Tmax sensor (S2) = Switch-off temperature on sensor S2

If this value is exceeded on sensor S2, the control unit stops the associated pump and/or valve. If the temperature drops below this value again and the other conditions also occur, the control unit will operate the associated pump and/or valve again.

### Storage 1 priority

Determines the order in which the storage tanks are filled. If the same priority is set for the two storage tanks, the load is not switched off until the active storage tank can no longer be charged.

### $\Delta T$ on storage 2 = Temperature differential for storage 2 loading

If the temperature difference between the reference sensors is exceeded and the other conditions are also met, the control unit switches on the connected relay. If the temperature drops below  $\Delta T$  Off, the relay switches off.

If the set temperature differential is too low, the control unit may not function effectively, depending on the system and the position of the sensors.

### Tmax sensor S3 = Switch-off temperature on sensor S3

If this value is exceeded on sensor S3, the control unit stops the associated pump and/or valve. If the temperature drops below this value again and the other conditions also occur, the control unit will operate the associated pump and/or valve again.

### T-priority = Temperature level for absolute priority

In systems with several storage tanks, the lowest priority storage tank is only loaded after the temperature limit set on the highest priority storage sensor has been exceeded.

### Load time = Load interruption in the storage tank having lower priority

The lowest priority storage tank loading is interrupted after a certain time (which can be set) to check if the collector has reached the temperature level required to start loading the lowest priority storage tank. If this is the case, the priority storage tank is loaded. If this is not the case, the increment is measured (see section "4.16. - Increase") to check if it is possible to load the priority storage tank in a short time.

### Increase = Extension of loading pause due to temperature increase in the collector

In order to allow a precise setting of the load priorities of systems with more than one storage tank, in this menu the temperature increase of the collector must be set so that the load interruption of the storage tank with the lowest priority is prolonged by one minute. The interruption is prolonged because it is expected that the increase in the temperature of the collector can quickly load the storage tank having lower priority.

As soon as the  $\Delta t$  conditions are reached, the priority storage tank is loaded. If the temperature increase is lower than the set value, the lowest priority storage tank loading will be activated again.

## Protection functions

### System protection

The protection system prevents overheating of the system components by automatically switching off the solar pump. If the value "Sys. prot. on" is exceeded on the collector for 1 minute, the pump will switch off and remain switched off. The pump is reactivated when the temperature drops below "Sys. prot. off".

### Collector protection

Collector protection prevents overheating of the collector. The pump is switched on to transfer heat from the collector to the storage tank. If the value "Coll. prot. on" is exceeded on the collector sensor, the pump is activated when the temperature "Coll. prot. off" or "PC Tmax Storage" in the storage tank or pool is exceeded.

If the collector protection is active and both storage tank and pool are present, the storage tank is heated up to the level "PC storage tank S(x) Max" above Tmax S2. If only one pool is used, the pool is not used for collector protection.

The protection of the system has higher priority than the protection of the collector. Even when the conditions to activate the collector protection are present, the solar pump is switched off when reaching the temp. "Prot.Coll.On."

### Cooling

In the hydraulic variants with solar system when the cooling function is activated, the excess energy of the storage tank is returned to the collector. This only happens if the temperature in the storage tank is higher than the "Cooling Tset" value and the collector is at least 20°C colder than the storage tank and therefore the storage

## Module for solar circuit SC SUN 50

temperature has dropped below the "Cooling Tset" value. In systems with two storage tanks, the setting applies to both storage tanks.

When the cooling function is active, there is energy loss through the collector! Cooling should only be active in periods with low heating demand, e.g. during long absence/holidays.

### Antifreeze

You can activate a frost protection/antifreeze function on two levels. In level 1 the control unit activates the pump for one minute every hour if the temperature of the collector drops below the set value of "Antifreeze level 1". If the collector temperature falls below the set value of "Antifreeze level 2", the control unit continuously activates the pump. If the collector temperature exceeds the "Antifreeze level 2" value by 2°C, the pump switches off again.

This function leads to a loss of energy through the collector! Normally not activated for solar systems with antifreeze. Observe the operating instructions for the other system components!

### Anti-jam protection

If the anti-jam function is active, the control unit will activate the relay and connected components every day at 12:00 noon ("daily" setting) or weekly every Sunday at 12:00 noon ("weekly" setting) for 5 seconds to prevent the pump and/or valve from blocking after a long period of inactivity.

## Module for solar circuit SC SUN 120 - 120 ACS



- SC SUN 120 and SC SUN 120 ACS are respectively a separation module and a domestic hot water production module, both with plate heat exchanger, that are used for the supply of energy to two thermal storage tanks (puffers) or to two different loading heights of a single storage tank (puffer), exploiting a solar thermal system with collectors in series.
- The electronic control system provides for the speed control (with 0-10 V function) of the high-efficiency circulation pump of the primary circuit, thus ensuring an optimal use and management of energy.
- The secondary circuit of both modules is equipped with an electronic flow meter to display the flow rate and the count of the exchanged heat amount.
- SC SUN 120 and SC SUN 120 ACS modules, complete with thermal insulation, are pre-wired, tested and ready for use.

### Technical data

Description	Unit	SC SUN 120 SC SUN 120 ACS
Exchanged thermal output	kW	52
Maximum output for primary side	l/h	2400
Maximum output for secondary side	l/min	40

Description	Unit	SC SUN 120 SC SUN 120 ACS
Primary circuit $\Delta T$	$^{\circ}C$	20.0
Collector surface	$m^2$	80
Minimum allowed temperature	$^{\circ}C$	2
Maximum operating temperature	$^{\circ}C$	110
Maximum operating pressure for primary side	bar	10
Primary non-return valve opening pressure	mbar	45
Secondary non-return valve opening pressure	mbar	20
Primary circulation pump absorbed power (max/stand-by)	W	70 / 1.44
Secondary circulation pump absorbed power (max/stand-by)	W	23 / 1
Solar control unit absorbed power (stand-by)	W	0.5
Solar control unit energy efficiency	%	1
Power supply voltage	V	230
Power supply frequency	Hz	50-60
Electrical protection level	IP	40
Net weight	kg	32
Water volume	l	12.6

**Module for solar circuit SC SUN 120 - 120 ACS**

# Structure

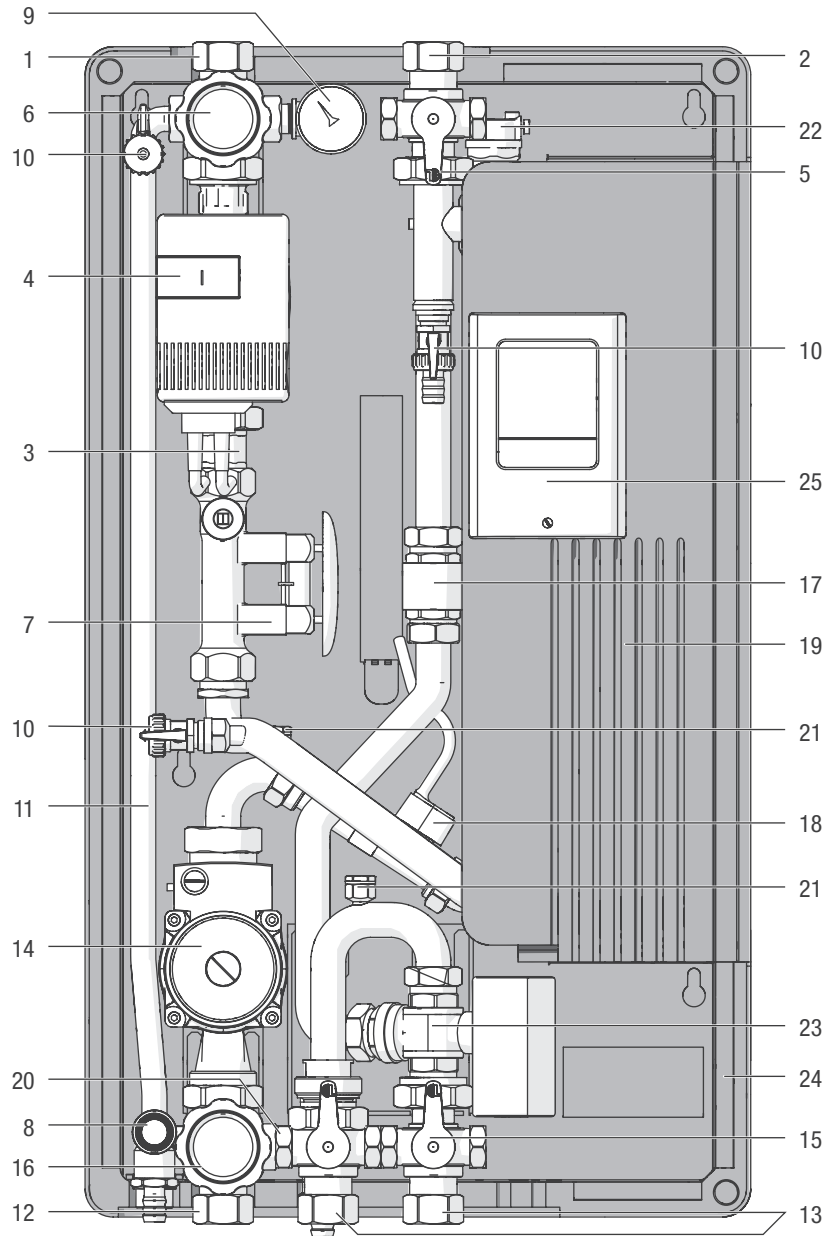

**Primary circuit**

- 1. 3-way ball valve DN 25 1" F
- 2. Ball valve DN 25 1" F
- 3. Check valve
- 4. Solar circulation pump
- 5. Red handle
- 6. Blue handle with thermometer
- 7. Flow regulator
- 8. Solar safety valve
- 9. Pressure gauge
- 10. 1/2" loading/unloading cock
- 11. Piping for connection to expansion vessel

**Secondary circuit**

- 12. 3-way ball valve DN 25 1" F
- 13. Ball valve DN 25 1" F
- 14. System circulation pump
- 15. Red handle
- 16. Blue handle with thermometer
- 17. Check valve
- 18. Flowmeter VFS
- 19. Plate heat exchanger
- 20. Safety valve
- 21. Manual bleeder valve
- 22. Robocal air vent valve
- 23. Motorised diverting valve
- 24. Black EPP insulation 40 g/l
- 25. Electronic regulator

Module for solar circuit SC SUN 120 - 120 ACS

# Dimensions and couplings

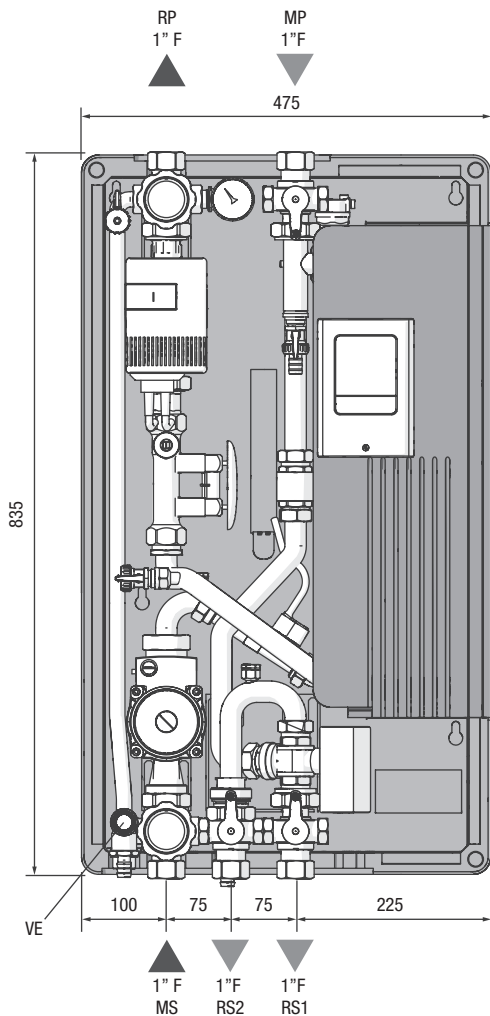

Description	SC SUN 120	SC SUN 120 ACS
MP - Primary delivery line	1" F	
RP - Primary return line	1" F	
MS - Secondary delivery	1" F	
RS1 - Secondary return 1	1" F	
RS2 - Secondary return 2	1" F	
VE - Expansion vessel connection	3/4" M	
Depth	195 mm	

# Hydraulic circuit

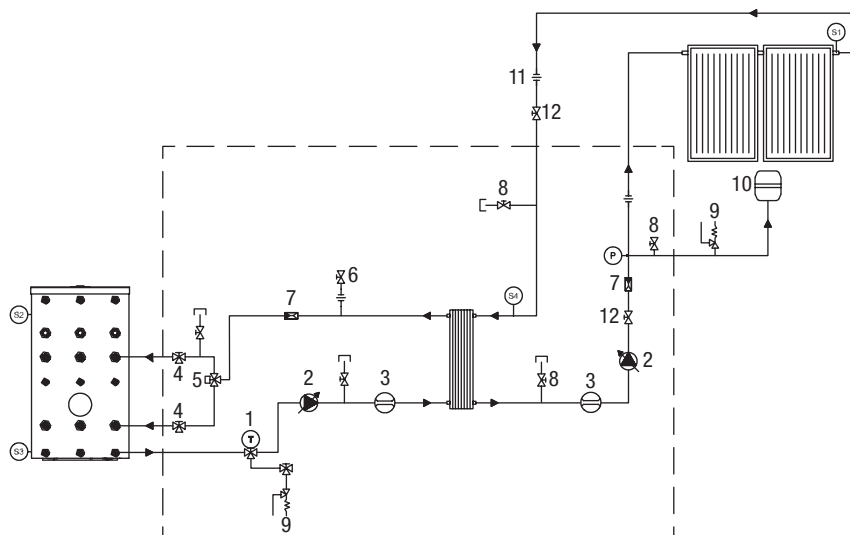

1. Three-way ball valve with thermometer
2. Modulating circulation pump
3. Flow indicator
4. 3-way shut-off valve
5. 3-way diverting valve
6. Manual bleeder valve
7. Non-return valve
8. Manual drain valve with cap
9. Safety valve
10. Expansion vessel
11. Three-piece joint
12. Shut-off valve

Module for solar circuit SC SUN 120 - 120 ACS

# (Solar) Primary circuit pressure drops

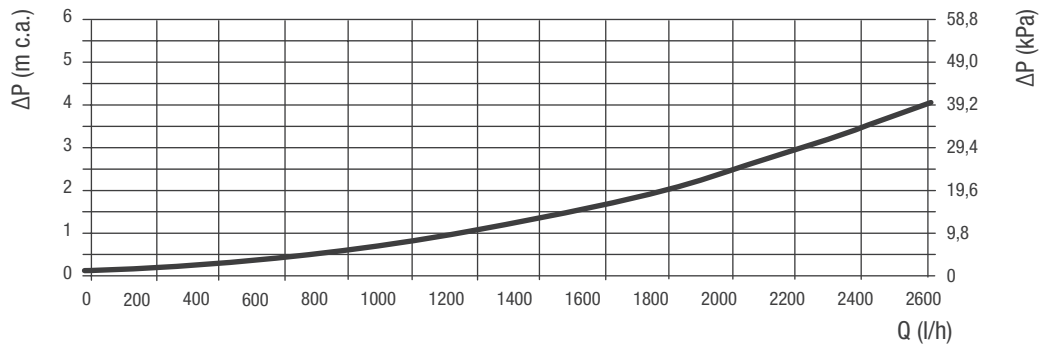

To obtain the useful head, subtract the pressure drop value from the head value read in the solar circulation pump diagram below.

# Circulation pump curves

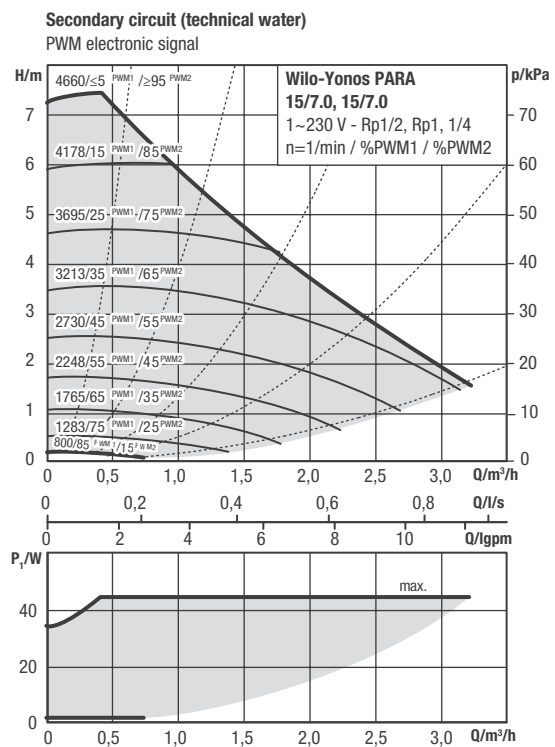
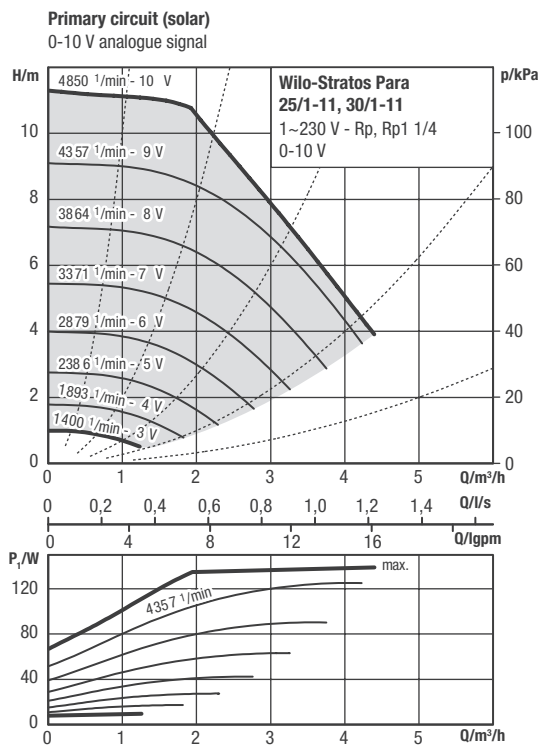

The correct operation of the module is guaranteed if the delivery temperature of the primary circuit is at least 5K higher than the set storage temperature.

## Module for solar circuit SC SUN 120 - 120 ACS

### Wiring diagram

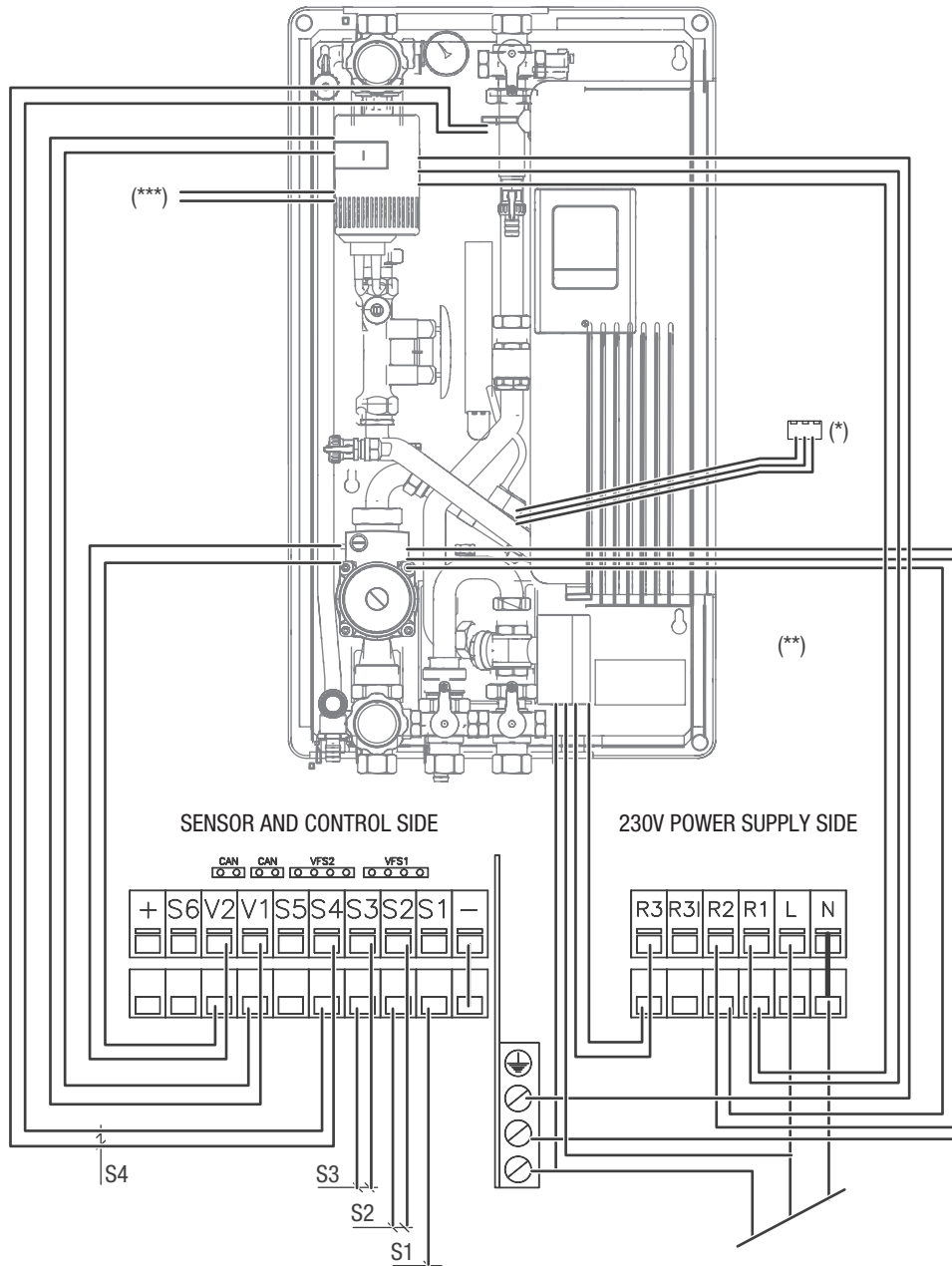

- S1 Solar collector sensor; wire in control unit
- S2 Upper storage sensor/1
- S3 Lower storage sensor/2
- S4 Secondary delivery sensor
- (\*) Insert terminal VFS1 in the control unit
- (\*\*) Trim orange/black cable (NC)
- (\*\*\*) Trim blue/black cable (NC)

The control unit works with PT1000 temperature sensors that guarantee an accurate measurement and therefore an optimal use of the system functions. The temperature sensor cables must be laid separately from the electrical cables and must not, for example, be placed in the same duct.

The cable of the S1 sensor is supplied as standard with a length of 2 metres. S1 and S5 sensor cables can be extended up to 30 m using a cable of at least  $2 \times 1 \text{ mm}^2$ . S2, S3, S4 and S6 sensor cables can be extended up to 10 m using a cable of at least  $2 \times 0.75 \text{ mm}^2$ .

Module for solar circuit SC SUN 120 - 120 ACS

# System diagram

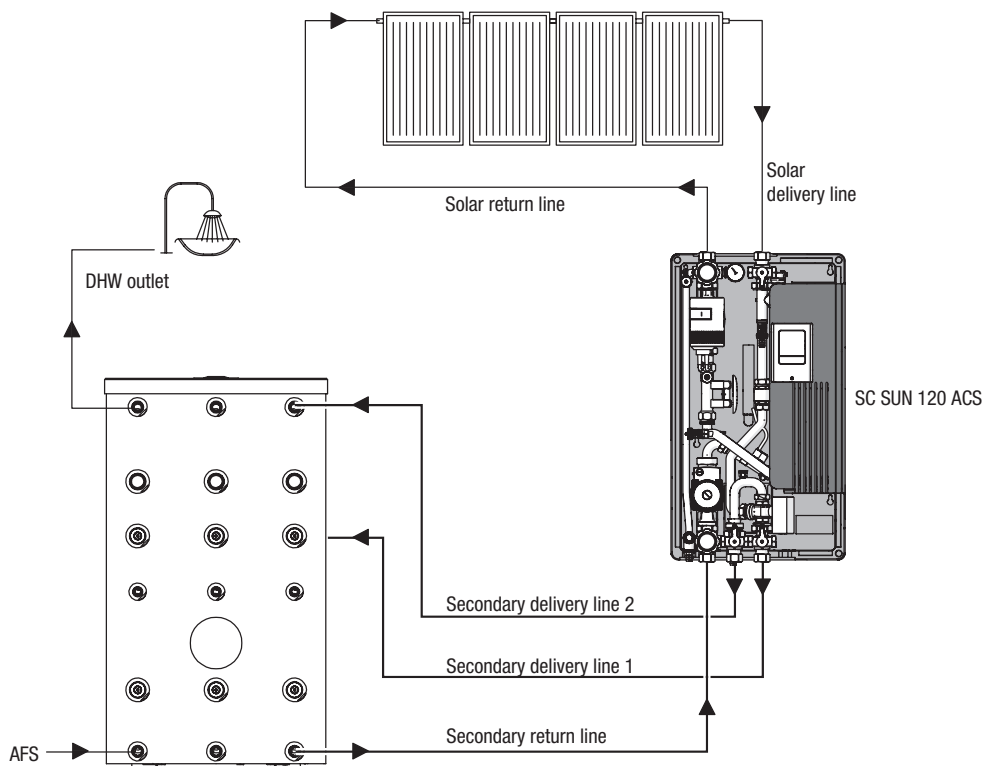
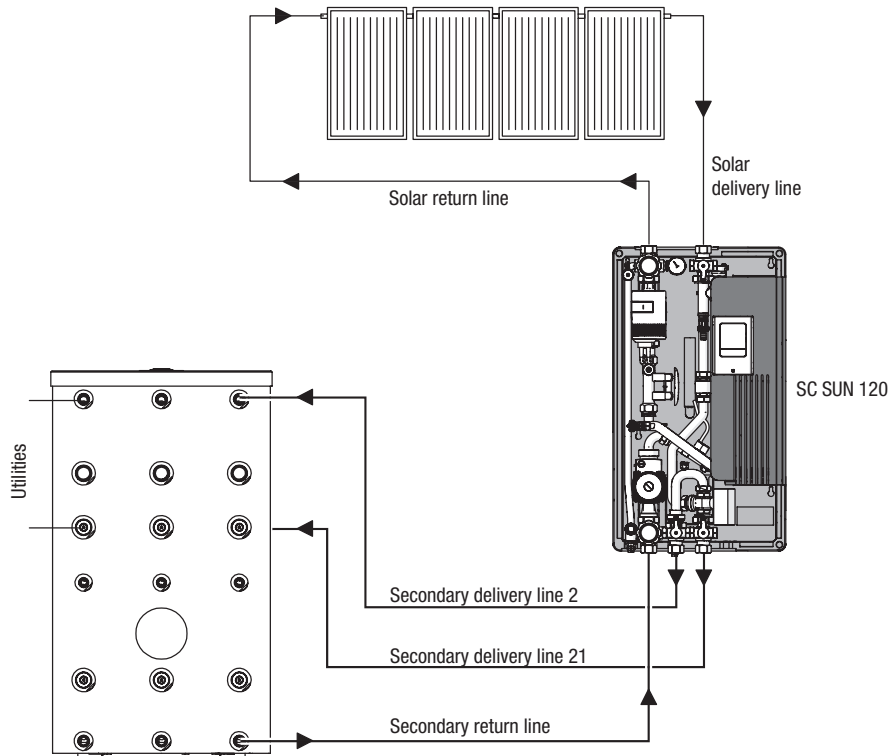

## Module for solar circuit SC SUN 120 - 120 ACS

# Flow rate calibration with flow regulator

## 10÷40 l/min

Calibration:

- Press the bypass handle to display the level in the scale.
- Turn the special regulator until the desired flow rate is reached, the flow rate variation is indicated by the lower part of the floating indicator, adjust while keeping the pressure on the bypass handle.
- Release the bypass handle.

N.B.: When the bypass handle is not pressed, the value on the scale will always be zero.

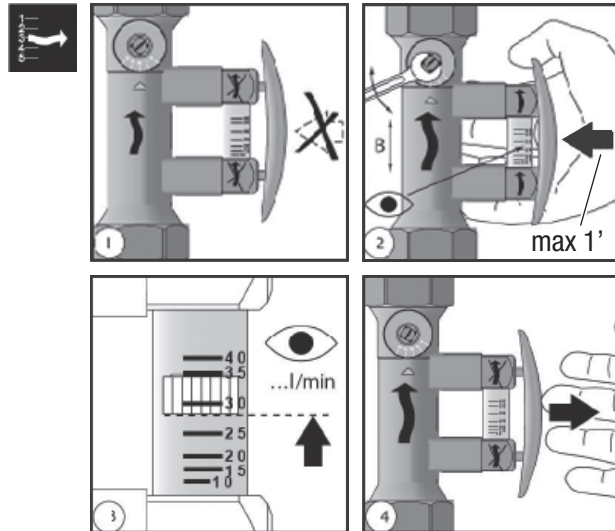

## Control unit

The LTDC4 differential control unit allows efficient use and control of the operation of the solar or heating system. The control unit stands out for its functional and simple use, almost "self-explanatory". For each programming point, the data is associated with certain functions with additional explanations. The menu of the control unit contains keywords for settings and measured values, but also help texts and graphs. The LTDC4 can be used as a differential temperature control unit for various system variants. At the time of delivery of the product, all the above parameters have default values set at the factory; these parameters can be reset by a qualified technician, depending on the request of the user. The menu of the control unit contains keywords for settings and measured values, but also help texts and graphs.

Main features of the LTDC4:

- Displaying of graphs and texts on the display.
- Simple control of measured current values.
- Analysis and monitoring of the system through statistical graphs, etc.
- Extensive setting menus with explanations.
- PWM and 0-10V output.
- The menu lock can be activated to prevent unwanted changes.
- Function to restore previous values or factory settings.
- Wide range of additional functions.

## Disposal

The control unit complies with the European RoHS Directive 2002/95/EC which concerns restrictions on the use of certain substances in electrical and electronic equipment.



## Module for solar circuit SC SUN 120 - 120 ACS

### Technical Specifications

<b>Electrical Specifications</b>	
Voltage	230 VAC $\pm$ 10%
Frequency	50 $\div$ 60 Hz
Current consumption	2 VA
Contact power	
electronic relay R1	min. 5 W / max.120 W for AC3
electronic relay R2	min. 5 W / max. 120 W for AC3
mechanical relay R3	460 VA for AC1 / 185 W for AC3
PMV outlet	for working resistance 10 k $\Omega$
Internal fuse	2 A slow-blow 250 V
Protection level	IP40
Protection class	II
Inlet sensors	6 $\times$ PT1000 + 2 $\times$ Vortex flow sensor (VFS)
Measurement range	PT1000 -40 $^{\circ}$ C up to 300 $^{\circ}$ C
Vortex sensor	0 $^{\circ}$ C to 100 $^{\circ}$ C (-25 $^{\circ}$ C /120 $^{\circ}$ C short time) 1 - 12 l/min (VFS1-12) / 2 - 40 l/min (VFS2-40) / 5 - 100 l/min (VFS5-100) / 10 - 200 l/min (VFS10-200)
<b>Allowed climatic conditions</b>	
Ambient temperature:	
for control unit operation	0 $^{\circ}$ C $\div$ 40 $^{\circ}$ C
for transport/storage	0 $^{\circ}$ C $\div$ 60 $^{\circ}$ C
Air humidity:	
for control unit operation	max. 85% relative humidity with 25 $^{\circ}$ C
for transport/storage	no moisture condensation allowed
<b>Other specifications and dimensions</b>	
Enclosure	3 Parts, ABS Plastic
External dimensions	163 mm $\times$ 110 mm $\times$ 52 mm
Opening dimensions for installation	157 mm $\times$ 106 mm $\times$ 31 mm
Display	large graphic display, 128 $\times$ 128 points
LED	multicolour green/red
Programming	4 buttons
<b>Temperature sensors</b>	
Collector or boiler sensor	PT1000, e.g. TT/S2 up to 180 $^{\circ}$ C
Storage sensor	PT1000, e.g. TR/P4 up to 95 $^{\circ}$ C
Contact sensor	PT1000, e.g. contact sensor TR/P4 up to 95 $^{\circ}$ C
Sensor distance	PT1000: 2 $\times$ 1 mm <sup>2</sup> up to 30 m max.

### Temperature resistance table for PT1000 sensors

<b>Resistance [<math>\Omega</math>]</b>	1000	1039	1077	1116	1155	1194	1232	1270	1308	1347	1385
<b>Temperature [<math>^{\circ}</math>C]</b>	0	10	20	30	40	50	60	70	80	90	100

**Module for solar circuit SC SUN 120 - 120 ACS**

**Hydraulic variants**

The diagrams that can be set for the STS 120 module are number 26 and number 27, shown in the images below.

Layout 26

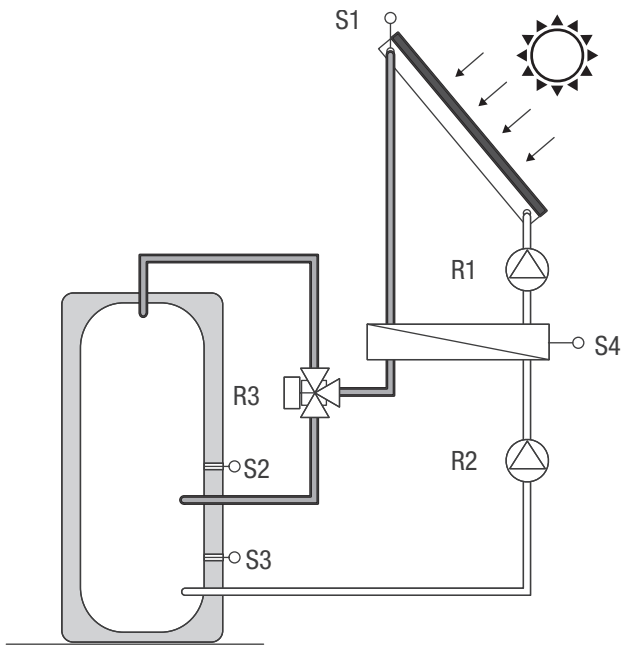

- S1 Manifold
- S2 Upper storage
- S3 Lower storage
- S4 Exchanger
- R1 Solar pump
- R2 Secondary pump
- R3 Diverting valve

Layout 27

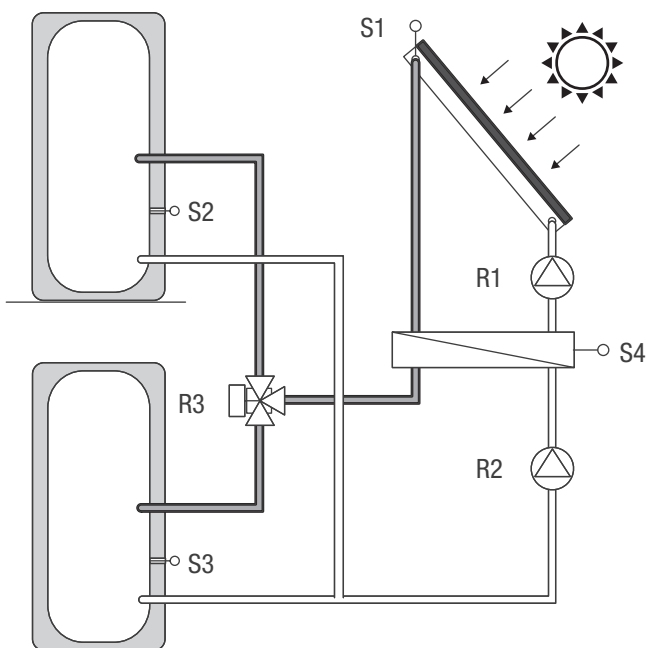

- S1 Manifold
- S2 Storage 1
- S3 Storage 2
- S4 Exchanger
- R1 Solar pump
- R2 Secondary pump
- R3 Diverting valve

## Module for solar circuit SC SUN 120 - 120 ACS

# Key functions

## Settings

### Tmin sensor (S1) = Enable/start temperature on sensor S1:

If this value is exceeded on sensor S1 and the other conditions also occur, the control unit drives the associated pump and/or valve. If the temperature at the sensor drops 5°C below this value, the control unit stops the pump and/or valve again.

### Storage 1 priority

Determines the order in which the storage tanks are filled. If the same priority is set for the two storage tanks, the load is not switched off until the active storage tank can no longer be charged.

### $\Delta T$ on storage 1 = Temperature differential for storage 1 loading:

If the temperature difference between the reference sensors is exceeded and the other conditions are also met, the control unit switches on the connected relay. If the temperature drops below  $\Delta T$  Off, the relay switches off.

If the set temperature differential is too low, the control unit may not function effectively, depending on the system and the position of the sensors. Special on/off functions can be added to control speed.

### Tmax sensor (S2) = Switch-off temperature on sensor S2

If this value is exceeded on sensor S2, the control unit stops the associated pump and/or valve. If the temperature drops below this value again and the other conditions also occur, the control unit will operate the associated pump and/or valve again.

### Storage 1 priority

Determines the order in which the storage tanks are filled. If the same priority is set for the two storage tanks, the load is not switched off until the active storage tank can no longer be charged.

### $\Delta T$ on storage 2 = Temperature differential for storage 2 loading

If the temperature difference between the reference sensors is exceeded and the other conditions are also met, the control unit switches on the connected relay. If the temperature drops below  $\Delta T$  Off, the relay switches off.

If the set temperature differential is too low, the control unit may not function effectively, depending on the system and the position of the sensors.

### Tmax sensor S3 = Switch-off temperature on sensor S3

If this value is exceeded on sensor S3, the control unit stops the associated pump and/or valve. If the temperature drops below this value again and the other conditions also occur, the control unit will operate the associated pump and/or valve again.

### T-priority = Temperature level for absolute priority

In systems with several storage tanks, the lowest priority storage tank is only loaded after the temperature limit set on the highest priority storage sensor has been exceeded.

### Load time = Load interruption in the storage tank having lower priority

The lowest priority storage tank loading is interrupted after a certain time (which can be set) to check if the collector has reached the temperature level required to start loading the lowest priority storage tank. If this is the case, the priority storage tank is loaded. If this is not the case, the increment is measured (see section "4.16. - Increase") to check if it is possible to load the priority storage tank in a short time.

### Increase = Extension of loading pause due to temperature increase in the collector

In order to allow a precise setting of the load priorities of systems with more than one storage tank, in this menu the temperature increase of the collector must be set so that the load interruption of the storage tank with the lowest priority is prolonged by one minute. The interruption is prolonged because it is expected that the increase in the temperature of the collector can quickly load the storage tank having lower priority.

As soon as the  $\Delta t$  conditions are reached, the priority storage tank is loaded. If the temperature increase is lower than the set value, the lowest priority storage tank loading will be activated again.

## Protection functions

### System protection

The protection system prevents overheating of the system components by automatically switching off the solar pump. If the value "Sys. prot. on" is exceeded on the collector for 1 minute, the pump will switch off and remain switched off. The pump is reactivated when the temperature drops below "Sys. prot. off".

### Collector protection

Collector protection prevents overheating of the collector. The pump is switched on to transfer heat from the collector to the storage tank. If the value "Coll. prot. on" is exceeded on the collector sensor, the pump is activated when the temperature "Coll. prot. off" or "PC Tmax Storage" in the storage tank or pool is exceeded.

If the collector protection is active and both storage tank and pool are present, the storage tank is heated up to the level "PC storage tank S(x) Max" above Tmax S2. If only one pool is used, the pool is not used for collector protection.

The protection of the system has higher priority than the protection of the collector. Even when the conditions to activate the collector protection are present, the solar pump is switched off when reaching the temp. "Prot.Coll.On."

### Cooling

In the hydraulic variants with solar system when the cooling function is activated, the excess energy of the storage tank is returned to the collector. This only happens if the temperature in the storage tank is higher than the "Cooling Tset" value and the collector is at least 20°C colder than the storage tank and therefore the storage temperature has dropped below the "Cooling Tset" value. In systems with two storage tanks, the setting applies to both storage tanks.

When the cooling function is active, there is energy loss through the collector! Cooling should only be active in periods with low heating demand, e.g. during long absence/holidays.

## Module for solar circuit SC SUN 120 - 120 ACS

### Antifreeze

You can activate a frost protection/antifreeze function on two levels. In level 1 the control unit activates the pump for one minute every hour if the temperature of the collector drops below the set value of "Antifreeze level 1". If the collector temperature falls below the set value of "Antifreeze level 2", the control unit continuously activates the pump. If the collector temperature exceeds the "Antifreeze level 2" value by 2°C, the pump switches off again.

This function leads to a loss of energy through the collector! Normally not activated for solar systems with antifreeze. Observe the operating instructions for the other system components!

### Anti-jam protection

If the anti-jam function is active, the control unit will activate the relay and connected components every day at 12:00 noon ("daily" setting) or weekly every Sunday at 12:00 noon ("weekly" setting) for 5 seconds to prevent the pump and/or valve from blocking after a long period of inactivity.

## Accessories

### Connect Solar MR - Hydraulic delivery and return kit

The 7.5 m hydraulic delivery and return kit with adjustable flow allows you to hydraulically connect an IDRA DS solar cylinder to a Beretta forced circulation solar collector system. Using the hydraulic unit it is possible to carry out the following operations: washing, loading and unloading of the system, replacement of the circulation

pump without having to empty the system. The compact safety unit includes a safety valve, a pressure gauge and a hose fitting for connection to the expansion vessel. There are two check valves in the delivery and return pipes.

#### Main components

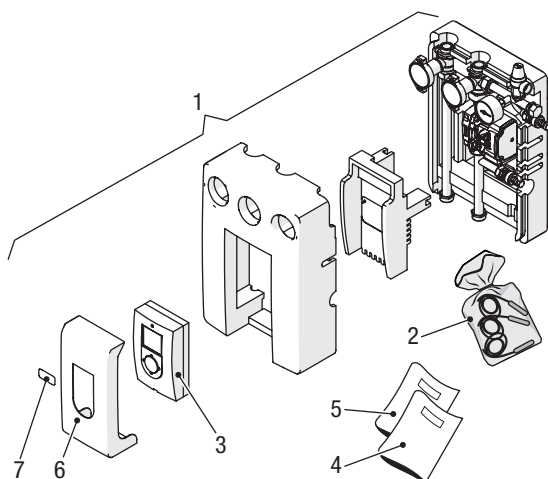

1. Solar Station
  2. Bag containing 3 sensors with a length of 1.5 m
  3. Solar regulator
- The following material is supplied in a plastic bag:
4. Instruction manual
  5. Instruction manual for solar regulator
  6. Solar regulator casing
  7. Logo

#### Technical data sheet

Description	Unit	Connect Solar MR
Maximum operating pressure	bar	6
Maximum operating temperature	°C	110
Dimensions LxHxD	mm	313x418x185
Net weight with insulation	kg	5
Electrical power supply	V~Hz	230~50
Absorbed electrical current min/ max	A	0.04 ÷ 0.58
Power input min/max	W	5 ÷ 63

#### Useful head available

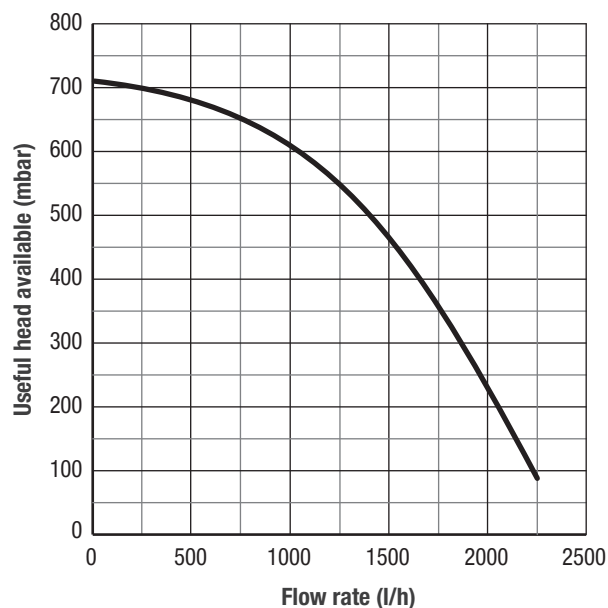

Values referred to a mix of water and 30% glycol.

Accessories

Hydraulic connections

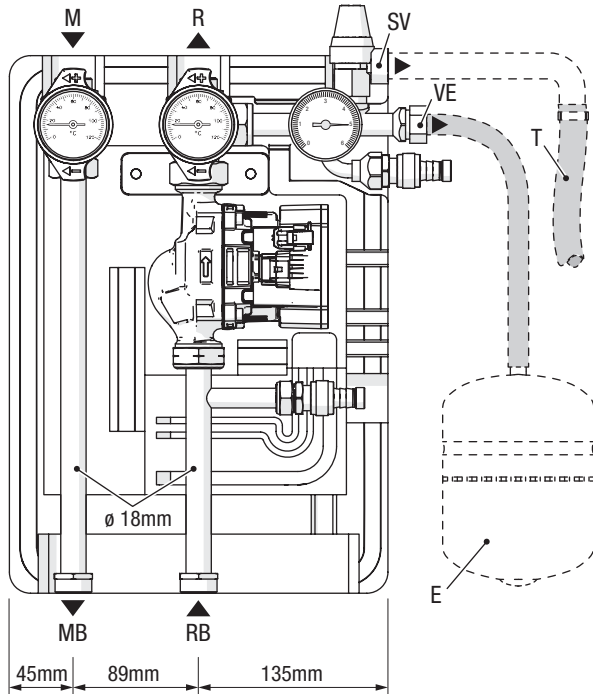

- M Solar delivery line (3/4" M). Inlet of heat transfer fluid from solar collector.
- R Solar return line (3/4" M). Outlet of heat transfer fluid towards solar collector.
- MB Storage system delivery line (3/4" M). Outlet of heat transfer fluid towards solar storage system.
- RB Storage system return line (3/4" M). Inlet of heat transfer fluid from solar storage system.
- SV Safety valve drain.
- VE Expansion vessel connection.
- E Solar expansion vessel (not supplied).
- T Drain pipe for safety valve (not supplied).

Electrical connections

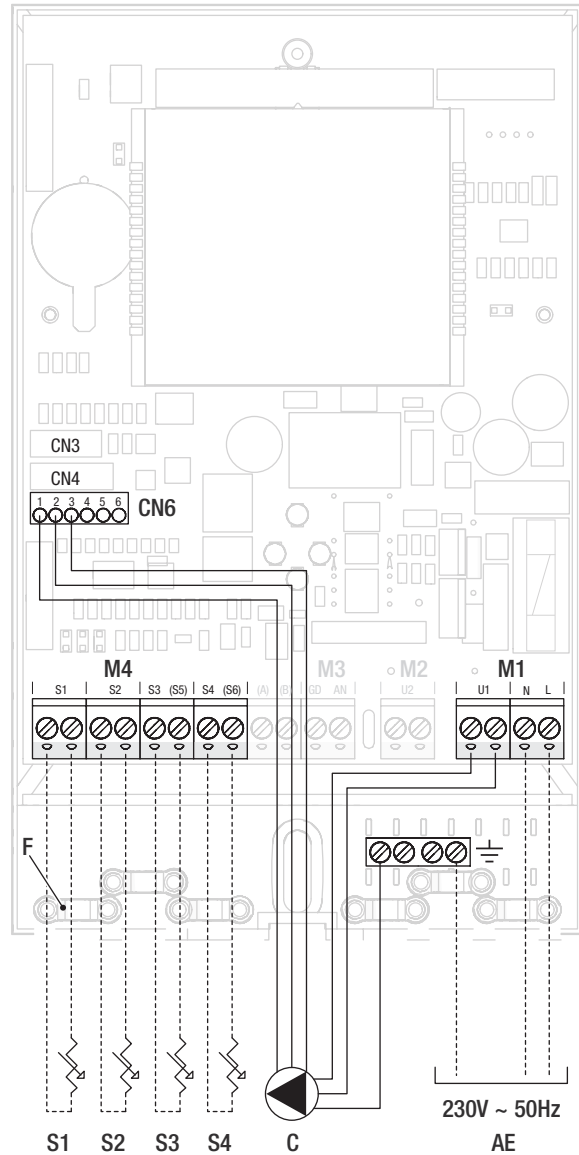

- AE Electrical power supply (connections to be made by the installer).
- S1 Collector temperature sensor 1 (connections to be made by the installer).
- S2 Lower temperature sensor for storage system (connections to be made by the installer).
- S3 Upper temperature sensor for storage system (connections to be made by the installer).
- S4 Sensor option (not supplied).
- M1-M4 Terminal board.
- C Circulation pump.
- CN6 PWM connector.
- F Cable grommet.

Accessories

Hydraulic delivery and return kit layout

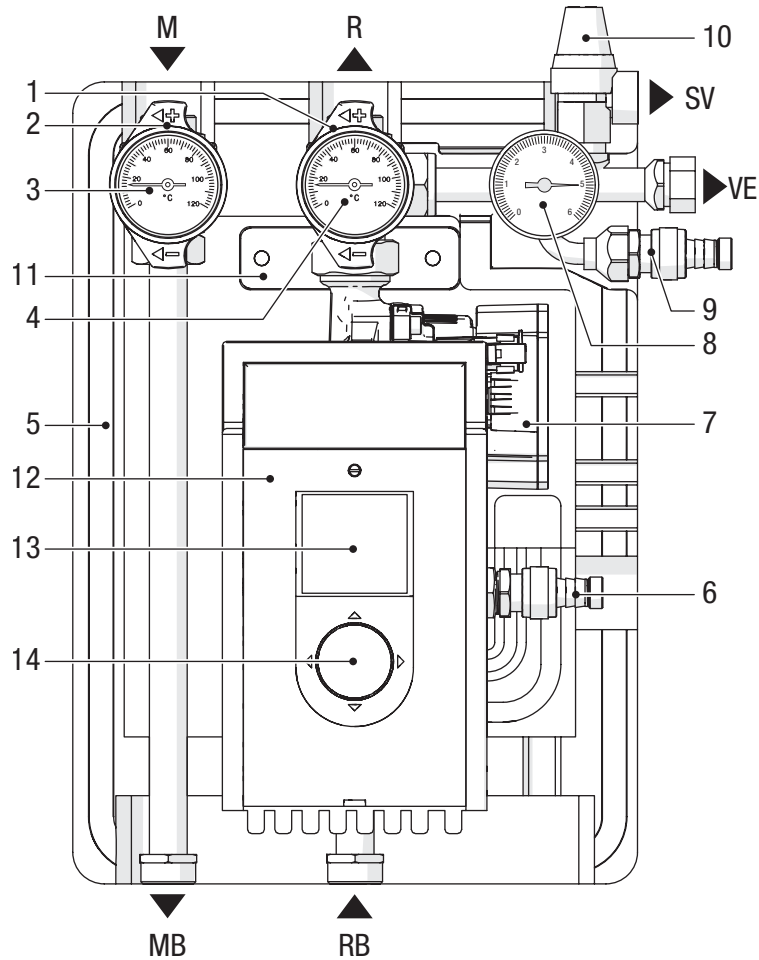

- 1 Return valve (solar system return) with integrated non-return valve
- 2 Delivery valve (solar system flow) with integrated non-return valve
- 3 Delivery thermometer
- 4 Return thermometer
- 5 Insulation
- 6 System load/unload valve A
- 7 Circulation pump
- 8 Pressure gauge
- 9 System load/unload valve B
- 10 Safety valve (6 bar)
- 11 Mounting bracket
- 12 Solar regulator
- 13 Display
- 14 Multidirectional joystick

- M Solar delivery line. Inlet of heat transfer fluid from solar collector.
- R Solar return. Outlet of heat transfer fluid towards solar collector.
- MB Storage system delivery line. Outlet of heat transfer fluid towards solar storage system.
- RB Storage system return line. Inlet of heat transfer fluid from solar storage system.
- SV Safety valve drain
- VE Expansion vessel connection

**Accessories**

# TOP MODULATING hydraulic delivery and return kit

The TOP MODULATING Solar Station allows transferring sun power from collectors to a storage system. The solar station is enclosed in a PPE (Polypropylene foam) insulating casing and is designed to perform:

- system flushing.
- system loading and emptying.
- circulation pump disassembly.

The main components are:

- High-efficiency variable-speed circulation pump.
- Shut-off valves with non-return function.
- Thermometers.
- Pressure gauge.
- Fitting for connection to a solar expansion vessel.
- Safety valve with activation pressure at 10 bar.

## Main components

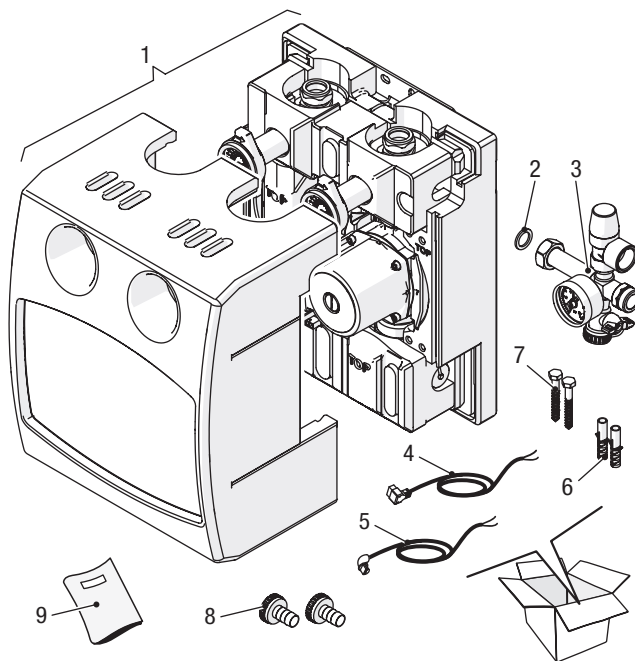

1. Solar Station
2. Seal
3. Safety unit
4. Pump power supply cable
5. PWM pump management and speed control cable
6. Dowels (8mm)
7. Fixing screws (8mm)
8. Hose barb with swivel (3/4" x 14)
9. Instruction manual

## Minimum recommended clearance zones

The recommended clearance zones for assembly and maintenance are 300 mm per side (including also the expansion vessel). Place the solar station at a height that allows reading the thermometers easily.

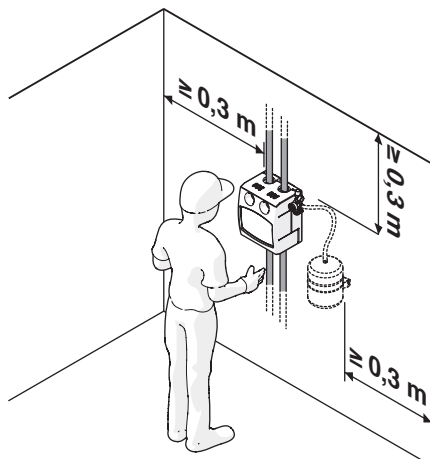

## Operation

### Water+glycol pre-mixing

Before filling the system, the separately supplied glycol must be premixed with water in a container. For example, 40% glycol and 60% water ensure frost resistance down to -21 °C. Propylene glycol, supplied as an accessory kit, is specifically designed for solar applications as it retains its characteristics in the range of -32 ÷ 180 °C. It is also non-toxic, biodegradable and biocompatible. Do not fill pure glycol into the system and then add water.

Do not use manual or automatic filling systems. If the chlorine content is very high, distilled water must be used for the mixture.

Antifreeze	Temperature	Density
50%	-32 °C	1.045 kg/dm <sup>3</sup>
40%	-21 °C	1.037 kg/dm <sup>3</sup>
30%	-13 °C	1.029 kg/dm <sup>3</sup>

## Accessories

### Setting the flow rate

Setting the correct flow rate of the system is essential for the proper operation of the whole system.

Set the flow regulator (V) to the fully open position.

The pump is modulating and is managed by the solar regulator through PWM signal. For the setting of the flow rate range, refer to the instructions supplied with the solar regulator.

In any case, check the nominal flow rate according to the number of solar collectors combined with the solar cylinder.

To do this:

- Use the manual mode of the solar regulator to set the maximum speed level of the circulating pump (see solar regulator instructions).
- Check the value read by the meter (G) and adjust the flow by working the flow regulator (V) in order to obtain the flow value required by the system.
- Set the automatic mode of the solar regulator.

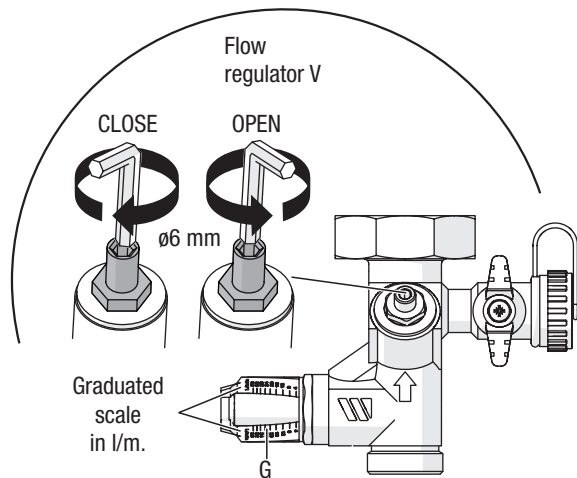
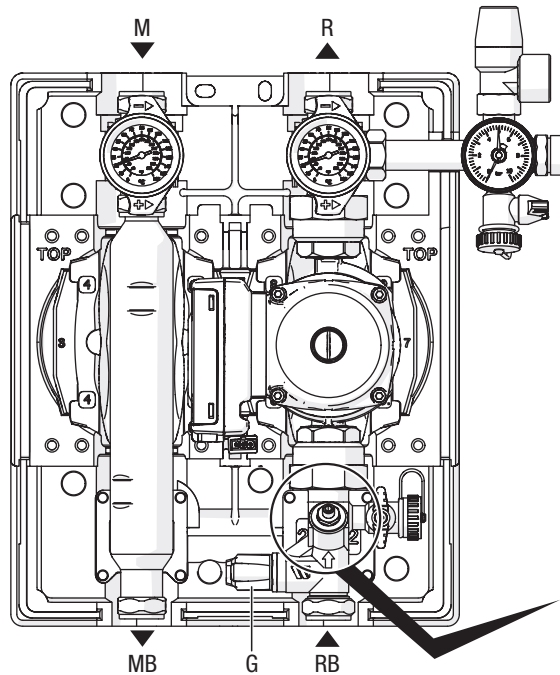

### Structure

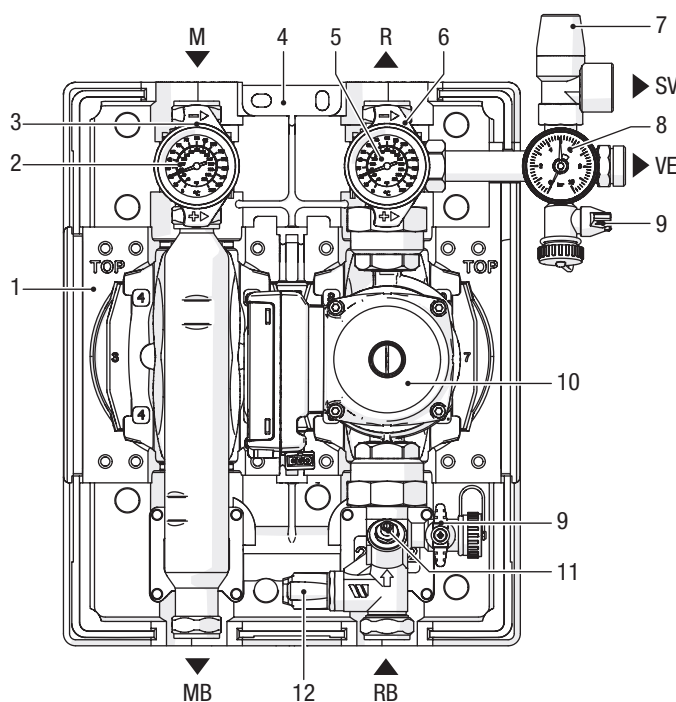

1. Insulation
  2. Delivery thermometer
  3. Solar system delivery valve with integrated non-return valve
  4. Mounting bracket
  5. Return thermometer
  6. Solar system return valve with integrated non-return valve
  7. 10-bar safety valve
  8. Pressure gauge
  9. System load/unload valve
  10. Circulation pump
  11. Flow regulator / Shut-off valve
  12. Flowmeter (4-36 l/min)
- M Solar delivery line Inlet of heat transfer fluid from solar collector.  
 R Solar return. Outlet of heat transfer fluid towards solar collector.  
 MB Storage system delivery line. Outlet of heat transfer fluid towards solar storage system  
 RB Storage system return line. Inlet of heat transfer fluid from solar storage system  
 SV Safety valve drain  
 VE Expansion vessel connection

Accessories

Hydraulic connections

- M Solar delivery line (Ø22mm). Inlet of heat transfer fluid from solar collector.
- R Solar return line (Ø22mm). Outlet of heat transfer fluid towards solar collector.
- MB Storage system delivery line (Ø22mm). Outlet of heat transfer fluid towards solar storage system.
- RB Storage system return line (Ø22mm). Inlet of heat transfer fluid from solar storage system.
- SV Safety valve drain (3/4" F)
- VE Expansion vessel connection (3/4" M)
- E Solar expansion vessel (not supplied)
- T Drain pipe for safety valve (not supplied)

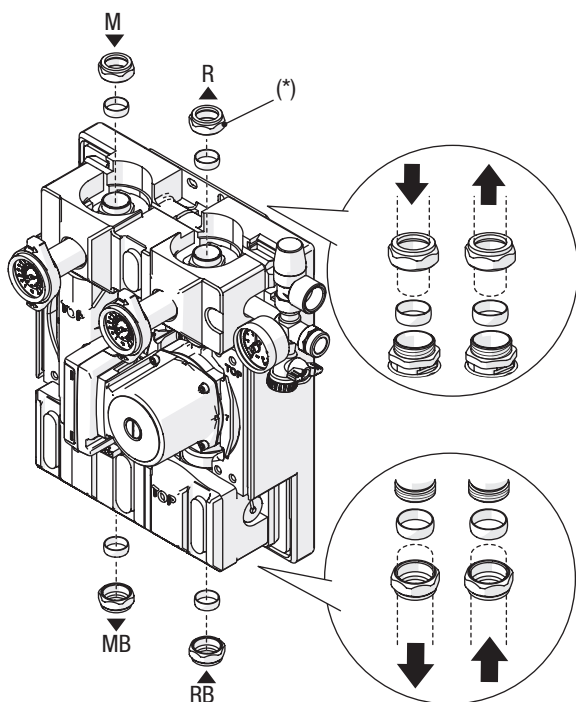
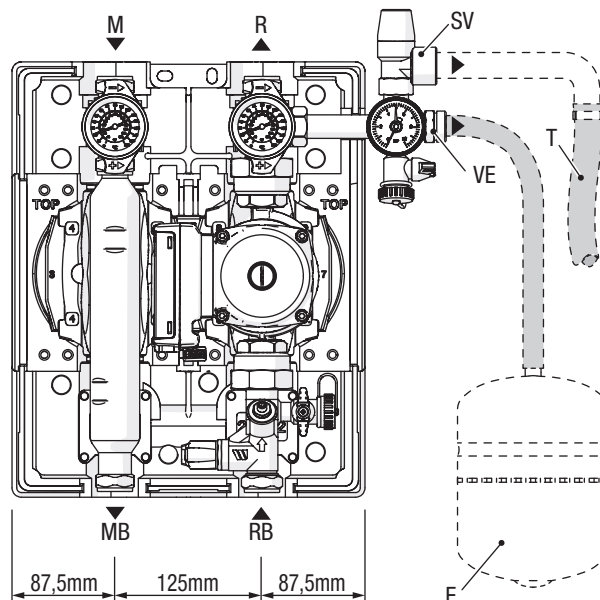

- Connect the outlet of the safety valve to a pipe (T) to recover any spillage of the solar fluid and to avoid scalding.
- Connect the expansion vessel (E) suitable for applications in solar systems to the 3/4" connection (VE).
- Connect the delivery (M) and return (R) connections on the top of the solar station to the solar system.
- Connect the delivery (MB) and return (RB) connections on the bottom of the solar station to the storage system.

(\*) Accessory available to change from tighten-in fitting to 1" M threaded fitting.

Size the solar expansion vessel so as to ensure the total absorption of the expansion of the fluid contained in the system, referring to the relevant regulations in force. In particular, consider the characteristics of the fluid, the high variations in operating temperature and the formation of steam in the stagnation phase of the solar collector. The correct sizing of the expansion vessel allows the absorption of volume variations of the heat transfer fluid, avoiding excessive increases in pressure. A limited pressure variation prevents the safety valve opening pressure from being reached and the consequent discharge of fluid.

Accessories

Technical data

DESCRIPTION		
Maximum operating pressure	bar	10
Maximum operating temperature	°C	95
Dimensions LxHxD	mm	369 x 414.5 x 240.5
Net weight with insulation	kg	8
Electrical power supply	V~Hz	230~50
Absorbed electrical current min/ max	A	0.06 ÷ 0.68
Power input min/max	W	7 ÷ 69

Useful head available

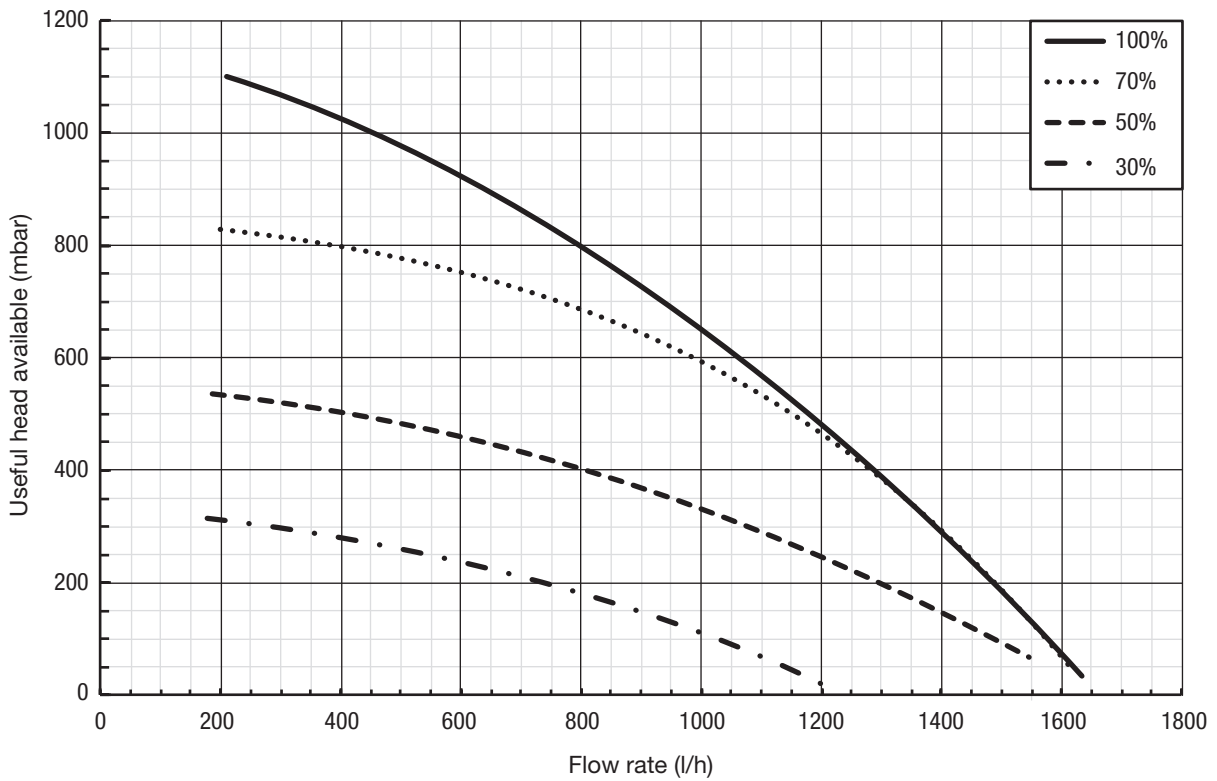

Values referred to a mix of water and 30% glycol.

The circulation pump speed is controlled through PWM signal and varies according to the thermal gradient between solar collectors and storage. Pay attention to the system overall load losses (exchanger, solar collectors and pipes) at the maximum foreseen flow rate conditions.

## Accessories

# Connect Solar R - Hydraulic return kit

The hydraulic return kit allows you to hydraulically connect an IDRA DS solar cylinder to a Beretta forced circulation solar collector system. This unit is equipped with a variable flow circulation pump.

## Main components

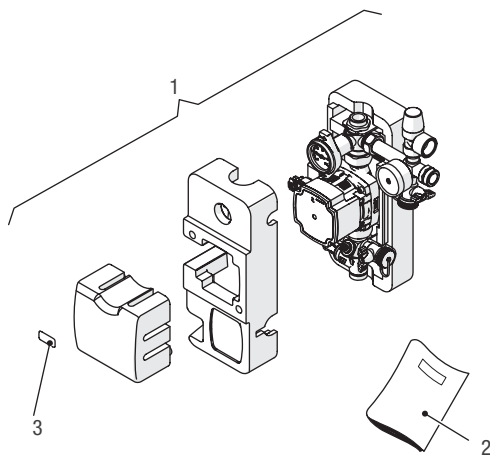

### 1. Solar Station

The following material is supplied in a plastic bag:

2. Instruction manual
3. Logo

## Technical data sheet

Description	Unit	Connect Solar R
Maximum operating pressure	bar	6
Maximum operating temperature	°C	110
Dimensions LxHxD	mm	264x362x215
Net weight with insulation	kg	3.8
Electrical power supply	V~Hz	230~50
Absorbed electrical current min/ max	A	0.04 ÷ 0.48
Power input min/max	W	2 ÷ 45

## Useful head available

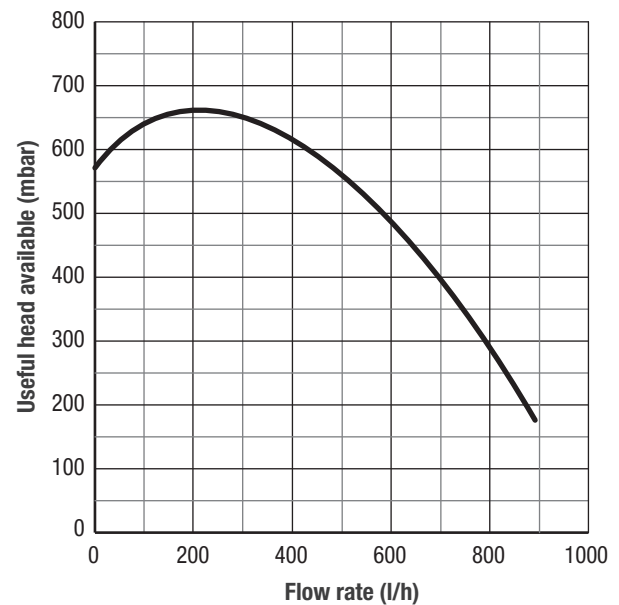

Values referred to a mix of water and 30% glycol.

## Accessories

### Hydraulic connections

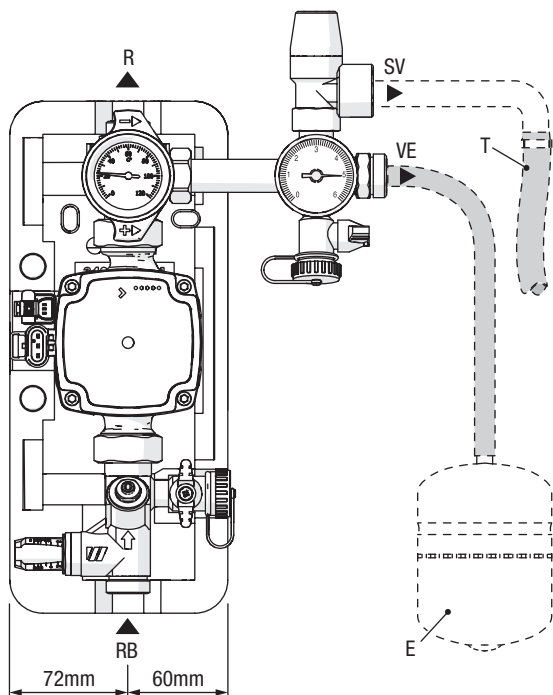

- R Solar return line (3/4" M). Outlet of heat transfer fluid towards solar collector.
- RB Storage system return line (3/4" M). Inlet of heat transfer fluid from solar storage system.
- SV Safety valve drain
- VE Expansion vessel connection
- E Solar expansion vessel (not supplied)
- T Drain pipe for safety valve (not supplied)

### Electrical connections

For electrical connections:

- Remove the front insulation (1).
- Cables must be inserted through the cable ducts (F).

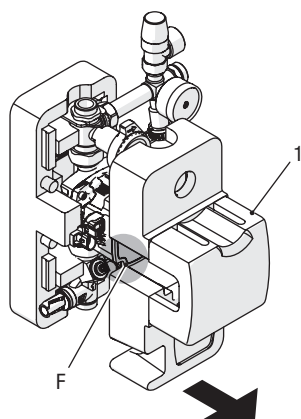

- Connect the connectors as shown in the figure:

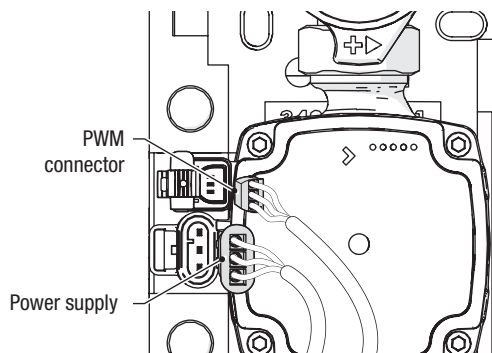

If you want to control the circulation pump in ON/OFF mode, the PWM cable is not required.

If you want to control the circulation pump in modulating mode by means of a solar regulator, check the compatibility of the chosen regulator with the characteristics of the PWM signal (see paragraph "CONTROL SIGNALS" below).

### Control signals

The circulation pump must be controlled via a PWM (pulse width modulation) low-voltage digital signal. The speed changes according to the input signal as indicated in the paragraph "PWM input signal". Here below are the main characteristics required of the PWM signal output by the associated regulator.

**ATTENTION** - Check the characteristics of your regulator PWM signal to ensure they comply with the features below. Different signals could irreversibly damage the circulation pump on-board electronics.

#### PWM low-voltage digital signal

The PWM square wave signal was designed for a frequency interval between 100 and 4000 Hz. The PWM signal is used to set circulation pump speed.

#### Example of Duty cycle

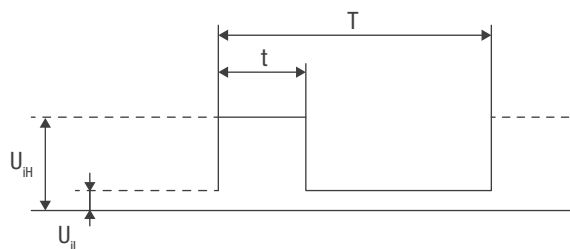

- T Period
- d Duty cycle (t/T)
- $U_{iH}$  High voltage level of the input signal
- $U_{iL}$  Low voltage level of the input signal
- $I_{iH}$  Current intensity of the input signal

Example	Evaluation
T = 2 ms (500 Hz)	$U_{iH} = 4-24 V$
t = 0.6 ms	$U_{iL} \leq 1 V$
d % = $100 \times 0.6 / 2 = 30 \%$	$I_{iH} \leq 10 mA$ (dependent on $U_{iH}$ )

## Accessories

### PWM input signal

With a low input value (<5 % PWM), the pump cannot start. The pump stops when input signal is 5 to 8% of PWM signal or when PWM signal is not present, for safety reasons. If the pump receives no input, due for instance to failure of the signal cable, it will stop in order to avoid solar system overheating.

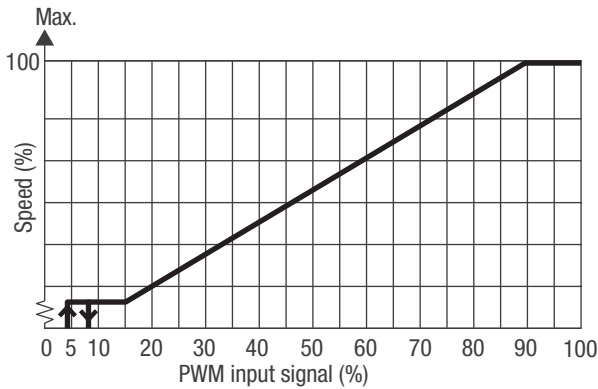

### Electronic circuit

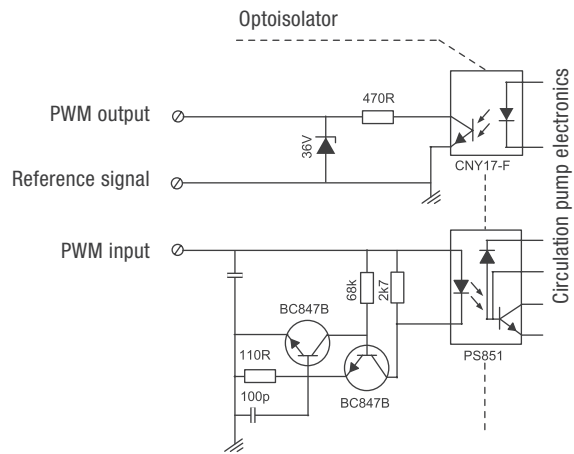

### Technical data

Maximum power	Symbol	Value
PWM input frequency	f	100-4000 Hz
Stand-by consumption		< 1 W
High voltage level of the input signal	$U_{IH}$	4-24 V
Low voltage level of the input signal	$U_{IL}$	< 1 V
Current intensity of the input signal	$I_{IH}$	< 10 mA
Input duty cycle	PWM	0-100%

## Hydraulic return kit layout

1. Return valve (solar system return line) with integrated non-return valve
  2. Return thermometer
  3. Insulation
  4. Flow regulator
  5. Flowmeter
  6. System load/unload valve A
  7. Circulation pump
  8. Mounting bracket
  9. System load/unload valve B
  10. Pressure gauge
  11. Safety valve (6 bar)
- R Solar return. Outlet of heat transfer fluid towards solar collector.  
 RB Storage system return line. Inlet of heat transfer fluid from solar storage system.  
 SV Safety valve drain  
 VE Expansion vessel connection

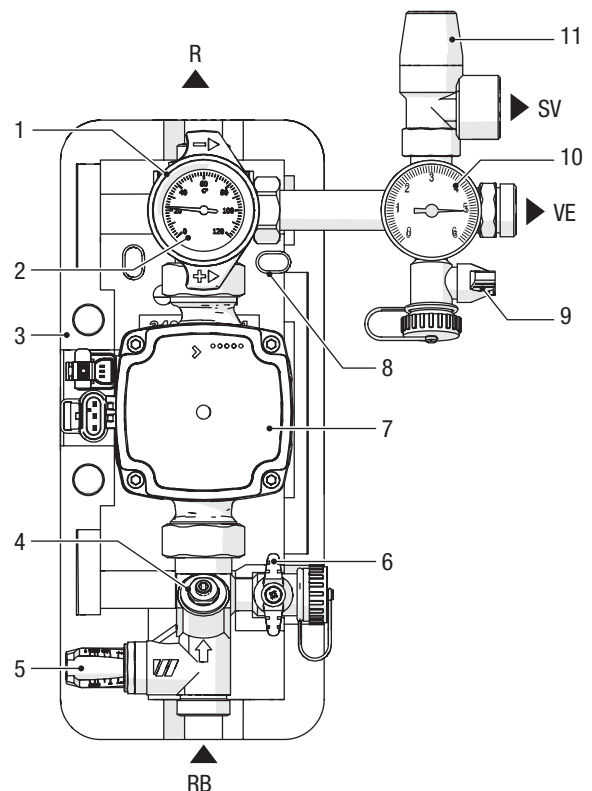

### Accessories

## Manual degasser kit

The manual degasser facilitates the venting operations and must be mounted in combination with the welded fittings on the delivery pipe of the solar circuit, at the highest point of the system.

Once the system has been vented, the manual degasser must be closed.

If an automatic loading pump is used, the manual degasser is not necessary.

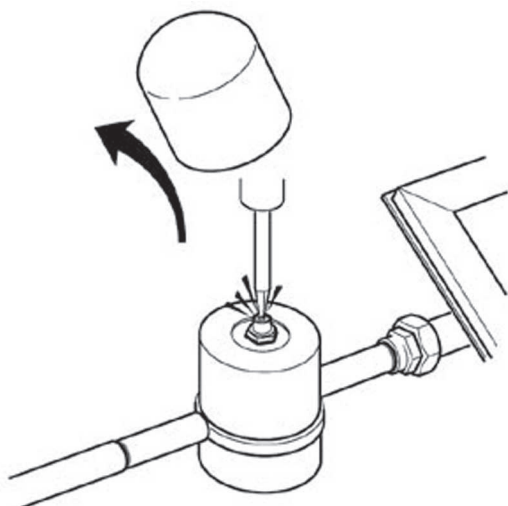

## Expansion vessel kit

The 18 and 24 litre expansion vessels can be installed with the wall mounting bracket kit. Models from 35 to 300 litres have feet and can be placed on the ground.

The precharging pressure of the expansion vessels is 2.5 bar. The hose (L) is included in the supply.

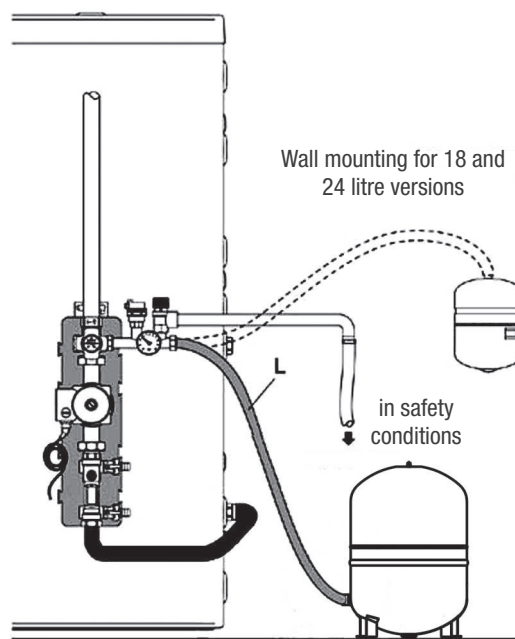

Floor-standing support for 35, 50, 100 and 300 litre versions

## Thermostatic mixer kit 3/4"

To maintain the domestic hot water temperature below 60 °C, a thermostatic mixer must be installed at the outlet of the cylinder.

Mount the valve correctly:

- "RED dot" hot water inlet from the solar cylinder;
- "BLUE dot" domestic cold water inlet.

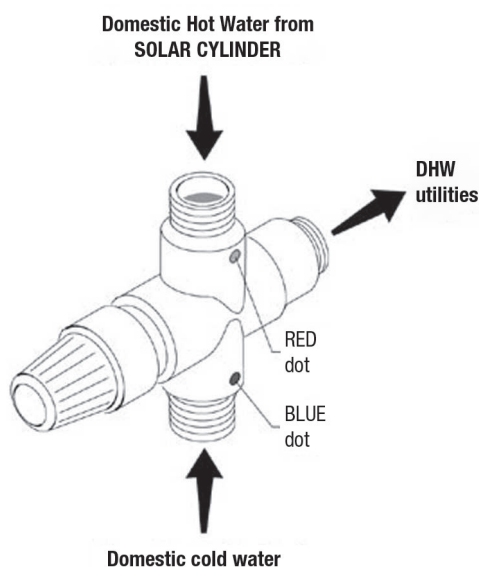

## Dimensions

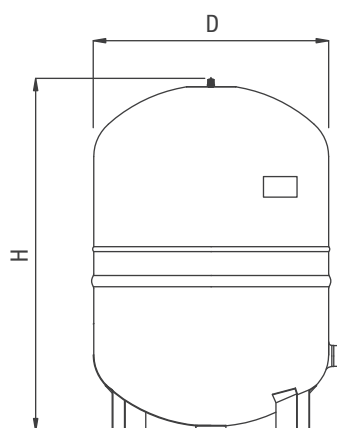

Volume	D	H
50 litres	380 mm	590 mm
100 litres	460 mm	810 mm
300 litres	650 mm	1220 mm

Accessories

# Electric heating element kit for Idra DS cylinders

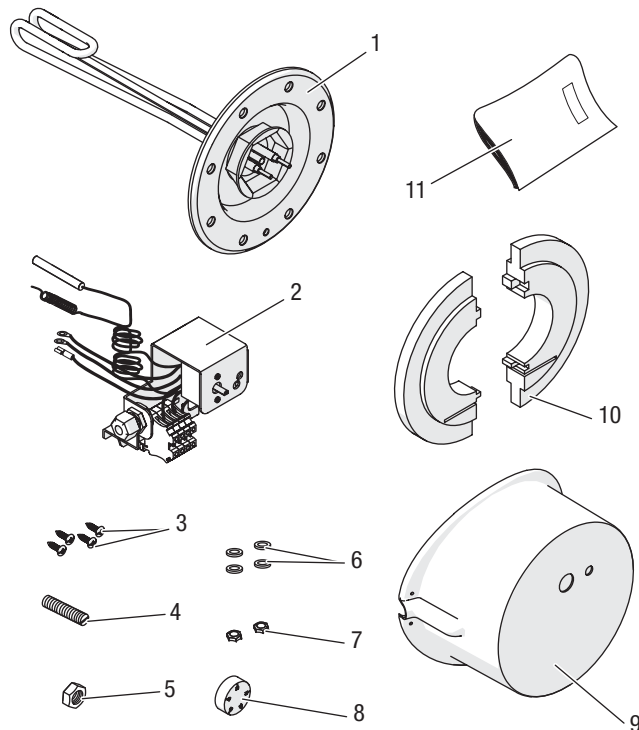

Description	Q.ty
1 Resistance	1
2 Thermostat	1
3 Cover fastening screws	4
4 Threaded pin	1
5 Thermostat fastening M8 nut	1
6 Eyelet interposition washers	4
7 Eyelet fastening nuts	2
8 Knob	1
9 Cover	1
10 Insulation	2
11 Instruction booklet	1

## Technical data

Code	Power	L	Power supply	Safety thermostat	Setting thermostat	It may be combined with a cylinder of
20119911	1500 W *	341 mm	1 x 230 V	95°C	30-70°C	200 - 300 - 430 - 550 litres
20119912	2200 W *	341 mm	1 x 230 V	95°C	30-70°C	200 - 300 - 430 - 550 litres
20119913	3000 W *	341 mm	1 x 230 V	95°C	30-70°C	200 - 300 - 430 - 550 litres
20119914	3800 W **	340 mm	3 x 400 V	98°C	9-75°C	200 - 300 - 430 - 550 litres

(\*) Single-phase  
 (\*\*) Three-phase

Set-up time (DHW 10-45°C) - Time taken by the heating element to reach the temperature set on the thermostat

Quantity of domestic water obtained in 10' with cylinder pre-heated to different temperature values (temperature set on thermostat), considering an increase of the domestic hot water temperature of 30°C between inlet and outlet (according to EN 12897).

Resistance	Cylinders					U.M.
	200	300	430	550		
1500 W	70°C	260	390	560	720	min. approx.
	60°C	200	300	430	550	min. approx.
	50°C	140	200	290	370	min. approx.
2200 W	70°C	180	270	390	490	min. approx.
	60°C	140	210	290	370	min. approx.
	50°C	90	140	200	250	min. approx.
3000 W	70°C	130	200	280	360	min. approx.
	60°C	100	150	220	270	min. approx.
	50°C	70	100	150	180	min. approx.
3800 W	75°C	120	170	250	320	min. approx.
	70°C	110	160	230	290	min. approx.
	60°C	80	102	170	220	min. approx.
	50°C	60	80	120	150	min. approx.

Resistance	Cylinders				U.M.	
	200	300	430	550		
1500 W	70°C	206	309	443	566	l
	60°C	158	237	340	343	l
	50°C	110	165	236	302	l
	70°C	206	309	443	566	l
2200 W	60°C	158	237	340	343	l
	50°C	110	165	236	302	l
	70°C	206	309	443	566	l
3000 W	60°C	158	237	340	343	l
	50°C	110	165	236	302	l
	75°C	230	345	632	920	l
	70°C	206	309	443	566	l
3800 W	60°C	158	237	340	343	l
	50°C	110	165	236	302	l

## Accessories

### Single-phase heating element wiring diagram

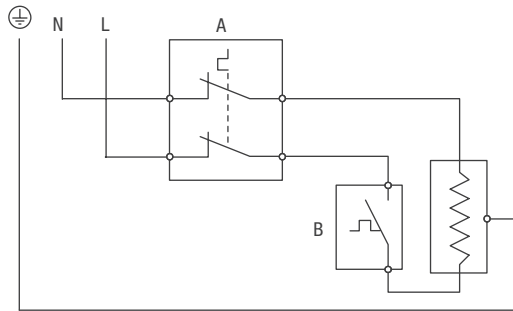

A: Safety thermostat contacts (95°C).  
B: Setting thermostat contacts (30-70°C).

### Three-phase heating element wiring diagram

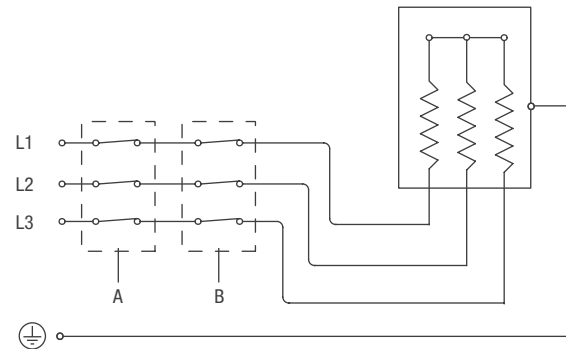

A: Safety thermostat contacts (98°C).  
B: Setting thermostat contacts (9-75°C).

It is mandatory:

1. The use of a differential magneto-thermal circuit breaker and a disconnecting switch compliant with the prevailing CEI-EN standards (contact opening of at least 3 mm).
2. to comply with the connection L (phase) - N (Neutral); Ensure that the earth conductor is approx. 2 cm longer than power supply cables;
3. With regard to the cylinder heating element power, use cables with section not less than 1.5 mm<sup>2</sup>, complete with terminal lugs.
4. Connect the device to an efficient earth system.

It is forbidden:

1. To use water pipes to earth the device.
2. To lay the power supply cables in the vicinity of any hot surfaces (delivery pipes). If there is a risk of contact with hot parts, with temperatures exceeding 50°C, a suitable cable must be utilised.

## Accessories

# SUN B and SUN C solar control units

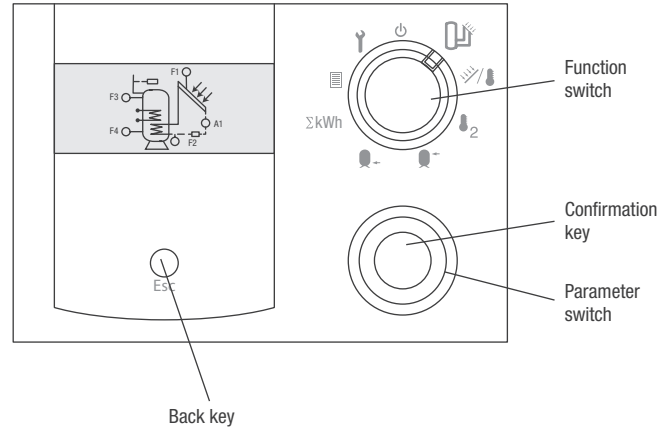

## Technical data

DIN IEC 60 038 compliant power supply	230 VAC + 10 / -15 %
Absorbed power	max 5 VA
Relay contacts	250 V, 2 A
Max. current at terminal L1	6.3 A
Protection class compliant to DIN EN 60529	IP 40
Protection class compliant to DIN EN 60730	I; overvoltage category III
Clock reserve	> 10 hours
Permissible ambient temperature during operation	0 to 50 °C
Permissible ambient temperature during storage	-20 to 60 °C
Sensor resistances	Measurement resistance PT1000, 1kΩ
Tolerance in Ohm	+/-0.2% for 0 °C
Max. permissible air relative humidity	95%
Degree of pollution (EN 60730-1)	2

## Overall operation

These regulators make it possible to manage different types of solar systems:

- System 1 - Solar regulation
- System 4 - Solar regulation with two collectors
- System 5 - Solar regulation with two cylinders - valve switching
- System 6 - Solar regulation with two cylinders - 2 loading pumps
- System 7 - Solar regulation with additional heating function
- System 8 - Solar regulation with return temperature control
- System 10 - Solar regulation with two cascade-connected cylinders
- System 11 - Solar regulation with control of two cylinder stratification zones (SUN C)
- System 12 - Solar regulation with control of three cylinder stratification zones (SUN C)

**In the following diagrams, the A3 control is managed by the SUN C control unit**

### Accessories

#### System 1 - Solar regulation

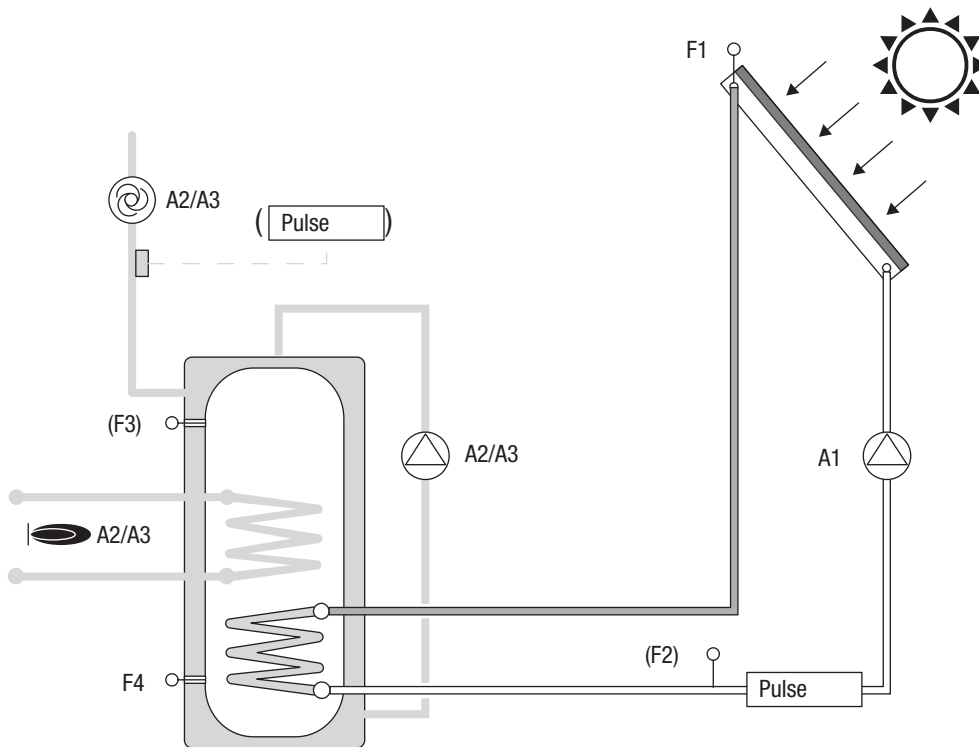

#### System 4 - Solar regulation with two collectors

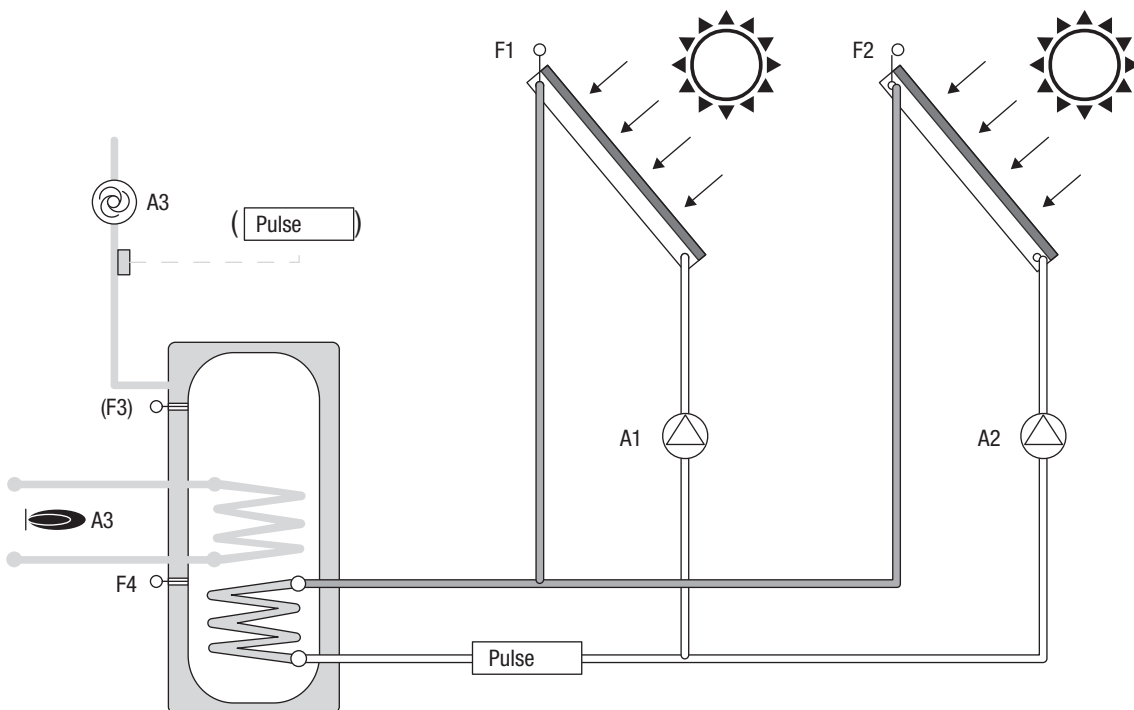

Accessories

System 5 - Solar regulation with two cylinders - valve switching

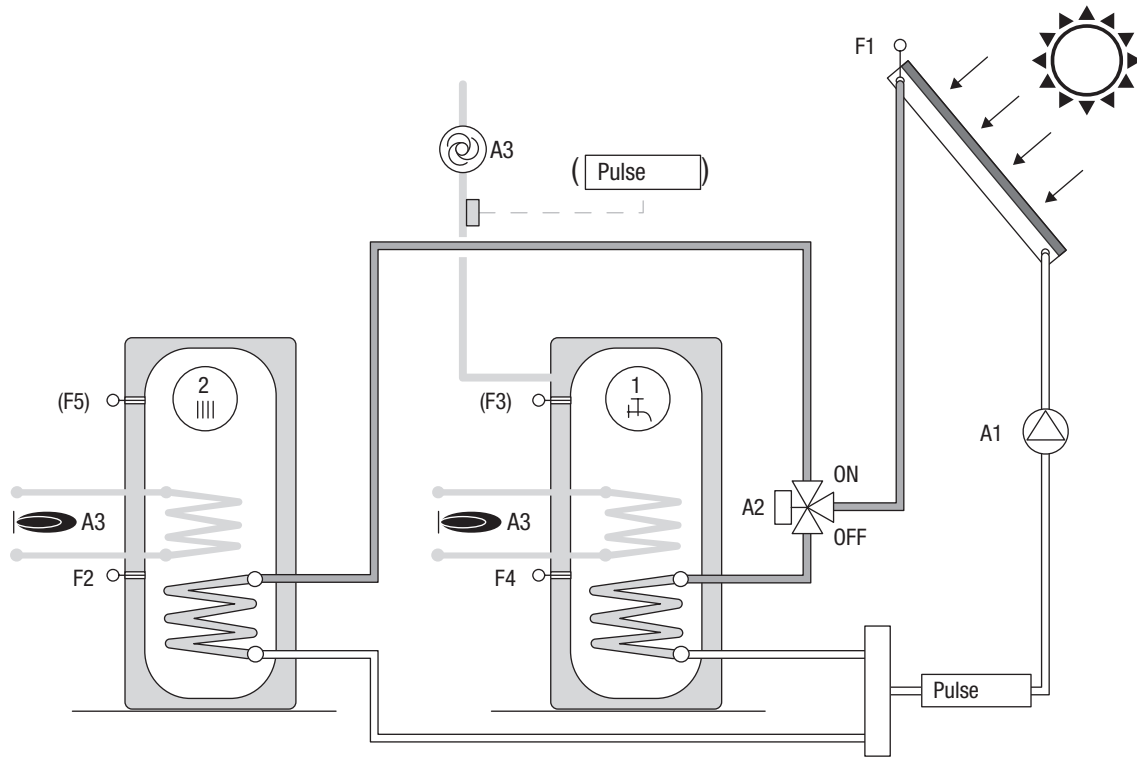

System 6 - Solar regulation with two cylinders - 2 loading pumps

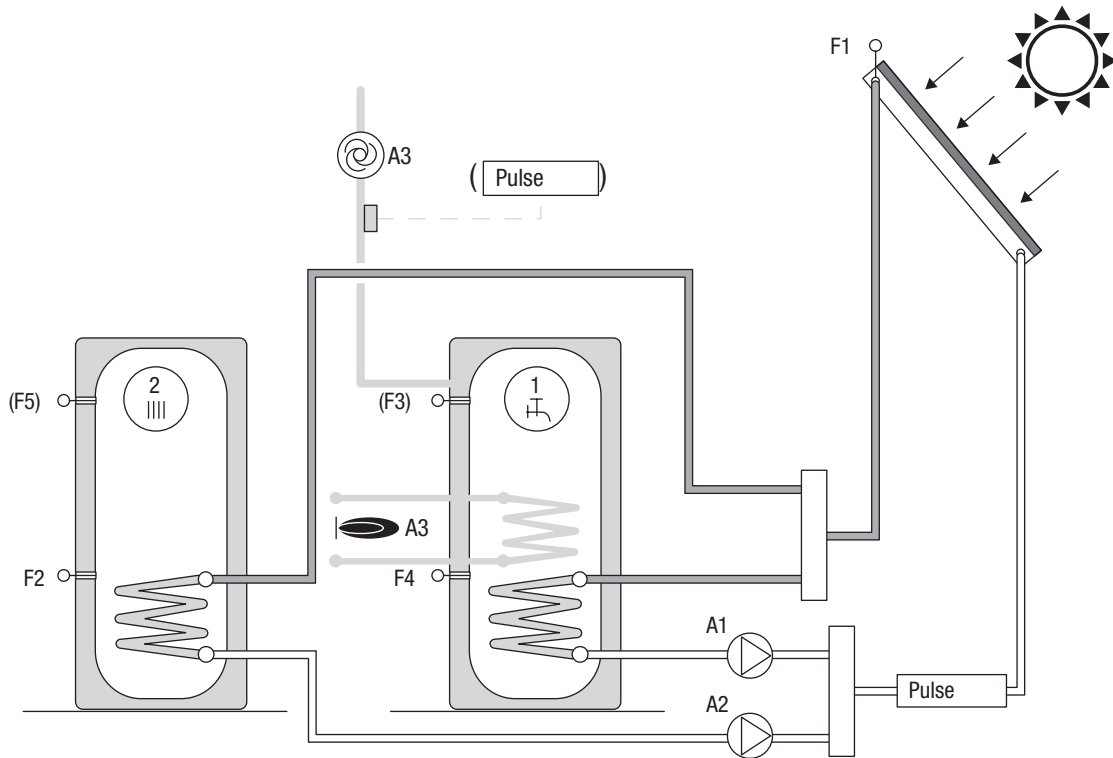

Accessories

System 7 - Solar regulation with additional heating function

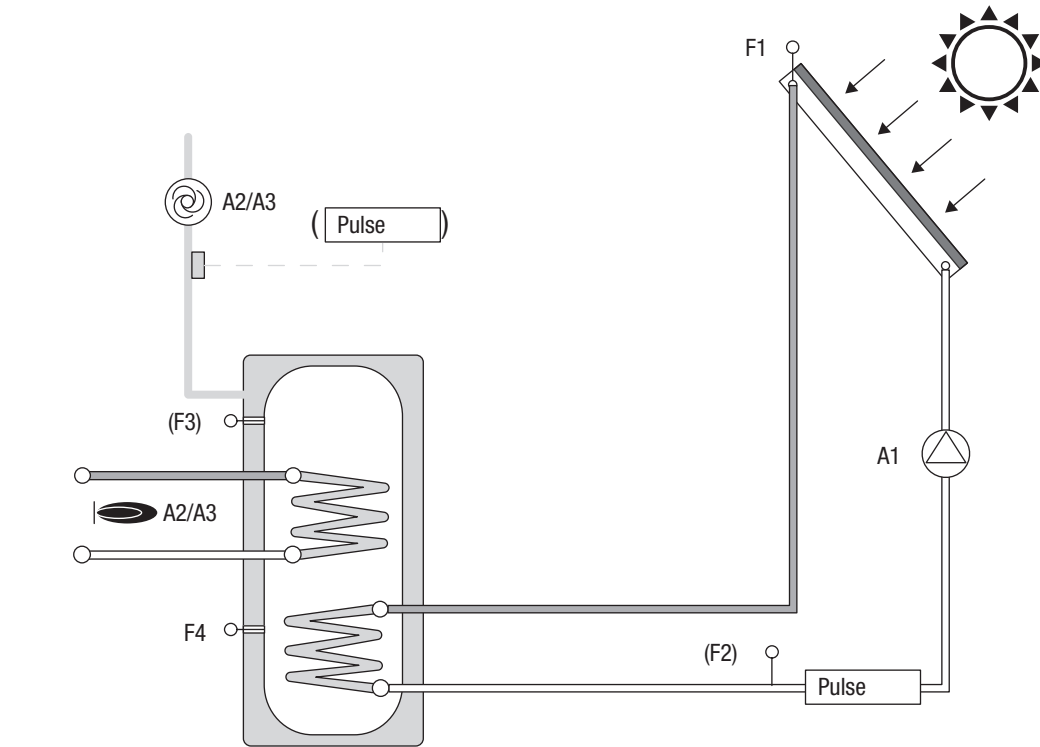

System 7 (variant) - Solar regulation with additional heating function

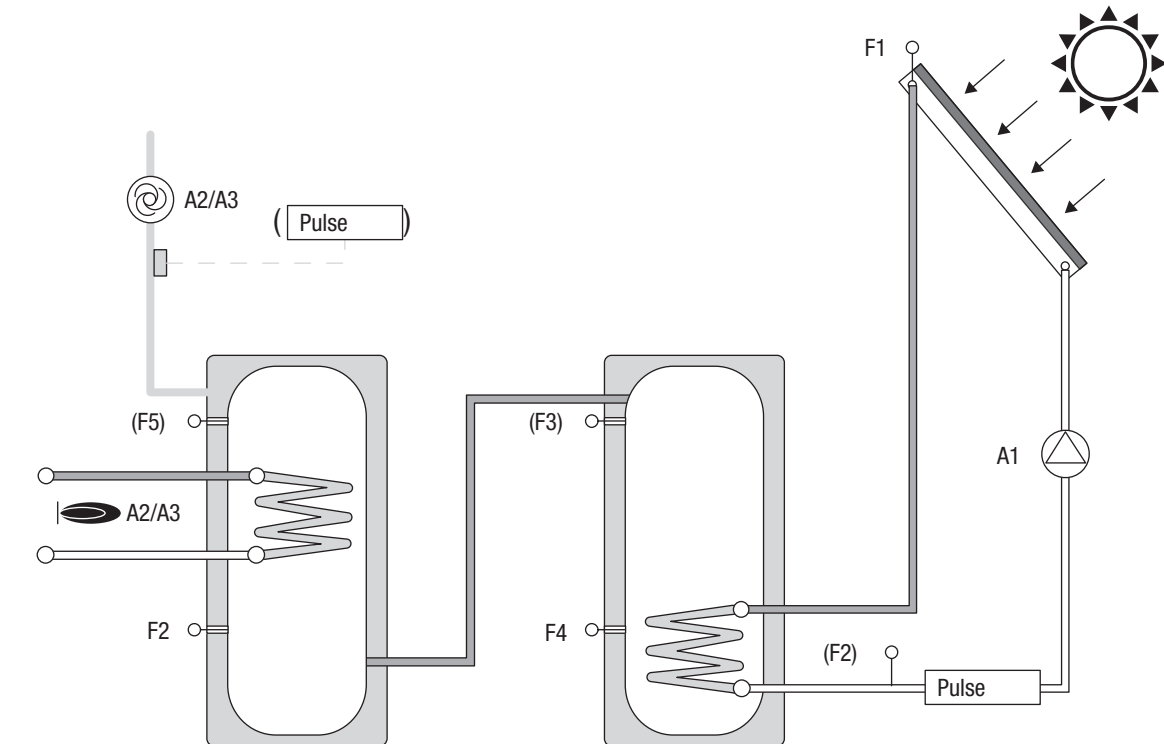

Accessories

System 8 - Solar regulation with return temperature control

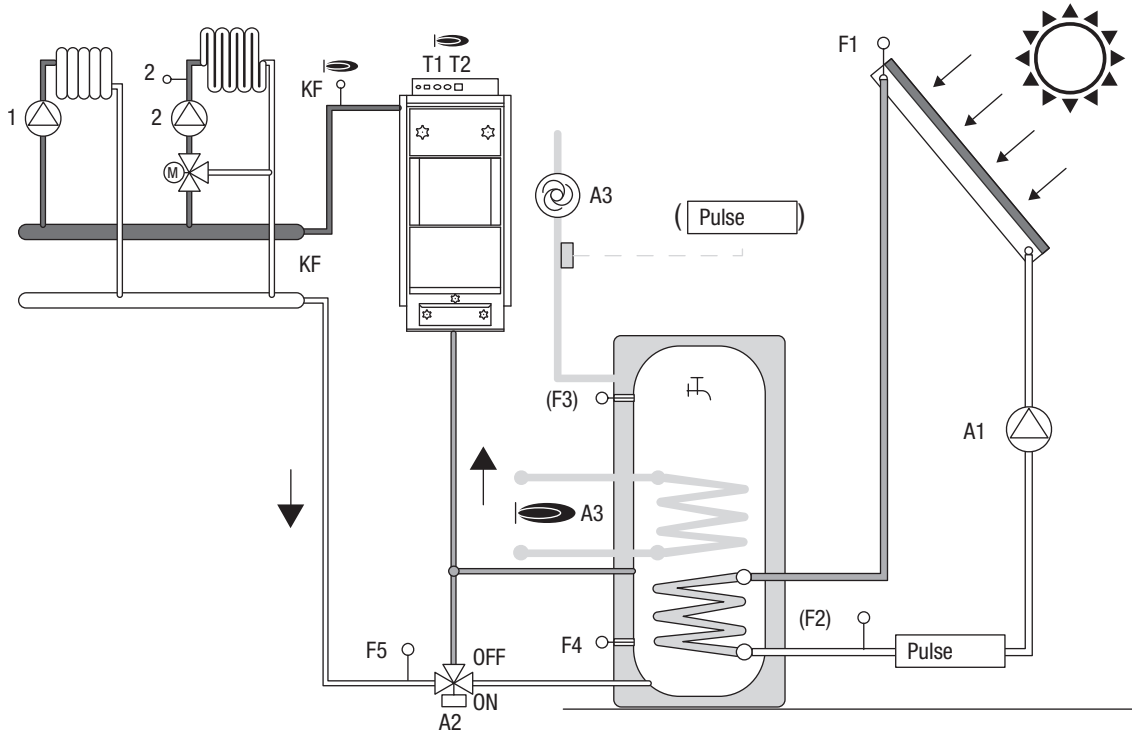

System 10 - Solar regulation with two cascade-connected cylinders

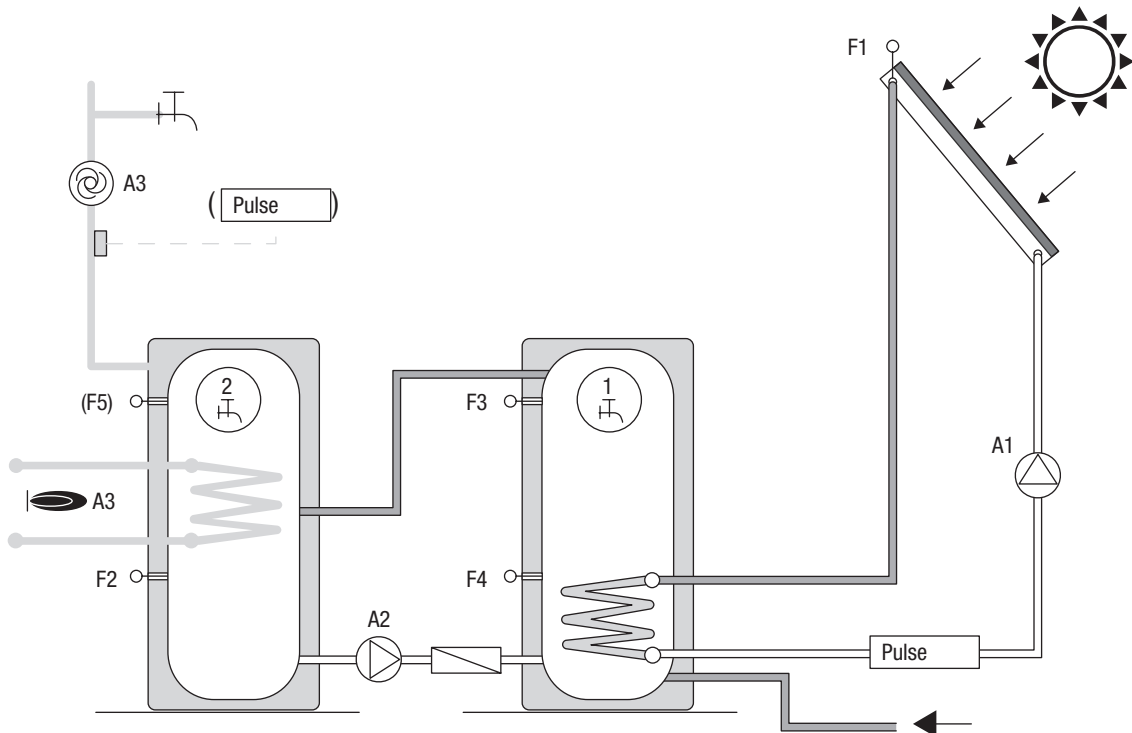

Accessories

System 11 - Solar regulation with control of two cylinder stratification zones (SUN C)

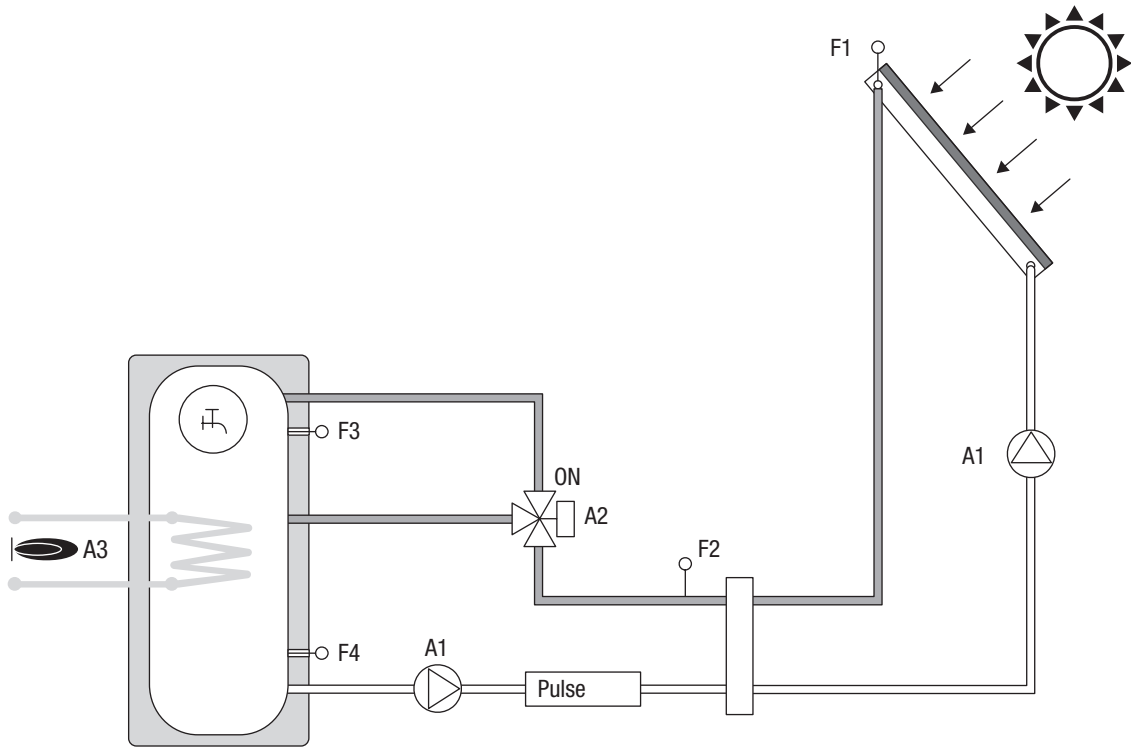

System 12 - Solar regulation with control of three cylinder stratification zones (SUN C)

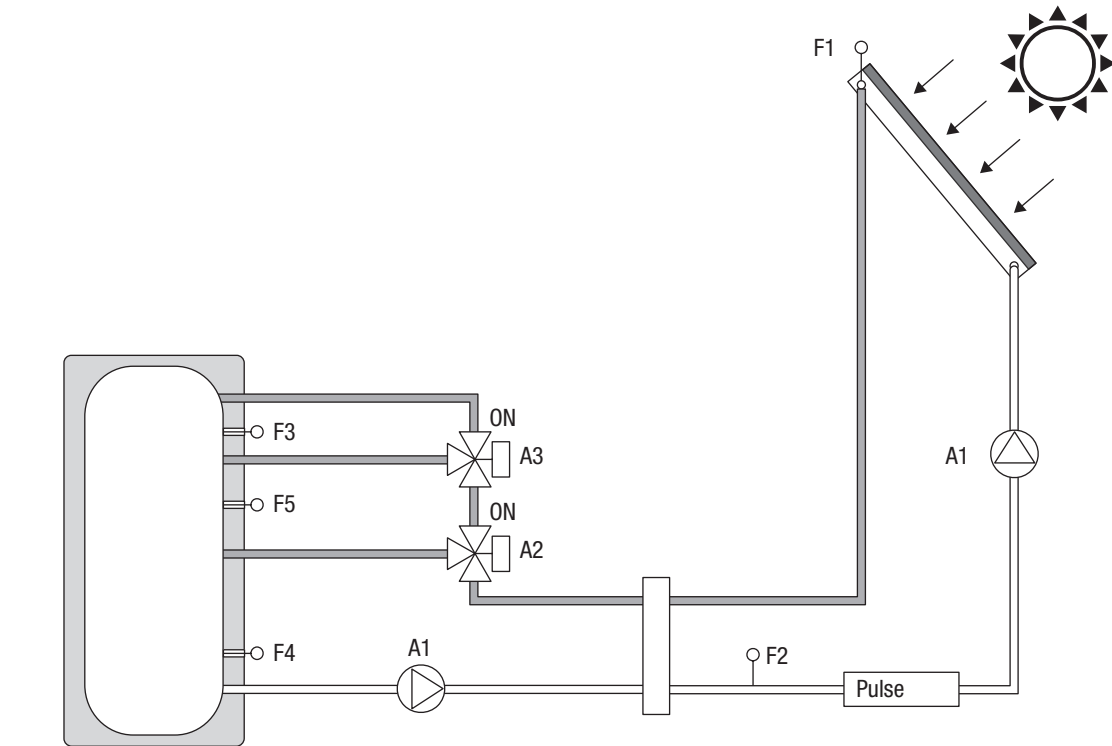

Accessories

Special functions (SUN C only)

Depending on the system selected, outputs A2 and A3 can be programmed with special functions. The desired function is set with parameter P54 for A2 and A3 separately.

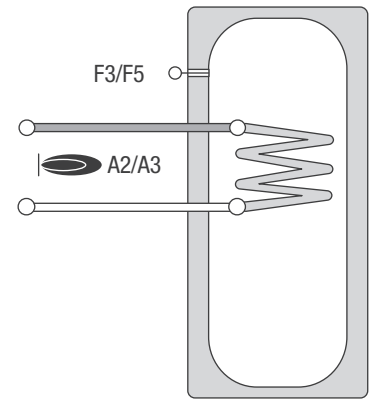

Additional heating

The special functions can be used to activate an additional heating function, e.g. via electrical heating elements:

[P54=4 (cylinder 1), P54=5 (cylinder 2)].

The additional heat generator is enabled when the temperature of cylinder F3 for cylinder 1 (F5 for cylinder 2) is lower than the setpoint temperature [P47] set at [P34] (in the solar balance of [P47]-[P52]).

It is disabled as soon as the cylinder temperature exceeds the setpoint temperature.

This function is active during the enable time [P07-P08].

Circulation pump

A circulation pump can be activated via the special functions:

[P54=1, P54=2, P54=3].

P54=1 ➔ The circulation pump is continuously switched on during the enable time [P09-P10].

P54=2 ➔ In the event of a short circuit, the circulation pump is switched on at the pulse input for the set switch-on time P55 in minutes. A new switch-on is only possible after the expiration of the P56 set block time, in minutes.

The switch-on only takes place during the enable time [P09-P10].

P54=3 ➔ activation during switch-on of the anti-legionella function.

P54=1, P54=2, P54=3

P54=3

Return temperature increase

Through the special functions it is possible to activate an increase of the return temperature:

[P54=6 (cylinder 1; F4), P54=7 (cylinder 2; F2)].

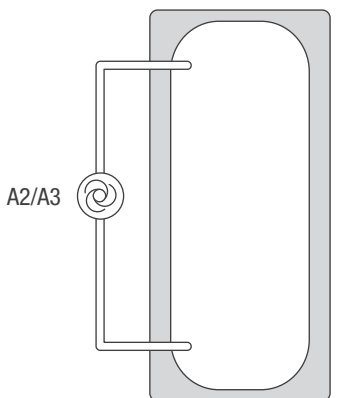
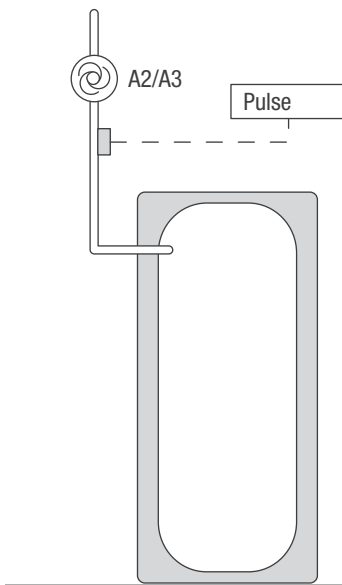

The return flow of the heating system is conducted through the storage tank and thus heated.

The switch-on through A2 occurs when the temperature in the cylinder exceeds the return temperature (F5) of the second activation threshold [P32].

The valve is closed when the cylinder temperature is below the return flow temperature F5 + second deactivation threshold [P33].

**Accessories**

# Evosol

The solar regulator EVOSOL is suitable for regulating a solar integration system: it controls the heat transfer from the solar collectors to a storage system. It is responsible for the operation of the pump using the information collected from temperature sensors. It can also control the integration.

The solar regulator provides 9 system layouts and advanced functions, such as adjustment of pump speed, thermal disinfection function, protection of solar collectors against overtemperature and too low temperatures (anti-freeze function), and operating hours counter.

The solar regulator is provided with 4 inputs for temperature sensors, 2 NTC 10K @ 25°C (B 3435) to be installed in storage system 1, and 2 PT1000 to be installed in the solar collectors or in the second storage system, 1 static control output for pumps or standard 230 VAC 3-way valves, 1 Volt-free dry contact and 2 PWM outputs for modulating pumps.

**Compliance to**

EVOSOL solar regulators are compliant with:

- EN 61000-6-1:2007.
- EN 61000-6-3:2007/A1:2011.
- EN 61000-3-2:2014.
- EN 61000-3-3:2013.
- EN 60335-1:2012.
- Electromagnetic Compatibility Directive 2014/30/EU.
- Low Voltage Directive 2014/35/EU.
- Machine Directive 2006/42/EC.
- Directive 93/42/EEC concerning medical devices.
- Directive 2011/65/EU on the restriction of the use of certain hazardous substances in electrical and electronic equipment.

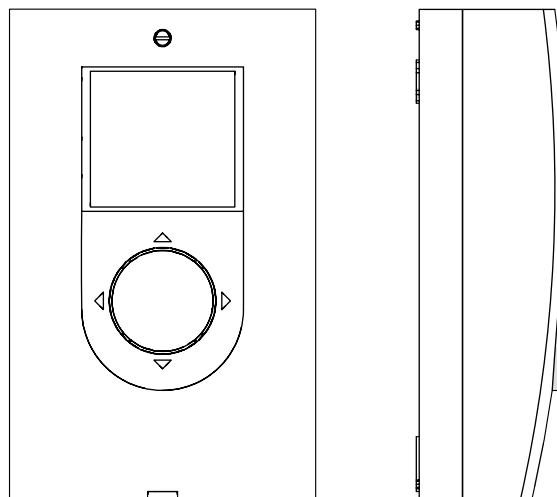

Boiler with compact solar station

The regulator is already mounted as standard on the following products:

Solar station

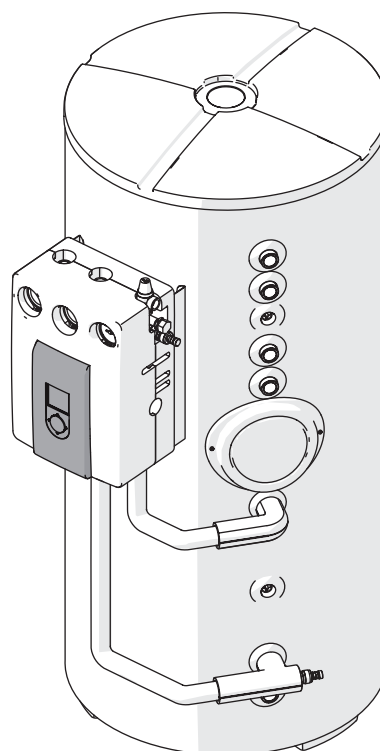
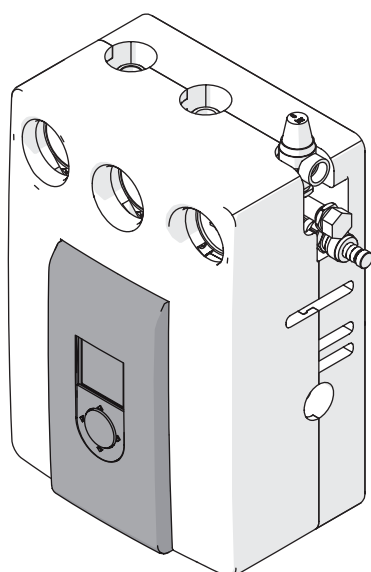

## Accessories

## Technical data

Power supply		230Vac +10 -15% 50-60Hz
Protection (fuse)		F 3.15A - 250V - 5x20mm - rapid
Maximum absorption in stand-by		3W
Maximum total absorption allowed		600W
Class of protection from external agents		IP20
Outputs	U1	no. 1 static output 230Vac 1.3A Max @ $\cos \varphi > 0.5$
	U2	no. 1 Volt-free dry contact output 230Vac 1A Max
Pilot outputs	CN6	no. 2 static outputs PWM at 24VDC 25mA Max
Temperature sensors	S1-S4(S6)	PT1000 class B
	S2-S3	NTC 10K @ 25°C ( $\beta$ 3435)
Conversion accuracy		$\pm 2^\circ\text{C}$
Interconnection with other control units		RS-485 line (Modbus RTU protocol)
Maximum number of interconnected devices		32
Maximum interconnection length (sum of nodes)		500 m shielded twisted pair cable AWG 22-24 @ 9600 Baud transmission rate
Termination at control unit interconnection beginning and end		via jumper position J4
Net weight		300g

## Structure

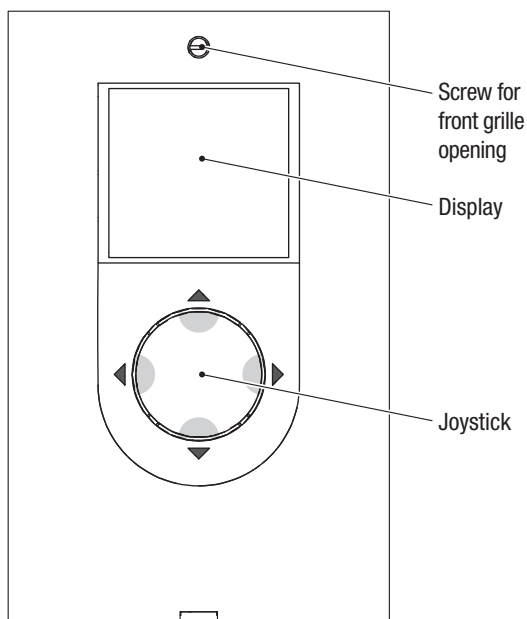

## Dimensions

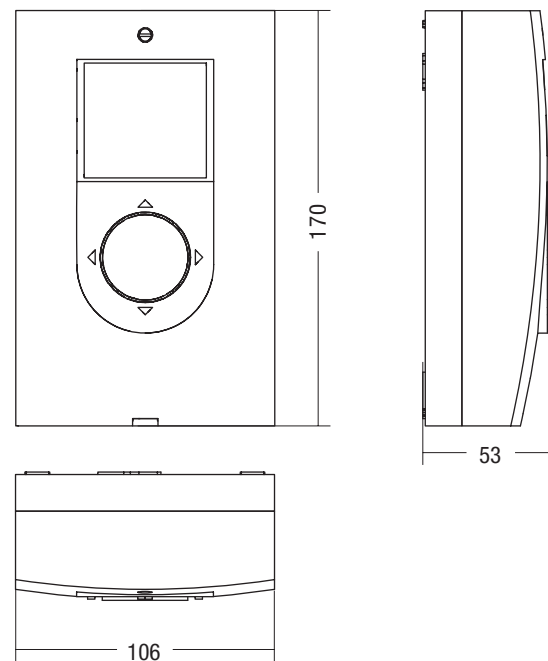

Accessories

Wiring diagram

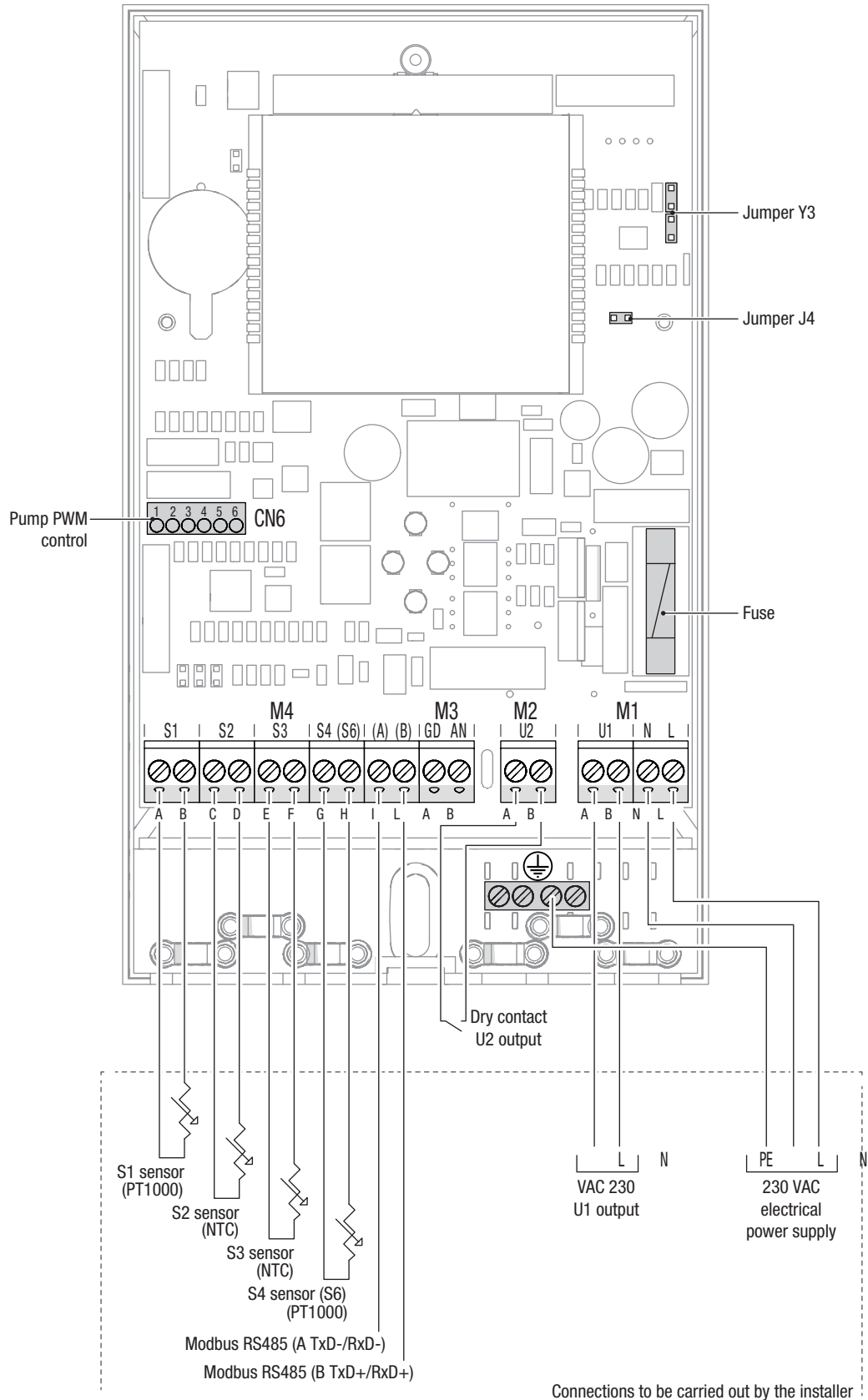

## Accessories

### M4 terminal board connections

- sensor S1 PT1000 (collector temperature sensor 1).
- S2 NTC sensor (lower storage tank temperature sensor 1).
- S3 NTC sensor (upper storage tank temperature sensor 1).
- S4 PT1000 sensor (storage temperature sensor 2) or sensor.
- S6 PT1000 (collector temperature sensor 2; heating system return temperature sensor).

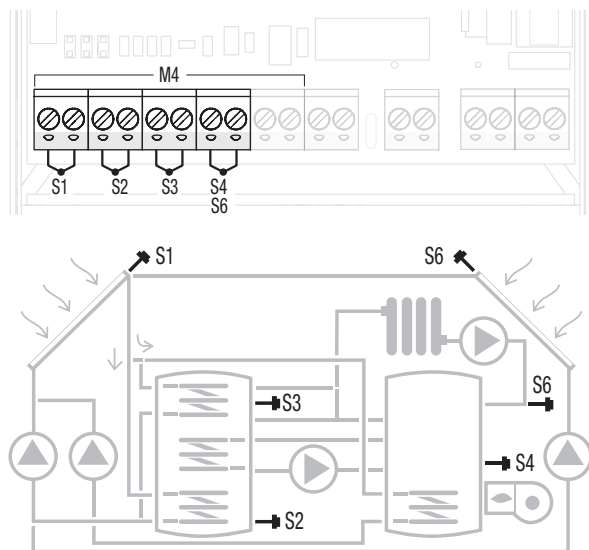

The connected temperature sensors can be controlled with a multimeter-tester. The correspondence between temperature and resistance is shown in the following tables.

°C	Ω	°C	Ω
-10	961	55	1213
-5	980	60	1235
0	1000	65	1252
5	1019	70	1271
10	1039	75	1290
15	1058	80	1309
20	1078	85	1328
25	1097	90	1347
30	1117	95	1366
35	1136	100	1385
40	1155	105	1404
45	1175	110	1423
50	1194	115	1442

°C	Ω	°C	Ω	°C	Ω	°C	Ω
0	27200	28	8947	56	3433	84	1492
1	26061	29	8625	57	3326	85	1451
2	24976	30	8316	58	3222	86	1412
3	23942	31	8020	59	3122	87	1373
4	22957	32	7763	60	3026	88	1336
5	22017	33	7463	61	2934	89	1300
6	21120	34	7201	62	2844	90	1266
7	20265	35	6950	63	2758	91	1232
8	19449	36	6709	64	2674	92	1199
9	18670	37	6477	65	2594	93	1167
10	17926	38	6254	66	2516	94	1137
11	17216	39	6040	67	2441	95	1107
12	16537	40	5835	68	2369	96	1078
13	15889	41	5637	69	2299	97	1050
14	15270	42	5448	70	2232	98	1023
15	14678	43	5265	71	2166	99	997
16	14112	44	5090	72	2103	100	971
17	13571	45	4921	73	2043	101	947
18	13053	46	4758	74	1984	102	923
19	12558	47	4602	75	1927	103	900
20	12084	48	4452	76	1872	104	877
21	11630	49	4307	77	1819	105	855
22	11195	50	4168	78	1767	106	834
23	10780	51	4033	79	1717	107	813
24	10381	52	3904	80	1669	108	793
25	10000	53	3780	81	1623	109	774
26	9634	54	3660	82	1578	110	755
27	9283	55	3544	83	1534		

### Connection to PWM modulating pumps

#### Regulator added to another product

The solar regulator already added to another product can handle a further modulating pump (as an alternative to the standard 230Vac pump) connecting the pump control to connector CN6 using the wiring (CB) available as an accessory. The power part must be connected to terminal board M2 (output U2).

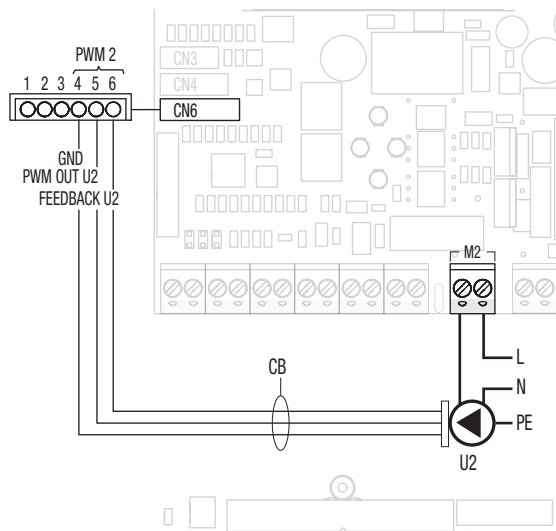

## Accessories

### PWM control signals

The pump must be controlled via a PWM (pulse width modulation) low-voltage digital signal. The speed changes according to the input signal as indicated in the paragraph "PWM input signal". Here below are the main characteristics required of the PWM signal.

### PWM low-voltage digital signal

The PWM square wave signal was designed for a frequency interval between 100 and 4000 Hz. The PWM signal is used to set circulation pump speed.

### Example of Duty cycle

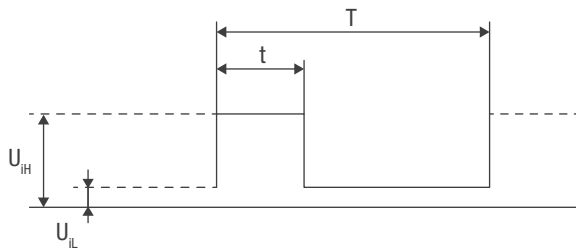

- T Period
- d Duty cycle (t/T)
- $U_{iH}$  High voltage level of the input signal
- $U_{iL}$  Low voltage level of the input signal
- $I_{iH}$  Current intensity of the input signal

Example	Evaluation
T = 2 ms (500 Hz)	$U_{iH} = 4-24\text{ V}$
t = 0.6 ms	$U_{iL} \leq 1\text{ V}$
d % = $100 \times 0.6 / 2 = 30\%$	$I_{iH} \leq 10\text{ mA}$ (dependent on $U_{iH}$ )

### PWM input signal

With a low input value (<5 % PWM), the pump cannot start. The pump stops when input signal is 5 to 8% of PWM signal or when PWM signal is not present, for safety reasons. If the pump receives no input, due for instance to failure of the signal cable, it will stop in order to avoid solar system overheating.

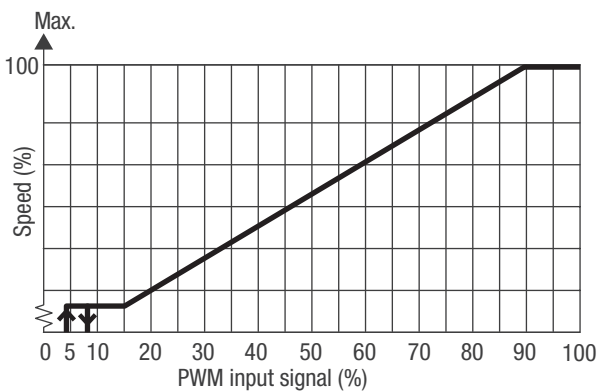

### Electronic circuit

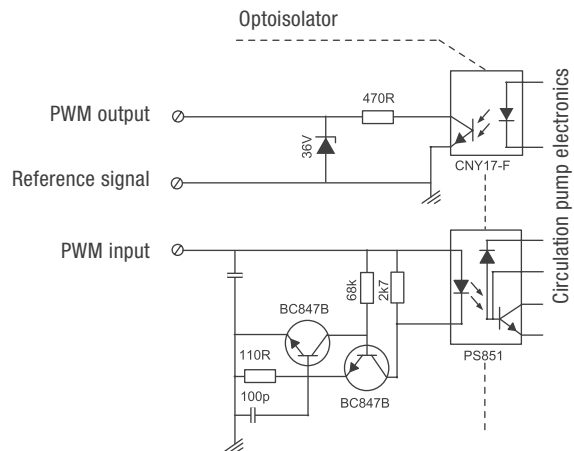

### Technical data

Maximum power	Symbol	Value
PWM input frequency	f	100-4000 Hz
Stand-by consumption		< 1 W
High voltage level of the input signal	$U_{iH}$	4-24 V
Low voltage level of the input signal	$U_{iL}$	< 1 V
Current intensity of the input signal	$I_{iH}$	< 10 mA
Input duty cycle	PWM	0-100%

### Modbus data transmission

The solar regulator is equipped with 1 terminal for data transmission and reception through MODBUS RTU protocol on RS-485 line. Pay attention to the polarity of terminals A and B.

M4 terminal board connections:

- MODBUS RS485 ([A] TxD-/RxD-)
- MODBUS RS485 ([B] TxD+/RxD+)

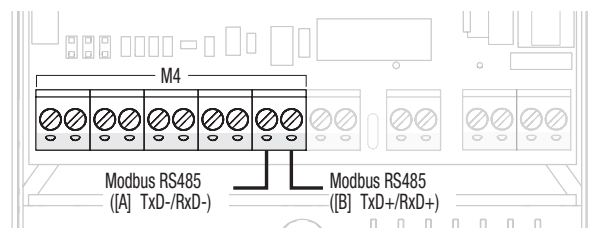

## Accessories

### User Interface

The solar regulator is controlled via the 4-button directional joystick.

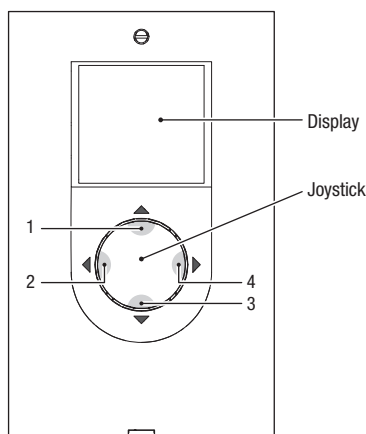

- Pressing "◀" (2) for a few seconds you can enter the password to access the parameters intended for the installer.
- Pressing "◀" (2) or "▶" (4) scrolls through the adjustment/display parameters; while changing a parameter, pressing it for a few seconds allows you to confirm the set value and return to the parameter list.
- Pressing "▲" (1) for a few seconds you can make the displayed parameter editable and increase the value.
- Press "▼" (3) to decrease the value of the selected parameter.
- Pressing "▼" (3) for a few seconds allows you to change the display time, day and language.

### Display

The solar regulator has a 2.8-inch backlit LCD display. The display can be divided into 3 display zones:

1. System diagrams zone
2. Symbols zone
3. Parameters zone

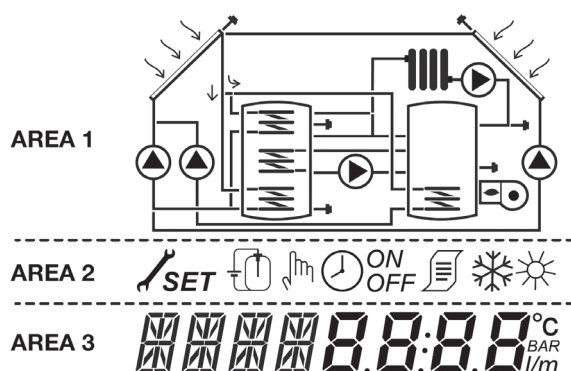

#### 1. System diagrams zone

The area of the system diagrams shows the active diagram saved by the SYSN parameter. The symbols displayed flash, remain fixed or disappear depending on the current system status.

#### 2. Symbols zone

The symbols zone indicates the system status.

#### 3. Parameters zone

In the lower part of the display you can see the parameters of the solar regulator; the abbreviation of the parameter is on the left side while the value is on the right side, with the corresponding unit of measurement or the parameter setting.

During stand-by the display is turned off with an indication of the temperature of the upper part of the storage (S3). Press any button to view the display.

### Icons displayed

	Solar Collector
	Pump The symbol flashes during operation
	Storage tank
	Supplementary system The symbol flashes during operation
	Radiator/heating system
	Storage coil
	Temperature sensor The symbol flashes when the relevant display parameter is selected
	Alarm presence (maintenance request)
	Anti-freeze symbol
	Collector overtemperature
<b>SET</b>	Parameter setting When the displayed parameter can be modified, the steady message SET appears on the display; when you enter the editing mode, the message begins to flash until confirmation
	Hourly programming set to "automatic"
	Manual mode (it enables the forced management of the outputs U1/U2)
	Energy calculation (not used)
	These symbols begin to flash when the thermal disinfection (anti-legionella) function is active

Accessories

System diagrams

System 1 - Solar heating with 1 storage system

The system works on the temperature difference between solar collector (S1) and the low zone of storage system (S2) to maintain the storage system at the temperature set in parameter no.59 (B1LO - SETPOINT BOILER1 LOW).  
 If the difference S1-S2 is greater than or equal to the value set in parameter no.8 (ON12), the pump connected to output U1 is activated.  
 The pump (U1) remains on until the temperature difference between S1 and S2 reaches the value set in parameter no.9 (OF12).

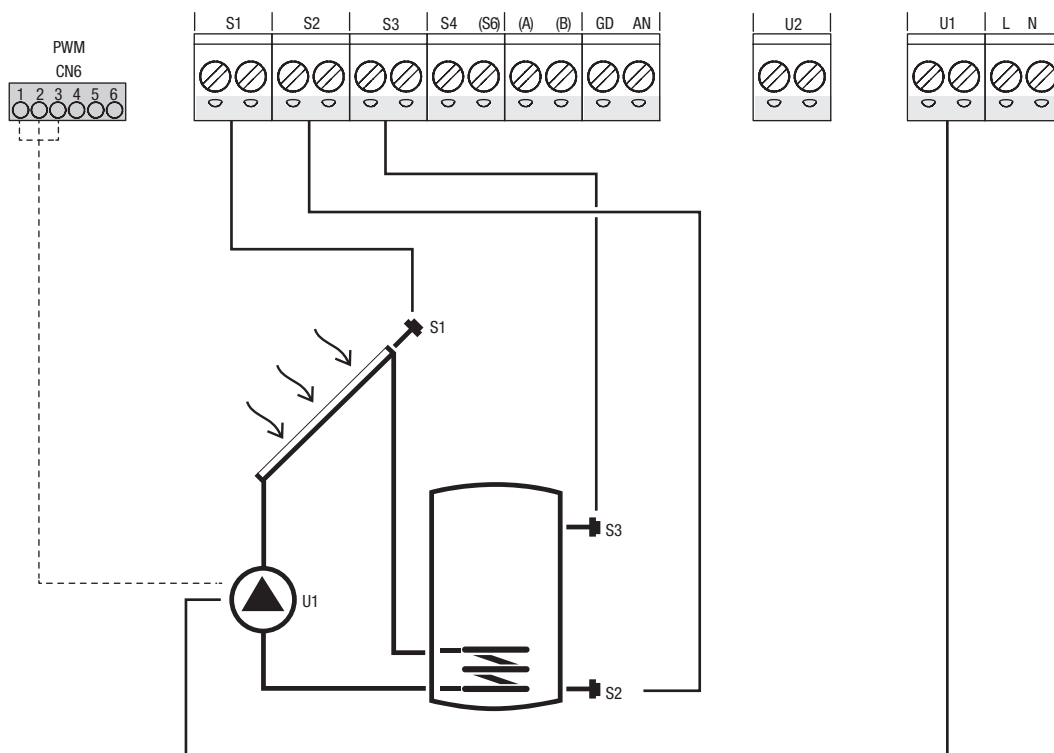

- SET Parameter can be changed
- / Parameter or value not used
- R/O Parameter available for modbus in read-only mode
- R/W Parameter available for modbus in read-write mode

- S Temperature sensor
- U pump/valve managed by regulator

Accessories

System 2 - Solar heating with heat transfer

The system works on the temperature difference between solar collector (S1) and the low zone of the first storage system (S2) to maintain the storage 1 temperature set in parameter no. 59 (B1LO - SETPOINT BOILER1 LOW). It also works on the temperature difference between the high zone of the first storage system (S3) and the low zone of the second storage system (S4) to maintain the storage 2 temperature set in parameter no. 64 (B2LO - SETPOINT BOILER2 LOW).

If the difference S1-S2 is greater than or equal to the value set in parameter no.8 (ON12), the pump connected to output U1 is activated. The pump (U1) remains on until the temperature difference between S1 and S2 reaches the value set in parameter no.9 (OF12).

If the difference S3-S4 is greater than or equal to the value set in parameter no.16 (ON34) and sensor S3>ST12, the pump connected to output U2 is activated.

The pump (U2) remains on until the temperature difference between S3 and S4 reaches the value set in parameter no.17 (OF34).

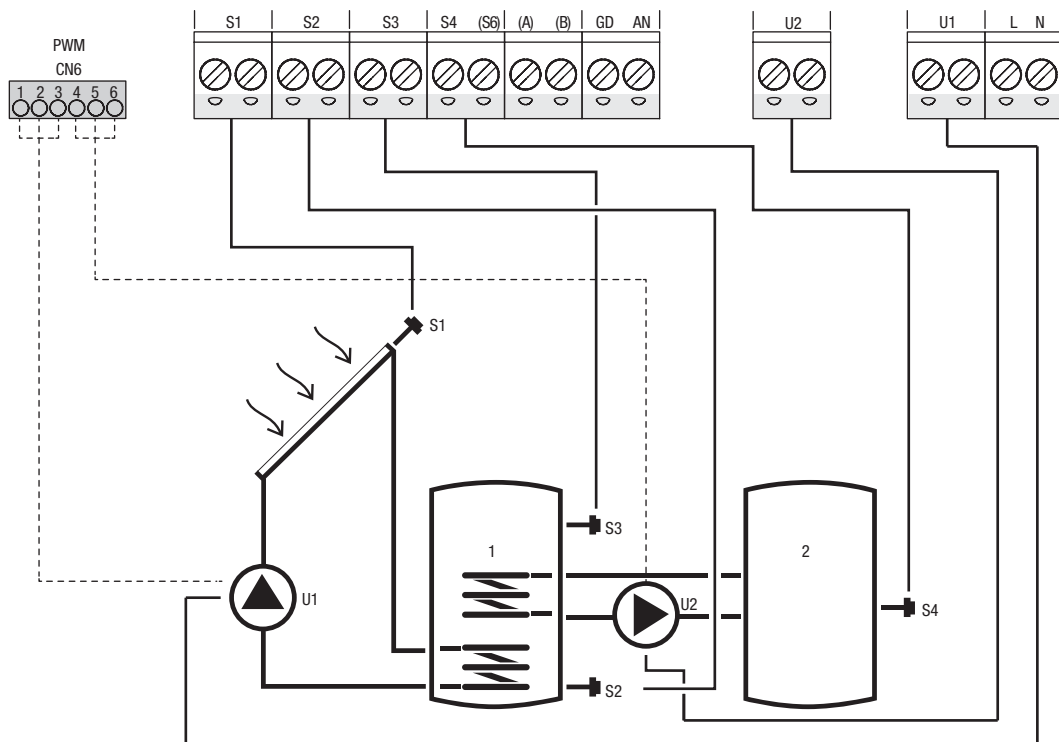

- SET Parameter can be changed
- / Parameter or value not used
- R/O Parameter available for modbus in read-only mode
- R/W Parameter available for modbus in read-write mode

- S Temperature sensor
- U pump/valve managed by regulator

### Accessories

#### System 3 - Solar system with additional heating

The system works on the temperature difference between solar collector (S1) and the low zone of the storage system (S2) to maintain the storage temperature set in parameter no. 59 (B1LO - SETPOINT BOILER1 LOW).

A supplementary heating, activated through time schedule with parameters no. 103-109 (DAYn), is used as supplement to the solar collector. If the difference S1-S2 is greater than or equal to the value set in parameter no.8 (ON12), the pump connected to output U1 is activated. The pump (U1) remains on until the temperature difference between S1 and S2 reaches the value set in parameter no.9 (OF12).

Through the time programming set in the DAYn parameters, it is possible to use an additional system to integrate the heat exchange between the solar collectors and the storage tank.

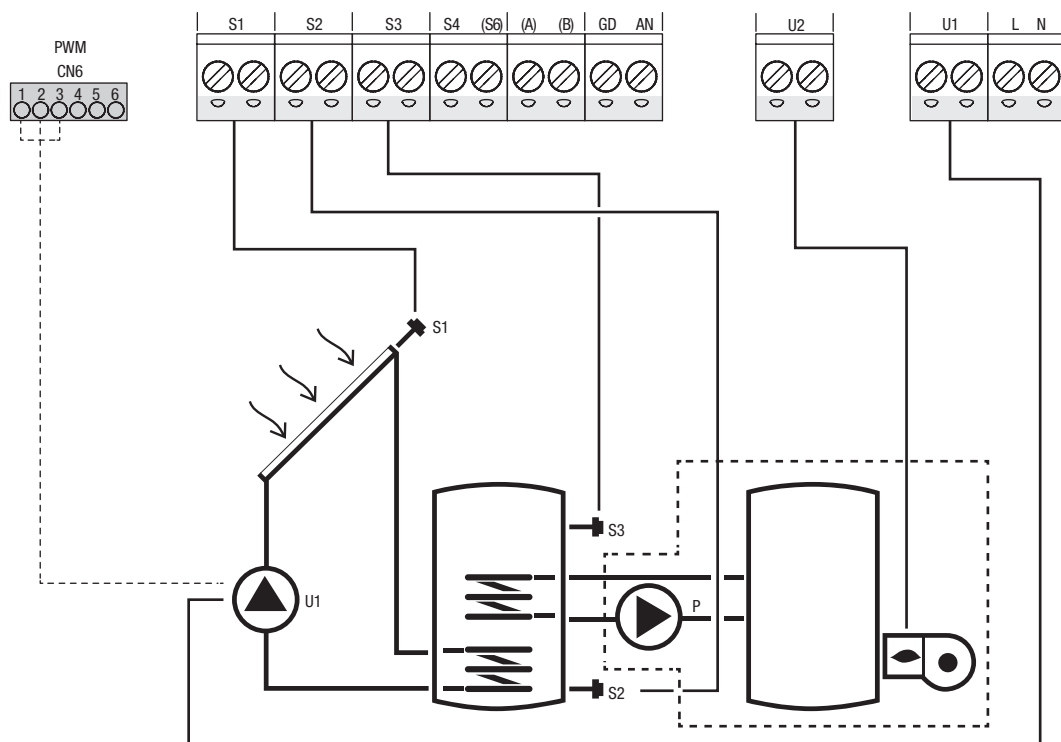

- SET Parameter can be changed
- / Parameter or value not used
- R/O Parameter available for modbus in read-only mode
- R/W Parameter available for modbus in read-write mode

- S Temperature sensor
- U pump/valve managed by regulator
- P Pump
- Integration system

### Accessories

#### System 4 - Solar system with stratified filling of the storage system

The system makes it possible to heat two storage zones at different times, allowing the choice of which of the two zones has time priority over the other. Through parameter no. 67 (PZB1) it is possible to change priority of the zone to be heated (high zone by default).

The system works on the temperature difference between solar collector (S1) and the storage system both to heat the high zone (S3) and maintain the temperature set in parameter no. 56 (B1HI- SETPOINT BOILER1 HIGH) as well as to heat the low zone (S2) and maintain the temperature set in parameter no. 59 (B1LO- SETPOINT BOILER1 LOW). Thus, it is possible to manage the storage system heating, controlling the stratification between high zone (S3) and low zone (S2).

If the difference S1-S3 is greater than or equal to the value set in parameter no. 10 (ON13), the pump connected to output U1 is activated and the solenoid valve connected to output U2 changes over to allow for circulation between the solar collector and the storage system high zone (contact of output U2 closed).

The pump (U1) remains on until the difference reaches the value set in parameter no.11 (OF13).

If the difference S1-S3 is greater than or equal to the value set in parameter no. 8 (ON12), the pump connected to output U1 is activated and the solenoid valve connected to output U2 changes over to allow for circulation between the solar collector and the storage system low zone (contact of output U2 open).

The pump (U1) remains on until the temperature difference between S1 and S2 reaches the value set in parameter no.9 (OF12).

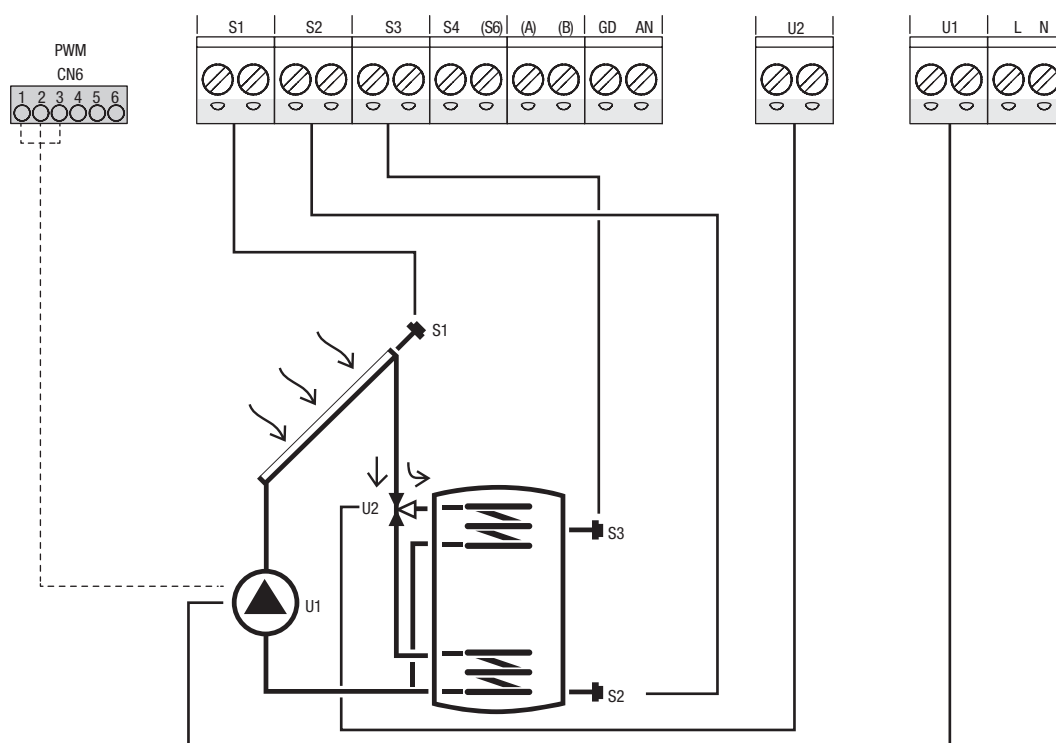

- SET Parameter can be changed
- / Parameter or value not used
- R/O Parameter available for modbus in read-only mode
- R/W Parameter available for modbus in read-write mode

- S Temperature sensor
- U pump/valve managed by regulator

**Accessories**

**System 5 - Solar system with 2 tanks and priority logic**

The system works on the temperature difference between solar collector (S1) and the low zone of the first storage system (S2) to maintain the storage 1 temperature set in parameter no. 59 (B1LO) (SETPOINT BOILER1 LOW). The system works on the temperature difference between solar collector (S1) and the low zone of the second storage system (S4) to maintain the storage 2 temperature set in parameter no. 64 (B2LO) (SETPOINT BOILER2 LOW).

If the difference S1-S2 is greater than or equal to the value set in parameter no. 8 (ON12), the pump connected to output U1 is activated and the solenoid valve connected to output U2 changes over to allow for circulation between the solar collector and the storage system low zone 1 (contact of output U2 open).

The pump (U1) remains on until the temperature difference between S1 and S2 reaches the value set in parameter no.9 (OF12).

If the difference S1-S4 is greater than or equal to the value set in parameter no. 12 (ON14), the pump connected to output U1 is activated and the solenoid valve connected to output U2 changes over to allow for circulation between the solar collector and the storage system low zone 2 (contact of output U2 closed).

The pump (U1) remains on until the temperature difference between S1 and S4 reaches the value set in parameter no.13 (OF14).

It is possible to change the priority of the storage system to be heated with parameter no.53 (PRBO) (the first storage system is set by default).

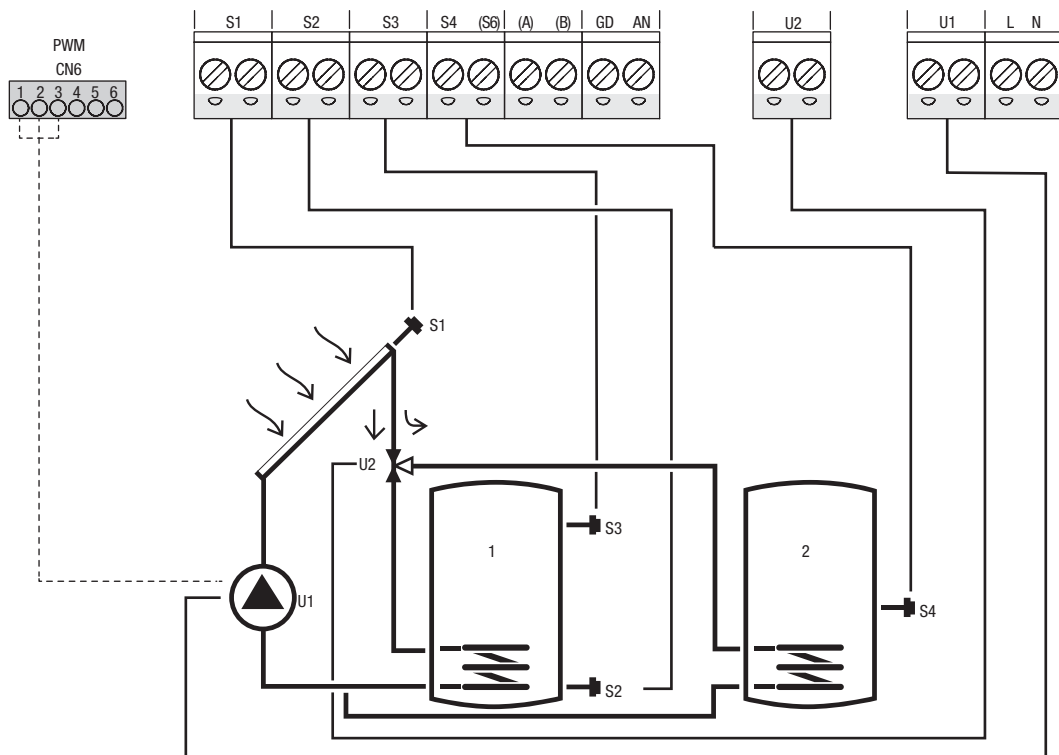

- SET Parameter can be changed
- / Parameter or value not used
- R/O Parameter available for modbus in read-only mode
- R/W Parameter available for modbus in read-write mode

- S Temperature sensor
- U pump/valve managed by regulator

Accessories

System 6 - Solar system with 2 tanks and operation with pumps

The system works on the temperature difference between solar collector (S1) and the low zone of the first storage system (S2) to maintain the storage 1 temperature set in parameter no. 59 (B1LO - SETPOINT BOILER1 LOW). The system works on the temperature difference between solar collector (S1) and the low zone of the second storage system (S4) to maintain the storage 2 temperature set in parameter no. 64 (B2LO - SETPOINT BOILER2 LOW).

If the difference S1-S2 is greater than or equal to the value set in parameter no.8 (ON12), the pump connected to output U1 is activated.

The pump (U1) remains on until the temperature difference between S1 and S2 reaches the value set in parameter no.9 (OF12).

If the difference S1-S4 is greater than or equal to the value set in parameter no.12 (ON14), the pump connected to output U2 is activated.

The pump (U2) remains on until the temperature difference between S1 and S4 reaches the value set in parameter no.13 (OF14).

The system works with priority logic (alternating between the two storage zones) and it is possible to change the priority of the storage to be heated first with the parameter no. 53 (PRBO) (by default the first storage zone has priority).

NOTE: as second pump (U2), it is recommended to use a pump with PWM.

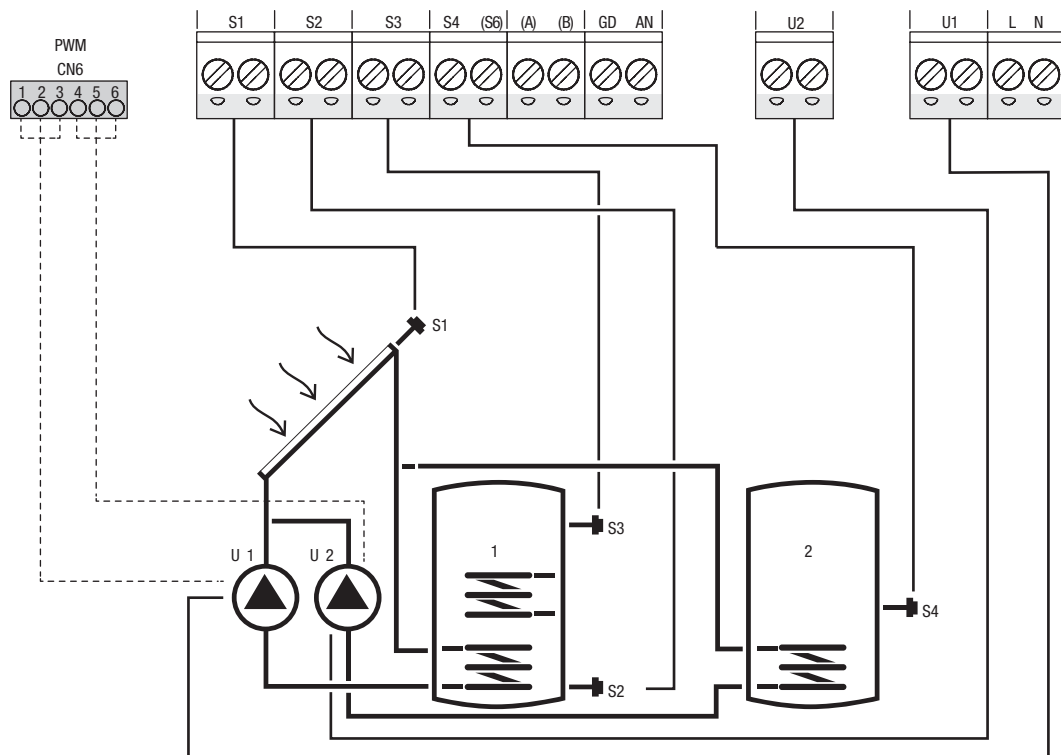

- SET Parameter can be changed
- / Parameter or value not used
- R/O Parameter available for modbus in read-only mode
- R/W Parameter available for modbus in read-write mode

- S Temperature sensor
- U pump/valve managed by regulator

Accessories

System 7 - Solar system with 2 collectors and 1 storage system

The system works both on the temperature difference between the first solar collector (S1) and the low zone of storage system (S2) as well as on the temperature difference between the second solar collector (S6) and the same zone (S2) to maintain the storage temperature set in parameter no. 59 (B1LO - SETPOINT BOILER1 LOW).

If the difference S1-S2 is greater than or equal to the value set in parameter no.8 (ON12), the pump connected to output U1 is activated. The pump (U1) remains on until the temperature difference between S1 and S2 reaches the value set in parameter no.9 (OF12).

If the difference S6-S2 is greater than or equal to the value set in parameter no.14 (ON62), the pump connected to output U2 is activated. The pump (U2) remains on until the temperature difference between S6 and S2 reaches the value set in parameter no.15 (OF62).

NOTE: as second pump (U2), it is recommended to use a pump with PWM.

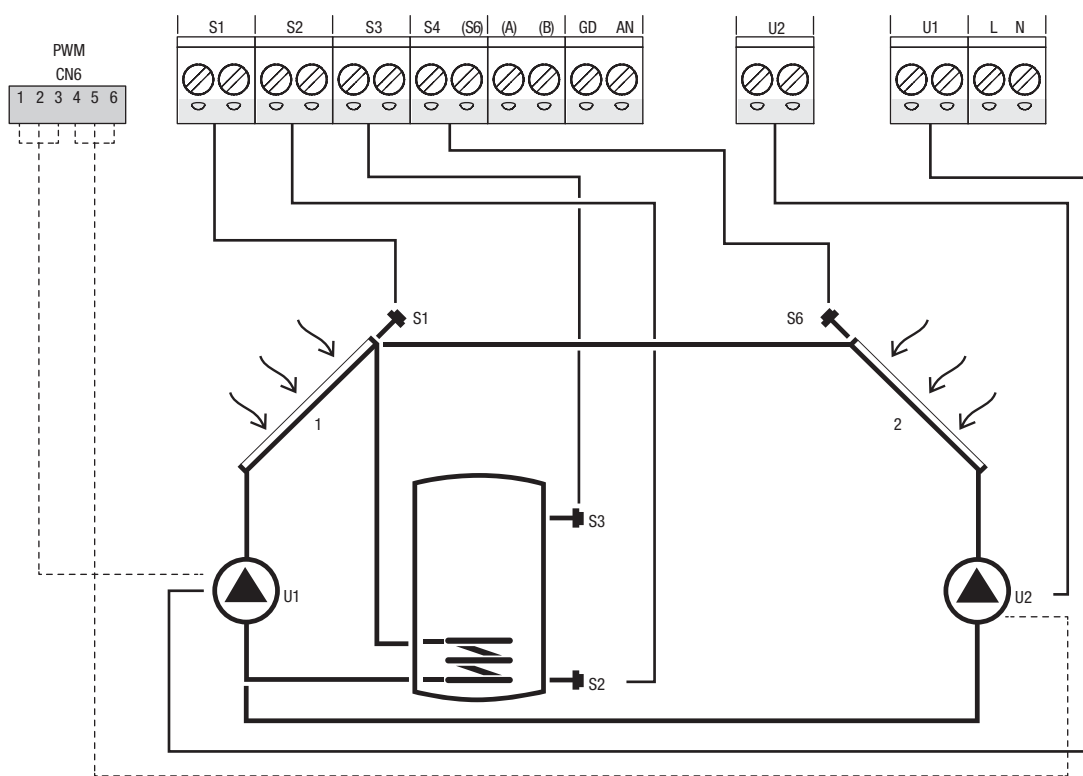

- SET Parameter can be changed
- / Parameter or value not used
- R/O Parameter available for modbus in read-only mode
- R/W Parameter available for modbus in read-write mode

- S Temperature sensor
- U pump/valve managed by regulator

**Accessories**

**System 8 - Solar system with supplementary heating through pump acting on solid fuel generator**

The system works on the temperature difference between solar collector (S1) and the low zone of the storage system (S2) to maintain the temperature set in parameter no. 59 (B1LO - SETPOINT BOILER1 LOW). It manages a supplementary system (2), for example a solid fuel generator, by working on the temperature difference between said system (S4) and the high zone of storage system (S3) to maintain the temperature set in parameter no. 56 (B1HI - SETPOINT BOILER1 HIGH).

If the difference S1-S2 is greater than or equal to the value set in parameter no.8 (ON12), the pump connected to output U1 is activated.

The pump (U1) remains on until the temperature difference between S1 and S2 reaches the value set in parameter no.9 (OF12).

If the difference S4-S3 is greater than or equal to the value set in parameter no. 24 (ON43) and the temperature of solid fuel generator (S4) is greater than the value set in parameter no. 160 (T1ON), the pump connected to output U2 is activated.

The pump (U2) remains active until the difference S4-S3 reaches the value set in parameter no. 24 (OF43) or if the temperature of solid fuel generator (S4) reaches the value set in parameter no. 163 (T1OF).

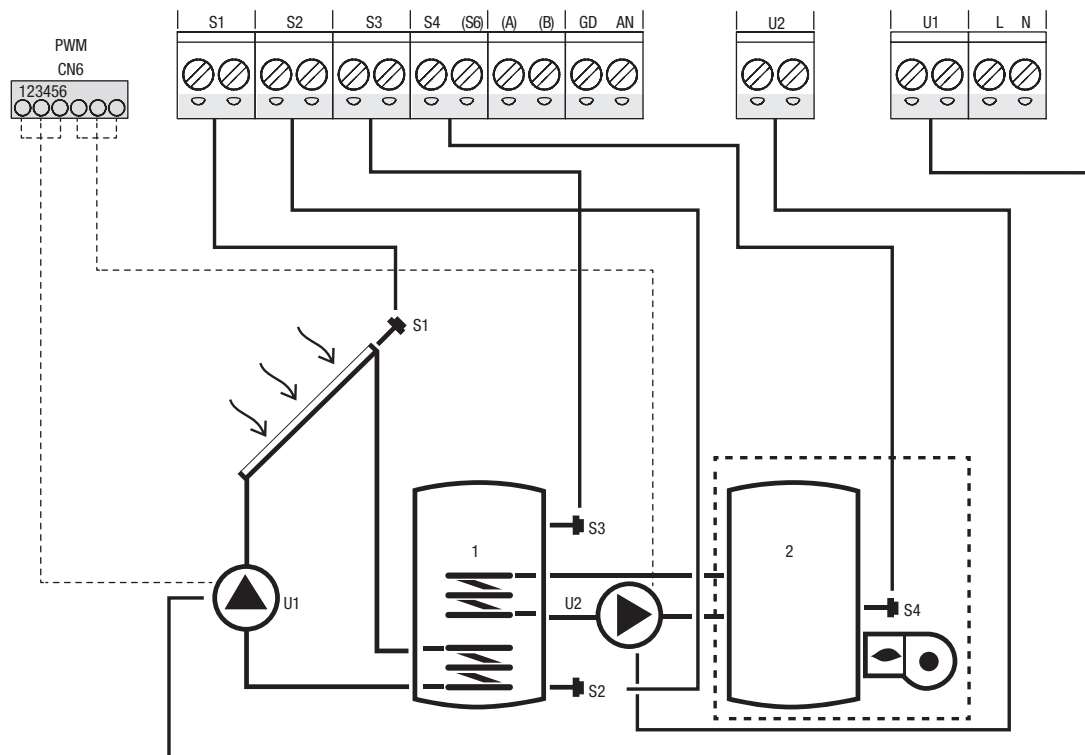

- SET Parameter can be changed
- / Parameter or value not used
- R/O Parameter available for modbus in read-only mode
- R/W Parameter available for modbus in read-write mode

- S Temperature sensor
- U pump/valve managed by regulator
- Integration system

Accessories

System 9 - Solar system with system for raising the temperature in the return flow of the heating circuit

The system works on the temperature difference between solar collector (S1) and the low zone of the storage system (S2) to maintain the storage temperature set in parameter no. 59 (B1LO - SETPOINT BOILER1 LOW). It also checks the temperature difference between the high zone of storage system (S3) and the return circuit of heating system (S6) to integrate such system in case the storage system is sufficiently heated.

The additional raising system is used for the return circuit of the heating system.

If the difference S1-S2 is greater than or equal to the value set in parameter no.8 (ON12), the pump connected to output U1 is activated.

The pump (U1) remains on until the temperature difference between S1 and S2 reaches the value set in parameter no.9 (OF12).

If the difference S3-S6 is greater than or equal to the value set in parameter no.18 (ON36), the solenoid valve connected to output U2 is switched.

The heating circuit is heated until the difference S3-S6 reaches the value set in parameter no.19 (OF36).

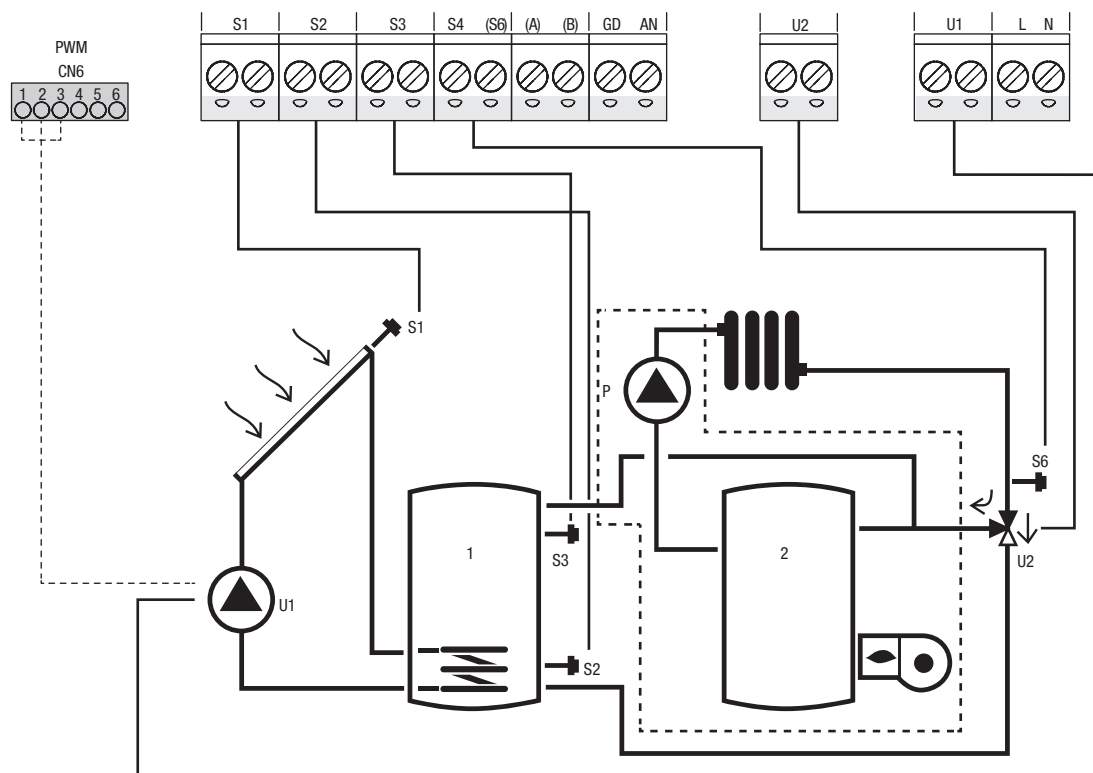

- SET Parameter can be changed
- / Parameter or value not used
- R/O Parameter available for modbus in read-only mode
- R/W Parameter available for modbus in read-write mode

- S Temperature sensor
- U pump/valve managed by regulator
- P Pump
- Heat generator

# Boilers and specific systems for solar systems

(for further information see product data sheet)

## Tower Green he S

**floor-standing condensing boiler combined with solar cylinder modulation 1:10**

**system circulation pumps: low consumption self-modulating type (EEI < 0.23)**

**possibility to control up to 3 heating zones**

**class 5 NO<sub>x</sub> emissions according to European Standard UNI EN 483**

**patented condensing heat exchanger (Patent Pending)**

**preset for connection to solar collectors.**

**interface with large display for clearer parameter setting**

**solar circuit pump as standard**

**solar circuit flow regulator as standard**

**solar circuit expansion vessel as standard**

**mixing valve as standard**

**200-litre storage tank cylinder with double coil (5-year warranty)**

**8-litre DHW expansion vessel as standard**

**thermoregulation with external sensor as standard**



The Tower Green condensing boiler is a high-efficiency, low-temperature, hot water production appliance for heating systems and for domestic hot water, through a double-coil solar cylinder with a capacity of 200 litres, fitted as standard with a hydraulic return unit for use with solar collectors.

It includes a compact monobloc aluminium heat exchanger with low water content and low pressure drop, and a premixed micro-flame burner managed by an electronic control panel, all placed inside a solid self-supporting housing. The appliance has a sealed combustion chamber and, depending on the flue gas outlet accessory, is classified in categories B23P; B53P; C13, C13x; C23; C33, C33x; C43, C43x C53, C53x; C63, C63x; C83, C83x; C93, C93x. The fan, constantly controlled by the electronic board, is used to eject the combustion products and to suck in the combustion air from outside.

The characteristics of the generator body and the burner allow for excellent performance from a heat technology standpoint.

The combustion chamber and the development of the heat exchange surfaces are designed to keep the burner surface temperature low, in order to limit emissions, achieve high combustion yields and improve reliability during ignition. The Tower Green boiler is completed with safety valves, vent valves, expansion vessels, drain valves, system loading tap and circulation pumps for the heating system, for the cylinder and for the solar circuit.

The management of several heating zones, at high and low temperature, can be achieved with the help of specific accessories in the catalogue.

## Boilers and specific systems for solar systems

# Tower Green HE S Hybrid

**floor-standing condensing boiler combined with solar cylinder modulation 1:10**

**system circulation pumps: low consumption self-modulating type (EEI < 0.23)**

**possibility to control up to 3 heating zones**

**class 5 NOx emissions according to European Standard UNI EN 483**

**patented condensing heat exchanger (Patent Pending)**

**preset for connection to solar collectors.**

**interface with large display for clearer parameter setting**

**solar circuit pump**

**solar circuit flow regulator**

**18-litre solar circuit expansion vessel**

**DHW mixing valve**

**200-litre storage tank cylinder with double coil (5-year warranty)**

**8-litre DHW expansion vessel**

**thermoregulation with external sensor as standard**

The Tower Green HE S Hybrid condensing boiler is a high-efficiency, hot water production appliance for heating systems and for domestic hot water, through a double-coil solar cylinder with a capacity of 200 litres, fitted as standard with a hydraulic return unit for use with solar collectors. The Tower Green HE S Hybrid boiler is ready for external connection to a Hydronic Unit heat pump for heating and chilling integration of the thermal system. It includes a compact monobloc aluminium heat exchanger with low water content and low pressure drop, and a premixed micro-flame burner managed by an electronic control panel, all placed inside a solid self-supporting housing. The appliance has a sealed combustion chamber and, depending on the flue gas outlet accessory, is classified in categories B23P; B53P; C13, C13x; C33, C33x; C43, C43x C53, C53x; C63, C63x; C83, C83x; C93, C93x. The fan, constantly controlled by the electronic board, is used to eject the combustion products and to suck in the combustion air from outside.

The characteristics of the generator body and the burner allow for excellent performance from a heat technology standpoint.

The combustion chamber and the development of the heat exchange surfaces are designed to keep the burner surface temperature low, in order to limit emissions, achieve high combustion yields and improve reliability during ignition. The Tower Green HE S Hybrid boiler is completed with safety valves, vent valves, expansion vessels, drain valves, filler tap and circulation pumps for the heating system, for the cylinder and for the solar circuit.

The management of several heating and chilling zones, direct or mixed, can be achieved with the help of specific accessories in the catalogue.



## Boilers and specific systems for solar systems

### Solar Box LE

Built-in integrated system for the production of domestic hot water and heating equipped with low-energy circulation pumps (EEI ≤ 0.23).

#### Solution with combined condensing boiler

System supplied as a kit, consisting of:

- **Recessed "Solar Box"**: outdoor recessed box designed to accommodate the complete system except for the solar collector.
- **"Solar Box" module**: to be chosen according to the type of heating system.
- **MS "Solar Box" cylinder**: stainless steel, single coil, 150-litre capacity.
- **C.S.I. "Solar Box" ramps**: connection pipes between module and C.S.I. boiler, gas cock.
- **"Solar Box" fittings**: fittings and cocks for connection to the template of the built-in cabinet.

**Applicable boilers**: all combined outdoor condensing boilers (see price list).

#### Solution with heating-only condensing boiler

System supplied as a kit, consisting of:

- **Recessed "Solar Box"**: outdoor recessed box designed to accommodate the complete system except for the solar collector.
- **"Solar Box" module**: to be chosen according to the type of heating system.
- **DS "Solar Box" cylinder**: stainless steel, double coil, 150-litre capacity.
- **R.S.I. "Solar Box" ramps**: connection pipes between module and R.S.I. boiler, gas cock.
- **"Solar Box" fittings**: fittings and cocks for connection to the template of the built-in cabinet.

**Applicable boilers**: all heating-only condensing boilers for outdoor use (see price list).



## Boilers and specific systems for solar systems

# Hybrid Box



### Recessed unit

Hybrid Box is a premixed condensing thermal unit for flush-mounted installation for heating, summer air conditioning and domestic hot water production with solar integration. It is available with powers from 25 to 35 kW in the version with instant combined boiler and bivalent cylinder with double coil and makes use of the contribution of the heat pump (external unit) both for the production of domestic hot water and for the needs of the system.

### Outdoor unit

The outdoor unit is Beretta's proposal for heating and chilling with a high-efficiency heat pump with the possibility of producing domestic hot water. The unit is equipped with a DC-Inverter control with PAM and PWM modulation, which allows a continuous modulation for the compressor from 30% up to 120%, ensuring high energy standards at all times. For the 6 and 8 kW models, the compressor is of the TWIN Rotary type. The operating range of the unit in winter reaches external temperatures down to  $-20\text{ }^{\circ}\text{C}$ , with hot water up to  $+60\text{ }^{\circ}\text{C}$ ; in summer operation the maximum external temperature is  $+46\text{ }^{\circ}\text{C}$  with a maximum chilled water temperature of  $+18\text{ }^{\circ}\text{C}$ . The outdoor unit is therefore the ideal solution for any type of residential application for heating and cooling with underfloor installations and/or fan coils. The unit is monobloc, so all components are housed inside to facilitate and speed up installation operations. Available in three models: 4 - 6 - 8 kW.

# Examples of solar thermal systems

Compact hybrid system with solar thermal, heat pump (hot/cold) and combined boiler and integrated with the heating system and domestic hot water cylinder - HYBRID BOX

- 1 Hydronic heat pump
- 2 HYBRID BOX with condensing boiler and two system zones
- 3 Flat solar collectors
- 4 Electrical panel with remote control and 230 Vac switches and summer/winter switch
- 5 External sensor positioned North-North/West
- 6 Distribution manifolds with electrothermal heads
- 7 Ambient chronothermostats
- 8 Hydronic split terminals
- 9 Radiant panels system
- 10 Domestic hot water users

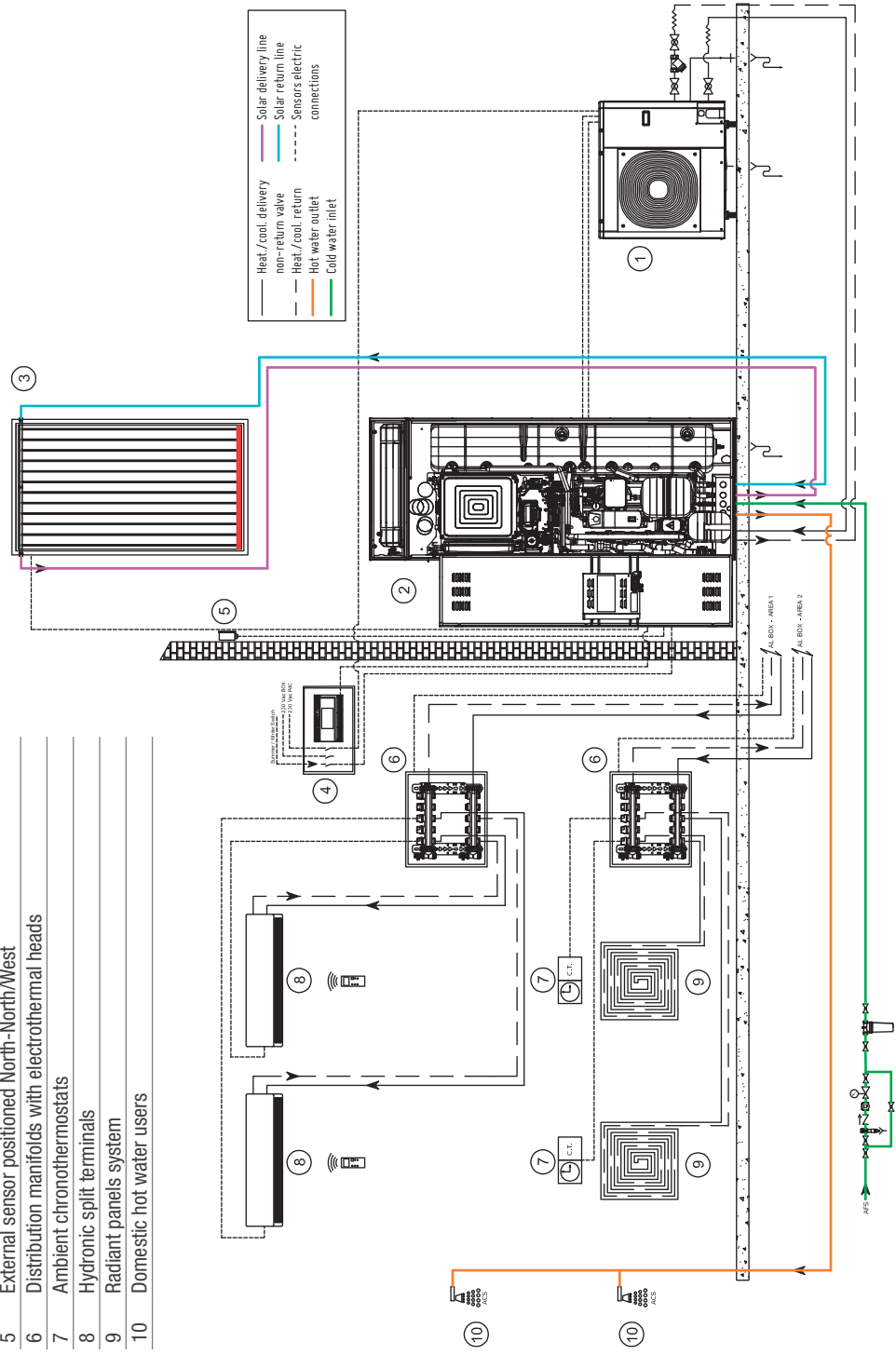

Examples of solar thermal systems

Compact hybrid system with solar thermal, heat pump (hot/cold) and combined boiler for integration for integration with the heating system and domestic hot water cylinder - HYBRID BOX

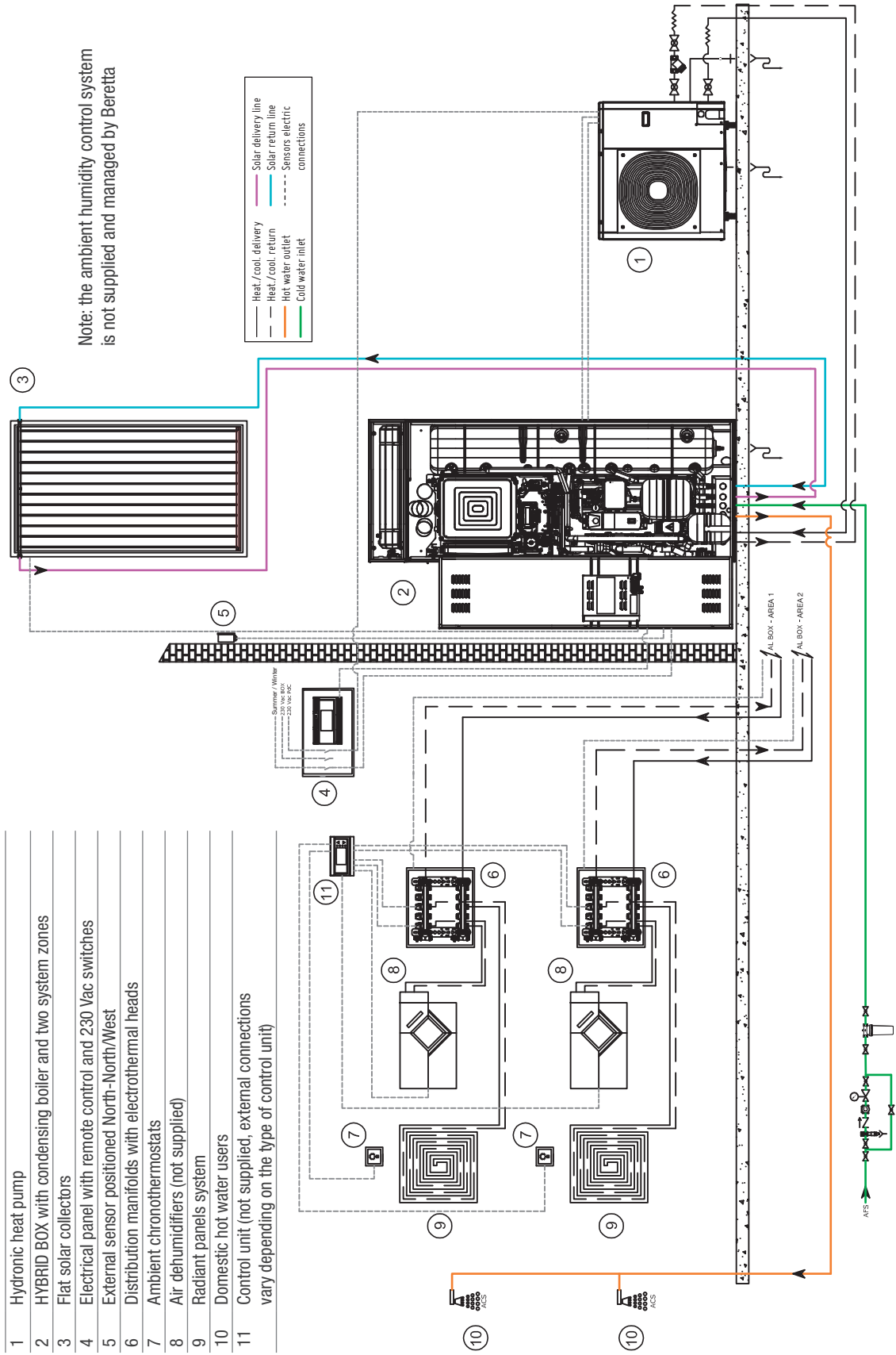

Note: the ambient humidity control system is not supplied and managed by Beretta

- 1 Hydronic heat pump
- 2 HYBRID BOX with condensing boiler and two system zones
- 3 Flat solar collectors
- 4 Electrical panel with remote control and 230 Vac switches
- 5 External sensor positioned North-North/West
- 6 Distribution manifolds with electrothermal heads
- 7 Ambient chronothermostats
- 8 Air dehumidifiers (not supplied)
- 9 Radiant panels system
- 10 Domestic hot water users
- 11 Control unit (not supplied, external connections vary depending on the type of control unit)

Examples of solar thermal systems

Heating system with heat pump and SOLAR BOX - Integration of domestic hot water with solar thermal system

- 1 Hydronic heat pump
- 2 SOLAR BOX with condensing boiler and one direct zone
- 3 Flat solar collectors
- 4 Electrical panel with remote control for heat pump, 230 Vac switches and SUMMER/WINTER switch
- 5 External sensor positioned North-North/West
- 6 Distribution manifolds with electrothermal heads
- 7 Ambient chronothermostats
- 8 Radiant panels system
- 9 Domestic hot water users
- 10 Connect - two zones
- 11 Relay 230 VAC
- 12 Hydraulic flywheel for heat pump

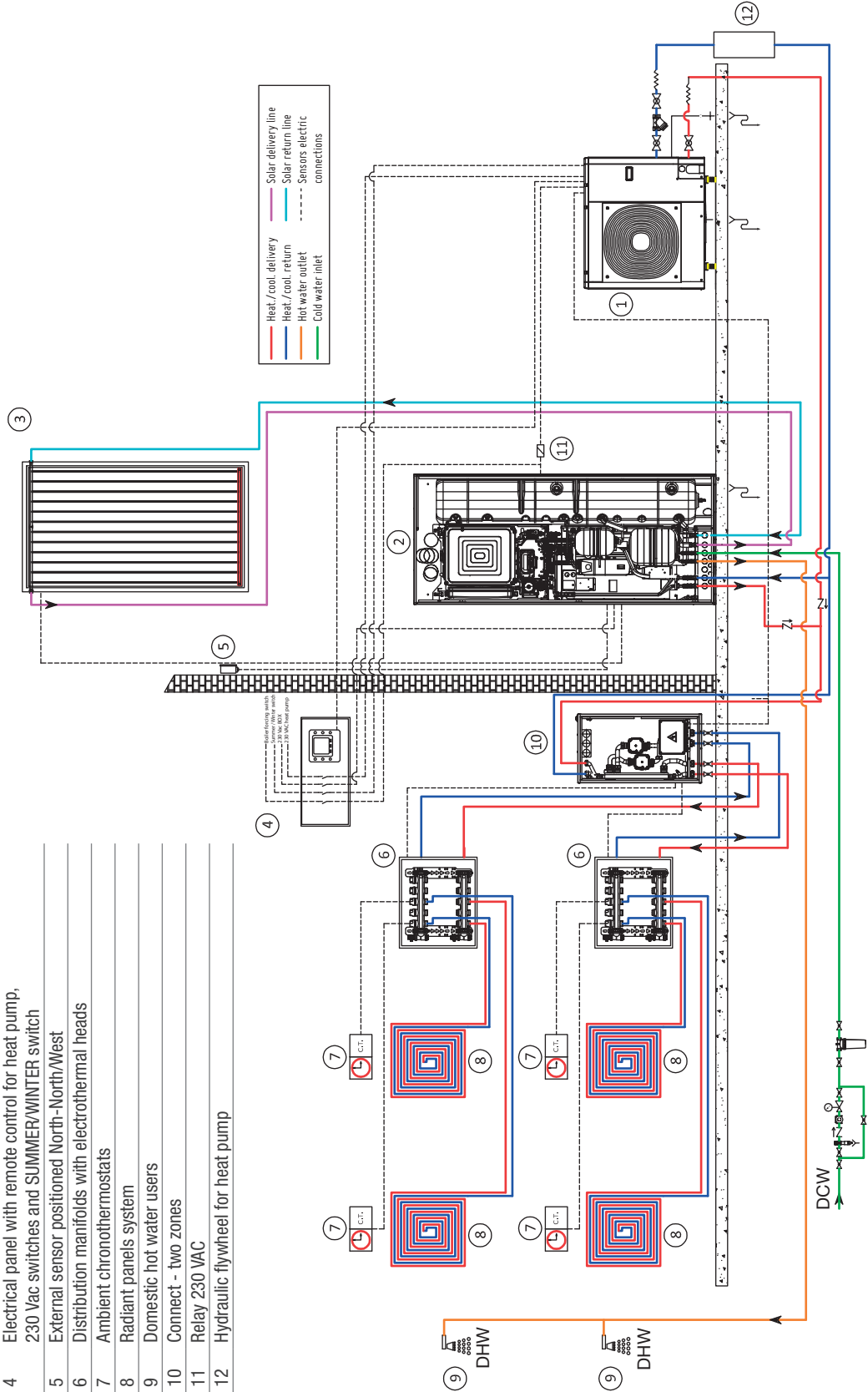

### Examples of solar thermal systems

#### DHW integration system with cylinder in heat pump (HP 260 S) and solar thermal system

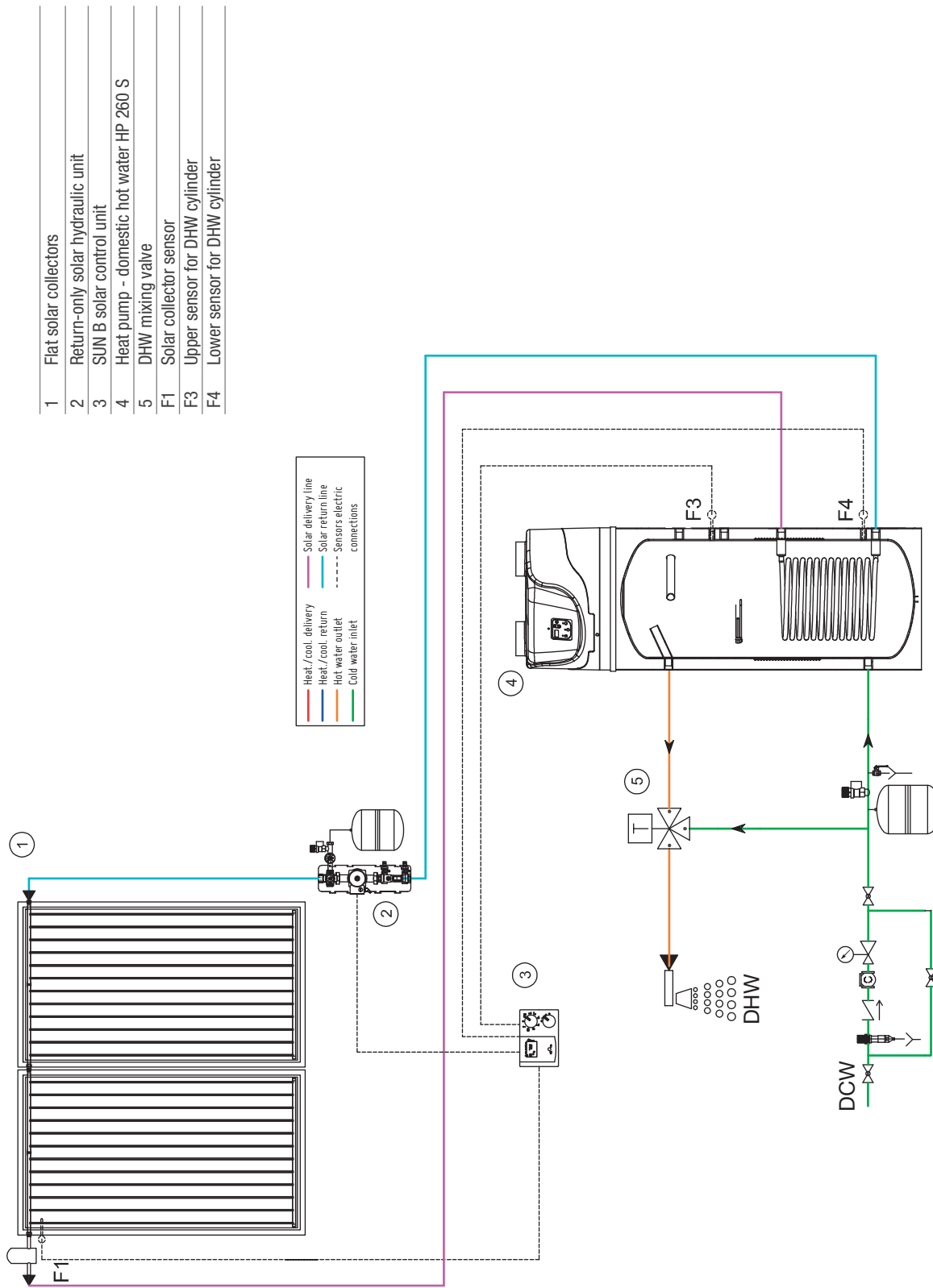

Examples of solar thermal systems

DHW integration system with cylinder in heat pump (HP 260 SC) and solar thermal system - Heating-only boiler for heating system integration and DHW cylinder

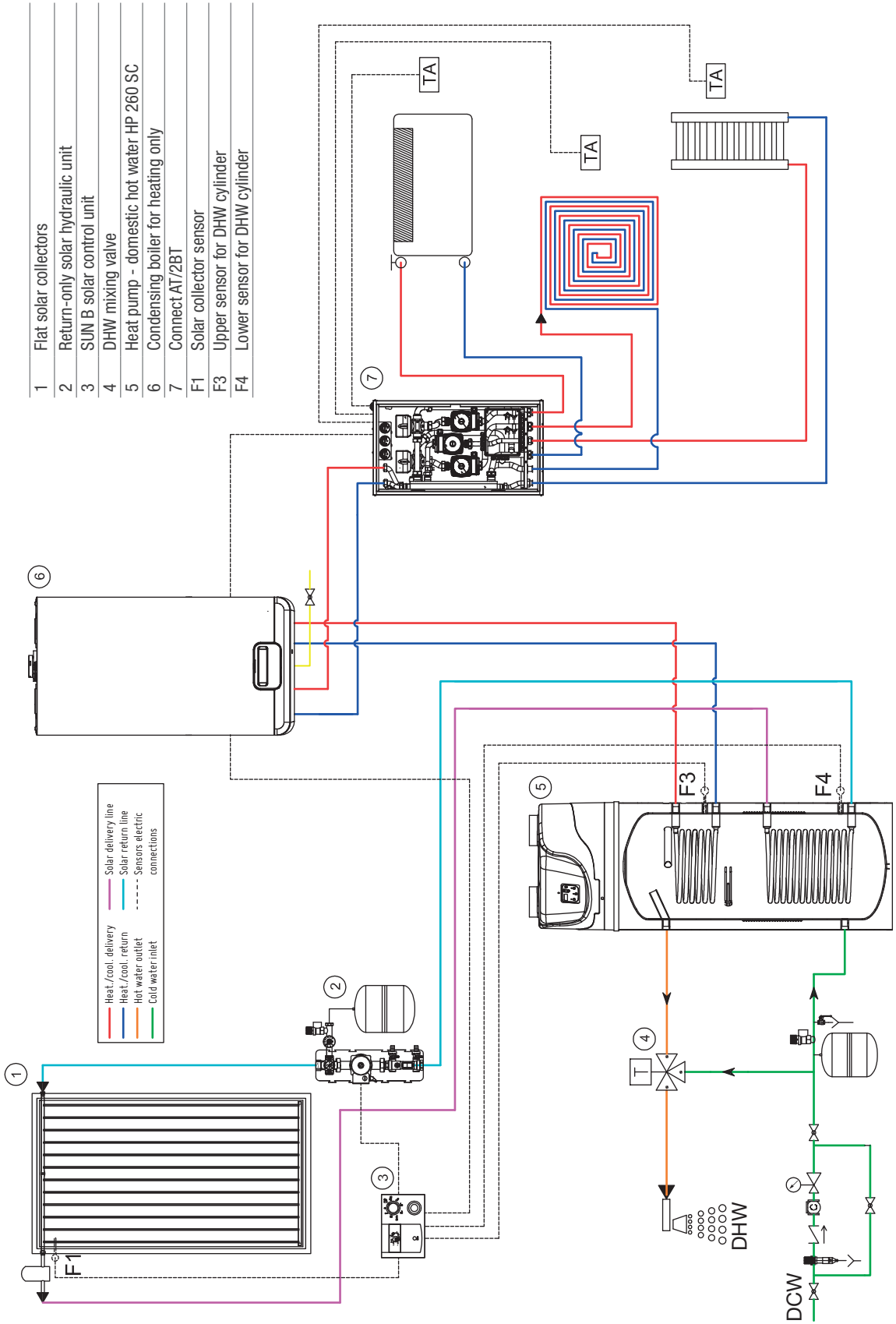

Examples of solar thermal systems

DHW integration system with cylinder in heat pump (HP 260 SC) and solar thermal system - Combined boiler for heating system integration, preheating function at domestic hot water withdrawal - Pellet stove for heating system integration and DHW cylinder

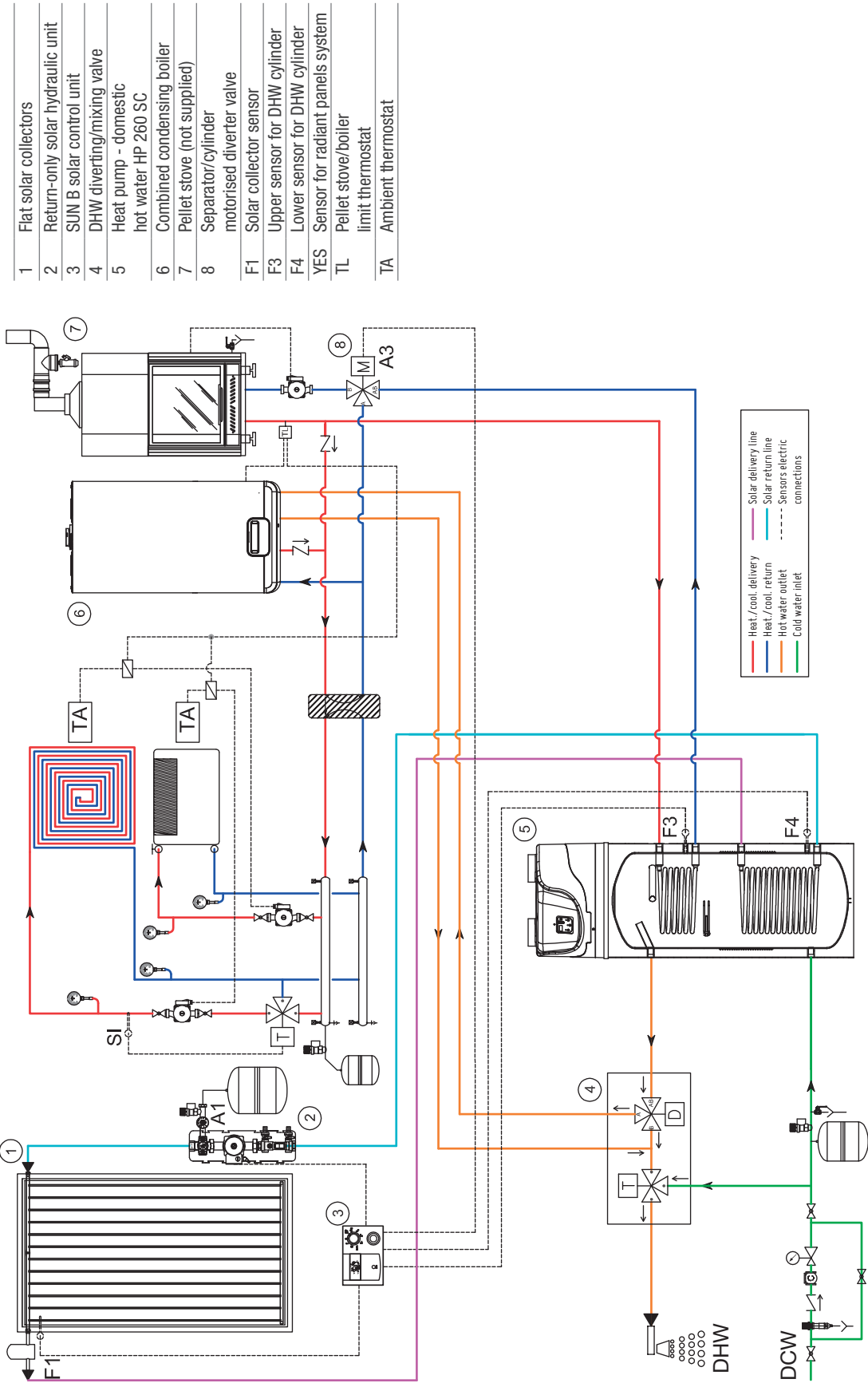

- 1 Flat solar collectors
- 2 Return-only solar hydraulic unit
- 3 SUN B solar control unit
- 4 DHW diverting/mixing valve
- 5 Heat pump - domestic hot water HP 260 SC
- 6 Combined condensing boiler
- 7 Pellet stove (not supplied)
- 8 Separator/cylinder motorised diverter valve
- F1 Solar collector sensor
- F3 Upper sensor for DHW cylinder
- F4 Lower sensor for DHW cylinder
- YES Sensor for radiant panels system
- TL Pellet stove/boiler limit thermostat
- TA Ambient thermostat

Examples of solar thermal systems

Hybrid heat pump system and combined boiler for integration with the heating system and the double-coil solar cylinder for preheating DHW production

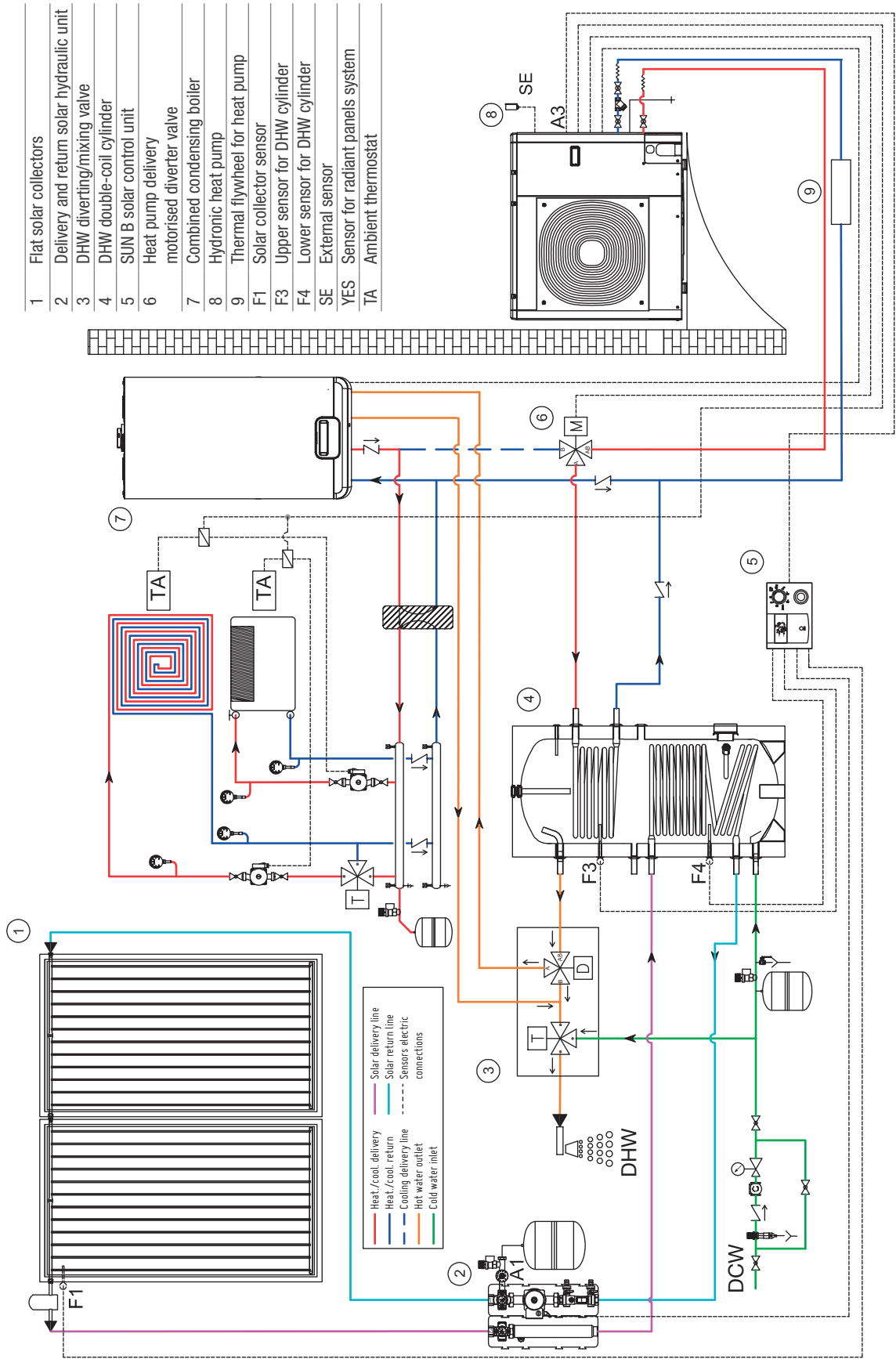

Examples of solar thermal systems

Hybrid system with heat pump and heating-only boiler for integration with the heating system and the double-coil solar cylinder for DHW production

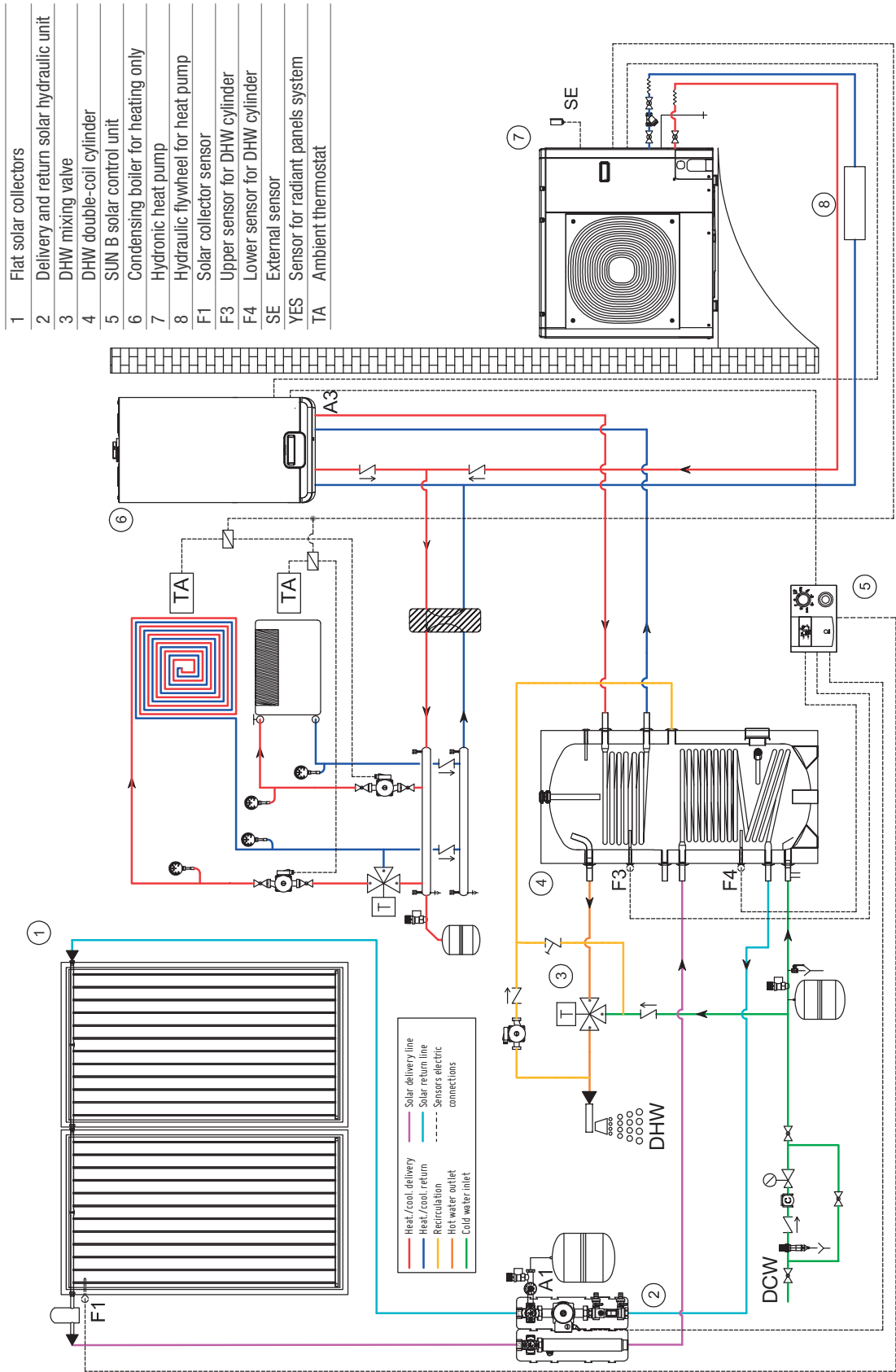

- 1 Flat solar collectors
- 2 Delivery and return solar hydraulic unit
- 3 DHW mixing valve
- 4 DHW double-coil cylinder
- 5 SUN B solar control unit
- 6 Condensing boiler for heating only
- 7 Hydronic heat pump
- 8 Hydraulic flywheel for heat pump
- F1 Solar collector sensor
- F3 Upper sensor for DHW cylinder
- F4 Lower sensor for DHW cylinder
- SE External sensor
- YES Sensor for radiant panels system
- TA Ambient thermostat

Examples of solar thermal systems

Heat pump system for integration with the heating system and DHW production with cylinder in heat pump (HP 260 S) integrated with solar thermal system

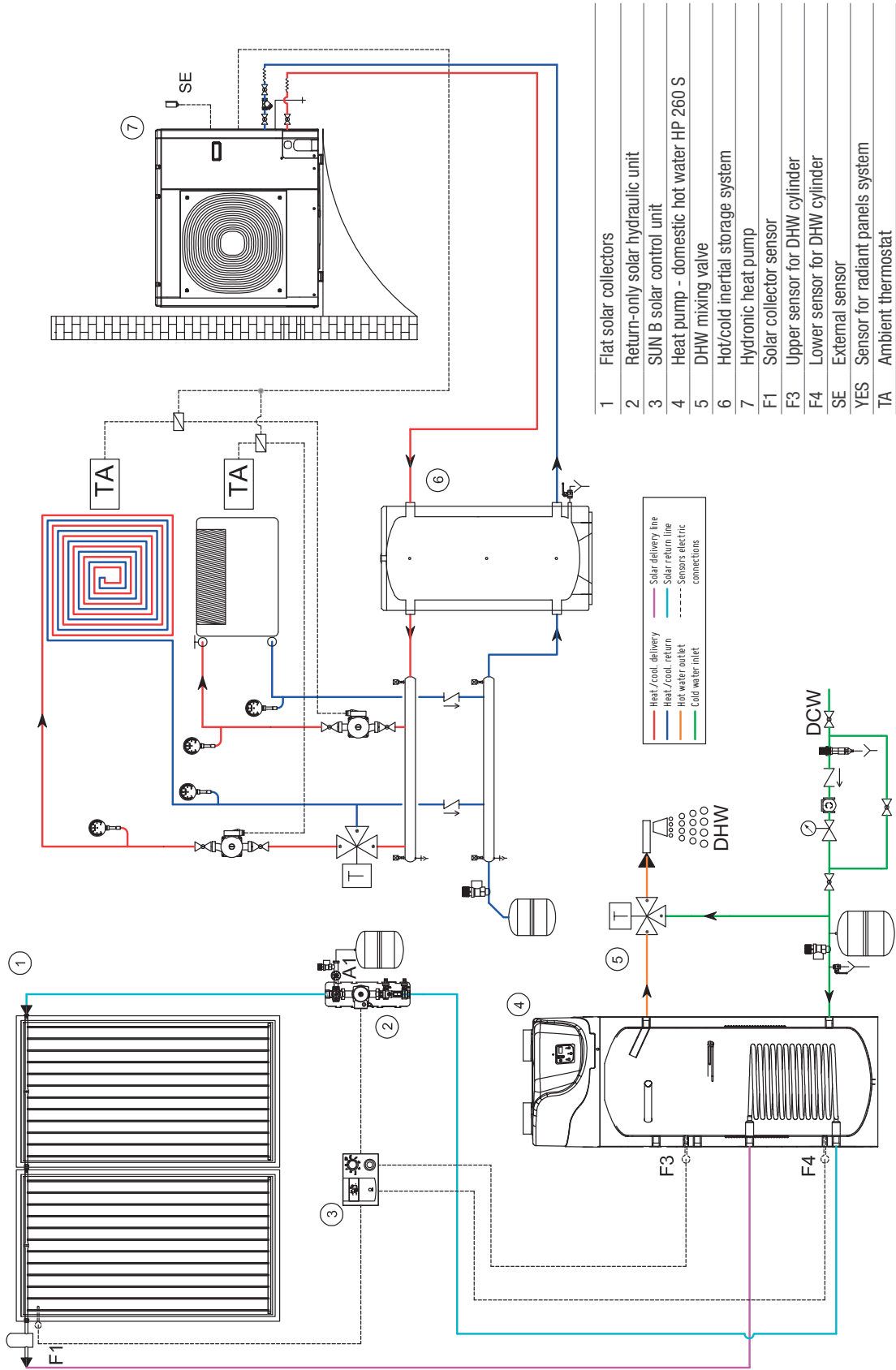

Examples of solar thermal systems

Centralised hybrid system with heat pump and boiler for integration with the heating system and DHW production through inertial single-coil storage tank (solar thermal system, heat pump and boiler)

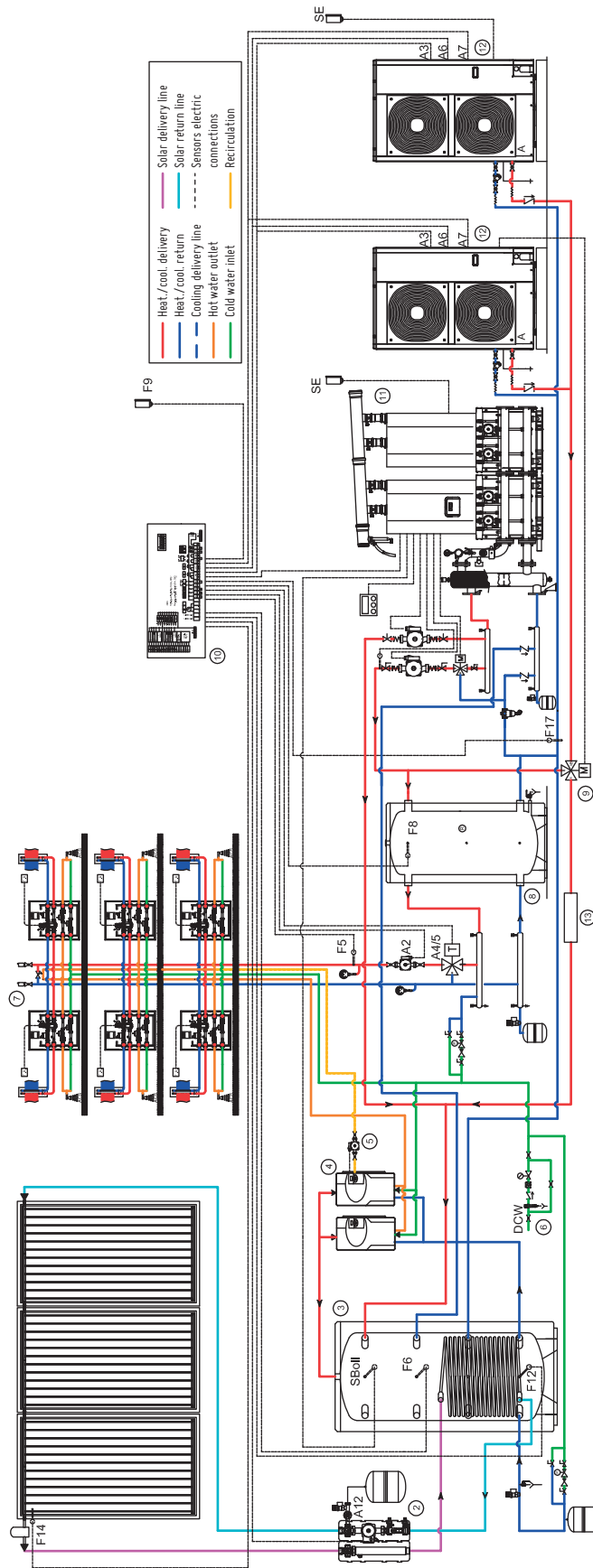

1	Flat solar collectors
2	Delivery and return solar hydraulic unit
3	Inertial single-coil storage
4	Modules for domestic hot water production in cascade; DHW with low consumption
5	Circulating pump for DHW recirculation
6	DCW inlet unit
7	Direct reading heat meters

8	Inertial storage (hot/cold)
9	Storage/cylinder motorised diverter valve
10	Control unit for system management CONTROL SYSTEM V4
11	Thermal module
12	Hydronic heat pumps in cascade
13	Hydraulic flywheel for heat pump
F5	Sensor for radiant panels system

F6	Upper storage sensor
F9	Central storage sensor
F9	External sensor
F12	Lower storage sensor
F11	Stove thermostat sensor
F14	Solar collector sensor
F17	Heat pump return sensor
SBoll	Cylinder sensor

### Examples of solar thermal systems

## Hybrid system with heat pump, boiler and stove for integration with the heating system and DHW production through combined triple-coil storage system

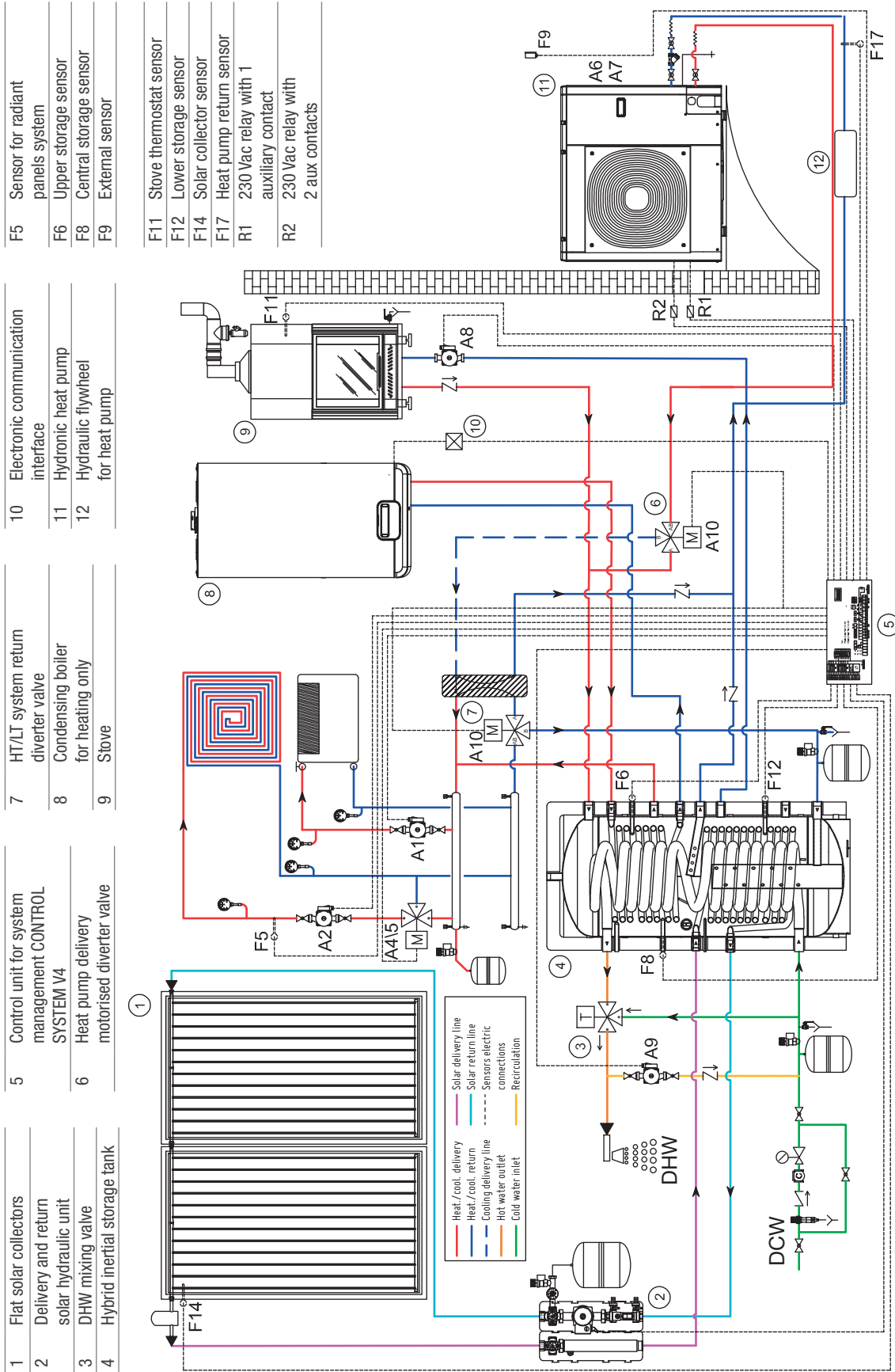

# Centralised hybrid system with heat pump and boiler for integration with the heating system and instantaneous DHW production through storage tanks and heat exchangers

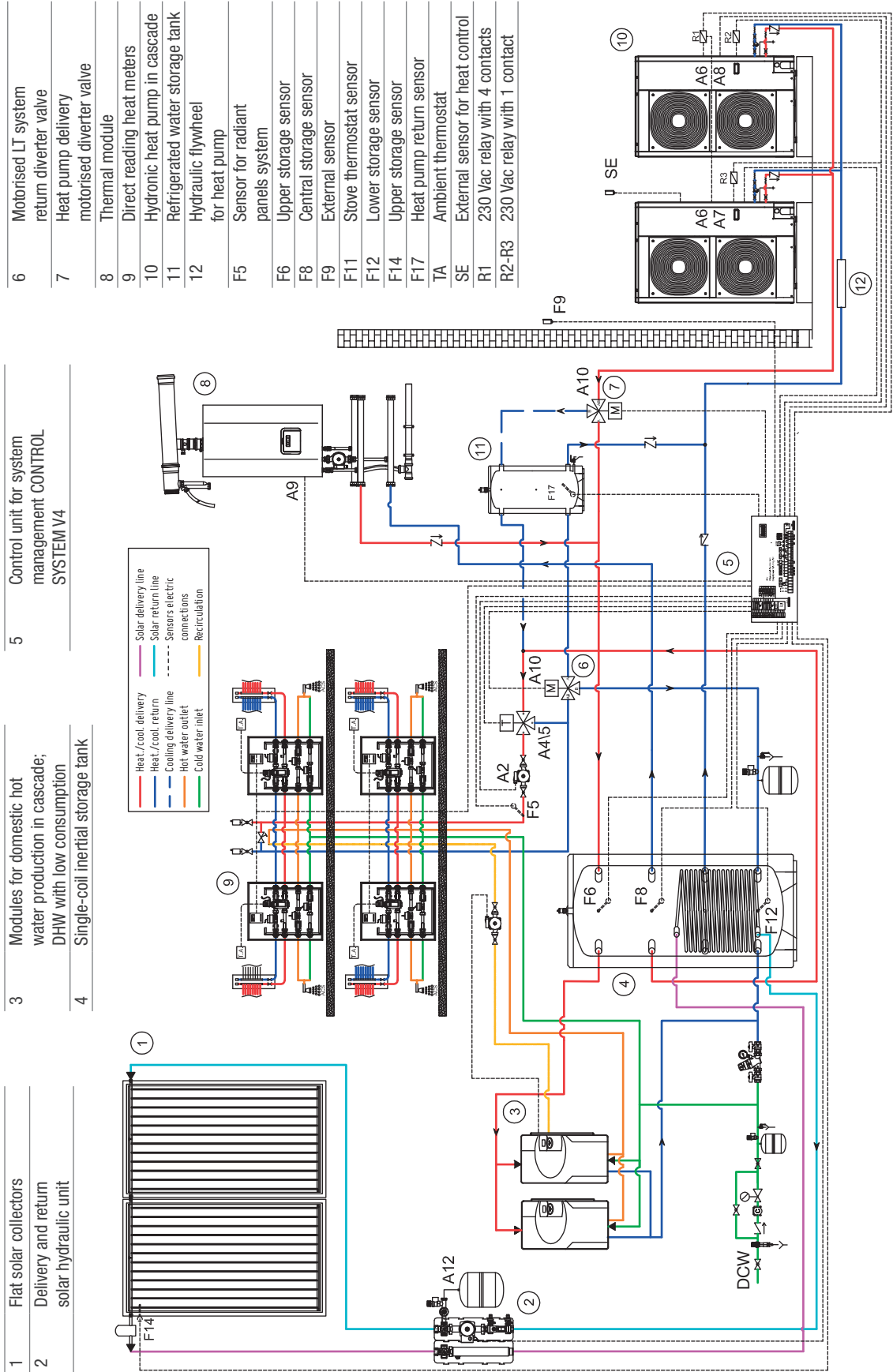

Examples of solar thermal systems

Hybrid system with heat pump and heating-only boiler for integration with the heating system and the double-coil solar cylinder for DHW production

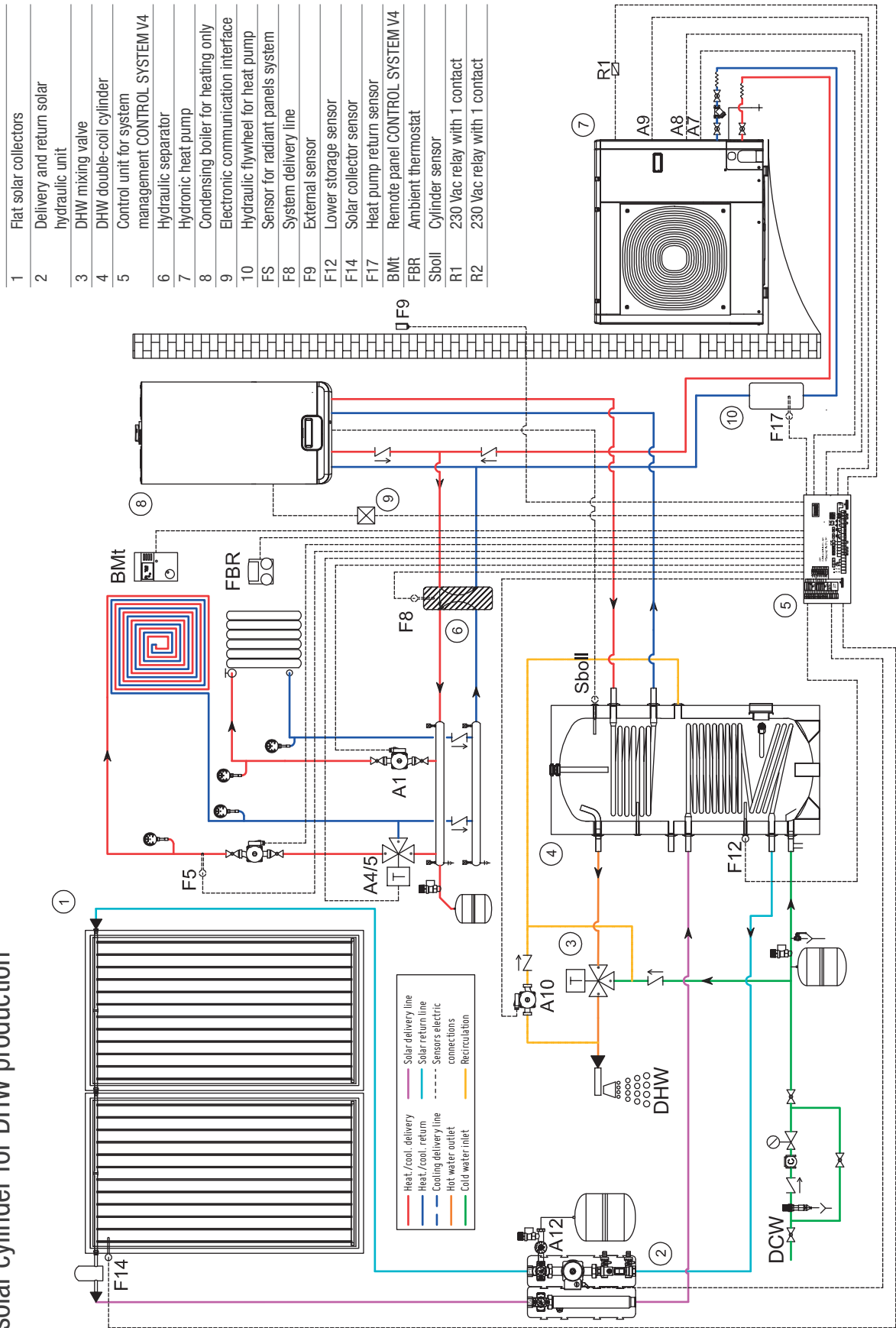

Hybrid system with heat pump (hot/cold) and combined boiler for integration with the heating system and the single-coil solar cylinder for DHW production

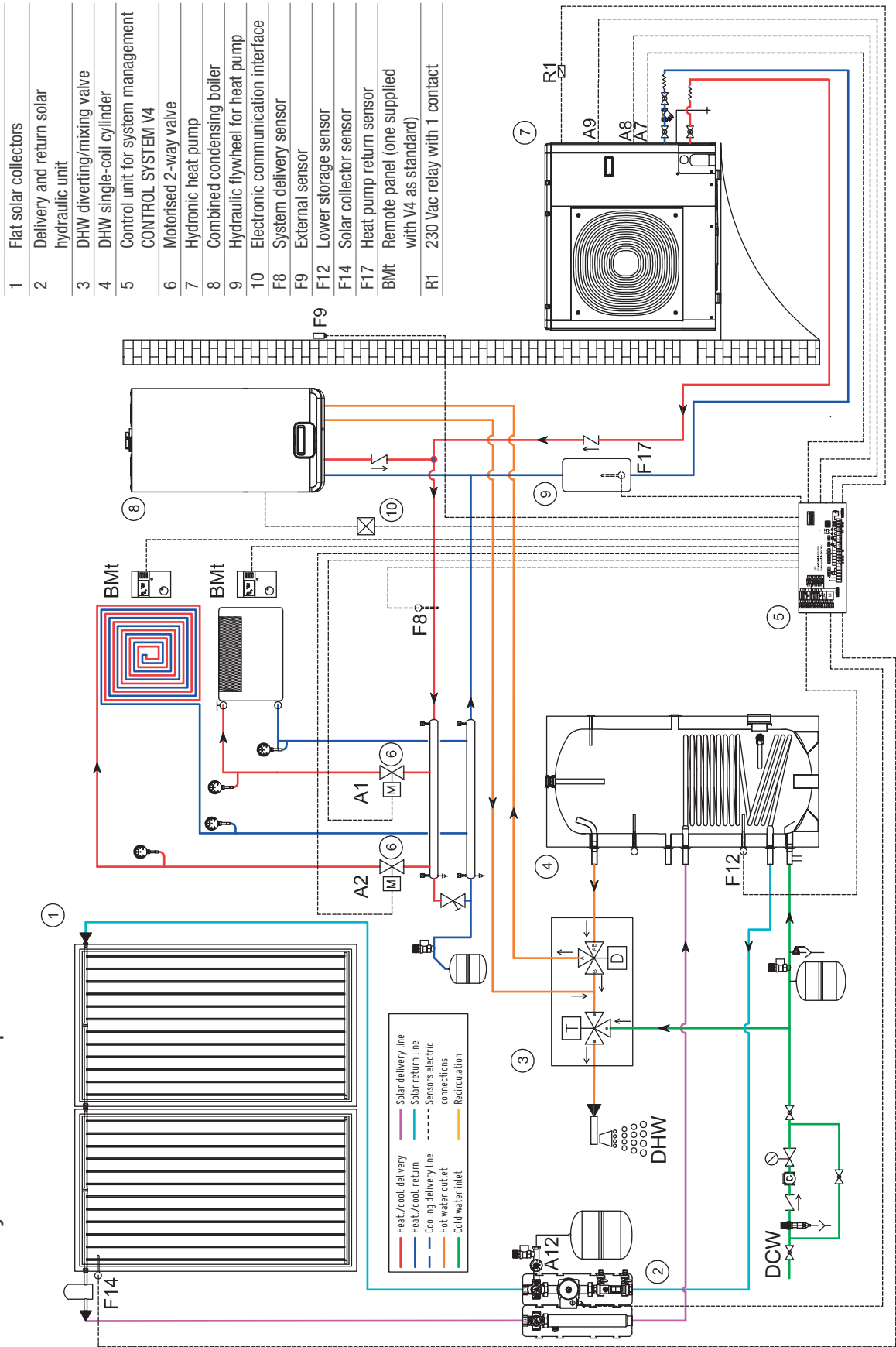

Examples of solar thermal systems

TOWER GREEN HE S floor-standing system for integration with the heating system and the double-coil solar cylinder for DHW production

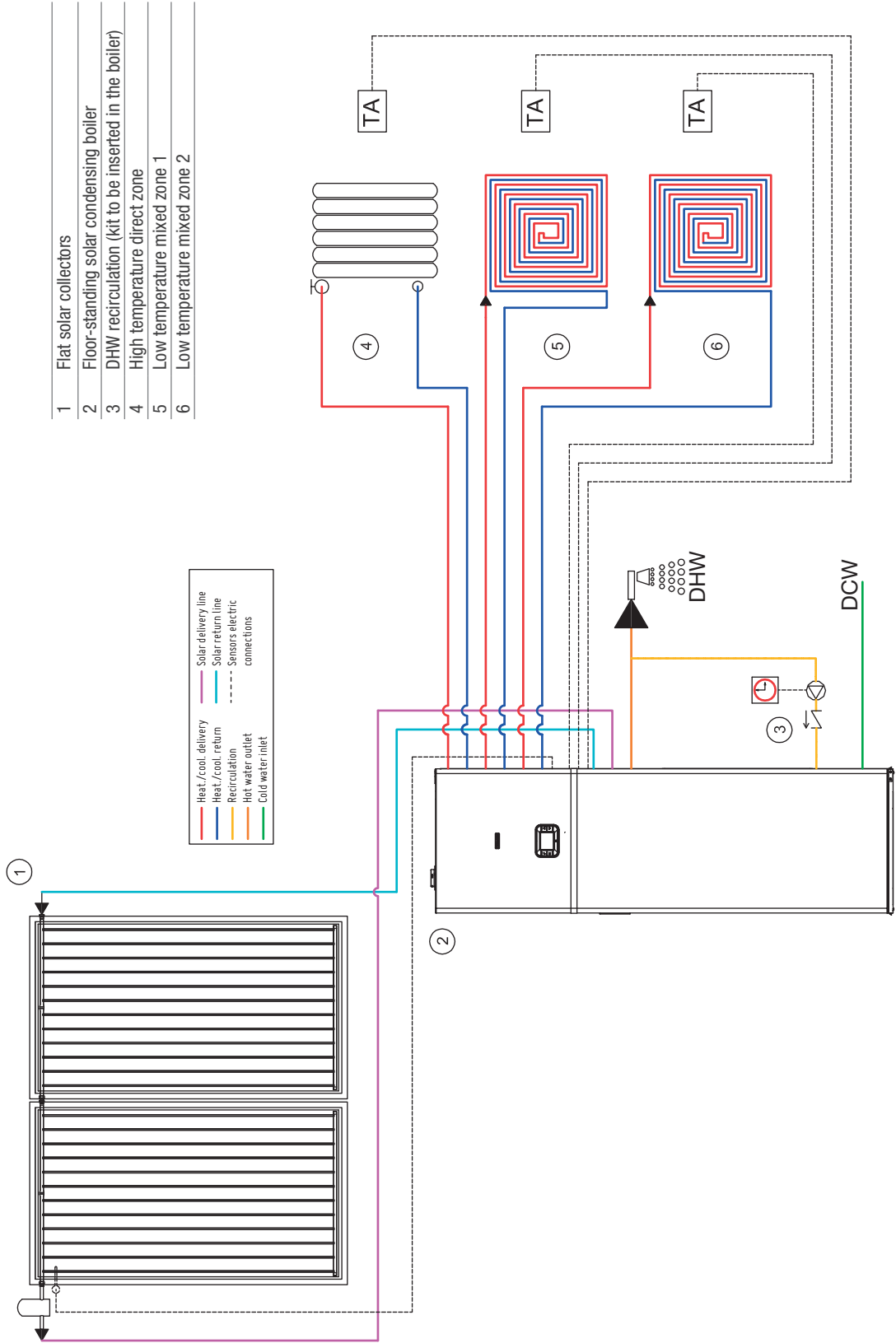

Examples of solar thermal systems

TOWER GREEN HE HYBRID S floor-standing system for integration with the heating/chilling system and the double-coil solar cylinder for DHW production

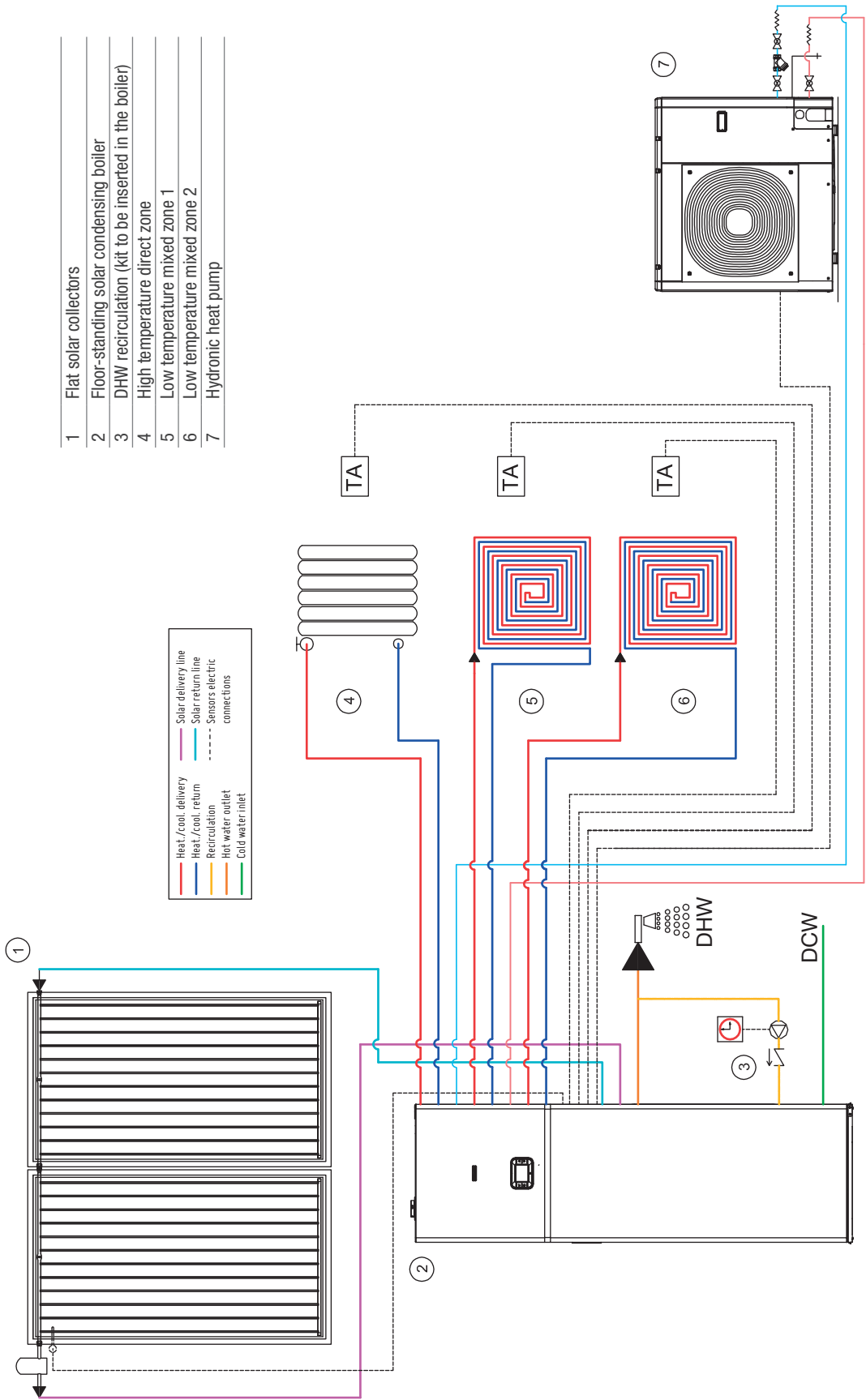

- 1 Flat solar collectors
- 2 Floor-standing solar condensing boiler
- 3 DHW recirculation (kit to be inserted in the boiler)
- 4 High temperature direct zone
- 5 Low temperature mixed zone 1
- 6 Low temperature mixed zone 2
- 7 Hydronic heat pump

Heat / cool delivery	Solar delivery line
Heat / cool return	Solar return line
Recirculation	Sensors electric connections
Hot water outlet	
Cold water inlet	

Examples of solar thermal systems

Solar thermal system for DHW integration and only-heating boiler for integration with the heating system and the double-coil cylinder

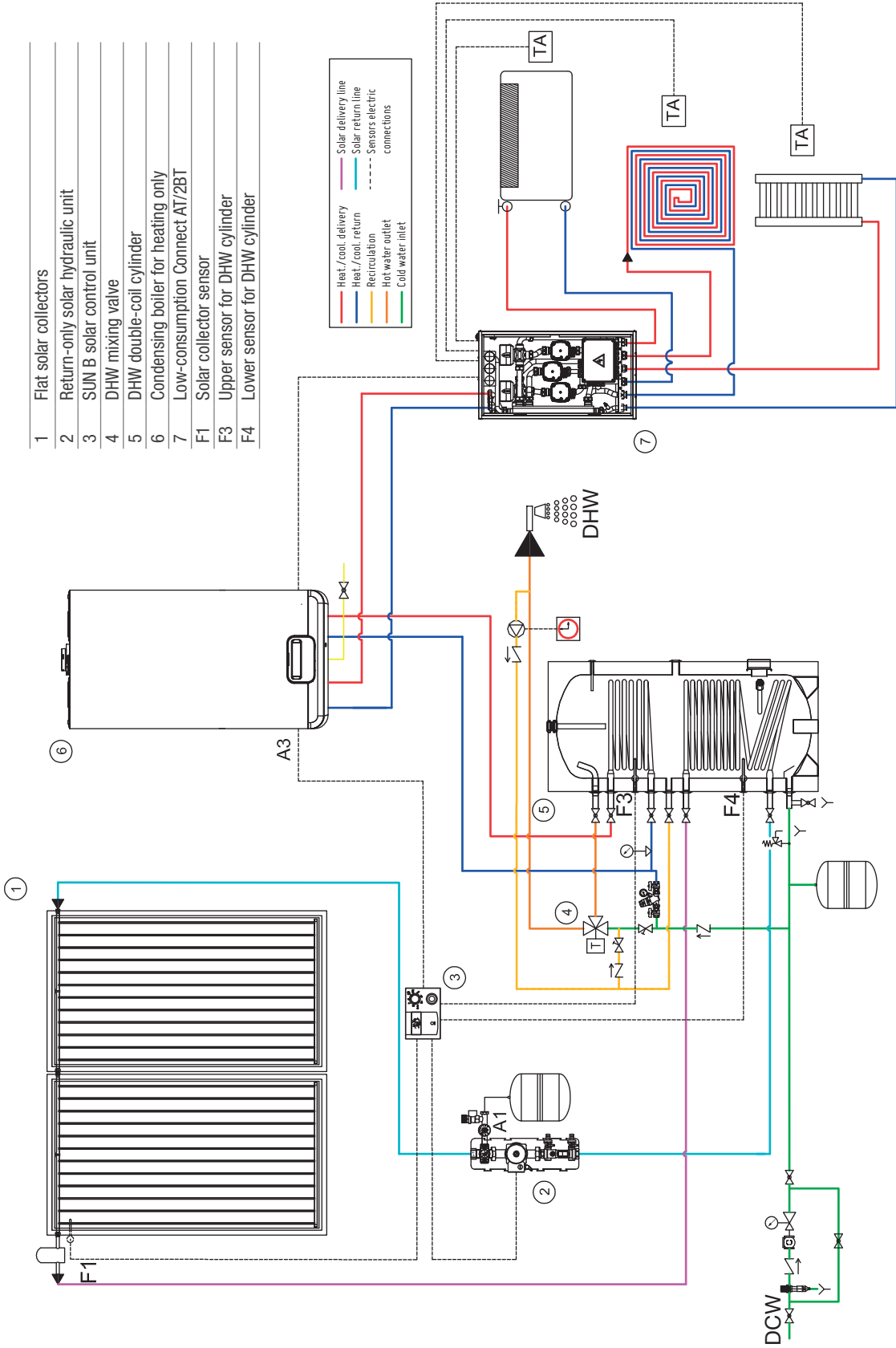

- 1 Flat solar collectors
- 2 Return-only solar hydraulic unit
- 3 SUN B solar control unit
- 4 DHW mixing valve
- 5 DHW double-coil cylinder
- 6 Condensing boiler for heating only
- 7 Low-consumption Connect AT/2BT
- F1 Solar collector sensor
- F3 Upper sensor for DHW cylinder
- F4 Lower sensor for DHW cylinder

Examples of solar thermal systems

Solar thermal system for integration with a combined storage tank and boiler for heating only

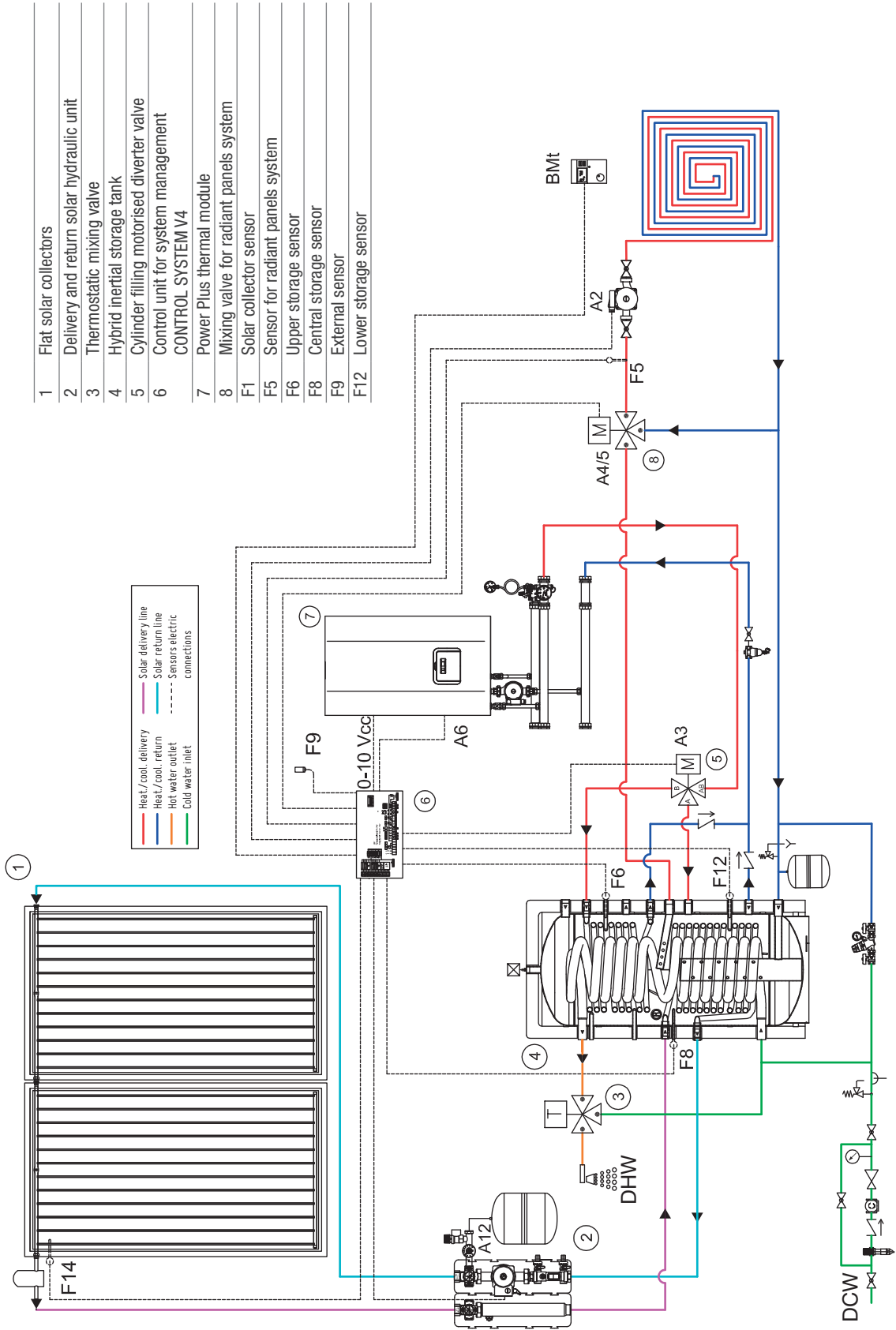

### Examples of solar thermal systems

Solar thermal system for DHW integration with preheating cylinder and second boiler cylinder

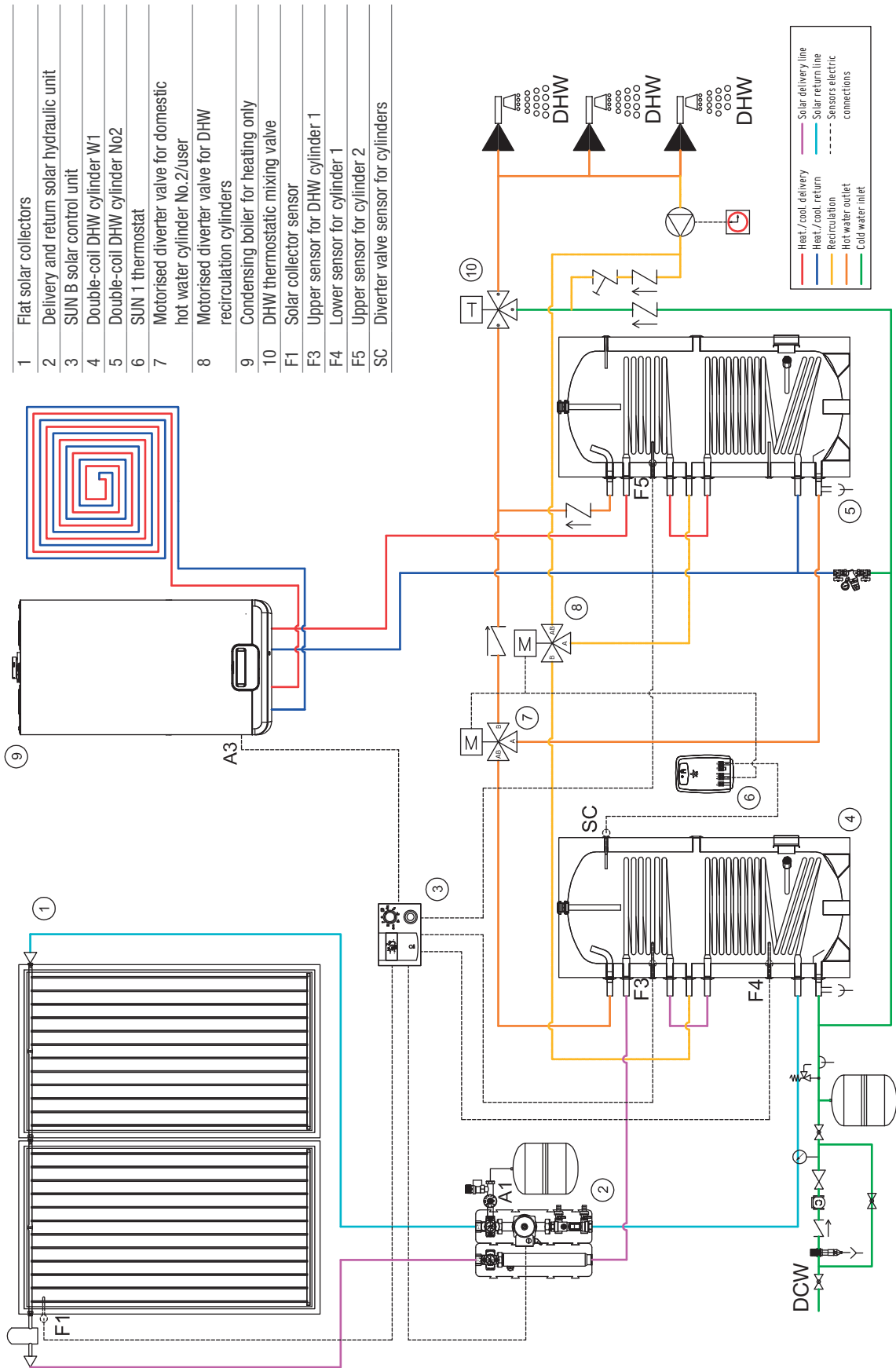

Examples of solar thermal systems

Combined solar thermal centralised system for heating and domestic hot water integration through cylinder

- 9 Thermostatic mixing valve
- 10 Thermal module
- F1 Solar collector sensor
- F2 Lower storage sensor
- F3 Upper sensor for DHW cylinder
- F4 Lower sensor for DHW cylinder
- SC Radiant panels system return sensor
- SB Upper storage sensor
- R1 230 Vac relay with 2 aux contacts

- 1 Flat solar collectors
- 2 Delivery and return solar hydraulic unit
- 3 Single-coil inertial storage system
- 4 SUN B solar control unit
- 5 DHW double-coil cylinder return diverter valve
- 6 Low temperature system return thermostat
- 7 SUN1 thermostat
- 8 Multifunction relay

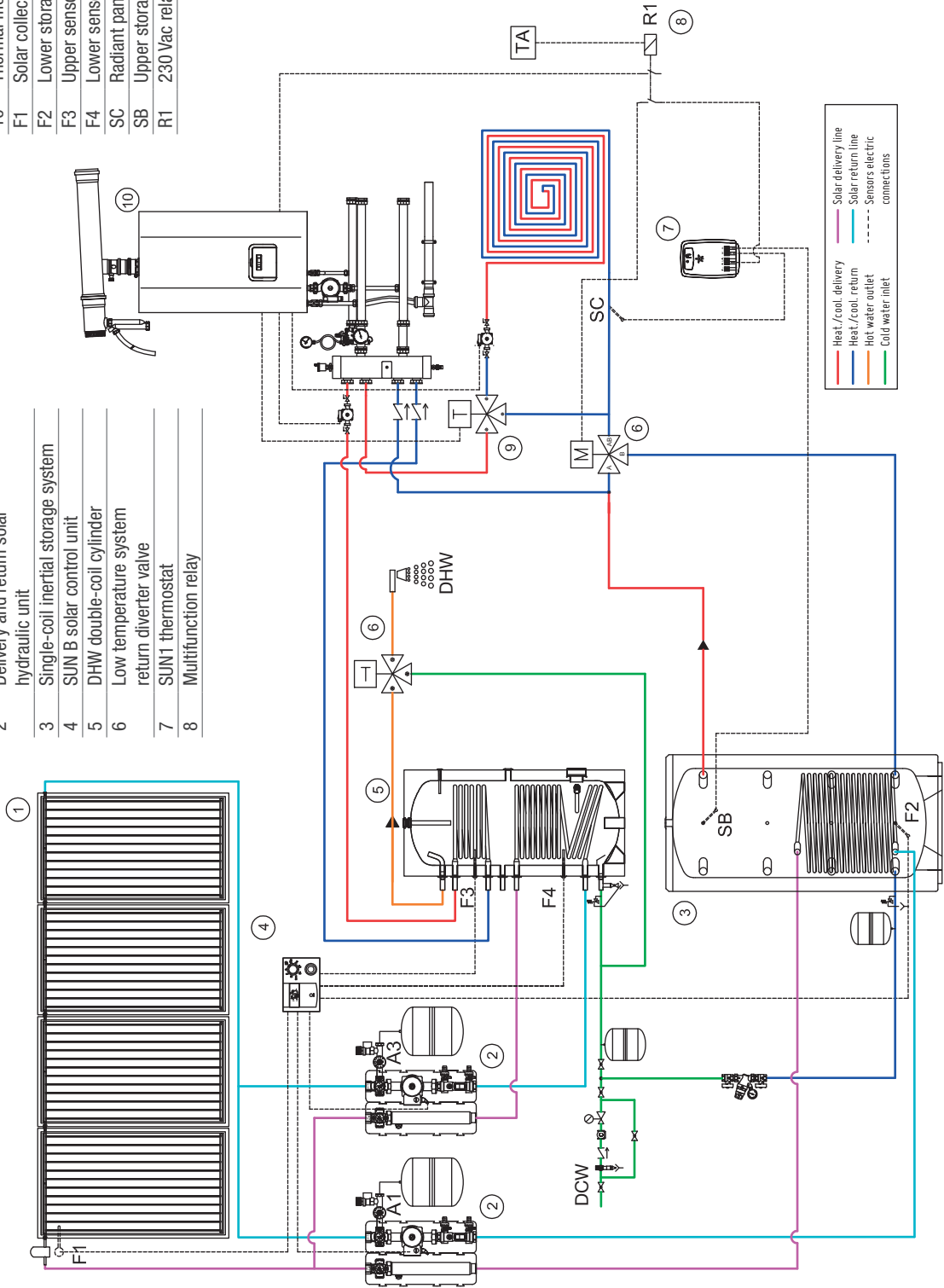

### Examples of solar thermal systems

#### Heating system with condensing module, solar integration to the storage tank and metering

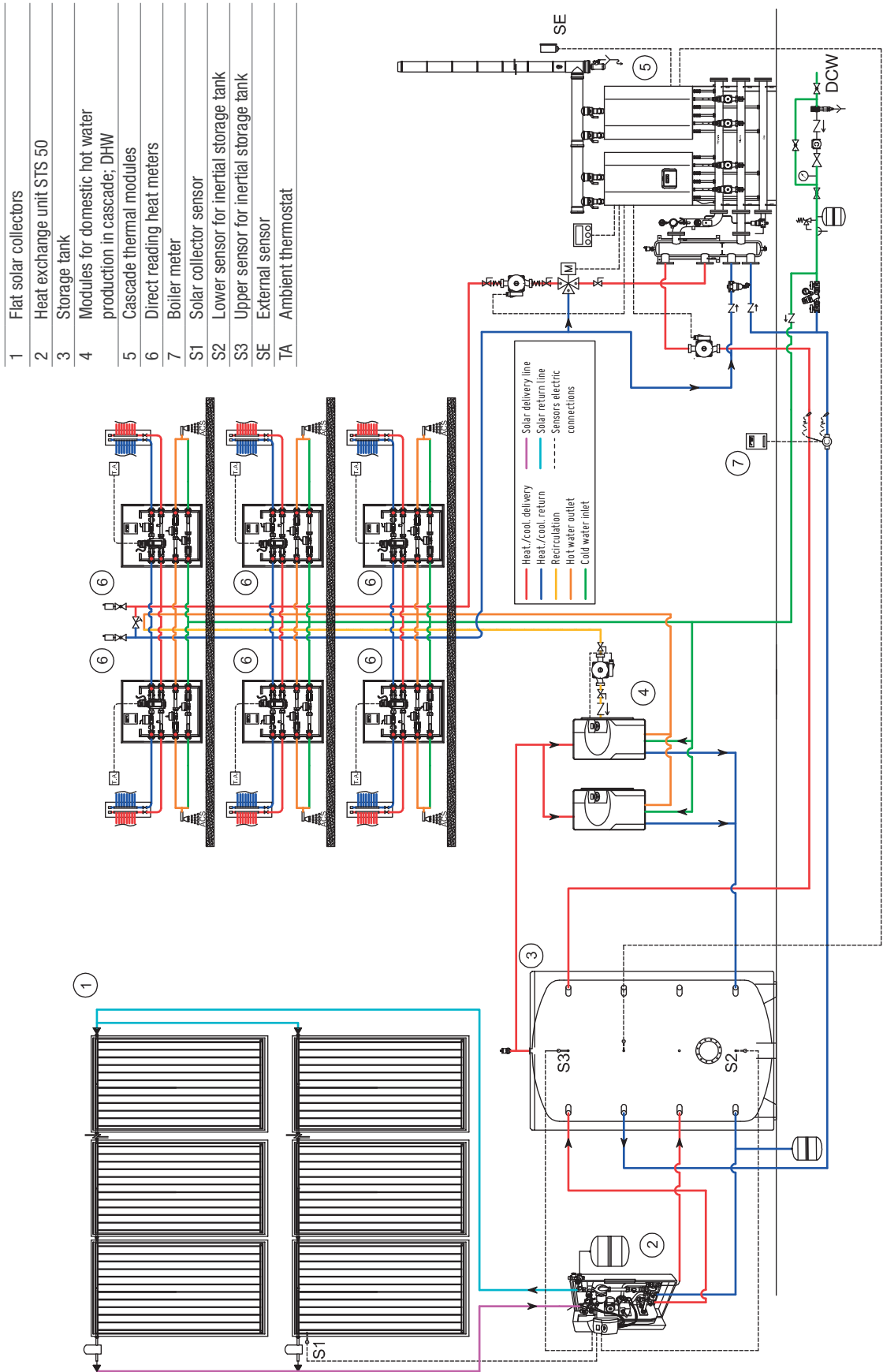

Examples of solar thermal systems

Heating system with indoor condensing module, 2 mixed circuits and 1 direct circuit, solar thermal system

1	Flat solar collectors
2	Delivery and return solar hydraulic unit
3	DHW double-coil cylinder
4	Control unit for system management CONTROL SYSTEM V3
5	Volumetric boiler meter
6	Cascade thermal modules
F3	Direct zone ambient thermostat sensor
FS	Radiant panels system sensor - Zone 1
F6	Upper sensor for DHW cylinder
F8	Collector sensor for thermal modules delivery
F9	External sensor
F11	Radiant panels system sensor - Zone 2
F12	Lower sensor for DHW cylinder
F13	Ambient thermostat sensor - Zone 1
F14	Solar collector sensor
F17	Ambient thermostat sensor - Zone 2
TA	Ambient thermostat

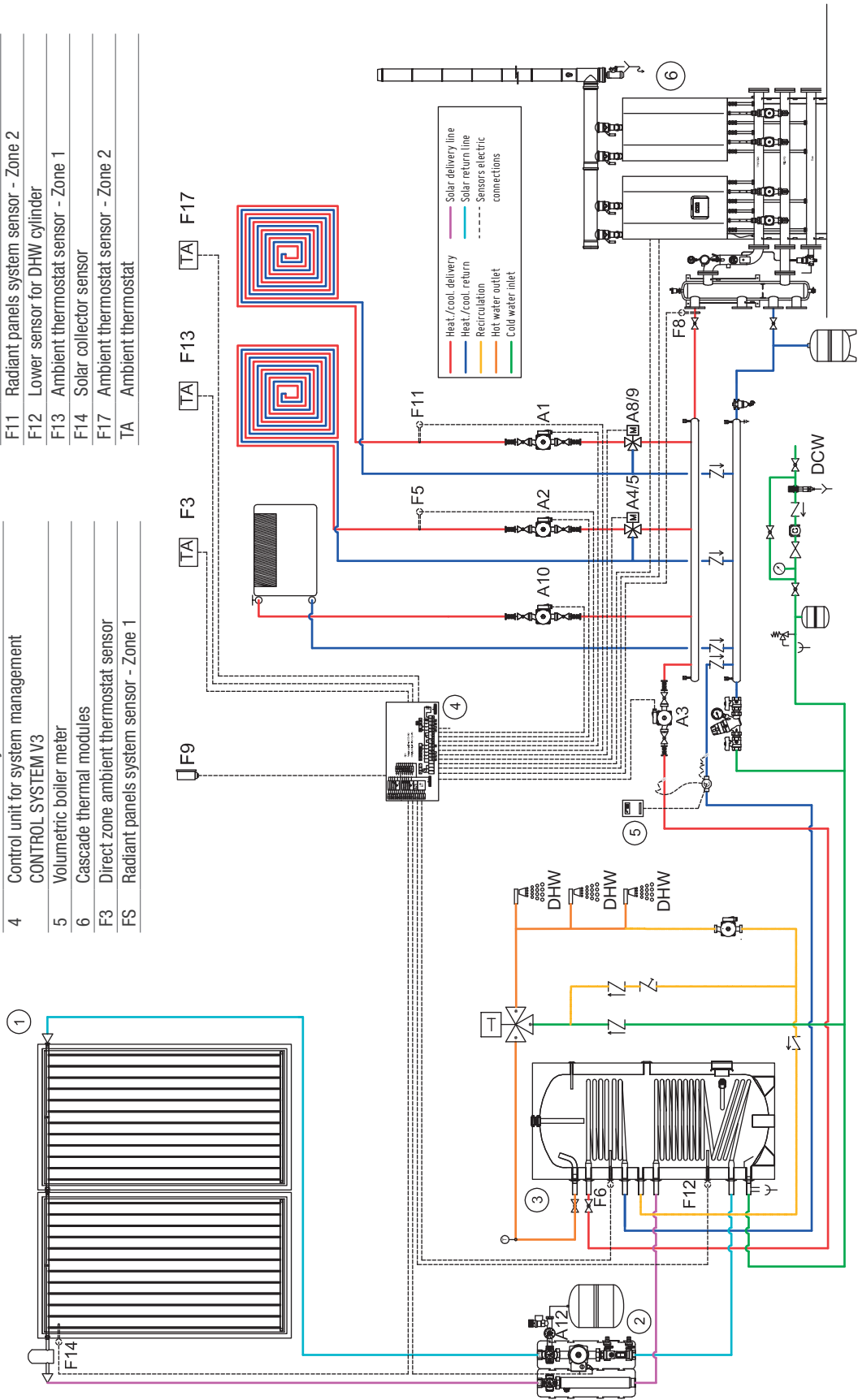

Examples of solar thermal systems

Hybrid system with heat pump and heating-only boiler for integration with the heating system and the double-coil solar cylinder for DHW production

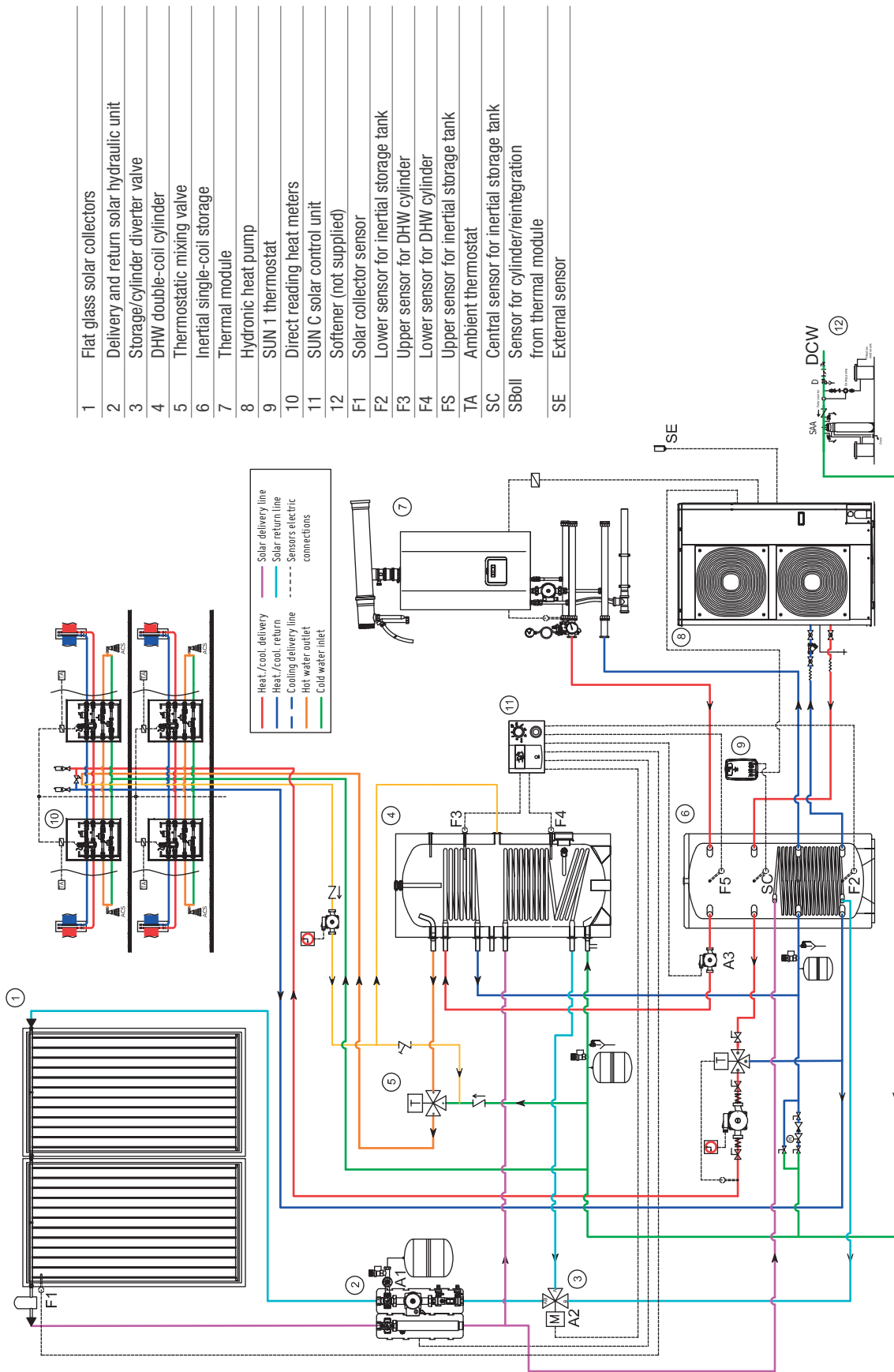

- 1 Flat glass solar collectors
- 2 Delivery and return solar hydraulic unit
- 3 Storage/cylinder diverter valve
- 4 DHW double-coil cylinder
- 5 Thermostatic mixing valve
- 6 Inertial single-coil storage
- 7 Thermal module
- 8 Hydronic heat pump
- 9 SUN 1 thermostat
- 10 Direct reading heat meters
- 11 SUN C solar control unit
- 12 Softener (not supplied)
- F1 Solar collector sensor
- F2 Lower sensor for inertial storage tank
- F3 Upper sensor for DHW cylinder
- F4 Lower sensor for DHW cylinder
- F5 Upper sensor for inertial storage tank
- TA Ambient thermostat
- SC Central sensor for inertial storage tank
- SBoll Sensor for cylinder/reintegration from thermal module
- SE External sensor







RIELLO S.p.A.  
Via Ing. Pilade Riello, 7  
37045 Legnago (VR) – Italy  
tel. +39 0442 630111

[www.berettaheating.com](http://www.berettaheating.com)



Beretta reserves the right to change the information and specifications contained herein at any time and without notice. The contents and information provided herein are for informational purposes only and are not intended to provide legal or professional advice. This document, therefore, cannot be considered binding on third parties.

© Riello S.p.A. All rights reserved