

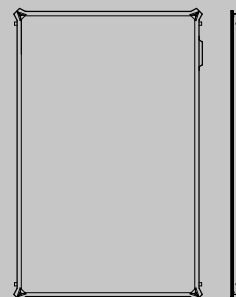

RPS 20/4 A – 25/4 A

Vertical flat solar collectors

Vertical installation
RPS 20 (2 m²) – RPS 25 (2,5 m²)
Structure with galvanized steel frame pre-painted
Copper harp absorber
4 connections



Vertical flat solar collectors

Solar thermal and DHW tanks

RPS 20/4 A – 25/4 A

PRODUCT DESCRIPTION

The RPS A solar collectors, which can be installed in a vertical position, are equipped with a highly selective aluminum absorber with TiNO_x treatment and a dense laser-welded copper harp which allow an energy absorption of solar radiation of 95%.

- The solar glass is tempered, prismatic type and ensures high transmissivity.
- The insulation is made of glass wool, 30 mm thick and is positioned in the lower part. The glass and insulation ensures high performance even in the presence of less than optimal weather conditions.
- 4 x 1" connections to tighten.
- Possibility of connecting up to 10 collectors vertically in series.
- Solar Keymark certified.
- Wide range of accessories and fixing systems to ensure maximum installation versatility.
- 5 year guarantee.

TECHNICAL DATA RPS 20/4 A – 25/4 A

Model	OFM	RPS 20/4 A	RPS 25/4 A
AG gross surface area	m ²	2,000	2,500
Aa opening surface	m ²	1,910	2,390
Effective absorber surface	m ²	1,900	2,370
Connections	mm	22	22
Empty weight	kg	29,15	35,4
Liquid content	l	1,38	1,55
Recommended flow rate for each line per m ² of solar collector (4)	l/(hxm ²)	30	30
Minimum flow rate for each line per m ² of solar collector	l/(hxm ²)	20	20
Maximum flow rate for each line per m ² of solar collector	l/(hxm ²)	60	60
Glass thickness	mm	3,2	3,2
Glass wool insulation thickness	mm	30	30
Absorption (α)	%	95	95
Emissivity (ε)	%	4	4
Maximum allowed pressure	bar	10	10
Stagnation temperature	°C	180	180
Maximum number of collectos in a line	no	10	10
Installation	-	Vertical	Vertical
Würzburg Input T _m 25°C (3)	kWh/year	1470	1837
Würzburg Input Q _{col} T _m 50°C (3)	kWh/year	947	1184
Würzburg Input Q _{col} T _m 75°C (3)	kWh/year	522	652
Specific Productivity (3)	kWh/m ² year	473,5	473,6
Optical efficiency (η _o) (1)	%	76,2	77
Heat loss coefficient (a ₁) (1)	W/(m ² K)	2,99	3,18
Heat loss coefficient (a ₂) (1)	W/(m ² K)	0,027	0,021
IAM (50°) (1)	-	0,91	0,91
Collector efficiency (η _{col}) (2)	%	60	60

(1) Value referred to gross surface area. Test according to ISO 9806, referring to a 33,3% water-glycol mixture, flow rate of 160 l/h and irradiation G = 800W/m².
 $T_m = (T_{coll_inlet} + T_{coll_outlet}) / 2 - T^*m = (T_m - T_{room}) / G$

(2) Calculated at a temperature difference of 40°K between the solar collector and the surrounding ambient air, with global solar radiation, referred to the opening area, 1000 W/m².

(3) Würzburg location, data obtained from the report of the collector.

(4) Recommended flow rate in the medium/cold climate range.

SOLAR COLLECTOR PRESSURE DROP

Single collector load losses (33,3% glycol)

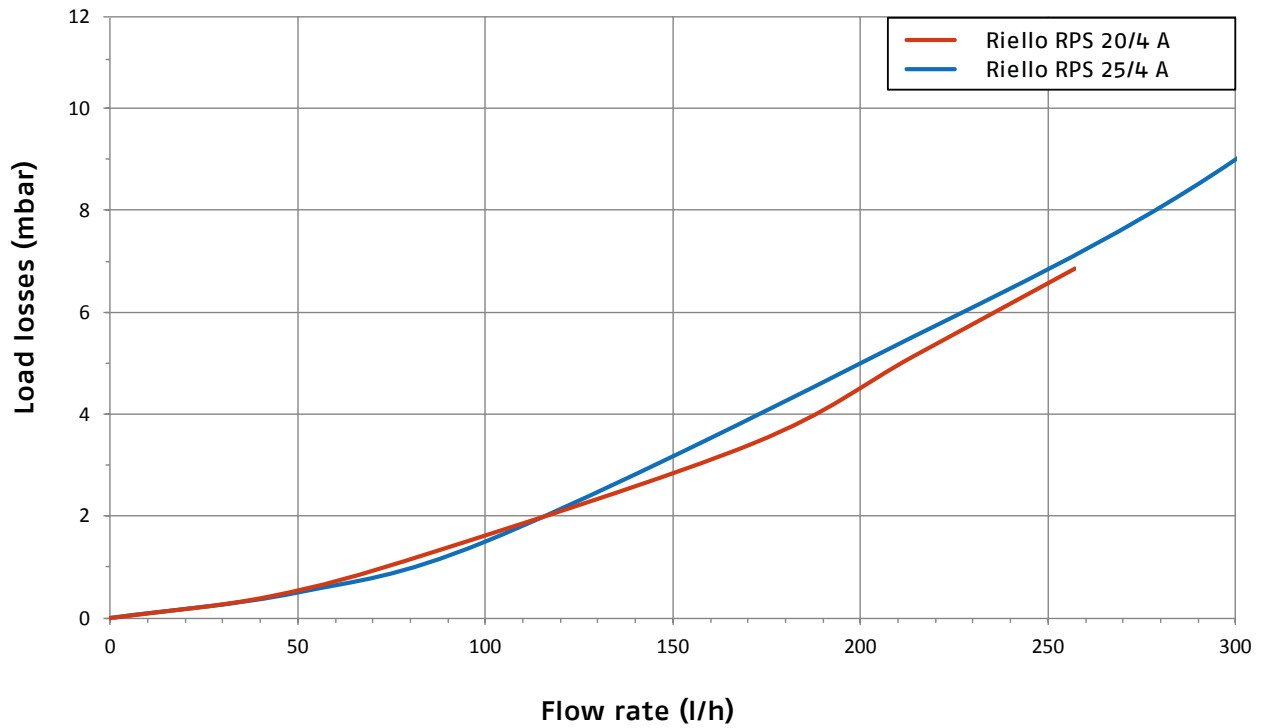

Vertical flat solar collectors

Solar thermal and DHW tanks

EFFICIENCY CURVE

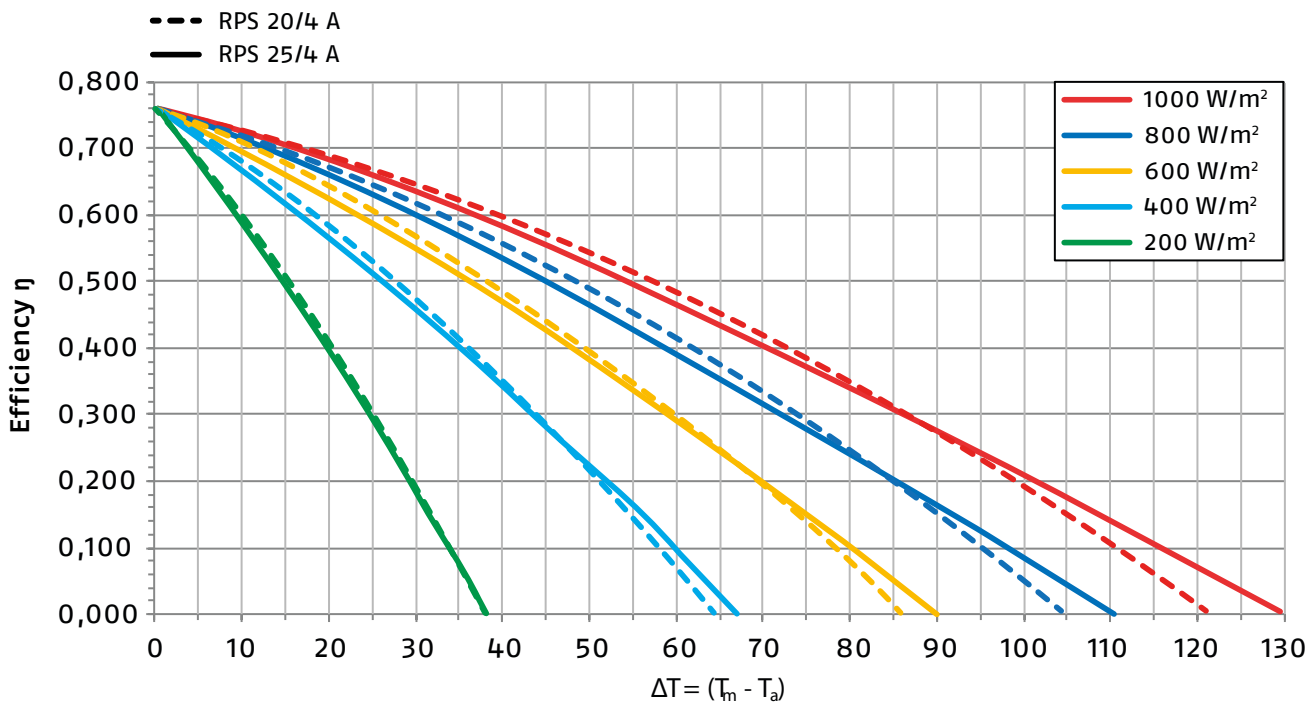

OUTPUT CURVE

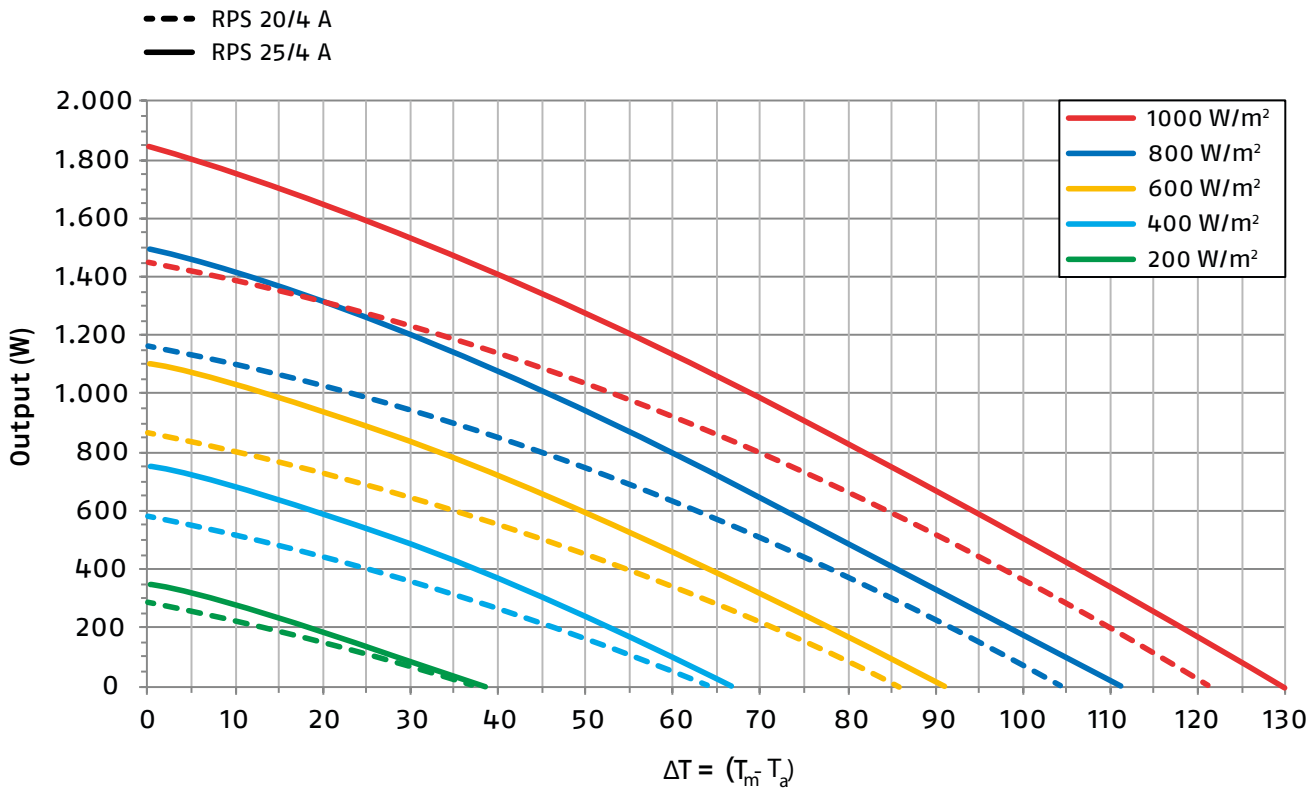

T_m = average collector temperature
 T_a = external ambient temperature

STRUCTURE AND OVERALL DIMENSIONS

RPS 20/4 A COLLECTOR

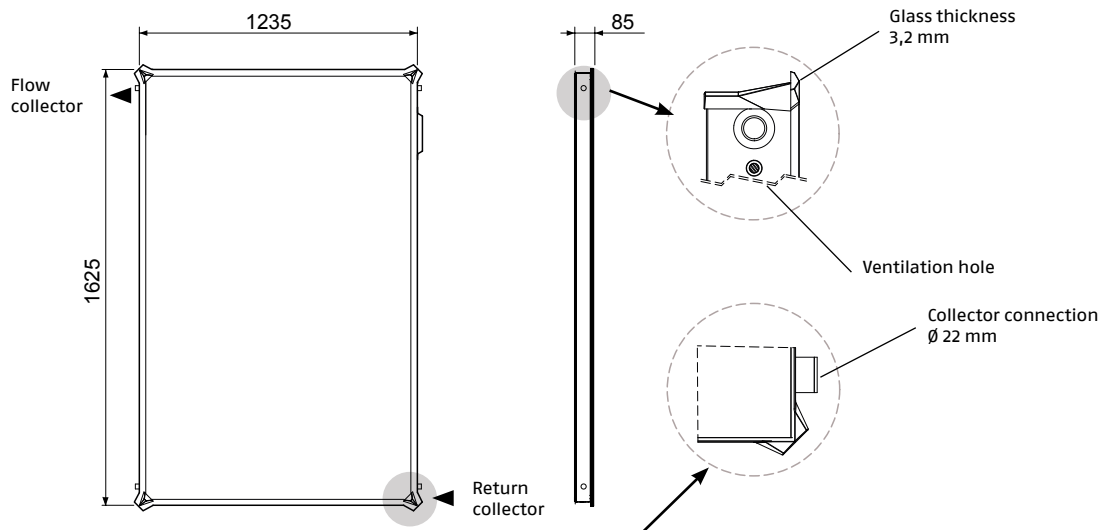

RPS 25/4 A COLLECTOR

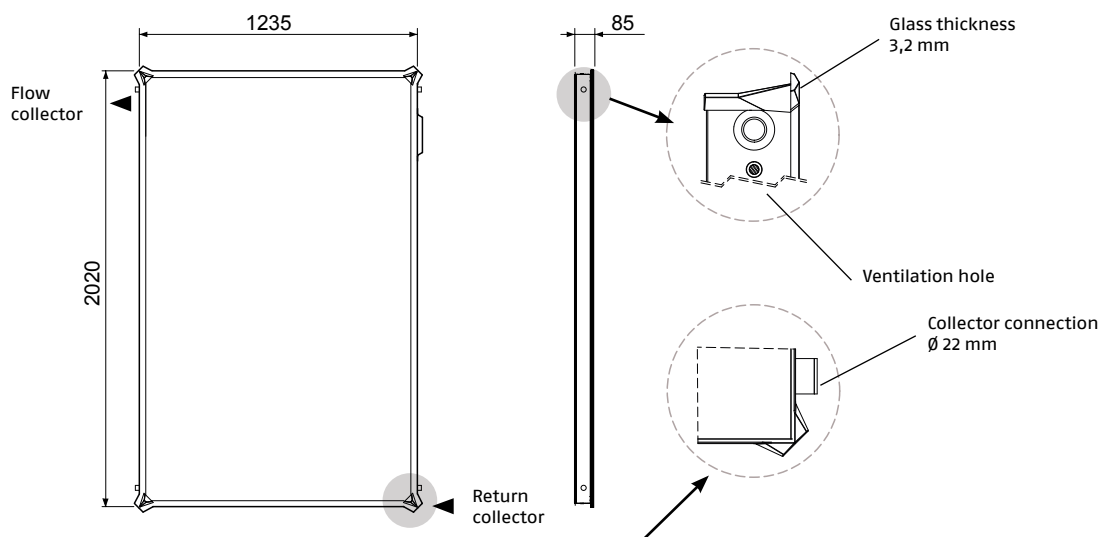

Vertical flat solar collectors

Solar thermal and DHW tanks

POSITIONING OF PROBES

The temperature sensor must be installed in the pocket located on the cap on the collector delivery pipe. Only materials with suitable resistance to high temperatures (over 214°C for sensor element, contact paste, cables, gasket materials, insulation) may be used for sensor mounting

1. Solar collector
2. Cylinder
3. Collector probe
4. Shut-off valve
5. Non-return valve
6. Temperature pressure gauge
7. Vent valve
8. Safety valve
9. Pressure gauge
10. Drainage
11. Expansion vessel
12. pump
13. Flow Regulator
14. Flow meter
15. Vent cock
16. Manual degasser (accessory)
17. Recovery of heat transfer fluids

M. Collector flow
R. Collector return

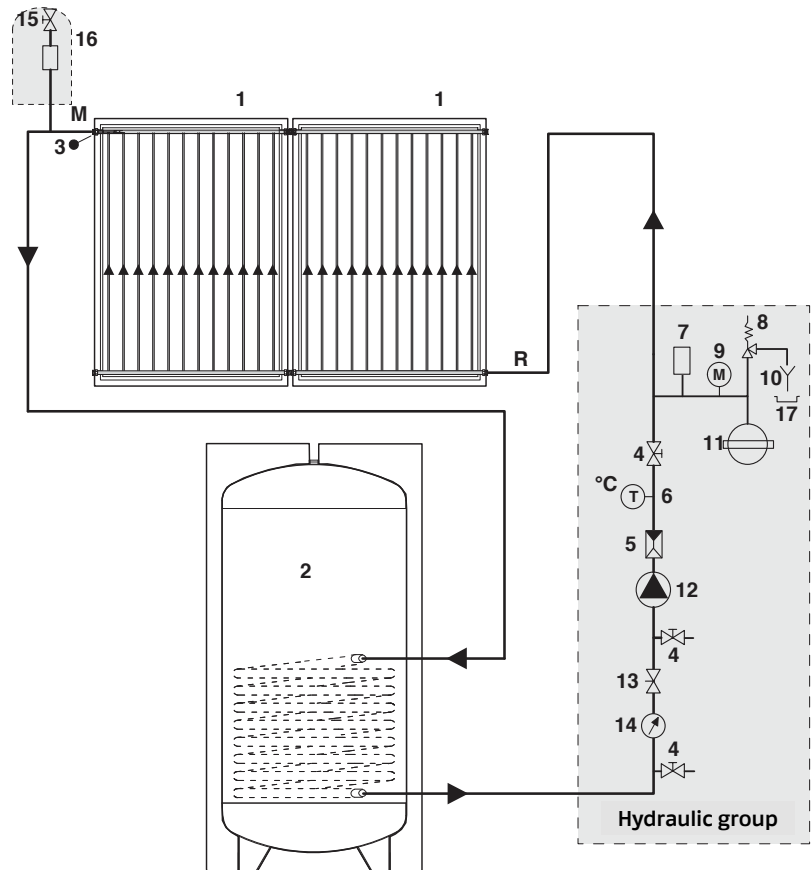

We recommend using stainless steel pipes designed for solar collectors (flow, return and tube for the probe).
A shielded probe cable is recommended.
If copper pipes are used, perform strong brazing.
Do not use plastic or multilayer pipes: the operating temperature can exceed 180°C.
The insulation of the pipes must resist high temperatures (180°C).
To prevent undue heat loss, insert a check valve on the solar collector return near the storage tank.

ASSEMBLY OF SOLAR COLLECTORS

To check the allowable loads, contact a specialized technician.

In case of installation on flat roofs that cannot be drilled, use ballast (not supplied) equally distributed on all support points, as shown in the figure.

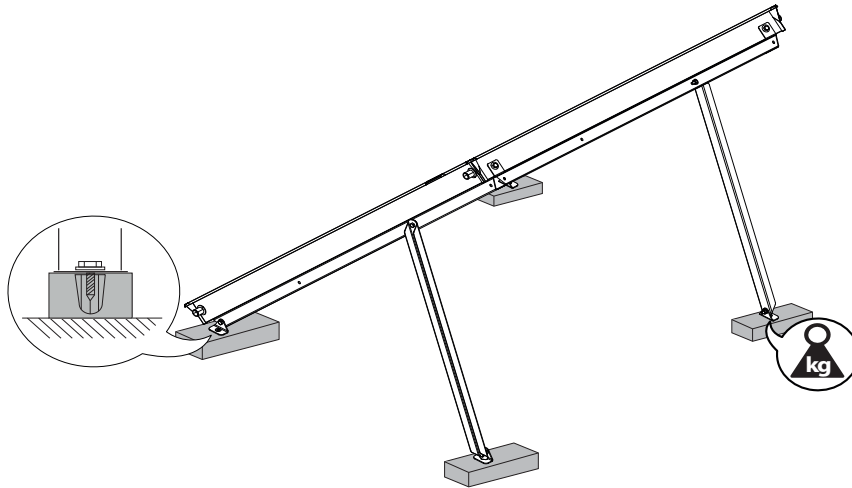

Wind speed km/h	Angle of inclination of the solar collectors	Mass in kg, distributed on the various bearing points, to secure a collector from wind lifting
100	30°-45°	135
130	30°-45°	255
150	30°-45°	355

PRECHARGE PRESSURE DIAGRAM

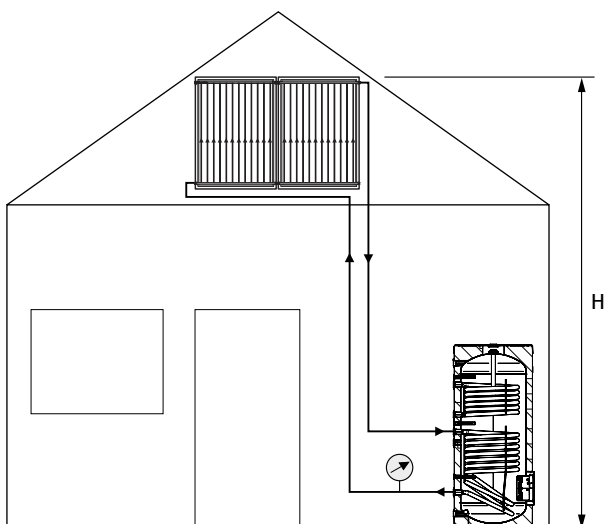

H	Pressure in thermal system plant
up to 15 m	3 bar
15 - 20 m	3,5 bar
20 - 25 m	4 bar
25 - 30 m	4,5 bar

Vertical flat solar collectors

Solar thermal and DHW tanks

HYDRAULIC CONNECTIONS

During installation, pay attention to the position of the probe in relation to the collector. The collector probe must always be located at the top of the panel, as indicated in the following figures.

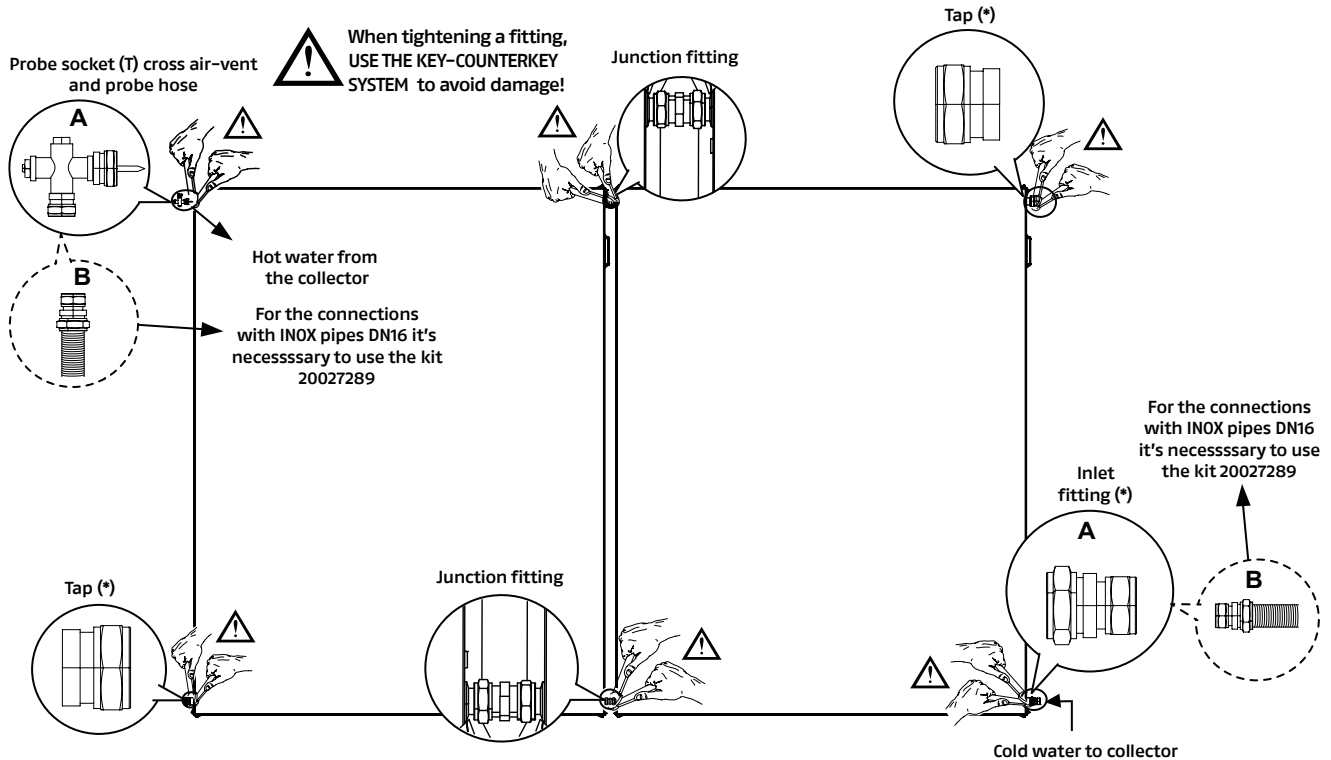

(*) The connections can also be mirrored. The rule states that the probe holder connection is always located on the upper part of the collectors while the inlet connection is on the lower part.

NB: to connect the panel with a stainless steel pipe, an 18 mm section of copper pipe must be installed between fittings A (contained in code **20201448**) and B (contained in code **20027289**).

The collectors are connected to each other so that the heat transfer fluid passes through them in parallel. The connection with the heat exchange circuit towards the exchanger must be made on the side of the probe well (T) of the last manifold in the series (see figure). The positioning of the well on the collector allows maximum transfer of the heat accumulated in the panels.

It is also possible to connect more than one line of solar collectors, both in series (provided the number of solar collectors for each series does not exceed 10 units) or in parallel. In any case the circuit must be hydraulically balanced (see the following diagrams as an example).

PREMIXING WATER + GLYCOL

The glycol is supplied separately in standard packages and must be mixed with water in a container before filling the system (for example 40% glycol and 60% water allow frost resistance up to a temperature of -21°C).

The propylene glycol supplied is specifically designed for solar applications as it retains its characteristics in the range $-32\pm 180^{\circ}\text{C}$. It is also non-toxic, biodegradable and biocompatible. Do not put pure glycol into the system and then add water. Do not use manual or automatic filling systems. In the presence of a very high chlorine content it is necessary to use distilled water for the mixture.

Antifreeze	Domestic hot water	Density
50%	-32°C	1,045 kg/dm ³
40%	-21°C	1,037 kg/dm ³
30%	-13°C	1,029 kg/dm ³

The collector is affected by the radiation of the celestial vault and therefore in winter, during the night, the panel reaches lower temperatures

INSTALLATION ON FLAT ROOF

The flat roof bracket accessory allows the installation of a panel on a flat roof offering the possibility of installing the panel with two different inclinations, 45° or 30°.

It is made up of two support bars for the panel and two bars for supporting the bracket itself.

In the case of installations of multiple solar collectors, simply add the additional bracket kit to the basic kit.

Below we report the overall dimensions depending on the number of connected solar collectors.

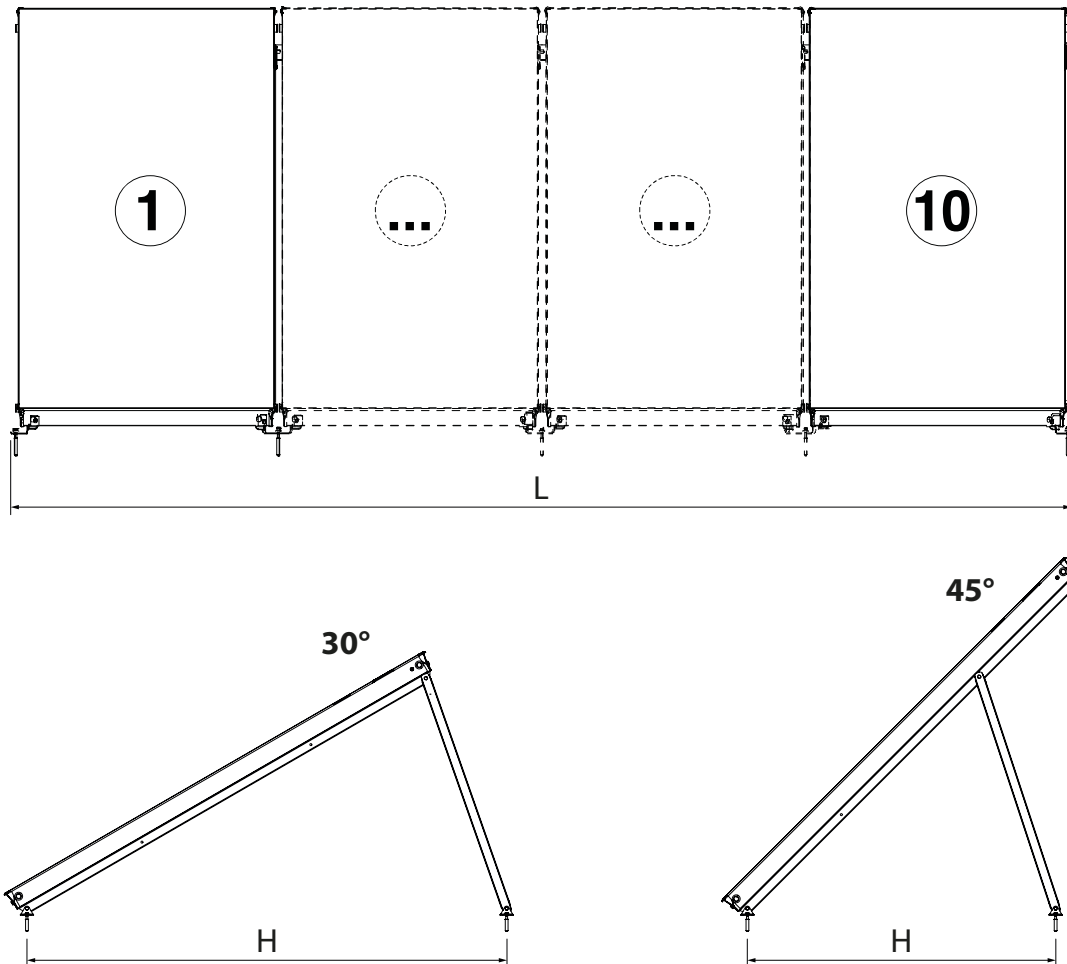

Number of collectors			1	2	3	4	5	6	7	8	9	10
RPS 20/4 A collector	L quote	m	1,27	2,54	3,81	5,08	6,35	7,62	8,89	10,16	11,43	12,7
	H 30° quote	m						1,62				
	H 45° quote	m						1,05				
RPS 25/4 A collector	L quote	m	1,27	2,54	3,81	5,08	6,35	7,62	8,89	10,16	11,43	12,7
	H 30° quote	m						2				
	H 45° quote	m						1,29				

Vertical flat solar collectors

Solar thermal and DHW tanks

BRACKETS KIT FOR SINGLE COLLECTOR

Tables B and C express the quantities and types of components to order depending on the configuration of chosen installation.

B TABLE
2,0m² COLLECTORS

	BRACKETS for 1x2m ² collector "A" type TP 30-45°	BRACKETS +1x2m ² collectors "A" type TP 30-45°	hydraulic kit for 1 collector "A" type	hydraulic kit for 2 collectors "A" type	hydraulic kit for 3 collectors "A" type	hydraulic kit for 4 collectors "A" type	hydraulic kit for 5 collectors "A" type	hydraulic kit for 6 collectors "A" type	hydraulic kit for 7 collectors "A" type	hydraulic kit for 8 collectors "A" type	hydraulic kit for 9 collectors "A" type	hydraulic kit for 10 collectors "A" type
kit for 1 x 2m ² Collector TP 30-45°	1		1									
kit for 2 x 2m ² Collectors TP 30-45°	1	1		1								
kit for 3 x 2m ² Collectors TP 30-45°	1	2			1							
kit for 4 x 2m ² Collectors TP 30-45°	1	3				1						
kit for 5 x 2m ² Collectors TP 30-45°	1	4					1					
kit for 6 x 2m ² Collectors TP 30-45°	1	5						1				
kit for 7 x 2m ² Collectors TP 30-45°	1	6							1			
kit for 8 x 2m ² Collectors TP 30-45°	1	7								1		
kit for 9 x 2m ² Collectors TP 30-45°	1	8									1	
kit for 10 x 2m ² Collectors TP 30-45°	1	9										1

B TABLE
2,5m² COLLECTORS

	BRACKETS for 1 2,5m ² Collector "A" type TP 30-45°	BRACKETS +1 2,5m ² Collector "A" type TP 30-45°	hydraulic kit for 1 collector "A" type	hydraulic kit for 2 collectors "A" type	hydraulic kit for 3 collectors "A" type	hydraulic kit for 4 collectors "A" type	hydraulic kit for 5 collectors "A" type	hydraulic kit for 6 collectors "A" type	hydraulic kit for 7 collectors "A" type	hydraulic kit for 8 collectors "A" type	hydraulic kit for 9 collectors "A" type	hydraulic kit for 10 collectors "A" type
kit for 1 x 2,5m ² Collector TP 30-45°	1		1									
kit for 2 x 2,5m ² Collectors TP 30-45°	1	1		1								
kit for 3 x 2,5m ² Collectors TP 30-45°	1	2			1							
kit for 4 x 2,5m ² Collectors TP 30-45°	1	3				1						
kit for 5 x 2,5m ² Collectors TP 30-45°	1	4					1					
kit for 6 x 2,5m ² Collectors TP 30-45°	1	5						1				
kit for 7 x 2,5m ² Collectors TP 30-45°	1	6							1			
kit for 8 x 2,5m ² Collectors TP 30-45°	1	7								1		
kit for 9 x 2,5m ² Collectors TP 30-45°	1	8									1	
kit for 10 x 2,5m ² Collectors TP 30-45°	1	9										1

NOTE: Check the ability of the roof structure to support the load of the operating solar collector with the building builder or contact local authorities.
TP = Flat roof

INSTALLATION ON PITCHED ROOF

The pitched roof bracket accessory allows the installation of a collector on a sloped pitch and can be used for both 2 and 2,5m² collectors.

The type of installation is with an under-tile connection to which a junction element is added which allows you to connect the two collectors supports and therefore keep them still during their connection. In the case of installations of multiple solar collectors, simply add the additional bracketing kit to the 2 collector bracketing kit.

Below we report the overall dimensions depending on the number of connected solar collectors.

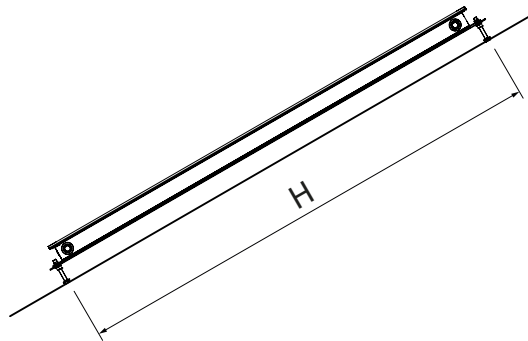
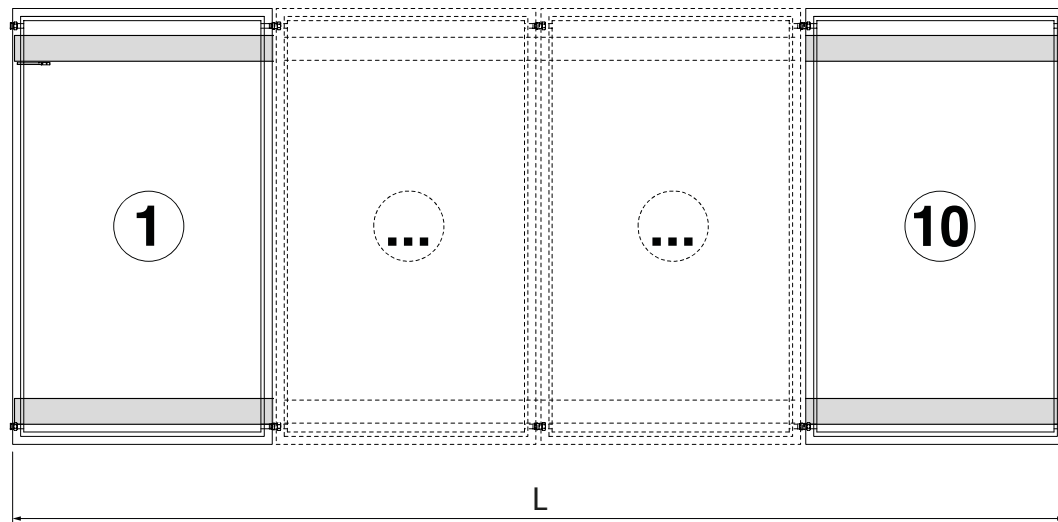

Number of collectors			1	2	3	4	5	6	7	8	9	10
RPS 20/4 A collector	L quote	m	1,27	2,54	3,81	5,08	6,35	7,62	8,89	10,16	11,43	12,7
	H quote	m	2									
RPS 25/4 A collector	L quote	m	1,27	2,54	3,81	5,08	6,35	7,62	8,89	10,16	11,43	12,7
	H quote	m	2,4									

Vertical flat solar collectors

Solar thermal and DHW tanks

PITCHED ROOF INSTALLATION

BRACKETS KIT FOR SINGLE COLLECTOR

Table A shows the quantities and types of components to order depending on the installation configuration chosen.

A TABLE 2,0m ² – 2,5m ² COLLECTORS		BRACKETS 1x2–2,5m ² Collector "A" type	BRACKETS 2x2–2,5m ² Collectors "A" type	BRACKETS 4x2–2,5m ² Collectors "A" type	kit of 4 hooks for TI brackets –Collector "A"	kit of 6 hooks for TI brackets –Collector "A"	hydraulic kit for 1 collector "A" type	hydraulic kit for 2 collectors "A" type	hydraulic kit for 3 collectors "A" type	hydraulic kit for 4 collectors "A" type	hydraulic kit for 5 collectors "A" type	hydraulic kit for 6 collectors "A" type	hydraulic kit for 7 collectors "A" type	hydraulic kit for 8 collectors "A" type	hydraulic kit for 9 collectors "A" type	hydraulic kit for 10 collectors "A" type	
		TI under tile	TI under tile	TI under tile													
kit for 1 x 2–2,5m ² Collector	TI	1			1		1										
kit for 2 x 2–2,5m ² Collectors	TI		1			1		1									
kit for 3 x 2–2,5m ² Collectors	TI		1	1	1	1			1								
kit for 4 x 2–2,5m ² Collectors	TI		1	2	2	1				1							
kit for 5 x 2–2,5m ² Collectors	TI		1	3	3	1					1						
kit for 6 x 2–2,5m ² Collectors	TI		1	4	4	1						1					
kit for 7 x 2–2,5m ² Collectors	TI		1	5	5	1							1				
kit for 8 x 2–2,5m ² Collectors	TI		1	6	6	1								1			
kit for 9 x 2–2,5m ² Collectors	TI		1	7	7	1									1		
kit for 10 x 2–2,5m ² Collectors	TI		1	8	8	1											1

NOTE: Check the ability of the roof structure to support the load of the operating solar collector with the building builder or contact local authorities.
TI = Pitched roof

PRODUCT DESCRIPTION FOR SPECIFICATIONS

RPS 20/4 A SOLAR COLLECTOR

The solar collector for vertical installation is composed of:

- Gross surface area from 2,0m²
- Effective absorber surface 1,90m²
- Absorber made up of an aluminum collecting plate with selective TiNOx energy Al finish.
- Energy absorption equal to 0,95
- Emission 0,04
- Internal hydraulic circuit composed of 2 DN22 copper collectors to which the harp, also made of copper, is laser welded, consisting of 12 DN8 pipes which develop generating a single thermal length, all welded using ultrasound with the absorber in aluminum to obtain a high yield of the solar collector; the copper harp is slightly bent at the DN22 collectors to maximize the effective exchange surface between the absorber and the DN8 pipes containing the heat transfer fluid.
- 4 x 22mm diameter copper connections with tightening fittings.
- Possibility of connecting up to 10 collectors in series (vertical installation).
- Frame composed of high quality galvanized steel, pre-painted for maximum resistance to corrosion and aggressive/marine environments, with a thickness of 0,42mm.
- 30mm rock wool insulation, density 40 kg/m³, which allows high performance even at low temperatures.
- Clear tempered prismatic glass with low iron content. It is of the mistlite type, so it has a rough appearance to the eye. Its thickness is 3,2mm and is fixed to the frame using a polymeric material called Colofast®. Colofast® offers a perfect junction between glass and frame, ensuring robustness but at the same time flexibility. Furthermore, this type of joint makes the panel perfectly impervious to atmospheric agents and gives it a perfect finish.

PRODUCT DESCRIPTION FOR SPECIFICATIONS

RPS 25/4 A SOLAR COLLECTOR

The solar collector for vertical installation is composed of:

- Gross surface area of 2,5m²
- Effective absorber surface of 2,37m²
- Absorber made up of an aluminum collecting plate with selective TiNOx energy Al finish.
- Energy absorption equal to 0,95
- Emission 0,04
- Internal hydraulic circuit composed of 2 DN22 copper manifolds to which the harp, also made of copper, is laser welded, consisting of 12 DN8 pipes which develop generating a single thermal length, all welded using ultrasound with the absorber in aluminum to obtain a high yield of the solar collector; the copper harp is slightly bent at the DN22 collectors to maximize the effective exchange surface between the absorber and the DN8 pipes containing the heat transfer fluid.
- 4 x 22mm diameter copper connections with tightening fittings.
- Possibility of connecting up to 10 collectors in series (vertical installation).
- Frame composed of high quality galvanized steel, pre-painted for maximum resistance to corrosion and aggressive/marine environments, with a thickness of 0,42mm.
- 30mm rock wool insulation, density 40 kg/m³, which allows high performance even at low temperatures.
- Clear tempered prismatic glass with low iron content. It is of the mistlite type, so it has a rough appearance to the eye. Its thickness is 3,2mm and is fixed to the frame using a polymeric material called Colofast®. Colofast® offers a perfect junction between glass and frame, ensuring robustness but at the same time flexibility. Furthermore, this type of joint makes the panel perfectly impervious to atmospheric agents and gives it a perfect finish.

RIELLO

RIELLO S.p.A.
Via Ing. Pilade Riello, 7
37045 Legnago (VR)
tel. +39 0442 630111

www.riello.com



As the company is constantly engaged in the continuous improvement of its entire production, the aesthetic and dimensional features, technical data, equipment and accessories can be subject to variation.



RPS 20/4 A



RPS 25/4 A



©2026 Carrier. All Rights Reserved.
All trademarks and service marks referred herein
are property of their respective owners.