

GB **Dual fuel air atomizing oil/gas burners**

Modulating operation

CODE	MODEL
20164347 - 20164348	RLAS 1000/EV (FGR prepared)
20164351 - 20164352	RLAS 1200/EV (FGR prepared)



Original instructions

1	Information and general instructions	3
1.1	Information about the instruction manual	3
1.2	Guarantee and responsibility	4
2	Safety and prevention	5
2.1	Introduction	5
2.2	Personnel training	5
3	Technical description of the burner	6
3.1	Technical data	6
3.2	Electrical data	6
3.3	Burner models designation	6
3.4	Burner equipment	7
3.5	Packaging	7
3.6	Overall dimensions	8
3.7	Burner capacity	9
3.8	Minimum furnace dimensions	10
3.9	Burner components	11
3.10	Panel board description	12
3.11	AZL display	13
3.12	Flame control (LMV52...)	14
3.13	Servomotor (SQM48.4...)	19
4	Installation	20
4.1	Notes on safety for the installation	20
4.2	Handling	20
4.3	Preliminary checks	20
4.4	Operating position	21
4.5	Removing the shutter lockout screws	21
4.6	Preparing the boiler	21
4.7	Securing the burner to the boiler	22
4.8	Access to head internal part	22
4.9	Combustion head adjustment	23
4.10	Electrode position	24
4.11	Nozzle installation	24
4.12	Light oil supply	26
4.13	Pump	28
4.14	Gas train supplied	29
4.15	Electrical wiring	31
4.16	Installation of shielded cables	34
4.17	Thermal relay calibration	36
4.18	Motor connection at 460V	37
5	Start-up, calibration and operation of the burner	38
5.1	Notes on safety for the first start-up	38
5.2	Adjustments before first firing (light oil operation)	38
5.3	Fuel change	38
5.4	Adjustments before first firing (gas operation)	38
5.5	Burner start-up	39
5.6	Burner firing	39
5.7	Burner ignition	40

5.8	Final calibration of the pressure switches	41
5.9	Final checks (with the burner working)	42
6	Maintenance	43
6.1	Notes on safety for the maintenance	43
6.2	Maintenance programme	43
6.3	Checking the position of the rpm sensor	46
6.4	Opening the burner	46
6.5	Closing the burner	46
7	Faults - Possible causes - Solutions	47
A	Appendix - Spare parts	48

1 Information and general instructions

1.1 Information about the instruction manual

1.1.1 Introduction

The instruction manual supplied with the burner:

- is an integral and essential part of the product and must not be separated from it; it must therefore be kept carefully for any necessary consultation and must accompany the burner even if it is transferred to another owner or user, or to another system. If the manual is lost or damaged, another copy must be requested from the Technical Assistance Service of the area;
- is designed for use by qualified personnel;
- offers important indications and instructions relating to the installation safety, start-up, use and maintenance of the burner.

Symbols used in the manual

In some parts of the manual you will see triangular DANGER signs. Pay great attention to these, as they indicate a situation of potential danger.

1.1.2 General dangers

The **dangers** can be of **3 levels**, as indicated below.



Maximum danger level!
This symbol indicates operations which, if not carried out correctly, cause serious injury, death or long-term health risks.



This symbol indicates operations which, if not carried out correctly, may cause serious injury, death or long-term health risks.



This symbol indicates operations which, if not carried out correctly, may cause damage to the machine and/or injury to people.

1.1.3 Other symbols



DANGER: LIVE COMPONENTS
This symbol indicates operations which, if not carried out correctly, lead to electric shocks with lethal consequences.



DANGER: FLAMMABLE MATERIAL
This symbol indicates the presence of flammable materials.



DANGER: BURNING
This symbol indicates the risks of burns due to high temperatures.



DANGER: CRUSHING OF LIMBS
This symbol indicates the presence of moving parts: danger of crushing of limbs.



WARNING: MOVING PARTS

This symbol indicates that you must keep limbs away from moving mechanical parts; danger of crushing.



DANGER: EXPLOSION

This symbol signals places where an explosive atmosphere may be present. An explosive atmosphere is defined as a mixture - under atmospheric conditions - of air and flammable substances in the form of gases, vapours, mist or dust in which, after ignition has occurred, combustion spreads to the entire unburned mixture.



PERSONAL PROTECTION EQUIPMENT

These symbols indicate the equipment that must be worn and kept by the operator for protection against threats against safety and/or health while at work.



OBLIGATION TO ASSEMBLE THE COVER AND ALL THE SAFETY AND PROTECTION DEVICES

This symbol signals the obligation to reassemble the cover and all the safety and protection devices of the burner after any maintenance, cleaning or checking operations.



ENVIRONMENTAL PROTECTION

This symbol gives indications for the use of the machine with respect for the environment.



IMPORTANT INFORMATION

This symbol indicates important information that you must bear in mind.

- This symbol indicates a list.

Abbreviations used

Ch.	Chapter
Fig.	Figure
Page	Page
Sec.	Section
Tab.	Table

1.1.4 Delivery of the system and the instruction manual

When the system is delivered, it is important that:

- the instruction manual is delivered to the user by the system manufacturer, with the recommendation to keep it in the room where the heat generator is to be installed.
- The instruction manual shows:
 - the serial number of the burner;

.....

- the address and telephone number of the nearest Assistance Centre.

.....

- The system supplier must carefully inform the user about:
 - the use of the system;
 - any further tests that may be required before activating the system;
 - maintenance, and the need to have the system checked at least once a year by a representative of the manufacturer or another specialised technician. To ensure a periodic check, the manufacturer recommends the drawing up of a Maintenance Contract.

1.2 Guarantee and responsibility

The manufacturer guarantees its new products from the installation date, in accordance with the regulations in force and/or the sales contract. At the moment of the first start-up, check that the burner is integral and complete.



WARNING

Failure to observe the information given in this manual, operating negligence, incorrect installation and carrying out of non authorised modifications will result in the annulment by the manufacturer of the guarantee that it supplies with the burner.

In particular, the rights to the guarantee and the responsibility will no longer be valid, in the event of damage to things or injury to people, if such damage/injury was due to any of the following causes:

- incorrect installation, start-up, use and maintenance of the burner;
- improper, incorrect or unreasonable use of the burner;
- intervention of unqualified personnel;
- carrying out of unauthorised modifications on the equipment;
- use of the burner with safety devices that are faulty, incorrectly applied and/or not working;
- installation of untested supplementary components on the burner;
- powering of the burner with unsuitable fuels;
- faults in the fuel supply system;
- use of the burner even following an error and/or an irregularity;
- repairs and/or overhauls incorrectly carried out;
- modification of the combustion chamber with inserts that prevent the regular development of the structurally established flame;
- insufficient and inappropriate surveillance and care of those burner components most likely to be subject to wear and tear;
- the use of non-original components, including spare parts, kits, accessories and optional;
- force majeure.

The manufacturer furthermore declines any and every responsibility for the failure to observe the contents of this manual.

2 Safety and prevention

2.1 Introduction

The burners have been designed and built in compliance with current regulations and directives, applying the known technical rules of safety and envisaging all the potential danger situations.

It is necessary, however, to bear in mind that the imprudent and clumsy use of the equipment may lead to situations of death risk for the user or third parties, as well as the damaging of the burner or other items. Inattention, thoughtlessness and excessive confidence often cause accidents; the same applies to tiredness and sleepiness.

It is a good idea to remember the following:

- The burner must only be used as expressly described. Any other use should be considered improper and therefore dangerous.

In particular:

it can be applied to boilers operating with water, steam, diathermic oil, and to other users expressly named by the manufacturer;

the type and pressure of the fuel, the voltage and frequency of the electrical power supply, the minimum and maximum deliveries for which the burner has been regulated, the pressurisation of the combustion chamber, the dimensions of the combustion chamber and the room temperature must all be within the values indicated in the instruction manual.

- Modification of the burner to alter its performance and destinations is not allowed.
- The burner must be used in exemplary technical safety conditions. Any disturbances that could compromise safety must be quickly eliminated.
- Opening or tampering with the burner components is not allowed, apart from the parts requiring maintenance.
- Only those parts envisaged by the manufacturer can be replaced.



The manufacturer guarantees safety and proper functioning only if all burner components are intact and positioned correctly.

2.2 Personnel training

The user is the person, body or company that has acquired the machine and intends to use it for the specific purpose. He is responsible for the machine and for the training of the people working around it.

The user:

- undertakes to entrust the machine exclusively to suitably trained and qualified personnel;
- undertakes to inform his personnel in a suitable way about the application and observance of the safety instructions. With that aim, he undertakes to ensure that everyone knows the use and safety instructions for his own duties;
- Personnel must observe all the danger and caution indications shown on the machine.
- Personnel must not carry out, on their own initiative, operations or interventions that are not within their province.
- Personnel must inform their superiors of every problem or dangerous situation that may arise.
- The assembly of parts of other makes, or any modifications, can alter the characteristics of the machine and hence compromise operating safety. The manufacturer therefore declines any and every responsibility for any damage that may be caused by the use of non-original parts.

In addition:



- the user must take all the measures necessary to prevent unauthorised people gaining access to the machine
- the user must inform the manufacturer if faults or malfunctioning of the accident prevention systems are noticed, along with any presumed danger situation
- personnel must always use the personal protective equipment envisaged by legislation and follow the indications given in this manual

3 Technical description of the burner

3.1 Technical data

Model				RLAS 1000/EV (FGR prepared)			RLAS 1200/EV (FGR prepared)		
Output delivery ⁽¹⁾	High	Natural Gas	MBtu/hr ⁽²⁾	14.000	39.780	35.800*	20.500	43.000	38.700*
		#2	GPH	100	284	255*	146.4	307	276.4*
	Low	Natural Gas	MBtu/hr ⁽²⁾	-	-	-	4.300	-	-
		#2	GPH	-	-	-	30.7	-	-
Fuel				Oil #2 Natural gas					
Operation				Low - high or modulating					
Nozzles				1					
Standard applications				Boilers: water, steam, thermal oil					
Ambient temperature			°F	32 - 104 (0 - 40°C)					
Combustion air temperature			°F max	140 (60°C)					
Noise levels ⁽³⁾			dBA	80			90		

Tab. A

(1) Reference conditions: Ambient temperature 68 °F (20 °C) - Barometric pressure 394" wc - Altitude 329 ft.

(2) Related to G.C.V.

(3) Sound pressure measured in manufacturer's combustion laboratory, with burner operating on test boiler and at maximum rated output.

(*) Firing Rate for C-ETL Canadian Listing

3.2 Electrical data

Model		RLAS 1000/EV (FGR prepared)		RLAS 1200/EV (FGR prepared)	
Control circuit power supply	V/Ph/Hz	120/1/60			
Main power supply (+/- 10%)	V/Ph/Hz	460/3/60			
Electrical power consumption	W	25670		34235	
Electrical control circuit consumption	W max	1250		1250	
Total electrical consumption	W	26920		35485	
Electrical protection		NEMA 3			
Minimum Circuit Ampacity (MCA)	A	47		62	
Maximum rating of overcurrent protective device (MOP)	A	84		112	

Tab. B

3.3 Burner models designation

Model	RIELLO Code	RBNA Code	Voltage	Fan Motor Starting	Flame safeguard
RLAS 1000/EV (FGR prepared)	20141370	20164347	460/3/60	Inverter	Burner Mounted
RLAS 1000/EV (FGR prepared)		20164348	230/3/60	Inverter	Burner Mounted
RLAS 1200/EV (FGR prepared)	20141378	20164351	460/3/60	Inverter	Burner Mounted
RLAS 1200/EV (FGR prepared)		20164352	230/3/60	Inverter	Burner Mounted

Tab. C

3.4 Burner equipment

The burner is supplied complete with:

Thermal insulator screen	No. 1
Gas flange gasket	No. 1
Head looking screw replacement	No. 2
Gas flange to burner fixing - M16x67 Screw	No. 4
Gas flange to burner fixing - M16 Nut.	No. 4
Gas flange to burner fixing - M16 Washer	No. 4
Burner to boiler fixing - M20x70 Screw.	No. 4
Burner to boiler fixing - M20 Washer	No. 4
Burner to boiler fixing - M20 Nut.	No. 4
Installation, use & maintenance instruction	No. 1



It is recommended to tighten the screws of the gas flange with a tightening torque of:

- DN80: **40 Nm** ±10%;
- DN100: **50 Nm** ±10%;
- DN125: **60 Nm** ±10%.

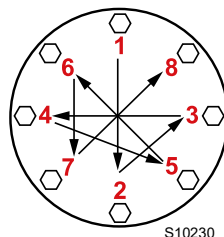

Tighten the nuts gradually (first to 30%, then to 60% up to 100%) according to the cross pattern shown in the figure.

3.5 Packaging

- The packaging of the burner (Fig. 1) rests on a wooden platform that is particularly suitable for lift trucks. The overall dimensions of the packaging are shown in the Tab. D.
- The weight of the burner complete with its packaging is shown in Tab. D.

inch	X	Y	Z	lbs
RLAS 1000/EV	94 31/64"	61 1/32"	62 63/64"	1190
RLAS 1200/EV	94 31/64"	61 1/32"	62 63/64"	1190

Tab. D

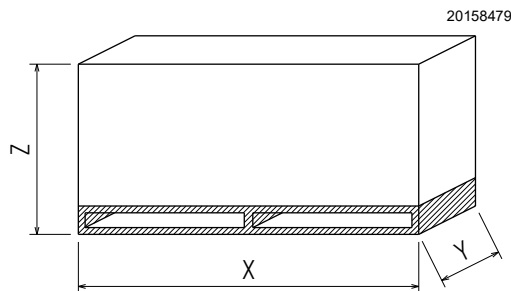

Fig. 1

3.6 Overall dimensions

The maximum dimensions of the burner are given in Fig. 2.

Bear in mind that inspection of the combustion head requires the burner to be opened by rotating the rear part on the hinge.

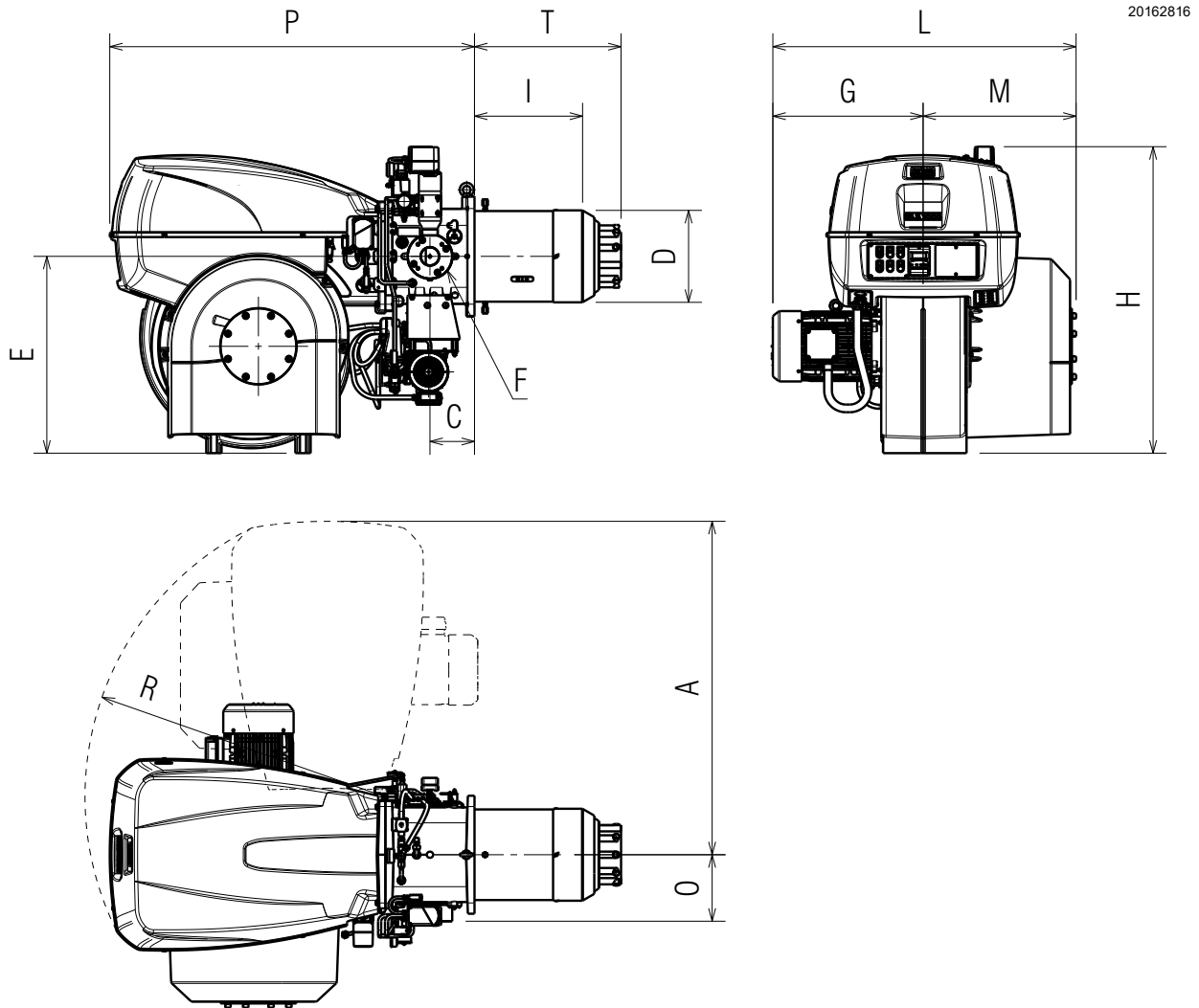

Fig. 2

Model		A	C	D	E	F	G	H	I	L	M	O	P	R	T
1000	[mm]	1500	200	413	884	ASME 150lb	674	1375	485	1360	686	299	1640	1350	658
	[inch]	59 1/16	7 7/8	16 17/64	34 51/64	Ø 3"	26 17/32	59 9/64	19 3/32	53 35/64	27 1/64	11 49/64	64 9/16	53 5/32	25 29/32
1200	[mm]	1500	200	456	884	ASME 150lb	774	1375	464	1460	686	299	1640	1350	658
	[inch]	59 1/16	7 7/8	17 61/64	34 51/64	Ø 3"	30 15/32	59 9/64	18 17/64	57 31/64	27 1/64	11 49/64	64 9/16	53 5/32	25 29/32

Tab. E

3.7 Burner capacity

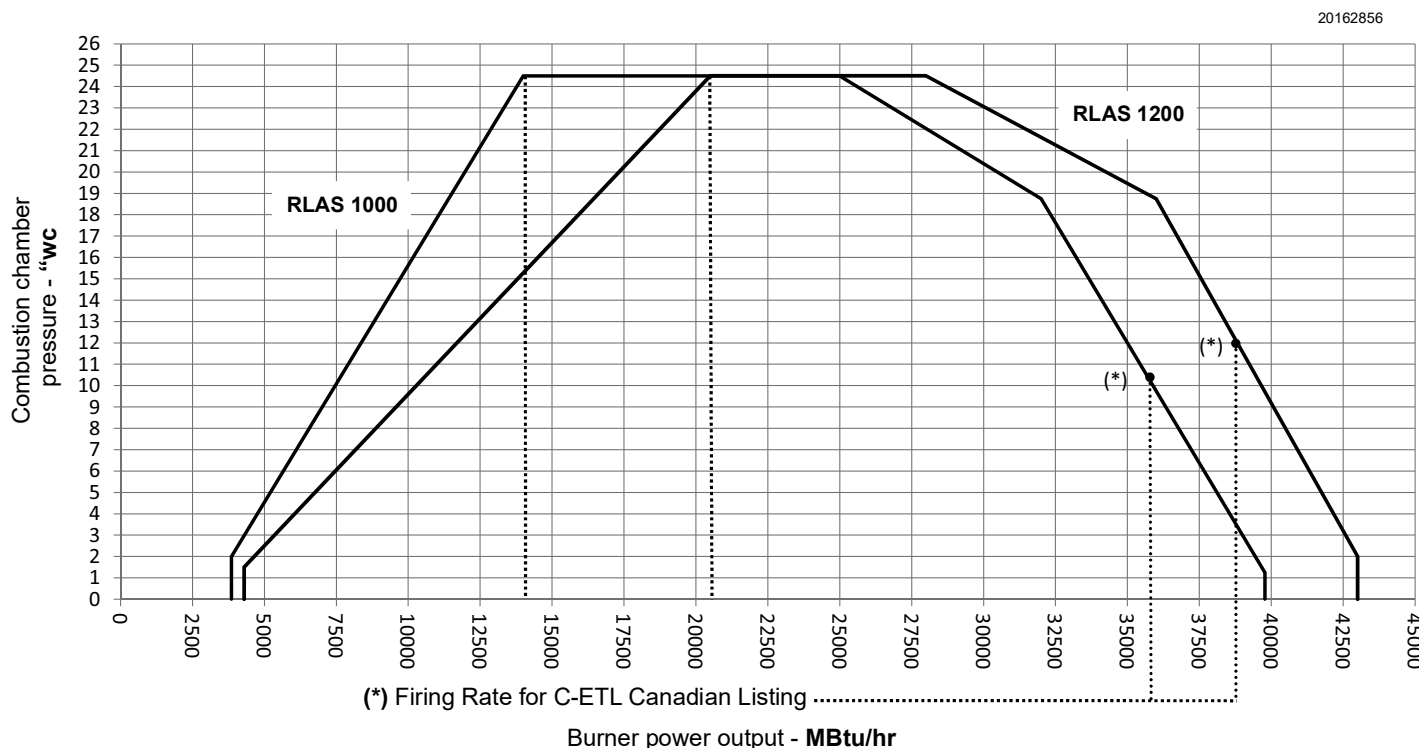

Fig. 3

3.7.1 Procedure to refer burner operating condition at an altitude and/or at a combustion supporter air temperature different to the standard values (328 ft above sea level, 68 °F).

Altitude		AIR TEMPERATURE											
ft a.s.l.	m a.s.l.	bar. press. "w.c.	bar. press. mbar	0 32	5 41	10 50	15 59	20 68	25 77	30 86	40 104	°C	°F
0	0	399	1013.00	1.087	1.068	1.049	1.031	1.013	0.996	0.980	0.948		
328	100	394	1000.00	1.073	1.054	1.035	1.017	1.000	0.983	0.967	0.936		
1.000	305	385	977.40	1.049	1.030	1.012	0.994	0.977	0.961	0.945	0.915		
2.000	610	371	942.80	1.012	0.994	0.976	0.959	0.943	0.927	0.912	0.883		
3.000	915	358	908.20	0.975	0.957	0.940	0.924	0.908	0.893	0.878	0.850		
4.000	1.220	345	875.80	0.940	0.923	0.907	0.891	0.876	0.861	0.847	0.820		
5.000	1.525	332	843.50	0.905	0.889	0.873	0.858	0.844	0.829	0.816	0.790		
6.000	1.830	320	811.85	0.871	0.856	0.841	0.826	0.812	0.798	0.785	0.760		
7.000	2.135	307	779.80	0.837	0.822	0.807	0.793	0.780	0.767	0.754	0.730		
8.000	2.440	294	747.80	0.803	0.788	0.774	0.761	0.748	0.735	0.723	0.700		

Tab. F

F - correction factor of discharge head and delivery in relation to temperature and altitude.

Reference conditions:

- Air temperature 68 °F (20 °C)
- Barometric pressure 394 "w.c. (1000 mbar)
- Altitude 328 ft a.s.l. (100 m a.s.l.)

Example

Using the , for an altitude of 3,000 ft and an air temperature of 68 °F, an **F** factor value is obtained equal to 0.908; if the capacity at the boiler furnace is $Q_{foc} = 4,500$ Mbtu/h, the correct output will be equal to:

$$Q_{burner} = Q_{foc} / F = 4,500 / 0.908 = 4,956 \text{ Mbtu/h}$$

3.8 Minimum furnace dimensions

The firing rate was obtained in special test boilers.

Example:

Fig. 4 indicates the diameter and length of the test combustion chamber.

Output 26510 Mbtu/hr: - diameter 47.7 inch - length 20 ft.

D9084

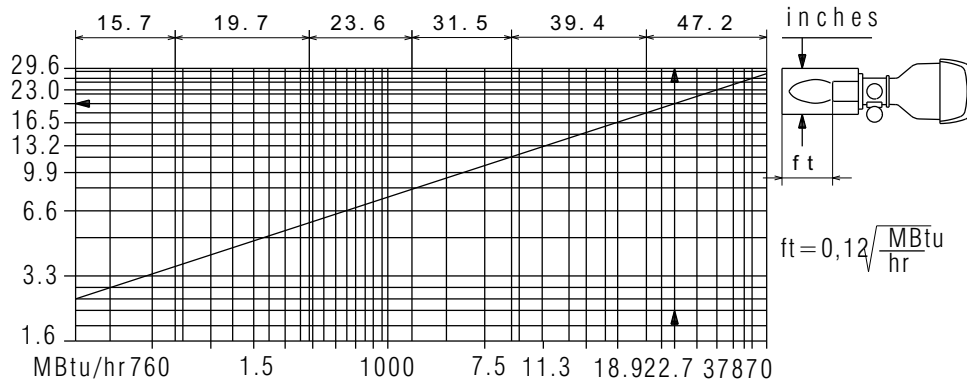

Fig. 4

3.9 Burner components

20147279

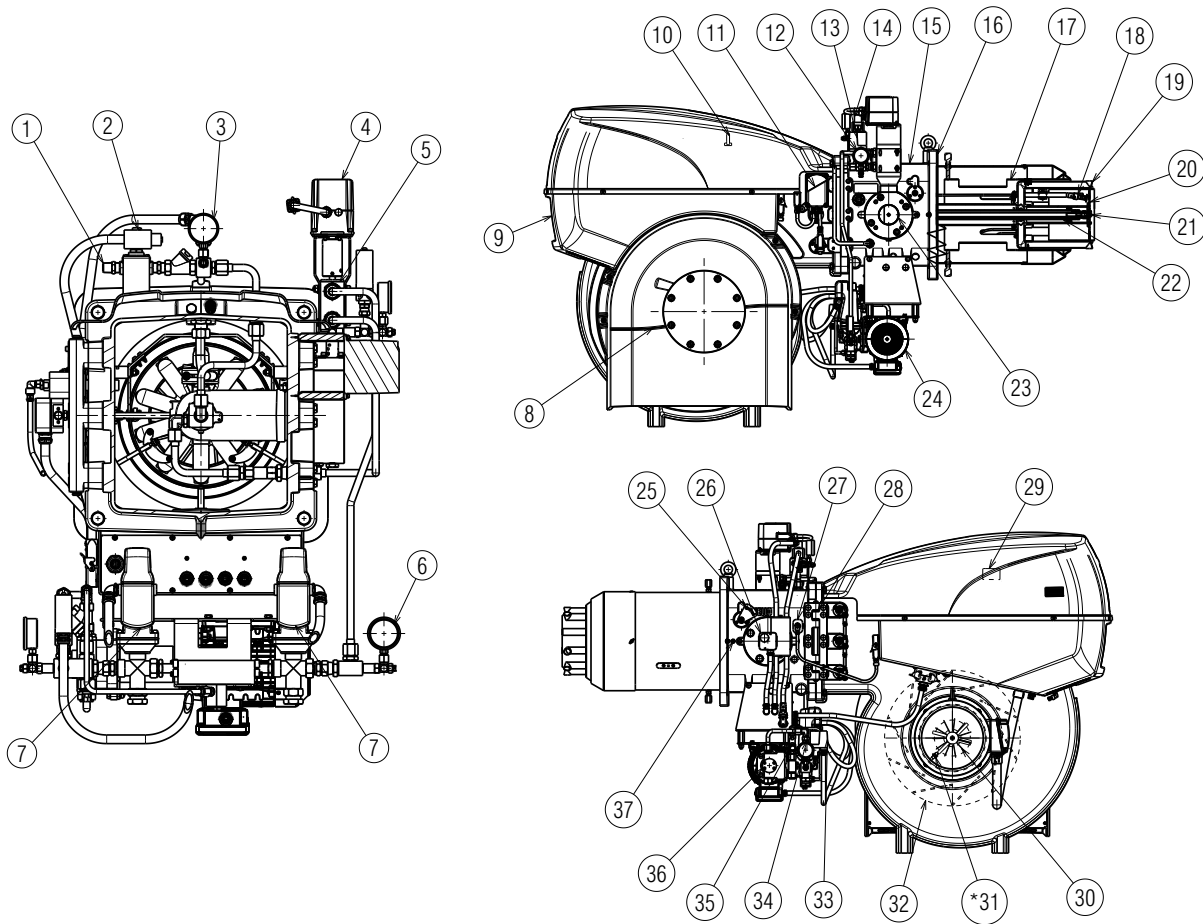

Fig. 5

- | | |
|--|---|
| 1 Compressed air valve | 25 Lever for movement of combustion head |
| 2 Air solenoid valve | 26 Max gas pressure switch with pressure test point |
| 3 Air inlet pressure gauge | 27 QRI flame detector |
| 4 Oil modulator and gas butterfly valve servomotor | 28 Hinge for opening burner |
| 5 Oil modulator | 29 Air pressure switch (diff.operating type) |
| 6 Nozzle delivery pressure gauge | 30 Fan motor |
| 7 Oil shut off VOG valve | 31 Speed sensor (*only EV version) |
| 8 Air inlet to fan | 32 Fan |
| 9 Electric panel board - cover | 33 Min oil pressure switch |
| 10 Lifting eyebolts | 34 Strainer |
| 11 Air gate valve servomotor | 35 Check valve |
| 12 Nozzle return pressure gauge | 36 Pump |
| 13 Max oil pressure switch | 37 Air pressure test point |
| 14 Air pressure switch | |
| 15 Manifold | |
| 16 Thermal insulation screen for securing burner to boiler | |
| 17 Shutter | |
| 18 Ignition pilot | |
| 19 Combustion head | |
| 20 Flame stability disk | |
| 21 Nozzle | |
| 22 Atomizing lance DN40 | |
| 23 Gas train flange | |
| 24 Pump motor | |

3.10 Panel board description

20164636

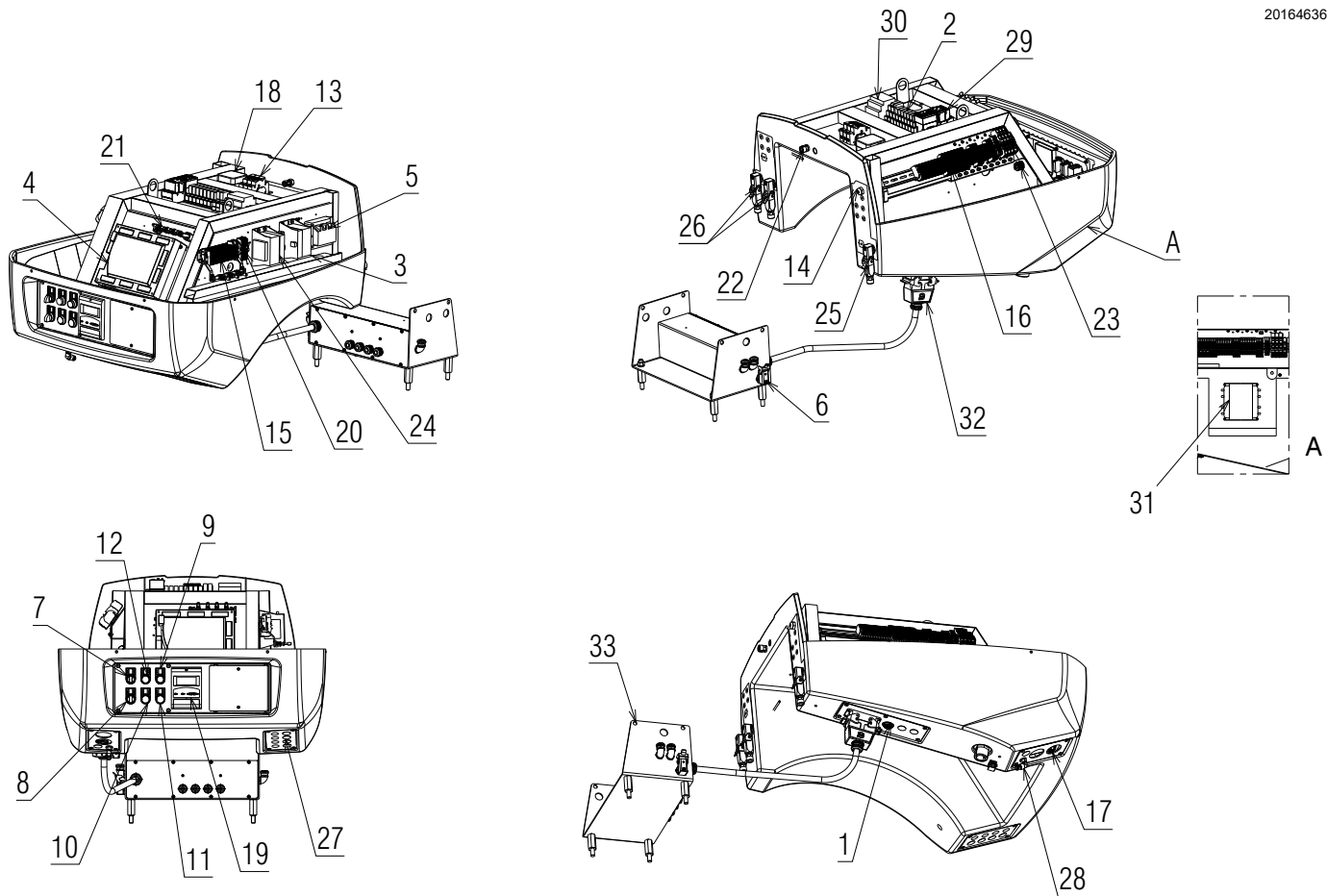

Fig. 6

- 1 Horn
- 2 Relays
- 3 Flame control transformer "T1"
- 4 Flame control for checking flame and air/fuel ratio
- 5 Ignition transformer "TA"
- 6 Plug/socket for maximum gas pressure switch
- 7 "OFF - LOCAL - REMOTE" switch
- 8 "OIL-EXT-GAS" switch
- 9 "ALARM SILENCE" button
- 10 "POWER ON" signal
- 11 "CALL FOR HEAT" signal
- 12 "Burner lock-out and reset" push button
- 13 Auxiliary fuse
- 14 Electric joint for air pressure switch pipe
- 15 "X2" terminal strip
- 16 "X1" burner terminal board
- 17 Holes for cables grommets for electrical wirings, accessories and power supply (to be carried out by the installer)
- 18 Low air pressure switch
- 19 Operator panel with LCD display
- 20 "XAUX" terminal strip
- 21 Bracket for shielded cables
Warning: used only to avoid a break in the cable's shielding, hence do not overtighten.
- 22 Electric joint for ignition cable
- 23 Speed sensor terminal strip "X70"
- 24 Additional transformer

- 25 Plug/socket for flame sensor
- 26 Plug/socket for air servomotor
- 27 Optional hole
- 28 Electric joint for speed sensor
- 29 Pump motor contactor and thermal relay
- 30 Touch screen display (available as kit)
- 31 Step-down transformer (available)
- 32 Plug/socket for pump motor group
- 33 Oil valve and motor pump electrical group

A type of burner failure may occur:

► **Flame safeguard lock-out**

If the flame safeguard alarm 12)(Fig. 6) lights up, it indicates that the burner is in lock-out. To reset, press the reset push-button.



The connection of the inverter and O₂ kits must be carried out by the client / installer following the instructions (electrical drawing) provided with the burner and the kits.

3.11 AZL display...

Warnings



To avoid accidents, material or environmental damage, observe the following instructions!

The AZL... display is a safety device! Avoid opening or modifying it, or forcing its operation. Riello S.p.A. cannot assume any responsibility for damage resulting from unauthorised interventions!

The electronic cam is operated and programmed through the AZL5 interface... or with the aid of a PC.

The AZL5 has a backlit LCD display with clear reading of the menu text and diagnostics.

The Modbus function of the AZL display integrates the electronic cam LMV5 and through data management allows the diagnostic of the burner.

The display shows the operating status, the types of errors and lockouts. Used to parametrize and monitor data.



Fig. 7

Technical data

Operating voltage	AC 24 V - 15% / +10%
Power consumption	< 5W (typical)
Protection level of the container	
– Rear	IP00 according to IEC 529
– Front	IP54 according to IEC 529 (if installed)
Safety class	I with parts II and III according to DIN EN 60730-1
Battery - Manufacturer:	Type reference:
VARTA	CR 2430 (LF-1/2 W)
DURACELL	DL 2430
SANYO ELECTRIC, Osaka/ Japan	CR 2430 (LF-1/2 W)
RENATA AG, Itingen/CH	CR 2430

Tab. G

3.12 Flame control (LMV52...)

Warnings



To avoid accidents, material or environmental damage, observe the following instructions!

The flame control is a safety device! Avoid opening or modifying it, or forcing its operation. Riello S.p.A. cannot assume any responsibility for damage resulting from unauthorised interventions!

Risk of explosion!

An incorrect configuration can provoke fuel overcharging, with the consequential risk of explosion! Operators must be aware that incorrect settings made on the AZL5... display and operating unit and incorrect settings of the fuel and / or air actuator positions can lead to dangerous burner operating conditions.

- All interventions (assembly and installation operations, assistance, etc.) must be carried out by qualified personnel.
- Before modifying the wiring in the flame control connection area, fully disconnect the system from the power supply (omnipolar separation). Check the system is not powered and cannot be accidentally reconnected. Failure to do this will lead to the risk of electrocution.
- Protection against electrocution from the flame control and all connected electric components is obtained with correct assembly.
- Before any intervention (assembly and installation operations, assistance, etc.), ensure the wiring is in order and that the parameters are correctly set, then make the safety checks.
- Falls and collisions can negatively affect the safety functions. In this case, the flame control must not be operated, even if it displays no evident damage.
- In programming mode, the position check of actuators and VSD (checking electronic fuel / air ratio control) is different from the check during automatic operation. As for automatic operation, the actuators are guided together to the positions requested and, if an actuator does not reach the position requested, adjustments are made until the position is actually reached. However, in contrast to automatic operation, there are no time limits to these corrective actions. The other actuators maintain their positions until all actuators have reached the positions currently required. This is absolutely important to set the fuel / air ratio control system. During the time the fuel / air ratio curves are being programmed, the person making the plant settings must continuously monitor the quality of the combustion process (e.g. by means of a flue gas analyser). Also, if combustion levels are poor, or in the event of dangerous situations, the commissioning engineer must take appropriate action (e.g. switching off manually).

To ensure the safety and reliability of the flame control, the following instructions must also be followed:

- avoid conditions that can favour the development of condensate and humidity. Otherwise, before switching on again, make sure that the entire flame control is perfectly dry!
- Static charges must be avoided since they can damage the flame control's electronic components when touched.



D9301

Fig. 8

Mechanical structure

The flame control is a system to check the burners, based on a microprocessor and equipped with components to adjust and monitor medium and large capacity forced draught burners.

The base flame control incorporates the following components:

- Burner control with gas valve proving system
- Electronic fuel / air ratio control with a maximum of 6 actuators
- Optional PID temperature / pressure controller (load controller)
- Optional VSD module Mechanical design

Electrical connection of ionization probe and flame detector

It is important to achieve practically disturbance- and loss-free signal transmission:

- Never run the detector cables together with other cables:
 - Line capacitance reduces the magnitude of the flame signal.
 - Use a separate cable.
- Observe the permissible cable lengths.

Technical data

LMV52... basic unit	Mains voltage	AC 120 V -15 % / +10 %
	Mains frequency	50 / 60 Hz ±6 %
	Power consumption	< 30 W (typically)
	Safety class	I, with parts according to II and III to DIN EN 60730-1
Terminal loading 'Inputs'	Unit fuse F1 (internally)	6.3 AT
	Perm. mains primary fuse (externally)	Max. 16 AT
	Undervoltage	
	• Safety shut-down from operating position at mains voltage	< AC 96 V
	• Restart on rise in mains voltage	> AC 100 V
	Oil pump / magnetic clutch (nominal voltage)	
	• Nominal current	1.6A
	• Power factor	cosφ > 0.4
	Air pressure switch test valve (nominal voltage)	
	• Nominal current	0.5A
• Power factor	cosφ > 0.4	
Terminal loading 'Outputs'	Total contact loading:	
	• Mains voltage	AC 120 V -15 % / +10 %
	• Input current of unit (safety loop) total load on contacts resulting from:	Max. 5 A
	- Fan motor contactor	
	- Ignition transformer	
	- Valve	
	- Oil pump / magnetic clutch	
	Single contact loading:	
	Fan motor contactor (nominal voltage)	
	• Nominal current	1A
	• Power factor	cosφ > 0.4
	Alarm output (nominal voltage)	
	• Nominal current	1 A
	• Power factor	cosφ > 0.4
	Ignition transformer (nominal voltage)	
	• Nominal current	1.6 A
	• Power factor	cosφ > 0.2
	Fuel valve gas (nominal voltage)	
• Nominal current	1.6 A	
• Power factor	cosφ > 0.4	
Fuel valve oil (nominal voltage)		
• Nominal current	1.6 A	
• Power factor	cosφ > 0.4	
Cable lengths	Main line	Max. 100 m (100 pF/m)
Environmental conditions	Operation	DIN EN 60721-3-3
	Climatic conditions	Class 3K3
	Mechanical conditions	Class 3M3
	Temperature range	-20...+60 °C
	Humidity	< 95 % r.h.

Tab. H

Operation sequence of the burner

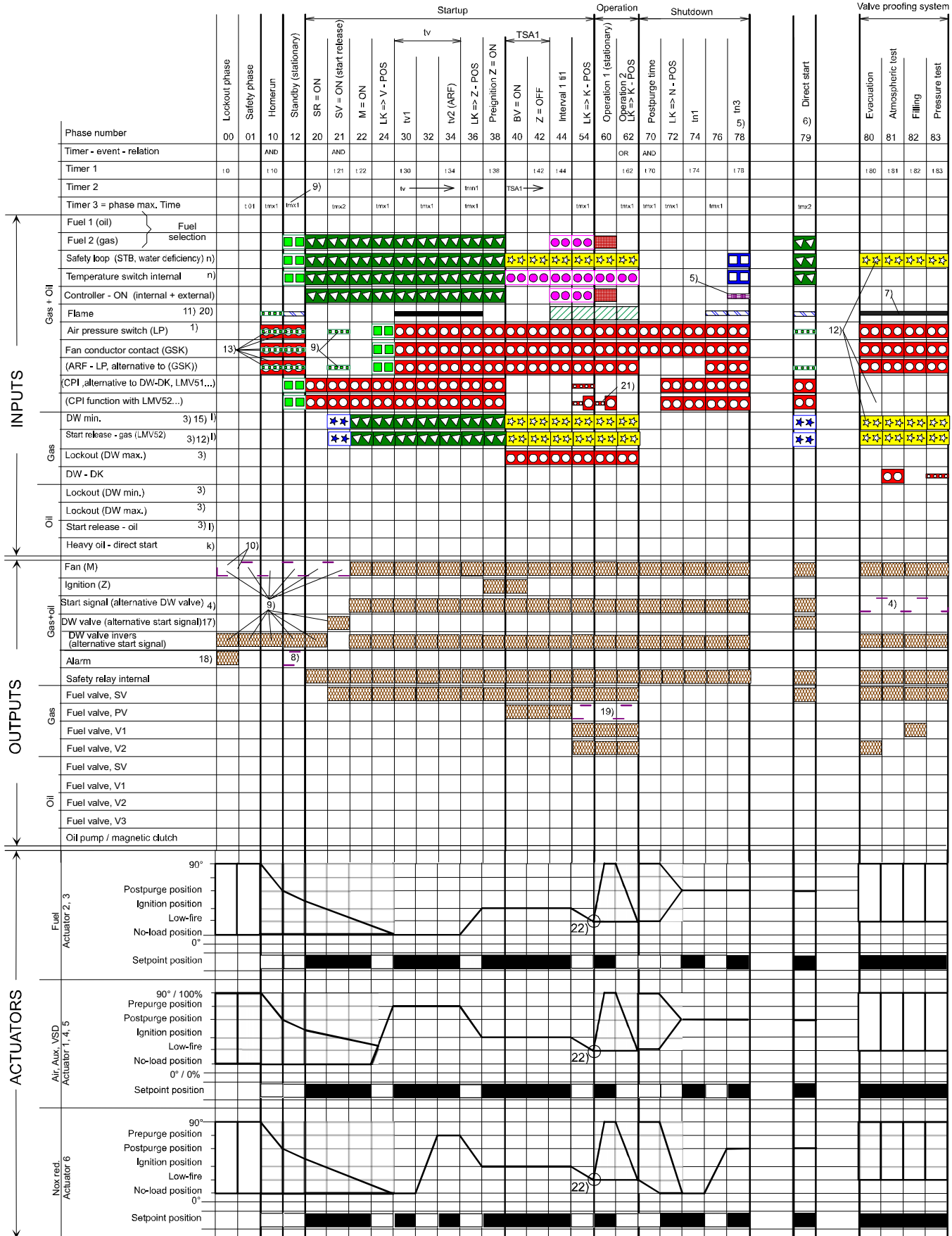

D9507

Fig. 9

Key to the sequence diagrams:

Depending on the parameter, valve proving takes place:
 between phase 62 and phase 70 or/and
 between phase 30 and phase 32.

Signal ON	Signal OFF	Next phase
		01 $\begin{cases} \rightarrow 00, \text{Rep} = 0 \\ \rightarrow 12, \text{Rep} > 0 \end{cases}$ Parameter direct start
		Checking with controller on Deviation \rightarrow 10 No Rep. decrement
		10
		70
		Without VP70 with VP80
		62
		Stop, up to Ph – max. time \rightarrow 01
		Stop, up to Ph – max. time \rightarrow 10
		01 $\begin{cases} \rightarrow 00, \text{Rep} = 0 \\ \rightarrow 12, \text{Rep} > 0 \end{cases}$ 0-3 s.
		01 $\begin{cases} \rightarrow 00, \text{Rep} = 0 \\ \rightarrow 12, \text{Rep} > 0 \end{cases}$ 0-30 s.
		01 $\begin{cases} \rightarrow 00, \text{Rep} = 0 \\ \rightarrow 12, \text{Rep} > 0 \end{cases}$ 0-3 s.
		Param. $\begin{cases} \rightarrow 79 \\ \rightarrow 10 \end{cases}$
		Input: don't care
		Output: OFF
		Output: ON

Assignment of times:

t0	Postpurge lockout position
t01	Max. time safety phase
t10	Min. time home run
t21	Min. time start release
t22	Fan runup time
t30	Prepurge time part 1
t34	Prepurge time part 3
t36	Min. ON time oil pump
t38	Preignition time gas / oil
t42	Preignition time OFF
t44	Interval 1 gas / oil
t62	Max. time low-fire
t70	Afterburn time
t74	Postpurge time 1 gas / oil (tn1)
t78	Postpurge time 3 gas / oil (tn3)
t80	Valve proving evacuate time
t81	Leakage test time atmospheric pressure
t82	Leakage test filling test
t83	Leakage test time gas pressure
tmn1	Min. time extraneous light test (5 s.) after skip over of prepurge
tmx1	Max. damper running time
tmx2	Max. time startup release
tmx3	Max. time circulation heavy oil
tn	Postpurge time
TSA1	Safety time 1
TSA2	Safety time 2
tv	Prepurge time gas / oil

Key to the sequence diagrams:

- 1) Parameter: With / without pressure switch
- 2) Parameter: Short / long preignition time for oil only Short / long oil pump – ON – time
- 3) Delayed shutdown within TSA1 + TSA2
- 4) Parameter: Output as startup signal / pressure switch relief valve
- 5) Parameter: Normal / direct startup
 Normal startup → sequential phase = 10
 Direct startup → sequential phase = 79
 (when R = ON)
- 6) Sequential phase = 24
- 7) Only with valve proving during startup
- 8) Parameter: With / without alarm on prevention of startup
- 9) Parameter: With continuous purging the shown output signals are inverted
- 10) Fan controlled as before
 Running time when LOCK OUT = T_FanLockout LF
- 11) Parameter: With / without extraneous light test in STANDBY
- 12) With valve proving during startup phase 10
- 13) Parameter: Normal / continuous purging
 Normal purging: Checking for off in 10, stop to Ph-max time → 01
 Continuous purging: Checking for on in 10 and 12, Stop up to phase-max time → 01
- 14) Parameter: "OilPressureMin", "akt_from_ts" → no check before TSA1 (LO, HO) or TSA2 (LOgp, HOgp)
- 15) Parameter: "GasPressureMin", "deakt_xOGP" → pressure switch-min can be deactivated for oil programs with gas pilot
- 16) Parameter: "OilPumpCoupling", "direct_coupl" → shutoff valve oil has to be connected to output "Oil pump / magnetic clutch". Output is active when fan is on and for another 15 s after fan is switched off
- 17) Parameter: "Start / pressure switch valve", "PS_Reli_Inv" → Output pressure switch valve will be logically inverted
- 18) Parameter: "Alarm act / deact", "deactivated" → The alarm output can temporarily be deactivated (for current error only)
- 19) Parameter: Only with LMV52...: Continuous pilot gas / oil: Activated → Pilot valve is also activated in operation
- 20) Parameter: Only with LMV52...: Extraneous light, pilot phase, operating phase gas / oil → Separate flame supervision possible
- 21) Parameter: Only with LMV52...: pressure switch valve proving / CPI or StartReleaseGas → Parameter-dependent ON / OFF test
 CPI Gas: OFF test for gas trains only
 CPI Oil: OFF test for oil trains only
 CPI Gas+Oil: OFF test for gas and oil trains
- 22) Parameter: After LMV52... software version 04.50 and AZL5... software version 04.40, dependent on parameter *StartPktOperation*



Permissible positioning range



In Standby: actuator can travel within the permissible positioning range, but is always driven to the home position. Must be in the home position before changing the phase.

0°	Position as supplied (0°)
90°	Actuator fully open (90°)
AGR	Fuel gas recirculation
CPI	Closed position indication
DP	Pressure tester
PS-VP	Pressure switch – valve proving
FCC	Fan contactor contact
LF	Air damper
APS	Air pressure switch
N	Postpurging
SR	Safety relay
SLT	Safety limit thermostat
TL	Temperature limiter

Repetition counter:

- k) Heavy oil
- l) Restricted startup behavior
- n) Restricted safety loop

3.13 Servomotor (SQM48.4....)

Important notes



To avoid accidents, material or environmental damage, observe the following instructions!
Avoid opening, modifying or forcing the actuators.

- All interventions (assembly and installation operations, assistance, etc.) must be carried out by qualified personnel.
- Before modifying the wiring in the SQM4... system connection area, fully disconnect the burner control device from the power supply (omnipolar separation).
- To avoid the risk of electrocution, protect the connection terminals in a suitable manner and correctly fix the cover.
- Check the wiring is in order.
- Falls and collisions can negatively affect the safety functions. In this case, the unit must not be operated, even if it displays no evident damage.

Assembly notes

- Check the relevant national safety standards are respected.
- The connection between the actuator command shaft and the control element must be rigid, without any mechanical play.
- To avoid an excessive load on the bearings due to rigid hubs, the use of compensation clutches without any mechanical play is recommended (e.g. metal bellows-type clutches).

Installation notes

- Arrange the HV ignition cables separately, as far as possible from the flame control and the other cables.
- To avoid the risk of electrocution, make sure that the 230V AC section of the SQM4... unit is fully separated from the functional low-voltage section.
- The static torque is reduced when the electrical supply of the actuator is switched off.
- The housing cover may only be removed for short periods of time for wiring or when making the addressing. In similar cases, make sure that dust or dirt does not penetrate inside the actuator.
- The actuator comprises a PCB with ESD-sensitive components.
- The top side of the board carries a cover which affords protection against direct contact. This protective cover must not be removed! The underside side of the board must not be touched.



During the maintenance or replacement of the actuators, be careful not to invert the connectors.

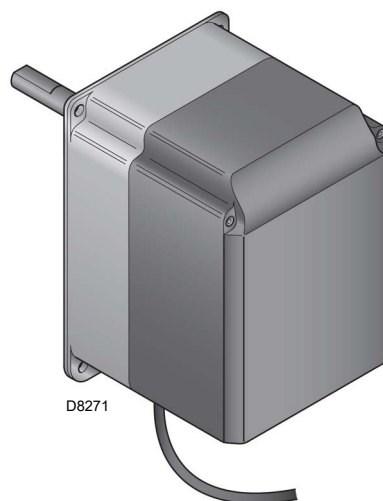

Fig. 10

Technical data

Operating voltage	AC 2 x 12V via bus cable from the base unit or via a separate transformer
Safety class	extra low-voltage with safe isolation from mains voltage
Power absorption	26...34 VA
Protection level	to EN 60 529, IP 54, provided adequate cable entries are used
Cable connection	RAST3,5 connectors
Rotation direction	- Anticlockwise (standard) - Clockwise (inverted rotation)
Rated torque (max.)	20 Nm
Static torque (max.)	20 Nm
Operation time (min.) for 90°	30 s.
Weight	approx. 1.6 kg
Environmental conditions:	
Operation	DIN EN 60 721-3-3
Climatic conditions	Class 3K3
Mechanical conditions	Class 3M3
Temperature range	-20...+60 °C
Humidity	< 95% RH

Tab. I

4 Installation

4.1 Notes on safety for the installation

After carefully cleaning all around the area where the burner will be installed, and arranging the correct lighting of the environment, proceed with the installation operations.



All the installation, maintenance and disassembly operations must be carried out with the electricity supply disconnected.



The installation of the burner must be carried out by qualified personnel, as indicated in this manual and in compliance with the standards and regulations of the laws in force.



Combustion air inside the boiler must be free from hazardous mixes (e.g.: chloride, fluoride, halogen); if present, it is highly recommended to carry out cleaning and maintenance more frequently.

4.2 Handling

The burner packaging includes a wooden platform, it is therefore possible to move the burner (still packaged) with a transpallet truck or fork lift truck.



The handling operations for the burner can be highly dangerous if not carried out with the greatest attention: keep any unauthorised people at a distance; check the integrity and suitability of the available means of handling.

Check also that the area in which you are working is empty and that there is an adequate escape area (i.e. a free, safe area to which you can quickly move if the burner should fall).

When handling, keep the load at not more than 20-25cm from the ground.



After positioning the burner near the installation point, correctly dispose of all residual packaging, separating the various types of material.



Before proceeding with the installation operations, carefully clean all around the area where the burner will be installed.

4.3 Preliminary checks

Checking the consignment



After removing all the packaging, check the integrity of the contents. In the event of doubt, do not use the burner; contact the supplier.



The output of the burner must be within the boiler's firing rate.



The packaging elements (wooden cage or cardboard box, nails, clips, plastic bags, etc.) must not be abandoned as they are potential sources of danger and pollution; they should be collected and disposed of in the appropriate places.



A burner label that has been tampered with, removed or is missing, along with anything else that prevents the definite identification of the burner makes any installation or maintenance work difficult.

4.4 Operating position



- The burner is designed to operate only in positions 1 and 4 (Fig. 11).
- Installation 1 is preferable, as it is the only one that allows the maintenance operations as described in this manual.
- Installation 4 permits operation but make maintenance and inspection of the combustion head more difficult.



- Any other position could compromise the correct operation of the appliance.
- Installations 2, 3 and 5 are prohibited for safety reasons.

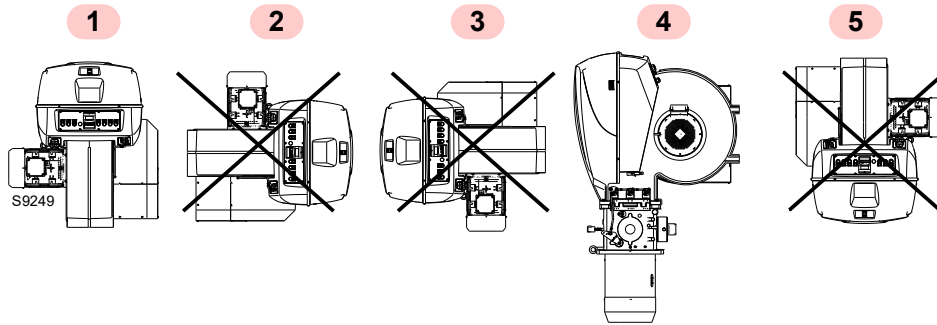

Fig. 11

4.5 Removing the shutter lockout screws



Remove the screws 1)-2) and nuts before fitting the burner onto the boiler (Fig. 13).
Replace them with screws 3) M12x16 supplied as standard.

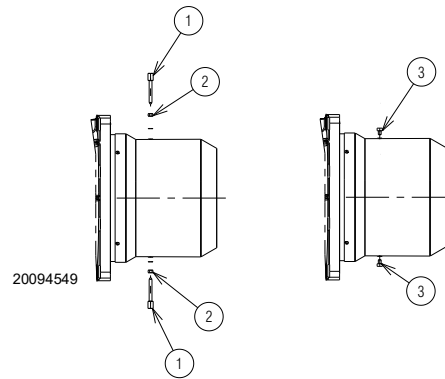

Fig. 12

4.6 Preparing the boiler

4.6.1 Boring the boiler plate

Pierce the closing plate of the combustion chamber, as in Fig. 12. The position of the threaded holes can be marked using the thermal insulation screen supplied with the burner.

4.6.2 Blast tube length

The length of the blast tube must be selected according to the indications provided by the manufacturer of the boiler, and in any case it must be greater than the thickness of the boiler door complete with its fettling.

For boilers with front flue passes 7)(Fig. 14) or flame inversion chambers, protective fettling in refractory material 5) must be inserted between the boiler fettling 6) and the blast tube 4).

This protective fettling must not compromise the extraction of the blast tube.

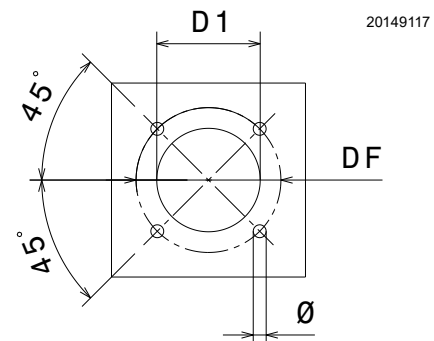

Fig. 13

inch	D1	DF	Ø
RLAS 1000/EV	16 ¹⁷ / ₆₄ "	23 ¹⁵ / ₁₆ "	M20
RLAS 1200/EV	17 ⁶¹ / ₆₄ "	23 ¹⁵ / ₁₆ "	M20

Tab. J

4.7 Securing the burner to the boiler



Prepare a suitable lifting system using the rings 3) after having removed the casing 1) unscrewing screws 2)(Fig. 14).



The seal between burner and boiler must be air-tight.

WARNING

- Insert the thermal protection supplied with the blast tube 4).
- Fit the entire burner onto the boiler hole, prepared previously, as in Fig. 14, and fasten with the screws supplied.

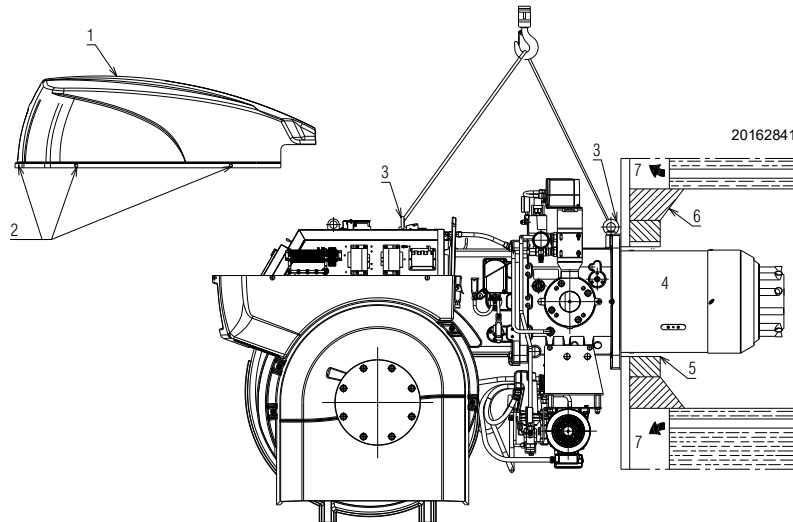

Fig. 14

4.8 Access to head internal part

In order to reach inside the combustion head (Fig. 15) proceed as follows:

- disconnect the derivation unit socket 1);
- disconnect the servomotor socket 2);
- unscrew the fixing screws 5) of the manifold;
- open the burner on hinge;
- open partially of about 5.90 inch
- disconnect the cable of pilot electrode 6);
- open the burner;
- release the ignition pilot fitting 7);

- disconnect the oil pipe 8) and the air pipe 9);
- unscrew the lockout screw 10) of oil/air lance 10);
- extract the oil/air lance from the combustion head 11);
- remove the combustion head 11) from the pipe coupling.

To close, repeat the procedure in reverse order.



Be careful as fuel may leak during this phase.

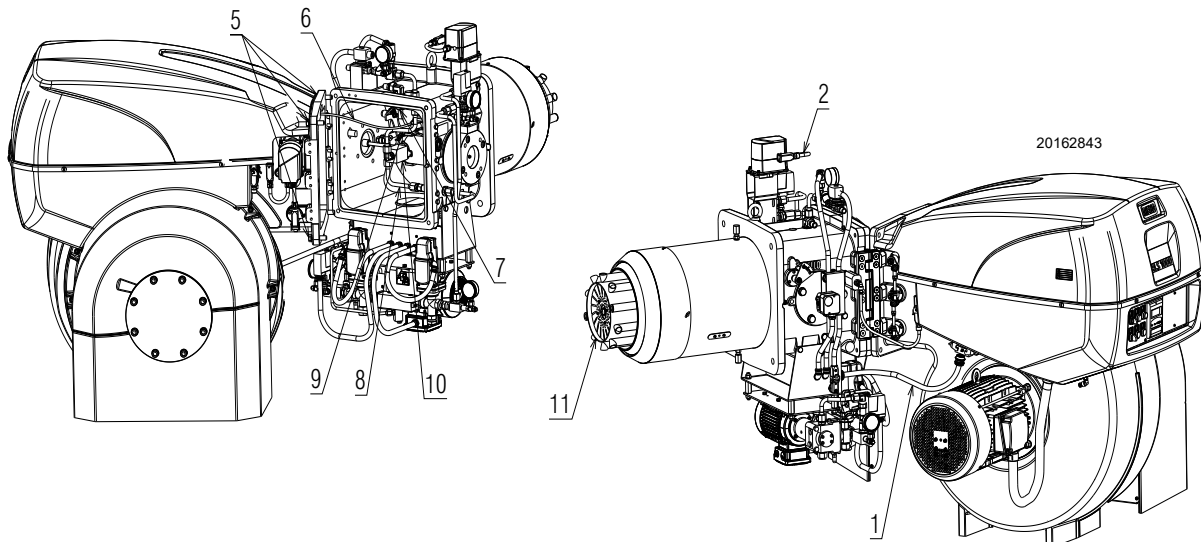

Fig. 15

4.9 Combustion head adjustment

Changing the position of the head movement lever 1)(Fig. 16), we can obtain different output firing rates (see Tab. K).

FIRING RATES (MBtu/hr)		HEAD POSITION
RLAS 1000/EV	RLAS 1200/EV	
14000	20500	5
19156	25000	6
24312	29500	7
29468	34000	8
34624	38500	9
39780	43000	10

Tab. K



The gas pipes leave the factory calibrated at notch 1. The adjustment shown in Fig. 17 allows the gas pipes to be positioned in the best way for the application on which the burner is installed (e.g. boilers with flame inversion chamber).

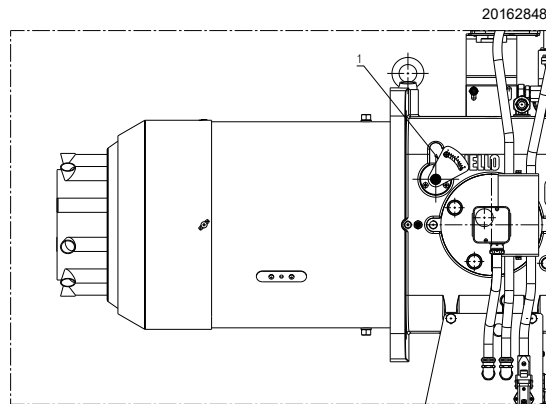

Fig. 16

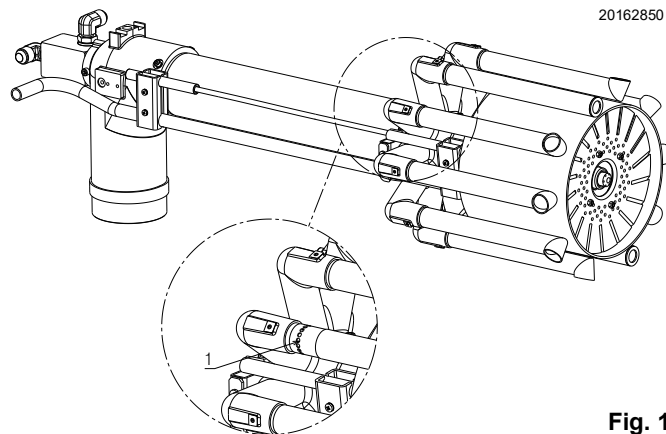

Fig. 17



Fig. 18

4.10 Electrode position



Place the electrode on the ignition pilot observing the dimensions specified in Fig. 19.

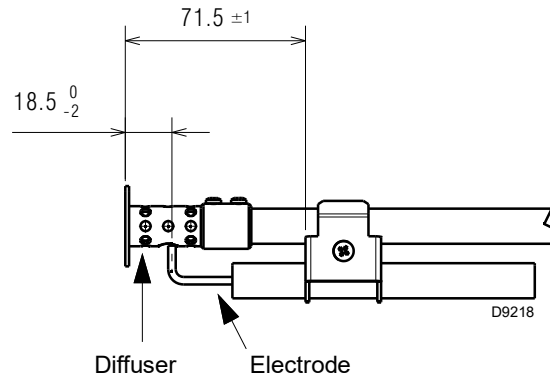

Fig. 19

4.11 Nozzle installation

The burner complies with the emission requirements of the EN 267 standard. In order to guarantee that emissions do not vary, recommended and/or alternative nozzles specified by Riello in the instruction and warning booklet should be used.



It is advisable to replace the nozzle once a year during periodical maintenance.

Fit the nozzle with a 27 mm key, passing from the centre opening of the flame stability disc.

Fit the nozzles with the fuel interception rod on the nozzle holder.



The use of nozzles other than those specified by Riello S.p.A. and inadequate regular maintenance may result into emission limits non-conforming to the values set forth by the regulations in force, and in extremely serious cases, into potential hazards to people and objects.

The manufacturing company shall not be liable for any such damage arising from nonobservance of the requirements contained in this manual.



- Do not use any sealing products such as gaskets, sealing compound, or tape.
- Be careful to avoid damaging the nozzle sealing seat.
- The nozzle must be screwed into place tightly but not to the maximum torque value provided by the wrench.

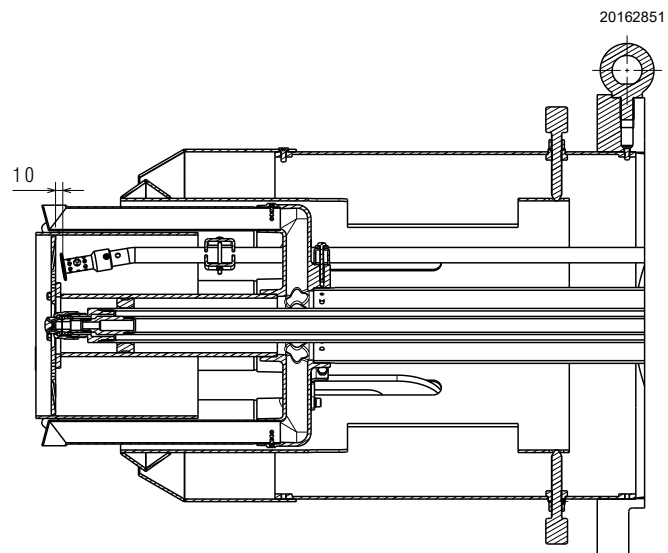

Fig. 20

4.11.1 Recommended nozzle

Fluidics type

- 24 Y 80° - 00 - 6
- 24 Y 80° - 0 - 6
- 24 Y 80° - 1 - 6
- 24 Y 80° - 2 - 6
- 24 Y 80° - 3 - 6
- 24 Y 80° - 4 - 6
- 24 Y 80° - 5 - 6

4.11.2 Air atomiser unit (assisted atomisation)

The Y-Jet atomiser unit has the following features:

- 1 Disc type 24-S (Fluidics)
- 2 Air/steam atomiser type 24-Y (Fluidics)
- 3 Capnut 24 (Fluidics)

The delivery range and pulverisation angles are given by the variants that are available for the element 2)(See the diagram Fig. 22).

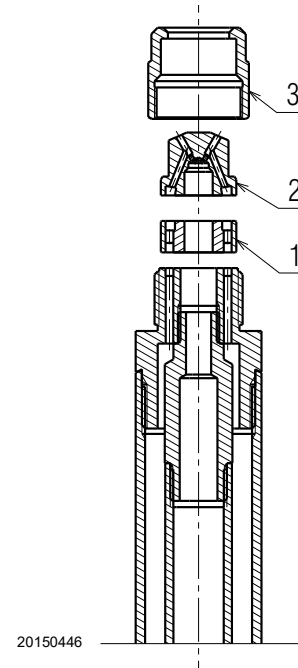

Fig. 21

Nozzle RLAS 1000-1200 (air pressure = 72.5 PSI) - 6 bores type

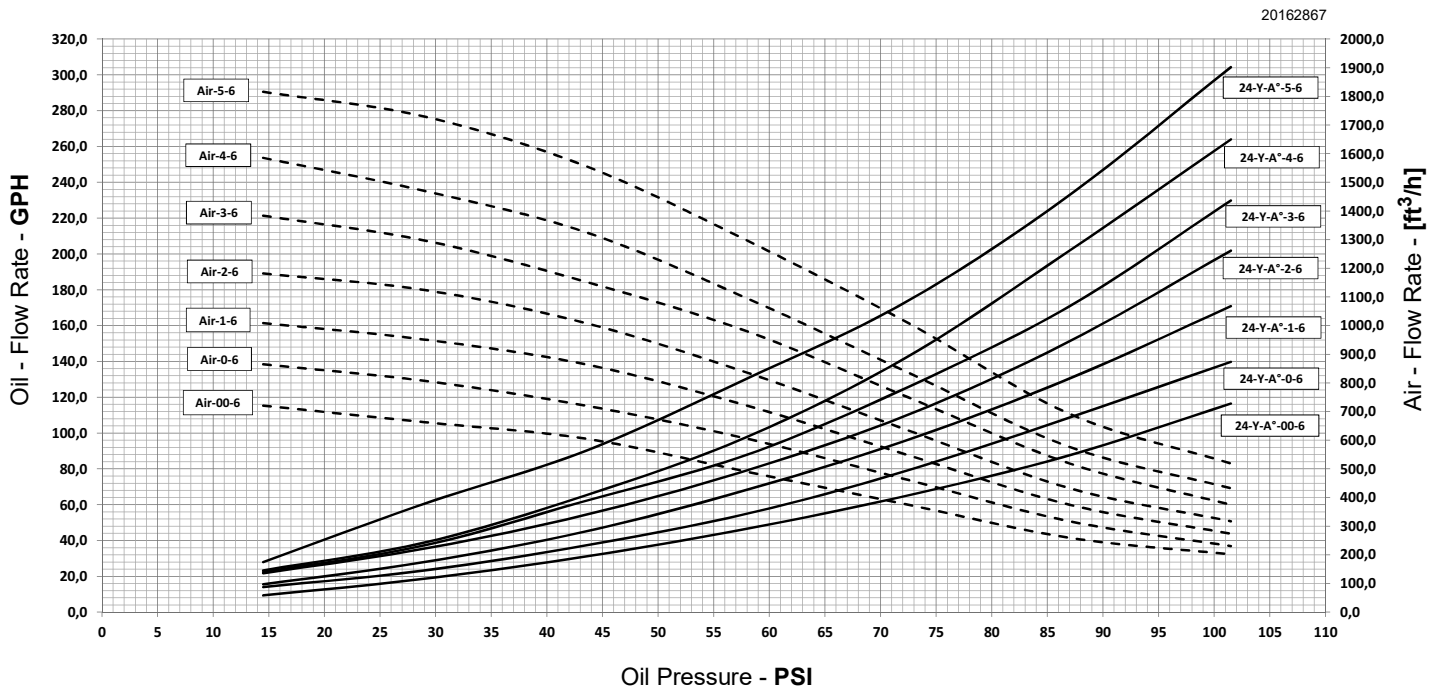

Fig. 22

4.12 Light oil supply



Explosion danger due to fuel leaks in the presence of a flammable source.

Precautions: avoid knocking, attrition, sparks and heat.

Make sure that the fuel interception tap is closed before performing any operation on the burner.



WARNING

The fuel supply line must be installed by qualified personnel, in compliance with current standards and laws.

4.12.1 Double-pipe circuit

The burner is equipped with a self-priming pump which is capable of feeding itself within the limits listed in the Tab. L.

The tank higher than the burner A

The distance "P" must not exceed 33 ft in order to avoid subjecting the pump's seal to excessive strain; the distance "V" must not exceed 4 meters in order to permit pump self-priming even when the tank is almost completely empty.

The tank lower than the burner B

Pump depression values higher than 0.45 bar (35 cm Hg) must not be exceeded because at higher levels gas is released from the fuel, the pump starts making noise and its working life-span decreases. It is good practice to ensure that the return and suction lines enter the burner from the same height; in this way it will be more improbable that the suction line fails to prime or stops priming.

4.12.2 The loop circuit

A loop circuit consists of a loop of piping departing from and returning to the tank with an auxiliary pump that circulates the fuel under pressure.

A branch connection from the loop goes to feed the burner.

This circuit is extremely useful whenever the burner pump does not succeed in self-priming because the tank distance and/or height difference are higher than the values listed in the Tab. L.

+/- H (ft)	L (ft)	
	Ø 1/2"	Ø 5/8"
+ 13	197	263
+ 10	164	230
+ 6.6	132	197
+ 4.8	115	181
+ 3.3	99	164
+ 1.6	82	148
0	66	132
- 1.6	59	115
- 3.3	49	99
- 4.8	43	82
- 6.6	33	66
- 10	16	33
- 13	-	20

Tab. L

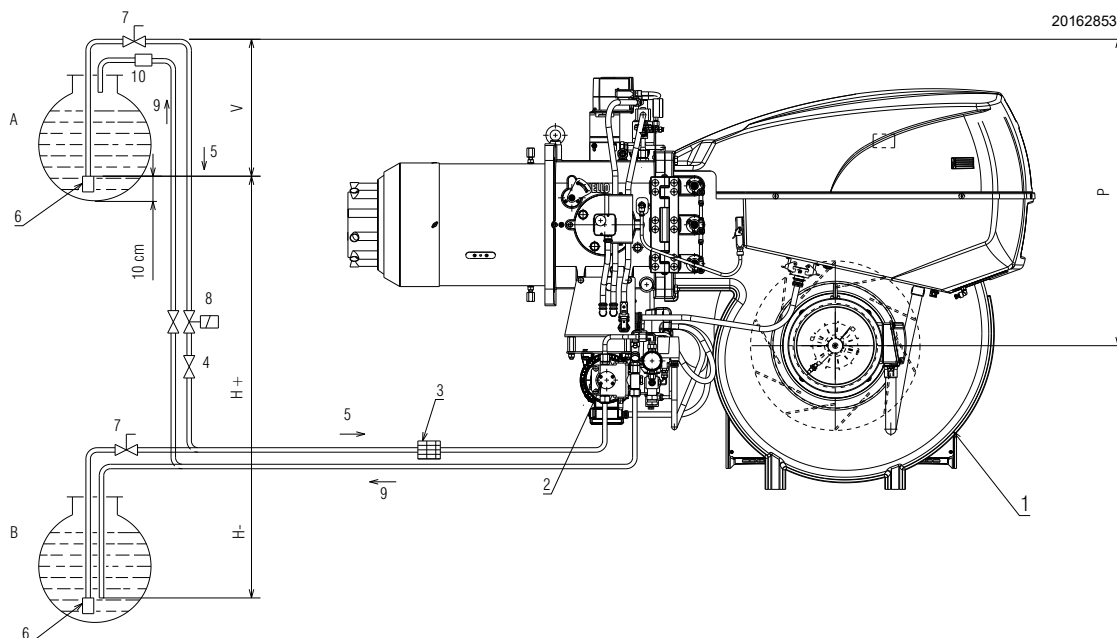

Fig. 23

Key (Fig. 23)

- 1 Burner
- 2 Pump
- 3 Filter
- 4 Manual on/off valve
- 5 Suction line
- 6 Foot valve
- 7 Rapid closing manual valve remote controlled (only Italy)
- 8 On/off solenoid valve (only Italy). See layout of electric panel board. Electrical connections set by installer (SV)
- 9 Return line
- 10 Check valve (only Italy)
- H Pump/foot valve height difference
- L Piping length
- Ø Inside pipe diameter

4.12.3 Hydraulic connections



Make sure that the flexible hoses to the pump supply and return line are installed correctly.



Follow the instructions below:

- tighten the flexible hoses with the supplied gas-kets.
- Take care that the hoses are not stretched or twisted during installation.
- Place the pipes so that they are not crushed or are in contact with hot parts of the boiler and so it is possible to open the burner.
- Finally, connect the other end of the flexible hoses to the suction and return pipes.

4.12.4 Hydraulic circuit layout

Key (Fig. 24)

- 1 Pump suction
- 2 Pump pressure regulator
- 3 Filter
- 4 Oil pressure gauge
- 5 Min. Oil pressure switch
- 6 Safety valve
- 7 Discharge valve
- 8 Control valve
- 9 Oil modulator
- 10 Air solenoid valve
- 11 Air pressure switch
- 12 Air pressure gauge
- 13 Nozzle
- 14 Max oil pressure switch
- P Pressure gauge connection
- V Vacuumeter connection

OPERATION

Pre-purging phase: valves 6) closed.

Ignition and operation phase: valves 6) opened.

Stop: all valves closed.

4.12.5 Pressure variator

The pressure variator (Fig. 25), incorporated in the oil circuit valve group, makes it possible to vary the pressure on the nozzle line depending on the output required. The pressure on the nozzle line is adjusted by varying a section by means of the rotation of the servomotor, which also controls the gas butterfly valve at the same time.

- Regulator to 0° (minimum opening) = minimum pressure on nozzle line.
- Regulator to 90° (maximum opening) = maximum pressure on nozzle line.

The servomotor is controlled by the electronic cam; thanks to this device, it is possible to set different curves for oil and gas on the same servomotor (also for the air damper servomotor).

- When **adjusting the gas**, it is recommended to adjust the servomotor to about 90° to reduce leaks from the gas butterfly valve.
- When **adjusting the oil**, the adjustment is done based on the nozzle fitted and on the required degree of modulation; in a situation of minimum firing rate, a rotation of 20° can be enough.

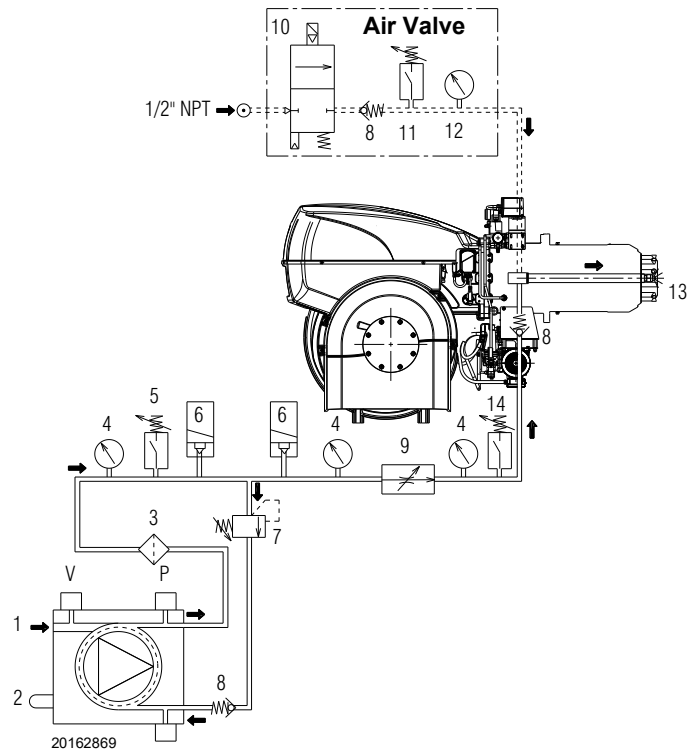

Fig. 24

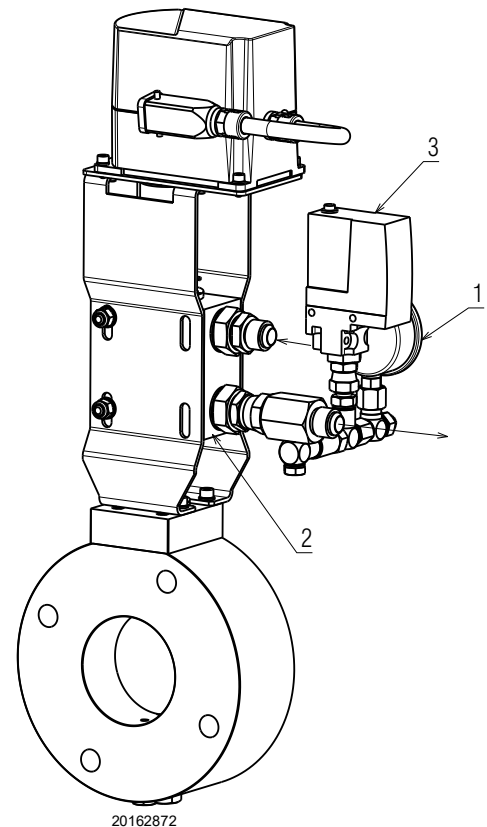

Fig. 25

Key (Fig. 25)

- 1 Outlet pressure gauge
- 2 Position indicator (0 ÷ 90) of the pressure variator
- 3 Max oil pressure switch

4.13 Pump

4.13.1 Technical data

Pump	SUNTEC TA5
Min. delivery rate at 300 psi pressure	1200 kg/h
Delivery pressure range	7 ÷ 30 bar / 101 ÷ 435 psi
Max. suction depression	0.45 bar / 6.5psi
Viscosity range	2 ÷ 75 cSt
Max. light oil temperature	150°C / 302°F
Max. suction and return pressure	5 bar / 72psi
Pressure calibration in the factory	30 bar / 435psi

Tab. M

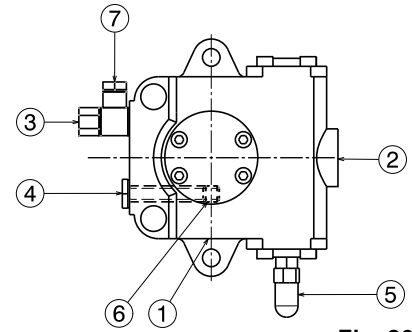
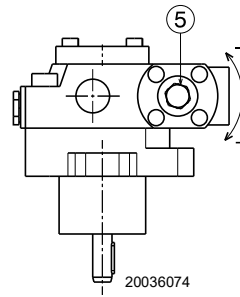

Fig. 26

4.13.2 Pump priming



Before starting the burner, make sure that the tank return line is not clogged.

Obstructions in the line could cause the sealing organ located on the pump shaft to break. (The pump leaves the factory with the by-pass closed).

- For self-priming to take place, the screw 3)(Fig. 26) of the pump must be loosened in order to bleed off the air contained in the suction line.
- The pump can be considered to be primed when the gas oil starts coming out of the screw 3).

The time required for this operation depends upon the diameter and length of the suction tubing. If the pump fails to prime at the first starting of the burner and the burner locks out, wait approx. 15 seconds, reset the burner, and then repeat the starting operation as often as required. After 5 or 6 starting operations allow 2 or 3 minutes for the transformer to cool.



The a.m. operation is possible because the pump is already full of fuel when it leaves the factory.

If the pump has been drained, fill it with fuel through the opening on the vacuum meter prior to starting; otherwise, the pump will seize.

Whenever the length of the suction piping exceeds 20-30 meters, the supply line must be filled using a separate pump.

Key (Fig. 26)

1	Suction	G 1/2"
2	Return	G 1/2"
3	Pressure gauge connection	G 1/4"
4	Vacuum meter connection	G 1/4"
5	Pressure adjustment screw	
6	Screw for by-pass	
7	Pressure gauge attachment	G 1/4"

4.14 Gas train supplied

It must be type-approved according to required standards and is supplied separately from the burner.



Explosion danger due to fuel leaks in the presence of a flammable source.

Precautions: avoid knocking, attrition, sparks and heat.

Make sure the fuel interception tap is closed before performing any operation on the burner.



The fuel supply line must be installed by qualified personnel, in compliance with current standards and laws.

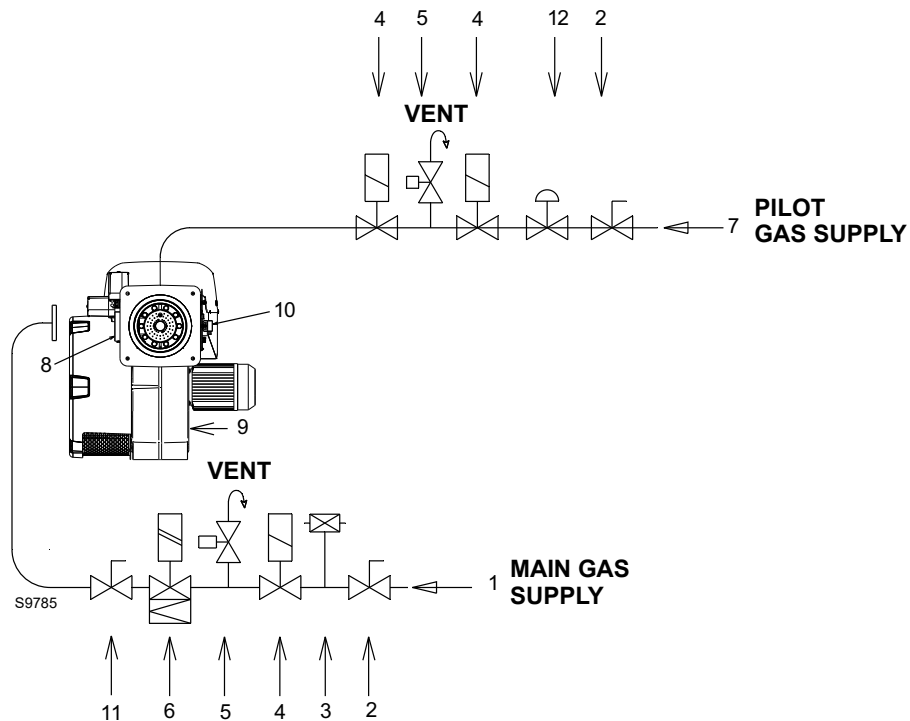

Fig. 27

Key to lay-out (Fig. 27)

- 1 Gas input pipe for main burner
- 2 Manual valve
- 3 Low gas pressure switch
- 4 Safety shut-off valve
- 5 NO vent valve
- 6 Regulating shut off valve
- 7 Gas input pipe for pilot
- 8 Gas adjustment butterfly valve
- 9 Burner
- 10 High gas pressure switch
- 11 Manual valve (for seal control)
- 12 Pilot regulator



Check that there are no gas leaks.



Pay attention when handling the train: danger of crushing of limbs.



Make sure that the gas train is properly installed by checking for any fuel leaks.



The operator must use the required equipment during installation.

4.14.1 Gas train

It must be type-approved according to UL Standards and is supplied separately from the burner.



See the accompanying instructions for the adjustment of the gas train.

WARNING

4.14.2 Gas pressure



WARNING

The pressure at the head of the burner refers to zero in the combustion chamber; to obtain true pressure, measured by a U-type manometer, add the counter-pressure of the boiler.

Gas pressure

	Mbtu/hr (GCV)	1 Δp ("WC)	2 Δp ("WC)
RLAS 1000/EV	14000	3.90	2.74
	19156	7.30	5.23
	24312	11.70	8.22
	29468	17.20	12.21
	34624	22.80	16.94
	39780	30.10	19.93
RLAS 1200/EV	20500	8.36	1.00
	25000	12.40	1.40
	29500	17.30	2.00
	34000	23.00	2.70
	38500	29.50	3.40
	43000	36.80	3.80

Tab. N



WARNING

The data of thermal output and combustion head gas pressure are related to full open (90°) gas butterfly valve.

4.14.3 Pilot - gas train connection

The burner is fitted with a dedicated gas train that is fixed to the pipe coupling.



WARNING

Supply pressure: see gas train specification.

4.14.4 Ignition pilot burner

For proper operation, adjust gas pressure (measured at pressure test point 1)(Fig. 28) as follows:

Model	Gas	"WC	SCFH
RLAS 1000/EV	Natural gas	16	435
RLAS 1200/EV	Natural gas	16	506

Tab. O



WARNING

Check pilot flame stability before starting up the main burner.

In the case of ignition problems check:

- correct positioning of the ignition electrode;
- the gas pressure, according to indications.

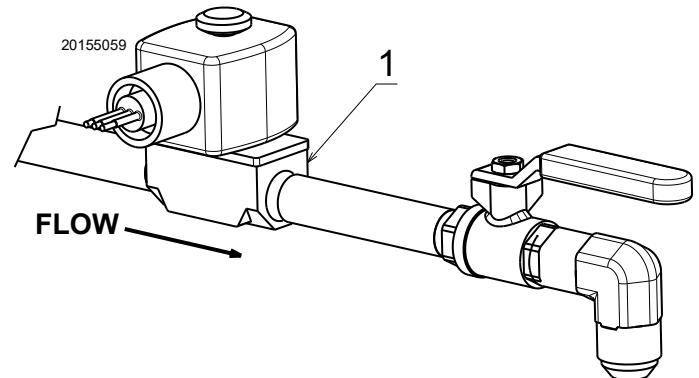

Fig. 28

4.15 Electrical wiring

4.15.1 Notes on safety for the electrical wiring



- The electrical wiring must be carried out with the electrical supply disconnected.
- Electrical wiring must be made in accordance with the regulations currently in force in the country of destination and by qualified personnel. Refer to the wiring diagrams.
- The manufacturer declines all responsibility for modifications or connections different from those shown in the wiring diagrams.
- Check that the electrical supply of the burner corresponds to that shown on the identification label and in this manual.
- The burner has been type-approved for intermittent operation (FS1). This means that it should as a rule be stopped at least once every 24 hours to enable the flame control to perform checks of its own start-up efficiency. Normally, burner stopping is guaranteed by the boiler's thermostat/pressure switch. If this is not the case, a time switch should be fitted in series to TL to stop the burner at least once every 24 hours. Refer to the wiring diagrams.
- The burner is factory set for FS1 operation (1 stop every 24 hours); it can be converted to FS2 operation (continuous - 1 stop every 72 hours), by changing the parameters using the menu of the AZL Display.
- The electrical safety of the device is obtained only when it is correctly connected to an efficient earthing system, made according to current standards. It is necessary to check this fundamental safety requirement. In the event of doubt, have the electrical system checked by qualified personnel. Do not use the gas tubes as an earthing system for electrical devices.
- The electrical system must be suitable for the maximum power absorption of the device, as indicated on the label and in the manual, checking in particular that the section of the cables is suitable for that level of power absorption.
- For the main power supply of the device from the electricity mains:
 - do not use adapters, multiple sockets or extensions;
 - make provisions for an omnipolar switch with a gap between the contacts of at least 3 mm (over-voltage category III), as required by current safety regulations.
- Do not touch the device with wet or damp body parts and/or in bare feet.
- Do not pull the electric cables.

4.15.2 Notes on terminals

On the electrical panel there terminals with a "spring" system. The opening of these terminals must be made via a suitable tool, using a flat-blade screwdriver of the correct size. The clamp uses a pressurised opening system.

Clamp opening

- insert the correct screwdriver into the opening, pushing down until the hole for the cable is completely open.
- Insert the previously stripped cable and remove the screwdriver. Make sure the cable is securely fastened Fig. 29.

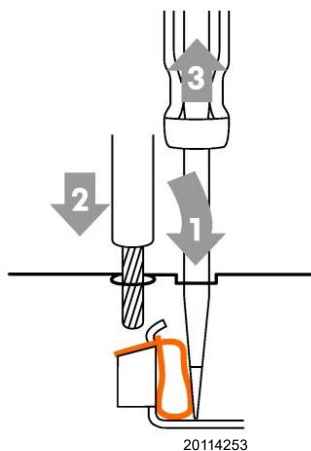

Fig. 29

Before carrying out any maintenance, cleaning or checking operations:



Turn off the burner's electrical supply using the main system switch.



Turn off the fuel interception tap.



Avoid condensate, ice and water leaks from forming.

If the cover is still present, remove it and proceed with the electrical wiring according to the wiring diagrams.

The use of the cable grommets can take various forms. By way of example we indicate the following mode (according to UL795).

4.15.3 Supply cables and external connections passage

All the cables to be connected to the burner are fed through the grommets (Fig. 30). The use of the cable grommets can take various forms.

By way of example we indicate the following mode (according to UL795):

- 1 Three phase power supply with 1" 1/2 cable grommet
- 2 Available: single phase power supply and other devices with 3/8 inch cable grommet
- 3 Available: consents/safety, minimum gas pressure switch, gas valves, pressure and temperature probe sensor and other devices with 1/2 inch cable grommet
- 4 Speed sensor cable (used in the factory)

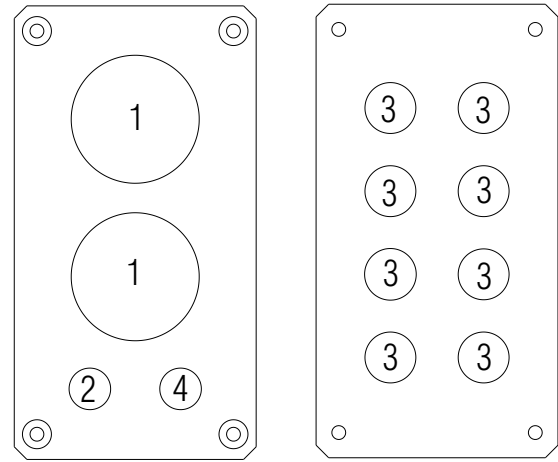

20108241

Fig. 30



The control panel is in compliance with UL508A.



After carrying out maintenance, cleaning or checking operations, reassemble the hood and all the safety and protection devices of the burner.

4.15.4 Shielding the connections



For the burner to operate correctly, where required, it is necessary to shield the connections.

To shield the motor connection, proceed as follows:

- to access the motor casing, loosen the four screws 1)(Fig. 31) and remove the cover 2).



To make the correct shielding, it is important to bear in mind the necessary length of the connections inside the motor casing.

- Shield the cable 4) running from the VSD (inverter), as shown in Fig. 32 and using the coupling 3);
- install the cable 4) with its connection to the motor casing, securing it carefully.
- Carry out the motor connection as shown in the wiring diagrams.
- Fix the grommets/cable terminals of the connections securely and tidily to the terminal board of the motor.
- Make a final visual check, then close the motor casing by tightening the 4 screws 1)(Fig. 31).

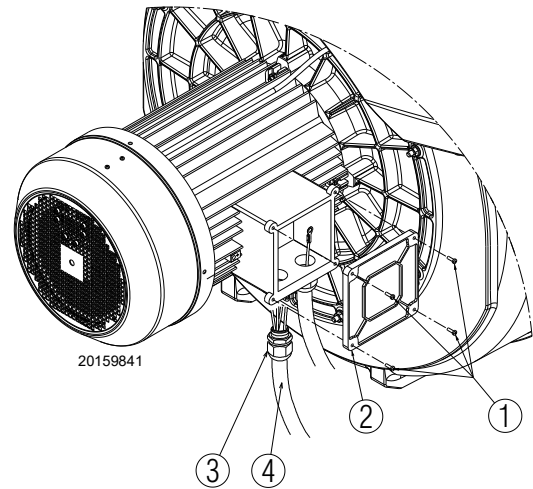

Fig. 31

4.15.5 Other connection



- 1 The connection from the Inverter to LMV52.... must be done as shown in Fig. 33.
- 2 Possible pressure/temperature probes and O₂ sensor connection must be done as shown in Fig. 33.
- 3 Possible pressure/temperature probes and O₂ sensor connection must be done as shown in Fig. 33.

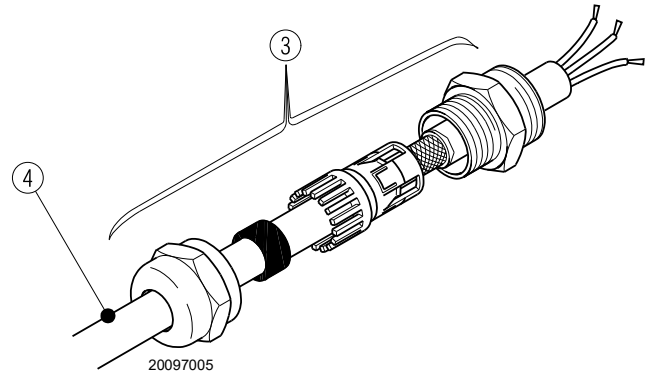

Fig. 32

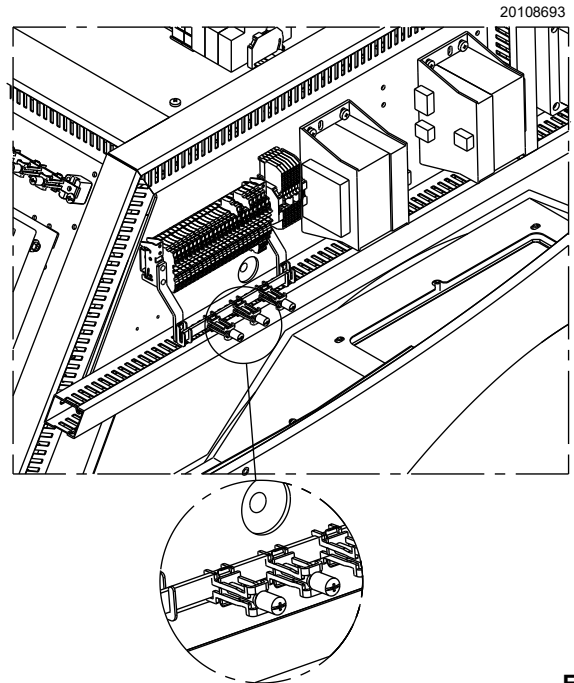

Fig. 33

4.16 Installation of shielded cables

In the case of clamp type **A**:

- unscrew the screw until space is created for inserting the shielding of the shielded cable A1)(Fig. 34);
- insert the shielded cable with the shielding inside the clamp A2);
- screw in the screw until it is completely tightened on the shielding A3).



WARNING

Do not overtighten.

In the case of clamp type **B**:

- pull the indicated tabs upwards and lift until locked in the open position B1)(Fig. 34);
- insert the shielded cable with the shielding inside the clamp B2);
- put pressure on the indicated part until the clamp closes automatically on the shielding B3).

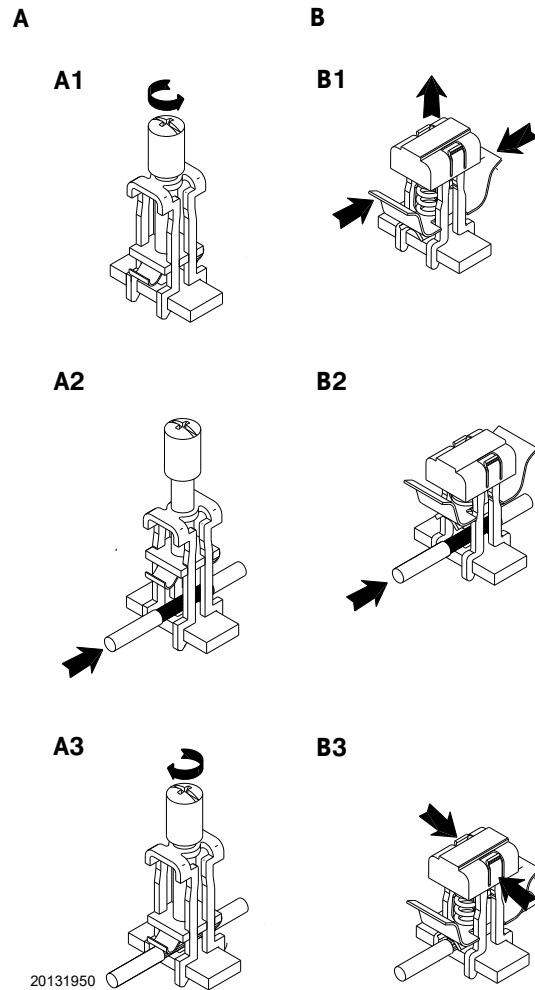

Fig. 34

4.16.1 Inverter connection



Following, it is reported an example how to connect the Inverter.
For further information, please refer to the relevant Inverter instruction manual.

Typical installation

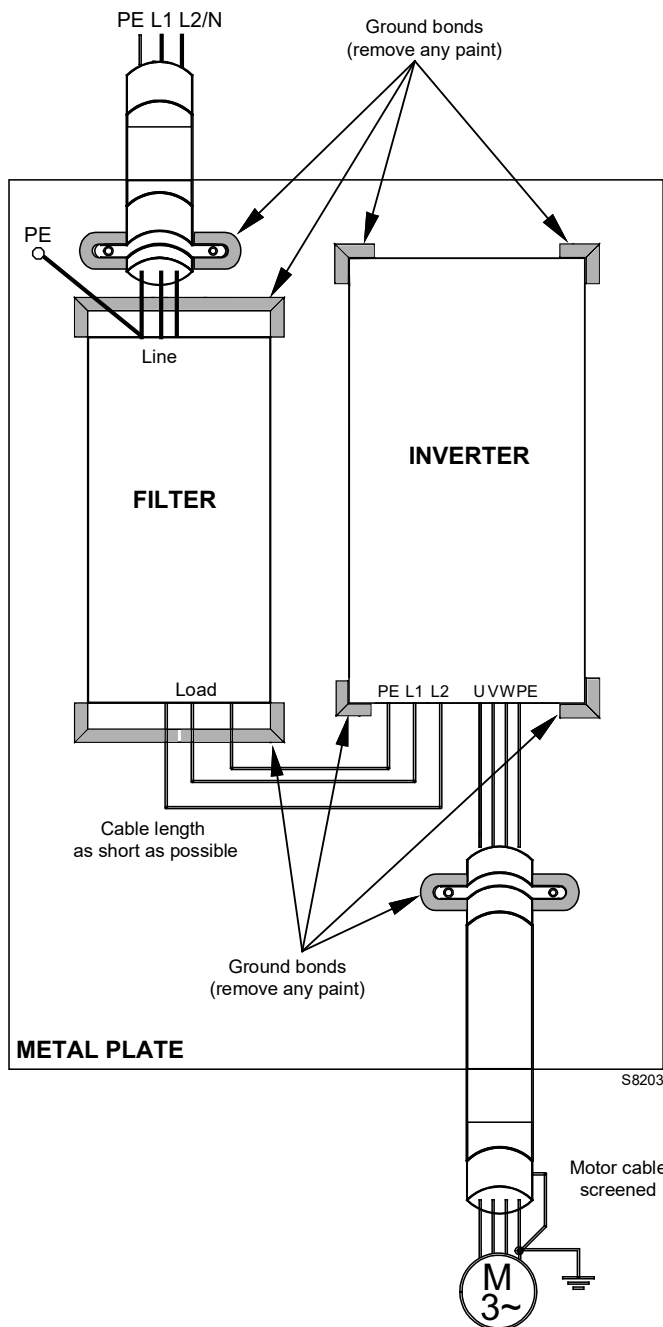

Fig. 35

Treatment of cables

Countermeasures against cable noise

The treatment of cables is the most important countermeasure. The machinery manufacturers are requested to examine the current structure of the cable lead - in.

- Use cables with woven screen
- The screen of the cable should be earthed with a large area.
- It is desirable to earth the screen of the cable by clamping the cable to the earth plate.
- The screen must be earthed on both side of the cable (take care for good earthing system).

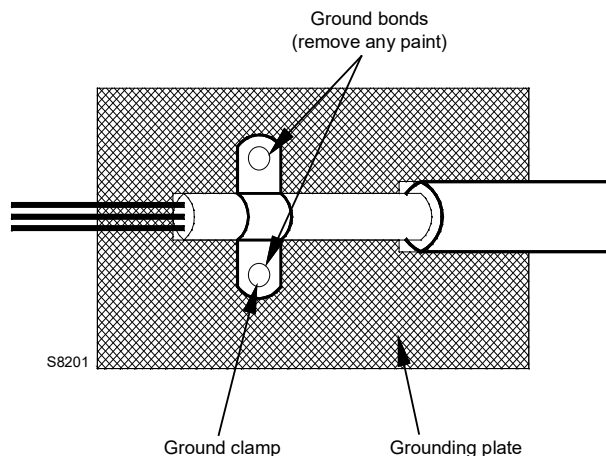

Fig. 36

Examples:

Number 1,2,3 show not proper ways to earth a cable screen.

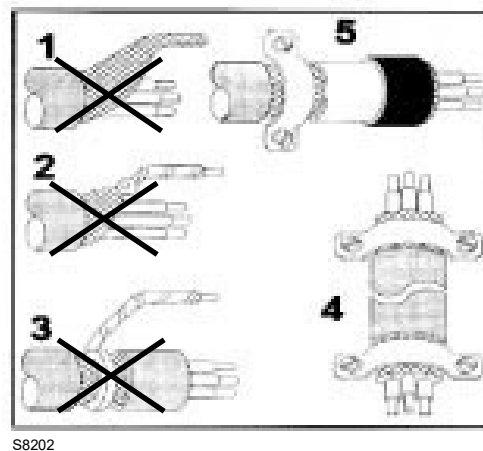

Fig. 37

4.17 Thermal relay calibration

Depending on the burner type, there are two different thermal relays:

- Electro-mechanical thermal relay (used for single phase motors)
- Electronic thermal relay (used for three phase motors)

4.17.1 Electro-mechanical thermal relay

The electro-mechanical thermal relay (Fig. 38) is used to avoid damage to the motor owing to a strong increase in absorption or the lack of a phase.

For the calibration, refer to the table given in electrical layout. If the minimum value of the scale of the thermal relay is greater than the rating absorption of the motor, protection is still ensured.

This arises when the power supply of the motor is 460V.

- To reset, in the case of an intervention of the thermal relay, press the button "RESET" (Fig. 38).
- The button "STOP" (Fig. 38) opens the NC (95-96) contact and stops the motor.

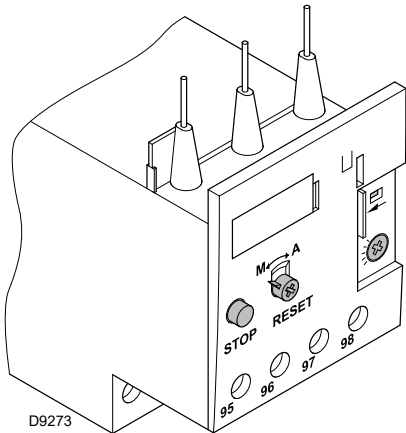

Fig. 38

- To test the thermal relay, insert a screwdriver in the window "TEST" (Fig. 39) and move it in the sense of the arrow (towards right).



Automatic resetting can be dangerous. This action is not provided for the burner operation.

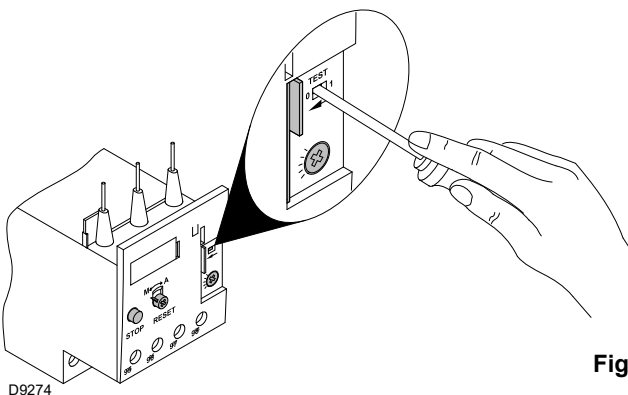

Fig. 39

4.17.2 Electronic thermal relay

- To reset, in the case of an intervention of the thermal relay, press the button "RESET" (Fig. 40).

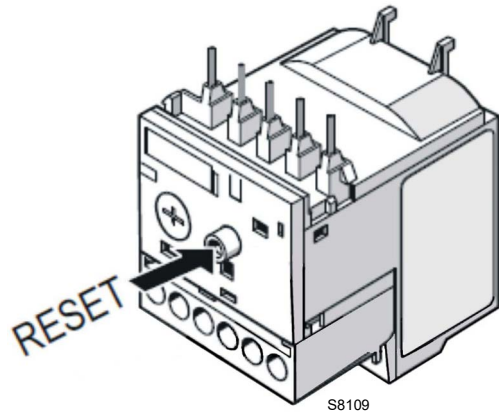

Fig. 40

There are two different solution to test the electronic thermal relay:

- **Device test (Fig. 41)**
Push slowly the button in the window with a little screwdriver.

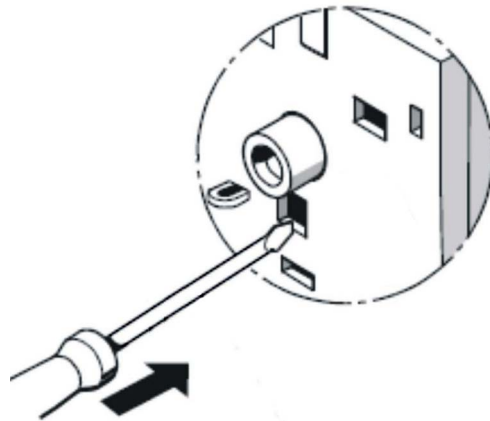

Fig. 41

- **Contact test NC (95-96) and NO (97-98)(Fig. 42)**
Insert in the window a little screwdriver and move it in the sense of the arrow.

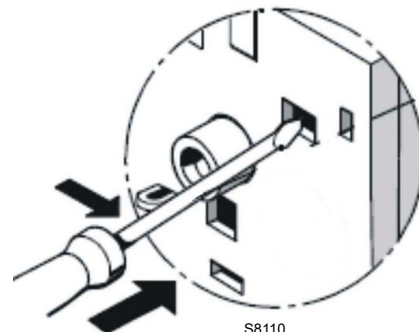

Fig. 42

4.18 Motor connection at 460V



WARNING

the motors, manufactured for 460 **IE3 NEMA Premium Efficiency** voltage, have the same connection than **IE2/Epact** motors.

Please, pay attention to the indications in case of modification of voltage, maintenance, or substitution.

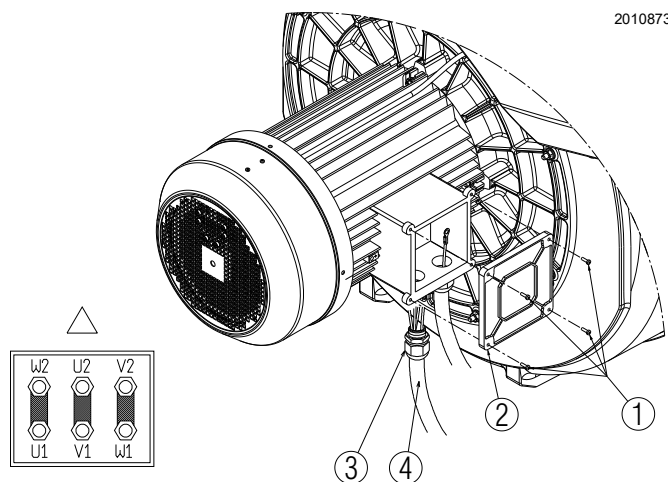

Fig. 43

5 Start-up, calibration and operation of the burner

5.1 Notes on safety for the first start-up



The first start-up of the burner must be carried out by qualified personnel, as indicated in this manual and in compliance with the standards and regulations of the laws in force.



Check the correct working of the adjustment, command and safety devices.



Refer to paragraph “Safety test - with gas ball valve closed” on page 43 before the first start-up.

5.2 Adjustments before first firing (light oil operation)

The optimum calibration of the burner requires an analysis of the flue gases at the boiler outlet and interventions on the following points.

5.2.1 Nozzles

See the information listed on page 24.

5.2.2 Combustion head

The adjustment of the combustion head is via the calibration points of the servomotor inside of the curve combustion.

The setting of the combustion head depends exclusively on the maximum delivery of the burner. In case of high altitude site, head

setting must refer to the “**Procedure to refer burner operating condition at an altitude and/or at a combustion supporter air temperature different to the standard values (328 ft above sea level, 68 °F).**” on page 9

5.2.3 Pump pressure

190 psi: this is the pressure calibrated in the factory which is usually sufficient for most purposes.

Sometimes, this pressure must be adjusted to **145 psi** in order to reduce fuel delivery.

This adjustment is possible only if the surrounding temperature remains above 0 °C.

5.3 Fuel change

There are two possible options for changing fuel:

- 1 using switch 2)(Fig. 46);
- 2 using a remote selector connected to the main terminal board.

By setting switch 1)(Fig. 46), to “remote” you activate the remote fuel selection facility.

In this position, if no remote selector is fitted, the display shows the priority fuel.

5.4 Adjustments before first firing (gas operation)

In addition, the following adjustments must also be made:

- open manual valves up-line from the gas train.
- Adjust the minimum gas pressure switch (Fig. 50, pag. 41) to the start of the scale.
- Adjust the maximum gas pressure switch (Fig. 49, pag. 41) to the end of the scale.
- Adjust the air pressure switch (Fig. 48, pag. 41) to the start of the scale.
- Purge the air from the gas line. Continue to purge the air (we recommend using a plastic tube routed outside the building) until gas is smelt.
- Fit a U-type manometer (Fig. 44) to the gas pressure test point on the sleeve. The manometer readings are used to calculate MAX. burner power.
- Connect two lamps or testers to the two gas line solenoid valves to check the exact moment at which voltage is supplied. This operation is unnecessary if each of the two solenoid valves is equipped with a pilot light that signals voltage passing through.



Before starting up the burner, it is good practice to adjust the gas train so that ignition takes place in conditions of maximum safety, i.e. with gas delivery at the minimum.

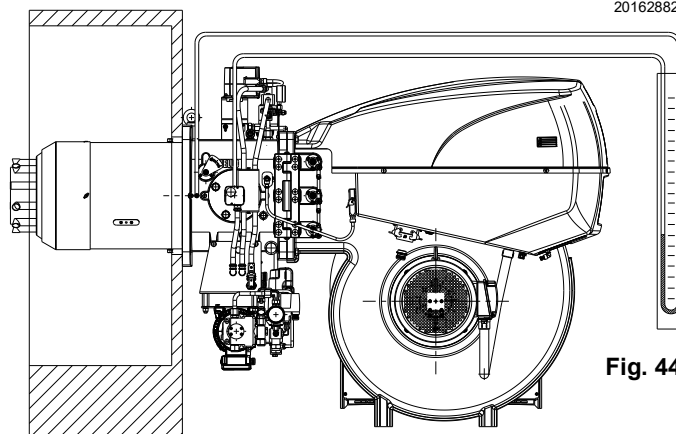

20162882

Fig. 44

5.5 Burner start-up

- Feed electricity to the burner via the disconnecting switch on the boiler panel.
- Close the thermostats/pressure switches.
- Close the local controls and position the selector 1)(Fig. 45) to “LOCAL”.

- When the limit thermostat (TL) is closed, the “CALL FOR HEAT” 2)(Fig. 45) signal must be on and the burner starts the starting cycle.

NOTE:
for further information, please refer to the specific instruction of the flame control.



Make sure that the lights or testers connected to the solenoids, or the pilot lights on the solenoids themselves, indicate that no voltage is present. If voltage is present, stop the burner immediately and check the electrical connections.

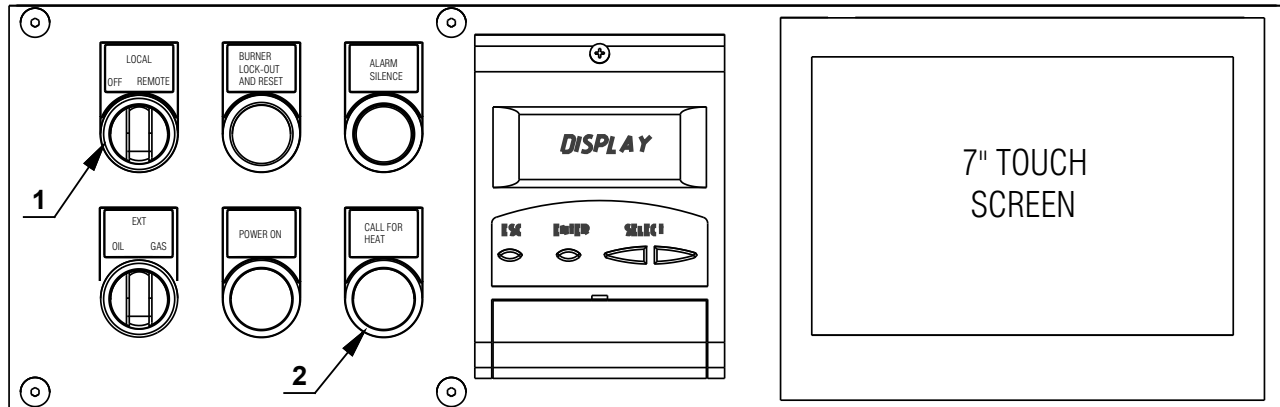

20110895

Fig. 45

5.6 Burner firing

Having completed the checks indicated in the previous heading, the ignition pilot of the burner should fire.

Set switch 1)(Fig. 46) to “LOCAL”.

Set switch 2)(Fig. 46) to the correct fuel.

If the motor starts but the flame does not appear and the flame safeguard goes into lock-out, reset and wait for a new firing attempt.

Check the control/ adjustment of the pilot (valve).

Having adjusted the pilot, reconnect the main valve and ignite the main flame; it might require several attempts to purge the air from the gas lines or to adjust the valve with little gas.

Once the burner has fired, now proceed with calibration operations.

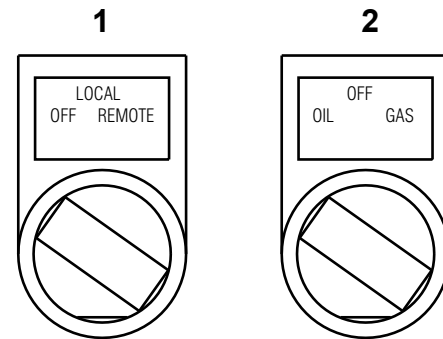

20152385

Fig. 46

5.6.1 Direction of motor rotation



WARNING

When the burner starts, check the direction of the motor rotation, as indicated in Fig. 47.

If the burner is not equipped with a device to check the phases sequence, the motor could rotate incorrectly. As soon as the burner starts up, look at the cooling fan of the fan motor and check it is rotating anticlockwise.

If this is not the case:

- place the switch of Fig. 47 in position “OFF” and wait for the flame control to carry out the switch-off phase;
- disconnect the electrical supply from the burner;
- invert the phases on the inverter output.

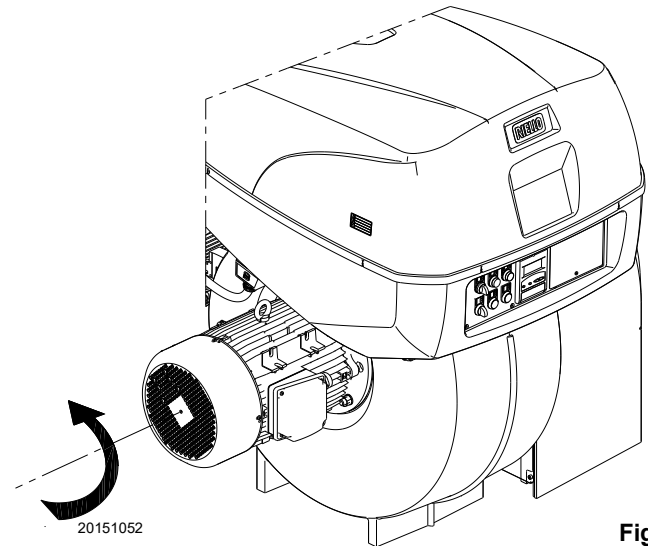

Fig. 47

5.7 Burner ignition

Once the above steps are complete, the burner should light.

If the motor starts up, but the flame does not appear and the flame control goes into lockout, reset it and wait for a new ignition attempt.

If ignition is still not achieved, it may be that gas is not reaching the combustion head within the safety time period of 3 seconds. In this case increase gas ignition delivery.

The arrival of gas at the pipe coupling is indicated by the U-type pressure gauge (Fig. 47).

If further burner lockouts occur, refer to the “Release procedure” given in the equipment manual supplied.

Once the burner has ignited, proceed with the global adjustment of the burner.

5.7.1 Air / gas adjustment and output modulation

The air/gas regulator and output modulation system equipping RS series burners performs a number of integrated functions to optimise burner function, in both individual installations and in combination with other units (e.g. double furnace boiler or multiple heat generators in parallel).

The basic system functions control:

- 1 The dosage of the air and fuel through positioning using direct servocommands of the relevant valves eliminating the possible play in the calibration systems with mechanical cam lever mechanisms, used on traditional modulating burners.
- 2 The modulation of the burner output in accordance with the load required by the system, with maintenance of the pressure or temperature of the boiler at the operating values set.
- 3 The sequence (cascade adjustment) of more than one boiler through the suitable connection of the various units and the activation of the internal software of the individual systems (option).

Further interfaces and communication functions with computers, for remote control or integration in central supervision systems are available on the basis of the configuration of the system.



WARNING

The first start up and every further internal setting operation of the adjustment system or the expansion of the base functions require access by means of password and are to be carried out by service personnel who are especially trained for the internal programming of the instrument and the specific application created with this burner.

The first start-up and curve synchronisation manual is supplied with the burner.

At request, the complete manual for the control and setting of all parameters is available.

5.8 Final calibration of the pressure switches

5.8.1 Air pressure switch

For the RLAS 1000-1200 burner model, the air pressure switch is connected in absolute mode and is activated by the positive pressure from the fan (Fig. 48).

Adjust the air pressure switch (Fig. 48) after having performed all other burner adjustments with the air pressure switch set to the min. of the scale.

With the burner operating at low fire, adjust the pressure switch by slowly turning the relative knob clockwise until the burner locks out.

Then turn the knob counter-clockwise about 20% of the set point and start-up the burner again to ensure the set point is correct.

If the burner locks out again, turn the knob counter-clockwise a little bit more.

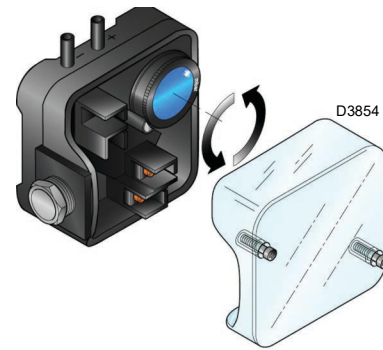

Fig. 48

5.8.2 Maximum gas pressure switch

Adjust the maximum gas pressure switch (Fig. 49) after making all other burner adjustments with the maximum gas pressure switch set to the end of the scale.

To calibrate the maximum gas pressure switch, open the tap and then connect a pressure gauge to its pressure test point.

The maximum gas pressure switch must be regulated to a value no higher than 30% of the measurement read on the gauge when the burner is working at maximum output.

After making the adjustment, remove the pressure gauge and close the tap.

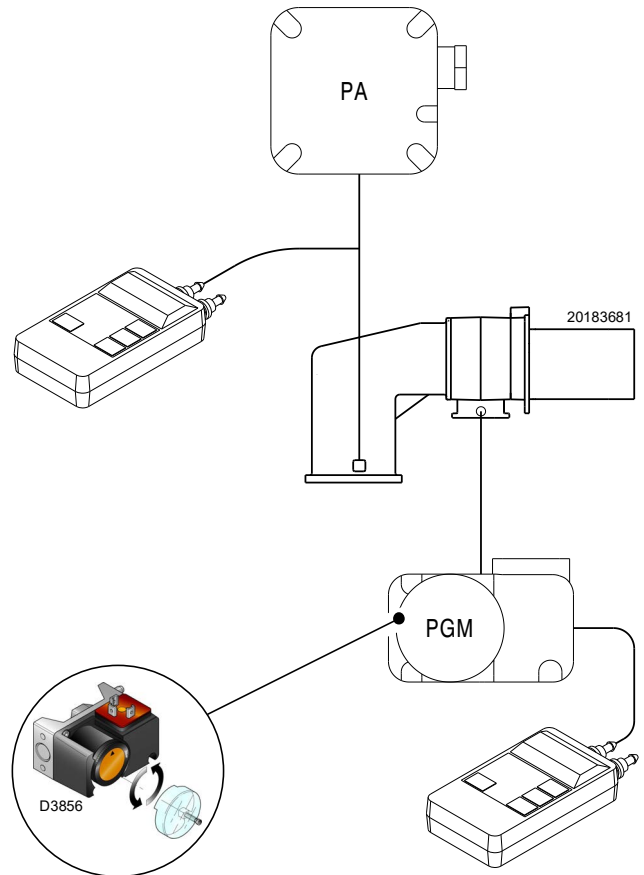

Fig. 49

5.8.3 Minimum gas pressure switch

The purpose of the minimum gas pressure switch is to prevent the burner from operating in an unsuitable way due to too low gas pressure.

Adjust the minimum gas pressure switch (Fig. 50) after having adjusted the burner, the gas valves and the gas train stabiliser. With the burner operating at maximum output:

- install a pressure gauge downstream of the gas train stabiliser (for example at the gas pressure test point on the burner combustion head);
- choke slowly the manual gas cock until the pressure gauge detects a decrease in the pressure read of about 0.1 kPa (1 mbar). In this phase, verify the CO value which must always be less than 100 mg/kWh (93 ppm).
- Increase the adjustment of the gas pressure switch until it intervenes, causing the burner shutdown;
- remove the pressure gauge and close the cock of the gas pressure test point used for the measurement;
- open completely the manual gas cock.



1 kPa = 10 mbar

WARNING

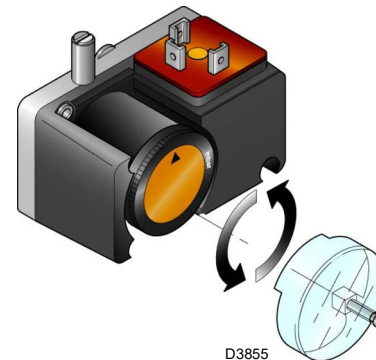

Fig. 50

5.8.4 Maximum/ low oil pressure switch

The low oil pressure switch (Fig. 51) is factory set to 145 PSI (10 bar).

If the oil pressure goes down this value in the delivery piping, the pressure switch stops the burner.

The max oil pressure switch (Fig. 52) is factory set to 115 PSI (8 bar).

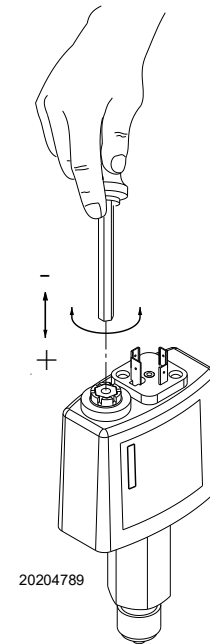

Fig. 51

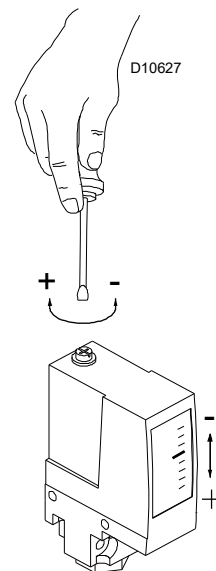

Fig. 52

5.9 Final checks (with the burner working)

<ul style="list-style-type: none"> ➤ Open the control limit operation ➤ Open the high limit operation 	➡	The burner must stop
<ul style="list-style-type: none"> ➤ Rotate the maximum gas pressure switch knob to the minimum end-of-scale position ➤ Rotate the air pressure switch knob to the maximum end of scale position 	➡	The burner must stop in lockout
<ul style="list-style-type: none"> ➤ Switch off the burner and disconnect the voltage ➤ Disconnect the minimum gas pressure switch 	➡	The burner must not start
<ul style="list-style-type: none"> ➤ Cover the flame sensor 	➡	The burner must stop in lockout due to firing failure

Tab. P



Make sure that the mechanical locking systems on the different adjustment devices are fully tightened.

6 Maintenance

6.1 Notes on safety for the maintenance

The periodic maintenance is essential for the good operation, safety, yield and duration of the burner.

It allows you to reduce consumption and polluting emissions and to keep the product in a reliable state over time.



The maintenance interventions and the calibration of the burner must only be carried out by qualified, authorised personnel, in accordance with the contents of this manual and in compliance with the standards and regulations of current laws.

Before carrying out any maintenance, cleaning or checking operations:



Disconnect the electrical supply from the burner by means of the main system switch.



Close the fuel interception tap.



Wait for the components in contact with heat sources to cool down completely.

6.2 Maintenance programme

6.2.1 Maintenance frequency



The gas combustion system should be checked at least once a year by a representative of the manufacturer or another specialised technician.



IF THE ELECTRICAL SUPPLY OF THE GAS VALVES OCCURS AT UNEXPECTED TIMES, DO NOT OPEN MANUAL GAS BALL VALVE, SWITCH OFF POWER LINE; CHECK THE WIRES; CORRECT THE ERRORS AND REPEAT THE COMPLETE TEST.

6.2.2 Safety test - with gas ball valve closed

It is fundamental to ensure the correct execution of the electrical connections between the gas solenoid valves and the burner to perform safely the commissioning.

For this purpose, after checking that the connections have been carried out in accordance with the burner's electrical diagrams, an ignition cycle with closed gas ball valve -dry test- must be performed.

- 13 The manual ball gas valve must be closed
- 14 The electrical contacts of the burner limit switch need to be closed
- 15 Ensures closed the contact of the low gas pressure switch
- 16 Make a trial for burner ignition

The start-up cycle must be as follows:

- Starting the fan for pre-ventilation
- Performing the gas valve seal control, if provided
- Completion of pre-ventilation
- Arrival of the ignition point
- Power supply of the ignition transformer
- Electrical Supply of solenoid gas valves

Since the manual gas ball valve is closed, the burner will not light up and its flame control will go to a safety lockout condition.

The actual electrical supply of the solenoid gas valves can be verified by inserting a tester. Some valves are equipped with light signals (or close/open position indicator) that turn on at the same time as their power supply.

6.2.3 Checking and cleaning



The operator must use the required equipment during maintenance.

Combustion

Carry out an analysis of the combustion discharge gases. Significant differences with respect to the previous check indicate the points where more care should be exercised during maintenance.

Combustion head

Open the burner and make sure that all components of the combustion head are in good condition, not deformed by the high temperatures, free of impurities from the surroundings and correctly positioned.

Fan

Check to make sure that no dust has accumulated inside the fan or on its blades, as this condition will cause a reduction in the air flow rate and provoke polluting combustion.

Burner

Clean the outside of the burner.

Measurement of detector current

Measurement of the detector's signal (Fig. 53) with a Voltmeter is not normally required since the flame signal's intensity is shown on the AZL...display and operating unit.

Min. value for a good work: 3.5 Vdc (AZL display flame approx. 50%).

If the value is lower, it can depend on:

- sensor positioned incorrectly;
- low current (lower than 96V);
- bad regulation of the burner.

To measure power, use a voltmeter with a 10 Vdc scale, connected as illustrated in Fig. 53.

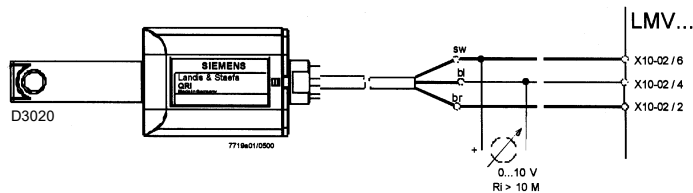

Fig. 53

Boiler

Clean the boiler as indicated in its accompanying instructions in order to maintain all the original combustion characteristics intact, especially the flue gas temperature and combustion chamber pressure.

GAS OIL OPERATION

Nozzles

It is advisable to replace nozzles once a year during periodical maintenance.

Do not clean the nozzle openings;

Hoses

Check that these are in good conditions.

Filters (Fig. 54)

Check the filtering baskets on line 1) and at nozzle 2) present in the system.

Clean or replace if necessary.

If rust or other impurities are observed inside the pump, use a separate pump to lift any water and other impurities that may have deposited on the bottom of the tank.

Fuel tank

Approximately every 5 years, suck any water on the bottom of the tank using a separate pump.

Combustion

If the combustion values found at the start of the intervention do not satisfy current standards or anyway indicate a poor state of combustion (consult the table below), contact the Technical Assistance Service for the necessary adjustments.

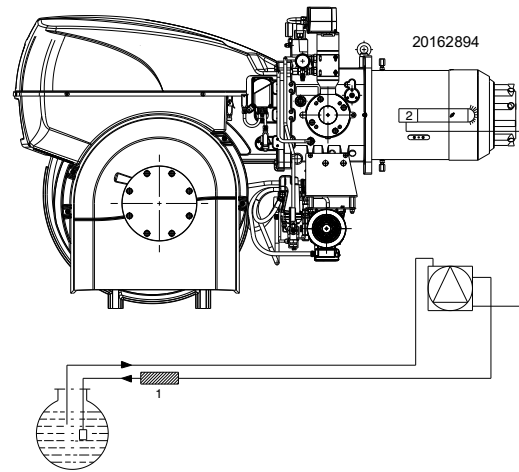

Fig. 54

GAS OPERATION

Gas leaks

Make sure that there are no gas leaks on the pipes between the gas meter and the burner.

Gas filter

Replace the gas filter when it is dirty.

Combustion

If the combustion values found at the start of the intervention do not satisfy current standards or anyway indicate a poor state of combustion (consult the table below), contact the Technical Assistance Service for the necessary adjustments.

6.2.4 Safety components

The safety components must be replaced at the end of their life cycle indicated in Tab. Q. The specified life cycles do not refer to the warranty terms indicated in the delivery or payment conditions.

Safety component	Life cycle
Flame control	10 years or 250,000 operation cycles
Flame sensor	10 years or 250,000 operation cycles
Gas valves (solenoid)	10 years or 250,000 operation cycles
Pressure switches	10 years or 250,000 operation cycles
Pressure adjuster	15 years
Servomotor (electronic cam) (if present)	10 years or 250,000 operation cycles
Oil valve (solenoid) (if present)	10 years or 250,000 operation cycles
Oil regulator (if present)	10 years or 250,000 operation cycles
Oil pipes/ couplings (metallic) (if present)	10 years
Fan impeller	10 years or 500,000 start-ups

Tab. Q

6.2.5 Electrical panel maintenance



Turn off the burner's power supply using the main system switch.

In the event of maintenance/replacement of components in the lower part of the electrical panel, access is possible via the front of the panel itself, following the directions below:

- unscrew the screws 2) (Fig. 56) of the control panel 1);
- extract the control panel and turn it 90°, hooking it with the brackets in the profile of the electrical panel 1);
- after performing the operation, install the control panel 1) in the electrical panel with the appropriate screws 2), arranging the cables present.



Failure to install the control panel in the seat of the electrical panel, results in the machine's loss of "IP" protection.

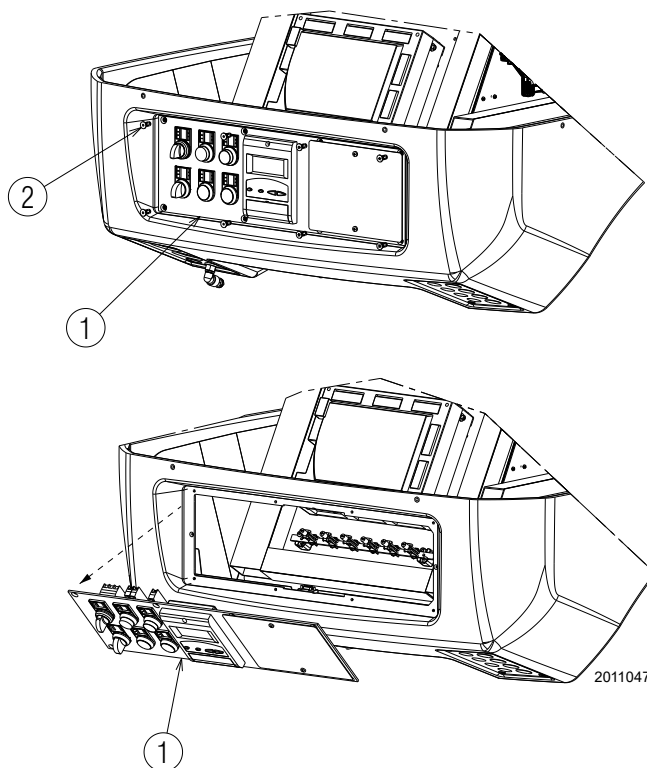

Fig. 56

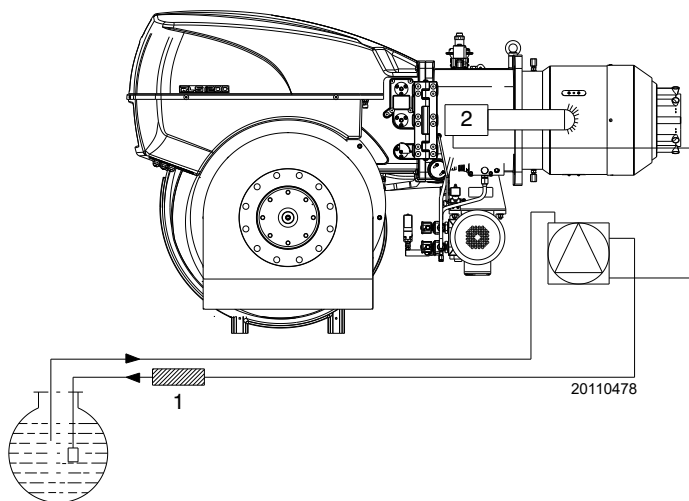

Fig. 55

6.3 Checking the position of the rpm sensor

To calibrate the rpm sensor 6)(Fig. 57), proceed as follows:

- remove the cover 1) unscrewing the screws 2);
- unscrew or screw the nuts 3) - 5) and the rpm detection disc 4) so that its distance from the rpm sensor 6) is about 2 mm.;
- place the plate 4) on the nut 5) and fix with the lock nut 3);
- close the cover 1) by screwing the screws 2).

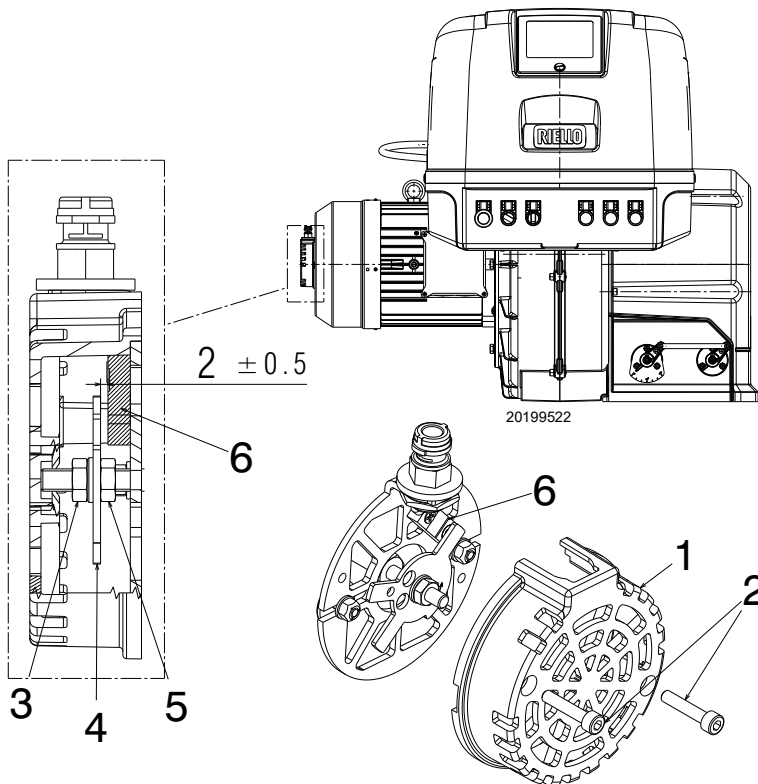

Fig. 57

Key (Fig. 57)

- 1 Cover
- 2 Screws for cover fixing
- 3 Lock nut
- 4 Rpm detection disc
- 5 Lower nut
- 6 Rpm sensor

6.4 Opening the burner



DANGER

Disconnect the electrical supply from the burner by means of the main system switch.



Wait for the components in contact with heat sources to cool down completely.



DANGER

Close the fuel interception tap.

For the burner opening, see **“Access to head internal part”** on page 22.

6.5 Closing the burner

Refit following the steps described but in reverse order; refit all burner components as they were originally assembled.



After carrying out maintenance, cleaning or checking operations, reassemble the cover and all the safety and protection devices of the burner.

7 **Faults - Possible causes - Solutions**

If faults arise in ignition or operations, the burner performs a “safety stop”, which is signalled by the red burner lockout LED.

The display visualises alternately the lockout code and the relative diagnostic. To reset the start-up conditions, refer to the “Reset procedure” indicated in the flame control manual supplied.

When the burner starts again, the red LED goes out and the flame control is reset.



WARNING

In the event of a burner lockout, more than two consecutive burner reset operations could cause damage to the installation. On the third lockout, contact the Aftersales Service.



DANGER

If further lockouts or burner faults occur, interventions must only be made by qualified, authorised personnel (as indicated in this manual, and in compliance with the laws and regulations currently in force).

A Appendix - Spare parts

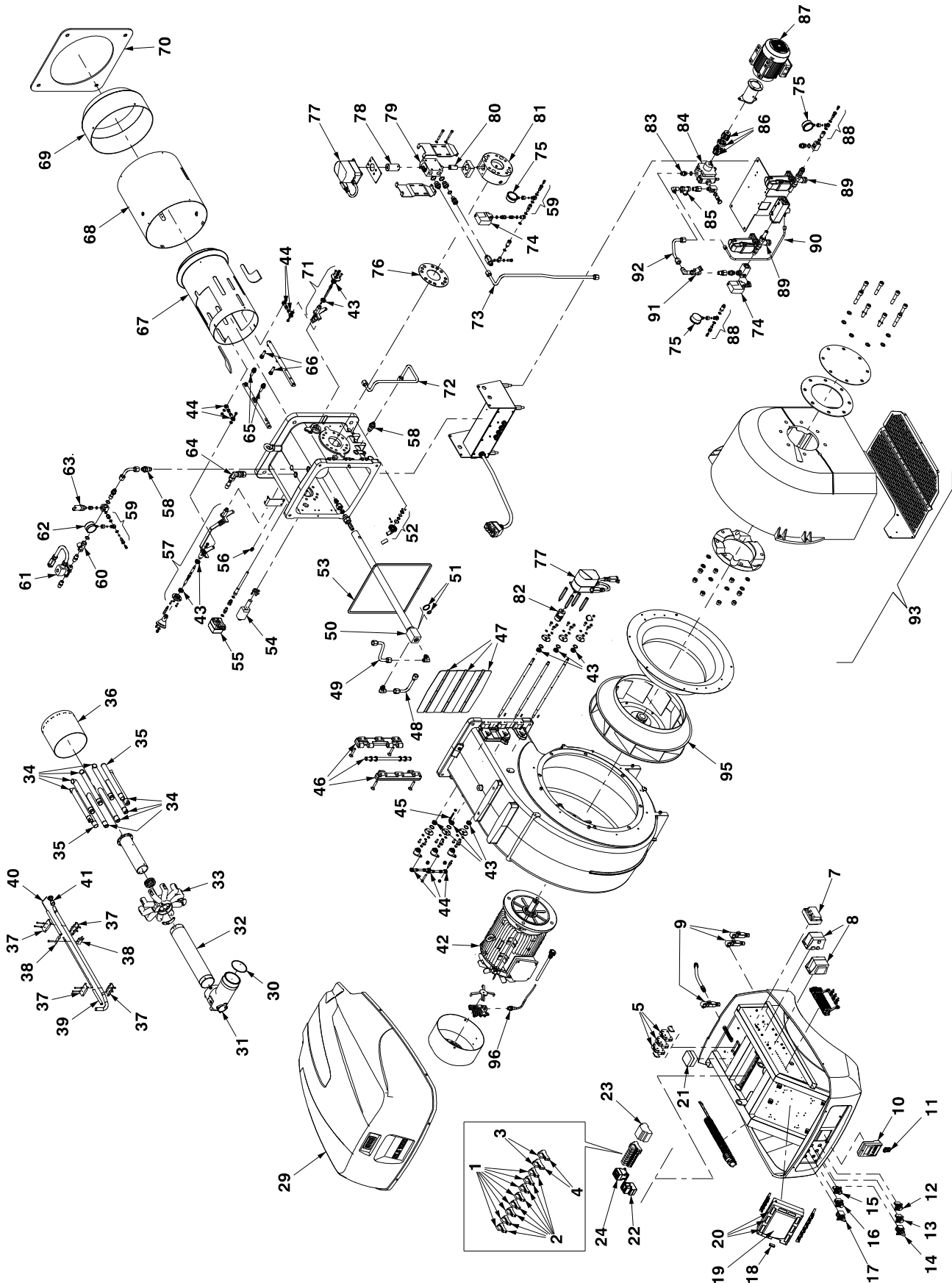

N.	CODE	20164347	20164348	20164351	20164352	DESCRIPTION	*
1	20010969	•	•	•	•	RELAY	C
2	3012841	•	•	•	•	BASE	
3	3020068	•	•	•	•	RELAY	C
4	3020071	•	•	•	•	BASE	
5	20014366	•	•	•	•	FUSE HOLDER	
7	3012956	•	•	•	•	TRANSFORMER	B
8	3013284	•	•	•	•	TRANSFORMER	B
9	3013363	•	•	•	•	CONNECTOR	C
10	3013283	•	•	•	•	DISPLAY	
11	3014113	•	•	•	•	PLUG	C
12	20036019	•	•	•	•	LAMP	
13	20036017	•	•	•	•	LAMP	
14	20028411	•	•	•	•	SELECTOR SWITCH	
15	20010962	•	•	•	•	BUTTON	
16	3013354	•	•	•	•	BUTTON	
17	20010963	•	•	•	•	SWITCH	C
18	3006211	•	•	•	•	FUSE	A
19	20014365	•	•	•	•	ELECTRONIC CAM	C
20	20132457	•	•	•	•	CONNECTORS ASSEMBLY	B
21	20013975	•	•	•	•	PRESSURE SWITCH	A
22	20112569	•	•	•	•	OVERLOAD	C
23	20133520	•	•	•	•	CONVERTER	
24	20112588	•	•	•	•	CONTACTOR	C
29	20063409	•	•	•	•	COVER	
30	3012868	•	•	•	•	O-RING	B
31	3013118	•	•	•	•	ELBOW	
32	20117840	•	•	•	•	GAS PIPE	C
33	3013105	•	•	•	•	DISTRIBUTOR	
34	20029690	•	•	•	•	GAS PIPE	C
35	20039358	•	•	•	•	GAS PIPE	C
36	20162934	•	•	•	•	DIFFUSER DISC	A
37	20125070	•	•	•	•	SUPPORT	A
38	20063280	•	•	•	•	SUPPORT	A
39	20013160	•	•	•	•	INSULATOR	A
40	20014630	•	•	•	•	ELECTRODE	A
41	20039355	•	•	•	•	DIFFUSER	C
42	20014024	•	•			MOTOR	C
42	20158749			•	•	MOTOR	C
43	3012795	•	•	•	•	BEARING	
44	3012669	•	•	•	•	PIN JOINT	C
45	3003891	•	•	•	•	CONNECTOR	C
46	3012797	•	•	•	•	HINGE	
47	20032625	•	•	•	•	AIR DAMPER	
48	20158689	•	•	•	•	TUBE	C
49	20158690	•	•	•	•	TUBE	C
50	20158691	•	•	•	•	LANCE	

N.	CODE	20164347	20164348	20164351	20164352	DESCRIPTION	*
51	20027080	•	•	•	•	PISTON SEALS	B
52	3013933	•	•	•	•	INSPECTION WINDOW	
53	20068181	•	•	•	•	SEAL	B
54	20039362	•	•	•	•	PROBE	A
55	20014103	•	•	•	•	PRESSURE SWITCH	A
56	3005447	•	•	•	•	CONNECTOR	C
57	20143407	•	•	•	•	LEVER ASSEMBLY	
58	20039375	•	•	•	•	CONNECTOR	C
59	20144627	•	•	•	•	CONNECTOR	C
60	20023125	•	•	•	•	NON-RETURN VALVE	B
61	20157488	•	•	•	•	NEEDLE VALVE	B
62	20157479	•	•	•	•	PRESSURE GAUGE	
63	20157475	•	•	•	•	PRESSURE SWITCH	A
64	20014633	•	•	•	•	CONNECTOR	C
65	20052991	•	•	•	•	BAR	C
66	20052992	•	•	•	•	BAR	C
67	20052999	•	•	•	•	SHUTTER	C
68	20090597	•	•			CYLINDER	C
68	20090461			•	•	CYLINDER	C
69	3013100	•	•			FLAME FUNNEL	B
69	3013391			•	•	FLAME FUNNEL	B
70	3013104	•	•			FLANGE GASKET	A
70	3013392			•	•	FLANGE GASKET	A
71	20113414	•	•	•	•	LEVER ASSEMBLY	
72	20158706	•	•	•	•	TUBE	C
73	20158708	•	•	•	•	TUBE	C
74	3012384	•	•	•	•	PRESSURE SWITCH	A
75	3006140	•	•	•	•	PRESSURE GAUGE	
76	3013430	•	•	•	•	SEAL	B
77	20029137	•	•	•	•	SERVOMOTOR	B
78	20129116	•	•	•	•	COUPLING	A
79	20110042	•	•	•	•	MODULATOR	B
80	20140541	•	•	•	•	COUPLING	A
81	20158710	•	•	•	•	REGULATOR	C
82	20039351	•	•	•	•	COUPLING	A
83	3003225	•	•	•	•	CONNECTOR	C
84	3006410	•	•	•	•	PUMP	C
85	20029257	•	•	•	•	NON-RETURN VALVE	B
86	20041421	•	•	•	•	COUPLING	A
87	20042836	•	•	•	•	MOTOR	C
88	20132849	•	•	•	•	CONNECTOR	C
89	20029212	•	•	•	•	SAFETY VALVE	B
90	20144620	•	•	•	•	TUBE	C
91	20029233	•	•	•	•	FILTER	B
92	20158713	•	•	•	•	TUBE	C
93	20158779	•	•	•	•	FILTER	B

N.	CODE	20164347	20164348	20164351	20164352	DESCRIPTION	*
95	20045909	•	•			FAN	C
95	20093001			•	•	FAN	C
96	20202970	•	•	•	•	SERNSOR	A

*******ADVISED PARTS**

A = Spare parts for minimum fittings

A+B = Spare parts for basic safety fittings

A+B+C = Spare parts for extended safety fittings

RIELLO

RIELLO S.p.A.
I-37045 Legnago (VR)
Tel.: +39.0442.630111
[http:// www.riello.com](http://www.riello.com)

RIELLO

35 Pond Park Road
Hingham, Massachusetts,
U.S.A. 02043

RIELLO BURNERS NORTH AMERICA
<http://www.riello.ca>

1-800-4-RIELLO

2165 Meadowpine Blvd
Mississauga, Ontario
Canada L5N 6H6