

GB Dual fuel light oil/gas burners

Progressive two stage or modulating operation



CODE	MODEL
20171536	RLS 190/E
20171537	RLS 190/E
20171675	RLS 190/E



Original instructions

1	Information and general instructions	3
1.1	Information about the instruction manual	3
1.1.1	Introduction	3
1.1.2	General dangers	3
1.1.3	Other symbols	3
1.1.4	Delivery of the system and the instruction manual.	4
1.2	Guarantee and responsibility	4
2	Safety and prevention.	5
2.1	Introduction	5
2.2	Personnel training	5
3	Technical description of the burner	6
3.1	Technical data	6
3.2	Electrical data	6
3.3	Burner models designation	7
3.4	Packaging - Weight - Approximate measurements	7
3.5	Burner dimensions	7
3.6	Firing rate	8
3.6.1	Procedure to refer burner operating condition at an altitude and/or at a combustion supporter air temperature different to the standard values (328 ft above sea level, 68 °F).	9
3.7	Minimum furnace dimensions	10
3.8	Commercial boilers	10
3.9	Standard equipment.	10
3.10	Burner description	11
3.11	Control box for the air/fuel ratio (LMV36...)	12
3.12	Actuators (SQM33.5...)	15
4	Installation	16
4.1	Notes on safety for the installation.	16
4.2	Handling.	16
4.3	Preliminary checks.	16
4.4	Burner raising.	17
4.5	Preparing the boiler	17
4.5.1	Boring the boiler plate	17
4.5.2	Blast tube length	17
4.6	Securing the burner to the boiler	18
4.7	Nozzle installation	19
4.7.1	Nozzle assembly	19
4.7.2	Adjusting the nozzle flow rate	20
4.8	Ignition pilot adjustment.	21
4.9	Combustion head setting	21
4.10	Burner refitting	22
4.11	Light oil supply	23
4.11.1	Fuel supply.	23
4.11.2	Hydraulic connections	24
4.11.3	Pump	24
4.11.4	Pump priming.	24
4.12	Gas feeding	25
4.12.1	Gas train.	25
4.12.2	Gas valve electrical connections	26
4.12.3	Gas pressure	28
4.13	Electrical wiring	29
4.13.1	Notes on terminals	29

4.13.2	Supply cables and external connections passage	30
4.14	Overload relay and motor protector calibration	31
4.14.1	Electro-mechanical overload relay	31
4.14.2	Electronic relay	31
4.15	Motor protector	32
4.15.1	Device test	32
4.16	Motor connection at 208-230 or 460V	33
4.17	Motor connection at 575V	33
4.18	Motor rotation	33
5	Start-up, calibration and operation of the burner	34
5.1	Notes on safety for the first start-up	34
5.2	Adjustments before first firing (light oil operation)	34
5.2.1	Combustion head setting	34
5.2.2	Pump adjustment	34
5.2.3	Air damper adjustment	34
5.2.4	Electrode position	34
5.3	Burner firing	34
5.4	Burner calibration	34
5.5	Adjustments before first firing (gas operation)	35
5.6	Burner start-up	35
5.6.1	Adjusting gas/air delivery	35
5.6.2	Adjusting oil/air delivery	35
5.7	Final calibration of the pressure switches	36
5.7.1	Air pressure switch	36
5.7.2	Maximum gas pressure switch	36
5.7.3	Minimum gas pressure switch	37
5.7.4	Low oil pressure switch	37
5.7.5	High oil pressure switch	37
5.8	Burner starting	38
5.8.1	Steady state operation	38
5.8.2	Firing failure	38
5.9	Flame signal measurement	38
5.10	Final checks (with the burner working)	39
6	Maintenance	40
6.1	Notes on safety for the maintenance	40
6.2	Maintenance programme	40
6.2.1	Maintenance frequency	40
6.2.2	Safety test - with gas ball valve closed	40
6.2.3	Checking and cleaning	40
6.2.4	Safety components	41
6.3	Opening the burner	42
6.4	Closing the burner	42
A	Appendix - Spare parts	43
B	Appendix - Accessories	47
C	Appendix - Burner start up report	48

1 Information and general instructions

1.1 Information about the instruction manual

1.1.1 Introduction

The instruction manual supplied with the burner:

- is an integral and essential part of the product and must not be separated from it; it must therefore be kept carefully for any necessary consultation and must accompany the burner even if it is transferred to another owner or user, or to another system. If the manual is lost or damaged, another copy must be requested from the Technical Assistance Service of the area;
- is designed for use by qualified personnel;
- offers important indications and instructions relating to the installation safety, start-up, use and maintenance of the burner.

Symbols used in the manual

In some parts of the manual you will see triangular DANGER signs. Pay great attention to these, as they indicate a situation of potential danger.

1.1.2 General dangers

The **dangers** can be of **3 levels**, as indicated below.



DANGER

Maximum danger level!

This symbol indicates operations which, if not carried out correctly, cause serious injury, death or long-term health risks.



WARNING

This symbol indicates operations which, if not carried out correctly, may cause serious injury, death or long-term health risks.



CAUTION

This symbol indicates operations which, if not carried out correctly, may cause damage to the machine and/or injury to people.

1.1.3 Other symbols



DANGER

DANGER: LIVE COMPONENTS

This symbol indicates operations which, if not carried out correctly, lead to electric shocks with lethal consequences.



DANGER: FLAMMABLE MATERIAL

This symbol indicates the presence of flammable materials.



DANGER: BURNING

This symbol indicates the risks of burns due to high temperatures.



DANGER: CRUSHING OF LIMBS

This symbol indicates the presence of moving parts: danger of crushing of limbs.



WARNING: MOVING PARTS

This symbol indicates that you must keep limbs away from moving mechanical parts; danger of crushing.



DANGER: EXPLOSION

This symbol signals places where an explosive atmosphere may be present. An explosive atmosphere is defined as a mixture - under atmospheric conditions - of air and flammable substances in the form of gases, vapours, mist or dust in which, after ignition has occurred, combustion spreads to the entire unburned mixture.



PERSONAL PROTECTION EQUIPMENT

These symbols indicate the equipment that must be worn and kept by the operator for protection against threats against safety and/or health while at work.



OBLIGATION TO ASSEMBLE THE HOOD AND ALL THE SAFETY AND PROTECTION DEVICES

This symbol signals the obligation to reassemble the hood and all the safety and protection devices of the burner after any maintenance, cleaning or checking operations.



ENVIRONMENTAL PROTECTION

This symbol gives indications for the use of the machine with respect for the environment.



IMPORTANT INFORMATION

This symbol indicates important information that you must bear in mind.



This symbol indicates a list.

Abbreviations used

Ch.	Chapter
Fig.	Figure
Page	Page
Sec.	Section
Tab.	Table

1.1.4 Delivery of the system and the instruction manual

When the system is delivered, it is important that:

- the instruction manual is delivered to the user by the system manufacturer, with the recommendation to keep it in the room where the heat generator is to be installed.
- The instruction manual shows:
 - the serial number of the burner;

.....

- the address and telephone number of the nearest Assistance Centre.

.....

.....

.....

- The system supplier must carefully inform the user about:
 - the use of the system;
 - any further tests that may be required before activating the system;
 - maintenance, and the need to have the system checked at least once a year by a representative of the manufacturer or another specialised technician.

To ensure a periodic check, the manufacturer recommends the drawing up of a Maintenance Contract.

1.2 Guarantee and responsibility

The manufacturer guarantees its new products from the installation date, in accordance with the regulations in force and/or the sales contract. At the moment of the first start-up, check that the burner is integral and complete.



WARNING

Failure to observe the information given in this manual, operating negligence, incorrect installation and carrying out of non authorised modifications will result in the annulment by the manufacturer of the guarantee that it supplies with the burner.

In particular, the rights to the guarantee and the responsibility will no longer be valid, in the event of damage to things or injury to people, if such damage/injury was due to any of the following causes:

- incorrect installation, start-up, use and maintenance of the burner;
- improper, incorrect or unreasonable use of the burner;
- intervention of unqualified personnel;
- carrying out of unauthorised modifications on the equipment;
- use of the burner with safety devices that are faulty, incorrectly applied and/or not working;
- installation of untested supplementary components on the burner;
- powering of the burner with unsuitable fuels;
- faults in the fuel supply system;
- use of the burner even following an error and/or an irregularity;
- repairs and/or overhauls incorrectly carried out;
- modification of the combustion chamber with inserts that prevent the regular development of the structurally established flame;
- insufficient and inappropriate surveillance and care of those burner components most likely to be subject to wear and tear;
- the use of non-original components, including spare parts, kits, accessories and optional;
- force majeure.

The manufacturer furthermore declines any and every responsibility for the failure to observe the contents of this manual.

2 Safety and prevention

2.1 Introduction

The burners have been designed and built in compliance with current regulations and directives, applying the known technical rules of safety and envisaging all the potential danger situations.

It is necessary, however, to bear in mind that the imprudent and clumsy use of the equipment may lead to situations of death risk for the user or third parties, as well as the damaging of the burner or other items. Inattention, thoughtlessness and excessive confidence often cause accidents; the same applies to tiredness and sleepiness.

It is a good idea to remember the following:

- The burner must only be used as expressly described. Any other use should be considered improper and therefore dangerous.

In particular:

it can be applied to boilers operating with water, steam, diathermic oil, and to other uses expressly named by the manufacturer;

the type and pressure of the fuel, the voltage and frequency of the electrical power supply, the minimum and maximum deliveries for which the burner has been regulated, the pressurisation of the combustion chamber, the dimensions of the combustion chamber and the room temperature must all be within the values indicated in the instruction manual.

- Modification of the burner to alter its performance and destinations is not allowed.
- The burner must be used in exemplary technical safety conditions. Any disturbances that could compromise safety must be quickly eliminated.
- Opening or tampering with the burner components is not allowed, apart from the parts requiring maintenance.
- Only those parts envisaged by the manufacturer can be replaced.



The manufacturer guarantees safety and proper functioning only if all burner components are intact and positioned correctly.

2.2 Personnel training

The user is the person, body or company that has acquired the machine and intends to use it for the specific purpose. He is responsible for the machine and for the training of the people working around it.

The user:

- Undertakes to entrust the machine exclusively to suitably trained and qualified personnel;
- Undertakes to inform his personnel in a suitable way about the application and observance of the safety instructions. With that aim, he undertakes to ensure that everyone knows the use and safety instructions for his own duties;
- Personnel must observe all the danger and caution indications shown on the machine.
- Personnel must not carry out, on their own initiative, operations or interventions that are not within their province.
- Personnel must inform their superiors of every problem or dangerous situation that may arise.
- The assembly of parts of other makes, or any modifications, can alter the characteristics of the machine and hence compromise operating safety. The manufacturer therefore declines any and every responsibility for any damage that may be caused by the use of non-original parts.

In addition:



- the user must take all the measures necessary to prevent unauthorised people gaining access to the machine;
- the user must inform the manufacturer if faults or malfunctioning of the accident prevention systems are noticed, along with any presumed danger situation.
- personnel must always use the personal protective equipment envisaged by legislation and follow the indications given in this manual.

3

Technical description of the burner

3.1 Technical data

Model			RLS 190/E	
Output ⁽¹⁾ Delivery ⁽¹⁾	High	MBtu/hr ⁽⁴⁾ kW GPH	3553 - 7560 (6874*) 1041 - 2215 (2014*) 25.3 - 54 (49.1*)	
	Low	MBtu/hr ⁽⁴⁾ kW GPH	1992 583 14.2	
Fuel			#2 Fuel oil - Natural gas	
Gas pressure at maximum delivery ⁽²⁾ Gas: Natural gas		" WC	5.5	
Operation			Modulating oil/gas	
Nozzle		number	1	
Standard applications			Boilers: water, steam, thermal oil	
Ambient temperature		°F	32 - 104 (0 - 40 °C)	
Combustion air temperature		°F max	140 (60 °C)	
Pump delivery (at 174 PSI) pressure range fuel temperature	GPH		150	
	PSI		102 - 580	
	° F max		194 (90 °C)	
Electrical protection			NEMA 1	
Noise levels ⁽³⁾	Sound pressure	dB(A)	85	
	Sound power		96	

Tab. A

(*) Firing rate for C - UL Canadian Listing (CNL).

(1) Reference conditions: Ambient temperature 68 °F (20°C) - Barometric pressure 394" WC - Altitude 329 ft.

(2) Pressure at test point 18)(Fig. 6, page 11) with zero pressure in the combustion chamber and maximum burner output.

(3) Sound pressure measured in manufacturer's combustion laboratory, with burner operating on test boiler and at maximum rated output. The sound power is measured with the "Free Field" method, as per EN 15036, and according to an "Accuracy: Category 3" measuring accuracy, as set out in EN ISO 3746.

(4) Equivalent Btu values based on 1 USGPH = 140,000 Btu/hr.

3.2 Electrical data

Model			RLS 190/E		
Control circuit power supply		V/Ph/Hz	120/1/60		
Main power supply (+/- 10%)		V/Ph/Hz	208-230/3/60	460/3/60	575/3/60
Fan motor IE3	rpm		3530	3530	3500
	HP		7.5	7.5	7.5
	V		208-230	460	575
	A		17.8	8.9	7.1
Pump motor	rpm		3525	3525	3520
	HP		1	1	1
	V		208-230	460	575
	A		3.0	1.5	1.2
Ignition transformer	Oil	V1 - V2	120 V - 2 x 5 kV		
		I1 - I2	2.7 A - 30 mA		
	Gas	V1 - V2	120 V - 1 x 8 kV		
		I1 - I2	1.6 A - 20 mA		
Electrical power consumption		W max	7400	7400	7400
Electrical control circuit consumption		W	750		
Total electrical consumption		W	8150	8150	8150
Electrical protection			NEMA 1		

Tab. B

3.3 Burner models designation

Model	Riello Code	RBNA Code	Voltage	Flame safeguard
RLS 190/E	20163121	20171536	208-230/3/60	Burner mounted
RLS 190/E		20171675	460/3/60	Burner mounted
RLS 190/E	20163126	20171537	575/3/60	Burner mounted

Tab. C

3.4 Packaging - Weight - Approximate measurements

The burners are skid mounted. Outer dimensions of packaging are indicated in Tab. D.

The weight of the burner complete with packaging is indicated in Tab. D.

inch	A	B	C	lbs
RLS 190/E	59 ³ / ₆₄ "	33 ¹ / ₈ "	39 ³ / ₈ "	340

Tab. D

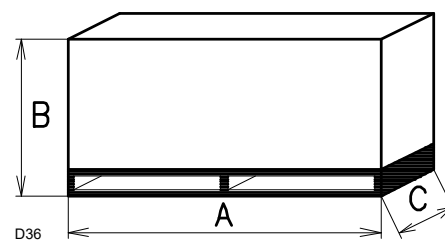

Fig. 1

3.5 Burner dimensions

The maximum dimensions of the burners are given in Fig. 2.

Inspection of the combustion head requires the burner to be opened and the rear part withdrawn on the slide bars.

The maximum dimension of the burner when open, without casing, is give in measurement V.

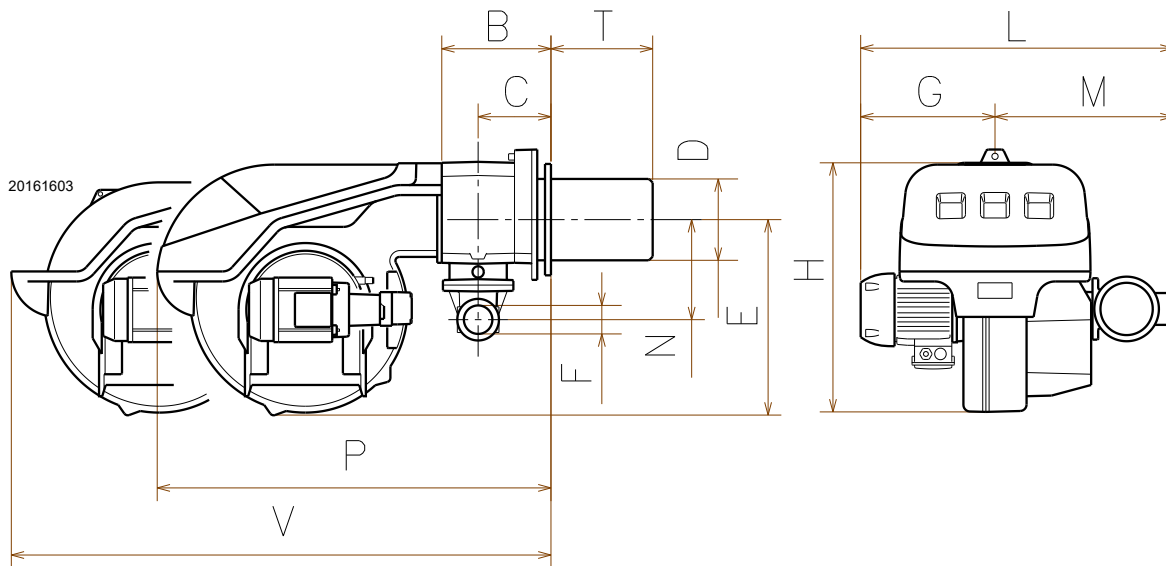

Fig. 2

Model	B	C	D	E	F	G	H	L	M	N	P	T	V
RLS 190/E	9 ³ / ₄ "	6"	8 ³ / ₄ "	16 ¹⁵ / ₁₆ "	ANSI 3"	16 ⁴⁹ / ₆₄ "	25 ¹³ / ₆₄ "	37 ¹³ / ₃₂ "	18 ²⁵ / ₃₂ "	8 ²³ / ₃₂ "	41 ¹³ / ₃₂ "	16 ⁷ / ₃₂ "	54"

Tab. E

3.6 Firing rate

MAXIMUM OUTPUT must be selected in area **A** (Fig. 3).

MINIMUM OUTPUT must not be lower than the minimum limit shown in the diagram.

Model	MBtu/hr	GPH
RLS 190/E	1880	14.7



WARNING

The FIRING RATE area values have been obtained considering an ambient temperature of 68 °F, and an atmospheric pressure of 394" WC and with the combustion head adjusted as shown on page 34.

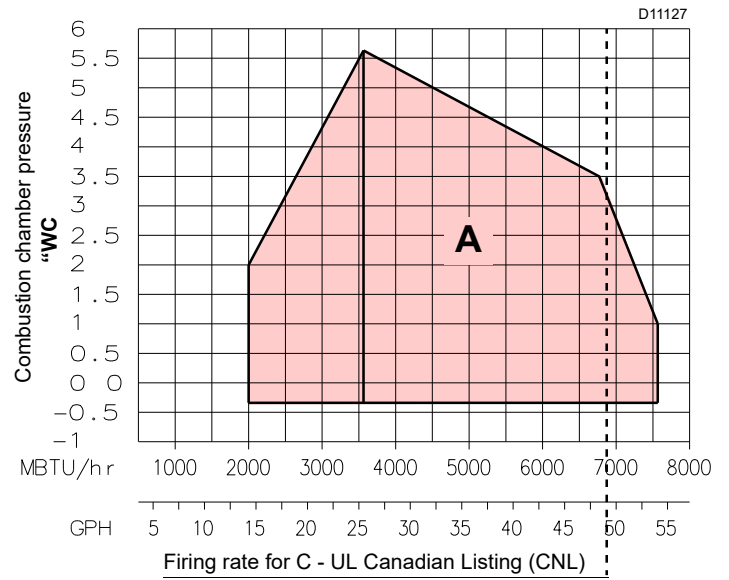

Fig. 3

3.6.1 Procedure to refer burner operating condition at an altitude and/or at a combustion supporter air temperature different to the standard values (328 ft above sea level, 68 °F)

AIR TEMPERATURE

Altitude	Altitude	bar. press.	bar. press.	0	5	10	15	20	25	30	40	°C
ft a.s.l.	m a.s.l.	"w.c.	mbar	32	41	50	59	68	77	86	104	°F
0	0	399	1013,00	1,087	1,068	1,049	1,031	1,013	0,996	0,980	0,948	
328	100	394	1000,00	1,073	1,054	1,035	1,017	1,000	0,983	0,967	0,936	
1.000	305	385	977,40	1,049	1,030	1,012	0,994	0,977	0,961	0,945	0,915	
2.000	610	371	942,80	1,012	0,994	0,976	0,959	0,943	0,927	0,912	0,883	
3.000	915	358	908,20	0,975	0,957	0,940	0,924	0,908	0,893	0,878	0,850	
4.000	1.220	345	875,80	0,940	0,923	0,907	0,891	0,876	0,861	0,847	0,820	
5.000	1.525	332	843,50	0,905	0,889	0,873	0,858	0,844	0,829	0,816	0,790	
6.000	1.830	320	811,85	0,871	0,856	0,841	0,826	0,812	0,798	0,785	0,760	
7.000	2.135	307	779,80	0,837	0,822	0,807	0,793	0,780	0,767	0,754	0,730	
8.000	2.440	294	747,80	0,803	0,788	0,774	0,761	0,748	0,735	0,723	0,700	

Tab. F

F - correction factor of discharge head and delivery in relation to temperature and altitude.

Reference conditions:

- Air temperature 68 °F (20 °C)
- Barometric pressure 394 "w.c. (1000 mbar)
- Altitude 328 ft a.s.l. (100 m a.s.l.)

Example

Using the , for an altitude of 3,000 ft and an air temperature of 68 °F, an **F** factor value is obtained equal to 0.908; if the capacity at the boiler furnace is $Q_{foc} = 4,500$ Mbtu/h, the correct output will be equal to:

$$Q_{burner} = Q_{foc} / F = 4,500 / 0.908 = 4,956 \text{ Mbtu/h}$$

3.7 Minimum furnace dimensions

The firing rates were set in relation to certified test boilers.

Fig. 4 indicates the diameter and length of the test combustion chamber.

Example

Output 2579 MBtu/hr: diameter 24 inch - length 6.6 ft.

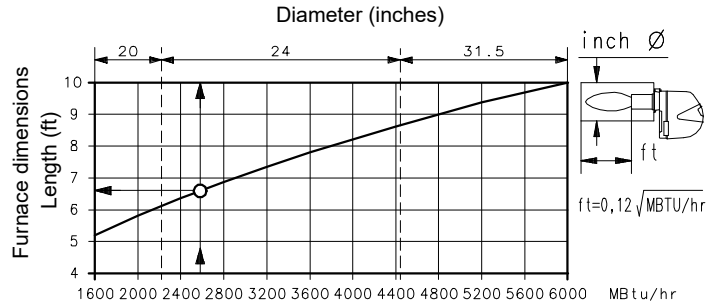

D2919

Fig. 4

3.8 Commercial boilers

The burner is suitable for operation on two or three flue passes commercial boilers.

The length of the blast tube must be selected according to the indications provided by the manufacturer of the boiler, and in any case it must be greater than the thickness of the boiler door complete with its refractory.

This protection must not compromise the extraction of the blast tube.

For boilers having a water-cooled front the refractory fettling is not required unless it is expressly requested by the boiler manufacturer.

The maximum thickness of the boiler's front door must not exceed 16" (Fig. 5).

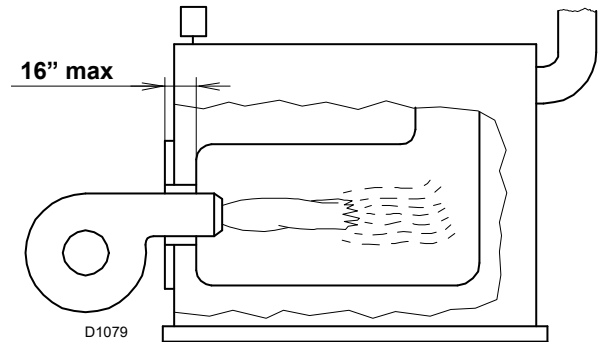

D1079

Fig. 5

3.9 Standard equipment

- Gas train flange No. 1
- Flange gasket. No. 1
- Flange fixing screws. No. 4
- Adaptor G 1/4" / 1/4" NPT No. 1
- Seal for adaptor No. 1
- Connector for adaptor No. 1
- Circular sector No. 4
- Flexible oil line No. 2
- Adaptor for flexible oil line No. 4
- Instruction booklet No. 1

3.10 Burner description

- 1 Combustion head
- 2 Ignition electrodes
- 3 Screw for combustion head adjustment
- 4 Sleeve
- 5 Fan motor
- 6 RWF55 modulator (with analog output 4-20 mA)
- 7 Pump motor contactor and thermal relay with reset button
- 8 Flame sensor
- 9 Burner terminal strip "X1"
- 10 Holes for cables grommets for electrical wirings, accessories and power supply (to be carried out by the installer)
- 11 Control box for checking flame and air/fuel ratio
- 12 Operator panel with LCD display
- 13 Flame inspection window
- 14 Low air pressure switch (differential operating type)
- 15 Slide bars for opening the burner and inspecting the combustion head
- 16 Safety oil solenoid valve
- 17 Valve assembly with pressure regulator on nozzle return
- 18 Gas pressure test point and head fixing screw
- 19 Air pressure test point
- 20 Air servomotor
- 21 Pump motor
- 22 Low oil pressure switch
- 23 Pilot attachment
- 24 Pump
- 25 Gas train flange
- 26 Boiler mounting flange
- 27 Flame stability disk
- 28 Screw securing fan to sleeve
- 29 Max. gas pressure switch
- 30 Ignition transformers "T2" (for gas operation)
- 31 Lifting rings and extension bars
- 32 Oil/gas actuator
- 33 High oil pressure switch
- 34 Ignition transformer "T1" (for oil operation)
- 35 Terminal strip for oil valve "X2"
- 36 Timer module and relay "KO1"
- 37 Timer module and relay "KG1"
- 38 "K3" relay
- 39 "K2" relay
- 40 "KG2" relay
- 41 "K5" relay
- 42 "K5" relay
- 43 Horn
- 44 Auxiliary fuse
- 45 "OFF - ON" switch
- 46 "LOCAL-REMOTE" switch
- 47 "ALARM SILENCE" button
- 48 "OIL - OFF - GAS" switch
- 49 "POWER ON" signal
- 50 "CALL FOR HEAT" signal
- 51 "ALARM ON" signal
- 52 "IGNITION ON" signal
- 53 "FUEL ON" signal
- 54 Optional holes
- 55 Ground terminals
- 56 Fan motor contactor and thermal relay with reset button
- 57 Delivery oil solenoid valve
- 58 Return oil solenoid valve
- 59 DIN bar for fuse holder step-down transformer and OCI 412.10
- 60 Anchor plate for installation of step-down transformer

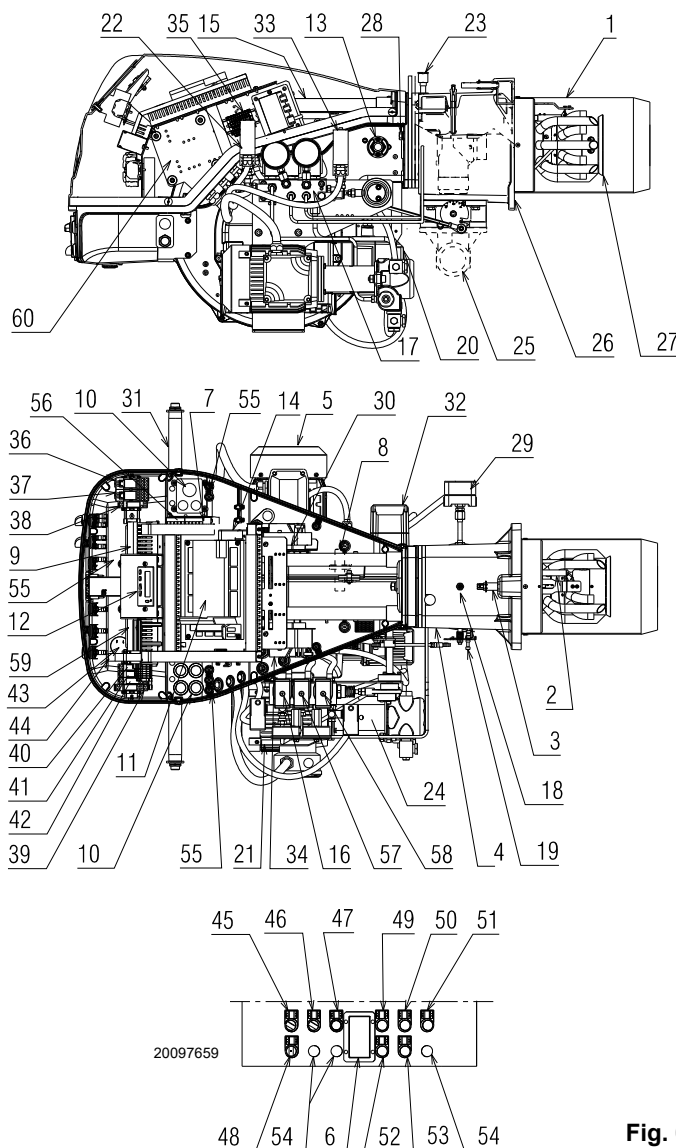

Fig. 6

Three types of burner failure may occur:

- **Flame safeguard lock-out**
If the flame safeguard alarm 51)(Fig. 6) lights up, it indicates that the burner is in lock-out. To reset, press the reset push-button.
- **Fan motor trip**
release by pressing the pushbutton on thermal overload 7)(Fig. 6). See "Overload relay and motor protector calibration" on page 31.
- **Pump motor trip**
release by pressing the pushbutton on thermal overload 56)(Fig. 6). See "Overload relay and motor protector calibration" on page 31.



For the installation and the adjustment of the high fire switch please refer to the specific manual of the device.

3.11 Control box for the air/fuel ratio (LMV36...)

Warning notes



WARNING

To avoid injury to persons, damage to property or the environment, the following warning notes must be observed!

The LMV36... is a safety device!

Do not open, interfere with or modify the unit.

The manufacturer will not assume responsibility for any damage resulting from unauthorized interference!

- All activities (mounting, installation and service work, etc.) must be performed by qualified staff.
- Before making any wiring changes in the connection area, completely isolate the plant from mains supply (all-polar disconnection). Ensure that the plant cannot be inadvertently switched on again and that it is indeed dead. If not observed, there is a risk of electric shock hazard.
- Ensure protection against electric shock hazard by providing adequate protection for the burner control's connection terminals.
- Each time work has been carried out (mounting, installation, service work, etc.), check to ensure that wiring and parameters is in an orderly state.
- Fall or shock can adversely affect the safety functions. Such units must not be put into operation, even if they do not exhibit any damage.

Introduction

The control box for the air/fuel ratio (Fig. 7), (hereafter referred to simply as the control box), that equips the burners, carries out a series of integrated functions in order to optimise burner functioning, both for single operation and together with other units (e.g. double furnace boiler or more than one generator at the same time).

The basic functions carried out by the control box relate to:

- flame control;
- the dosage of air and fuel via the positioning (with direct servo-control) of the relative valves, excluding the possible play in the mechanical cam calibration systems;
- the modulation of burner output, on the basis of the load requested by the system, maintaining the pressure or temperature of the boiler at the working values set;
- the safety diagnostic of the air and fuel circuits, via which it is possible to easily identify any causes of malfunctioning.

Mechanical design

The following system components are integrated in the LMV36... basic unit:

- Burner control with gas valve proving system
- Electronic air / fuel ratio control
- Control frequency converter air fan
- Modbus interface

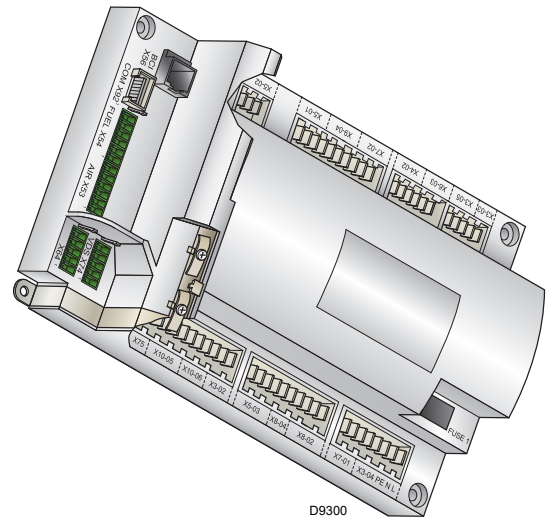

Fig. 7

Installation notes

- Always run high-voltage ignition cables separately while observing the greatest possible distance to the unit and to other cables.
- Do not mix up live and neutral conductors (fire hazard, dangerous failures, loss of protection against electric shock hazard, etc.).
- Do not lay the connecting cable from the LMV36... to the AZL2... together with other cables.



WARNING

The first start-up, like every further operation for the internal settings of the control box, requires access by means of a password and is only to be carried out by personnel of the Technical Assistance Service who have been specifically trained in the internal programming of the tool.

Electrical connection of the flame detectors

It is important to achieve practically disturbance- and loss-free signal transmission:

- Never run the detector cable together with other cables.
 - Line capacitance reduces the magnitude of the flame signal.
 - Use a separate cable.
- Observe the maximum permissible detector cable lengths.
- The ionization probe is not protected against electric shock hazard. It is mainspowered and must be protected against accidental contact.
- Locate the ignition electrode and the ionization probe such that the ignition spark cannot arc over to the ionization probe (risk of electrical overloads).

Technical data

LMV36... basic unit	Mains voltage	AC 120 V -15 % / +10 %	
	Mains frequency	50 / 60 Hz \pm 6 %	
	Power consumption	< 30 W (typically)	
	Safety class	I, with parts according to II and III to DIN EN 60730-1	
Terminal loading 'Inputs'	Unit fuse F1 (internally)	6.3 AT	
	Perm. mains primary fuse (externally)	Max. 16 AT	
	Undervoltage		
	<ul style="list-style-type: none"> • Safety shutdown from operating position at mains voltage • Restart on rise in mains voltage 	Approx. AC 93 V Approx. AC 96 V	
Terminal loading 'Outputs'	Total contact loading:		
	<ul style="list-style-type: none"> • Nominal voltage • Unit input current (safety loop) from: <ul style="list-style-type: none"> - Fan motor contactor - Ignition transformer - Valves - Oil pump / magnetic clutch 	AC 120 V, 50 / 60 Hz Max. 5 A	
	Individual contact loading:		
	Fan motor contactor		
	<ul style="list-style-type: none"> • Nominal voltage • Nominal current • Power factor 	AC 120 V, 50 / 60 Hz 1.6 A pilot duty load declaration to UL372 $\cos\phi > 0.4$	
	Alarm output		
	<ul style="list-style-type: none"> • Nominal voltage • Nominal current • Power factor 	AC 120 V, 50 / 60 Hz 1 A $\cos\phi > 0.4$	
	Ignition transformer		
	<ul style="list-style-type: none"> • Nominal voltage • Nominal current • Power factor 	AC 120 V, 50 / 60 Hz 1.6 A pilot duty load declaration to UL372 or 250 VA ignition load declaration to UL372 $\cos\phi > 0.2$	
	Fuel valves		
	<ul style="list-style-type: none"> • Nominal voltage • Nominal current • Power factor 	AC 120 V, 50 / 60 Hz 1.6 A pilot duty load declaration to UL372 $\cos\phi > 0.4$	
	Operation display		
	<ul style="list-style-type: none"> • Nominal voltage • Nominal current • Power factor 	AC 120 V, 50 / 60 Hz 0.5 A $\cos\phi > 0.4$	
	Cable lengths	Mains line	Max. 100 m (100 pF/m)
		Display, BCI	For used outside the burner cover or the control panel: Max. 3 m (100 pF/m)
	External lockout reset button	Max. 20 m (100 pF/m)	
Environmental conditions	Operation	DIN EN 60721-3-3	
	Climatic conditions	Class 3K3	
	Mechanical conditions	Class 3M3	
	Temperature range	-20...+60 °C	
	Humidity	< 95 % r.h.	

Tab. G

Operation sequence of the burner

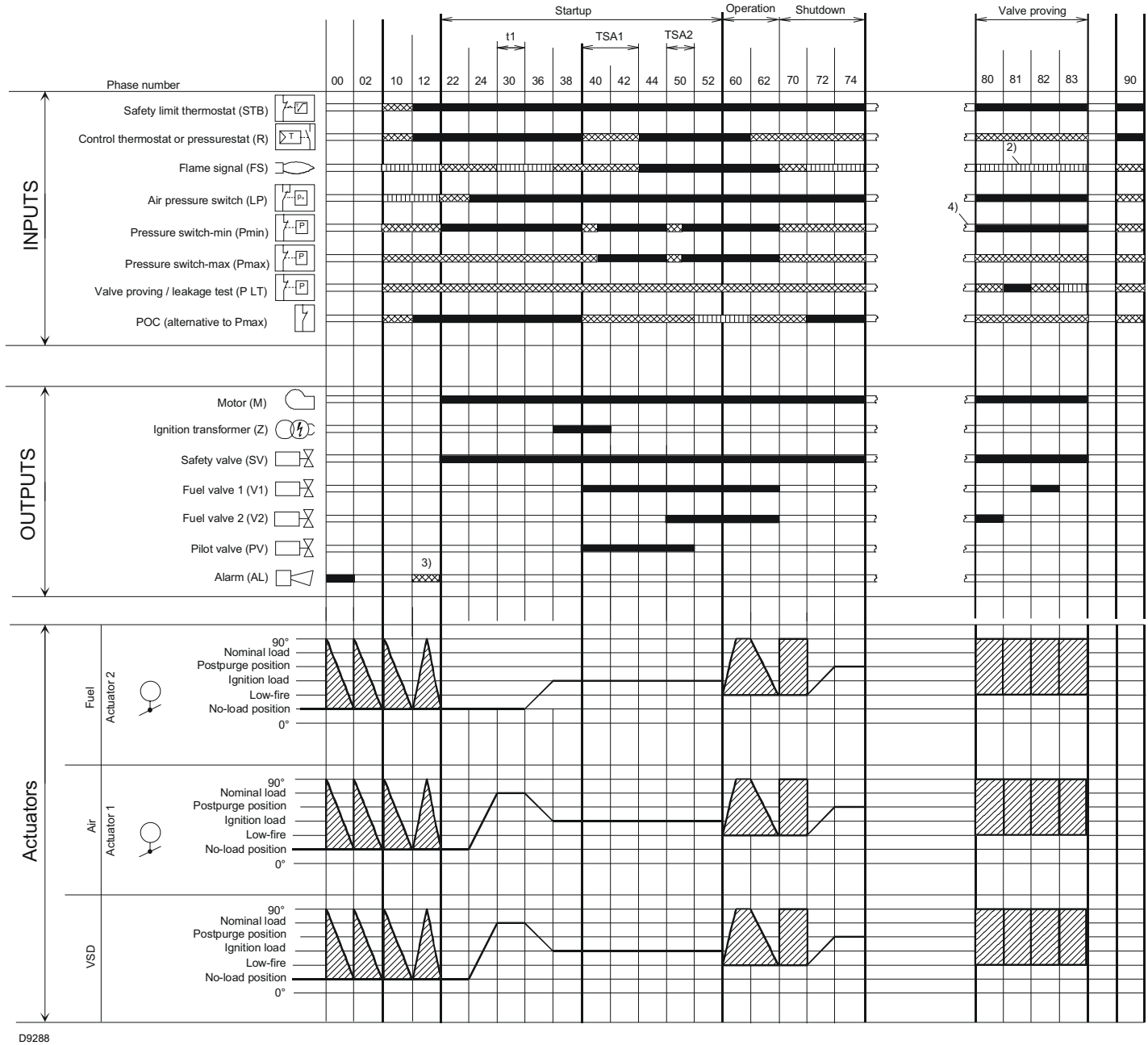

Fig. 8

Legend to the sequence diagrams:

Valve proving takes place depending on the parameter:

- 2) Only with valve proving on start-up
- 3) Parameter: with/without alarm in the event of start prevention
- 4) In the event of an erroneous signal on start-up, followed by phase 10, otherwise phase 70

- 0° Position as supplied (0°)
- 90° Actuator fully open (90°)

- Signal ON
- Signal OFF
- Any signal is allowed



In standby: after referencing, the actuator is driven to the no-load position

Assignment of times:

- t1** Prepurgation time
- TSA1** Safety time 1 gas / oil
- TSA2** Safety time 2 gas / oil

3.12 Actuators (SQM33.5...)

Warning notes



WARNING

To avoid injury to persons, damage to property or the environment, the following warning notes should be observed!

Do not open, interfere with or modify the actuators!

- All activities (mounting, installation and service work, etc.) must be performed by qualified staff.
- Before making any wiring changes in the connection area of the units, completely isolate the equipment from mains supply (all-polar disconnection). If not observed, there is a risk of electric shock hazard.
- Ensure protection against electric shock hazard by providing adequate protection for the connection terminals and by securing the housing cover.
- After any kind of activity (mounting, installation and service work, etc.), check wiring.
Also ensure that the parameters are correctly set.
- Fall or shock can adversely affect the safety functions. Such units must not be put into operation, even if they do not exhibit any damage.



WARNING

The actuator's housing must not be opened. The actuator contains an optical feedback system.

Use

The actuators (Fig. 9) are used to drive and position the air damper and the gas butterfly valve, without mechanical leverages but via the interposition of an elastic coupling.

They are commanded by the control box, which constantly checks their position by means of a return signal from the optic sensor inside the actuator.

The position (in degrees) of the actuators can be seen on the display of the Operator Panel.

Index "0" for fuel actuator, index "1" for air actuator.

Installation notes

- Always run the high-voltage ignition cables separate from the unit and other cables while observing the greatest possible distance.
- The holding torque is reduced when the actuator is disconnected from power.



WARNING

When servicing or replacing the actuators, take care not to invert the connectors.

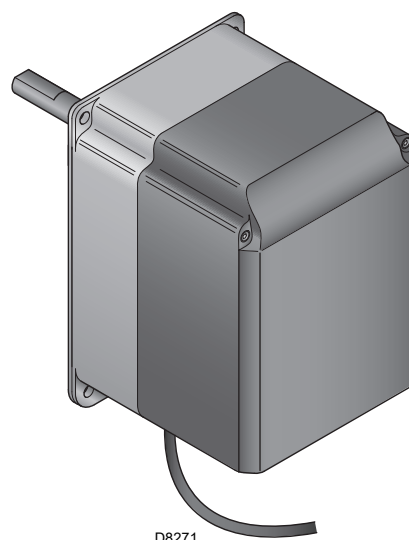

Fig. 9

Technical data

Operating voltage	AC / DC 24 V ±20 % (load on interface)
Safety class	2 to EN 60 730 part 1 and parts 2...14
Power consumption	max. 10 W
Degree of protection	IP54 to EN 60 529-1
Opening time 0 - 90°	min: 5s, max.: 120s (depending on the type of control box)
Firing rate	0 - 90°
Cable connection	RAST2,5 connectors
Direction of rotation	Clockwise/anticlockwise (can be selected from the control box)
Nominal output torque	3 Nm
Holding torque (when live)	3 Nm
Holding torque (when dead)	2.6 Nm
Weight	approx. 1 kg
Environmental conditions:	
Operation	DIN EN 60 721-3-3
Climatic conditions	class 3K5
Mechanical conditions	class 3M4
Temperature range	-20...+ 60 °C
Humidity	< 95 % r.h.

Tab. H

4

Installation

4.1 Notes on safety for the installation

After carefully cleaning all around the area where the burner will be installed, and arranging the correct lighting of the environment, proceed with the installation operations.



All the installation, maintenance and disassembly operations must be carried out with the electricity supply disconnected.



The installation of the burner must be carried out by qualified personnel, as indicated in this manual and in compliance with the standards and regulations of the laws in force.



Combustion air inside the boiler must be free from hazardous mixes (e.g.: chloride, fluoride, halogen); if present, it is highly recommended to carry out cleaning and maintenance more frequently.

4.2 Handling

The burner packaging includes a wooden platform, it is therefore possible to move the burner (still packaged) with a transpallet truck or fork lift truck.



The handling operations for the burner can be highly dangerous if not carried out with the greatest attention: keep any unauthorised people at a distance; check the integrity and suitability of the available means of handling.

Check also that the area in which you are working is empty and that there is an adequate escape area (i.e. a free, safe area to which you can quickly move if the burner should fall).

When handling, keep the load at not more than 20-25cm from the ground.



After positioning the burner near the installation point, correctly dispose of all residual packaging, separating the various types of material.



Before proceeding with the installation operations, carefully clean all around the area where the burner will be installed.

4.3 Preliminary checks

Checking the consignment



After removing all the packaging, check the integrity of the contents. In the event of doubt, do not use the burner; contact the supplier.



The packaging elements (wooden cage or cardboard box, nails, clips, plastic bags, etc.) must not be abandoned as they are potential sources of danger and pollution; they should be collected and disposed of in the appropriate places.



The output of the burner must be within the boiler's firing rate;



A burner label that has been tampered with, removed or is missing, along with anything else that prevents the definite identification of the burner makes any installation or maintenance work difficult.

4.4 Burner raising

In order to lift the burner, proceed as follows:

- screw the two extension bars 1) on the pins 2)(Fig. 10);
- place the two plates 3) fix them on the relevant ring nuts 4);
- the four burner lifting points are indicated in Fig. 10.



The manufacturer declines any and every responsibility for any possible lifting movements, different from those indicated in this manual.

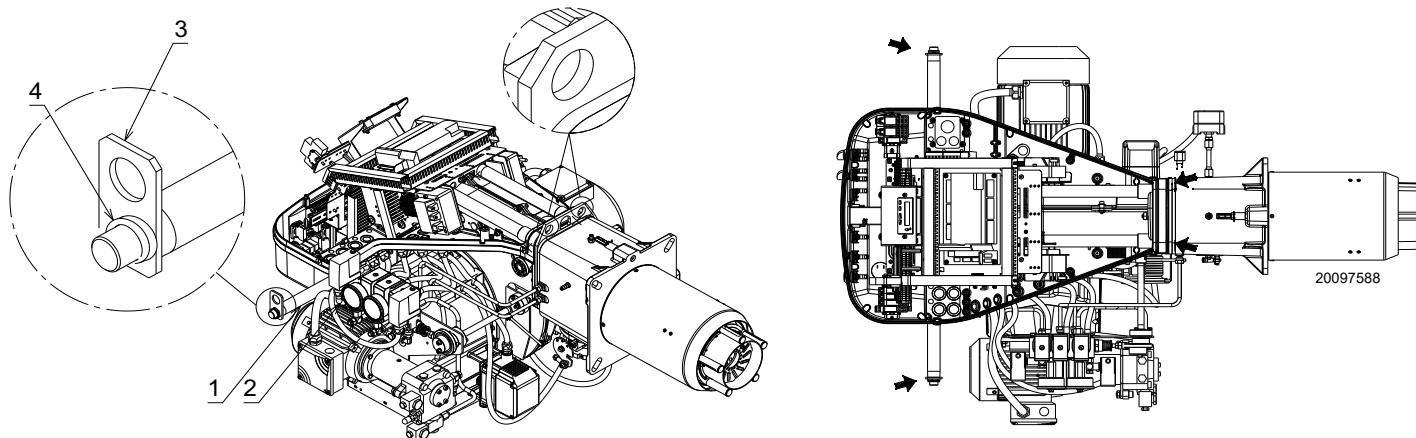

Fig. 10

4.5 Preparing the boiler

4.5.1 Boring the boiler plate

Drill the combustion chamber mounting plate as shown in Fig. 11. The position of the threaded holes can be marked using the gasket supplied with the burner.

4.5.2 Blast tube length

The length of the blast tube must be selected according to the indications provided by the manufacturer of the boiler, it must be greater than the thickness of the boiler door complete with its insulation. The range of lengths available, L (inch), is as follows:

Model	L	
RLS 190/E	16 ⁷ / ₃₂ "	short
	21 ¹¹ / ₃₂ "	long (with kit)

Tab. I

For boilers with front flue passes (13) or flame inversion chambers, insulation material (11) must be inserted between the refractory (12) and the blast tube (10).

This protective insulation must not compromise the extraction of the blast tube.

For boilers having a water-cooled front, the insulation (11)- (12)(Fig. 12, page 18) is not required unless it is required by the boiler manufacturer.

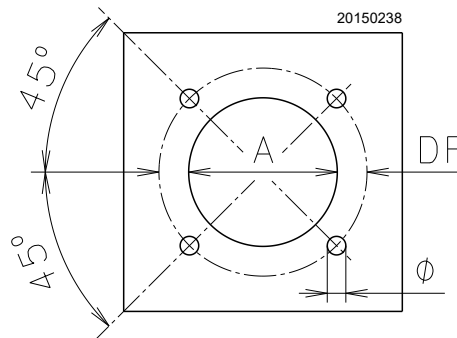

Fig. 11

	A	DF	Ø
inch	9 ¹ / ₁₆ "	12 ²⁵ / ₃₂ " - 14 ¹ / ₂ "	⁵ / ₈ W

Tab. J

4.6 Securing the burner to the boiler

Detach the combustion head from the burner, (Fig. 12):

- disconnect the oil pipes by unscrewing the two connectors 6);
- loosen the 4 screws 3) and remove the cover 1);
- disengage the swivel coupling 14) from the graduated sector;
- remove the screws 2) from the slide bars 5);
- remove the 2 screws 4) and pull the burner back on slide bars 5) by about 4";
- install the extension bars 31) Fig. 6, page 11 and re-screw the screws 2) including the safety plate 15);
- disconnect the electrode wires and then pull the burner completely off the slide bars.

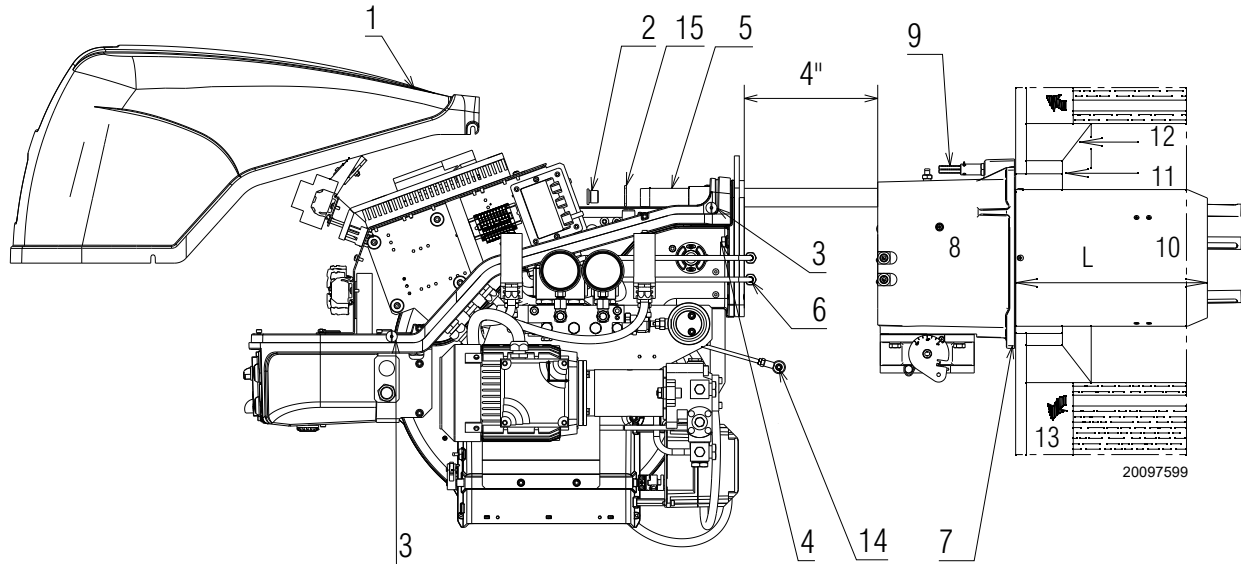

Fig. 12

4.7 Nozzle installation

The burner complies with the emission requirements of the UL 296 standard.

In order to guarantee that emissions do not vary, recommended and/or alternative nozzles specified by Riello in the Instruction and warning booklet should be used.



WARNING

It is advisable to replace nozzles every year during regular maintenance operations.



CAUTION

The use of nozzles other than those specified by the Manufacturer and inadequate regular maintenance may result into emission limits non-conforming to the values set forth by the regulations in force, and in extremely serious cases, into potential hazards to people and objects.

The manufacturing company shall not be liable for any such damage arising from nonobservance of the requirements contained in this manual.

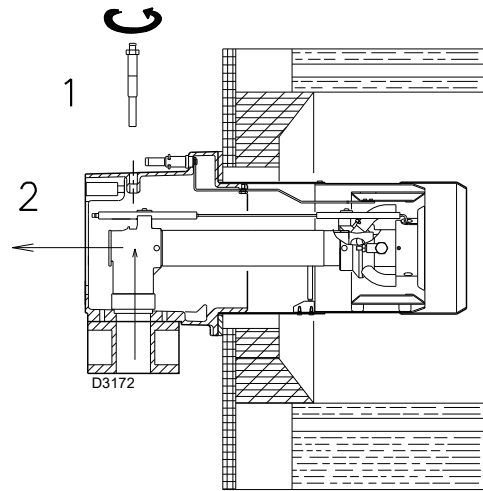

Fig. 13

Recommended nozzles

- BERGONZO A4 45°
- DELAVAN VARIFLO 45° and 60°
- FLUIDICS KC2 30° and 45°

4.7.1 Nozzle assembly

In order to assemble the nozzle, proceed as follows:

- remove screw 1)(Fig. 13) and extract the nozzle assembly 2);
- install the nozzle 1)(Fig. 14);
- fitting the wrench through the central hole in the flame stability disk or loosen screws 1)(Fig. 15);
- remove disk 2)(Fig. 15) and replace the nozzles using the wrench 3)(Fig. 15).



WARNING

- Do not use any sealing products such as gaskets, sealing compound, or tape.
- Be careful to avoid damaging the nozzle sealing seat.
- The nozzles must be screwed into place tightly but carefully.
- The nozzle for low fire operation is the one lying beneath the firing electrodes (Fig. 45).
- Make sure that the electrodes are positioned as shown in Fig. 45.

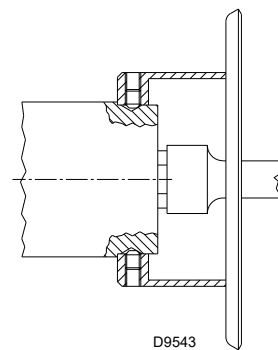

Fig. 14

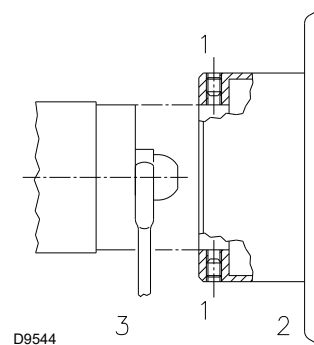

Fig. 15

4.7.2 Adjusting the nozzle flow rate

The nozzle flow rate varies according to the fuel pressure on the nozzle return.

Diagram (Fig. 17) indicates this relationship for type A4 return flow nozzles with pump delivery pressure of 290 PSI. See Fig. 17:

Horizontal axis: PSI, nozzle return pressure

Vertical axis: GPH, nozzle flow rate

The values indicated in the right side of the diagram (Fig. 17), refer to the data printed on the nozzle.

With a pump delivery pressure of 290 PSI, the pressure on the nozzle return must not exceed 246.5 PSI.

The pressure difference between pump delivery and nozzle return must be at least 43.5 PSI. With smaller pressure differences, the pressure on the nozzle return can be unstable.

The nozzle return pressure value is indicated by the pressure gauge 1)(Fig. 16).

The output and the pressure of the nozzle are at maximum when the servomotor is positioned on maximum.

The proper setting of the eccentric 6) is possible when its operation field follows the servomotor operation field (0° - 90°): so, that every variation of the servomotor position corresponds to a pressure variation.

If at the maximum capacity of the nozzle (maximum pressure in the return line) pressure fluctuations are detected on the gauge 1), slightly decrease the pressure in the return line until they are completely eliminated.

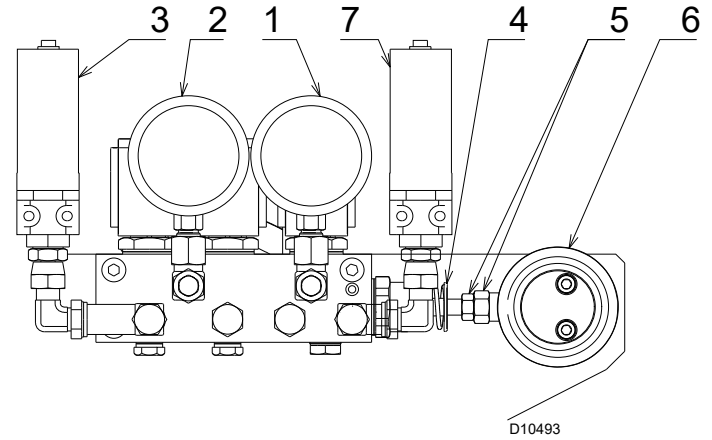

Fig. 16

- 1 Gauge for pressure in return line
- 2 Gauge for pressure in delivery line
- 3 Low oil pressure switch
- 4 Ring for piston stop
- 5 Nut and lock-nut for piston setting
- 6 Fixed eccentric
- 7 High oil pressure switch

Type A4 return flow nozzle (45°)

Delivery pressure 290 PSI

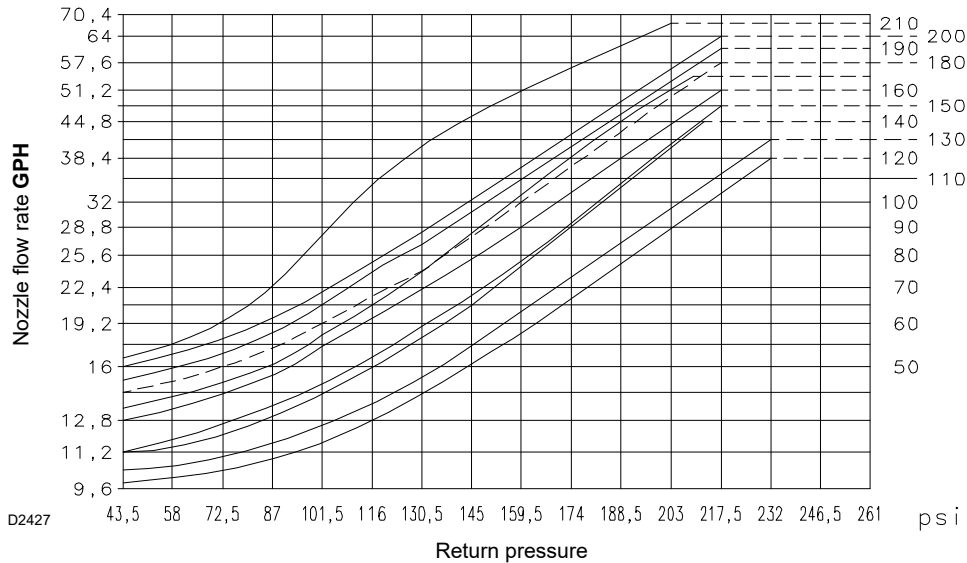
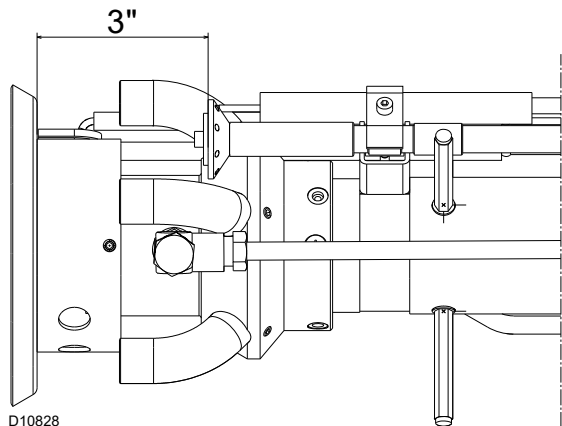

Fig. 17

The values indicated in the right side of the diagram (Fig. 17), refer to the data printed on the nozzle.

4.8 Ignition pilot adjustment

Place the pilot and electrode as shown in Fig. 18.
The pilot works correctly at pressures ranging from 6 - 12" WC.



D10828

Fig. 18

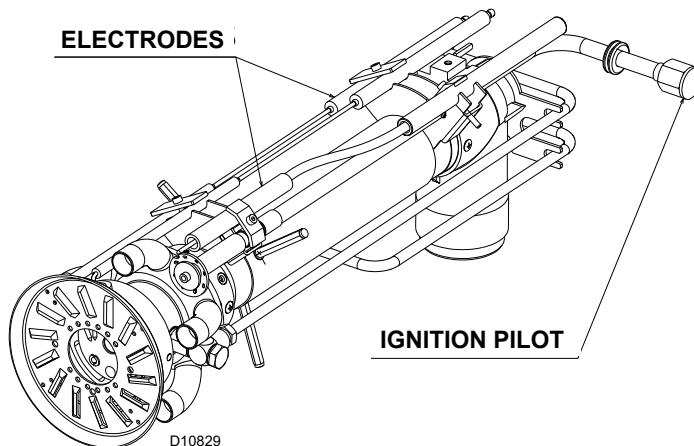

Fig. 19

4.9 Combustion head setting

The setting of the combustion head depends exclusively on the maximum delivery of the burner.

Turn screw 6 (Fig. 21) until the notch shown in diagram (Fig. 20) is level with the front surface of flange 5 (Fig. 21).

Example

maximum burner delivery = 7000 MBtu/hr.

If diagram (Fig. 20) is consulted it is clear that for this delivery, the combustion head must be adjusted using notch 10, as shown in Fig. 21.

In case of high altitude site, head setting must refer to the "corrected capacity" according procedure described at page 9.

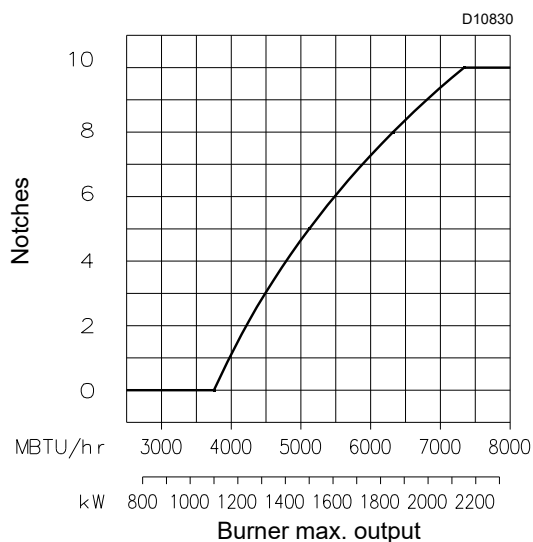

Fig. 20

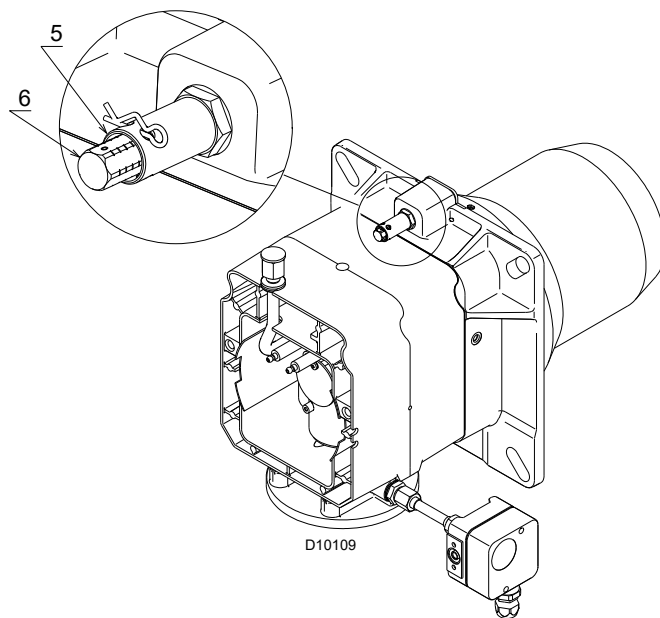

Fig. 21

4.10 Burner refitting

- Refit the burner to the slide bars 3)(Fig. 22) at approximately 4" from the sleeve 4) - burner positioned as shown in Fig. 12, page 18 - insert the ignition electrode cables;
- remove the extension bars 31)(Fig. 6, page 11);
- slide the burner up to the sleeve so that it is positioned as shown in Fig. 22;
- refit screws 2)(Fig. 22) on slide bars 3) including the safety plate 15) Fig. 12, page 18;
- secure the burner to the sleeve by tightening screws 1);
- connect the oil pipes again by screwing on the two connectors 6)(Fig. 12, page 18).



When fitting the burner on the two slide bars, it is advisable to gently draw out the high tension cables until they are slightly stretched.

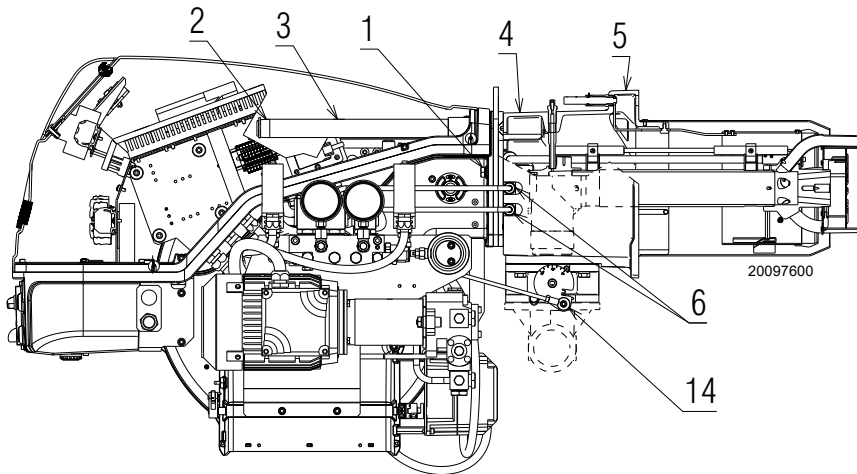

Fig. 22

4.11 Light oil supply



Explosion danger due to fuel leaks in the presence of a flammable source.

Precautions: avoid knocking, attrition, sparks and heat.

Make sure the fuel interception tap is closed before performing any operation on the burner.



WARNING

The fuel supply line must be installed by qualified personnel, in compliance with current standards and laws.

4.11.1 Fuel supply

Double-pipe circuit (Fig. 23)

The burner is equipped with a self-priming pump which is capable of feeding itself within the limits listed in the table at the side.

The tank higher than the burner A

Distance "P" must not exceed 33 ft in order to avoid subjecting the pump's seal to excessive strain; distance "V" must not exceed 13 ft in order to permit pump self-priming even when the tank is almost completely empty.

The tank lower than the burner B

Pump suction values higher than 13 ft must not be exceeded because at higher levels gas is released from the fuel, the pump starts making noise and its working life-span decreases.

It is good practice to ensure that the return and suction lines enter the burner from the same height; in this way it will be less probable that the suction line fails to prime or stops priming.

The loop circuit

A loop circuit consists of a loop of piping exiting and returning to the tank with an auxiliary pump that circulates the fuel under pressure.

A branch connection from the loop goes to feed the burner.

This circuit is extremely useful whenever the burner pump does not succeed in self-priming because the tank distance and/or height difference are higher than the values listed in the table below.

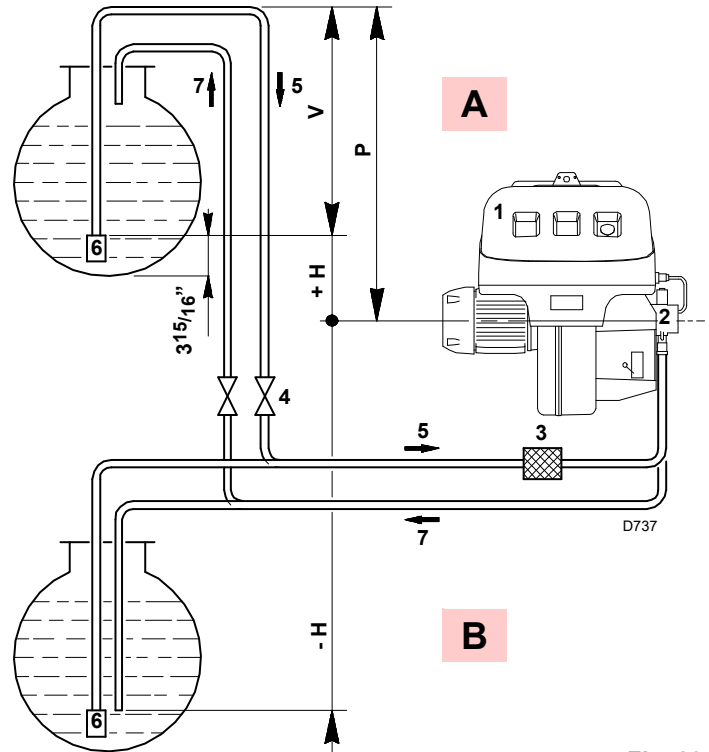

Fig. 23

- 1 Burner
- 2 Pump
- 3 Filter
- 4 Manual on/off valve
- 5 Suction line
- 6 Foot valve
- 7 Return line
- V Max distance 13 ft
- H Pump/foot valve height difference
- L Piping length
- Ø Inside pipe diameter

+/- H (ft)	L (ft)	
	Ø 1/2"	Ø 5/8"
+ 13	197	263
+ 10	164	230
+ 6.6	132	197
+ 4.8	115	181
+ 3.3	99	164
+ 1.6	82	148
0	66	132
- 1.6	59	115
- 3.3	49	99
- 4.8	43	82
- 6.6	33	66
- 10	16	33
- 13	-	20

Tab. K

4.11.2 Hydraulic connections

The pumps are equipped with a by-pass that separates return line with suction line (Fig. 24).

The pumps are installed on the burner with the by-pass closed by screw 6)(Fig. 25).

It is therefore necessary to connect both hoses to the pump.



WARNING

The pump seal will be damaged immediately if it is run with the return line closed and the by-pass screw inserted.

Remove the plugs from the suction and return connections of the pump.

Insert the hose connections with the supplied seals into the connections and screw them down.

Take care that the hoses are not stretched or twisted during installation.

Install the hoses where they cannot be stepped on or come into contact with hot surfaces of the boiler.

Now connect the other end of the hoses to the suction and return lines.

4.11.3 Pump

Pump model TA2

Min. delivery rate at 290 PSI pressure	GPH	150
Delivery pressure range	PSI	102 - 580
Max. suction pressure	"Hg	13
Viscosity range	cSt	4 - 800
Max. light oil temperature	°F	284 (140 °C)
Max. suction and return pressure	PSI	72.5
Pressure calibration in the factory	PSI	360

Tab. L

4.11.4 Pump priming



WARNING

Before starting the burner, make sure that the tank return line is not clogged.

Obstructions in the line could cause the seal located on the pump shaft to break.

The time required for this operation depends upon the diameter and length of the suction tubing.

If the pump fails to prime at the first starting of the burner and the burner locks out, wait approx. 15 seconds, reset the burner, and then repeat the starting operation as often as required.

After 5 or 6 starting operations allow 2 or 3 minutes for the transformer to cool.



WARNING

The priming operation is possible because the pump is already full of fuel when it leaves the factory. If the pump has been drained, fill it with fuel through the opening on the vacuum meter prior to starting; otherwise, the pump will seize.

Whenever the length of the suction piping exceeds 66 - 98 ft, the supply line must be filled using a separate pump.

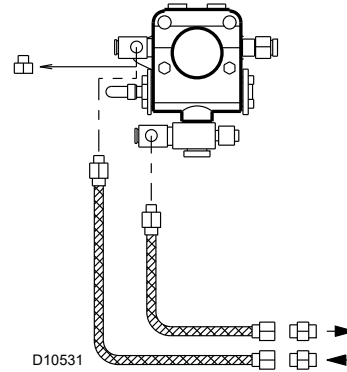

Fig. 24

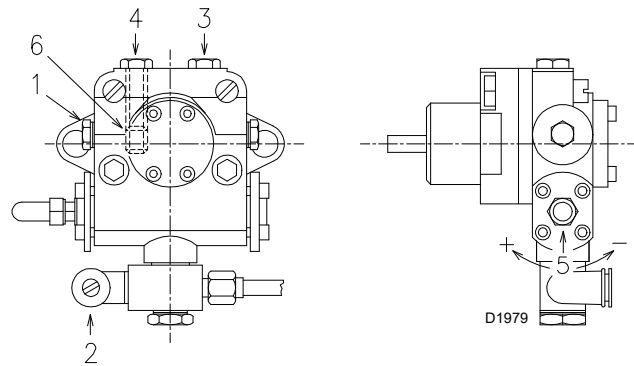

Fig. 25

Key (Fig. 25)

- | | | |
|---|---------------------------|----------|
| 1 | Suction | 1/2" NPT |
| 2 | Return | 1/2" NPT |
| 3 | Pressure gauge attachment | G 1/4" |
| 4 | Vacuum gauge attachment | G 1/4" |
| 5 | Pressure adjustment screw | |
| 6 | By-pass screw | |

4.12 Gas feeding



Explosion danger due to fuel leaks in the presence of a flammable source.

Precautions: avoid knocking, attrition, sparks and heat.

Make sure the fuel interception tap is closed before performing any operation on the burner.



WARNING

The fuel supply line must be installed by qualified personnel, in compliance with current standards and laws.

The main gas train must be connected to the gas attachment 1)(Fig. 26), using flange 2), gasket 3) and screws 4) supplied with the burner.

The main gas train can enter the burner from the right or left side, see Fig. 26.

Gas safety shut-off valves 5)-6)(Fig. 27) must be as close as possible to the burner to ensure gas reaches the combustion head within the safety time range.

The pilot gas train must be connected to the gas attachment 5)(Fig. 26) and can enter the burner from the right or left side.

4.12.1 Gas train

It must be type-approved according to UL Standards and is supplied separately from the burner.



WARNING

See the accompanying instructions for the adjustment of the gas train.



Check that there are no gas leaks.



Pay attention when handling the train: danger of crushing of limbs.



Make sure that the gas train is properly installed by checking for any fuel leaks.



The operator must use the required equipment during installation.

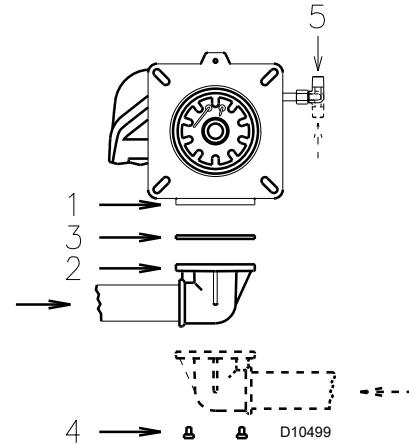

Fig. 26

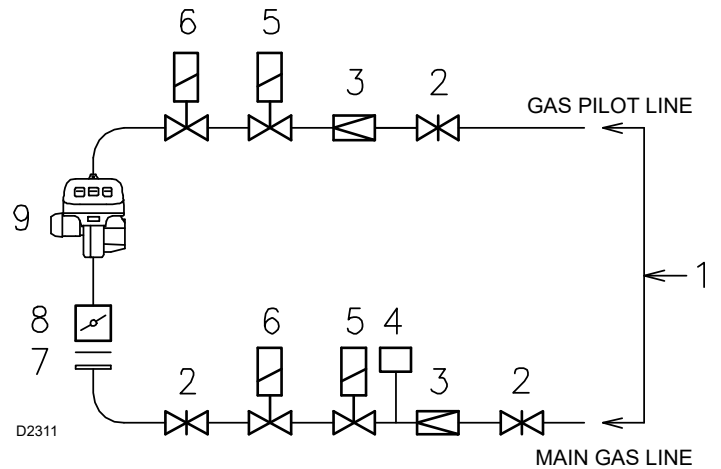

Fig. 27

Key (Fig. 27)

- 1 Gas input pipe
- 2 Manual valve
- 3 Pressure regulator
- 4 Low gas pressure switch
- 5 1st safety shut off valve
- 6 2nd safety shut off valve
- 7 Standard issue burner gasket with flange
- 8 Gas butterfly valve
- 9 Burner

4.12.2 Gas valve electrical connections



Connections must be respected.



Pay attention to the terminals during the connection of the valves.
The correct terminals are the orange ones, as shown in Fig. 29-A.

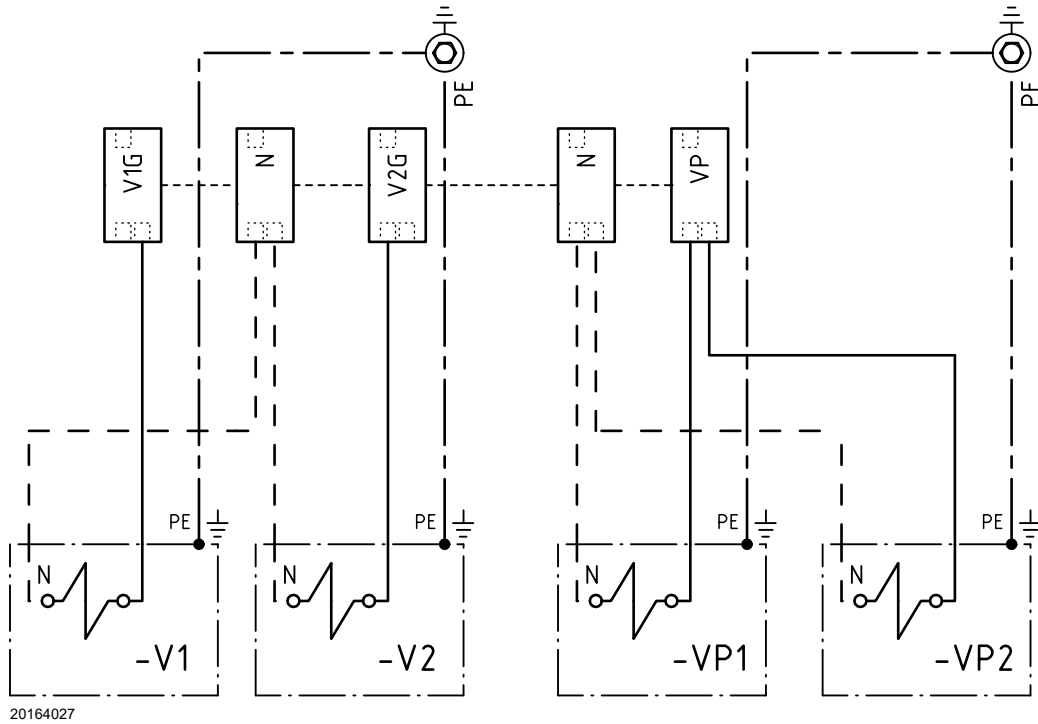

20164027

Fig. 28

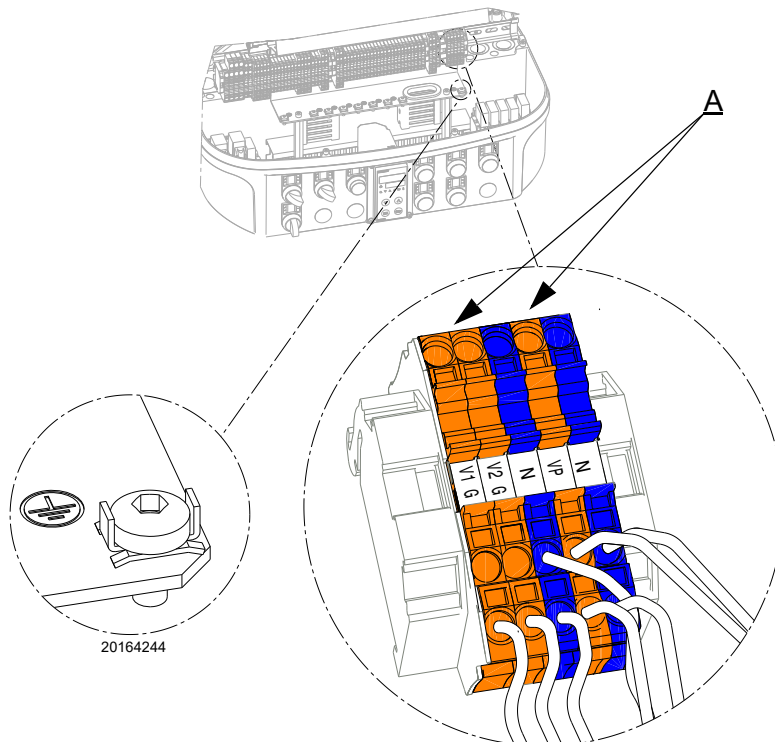

20164244

Fig. 29



In case of installation of the vent valves (VV and VV1), the configuration will be that shown in Fig. 30.

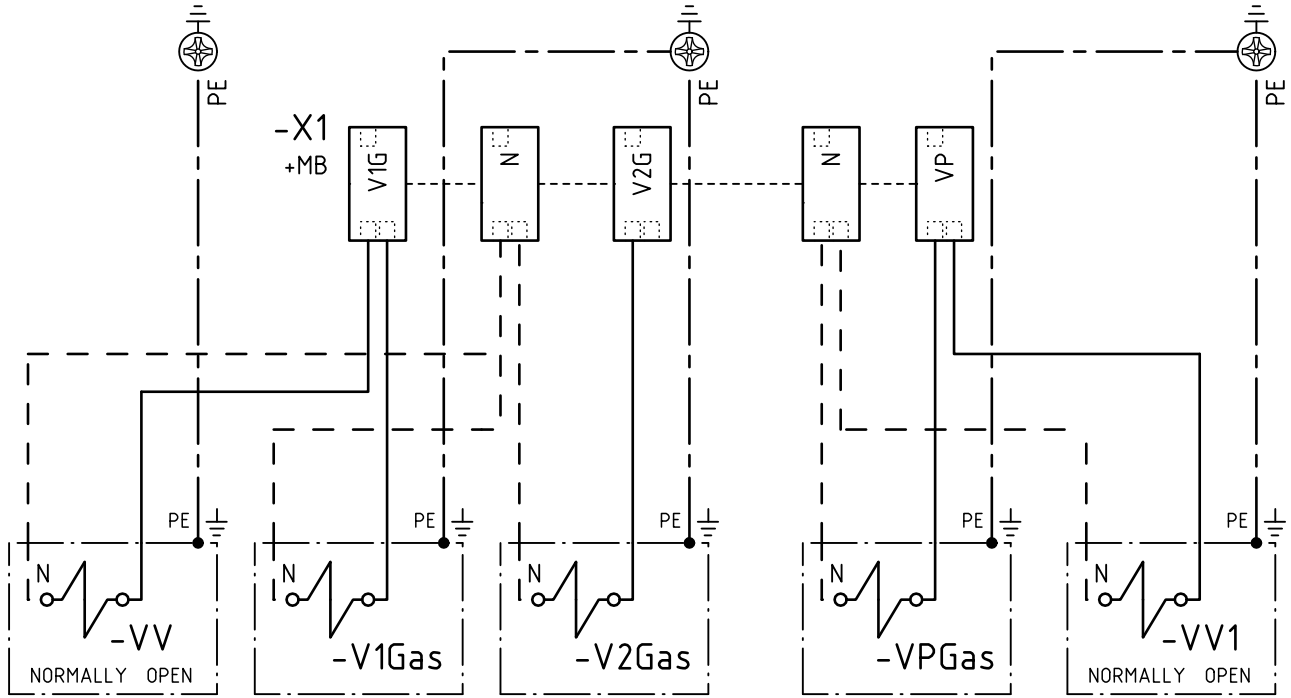

20183903

Fig. 30

4.12.3 Gas pressure

The adjacent diagrams are used to calculate manifold pressure taking into account combustion chamber pressure.

Gas manifold pressure measured at test point 1)(Fig. 32), with:

- combustion chamber at 0" WC
- burner operating at maximum output
- combustion head adjusted as indicated in diagram (Fig. 20)

Calculate the approximate high fire output of the burner as follows:

- subtract the combustion chamber pressure from the gas pressure measured at test point 1)(Fig. 32).
- Find the nearest pressure value to your result in Fig. 31.
- Read off the corresponding output on the left.

Example

- Maximum output operation
- Natural gas
- Gas pressure at test point 1)(Fig. 32) = 8.0" WC
- Pressure in combustion chamber = 1.2" WC
- 8.0 - 1.2 = 6.8" WC

A maximum output of 6500 MBtu/hr shown in diagram corresponds to 6.8" WC pressure.

This value serves as a rough guide, the effective delivery must be measured at the gas meter.

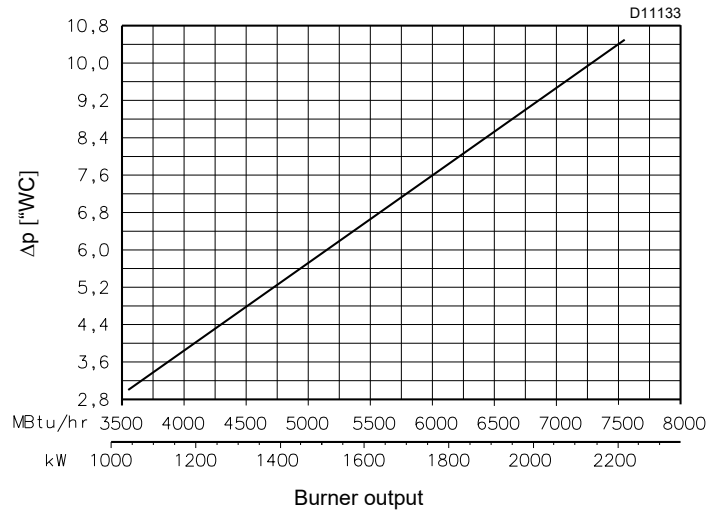

Fig. 31

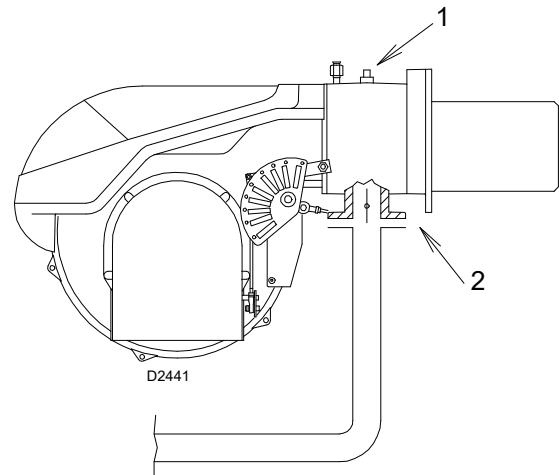

Fig. 32

MBtu/hr	kW	Δp ("WC)	
		1	2*
3553	1100	3.04	0.4
4095	1200	4.00	0.6
4435	1300	4.60	0.7
4775	1400	5.20	0.8
5120	1500	5.90	0.9
5460	1600	6.60	1.0
5800	1700	7.40	1.1
6140	1800	7.80	1.2
6480	1900	8.04	1.3
6874	2000	9.42	1.3
7560	2150	10.50	1.5

* The values are referred to the butterfly gas valve.



The data of thermal output and combustion head gas pressure are related to full open (90°) gas butterfly valve.

4.13 Electrical wiring

Notes on safety for the electrical wiring



DANGER

- The electrical wiring must be carried out with the electrical supply disconnected.
- Electrical wiring must be carried out by qualified personnel and in compliance with the regulations currently in force in the country of destination. Refer to the electrical layouts.
- The manufacturer declines all responsibility for modifications or connections different from those shown in the electrical layouts.
- Check that the electrical supply of the burner corresponds to that shown on the identification label and in this manual.
- Do not invert the neutral with the phase in the electrical supply line. Any inversion would cause a lockout due to firing failure.
- The electrical safety of the device is obtained only when it is correctly connected to an efficient earthing system, made according to current standards. It is necessary to check this fundamental safety requirement. In the event of doubt, have the electrical system checked by qualified personnel. Do not use the gas tubes as an earthing system for electrical devices.
- The electrical system must be suitable for the maximum input power of the device, as indicated on the label and in the manual, checking in particular that the section of the cables is suitable for the input power of the device.
- For the main power supply of the device from the electricity mains:
 - do not use adapters, multiple sockets or extensions;
 - use an omnipolar switch with an opening of at least $1/8$ " (overvoltage category) between the contacts, as indicated by the current safety standards.
- Do not touch the device with wet or damp body parts and/or in bare feet.
- Do not pull the electric cables.

Before carrying out any maintenance, cleaning or checking operations:



DANGER

Disconnect the electrical supply from the burner by means of the main system switch.



DANGER

Turn off the fuel interception tap.



DANGER

Avoid condensate, ice and water leaks from forming.

If the cover is still present, remove it and proceed with the electrical wiring.

4.13.1 Notes on terminals

On the electrical panel there terminals with a "spring" system. The opening of these terminals must be made via a suitable tool, using a flat-blade screwdriver of the correct size.

The clamp uses a pressurised opening system.

Clamp opening

- insert the correct screwdriver into the opening, pushing down until the hole for the cable is completely open.
- Insert the previously stripped cable and remove the screwdriver. Make sure the cable is securely fastened Fig. 33.

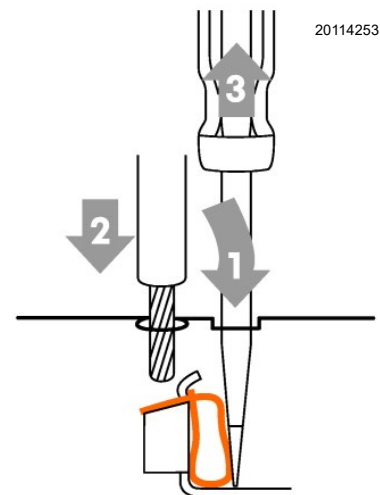

Fig. 33

4.13.2 Supply cables and external connections passage

All the cables to be connected to the burner are fed through the grommets. See figure on the right.

The use of the cable grommets can take various forms.

By way of example we indicate the following mode (according to **UL795**):

- 1 Three phase power supply with 3/4 inch cable grommet
- 2 Available: single phase power supply and other devices with 1/2 inch cable grommet
- 3 Available: consents/safety, minimum gas pressure switch, gas valves and other devices with 3/8 inch cable grommet
- 4 Available: hole for M16
- 5 Available for ground terminals

- A Fan motor
- B Maximum gas pressure switch
- C Flame sensor
- D Air servomotor
- E Fuel servomotor
- F Air pressure switch
- G Oil valve
- H Oil pressure switch
- I Pump motor

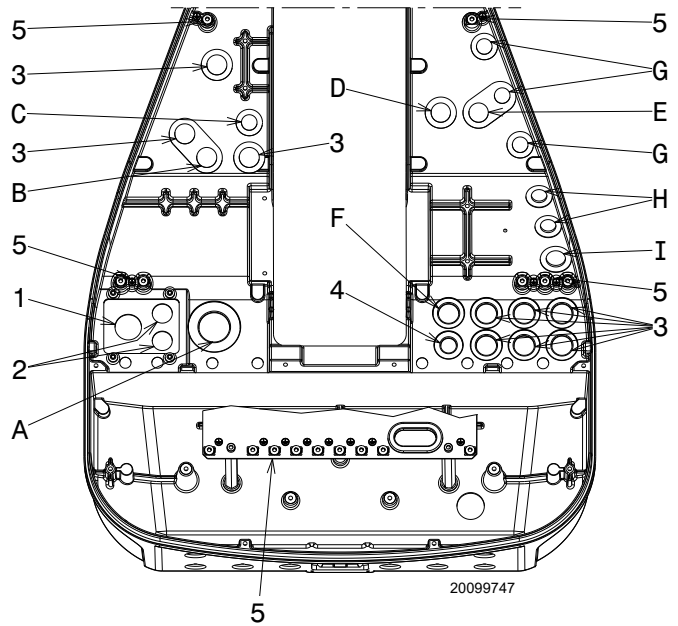

Fig. 34



WARNING

The control panel is in compliance with UL508A.



After carrying out maintenance, cleaning or checking operations, reassemble the hood and all the safety and protection devices of the burner.

4.14 Overload relay and motor protector calibration

Depending on the burner type, there are two different overload relays:

- electro-mechanical overload relay (used for single phase motors);
- electronic relay (used for three phase motors)
- motor protector

4.14.1 Electro-mechanical overload relay

The electro-mechanical overload relay (Fig. 35) is used to avoid damage to the motor owing to a strong increase in absorption or the lack of a phase.

For the calibration, refer to the table given in electrical layout. If the minimum value of the scale of the overload relay is greater than the rating absorption of the motor, protection is still ensured.

- To reset, in the case of an intervention of the overload relay, press the button "RESET" (Fig. 35).
- The button "STOP" (Fig. 35) opens the NC (95-96) contact and stops the motor.

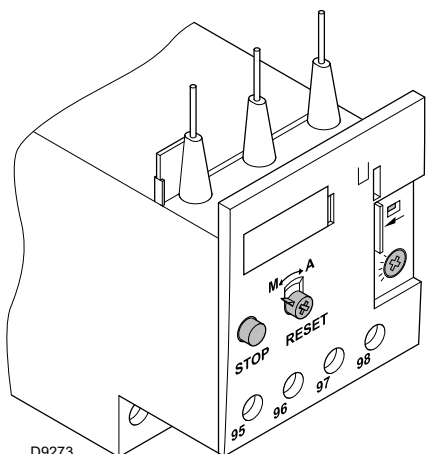

Fig. 35

- To test the overload relay, insert a screwdriver in the window "TEST" (Fig. 36) and move it in the sense of the arrow (towards right).



Automatic resetting can be dangerous.

This action is not provided for the burner operation.

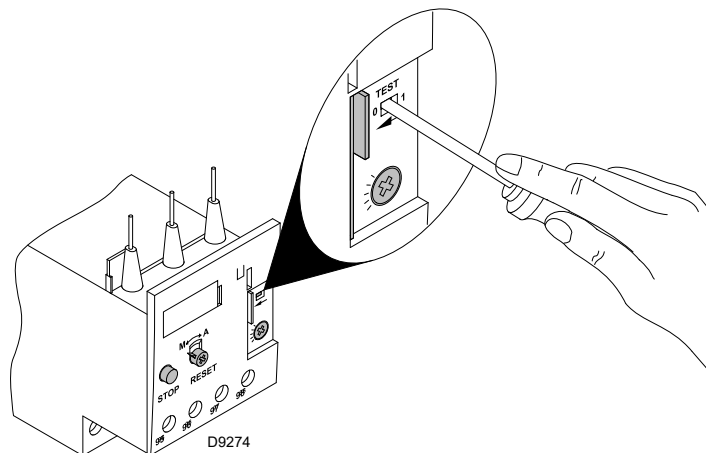

Fig. 36

4.14.2 Electronic relay

- To reset, in the case of an intervention of the electronic relay, press the button "RESET" (Fig. 37).

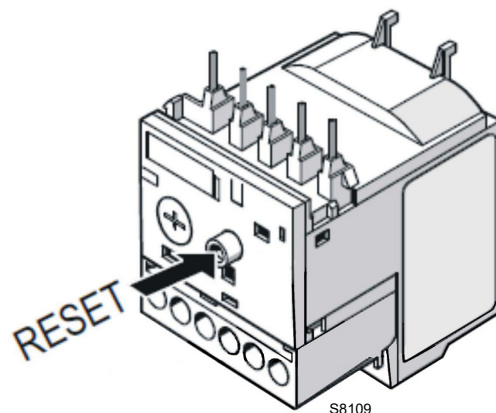

Fig. 37

There are two different solution to test the electronic relay:

- **Device test (Fig. 38)**
Push slowly the button in the window with a little screwdriver.

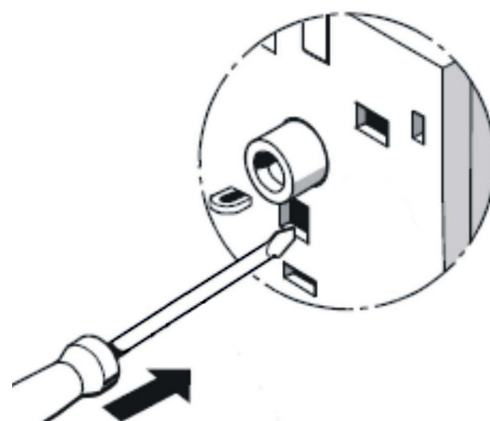

Fig. 38

- **Contact test NC (95-96) and NO (97-98)(Fig. 39)**
Insert in the window a little screwdriver and move it in the sense of the arrow.

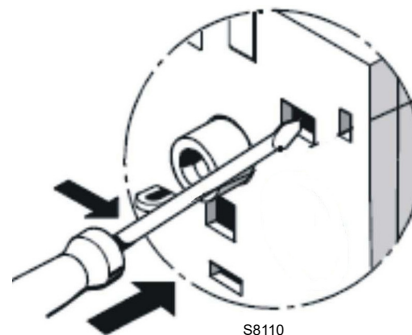
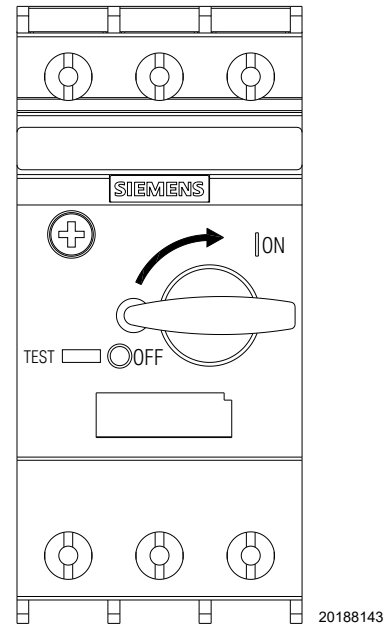

Fig. 39

4.15 Motor protector

To reset, in the case of an intervention of the motor protector, turn into position "ON" the rotatory handle.

**Fig. 40****4.15.1 Device test**

Insert in the window a little screwdriver and move it in the sense of the arrow.

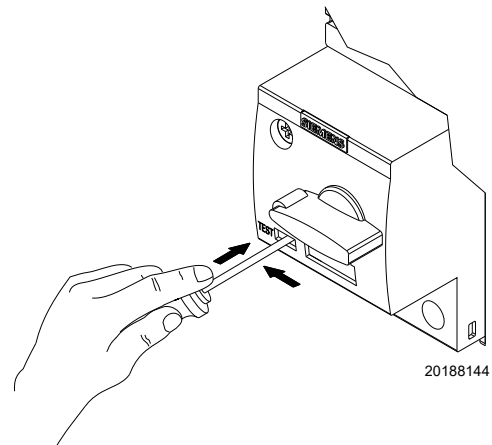
**Fig. 41**

4.16 Motor connection at 208-230 or 460V

WARNING:

the motors, manufactured for 208-230/460 **IE3 NEMA Premium Efficiency** voltage, have the same connection than **IE2/Epact** motors.

IE2/Epact - IE3 NEMA Premium Efficiency

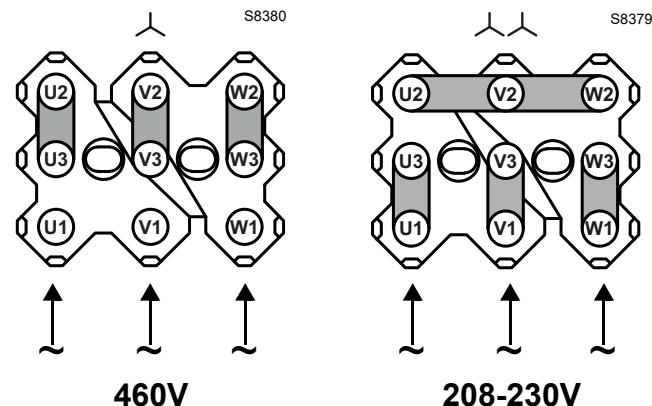

Fig. 42

4.17 Motor connection at 575V

WARNING:

the motors, manufactured for 575V **IE3 NEMA Premium Efficiency** voltage, have the same control box base of the **IE1** and **IE2/Epact** motors. Please pay attention to the indications in case of maintenance or substitution.

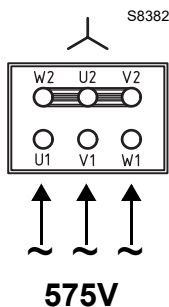

Fig. 43

4.18 Motor rotation

As soon as the burner starts up, go in front of the cooling fan of the fan motor and check it is rotating anticlockwise (Fig. 44).

If this is not the case:

- set the burner switch to "0" (OFF) and wait for the control box to carry out the switch-off phase.



Disconnect the electrical supply from the burner by means of the main system switch.

- Invert the phases on the three-phase motor power supply.

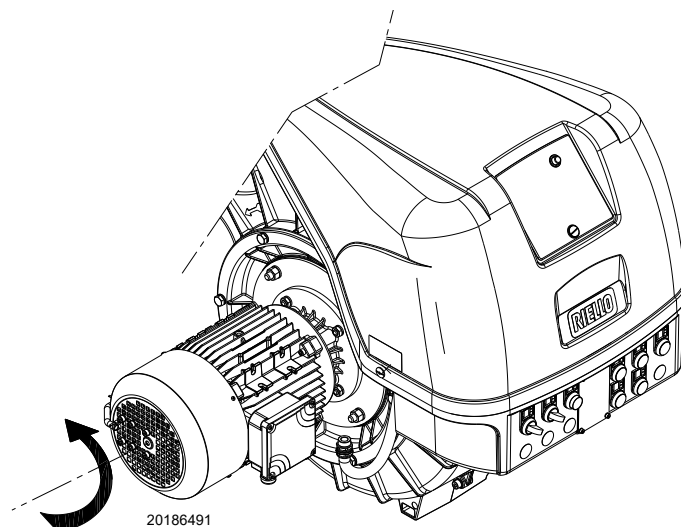

Fig. 44

5

Start-up, calibration and operation of the burner

5.1 Notes on safety for the first start-up



The first start-up of the burner must be carried out by qualified personnel, as indicated in this manual and in compliance with the standards and regulations of the laws in force.



Check the correct working of the adjustment, command and safety devices.



Refer to paragraph "Safety test - with gas ball valve closed" on page 40 before the first start-up.

5.2 Adjustments before first firing (light oil operation)

5.2.1 Combustion head setting

The setting of the combustion head depends exclusively on the maximum delivery of the burner.

5.2.2 Pump adjustment

No settings are required for the pump, which is set to 360 PSI by the manufacturer. This pressure must be checked and adjusted (if required) after the burner has been ignited.

The only operation required in this phase is the application of a pressure gauge on the appropriate pump attachment.

5.2.3 Air damper adjustment

The first time the burner is fired leave the factory setting unchanged for both low and high fire operation.

5.2.4 Electrode position



Make sure that the electrodes are positioned as shown in Fig. 45.

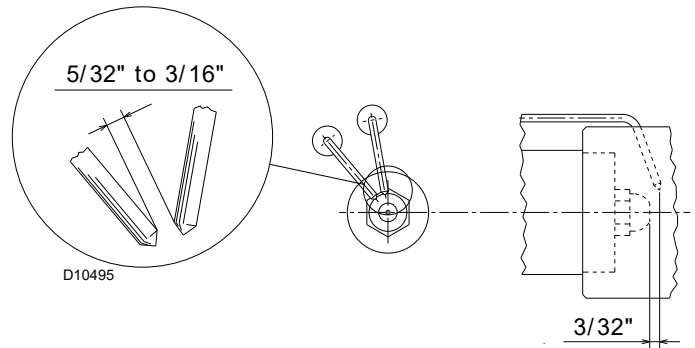

Fig. 45

5.3 Burner firing

- Having completed the checks indicated in the previous heading, the pilot of the burner should fire.
- If the motor starts but the flame does not appear and the flame safeguard goes into lock-out, reset and wait for a new firing attempt.
- Pilot adjustment has been illustrated on Fig. 18, page 21.
- Having adjusted the pilot, reconnect the main valve and ignite the main flame; it might require several attempts to purge the air from the gas lines or to adjust the valve with little gas.
- Once the burner has fired, now proceed with calibration operations.



When fitting the burner on the two slide bars, it is advisable to gently draw out the high tension cables until they are slightly stretched.

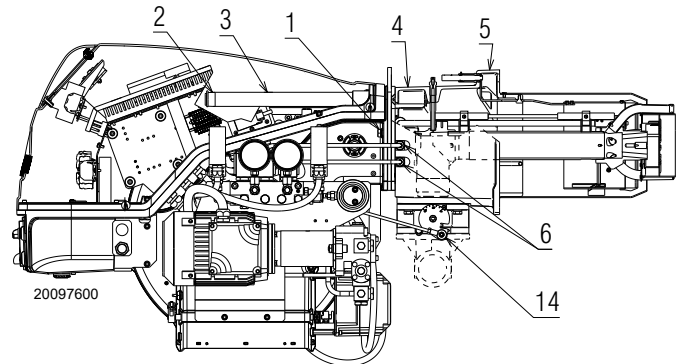

Fig. 46

5.4 Burner calibration

The optimum calibration of the burner requires an analysis of the flue gases at the boiler outlet.

Adjust successively:

- Firing output
- Maximum burner output

- Minimum burner output
- Intermediate outputs between low and high fire
- Air pressure switch
- Minimum gas pressure switch

5.5 Adjustments before first firing (gas operation)

Adjustment of the combustion head has been illustrated on page 21.

In addition, the following adjustments must also be made:

- open manual valves up-stream from the gas train;
- purge the air from the gas line;
- adjust the low gas pressure switch to the start of the scale (Fig. 52, page 37);
- adjust the high gas pressure switch to the upper limit of the scale (Fig. 51, page 36);
- adjust the air pressure switch to the zero position of the scale (Fig. 50, page 36);
- fit a U-type manometer (Fig. 47) to the gas pressure test point on the sleeve.

The manometer readings are used to calculate MAX. burner power using the diagrams on page 27.

Before starting up the burner it is good practice to adjust the gas train so that ignition takes place in conditions of maximum safety, i.e. with gas delivery at the minimum.

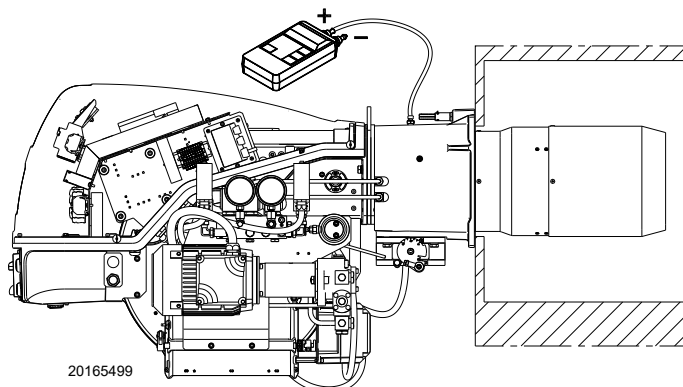

Fig. 47

5.6 Burner start-up

Feed electricity to the burner via the disconnecting switch on the boiler panel.

Close the thermostats/pressure switches, set the parameters on the RWF55 regulator.

Please refer to the specific manual for this operation.

Turn the switch to position "ON" (Fig. 48) and turn the switch of to position "LOCAL" and turn the switch to position "OIL" for oil operation and "GAS" for gas operation.



DANGER

Make sure that the lamps or testers connected to the solenoids, or indicator lights on the solenoids themselves, show that no voltage is present. If voltage is present, stop the burner **immediately** and check the electrical wiring.

5.6.1 Adjusting gas/air delivery

- Move slowly towards the maximum output (butterfly gas valve completely open);
- adjust the required maximum output with the gas pressure stabilizer;
- adjust the combustion parameters with the air servomotor and store the maximum combustion point;
- complete the procedure slowly, synchronizing the combustion with the two servomotors and storing the different setting points.



WARNING

For the start-up procedure and the parameters calibration, refer to the specific instruction manual of the LMV37... electronic cam supplied with the burner.

5.6.2 Adjusting oil/air delivery

- Switch to the light oil operation.
- During the ignition, move slowly with an approximate adjustment to the oil servomotor at maximum 90°.
- Adjust the maximum pressure on the return nozzle through the "nut and lock-nut" 5)(Fig. 16, page 20).
- Adjust the combustion parameter with the air servomotor and store the maximum combustion point.
- Complete the procedure slowly, synchronizing the combustion with the two servomotors.
- Store the different setting points.

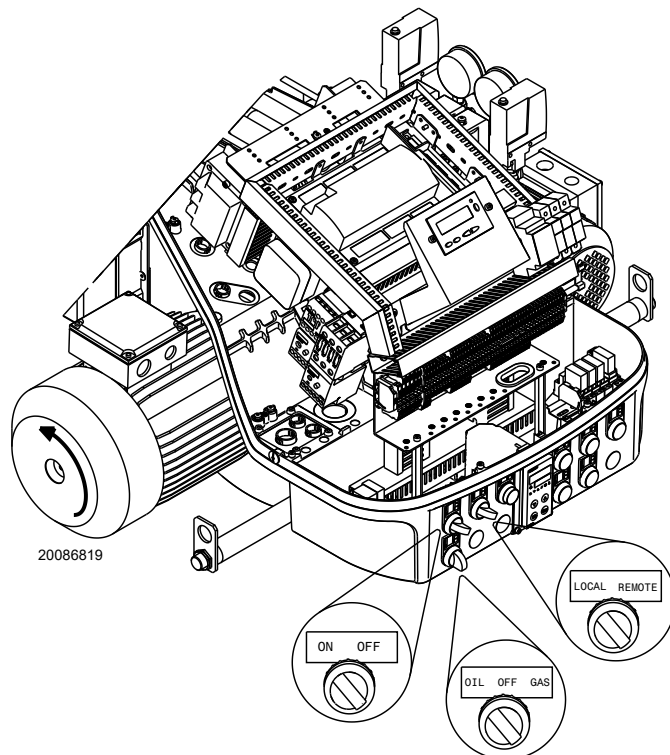

Fig. 48

5.7 Final calibration of the pressure switches

5.7.1 Air pressure switch

The air pressure switch is connected in differential (Fig. 50) and is activated by both the negative pressure of the air intake and the air pressure from the fan.

Adjust the air pressure switch (Fig. 49) after having performed all other burner adjustments with the air pressure switch set to the min. of the scale.

With the burner operating at low fire, adjust the pressure switch by slowly turning the relative knob clockwise until the burner locks out.

Then turn the knob counter-clockwise about 20% of the set point and start-up the burner again to ensure the set point is correct.

If the burner locks out again, turn the knob counter-clockwise a little bit more.

5.7.2 Maximum gas pressure switch

Adjust the maximum gas pressure switch (Fig. 51) after making all other burner adjustments with the maximum gas pressure switch set to the end of the scale.

To calibrate the maximum gas pressure switch, open the tap and then connect a pressure gauge to its pressure test point.

The maximum gas pressure switch must be regulated to a value no higher than 30% of the measurement read on the gauge when the burner is working at maximum output.

After making the adjustment, remove the pressure gauge and close the tap.

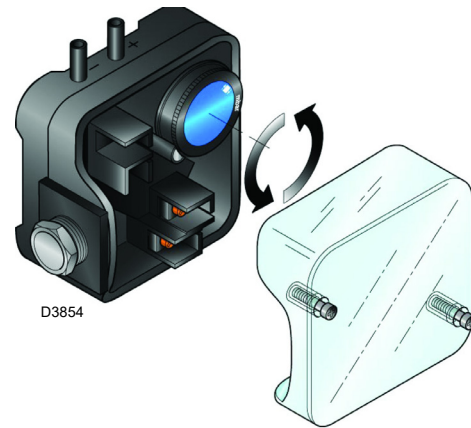

Fig. 49

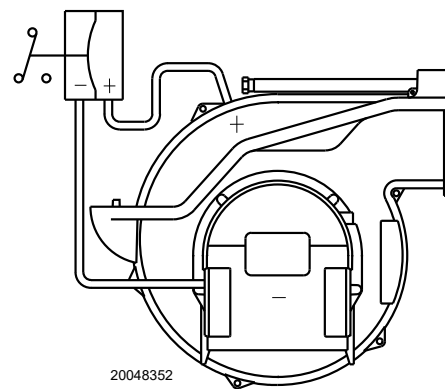

Fig. 50

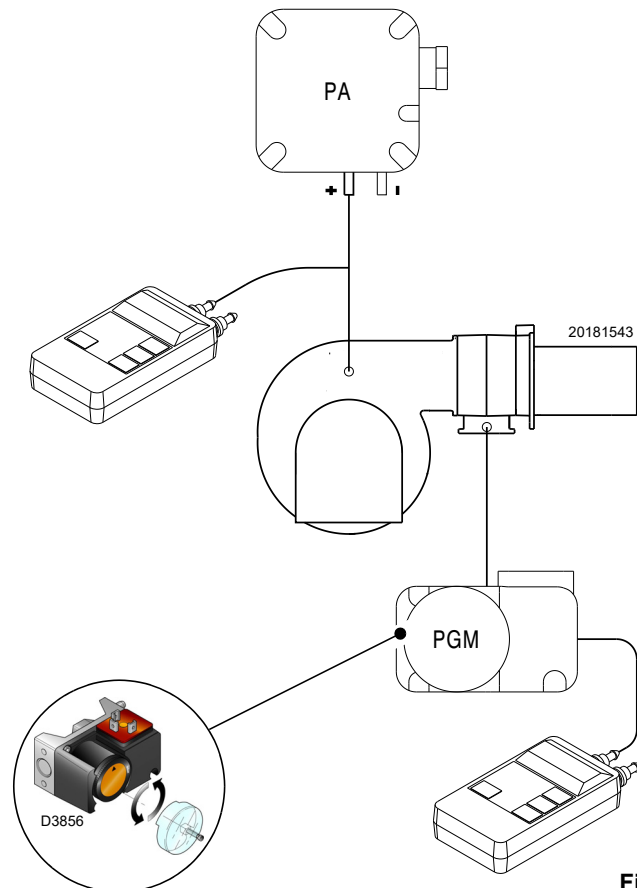

Fig. 51

5.7.3 Minimum gas pressure switch

The purpose of the minimum gas pressure switch is to prevent the burner from operating in an unsuitable way due to too low gas pressure.

Adjust the minimum gas pressure switch (Fig. 52) after having adjusted the burner, the gas valves and the gas train stabiliser. With the burner operating at maximum output:

- install a pressure gauge downstream of the gas train stabiliser (for example at the gas pressure test point on the burner combustion head);
- choke slowly the manual gas cock until the pressure gauge detects a decrease in the pressure read of about 0.1 kPa (1 mbar). In this phase, verify the CO value which must always be less than 100 mg/kWh (93 ppm).
- Increase the adjustment of the gas pressure switch until it intervenes, causing the burner shutdown;
- remove the pressure gauge and close the cock of the gas pressure test point used for the measurement;
- open completely the manual gas cock.



1 kPa = 10 mbar

WARNING

5.7.4 Low oil pressure switch

The low oil pressure switch is factory set to 261 PSI (18 bar).

If the oil pressure goes down this value in the delivery piping, the pressure switch stops the burner.

Burner starts again automatically if the pressure goes above 261 PSI (18 bar) after burner start up.

5.7.5 High oil pressure switch

The high oil pressure switch is factory set to 43.5 PSI (3 bar).

If the oil pressure goes above this value in the return piping, the pressure switch stops the burner.

Burner starts again automatically if the pressure goes down under 43.5 PSI (3 bar) after burner shut down.

If a loop circuit with Px pressure feeds the burner, the pressure switch should be adjusted to Px + 43.5 PSI.

For the adjustment, see Fig. 53.

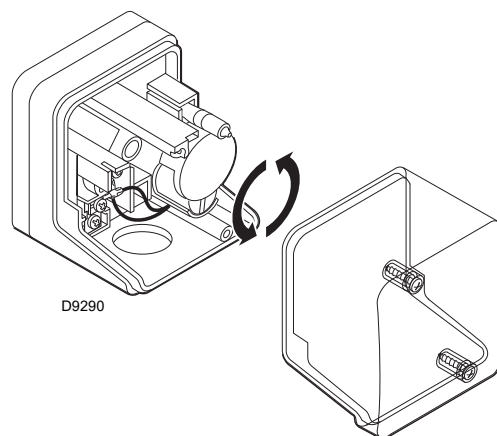

Fig. 52

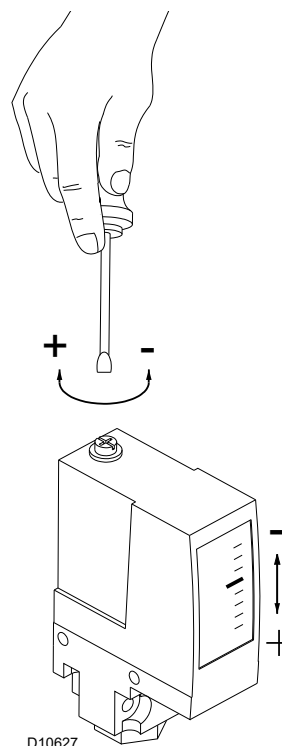

Fig. 53

5.8 Burner starting

- Operating control closes, the motor starts.
The pump 3 (Fig. 54) draws the fuel from the tank through the piping 1) and pumps it under pressure for delivery. The piston 4) rises and the fuel returns to the tank through the piping 5) - 7).
The screw 6) closes the by-pass heading towards suction and the de-energized solenoid valves 8) - 9) - 2) close the passage to the nozzle.
- Air damper and pressure regulator are positioned on MIN output.
- Ignition electrode strikes a spark.
- Solenoid valves 8) - 9) - 2) open; the fuel passes through the piping 10) and filter 11), and enters the nozzle.
A part of the fuel is then sprayed out through the nozzle, igniting when it comes into contact with the spark: flame at a low output level; the rest of the fuel passes through piping 12) at the pressure adjusted by the regulator 13), then, through piping 7), it goes back into the tank.
- The spark goes out.
- The starting cycle ends.

5.8.1 Steady state operation

At the end of the starting cycle, the servo-motor control then passes to load control for boiler pressure or temperature.

- If the temperature or pressure is low (and the load control is consequently closed), the burner progressively increases output up to MAX.
- If subsequently the temperature or pressure increases until the load control opens, the burner progressively decreases output down to MIN.
- The burner shuts off when demand for heat is less than the heat supplied by the burner in the MIN output.
- The servomotor returns to the 0° angle limited by contact with cam 2. The air damper closes completely to reduce thermal dispersion to a minimum.

Every time output is changed, the servomotor automatically modifies oil delivery (pressure regulator) and air delivery (fan damper).

5.9 Flame signal measurement

Check the flame signal through the parameter 954, as indicated in Fig. 55. The displayed value is expressed in percentage.

The value during the operation must be higher than 24%. If at the burner start-up the value is higher or equal of 18%, the burner locks out due to the extraneous light.

For further and specific information, please refer to the specific instruction manual.

The display (Fig. 55) shows parameter **954**: flashing on the left. On the right, the flame's intensity is displayed as a percentage.
Example: **954: 0.0**

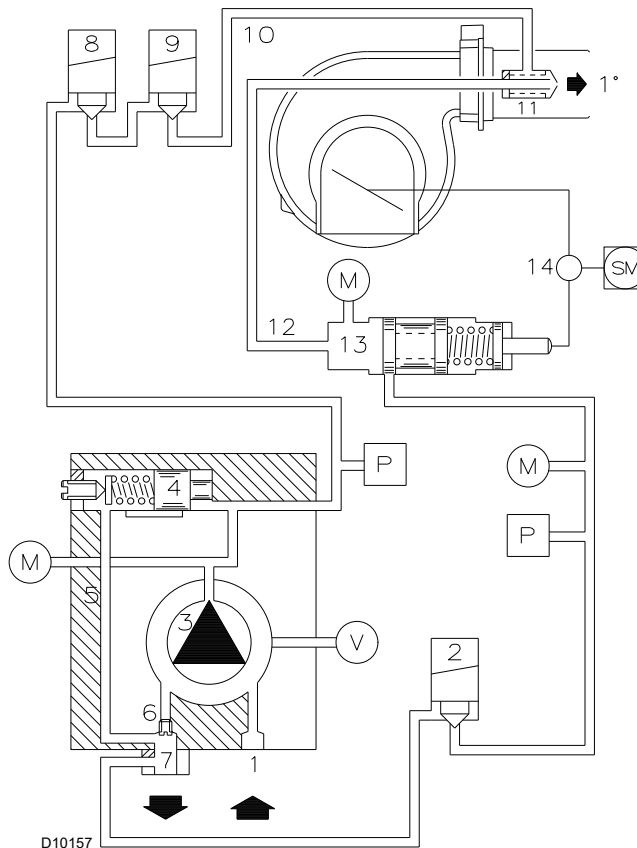

Fig. 54

5.8.2 Firing failure

- If the burner does not fire, it goes into lock-out within 3 sec. of the opening of the light oil valve.
- If the flame should go out for accidental reasons during operation, the burner will lock out in 1 s.

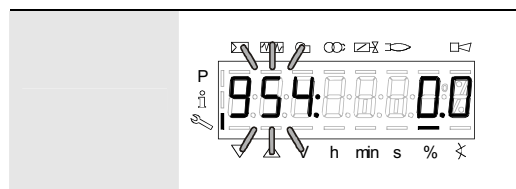





Fig. 55

5.10 Final checks (with the burner working)

<ul style="list-style-type: none"> ➤ Open the control limit operation ➤ Open the high limit operation 		<p>The burner must stop</p>
<ul style="list-style-type: none"> ➤ Rotate the maximum gas pressure switch knob to the minimum end-of-scale position ➤ Rotate the air pressure switch knob to the maximum end of scale position ➤ Rotate the maximum oil pressure switch at the minimum of the scale 		<p>The burner must stop in lockout</p>
<ul style="list-style-type: none"> ➤ Switch off the burner and disconnect the voltage ➤ Disconnect the minimum gas pressure switch ➤ Rotate the minimum low oil pressure switch at the maximum of the scale 		<p>The burner must not start</p>
<ul style="list-style-type: none"> ➤ Cover the flame sensor 		<p>The burner must stop in lockout due to firing failure</p>



Make sure that the mechanical locking systems on the different adjustment devices are fully tightened.

6

Maintenance

6.1 Notes on safety for the maintenance

The periodic maintenance is essential for the good operation, safety, yield and duration of the burner.

It allows you to reduce consumption and polluting emissions and to keep the product in a reliable state over time.



The maintenance interventions and the calibration of the burner must only be carried out by qualified, authorised personnel, in accordance with the contents of this manual and in compliance with the standards and regulations of current laws.

Before carrying out any maintenance, cleaning or checking operations:



Disconnect the electrical supply from the burner by means of the main system switch.



Close the fuel interception tap.



Wait for the components in contact with heat sources to cool down completely.

6.2 Maintenance programme

6.2.1 Maintenance frequency



The gas combustion system should be checked at least once a year by a representative of the manufacturer or another specialised technician.

6.2.2 Safety test - with gas ball valve closed

It is fundamental to ensure the correct execution of the electrical connections between the gas solenoid valves and the burner to perform safely the commissioning.

For this purpose, after checking that the connections have been carried out in accordance with the burner's electrical diagrams, an ignition cycle with closed gas ball valve -dry test- must be performed.

- 1 The manual ball gas valve must be closed
- 2 The electrical contacts of the burner limit switch need to be closed
- 3 Ensures closed the contact of the low gas pressure switch
- 4 Make a trial for burner ignition

The start-up cycle must be as follows:

- Starting the fan for pre-ventilation
- Performing the gas valve seal control, if provided
- Completion of pre-ventilation
- Arrival of the ignition point
- Power supply of the ignition transformer
- Electrical Supply of solenoid gas valves

Since the manual gas ball valve is closed, the burner will not light up and its control box will go to a safety lockout condition.

The actual electrical supply of the solenoid gas valves can be verified by inserting a tester. Some valves are equipped with light signals (or close/open position indicator) that turn on at the same time as their power supply.



IF THE ELECTRICAL SUPPLY OF THE GAS VALVES OCCURS AT UNEXPECTED TIMES, DO NOT OPEN MANUAL GAS BALL VALVE, SWITCH OFF POWER LINE; CHECK THE WIRES; CORRECT THE ERRORS AND REPEAT THE COMPLETE TEST.

6.2.3 Checking and cleaning



The operator must use the required equipment during maintenance.

Combustion

The optimum calibration of the burner requires an analysis of the flue gases. Significant differences with respect to the previous measurements indicate the points where more care should be exercised during maintenance.

Combustion head

Open the burner and make sure that all components of the combustion head are in good condition, not deformed by the high temperatures, free of impurities from the surroundings and correctly positioned. If in doubt, disassemble the elbow fitting 7)(Fig. 58, page 42).

Fuel tank

Approximately every 5 years, or whenever necessary, suck any water or other impurities present on the bottom of the tank using a separate pump.

Flame inspection window

Clean the flame inspection window 1)(Fig. 56).

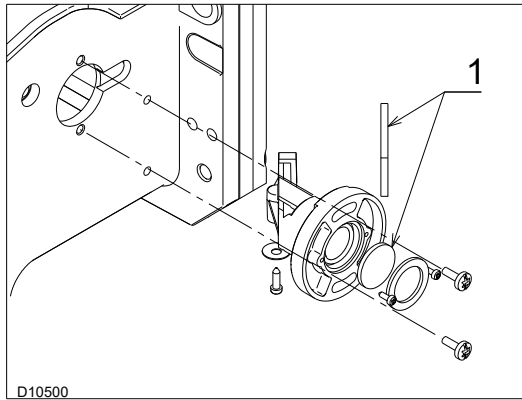

Fig. 56

Filters

Check the filtering baskets on line and at nozzle present in the system. Clean or replace if necessary.

If rust or other impurities are observed inside the pump, use a separate pump to lift any water and other impurities that may have deposited on the bottom of the tank.

Nozzles

It is advisable to replace nozzles every year during regular maintenance operations.

Do not clean the nozzle openings; do not even open them.

Flexible hoses

Check to make sure that the flexible hoses are still in good condition and that they are not crushed or otherwise deformed.

Gas leaks

Make sure that there are no gas leaks on the pipework between the gas meter and the burner.

Gas filter

Change the gas filter when it is dirty.

Flame sensor

In order to reach the flame sensor, proceed as follows:

- extract the sensor 2)(Fig. 57);
- clean the glass cover from any dust that may have accumulated.

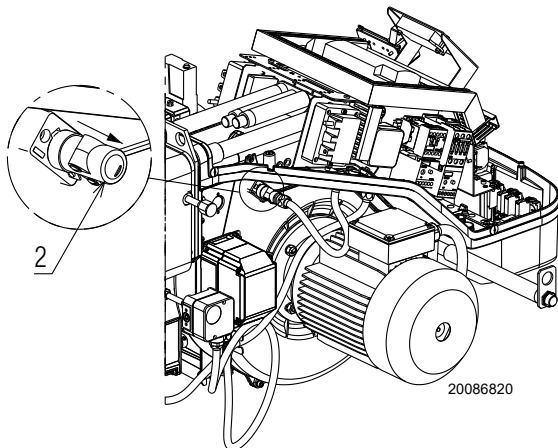

Fig. 57

Burner

Check for excess wear or loose screws. Also make sure that the screws securing the electrical leads in the burner connections are fully tightened.

Clean the outside of the burner.

Combustion

Adjust the burner if the combustion values found at the beginning of the operation do not comply with the regulations in force, or at any rate, do not correspond to good combustion.

6.2.4 Safety components

The safety components must be replaced at the end of their life cycle indicated in Tab. M. The specified life cycles do not refer to the warranty terms indicated in the delivery or payment conditions.

Safety component	Life cycle
Flame control	10 years or 250,000 operation cycles
Flame sensor	10 years or 250,000 operation cycles
Gas valves (solenoid)	10 years or 250,000 operation cycles
Pressure switches	10 years or 250,000 operation cycles
Pressure adjuster	15 years
Servomotor (electronic cam) (if present)	10 years or 250,000 operation cycles
Oil valve (solenoid) (if present)	10 years or 250,000 operation cycles
Oil regulator (if present)	10 years or 250,000 operation cycles
Oil pipes/ couplings (metallic) (if present)	10 years
Flexible hoses (if present)	5 years or 30,000 pressurised cycles
Fan impeller	10 years or 500,000 start-ups

Tab. M

6.3 Opening the burner



Disconnect the electrical supply from the burner by means of the main system switch.



Close the fuel interception tap.



Wait for the components in contact with heat sources to cool down completely.

To open the burner proceed as follows:

- loosen screws 1)(Fig. 58) and withdraw the cover 2);
- disengage the swivel coupling 7) from the graduated sector;
- disconnect the light-oil pipes 8);
- remove screws 3) and pull the burner back by about 4" on the slide bars. disconnect the electrode leads;
- install the extension bars 31)(Fig. 6, page 11) and re-screw the 2 screws and the safety plate (Fig. 12, page 18);
- pull the burner fully back;
- now extract the internal part 5) after having removed the screw 6).

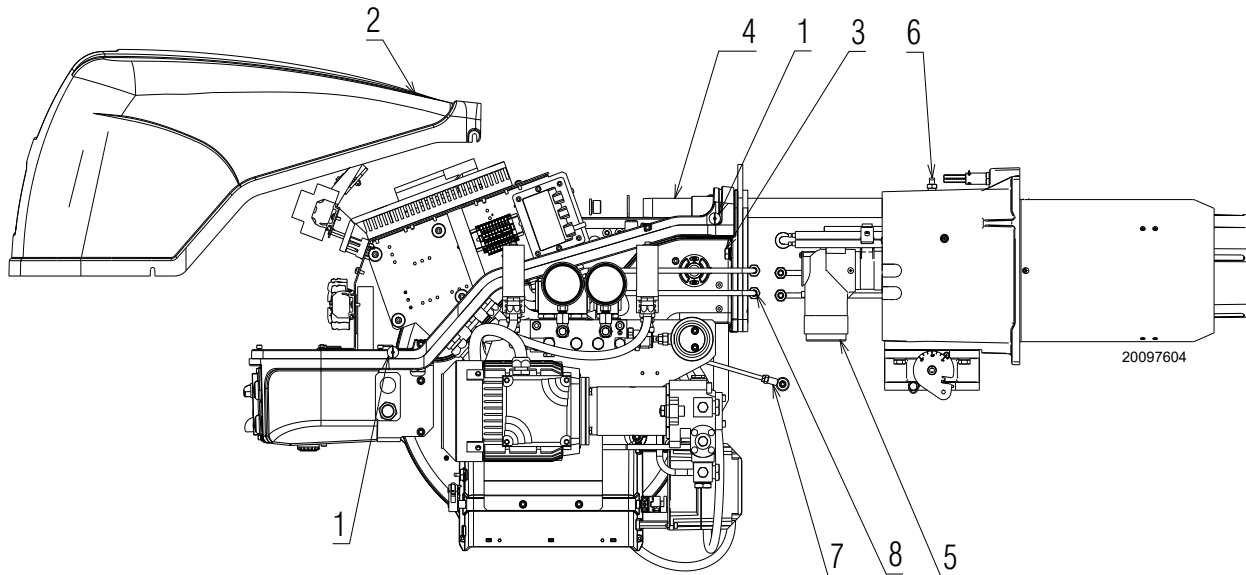

Fig. 58

6.4 Closing the burner

To close the burner proceed as follows:

- push the burner until it is about 4" from the sleeve;
- re-connect the leads;
- remove the extension bars 31)(Fig. 6, page 11);
- slide in the burner until it comes to a stop;
- refit screws 3) and pull the leads gently out until they are slightly stretched;
- re-couple the swivel coupling 7) to the graduated sector;
- reconnect the light-oil pipes;
- re-screw the 2 screws and the safety plate (Fig. 12, page 18).



After carrying out maintenance, cleaning or checking operations, reassemble the hood and all the safety and protection devices of the burner.

A

Appendix - Spare parts

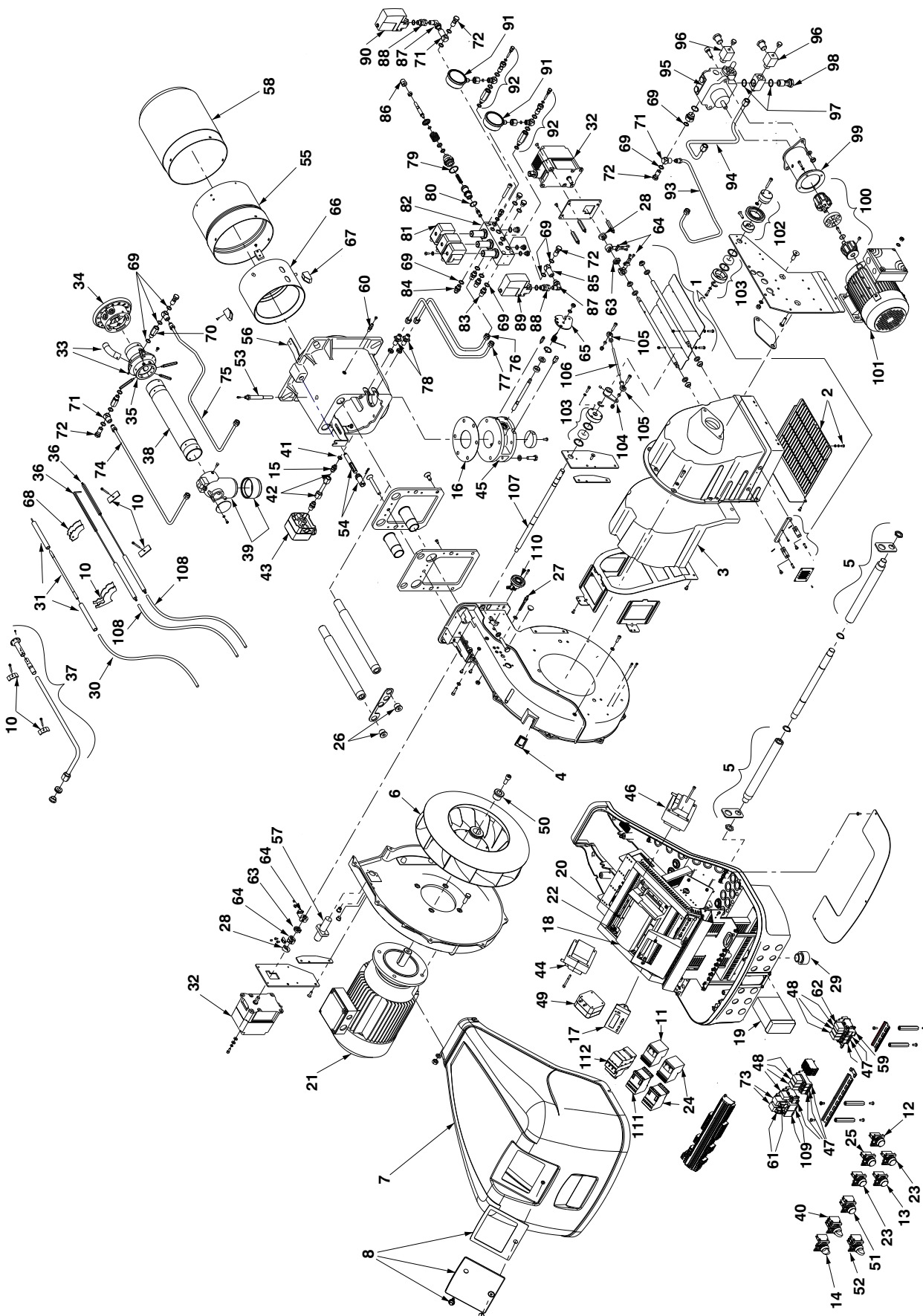

N.	CODE			DESCRIPTION	*
		20163121 - (20171536 / 20171675)	20163126 - (20171537)		
1	20073258	•	•	AIR DAMPER ASSEMBLY	
2	3013683	•	•	PROTECTION GRATE	
3	3013682	•	•	SOUND DAMPING	
4	3003763	•	•	INSPECTION WINDOW	
5	3013686	•	•	BAR EXTENSION	
6	3012976	•	•	FAN	
7	20086561	•	•	COVER	
8	20075921	•	•	VIEWING PORT	
10	20028328	•	•	SUPPORT	
11	20150682		•	STARTER	B
12	20027018	•	•	RED SIGNAL LIGH	
13	20027020	•	•	YELLOW SIGNAL LIGHT	
14	20027021	•	•	SELECTOR SWITCH	
15	3013095	•	•	CONNECTOR	C
16	3005482	•	•	SEAL	C
17	3013926	•	•	DISPLAY	B
18	20028329	•	•	ELECTRONIC CAM	
19	20096592	•	•	POWER REGULATOR	C
20	3013940	•	•	CONNECTORS ASSEMBLY	
21	3014152	•		MOTOR	C
21	20118879		•	MOTOR	C
22	3014106	•	•	FUSE	C
23	20036017	•	•	GREEN SIGNAL LIGHT	A
24	20115421	•		STARTER	B
24	20115409		•	STARTER	B
25	20027014	•	•	WHITE SIGNAL LIGHT	
26	3013681	•	•	SCREW	
27	3003891	•	•	CONNECTOR	
28	3014079	•	•	SPACER	C
29	20031413	•	•	HORN	
30	20157896	•	•	HIGH VOLTAGE LEAD	C
31	20028332	•	•	ELECTRODE	
32	20008601	•	•	SERVOMOTOR	A
33	3013422	•	•	TUBE	
34	20031016	•	•	DIFFUSER DISC	A
35	20028947	•	•	DISTRIBUTOR	
36	20028336	•	•	ELECTRODE	
37	20028337	•	•	IGNITION PILOT TUBE	
38	20031019	•	•	GAS PIPE	

N.	CODE			DESCRIPTION	*
		20163121 - (20171536 / 20171675)	20163126 - (20171537)		
39	20031020	•	•	ELBOW	A
40	20027422	•	•	SELECTOR SWITCH	
41	3007891	•	•	SEAL	C
42	3013055	•	•	TUBE	B
43	3012969	•	•	GAS PRESSURE SWITCH	A
44	3012956	•	•	TRANSFORMER	B
45	3006096	•	•	GAS REGULATOR	B
46	3012938	•	•	TRANSFORMER	C
47	3012841	•	•	BASE	B
48	20010969	•	•	RELAY	B
49	3012948	•	•	AIR PRESSURE SWITCH	B
50	3003643	•	•	PLUG	A
51	20010962	•	•	BUTTON	
52	20028411	•	•	SELECTOR SWITCH	
53	3012049	•	•	SCREW	C
54	3012639	•	•	ADJUSTMENT ASSEMBLY	
55	3012560	•	•	SHUTTER	
56	3013419	•	•	BRACKET	
57	20186817	•	•	FLAME SENSOR	
58	3012561	•	•	END CONE	A
59	3020071	•	•	BASE	
60	3003322	•	•	CONNECTOR	
61	20043329	•	•	TIMER	
62	3020068	•	•	RELAY	B
63	3013938	•	•	DISC	B
64	3013937	•	•	HUB	
65	20028379	•	•	GRADUATE SECTOR	C
66	3013421	•	•	CYLINDER	C
67	3012647	•	•	CENTERING SUPPORT	
68	20031021	•	•	SUPPORT	
69	3007079	•	•	SEAL	
70	3013417	•	•	CONNECTOR	B
71	3006784	•	•	CONNECTOR	C
72	3003006	•	•	CONNECTOR	C
73	20030708	•	•	RELAY	B
74	20031017	•	•	TUBE	B
75	20031018	•	•	TUBE	A
76	20028383	•	•	TUBE	A
77	20028384	•	•	TUBE	A
78	20028385	•	•	CONNECTOR	A

N.	CODE			DESCRIPTION	*
		20163121 - (20171536 / 20171675)	20163126 - (20171537)		
79	3003204	•	•	SEAL	C
80	3007150	•	•	O-RING	B
81	3003287	•	•	COIL	B
82	20028386	•	•	MODULATOR	
83	3006723	•	•	CONNECTOR	
84	3009081	•	•	CONNECTOR	C
85	3012126	•	•	CONNECTOR	C
86	3003200	•	•	NUT	C
87	3014179	•	•	CONNECTOR	
88	3013462	•	•	CONNECTOR	C
89	3013674	•	•	PRESSURE SWITCH	C
90	3012384	•	•	PRESSURE SWITCH	B
91	3006140	•	•	PRESSURE GAUGE	B
92	3013531	•	•	NEEDLE VALVE	A
93	20028389	•	•	TUBE	
94	20028390	•	•	TUBE	A
95	3006157	•	•	PUMP	A
96	3012949	•	•	CONNECTOR	C
97	3007164	•	•	SEAL	C
98	3006184	•	•	BAR	B
99	20027570	•	•	JOINT	
100	20028394	•	•	DRIVE COUPLING	
101	20031015	•		MOTOR	A
101	20062588		•	MOTOR	C
102	3013259	•	•	BEARING	C
103	3013257	•	•	ANCHOR PLATE	C
104	20028396	•	•	LEVER	
105	3006098	•	•	PIN JOINT	
106	3013897	•	•	TIE ROD	
107	20028398	•	•	SHAFT	
108	3012959	•	•	HIGH VOLTAGE LEAD	A
109	20028400	•	•	BASE	
110	3013933	•	•	INSPECTION WINDOW	
111	20118869	•	•	CONTACTOR	
112	20186835	•		MOTOR PROTECTOR	C

*

ADVISED PARTS

A = Spare parts for minimum fittings

A+B = Spare parts for basic safety fittings

A+B+C = Spare parts for extended safety fittings

B**Appendix - Accessories**

- **Kit for lengthening the combustion head**

Burner	Standard length	Length obtainable with kit	Code
RLS 190/E	16 ⁷ / ₃₂ "	21 ¹¹ / ₃₂ "	20030482

- **Head kit for "reverse flame chamber"**

Burner	Code
RLS 190/E	3010241

- **Gas train according to UL Standards**

**WARNING**

The installer is responsible for the supply and installation of any required safety device(s) not indicated in this manual.

C**Appendix - Burner start up report**

Model number:	_____	Serial number:	_____
Project name:	_____	Start-up date:	_____
Installing contractor:	_____	Phone number:	_____

GAS OPERATION

Gas Supply Pressure:	_____	CO ₂ : Low Fire	_____	High Fire	_____
Main Power Supply:	_____	O ₂ : Low Fire	_____	High Fire	_____
Control Power Supply:	_____	CO: Low Fire	_____	High Fire	_____
Burner Firing Rate:	_____	NO _x : Low Fire	_____	High Fire	_____
Manifold Pressure:	_____	Net Stack Temp - Low Fire:	_____	High Fire	_____
Pilot Flame Signal:	_____	Comb. Efficiency - Low Fire:	_____	High Fire	_____
Low Fire Flame Signal:	_____	Overfire Draft:	_____		
High Fire Flame Signal:	_____				

OIL OPERATION

Oil supply pressure:	_____	CO ₂ : Low Fire	_____	High Fire	_____
Oil suction pressure:	_____	O ₂ : Low Fire	_____	High Fire	_____
Control Power Supply:	_____	CO: Low Fire	_____	High Fire	_____
Burner Firing Rate:	_____	NO _x : Low Fire	_____	High Fire	_____
Low Fire Flame Signal:	_____	Net Stack Temp - Low Fire:	_____	High Fire	_____
High Fire Flame Signal:	_____	Comb. Efficiency - Low Fire:	_____	High Fire	_____
Low Fire Nozzle Size:	_____	Overfire Draft:	_____		
High Fire Nozzle Size:	_____	Smoke number:	_____		

CONTROL SETTINGS

Operating Setpoint:	_____	Low Oil Pressure:	_____
High Limit Setpoint:	_____	High Oil Pressure:	_____
Low Gas Pressure:	_____	Flame Safeguard Model Number:	_____
High Gas Pressure:	_____	Modulating Signal Type:	_____

NOTES

RIELLO

RIELLO S.p.A.
I-37045 Legnago (VR)
Tel.: +39.0442.630111
[http:// www.riello.com](http://www.riello.com)

RIELLO

35 Pond Park Road
Hingham, Massachusetts,
U.S.A. 02043

RIELLO BURNERS NORTH AMERICA
<http://www.riello.ca>

1-800-4-RIELLO

2165 Meadowpine Blvd
Mississauga, Ontario
Canada L5N 6H6