

GB Forced draught gas burners

Progressive two-stage or modulating operation

CODE	MODEL
20189628 - 20189629 - 20189631 - 20189627 20189632 - 20189633 - 20189634	RS 68/E LN RS 68/EV LN
20189726 - 20189794 - 20189795 20189732 - 20189735 - 20189737	RS 120/E LN RS 120/EV LN



Original instructions

1	Information and general instructions	3
1.1	Information about the instruction manual	3
1.1.1	Introduction	3
1.1.2	General dangers	3
1.1.3	Other symbols	3
1.2	Guarantee and responsibility	4
1.2.1	Owner's responsibility	4
2	Safety and prevention	5
2.1	Introduction	5
2.2	Personnel training	5
3	Technical description of the burner	6
3.1	Technical data	6
3.2	Electrical data	6
3.3	Burner models designation	7
3.4	Burner equipment	7
3.5	Burner dimensions	8
3.6	Firing rates	8
3.6.1	Procedure to refer burner operating condition at an altitude and/or at a combustion supporter air temperature different to the standard values (328 ft above sea level, 68 °F)	9
3.7	Minimum furnace dimensions	10
3.8	Commercial boilers	10
3.9	Burner description	11
3.10	Flame control (LMV37.4...)	12
3.11	Actuators (SQM33.5...)	15
4	Installation	16
4.1	Notes on safety for the installation	16
4.2	Handling	16
4.3	Preliminary checks	16
4.4	Operation position	16
4.5	Preparing the boiler	17
4.5.1	Boiler plate	17
4.6	Securing the burner to the boiler	17
4.7	Electrode positioning	18
4.8	Combustion head calibration	18
4.9	Adjustment of the combustion head	19
4.9.1	Air adjustment	19
4.9.2	Gas adjustment	19
4.10	Burner refitting	20
4.11	Gas supply	21
4.11.1	Gas train	21
4.11.2	Gas feeding line	21
4.11.3	Gas valve electrical connections	22
4.12	Gas supply pressure	24
4.13	Electrical wiring	25
4.14	Overload relay calibration	26
4.14.1	Electro-mechanical overload relay	26
4.14.2	Electronic relay	26
4.15	Motor connection at 208-230 or 460V	27
4.16	Motor connection at 575V	27
4.17	Motor rotation	27

5	Start-up, calibration and operation of the burner	28
5.1	Notes on safety for the first start-up	28
5.2	Operations before start-up	28
5.3	Burner start-up	28
5.4	Adjusting gas/air delivery	29
5.5	Final calibration of the pressure switches	29
5.5.1	Air pressure switch	29
5.5.2	Maximum gas pressure switch	29
5.5.3	Minimum gas pressure switch	30
5.6	Flame signal measurement	30
5.7	Final checks (with the burner working)	30
6	Maintenance	31
6.1	Notes on safety for the maintenance	31
6.2	Maintenance programme	31
6.2.1	Maintenance frequency	31
6.2.2	Safety test - with gas ball valve closed	31
6.2.3	Checking and cleaning	31
6.2.4	Safety components	32
6.3	Opening the burner	33
6.4	Closing the burner	33
A	Appendix - Spare parts	34
B	Appendix - Accessories	39
C	Appendix - Burner start up report	40

1 Information and general instructions

1.1 Information about the instruction manual

1.1.1 Introduction

The instruction manual supplied with the burner:

- is an integral and essential part of the product and must not be separated from it; it must therefore be kept carefully for any necessary consultation and must accompany the burner even if it is transferred to another owner or user, or to another system. If the manual is lost or damaged, another copy must be requested from the Technical Assistance Service of the area;
- is designed for use by qualified personnel;
- offers important indications and instructions relating to the installation safety, start-up, use and maintenance of the burner.

Symbols used in the manual

In some parts of the manual you will see triangular DANGER signs. Pay great attention to these, as they indicate a situation of potential danger.

1.1.2 General dangers

The **dangers** can be of **3 levels**, as indicated below.



DANGER

Maximum danger level!

This symbol indicates operations which, if not carried out correctly, cause serious injury, death or long-term health risks.



WARNING

This symbol indicates operations which, if not carried out correctly, may cause serious injury, death or long-term health risks.



CAUTION

This symbol indicates operations which, if not carried out correctly, may cause damage to the machine and/or injury to people.

1.1.3 Other symbols



DANGER

DANGER: LIVE COMPONENTS

This symbol indicates operations which, if not carried out correctly, lead to electric shocks with lethal consequences.



DANGER: FLAMMABLE MATERIAL

This symbol indicates the presence of flammable materials.



DANGER: BURNING

This symbol indicates the risks of burns due to high temperatures.



DANGER: CRUSHING OF LIMBS

This symbol indicates the presence of moving parts: danger of crushing of limbs.



WARNING: MOVING PARTS

This symbol indicates that you must keep limbs away from moving mechanical parts; danger of crushing.



DANGER: EXPLOSION

This symbol signals places where an explosive atmosphere is present. An explosive atmosphere is defined as a mixture of dangerous substances with air, under atmospheric conditions, in the form of gases, vapours, mist or dust in which, after ignition has occurred, combustion spreads to the entire unburned mixture.



PERSONAL PROTECTION EQUIPMENT

These symbols indicate the equipment that must be worn and kept by the operator for protection against threats against safety and/or health while at work.



MOUNT CASING

This symbol indicates that it is mandatory to mount casing again after maintenance, cleaning or checks.



ENVIRONMENTAL PROTECTION

This symbol gives indications for the use of the machine with respect for the environment.



IMPORTANT INFORMATION

This symbol indicates important information that you must bear in mind.



This symbol indicates a list.

Abbreviations used

Ch.	Chapter
Fig.	Figure
Page	Page
Sec.	Section
Tab.	Table

Delivery of the system and the instruction manual

When the system is delivered, it is important that:

- The instruction manual is supplied to the user by the system manufacturer, with the recommendation to keep it in the room where the heat generator is to be installed.
- The instruction manual shows:
 - the serial number of the burner;



- the address and telephone number of the nearest Assistance Centre;

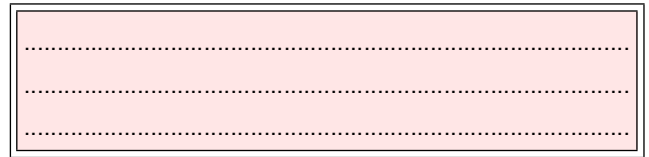

- The system supplier carefully informs the user about:
 - the use of the system,
 - any further tests that may be necessary before the system is started up,
 - maintenance and the need to have the system checked at least once a year by the manufacturer or another specialised technician.
 To ensure a periodic check, the manufacturer recommends the drawing up of a Maintenance Contract.

1.2 Guarantee and responsibility

The manufacturer guarantees its new products from the installation date, in accordance with the regulations in force and/or the sales contract. At the moment of the first start-up, check that the burner is integral and complete.



WARNING

Failure to observe the information given in this manual, operating negligence, incorrect installation and the carrying out of non authorised modifications will result in the annulment by the manufacturer of the guarantee that it supplies with the burner.

In particular, the rights to the guarantee and the responsibility will no longer be valid, in the event of damage to things or injury to people, if such damage/injury was due to any of the following causes:

- incorrect installation, start-up, use and maintenance of the burner;
- improper, incorrect or unreasonable use of the burner;
- intervention of unqualified personnel;
- carrying out of non authorised modifications on the equipment;
- use of the burner with safety devices that are faulty, incorrectly applied and/or not working;
- installation of untested supplementary components on the burner;
- powering of the burner with unsuitable fuels;
- faults in the fuel power supply system;
- use of the burner even following an error and/or an irregularity;
- repairs and/or overhauls incorrectly carried out;
- modification of the combustion chamber with inserts that prevent the regular development of the flame, as structurally established;
- insufficient and inappropriate surveillance and care of those burner components most subject to wear and tear;
- use of non-original components, including spare parts, kits, accessories and optionals;
- force majeure.

the manufacturer furthermore declines any and every responsibility for the failure to observe the contents of this manual.

1.2.1 Owner's responsibility

Please pay attention to the Safety Warnings contained within this instruction manual. Keep this manual for your records and provide it to your qualified service agency for use in professionally setting up and maintaining your burner.

Your burner will provide years of efficient operation if it is professionally installed and maintained by a qualified service technician. If at any time the burner does not appear to be operating properly, immediately contact your qualified service agency for consultation.

We recommend annual inspection/service of your gas heating system by a qualified service agency.

Failure to follow these instructions, misuse, or incorrect adjustment of the burner could lead to equipment malfunction and result in asphyxiation, explosion or fire.



WARNING

If you smell gas:

- Do not touch any electrical items.
- Open all windows.
- Close all gas supply valves.
- Contact your local gas authority immediately.
- Do not store flammable or hazardous materials in the vicinity of fuel burning appliances.
- Improper installation, adjustment, alteration, service or maintenance can cause property damage, personal injury or death.
- Refer to this manual for instructional or additional information.
- Consult a certified installer, service representative or the gas supplier for further assistance.
- Burner shall be installed in accordance with manufacturers requirements as outlined in this manual, local codes and authorities having jurisdiction.

2 Safety and prevention

2.1 Introduction

The burners have been designed and built in compliance with current regulations and directives, applying the known technical rules of safety and envisaging all the potential danger situations.

It is necessary, however, to bear in mind that the imprudent and clumsy use of the equipment may lead to situations of death risk for the user or third parties, as well as the damaging of the burner or other items. Inattention, thoughtlessness and excessive confidence often cause accidents; the same applies to tiredness and sleepiness.

It is a good idea to remember the following:

- The burner must only be used as expressly described. Any other use should be considered improper and therefore dangerous.

In particular:

it can be applied to boilers operating with water, steam, diathermic oil, and to other users expressly named by the manufacturer; the type and pressure of the fuel, the voltage and frequency of the electrical power supply, the minimum and maximum deliveries for which the burner has been regulated, the pressurisation of the combustion chamber, the dimensions of the combustion chamber and the room temperature must all be within the values indicated in the instruction manual.

- Modification of the burner to alter its performance and destinations is not allowed.
- The burner must be used in exemplary technical safety conditions. Any disturbances that could compromise safety must be quickly eliminated.
- Opening or tampering with the burner components is not allowed, apart from the parts requiring maintenance.
- Only those parts envisaged by the manufacturer can be replaced.



The manufacturer guarantees safety and proper functioning only if all burner components are intact and positioned correctly.

2.2 Personnel training

The user is the person, body or company that has acquired the machine and intends to use it for the specific purpose. He is responsible for the machine and for the training of the people working around it.

The user:

- undertakes to entrust the machine exclusively to suitably trained and qualified personnel;
- undertakes to inform his personnel in a suitable way about the application and observance of the safety instructions. With that aim, he undertakes to ensure that everyone knows the use and safety instructions for his own duties;
- Personnel must observe all the danger and caution indications shown on the machine.
- Personnel must not carry out, on their own initiative, operations or interventions that are not within their province.
- Personnel must inform their superiors of every problem or dangerous situation that may arise.
- The assembly of parts of other makes, or any modifications, can alter the characteristics of the machine and hence compromise operating safety. The manufacturer therefore declines any and every responsibility for any damage that may be caused by the use of non-original parts.

In addition:



- the user must take all the measures necessary to prevent unauthorised people gaining access to the machine
- the user must inform the manufacturer if faults or malfunctioning of the accident prevention systems are noticed, along with any presumed danger situation
- personnel must always use the personal protective equipment envisaged by legislation and follow the indications given in this manual

3

Technical description of the burner

3.1 Technical data

Model		RS 68/E-EV LN		RS 120/E-EV LN	
Output ⁽¹⁾	High	MBtu/hr kW	1327 - 3258 389 - 955	2282 - 4924 666 - 1443	
	Low	MBtu/hr kW	570 167	1136 333	
Fuel		Natural gas			
Operation		Low - high or modulating			
Standard application		Boilers: water, steam, thermal oil			
Ambient temperature		°F	32 - 104 (0 - 40 °C)		
Combustion air temperature		°F max	140 (60 °C)		
Noise levels ⁽²⁾	Sound pressure	dB(A)	75	77	
	Sound power		86	88	
Weight complete with its packaging		lbs	260		

Tab. A

(1) Reference conditions: Ambient temperature 68 °F (20 °C) - Barometric pressure 394" WC - Altitude 329 ft.

(2) Sound pressure measured in manufacturer's combustion laboratory, with burner operating on test boiler and at maximum rated output. The sound power is measured with the "Free Field" method, as per EN 15036, and according to an "Accuracy: Category 3" measuring accuracy, as set out in EN ISO 3746.

3.2 Electrical data

Model		RS 68/E-EV LN		
Control circuit power supply	V/Ph/Hz	120/1/60		
Main electrical supply (+/-10%)	V/Ph/Hz	208-230/3/60	230/3/60	460/3/60
Electrical power consumption	W max	2460	2550	
Electrical control circuit consumption	W	750		
Total electrical consumption	W	3210	3300	
Electrical protection		NEMA 1		

Model		RS 120/E-EV LN			
Control circuit power supply	V/Ph/Hz	120/1/60			
Main electrical supply (+/-10%)	V/Ph/Hz	208-230/3/60	230/3/60	460/3/60	575/3/60
Electrical power consumption	W max	3225	2550		
Electrical control circuit consumption	W	750			
Total electrical consumption	W	3975	3300		
Electrical protection		NEMA 1			

Tab. B

3.3 Burner models designation

Riello Model and Code	RBNA Model and Code	Main Voltage	Flame safeguard
RS 68/E LN 20166834	RS 68/E LN 20189628	230/3/60	Burner mounted
	RS 68/E LN 20189629	460/3/60	
	RS 68/E LN 20189631	575/3/60	
	RS 68/EV LN 20189632	203/3/60	
	RS 68/EV LN 20189633	460/3/60	
	RS 68/EV LN 20189634	575/3/60	
RS 68/E LN 20167276	RS 68/E LN 20189627	203/1/60	Burner mounted
RS 120/E LN 20166843	RS 120/E LN 20189726	460/3/60	Burner mounted
	RS 120/E LN 20189794	208-230/3/60	
	RS 120/EV LN 20189732	230/3/60	
	RS 120/EV LN 20189735	460/3/60	
RS 120/E LN 20166863	RS 120/E LN 20189795	575/3/60	Burner mounted
	RS 120/EV LN 20189737		

Tab. C

3.4 Burner equipment

The burner is supplied complete with:

- Gas train flange No. 1
- Flange gasket No. 1
- Screws (M10 x 40) to fix the flange No. 4
- Washers for screws M10 No. 4
- Connector for gas pilot line No. 1
- Instruction manuals No. 1



It is recommended to tighten the screws of the gas flange with a tightening torque of **30 Nm ±10%**.

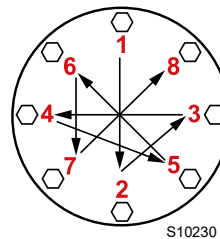

Tighten the nuts gradually (first to 30%, then to 60% up to 100%) according to the cross pattern shown in the figure.

3.5 Burner dimensions

The dimensions of the burner are shown in Fig. 1.

Bear in mind that inspection of the combustion head requires the burner to be opened and the rear part drawn back on the sliding bars.

The dimensions of the open burner are indicated by position U.

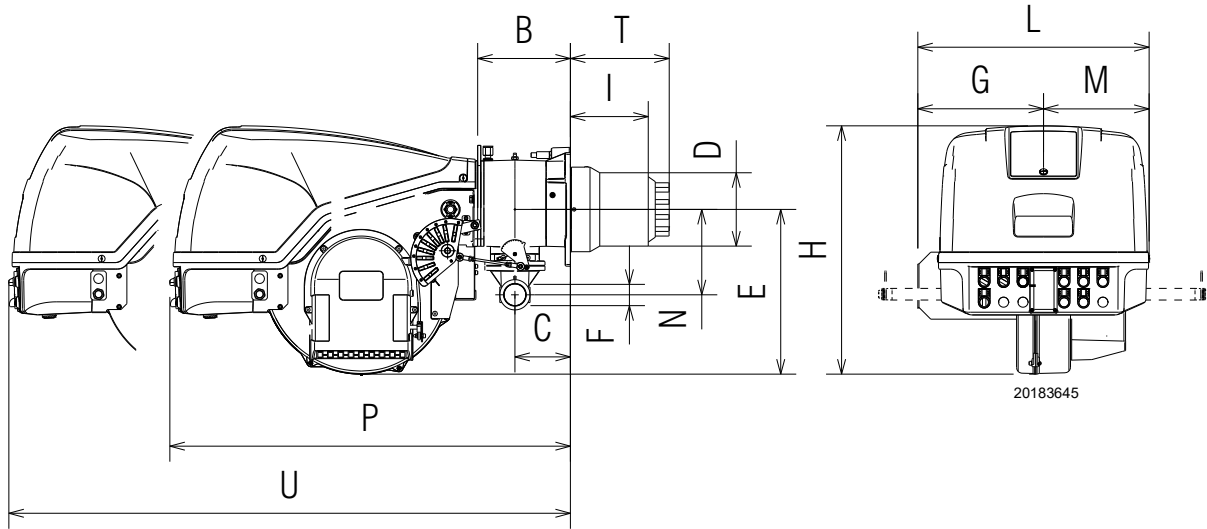

Fig. 1

Inch	B	C	D	E	F	G	H	I	L	M	N	P	T	U
RS 68/E-EV LN	8 25/32	5 5/8	8 37/64	16 47/64	2	12 3/4	25 13/64	7 1/4	23 27/64	10 5/8	8 3/4	40 3/4	9 17/32	63 15/32
RS 120/E-EV LN	8 25/32	5 5/8	8 37/64	16 47/64	2	12 3/4	25 13/64	7 1/4	23 27/64	10 5/8	8 3/4	40 3/4	9 17/32	63 15/32

Tab. D

3.6 Firing rates

The maximum output is chosen within area A of the diagram (Fig. 2).

The **minimum output** must not be lower than the minimum limit of the diagram.



The firing rate was obtained considering a room temperature of 68 °F and an atmospheric pressure of 394 "WC (approx. 0 ft above sea level), with the combustion head adjusted.



In order to utilize also area B (RS 120/E-EV LN), it is necessary to perform the calibration of the combustion head as explained in Fig. 18, page 20.

RS 68/E-EV LN

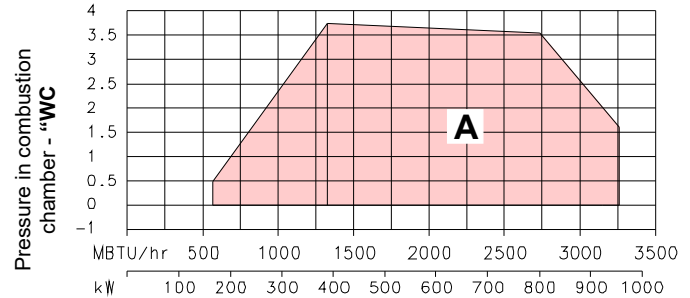

RS 120/E-EV LN

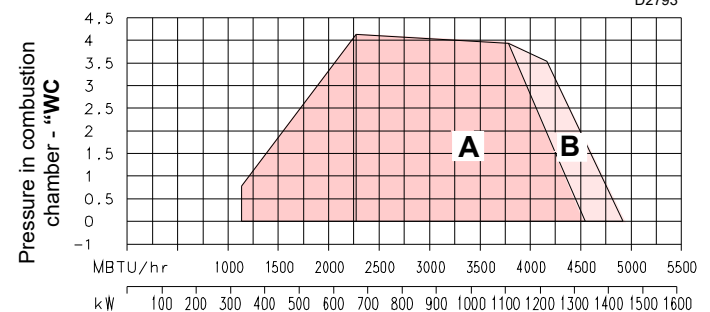

Fig. 2

3.6.1 Procedure to refer burner operating condition at an altitude and/or at a combustion supporter air temperature different to the standard values (328 ft above sea level, 68 °F).

AIR TEMPERATURE

Altitude	Altitude	bar. press.	bar. press.	0	5	10	15	20	25	30	40	°C
ft a.s.l.	m a.s.l.	"w.c.	mbar	32	41	50	59	68	77	86	104	°F
0	0	399	1013,00	1,087	1,068	1,049	1,031	1,013	0,996	0,980	0,948	
328	100	394	1000,00	1,073	1,054	1,035	1,017	1,000	0,983	0,967	0,936	
1.000	305	385	977,40	1,049	1,030	1,012	0,994	0,977	0,961	0,945	0,915	
2.000	610	371	942,80	1,012	0,994	0,976	0,959	0,943	0,927	0,912	0,883	
3.000	915	358	908,20	0,975	0,957	0,940	0,924	0,908	0,893	0,878	0,850	
4.000	1.220	345	875,80	0,940	0,923	0,907	0,891	0,876	0,861	0,847	0,820	
5.000	1.525	332	843,50	0,905	0,889	0,873	0,858	0,844	0,829	0,816	0,790	
6.000	1.830	320	811,85	0,871	0,856	0,841	0,826	0,812	0,798	0,785	0,760	
7.000	2.135	307	779,80	0,837	0,822	0,807	0,793	0,780	0,767	0,754	0,730	
8.000	2.440	294	747,80	0,803	0,788	0,774	0,761	0,748	0,735	0,723	0,700	

Tab. E

F - correction factor of discharge head and delivery in relation to temperature and altitude.

Reference conditions:

- Air temperature 68 °F (20 °C)
- Barometric pressure 394 "w.c. (1000 mbar)
- Altitude 328 ft a.s.l. (100 m a.s.l.)

Example

Using the Tab. E , for an altitude of 3,000 ft and an air temperature of 68 °F, an **F** factor value is obtained equal to 0.908; if the capacity at the boiler furnace is Q_{foc} = 4,500 Mbtu/h, the correct output will be equal to:

$$Q_{burner} = Q_{foc} / F = 4,500 / 0.908 = 4,956 \text{ Mbtu/h}$$

3.7 Minimum furnace dimensions

The firing rates were obtained in special test boilers. Fig. 3 indicates the diameter and length of the test combustion chamber.

Example

Output 2579 MBtu/hr: diameter = 23.6 inch; length 6.6 ft

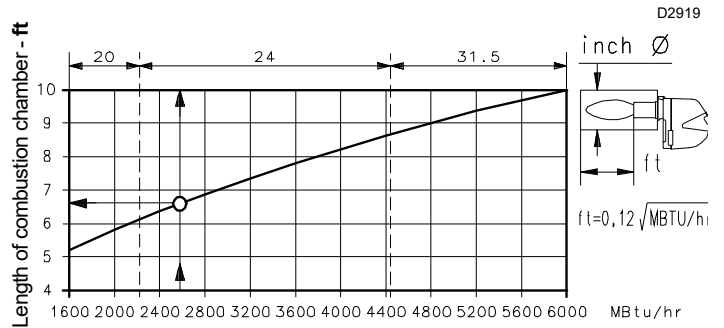

Fig. 3

3.8 Commercial boilers

The RS 68/E-EV LN - RS 120/E-EV LN burners are suitable for operation on either flame-inversion boilers* or boilers with combustion chambers featuring flow from the base (three flue passes) on which the best results are obtained in terms of low NOx emissions. The maximum thickness of the boiler's front door must not exceed 8" (Fig. 4).

(*) For flame inversion boilers, a kit is available to reduce CO emissions if required.

The kit includes 5 gas pipes, identical to the other 5 already fitted to the burner head. In standard conditions, the burner head is fitted with a second group of pipes, with gas outlet in a different direction with respect to the others. With this Kit, the second group of pipes is replaced, so that all the pipes are the same. After fitting the kit, ensure they work correctly by measuring the CO and flue gases emissions.

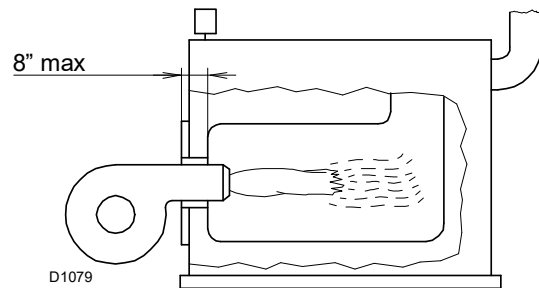

Fig. 4

3.9 Burner description

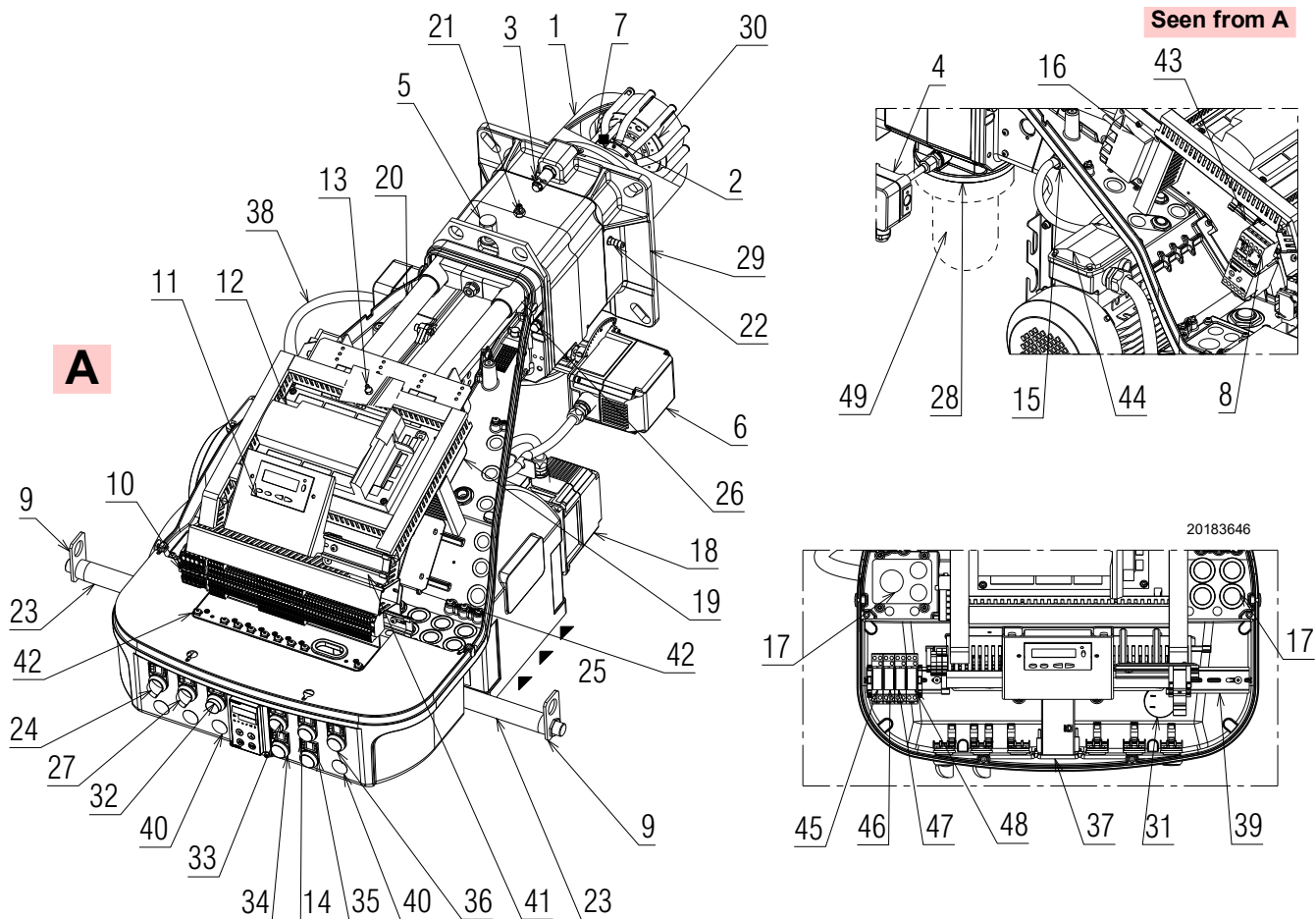

Fig. 5

- | | | | |
|----|---|----|--|
| 1 | Combustion head | 26 | Screws to secure fan to pipe coupling |
| 2 | Burner pilot | 27 | Switch "LOCAL REMOTE" |
| 3 | Screw for combustion head adjustment | 28 | Gas butterfly valve |
| 4 | Maximum gas pressure switch | 29 | Boiler fixing flange |
| 5 | Burner pilot attachment | 30 | Flame stability disc |
| 6 | Gas actuator | 31 | Horn |
| 7 | Ignition electrode | 32 | Button "ALARM SILENCE" |
| 8 | Fan motor contactor and thermal relay with reset button | 33 | Signal "POWER ON" |
| 9 | Lifting ring | 34 | Signal "IGNITION ON" |
| 10 | Terminal board for electrical wiring | 35 | Signal "FUEL ON" |
| 11 | Operator panel with LCD display | 36 | Signal "ALARM ON" |
| 12 | Flame control | 37 | RWF55 modulator |
| 13 | Air pressure switch test point | 38 | High voltage lead |
| 14 | Signal "CALL FOR HEAT" | 39 | Din bar available for accessories |
| 15 | UV flame sensor | 40 | Optional holes |
| 16 | Ignition transformer | 41 | Din bar for fuse holder step-down transformer and OCI 412.10 |
| 17 | Holes for cable grommets for electrical wiring for accessories (to be carried out by the installer) | 42 | Ground terminals |
| 18 | Air actuator | 43 | Din bar for thermal relay, fan motor contactor and available for accessories |
| 19 | Air pressure switch | 44 | Fan motor |
| 20 | Sliding bars for opening the burner and inspecting the combustion head | 45 | k ₁ relay |
| 21 | Gas pressure test point and head fixing screw | 46 | k ₅ relay |
| 22 | Combustion head air pressure test point | 47 | k ₃ relay |
| 23 | Extension sliding bars | 48 | k ₂ relay |
| 24 | Switch "OFF - ON" | 49 | Gas train flange |
| 25 | Fan air inlet | | |

3.10 Flame control (LMV37.4...)

Warning notes



WARNING

To avoid injury to persons, damage to property or the environment, the following warning notes must be observed!

The LMV37.4... is a safety device!

Do not open, interfere with or modify the unit.

Riello S.p.A. will not assume responsibility for any damage resulting from unauthorized interference!

- All activities (mounting, installation and service work, etc.) must be performed by qualified staff.
- Before making any wiring changes in the connection area, completely isolate the plant from mains supply (all-polar disconnection). Ensure that the plant cannot be inadvertently switched on again and that it is indeed dead. If not observed, there is a risk of electric shock hazard.
- Ensure protection against electric shock hazard by providing adequate protection for the burner control's connection terminals.
- Each time work has been carried out (mounting, installation, service work, etc.), check to ensure that wiring and parameters is in an orderly state.
- Fall or shock can adversely affect the safety functions. Such units must not be put into operation, even if they do not exhibit any damage.

Introduction

The flame control for the air/fuel ratio (Fig. 6), (hereafter referred to simply as the flame control), that equips the burners, carries out a series of integrated functions in order to optimise burner functioning, both for single operation and together with other units (e.g. double furnace boiler or more than one generator at the same time).

The basic functions carried out by the flame control relate to:

- flame control;
- the dosage of air and fuel via the positioning (with direct servo-control) of the relative valves, excluding the possible play in the mechanical cam calibration systems;
- the modulation of burner output, on the basis of the load requested by the system, maintaining the pressure or temperature of the boiler at the working values set;
- the safety diagnostic of the air and fuel circuits, via which it is possible to easily identify any causes of malfunctioning.

Mechanical design

The following system components are integrated in the LMV37.4... basic unit:

- Burner control with gas valve proving system
- Electronic air / fuel ratio control
- Control frequency converter air fan
- Modbus interface

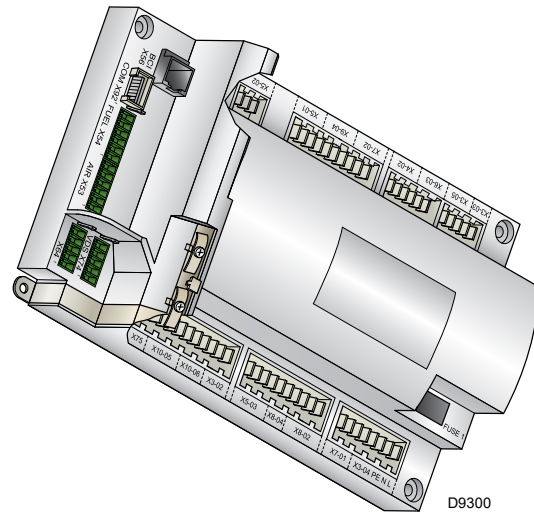

Fig. 6

Installation notes

- Always run high-voltage ignition cables separately while observing the greatest possible distance to the unit and to other cables.
- Do not mix up live and neutral conductors (fire hazard, dangerous failures, loss of protection against electric shock hazard, etc.).
- Do not lay the connecting cable from the LMV37.4... to the AZL2... together with other cables.



WARNING

The first start-up, like every further operation for the internal settings of the flame control, requires access by means of a password and is only to be carried out by personnel of the Technical Assistance Service who have been specifically trained in the internal programming of the tool.

Electrical connection of the flame detectors

It is important to achieve practically disturbance- and loss-free signal transmission:

- Never run the detector cable together with other cables.
 - Line capacitance reduces the magnitude of the flame signal.
 - Use a separate cable.
- Observe the maximum permissible detector cable lengths.
- The ionization probe is not protected against electric shock hazard. It is mains powered and must be protected against accidental contact.
- Locate the ignition electrode and the ionization probe such that the ignition spark cannot arc over to the ionization probe (risk of electrical overloads).

Technical data

LMV37.4... basic unit	Mains voltage	AC 120 V -15 % / +10 %
	Mains frequency	50 / 60 Hz \pm 6 %
	Power consumption	< 30 W (typically)
	Safety class	I, with parts according to II and III to DIN EN 60730-1
Terminal loading 'Inputs'	Unit fuse F1 (internally)	6.3 AT
	Perm. mains primary fuse (externally)	Max. 16 AT
	Undervoltage	
	<ul style="list-style-type: none"> • Safety shutdown from operating position at mains voltage • Restart on rise in mains voltage 	Approx. AC 93 V Approx. AC 96 V
Terminal loading 'Outputs'	Total contact loading:	
	• Nominal voltage	AC 120 V, 50 / 60 Hz
	• Unit input current (safety loop) from:	Max. 5 A
	- Fan motor contactor	
	- Ignition transformer	
	- Valves	
	- Oil pump / magnetic clutch	
	Individual contact loading:	
	Fan motor contactor	
	• Nominal voltage	AC 120 V, 50 / 60 Hz
	• Nominal current	1.6 A pilot duty load declaration to UL372
	• Power factor	$\cos\varphi > 0.4$
	Alarm output	
	• Nominal voltage	AC 120 V, 50 / 60 Hz
	• Nominal current	1 A
	• Power factor	$\cos\varphi > 0.4$
	Ignition transformer	
	• Nominal voltage	AC 120 V, 50 / 60 Hz
• Nominal current	1.6 A pilot duty load declaration to UL372 or 250 VA ignition load declaration to UL372	
• Power factor	$\cos\varphi > 0.2$	
Fuel valves		
• Nominal voltage	AC 120 V, 50 / 60 Hz	
• Nominal current	1.6 A pilot duty load declaration to UL372	
• Power factor	$\cos\varphi > 0.4$	
Operation display		
• Nominal voltage	AC 120 V, 50 / 60 Hz	
• Nominal current	0.5 A	
• Power factor	$\cos\varphi > 0.4$	
Cable lengths	Mains line	Max. 100 m (100 pF/m)
	Display, BCI	For used outside the burner cover or the control panel: Max. 3 m (100 pF/m)
	External lockout reset button	Max. 20 m (100 pF/m)
Environmental conditions	Operation	DIN EN 60721-3-3
	Climatic conditions	Class 3K3
	Mechanical conditions	Class 3M3
	Temperature range	-20...+60 °C
	Humidity	< 95 % r.h.

Tab. F

Operation sequence of the burner

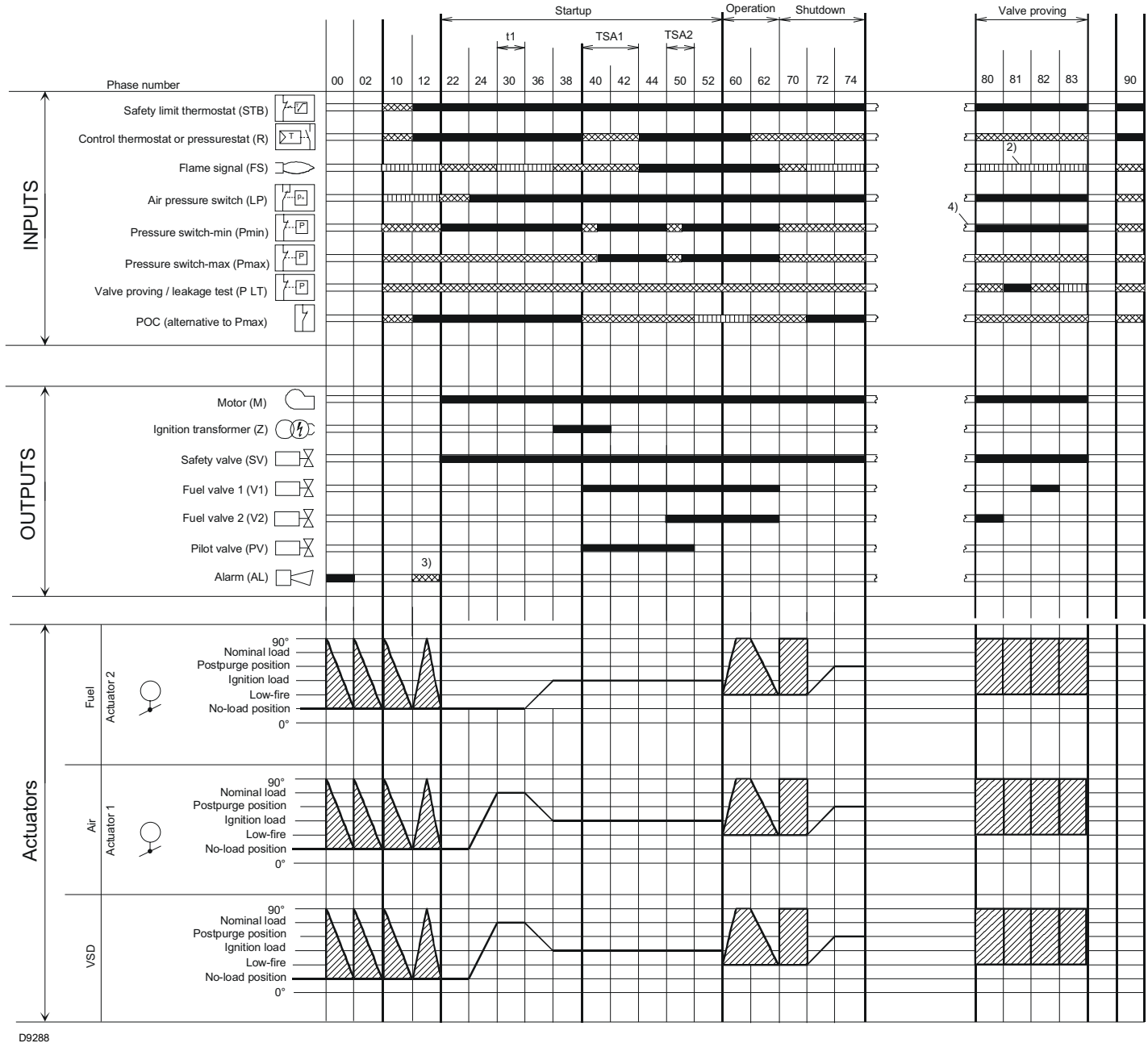





Fig. 7

Legend to the sequence diagrams:

Valve proving takes place depending on the parameter:

- 2) Only with valve proving on startup
- 3) Parameter: with/without alarm in the event of start prevention
- 4) In the event of an erroneous signal on startup, followed by phase 10, otherwise phase 70

- 0° Position as supplied (0°)
- 90° Actuator fully open (90°)

-  Signal ON
-  Signal OFF
-  Any signal is allowed



In standby: after referencing, the actuator is driven to the no-load position

Assignment of times:

- t1 Prepurgation time
- TSA1 Safety time 1 gas / oil
- TSA2 Safety time 2 gas / oil

3.11 Actuators (SQM33.5...)

Warning notes



WARNING

To avoid injury to persons, damage to property or the environment, the following warning notes should be observed!

Do not open, interfere with or modify the actuators!

- All activities (mounting, installation and service work, etc.) must be performed by qualified staff.
- Before making any wiring changes in the connection area of the units, completely isolate the equipment from mains supply (all-polar disconnection). If not observed, there is a risk of electric shock hazard.
- Ensure protection against electric shock hazard by providing adequate protection for the connection terminals and by securing the housing cover.
- After any kind of activity (mounting, installation and service work, etc.), check wiring. Also ensure that the parameters are correctly set.
- Fall or shock can adversely affect the safety functions. Such units must not be put into operation, even if they do not exhibit any damage.



WARNING

The actuator's housing must not be opened. The actuator contains an optical feedback system.

Use

The actuators (Fig. 8) are used to drive and position the air damper and the gas butterfly valve, without mechanical leverages but via the interposition of an elastic coupling.

They are commanded by the flame control, which constantly checks their position by means of a return signal from the optic sensor inside the actuator.

The position (in degrees) of the actuators can be seen on the display of the Operator Panel.

Index "0" for fuel actuator, index "1" for air actuator.

Installation notes

- Always run the high-voltage ignition cables separate from the unit and other cables while observing the greatest possible distance.
- The holding torque is reduced when the actuator is disconnected from power.



WARNING

When servicing or replacing the actuators, take care not to invert the connectors.

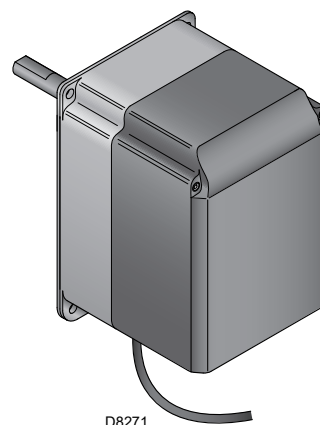

D8271

Fig. 8

Technical data

Operating voltage	AC / DC 24 V ±20 % (load on interface)
Safety class	2 to EN 60 730 part 1 and parts 2...14
Power consumption	max. 10 W
Degree of protection	IP54 to EN 60 529-1
Opening time 0 - 90°	min: 5s, max.: 120s (depending on the type of flame control)
Firing rate	0 - 90°
Cable connection	RAST2,5 connectors
Direction of rotation	Clockwise/anticlockwise (can be selected from the flame control)
Nominal output torque	3 Nm
Holding torque (when live)	3 Nm
Holding torque (when dead)	2.6 Nm
Weight	approx. 1 kg
Environmental conditions:	
Operation	DIN EN 60 721-3-3
Climatic conditions	class 3K5
Mechanical conditions	class 3M4
Temperature range	-20...+60 °C
Humidity	< 95 % r.h.

Tab. 8

4

Installation

4.1 Notes on safety for the installation

After carefully cleaning all around the area where the burner will be installed, and arranging the correct lighting of the environment, proceed with the installation operations.



All the installation, maintenance and disassembly operations must be carried out with the electricity supply disconnected.



The installation of the burner must be carried out by qualified personnel, as indicated in this manual and in compliance with the standards and regulations of the laws in force.



Combustion air inside the boiler must be free from hazardous mixes (e.g.: chloride, fluoride, halogen); if present, it is highly recommended to carry out cleaning and maintenance more frequently.

4.2 Handling

The packaging of the burner includes a wooden platform, so it is possible to move the burner (still packaged) with a transpallet truck or fork lift truck.



The handling operations for the burner can be highly dangerous if not carried out with the greatest attention: keep any unauthorised people at a distance; check the integrity and suitability of the available means of handling.

Check also that the area in which you are working is empty and that there is an adequate escape area (i.e. a free, safe area to which you can quickly move if the burner should fall).

When handling, keep the load at not more than 20-25 cm from the ground.



After positioning the burner near the installation point, correctly dispose of all residual packaging, separating the various types of material.



Before proceeding with the installation operations, carefully clean all around the area where the burner will be installed.

4.3 Preliminary checks

Checking the consignment



After removing all the packaging, check the integrity of the contents. In the event of doubt, do not use the burner; contact the supplier.



The packaging elements (wooden cage or cardboard box, nails, clips, plastic bags, etc.) must not be abandoned as they are potential sources of danger and pollution; they should be collected and disposed of in the appropriate places.



The output of the burner must be within the boiler's firing rate.



A burner label that has been tampered with, removed or is missing, along with anything else that prevents the definite identification of the burner makes any installation or maintenance work difficult.

4.4 Operation position

The burner is designed to operate only in the positions **1**, **2**, **3** and **4** (Fig. 9).

Installation **1** is preferable, as it is the only one that allows the maintenance operations as described in this manual. Installations **2**, **3** and **4** permit operation but make maintenance and inspection of the combustion head more difficult.

Any other position could compromise the correct operation of the appliance.

Installation **5** is prohibited for safety reasons.

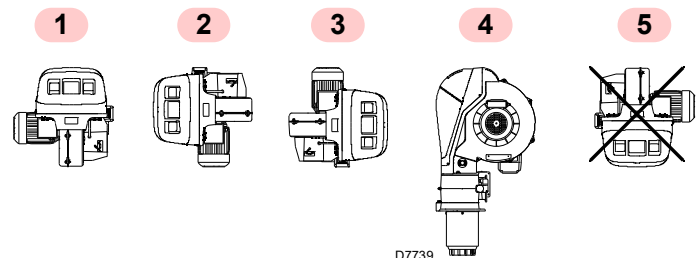

Fig. 9

4.5 Preparing the boiler

4.5.1 Boiler plate

Make holes in the plate shutting off the combustion chamber, as illustrated in Fig. 10.

The position of the threaded holes can be marked using the thermal insulation screen supplied with the burner.

For boilers with front flue passes 13)(Fig. 11) or flame inversion chambers, a protection in refractory material 11) must be inserted between the boiler refractory 12) and the blast tube 10). This protection must not compromise the extraction of the blast tube.

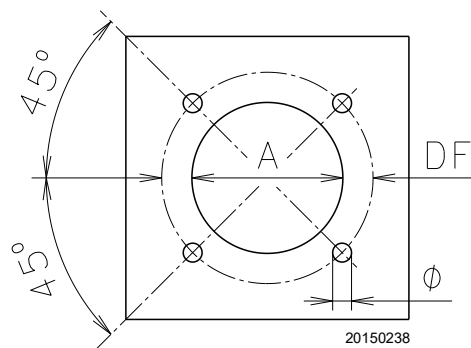

Fig. 10

inch	A	DF	Ø
RS 68/E-EV LN	9 1/16	12 25/32 - 14 1/2	5/8 W
RS 120/E-EV LN	9 1/16	12 25/32 - 14 1/2	5/8 W

Tab. H

4.6 Securing the burner to the boiler

Secure the burner to the boiler, fixing the flange 9)(Fig. 11) to the boiler plate and interposing the insulating gasket 8).

Use the 4 screws, with a tightening torque of 26-29 Lbf. ft, after protecting their thread with anti-seize products.

After the start-up, check there is no leakage of flue gases into the external environment.



The seal between burner and boiler must be airtight.

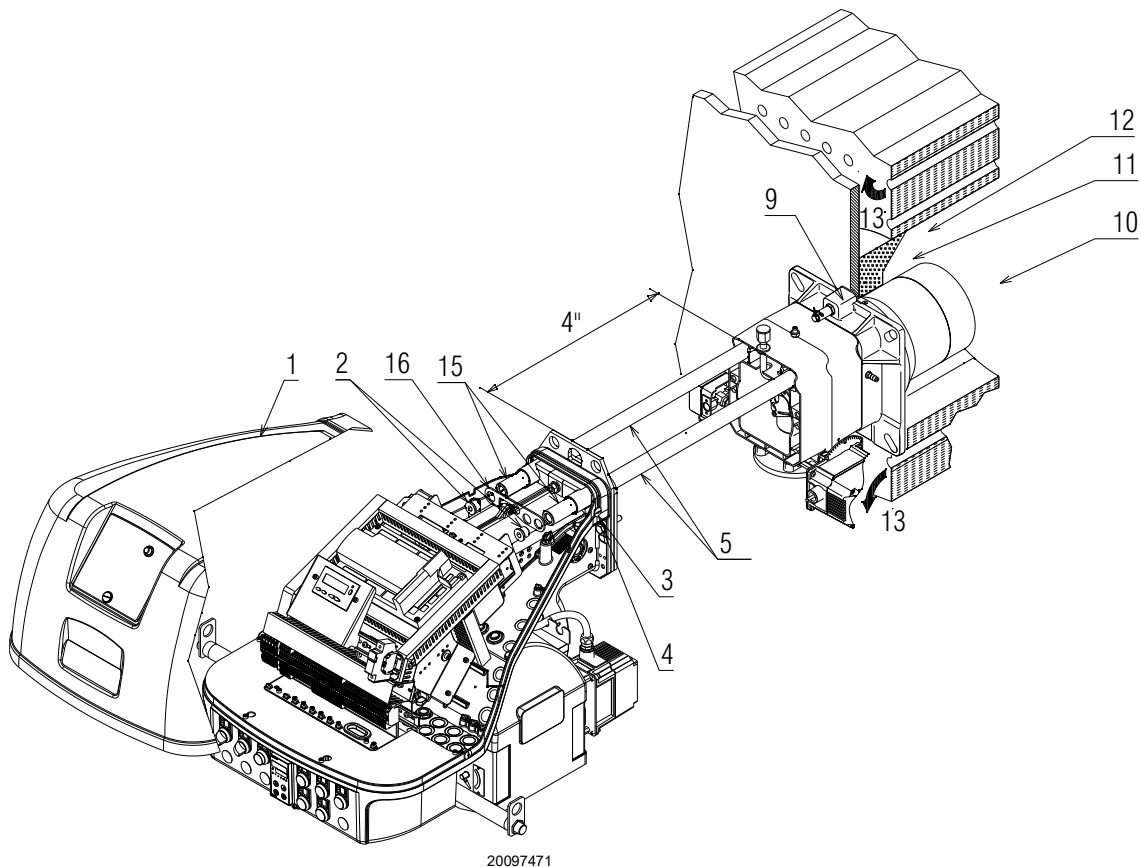

Fig. 11

4.7 Electrode positioning

To verify the correct position of the ignition electrode (Fig. 12), you need to separate the combustion head from the rest of the burner.



Measures must be respected (Tab. I).

inch	A	B
RS 68/E-EV LN	$1/8 \div 3/16$	$1 \ 7/8$
RS 120/E-EV LN	$1/8 \div 3/16$	$1 \ 13/16$

Tab. I

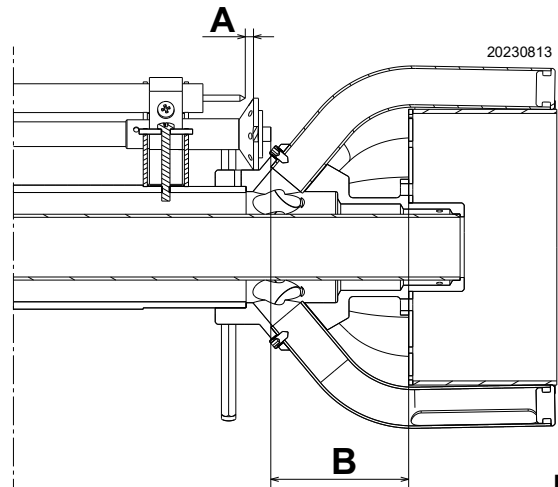

Fig. 12

4.8 Combustion head calibration

At this point check, for model RS 120/E-EV LN, whether the maximum delivery of the burner at high fire operation is contained in area A or in area B of the firing rate. See Fig. 2, page 8.

If it is in area A then no operation is required. If on the other hand, it is in area B, before starting the burner remove the 4 circular sectors 1)(Fig. 13) fastened behind the stabilizing disc by removing the 8 screws 2)(Fig. 13).

Detach the combustion head from the burner, (Fig. 11):

- loosen the 4 screws 3) and remove the cover 1);
- remove the screws 2) from the slide bars 5);
- remove the 2 screws 4) and pull the burner back on slide bars 5) by about 4";
- install the extension bars 15)(Fig. 11, page 17) and re-screw the screws 2) including the safety plate 16);
- disconnect the electrode wires and then pull the burner completely off the slide bars.

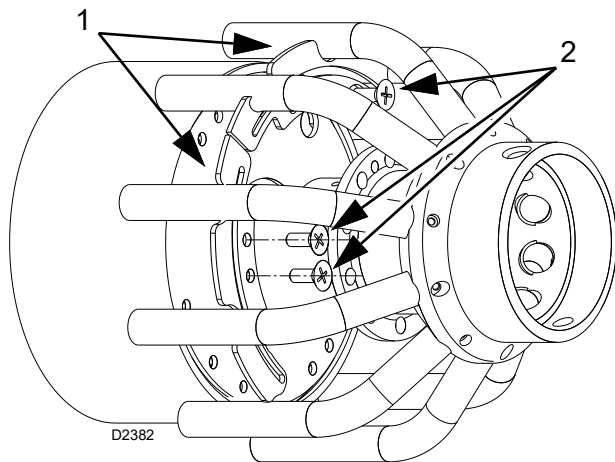

Fig. 13

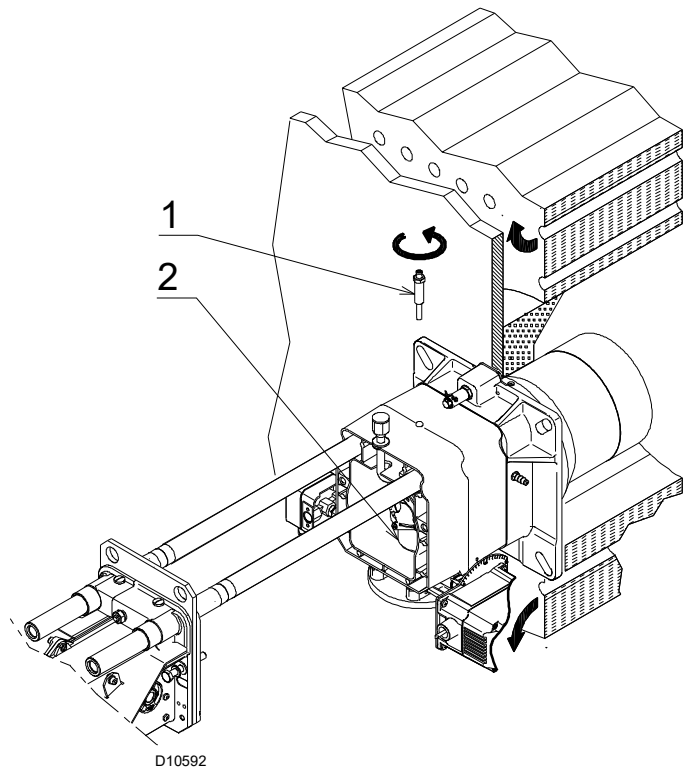

Fig. 14

4.9 Adjustment of the combustion head

At this point of the installation, the combustion head is fixed to the boiler as shown in Fig. 14.

It is therefore especially easy to adjust, and this adjustment depends only on the maximum output of the burner.

Two adjustments of the head are foreseen:

- air adjustment R1
- gas adjustment R2

In the diagram of Fig. 15, find the notch at which to adjust both air and central gas/air.

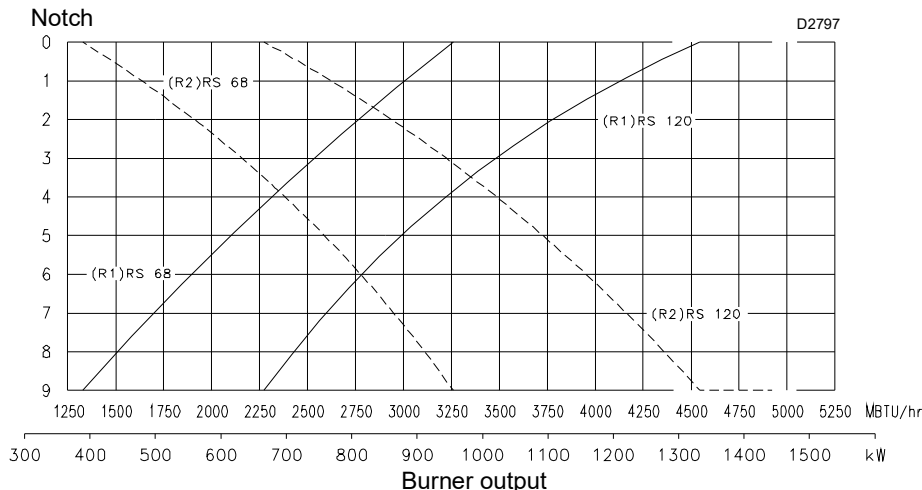

Fig. 15

4.9.1 Air adjustment

Turn screw 4)(Fig. 16) until the notch identified is aligned with the front surface 5)(Fig. 16) of the flange.



To facilitate adjustment, loosen the screw 3)(Fig. 16), adjust and then lock.

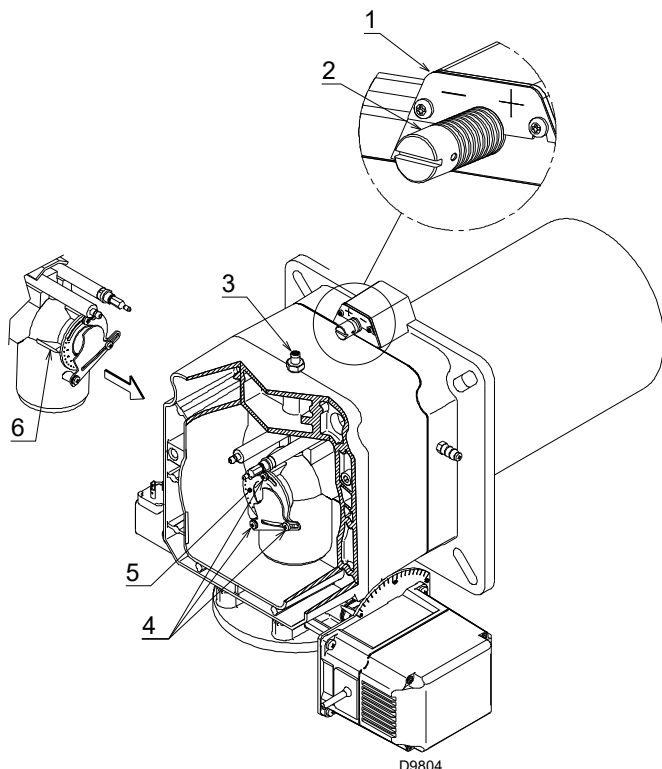

Fig. 16

4.9.2 Gas adjustment

- Loosen the 3 screws 4)(Fig. 16) and turn ring 5) until the notch identified is aligned with index 6).
- Tighten the 3 screws 1) fully down.

Example

RS 120/E LN, burner output = 3750 MBtu/hr

If we consult diagram (Fig. 15) we find that for this output the adjustments are:

- air: R1 = notch 2;
- gas: R2 = notch 5.

Note

Diagram (Fig. 15) indicates an optimal regulation for a type of boiler seen in Fig. 3, page 10.

If the pressure of gas allows it, by closing ring nut (Fig. 3, page 10) a reduction of the formation of NOx is obtained.

Continuing with the previous example, (Fig. 25, page 24) indicates that for burner with output of 3750 MBtu/hr a pressure of approximately 2.8" is necessary at test point 3)(Fig. 16). If this pressure cannot be reached, open the ring 5)(Fig. 16) to notch 4 or 5.

Make sure that the combustion characteristics are satisfactory and free of pulsations.

4.10 Burner refitting

Once the combustion head adjustment is completed:

- push the burner on the sliding bars 3) at approximately 4" from the pipe coupling 4) - burner in the position shown in Fig. 17;
- insert the electrode cable, then slide the burner as far as the pipe coupling - burner in the position shown in Fig. 18;
- unscrew the 2 screws 2) from the extension 5) and reposition them as previously Fig. 18.
- refit the screws 2) on the sliding bars 3);
- fix the burner to the pipe coupling with the screws 1).

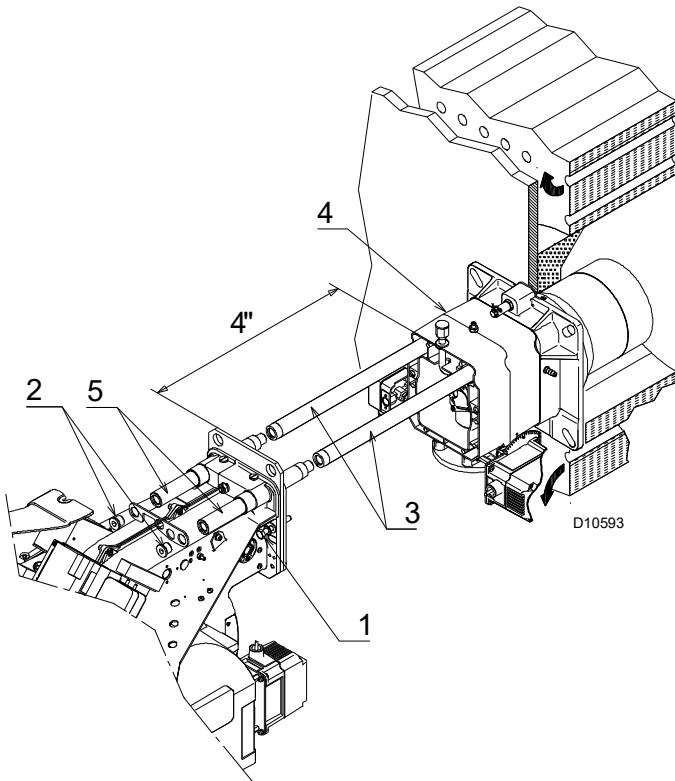
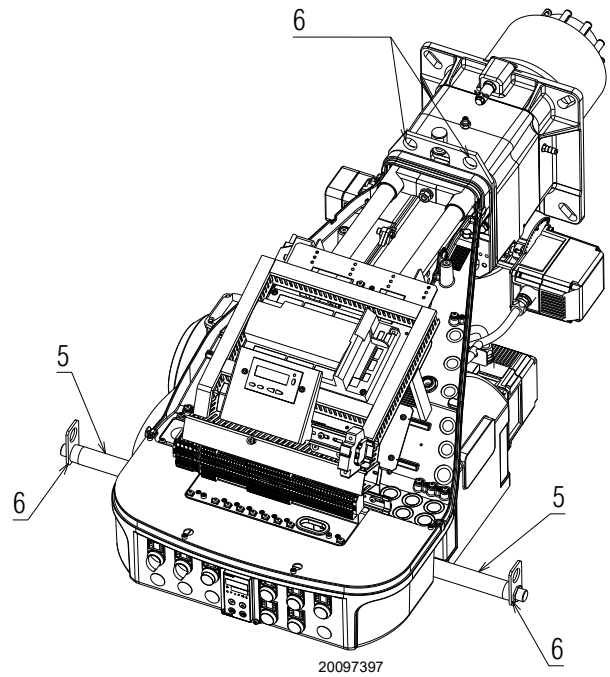

Fig. 17



WARNING

When fitting the burner on the two sliding bars, it is advisable to gently draw out the high voltage cable until it is slightly taut.



- 5) Extension sliding bars
- 6) Lifting rings

Fig. 18

4.11 Gas supply



Explosion danger due to fuel leaks in the presence of a flammable source.

Precautions: avoid knocking, attrition, sparks and heat.

Make sure that the fuel interception tap is closed before performing any operation on the burner.



WARNING

The fuel supply line must be installed by qualified personnel, in compliance with current standards and laws.

4.11.1 Gas train



DANGER

Disconnect the electrical power using the main system switch.



Check that there are no gas leaks.



Beware of train movements: danger of crushing of limbs.



Make sure that the gas train is properly installed by checking for any fuel leaks.



The operator must use appropriate tools for installation.

Gas train assembly

- The gas train is type-approved according to standard UL 795 and is supplied separately from the burner.
- The gas train can enter the burner from the right or left side, depending on which is the most convenient, see Fig. 19.
- The gas train must be connected to the gas attachment 1)(Fig. 19) with the flange 2), the gasket 3) and the screws 4) supplied with the burner.
- The gas solenoids must be as close as possible to the burner, to ensure that the gas reaches the combustion head within the safety time of 3s.
- Ensure that the maximum pressure necessary for the burner is included in the calibration field of the pressure regulator (color of the spring).
- The pilot gas train must be connected to the gas attachment 5)(Fig. 19) and can enter the burner from the right or left side.



WARNING

See the accompanying instructions for the adjustment of the gas train.

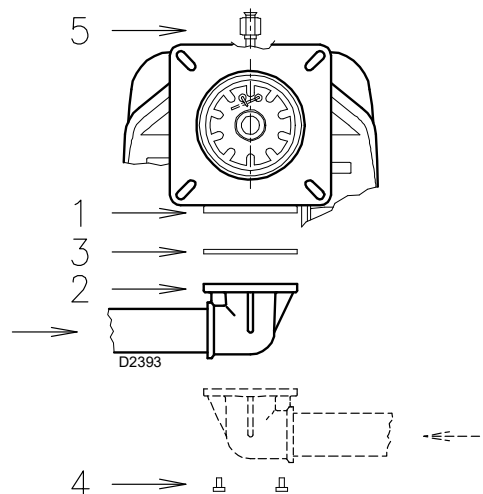

Fig. 19

4.11.2 Gas feeding line

It must be type-approved according to required standards and is supplied separately from the burner.

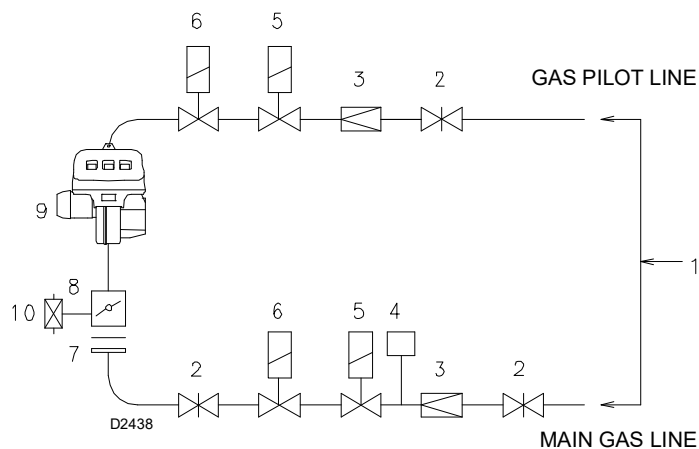

Fig. 20

Key (Fig. 20)

- 1 Gas input pipe
- 2 Manual valve
- 3 Pressure regulator
- 4 Minimum gas pressure switch
- 5 1st safety shut off valve
- 6 2nd safety shut off valve
- 7 Standard issue burner with flange gasket
- 8 Gas adjustment butterfly valve (*)
- 9 Burner
- 10 Maximum gas pressure switch (*)

(*) On the burner

4.11.3 Gas valve electrical connections



Connections must be respected.



Pay attention to the terminals during the connection of the valves. The correct terminals are the orange ones, as shown in Fig. 22-A.

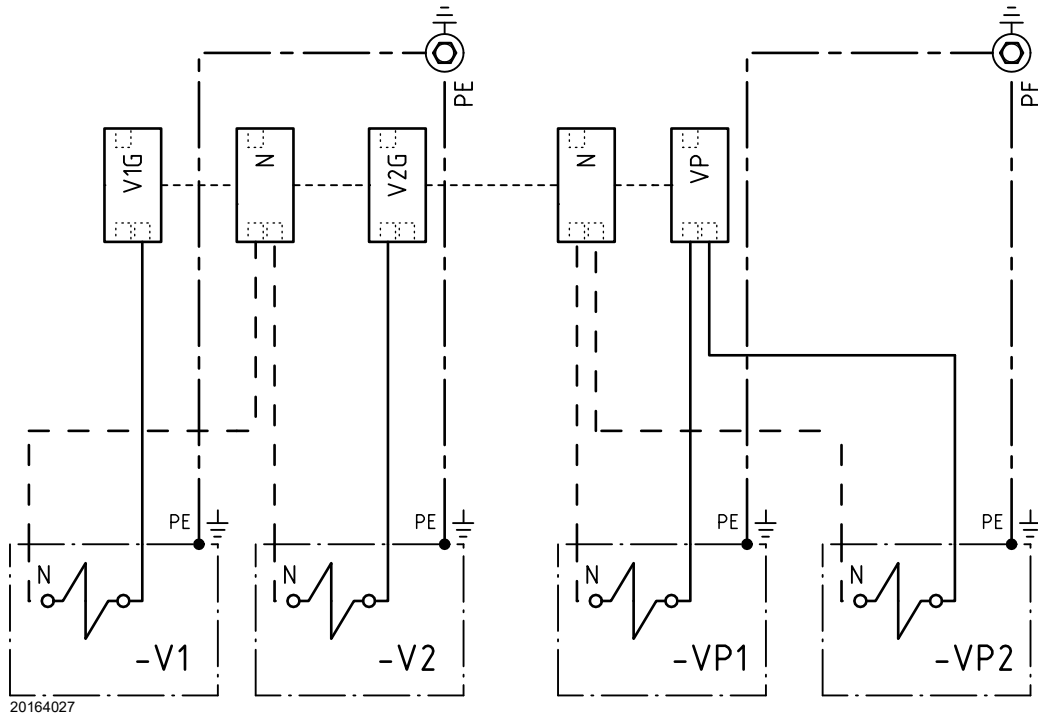

20164027

Fig. 21

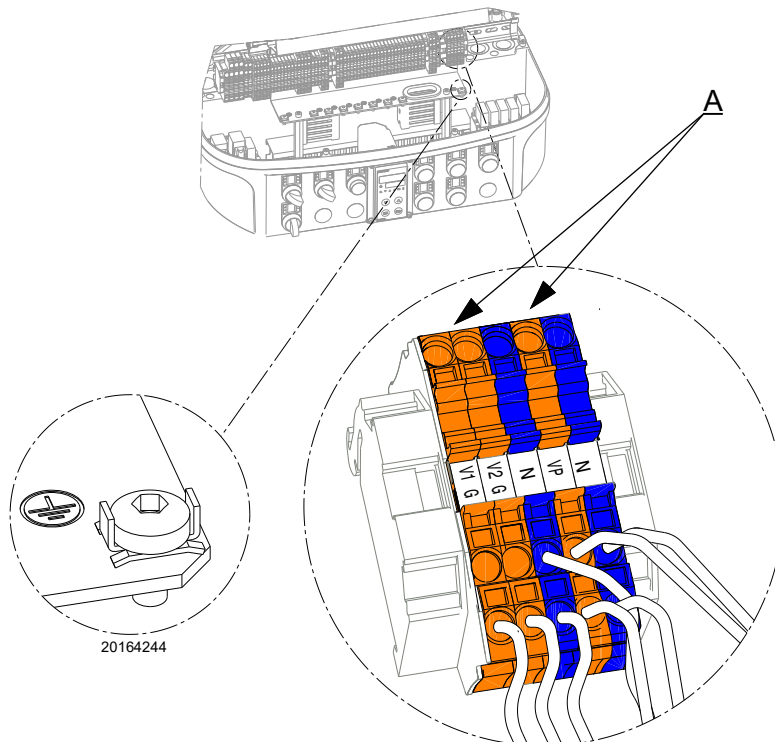

Fig. 22



In case of installation of the vent valves (VV and VV1), the configuration will be that shown in Fig. 23.

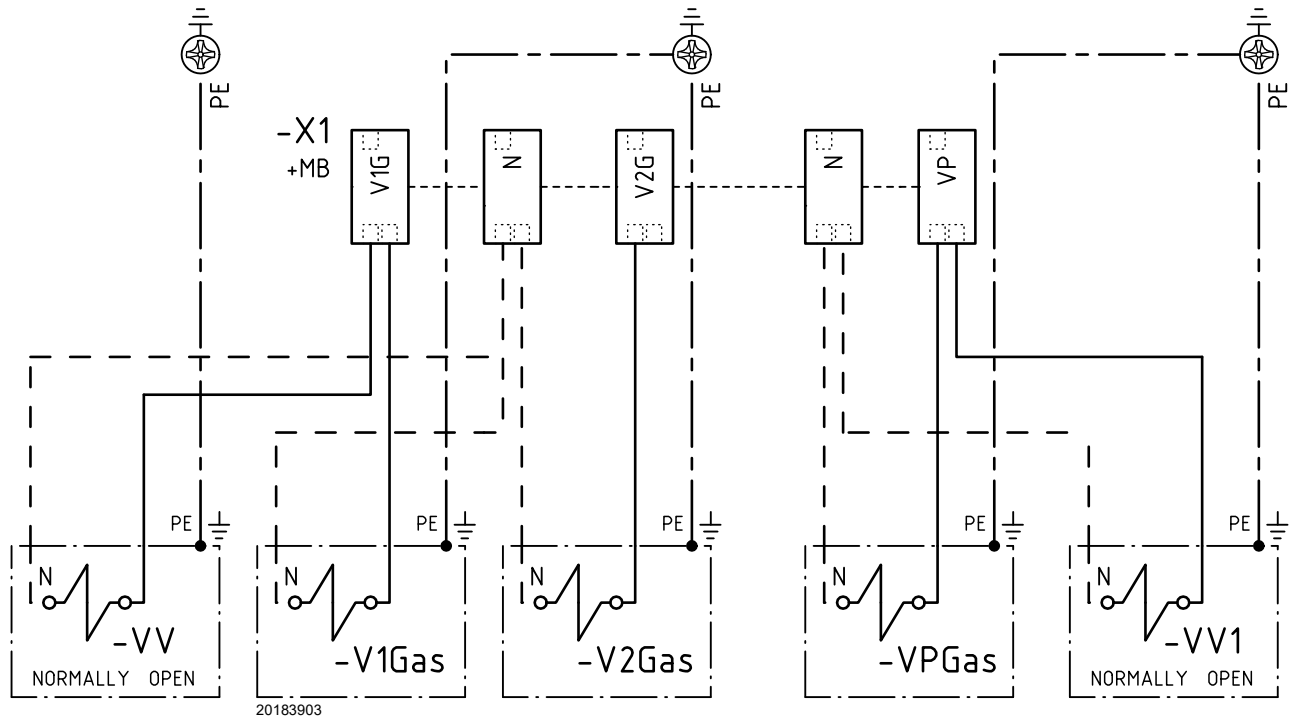

Fig. 23

4.12 Gas supply pressure

The diagram (Fig. 25) show minimum load losses at combustion head depending on the maximum burner output operation with natural gas (G 20).

Gas pressure is measured at the test point 1)(Fig. 24), with:

- Combustion chamber at 0 mbar
- Burner working at maximum output
- Ring nut 2)(Fig. 16) adjusted as in the diagram of Fig. 15

NOTE

To know the approximate output at which the burner is operating at its maximum:

- subtract the combustion chamber pressure from the gas pressure measured at test point 1)(Fig. 24);
- find, in the diagram (Fig. 25) the pressure value closest to the result you want;
- read the corresponding output on the left.

Example for RS 120/E LN

- Maximum output operation
- Natural gas
- Gas ring 2)(Fig. 16, page 19) adjust as indicated in diagram Fig. 15, page 19
- Gas pressure at test point 1)(Fig. 24) = 5.11 "WC
- Pressure in combustion chamber = 1.18 "WC
- 5.11 - 1.18 = 3.93 "WC

A maximum output of 3030 MBtu/hr shown diagrams RS 120/E LN corresponds to 3.93 "WC pressure.

This value serves as a rough guide, the effective delivery must be measured at the gas meter.

NOTE

To know the required gas pressure at test point 1)(Fig. 24), set the maximum output required from the burner operation, then:

- find the nearest output value in the table for the burner in question.
- read, on the diagram (Fig. 25), the pressure test point 1)(Fig. 24);
- add this value to the estimated pressure in the combustion chamber.

Example for RS 120/E LN

- Maximum output required: 3750 MBtu/hr
- Ring nut 2)(Fig. 16) adjusted as in the diagram of Fig. 15
- Gas pressure at output of 2815 MBtu/hr = 6 "WC
- Pressure in combustion chamber = 1.18 "WC
- 6 + 1.18 = 7.15 "WC

pressure required at pressure test point 1)(Fig. 24).

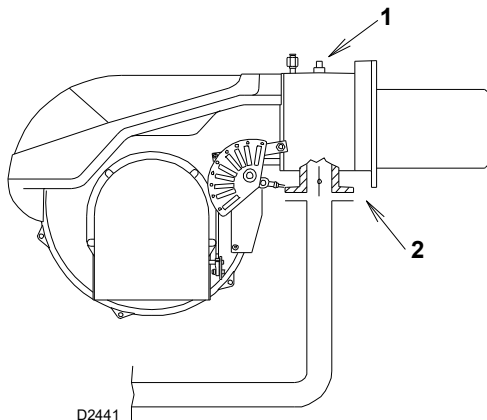
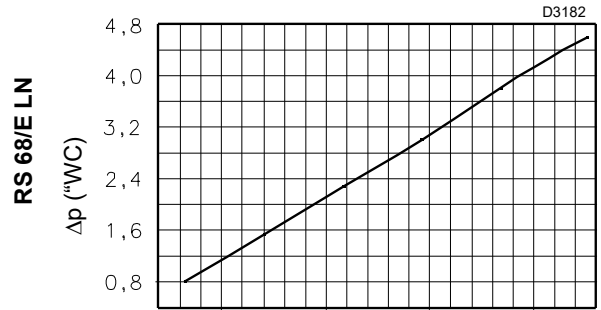
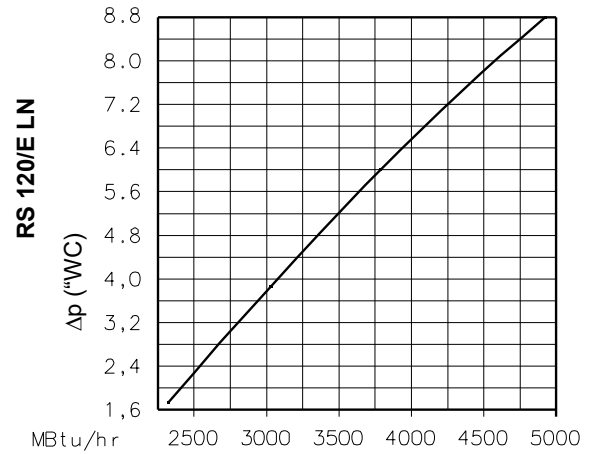

Fig. 24



RS 68/E LN
Δp ("WC)
MBtu/hr
kW
Burner output operation



RS 120/E LN
Δp ("WC)
MBtu/hr
kW
Burner output operation

Fig. 25

Δp "wc gas butterfly 2)(Fig. 24)

RS 68/E LN		
MBtu/hr	kW	Δp "WC
1194	350	0.04
1365	400	0.04
1535	450	0.04
1706	500	0.1
1877	550	0.1
2047	600	0.1
2218	650	0.1
2388	700	0.1
2559	750	0.2
2730	800	0.2
2934	860	0.2
3071	900	0.2
3241	950	0.2

RS 120/E LN		
MBtu/hr	kW	Δp "WC
2047	600	0.1
2218	650	0.1
2440	715	0.2
2593	760	0.2
2815	825	0.2
3037	890	0.2
3258	955	0.2
3480	1020	0.3
3719	1090	0.3
3992	1170	0.3
4265	1250	0.4
4335	1300	0.5
4606	1350	0.5
4777	1400	0.5



The data of thermal output and combustion head gas pressure are related to full open (90°) gas butterfly valve.

4.13 Electrical wiring

Notes on safety for the electrical wiring



DANGER

- The electrical wiring must be carried out with the electrical supply disconnected.
- Electrical wiring must be carried out by qualified personnel and in compliance with the regulations currently in force in the country of destination.
- The Manufacturer declines all responsibility for modifications or connections different from those shown in the electrical layouts.
- Check that the electrical supply of the burner corresponds to that shown on the identification label and in this manual.
- Do not invert the neutral with the phase in the electrical supply line. Any inversion would cause a lockout due to firing failure.
- The electrical safety of the device is obtained only when it is correctly connected to an efficient earthing system, made according to current standards. It is necessary to check this fundamental safety requirement. In the event of doubt, have the electrical system checked by qualified personnel. Do not use the gas tubes as an earthing system for electrical devices.
- The electrical system must be suitable for the maximum input power of the device, as indicated on the label and in the manual, checking in particular that the section of the cables is suitable for the input power of the device.
- For the main power supply of the device from the electricity mains:
 - do not use adapters, multiple sockets or extensions;
 - use an omnipolar switch with an opening of at least 1/8" (overvoltage category) between the contacts, as indicated by the current safety standards.
- Do not touch the device with wet or damp body parts and/or in bare feet.
- Do not pull the electric cables.

Before carrying out any maintenance, cleaning or checking operations:



DANGER

disconnect the electrical supply from the burner by means of the main system switch;



DANGER

close the fuel interception tap;



DANGER

avoid condensate, ice and water leaks from forming.

If the cover is still present, remove it and proceed with the electrical wiring.

All the cables to be connected to the burner are fed through the grommets. See figure on the right.

The use of the cable grommets can take various forms. By way of example we indicate the following mode (according to **UL795**):

- A Fan motor
- B Maximum gas pressure switch
- C Flame sensor
- D Air servomotor
- E Gas servomotor
- F Air pressure switch
- 1 Three phase power supply with 3/4 inch cable grommet.
- 2 Available: single phase power supply and other devices with 1/2 inch cable grommet
- 3 Available: consents/safety, minimum gas pressure switch, gas valves and other devices with 3/8 inch cable grommet
- 4 Available hole for M16
- 5 Available for ground terminals.



WARNING

The control panel is in compliance with UL508A.

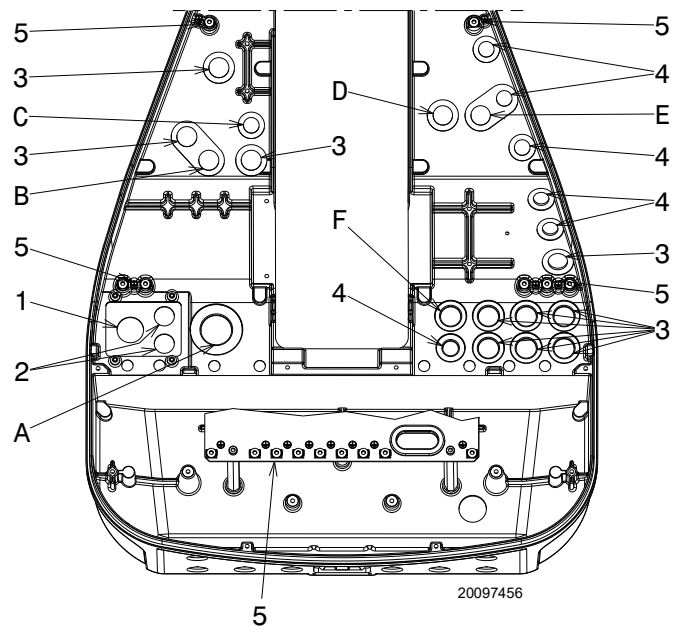

Fig. 26



After carrying out maintenance, cleaning or checking operations, reassemble the hood and all the safety and protection devices of the burner.

4.14 Overload relay calibration

Depending on the burner type, there are two different overload relays:

- electro-mechanical overload relay (used for single phase motors);
- electronic thermal relay (used for three phase motors).

4.14.1 Electro-mechanical overload relay

The electro-mechanical overload relay (Fig. 27) is used to avoid damage to the motor owing to a strong increase in absorption or the lack of a phase.

For the calibration, refer to the table given in electrical layout. If the minimum value of the scale of the overload relay is greater than the rating absorption of the motor, protection is still ensured.

- To reset, in the case of an intervention of the overload relay, press the button "RESET" (Fig. 27).
- The button "STOP" (Fig. 27) opens the NC (95-96) contact and stops the motor.

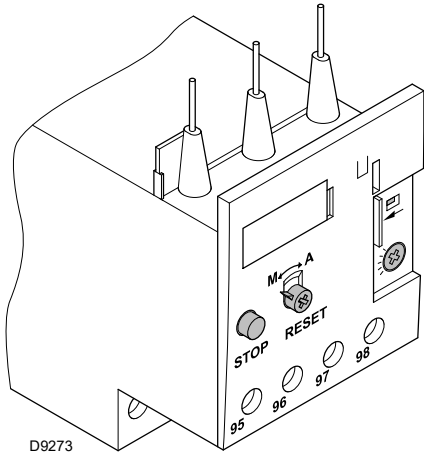

Fig. 27

- To test the overload relay, insert a screwdriver in the window "TEST" (Fig. 28) and move it in the sense of the arrow (towards right).



Automatic resetting can be dangerous.

This action is not provided for the burner operation.

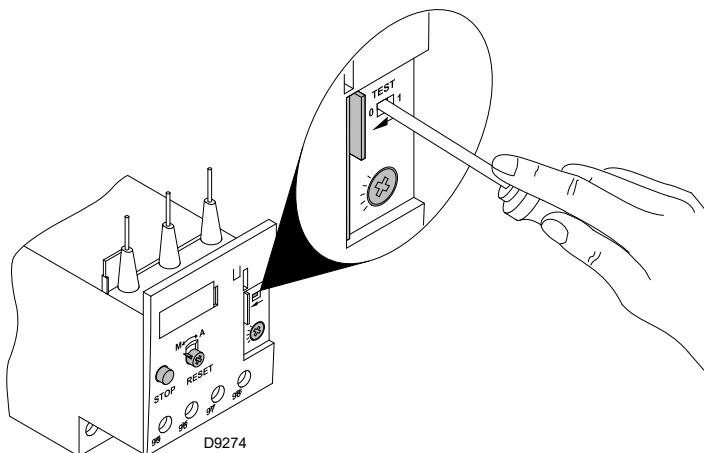

Fig. 28

4.14.2 Electronic relay

- To reset, in the case of an intervention of the electronic relay, press the button "RESET" (Fig. 29).

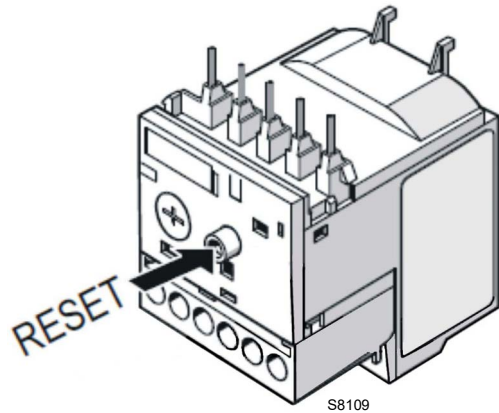

Fig. 29

There are two different solution to test the electronic relay:

- **Device test (Fig. 30)**
Push slowly the button in the window with a little screwdriver.

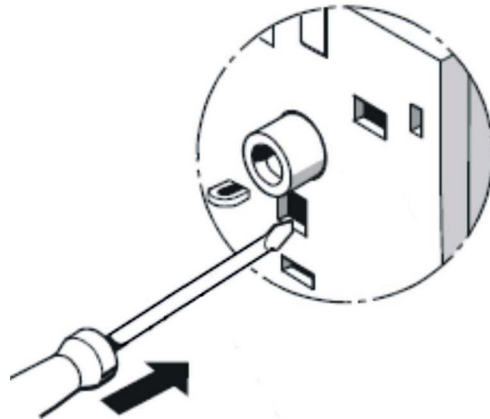

Fig. 30

- **Contact test NC (95-96) and NO (97-98)(Fig. 31)**
Insert in the window a little screwdriver and move it in the sense of the arrow.

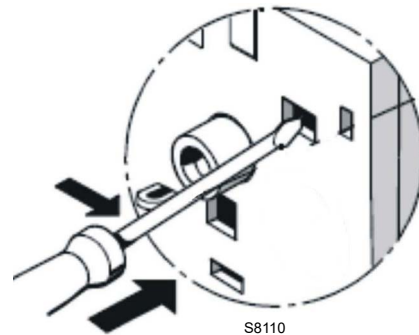

Fig. 31

4.15 Motor connection at 208-230 or 460V

WARNING:
the motors, manufactured for 208-230/460 **IE3 NEMA Premium Efficiency** voltage, have the same connection than **IE2/Epact** motors.

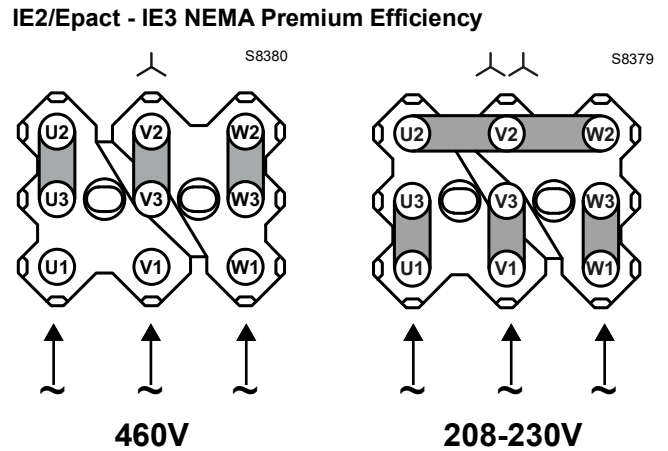

Fig. 32

4.16 Motor connection at 575V

WARNING:
the motors, manufactured for 575V **IE3 NEMA Premium Efficiency** voltage, have the same flame control base of the **IE1** and **IE2/Epact** motors.
Please pay attention to the indications in case of maintenance or substitution.

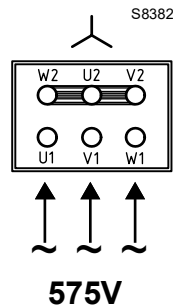

Fig. 33

4.17 Motor rotation

As soon as the burner starts up, go in front of the cooling fan of the fan motor and check it is rotating anticlockwise (Fig. 34).

If this is not the case:

- set the burner switch to "0" (OFF) and wait for the flame control to carry out the switch-off phase.



Disconnect the electrical supply from the burner by means of the main system switch.

- Invert the phases on the three-phase motor power supply.

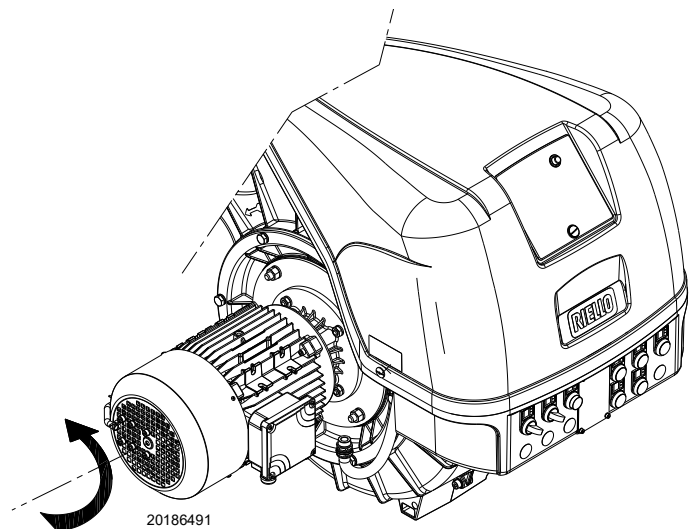

Fig. 34

5

Start-up, calibration and operation of the burner

5.1 Notes on safety for the first start-up



The first start-up of the burner must be carried out by qualified personnel, as indicated in this manual and in compliance with the standards and regulations of the laws in force.



Check the correct working of the adjustment, command and safety devices.



Refer to paragraph “Safety test - with gas ball valve closed” on page 31 before the first start-up.

5.2 Operations before start-up

- Ensure that the gas supply company has carried out the supply line vent operations, eliminating air or inert gases from the piping.
- Slowly open the manual valves situated upstream of the gas train.
- Adjust the minimum gas pressure switch to the start of the scale.
- Adjust the maximum gas pressure switch to the end of the scale.
- Adjust the air pressure switch to the start of the scale.
- Purge the air from the gas line. Fit a U-type manometer (Fig. 35) to the gas pressure test point on the sleeve. The manometer readings are used to calculate the MAX. burner power using the diagram on page 24.

Before starting up the burner it is good practice to adjust the gas train so that ignition takes place in conditions of maximum safety, i.e. with gas delivery at the minimum.

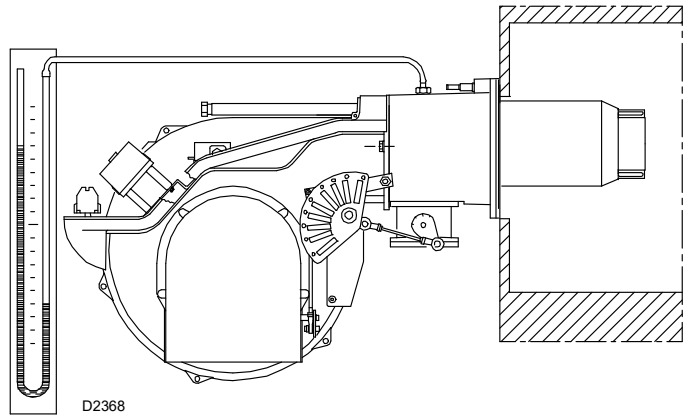

Fig. 35

5.3 Burner start-up

Feed electricity to the burner via the disconnecting switch on the boiler panel.

Close the thermostats/pressure switches, set the parameters on the RWF 55 regulator. Please refer to the specific manual for this operation. Turn the switch of Fig. 36 to position “ON” and turn the switch of Fig. 36, page 28 to position “LOCAL”.



Make sure that the lamps or testers connected to the solenoids, or indicator lights on the solenoids themselves, show that no voltage is present. If voltage is present, stop the burner **immediately** and check the electrical wiring. When the burner starts, check the direction of the motor rotation, as indicated in Fig. 36, page 28.

As the burner is not fitted with a device to check the sequence of the phases, the motor rotation may be incorrect. As soon as the burner starts up, go in front of the cooling fan of the fan motor and check it is rotating anticlockwise. See Fig. 36.

If this is not the case:

- place the switch of Fig. 36, page 28 in position “0” and wait for the flame control to carry out the switch-off phase;
- disconnect the electrical supply from the burner;
- invert the phases on the three-phase power supply.

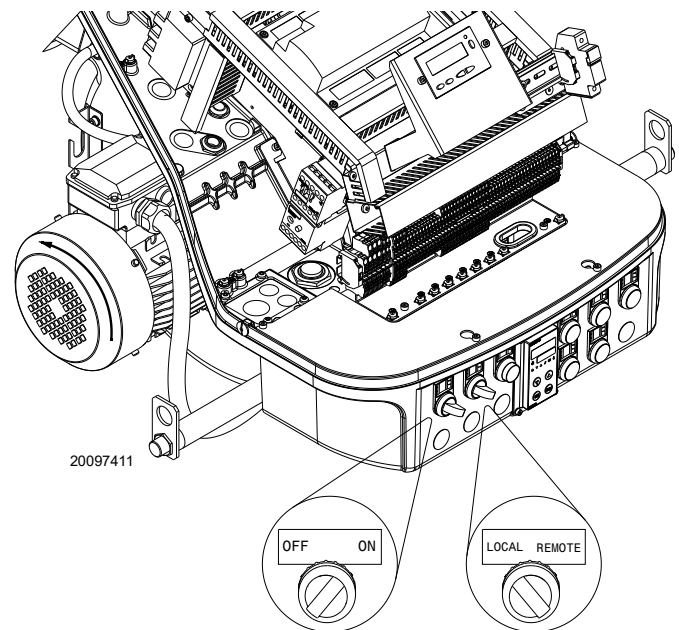

Fig. 36



For the start-up procedure and the parameters calibration, refer to the specific instruction manual of the LMV37... electronic cam supplied with the burner.

5.4 Adjusting gas/air delivery



- Move slowly towards the maximum output (butterfly gas valve completely open);
- adjust the required maximum output with the gas pressure stabilizer;
- adjust the combustion parameters with the air servomotor and store the maximum combustion point.

Complete the procedure slowly, synchronizing the combustion with the two servomotors and storing the different setting points.

5.5 Final calibration of the pressure switches

5.5.1 Air pressure switch

The air pressure switch is connected in differential (Fig. 37) and is activated by both the negative pressure of the air intake and the air pressure from the fan.

Adjust the air pressure switch (Fig. 38) after having performed all other burner adjustments with the air pressure switch set to the min. of the scale.

With the burner operating at low fire, adjust the pressure switch by slowly turning the relative knob clockwise until the burner locks out.

Then turn the knob counter-clockwise about 20% of the set point and start-up the burner again to ensure the set point is correct.

If the burner locks out again, turn the knob counter-clockwise a little bit more.

5.5.2 Maximum gas pressure switch

Adjust the maximum gas pressure switch (Fig. 39) after making all other burner adjustments with the maximum gas pressure switch set to the end of the scale.

To calibrate the maximum gas pressure switch, open the tap and then connect a pressure gauge to its pressure test point.

The maximum gas pressure switch must be regulated to a value no higher than 30% of the measurement read on the gauge when the burner is working at maximum output.

After making the adjustment, remove the pressure gauge and close the tap.

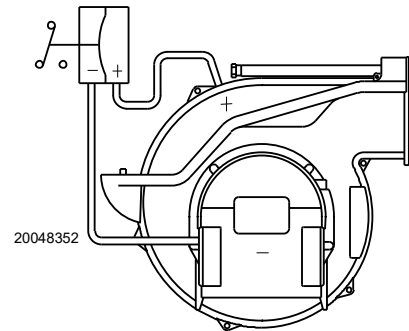

Fig. 37



Fig. 38

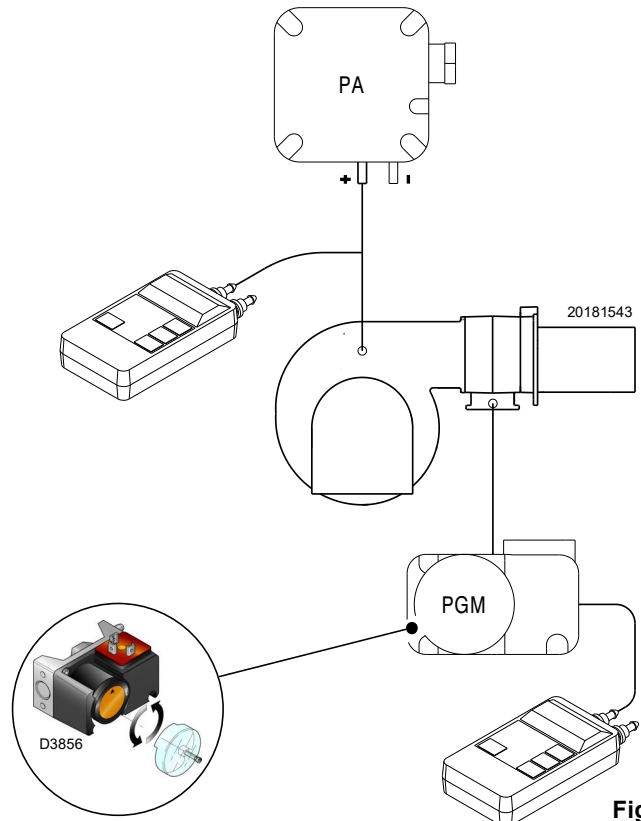

Fig. 39

5.5.3 Minimum gas pressure switch

The purpose of the minimum gas pressure switch is to prevent the burner from operating in an unsuitable way due to too low gas pressure.

Adjust the minimum gas pressure switch (Fig. 40) after having adjusted the burner, the gas valves and the gas train stabiliser. With the burner operating at maximum output:

- install a pressure gauge downstream of the gas train stabiliser (for example at the gas pressure test point on the burner combustion head);
- choke slowly the manual gas cock until the pressure gauge detects a decrease in the pressure read of about 0.1 kPa (1 mbar). In this phase, verify the CO value which must always be less than 100 mg/kWh (93 ppm).
- Increase the adjustment of the gas pressure switch until it intervenes, causing the burner shutdown;
- remove the pressure gauge and close the cock of the gas pressure test point used for the measurement;
- open completely the manual gas cock.

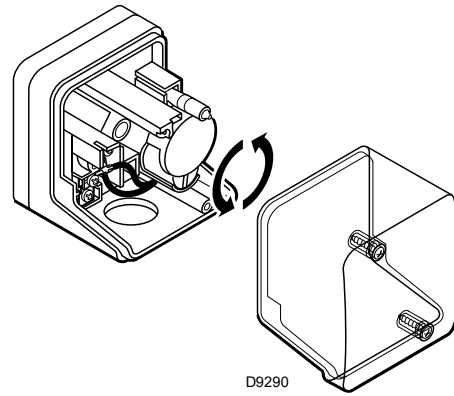

Fig. 40



1 kPa = 10 mbar

WARNING

5.6 Flame signal measurement

Check the flame signal through the parameter 954, as indicated in Fig. 41. The displayed value is expressed in percentage.

For further and specific information, please refer to the specific instruction manual.

The value during the operation must be higher than 24%. If at the burner start-up the value is higher or equal of 18%, the burner locks out due to the extraneous light.

The display (Fig. 41) shows parameter **954**: flashing on the left. On the right, the flame's intensity is displayed as a percentage. Example: **954: 0.0**

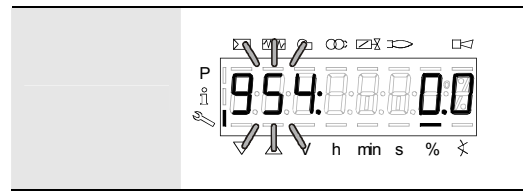

Fig. 41

5.7 Final checks (with the burner working)

<ul style="list-style-type: none"> ➤ Open the control limit operation ➤ Open the high limit operation 	➡	The burner must stop
<ul style="list-style-type: none"> ➤ Rotate the maximum gas pressure switch knob to the minimum end-of-scale position ➤ Rotate the air pressure switch knob to the maximum end of scale position 	➡	The burner must stop in lockout
<ul style="list-style-type: none"> ➤ Switch off the burner and disconnect the voltage ➤ Disconnect the minimum gas pressure switch 	➡	The burner must not start
<ul style="list-style-type: none"> ➤ Cover the flame sensor 	➡	The burner must stop in lockout due to firing failure



Make sure that the mechanical locking systems on the different adjustment devices are fully tightened.

WARNING

6

Maintenance

6.1 Notes on safety for the maintenance

The periodic maintenance is essential for the good operation, safety, yield and duration of the burner.

It allows you to reduce consumption and polluting emissions and to keep the product in a reliable state over time.



The maintenance interventions and the calibration of the burner must only be carried out by qualified, authorised personnel, in accordance with the contents of this manual and in compliance with the standards and regulations of current laws.

Before carrying out any maintenance, cleaning or checking operations:



Disconnect the electrical supply from the burner by means of the main system switch.



Close the fuel interception tap.



Wait for the components in contact with heat sources to cool down completely.

6.2 Maintenance programme

6.2.1 Maintenance frequency



The gas combustion system should be checked at least once a year by a representative of the manufacturer or another specialised technician.

6.2.2 Safety test - with gas ball valve closed

It is fundamental to ensure the correct execution of the electrical connections between the gas solenoid valves and the burner to perform safely the commissioning.

For this purpose, after checking that the connections have been carried out in accordance with the burner's electrical diagrams, an ignition cycle with closed gas ball valve -dry test- must be performed.

- 1 The manual ball gas valve must be closed
- 2 The electrical contacts of the burner limit switch need to be closed
- 3 Ensures closed the contact of the low gas pressure switch
- 4 Make a trial for burner ignition

The start-up cycle must be as follows:

- starting the fan for pre-ventilation
- Performing the gas valve seal control, if provided
- Completion of pre-ventilation
- Arrival of the ignition point
- Power supply of the ignition transformer
- Electrical Supply of solenoid gas valves

Since the manual gas ball valve is closed, the burner will not light up and its flame control will go to a safety lockout condition.

The actual electrical supply of the solenoid gas valves can be verified by inserting a tester. Some valves are equipped with light signals (or close/open position indicator) that turn on at the same time as their power supply.



IF THE ELECTRICAL SUPPLY OF THE GAS VALVES OCCURS AT UNEXPECTED TIMES, DO NOT OPEN MANUAL GAS BALL VALVE, SWITCH OFF POWER LINE; CHECK THE WIRES; CORRECT THE ERRORS AND REPEAT THE COMPLETE TEST.

6.2.3 Checking and cleaning



The operator must use the required equipment during maintenance.

Combustion

The optimum calibration of the burner requires an analysis of the flue gases. Significant differences with respect to the previous measurements indicate the points where more care should be exercised during maintenance.

Adjust the burner if the combustion values found at the beginning of the operation do not comply with the regulations in force or, at any rate, do not produce good combustion.

Use the appropriate card to record the new combustion values; they will be useful for subsequent controls.

Gas leaks

Make sure there are no gas leaks on the conduit between the gas meter and the burner.

Gas filter

Replace the gas filter when it is dirty.

Flame inspection window

Clean the glass of the flame inspection window.

Combustion head

Open the burner and make sure that all the components of the combustion head are:

- undamaged
- not deformed due to high temperature
- free of ambient dirt or dust
- free of rusted materials
- adequately positioned

Make sure that the gas outlet holes for the start-up, on the combustion head distributor, are free of dirt or rust deposits.

In case of doubt, disassemble the inner part 5)(Fig. 43, page 33).

Flame sensor

In order to reach the flame sensor (Fig. 42), proceed as follows:

- extract the sensor 2).
- Clean the glass cover from any dust that may have accumulated.



WARNING

- Be extremely careful while troubleshooting the detector; line voltage is present on some of the terminals when power is on.
- Open the master switch to disconnect power before removing or installing the sensor.

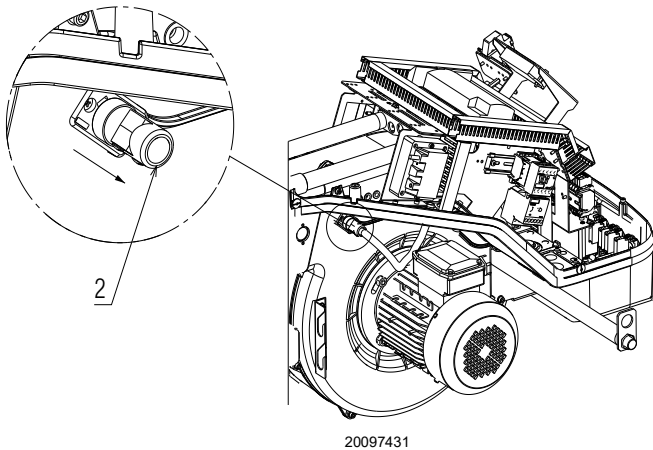

Fig. 42

6.2.4 Safety components

The safety components must be replaced at the end of their life cycle indicated in Tab. J. The specified life cycles do not refer to the warranty terms indicated in the delivery or payment conditions.

Safety component	Life cycle
Flame control	10 years or 250.000 operation cycles
Flame sensor	10 years or 250.000 operation cycles
Gas valves (solenoid)	10 years or 250.000 operation cycles
Pressure switches	10 years or 250.000 operation cycles
Pressure adjuster	15 years
Servomotor (electronic cam) (if present)	10 years or 250.000 operation cycles
Oil valve (solenoid) (if present)	10 years or 250.000 operation cycles
Oil regulator (if present)	10 years or 250.000 operation cycles
Oil pipes / couplings (metallic) (if present)	10 years
Fan impeller	10 years or 500.000 start-ups

Tab. J

6.3 Opening the burner



Disconnect the electrical supply from the burner by means of the main system switch.



Close the fuel interception tap.



Wait for the components in contact with heat sources to cool down completely.

In order to open the burner, proceed as follows:

- loosen the 4 screws 1)(Fig. 43) and remove the cover 2);
- install the 2 extensions 9) on the sliding bars 4) and re-screw the screws 8);
- remove the screws 3) and pull back the burner on the sliding bars 4) of about 4";
- disconnect the electrode lead, then unthread the burner completely from the sliding bars;
- remove the screw 6) and extract the inner part 5) of the head.

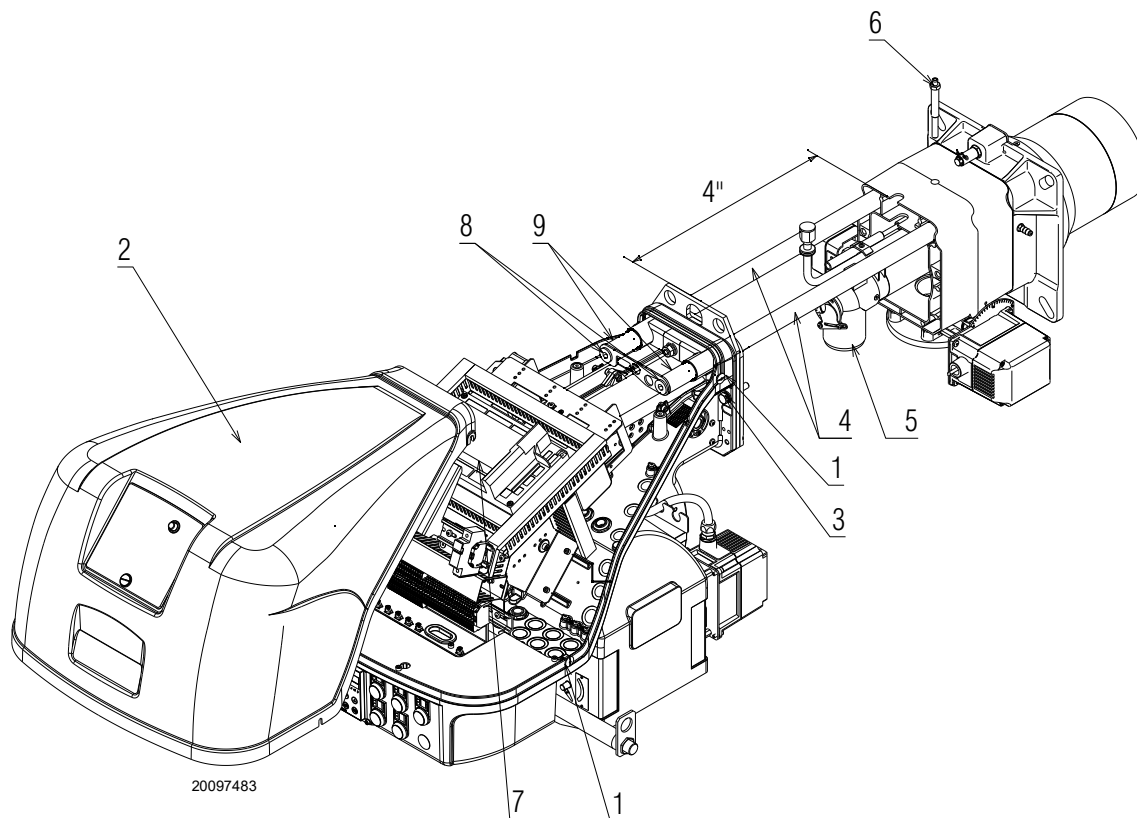

Fig. 43

6.4 Closing the burner

In order to close the burner, re-install all components with reverse procedure:

- remove the 2 extensions 9)(Fig. 43) and re-screw the screws 8) on the sliding bars 4);
- push the burner up to approximately 4" from the pipe coupling;
- reinsert the electrode lead and slide the burner as far as the stop.
- fix the screws 3) to secure the burner to the combustion head;
- fix the 4 screws 1) to install the cover 2).



Connect the electrical supply from the burner.



After carrying out maintenance, cleaning or checking operations, reassemble the hood and all the safety and protection devices of the burner.

A

Appendix - Spare parts

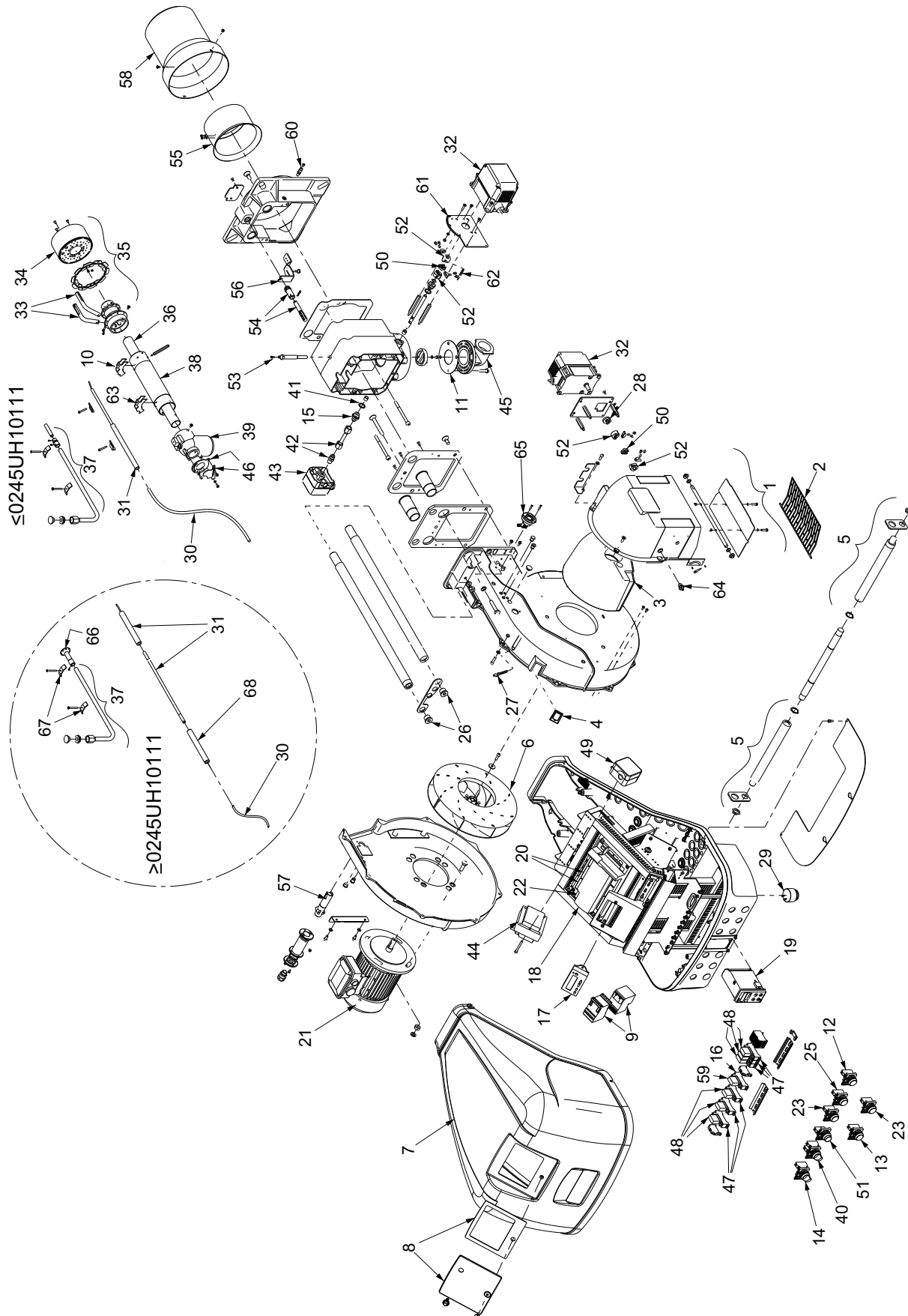

N.	CODE	20189628	20189629	20189631	20189632	20189633	20189634	20189627	20189726	20189794	20189732	20189735	20189795	20189737	DESCRIPTION	BURNER SERIAL NUMBER	*
1	3013929	•	•	•	•	•	•	•	•	•	•	•	•	•	AIR DAMPER ASSEMBLY		
2	3003949	•	•	•	•	•	•	•	•	•	•	•	•	•	PROTECTION		
3	3003952	•	•	•	•	•	•	•	•	•	•	•	•	•	SOUND DAMPING		
4	3003763	•	•	•	•	•	•	•	•	•	•	•	•	•	INSPECTION WINDOW		
5	3013686	•	•	•	•	•	•	•	•	•	•	•	•	•	EXTENSION		
6	3012940	•	•	•	•	•	•	•	•	•	•	•	•	•	FAN		C
6	3012403							•							FAN		C
7	20086561	•	•	•	•	•	•	•	•	•	•	•	•	•	COVER		B
8	20075921	•	•	•	•	•	•	•	•	•	•	•	•	•	VIEWING PORT		
9	20115409	•	•	•	•	•	•	•	•	•	•	•	•	•	OVERLOAD		C
9	20174709							•							OVERLOAD		C
10	3013087	•	•	•	•	•	•	•	•	•	•	•	•	•	SUPPORT		A
11	3005482	•	•	•	•	•	•	•	•	•	•	•	•	•	SEAL		B
12	20027018	•	•	•	•	•	•	•	•	•	•	•	•	•	RED SIGNAL LIGHT		A
13	20027020	•	•	•	•	•	•	•	•	•	•	•	•	•	YELLOW SIGNAL LIGHT		A
14	20027021	•	•	•	•	•	•	•	•	•	•	•	•	•	SELECTOR SWITCH		
15	3003220	•	•	•	•	•	•	•	•	•	•	•	•	•	CONNECTOR		C
16	3020071	•	•	•	•	•	•	•	•	•	•	•	•	•	BASE		
17	3013926	•	•	•	•	•	•	•	•	•	•	•	•	•	DISPLAY		
18	20010968	•	•	•	•	•	•	•	•	•	•	•	•	•	ELECTRONIC CAM		C
19	20096592	•	•	•	•	•	•	•	•	•	•	•	•	•	POWER REGULATOR		C
20	3013940	•	•	•	•	•	•	•	•	•	•	•	•	•	CONNECTORS ASSEMBLY		B
21	3012943	•	•		•	•			•	•	•	•			MOTOR		C
21	20062892			•		•							•		MOTOR		C
21	20094157							•							MOTOR		C
22	3014106	•	•	•	•	•	•	•	•	•	•	•	•	•	FUSE		A
23	20036017	•	•	•	•	•	•	•	•	•	•	•	•	•	GREEN SIGNAL LIGHT		A
25	20027014	•	•	•	•	•	•	•	•	•	•	•	•	•	WHITE SIGNAL LIGHT		A
26	3013681	•	•	•	•	•	•	•	•	•	•	•	•	•	SCREW		
27	3003891	•	•	•	•	•	•	•	•	•	•	•	•	•	CONNECTOR		C
28	3014079	•	•	•	•	•	•	•	•	•	•	•	•	•	SPACER		
29	20031413	•	•	•	•	•	•	•	•	•	•	•	•	•	HORN		
30	3012393	•	•	•	•	•	•	•	•	•	•	•	•	•	CONNECTION		A
31	3013081	•	•	•	•	•	•	•	•	•	•	•	•	•	ELECTRODE	≤ 0245UH10111	A
31	20038216	•	•	•	•	•	•	•	•	•	•	•	•	•	ELECTRODE	≥ 0245UH10111	A
32	20008601	•	•	•	•	•	•	•	•	•	•	•	•	•	SERVOMOTOR		B
33	3012924	•	•	•	•	•	•	•							TUBE		C
33	3012925								•	•	•	•	•		TUBE		C
34	3013082	•	•	•	•	•	•	•							AIR DIFFUSER		
34	3013083								•	•	•	•	•		AIR DIFFUSER		
35	3013084	•	•	•	•	•	•	•							DISTRIBUTOR		
35	3013085								•	•	•	•	•		DISTRIBUTOR		
36	3012035	•	•	•	•	•	•	•	•	•	•	•	•	•	TUBE		C
37	3012974	•	•	•	•	•	•	•	•	•	•	•	•	•	TUBE		C
38	3013088	•	•	•	•	•	•	•	•	•	•	•	•	•	TUBE		C
39	3012412	•	•	•	•	•	•	•	•	•	•	•	•	•	ELBOW		
40	20027422	•	•	•	•	•	•	•	•	•	•	•	•	•	SELECTOR SWITCH		
41	3007088	•	•	•	•	•	•	•	•	•	•	•	•	•	SEAL		B
42	3013055	•	•	•	•	•	•	•	•	•	•	•	•	•	TUBE		C
43	3012969	•	•	•	•	•	•	•	•	•	•	•	•	•	GAS PRESSURE SWITCH		A
44	3012956	•	•	•	•	•	•	•	•	•	•	•	•	•	TRANSFORMER		B
45	3012971	•	•	•	•	•	•	•	•	•	•	•	•	•	FLANGE		C
46	3012014	•	•	•	•	•	•	•	•	•	•	•	•	•	RING NUT		
47	3012841	•	•	•	•	•	•	•	•	•	•	•	•	•	BASE		
48	20010969	•	•	•	•	•	•	•	•	•	•	•	•	•	RELAY		C
49	3012948	•	•	•	•	•	•	•	•	•	•	•	•	•	AIR PRESSURE SWITCH		A

N.	CODE	20189628	20189629	20189631	20189632	20189633	20189634	20189627	20189726	20189794	20189732	20189735	20189795	20189737	DESCRIPTION	BURNER SERIAL NUMBER	*
50	3013938	•	•	•	•	•	•	•	•	•	•	•	•	•	DISC		A
51	20010962	•	•	•	•	•	•	•	•	•	•	•	•	•	BUTTON		
52	3013937	•	•	•	•	•	•	•	•	•	•	•	•	•	HUB		
53	3012049	•	•	•	•	•	•	•	•	•	•	•	•	•	SCREW		
54	3012639	•	•	•	•	•	•	•	•	•	•	•	•	•	ADJUSTMENT ASSEMBLY		
55	20030203	•	•	•	•	•	•	•	•	•	•	•	•	•	SHUTTER		C
55	20030202	•	•	•	•	•	•	•	•	•	•	•	•	•	SHUTTER		C
56	20030204	•	•	•	•	•	•	•	•	•	•	•	•	•	SQUARE		
57	20186817	•	•	•	•	•	•	•	•	•	•	•	•	•	FLAME SENSOR		A
58	20030206	•	•	•	•	•	•	•	•	•	•	•	•	•	FLAME FUNNEL		B
59	3020068	•	•	•	•	•	•	•	•	•	•	•	•	•	RELAY		C
60	3003322	•	•	•	•	•	•	•	•	•	•	•	•	•	CONNECTOR		C
61	3014081	•	•	•	•	•	•	•	•	•	•	•	•	•	BRACKET		
62	3013939	•	•	•	•	•	•	•	•	•	•	•	•	•	INDEX		
63	3013086	•	•	•	•	•	•	•	•	•	•	•	•	•	SUPPORT		A
64	3012088	•	•	•	•	•	•	•	•	•	•	•	•	•	CONNECTOR		C
65	3013933	•	•	•	•	•	•	•	•	•	•	•	•	•	INSPECTION WINDOW		
66	20129663	•	•	•	•	•	•	•	•	•	•	•	•	•	GAS DIFFUSER	≥ 0245UH10111	
67	3013001	•	•	•	•	•	•	•	•	•	•	•	•	•	U BOLT	≥ 0245UH10111	
68	3012258	•	•	•	•	•	•	•	•	•	•	•	•	•	INSULATOR	≥ 0245UH10111	A

*

ADVISED PARTS

- A = Spare parts for minimum fittings
- A+B = Spare parts for basic safety fittings
- A+B+C = Spare parts for extended safety fittings

B**Appendix - Accessories**

- **Tubes kit**

Burner	Code
RS 68/E-EV LN	3010247
RS 120/E-EV LN	3010248

- **Gas train according to UL Standards**



The installer is responsible for the supply and installation of any required safety device(s) not indicated in this manual.

C**Appendix - Burner start up report**

Model number:	Serial number:
Project name:	Start-up date:
Installing contractor:	Phone number:

Model number:	Serial number:
Project name:	Start-up date:
Installing contractor:	Phone number:

GAS OPERATION

Gas Supply Pressure:	CO ₂ : Low Fire	High Fire
Main Power Supply:	O ₂ : Low Fire	High Fire
Control Power Supply:	CO: Low Fire	High Fire
Burner Firing Rate:	NO _x : Low Fire	High Fire
Manifold Pressure:	Net Stack Temp - Low Fire:	High Fire
Pilot Flame Signal:	Comb. Efficiency - Low Fire:	High Fire
Low Fire Flame Signal:	Overfire Draft:	
High Fire Flame Signal:		

CONTROL SETTINGS

Operating Setpoint:	Low Oil Pressure:
High Limit Setpoint:	High Oil Pressure:
Low Gas Pressure:	Flame Safeguard Model Number:
High Gas Pressure:	Modulating Signal Type:

NOTES

RIELLO

RIELLO S.p.A.
I-37045 Legnago (VR)
Tel.: +39.0442.630111
[http:// www.riello.com](http://www.riello.com)

RIELLO

35 Pond Park Road
Hingham, Massachusetts,
U.S.A. 02043

RIELLO BURNERS NORTH AMERICA
<http://www.riello.ca>

1-800-4-RIELLO

2165 Meadowpine Blvd
Mississauga, Ontario
Canada L5N 6H6