



## Light oil burner

Single stage operation



# B20

CODE	MODEL	TYPE
20194362	RIELLO 40 F20 B20 WITH HYDRAULIC JACK	275T



**Original instructions**

<b>1</b>	<b>Information and general instructions</b>	<b>3</b>
1.1	Information about the instruction manual	3
1.1.1	Introduction	3
1.1.2	General dangers	3
1.1.3	Other symbols	3
1.1.4	Delivery of the system and the instruction manual	4
1.2	Guarantee and responsibility	4
1.3	Guidance for the use of biofuel blends up to 20%	5
1.3.1	Information and general instructions	6
1.3.2	Product Disclaimer Statement	6
<b>2</b>	<b>Safety and prevention</b>	<b>7</b>
2.1	Introduction	7
2.2	Personnel training	7
2.3	Serial number identification	8
<b>3</b>	<b>Technical description of the burner</b>	<b>9</b>
3.1	Burner models designations	9
3.2	Technical data	9
3.3	Electrical data	9
3.4	Burner dimensions	10
3.5	Package contents list	10
3.6	Firing rates	11
3.7	Burner description	12
3.8	Flame control	13
<b>4</b>	<b>Installation</b>	<b>14</b>
4.1	Notes on safety for the installation	14
4.2	Installation precautions	14
4.3	Preliminary checks	15
4.4	Installer/Service notes for the use of Gas oil with Bio blends up to 20%	15
4.5	Operating position	15
4.6	Initial set-up	16
4.7	Assembly of air tube to burner chassis	16
4.8	Mounting the burner to the boiler	16
4.8.1	Method 1 – Universal mounting flange	17
4.8.2	Method 2 – Semi-flange collar	17
4.8.3	Method 3 – Pedestal mount	17
4.9	Installation/removal of drawer assembly	18
4.10	Electrode setting	18
4.11	Nozzle	19
4.11.1	Nozzle placement	19
4.12	Turbulator setting	19
<b>5</b>	<b>Hydraulic systems</b>	<b>20</b>
5.1	Oil line connections	20
5.2	Pump	20
5.2.1	Two line (lift system)	21
5.2.2	Pump purge	22
5.2.3	Two line (gravity or lift system)	22
5.3	Air shutter setting	23
5.3.1	Low fire setting	23
5.3.2	Main flame setting	23

<b>6</b>	<b>Electrical system</b>	<b>24</b>
6.1	Electrical wiring	24
6.1.1	Flame control	25
6.1.2	Application field wiring	26
6.2	Burner start-up cycle	26
<b>7</b>	<b>Start-up, calibration and operation of the burner</b>	<b>27</b>
7.1	Notes on safety for the first start-up	27
7.2	Burner set-up chart	27
7.3	Ducted combustion air intake applications	28
<b>8</b>	<b>Maintenance</b>	<b>29</b>
8.1	Notes on safety for the maintenance	29
8.2	Maintenance programme	29
8.2.1	Maintenance frequency	29
8.2.2	Checking and cleaning	29
8.2.3	Safety components	30
<b>9</b>	<b>Faults / Solutions</b>	<b>31</b>
<b>10</b>	<b>Appendix - Accessories</b>	<b>32</b>
<b>11</b>	<b>Burner start-up report</b>	<b>33</b>
<b>12</b>	<b>Spare parts</b>	<b>34</b>
12.1	Exploded spare parts	34
12.2	Spare parts list	35

**1 Information and general instructions**

**1.1 Information about the instruction manual**

**1.1.1 Introduction**

The instruction manual supplied with the burner:

- is an integral and essential part of the product and must not be separated from it; it must therefore be kept carefully for any necessary consultation and must accompany the burner even if it is transferred to another owner or user, or to another system. If the manual is lost or damaged, another copy must be requested from the Technical Assistance Service of the area;
- is designed for use by qualified personnel;
- offers important indications and instructions relating to the installation safety, start-up, use and maintenance of the burner.

**Symbols used in the manual**

In some parts of the manual you will see triangular DANGER signs. Pay great attention to these, as they indicate a situation of potential danger.

**1.1.2 General dangers**

The **dangers** can be of **3 levels**, as indicated below.



**DANGER**

Maximum danger level!  
This symbol indicates operations which, if not carried out correctly, cause serious injury, death or long-term health risks.



**WARNING**

This symbol indicates operations which, if not carried out correctly, may cause serious injury, death or long-term health risks.



**CAUTION**

This symbol indicates operations which, if not carried out correctly, may cause damage to the machine and/or injury to people.

**1.1.3 Other symbols**



**DANGER**

**DANGER: LIVE COMPONENTS**  
This symbol indicates operations which, if not carried out correctly, lead to electric shocks with lethal consequences.



**DANGER: FLAMMABLE MATERIAL**  
This symbol indicates the presence of flammable materials.



**DANGER: BURNING**  
This symbol indicates the risks of burns due to high temperatures.



**DANGER: CRUSHING OF LIMBS**  
This symbol indicates the presence of moving parts: danger of crushing of limbs.



**WARNING: MOVING PARTS**  
This symbol indicates that you must keep limbs away from moving mechanical parts; danger of crushing.



**DANGER: EXPLOSION**  
This symbol signals places where an explosive atmosphere may be present. An explosive atmosphere is defined as a mixture - under atmospheric conditions - of air and flammable substances in the form of gases, vapours, mist or dust in which, after ignition has occurred, combustion spreads to the entire unburned mixture.



**PERSONAL PROTECTION EQUIPMENT**  
These symbols indicate the equipment that must be worn and kept by the operator for protection against threats against safety and/or health while at work.



**OBLIGATION TO ASSEMBLE THE HOOD AND ALL THE SAFETY AND PROTECTION DEVICES**  
This symbol signals the obligation to reassemble the hood and all the safety and protection devices of the burner after any maintenance, cleaning or checking operations.



**ENVIRONMENTAL PROTECTION**  
This symbol gives indications for the use of the machine with respect for the environment.



**IMPORTANT INFORMATION**  
This symbol indicates important information that you must bear in mind.

- This symbol indicates a list.

**Abbreviations used**

Ch.	Chapter
Fig.	Figure
Page	Page
Sec.	Section
Tab.	Table

### 1.1.4 Delivery of the system and the instruction manual

When the system is delivered, it is important that:

- the instruction manual is delivered to the user by the system manufacturer, with the recommendation to keep it in the room where the heat generator is to be installed.
- The instruction manual shows:
  - the serial number of the burner;

.....

- the address and telephone number of the nearest Assistance Centre.

.....  
 .....  
 .....

- The system supplier must carefully inform the user about:
  - the use of the system;
  - any further tests that may be required before activating the system;
  - maintenance, and the need to have the system checked at least once a year by a representative of the manufacturer or another specialised technician.
 To ensure a periodic check, the manufacturer recommends the drawing up of a Maintenance Contract.

### 1.2 Guarantee and responsibility

The Manufacturer guarantees its new products from the date of installation, in accordance with the regulations in force and/or the sales contract. At the moment of the first start-up, check that the burner is integral and complete.



**WARNING**

Failure to observe the information given in this manual, operating negligence, incorrect installation and carrying out of non authorised modifications will result in the annulment by the manufacturer of the guarantee that it supplies with the burner.

In particular, the rights to the guarantee and the responsibility will no longer be valid, in the event of damage to things or injury to people, if such damage/injury was due to any of the following causes:

- incorrect installation, start-up, use and maintenance of the burner;
- improper, incorrect or unreasonable use of the burner;
- intervention of unqualified personnel;
- carrying out of unauthorised modifications on the equipment;
- use of the burner with safety devices that are faulty, incorrectly applied and/or not working;
- installation of untested supplementary components on the burner;
- powering of the burner with unsuitable fuels;
- faults in the fuel supply system;
- continuation of use of the burner when a fault has occurred;
- repairs and/or overhauls incorrectly carried out;
- modification of the combustion chamber with inserts that prevent the regular development of the structurally established flame;
- insufficient and inappropriate surveillance and care of those burner components most likely to be subject to wear and tear;
- use of non-original components, including spare parts, kits, accessories and optional;
- force majeure.

**The manufacturer furthermore declines any and every responsibility for the failure to observe the contents of this manual.**

The manufacturer's warranty is subject to correct burner, appliance and application matching, and set up in line with Manufacturer's instructions and guidelines. All components within the hydraulic circuit suitable for biofuel use and supplied by the manufacturer will be identified as bio-compatible. No warranty is given in relation to the use of components which are not so identified with biofuel blends. If in any doubt please contact the manufacturer for further advice.

If any burners are used with fuel with a bio content > 20% then the components within the hydraulic circuit may be affected and are not covered under warranty. The hydraulic circuit consists of:

- pump
- hydraulic ram (where applicable)
- valve block
- high fire delay valve (where applicable)
- nozzle holder
- rigid piping

- 1 Irrespective of any warranty given by the manufacturer in relation to normal use and manufacturing defects, when fuels not meeting the relevant standards are used, or where fuel storage issues have not been addressed correctly, or the equipment used is not compatible, if failures occur which are directly or indirectly attributed to such issues and/or to the non-observance of this guidance, then no warranty or liability is implied or accepted by the manufacturer.
- 2 The manufacturer has carefully chosen the specification of the bio-compatible components including the flexible oil lines to protect the pump, safety valve and nozzle. The manufacturer warranty is dependent upon the use of genuine components including the oil lines, being used.
- 3 The manufacturer warranty does not cover defects arising from incorrect commissioning or servicing by non manufacturer employed service engineers, and any issues impacting the burner arising from external site related issues.

### 1.3 Guidance for the use of biofuel blends up to 20%

#### Introduction

With increasing focus on renewable and sustainable energy requirements, biofuel usage is set to increase. The manufacturer is committed to promoting energy conservation and the use of renewable energy from sustainable resources including liquid biofuels, however there are some technical aspects that must be considered at the planning stage of using such fuels to reduce the potential for equipment failure or the risks of fuel leakage. Liquid biofuel is a generic description used for oil that can come from numerous feed stocks including recycled cooking oils. These types of oils have to be considered and treated differently from standard mineral or fossil fuels, as they are generally more acidic, hygroscopic and less stable. Due to this, a holistic approach is needed for the specification of the liquid biofuel, the storage of the fuel, its oil supply line and ancillary equipment, and very importantly the oil filtration and the burner itself. The specification for FAME (Fatty Acids Methyl Ester) liquid biofuel is critical to reliable equipment operation. It is a minimum requirement that the fuel blend (up to 20% bio) is obtained with light oil in accordance with the relevant ASTM D396-21 standards. Grades B6-B20 S5000, B6-B20 S500, and B6-B20 S15 are middle distillate fuel/biodiesel blends for use in domestic and small industrial burners.

When choosing your oil products where you know biofuels will be in use, please make sure that a bio-compatible burner and/or components have been supplied. If an existing burner is to be used with a liquid biofuel then a kit may be required to make it compatible and the guidance notes enclosed concerning oil storage and filtration must be adhered to. The end user is responsible for the thorough verification of the potential risks associated with the introduction of a biofuel blend and the suitability of the appliances and installation applicable. Irrespective of any warranty given by the manufacturer in relation to normal use and manufacturing defects, when fuels not meeting the relevant standards are used, or where fuel storage issues have not been addressed correctly, or the equipment used is not compatible, if failures occur which are directly or indirectly attributed to such issues and/or to the non-observance of this guidance, then no warranty or liability is implied or accepted by the manufacturer.

### 1.3.1 Information and general instructions

To ensure consistency, the supplier of the fuel must be able to demonstrate compliance with a recognised Quality Control and management system to ensure high standards are maintained within the storage, blending and delivery processes.

The installation oil storage tank and its ancillaries must also be prepared **BEFORE** liquid biofuel is introduced.

Checks and preparation should include:

- For new installations, make sure that all materials and seals in the oil storage and supply line to the burner are compatible with biofuels. For all installations, there must be a good quality bio-compatible oil filter at the tank and then a secondary filter of 60 Microns protecting the burner from contamination.
- If an existing oil storage tank is to be used then in addition to the materials checks as detailed above, it will be essential that the tank is first inspected for condition and checked for water or other contamination. The manufacturer strongly recommends that the tank is cleaned and oil filters replaced prior to biofuel delivery. If this is not completed then due to the hydroscopic nature of biofuel, it will effectively clean the tank, absorb water present which in turn will result in equipment failure that is not covered by the manufacturer's warranty.
- Depending on the capacity of the oil storage tank and oil usage, fuels may remain static within the tank for some considerable time and so the manufacturer recommends that the oil distributor is consulted regarding the use of additional biocides within the fuel to prevent microbial growth from occurring within the tank. The manufacturer suggests that fuel suppliers and or service companies be contacted for guidance on fuel filtration. Special attention should be applied to dual fuel applications where oil may be stored for long periods of time.
- The burner must be set according to the appliance application and commissioned checking that all combustion parameters are as recommended in the appliance technical manual.
- The manufacturer recommends that the in line and burner oil pump filters are inspected and if required replaced at least every 4 months during burner use, before the burner start-up following a long period of discontinue operation and even more frequently where contamination has occurred. Particular attention is needed when inspecting and checking for fuel leakages from seals, gaskets and hoses.

### 1.3.2 Product Disclaimer Statement

**CAREFULLY READ THE FOLLOWING DISCLAIMER. YOU ACCEPT AND AGREE TO BE BOUND BY THIS DISCLAIMER BY PURCHASING BIO-COMPATIBLE BURNERS AND/OR COMPONENTS.**

Although the information and recommendations (hereinafter "Information") in this guidance is presented in good faith, believed to be correct and has been carefully checked, the manufacturer (and its subsidiaries) makes no representations or warranties as to the completeness or accuracy of the Information. Information is supplied upon the condition that the persons receiving same will make their own determination as to its suitability for their purposes prior to use. In no event will the manufacturer (and its subsidiaries) be responsible for damages of any nature whatsoever resulting from the use of or reliance upon Information. Other than set forth herein, the manufacturer (and its subsidiaries) makes no additional warranties with respect to the bio-compatible burner, either express or implied, including that of marketability or fitness for a particular purpose or use.

In no event shall the manufacturer (and its subsidiaries) be liable for any indirect, incidental, special or consequential damages including, without limitation, loss of profits, damages for loss of business profits, business interruption, loss of business information, loss of equipment, or other pecuniary loss or compensation for services whether or not it is advised of the possibility of such damages.

With the exception of injuries to persons, the manufacturer's liability is limited to the customer's right to return defective/non-conforming products as provided by the relevant product warranty.

## 2

## Safety and prevention

## 2.1 Introduction

The burners have been designed and built in compliance with current regulations and directives, applying the known technical rules of safety and envisaging all the potential danger situations.

It is necessary, however, to bear in mind that the imprudent and clumsy use of the equipment may lead to situations of death risk for the user or third parties, as well as the damaging of the burner or other items. Inattention, thoughtlessness and excessive confidence often cause accidents; the same applies to tiredness and sleepiness.

It is a good idea to remember the following:

- The burner must only be used as expressly described. Any other use should be considered improper and therefore dangerous.

In particular:

it can be applied to boilers operating with water, steam, diathermic oil, and to other uses expressly named by the manufacturer;

the type and pressure of the fuel, the voltage and frequency of the electrical power supply, the minimum and maximum deliveries for which the burner has been regulated, the pressurisation of the combustion chamber, the dimensions of the combustion chamber and the room temperature must all be within the values indicated in the instruction manual.

- Modification of the burner to alter its performance and destinations is not allowed.
- The burner must be used in exemplary technical safety conditions. Any disturbances that could compromise safety must be quickly eliminated.
- Opening or tampering with the burner components is not allowed, apart from the parts requiring maintenance.
- Only those parts envisaged by the manufacturer can be replaced.



The manufacturer guarantees safety and proper functioning only if all burner components are intact and positioned correctly.

## 2.2 Personnel training

The user is the person, body or company that has acquired the machine and intends to use it for the specific purpose. He is responsible for the machine and for the training of the people working around it.

The user:

- undertakes to entrust the machine exclusively to suitably trained and qualified personnel;
- undertakes to inform his personnel in a suitable way about the application and observance of the safety instructions. With that aim, he undertakes to ensure that everyone knows the use and safety instructions for his own duties;
- Personnel must observe all the danger and caution indications shown on the machine.
- Personnel must not carry out, on their own initiative, operations or interventions that are not within their province.
- Personnel must inform their superiors of every problem or dangerous situation that may arise.
- The assembly of parts of other makes, or any modifications, can alter the characteristics of the machine and hence compromise operating safety. The manufacturer therefore declines any and every responsibility for any damage that may be caused by the use of non-original parts.

In addition:



- the user must take all the measures necessary to prevent unauthorised people gaining access to the machine;
- the user must inform the manufacturer if faults or malfunctioning of the accident prevention systems are noticed, along with any presumed danger situation.
- Personnel must always use the personal protective equipment envisaged by legislation and follow the indications given in this manual.

### 2.3 Serial number identification

The RIELLO 11 character serial number, example, **CA01PA00001**, is identified as follows:

- CA** = FACTORY CODE
- 01** = WEEK OF MANUFACTURE
- P** = YEAR OF MANUFACTURE (CREATED FOLLOWING TRANSCODING TABLE)
- A** = PRODUCTION LINE
- 00001** = INCREMENT OF 1 FOR EACH BURNER PRODUCED

M	2017
N	2018
O	2019
P	2020
Q	2021
R	2022
S	2023
T	2024
U	2025
V	2026
W	2027
X	2028
Y	2029
Z	2030

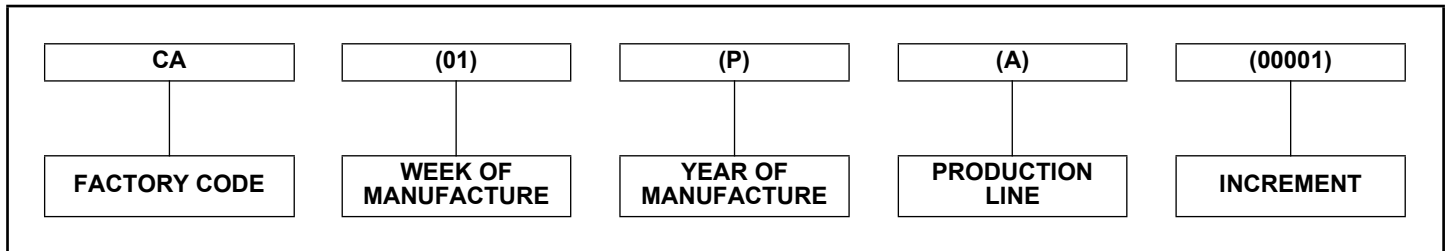

**3 Technical description of the burner**

**3.1 Burner models designations**

Model	Code	Voltage	Flame safeguard
RIELLO 40 F20 B20 WITH HYDRAULIC JACK	20194362	120/1/60	Burner mounted

**Tab. A**

**3.2 Technical data**

Model	RIELLO 40 F20 B20	
Firing rate - Effective Output	US GPH	3.50 to 6.40
	BTU/h	490,000 to 896,000
Fuel	- No. 2 Fuel Oil	
	- B6-B20 Light oil/ Biodiesel blends	
Operation	ON - OFF	
Standard applications	Boilers: water, steam, thermal oil	
Ambient temperature	°F	32 - 104 (0 - 40 °C)
Combustion air temperature	°F max	140 (60 °C)
Pump	PSI	100 to 200
Burner weight (complete with packaging)	lbs	30

**Tab. B**

(1) Reference conditions: Ambient temperature 68 °F (20 °C) - Barometric pressure 394 "WC - Altitude 329 ft a.s.l.

**3.3 Electrical data**

Model	RIELLO 40 F20 B20	
Voltage (single phase)	120V 60Hz (+ 10% - 15%)	
Absorbed electrical power	Watts	465
Primary control	Type	RIELLO 530 SE/C
Electrical protection level	NEMA type 2	

**Tab. C**

### 3.4 Burner dimensions

The maximum dimensions of the burners and the mounting flange are given in Fig. 1.

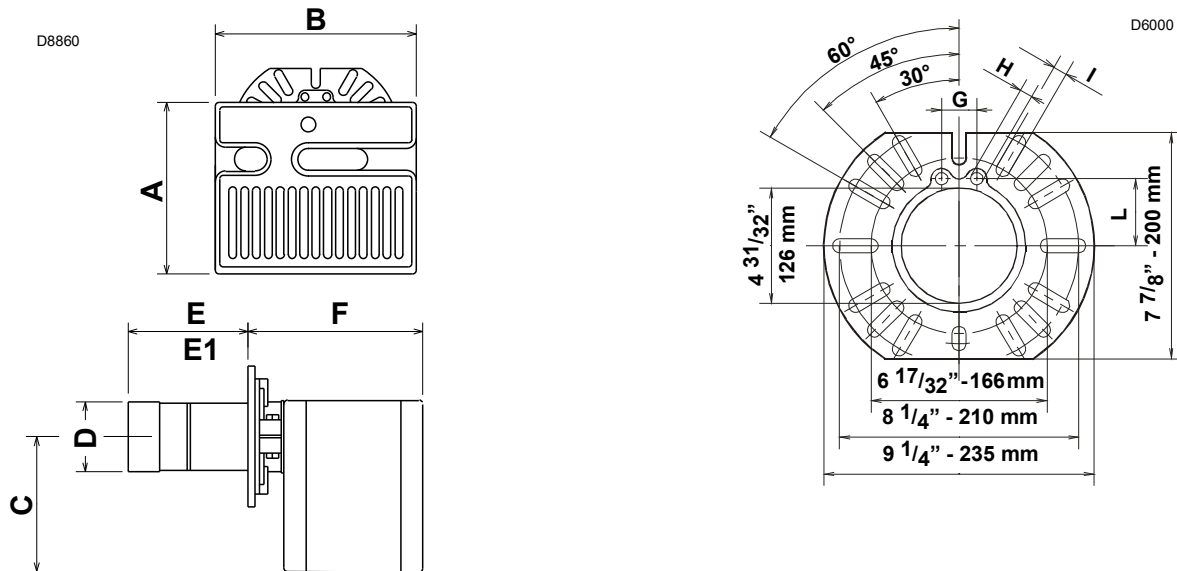

Fig. 1

Model F20	A	B	C	D	E - E1	F	G	H	I	L
Inches	11 3/4	13 25/32	9 1/16	4 11/16	5 - 10	11 27/32	1 1/2	1/4	7/16	2 7/8
mm	298	350	230	119	127 - 254	301	38	6	11	73

Tab. D

E1: 10-inch long (254 mm) tubes are also available.

### 3.5 Package contents list

Your RIELLO 40 burner should include the following parts. Please check to make sure all parts are present before beginning the installation.

Description	Quantity
Burner chassis with cover	3726512 1
Universal mounting flange + mounting gasket	2567395 1
Parts bag	2566283 1
Parts bag	2567338 1
By-pass plug	2902453 1
Installation manual	1
<b>Separate carton</b> - OEM burners shipped with combustion head mounted	
Air Tube/Drawer Assembly	1

Tab. E

Description	Quantity
<b>Parts bag 2566283</b>	
Female 1/4" NPT adapter	1
Male 3/8" NPT adapter	1
Oil pump connector (supply)	1
Oil pump connector (return)	1
Mounting flange bolts (short)	2
Nuts	2
Chrome nuts	2
<b>Parts bag 2567338</b>	
Semi-flange bolts (long)	2
Semi-flanges	2
Cover screws	2
Nuts	2

Tab. F

**3.6 Firing rates**

The burner firing rate is indicated in Fig. 2.



The firing rate area values have been obtained considering an ambient temperature of 68 °F, and an atmospheric pressure of 394" WC and with the combustion head adjusted as shown on page 27.

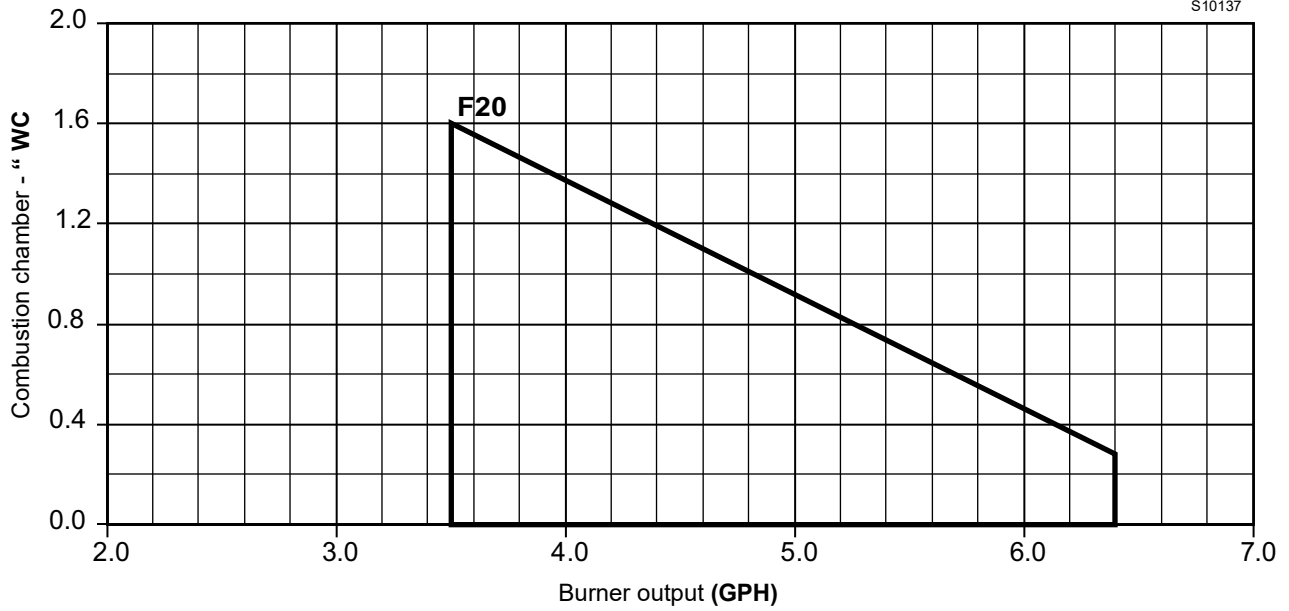

**Fig. 2**

### 3.7 Burner description

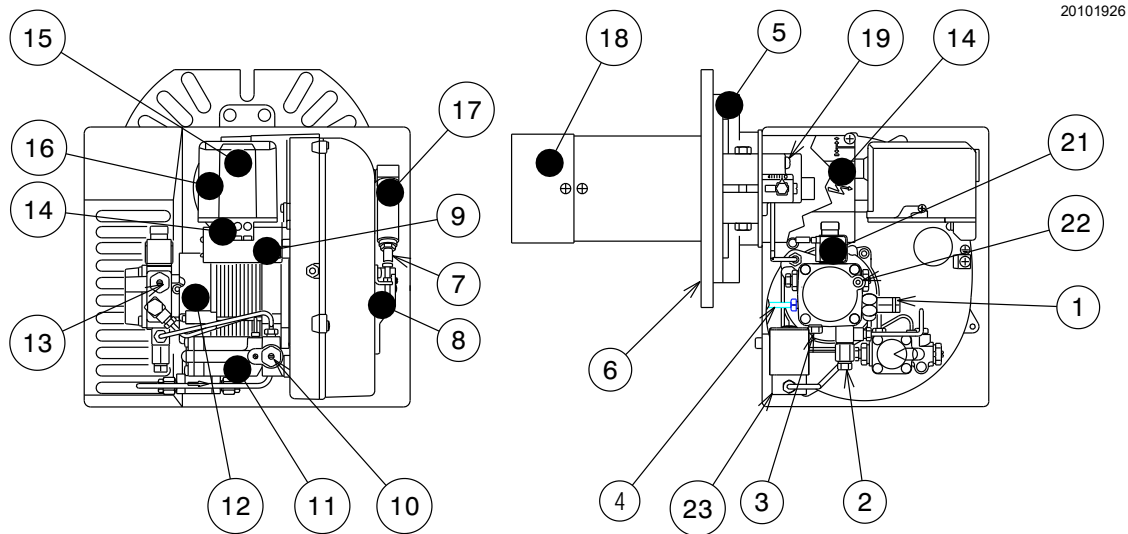

Fig. 3

- |  |   |
|--|---|
| 1 Pressure gauge group and bleeder adjusting screw | 13 Pump pressure regulator adjustment screw |
| 2 Return fuel line port                            | 14 Primary control sub-base                 |
| 3 Inlet fuel line port                             | 15 Lockout indicator lamp and reset button  |
| 4 Capillary tube                                   | 16 Primary control                          |
| 5 Adjustable collar                                | 17 Hydraulic jack                           |
| 6 Mounting flange with gasket                      | 18 End cone                                 |
| 7 Air adjustment fixing screws                     | 19 Turbulator adjustment screw              |
| 8 Hydraulic air shutter                            | 20 Air tube cover                           |
| 9 Capacitor  | 21 Coil                                     |
| 10 Fuel pressure adjustment screw low fire         | 22 Vacuum gauge connection port             |
| 11 Hydraulic delay valve low fire start            | 23 Solenoid valve                           |
| 12 Motor   |   |



The maximum recommended tightening torque for bleeder adjusting screw 1) is 2 Nm.

**3.8 Flame control**

The flame control is a control and supervision system for forced draught burners, for intermittent operation (at least one controlled shut-down every 24 hours).

**Important notes**



To avoid accidents, material or environmental damage, observe the following instructions!

The flame control is a safety device! Avoid opening or modifying it, or forcing its operation. The Manufacturer cannot assume any responsibility for damage resulting from unauthorised work!

- All interventions (assembly and installation operations, assistance, etc.) must be carried out by qualified personnel.
- Before modifying the wiring in the flame control connection area, fully disconnect the system from the power supply (omnipolar separation).
- Protection against electrocution from the flame control and all connected electric components is obtained with the correct assembly.
- Before any intervention (assembly and installation operations, assistance, etc.), ensure the wiring is in order and that the parameters are correctly set, then make the safety checks.
- Falls and collisions can negatively affect the safety functions. In this case, the flame control must not be operated, even if it displays no evident damage.

For safety and reliability, comply with the following instructions:

- avoid conditions that can favour the development of condensate and humidity. Otherwise, before switching on again, make sure the flame control is perfectly dry.
- Static charges must be avoided since they can damage the flame control's electronic components when touched.

**Installation notes**

- Check the electrical wiring inside the boiler complies with the national and local safety regulations.
- Install switches, fuses, earth connection etc. in compliance with local regulations.
- Do not confuse the powered conductors with the neutral ones.
- Ensure that spliced wires cannot get into contact with neighbouring terminals. Use adequate ferrules.
- Arrange the H.V. ignition cables separately, as far as possible from the flame control and the other cables.
- When wiring the unit, make sure the 120 Vac mains voltage cables are run strictly separate from extra low-voltage cables, to avoid the risk of electrocution.

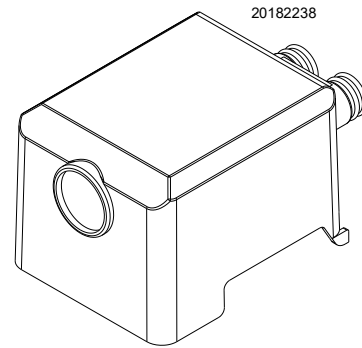

**Fig. 4**

**NOTE:**

**The burners have been approved for intermittent operation. This means that they must stop once every twenty four hours to permit the flame control to check its efficiency at start-up. The boiler thermostat of heat request normally ensures the stopping of the burner. If this is not the case, it is necessary to apply a timer switch in series to the thermostat of heat request that turns off the burner at least once every 24 hours.**

**Technical data**

Mains voltage	120 Vac -15 %/+10 %
Mains frequency	50/60 Hz ±5 %
Built-in fuse	10A 250 V
Energy consumption during the operation	75 VA
Energy consumption	1.5 VA
Protection level	NEMA type 2

**Tab. G**

### 4.1 Notes on safety for the installation

After carefully cleaning all around the area where the burner will be installed, and arranging the correct lighting of the environment, proceed with the installation operations.



All the installation, maintenance and disassembly operations must be carried out with the electricity supply disconnected.



The installation of the burner must be carried out by qualified personnel, as indicated in this manual and in compliance with the standards and regulations of the laws in force.

### 4.2 Installation precautions

#### AIR FOR COMBUSTION

Do not install burner in room with insufficient air for combustion. Be sure there is an adequate air supply for combustion if the boiler/furnace room is enclosed. It may be necessary to create a window to permit sufficient air to enter the boiler/furnace room. The installer must follow local ordinances in this regard.

**CANADA** It is suggested that the installer follow CSA standard B139.

**USA** It is suggested that the installer follow NFPA manual #31.

#### CHIMNEY

Be sure chimney is sufficient to handle the exhaust gases. It is recommended that only the burner be connected to the chimney. Be sure that it is clean and clear of obstructions.

#### OIL FILTER

An external oil filter is **REQUIRED**, even though there is an internal strainer in the pump. The filter should be replaced at least once a year, and the filter container should be thoroughly cleaned prior installing a new filter cartridge.

#### DRAFT

Follow the instructions furnished with the heating appliance. The pressure in the combustion area should be kept as close to zero as possible. The burner will operate with a slight draft or pressure in the chamber.

#### ELECTRICAL CONNECTIONS

**CANADA** All electrical connections should be done in accordance with the C.E.C. Part 1, and all local codes. The system should be grounded.

**USA** All electrical connections should be done in accordance with the National Electrical Code, and all local ordinances. The system should be grounded.

#### CONTROL BURNER OPERATION

Check out the burner and explain its operation to the homeowner. Be sure to leave the Owner's Instruction sheet with the homeowner.

#### FIRE EXTINGUISHER

If required by local codes, install an approved fire extinguisher.

#### ELECTRICAL CONNECTIONS

In most localities, a number 14 wire should be used inside a metal conduit. The system should be grounded. A service switch should be placed close to the burner on a fireproof wall in an easily accessible location.



#### RETROFIT APPLICATIONS ONLY

If this burner is being installed in a packaged unit (ie. burner comes with a boiler or furnace), follow the installation and set-up instructions supplied with the heating unit, as settings may differ from those shown in this manual.

- The following pages contain information, descriptions and diagrams for the proper installation and wiring of the burner. Please read carefully before attempting final installation.
- This manual is to remain with the final installation designation. It is the installer's responsibility to ensure that the burner installation and operation instructions mentioned in this manual are followed and operated within local code authority limits.



The burner settings used in this manual were obtained under laboratory conditions and may vary from those obtained in the actual installation of the burner. Combustion results must be verified using proper combustion test equipment. The Manufacturer will not be responsible for the improper installation or set-up of the appliance.

**4.3 Preliminary checks**

**Checking the consignment**



After removing all the packaging, check the integrity of the contents. In the event of doubt, do not use the burner; contact the supplier.



The packaging elements (wooden cage or cardboard box, nails, clips, plastic bags, etc.) must not be abandoned as they are potential sources of danger and pollution; they should be collected and disposed of in the appropriate places.



The output of the burner must be within the boiler's firing rate;



A burner label that has been tampered with, removed or is missing, along with anything else that prevents the definite identification of the burner makes any installation or maintenance work difficult.

**4.4 Installer/Service notes for the use of Gas oil with Bio blends up to 20%**

When installing the burner, make sure the fuel to be used is light oil. In the case of light oil with a bio blend up to 20%, the latter must comply with the manufacturer specifications (refer to "Technical data" and "Instructions for using biofuel blends up to 20%"). If a bio blend is in use the installer must seek information from the end user that their fuel supplier can evidence that the blends of fuel conform to the relevant standards. Check that the materials used in the construction of the oil tank and ancillary equipment are suitable for biofuels, If not these must be upgraded or replaced with bio-compatible parts. Particular attention should be given to the oil storage tank and supply to the burner. The manufacturer recommends that existing oil storage tanks are cleaned, inspected and any traces of water are removed before biofuel is introduced (contact the tank manufacturer or oil supplier for further advice). If these recommen-

dations are not respected this will increase the risk of contamination and possible equipment failure. In line oil filters should be replaced making sure that they are bio-compatible. The manufacturer recommends a good quality bio-compatible oil filter at the tank and a secondary 60 micron filter be used to protect the burner pump and nozzle from contamination. The burner hydraulic components and flexible oil lines must be suitable for biofuel use (check with the manufacturer if in doubt). The burner must be commissioned and combustion parameters set to appliance manufacturer's recommendations. Regularly check visually for any signs of oil leakage from seals, gaskets and hoses. It is strongly recommended that with biofuel use, oil filters are inspected and replaced every 4 months. More regularly where contamination is experienced.

**4.5 Operating position**



The burner is designed to work only in positions 1, 2, 3 and 4 (Fig. 5).

Installation 1 (Fig. 5) is preferable, as it is the only one that allows the maintenance operations as described later in this manual.

Installation 4 (Fig. 5) allows it to operate but not with maintenance with hooking to the boiler.

Any other position could compromise the correct operation of the appliance.



Any other positioning could compromise the correct operation of the appliance.

Installations 3 and 5 (Fig. 5) are forbidden for safety reasons.

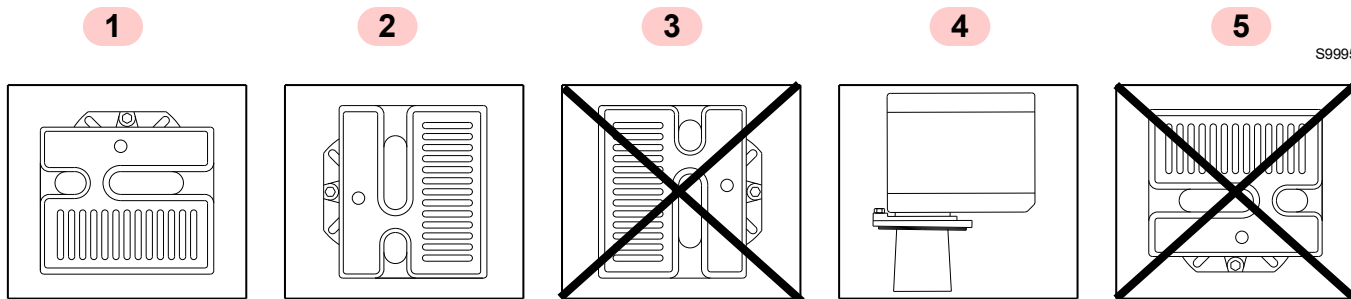

S9995

Fig. 5

### 4.6 Initial set-up



Provide an adequate lifting system of the burner.

- A Remove burner and air tube from cartons. Check parts list (inside cover) to ensure all parts are present.
- B Remove burner cover by loosening the three screws securing it. Remove flame control and air tube cover.

- C Remove drawer assembly from air tube, insert nozzle and set turbulator adjustment for specific input required, then set aside.
- D Mount air tube to burner chassis.

### 4.7 Assembly of air tube to burner chassis

The air tube and drawer assembly are shipped in a carton separate from the burner chassis. Choose the proper air tube length to obtain the tube insertion for the specific installation.

- A Remove the air tube and burner chassis from their respective cartons.
- B Remove the drawer assembly 1) from inside the air tube by loosening the screw 2). Carefully pull the drawer assembly out of the air tube, install the required nozzle (see page 6) and set aside.
- C Align the two holes on the air tube holding plate 5) with the two holes left open on the burner chassis front plate 4) with the bolts 3) removed.
- D Replace the bolts and finger tighten only. Re-install drawer assembly into air tube. Tighten screw 2) securely. Tighten the two bolts 3) securely.

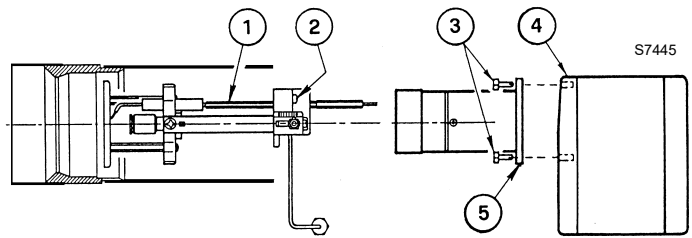

Fig. 6

### 4.8 Mounting the burner to the boiler

There are three possible methods to mount the burner, depending on the individual application. These are:

- 1 Universal flange bolted to Boiler/Furnace unit.
- 2 Semi-flange collar bolted to Boiler/Furnace unit.
- 3 Universal flange mounted to optional Pedestal mount, where flange mounting direct to appliance is not possible. Pedestal kit must be ordered separately.



**WARNING**

The seal between burner and boiler must be air-tight.

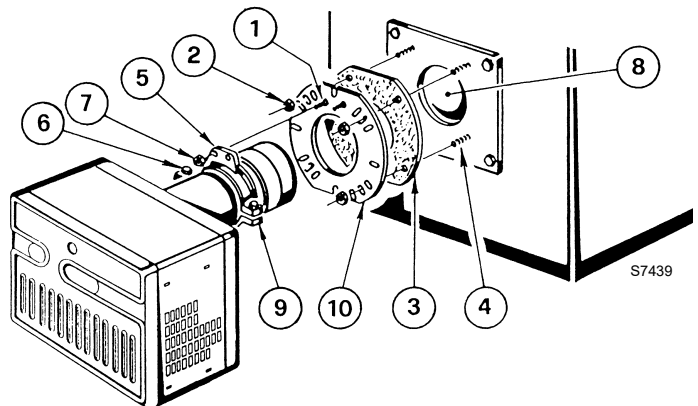

Fig. 7

#### 4.8.1 Method 1 – Universal mounting flange

- A Insert the two bolts 1) into the universal mounting flange 10) from the flat side, ensuring the bolt heads are flush with the flat surface. Secure in place using two special chrome nuts 2) provided.
- B Position the mounting gasket 3) between the flat surface of the universal mounting flange 10) and the appliance. Line up the holes in the universal mounting flange with the studs 4) on the appliance mounting plate and securely bolt the universal mounting flange to the plate.
- C Secure the two semi-flanges of the adjustable collar 9) to the air tube using the two long bolts 6). Be sure that the adjustable collar 9) is properly positioned so the outside edge of the end cone will be at least 1/4 inch (6.5 mm) back from the inside wall of the refractory of the combustion chamber (see dimension B above). The measured length (A) is to include mounting gasket and flange, if used.
- D The burner may now be attached to the heating unit by inserting the air tube through the burner access hole 8) and into the appliance, making sure the bolts 1) line up with the two holes 5) in the adjustable collar 9). Secure the burner in place using two nuts 7).

A visual verification of the air tube insertion into the combustion chamber of the heating unit is suggested. Dimension B should be at least 1/4" (see Fig. 8).

#### NOTE:

**A suggested method for creating mounting bolt holes in the mounting gasket: Hold the gasket against the appliance mounting bolts using the mounting flange for proper positioning. Lightly tap the flange with a hammer to form the holes.**

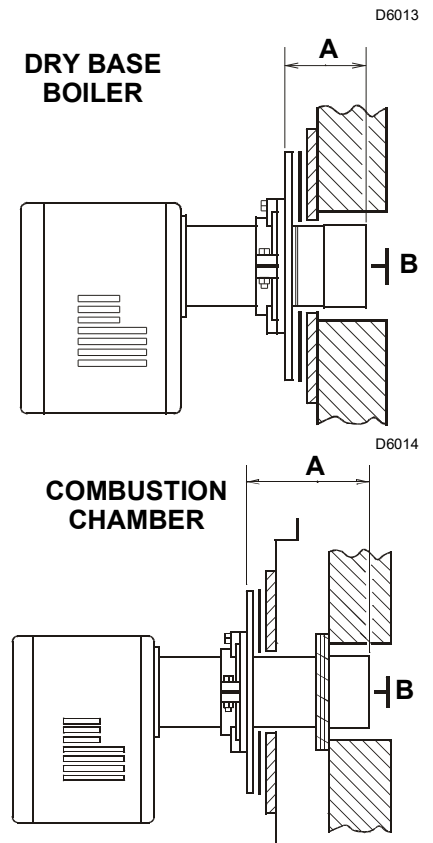

Fig. 8

#### 4.8.2 Method 2 – Semi-flange collar

- A Follow item C from Method 1.
- B Align the air tube and attached adjustable collar so air tube is centered in the burner access hole of the boiler/furnace unit. Mark the center of the two holes in the adjustable collar on to the front plate of the heating unit. Then drill 1/4 inch (6.5 mm) holes through the front plate of the unit, using marks as a guide.
- C Install two short bolts 1) through the front plate of the heating unit from the inside, and secure on the outside using the two special chrome nuts 2).
- D Follow item D from Method 1.

#### 4.8.3 Method 3 – Pedestal mount

Secure the mounting flange to mounting pedestal using the hardware provided with the pedestal. Secure burner to mounting flange as in Method 1, item A, C and D.

#### NOTE:

**It is suggested that the pedestal be anchored in position on the floor by installing brackets over the pedestal tube and securing brackets to the floor.**



WARNING

**When the combustion chamber is lined with a refractory material, it is imperative that the end cone not protrude into the chamber area, as excessive heat at burner shut down will damage the end cone.**

### 4.9 Installation/removal of drawer assembly

- A To remove drawer assembly, loosen screw 3), then unplug flame control 1) by carefully pulling it back and then up.
- B Remove the air tube cover plate 5) by loosening the two retaining screws 4).
- C Loosen screw 2), then slide the complete drawer assembly out of the combustion head as shown.
- D To insert drawer assembly, reverse the procedure in items A to C above, then attach fuel line to the pump.

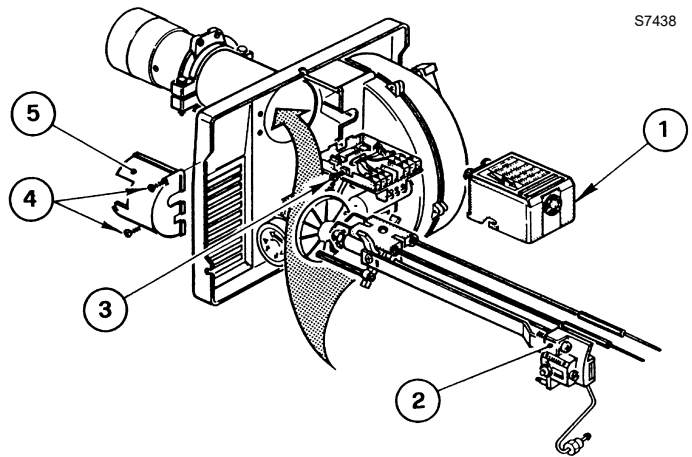

Fig. 9

### 4.10 Electrode setting



These dimensions must be observed and verified.

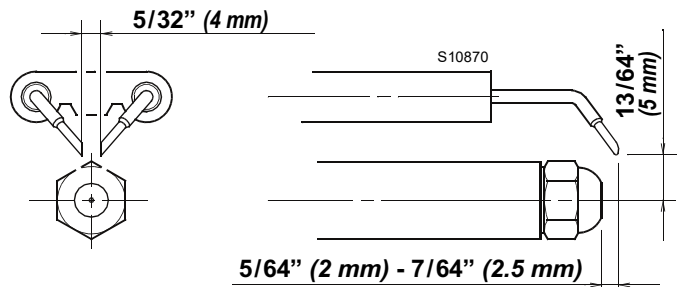

Fig. 10

**4.11 Nozzle**

In order to guarantee that emissions do not vary, recommended and/or alternative nozzles specified by the Manufacturer in the instruction and warning booklet should be used.



**WARNING**

It is advisable to replace nozzles every year during regular maintenance operations.



**CAUTION**

The use of nozzles other than those specified by the Manufacturer and inadequate regular maintenance may result into emission limits non-conforming to the values set forth by the regulations in force, and in extremely serious cases, into potential hazards to people and objects.

The manufacturing company shall not be liable for any such damage arising from non observance of the requirements contained in this manual.

**4.11.1 Nozzle placement**

- Determine the proper firing rate for the boiler or furnace units, considering the specific application, and then use the "Burner start-up cycle" to select the proper nozzle and pump pressure to obtain the required input from the burner.
- Remove the nozzle adapter 2) from the drawer assembly by loosening the screw 1).
- Insert the proper nozzle into the nozzle adapter and tighten securely.



**WARNING**

**Do not over tighten!**

- Replace adapter, with nozzle installed, into drawer assembly and secure with screw 1).



**WARNING**

The nozzle and the pump pressure must be in accordance with the burner setup chart on page 27.

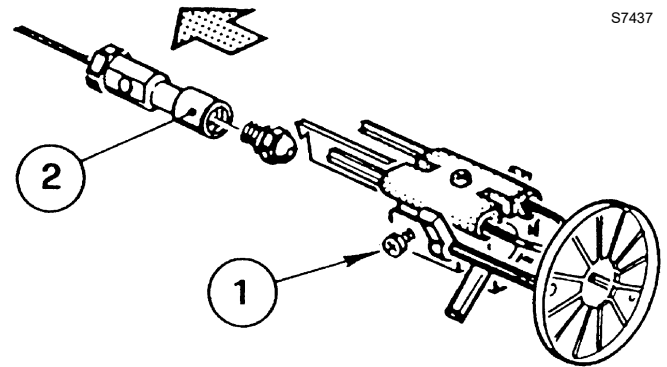

S7437

**Fig. 11**

**4.12 Turbulator setting**

Loosen nut 1), and then turn screw 2) until the index marker 3) is aligned with the correct index number as per the Burner Setup charts, or OEM specifications given with the appliance.



**WARNING**

Re-tighten the retaining nut 1).

**NOTE:**

Zero and five are scale indicators only. From left to right the first line is 5 and the last line 0.

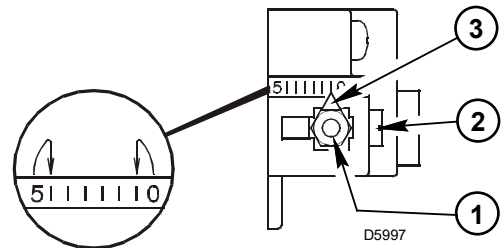

D5997

**Fig. 12**

### 5

### Hydraulic systems

#### 5.1 Oil line connections



Explosion danger due to fuel leaks in the presence of a flammable source.

Precautions: avoid knocking, attrition, sparks and heat.

Make sure the fuel interception tap is closed before performing any operation on the burner.



WARNING

The fuel supply line must be installed by qualified personnel, in compliance with current standards and laws.



WARNING

Where light oil containing bio diesel is in use, it is recommended to avoid over oxygenation of the blended fuels. Where at all possible avoid the use of two-pipe systems where the circulated fuel is returned to the tank. If this cannot be avoided make sure that the return pipe is normally below the surface of the fuel level within the storage tank.



WARNING

In case of use with light oil containing up to 20% bio blend, it will be essential to use flexible oil lines suitable for biofuel use. Please contact the manufacturer for further information.

Check periodically the flexible pipes conditions. If necessary, install a filter on the fuel supply line.



WARNING

The suction hose is identified by a specific label (see Fig. 13).

#### 5.2 Pump

The burner is shipped from the factory with the pump set to operate on a TWO line system.



WARNING

- This burner must be installed with a two line system to allow the hydraulic delay valve to operate.
- Pump pressure must be set at time of burner start-up. A pressure gauge is attached to the pressure port 1) for pressure readings.

Two pipe connectors 2) are supplied with the burner for connection to either a single or a two-pipe system. Also supplied are two adapters 3), two female 1/4" NPT, to adapt oil lines to burner pipe connectors. All pump port threads are British Parallel thread design. Direct connection of NPT threads to the pump will damage the pump body.

Riello manometers and vacuum gauges do not require any adapters, and can be safely connected directly to pump ports. An NPT (metric) adapter must be used when connecting other gauge models.

#### NOTE:

If the pump cover 4) is removed for any reason, be sure the O-ring 5), is properly seated in the pump cover (4) before re-attaching the pump cover to the pump housing.

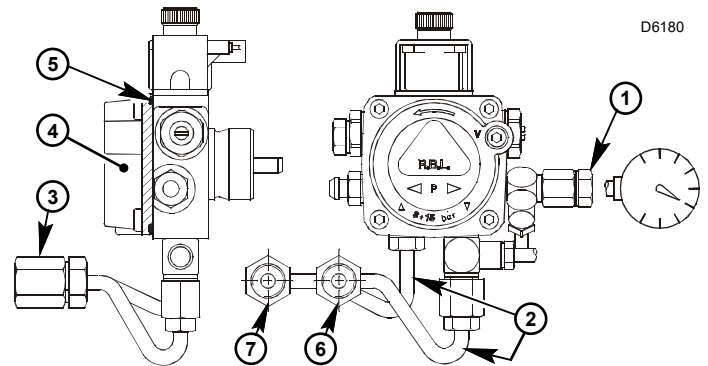

Fig. 13

**5.2.1 Two line (lift system)**

- A The burner is shipped with the pump set to operate on a two line system. Suction and return lines (6 & 7 in Fig. 13) should be the same diameter and both should extend to the same depth inside the fuel tank. Be sure there are no air leaks or blockages in the piping system. Any obstructions in the return line will cause failure of the pump shaft seal. Do not exceed the pipe lengths indicated in the Tab. H.
- B Attach the two pipe connectors 2) to the pump suction and pump return ports (6 and 7). Attach the required piping to these two pipe connectors using the NPT/METRIC adapters that are supplied with the burner.

**2 Line (Lift) System - Pipe Lengths**

H		3/8" OD		1/2" OD	
Feet	Meters	Feet	Meters	Feet	Meters
0	0.0	115	35	330	100
1 1/2	0.5	100	30	330	100
3	1.0	80	25	330	100
5	1.5	65	20	295	90
6 1/2	2.0	50	15	230	70
9 1/2	3.0	25	8	100	30
11	3.5	20	6	65	20

**Tab. H**

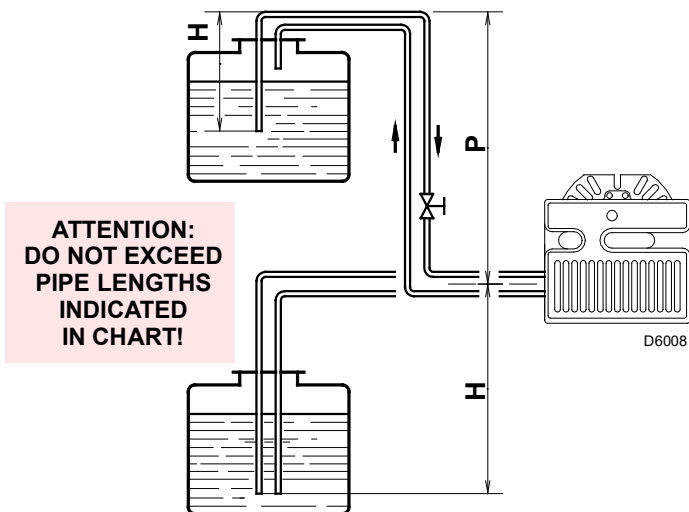

**Fig. 14**



- Pipe dope or Teflon tapes are NOT to be used on any direct oil connection to the fuel pump.
- The height 'P' in Pipe Length Charts should not exceed 13 feet (4 m).
- The vacuum should not exceed 11.44 inches of mercury.

**IMPORTANT:** An external, appropriately listed and certified oil filter must be placed in the fuel line between the fuel tank and the burner pump.

### 5.2.2 Pump purge



**WARNING**

Where light oil containing bio diesel is in use, it is recommended to avoid over oxygenation of the blended fuels. Where at all possible avoid the use of two-pipe systems where the circulated fuel is returned to the tank. If this cannot be avoided make sure that the return pipe is normally below the surface of the fuel level within the storage tank.



**WARNING**

In case of use with light oil containing up to 20% bio blend, it will be essential to use flexible oil lines suitable for biofuel use. Please contact the manufacturer for further information.

Check periodically the flexible pipes conditions. If necessary, install a filter on the fuel supply line.



**WARNING**

The suction hose is identified by a specific label (see Fig. 13).



**WARNING**

To protect the pump gears, it is advisable to lubricate the pump prior to purging a lift system. Apply oil through the vacuum port (A)(Fig. 15).

### 5.2.3 Two line (gravity or lift system)

- 1 Turn off the main power source to the burner and remove the air tube cover. Shine a light source on the flame sensor on the flame control (now visible where the air tube cover was removed), return power to the burner and activate the burner. With the light source in place, the burner will operate in prepurge only.
- 2 When the pump is sufficiently purged, the hydraulic air shutter will open.
- 3 Once the burner is purged, turn off the power source and replace the air tube cover. Return power to the burner. The burner is now ready to operate.

#### NOTE:

**To protect the pump gears, it is advisable to lubricate the pump prior to purging a lift system. Apply oil through the vacuum port (A).**

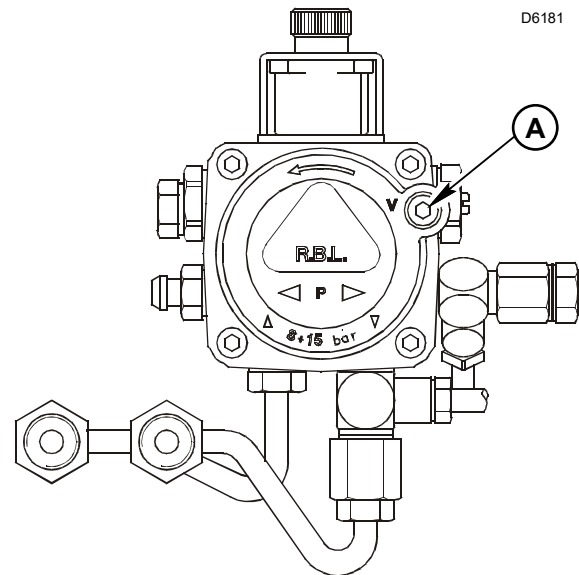

Fig. 15



**WARNING**

**It is important that the fuel line be completely sealed and free from air leaks or any internal blockages.**

**When the bypass plug is installed, a two pipe system must be used or failure of the pump shaft seal will occur.**

### 5.3 Air shutter setting

#### 5.3.1 Low fire setting

- A Loosen pressure releasing screw 1). (One turn is sufficient). This permits the fuel pressure to bleed off to the pump return port and the burner to operate continuously at the low fire rate.
- B Loosen retaining nut 2).
- C Turn the adjusting screw 3) until the top of the air shutter 9) is correctly positioned according to the Burner Set-up Chart, column 5, on page 10.
- D Use instruments to establish the proper settings for maximum CO<sub>2</sub> and a smoke reading of zero.
- E Hold adjusting screw 3) in position and secure by tightening RETAINING NUT 2).
- F Re-tighten pressure release screw 1).

**NOTE:**

The low fire pressure regulator is pre-set at the factory to 100 PSI (7 bar). To vary or regulate this pressure it is necessary to attach a pressure gauge to the pressure port 6). Loosen the pressure release screw 1) as in step A above. Regulate the pressure by turning the pressure regulating screw 5). The corresponding pressure can be read on the pressure gauge attached to the pump pressure port 6).

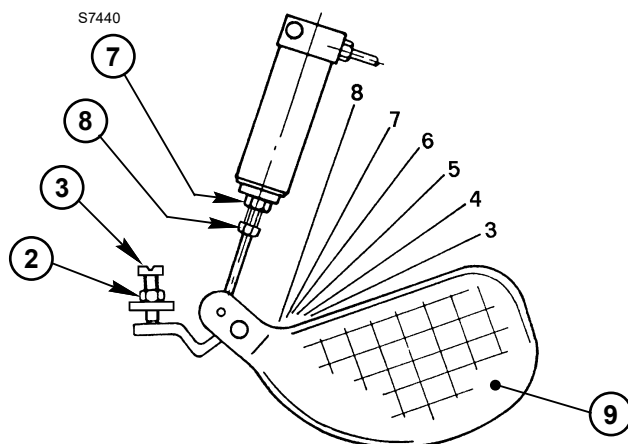

#### 5.3.2 Main flame setting

- A Be sure that the burner is operating at high fire.
- B Set the pump pressure by attaching a pressure gauge to the Pressure port 6) and adjust the pressure by turning the pressure regulator adjustment screw 10). Loosen the retaining nut 7), and turn the bolt 8) in a counterclockwise direction until about 3/4 of an inch of thread is visible. Using the setting taken from the Burner Set-up Chart, column 5, position the air shutter 9) so that the top of the shutter is aligned with the proper index line indicated on the air intake side of the burner housing. Holding the shutter in this position, turn adjusting bolt 8) in a clockwise direction until a resistance is met.
- C The final position of the air adjustment plate will vary on each installation. Use instruments to establish the proper settings for maximum CO<sub>2</sub> and a smoke reading of zero.

**NOTE:**

Variations in flue gas, smoke, CO<sub>2</sub> and temperature readings may be experienced when the burner cover is put in place. Therefore, the burner cover must be in place when making the final combustion instrument readings, to ensure proper test results.

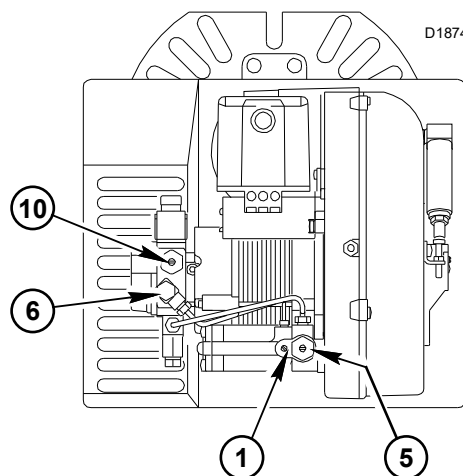

Fig. 16

### 6.1 Electrical wiring

#### Notes on safety for the electrical wiring

**DANGER**

- The electrical wiring must be carried out with the electrical supply disconnected.
- Electrical wiring must be made in accordance with the regulations currently in force in the country of destination and by qualified personnel. Refer to the wiring diagrams.
- The manufacturer declines all responsibility for modifications or connections different from those shown in the wiring diagrams.
- Do not invert the neutral with the phase in the electrical supply line.
- Check that the electrical supply of the burner corresponds to that shown on the identification label and in this manual.
- The burner has been type-approved for intermittent use. In the event of continuous operation, a cycle arrest must be ensured within 24 hours with the use of a time switch positioned in series with the thermostatic line. Refer to the wiring diagrams.
- The electrical safety of the device is obtained only when it is correctly connected to an efficient earthing system, made according to current standards. It is necessary to check this fundamental safety requirement. In the event of doubt, have the electrical system checked by qualified personnel.
- The electrical system must be suitable for the maximum power absorption of the device, as indicated on the label and in the manual, checking in particular that the section of the cables is suitable for that level of power absorption.
- For the main power supply of the device from the electricity mains:
  - do not use adapters, multiple sockets or extensions;
  - use a multiple pole switch with at least a 3 mm gap between the contacts (overvoltage category III), as envisaged by the present safety standards.
- Do not touch the device with wet or damp body parts and/or in bare feet.
- Do not pull the electric cables.

Before carrying out any maintenance, cleaning or checking operations:

**DANGER**

Disconnect the electrical supply from the burner by means of the main system switch.

**DANGER**

Close the fuel interception tap.

**DANGER**

Avoid condensate, ice and water leaks from forming.

If the cover is still present, remove it and proceed with the electrical wiring according to the wiring diagrams.

**6.1.1 Flame control**



**WARNING**

**It is advisable to leave the flame control off the sub-base while completing the electrical connections to the burner.**

- 1 Wire access hole (Use BX electrical connector)
- 2 Earth ground conductor terminal (Green wire)
- 3 Hot conductor terminal (Black wire)
- 4 Neutral conductor terminal (White wire)
- 5 Strain relief clamp



**DANGER**

The hot (black) wire must be connected to the L terminal and the neutral (white) wire must be connected to the N terminal or the primary safety control will be damaged.

Do not connect white wire to the terminal marked ⊗.

Using the appropriate diagram (Fig. 18 on page 26), make electrical connections to burner. All wiring must be done in accordance with existing electrical codes, both national and local.

When all electrical connections have been made, the flame control may be put back in place on the sub-base.



**WARNING**

**Do not activate burner until proper oil line connections have been made, or failure of the pump shaft seal may occur.**



**WARNING**

**The control panel is in compliance with UL508A.**

**NOTE:**

Terminal 4 (•) on the sub-base is to be used to activate a remote safety lockout circuit only. A 120V AC source is supplied to Terminal 4 upon lockout. The maximum allowable current draw for this circuit is 1 AMP.

**IMPORTANT:**

If a neutral or ground lead is attached to Terminal 4 (•) on the sub-base, the flame control will be damaged should lockout occur.

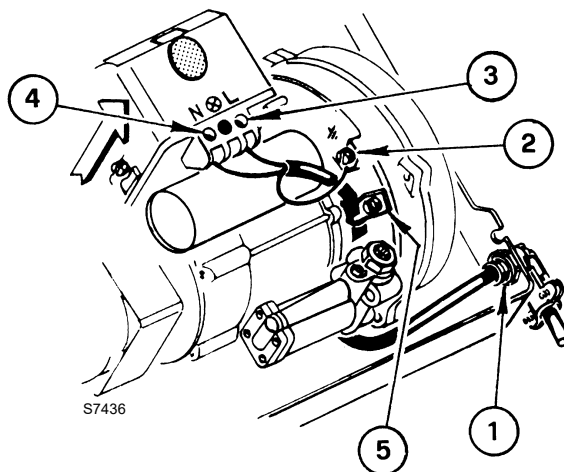
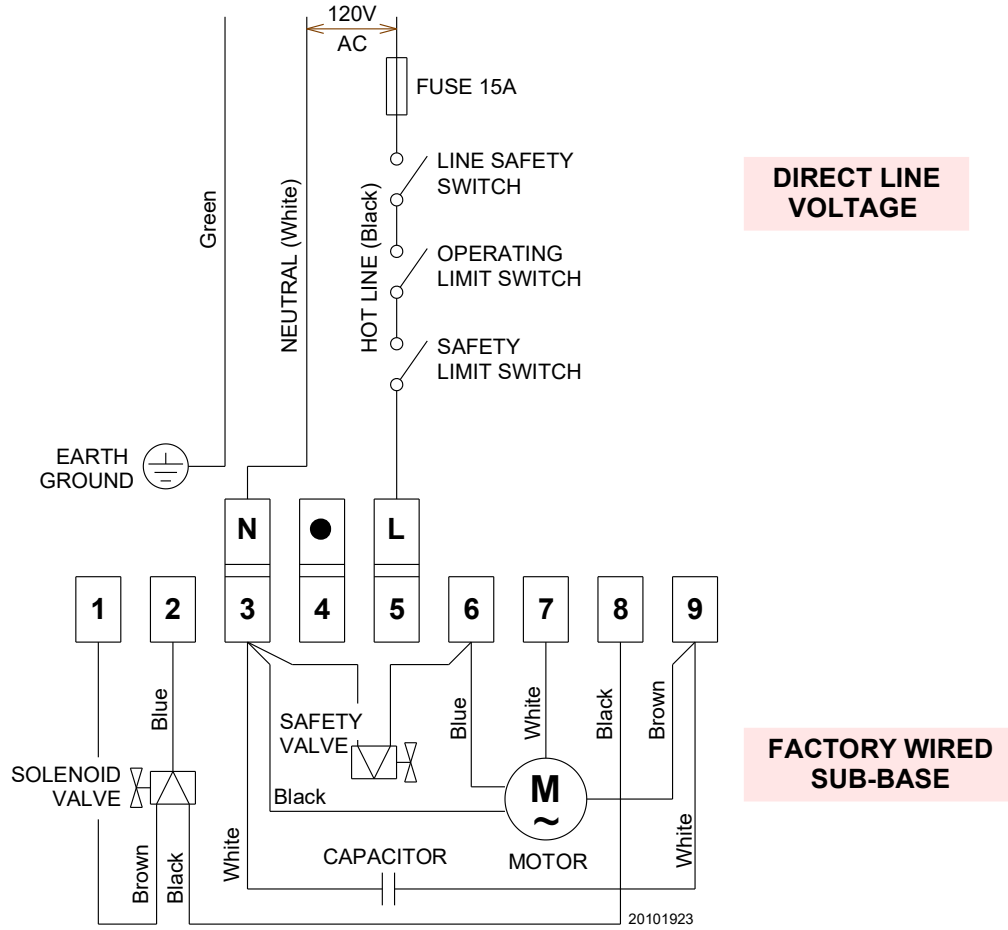

**Fig. 17**



After carrying out maintenance, cleaning or checking operations, reassemble the hood and all the safety and protection devices of the burner.

**6.1.2 Application field wiring**



**Fig. 18**

**6.2 Burner start-up cycle**

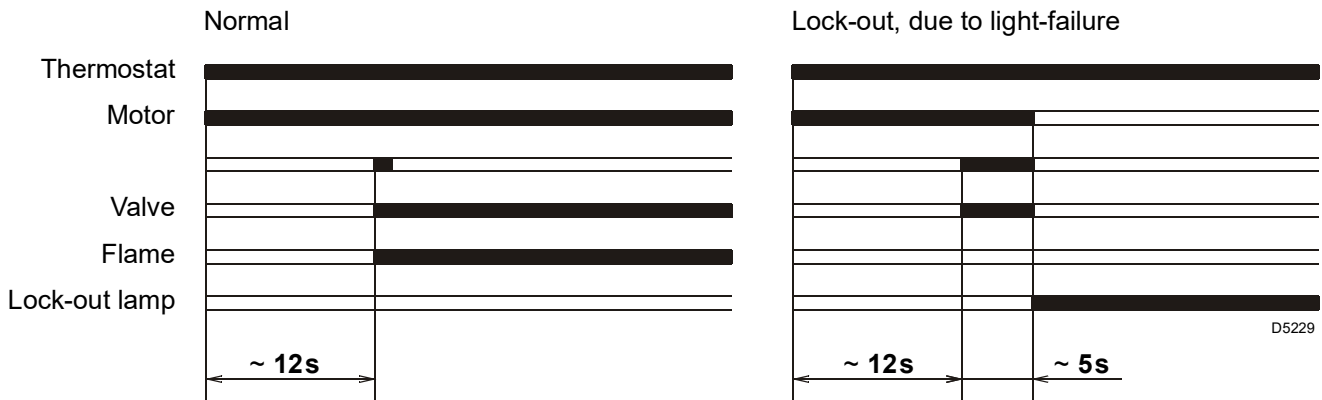

**Fig. 19**

**7**

**Start-up, calibration and operation of the burner**

**7.1 Notes on safety for the first start-up**



The first start-up of the burner must be carried out by qualified personnel, as indicated in this manual and in compliance with the standards and regulations of the laws in force.



Check the correct working of the adjustment, command and safety devices.

**7.2 Burner set-up chart**

**NON-RETROFIT APPLICATIONS**

If this burner is being installed in a packaged unit (ie. burner comes with a boiler or furnace), follow the installation and set-up instructions supplied with the heating unit, as settings will differ from those shown in this manual.

1		2	3		4	5	
Actual Firing Rate $\pm 5\%$		Nozzle Size	Pump Pressure		Turbulator Setting	Air Damper Setting	
GPH	Kg/h	GPH	PSI	bar		Low Fire	Main Flame
3.50	11.3	2.50 x 45°/60°	190	13.0	0.0	2.3	2.8
4.00	12.9	3.00 x 45°/60°	178	12.0	1.0	2.5	3.2
4.65	15.0	3.50 x 45°/60°	178	12.0	2.0	2.8	3.7
5.30	17.1	4.00 x 45°/60°	178	12.0	3.0	3.2	4.5
6.00	19.4	4.50 x 45°/60°	178	12.0	4.0	3.5	5.0
6.40	20.7	5.00 x 45°/60°	165	11.4	5.0	3.8	6.0

**Tab. I**

**NOZZLES RECOMMENDED:**

- Monarch R-PLP
- Delavan W-B
- Danfoss S-B
- Steinen SS-S
- Hago P

**COMBUSTION CHAMBER**

Follow the instructions furnished by the boiler/furnace manufacturer. Size retrofit application according to the appropriate installation codes (e.g. CSA B139 or NFPA #31).

**NOTE:**

A 45° degree nozzle is suggested, however, a 60° degree nozzle may be used in cases where the flame is unstable at light-off when operated at low ambient temperatures.

### 7.3 Ducted combustion air intake applications

The “Ducted combustion air intake kit” (see part number 3002762 in the spare parts list - OPTIONAL), allows ducting of external air directly into the burner. A 4” diameter air intake is provided in the kit.



**WARNING**

To mount this kit on the burner, please follow the installation description given in the kit instruction sheet. Use a 4” to 6” pipe adapter (not supplied in the kit) to use a 6” diameter pipe.

The settings of the burner must be according to the burner setup chart – air intake applications (Tab. J).

MODEL F20 BURNER SETUP CHART with 4" diameter pipe											
Actual firing rate GPH	Nozzle size	Pump pressure PSI	Head setting	20 Ft. pipe length		50 Ft. pipe length		80 Ft. pipe length		100 Ft. pipe length	
				Air setting		Air setting		Air setting		Air setting	
				Low fire	Main flame	Low fire	Main flame	Low fire	Main flame	Low fire	Main flame
3.50	2.50 x 45°/60°	195	0.5	2.3	2.9	2.3	2.9	2.3	3.0	2.5	3.0
4.00	3.00 x 45°/60°	177	2.0	2.4	3.1	2.4	3.3	2.4	3.5	2.6	3.8
4.65	3.50 x 45°/60°	176	3.5	2.9	3.9	3.0	4.2	3.0	4.5	3.5	5.0
5.16	4.00 x 45°/60°	160	5.0	3.1	4.8	3.2	5.0	3.3	5.0	3.8	5.8
MODEL F20 BURNER SETUP CHART with 6" diameter pipe											
Actual firing rate GPH	Nozzle size	Pump pressure PSI	Head setting	20 Ft. pipe length		50 Ft. pipe length		80 Ft. pipe length		100 Ft. pipe length	
				Air setting		Air setting		Air setting		Air setting	
				Low fire	Main flame	Low fire	Main flame	Low fire	Main flame	Low fire	Main flame
3.50	2.50 x 45°/60°	195	0.5	2.1	2.8	2.1	2.8	2.1	2.9	2.1	2.9
4.00	3.00 x 45°/60°	177	2.0	2.2	3.0	2.2	3.0	2.3	3.1	2.3	3.1
4.65	3.50 x 45°/60°	176	3.5	2.7	3.4	2.7	3.5	2.9	3.8	3.1	4.5
5.30	4.00 x 45°/60°	160	4.5	3.0	3.8	3.0	4.0	3.0	4.1	3.1	4.5
6.00	4.50 x 45°/60°	177	5.0	3.0	5.3	3.3	5.4	3.3	5.4	3.5	5.7

**Tab. J**

#### NOZZLES RECOMMENDED:

- Monarch R-PLP
- Delavan W-B
- Danfoss S-B
- Steinen SS-S
- Hago P

#### NOTE:

**A 45° degree nozzle is suggested, however, a 60° degree nozzle may be used in cases where the flame is unstable at light-off when operated at low ambient temperatures.**

- A This kit is not suitable for direct vent applications.
- B Always try to minimize the length of the air intake pipe.
- C Reduce pipe length by 10 feet for every 90° elbow, 5 feet for every 45° elbow.
- D Reduce pipe length by 6 feet for the 4” to 6” pipe adapter (if used).
- E Air intake venting should be insulated 10 feet from air intake source with a minimum R7 foil lined insulation, to prevent condensation or corrosion of air intake venting.

- F Use an approved type of air intake vacuum breaker and install it in the same room of the burner. This device should be tested to prove that the vacuum breaker balancer is set correctly and, in the event of intake air source being blocked, can provide enough combustion air for the burner. If the room where the burner is installed cannot provide enough air or air quality is a concern, an additional air inlet source must be provided to this room.
- G On the outside of the wall, use an approved intake air hood, located above the snow line and in such way as to prevent leaves and/or other debris from blocking the air flow. Refer to local codes for proper location of inlet.

#### COMBUSTION CHAMBER

Follow the instructions furnished by the boiler/furnace manufacturer. Size retrofit application according to the appropriate installation codes (e.g. CSA B139 or NFPA #31).

### 8.1 Notes on safety for the maintenance

The periodic maintenance is essential for the good operation, safety, yield and duration of the burner.

It allows you to reduce consumption and polluting emissions and to keep the product in a reliable state over time.



DANGER

The maintenance interventions and the calibration of the burner must only be carried out by qualified, authorised personnel, in accordance with the contents of this manual and in compliance with the standards and regulations of current laws.

Before carrying out any maintenance, cleaning or checking operations:



DANGER

Disconnect the electrical supply from the burner by means of the main system switch.



DANGER

Close the fuel shut-off valve.



Wait for the components in contact with heat sources to cool down completely.

### 8.2 Maintenance programme

#### 8.2.1 Maintenance frequency



The combustion system should be checked at least once a year by a representative of the manufacturer or another specialised technician.

#### 8.2.2 Checking and cleaning



The operator must use the required equipment during maintenance.

##### Filters

Clean the filter of the fuel suction line and of the pump. If rust or other impurities are observed inside the pump, use a separate pump to lift any water and other impurities that may have deposited on the bottom of the tank.

##### Fan

Check to make sure that no dust has accumulated inside the fan or on its impellers, as this condition will cause: a reduction in the air flow rate and provoke polluting combustion.

##### Combustion head

Check that all the parts of the combustion head are undamaged, not deformed by the high temperatures, free of all impurities and positioned correctly. Clean the combustion head in the fuel outlet area. Check that the positioning of the combustion head is correct and that it is properly fixed to the boiler.

##### Electrodes

Check the correct positioning of the electrodes (page 17).

##### Burner

Check for excess wear or loose screws and clean the outside of the burner.

##### Boiler

Clean the boiler as indicated in the appliance accompanying instructions in order to maintain all the original combustion characteristics intact, especially the flue gas temperature and combustion chamber pressure.

##### Nozzles

Do not clean the nozzle openings.



WARNING

It is advisable to replace nozzles every year during regular maintenance operations.

The change of nozzle requires the combustion to be controlled.

##### Hoses

- Check periodically the flexible pipes conditions. They have to be replaced at least **every 2 years**.
- In case of use of gas oil and bio fuel blends, it is strongly recommended to inspect **even more frequently** the hoses and replace them where contamination has occurred.
- Check to make sure that the hoses are still in good condition.

##### Fuel tank

If water or contamination is present within the fuel tank, it is essential that this is removed before the equipment is to be used. This is extremely important when gas oil containing Bio diesel is in use. If in doubt about how to achieve this then please contact the fuel or oil tank supplier.

### Pump

Delivery pressure must correspond with the table on Tab. I on page 27. Please check that the supply line and filters are clear. The use of a pump vacuum gauge will assist in this. This measure permits the cause of the anomaly to be traced to either the suction line or the pump.

If the problem lies in the suction line, check to make sure that the filter is clean and that air is not entering the piping.

### Combustion

In case the combustion values found at the beginning of the intervention do not respect the standards in force or, in any case, do not correspond to a proper combustion, contact the Technical Assistant and have him carry out the necessary adjustments.

Allow the burner to work for 10 min. and then check the combustion readings with the parameters indicated within the appliance instruction manual. **Then carry out a combustion check**

#### verifying:

- Smoke temperature at the chimney;
- Content of CO<sub>2</sub> (%);
- Content of CO (ppm);
- Smoke value according to opacity smokes index according to Bacharach scale.

### Fuel oil

Your burner is not to be used with oil heavier than No. 2. Never use gasoline, crankcase oil or any oil containing gasoline.

### Combustion air

An adequate air supply is required for proper combustion. Do not block the flow of air into your furnace or boiler room. Details on air requirements are found in your installation manual.

### Oil filter

The oil line filter cartridge should be replaced annually, and the filter container thoroughly cleaned by your service technician.

### Motor

The motor on your Riello oil burner is permanently lubricated and does not require oiling.



**WARNING**

NEVER try to light oil by putting burning material into the furnace or boiler.

DO not store combustible or flammable material near your heating appliance.

There are no owner serviceable parts inside the burner cover do not tamper with the unit or controls. call your service technician.

### 8.2.3 Safety components

The safety components must be replaced at the end of their life cycle indicated in Tab. K.

The specified life cycles do not refer to the warranty terms indicated in the delivery or payment conditions.

Safety component	Life cycle
Flame control	10 years or 250.000 operation cycles
Flame sensor	10 years or 250.000 operation cycles
Gas valves (solenoid)	10 years or 250.000 operation cycles
Pressure switches	10 years or 250.000 operation cycles
Pressure adjuster	15 years
Servomotor (electronic cam) (if present)	10 years or 250.000 operation cycles
Oil valve (solenoid) (if present)	10 years or 250.000 operation cycles
Oil regulator (if present)	10 years or 250.000 operation cycles
Oil pipes/ couplings (metallic) (if present)	10 years
Fan impeller	10 years or 500.000 start-ups

**Tab. K**



**WARNING**

The manufacturer cannot accept responsibility for any damage to persons, animals or property due to error in installation or in the burner adjustment, or due to improper or unreasonable use or non observance of the technical instruction enclosed with the burner, or due to the intervention of unqualified personnel.

**9**

**Faults / Solutions**

Here below you can find some causes and the possible solutions for some problems that could cause a failure to start or incorrect operation of the burner.

A fault usually makes the lockout LED signal which is situated inside the reset button of the flame control.

When lockout lamp comes on the burner will attempt to light only after pushing the reset button. After this if the burner functions correctly, the lockout can be attributed to a temporary fault that is not dangerous.

If however the lockout continues the cause must be determined and the solution found.

FAULTS	POSSIBLE CAUSE	SOLUTION
<b>The burner does not start when the limit thermostat closes.</b>	Lack of the power supply. Check the external main fuse.	Check the power supply in the rear side of the CF on L-N pins when heat demands (thermostats) are closed. Replace the main fuse. Replace the control flame.
	Heater or enabling thermostats are faulty.	Check that safety thermostat is not lock out. Replace them.
	The connections in the flame control are wrongly inserted.	Check and connect completely all the plugs.
<b>The burner remains in pre-purge.</b>	The flame sensor sees the extraneous light. Flame sensor is in short circuit. Coil of the EV is broken (open circuit)	Eliminate the light. Check if there is an extraneous light in the chamber. Replace the flame sensor Check the coil wiring on the socket or replace the EV coil.
<b>Burner runs normally in the prepurge and ignition cycle and locks out after 5 seconds ca.</b>	The flame sensor is dirty.	Clear it.
	The flame sensor is faulty.	Replace it.
	Flame moves away or fails.	Check pressure and output of the fuel.
		Check air output. Change nozzle. Check the coil of solenoid valve.
<b>Burner starts with an ignition delay.</b>	The ignition electrodes are wrongly positioned. The electrodes are broken	Adjust them according to the instructions of this manual. Replace the electrodes
	Air output is too high.	Set the air output according to the instructions of this manual.
	Nozzle dirty or worn.	Replace it.
<b>The burner goes into lock-out mode during operation.</b>	The flame disappears during the running phase.	Clean or replace the flame sensor.
		Replace the dirty or deteriorated nozzle. Check the combustion.
	Failure to go off.	Check the efficiency of the flame sensor. Clean or replace the flame sensor.
		Check the combustion according to the burner power rate indicated in this document.
		Check the efficiency of the pump cut off valve and filters. Check the oil comes to the pump. There is air inside the pump: vent the pump.

Tab. L

## 10

## Appendix - Accessories

**BFODD AL1009 retrofit kit**

Burner	Code
RIELLO 40 F20 B20	C7001084

**24V switching relay AL1008 retrofit kit**

Burner	Code
RIELLO 40 F20 B20	C7001085

**Ducted combustion air intake kit**

Burner	Code
RIELLO 40 F20 B20	3002762

**Bag of fittings**

Burner	Code
RIELLO 40 F20 B20	C7001015

**Semi-flange kit**

Burner	Code
RIELLO 40 F20 B20	C7001020

**Gauge adapter kit**

Burner	Code
RIELLO 40 F20 B20	C7001071

**Vacuum & Pressure Tester Manifold T20**

Burner	Code
RIELLO 40 F20 B20	C7050010

**Flange extension**

Burner	Code
RIELLO 40 F20 B20	C7050011

**B20 retrofit kit**

Burner	Code
RIELLO 40 F20 B20	20193043



The installer is responsible for the addition of any safety device not foreseen in this manual.

11

**Burner start-up report**

Model number:	_____	Serial number:	_____
Project name:	_____	Start-up date:	_____
Installing contractor:	_____	Phone number:	_____

**LIGHT OIL OPERATION**

Oil supply pressure:	_____	CO <sub>2</sub> : Low Fire	_____	High Fire	_____
Oil suction pressure:	_____	O <sub>2</sub> : Low Fire	_____	High Fire	_____
Control Power Supply:	_____	CO: Low Fire	_____	High Fire	_____
Burner Firing Rate:	_____	NO <sub>x</sub> : Low Fire	_____	High Fire	_____
Low Fire Flame Signal:	_____	Net Stack Temp - Low Fire:	_____	High Fire	_____
High Fire Flame Signal:	_____	Comb. Efficiency - Low Fire:	_____	High Fire	_____
Low Fire Nozzle Size:	_____	Overfire Draft:	_____		
High Fire Nozzle Size:	_____	Smoke number:	_____		

**CONTROL SETTINGS**

Operating Setpoint:	_____	Low Oil Pressure:	_____
High Limit Setpoint:	_____	High Oil Pressure:	_____
Low Gas Pressure:	_____	Flame Safeguard Model Number:	_____
High Gas Pressure:	_____	Modulating Signal Type:	_____

**NOTES**

---



---



---



---

**12 Spare parts**

**12.1 Exploded spare parts**

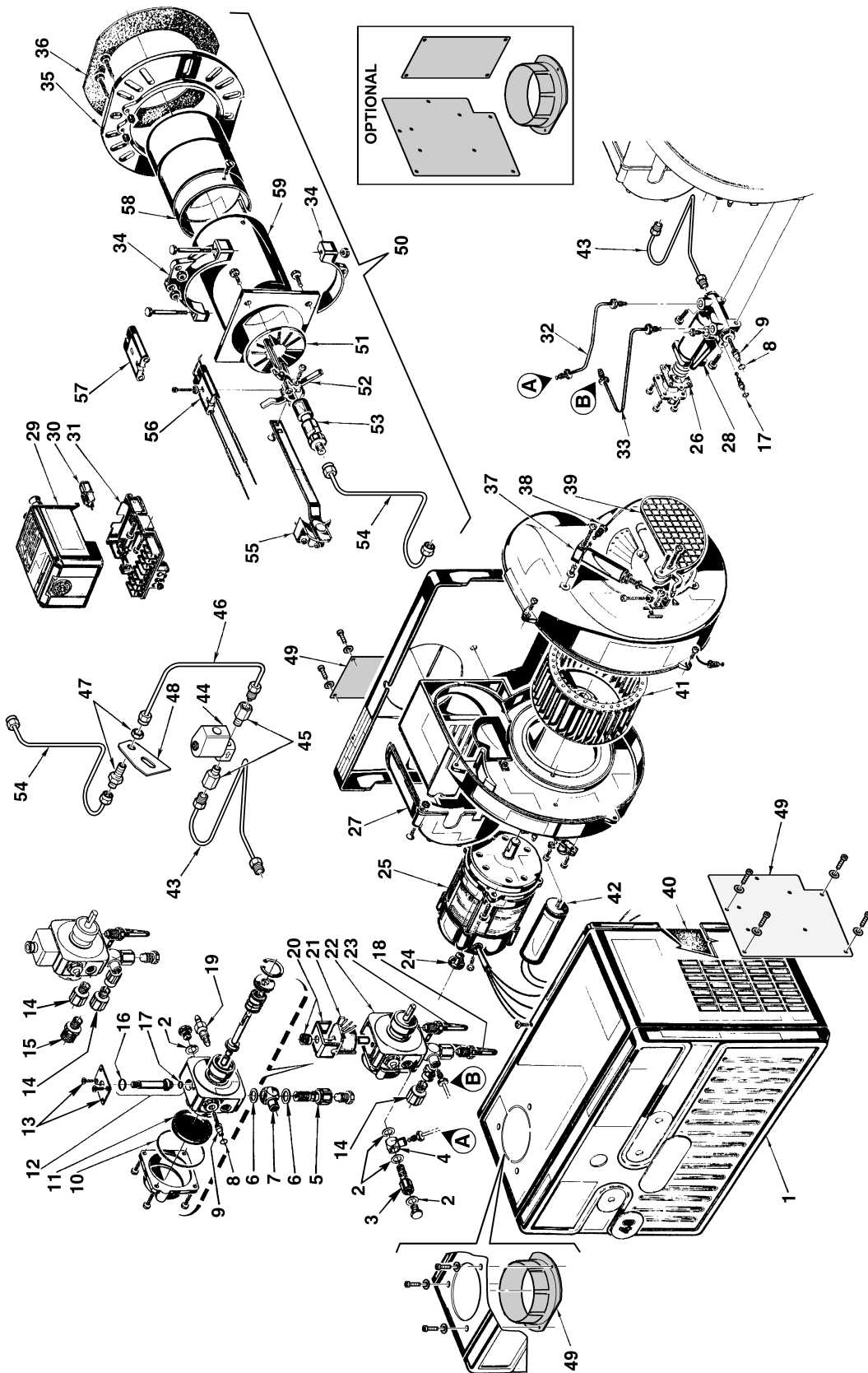

**12.2 Spare parts list**

N.	CODE	DESCRIPTION	BURNER SERIAL NUMBER	*
1	3020510	BURNER BACK COVER		
2	3007077	CRUSHABLE METAL WASHER		B
3	3005771	BANJO CORE ADAPTER - PRESSURE PORT		
4	3005803	BANJO FITTING - PRESSURE PORT		
5	3005804	BANJO CORE ADAPTER - RETURN LINE		
6	3007079	CRUSHABLE METAL WASHER		B
7	3005805	BANJO FITTING - RETURN		
8	3007028	O-RING - PUMP PRESSURE REGULATOR		B
9	3007202	REGULATOR SCREW		
10	3007175	O-RING - PUMP COVER		B
11	3005719	PUMP SCREEN		A
12	3007611	VALVE STEM		B
13	3007203	VALVE STEM PLATE		
14	3005847	1/4" NPT/ METRIC ADAPTER - FEMALE		
15	3006571	3/8" NPT/METRIC ADAPTER - MALE		
16	3007029	O-RING - VALVE STEM UPPER		B
17	3007156	O-RING - VALVE STEM LOWER		B
18	3006995	PIPE CONNECTOR - RETURN		
19	3007893	BLEEDER		
20	3006553	COIL U-BRACKET AND KNURLED NUT		
21	3002279	COIL		B
22	20194416	PUMP		C
23	3006994	PIPE CONNECTOR - SUPPLY		
24	3000443	PUMP DRIVE KEY		A
25	3005845	MOTOR		C
26	3005801	GASKET		B
27	3007318	AIR TUBE COVER		
28	3006500	HI FIRE DELAY VALVE		C
29	3001157	PRIMARY CONTROL 530SE/C		B
30	20132573	FLAME SENSOR		A
31	3002278	PRIMARY CONTROL SUB BASE		C
32	3005809	OIL PRESSURE TUBE		
33	3005808	OIL RETURN TUBE		
34	3005849	SEMI FLANGE		
35	3005851	UNIVERSAL MOUNTING FLANGE		
36	3005852	MOUNTING GASKET		A
37	3020444R	HYDRAULIC JACK		C

N.	CODE	DESCRIPTION	BURNER SERIAL NUMBER	*
38	<b>3008050</b>	CAPILLARY TUBE		
39	<b>3000645</b>	HYDRAULIC AIR SHUTTER		
40	<b>3007358</b>	ACOUSTIC LINER		
41	<b>3005799</b>	FAN		C
42	<b>20087024</b>	CAPACITOR 16 µF		B
43	<b>3020313</b>	OIL LINE		
44	<b>20191934</b>	SOLENOID VALVE		B
45	<b>3020304</b>	ADAPTOR		
46	<b>3020301</b>	OIL LINE		
47	<b>3020305</b>	ADAPTOR AND NUT		
48	<b>3020302</b>	BRACKET		
OPTIONAL				
49	<b>3002762</b>	DUCTED COMBUSTION AIR INTAKE KIT		
50	<b>20194381</b>	<b>SHORT COMBUSTION HEAD 5"</b>		
51	<b>3005897</b>	TURBULATOR DISC		A
52	<b>3005896</b>	CROSS - CASTING		
53	<b>20188411</b>	NOZZLE ADAPTER		C
54	<b>3006987</b>	NOZZLE OIL TUBE - SHORT		
55	<b>3005900</b>	REGULATOR ASSEMBLY - SHORT		
56	<b>3005902</b>	ELECTRODE ASSEMBLY - SHORT		A
57	<b>3005869</b>	ELECTRODE PORCELAIN		A
58	<b>3005894</b>	END CONE		C
59	<b>3005892</b>	SHORT AIR TUBE		
50	<b>20194383</b>	<b>LONG COMBUSTION HEAD 10"</b>		
51	<b>3005897</b>	TURBULATOR DISC		A
52	<b>3005896</b>	CROSS - CASTING		
53	<b>20188411</b>	NOZZLE ADAPTER		C
54	<b>3006988</b>	NOZZLE OIL TUBE - LONG		
55	<b>3005901</b>	REGULATOR ASSEMBLY - LONG		
56	<b>3005903</b>	ELECTRODE ASSEMBLY - LONG		A
57	<b>3005869</b>	ELECTRODE PORCELAIN		A
58	<b>3005894</b>	END CONE		C
59	<b>3005893</b>	LONG AIR TUBE		

\*

## ADVISED PARTS

A = Spare parts for minimum fittings

A+B = Spare parts for basic safety fittings

A+B+C = Spare parts for extended safety fittings



---

# RIELLO

RIELLO S.p.A.  
I-37045 Legnago (VR)  
Tél.: +39.0442.630111  
[http:// www.riello.com](http://www.riello.com)

---

# RIELLO

35 Pond Park Road  
Hingham, Massachusetts,  
U.S.A. 02043

RIELLO BURNERS NORTH AMERICA

**1-800-4-RIELLO**  
1-800-474-3556

<http://www.riello.ca>

2165 Meadowpine Blvd  
Mississauga, Ontario  
Canada L5N 6H6