

**Kit distanziale - Kit entretoise**  
**Spacer kit - Distanzstück kit**

**3010095**

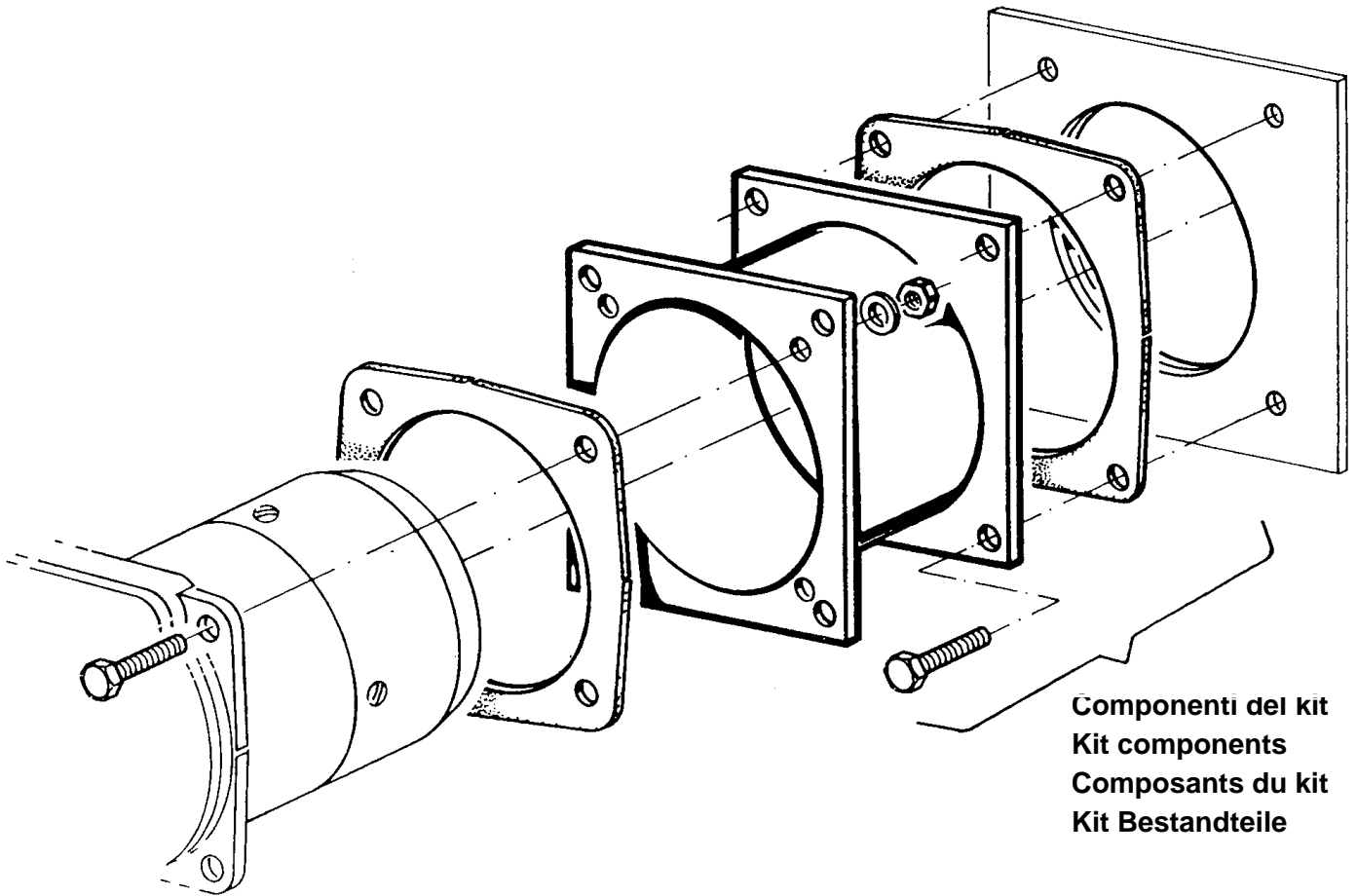

**Componenti del kit**  
**Kit components**  
**Composants du kit**  
**Kit Bestandteile**

**ITALIANO**



**PERICOLO**

Tutte le operazioni di installazione, manutenzione e smontaggio devono assolutamente essere eseguite con rete elettrica staccata.



**ATTENZIONE**

L'installazione del bruciatore deve essere effettuata da personale abilitato, secondo quanto riportato nel presente manuale ed in conformità alle norme e disposizioni di legge vigenti.

**FRANÇAIS**



**DANGER**

Toutes les opérations d'installation, entretien et démontage doivent être effectuées avec le réseau électrique débranché.



**ATTENTION**

L'installation du brûleur doit être effectuée par du personnel habilité, selon les indications reportées dans ce manuel et conformément aux normes et dispositions en vigueur.

**DEUTSCH**



**GEFAHR**

Alle Arbeiten zur Installation, Wartung und Demontage müssen unbedingt bei abgeschaltetem Stromnetz ausgeführt werden.



**ACHTUNG**

Die Installation des Brenners muss durch Fachpersonal gemäß den Angaben in diesem Handbuch sowie in Übereinstimmung mit den gültigen gesetzlichen Normen und Bestimmungen ausgeführt werden.

**ENGLISH**



**DANGER**

All the installation, maintenance and disassembly operations must be carried out with the electricity supply disconnected.



**WARNING**

The installation of the burner must be carried out by qualified personnel, as indicated in this manual and in compliance with the standards and regulations of the laws in force.