

RTC 1000-5500 -80

USA INSTALLATION, OPERATION AND SERVICE MANUAL

RIELLO

Dear heating engineer,
Congratulations for purchasing a **RIELLO** boiler. This appliance ensures maximum performance throughout an extended operating life, with high reliability, efficiency, quality and safety. This manual provides information that is essential to the installation of the appliance. Used in conjunction with your own knowledge and expertise, it will enable you to install the appliance quickly, easily, and correctly.

Please accept our thanks, and congratulations on your choice of product.
Riello S.p.A.

RANGE

MODEL	CODE
RTC 1000-80	20165080
RTC 1300-80	20166926
RTC 1700-80	20166937
RTC 2300-80	20166942
RTC 3000-80	20166947
RTC 3800-80	20166962
RTC 4700-80	20166970
RTC 5500-80	20166987

CONFORMITY



CONTENTS

1 GENERAL	4	3 COMMISSIONING	47
1.1 General safety information.....	4	3.1 Preparing for initial startup.....	47
1.2 General safety instructions.....	4	3.2 Third party control units.....	48
1.3 Description of the appliance.....	6	3.3 Hydraulic connection to the heating system.....	48
1.4 Identification.....	6	3.4 Making the electrical connection.....	48
1.5 System layout.....	7	3.5 Fitting temperature sensors.....	48
1.6 Technical specifications.....	8	3.6 Flushing the heating system.....	49
1.6.1 Ratings (natural gas firing).....	8	3.7 Filling the heating system.....	49
1.6.2 Ratings (oil firing).....	8	3.8 Preparing the heating system for operation.....	49
1.6.3 Specifications.....	9	3.9 Commissioning the control unit and burner.....	49
1.7 Intended use.....	10	3.10 Commissioning report.....	50
1.8 Certification and test mark.....	10	4 SHUTDOWN	51
1.9 Regulations and guidelines.....	10	4.1 Shutting down the heating system.....	51
1.9.1 National regulation.....	10	4.2 Shutting down the heating system in an emergency..	51
1.9.2 Compliance with standards and regulations.....	10	5 INSPECTION AND MAINTENANCE	52
1.9.3 Additional regulations for installations in the Commonwealth of Massachusetts.....	10	5.1 Why is regular maintenance important?.....	52
1.10 Suitable fuels.....	11	5.2 Maintenance.....	52
1.11 Burners.....	11	5.3 Cleaning the boiler.....	53
1.11.1 Recommended burners and burner plate accessories kit12		5.4 External cleaning.....	54
2 INSTALLATION	14	5.5 Checking and correcting the water pressure.....	54
2.1 Unpacking the product.....	14	5.6 Boiler inspection - water-side.....	54
2.2 Overall dimensions and weights.....	15	5.6.1 Inspection and maintenance reports.....	55
2.3 Moving and removing the packaging.....	16	5.7 Troubleshooting.....	56
2.4 Installation premises.....	17	6 ENVIRONMENTAL PROTECTION/DISPOSAL	57
2.4.1 Installation clearances.....	17		
2.4.2 Minimum clearance to combustibles.....	18		
2.5 Water connections.....	19		
2.6 Sensor manifold installation.....	21		
2.7 Sensor manifold connections.....	22		
2.8 Positioning of sensor sockets.....	23		
2.8.1 Water-side pressure drop.....	25		
2.8.2 Flow limits.....	26		
2.8.3 Water quality requirements.....	26		
2.8.4 Central heating system.....	26		
2.8.5 New central heating systems.....	26		
2.8.6 Reconditioning old heating systems.....	27		
2.8.7 Elimination of air and gas from central heating system	27		
2.8.8 Use of antifreeze.....	27		
2.8.9 Glycol.....	27		
2.9 Typical water system schematics.....	29		
2.10 Draining the condensate.....	37		
2.11 Neutralizing the condensate.....	37		
2.12 Combustion gas exhaust.....	38		
2.12.1 Venting Requirements.....	39		
2.12.2 Code Required Vent Terminations.....	39		
2.12.3 Combustion Air from outside the building.....	40		
2.12.4 Combustion Air from an adjacent room.....	40		
2.12.5 Condensate Removal.....	40		
2.13 Door hinges.....	41		
2.14 Changing the direction of door opening.....	42		
2.15 Removing the hinge assembly "B".....	45		
2.16 Earth connection.....	45		
2.17 Fitting the casing panels.....	46		

The following symbols are used in this manual:

 **CAUTION!** = Identifies actions that require caution and adequate preparation.

 **STOP!** = Identifies actions that you MUST NOT do.

1 GENERAL

1.1 General safety information

⚠ Check that the product is complete, undamaged and as ordered as soon as you receive it. Report any discrepancies or damage to the **RIELLO** dealer who sold it.

⚠ The boiler must be installed by a qualified heating engineer.

UPON COMPLETION OF THE INSTALLATION THE INSTALLER MUST INSTRUCT THE OWNER AND OPERATOR ON THE FUNCTIONALITY AND THE PROPER OPERATION OF THE BOILER AND THE HEATING SYSTEM.

THIS MANUAL SHOULD BE HANDED TO THE OWNER AND OPERATOR OF THE APPLIANCE.

THE INSTALLER MUST REVIEW ALL SAFETY INSTRUCTIONS WITH THE OWNER AND OPERATOR.

The installation instructions included in this Manual are intended solely for use by a qualified installer, service agency or gas supplier. If the information in this manual is not followed exactly, a fire or explosion may result causing property damage, personal injury, or death.

- Have installation and service performed by a trained and certified installer or service company, or the gas supply company.
- **RIELLO** recommends signing a service and maintenance contract with a trained and certified installer or service company that covers annual servicing and condition-based maintenance. Proper maintenance is a fundamental requirement for safe and efficient operation and long service life.
- The boiler must be serviced annually including the burner, ignition system, the entire venting system, and the combustion air supply. All parts that show any signs of damage or corrosion must be replaced.
- The owner and operator is responsible for the operational safety and regulatory compliance of the heating system.
- Improper installation, adjustment, alteration, service, or maintenance can cause property damage, personal injury, or death. Refer to this manual and consult a trained and certified installer or service company, or the gas supply company before installation, service or maintenance.

⚠ This product must only be used for the purpose for which it is designed and made, as specified by **RIELLO**. **RIELLO** declines all responsibility, contractual or other, for damage to property or injury to persons or animals caused by improper installation, adjustment, maintenance or use.

⚠ The room where the boiler is installed must be properly ventilated to ensure a sufficient supply of air for correct combustion.

⚠ If you notice any water leaks, disconnect the boiler from the main electrical supply and shut off the water supply.

⚠ Periodically check that pressure in the central heating circuit, when cold, is approximately 20 psi (1.4 bar) and below the maximum limit specified for the boiler.

⚠ If the boiler is not going to be used for an extended period of time, perform the operations described later in this manual.

⚠ This instruction manual is an integral part of the boiler. It must be kept safe and must ALWAYS accompany the boiler, even if it is sold to another owner or transferred to another user or to another installation. If you damage or lose this manual, order a replacement immediately from your local **RIELLO** Technical Assistance Center.

1.2 General safety instructions

If you hear gas leaking

- Leave the building immediately.
- Prevent others from entering the building.
- Notify the police and fire department from outside the building.
- From outside the building, call the gas supply company and a trained and certified installer or service company.

If you smell gas

- Turn off the gas shut-off valve.
- Open windows and doors
- Do not touch any electrical switch, telephone, and do not use outlets.
- Extinguish all open flames.
- Do not smoke!
- Do not use lighters!
- Warn all occupants of the building that they need to leave the building.
- Do not ring doorbells!
- Notify the police and fire department from outside the building.
- From outside the building, call the gas supply company and a trained and certified installer or service company.

If you smell flue gas

- Switch off the appliance.
- Open windows and doors.
- Inform a trained and certified heating contractor.

⚠ DANGER: Risk of fatal injury from failing to consider your own safety!

- Never risk your own life. Your own safety must always take the highest priority.

⚠ NOTE: Risk of appliance damage from improper operation of the boiler!

- Only use the boiler for its intended purpose.
- Only operate the boiler if it has been installed and maintained per the instructions provided in the Installation Manual.
- Do not attempt to operate an appliance if any part of it is not in working order or is damaged.
- Use only original spare parts! The use of parts not supplied by the manufacturer may cause damage to the boiler, other property and personal injury. Also, boiler damage caused by the use of unauthorized parts is not covered by the warranty.

⚠ DANGER: Risk of fire when soldering and brazing!

- Take appropriate protective measures when soldering and brazing around combustible and flammable material.

⚠ NOTICE!

- The installation must comply with all applicable national, state, and local codes, rules, and regulations.
- The operator is responsible for the operational safety and regulatory compliance of the heating system.
- In the Commonwealth of Massachusetts, the appliance must be installed by a licensed plumber or gas fitter.

⚠ DANGER: Risk of personal injury or death from flue gas poisoning!

- Do not install a thermostatic flue gas damper downstream of the draft hood.
- Do not tamper with, remove, or attempt to repair the blocked vent switch.
- When replacing the blocked vent switch, install the new part in the original location.
- A blocked vent switch tripping more than once indicates a problem with the venting system or chimney which must be repaired immediately.
- Ensure none of the vent pipes and chimneys are damaged or blocked.
- Connect only one appliance to each venting system or chimney.
- The venting system must not feed into or route through another air extraction duct.
- The venting system must be inspected annually. All parts that show any signs of damage or corrosion must be replaced.
- Never close off or reduce the size of the combustion air openings.
- The boiler must not be operated until any obstructions have been removed.

⚠ DANGER: Risk of personal injury or death from explosion!

- Work on gas components may only be carried out by a trained and certified installer or service company.
- Appliance installation, the connection of gas and vent piping, initial commissioning, electrical connections and service and maintenance must only be carried out by a trained and certified installer or service company.

⚠ DANGER: Risk of personal injury or death from fire!

- Do not use flammable or combustible material in the boiler room.
- It is recommended not to store any items within 16 inches (415mm) of the appliance.

⚠ CAUTION: Appliance damage from contaminated combustion air!

- Keep the combustion air free of corrosive substances, e.g. halogenated hydrocarbons from painting operations or beauty salons.
- Keep combustion air free from dust and lint, e.g. from laundry or agricultural operations.
- If clean room air is not available, fresh outdoor combustion air must be provided.

⚠ DANGER: Risk of personal injury or death from electric shock!

- Before removing the front panel, disconnect the heating system from the electrical power supply by shutting off the emergency shutoff switch or the heating system circuit breaker.
- It is not enough to switch off the control panel. **Power to the panel must be disconnected!** Ensure that the power is not restored unintentionally by following proper lock out/tag out procedures.
- Only qualified electricians are permitted to carry out electrical work.

⚠ DANGER: Safety devices!

- Never shut off safety valves!
- Hot water may escape from the safety valve at any time when the appliance is running.

⚠ DANGER: Risk of personal injury or death after a flood!

- Do not attempt to operate an appliance if any part of it has been under water.
- An appliance that was subject to flooding must be replaced.

⚠ NOTICE!

- Upon completion of the installation, these instructions should be handed to the owner and operator of the appliance.
- The installer must instruct the owner and operator on the functionality of the components and the proper operation of the boiler and the heating system.
- The boiler must be serviced annually including the burner, ignition system and pilot, the entire venting system, and the combustion air supply. All parts that show any signs of damage or corrosion must be replaced.

1.3 Description of the appliance

RTC-80 stainless steel boilers are triple-pass, condensing boilers for installation in a boiler room. While they are designed for central heating purposes, they can also be used in conjunction with a suitable plate exchanger and storage tank to produce domestic hot water.

All parts that come into contact with the combustion gases are made from high grade stainless steel (316Ti/316L) to ensure maximum resistance to the corrosive action of acidic condensation.

The boiler has been designed with the combustion chamber at the top and the multi-pipe tube bundle (smooth pipes) at the bottom to optimize heat transfer and energy efficiency and to maximize the condensing effect.

The boiler has a high total water content allowing effective temperature stratification between its top and bottom sections. This allows outgoing water to reach the set temperature quickly while maintaining the condensing effect and maximizing the water heating dwell time around the tube bundle.

RTC-80 boilers feature a low back-pressure combustion chamber for smoother burner operation, and low backpressure waterway for reduced pump electrical consumption.

- High temperature resistant stainless steel turbulators are utilized inside the tube bundle for maximum combustion efficiency.
- The boiler body is thoroughly insulated with a layer of high density glass wool.
- The external panelling is enamel painted and internally insulated with an additional layer of high density glass wool.
- The boiler's front door and the flue gas chamber can be easily and completely opened to facilitate the inspection, maintenance and cleaning of internal parts and to speed up servicing in general.
- The hinged front door can open in either direction and can be opened without removing the burner. The door is factory fitted with hinges on the left, but these can be field-reversed if necessary to suit individual installations.

1.4 Identification

The products are identified by:

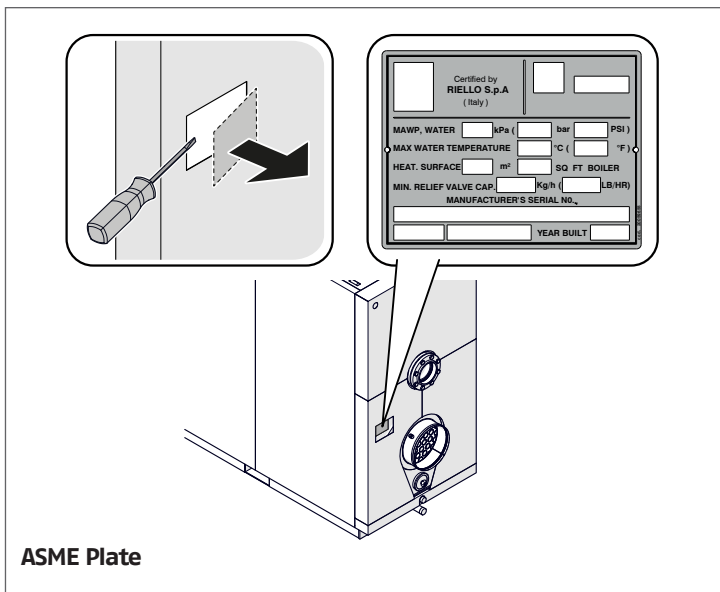

T067822EN

Certified by **RIELLO S.p.A (ITALY)**

MAWP Water	bar	kPa	psi
Maximum water temp.		°C	°F
Heating surface	m ²		SQ FT
Minimum relief valve capacity	kg/h		lb/hr
Electrical rating (burner)	Less than 12 Amperes		

SERIAL NUMBER _____

Year built: _____ Model _____

Approved for use with Natural Gas (NG), Liquid Petroleum Gas (LPG), and/or fuel oil not heavier than # 2 per ASTM D396.
Consult the Installation Manual for approved boiler and burner combinations.

Min. & Max. input oil:	Min =	gph	Max =	gph
Min. & Max. input gas:	Min =	kW /	Mbtu/hr	
	Max =	kW /	Mbtu/hr	

Design Manifold Pressure for: NG ___ "wc to ___ "wc or LP ___ "wc to ___ "wc
Inlet Pressure for: NG ___ "wc to ___ "wc or LP ___ "wc to ___ "wc

Gross output	kW	Mbtu/hr
Net IBR rating	kW	Mbtu/hr

T067822EN

MINIMUM CLEARANCES TO COMBUSTIBLE CONSTRUCTION FOR INSTALLATION ON NON COMBUSTIBLE FLOORS ONLY ALL OF THE INSTRUCTIONS MUST BE FOLLOWED EXACTLY

6" (152mm)	24" (610 mm)	18" (457mm)	18" (457mm)
ABOVE, SIDES AND REAR	FRONT	DRAFT HOOD VENT CONNECTOR	BAROMETRIC DAMPER CHIMNEY CONNECTOR

Data plate

This lists the technical specifications and performance of the product. This is supplied inside the document bag and **MUST BE APPLIED** to the boiler by the installer on completion of installation. If you damage or lose this label, order a replacement immediately from your local **RIELLO** boiler representative.

⚠ NOTE: If these plates or any other means clearly identifying the product are defaced, removed or lost, proper installation and servicing may be rendered difficult.

1.5 System layout

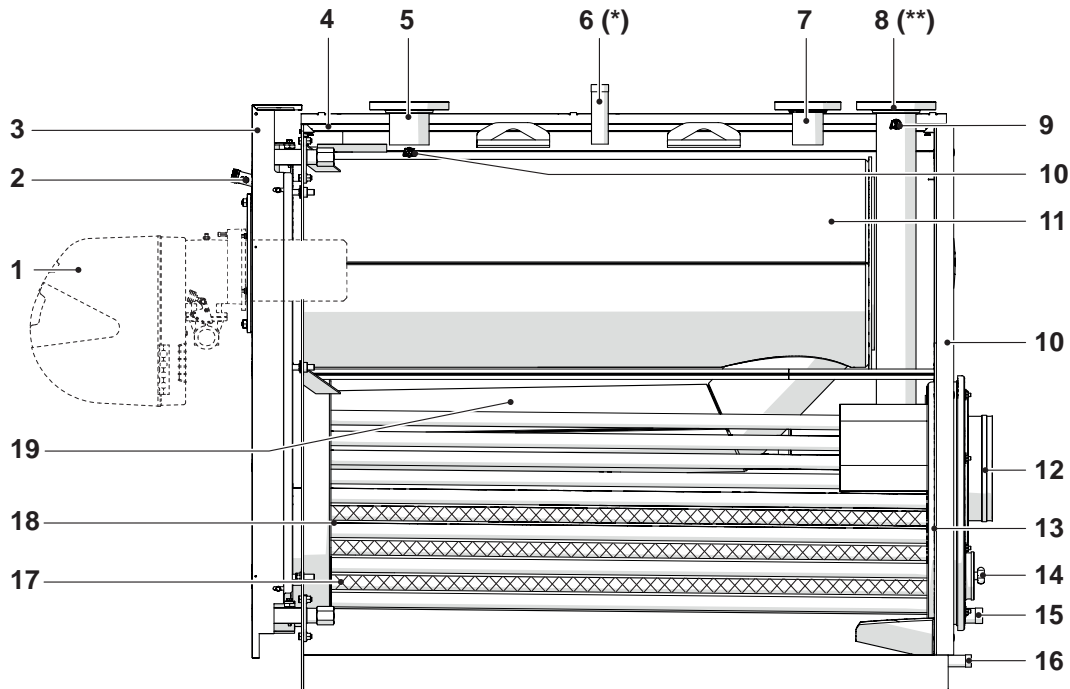

- | | | | |
|----|---|----|-------------------|
| 1 | Burner | 14 | Inspection window |
| 2 | Flame inspection window with pressure measurement point | 15 | Condensate outlet |
| 3 | Door | 16 | Boiler drain |
| 4 | Casing | 17 | Turbulators |
| 5 | Outlet | 18 | Flue gas pipes |
| 6 | Safety device fitting | 19 | Second flue pass |
| 7 | Heating return (high temperature) | | |
| 8 | Heating return (low temperature) | | |
| 9 | Blind plug | | |
| 10 | Instrument bulb/sensor sockets | | |
| 11 | Combustion chamber | | |
| 12 | Flue gas exhaust | | |
| 13 | Flue gas box | | |

(*) For models RTC 3000-5500 -80, the safety fitting (6) is flanged.

(**) For models RTC 5500 -80, the low temperature system return (8) is on the back of the boiler.

1.6 Technical specifications

1.6.1 Ratings (natural gas firing)

Description		BOILER RTC-80								
		1000	1300	1700	2300	3000	3800	4700	5500	
Minimum Input ⁽¹⁾	MBH	100	130	170	230	300	380	470	550	
	kW	29.3	38.1	49.8	67.4	87.9	111.4	137.7	161.2	
Maximum Input	MBH	1000	1300	1700	2300	3000	3800	4700	5500	
	kW	293.1	381.0	498.2	674.1	879.2	1113.7	1377.4	1611.9	
Output ⁽²⁾	Condition 1 ⁽³⁾	MBH	884	1151	1505	2036	2655	3363	4160	4868
		kW	259.1	337.3	441.1	596.7	778.1	985.6	1219.2	1426.7
	Condition 2 ⁽⁴⁾	MBH	963	1252	1638	2215	2889	3660	4526	5297
		kW	282.2	366.9	480.0	649.2	846.7	1072.6	1326.4	1552.4
Efficiency	Condition 1 ⁽³⁾	%	88.4	88.5	88.5	88.5	88.5	88.5	88.5	
	Condition 2 ⁽⁴⁾	%	96.3	96.3	96.3	96.3	96.3	96.3	96.3	
AHRI Combustion and Thermal Efficiency		%	94.0	94.0	94.0	94.0	94.0	94.0	94.0	

⁽¹⁾ Values based on natural gas firing. Based on standard burner with optional high-turndown kit.

⁽²⁾ Maximum output dependent upon application

⁽³⁾ Condition 1 based on return temperature 140°F and ΔT 36°F

⁽⁴⁾ Condition 2 based on return temperature 80°F and ΔT 36°F

1.6.2 Ratings (oil firing)

Description		BOILER RTC-80								
		1000	1300	1700	2300	3000	3800	4700	5500	
Minimum Input ⁽¹⁾	MBH	330	420	540	720	970	1210	1510	1750	
	kW	96.7	123.1	158.2	211.0	284.2	354.5	442.4	512.8	
Maximum Input	MBH	974	1270	1625	2167	2893	3619	4516	5242	
	kW	285.4	372.1	476.1	634.9	847.6	1060.4	1323.2	1535.9	
Output ⁽²⁾	Condition 1 ⁽³⁾	MBH	902	1177	1506	2009	2682	3355	4186	4859
		kW	264.3	344.9	441.3	588.6	785.8	983.0	1226.5	1423.7
Efficiency	Condition 1 ⁽³⁾	%	92.6	92.7	92.7	92.7	92.7	92.7	92.7	

⁽¹⁾ Values based on oil firing

⁽²⁾ Maximum output dependent upon application

⁽³⁾ Condition 1 based on return temperature 140°F and ΔT 36°F

1.6.3 Specifications

Description	BOILER RTC-80							
	1000	1300	1700	2300	3000	3800	4700	5500
Boiler category	ASME Section IV							
Maximum allowable working pressure	80 psi	80 psi	80 psi	80 psi	80 psi	80 psi	80 psi	80 psi
Maximum allowable working temperature	210°F	210°F	210°F	210°F	210°F	210°F	210°F	210°F
Water Connections Inlet/Outlet (Flanged)	2-1/2"	3"	4"	4"	5"	5"	6"	6"
High Temp. Return Water Connections	2"	2-1/2"	3"	3"	3"	3"	4"	4"
Minimum Water Flow (GPM) (*)	12	15	20	30	40	50	60	70
Maximum Water Flow (GPM) (*)	130	160	200	290	370	480	580	690
Water Volume (Gal) (*)	130.7	146.6	196.2	203.4	348.7	368.5	482.1	501.9
Water Pressure Drop	0.67 psi at 95 GPM (*)	0.49 psi at 124 GPM (*)	0.44 psi at 162 GPM (*)	1.86 psi at 219 GPM (*)	1.76 psi at 285 GPM (*)	1.36 psi at 361 GPM (*)	1.45 psi at 447 GPM (*)	2.18 psi at 523 GPM (*)
Static pressure at the flue	max (positive)							
	min. (negative)							
	0.2" W.C.							
	-0.1" W.C.							
Maximum turndown (Nat.Gas)	10:1	10:1	10:1	10:1	10:1	10:1	10:1	10:1
Vent Connections	10"	10"	12"	12"	14"	14"	16"	18"
Vent Materials	AISI 316L AL29-4C (29% Cr - 4% Mo)							
Type of Fuel (**)	Natural Gas, Propane, #2 Fuel Oil (***)							
NOx Emissions <30ppm Capability on Nat. Gas	yes							
Temperature Control Range	80°F to 195°F							
Ambient Temperature Range	32°F to 140°F							
Standard Listings & Approvals	ASME, ETL, AHRI							
Water capacity (Gal) (*)	130.7	146.6	196.2	203.4	348.7	368.5	482.1	501.9
Weight (dry) lbs. (without paneling)	1676	1786	2679	2965	4167	4777	5908	6834
Shipping Weight lbs. (without paneling)	1720	1841	2756	3097	4334	4956	6085	7028
Weight of paneling lbs.	132	154	198	264	308	352	473	506
Weight (wet) lbs. (with paneling)	2899	3164	4515	4927	7385	8206	10406	11530

(*) Units shown are in US Gallons.

(**) Other fuels may be used. For alternate fuels not listed, please contact factory.

(***) Using #2 Fuel Oil, the boiler return temperature must not be lower than 140 °F (non-condensing operation).

1.7 Intended use

This boiler must only be used for the purpose specified by the manufacturer and for which it is designed.

The **RTC-80** can be operated with gas, oil, and combination burners. For a list of the approved burners, see specific paragraph in this manual.

A variety of alternate fuels such as biodiesel, jet fuel, etc may also be utilized (contact **RIELLO** engineering for applicability).

The boiler can be operated with an aquastat and other control systems.

The manufacturer declines all responsibility, contractual or other, for damage to property or injury to persons or animals caused by improper installation, adjustment, maintenance or use.

1.8 Certification and test mark

This appliance has been tested and certified and meets all applicable standards for the US markets:

- UL 296 Standard for oil burners
- UL 726 Standard for oil-fired boiler assemblies
- UL 795 Standard for commercial industrial gas heating equipment.

And for Canadian market:

- UL 726 Issued: 1995/11/30 Ed: 7 Rev: 2013/10/09 Oil-Fired Boiler Assemblies
- UL 795 Issued: 2011/04/06 Ed: 7 Rev: 2013/11/27 Commercial-Industrial Gas Heating Equipment
- Industrial And Commercial Gas-Fired Package Boilers (R2016) [CGA 3.1:1977 +A1:13;U14]
- Oil-Burning Equipment: General Requirements (R2013) [CSA B140.0:2003 Ed.3]
- Oil-Burning Equipment: Steam And Hot-Water Boilers (R2014) [CSA B140.7:2005 Ed.2]

1.9 Regulations and guidelines

1.9.1 National regulation

The heating system must comply with the requirements of the relevant regulatory authorities or otherwise of the National Fuel Gas Code, ANSI Z 223.1.

If specified by the relevant regulatory authorities, the heating system must comply with the regulations of the Standard for Controls and Safety Devices for Automatically Fired Boilers, ANSI/ASME CSD-1. Carbon monoxide detectors must be installed as specified by the local regulations. The boiler must be serviced annually.

1.9.2 Compliance with standards and regulations

Installation of the boiler must comply with all applicable codes and regulations imposed by the national, federal or local authorities and bodies. If no specific requirements are defined, in the USA, the boiler must comply with the latest edition of the National Fuel Gas Code ANSI Z223.1/NFPA 54.

Where required by local regulations, the system must comply with the American Society of Mechanical Engineers Safety Code for Controls and Safety Devices for Automatically Fired Boilers (ASME CSD-1).

⚠ WARNING: Risk of fatal injury from explosion of flammable gases.

- Installation, connection of the fuel supply and flue pipe, commissioning, connection of the electrical power supply, servicing and repair may only be carried out by an authorized heating engineer.
- Any work on gas piping components may only be carried out by an authorized gas installer.

The local regulations regarding minimum pressure detectors, maximum relief valves and low water safety cutouts must be observed. Installation and operation must comply with the device manufacturer's technical documentation.

We recommend fitting an 80 mesh dirt filter externally to the boiler return to prevent contamination of the boiler by the water source.

Leak test

A leak test must be carried out on the hydronic heating system. The testing pressure is based on the normal operating pressure of the heating system and should be 1.3 times that pressure, and in any case no less than 14 psi (1 bar).

Safety limits	Value
Maximum allowable temperature:	210 °F (99 °C)
Maximum Allowable Working Pressure (MAWP)	550 kPa (80 psi)
Maximum cycle time for safety temperature limiter:	40 s
Maximum cycle time for temperature control:	40 s

1.9.3 Additional regulations for installations in the Commonwealth of Massachusetts

a) For all side wall horizontally vented gas fueled equipment installed in every dwelling, building or structure used in whole or in part for residential purposes, including those owned or operated by the Commonwealth and where the side wall exhaust vent termination is less than seven (7) feet above finished grade in the area of the venting, including but not limited to decks and porches, the following requirements shall be satisfied:

INSTALLATION OF CARBON MONOXIDE DETECTORS: At the time of installation of the side wall horizontal vented gas fueled equipment, the installing plumber or gasfitter shall observe that a hard wired carbon monoxide detector with an alarm and battery back-up is installed on the floor level where the gas equipment is to be installed. In addition, the installing plumber or gasfitter shall observe that a battery operated or hard wired carbon monoxide detector with an alarm is installed on each additional level of the dwelling, building or structure served by the side wall horizontal vented gas fueled equipment. It shall be the responsibility of the property owner to secure the services of qualified licensed professionals for the installation of hard wired carbon monoxide detectors.

- In the event that the side wall horizontally vented gas fueled equipment is installed in a crawl space or an attic, the hard wired carbon monoxide detector with alarm and battery back-up may be installed on the next adjacent floor level.
- In the event that the requirements of this subdivision cannot be met at the time of completion of installation, the owner shall have a period of thirty (30) days to comply with the above requirements; provided, however, that during said thirty (30) day period, a battery operated carbon monoxide detector with an alarm shall be installed.

APPROVED CARBON MONOXIDE DETECTORS: Each carbon monoxide detector as required in accordance with the above provisions shall comply with NFPA 720 and be ANSI/UL 2034 listed and IAS certified.

SIGNAGE: A metal or plastic identification plate shall be permanently mounted to the exterior of the building at a minimum height of eight (8) feet above grade directly in line with the exhaust vent terminal for the horizontally vented gas fueled heating appliance or equipment.
The sign shall read, in print size no less than one-half (1/2) inch in size, "GAS VENT DIRECTLY BELOW. KEEP CLEAR OF ALL OBSTRUCTIONS".

INSPECTION: The state or local gas inspector of the side wall horizontally vented gas fueled equipment shall not approve the installation unless, upon inspections, the inspector observes carbon monoxide detectors and signage installed in accordance with the provisions of 248 CRM 5.08(2)(a) 1 through 4.

b) EXEMPTIONS: The following equipment is exempt from 248 CRM 5.08(2)(a) 1 through 4:

- The equipment listed in Section 10 entitled "Equipment Not Required To Be Vented" in the most current edition of NFPA 54 as adopted by the board;
- Product Approved side wall horizontally vented gas fueled equipment installed in a room or structure separate from the dwelling, building or structure used in whole or in part for residential purposes.

c) MANUFACTURERS REQUIREMENTS – GAS EQUIPMENT VENTING SYSTEM REQUIRED: When the manufacturer of Product Approved side wall horizontally mounted gas equipment provides a venting system design or venting system components with the equipment, the instructions provided by the manufacturer for the installation of the equipment and venting shall include:

- Detailed instructions for the installation of the venting system or the venting system components;
- A complete parts list for the venting system design or venting system.

d) MANUFACTURERS REQUIREMENTS – GAS EQUIPMENT VENTING SYSTEM NOT PROVIDED: When the manufacturer of Product Approved side wall horizontally vented gas fueled equipment does not provide the parts for the venting of flue gases, but identifies "special venting systems", the following requirements shall be satisfied by the manufacturer:

- The referenced "special venting systems" shall be included with the appliance or equipment installation instructions;
- The "special venting systems" shall be Product Approved by the Board and the instructions for that system shall include a parts list and detailed installation instructions.

e) A copy of all instructions for all Product Approved side wall horizontally vented gas fueled equipment, all venting instructions, all parts lists for venting instructions and/or venting design instructions shall remain with the appliance or equipment at the completion of the installation.

1.10 Suitable fuels

Permissible fuels

- Natural gas from the public gas supply in accordance with national regulations with a total sulphur content < 15ppm.
- LP in accordance with national regulations with a content of elementary sulphur < 1.5 ppm and volatile sulphur < 50 ppm.
- Ultra Low Sulphur Diesel in accordance with national regulations with a content of elementary sulphur < 15 ppm (for use as back-up fuel in condensing operation).
- Heating oil type 2 when boiler return temperature is not lower than 140 °F; non-condensing operation. See the warranty statement for additional details.
- A variety of alternate fuels such as biodiesel, jet fuel A, etc may also be utilized. Contact **RIELLO** for applicability.

- ⚠** Do not use gasoline, crankcase drainings, or any oil containing gasoline.
- The boiler must only be operated with the specified fuels.
 - Only burners that are suitable for the specified fuels may be used.
 - Observe the manufacturer's burner selection list and the burner manufacturer's instructions.

1.11 Burners

Follow the burner manufacturer's instructions when fitting the burner. A pre-drilled burner plate is included with the boiler. An adapter plate may be required if a non-standard burner is used (see table).

As standard, the burner plate gasket must be trimmed in order to fit the burner blast tube.

The installer must cut the hole 3/8" larger than the blast tube diameter.

The combustion chamber door must be opened to allow the burner to be mounted.

If the burner head is too long to open/close the combustion chamber door, the burner will have to be removed prior to the opening/closing of the door.

For reduction of burner capacity according to altitude make reference to the burner manual.

- ⚠** After the burner is installed, fill the gap between the burner tube and the refractory material in the door with the ceramic insulation supplied loose with the boiler.

		BOILER RTC-80			
		1000	1300	1700	2300
Fireside pressure drop	inch W.C.	1.284	1.846	2.007	2.208
	mbar	3.2	4.6	5.0	5.5

		BOILER RTC-80			
		3000	3800	4700	5500
Fireside pressure drop	inch W.C.	2.288	2.529	2.729	2.970
	mbar	5.7	6.3	6.8	7.4

At maximum output with water temps supply/return of 176/140 °F (80/60 °C), CO₂=9.7% and O₂=3.6%.

1.11.1 Recommended burners and burner plate accessories kit

The following table shows the ordering codes for the burner mounting plate kits.

BURNERS MODEL	BOILER RTC-80							
	1000	1300	1700	2300	3000	3800	4700	5500
GAS								
RS28/M	x							
RS28/E	x							
RS38/M	●	x ●						
RS38/E	●	x ●						
RS45/M LN	x ●	x ●	x					
RS45/E LN	x ●	x ●	x					
RS50/M			x					
RS50/E			x					
RS68/M LN			● 20176959	x ● 20176959				
RS68/E LN			● 20184650	x ●				
RS70/M			● 20184650	x ●				
RS 70/E			● 20184650	x ●				
RS 100/M					x ●	x		
RS 100/E					x ●	x		
RS 120/M LN					x ● 20185273	x ● 20185273		
RS 120/E LN					x ●	x		
RS 130/M						x ●	x	
RS 130/E						●	x	
RS 160/M LN						x ●	x ●	x ●
RS 160/E LN						x ●	x ●	x ●
RS 190/M							●	x ●
RS 190/E							●	x ●

- (x) 0 feet altitude
 (●) 6000 feet altitude
 (*) Sliding

Burners are approved to UL Standard UL 295 and CSA Standard CGA 3.4 Riello file number MP 3252

-  See the instruction manual provided with the burner:
- Burner installation
 - Electrical connections
 - Burner adjustments

BURNERS	BOILER RTC-80								
	MODEL	1000	1300	1700	2300	3000	3800	4700	5500
MIXED OIL/GAS									
RLS 28	x								
RLS28/E	x								
RLS 38	•	x							
RLS38/E		x							
RLS 50		•	x						
RLS 50/E			x						
RLS 70			• 20176959	• 20176959					
RLS 68/E			• 20184650	•					
RLS 100					x • 20185273	x 20185273			
RLS 130						• 20185273	• 20185273		
RLS 160/E							x •	x •	
RLS 190							•	x •	
RLS 190/E							•	x •	
PREMIX									
RX 400	20067543 (*)								
RX 500		20067543 (*)	x 20067544 (30/20 ppm)						
RX 700			• 20169559 (20-9 ppm)	• 20169559 (30 ppm)					
RX 850				• 20169559 (20-9 ppm)	• 20169560 (30 ppm)				
RX1000					• 20169560 (20-9 ppm)	• 20169560 (30/20 ppm)			
RX1500							x 20124397 (30/20/9 ppm)	x 20124397 (30 ppm)	
RX1800									x 20124397 (20/9 ppm)

- (x) 0 feet altitude
(•) 6000 feet altitude
(*) Sliding

Burners are approved to UL Standard UL 295 and CSA Standard CGA 3.4 Riello file number MP 3252

 See the instruction manual provided with the burner:

- Burner installation
- Electrical connections
- Burner adjustments

2 INSTALLATION

2.1 Unpacking the product

RTC-80 boilers are delivered in two separate packs.

The first contains:

- the boiler body inside a protective bag (A);
- flue cleaning brush (B);
- ceramic insulation (C) (within combustion chamber);
- fiberglass braid (20x15) (D) (within combustion chamber);
- documentation envelope (E) containing:
 - instruction manual
 - Copy of H-2 Form
 - data label and warning label (to be applied to the casing on completion of the installation)
 - water treatment instructions

⚠ DO NOT START THE BOILER UNTIL THE OPERATIONS INDICATED ON THE RED LABEL ON THE FLAME VIEWER HAVE BEEN CARRIED OUT.

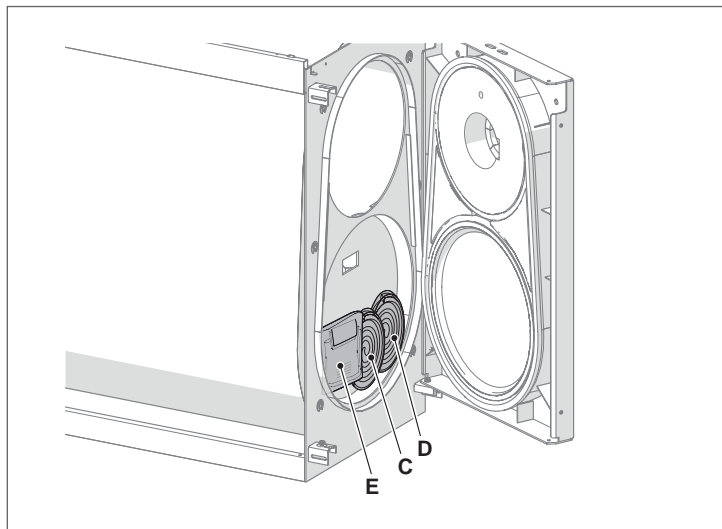
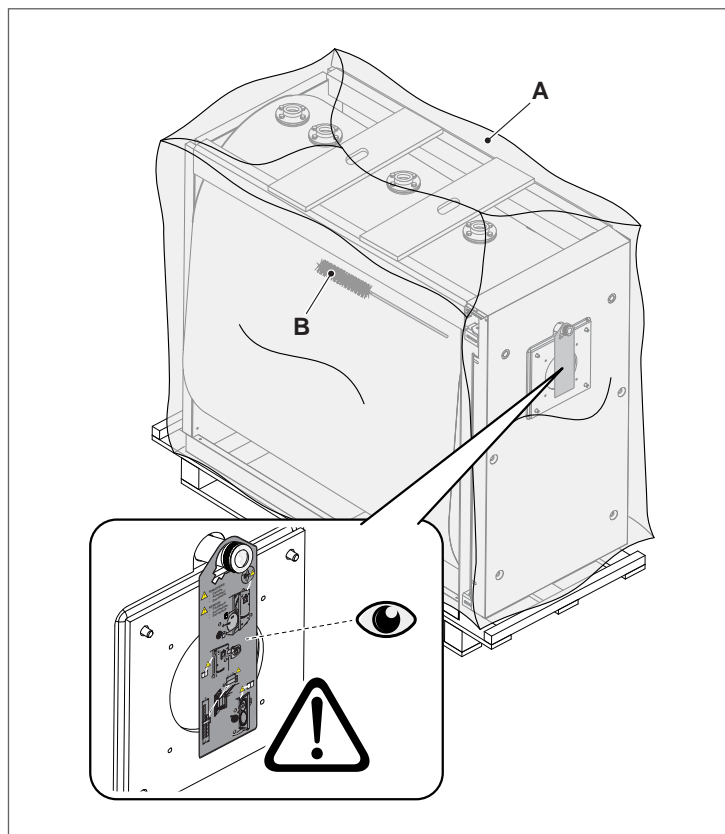

The second contains:

- the boiler casing complete with installation accessories, protected by cardboard packing and a wooden crate.

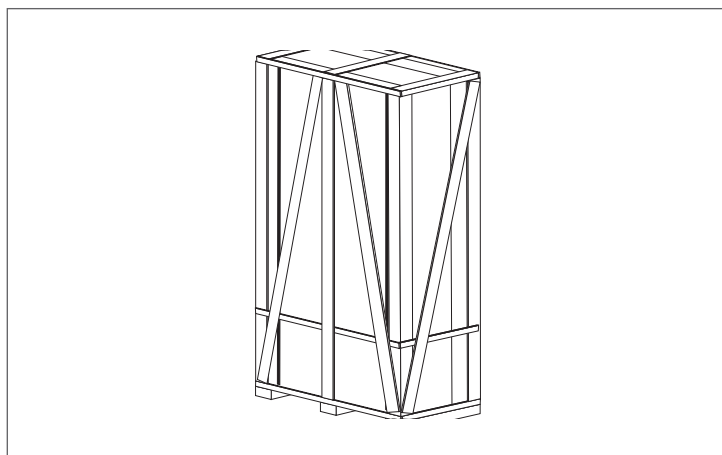

⚠ NOTE: The instruction manual is an integral part of the appliance; therefore, it should be read and stored carefully.

⚠ NOTE: Keep the documentation envelope in a safe place. Any replacement documents must be ordered from Riello S.p.A. who reserve the right to charge for the cost of the replacement.

2.2 Overall dimensions and weights

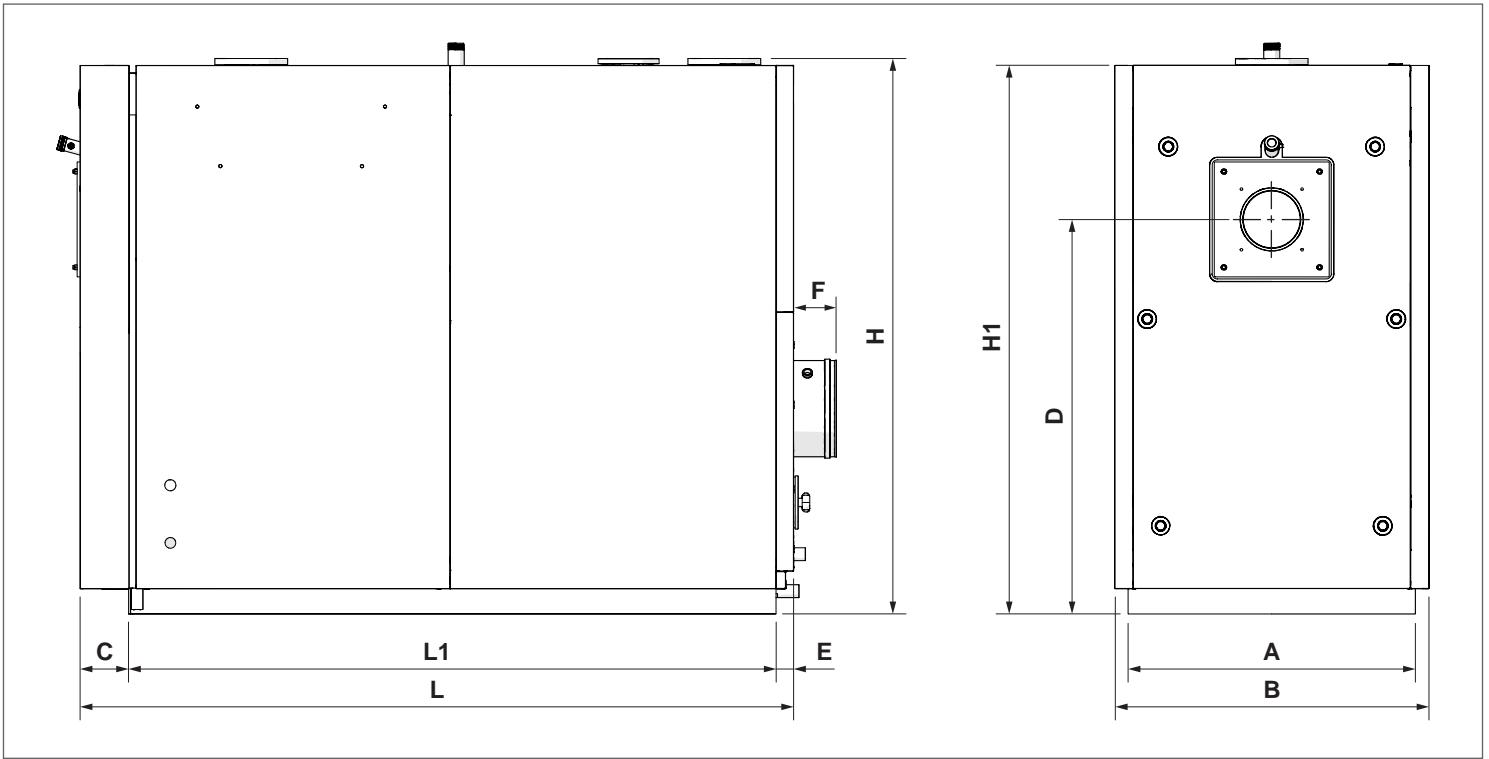

Description		Unit	BOILER RTC-80							
			1000	1300	1700	2300	3000	3800	4700	5500
A	Base width	inch	29 1/2	29 1/2	31 1/8	31 1/8	38 9/16	38 9/16	42 1/8	44 1/2
		mm	750	750	790	790	980	980	1070	1130
B	Overall width	inch	32 5/16	32 5/16	35 1/16	35 1/16	42 1/2	42 1/2	46 1/16	48 1/4
		mm	820	820	890	890	1080	1080	1170	1225
C	Length base to front	inch	4 15/16	4 15/16	5 1/8	5 1/8	5 1/2	5 1/2	6 1/8	5 7/8
		mm	125	125	130	130	140	140	155	150
D	Height of burner plate	inch	40 9/16	40 9/16	48 5/8	48 5/8	54 3/4	54 3/4	58 7/8	62 5/8
		mm	1030	1030	1235	1235	1390	1390	1495	1590
E	Length base to rear	inch	1 9/16	1 9/16	1 3/8	1 3/8	2 3/4	2 3/4	3 1/8	3 15/16
		mm	40	40	35	35	70	70	80	100
F	Flue connection depth	inch	4 21/64	4 21/64	5 1/8	5 1/8	5 1/2	5 1/2	5 1/8	5 1/8
		mm	110	110	130	130	140	140	130	130
H	Height of water fittings	inch	57 1/16	57 1/16	66 3/4	66 3/4	75	75	80 5/16	85 13/16
		mm	1450	1450	1695	1695	1905	1905	2040	2180
H1	Boiler height	inch	56 9/16	56 9/16	66 1/8	66 1/8	74 7/16	74 7/16	79 3/4	85 1/4
		mm	1435	1435	1680	1680	1890	1890	2025	2165
L	Length	inch	65 3/16	73 1/16	80 1/8	88	103 1/8	113	120 11/16	121 1/4
		mm	1655	1855	2035	2235	2620	2870	3065	3080
L1	Base length	inch	58 11/16	66 9/16	73 7/16	81 1/2	94 7/8	104 3/4	111 7/16	111 7/16
		mm	1490	1690	1865	2070	2410	2660	2830	2830
Weight of boiler	lbs	1676	1786	2679	2965	4167	4777	5908	6834	
	kg	760	810	1215	1345	1890	2167	2680	3100	
Weight of paneling	lbs	132	154	198	264	308	352	473	506	
	kg	60	70	90	120	140	160	215	230	

2.3 Moving and removing the packaging

⚠ Wear suitable personal protection equipment when moving the boiler and removing the packing. Only use lifting equipment that is suitable for the weight involved.

The product can be moved in two ways:

- using a hoist of suitable lifting capacity;
- using a fork lift of suitable lifting capacity.

Two lifting points (A) are provided at the top of the boiler body for use with a hoist.

⚠ Move the boiler to its place of installation, using equipment of suitable lifting capacity.

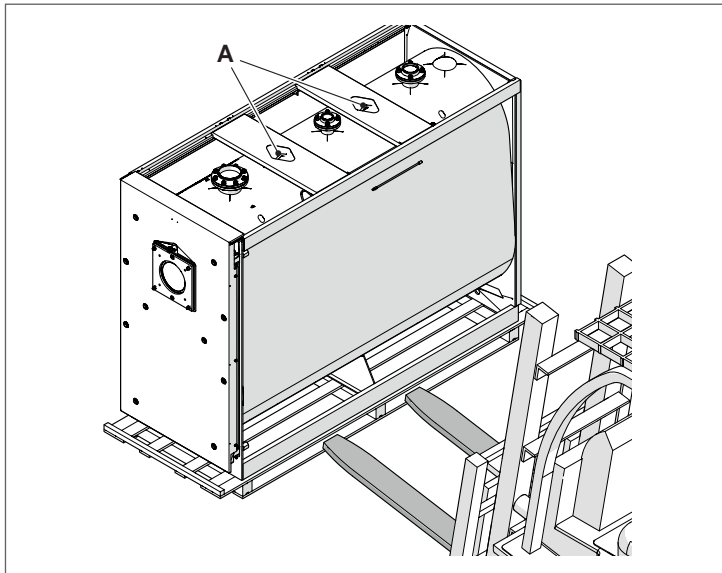

⚠ **CAUTION:** Do not dispose of packaging material into the environment, or leave it within the reach of children, since it can become a potential hazard. Dispose of packaging material in compliance with the applicable legislation.

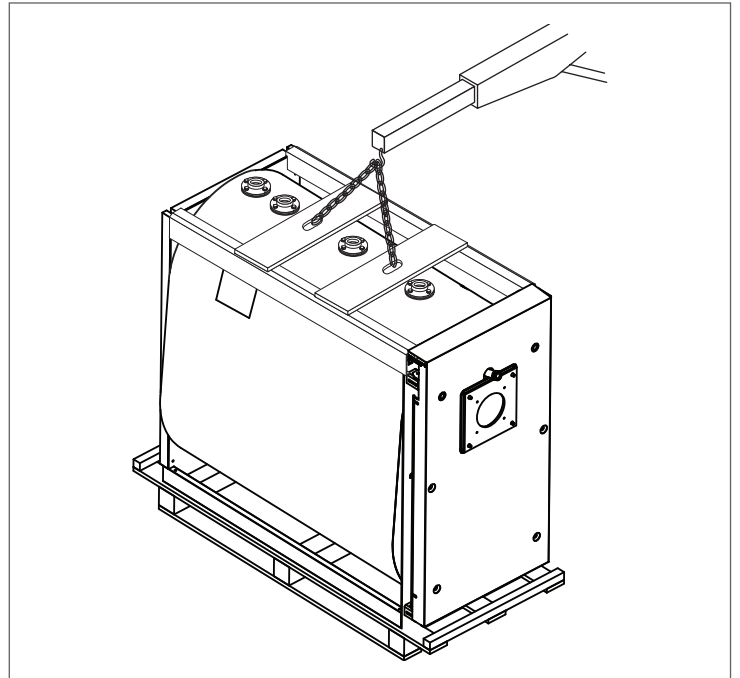

- for lifting using a rigging crane, use only the lifting provisions supplied.
- when lifting the boiler using chains, make sure that at least two chains are load-bearing. Lift up very carefully.
- maintain less than a 45 degree angle with the vertical when lifting the boiler with chains or cables.
- the rigging crane must be operated by trained personnel.

⚠ **WARNING:** Risk of injury from carrying heavy loads and inadequately securing loads for transport.

- Use suitable means of transportation, e.g. several pallet trucks, a forklift truck, crane or heavy duty rollers
- secure the load against falling.

2.4 Installation premises

RTC-80 boilers must be installed in a dedicated boiler room that conforms to applicable laws and standards. The boiler room must have adequately sized vents that also conform to applicable laws and standards.

Ambient temperature must be between 32°F and 140°F (0°C and 60°C).

All boiler models must be installed at a height of at least 4" from the floor to permit the necessary pipes and valves to be connected to the boiler drain and condensate drain.

If possible, the boiler should be installed on a raised base to prevent the burner fan from drawing in dust and to facilitate draining of condensate to a neutralization system. The boiler base must be flat and levelled.

The boiler condensate drain must be located above the height of the lid of the system's condensate neutralizer.

The gas supply pipe should be installed in such a way that the boiler's paneling can be removed and the front door opened without having to remove the burner.

⚠ WARNING: When installing the boiler, allow sufficient space around it to access all safety and control devices and to permit easy maintenance.

⚠ WARNING: Check that the electric protection level of the appliance is suitable for features of the room where it is installed.

⚠ WARNING: Make sure that combustion air is not contaminated by substances containing chlorine or fluorine (elements found in sprays, paints, detergents etc.).

⊖ These boilers must be installed indoors. They are not designed for outside use.

⊖ WARNING: Do not obstruct or restrict the air vents in the room where the boiler is installed. A free air supply is essential for correct combustion.

2.4.1 Installation clearances

Single Boiler configuration

This figure shows suggested installation clearances. If necessary, the boilers may be mounted side by side with reduced clearance between. Top clearance may also be reduced depending on the mounting positions of accessories such as temperature sensors and relief valve.

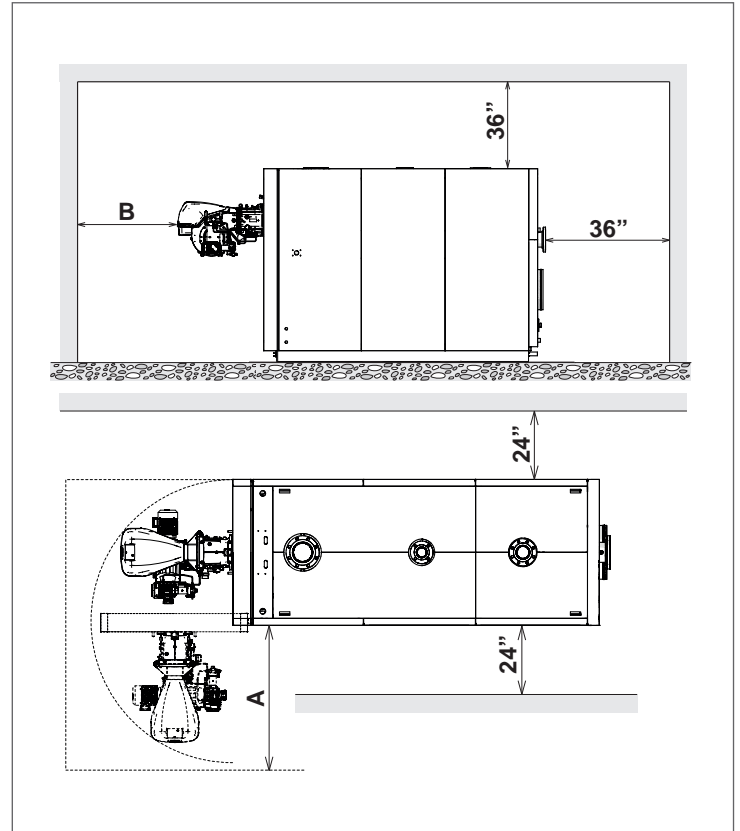

BOILER RTC-80	Minimum distances		Unit
	A	B	
1000	32	25	inch
1300	32	28	inch
1700	40	28	inch
2300	40	28	inch
3000	48	28	inch
3800	48	36	inch
4700	48	36	inch
5500	48	40	inch

Two-Boilers configuration

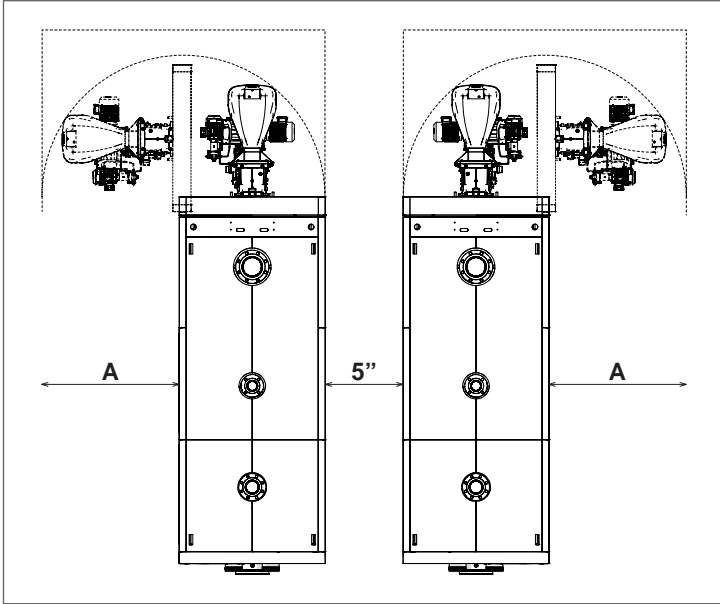

Three-Boilers configuration

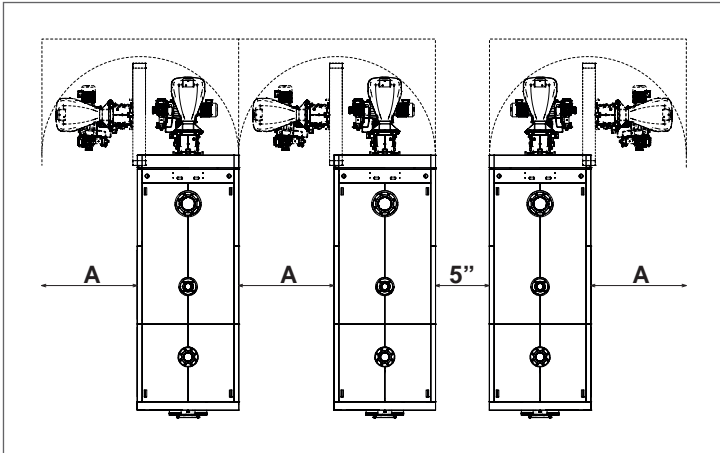

Four-Boilers configuration

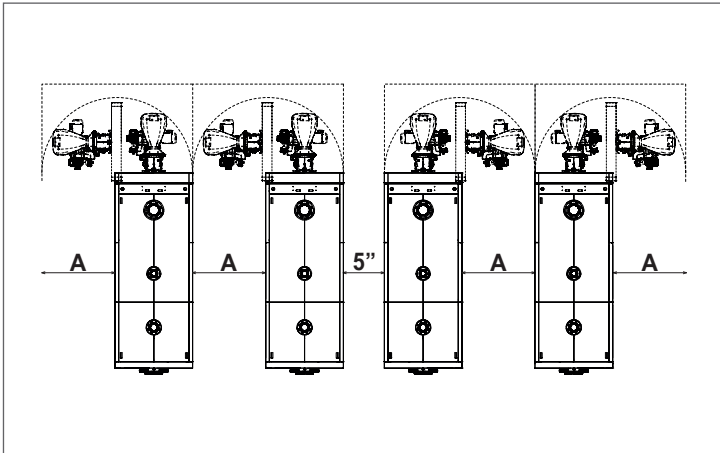

BOILER RTC-80	A Minimum distances	Unit
1000	32	inch
1300	32	inch
1700	40	inch
2300	40	inch
3000	48	inch
3800	48	inch
4700	48	inch
5500	48	inch

⚠ WARNING: Make sure that the door is properly oriented.

2.4.2 Minimum clearance to combustibles

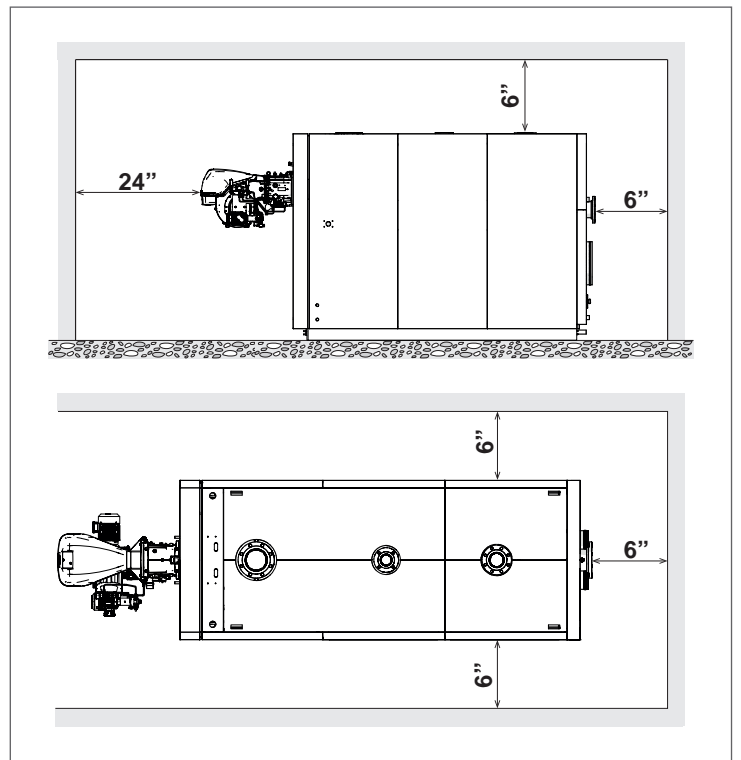

2.5 Water connections

The following table gives the dimensions and positions of the water fittings on **RTC-80** boilers. Before installing the boiler, flush out all the pipes of the central heating circuit to remove any machining residues, oils, scale, dirt and debris.

Models RTC 1000-4700 -80

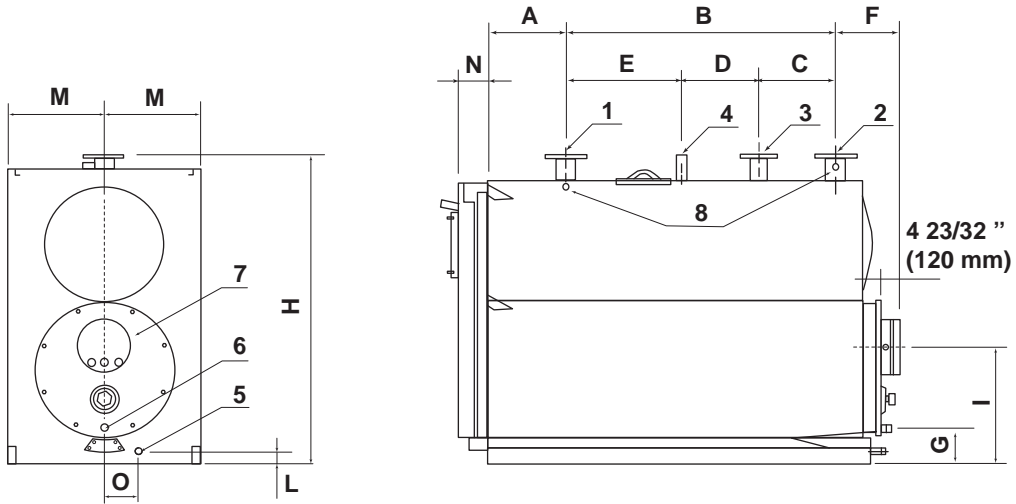

Model RTC 5500 -80

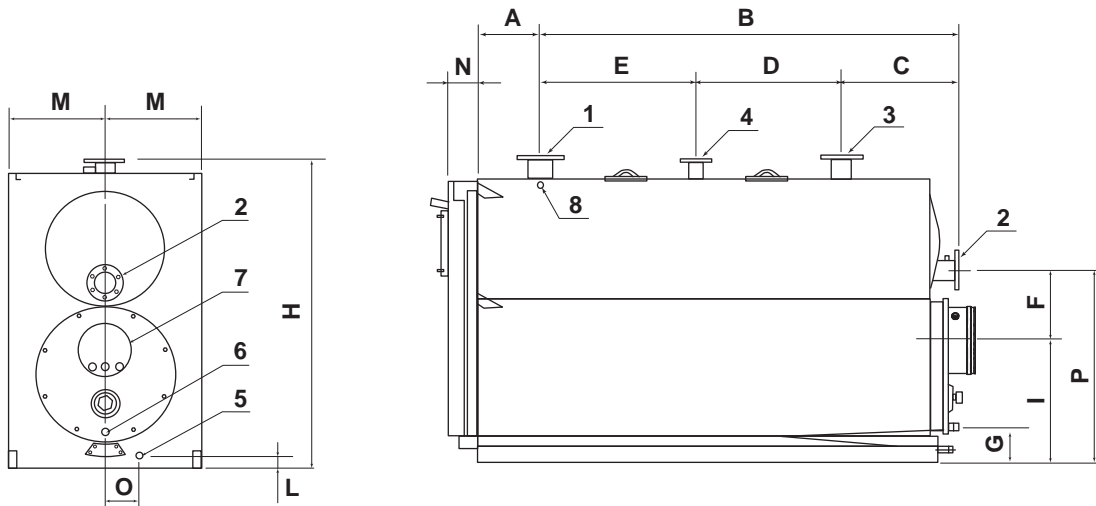

Description		Unit	BOILER RTC-80							
			1000	1300	1700	2300	3000	3800	4700	5500
1	Heating supply	NPS	2-1/2" #150	3" #150	4" #150	4" #150	5" #150	5" #150	6" #150	6" #150
2	Heating return 1 (Low Temperature)	NPS	2-1/2" #150	3" #150	4" #150	4" #150	5" #150	5" #150	6" #150	6" #150
3	Heating return 2 (High Temperature)	NPS	2" #150	2-1/2" #150	3" #150	3" #150	3" #150	3" #150	4" #150	4" #150
4	Safety device fitting	inch - NPS	1 1/4	1 1/4	1 1/2	1 1/2	3" #150	3" #150	3" #150	3" #150
5	Boiler drain fitting	∅ inch	1	1	1	1	1 1/4	1 1/4	1 1/4	1 1/4
6	Condensate drain fitting	∅ inch	1	1	1 1/4	1 1/4	1 1/4	1 1/4	1 1/4	1 1/4
7	Flue gas exhaust fitting	∅ mm	250	250	300	300	350	350	400	450
8	Instrument bulb/probe sockets	n° x ∅ "	3 x 1/2	3 x 1/2	3 x 1/2	3 x 1/2	3 x 1/2	3 x 1/2	3 x 1/2	3 x 1/2
A	Distance from boiler front to supply outlet	inch (mm)	12 1/16 (306)	12 5/8 (321)	12 1/4 (311)	12 1/4 (311)	16 1/8 (410)	16 1/8 (410)	17 5/16 (440)	17 3/8 (442)
B	Distance from heating flow outlet to return 1	inch (mm)	41 3/8 (1050)	48 5/8 (1235)	55 5/16 (1405)	63 3/16 (1605)	70 7/8 (1800)	80 11/16 (2050)	86 5/8 (2200)	101 5/8 (2582)
C	Distance between heating returns 1 & 2	inch (mm)	11 13/16 (300)	9 7/8 (250)	10 1/8 (255)	11 13/16 (300)	13 13/16 (350)	13 13/16 (350)	13 13/16 (350)	28 13/16 (732)
D	Distance between heating return 2 and safety device fitting	inch (mm)	11 13/16 (300)	17 3/4 (450)	23 5/8 (600)	27 9/16 (700)	29 1/2 (750)	33 1/2 (850)	33 1/2 (850)	33 1/2 (850)
E	Distance between heating flow outlet and safety device fitting	inch (mm)	17 3/4 (450)	21 1/16 (535)	21 11/16 (550)	23 13/16 (605)	27 9/16 (700)	33 1/2 (850)	39 3/8 (1000)	39 3/8 (1000)
F	Distance between heating return 1 and flue gas outlet	inch (mm)	11 13/32 (290)	11 13/32 (290)	12 19/32 (320)	12 19/32 (320)	14 3/4 (375)	14 3/4 (375)	15 47/64 (400)	24 13/64 (615)
G	Height of condensate drain	inch (mm)	6 1/8 (155)	6 1/8 (155)	8 1/2 (215)	8 1/2 (215)	7 11/16 (195)	7 11/16 (195)	8 7/16 (215)	9 1/4 (235)
H	Height of boiler flanges	inch (mm)	57 1/16 (1450)	57 1/16 (1450)	66 3/4 (1695)	66 3/4 (1695)	75 (1905)	75 (1905)	80 5/16 (2040)	85 13/16 (2180)
I	Height of flue gas outlet	inch (mm)	21 1/16 (535)	21 1/16 (535)	25 (635)	25 (635)	26 3/4 (680)	26 3/4 (680)	28 1/32 (712)	31 11/16 (805)
L	Height of boiler drain fitting	inch (mm)	2 13/32 (61)	2 13/32 (61)	3 1/4 (82)	3 1/4 (82)	3 3/8 (86)	3 3/8 (86)	3 1/2 (90)	3 3/8 (85)
M	Boiler centerline	inch (mm)	14 3/4 (375)	14 3/4 (375)	15 9/16 (395)	15 9/16 (395)	19 5/16 (490)	19 5/16 (490)	21 1/16 (535)	22 1/4 (565)
O	Distance from Boiler drain fitting	inch (mm)	5 3/8 (137)	5 3/8 (137)	4 15/16 (125)	4 15/16 (125)	6 7/8 (175)	6 7/8 (175)	7 1/8 (181)	7 (178)
P	Height of heating return 1 (Low Temperature)	inch (mm)	-	-	-	-	-	-	-	53 7/8 (1370)

Flange as for ASME B16.5

2.6 Sensor manifold installation

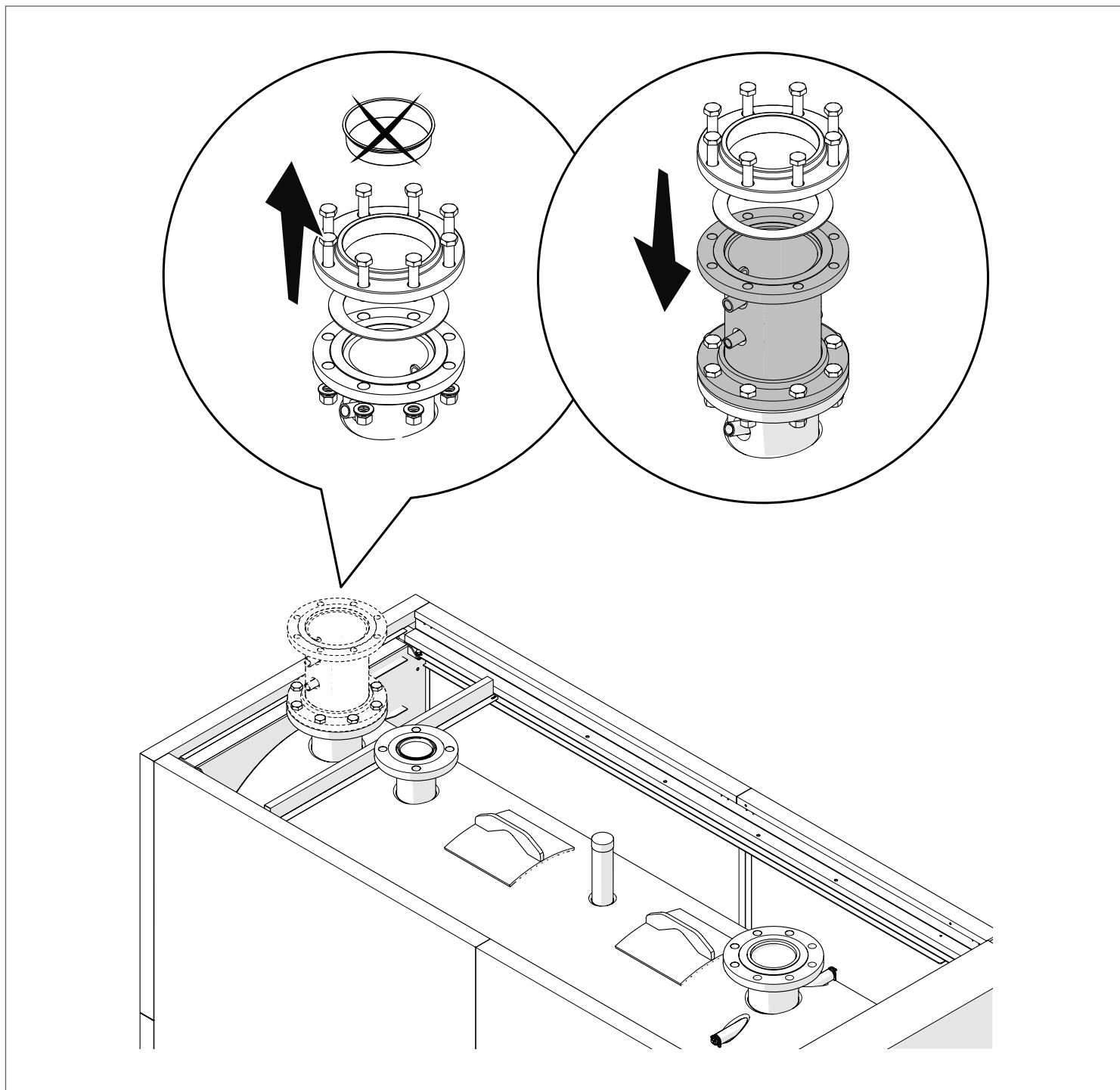

	BOILER RTC-80								Ø NPS
	1000	1300	1700	2300	3000	3800	4700	5500	
Sensor manifold type	2-1/2" #150	3" #150	4" #150		5" #150		6" #150		

2.7 Sensor manifold connections

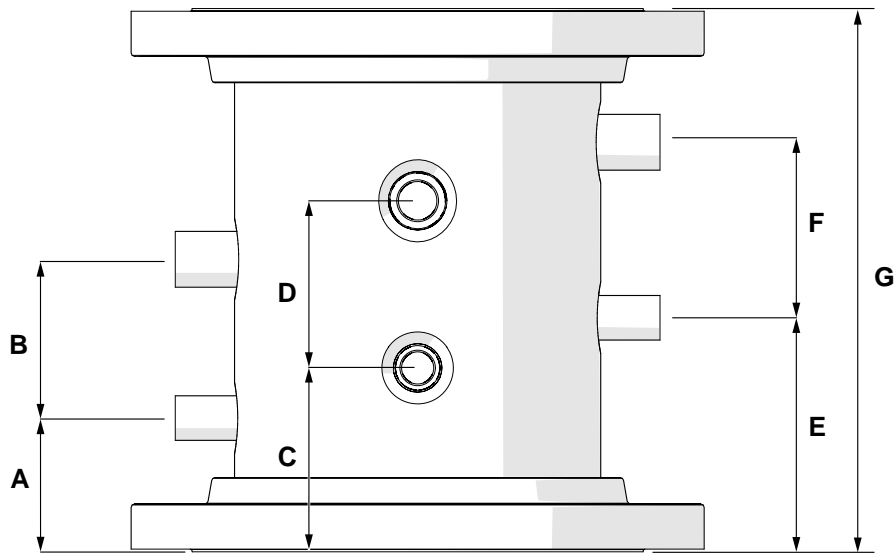

Sensor manifold type	2-1/2" #150	3" #150	4"#150	5" #150	6"#150
A	3-17/64" 83 mm	3-17/64" 83 mm	3-5/32" 80 mm	3-5/32" 80 mm	3-5/32" 80 mm
B	3-15/16" 100 mm	3-15/16" 100 mm	3-47/64" 95 mm	3-47/64" 95 mm	3-47/64" 95 mm
C	4-29/64" 113 mm	4-1/4" 108 mm	4-21/64" 110 mm	4-21/64" 110 mm	4-21/64" 110 mm
D	3-15/16" 100 mm	3-15/16" 100 mm	3-15/16" 100 mm	3-15/16" 100 mm	3-15/16" 100 mm
E	5-5/8" 143 mm	5-5/8" 143 mm	5-33/64" 140 mm	5-33/64" 140 mm	5-33/64" 140 mm
F	3-15/16" 100 mm	3-15/16" 100 mm	4-1/8" 105 mm	4-1/8" 105 mm	4-1/8" 105 mm
G	12-51/64" 325 mm	12-51/64" 325 mm	12-51/64" 325 mm	12-51/64" 325 mm	12-51/64" 325 mm

2.8 Positioning of sensor sockets

Models RTC 1000-4700 -80

(*) On the models RTC 3000-5500 -80 the safety fitting is flanged.

- 1 Outlet operating temperature thermowell (G 1/2") for n.2÷3 instrument bulb. Internal diameter probe sockets 7 mm. Thermowell length L170 mm
- 2 Over-temperature protection thermowell (G 1/2") for n.1 instrument bulb. Internal diameter probe sockets 15 mm. Thermowell length L170 mm
- 3 Inlet operating temperature thermowell (G 1/2") for n.2÷3 instrument bulb. Internal diameter probe sockets 7 mm. Thermowell length L100 mm

Boiler	BOILER RTC-80													
	1000		1300		1700		2300		3000		3800		4700	
Sensor manifold type Ø NPS	2 - 1/2" #150		3" #150		4" #150		4" #150		5" #150		5" #150		6" #150	
Thermowell length (*)	min.	max.	min.	max.	min.	max.	min.	max.	min.	max.	min.	max.	min.	max.
4 Exhaust Gas Detection and installation of a pressure switch for blocked duct (1/2" NPT)	2-1/2" 63 mm	5-7/8" 150 mm	2-1/2" 63 mm	5-7/8" 150 mm	2-1/2" 63 mm	7-7/8" 200 mm	2-1/2" 63 mm	7-7/8" 200 mm	2-1/2" 63 mm	7-7/8" 200 mm	2-1/2" 63 mm	7-7/8" 200 mm	2-1/2" 63 mm	11-13/16" 300 mm
5 LWCO (3/4" NPT)														
6 Gauge (3/4" NPT)	2 - 31/64" 63 mm	3 - 15/16" 100 mm	2 - 31/64" 63 mm	3 - 15/16" 100 mm	2 - 31/64" 63 mm	3 - 15/16" 100 mm	2 - 31/64" 63 mm	3 - 15/16" 100 mm	2 - 31/64" 63 mm	4 - 59/64" 125 mm	2 - 31/64" 63 mm	4 - 59/64" 125 mm	2 - 31/64" 63 mm	4 - 59/64" 125 mm
7 Manual reset high limit (3/4" NPT)														
8 Outlet temperature sensor (1/2" NPT)														

(*) The sensor sockets are not supplied.

⚠ The LWCO must be installed in a position higher than all other regulation and safety devices (over-temperature protection, operating temperature sensor and temperature gauge).

Model RTC 5500 -80

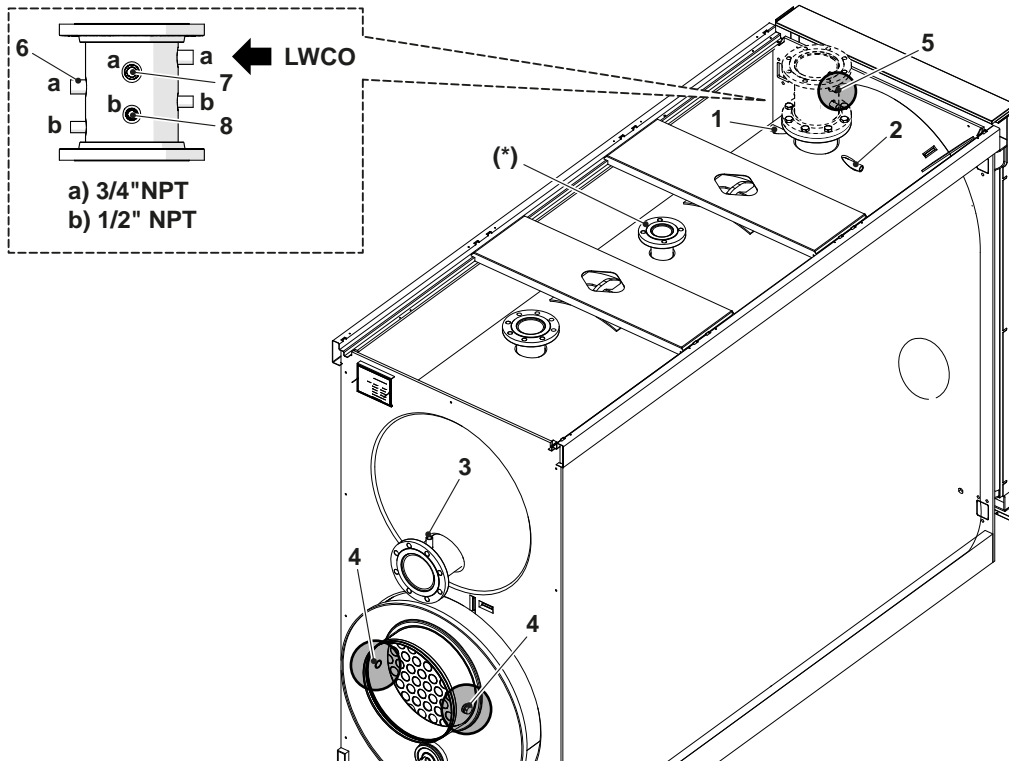

(*) On the models RTC 3000-5500 -80 the safety fitting is flanged.

- 1 Outlet operating temperature thermowell (G 1/2") for n.2÷3 instrument bulb. Internal diameter probe sockets 7 mm. Thermowell length L170 mm
- 2 Over-temperature protection thermowell (G 1/2") for n.1 instrument bulb. Internal diameter probe sockets 15 mm. Thermowell length L170 mm
- 3 Inlet operating temperature thermowell (G 1/2") for n.2÷3 instrument bulb. Internal diameter probe sockets 7 mm. Thermowell length L100 mm

Boiler		BOILER RTC-80	
		5500	
Sensor manifold type Ø NPS		6" #150	
Thermowell length (*)		min.	max.
4	Exhaust Gas Detection and installation of a pressure switch for blocked duct (1/2" NPT)	2-1/2" 63 mm	11-13/16" 300 mm
5	LWCO (3/4" NPT)		
6	Gauge (3/4" NPT)	2-31/64" 63 mm	4-59/64" 125 mm
7	Manual reset high limit (3/4" NPT)		
8	Outlet temperature sensor (1/2" NPT)		

(*) The sensor sockets are not supplied.

⚠ The LWCO must be installed in a position higher than all other regulation and safety devices (over-temperature protection, operating temperature sensor and temperature gauge).

2.8.1 Water-side pressure drop

BOILER RTC-80	$\Delta T=20^{\circ}F$		$\Delta T=30^{\circ}F$		$\Delta T=40^{\circ}F$		$\Delta T=60^{\circ}F$	
	Flow rate	Pressure drop	Flow rate	Pressure drop	Flow rate	Pressure drop	Flow rate	Pressure drop
	(GPM) (*)	(psi)	(GPM) (*)	(psi)	(GPM) (*)	(psi)	(GPM) (*)	(psi)
1000	95	0,67	63	0,30	48	0,19	32	0,08
1300	124	0,49	82	0,22	62	0,13	41	0,06
1700	162	0,44	108	0,20	81	0,12	54	0,05
2300	219	1,86	146	0,83	109	0,42	73	0,19
3000	285	1,76	190	0,78	143	0,44	95	0,20
3800	361	1,36	241	0,60	181	0,38	120	0,17
4700	447	1,45	298	0,64	223	0,41	149	0,18
5500	523	2,18	348	0,97	261	0,52	174	0,23

At 95% efficiency and full firing rate

BOILER RTC-80	$\Delta T=20^{\circ}F$		$\Delta T=30^{\circ}F$		$\Delta T=40^{\circ}F$		$\Delta T=60^{\circ}F$	
	Flow rate	Pressure drop	Flow rate	Pressure drop	Flow rate	Pressure drop	Flow rate	Pressure drop
	(GPM) (*)	(psi)	(GPM) (*)	(psi)	(GPM) (*)	(psi)	(GPM) (*)	(psi)
1000	92	0,63	61	0,28	46	0,18	31	0,08
1300	120	0,46	80	0,20	60	0,12	40	0,05
1700	156	0,41	104	0,18	78	0,11	52	0,05
2300	212	1,74	141	0,78	106	0,39	71	0,18
3000	276	1,65	184	0,73	138	0,41	92	0,18
3800	350	1,28	233	0,57	175	0,36	117	0,16
4700	432	1,36	288	0,60	216	0,38	144	0,17
5500	506	2,04	337	0,91	253	0,49	169	0,22

At 92% efficiency and full firing rate

BOILER RTC-80	$\Delta T=20^{\circ}F$		$\Delta T=30^{\circ}F$		$\Delta T=40^{\circ}F$		$\Delta T=60^{\circ}F$	
	Flow rate	Pressure drop	Flow rate	Pressure drop	Flow rate	Pressure drop	Flow rate	Pressure drop
	(GPM) (*)	(psi)	(GPM) (*)	(psi)	(GPM) (*)	(psi)	(GPM) (*)	(psi)
1000	87	0,56	58	0,25	44	0,16	29	0,07
1300	113	0,41	75	0,18	57	0,11	38	0,05
1700	148	0,37	99	0,16	74	0,10	49	0,04
2300	200	1,56	133	0,69	100	0,35	67	0,16
3000	261	1,48	174	0,66	131	0,37	87	0,16
3800	331	1,14	220	0,51	165	0,32	110	0,14
4700	409	1,22	273	0,54	204	0,34	136	0,15
5500	479	1,83	319	0,81	239	0,44	160	0,19

At 87% efficiency and full firing rate

(*) Units shown are in US Gallons.

2.8.2 Flow limits

RTC-80 boilers do not require a minimum flow rate in order to maintain warranty. The boiler has been designed to operate with a temperature difference between the supply and return of up to 100°F. Flow should be initiated with the start of the burner to minimize temperature fluctuations and control deviations. The field installed manual reset high limit (as required by CSD-1) must be fitted to the instrument tapping of the heating supply, set to 210°F and electrically connected into the Control unit or the burner enable/disable circuit directly.

RTC-80 boilers can operate with zero flow, and do not require a minimum flow rate.

A minimum flow is recommended only to provide heat transfer, and the maximum flow to prevent erosion.

BOILER RTC-80	Flow Limits		
	Maximum	Minimum	
1000	130	12	GPM (*)
1300	160	15	GPM (*)
1700	200	20	GPM (*)
2300	290	30	GPM (*)
3000	370	40	GPM (*)
3800	480	50	GPM (*)
4700	580	60	GPM (*)
5500	690	70	GPM (*)

(*) Units shown are in US Gallons.

2.8.3 Water quality requirements

The manufacturer recommends the use of water as heat transfer fluid for the central heating system. A chemical treatment system must be provided for this water.

The heat transfer fluid (water) for the central heating circuit must conform to the quality parameters given in the following table:

Chemical and physical requirements of heating system water			
		Initial filling water	Regular service water (*)
ph		6-8	7.5-9.5
Hardness	°fH / ppm	< 5° / 50	< 5° / 50
Electrical conductivity	µs/cm		< 100
Chlorides	mg/l / ppm		< 10 / 10
Sulphides	mg/l / ppm		< 10 / 10
Nitrides	mg/l / ppm		< 10 / 10
Iron	mg/l / ppm		< 0.5 / 0.5

(*) system water values after 8 weeks of operation;

(**) higher values are due to corrosion, to be eliminated.

⚠ NOTICE:

If it proves impossible to treat the heating system water supply properly because the water charging system is automatic and uncontrolled, if there are no barriers installed to prevent water oxygenation and if the heating system includes an open expansion vessel, then the boiler itself must be separated from the heating system by means of a heat exchanger.

If the hardness of the water exceeds the value specified in the table, it is mandatory to install a water softening system.

⚠ NOTICE:

- Chemical products used for water treatment must be compatible with applicable water pollution laws.
- Provided they are properly applied, these laws guarantee the safe functioning of the heating system.

2.8.4 Central heating system

Possible causes for corrosion and limescale

Typical problems encountered in central heating systems include:

- the breakage of heated surfaces through overheating caused by the thermal insulation of limescale deposits on the water side
- oxygen corrosion
- deposit corrosion
- stray current corrosion
- diffused and localized acid corrosion.

The technical details provided in this section refer specifically to domestic and industrial hot water heating systems with working temperatures up to 210°F (99°C).

2.8.5 New central heating systems

Mistakes to avoid and precautions.

To eliminate contact between system water and the air, the following is required:

- ensure that the expansion vessel is a closed vessel, and of the correct size and pre-charge pressure (the pressure should be checked periodically)
- ensure that the system is always kept at a pressure higher than atmospheric pressure at all points (including the pump suction side) and at all operating conditions (precisely because the seals, gaskets and joints in a water circuit are designed to resist pressure from within, but not to resist a vacuum within)
- ensure that no part of the system is made from materials that are permeable to gases (e.g. plastic pipes with no oxygen barrier used in floor heating systems).

⚠ NOTICE:

The original system filling water and any topping up water must always be filtered (using synthetic or metal mesh filters with a filtration rating of no less than 50 microns) to prevent sludge from forming and triggering deposit induced corrosion.

⚠ NOTICE:

We recommend fitting an 80 mesh dirt filter externally to the boiler return to prevent contamination of the boiler by the water source.

⚠ NOTICE:

- Loss of water from the system, and the consequential need to add water, can be caused not only by leaks from the circuit, but also from the incorrect sizing of the expansion vessel or precharge pressure. (If normal thermal expansion causes pressure in the system to increase beyond the setting of the safety valve, that safety valve will open continuously.)
- The expansion vessel size should be corrected to prevent unnecessary safety valve blow-off.

The heating system should not need any further topping up once it is filled and bled of all air.

Any top-ups need to be monitored (by a meter), treated and recorded in the heating system's technical log. The presence of a water softener in conjunction with an automatic filling system is not sufficient to ensure proper performance.

If more than one boiler is installed in a large system, all boilers must be switched on at the same time to ensure that any possible limescale formation is uniformly distributed.

2.8.6 Reconditioning old heating systems

Frequent mistakes and necessary precautions.

If a boiler must be replaced, do not refill the entire central heating circuit if the quality of water in it conforms to requirements.

If the quality of water fails to conform to requirements, either recondition the old water or separate the water circuits (water in the boiler circuit must conform to requirements).

Conclusions

Never forget that proper water conditioning and proper heating system design not only guarantee safety and security but also ensures significant savings in maintenance costs and overall thermal efficiency.

2.8.7 Elimination of air and gas from central heating system

When designing new heating systems, it is necessary to eliminate the air and other gases that form in the system.

Recently added fill or top-up water loses much of its volume in the first few days because it releases gases. With new systems you should therefore initially check the heating water pressure on a daily basis, and then at gradually longer intervals. Air and gas in the water system not only causes the corrosion problems listed above, but also reduces thermal efficiency, causing pump failure and noise and vibration throughout the heating system. Air bubbles and gas inevitably form in heating circuits during normal functioning, especially if the precautions listed above are not fully respected.

In particular:

- as temperature increases, oxygen becomes less water-soluble and bubbles begin to form;
- CO₂ (carbon dioxide) is generated as the carbonates of calcium and magnesium precipitate out;
- the chemical oxidation of the metals in the system also generates hydrogen.

These gases must be eliminated as they are formed. The system needs to be designed and installed so that all gases can be vented quickly, easily, and effectively.

2.8.8 Use of antifreeze

Do not use automotive silicate-based antifreeze in the heating system.

In areas where freezing may occur, an antifreeze may be added to the system water as protection. Please adhere to the specifications provided by the antifreeze manufacturer.

- Use the anti-freeze manufacturer's data to determine the anti-freeze ratio for the desired freeze protection temperature.
- Do not exceed 50% antifreeze mix ratio and do not use antifreeze other than specifically made for hot water heating systems.

- the chemical oxidation of the metals in the system also generates hydrogen.

2.8.9 Glycol

The percentage of propylene glycol which can be used is dependent on the maximum delivery temperature and the project ΔT as defined by the generator.

To calculate the freezing temperature associated with the mix and the maximum percentage to be used, please see the technical datasheet for the product used.

⚠ The values given in the tables refer to the **RIELLO** product.

Anti-freeze effect		
Glycol (%)	Temperature (°C)	Temperature (°F)
55	-40,4	-40,7
50	-32,4	-26,3
45	-26,0	-14,8
40	-21,5	-6,7
35	-17,6	0,3
30	-14,0	6,8
25	-10,7	12,7
20	-7,0	19,4
15	-4,0	24,8
10	-2,0	28,4

Mix boiling point								
P (bar)	Glycol (%)							T (°)
	25	30	35	40	45	50	55	
11,0	186,0	187,0	186,0	188,0	189,0	189,0	189,5	°C
	366,8	368,6	366,8	370,4	372,2	372,2	373,1	°F
10,0	181,5	182,0	182,5	183,0	184,0	185,0	186,5	°C
	358,7	359,6	360,5	361,4	363,2	365,0	367,7	°F
9,0	176,5	177,0	177,5	178,0	179,5	181,0	182,5	°C
	349,7	350,6	351,5	352,4	355,1	357,8	360,5	°F
8,0	171,5	172,0	172,5	173,0	174,0	175,0	176,0	°C
	340,7	341,6	342,5	343,4	345,2	347,0	348,8	°F
7,0	166,0	166,5	167,0	167,5	168,0	168,5	170,0	°C
	330,8	331,7	332,6	333,5	334,4	335,3	338,0	°F
6,0	159,0	159,5	160,5	161,0	161,5	162,0	163,5	°C
	318,2	319,1	320,9	321,8	322,7	323,6	326,3	°F
5,0	152,5	153,0	154,0	155,0	156,0	157,0	158,0	°C
	306,5	307,4	309,2	311,0	312,8	314,6	316,4	°F
4,0	144,5	145,0	145,5	146,0	147,0	148,0	149,0	°C
	292,1	293,0	293,9	294,8	296,6	298,4	300,2	°F
3,5	141,5	142,0	142,5	143,0	143,5	144,0	145,0	°C
	286,7	287,6	288,5	289,4	290,3	291,2	293,0	°F
2,0	122,5	123,0	123,5	124,0	125,0	126,0	127,0	°C
	252,5	253,4	254,3	255,2	257,0	258,8	260,6	°F
1,0	100,5	101,0	101,5	102,0	103,0	104,0	105,0	°C
	212,9	213,8	214,7	215,6	217,4	219,2	221,0	°F









IMPORTANT INFORMATION REGARDING HEAT-TRANSFER FLUIDS

Heat-transfer fluids are particularly important for protecting the system: efficient heat exchange, thanks to a good specific heat capacity; anti-freeze properties, important for the life of the system in the winter; and anti-corrosion properties to preserve the heating system components.

When choosing a heat-transfer fluid, consider the following:

- **toxicity** in the event of leakage, contaminating domestic water or water for animal/human use/contact
- **biodegradability** in the event of leakage into the environment

All heat-transfer fluids recommended by **RIELLO** are non-toxic and in large part biodegradable.

-  Choose the liquid carefully and manage the heating system correctly to keep monitoring and maintenance work to a minimum, and reduce fluid changes.
-  Use concentrated, non-polluting propylene glycol-based antifreeze liquid with corrosion inhibitors for heating systems.
-  Do not use a mixture with other antifreeze liquids, rather always use the same one.
-  Use a liquid that is not chemically hazardous.
-  It is mandatory to check the percentage of glycol based on the antifreeze effect on the data sheet for the purchased product.
-  It is recommended to check the compatibility of the purchased product with the circuit sealing materials, e.g., elastomers or plastics.
-  It is recommended to use a filter in the primary circuit to purify the propylene glycol.
-  The system may not have galvanized tanks or pipes on the primary side, as zinc can be dissolved by mixtures of propylene glycol and water.

2.9 Typical water system schematics

The following P&ID represent the typical arrangements for the most common types of installation and they are only a suggestion for the installer that is responsible for all equipment and details required by local laws.

⚠ The DHW and central heating circuits must incorporate expansion vessels of adequate capacity as well as suitably rated safety valves. The condensate drain must be connected to a suitable collection and drain system.

⚠ The selection and the installation of the components of the system is the responsibility of the installer, who must operate in accordance with good practice and current Legislation.

⚠ If needed, water supplies and recovery circuits must be conditioned by suitable treatment systems. Refer to the values listed in the table in the paragraph Water quality requirements.

⚠ CAUTION: It is prohibited to operate the circulators without water.

⚠ The use of automatic fill valves is not recommended by Riello S.p.A.. The system should be pressurized during commissioning and the fill valve closed. Routine maintenance must include regular checks of the system pressure to identify leaks in the hydronic system. All fill water must be conditioned in line with the water quality requirements outlined in this manual. For installations where a manual fill system is impractical the fill system must be monitored to ensure the fill water is properly conditioned in line with the water quality requirements. System leaks should be sealed to prevent a constant flow of fill water which can create deposits in the system and boiler vessel. However, if this system load should be automatic, it is recommended to treat the water against limescale using a water softener.

Single Boiler Piping Schematic Type A

Models RTC 1000-4700 -80

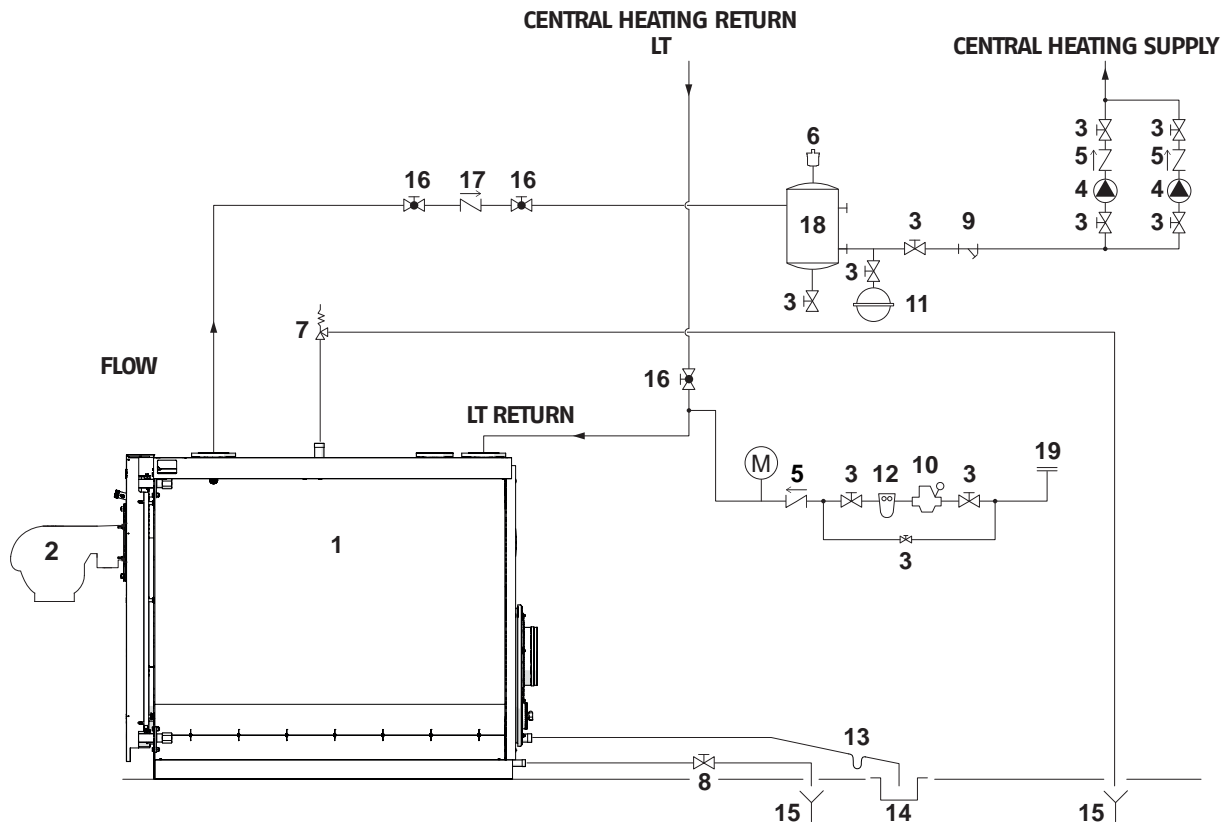

1	Boiler	6	Automatic vent valve	12	Water softener filter	18	Air separator
2	Burner	7	Boiler safety valve	13	Siphon	19	Water inlet
3	Isolation valves	8	Boiler drain valve	14	Condensate outlet		
4	Central heating system pump	9	Y strainer	15	Drain	M	Pressure gauge
5	Non-return valves	10	Pressure reducer	16	Isolation valve	HT	High Temperature
		11	Expansion tank	17	Non-return valve	LT	Low Temperature

Single Boiler Piping Schematic Type B

Model RTC 5500 -80

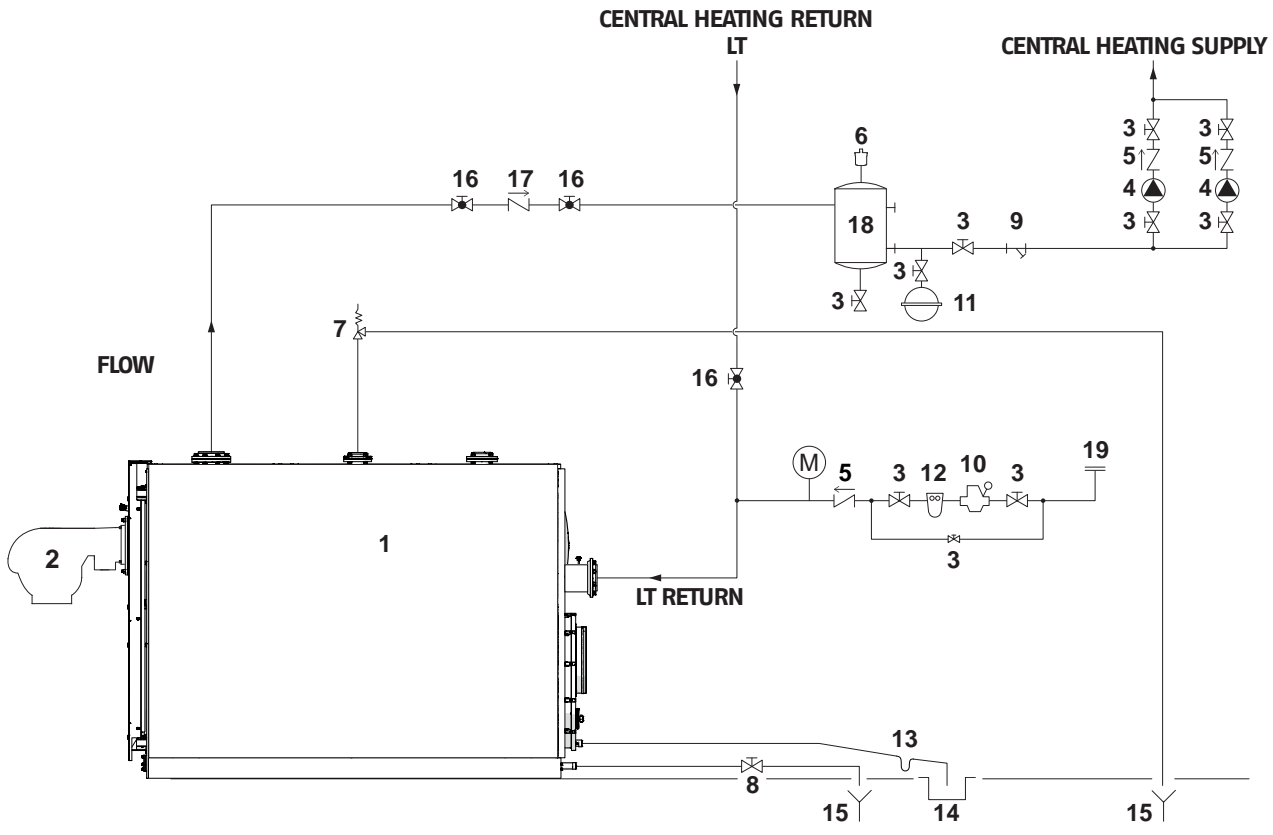

- | | | | | | | | |
|---|-----------------------------|----|----------------------|----|-----------------------|----|-----------------|
| 1 | Boiler | 6 | Automatic vent valve | 12 | Water softener filter | 18 | Air separator |
| 2 | Burner | 7 | Boiler safety valve | 13 | Siphon | M | Pressure gauge |
| 3 | Isolation valves | 8 | Boiler drain valve | 14 | Condensate outlet | LT | Low Temperature |
| 4 | Central heating system pump | 9 | Y strainer | 15 | Drain | | |
| 5 | Non-return valves | 10 | Pressure reducer | 16 | Isolation valve | | |
| | | 11 | Expansion tank | 17 | Non-return valve | | |

Single Boiler Combination Heating & Domestic Water Plant

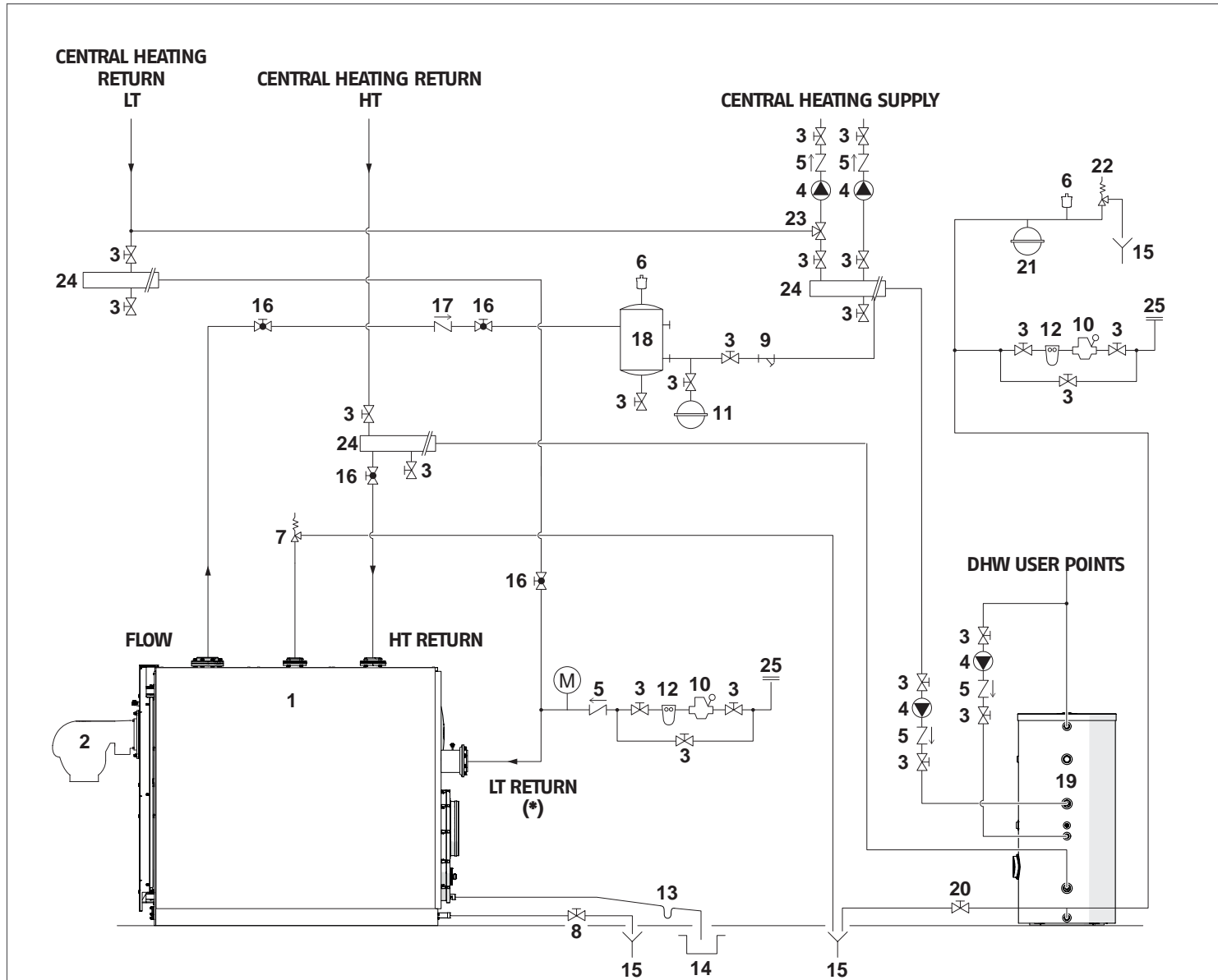

- | | | | | | | | |
|----|-----------------------------|----|-----------------------------|----|---------------------------------|-----|--|
| 1 | Boiler | 11 | Expansion tank | 21 | DHW circuit expansion tank | HT | High temperature |
| 2 | Burner | 12 | Water softener filter | 22 | Storage tank safety valve | LT | Low temperature |
| 3 | Isolation valves | 13 | Siphon | 23 | 3-way valve | (*) | On the RTC 1000-80 to RTC 4700-80 the low temperature heating return is located on the top of the boiler. See "Single Boiler Piping Schematic Type A". |
| 4 | Central heating system pump | 14 | Condensate outlet | 24 | Central heating system manifold | | |
| 5 | Non-return valves | 15 | Drain | 25 | Water inlet | | |
| 6 | Automatic vent valve | 16 | Isolation valve | M | Pressure gauge | | |
| 7 | Boiler safety valve | 17 | Non-return valve | | | | |
| 8 | Boiler drain valve | 18 | Air separator | | | | |
| 9 | Y strainer | 19 | Domestic water storage tank | | | | |
| 10 | Pressure reducer | 20 | Storage tank drain | | | | |

Multiple Boiler Piping Schematic with Sequencing Panel

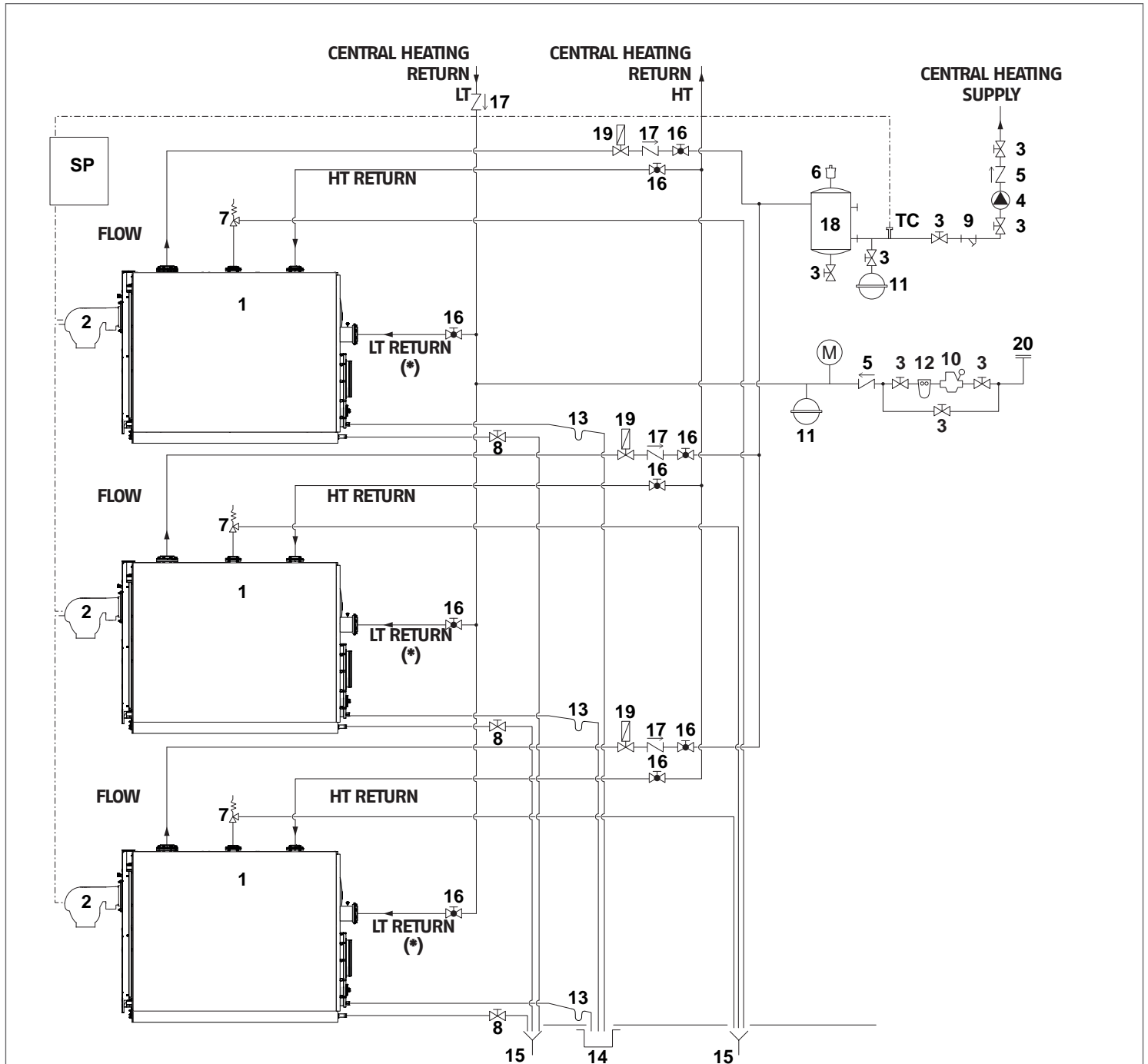

- | | | | | |
|---|-----------------------------|----|---------------------------|---------------------|
| 1 | Boiler | 10 | Pressure reducer | valve |
| 2 | Burner | 11 | Expansion tank | 20 |
| 3 | Isolation valves | 12 | Water softener filter | Water inlet |
| 4 | Central heating system pump | 13 | Siphon | M |
| 5 | Non-return valves | 14 | Condensate outlet | Pressure gauge |
| 6 | Automatic vent valve | 15 | Drain | SP |
| 7 | Boiler safety valve | 16 | Isolation valve | TC |
| 8 | Boiler drain valve | 17 | Non-return valve | Control temperature |
| 9 | Y strainer | 18 | Air separator | Electrical signal |
| | | 19 | Motorized isolation valve | HT |
| | | | | High temperature |
| | | | | LT |
| | | | | Low temperature |
| | | | | (*) |
| | | | | On the RTC 1000-80 |

to RTC 4700-80 the low temperature heating return is located on the top of the boiler. See "Single Boiler Piping Schematic Type A".

Multiple Boiler Piping with Primary and Secondary Piping

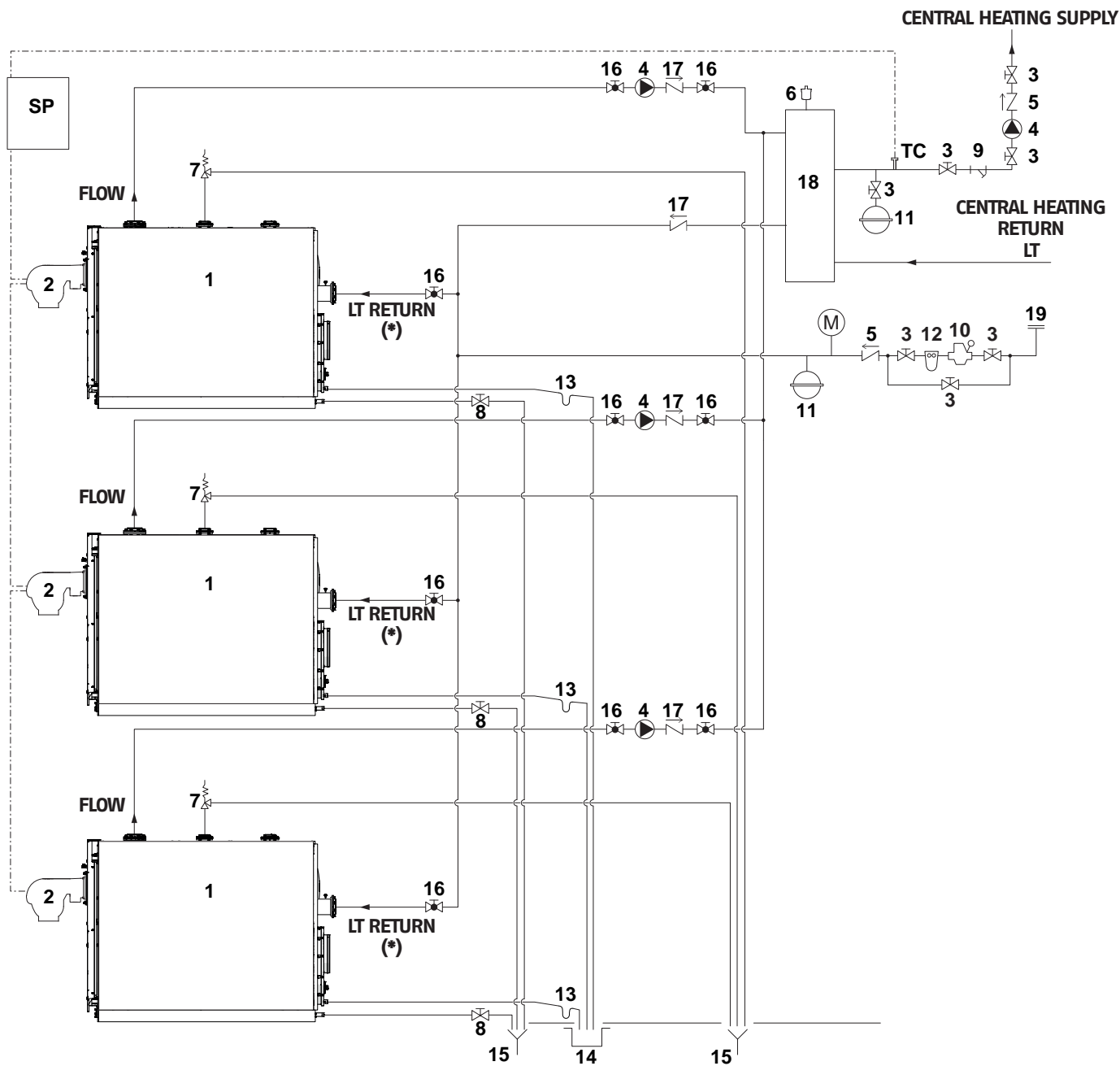

- | | | | | | | |
|---|-----------------------------|----|-----------------------|-----------|---------------------|-----|
| 1 | Boiler | 9 | Y strainer | 18 | Mixer tank | (*) |
| 2 | Burner | 10 | Pressure reducer | 19 | Water inlet | |
| 3 | Isolation valves | 11 | Expansion tank | M | Pressure gauge | |
| 4 | Central heating system pump | 12 | Water softener filter | SP | Sequencing panel | |
| 5 | Non-return valves | 13 | Siphon | TC | Control temperature | |
| 6 | Automatic vent valve | 14 | Condensate outlet | · _ · _ · | Electrical signal | |
| 7 | Boiler safety valve | 15 | Drain | HT | High temperature | |
| 8 | Boiler drain valve | 16 | Isolation valve | LT | Low temperature | |
| | | 17 | Non-return valve | | | |

(*) On the **RTC 1000-80** to **RTC 4700-80** the low temperature heating return is located on the top of the boiler. See "Single Boiler Piping Schematic Type A".

Multiple-Boiler Piping with Motorized Sequencing Valves

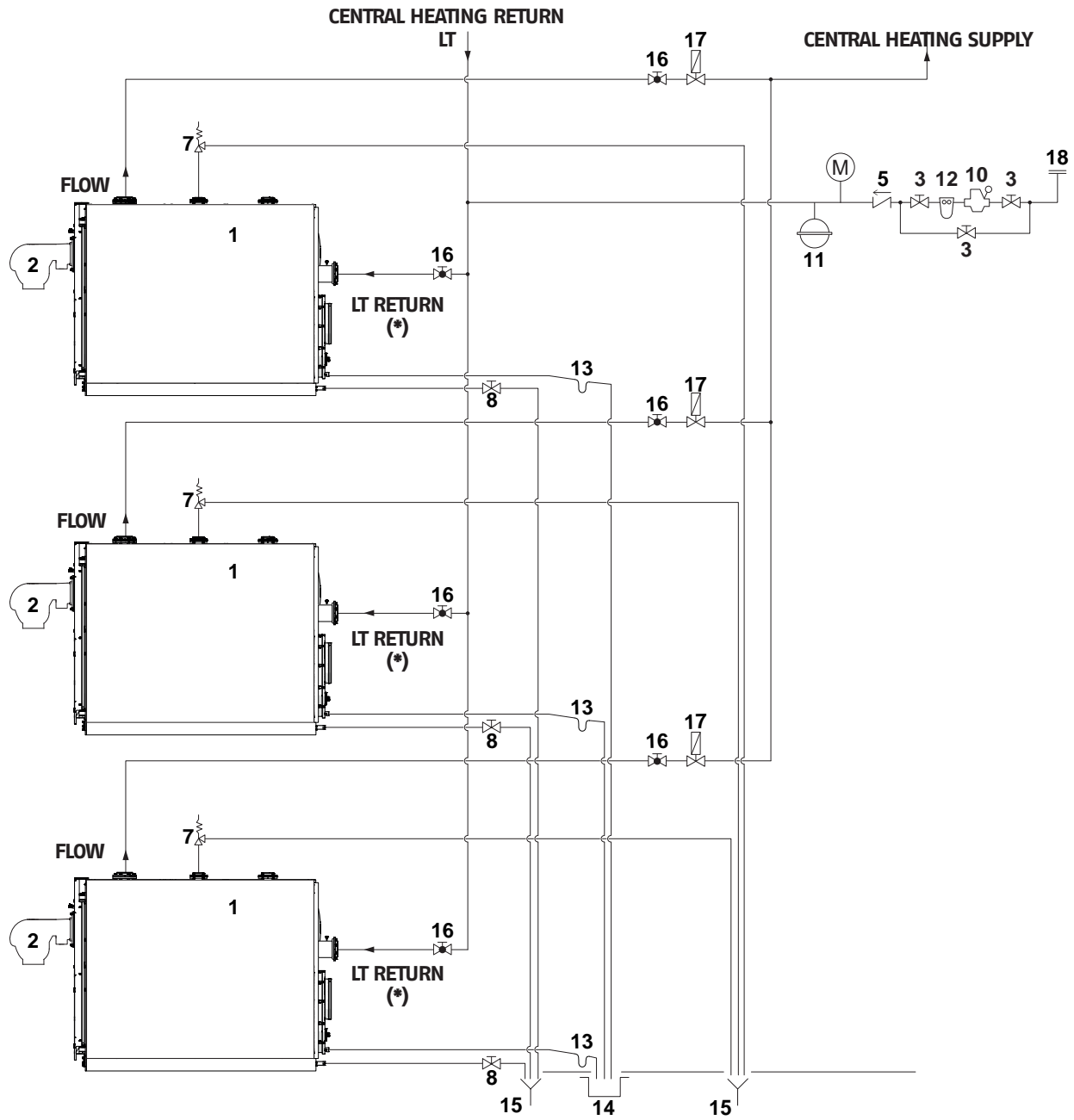

- | | | | | | | |
|---|-----------------------------|----|-----------------------|----|----------------------------|-----|
| 1 | Boiler | 8 | Boiler drain valve | 16 | Isolation valve | (*) |
| 2 | Burner | 9 | Y strainer | 17 | Motorized sequencing valve | |
| 3 | Isolation valves | 10 | Pressure reducer | 18 | Water inlet | |
| 4 | Central heating system pump | 11 | Expansion tank | | | |
| 5 | Non-return valves | 12 | Water softener filter | | | |
| 6 | Automatic vent valve | 13 | Siphon | M | Pressure gauge | |
| 7 | Boiler safety valve | 14 | Condensate outlet | HT | High temperature | |
| | | 15 | Drain | LT | Low temperature | |

(*) On the **RTC 1000-80** to **RTC 4700-80** the low temperature heating return is located on the top of the boiler. See "Single Boiler Piping Schematic Type A".

Two-Boiler Combination Heating & Domestic Water Plant

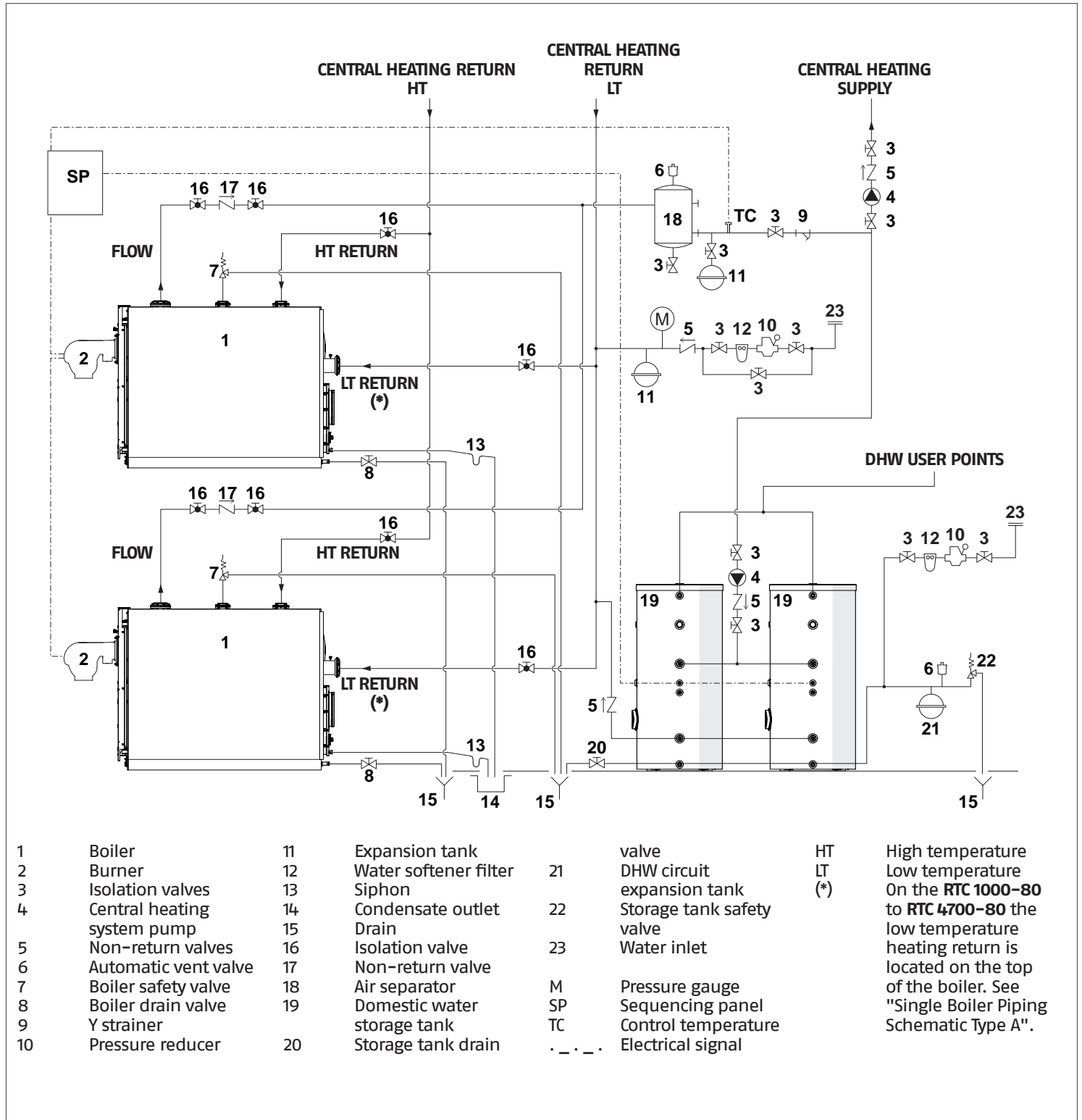

Multi-Boiler Combination

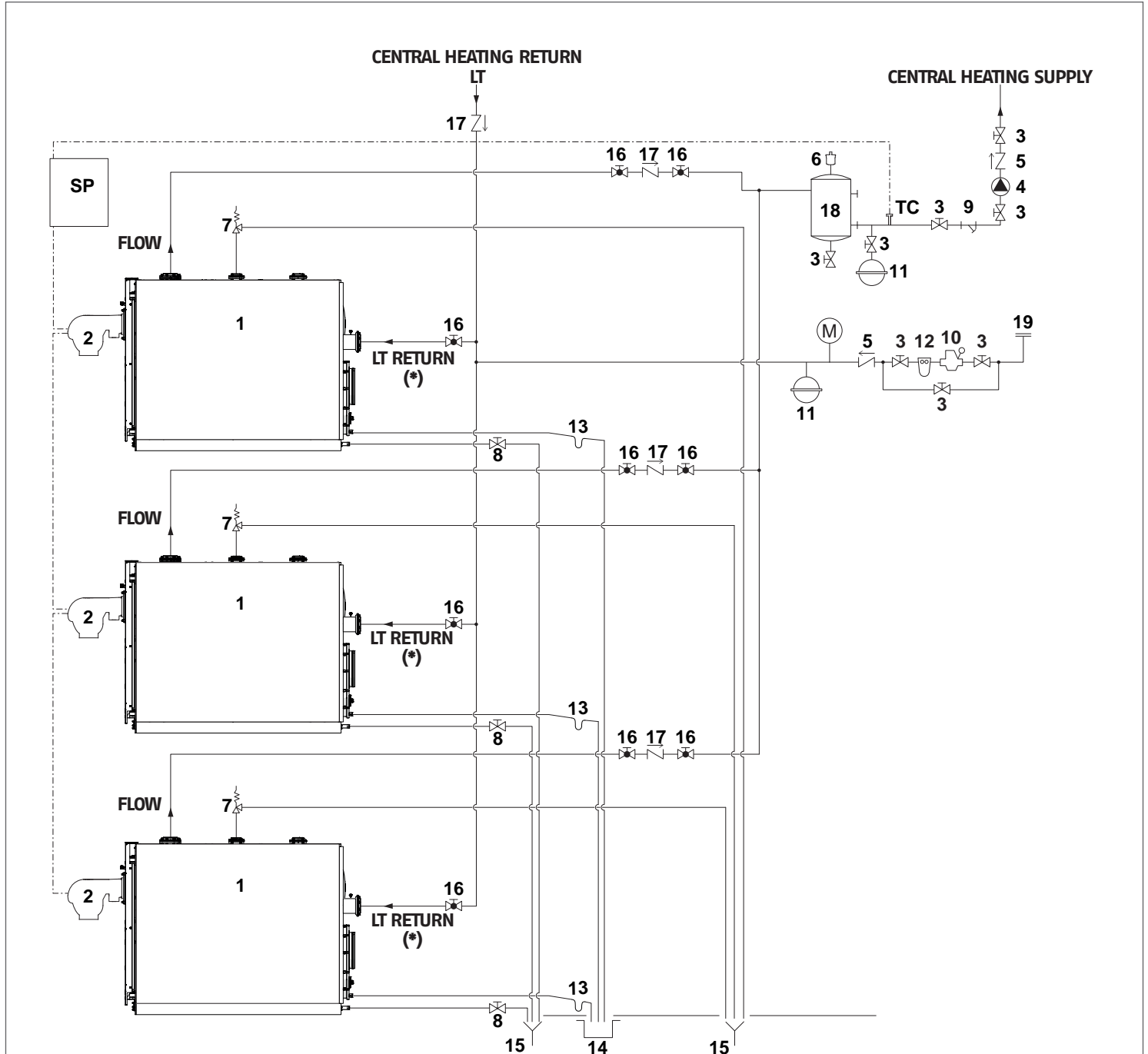

- | | | | | | | | |
|---|-----------------------------|----|-----------------------|-----------|---------------------|-----|---|
| 1 | Boiler | 9 | Y strainer | 18 | Air separator | (*) | On the RTC 1000-80 to RTC 4700-80 the low temperature heating return is located on the top of the boiler. See "Single Boiler Piping Schematic A". |
| 2 | Burner | 10 | Pressure reducer | 19 | Water inlet | | |
| 3 | Isolation valves | 11 | Expansion tank | M | Pressure gauge | | |
| 4 | Central heating system pump | 12 | Water softener filter | SP | Sequencing panel | | |
| 5 | Non-return valves | 13 | Siphon | TC | Control temperature | | |
| 6 | Automatic vent valve | 14 | Condensate outlet | . _ . _ . | Electrical signal | | |
| 7 | Boiler safety valve | 15 | Drain | HT | High temperature | | |
| 8 | Boiler drain valve | 16 | Isolation valve | LT | Low temperature | | |
| | | 17 | Control valve | | | | |

2.10 Draining the condensate

RTC-80 condensing boilers produce a flow of condensate that varies according to operating conditions.

The maximum hourly production of condensate for each model is given in the table in the paragraph Neutralizing the condensate. The condensate drain system must be suitably dimensioned to cope with the flow produced. Also, pipe and hose diameter must not be less than 1" for RTC 1000-1300 -80 and 1-1/4" for RTC 1700-5500 -80 at any point. This diameter corresponds to that of the boiler's condensate drain fitting (7).

Collection and connection to the drain system must conform to applicable national and local codes.

To prevent combustion fumes from leaking into the air of the boiler room, the condensate drain pipe must incorporate a siphon creating a minimum head equivalent to the furnace pressure plus 1" W.C..

The connecting pipes between the boiler, siphon and waste water drain pit must be laid at a minimum down slope of 3° and must be installed in such a way as to prevent any build-up of condensate.

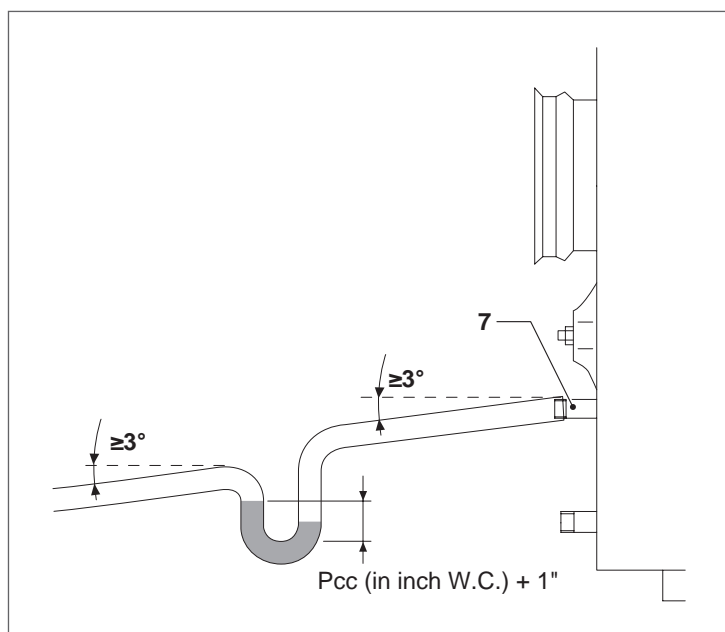

2.11 Neutralizing the condensate

Installation of a condensate neutralization kit is always recommended. The following table states the rate of condensate flow produced by the boiler.

BOILER RTC-80	Condensate Production		Condensate Production	
1000	8.42	GPH	31.9	l/h
1300	10.80	GPH	40.9	l/h
1700	13.78	GPH	52.2	l/h
2300	19.49	GPH	73.8	l/h
3000	23.24	GPH	88.0	l/h
3800	29.42	GPH	111.14	l/h
4700	35.05	GPH	132.7	l/h
5500	42.13	GPH	159.5	l/h

At full load with $T_{in}=86^{\circ}F$ and $T_{out}=122^{\circ}F$

⚠ All connecting hoses must be kept as straight and as short as possible. Any curves or sharp bends can lead to the hoses becoming clogged and can therefore prevent proper condensate discharge.

⚠ Refer to the manual supplied with the kit for installation and connection instructions.

⚠ NOTICE: The boiler room's condensate drain pit must be located at a lower level than the fitting on the neutralization unit.

If it ever proves necessary to neutralize the condensate that forms in the flue gas stack, connect the condensate drain fittings of the boiler and flue gas stack together using a 'T' union and connect the leg of the 'T' to the inlet of the neutralization unit.

2.12 Combustion gas exhaust

The flue pipe (1) and the connection to the stack (2) must conform to applicable national and local laws and standards. Flue pipe must be rigid, impermeable to fumes, able to withstand mechanical strain, heat, and the action of combustion gases and the condensate formed by them.

The stack must be fitted with a condensate trap and drain and the flue gas exhaust pipe must be installed at a slope of at least 3° towards the boiler. All condensate should be treated through a neutralization media before being eliminated to the floor drain (3).

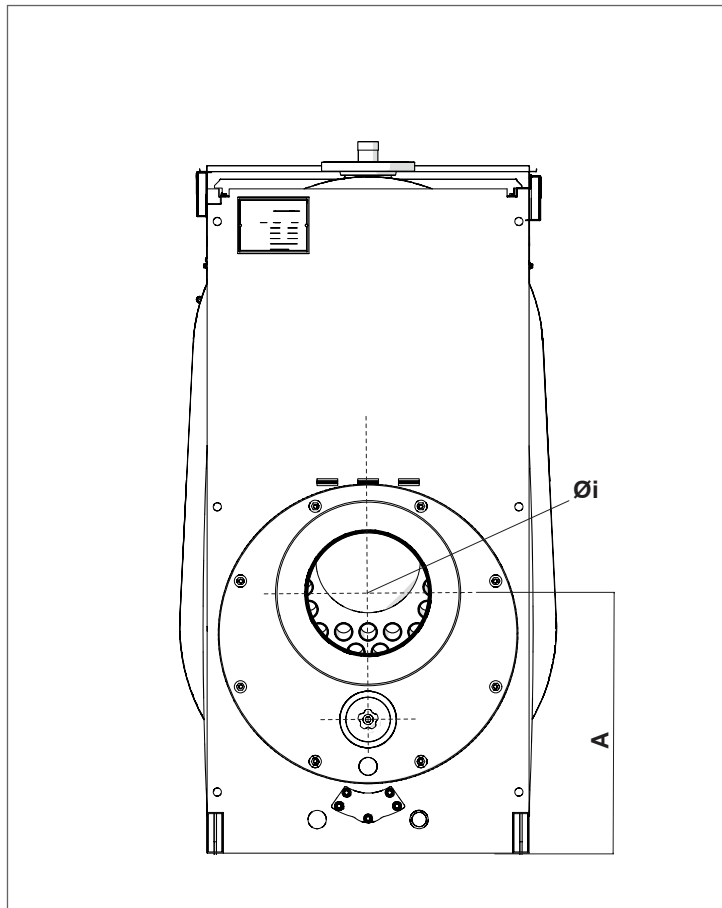
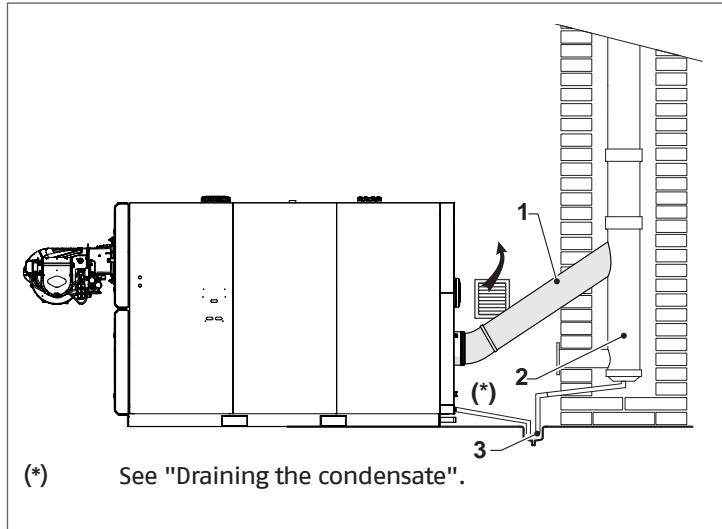

Description	Sym- bol	Unit	BOILER RTC-80			
			1000	1300	1700	2300
Height of flue gas outlet	A	inch (mm)	21 1/16 (535)		25 (635)	
Diameter of flue gas fitting	Øi	inch (mm)	9 27/32 (250)		11 13/16 (300)	

Description	Sym- bol	Unit	BOILER RTC-80			
			3000	3800	4700	5500
Height of flue gas outlet	A	inch (mm)	26 3/4 (680)		28 3/8 (720)	31 11/16 (805)
Diameter of flue gas fitting	Øi	inch (mm)	13 25/32 (350)		15 3/4 (400)	17 23/32 (450)

- ⚠** The boiler takes in combustion air from the boiler room. Room vents must therefore be compliant with the relevant technical standards.
- ⊖** Do not obstruct or restrict the air vents in the room where the boiler is installed. Adequate ventilation is essential for correct combustion and functioning.

2.12.1 Venting Requirements

⚠ WARNING: Risk of system damage or personal injury! The vent system could fail, causing flue gas leakage, resulting in severe personal injury or death.

- Use only an approved vent starter coupling and approved vent pipe from **RIELLO**
- Do not mix components from different systems.

⚠ NOTICE: How to design the flue gas outlet

- Connect an oil-fired unit to a vent having sufficient draft at all times to ensure safe and proper operation of the unit.

The RTC Boiler is a category II or IV appliance and the exhaust vent materials must be UL listed for use with a category IV appliance: operating temperatures of up to 240 °F, positive pressure, condensing flue gas. Currently, UL Listed vents of AL29-4C or 316L stainless steel must be used with the RTC Boiler. Proper clearances to combustibles must be maintained per UL and vent manufacturer instructions.

The specifying engineer should dictate flue venting as appropriate to the installation.

The vent system should be designed to facilitate smooth travel for both the intake and exhaust. Avoid the use of bullhead tees and back-to-back 90 degree elbows. The exhaust system must never be installed in a downward fashion. Be sure to follow all instructions provided by the vent manufacturer.

Keep the supply of combustion air free of corrosive substances (e.g. halogenated hydrocarbons that contain chlorine or fluorine compounds). This will help prevent corrosion. Never use or store chlorinated cleaning agents or halogenated hydrocarbons (as contained in spray cans, solvents or cleaning agents, paints and adhesives, for example) in the boiler room.

UL, NFPA 54 & 211, ANSI Z223.1 and CSA B149.1 guidelines are often the basis for state and local codes. Follow the guidelines of these recognized agencies unless codes applicable to the installation site are most stringent. The venting and combustion air systems must meet all applicable code requirements. Where code differs from the instructions provided with the equipment, code will take precedence.

Constant pressure at the flue gas outlet is not required. Size the flue system to limit pressure variations. The maximum allowable breech pressure for design of the flue system is positive 0.2" W.C. for proper combustion and light off.

A draft control system may be required to ensure proper draft when two or more boilers are connected to a common stack. Consult the flue material manufacturer for design calculations and recommendations.

2.12.2 Code Required Vent Terminations

Horizontal Terminations:

- Vent terminations should be at least 4 feet below, 1 foot above or 4 feet horizontally from any window, door or gravity air inlet of a building.
- The termination shall be at least 6 feet away from any other building opening, gas utility meter, service regulator or the like.
- The termination shall be at least 6 feet away from the combustion air intake of any other appliance.
- The bottom of the vent terminal should be at least 12 inches above both finished grade and any snow accumulation point.
- Vent should not terminate over public walkways or over an area where condensate or vapor could create a nuisance or be detrimental to the operation of regulators, meters and other equipment.
- Discharges should not be in wind-blocked areas, corners, or directly adjacent to vegetation.

Vertical Terminations:

- Roof penetrations should follow all appliance codes and the vent manufacturer's instructions. The vent should never be installed at less than the required clearances to combustible materials per UL, NFPA and local codes. "Double-wall or thimble" assemblies are required when penetrating combustible walls and roofs.
- Vertical discharges should extend at least 2 feet above the roof through properly flashed penetrations and at least 2 feet above anything within a 10 foot horizontal diameter. Discharges that extend more than 2 feet above the roof must be laterally supported.
- If the vent systems is to be connected to an existing stack, the stack must be UL Listed for Category II or IV appliances (capable of 240 °F, positive pressure and condensing flue gas operation).
- Masonry stacks must be lined and the vent penetration must terminate flush with and be sealed to this liner. Vents may enter the stack through the bottom or side.
- RTC Boiler vent systems must not be interconnected to any other venting system; The RTC Boiler is designed to maintain its own vent system.
- The exhaust vent must be pitched up toward the termination a minimum of 1/4 inch per foot of length. Condensate must flow back to the boiler flue collector freely, without accumulating in the vent.

2.12.3 Combustion Air from outside the building

Two permanent openings method

If outside combustion air is required, the room shall have two permanent louvered openings to the outdoors. Each opening must have a minimum free area of 1 square inch for each 4,000 Btu/hr of total input rating of all fuel burning equipment in the space. When the air is supplied to the room via ducts, two ducts must be used. Vertical ducts and openings must have a minimum free area of 1 square inch for each 4,000 Btu/hr of the total input rating of all fuel burning equipment in the space. Horizontal ducts and openings must have a minimum free area of 1 square inch for each 2,000 Btu/hr of the total input rating of all fuel burning equipment in the space.

One permanent opening method

If outside combustion air is required, the room shall have one permanent louvered opening to the outdoors. The opening must communicate directly with the outdoors or through a duct in either a vertical or horizontal arrangement. The opening must have a minimum free area of 1 square inch for each 3,000 Btu/hr of total input rating of all fuel burning equipment in the space.

The free area of the opening must take into account restrictions from louvers and screens. The louver manufacturer should be consulted for the percentage of free area available. When free area is not known, metal louvers typically have 60–70% of free area, wooden louvers have between 20–25% of free area. Louvers should be in a fixed position or interlocked with equipment so that they open automatically during equipment operation. The combustion air damper opening shall be located as follows: top louver shall begin within 12" of the ceiling and the bottom louver within 12" of the floor as prescribed in NFPA 54.

Direct intake method

If outside combustion air is required, air may be drawn from the outdoors via a duct connected directly to the burner intake. The duct shall be constructed of galvanized steel or a material having equivalent strength and rigidity. Refer to the burner manufacturer's recommendations and installation instructions for additional guidelines and application requirements.

2.12.4 Combustion Air from an adjacent room

Where combustion air is to be used from within the building, air must be provided into the equipment room through two permanent openings into the interior building. Each opening must have a minimum free area of 1 square inch for each 1,000 Btu/hr of the total input rating of all fuel burning equipment in the space. The louvers shall be located as follows: top louver shall start within 12" of the ceiling and the bottom louver within 12" of the floor as prescribed in NFPA 54.

2.12.5 Condensate Removal

The exhaust vent pipe must be pitched at least 1/4" per foot of length back to the boiler. This will allow condensate to drain back to the unit to be disposed. Low spots in the venting where condensate may collect should be avoided. A plastic hose or PVC drain pipe may be used to discharge condensate to the neutralization system. Care should be taken to avoid kinks and from raising the drain line above the trap assembly.

2.13 Door hinges

The boilers are pre-fitted with three hinges so that the direction of opening of the door can be rapidly reversed.

Once you have checked that the default direction of opening is as required, or have reversed the direction of opening as instructed in the 'Changing the direction of door opening' section, remove the spare hinge assembly 'B' (screw, bushing and washer) opposite the pivot side of the door.

Two different door hinge systems have been used to meet different design requirements

System A

(on the smaller sizes) - comes with a bracket and two hinge fixing nuts.

System B

(on the larger sizes) - comes with a hinge fixing plate, a nut and an internal compression spring.

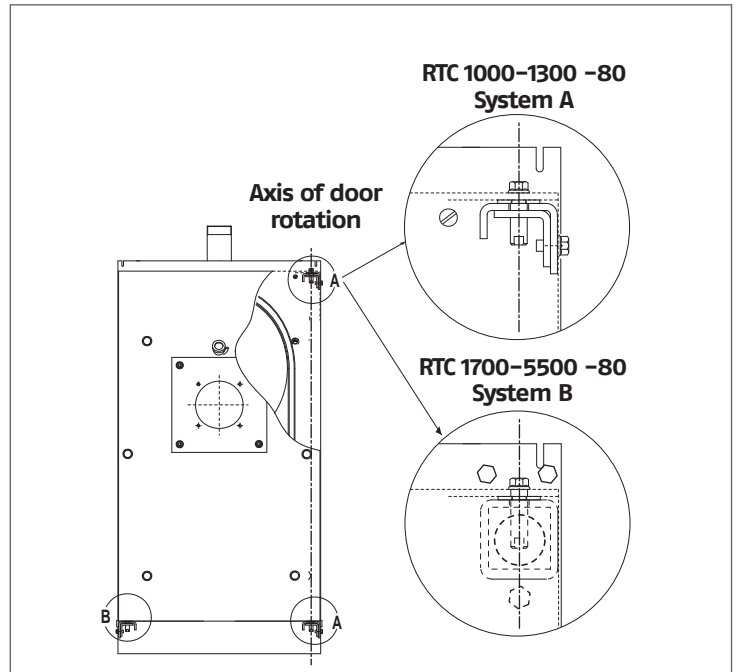

2.14 Changing the direction of door opening

The boiler door hinges are fitted on the right of the door at the factory. If you need to reverse the direction of opening, remove the boiler's side panel and proceed as follows:

RTC 1000-1300 -80

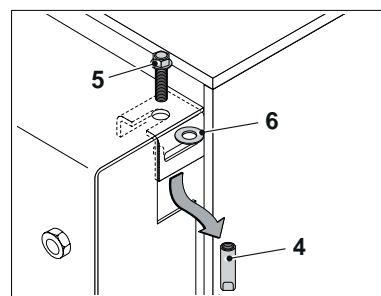
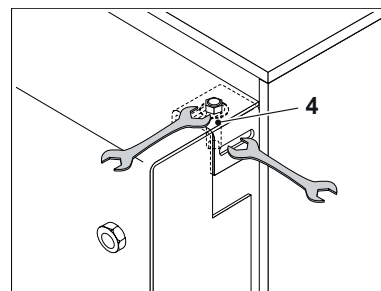
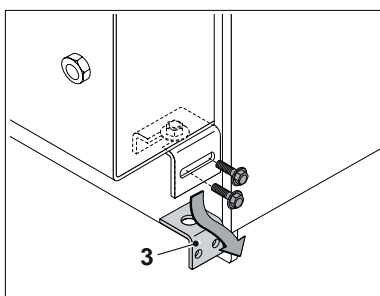
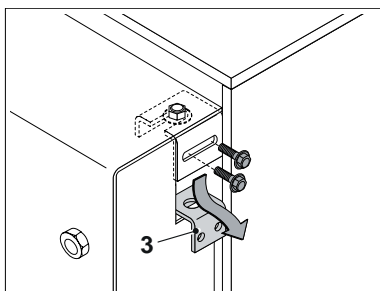
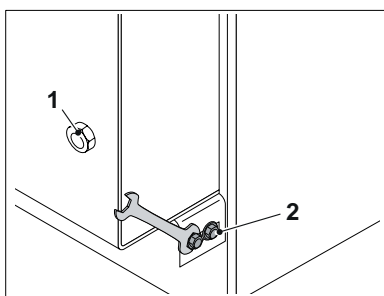
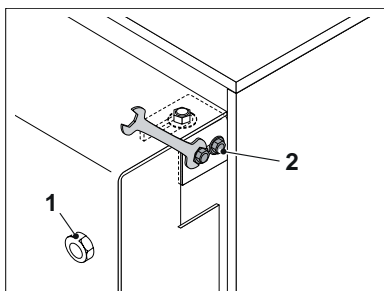

- Check that the main door fixing bolts (1) are tight and then remove the safety bolts (2).

- On the side opposite of the door, fit the bush (4), screw (5) and washer (6) that were just removed.

- And lift off the door fixing brackets (3)

- Insert a spanner through the top side slot and hold the bushing (4) steady.
- Unscrew the top screw (5), then remove the bushing (4) and washer (6).

⚠ If there are difficulties concerning door alignment and height when inserting the pin lock (4-5-6), loosen the locking screws (1) only slightly and lift the door to make it easier to insert the washer (6).

⚠ The door must be lifted using equipment suitable for its weight and using suitable safety protections. Once the washer (6) is inserted, position the screw and bush, then tighten them.

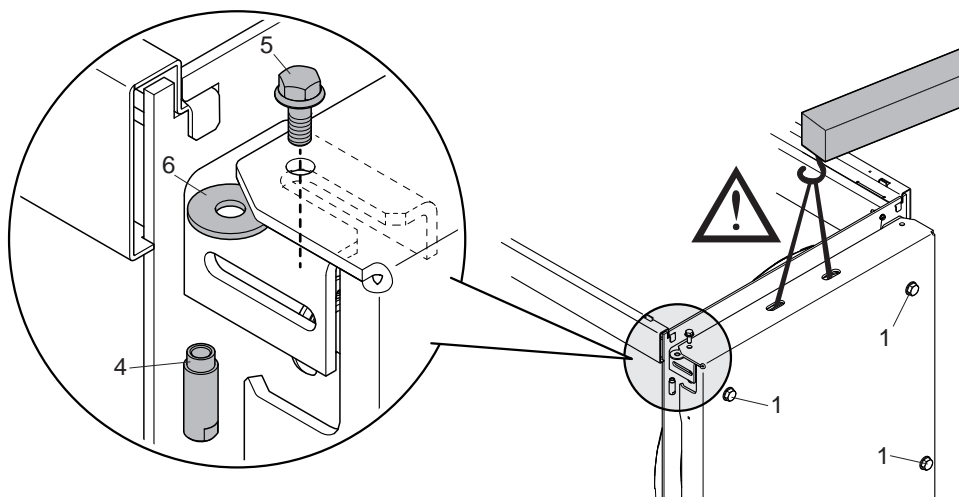

Reverse the above steps to fit the door on the opposite side.

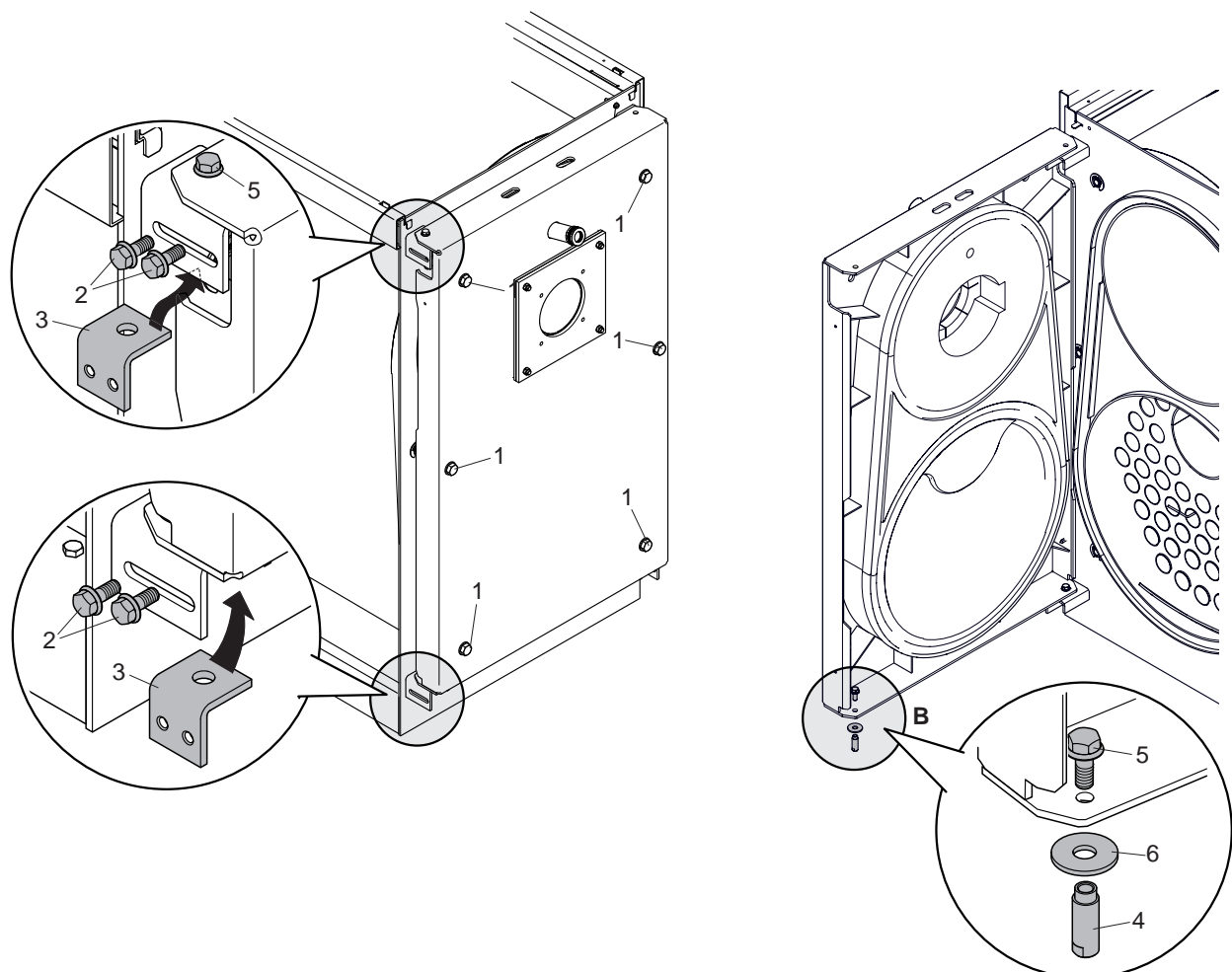

- Refit the previously removed upper door stop bracket (3) on the side opposite of the original position, blocking it with the safety screws (2).
- Refit the previously removed lower door stop bracket (3) on the side opposite of the original position, blocking it with the safety screws (4).

- Completely loosen the self-sustaining locking screws (1) for the structure, and open the door.
- Remove the pin group "B" (screw (5), bush (4), washer (6)) located on the side opposite of the door rotation axis.

⚠ Before opening the door, make sure that the safety screws (2) and (5) are well tightened and locked.

RTC 1700-5500 -80

- Use a blade or alternative saw edge to remove the pre-cut parts (A) at the front end, on the opposite side to the door hinges.
- If necessary, unscrew the screws (1) and open the door to do this from the front.

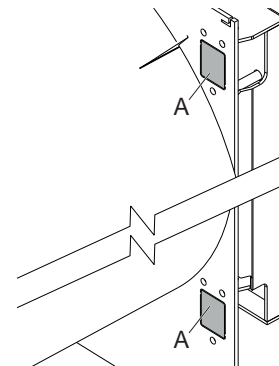
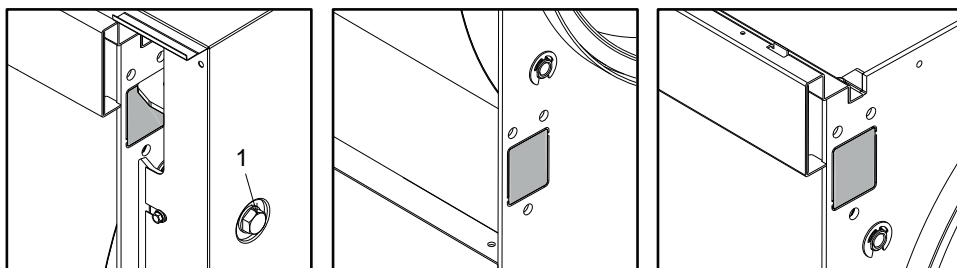

- Close the door and secure it with the screws (1).
- Remove the plug (2) in the upper and lower hinge, paying attention to the pressure of the spring (3) inserted inside.
- Remove the screws (4).
- Tighten the adjustment pin (5) to lower it.
- Remove the bolts (6) and slide out, from the inside, the hinges (7) supporting the door.

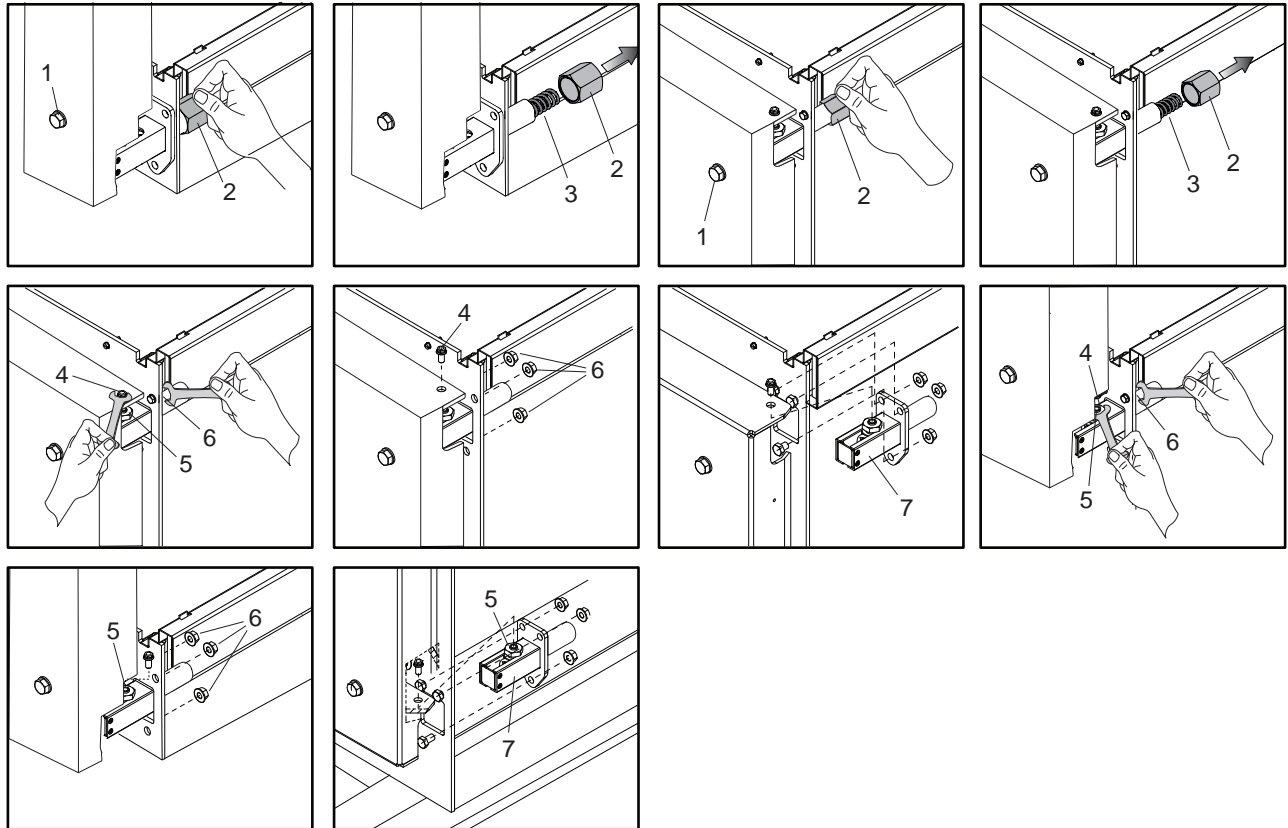

- Restore opening on the other side by repeating the sequence in reverse order.

Take care when assembling the adjustment pin:

- Unscrew the adjustment pin (5) to lift it.
- Check the pin groove (5) is slotted correctly into the door hole.
- Tighten the screws (4) and block them.
- Unscrew the screws of the door (1) and check that it opens/closes correctly.

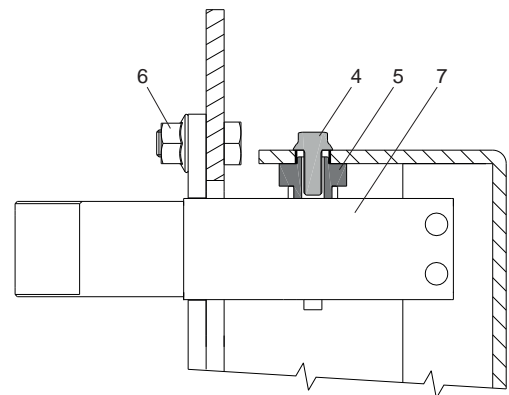

2.15 Removing the hinge assembly "B"

System A

- First ensure that the side safety bolt (2) is tight and then remove the main fixing bolt (1)

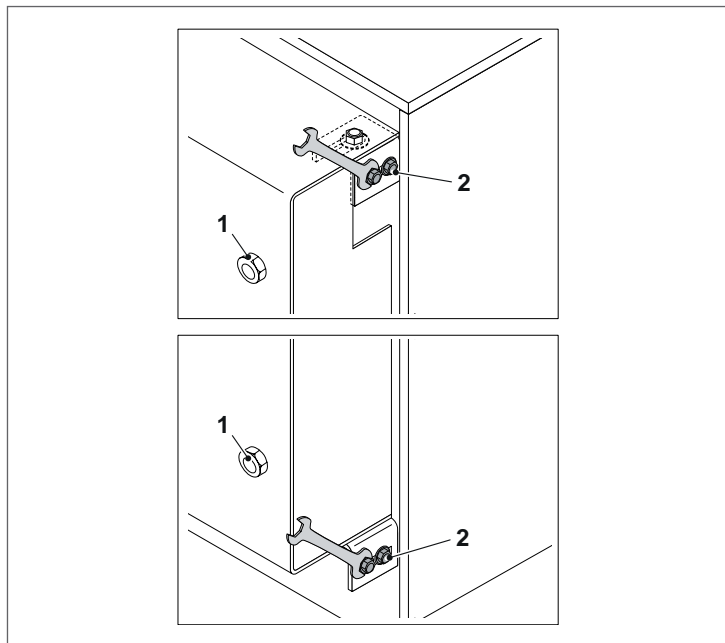

- With the door open, remove the hinge assembly 'B' (bushing, bolt, and washer) opposite the pivot side of the door.

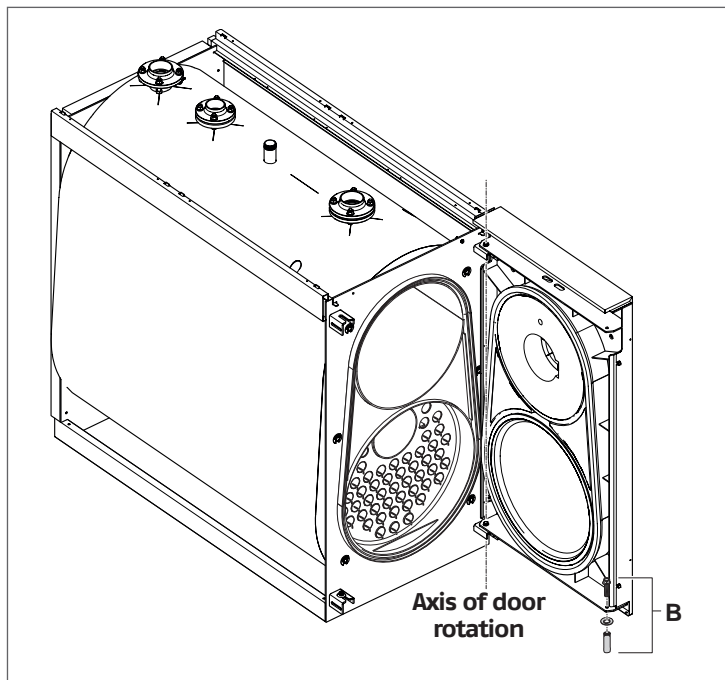

2.16 Earth connection

A terminal is provided on the front boiler head to connect the boiler body to an efficient earth system.

Proceed as follows:

- Unscrew the nut and washer (1) from the earth terminal
- Attach the earth cable's eye connector (2) to the terminal. (Make sure that the cable is of adequate size and complies with legislation in the country of installation)
- Fit the nut and washer (1) to the earth terminal and tighten the nut
- Connect the other end of the cable to the system's earth ground.

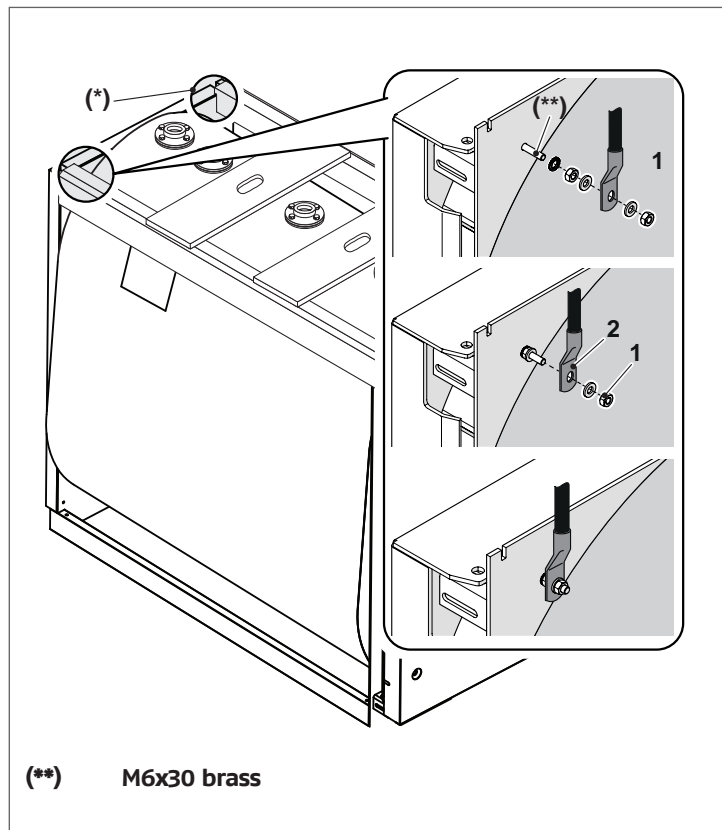

- ⚠** Another hole (*) in the left side of the boiler head can also be used to ground the appliance. If you wish to use this hole for the earth connection, remove the terminal fittings from the right of the head and move them to the left grounding point.

2.17 Fitting the casing panels

Proceed as follows to fit the boiler casing panels:

Attach the front side panels ((2) and (3)) and rear side panels ((4) and (5)) over the boiler frame (1) and to the top side beams.

On models RTC 1700-5500 -80 also fit side panels (6) and (7).

- Secure the side panels in place using the top cross beams (8) and the screws provided

- Fit the top rear panel (9), the bottom rear bracket (10) and then the bottom rear panels (11) and (12).
- Fit the front top panel (13)
- Fit the top panels (14), (15), (16) and (17)
- Smaller models have only two top panels, one over the right and one over the left of the boiler
- Finally, fit the front trim panels (18) and (19).

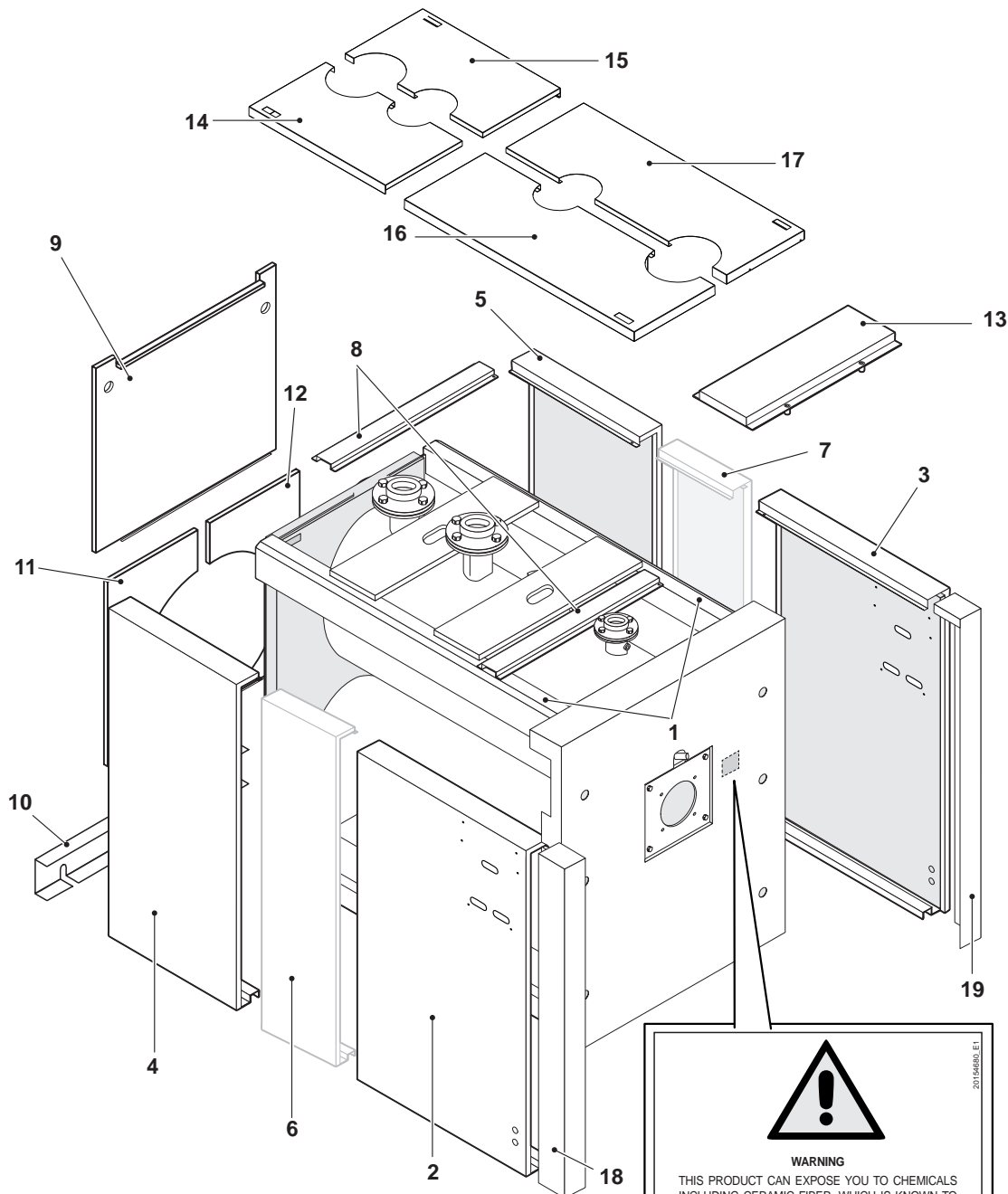



WARNING

THIS PRODUCT CAN EXPOSE YOU TO CHEMICALS INCLUDING CERAMIC FIBER, WHICH IS KNOWN TO THE STATE OF CALIFORNIA TO CAUSE CANCER. FOR MORE INFORMATION GO TO www.P65Warnings.ca.gov

20146800_EU

3 COMMISSIONING

3.1 Preparing for initial startup

⚠ NOTICE: Risk of boiler damage through contaminated combustion air.

- Never operate the boiler in very dusty conditions, e.g. if building work is taking place in the installation room.
- Ensure adequate ventilation.
- Never use or store chlorinated cleaning agents or halogenated hydrocarbons (as contained in spray cans, solvents or cleaning agents, paints and adhesives, for example) in the boiler room.
- A burner contaminated during building work must be cleaned before commissioning.
- All cover plates, enclosures, clean out ports, and guards must be in place at all times, except during maintenance and servicing.
- Never burn garbage or paper in the unit, and never leave combustible materials around it.

It is essential to perform the following checks before starting up or testing the functioning of your **RIELLO RTC-80** boiler. In particular, check that:

- the turbulators (2) are correctly positioned (vertical position) inside the heat exchanger tubes and the clips (3) are resting against the wall (4) of the heat exchanger

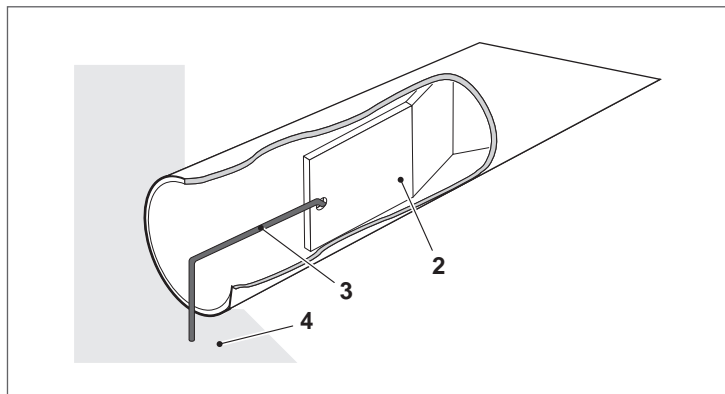

- The water and gas cocks are open

- The expansion vessel is properly charged



- The working pressure in the heating circuit is **over 1 bar** but below the maximum limit specified for the boiler
- The water circuits have been properly bled

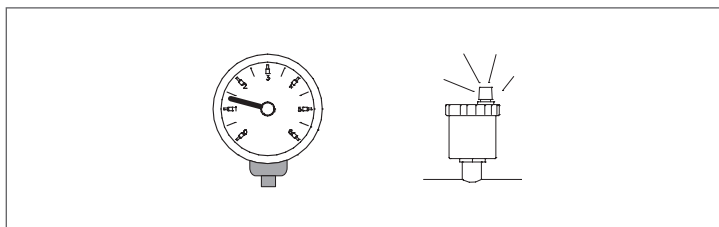

- The condensate discharge siphon has been filled with water
- The mains power connections to the boiler and its accessories (burner, pump, control panel, thermostats, etc.) have been properly made.

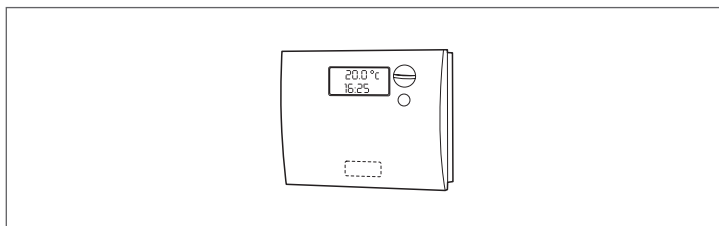

⚠ The phase-neutral polarity has been respected.

⚠ A ground (earth) connection is obligatory.

3.2 Third party control units

Control panels are not supplied.

⚠ NOTICE: System damage due to incorrect sensor position!
Safety cut-out and thermostat sensors of third party control units must be fitted in the instrument tapping of the outlet of the boiler.

- The third party control unit (building management system or PLC controllers) must ensure a maximum internal boiler water temperature that is sufficiently different from the high limit safety cut-out. It must also be ensured that the digital burner controller rather than the boiler water temperature regulator switch the burner on and off.
- The control unit must ensure that the burner is switched to low fire before being shut down.
- Select control equipment that allows a gentle start-up with a time delay when the system is cold.
- After the burner demand, an automatic timer (for example) should limit the burner to low fire for a period of approx. 180 seconds. This restricted heat demand will prevent uncontrolled starting and stopping of the burner.
- It must be possible to show the number of burner starts on the control unit used.

3.3 Hydraulic connection to the heating system

- If the system temperatures are different, use both return connectors high temperature and low temperature. For an optimum energy yield, we recommend supplying a flow rate of > 10 % of the total nominal flow rate via the low temperature flange, with a return temperature below the dew point. If there are no varying return temperatures, only the low temperature flange needs to be connected.
- Size the pumps correctly. High flow rates and oversized pumps can result in the accumulation of sludge or deposits on the heat exchanger surfaces.
- Before connecting the boiler, flush sludge and dirt out of the heating system.
- Ensure that no oxygen enters the heating water during operation.
- Only operate the boiler in sealed unvented systems.

3.4 Making the electrical connection

- ⚠ DANGER:** Danger to life through electric shock!
- Before opening the boiler, isolate the heating system across all live phases and secure against unintentional reconnection.
 - Carefully route the cables/leads and capillary tubes.
 - Ensure that capillaries are never kinked.
 - Only carry out electrical work if you are a competent person. If you are not suitably qualified, arrange for a qualified electrician to make the electrical connections.
 - Observe local installation regulations.
 - Create all electrical connections in accordance with National Electrical Code or the applicable and local regulations.

- ⚠ NOTICE:**
- The phase-neutral polarity must be respected.
 - **A ground (earth) connection is obligatory.**

Wiring diagrams related to the burner installation may be found in the burner installation manual.

3.5 Fitting temperature sensors

- ⚠ NOTICE:** System damage through damaged capillaries or incorrectly fitted temperature sensor.
- Ensure that the capillaries are neither kinked nor flattened when uncoiling and routing them.
 - Always push the temperature sensor completely into the bottom of the sensor well.
 - **Insert the temperature sensor set as far as it will go into the test point (to the bottom).** Mark the sensor to determine if it is correctly installed.
 - Secure the temperature sensor set in the test point with a sensor retainer.
 - Never kink excess lengths of capillaries.
 - Route the sensor lead through the cable conduit to the control unit.
 - Connect the sensor lead to the control unit.
 - Complete the commissioning report.

3.6 Flushing the heating system

If the heating system contains several heating circuits, these must be flushed one after the other.

To prevent contamination in the boiler, flush the heating system prior to commissioning.

- Flush the system prior to connection to the boiler. Isolate the heating supply and return at the boiler.
- Connect the heating supply to a water connection.
- Connect hose to the heating return of the heating system.
- Route hose from the heating return to a drain.
- Open connected consumers (e.g. radiators).
- Flush the heating system with fresh water until clear water emerges from the heating return.
- Drain the heating system.

3.7 Filling the heating system

⚠ CAUTION: Health risk through contaminated drinking water.

- Observe all country-specific regulations and standards regarding the prevention of drinking water contamination.

⚠ NOTICE: System damage through temperature stresses.

- Only fill the heating system when cold (the water supply temperature must not exceed 104 °F (40 °C)).
- During operation, only fill the heating system via the fill valve in the heating system pipework (return).

Open the automatic air vent valve only briefly for venting.

The fill and top-up water quality must comply with the water requirements in this manual.

The pH value of the heating water increases after the heating system has been filled. After 3 – 6 months (initial service) check whether the pH value of the heating water has settled down.

- Adjust the pre-charge pressure of the expansion vessel to the required pressure (only for sealed unvented systems).
- Open the shut-off valves on the heating water side.
- Fill the heating system slowly and observe the pressure gauge whilst doing so.
- Vent the heating system via the radiator air vent valves.

If the water pressure drops as a result of venting the system:

- Top up the system with water.
- Carry out a leak test in accordance with locally applicable regulations.
- After the tightness test, reinstate all components that were taken out of operation.
- Ensure that all pressure, control and safety equipment is functioning correctly.

Once the boiler has been tested for tightness and no leaks have been found:

- Set the correct operating pressure. The working pressure in the heating system should be over 14 PSI but below the maximum limit specified for the boiler.
- Close the automatic air vent valve.

3.8 Preparing the heating system for operation

Observe the following points during commissioning:

- Before commissioning, vent the heating system via the ventilation facilities provided for this purpose.
- Check that the inspection opening on the flue gas collector is closed.
- Check that the combustion chamber door is securely closed.
- Check that the safety equipment (e.g. safety valve, minimum and maximum pressure limiters, high limit safety cut-out) is functioning correctly.
- Check that the required operating pressure has been achieved.
- Check the flange connections and other connections for tightness.
- Check the control unit connections and temperature sensor positions.
- Fill the condensate siphon.

3.9 Commissioning the control unit and burner

By commissioning the control unit you automatically commission the burner as well. The burner can then be started by the control unit. For further information, see the installation instructions of the relevant control unit or burner.

- Use the control unit to commission the boiler.
- Set the control unit parameters.
- Complete the commissioning report in the technical documentation of the burner.

3.10 Commissioning report

The boiler can be operated with a gas or dual fuel burner.

- Carefully complete the commissioning report for the relevant approved burner.
- Sign all completed commissioning work and enter the date.

COMMISSIONING STEPS	COMMENTS (SIGNATURE)
Flush the heating system.	
Fill the heating system with water.	
Vent the heating system.	
Carry out tightness test.	
Switch on the control unit. -Boiler-specific parameters set and recorded.	
Ensure the function of all safety equipment.	
Check the fuel line for tightness.	
Start the burner.	
Complete the burner test report regarding the individual output stages.	
Conduct a tightness test on the hot gas side. After a short time in operation, tighten the screws in the combustion chamber door to prevent leakage around the door as a result of the packing cord settling.	
Check the flange connections and fittings after the boiler has been heated up and retighten.	
Check flue path for tightness.	
Check the flue gas temperature.	
Carry out a function test on all safety equipment and record this.	
Instruct the system user and hand over technical documentation.	
Enter the fuel used in the table (See "General" operating instructions)	
Confirm commissioning by a competent person. Company stamp/signature/date	

4 SHUTDOWN

⚠ CAUTION: Risk of system damage through frost.

When there is a frost, the heating system can freeze up if it is not operational, e.g. because of a fault shutdown.

- When there is a risk of frost, protect your heating system against freezing up.
- If your heating system has been shut down for several days due to a fault shutdown and there is a risk of frost, drain the heating water at the drain & fill valve. Also leave the air vent valve at the highest point in the system open.

⚠ NOTICE: Risk of system damage through frost.

The heating system can freeze up as a result of a power failure or if the power has been switched off.

- Check the "Control unit settings" to ensure the system remains operational (especially when there is a risk of frost).

⚠ NOTICE:

- Always keep the oil supply valve shut off if the burner is shut down for an extended period of time.

4.1 Shutting down the heating system

Shut down your heating system via the control unit. Switching off the control unit also switches off the burner automatically.

- Set the On/Off switch of the control unit to Off.
- Isolate the fuel supply to the burner.

4.2 Shutting down the heating system in an emergency

Only in emergencies, switch OFF the heating system via the boiler room breaker or the heating system emergency stop switch.

- In dangerous situations, immediately close the main fuel shut-off valve and the power supply of the heating system via the boiler room main breaker or the heating system emergency stop switch.
- Isolate the fuel supply to the burner.
- Never put your life at risk. Your own safety is paramount.

5 INSPECTION AND MAINTENANCE

5.1 Why is regular maintenance important?

Heating systems require regular maintenance and service for the following reasons:

- to maintain a high level of efficiency and to operate the system economically (low fuel consumption),
- to achieve a high level of operational reliability
- to maintain the cleanest possible combustion

The operator is required to have the entire heating system at least once a year maintained, serviced and cleaned.

We recommend that an annual inspection and as-required service contract is signed.

The servicing work carried out should be recorded.

Burner servicing should be carried out in accordance with the instructions of the burner manufacturer.

5.2 Maintenance

Regular maintenance is a legal requirement. It is also essential for the safety, efficiency and durability of the boiler. Proper maintenance keeps consumption and emissions down, and ensures that the boiler continues to operate reliably over time.

Have your boiler serviced either by **RIELLO's** Technical Assistance Service or by a qualified heating engineer. Analyze the combustion exhaust gases before commencing any maintenance. The results of the flue gas analysis can give a clear idea of what servicing or repairs are needed.

- Turn the system's main power switch OFF
- Close all the gas cocks.

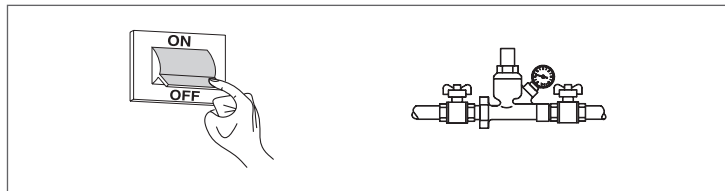

⚠ DANGER: Risk to life from electric shock!

- Before opening a unit: disconnect electrical power and lockout to prevent accidental reactivation.

⚠ DANGER: Risk to life from explosion of flammable gases!

- Work on gas components must only be carried out by qualified and authorized gas fitters.

⚠ NOTICE:

- All cover plates, enclosures, and guards must be in place at all times, except during maintenance and servicing.

Analyze the combustion flue gas before commencing any maintenance.

The results of flue gas analysis can give a clear idea of what servicing or repairs are needed.

OPENING THE DOOR

System A

- Make sure that the safety bolts (1) on the side of the boiler are tight.

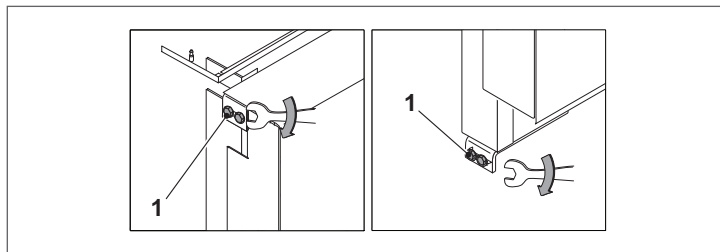

System A - B

- To open the door, simply remove the main fixing bolts (2) under the caps (3) holding the door in place.

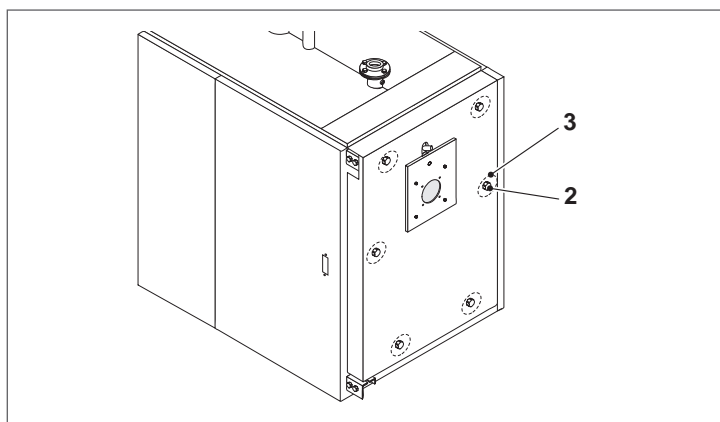

ADJUSTING THE DOOR

Make quite sure that the door presses uniformly all around the double seal to prevent dangerous fumes escaping into the air from the pressurized furnace. Proceed as follows to adjust the door seals:

System A

- Fit the door and tighten the main fixing bolts (2) until the seals start to compress
- Loosen the safety bolts (1) then fully screw in the main door fixing bolts (2)
- Make sure that the door is properly adjusted after every maintenance operation.

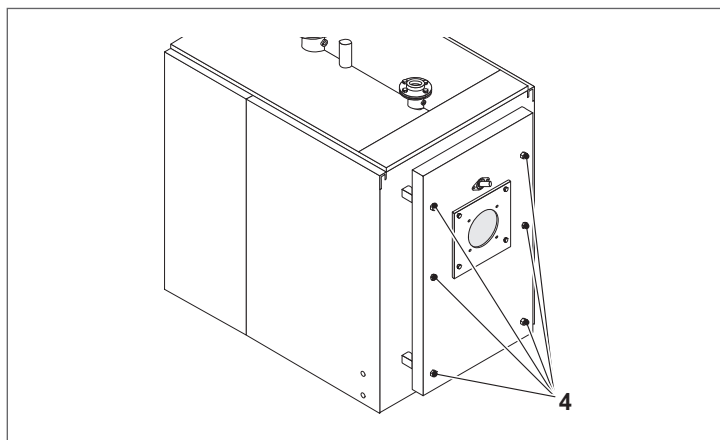

System B

- Put the door in its correct position and tighten the main locking screws (4) until the packing starts to be compressed.

⚠ Make sure that the door is properly adjusted after every maintenance operation.

5.3 Cleaning the boiler

Clean the boiler and remove any carbon deposits from the surfaces of the heat exchanger **at least once a year**. This not only extends the boiler's working life, but also keeps it efficient in terms of heat output and fuel consumption.

Proceed as follows to clean the boiler:

- Open the front door (1) and remove turbolators (2)
- Use a flue brush (3) or other suitable tool to clean inside the combustion chamber and the flue gas pipes

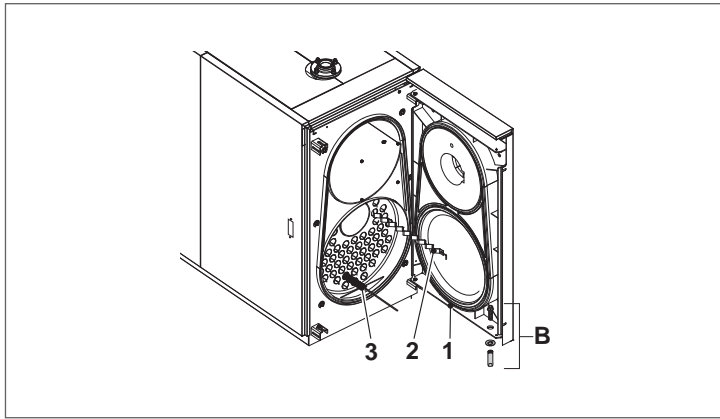

⚠ The first time opening the door, remove the spare hinge assembly (B) (bushing, bolt, and washer) opposite the pivot side of the door.

Remove the deposits accumulated in the flue box through the opening of the inspection door (4).

If more thorough cleaning is required, remove the outer panels, unscrew the eight fixing bolts (5) and pull firmly on the flue gas box (6) to remove it from the boiler.

Check at regular intervals that the condensate drain (7) is not blocked.

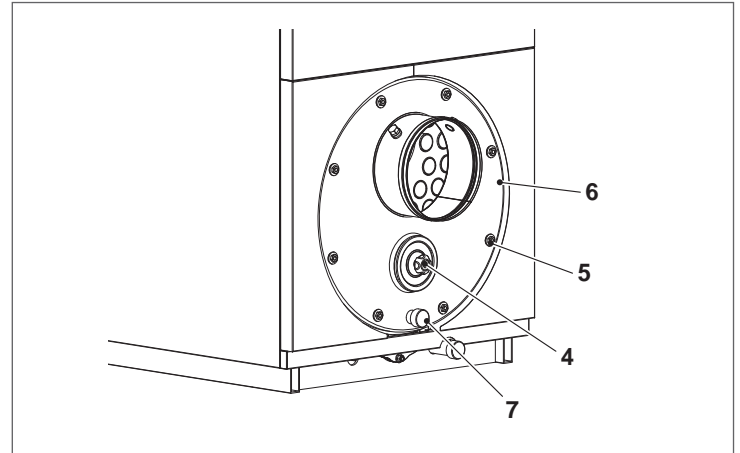

If necessary, replace the seal (8).

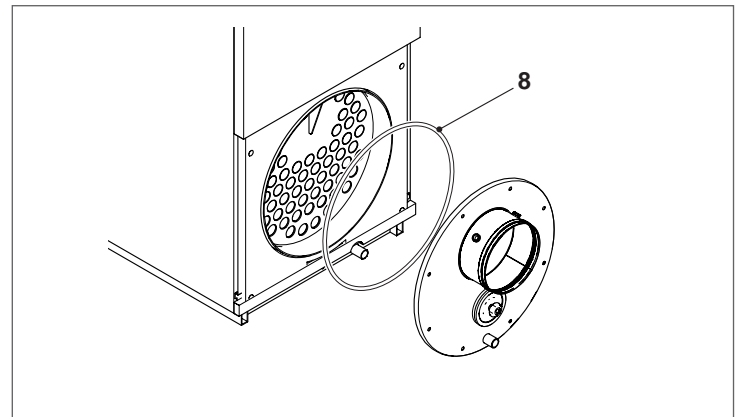

On completion of cleaning, follow the above steps in the reverse order to refit all removed parts.

Use a tightening force of 8 Nm/6 ft-lbs on the retaining nuts.

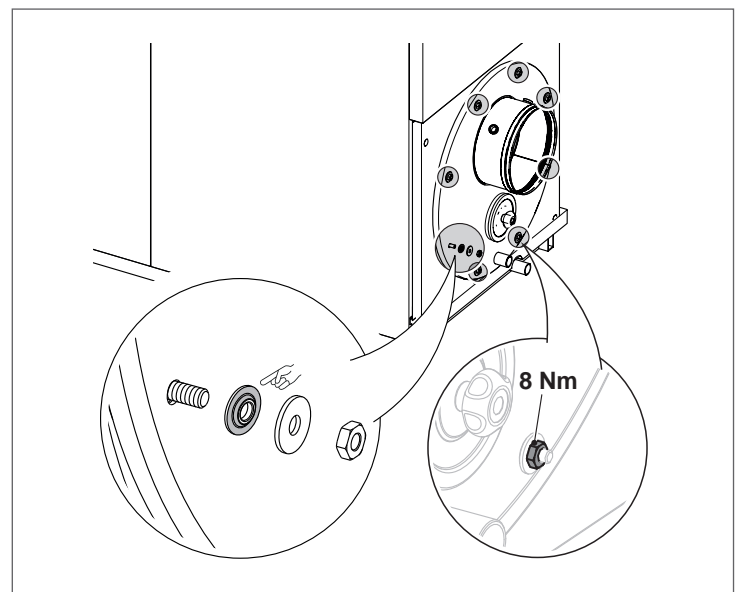

5.4 External cleaning

Clean the outside of the boiler casing with a soft cloth dampened with soapy water.

To remove stubborn marks, use a cloth dampened in a 50% mix of water and denatured alcohol or a suitable cleaning product. Dry the boiler after cleaning it.

⊖ Do not use abrasive products, petrol or triethylene.

5.5 Checking and correcting the water pressure

The heating system must contain sufficient water to safeguard its correct function.

- If the water pressure in the heating system is too low, top up with water.

When should you check the water pressure in the heating system?

The fill and top-up water quality must comply with the water requirements in this manual.

Air pockets may form in the heating system from gases released by the fill and/or top-up water.

- Vent the heating system (e.g. bleeding the radiators).
- If required, top up with water

Recently added fill or top-up water loses much of its volume in the first few days because it releases gases. With new systems you should therefore initially check the heating water pressure on a daily basis, and thereafter at gradually longer intervals.

Once the volume of the heating system has stabilized, check the heating water pressure monthly.

A distinction is generally made between open vented and sealed unvented systems. In practice, open vented systems are hardly installed nowadays. We will therefore be using a sealed unvented heating system to demonstrate how you can check the water pressure. All settings will have already been made by the installation engineer when the system was first commissioned.

Sealed unvented systems

⚠ NOTICE: System damage through frequent topping up. Subject to the water quality, your heating system can be damaged through corrosion or scaling.

- Ensure that the heating system is vented correctly.
- Check the heating system for leaks and the expansion vessel for functionality.
- Observe the requirements regarding water quality.
- If water loss occurs frequently, locate the cause and rectify the problem without delay.

⚠ NOTICE: System damage through temperature stresses.

- Only fill the heating system when cold (the system flow temperature must not exceed 104 °F (40 °C)).
- During operation, only fill the heating system via the fill valve in the heating system pipework (return).

For sealed unvented systems, the pressure gauge needle should be near the mid point of the gauge. The red needle of the pressure gauge must be set to the pressure required for the heating system.

- Check the heating system water pressure.
- Top up with water via the filling valve in the heating system pipework.
- Vent the heating system.
- Check the water pressure once more.

5.6 Boiler inspection - water-side

Carrying out the inspection is important in order to check the condition of thermal exchange surfaces and the presence of sludge or lime scale.

The boiler's inner can be inspected through dedicated openings

⚠ The inspection must be carried out with the boiler in the off position, in safe mode and cold (room temperature), with all system shut-off valves closed except the discharge valve.

In order to inspect the upper part of the boiler, partially empty the boiler before opening inspection openings.

Inspection openings are located in the following areas:

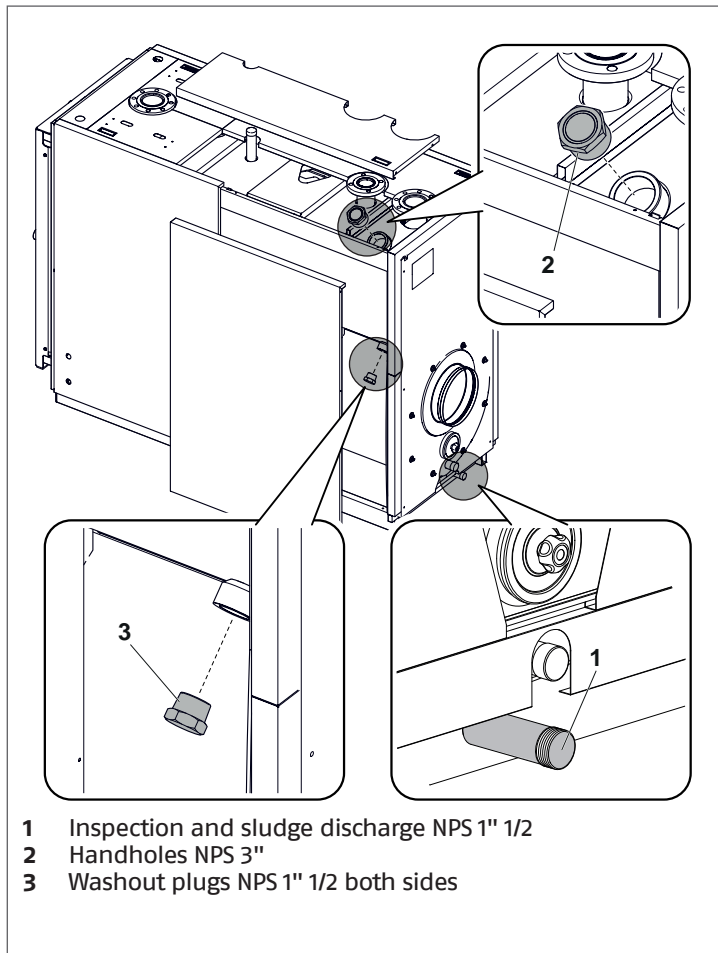

The boiler must be fully emptied if it is necessary to access the discharge outlet (1).

Check the integrity of the seals and close inspection openings by tightening the cross-head screws.

Fill the system and check the pressure as detailed in paragraph "Checking and correcting the water pressure".

5.6.1 Inspection and maintenance reports

The inspection and maintenance reports provide an overview of the required inspection and service steps that should be carried out annually.

Warranty:

- Annual inspection and service are part of the warranty terms.

Complete these reports after inspections and service. The report can also be used as copying template:

- Sign and date the completed inspection work.

INSPECTION WORK	REFERENCES	NOTES
Check the general condition of the heating system (visual inspection).		
Check the heating system function.		
Check the components in contact with fuel and water throughout the system for the following: -Tightness -Visible signs of corrosion -Signs of aging		
Check the combustion chamber and heating surface for contamination and clean them. For this, shut down the heating system.	See spec. chapter of this manual	
Check gaskets/packing cords on combustion chamber door and replace if required.		
Check and clean the burner: -Visual inspection and remove any contamination. -Check all safety equipment (safety shutdown). -Function check -Flue gas analysis with test report for each output stage.	See technical burner documentation.	
Check the flue for function and safety.	See flue manufacturer documentation.	
Check the hydraulic seal of the condensate siphon and replace if required.		
Check the water pressure and pre-charge pressure of the expansion vessel.	See spec. chapter of this manual	
Confirm the control unit settings are suitable and adjust if required.	See technical control unit	
Test all safety equipment (safety shutdown) and record findings. For example: -High limit safety cut-out -Minimum limiter pressure -Maximum limiter pressure (if installed) -Other safety equipment.		
Conduct a water analysis and record the results in the operator's log: -pH value -Residual hardness -Oxygen binder -Phosphate -Electrical conductivity -Appearance -Check water records (e.g. amount of make-up water) in the operator's log.		
Check the neutralization system.		
Final check of the inspection work, take measurements and record values and test results.		

5.7 Troubleshooting

PROBLEM	CAUSE TROUBLESHOOTING	TROUBLESHOOTING
The boiler does not reach its set temperature.	Heat exchanger dirty.	- Clean the flue gas pipes.
	Heat exchanger and burner mismatched.	- Check specifications and settings.
	Insufficient burner gas flow.	- Check and adjust the burner.
	Control thermostat problem.	- Check the functioning of the aquastat. - Check the temperature setting.
The boiler keeps shutting down, and the control panel warning light comes on.	Control thermostat problem.	- Check the functioning of the aquastat. - Check the temperature setting. - Check the electrical wiring. - Check the sensor bulbs.
	No water supply.	- Check the circuit pressure.
	Air in the circuit.	- Check the vent valve.
	Air in the circuit.	- Bleed the circuit.
The boiler has reached the set temperature but the radiators are still cold.	Pump malfunctioning.	- Check/release the pump.
	Problem with minimum temperature aquastat (if present).	- Check the temperature setting.
There is a smell of exhaust fumes.	Fumes are escaping into the air.	- Check that the boiler body is clean. - Check that the flue pipes are clean. - Check that the boiler, flue pipes and flue gas exhaust stack are all properly sealed.
	Excessive pressure in the circuit.	- Check the circuit pressure. - Check the functioning of the pressure reducer. - Check the settings of the pressure reducer.
The safety valve keeps opening.	Problem with heating system expansion vessel.	- Check the efficiency of the expansion vessel.
	Flue gas box seals.	- Check the seals between the rear head and the flue gas box.

6 ENVIRONMENTAL PROTECTION/DISPOSAL

Environmental protection is one of the fundamental company policies of the Riello. We regard quality of performance, economy and environmental protection as equal objectives.

Environmental protection laws and regulations are strictly adhered to.

To protect the environment, we use the best possible technology and materials taking into account economic points of view.

Packaging

For the packaging, we participate in the country-specific recycling systems, which guarantee optimal recycling. All packaging materials used are environmentally-friendly and recyclable.

Old appliances

Old appliances contain resources that should be recycled.

The components are easy to separate and the plastics are marked. This allows the various components to be sorted for appropriate recycling or disposal.

RIELLO

RIELLO S.p.A.
Via Ing. Pilade Riello, 7
37045 - Legnago (VR) - Italy
www.rielloboilers.com

North America:
35 Pond Park Road
Hingham, Massachusetts
U.S.A. 02043

2165 Meadowpine Blvd.
Mississauga, ON L5N6H6
CANADA

www.rielloboilers.com

The manufacturer strives to continuously improve all products: appearance, dimensions, technical specifications, standard equipment and accessories are subject to change without notice.