

Catalogo ricambi
Catalogue pièces détachées
Spare parts catalogue
Ersatzteilkatalog
Onderdelenlijst
Catálogo de recambios

RIELLO

Sistemi a condensazione
Systemes à condensation
Condensing systems
Brennwertsysteme
Sistemas a condensación

COD.	MOD.	TYP.
20177312	ARRAY AR-1000 2.5	
20177313	ARRAY AR-1500 2.5	
20177314	ARRAY AR-2000 2.5	

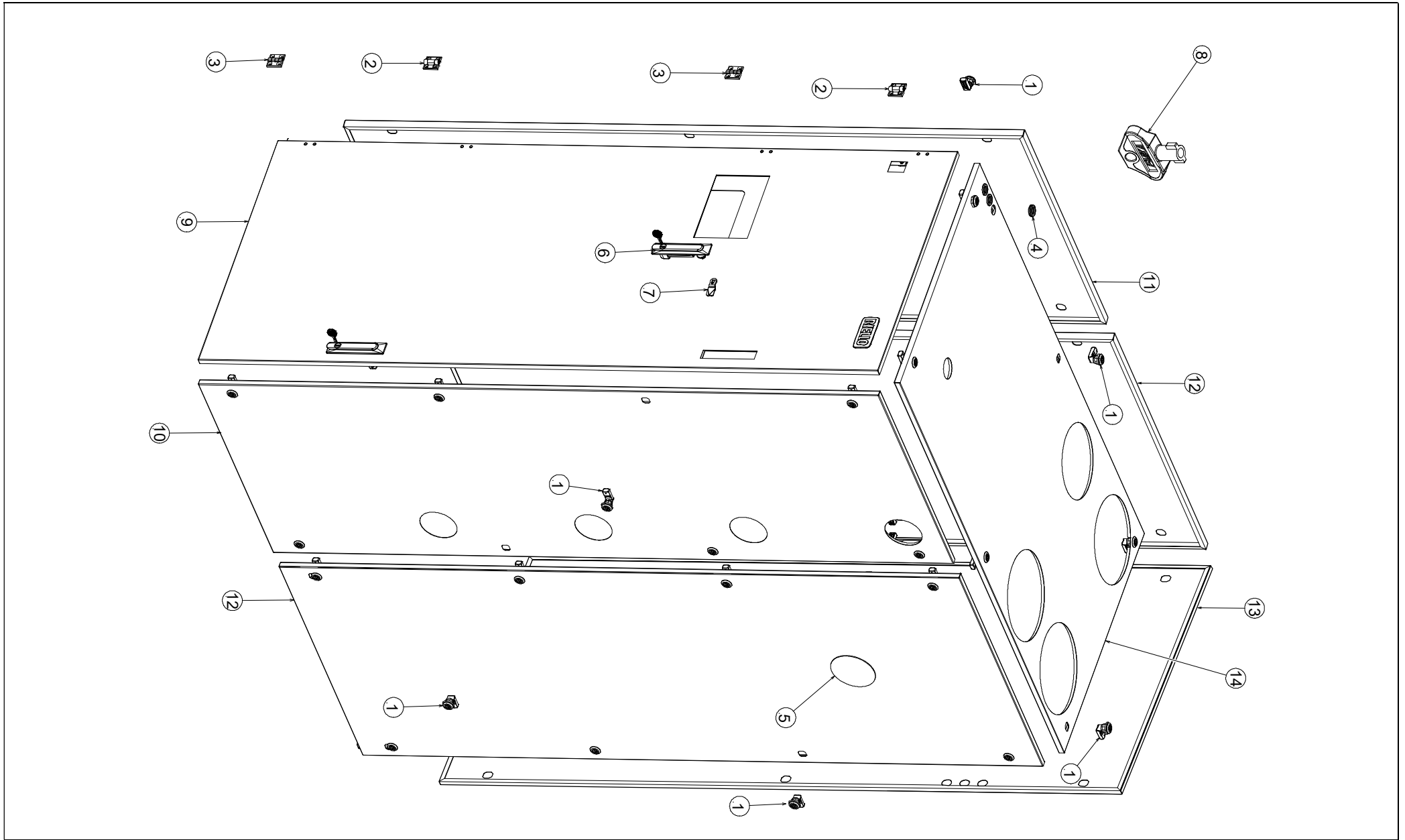

N.	COD.	RC	20177312	20177313	20177314	DESCRIZIONE	DESCRIPTION	DESCRIPTION	BESCHREIBUNG	BESCHRIJVING	DESCRIPCIÓN
1	20120175		•	•	•	Chiusura	Fermeture	Closure	Schliesselement	Sluiting	Cierre
2	20160055		•	•	•	Cerniera	Charniere	Hinge	Scharniereinheit	Scharnier	Cable señal PWM
3	20120283		•	•	•	Cerniera	Charniere	Hinge	Scharniereinheit	Scharnier	Cable señal PWM
4	20120288		•	•	•	Gommino	Silent blok	Grommet	Gummi	Rubber	Tapón de goma
5	20120180		•	•	•	Copertura	Capot	Cover	Abdeckung	Kap	Tapa (cubierta)
6	20120173		•	•	•	Chiusura a leva regolabile	Fermeture à levier réglable	Adjustable lever closure	Schliesselement mit variablem Hebel	Sluiting verstelbare hendel	Cierre a leva regolabile
7	20127231		•	•	•	Linguetta	Languette	Tongue	Feder	Veer	Linguete
8	20120328		•	•	•	Chiave	Clé	Key	Schlüssel	Sleutel	Llave
9	20139089		•	•		Sportello	Volet	Door	Klappe	Flap	Solapa
9	20139115				•	Sportello	Volet	Door	Klappe	Flap	Solapa
10	20139084		•			Pannello destro	Panneau de droite	Right panel	Rechte Tafel	Rechterpaneel	Panel derecho
10	20139051			•		Pannello destro	Panneau de droite	Right panel	Rechte Tafel	Rechterpaneel	Panel derecho
10	20139073				•	Pannello destro	Panneau de droite	Right panel	Rechte Tafel	Rechterpaneel	Panel derecho
11	20139050		•	•		Pannello sinistro	Panneau de gauche	Left panel	Linke Tafel	Linkerpaneel	Panel izquierdo
11	20139079				•	Pannello sinistro	Panneau de gauche	Left panel	Linke Tafel	Linkerpaneel	Panel izquierdo
12	20139053		•	•		Pannello laterale	Panneau latéral	Lateral panel	Seitenpaneel	Zijpaneel	Panel lateral
12	20139080				•	Pannello laterale	Panneau latéral	Lateral panel	Seitenpaneel	Zijpaneel	Panel lateral
13	20167723		•	•		Pannello posteriore	Panneau arrière	Rear panel	Hinteretafel	Achterpaneel	Panel posterior
13	20167718				•	Pannello posteriore	Panneau arrière	Rear panel	Hinteretafel	Achterpaneel	Panel posterior
14	20203665		•	•		Pannello superiore	Panneau supérieur	Top panel	Obere Blende	Bovenpaneel	Panel superior
14	20203664				•	Pannello superiore	Panneau supérieur	Top panel	Obere Blende	Bovenpaneel	Panel superior

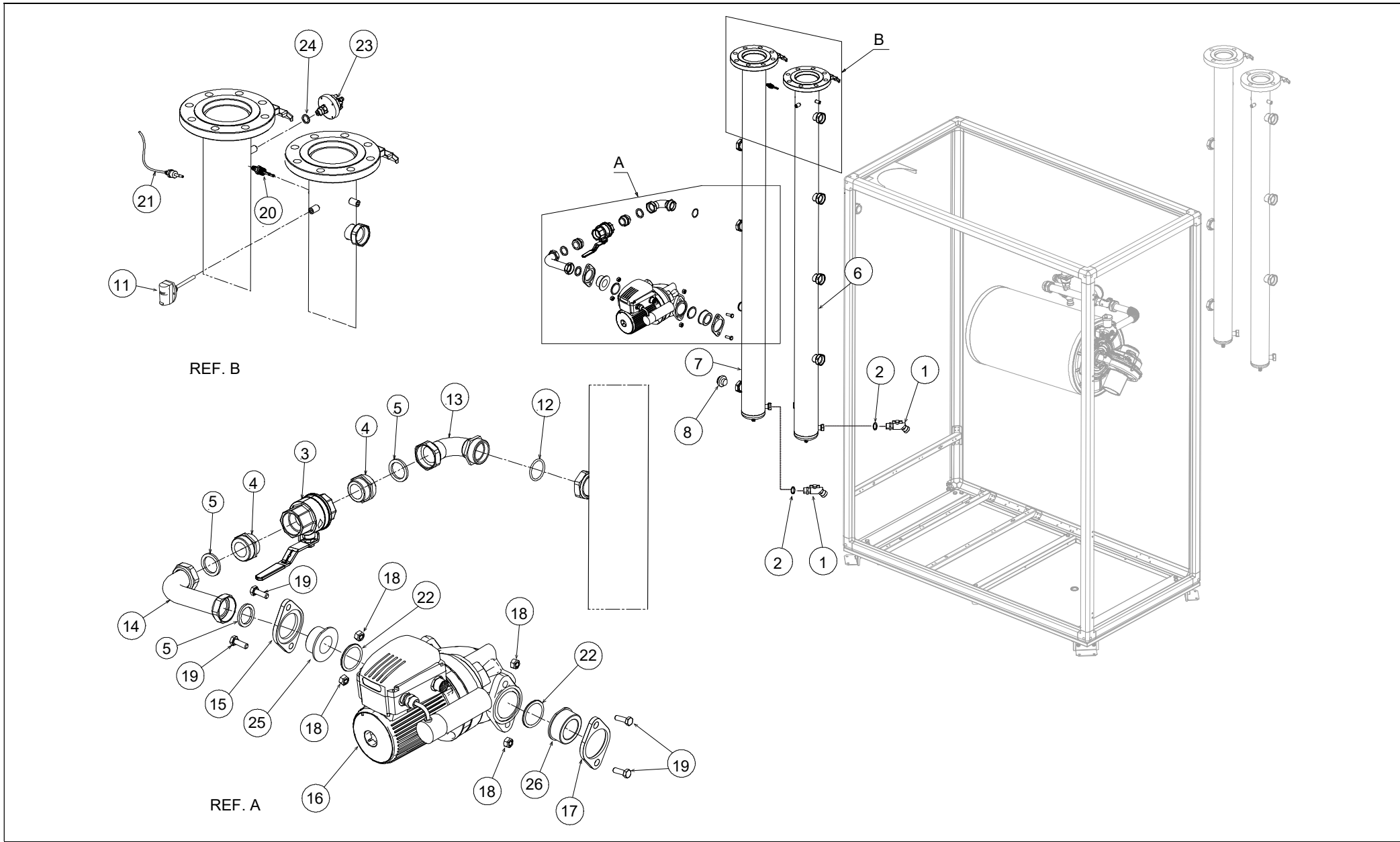

N.	COD.	RC	20177312	20177313	20177314	DESCRIZIONE	DESCRIPTION	DESCRIPTION	BESCHREIBUNG	BESCHRIJVING	DESCRIPCIÓN
1	20107403		•	•	•	Rubinetto	Robinet	Cock	Hahn	Kraan	Grifo
2	20120242		•	•	•	Guarnizione	Joint	Seal	Dichtung	Afdichting	Junta
3	20159961		•	•	•	Valvola idraulica	Groupe hydraulique	Hydraulic valve	Hydraulikventil	Watereenheid	Válvula hidráulica
4	20159960		•	•	•	Raccordo	Raccord	Connector	Anschluss	Aansluiting	Racor
5	20120250		•	•	•	Guarnizione	Joint	Seal	Dichtung	Afdichting	Junta
6	20160028		•	•		Collettore mandata	Collecteur départ	Delivery manifold	Vorlauf-Sammler	Toevoercollector	Colector de ida
6	20160000				•	Collettore mandata	Collecteur départ	Delivery manifold	Vorlauf-Sammler	Toevoercollector	Colector de ida
7	20160030		•	•		Collettore ritorno	Collecteur retour	Heating return manifold	Rücklauf-Sammler	Retourcollector	Colector de retorno
7	20159999				•	Collettore ritorno	Collecteur retour	Heating return manifold	Rücklauf-Sammler	Retourcollector	Colector de retorno
8	R.TAPPO074		•			Tappo	Bouchon	Plug	Verschluss	Dop	Tapón
9	20120243		•	•	•	Guarnizione	Joint	Seal	Dichtung	Afdichting	Junta
10	20120157		•	•	•	Pressostato acqua	Pressostat eau	Water pressure switch	Wasserdruckwächter	Waterdrukregelaar	Presostato de agua
11	20185568		•	•	•	Sonda ad immersione	Sonde en plongée	Immersion probe	Tauchfühler	Dompelvoeler sensor	Sonda de inmersión
12	20101600		•	•	•	Anello OR	Joint d'étancheité	O-ring	OR-Dichtung	Pakkingring	Anillo de cierre
13	20159939		•	•	•	Curva	Courbe	Bend	Bogen	Kromme	Curva
14	20180973		•	•	•	Tubo ritorno	Tuyau retour	Return pipe	Rücklaufrohr	Retourbuis	Tubo de retorno
15	20191431		•	•	•	Flangia	Bride	Flange	Flansch	Contraflens	Brida
16	20180975		•	•	•	Circolatore 115V	Circulateur 115V	Circulator 115V	Umlaufpumpe 115V	Circulatiepomp 115V	Circulador 115V
17	20191429		•	•	•	Flangia	Bride	Flange	Flansch	Contraflens	Brida
18	20120294		•	•	•	Dado	Écrou	Nut	Mutter	Moer	Tuerca
19	20180985		•	•	•	Vite	Vis sans fin	Screw	Schraube	Toevoerschroef	Perno
20	20116627		•	•	•	Sensore	Detecteur	Sensor	Fühler	Sensor	Revelador
21	20126743		•	•	•	Sonda temperatura	Sonde température	Temperature probe	Temperaturfühler	Temperatuur sensor	Sensor temperatura
22	20180816		•	•	•	Guarnizione pompa	Joint pompe	Pump seal	Pumpendichtung	Pomp pakking	Junta bomba
23	20120157		•	•	•	Pressostato acqua	Pressostat eau	Water pressure switch	Wasserdruckwächter	Waterdrukregelaar	Presostato de agua
24	20120243		•	•	•	Guarnizione	Joint	Seal	Dichtung	Afdichting	Junta
25	20180515		•	•	•	Raccordo	Raccord	Connector	Anschluss	Aansluiting	Racor
26	20191428		•	•	•	Raccordo	Raccord	Connector	Anschluss	Aansluiting	Racor

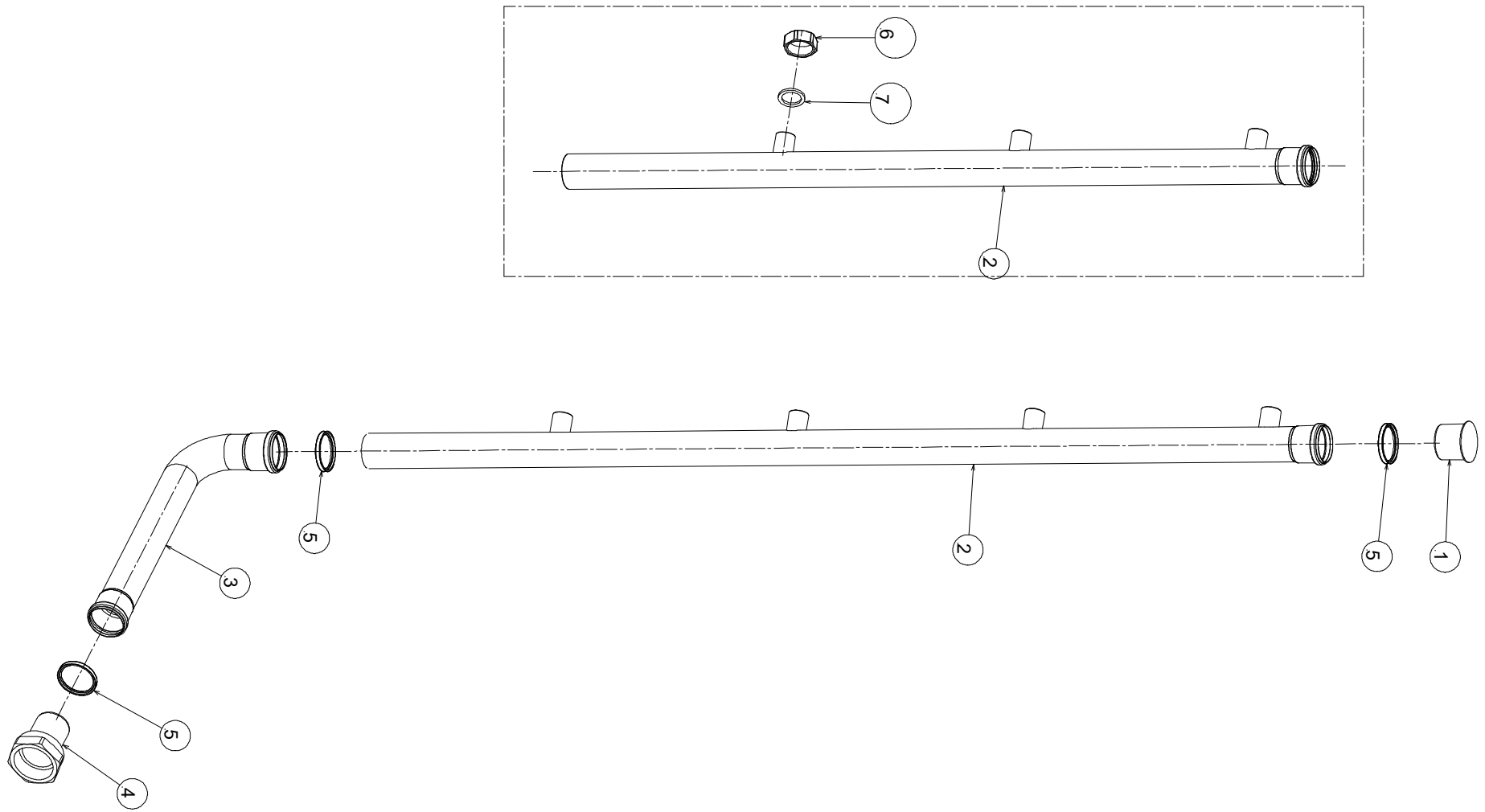

N.	COD.	RC	20177312	20177313	20177314	DESCRIZIONE	DESCRIPTION	DESCRIPTION	BESCHREIBUNG	BESCHRIJVING	DESCRIPCIÓN
1	20141041		•	•	•	Tappo	Bouchon	Plug	Verschluss	Dop	Tapón
2	20160043		•	•		Tubo di scarico	Tuyau évacuation	Drainage pipe	Auspuffrohr	Uitlaatpijp	Tubo de vaciado
2	20160010				•	Tubo di scarico	Tuyau évacuation	Drainage pipe	Auspuffrohr	Uitlaatpijp	Tubo de vaciado
3	20160015		•	•	•	Tubo di scarico	Tuyau évacuation	Drainage pipe	Auspuffrohr	Uitlaatpijp	Tubo de vaciado
4	20140813		•	•	•	Adattatore	Adaptateur	Adapter	Adapter	Adapter	Adapatador
5	20159974		•	•	•	Guarnizione	Joint	Seal	Dichtung	Afdichting	Junta
6	R.TAPPO069		•			Tappo	Bouchon	Plug	Verschluss	Dop	Tapón
7	20098040		•			Guarnizione	Joint	Seal	Dichtung	Afdichting	Junta

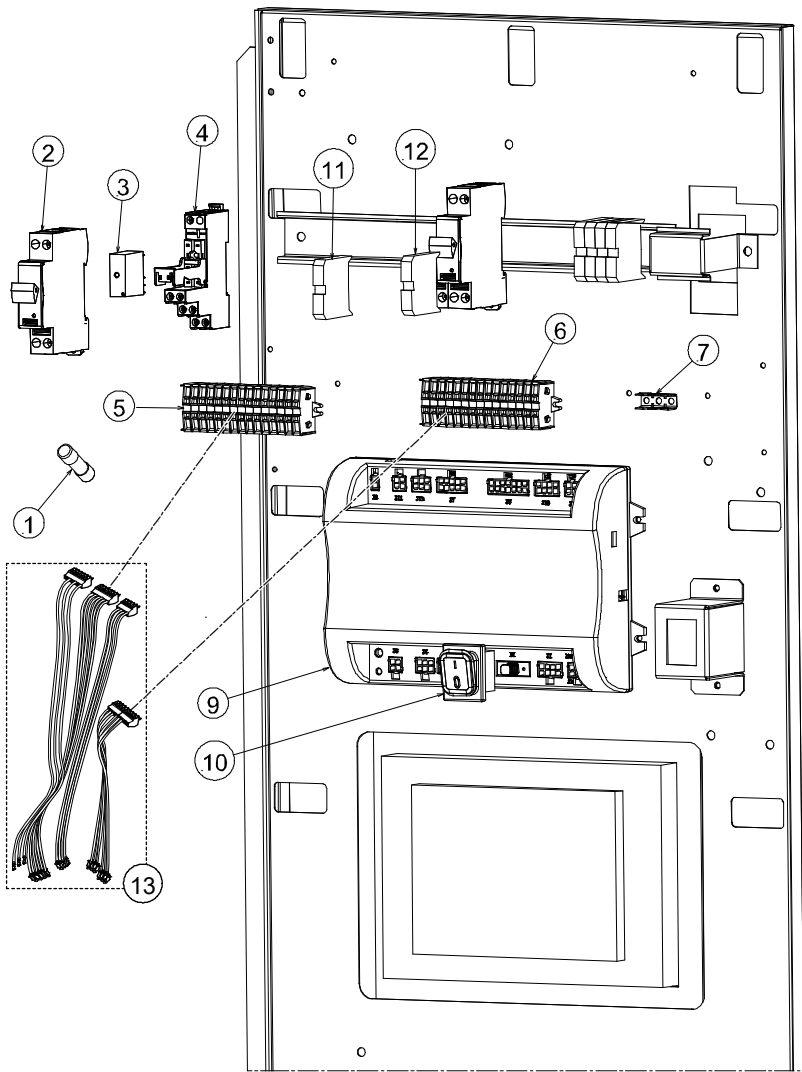

AR 1000 / AR 1500

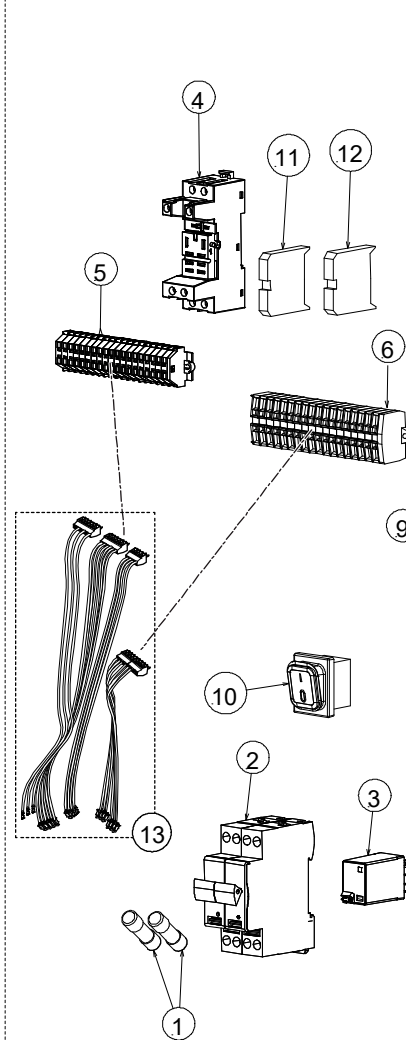

AR 2000

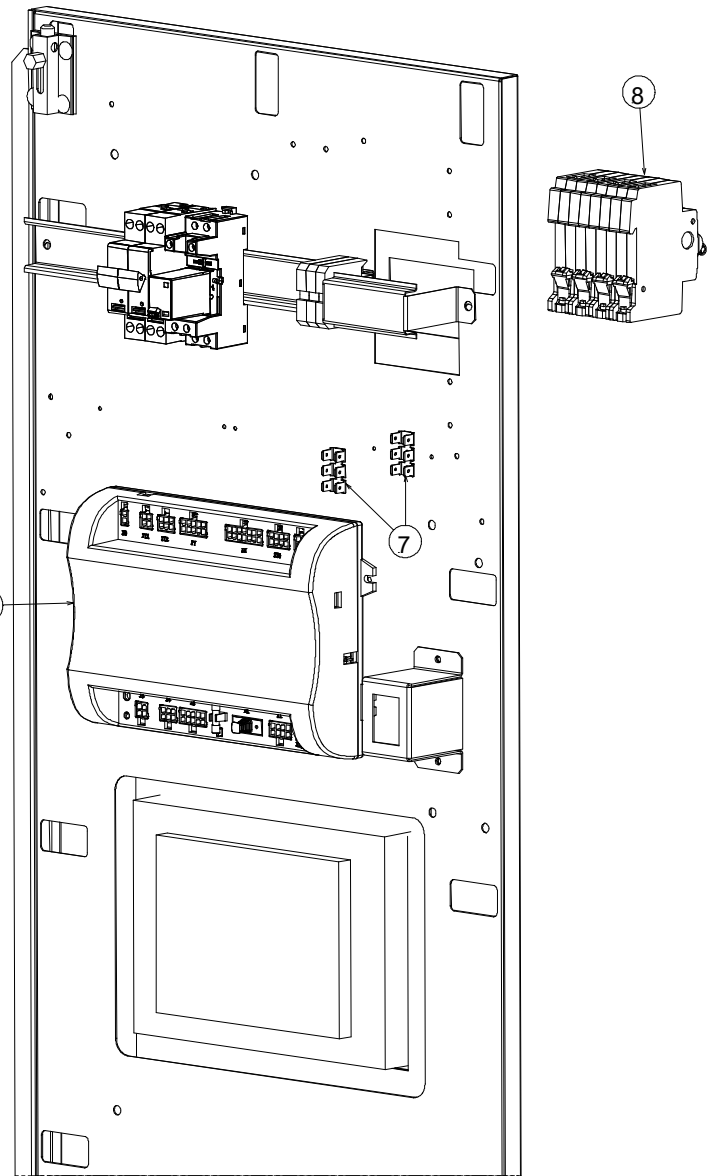

N.	COD.	RC	20177312	20177313	20177314	DESCRIZIONE	DESCRIPTION	DESCRIPTION	BESCHREIBUNG	BESCHRIJVING	DESCRIPCIÓN
1	20160056		•			Fusibile	Fusible	Fuse	Feinsicherung	Zekering	Fusible
1	20160053			•	•	Fusibile	Fusible	Fuse	Feinsicherung	Zekering	Fusible
2	20160035		•	•		Sezionatore	Disconnecteur	Disconnecter	Trennschalter	Ontkoppelaar	Seccionador
2	20120192				•	Sezionatore	Disconnecteur	Disconnecter	Trennschalter	Ontkoppelaar	Seccionador
3	20154915		•	•		Relè	Relais	Relay	Relais	Afstandsschakelaar	Relé
3	20154912				•	Relè	Relais	Relay	Relais	Afstandsschakelaar	Relé
4	20154916		•	•		Zoccolo	Socle	Control box base	Socket	Plint	Zócalo
4	20154913				•	Zoccolo	Socle	Control box base	Socket	Plint	Zócalo
5	20127233		•	•	•	Morsettiera	Bornier	Terminal board	Klemmleiste	Klemmenbord	Regleta
6	20098039		•	•	•	Morsettiera	Bornier	Terminal board	Klemmleiste	Klemmenbord	Regleta
7	20120291		•	•	•	Terminale	Cosse	Terminal	Terminal	Faston	Terminal
8	20120193		•	•	•	Interruttore automatico	Interrupteur automatique	Automatic switch	Automatischer Schalter	Automatische schakelaar	Interruptor automático
9	20209892		•	•	•	Scheda controllo	Carte de contrôle	Control PCB	Steuerkarte	Controlekaart	Tarjeta de control
10	20098045		•	•	•	Interruttore on-off	Interrupteur on-off	On-off switch	On-Off-Schalter	On-off schakelaar	Interruptor on-off
11	R.MORSET15		•	•	•	Morsetto	Clip	CLAMP	Klemme	Clip	Borne
12	R.016555		•	•	•	Morsetto	Clip	CLAMP	Klemme	Clip	Borne
13	20215512		•			Cablaggio alimentazione	Câblage alimentation	Feed wiring	Speiseverkabelung	Bekabeling voeding	cableado alimentación
13	20215513			•		Cablaggio alimentazione	Câblage alimentation	Feed wiring	Speiseverkabelung	Bekabeling voeding	cableado alimentación
13	20215514				•	Cablaggio alimentazione	Câblage alimentation	Feed wiring	Speiseverkabelung	Bekabeling voeding	cableado alimentación

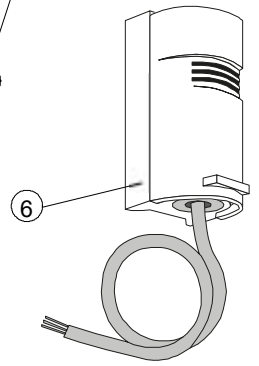
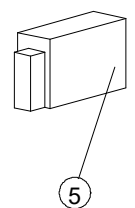
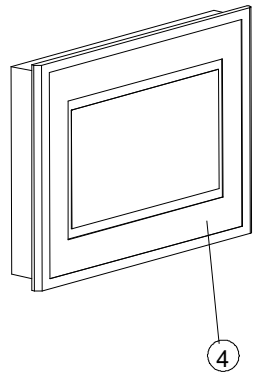
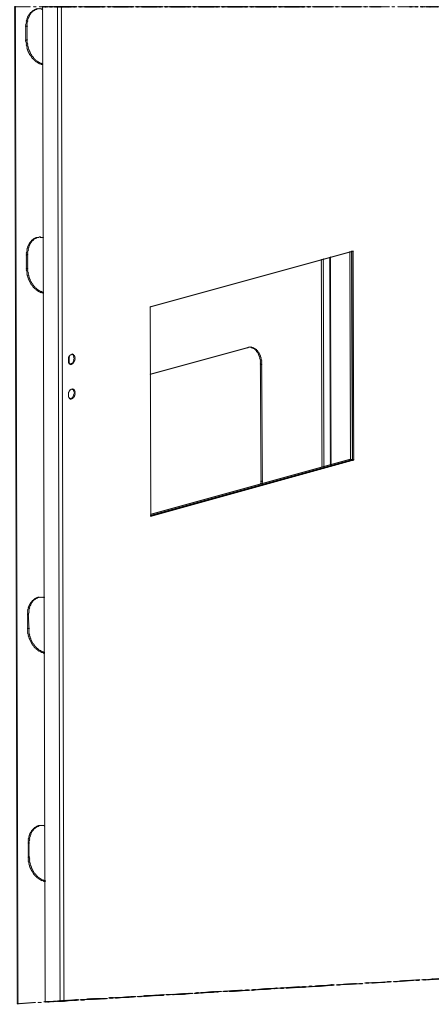
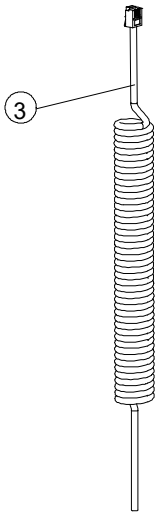
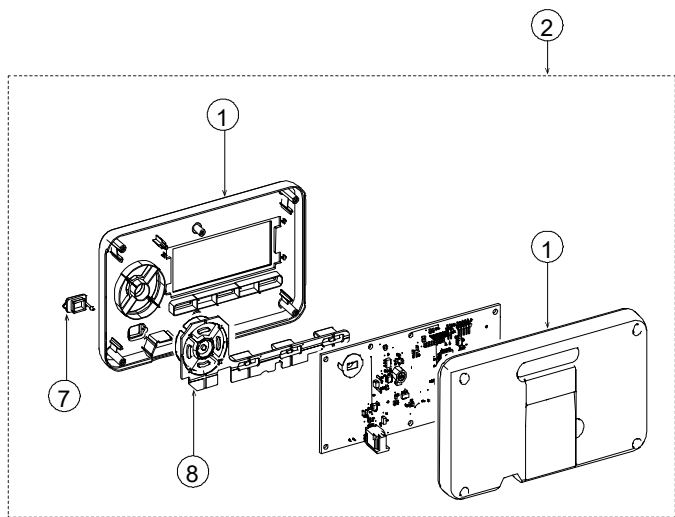

N.	COD.	RC			DESCRIZIONE	DESCRIPTION	DESCRIPTION	BESCHREIBUNG	BESCHRIJVING	DESCRIPCIÓN
		20177312	20177313	20177314						
1	20120290	•	•	•	Guscio	Couvercle	Half-shell	Haube	Deksel	Campana
2	20209937	•	•	•	Display	Carte display	Display	Bediehnfeld	Display	Display
3	20098025	•	•	•	Cavo collegamento tastiera	Câble cadran	Keyboard cable	Tastatur-Anschlusskabel	Toetsenbord kabel	Cable conexionado teclado
4	20180666	•	•	•	Display	Carte display	Display	Bediehnfeld	Display	Display
5	20126747	•	•	•	Alimentatore	Platine de commande	Power supply unit	Speiser	Voeder	Alimentador
6	20098078	•	•	•	Sonda temperatura esterna	Sonde température extérieure	Outside temperature probe	Außentemperaturfühler	Buiten temperatuur sensor	Sonda de temperatura externa
7	20098082	•	•	•	Tappo	Bouchon	Plug	Verschluss	Dop	Tapón
8	20098083	•	•	•	Tastiera	Clavier	Keyboard	Tastatur	Toetsenbord	Teclado

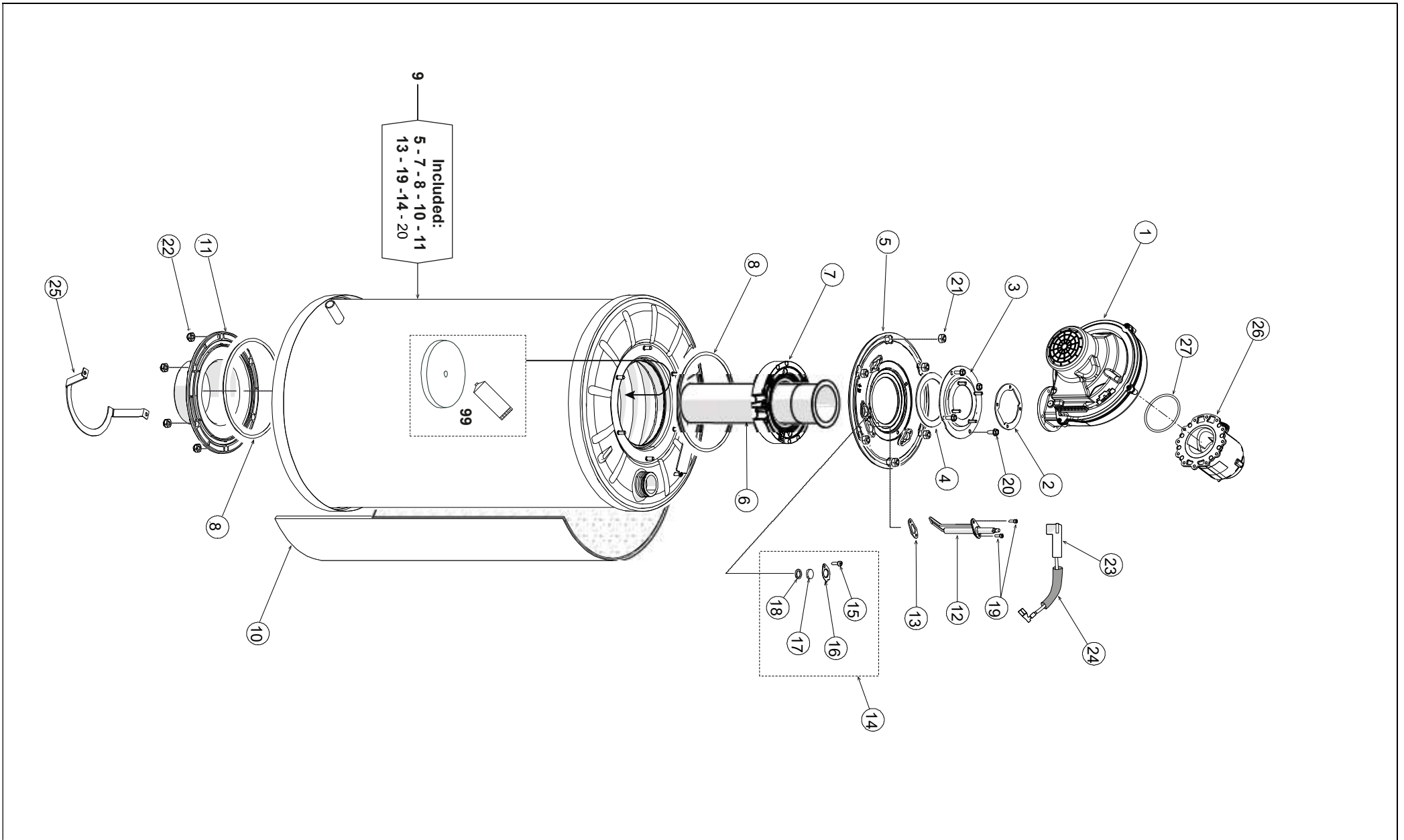

N.	COD.	RC	20177312	20177313	20177314	DESCRIZIONE	DESCRIPTION	DESCRIPTION	BESCHREIBUNG	BESCHRIJVING	DESCRIPCIÓN
1	20153745		•	•	•	Ventilatore	Ventilateur	Fan	Gebläse	Ventilator	Ventilador
2	20101521		•	•	•	Guarnizione	Joint	Seal	Dichtung	Afdichting	Junta
3	0CR105915		•	•	•	Flangia	Bride	Flange	Flansch	Contraflens	Brida
4	0CR105917		•	•	•	Guarnizione bruciatore	Joint brûleur	Burner seal	Brennerdichtung	Brander pakking	Junta quemador
5	20145777		•	•	•	Flangia	Bride	Flange	Flansch	Contraflens	Brida
6	20180403		•	•	•	Bruciatore	Brûleur	Burner	Brenner	Brander	Quemador
7	20202828		•	•	•	Isolamento camera fumi	Isolation chambre fumées	Flue gas chamber insulation	Isolierung für Abgaskastenab	Isolatie rookkamer	Aislamiento cámara de humos
8	20145794		•	•	•	Anello OR	Joint d'étanchéité	O-ring	OR-Dichtung	Pakkingring	Anillo de cierre
9	20207167		•	•	•	Scambiatore	Échangeur	Exchanger	Wärmetauscher	Warmtewisselaar	Intercambiador
10	20181005		•	•	•	Coibentazione	Isolation	Insulation	Isolierung	Isolatie	Aislamiento
11	20160154		•	•	•	Flangia fumi	Bride fumée	Flue gas flange	Rauchgasflansch	Rookflens	Brida humos
12	20107400		•	•	•	Elettrodo accensione e rilevazione	Electrode d'allumage	Ignition/detection electrode	Zünderlektrode	Ontsteking- en onderzoekelektrode	Electrodo de encendido
13	20102379		•	•	•	Guarnizione	Joint	Seal	Dichtung	Afdichting	Junta
14	20160133		•	•	•	Kit spia ispezione	Kit viseur	Spyhole inspection kit	Kontrollglas	Kit inspectieglaasje	Kit cristal
15	20145810		•	•	•	Vite	Vis sans fin	Screw	Schraube	Toevoerschroef	Perno
16	20145792		•	•	•	Fermavetro	Bague de fixation	Glass holder	Glasleiste	Glashouder	Sujeta cristal
17	20145791		•	•	•	Vetrino	Regard	Viewing port	Verschlussstopfen	Glaasje	Cubreobjeto
18	20145783		•	•	•	Guarnizione spioncino	Joint viseur	Inspection hole seal	Guckloch Dichtung	Pakking kijkgat	Junta mirilla
19	20145820		•	•	•	Vite	Vis sans fin	Screw	Schraube	Toevoerschroef	Perno
20	20145806		•	•	•	Vite	Vis sans fin	Screw	Schraube	Toevoerschroef	Perno
21	20145774		•	•	•	Dado	Écrou	Nut	Mutter	Moer	Tuerca
22	20145798		•	•	•	Dado	Écrou	Nut	Mutter	Moer	Tuerca
23	20126741		•	•	•	Cavo accensione	Cable pour électrode d'allumage	Ignition cable	Zündkabel	Startkabel	Cable de encendido
24	20120077		•	•	•	Guaina	Gaine	Sheath	Hülse	Voering	Vaina
25	20180677		•	•	•	Staffa	Support	Bracket	Halteblech	Selhouder	Abrazadera

N.	COD.	RC	DESCRIZIONE			DESCRIPTION	DESCRIPTION	BESCHREIBUNG	BESCHRIJVING	DESCRIPCIÓN	
			20177312	20177313	20177314						
26	20191542		•	•	•	Mixer	Mixer	Mixer	Mixer	Mixer	
27	20153425		•	•	•	Anello OR	Joint d'etancheite	O-ring	OR-Dichtung	Pakkingring	Anillo de cierre
99	20091244		•	•	•	Kit disco refrattario	Kit disque rÃ©fractaire	Refractory disc kit	Feuerfestscheibe set	Vuurvastplaat kit	Kit disco refractario

AR 2000

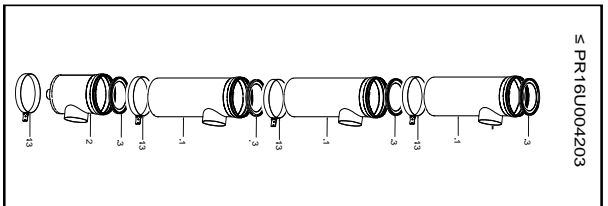

AR 1500

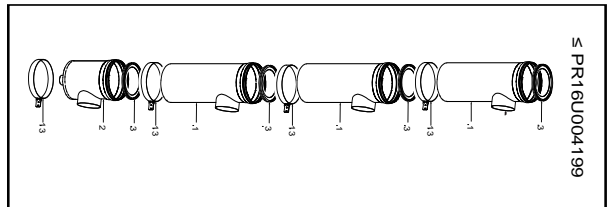

AR 1000

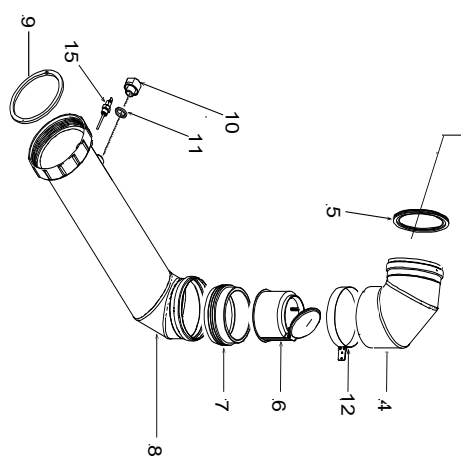
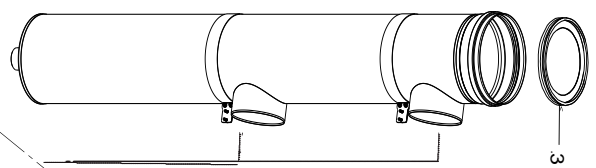
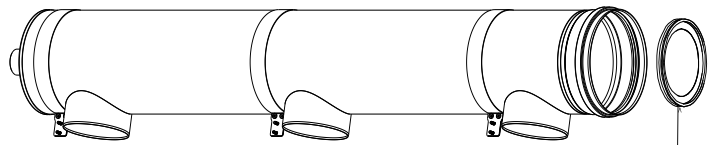
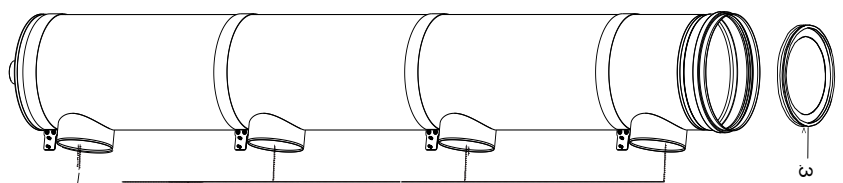
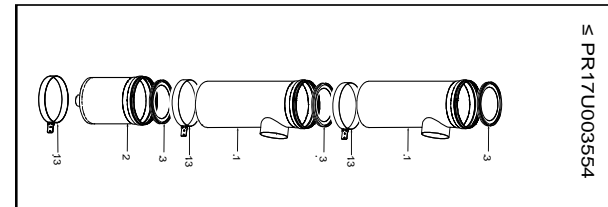

N.	COD.	RC	20177312	20177313	20177314	DESCRIZIONE	DESCRIPTION	DESCRIPTION	BESCHREIBUNG	BESCHRIJVING	
1	20180662	D	•	•		Collettore fumi	Collecteur fumées	Flue gas manifold	Abgasanschlusselement	Rookgasaansluitstuk	≤ PR16U004203
1	20227172		•			Tubo	Tuyau	Pipe	Rohr	Buis	≥ PR17U003555
1	20227170			•		Collettore fumi	Collecteur fumées	Flue gas manifold	Abgasanschlusselement	Rookgasaansluitstuk	≥ PR16U004204
1	20181146	D			•	Collettore fumi	Collecteur fumées	Flue gas manifold	Abgasanschlusselement	Rookgasaansluitstuk	≤ PR16U004203
1	20227163				•	Collettore fumi	Collecteur fumées	Flue gas manifold	Abgasanschlusselement	Rookgasaansluitstuk	≥ PR16U004204
2	20181145	D	•			Tappo scarico	Bouchon évacuation	Drainage plug	Ablaufstopfen	Aftapplug	≤ PR17U003554
2	20180663	D		•		Collettore fumi	Collecteur fumées	Flue gas manifold	Abgasanschlusselement	Rookgasaansluitstuk	≤ PR16U004203
2	20181147	D			•	Collettore fumi	Collecteur fumées	Flue gas manifold	Abgasanschlusselement	Rookgasaansluitstuk	≤ PR16U004203
3	20180836	A	•	•		Guarnizione scarico fumi	Joint évacuation fumée	Flue gas exhaust seal	Rauchabgase Dichtung	Pakking rookafvoer	
3	20180837	A			•	Guarnizione scarico fumi	Joint évacuation fumée	Flue gas exhaust seal	Rauchabgase Dichtung	Pakking rookafvoer	
4	20180655	D	•	•	•	Gomito	Coude	Elbow	Gasschlitten	Elleboog	≤ PR16U004203
4	20227158		•	•	•	Gomito	Coude	Elbow	Gasschlitten	Elleboog	≥ PR16U004204
5	20180835	A	•	•	•	Guarnizione scarico fumi	Joint évacuation fumée	Flue gas exhaust seal	Rauchabgase Dichtung	Pakking rookafvoer	
6	20207546	D	•	•	•	Valvola clapet	Clapet	Flap valve	Clapetventil	Stuw	≤ PR17U003554
6	20212242	D	•	•	•	Valvola clapet	Clapet	Flap valve	Clapetventil	Stuw	≥ PR17U003555
7	20120076	D	•	•	•	Guarnizione	Joint	Seal	Dichtung	Afdichting	
8	20180644	C	•	•		Tubo scarico fumi	Tuyau évacuation fumées	Flue gas exhaust pipe	Abgasleitung	Afvoerbuis rookgassen	≤ PR16U004203
8	20227161		•	•		Gomito	Coude	Elbow	Gasschlitten	Elleboog	≥ PR16U004204
8	20181157	C			•	Tubo scarico fumi	Tuyau évacuation fumées	Flue gas exhaust pipe	Abgasleitung	Afvoerbuis rookgassen	≤ PR16U004203
8	20227164				•	Gomito	Coude	Elbow	Gasschlitten	Elleboog	≥ PR16U004204
9	20180614	A	•	•	•	Guarnizione	Joint	Seal	Dichtung	Afdichting	
10	20116714	D	•	•	•	Tappo con guarnizione	Bouchon avec joint	Plug with seal	Verschluss mit Dichtung	Plug met afdichting	
11	R. ORING128	A	•	•	•	Anello OR	Joint d'étancheite	O-ring	OR-Dichtung	Pakkingring	
12	20180681	D	•	•	•	Fascia	Collier	Ring	Band	Flens	
13	20180682	D	•	•		Fascia	Collier	Ring	Band	Flens	
13	20182332	D			•	Fascia	Collier	Ring	Band	Flens	
15	20060687	A	•	•	•	Sonda temperatura	Sonde température	Temperature probe	Temperaturfühler	Temperatuur sensor	

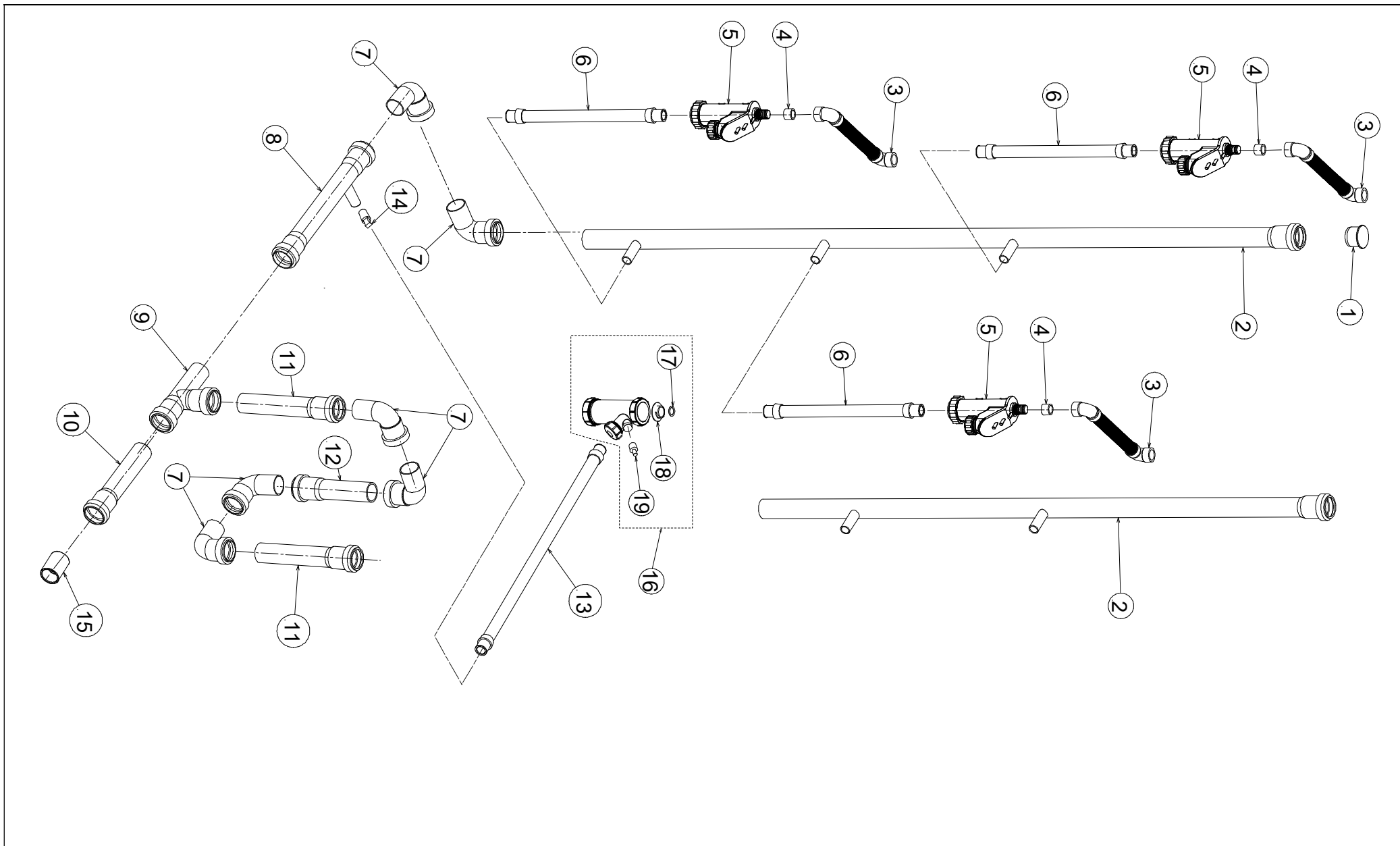

N.	COD.	RC	20177312	20177313	20177314	DESCRIZIONE	DESCRIPTION	DESCRIPTION	BESCHREIBUNG	BESCHRIJVING	DESCRIPCIÓN
1	20120230		•	•	•	Tappo	Bouchon	Plug	Verschluss	Dop	Tapón
2	20120231		•	•		Tubo scarico condensa	Tuyau évacuation buée	Condensation drainage pipe	Abflussrohr Kondenswasser	Condensafvoerslang	Tubo evacuación de condensados
2	20120198				•	Tubo scarico condensa	Tuyau évacuation buée	Condensation drainage pipe	Abflussrohr Kondenswasser	Condensafvoerslang	Tubo evacuación de condensados
3	20212239		•	•	•	Tubo flessibile	Tuyau flexible	Hose	Schlauch	Flexibele buis	Tubo flexible
4	20139129		•	•	•	Riduzione	Pièce de réduction	Transition piece	Übergangsstück	Reductie	Reducción
5	20120079		•	•	•	Sifone scarico condensa	Siphon évacuation buée	Condensation drainage syphon	Kondenswassersyphon	Condensafvoer	Sifón condensación
6	20212238		•	•	•	Tubo flessibile	Tuyau flexible	Hose	Schlauch	Flexibele buis	Tubo flexible
7	20120228		•	•	•	Gomito	Coude	Elbow	Gasschlitten	Elleboog	Codo
8	20120232		•	•	•	Tubo scarico condensa	Tuyau évacuation buée	Condensation drainage pipe	Abflussrohr Kondenswasser	Condensafvoerslang	Tubo evacuación de condensados
9	20120227		•	•	•	Raccordo scarico	Raccord évacuation	Drainage connector	Abflusanschluss	Afvoeraansluiting	Conector de descarga (vaciado)
10	20120226		•	•	•	Tubo scarico condensa	Tuyau évacuation buée	Condensation drainage pipe	Abflussrohr Kondenswasser	Condensafvoerslang	Tubo evacuación de condensados
11	20126735		•	•		Tubo scarico condensa	Tuyau évacuation buée	Condensation drainage pipe	Abflussrohr Kondenswasser	Condensafvoerslang	Tubo evacuación de condensados
11	20127232				•	Tubo scarico condensa	Tuyau évacuation buée	Condensation drainage pipe	Abflussrohr Kondenswasser	Condensafvoerslang	Tubo evacuación de condensados
12	20120240		•	•		Tubo scarico condensa	Tuyau évacuation buée	Condensation drainage pipe	Abflussrohr Kondenswasser	Condensafvoerslang	Tubo evacuación de condensados
12	20120264				•	Tubo scarico condensa	Tuyau évacuation buée	Condensation drainage pipe	Abflussrohr Kondenswasser	Condensafvoerslang	Tubo evacuación de condensados
13	20212237			•	•	Tubo scarico condensa	Tuyau évacuation buée	Condensation drainage pipe	Abflussrohr Kondenswasser	Condensafvoerslang	Tubo evacuación de condensados
14	20126737		•			Tappo	Bouchon	Plug	Verschluss	Dop	Tapón
15	20159980		•	•	•	Adattatore	Adaptateur	Adapter	Adapter	Adapter	Adapatador
16	20181030			•	•	Sifone scarico condensa	Siphon évacuation buée	Condensation drainage syphon	Kondenswassersyphon	Condensafvoer	Sifón condensación

N.	COD.	RC	RC		DESCRIZIONE	DESCRIPTION	DESCRIPTION	BESCHREIBUNG	BESCHRIJVING	DESCRIPCIÓN
			20177312	20177313						
17	20181042		•	•	Anello OR	Joint d'étancheite	O-ring	OR-Dichtung	Pakkingring	Anillo de cierre
18	20181044		•	•	Attacco	Raccord	Fitting	Anschluss	Aansluiting	Racor
19	20181048		•	•	Tappo scarico	Bouchon évacuation	Drainage plug	Ablaufstopfen	Aftapplug	Tapón vaciado

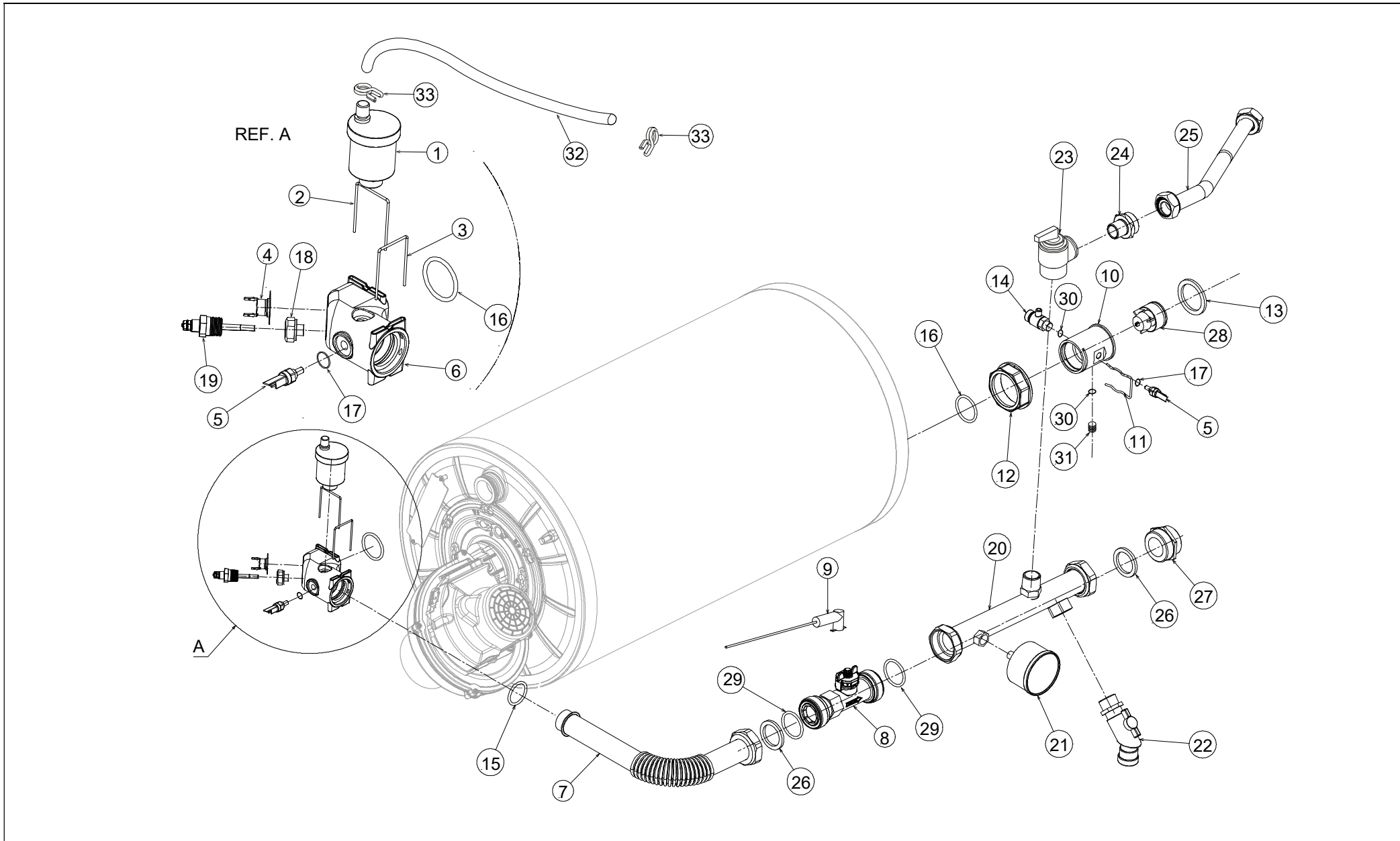

N.	COD.	RC	20177312	20177313	20177314	DESCRIZIONE	DESCRIPTION	DESCRIPTION	BESCHREIBUNG	BESCHRIJVING
1	20228546		•	•	•	Valvola sfiato aria	Soupape de dégagement d'air	Air venting valve	Luftablassventil	Ontluchtingsklep
1	20226778		•	•	•	Tappo filettato	Bouchon à vis	Cap nut	Gewindestopfen	Schroefdraadplug
2	20101597	D	•	•	•	Molletta	Clip	Clip	Feder	Clip
3	20101599	D	•	•	•	Molletta	Clip	Clip	Feder	Clip
4	20139169	B	•	•	•	Termostato sicurezza	Thermostat sécurité	Safety thermostat	Sicherheitsthermostat	Veiligheidsthermostaat
5	20098080	A	•	•	•	Sonda ad immersione	Sonde en plongée	Immersion probe	Tauchfühler	Dompelvoeler sensor
6	20159982	C	•	•	•	Raccordo rapido di mandata	Raccord rapide depart	Delivery quick connection	Vorlauf Schellkupplung Anschluss	Toeroer Snelaansluiting
7	20120178	C	•	•	•	Tubo acqua uscita	Tuyau sortie eau	Water drainage pipe	Ausgangsrohr wasser	Afvoerbuis
8	20120074	B	•	•	•	Flussometro	Débitmètre	Flow meter	Strömungszähler	Flowmeter
9	20120161	B	•	•	•	Cavo alimentazione	Cable d'alimentation	Power supply cable	Stromversorgungskabel	Voedingskabel
10	20159963	C	•	•	•	Canotto	Cartouche modulation	Core holder	Schaft	Drijver
11	20093998	D	•	•	•	Molletta	Clip	Clip	Feder	Clip
12	20120048	C	•	•	•	Raccordo	Raccord	Connector	Anschluss	Aansluiting
13	20120249	A	•	•	•	Guarnizione	Joint	Seal	Dichtung	Afdichting
14	20011234	A	•	•	•	Valvola di scarico	Vanne de décharge	Drainage valve	Auslassventil	Uitlaaklepe
15	20217340		•	•	•	Anello OR	Joint d'étancheite	O-ring	OR-Dichtung	Pakkingring
16	20101600	A	•	•	•	Anello OR	Joint d'étancheite	O-ring	OR-Dichtung	Pakkingring
17	20098044	A	•	•	•	Guarnizione	Joint	Seal	Dichtung	Afdichting
18	20098064	C	•	•	•	Raccordo	Raccord	Connector	Anschluss	Aansluiting
19	20116627	A	•	•	•	Sensore	Detecteur	Sensor	Fühler	Sensor
20	20159956	C	•	•	•	Tubo mandata	Tuyau départ	Delivery pipe	Vorlaufrohr	Toevoerbuis
21	20164524	B	•	•	•	Termoidrometro	Thermohydromètre	Thermometer-hydrometer	Thermometer/Füllmesser	Thermo-hydrometer
22	20107403	C	•	•	•	Rubinetto	Robinet	Cock	Hahn	Kraan
23	20160054	A	•	•	•	Valvola di sicurezza	Soupape de sûrete	Safety valve	Sicherheitsventil	Veiligheidsklep
24	20098139	C	•	•	•	Nipple	Mamelon	Nipple	Nippel	Nippels

N.	COD.	RC	20177312	20177313	20177314	DESCRIZIONE	DESCRIPTION	DESCRIPTION	BESCHREIBUNG	BESCHRIJVING	
25	20160002	C	•	•	•	Tubo di scarico	Tuyau évacuation	Drainage pipe	Auspuffrohr	Uitlaatpijp	
26	20120250	A	•	•	•	Guarnizione	Joint	Seal	Dichtung	Afdichting	
27	20159960	C	•	•	•	Raccordo	Raccord	Connector	Anschluss	Aansluiting	
28	R.VALVO04 4	D	•	•	•	Valvola di non ritorno	Vanne anti-retour	Non-return valve	Rückschlagventil	Terugslagklep	
29	20098128	A	•	•	•	Anello OR	Joint d'étancheite	O-ring	OR-Dichtung	Pakkingring	
30	20120243	A	•	•	•	Guarnizione	Joint	Seal	Dichtung	Afdichting	≤ PR43T002967
31	20125395	C	•	•	•	Tappo filettato	Bouchon à vis	Cap nut	Gewindestopfen	Schroefdraadplug	
32	20120275	C	•	•	•	Tubo presa pressione	Tuyau prise pression	Pressure socket pipe	Rohr Druckaufnahme	Buis uitlaatdruk	
33	20174357	D	•	•	•	Fascetta	Collier	Hose strap	Schelle	Flens	

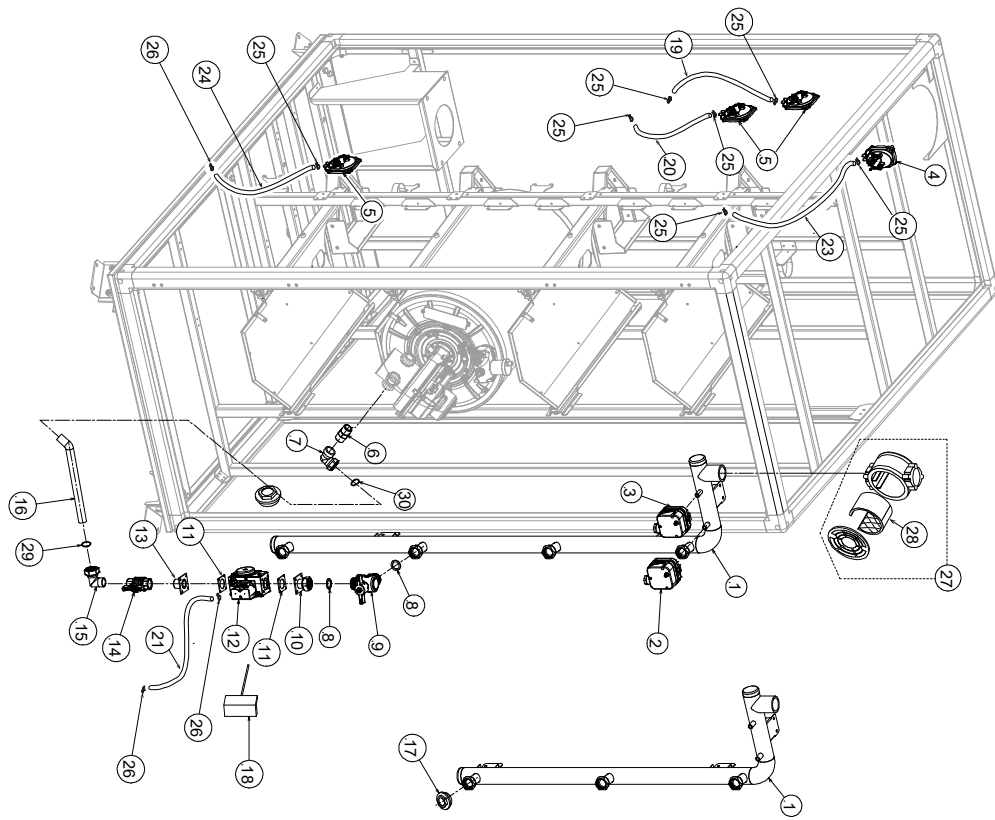

20177312 ≤ PR12S006144
 20177313 ≤ PR07S001181
 20177314 ≤ PR07S001205

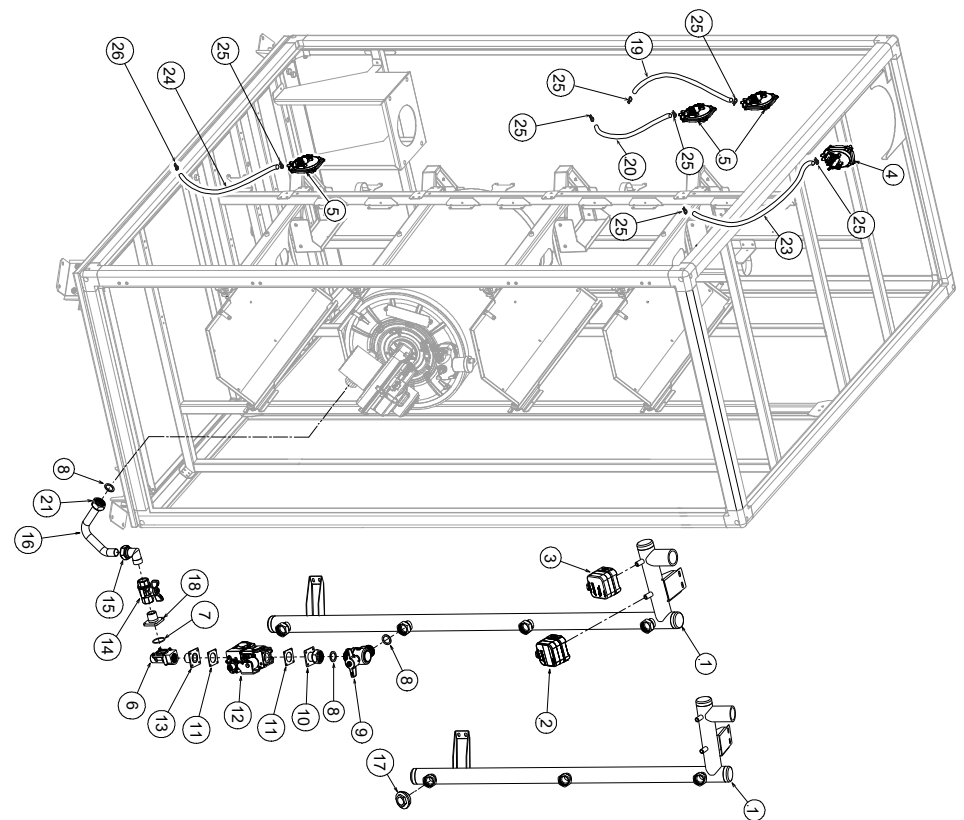

20177312 ≥ PR12S006145
 20177313 ≥ PR07S001182
 20177314 ≥ PR07S001206

N.	COD.	RC	20177312	20177313	20177314	DESCRIZIONE	DESCRIPTION	DESCRIPTION	BESCHREIBUNG	BESCHRIJVING	DESCRIPCIÓN
1	20215515		•	•		Collettore gas	Collecteur gaz	Gas manifold	Gassammler	Gascollector	Colector de gas
1	20215516				•	Collettore gas	Collecteur gaz	Gas manifold	Gassammler	Gascollector	Colector de gas
2	20102305		•	•	•	Pressostato gas	Pressostat gaz	Gas pressure switch	Gasdruckwächter	Gasdrukregelaar	Presostato de gas
3	20126738		•	•	•	Pressostato gas	Pressostat gaz	Gas pressure switch	Gasdruckwächter	Gasdrukregelaar	Presostato de gas
4	20098056		•	•	•	Pressostato differenziale	Pressostat différentiel	Differential pressure switch	Differenzdruckwächter	Differentiaal drukregelaar	Presostato diferencial
5	20120170		•	•	•	Pressostato differenziale	Pressostat différentiel	Differential pressure switch	Differenzdruckwächter	Differentiaal drukregelaar	Presostato diferencial
6	4R109038		•	•	•	Raccordo gas (throttle)	Raccord gaz (throttle)	Gas union (throttle)	Gasansschluss (throttle)	Gasaansluiting (throttle)	Racor de gas (throttle)
7	4R109077		•	•	•	Anello OR	Joint d'étancheite	O-ring	OR-Dichtung	Pakkingring	Anillo de cierre
8	20098040		•	•	•	Guarnizione	Joint	Seal	Dichtung	Afdichting	Junta
9	20060598		•	•	•	Rubinetto	Robinet	Cock	Hahn	Kraan	Grifo
10	20061493		•	•	•	Raccordo gas	Raccord gaz	Gas union	Gasansschluss	Gasaansluiting	Racor de gas
11	20098043		•	•	•	Guarnizione valvola gas	Joint vanne gaz	Gas valve seal	Gasventildichtung	Afdichting gasklep	Junta valvola de gas
12	20180603		•	•	•	Valvola gas	Vanne gaz	Gas valve	Gasventil	Gasklep	Válvula de gas
13	20126739		•	•	•	Raccordo flangiato	Raccord retour	Flanged connector	Anschluss	Aansluiting	Racor
14	20098147		•	•	•	Valvola	Vanne	Valve	Ventil	Klep	Válvula
15	20061501		•	•	•	Curva	Courbe	Bend	Bogen	Kromme	Curva
16	20215517		•	•	•	Tubo gas	Tuyau gaz	Gas pipe	Gasrohr	Gas buis	Tubo de gas
17	20120322		•			Tappo cieco	Bouchon de fermeture	Blind plug	Blindstopfen	Blinde dop	Tapón ciego
18	20215518		•	•	•	Raccordo flangiato	Raccord retour	Flanged connector	Anschluss	Aansluiting	Racor
19	20120266		•	•	•	Tubo presa pressione	Tuyau prise pression	Pressure socket pipe	Rohr Druckaufnahme	Buis uitlaatdruk	Tubo toma de presión
20	20120269		•	•	•	Tubo presa pressione	Tuyau prise pression	Pressure socket pipe	Rohr Druckaufnahme	Buis uitlaatdruk	Tubo toma de presión
21	20212647		•	•	•	Raccordo	Raccord	Connector	Anschluss	Aansluiting	Racor
23	20120271		•	•	•	Tubetto silicone	Tube en silicone	Silicon tube	Silikonröhrchen	Silicone slang	Tubo de silicona
24	20181124		•	•	•	Tubo presa pressione	Tuyau prise pression	Pressure socket pipe	Rohr Druckaufnahme	Buis uitlaatdruk	Tubo toma de presión
25	20150969		•	•	•	Fascetta	Collier	Hose strap	Schelle	Flens	Abrazadera

N.	COD.	RC	DESCRIZIONE	DESCRIPTION	DESCRIPTION	BESCHREIBUNG	BESCHRIJVING	DESCRIPCIÓN
26	20174357	<ul style="list-style-type: none"> • 20177312 • 20177313 • 20177314 	Fascetta	Collier	Hose strap	Schelle	Flens	Abrazadera

A = Ricambi per dotazione minima - Pièces détachées pour équipement minimum - Spare parts for minimum fittings - Ersatzteile für minimale Ausstattung - Reserveonderdelen voor minimale uitrusting - Recambios para equipamiento mínimo

A+B = Ricambi per dotazione base di sicurezza - Pièces détachées pour équipement standard de sécurité - Spare parts for basic safety fittings - Ersatzteile für sicherheitsgrundausrüstung - Reserveonderdelen voor basis veiligheidsuitrusting - Recambios para equipamiento básico de seguridad

A+B+C = Ricambi per dotazione estesa di sicurezza - Pièces détachées pour équipement complet de sécurité - Spare parts for extended safety fittings - Ersatzteile für erweiterte Sicherheitsgrundausrüstung - Reserveonderdelen voor uitgebreide veiligheidsuitrusting - Recambios para equipamiento general de seguridad

RIELLO

Riello S.p.A.
37045 Z.A.I. di San Pietro di Legnago (Verona) Via Ing. Pilade Riello, 7
Tel. 0442/630.111 - Fax 0442/22378 <http://www.riello.it>
archivio <http://ics.riello.it>

La nostra azienda, nella costante azione migliorativa sul prodotto, si riserva la possibilità di modificare i dati riportati in questo documento in qualsiasi momento e senza preavviso. - Puisque l'entreprise cherche constamment à perfectionner toute sa production, les caractéristiques esthétiques et dimensionnelles, les données techniques, les équipements et les accessoires, peuvent subir des modifications. - The manufacturer strives to continuously improve all products. Appearance, dimensions, technical specifications, standard equipment and accessories are therefore liable to modification without notice. - Da das Unternehmen konstant um die Perfektionierung seiner Produktion bemüht ist, können das äußere Erscheinungsbild, die Abmessungen, die technischen Daten, die Ausstattungen sowie Zubehörteile Änderungen unterworfen werden. - In een voortdurend streven naar het verbeteren van onze producten, behouden wij ons het recht voor om de gegevens in dit document op elk moment te wijzigen, zonder kennisgeving vooraf. - Nuestra empresa dedica sus esfuerzos al constante perfeccionamiento de toda su producción, por eso las características estéticas y las dimensiones, los datos técnicos, los equipamientos y los accesorios pueden estar sometidos a variación.

8489