

⚠ WARNING: If the information in this manual is not followed exactly, a fire or explosion may result causing property damage, personal injury or loss of life.

Do not store or use gasoline or other flammable vapors and liquids or other combustible materials in the vicinity of this or any other appliance. To do so may result in an explosion or fire.

What to do if you smell gas:

- Do not try to light any appliance;
- Do not touch any electrical switch; do not use any phone in your building;
- Immediately call your gas supplier from a neighbor's phone. Follow the gas supplier's instructions;
- If you cannot reach your gas supplier, call the fire department.

Installation and service must be performed by a qualified installer, service agency or the gas supplier.

This manual should be maintained in legible condition and kept adjacent to the boiler or in a safe place for future reference.



Array AR 399 SE – 500 SE

US INSTALLATION AND OPERATION MANUAL

RIELLO

Attention Heating Engineer,
 Congratulations for purchasing a **RIELLO** boiler. This appliance ensures maximum comfort over a long life, with high reliability, efficiency, performance, quality and safety.
 This manual provides information that is essential to the installation of the appliance. Used in conjunction with your own knowledge and expertise, it will enable you to install the appliance quickly, easily, and correctly.

Please accept our thanks and our congratulations on your choice of product.
RIELLO S.p.A.

CONFORMITY



The information contained in this manual is subject to change without notice from **RIELLO** SpA. **RIELLO** makes no warranty of any kind with respect to this material, including but not limited to implied warranties of merchantability and fitness for a particular application. **RIELLO** is not liable for errors appearing in this manual, nor for incidental or consequential damages occurring in connection with the furnishing, performance, or use of this material.

RANGE

MODEL	ASSEMBLY NUMBER
Array AR 399 SE	20181721
Array AR 500 SE	20181722

⚠ WARNING: If the information in these instructions is not followed exactly, a fire or explosion may result causing property damage, personal injury or death.

⚠ WARNING: Do not store or use gasoline or other flammable vapors and liquids in the vicinity of this or any other appliance.

WHAT TO DO IF YOU SMELL GAS:

- Do not try to light any appliance.
- Do not touch any electrical switch; do not use any phone in your building.
- Immediately call your gas supplier from a neighbor's phone. Follow the gas supplier's instructions.
- If you cannot reach your gas supplier, call the fire department.

Qualified installer, service agency or the gas supplier must perform installation and service.

⚠ FOR YOUR SAFETY: Improper installation and/or operation could create carbon monoxide gas in flue gases which could cause serious injury, property damage, or death.

Improper installation and/or operation will void the warranty.

1	GENERAL	4
1.1	Warnings & Cautions	4
1.2	Safety Instructions	5
1.3	General Warning	5
2	PRODUCT DESCRIPTION	6
2.1	Description of the appliance	6
2.2	Scope of Delivery	6
2.3	Proper Use	6
2.4	Environmental Responsibility / Disposal	6
2.5	Emergency Shutdown	6
2.6	Prolonged Shutdown	6
2.7	Additional regulations for installations in the Commonwealth of Massachusetts	7
2.8	Identification	8
2.9	Dimension	9
2.10	System layout	10
2.11	Water circuit	11
2.12	Technical specifications	12
2.13	Efficiency Curves	13
3	REGULATIONS AND GUIDELINES	15
3.1	Compliance with standards and regulations	15
3.2	Operating limits of the boiler	15
4	INSTALLATION	16
4.1	Introduction	16
4.2	Receiving the Unit	16
4.3	Unpacking	16
4.4	Site Preparation	16
4.4.1	Installation clearances	16
4.4.2	Setting the Unit	17
4.5	Installation in older systems and systems requiring modifications	18
4.6	Boiler Location	18
4.7	Water connection	18
4.7.1	Minimum Water Flow (Heat Exchanger Protection)	18
4.7.2	Heating System Pressure Test	19
4.8	Water Quality Guidelines	19
4.9	Safety devices	19
4.10	High Limit Safety Switch	20
4.11	Low Water Cutoff	20
4.12	Pressure Relief Valve installation	20
4.13	Condensate Drain and Piping	21
4.14	Gas connections	21
4.15	Adjusting and Setting O ₂ Limits	22
4.16	Combustion gas exhaust	22
4.17	Wiring diagram	24
4.18	AC Electrical Power Wiring	26
4.18.1	Electrical Power Requirements	26
4.19	Field Control Wiring	27
5	AIR DAMPER	28
6	COMMISSIONING	29
6.1	Boiler Startup Procedure	29
7	OPERATION	33
7.1	Introduction	33
7.2	Control Panel Description	33
7.3	Touchscreen Control Panel Menu	33
7.3.1	Riello Screen	33
7.3.2	Module Screen	33
7.3.3	Performance Screen	34
7.3.4	Service Screen	34
7.3.5	Test Screen	34

7.3.6	Cascade Screen	35
7.3.7	Module Screen	35
7.3.8	Performance Screen	35
7.3.9	Error Screen	36
7.3.10	Service Screen	36
7.3.11	Module Test Screen	36
7.3.12	Module Configuration	36
8	SYSTEM MANAGEMENT	37
8.1	Communication between the boilers/modules	37
8.2	Multiple Boiler Cascade Installation and Start-Up	37
8.3	Setting the type of module addressing	38
8.4	Module addressing via dip switches	38
8.5	Address configuration via Display	39
8.6	Bus connections	39
9	CONFIGURATION OF THE MAIN BLOCK DIAGRAMS	40
9.1	Configuration of the primary system	40
9.2	Configuration of the secondary system	40
9.3	Block diagram	42
9.3.1	Electrical power connections	42
9.3.2	Sensor connections	43
9.3.3	Bus connections	43
9.3.4	System parameters	44
9.4	Block diagram	45
9.4.1	Electrical power connections	46
9.4.2	Sensor connections	46
9.4.3	System parameters	47
9.5	Setting the main parameters	48
9.5.1	Par. 189 – module address (burner)	48
9.5.2	Par. 147 – no. of modules (burners)	48
9.5.3	Par. 73 – Boiler address (cabinet)	48
9.6	Par. 167 – no. of boilers (cabinets)	48
9.6.1	Par. 7 – heating setpoint hysteresis	48
9.7	Configurable boiler error	48
9.8	Par. 148: operating mode of the cascade	49
9.8.1	Par. 148 = 0	49
9.8.2	Par. 148 = 1	49
9.8.3	Par. 148 = 2	49
APPENDIX A – GAS TYPE CONVERSION		50
APPENDIX B – MAINTENANCE		51
APPENDIX C – HEAD AVAILABLE FOR THE SYSTEM		52
APPENDIX D – VENTING SIZE DATA		53
APPENDIX E – EXHAUST TERMINALS AND AIR INLET CLEARANCES		54
APPENDIX F – DE-RATING FOR ALTITUDE INSTALLATION		62
APPENDIX G – DISPLAY AND MAIN BOARD REPLACEMENT		63
APPENDIX H – ELECTRONIC CONTROL		64
APPENDIX I – LIST OF PARAMETERS (WITH RANGES AND DEFAULT VALUES)		68
APPENDIX J – TROUBLESHOOTING TABLE		77
APPENDIX K – CONNECTION DIAGRAM		82
APPENDIX L – TS ADDRESS		83
APPENDIX M – FLOWCHARTS		86

1 GENERAL

The **RIELLO Array AR 399 SE** and **AR 500 SE** are fully modulating, high-efficiency condensing units. They represent a true industry advancement that meets the needs of today's energy and environmental concerns. Designed for application in any closed loop hydronic system, the modulating capability of the **Array** matches energy input directly to fluctuating system loads.

The turn down ratio for these models is 10:1. These **Array** models provide extremely high efficient operation and are ideally suited for modern low temperature, as well as conventional heating systems.

The **Array** Models **AR 399 SE** and **AR 500 SE** operate within the following input and output ranges:

Array Model	Input Range (BTU/hr.)		Output Range (*) (BTU/hr.)	
	Minimum	Maximum	Minimum	Maximum
AR 399 SE	39,922	399,220	39,922	399,220
AR 500 SE	50,000	500,000	50,000	500,000

(*) The output of the boiler is a function of the unit's firing rate, return water temperature and BTU content of the supplied gas.

The **Array** Series of hot water boilers has been designed in compliance with the CSD-1 code.

When installed and operated in accordance with this Instruction Manual, these boilers comply with the NOx emission standards outlined in:

South Coast Air Quality Management District (SCAQMD), Rule 1146.2.

Whether used in singular or modular arrangements, the **AR 399 SE** and **AR 500 SE** offer the maximum venting flexibility with minimum installation space requirements. These Boilers are Category IV, positive pressure appliances. Single and/or multiple breeched units are capable of operation in the following vent configurations:

- Conventional, Vertical Conventional,
- Sidewall Conventional, Direct Vent,
- Vertical Sealed, Direct Vent, Horizontal.

These boilers are capable of being vented utilizing PP, CPVC, Stainless steel AL29-4C and AISI 316L vent systems.

The **Array's** advanced electronics include several selectable modes of operation offering the most efficient operating methods and energy management system integration.

! IMPORTANT: Unless otherwise specified, all descriptions and procedures provided in this Installation & Operation Manual apply to the **Array** series of boiler.

! IMPORTANT: **Array** boilers are designed for space heating using hydronic systems. Any different application (like industrial processes with heavy-duty working conditions) must be officially authorized by **RIELLO**.

1.1 Warnings & Cautions

Installers and operating personnel **MUST**, at all times, observe all safety regulations. The following warnings and cautions are general and must be given the same attention as specific precautions included in these instructions.

In addition to all the requirements included in this **RIELLO** Instruction Manual, the installation of units **MUST** conform with local building codes, or, in the absence of local codes, ANSI Z223.1 (National Fuel Gas Code Publication No. NFPA-54) for gas-fired boilers and ANSI/NFPASB for LP gas-fired boilers.

Where applicable, the equipment shall be installed in accordance with the current Installation Code for Gas Burning Appliances and Equipment, CSA B149.1, and applicable Provincial regulations for the class; which should be carefully followed in all cases.

Authorities having jurisdiction should be consulted before installations are made.

See pages 7-8 for important information regarding installation of units within the Commonwealth of Massachusetts.

! IMPORTANT: This Instruction Manual is an integral part of the product and must be maintained in legible condition. It must be given to the user by the installer and kept in a safe place for future reference.

! WARNING: Do not use matches, candles, flames, or other sources of ignition to check for gas leaks.

! WARNING: Fluids under pressure may cause injury to personnel or damage to equipment when released. Be sure to shut off all incoming and outgoing water shutoff valves. Carefully decrease all trapped pressures to zero before performing maintenance.

! WARNING: Before attempting to perform any maintenance on the unit, shut off all gas and electrical inputs to the unit.

! WARNING: The exhaust vent pipe of the unit operates under a positive pressure and therefore must be completely sealed to prevent leakage of combustion products into living spaces.

! WARNING: Electrical voltages up to 230 VAC maybe used in this equipment. Therefore the cover on the unit's power box (located behind the front panel door) must be installed at all times, except during maintenance and servicing.

! WARNING: Metal casing is an integral part of the boiler. All panels, doors and seals must be always in place, fully closed, during boiler's operation, to prevent any gas or flue leakage in case of failure.

! CAUTION: Many soaps used for gas pipe leak testing are corrosive to metals. The piping must be rinsed thoroughly with clean water after leak checks have been completed.

! CAUTION: DO NOT use this boiler if any part has been submerged under water. Call a qualified service technician to inspect and replace any part that has been subjected to water.

! WARNING: This product is a gas appliance that emits poisonous gases; such as CO (Carbon Monoxide). For this reason, it is required that CO detectors be installed in buildings where the boiler is installed. Failure to do so may result in severe injury or death.

1.2 Safety Instructions

Observe these instructions for your safety.

The burners and controls must be correctly installed and adjusted to ensure safe and economical operation of the gas boiler.

Read this installation and maintenance manual carefully and note the details on the boiler nameplate before placing the boiler in operation.

Risk of fatal injury from explosion of flammable gases

If you smell gas there is a danger of explosion.

- Never work on gas lines unless you are licensed contractor / gas fitter.
- Make sure that a licensed contractor / gas fitter installs the boiler, connects gas and vent, places the boiler in operation, connects the electrical power, and maintains and repairs the boiler.
- No open flame! No smoking! Do not use lighters.
- Prevent spark formation. Do not operate electrical switches, including telephones, plugs or door bells.
- Close main gas valve.
- Open doors and windows.
- Warn other occupants of the building, but do not use door bells.
- Call gas company from outside the building.
- If gas can be heard escaping, leave the building immediately, prevent other people from entering, notify police and fire departments from outside the building.

Risk to life from electrical shock.

- Disconnect the power supply to the boiler heating system before conducting any work on it, e.g. turn off the heating system emergency switch outside the boiler room.
- It is not sufficient just to turn off the control.
- Do not carry out electrical work unless you are qualified for this type of work.
- Before servicing, disconnect electrical power and lock out to prevent accidental reconnection.
- Observe and follow the local, state and federal installation regulations.

Risk of fatal injury from flue gas poisoning

Insufficient ventilation or combustion air availability may cause dangerous flue gas leaks and accumulation.

- Make sure that inlets and outlets are not reduced in size, restricted, or blocked.
- If faults are not corrected immediately, the boiler must not be operated until all faults have been corrected.
- Inform the system operator and/or owner of the fault and the danger in writing.

When working on the flue gas venting equipment or vent damper, leakage of flue gases may endanger the lives of people.

- Carefully observe proper operation of the vent damper. Do not start up the boiler unless the vent damper is operating properly.
- Use only genuine OEM parts when replacing parts.
- When replacing the vent damper, install the new one in the specified position.

Risk to life by poisoning by leakage of flue gases

- If the blocked vent switch trips frequently, the fault must be corrected and proper operation of the blocked vent switch test must be conducted.

Risk to life by poisoning by leakage of flue gases

- Make sure that the boiler is not equipped with a thermally controlled flue gas vent damper after the exhaust outlet on the boiler.

Risk of fatal injury from neglecting your own safety in case of emergency, such as with a fire

- Never put yourself at risk. Your own safety must always take priority.

Fire danger due to flammable materials or liquids

- Make sure that there are no flammable materials or liquids in the immediate vicinity of the boiler.
- Maintain a minimum distance of 15 inches from the boiler.

Installation and maintenance

- Observe all current standards and guidelines applicable to the installation and operation of the boiler heating system as applicable in your state or local jurisdiction.
- Clean and service the boiler system once a year. Check that the complete heating system operates correctly.
- Immediately correct all faults to prevent system damage.
- Only use original **RIELLO** spare parts. Losses caused by the use of parts not supplied by **RIELLO** are excluded from the **RIELLO** warranty
- Install and service the gas filter provided with the boiler according to the recommendations on Appendix B.

1.3 General Warning

The installation must conform to the requirements of the authority having jurisdiction or, in the absence of such requirements, to the latest edition of the National Fuel Gas Code, ANSI Z223.1/NFPA 54. In Canada, installation must be in accordance with the requirements of CAN/CSA B149.1, Natural Gas and Propane Installation Code. Where required by local, state and federal regulations, the system must comply with the American Society of Mechanical Engineers Safety Code for Controls and Safety Devices for Automatically Fired Boilers (ASME CSD-1). The hot water distribution system must comply with all applicable codes and regulations. When replacing an existing boiler, it is important to check the condition of the entire hot water distribution system to ensure safe operation. Valves external to the boiler must be fitted with T-handles and condensate piping must be installed in accordance with the State Plumbing Code.

NOTICE:

- This boiler must be installed by a licensed contractor / gas fitter. Failure to do so shall void the product warranty.
- The boiler is intended only for the use for which it was specifically designed and built. **RIELLO** is hereby excluded from any liability for damages caused to persons, animals or property resulting from installation errors, improper adjustment, maintenance or use.
- In order to ensure safety and correct operation, the installation shall always take place in full compliance with the applicable codes and following the instructions provided by the manufacturer, and must always be carried out by a licensed contractor / gas fitter only.
- The equipment must be installed in an appropriate place and in combination with appropriate systems as specified by code.
- The unit may be exposed to temperatures between 5°F (-15°C) and 158°F (70°C) in its original packaging.
- After removing the packaging check the integrity and completeness of delivery and in case of non-compliance, contact your dealer.
- If there is a water leak, disconnect the boiler from the main power supply, close the water supply and immediately call technical assistance or installer/local contractor.
- Periodically check that the condensate drain is free from obstruction, dirt, grease, or other foreign material.
- Periodically check the system pressure. System pressure should be checked when the system is in standby mode and no call for heat is present.
- Maintenance is mandatory and shall be carried out at least once a year.
- This manual shall be read carefully, in order to install and operate the boiler appropriately, and safely.
- Boiler installations, settings and service should only be performed by an experienced licensed contractor / gas fitter. End Users should only make adjustments with the assistance of a licensed contractor / gas fitter.
- Any maintenance or service before disconnecting the boiler from the main power supply is forbidden.
- Do not remove or modify safety equipment.
- Do not pull or twist the electrical wires from the boiler, even if the device is disconnected from the main power supply.
- Do not obstruct or reduce the ventilation openings.
- Do not install the unit outdoors.
- Do not leave any combustibles or containers of flammable substances in the room where the boiler is installed.
- Keep packaging material out of reach of children as it can be potentially dangerous. Dispose of packaging material as required by law.
- The opening of metal casing of the device or removing of the cover are prohibited to the end user. Any service on the boiler must be carried out by authorized personnel.
- It is prohibited to dispose the product as domestic waste. The separate disposal of the appliance avoids possible negative consequences for the environment and human health deriving from inappropriate disposal. Its materials should be recycled to achieve significant savings in energy and resources.



WARNING: RISK OF CARBON MONOXIDE POISONING OR FIRE DUE TO JOINT SEPARATION OR PIPE BREAKAGE. Ensure all of the venting system is properly supported and secured per these instructions, venting manufacturer's instructions and with the National Fuel Gas Code, ANSI Z223.1/NFPA 54, CAN/CSA B149.1, and/or applicable provisions of local building codes. Failure to do so may result in substantial property damage, severe personal injury or death.

2 PRODUCT DESCRIPTION

2.1 Description of the appliance

The Array AR SE is a condensing, pre-mixed thermal module consisting in a modulating thermal element.

It's available in two models of power: 399.220 BTU/hr (117 kW) and 500.000 BTU/hr (146.5 kW).

Optimal combustion management supports high thermal efficiencies (Over 95%) and low polluting emissions.

The boiler is designed for sealed chamber operation.

The appliance in standard configuration is for indoor installation.

The appliance's key technical features are:

- helicoidal heat exchanger with a double coil smooth stainless steel pipe, to guarantee good corrosion resistance and the option of operating with high Δt s (up to 72°F [40°C]), reducing system set-up times;
- maximum exhaust flue exit temperature 212°F [100°C];
- microprocessor management and control with self-diagnostics, shown by means of a display, and logging of main errors;
- Anti-Freeze function;
- pre-settings for room/heat demand thermostat for low and high temperature ranges;
- option to manage a CH circuit and a DHW circuit with storage tank;
- high-efficiency and high residual discharge head circulator;
- climate control function (available only when using the outdoor temperature sensor accessory).

2.2 Scope of Delivery

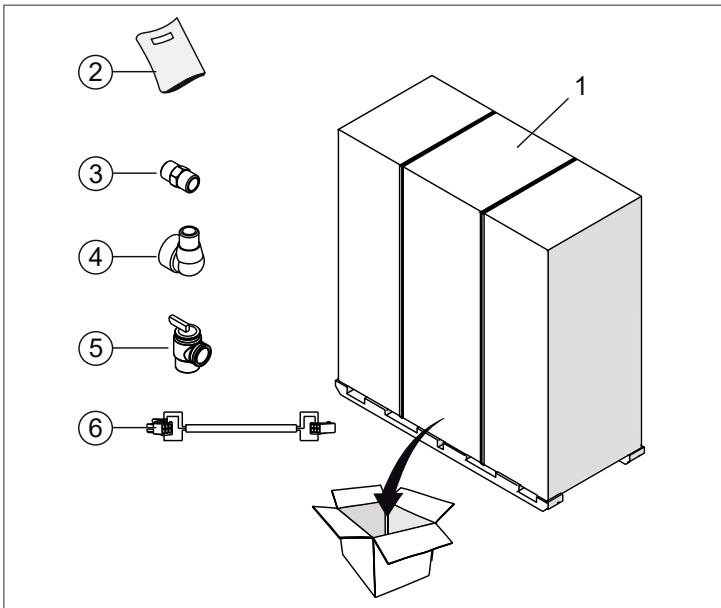

Fig. 1 Scope of delivery

Component	Q.ty	Packaging method
n° 1 Gas condensing boiler	1	Pallet
n° 2 Set of documents	1	Plastic package
n° 3 Fitting	1	Cardboard box in the boiler
n° 4 NPT steel elbow	1	Cardboard box in the boiler
n° 5 Relief valve	1	Cardboard box in the boiler
n° 6 Interface extension cable	1	Cardboard box in the boiler

2.3 Proper Use

- ▶ The **Array** boilers are designed for large residential, commercial and industrial applications.
- ▶ The **Array** boilers are delivered in compliance with CSD-1 Commercial applications.
- ▶ The appliance may only be installed in closed loop hot water central heating systems.
- ▶ Any other purpose is considered improper use. Any resulting damage is excluded from the manufacturer's warranty.
- ▶ In some heating applications like pool, spa or process water heating, a heat exchanger must be installed.

2.4 Environmental Responsibility / Disposal

Environmental responsibility is one of the fundamental company policies of the **RIELLO** Group.

We regard quality of performance, economy and environmental responsibility as equal objectives. Environmental protection laws and regulations are strictly adhered to.

To protect the environment, we use the best possible technology and materials while also taking into account economic points of view.

Packaging

All packaging materials used are environmentally-friendly and recyclable.

2.5 Emergency Shutdown

If overheating occurs or the gas supply fails to shut off, close the manual gas shutoff valve (Fig. 2) located external to the unit.

NOTE: The Installer must identify and indicate the location of the manual emergency shutoff valve.

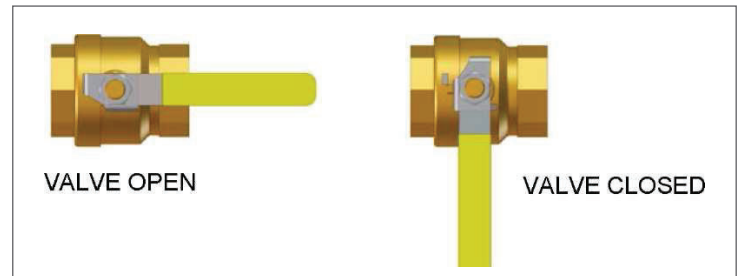

Fig. 2 Manual Gas Shutoff Valve

2.6 Prolonged Shutdown

After prolonged shutdown, the startup procedures and the safety device test procedures of this manual shall be performed to verify all system/operating parameters.

If there is an emergency, turn off the electrical power supply to the **RIELLO** boiler and close the manual gas valve located upstream of the unit. The installer must identify the emergency shut-off device.

2.7 Additional regulations for installations in the Commonwealth of Massachusetts

Boiler Installations within the Commonwealth of Massachusetts must conform to the following requirements:

- Boiler must be installed by a plumber or a gas fitter who is licensed within the Commonwealth of Massachusetts.
- Prior to unit operation, the complete gas train and all connections must be leak tested using a non-corrosive soap.
- The vent termination must be located a minimum of 4 feet above grade level. If side wall venting is used, the installation must conform to the following requirements extracted from 248 CMR 5.08 (2):

(a) For all side wall horizontally vented gas fueled equipment installed in every dwelling, building or structure used in whole or in part for residential purposes, including those owned or operated by the Commonwealth and where the side wall exhaust vent termination is less than seven (7) feet above finished grade in the area of the venting, including but not limited to decks and porches, the following requirements shall be satisfied:

1. INSTALLATION OF CARBON MONOXIDE DETECTORS

At the time of installation of the side wall horizontal vented gas fueled equipment, the installing plumber or gas fitter shall observe that a hard wired carbon monoxide detector with an alarm and battery back-up is installed on the floor level where the gas equipment is to be installed.

In addition, the installing plumber or gas fitter shall observe that a battery operated or hard wired carbon monoxide detector with an alarm is installed on each additional level of the dwelling, building, or structure served by the side wall horizontal vented gas fueled equipment. It shall be the responsibility of the property owner to secure the services of qualified licensed professionals for the installation of the hard wired carbon monoxide detectors.

- a. In the event that the side wall horizontally vented gas fueled equipment is installed in a crawl space or an attic, the hard wired carbon monoxide detector with alarm and battery back-up may be installed on the next adjacent floor level.
- b. In the event that the requirements of this subdivision cannot be met at the time of completion of installation, the owner shall have a period of thirty (30) days to comply with the above requirements; provided, however, that during said thirty (30) days period, a battery operated carbon monoxide detector with an alarm shall be installed.

2. APPROVED CARBON MONOXIDE DETECTORS

Each carbon monoxide detector as required in accordance with the above provisions shall comply with NFPA 720 and be ANSI/UL 2034 listed and IAS certified.

3. SIGNAGE

A metal or plastic identification plate shall be permanently mounted to the exterior of the building at a minimum height of eight (8) feet above grade directly in line with the exhaust vent terminal for the horizontally vented gas fueled heating appliance or equipment.

The sign shall read, in print size no less than one-half (1/2) inch in size, "**GAS VENT DIRECTLY BELOW. KEEP CLEAR OF ALL OBSTRUCTIONS**".

4. INSPECTION

The state or local gas inspector of the side wall horizontally vented gas fueled equipment shall not approve the installation unless, upon inspection, the inspector observes carbon monoxide detectors and signage installed in accordance with the provisions of 248 CMR 5.08(2)(a)1 through 4.

(b) EXEMPTIONS:

The following equipment is exempt from 248 CMR 5.08(2)(a)1 through 4:

1. The equipment listed in Chapter 10 entitled "Equipment Not Required To Be Vented" in the most current edition of NFPA 54 as adopted by the Board; and
2. Product Approved side wall horizontally vented gas fueled equipment installed in a room or structure separate from the dwelling, building or structure used in whole or in part for residential purposes.

(c) MANUFACTURER REQUIREMENTS – GAS EQUIPMENT VENTING SYSTEM PROVIDED

When the manufacturer of Product Approved side wall horizontally vented gas equipment provides a venting system design or venting system components with the equipment, the instructions provided by the manufacturer for installation of the equipment and the venting system shall include:

1. Detailed instructions for the installation of the venting system design or the venting system components; and
2. A complete parts list for the venting system design or venting system.

(d) MANUFACTURER REQUIREMENTS – GAS EQUIPMENT VENTING SYSTEM NOT PROVIDED

When the manufacturer of a Product Approved side wall horizontally vented gas fueled equipment does not provide the parts for venting the flue gases, but identifies "special venting systems", the following requirements shall be satisfied by the manufacturer:

1. The referenced "special venting system" instructions shall be included with the appliance or equipment installation instructions; and
2. The "special venting systems" shall be Product Approved by the Board, and the instructions for that system shall include a parts list and detailed installation instructions.

(e) A copy of all installation instructions for all Product Approved side wall horizontally vented gas fueled equipment, all venting instructions, all parts lists for venting instructions, and/or all venting design instructions shall remain with the appliance or equipment at the completion of the installation.

[End of Extracted Information From 248 CMR 5.08 (2)]

2.8 Identification

The products are identified by:

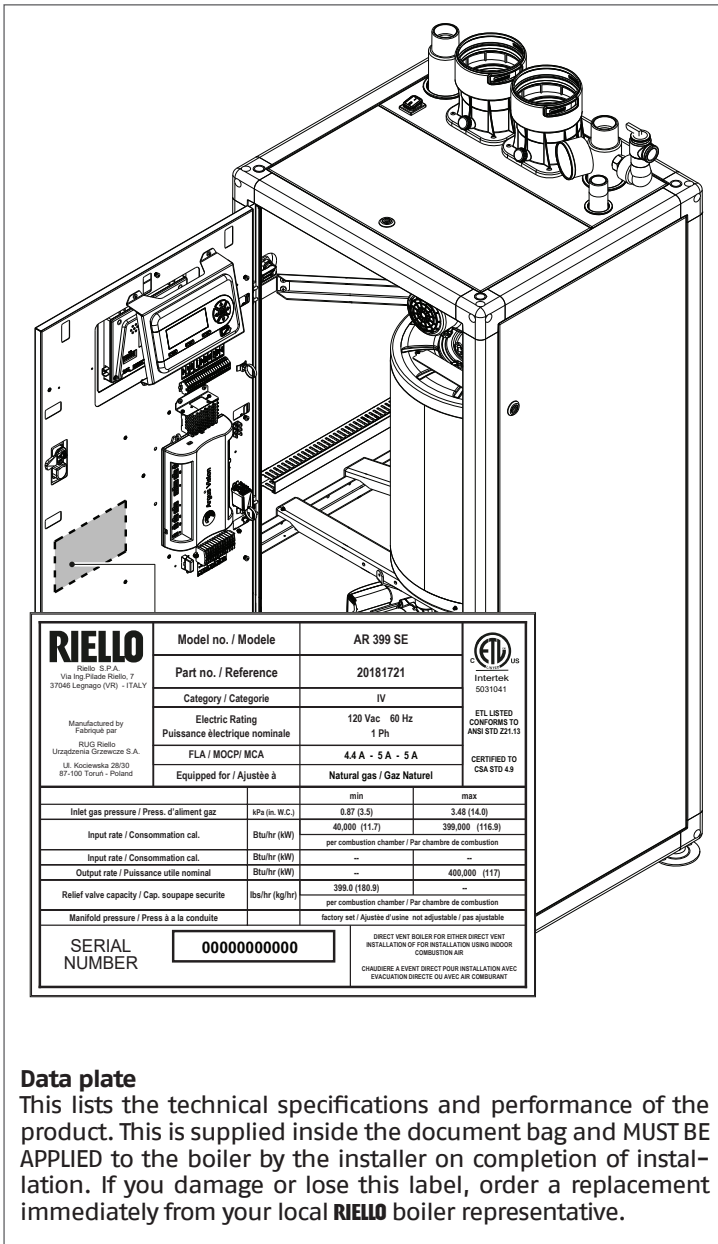

Data plate

This lists the technical specifications and performance of the product. This is supplied inside the document bag and **MUST BE APPLIED** to the boiler by the installer on completion of installation. If you damage or lose this label, order a replacement immediately from your local **RIELLO** boiler representative.

Fig. 3 Data plate

NOTE: If these plates or any other means clearly identifying the product are defaced, removed or lost, proper installation and servicing may be rendered difficult.

2.9 Dimension

Array AR SE

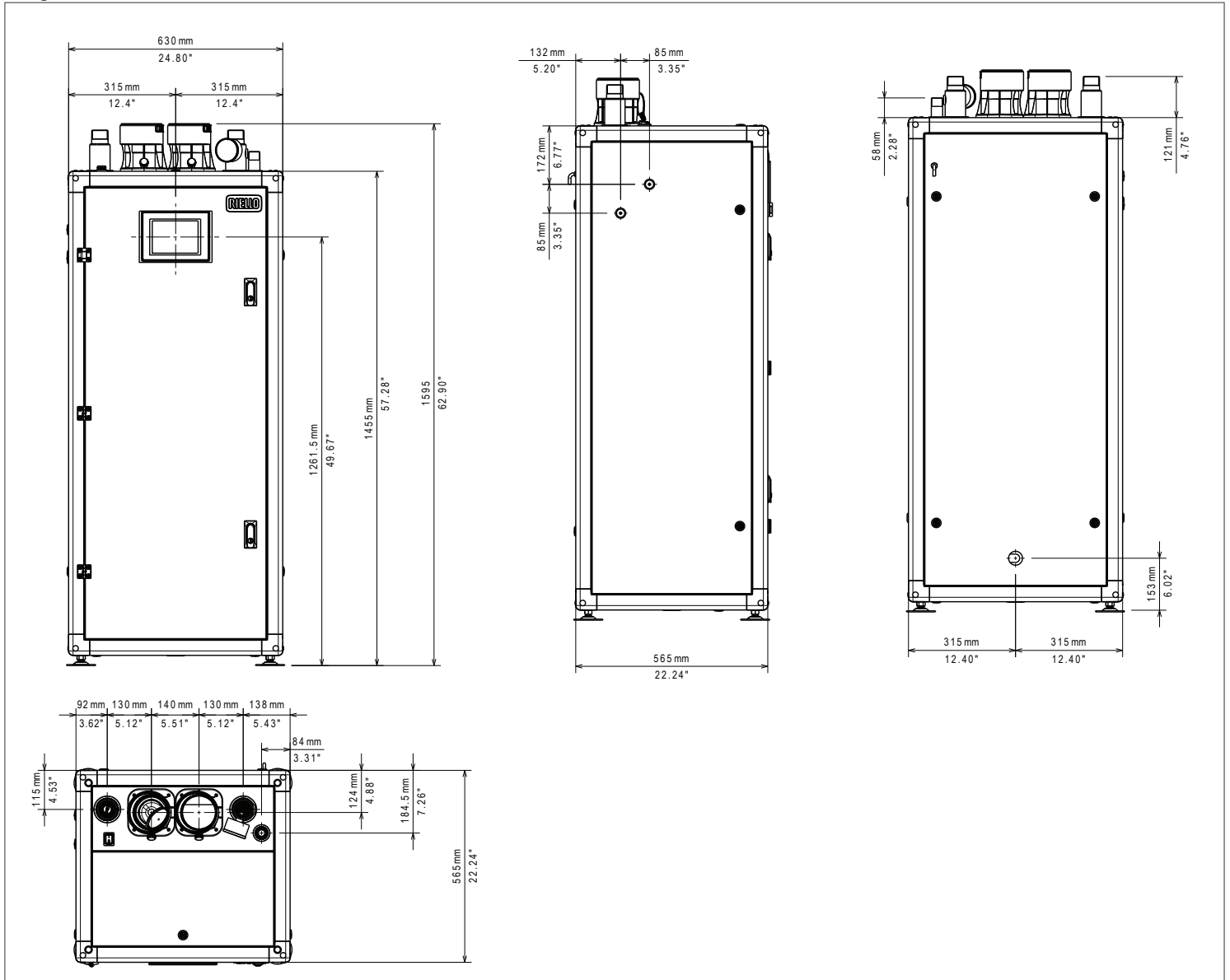

Fig. 4 Dimension

2.10 System layout

Array AR SE

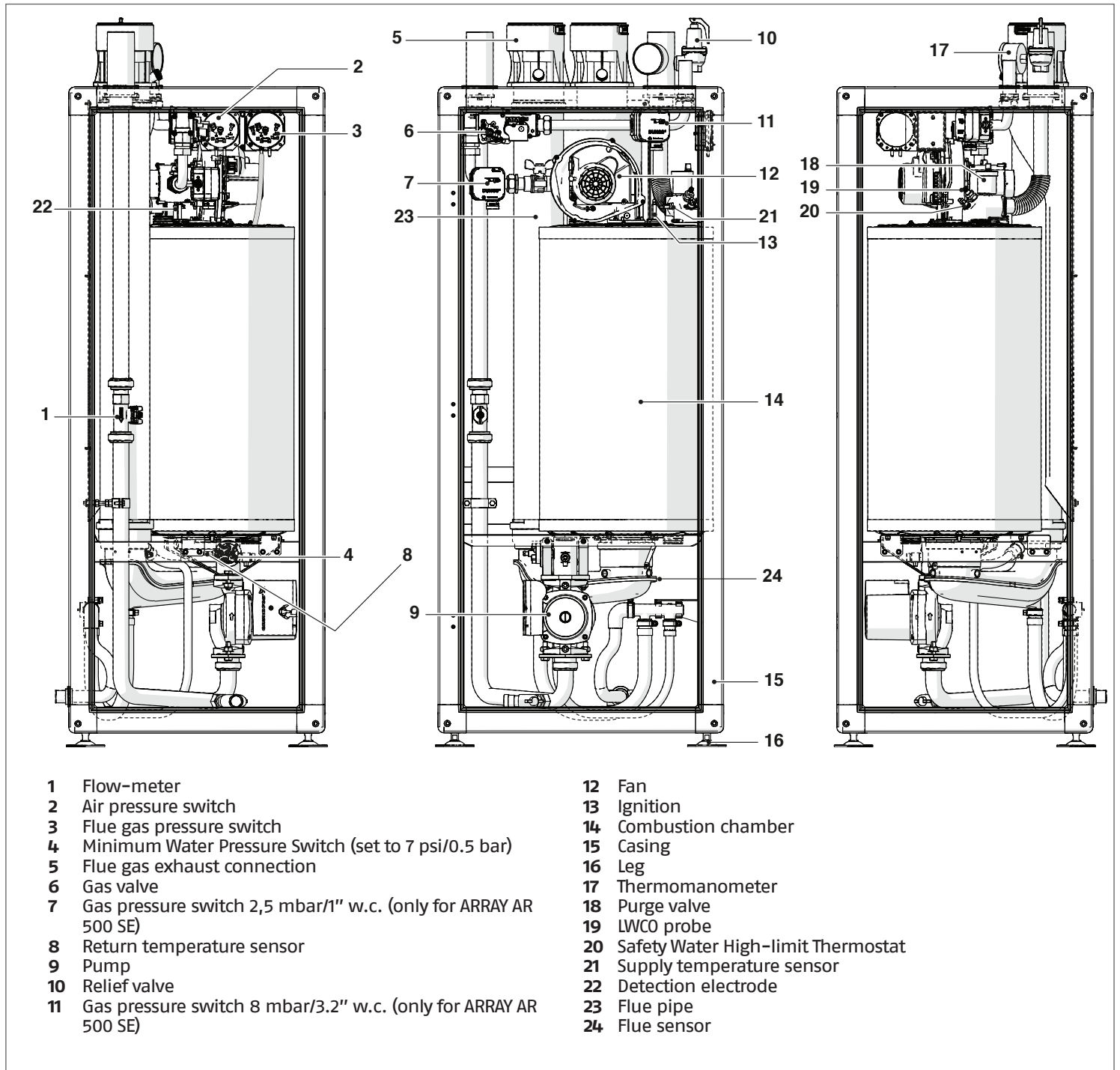
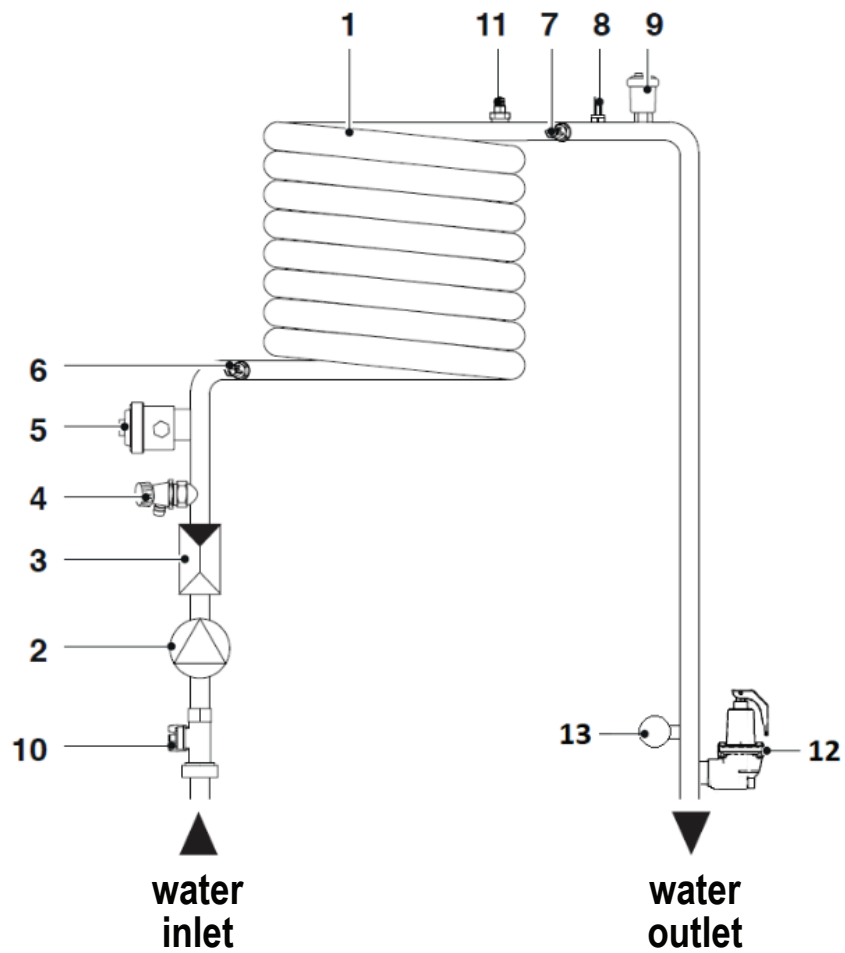

Fig. 5 System layout

2.11 Water circuit



- 1 Heat exchanger
- 2 Pump
- 3 Check valve
- 4 Drain cock
- 5 Minimum Water Pressure Switch (set to 7 psi/0.5 bar)
- 6 NTC return sensor
- 7 Safety water high-limit thermostat temperature sensor
- 8 NTC flow sensor
- 9 Automatic air vent
- 10 Flow-meter
- 11 LWCO
- 12 Safety Pressure Relief: ASME rated, 75 psig (517 kPa) setting
- 13 Mechanical Thermo-manometer
- MI Central heating supply
- RI Central heating return

Fig. 6 Water circuit

2.12 Technical specifications

	Unit	AR 399 SE	AR 500 SE
Boiler Category		ASME Sect. IV	
Type of Gas		Natural Gas, Propane*	
Max input rate	BTU/hr (kW)	399,220 (117)	500,000 (146.5)
Min input rate	BTU/hr (kW)	39,922 (11.7)	50,000 (14.6)
Turndown	Rate	10:1	10:1
Gas Connection (NPT)	Ø Inch	1"	1"
Max. NG Pressure	Inch w.c. (mbar)	13.5 (33.6)	13.5 (33.6)
Min. NG Pressure	Inch w.c. (mbar)	3.5 (8.7)	3.5 (8.7)
Max. LPG Pressure	Inch w.c. (mbar)	13.5 (33.6)	13.5 (33.6)
Min. LPG Pressure	Inch w.c. (mbar)	8 (19.9)	8 (19.9)
O ₂ Operating Range (Natural Gas)	%	4.4 - 5.8	4.4 - 5.8
CO ₂ Operating Range (Natural Gas)	%	8.5 - 9.5	8.5 - 9.5
Water Connections	Ø Inch	1" 1/2	2"
Condensate drain connection	inch (mm)	1" (25)	1" (25)
Max. Allowable Working Pressure (MAWP)	PSI (bar)	80 (5.5)	80 (5.5)
Relief Drain Connection (NPT)	Ø Inch (Ø mm)	3/4" (75)	3/4" (75)
Water Volume	Gallon (liter)	5.2 (19.5)	7.0 (26.5)
Water flow at max power (ΔT 36°F / 20°C)	GPM (m ³ /h)	21.1 4.8	26.6 6.0
Water flow at max power (ΔT 45°F / 25°C)	GPM (m ³ /h)	17.0 3.9	21.4 4.8
Vent/Air Intake Connections	Ø Inch (Ø mm)	4" 100	4" 100
Vent Materials		CPVC, PP, Stainless Steel AL29-4C	
Max operating temperature	°F (°C)	194 (90)	194 (90)
Max HE allowable temperature	°F (°C)	210 (98.9)	210 (98.9)
Ambient storage temperature	°F (°C)	5 to 158 (-15 to 70)	5 to 158 (-15 to 70)
Ambient functioning temperature	°F (°C)	32 to 120 (0 to 49)	32 to 120 (0 to 49)
Surface heat exchanger per module	SQFT (m ²)	27 (2.5)	43 (4)
Standard Listings & Approvals		ETL, ASME, AHRI, CSD-1, SCAQMD	
Electrical Req.		120V/1PH/60Hz **4.6 FLA - 5.0 MOCP - 5.1 MCA	120V/1PH/60Hz **6.2 FLA - 5.0 MOCP - 7.0 MCA
Weight (dry)	lbs (kg)	240 (109)	269 (122)
Dimension W x H x D	Inch (mm)	24.8x22.2x62.9 (630x565x1595)	24.8x22.2x62.9 (630x565x1595)

(*) For propane fuel applications, please contact factory.

(**) FLA (Full Load Amperage) – maximum current drawn by the boiler if all pumps reach rated horsepower
MOCP (Maximum Over Current Protection) – MCA (Minimum Circuit Capacity)

(***) Mounting feet may be removed during installation to reduce the overall height by 2". Feet must be re-installed once boiler is in its final installation location.

AHRI certified ratings	Unit	AR 399 SE	AR 500 SE
Input	MBH	399.2	500.00
Heating Capacity	MBH	383.00	481.00
AFUE	%	96,1	96,1
Combustion Efficiency	%	96,1	96,1
CO2	%	8.5 – 9.5	8.5 – 9.5

2.13 Efficiency Curves

ARRAY AR 399 SE - 500 SE

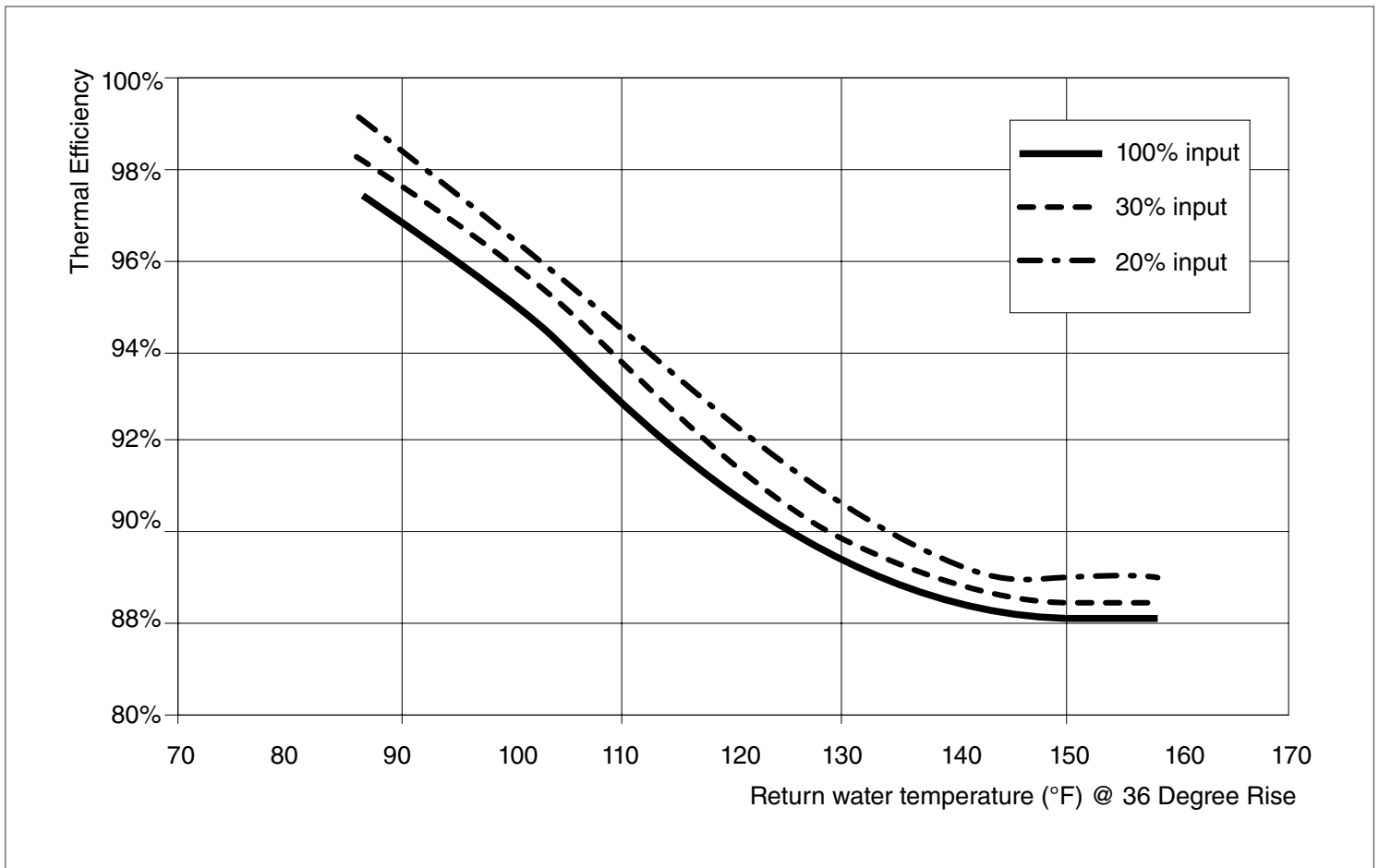

WATER PRESSURE DROP

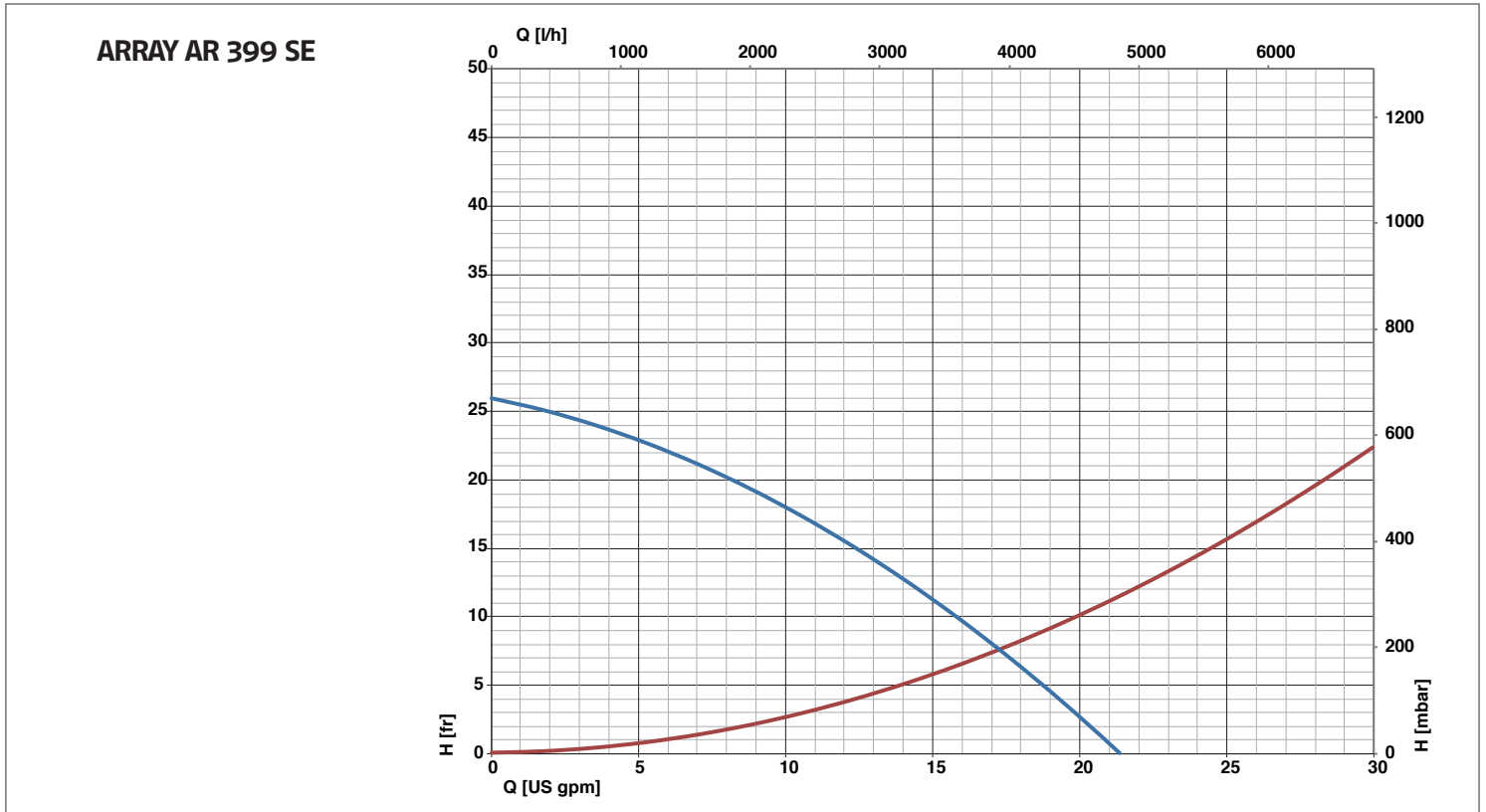

Fig. 7 Water pressure drop Array AR 399 SE

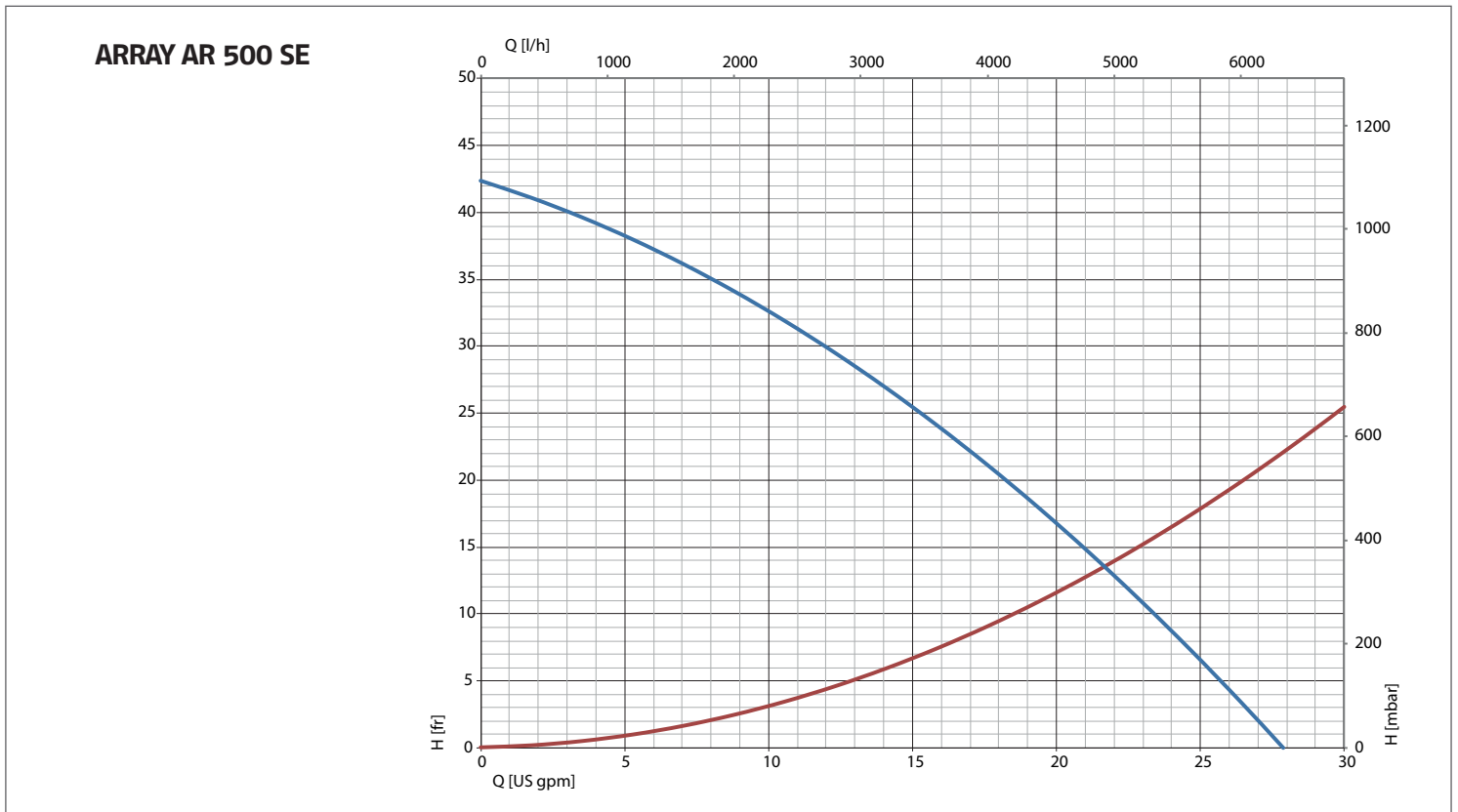



Fig. 8 Water pressure drop Array AR 500 SE

3 REGULATIONS AND GUIDELINES

 **NOTE:** Observe all rules, regulations, standards and guidelines applicable to the installation and operation of this appliance in your country.

 **NOTE:** Valves external to the boiler must be fitted with T-handles and condensate piping must be installed in accordance with the local plumbing code.

3.1 Compliance with standards and regulations

The installation must conform to the requirements of the authority having jurisdiction or, in the absence of such requirements, to the latest edition of the National Fuel Gas Code, ANSI Z223.1./NFPA 54. In Canada, installation must be in accordance with the requirements of CAN/CSA B149.1, Natural Gas and Propane Installation Code.

This condensing gas boiler complies in its design and mode of operation with the American National Standard ANSI Z21.13/CSA4.9, latest edition for Gas Fired Low Pressure Steam and Hot Water Boilers.

Other confirmed approvals and certifications are indicated by labels on the boiler.

Where required by the authority having jurisdiction, the installation must conform to the Standard for Controls and Safety Devices for Automatically Fired Boilers, ANSI/ASME CSD-1.

Install CO detectors per local regulations. Boiler requires yearly maintenance (see "Appendix B - Maintenance").

3.2 Operating limits of the boiler

The heat exchanger has been designed and certified in accordance with the ASME Boiler and Pressure Vessel Code, Section IV.

The hot water distribution system must comply with all applicable codes and regulations. When replacing an existing boiler, it is important to check the condition of the entire hot water distribution system to ensure safe operation. Common practice calls for inspecting an existing system in its entirety and bringing it up to code. All pipework should be properly cleaned and flushed.

4 INSTALLATION

4.1 Introduction

This Chapter provides the descriptions and procedures necessary to unpack, inspect and install the **RIELLO Array Boiler Model AR 399 SE – AR 500 SE**.

4.2 Receiving the Unit

Each **Array** Boiler System is shipped as a single crated unit. The unit must be moved with the proper lifting equipment for safety and to avoid equipment damage. The unit should be completely inspected for evidence of shipping damage and shipment completeness at the time of receipt from the carrier and before the bill of lading is signed.

NOTE: **RIELLO** is not responsible for lost or damaged freight. Any visual damage to the packaging materials must be reported to the delivering carrier.

4.3 Unpacking

Carefully unpack the unit, pay particular attention not to damage the unit enclosure when cutting away packaging materials. After unpacking, a close inspection of the unit should be made to ensure that there is no evidence of damage. The freight carrier should be notified immediately if any damage is detected.

The following accessories come standard with each unit and are either packed separately within the unit's shipping container or are factory installed on the unit:

- Pressure/Temperature Gauge
- ASME Pressure Relief Valve

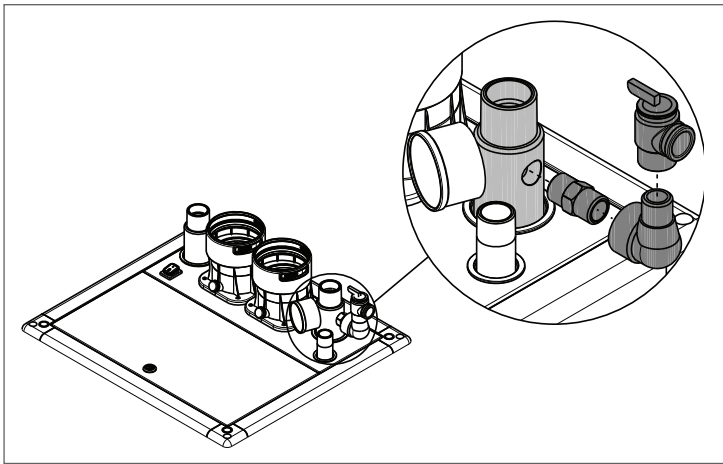

Fig. 9 ASME Pressure Relief Valve

When optional accessories are ordered, they may be packed within the unit's shipping container, factory installed on the unit, or packed and shipped in a separate container. Any standard or optional accessories shipped loose should be identified and stored in a safe place until ready for installation or use.

4.4 Site Preparation

Ensure that the site selected for installation of the **Array AR SE** Boiler includes:

- Access to AC Input Power at 120VAC, single phase, 60Hz
- Access to Natural Gas line at a recommended minimum pressure of 8 inches w.c. for 399.220 BTU/hr (117 kW) for **Array AR 399 SE** and 500.000 BTU/hr (146.5 kW) for **Array AR 500 SE**.
- The boilers should be mounted on a concrete service/housekeeping pad 3,5-4" in height.
- The boiler should be located close to a floor drain in an area where leakage from the appliance or connections will not cause damage to the adjacent area or lower floor levels in the building.

4.4.1 Installation clearances

The **Array** model **AR 399 SE – AR 500 SE** are packaged in an enclosure having identical footprint but different height. The unit must be installed with the prescribed clearances for service. The minimum clearance dimensions, required by **RIELLO**, are listed below.

However, if Local Building Codes require additional clearances, these codes shall supersede **RIELLO**'s requirements.

Recommended minimum clearances for installation and servicing:

- Sides: 10 inches
- Front: 40 inches
- Rear: 5 inches
- Top: 20 inches

The minimum surface of ventilation openings is 3.2ft² (0.3m²) for gas fuel heating systems.

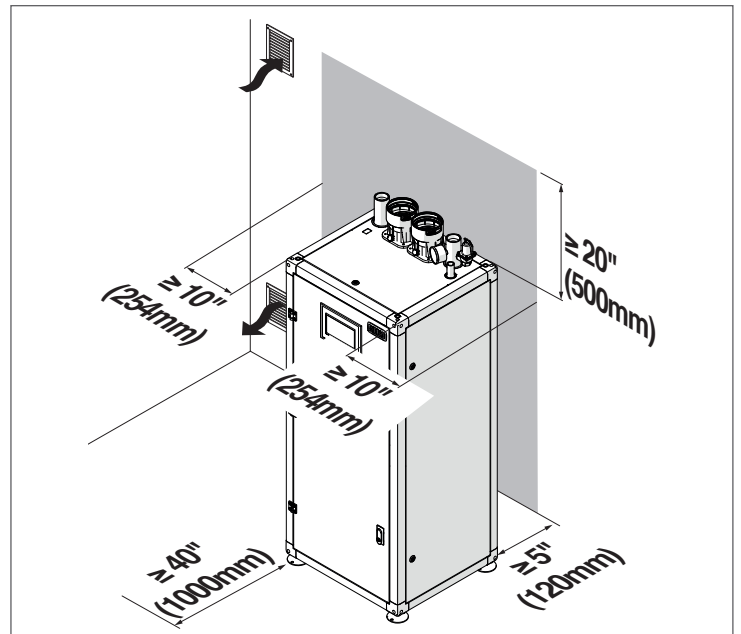

Fig. 10 Clearances (dimensions in inches [mm])

All gas piping, water piping and electrical conduit or cable must be arranged so that they do not interfere with the removal of any panels, or inhibit service or maintenance of the unit.

⚠ WARNING: Keep the unit area clear and free from all combustible materials and flammable vapors or liquids.

⚠ CAUTION: While packaged in the shipping container, the unit must be moved by pallet jack or forklift from the **SIDE ONLY**.

FOR MASSACHUSETTS ONLY:

For Massachusetts installations, the unit must be installed by a plumber or gasfitter licensed within the Commonwealth of Massachusetts. In addition, the installation must comply with all requirements specified in Warning & Cautions page 5. See pages 7 and 17 for additional details.

4.4.2 Setting the Unit

Remove the top and side cardboard panels, the plastic film and the polystyrene sheets. Remove the lag screws securing the unit to the shipping skid. Lift the unit off the shipping skid with a forklift and position it on the floor in the desired location.

⚠ WARNING: When lifting or moving the boiler: do not attempt to manipulate the boiler using the top water flanges or any other component of the boiler.

⚠ WARNING: When lifting or moving the boiler with a forklift: make sure the forks are longer than the boiler size (width or depth) so that the lifting forks stick out as Fig. 11.

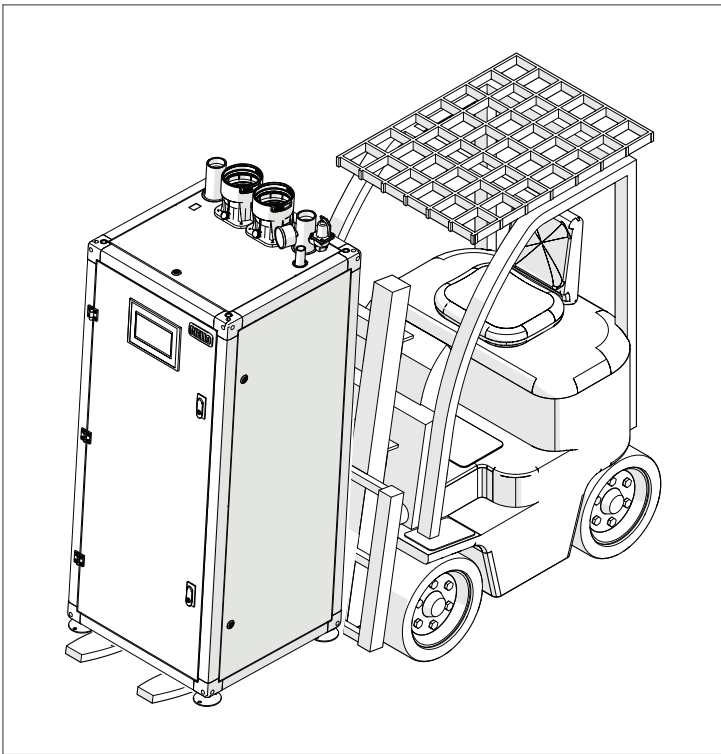

Fig. 11 Forklift Handling

If a crane is required, the boiler must be lifted through bands.

⚠ WARNING: When lifting the boiler with crane: use bands or straps, no chains. Bands must comply with federal, state and local rules.

In multiple unit installations, it is important to plan the position of each unit in advance. Sufficient space for piping connections and future service/maintenance requirements must also be taken into consideration. All piping must include ample provisions for expansion.

The unit must be installed on a concrete service pad (3.5" - 4" height), with no gradient in any direction, to ensure proper condensate and water drainage (see Fig. 12). If anchoring the unit refer to Fig. 13 and Fig. 14 for anchor locations.

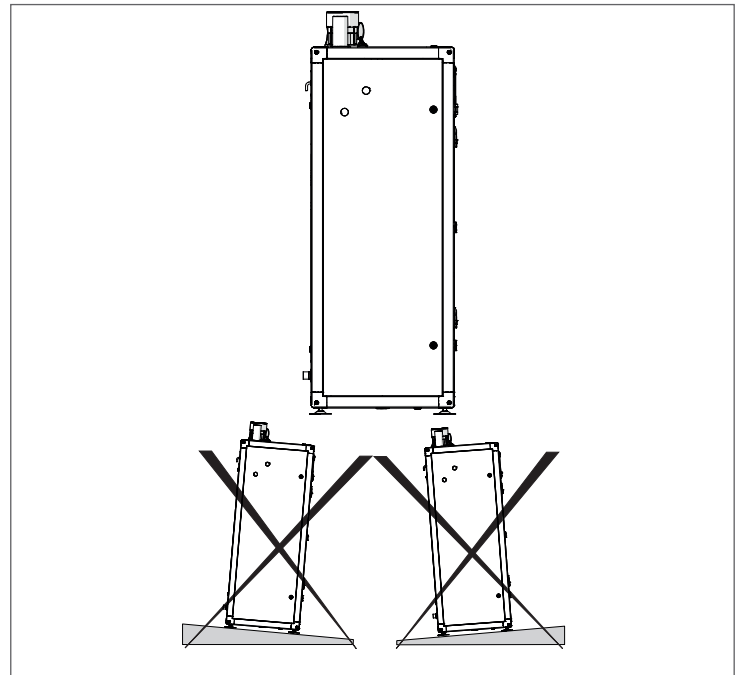

Fig. 12 Installation

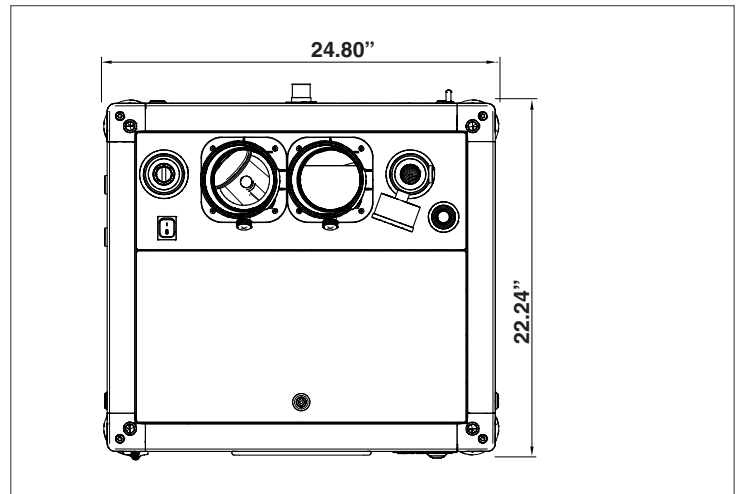

Fig. 13 Anchoring bolt

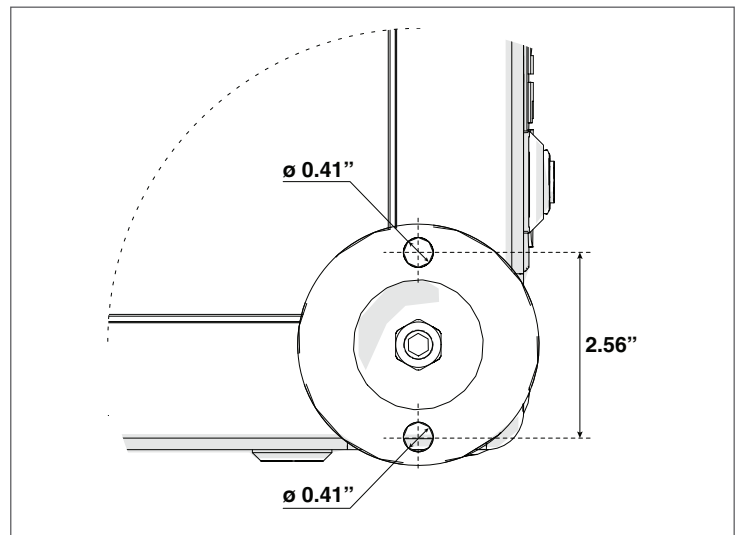

Fig. 14 Anchoring bolt detail

4.5 Installation in older systems and systems requiring modifications

When installing these boilers in older systems or systems requiring modifications, always perform the following checks:

- Make sure that the flue is able to withstand the temperature of the combustion gases and that it has been designed and made in compliance with applicable standards. The flue must also be as straight as possible, sealed, insulated and not blocked or choked. See section "Combustion gas exhaust" for any additional information.
- Make sure that the electrical supply system has been installed by a qualified electrician in compliance with applicable standards
- Make sure that the fuel feed line and any storage tank are made and installed in compliance with applicable standards
- Make sure that expansion tank(s) are big enough to contain the additional volume generated by thermal expansion
- Make sure that the flow rate, head and direction of flow of the pumps are suitable and correct
- The system has been washed, cleaned of mud and grime and water seals have been checked
- A treatment system is fitted when the supply/refill water has values other than those indicated in section "Water Quality Guidelines"

⚠ NOTE: The manufacturer declines all responsibility for damage caused by incorrectly constructed flue systems.

4.6 Boiler Location

- This boiler is suitable only for indoor installations.
- To operate properly and safely, this boiler requires a continuous supply of air for combustion. Install this boiler in a clean, dry location with adequate air supply.
- Do not locate this boiler in an area where it will be subject to freezing.
- The boiler should be located close to a floor drain in an area where leakage from the appliance or connections will not result in damage to the adjacent area or to lower floors in the structure.
- DO NOT install this appliance in any location where gasoline or flammable vapors are likely to be present.
- DO NOT install this appliance on top of carpet or combustible flooring.
- Appliance must be installed on a concrete level service pad (3.5" - 4" minimum recommended height).
- Maintain required clearances 2" (50.8mm) from combustible surfaces.

4.7 Water connection

⚠ NOTE: Before connecting the boiler the protection plugs must be removed from the supply, return and condensate drain pipes.

⚠ CAUTION: Before connecting the boiler, it is necessary to clean the system. This step is required when the appliance replaces another one on pre-existing systems.

In order to carry out this cleaning activity, if the old boiler is still installed on the system, it is advisable to:

- add a de-scaling additive.
- operate the system with the boiler on for around 7 days.
- discharge the dirty system water and flush the system one or more times with clean water.

If the system is very dirty, repeat the last procedure one more time. If the old boiler is not present or available, use a pump to circulate the water + additive through the system for about 10 days and perform a final washing as described in the previous paragraph.

Once the cleaning has been completed, it is recommended to add a suitable protective fluid to the system's water before installing the boiler.

In order to clean the heat exchanger's built-in water system, please contact your local **RIELLO** boiler distributor for further assistance.

⊖ CAUTION: Do not use incompatible liquid detergents, including acids (for instance, chloridric acid and similar) in any concentration.

⊖ CAUTION: Do not subject the heat exchanger to cyclical pressure changes because fatigue stress is very dangerous for the integrity of system components.

The boiler, when used in connection with a refrigeration system, must be installed so the chilled medium is piped in parallel with the boiler with appropriate valves to prevent the chilled medium from entering the boiler.

The boiler piping system of a hot water boiler connected to heating coils located in air handling units where they may be exposed to refrigerated air circulation must be equipped with flow control valves or other automatic means to prevent gravity circulation of the boiler water during the cooling cycle.

4.7.1 Minimum Water Flow (Heat Exchanger Protection)

This unit is self-protected against low water flow. A flow meter continuously monitors the water flow to each module. If the water flow decreases below the minimum stated, the burner automatically shuts off.

⚠ NOTE: Make sure that the pump in the system is free, bled and rotate in the right direction.

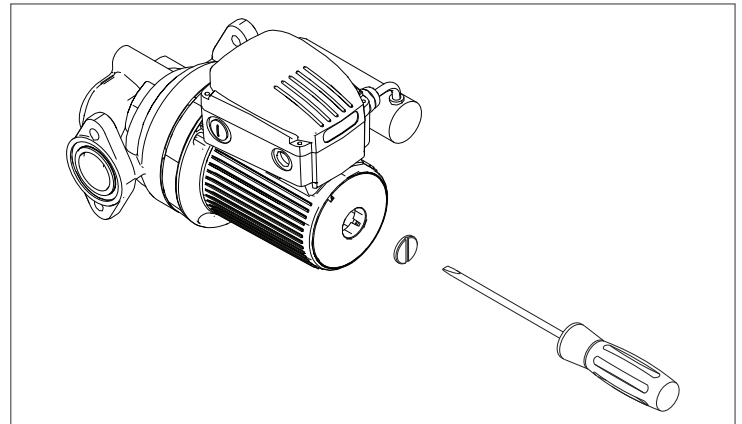

Fig. 15 Rotation pump check

⚠ WARNING: Bleed the air from the system and pump, otherwise it will be damaged beyond repair.

4.7.2 Heating System Pressure Test

If the pressure inside the heating circuit falls below the minimum pressure for the system (7.5 PSI), the appliance switches off and the 905PB inner display shows "Low water pressure" to indicate that it is necessary to restore the correct pressure.

Open the filling valve and check the pressure on the temperature/pressure gauge of Fig. 16.

The error will disappear when the pressure is back at the right value. To prevent accidental relief valve openings, fill the heating circuit slowly.

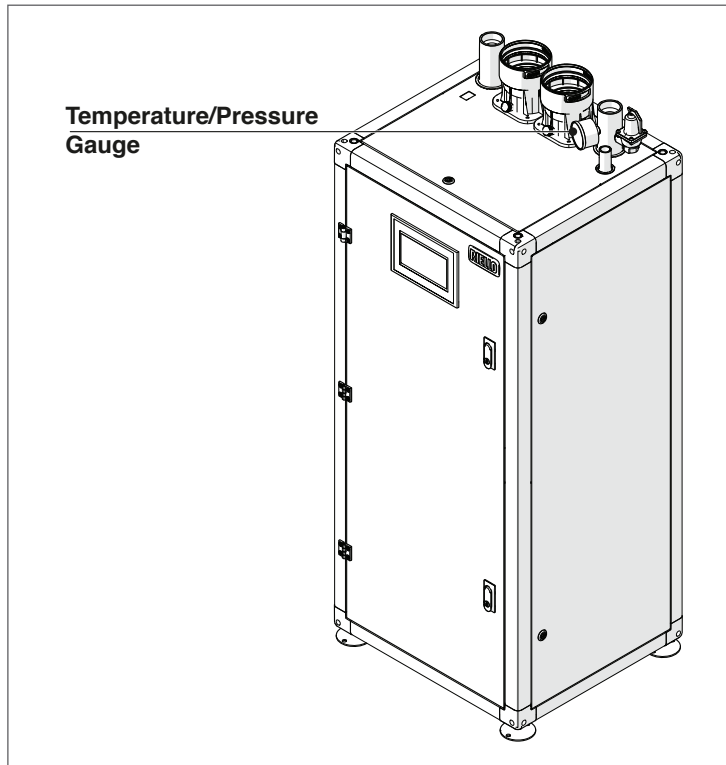

Fig. 16 Temperature/Pressure Gauge location

4.8 Water Quality Guidelines

Excessive water hardness causing a lime buildup in the stainless steel coils or tubes is not a fault of the appliance and is not covered by warranty. Water hardness must fall within the following limits:

Parameters	Units	Value
General feature		Colorless, no sediment
PH value	PH	Min 6.5; Max 9
Dissolved Oxygen	mg/l	< 0,05
Total iron (Fe)	mg/l	< 0,3
Total copper (Cu)	mg/l	< 0,1
Na ₂ SO ₃	mg/l	< 10
N ₂ H ₄	mg/l	< 3
PO ₄	mg/l	< 15
CaCO ₃	ppm	Min 50; Max 150
Trisodium Phosphate	ppm	absent
Chlorine	ppm	< 100
Pressure	PSI	Min 7.25; Max 80
Glycol	%	Max 50% (only propylene glycol)

- Avoid an automatic water fill system.
- Use only untreated water to fill the system.
- Do not use TSP (tri-sodium phosphate).
- Do not use fill water treated with salt bedding type exchangers (ion exchanger).

- Consult a local water treatment specialist for recommendations if any of the above table is outside the stated ranges.
- When using oxygen permeable PEX, the system must be separated from the boiler by a heat exchanger.
- A correctly sized and working expansion vessel must be installed.
- Excessive flow can cause erosion damage to the heat exchanger.

⚠ CAUTION: For freeze protection use only propylene glycol, with scale inhibitors, with a maximum volume [concentration] of 50% of glycol. Frost protection and inhibitor level has to be checked annually during the regular scheduled maintenance of the condensing boiler.

⚠ CAUTION: The boiler, when used in connection with a refrigeration system, must be installed so the chilled medium is piped in parallel with the boiler with appropriate valves to prevent the chilled medium from entering the boiler.

⚠ CAUTION: The boiler piping system of a hot water boiler connected to heating coils located in air handling units where they may be exposed to refrigerated air circulation must be equipped with flow control valves or other automatic means to prevent gravity circulation of the boiler water during the cooling cycle. A minimum water pressure is required for optimum performance. Minimum water pressure required: 7.25 psi (0.5 bar).

4.9 Safety devices

All appliance functions are electronically controlled by a dual processor technology board.

Any malfunction results in the appliance being shut down and the automatic closure of the gas valve.

The following is installed on the CH water circuit:

- **Safety high-limit thermostat.**
- **Flow sensor** capable of monitoring the main heating circuit's flow on an ongoing basis and of stopping the appliance in the event of insufficient flow.
- **Temperature sensors** on supply and return lines that measure the temperature difference (Δt) between input and output fluid and allow the boiler to fire when a demand is made.
- **Minimum Water Pressure Switch** (set to 7 psi/0.5 bar).
- **LWCO.**

The following is installed on the combustion circuit:

- **Gas solenoid** with pneumatic gas flow compensation depending on the suction line's air flow rate.
- **Ignition/detection electrode.**
- **Flue gas temperature sensor.**
- **Flue gas pressure switch**
- **Air pressure switch**
- **Condensate pressure switch**

⚠ WARNING: The triggering of safety devices indicates the malfunction of a potentially hazardous situation. Therefore, contact a service agency immediately. After a brief pause, it is possible to try and restart the appliance (see section "6.1 Boiler Startup Procedure" page 29).

⚠ WARNING: Safety devices must be replaced a qualified installer, service agency or gas supplier, using only original parts. Refer to the spare parts catalogue supplied with the appliance. After making the repair, check that the appliance is working properly.

⊖ WARNING: The appliance must not be put in service, even temporarily, when tampered safety devices are not in operation or have been with.

⚠ WARNING: A hot water boiler installed above the radiation level or as required by the Authority having jurisdiction, must be provided with a low water cutoff device either as part of the boiler or at the time of boiler installation.

4.10 High Limit Safety Switch

A high limit safety switch is installed on each heat exchanger of the boiler. To simulate a high limit lockout at 203°F (95°C) go to the relevant Module screen, press 'Module Test', then 'High Limit Test' button.

The control will display "MN: Max. Thermostat Lock Error".

At this point press the reset button on the Module screen to restart the module.

4.11 Low Water Cutoff

A low water protection is installed at heat exchanger level.

Module level:

A Low Water Cut Off (LWCO) sensor is installed on top of the supply fitting of each heat exchanger. To check its functionality, go to the HMI touchscreen, access the Module screen (see section 7.3.2), push MODULE TEST, then LWCO TEST button and confirm. The error message "LWCO2 error" will appear on the screen.

At this point press the Reset button. The error will turn off.

4.12 Pressure Relief Valve installation

The **Array AR SE** has a pressure relief valve supplied with the boiler. Connect the valve hydraulically on the heating supply connection and in vertical position.

This device is designed for emergency safety relief and shall not be used as an operating control.

⚠ WARNING: To avoid water damage or scalding due to relief valve operation:

- The discharge line must be connected to relief valve outlet and run to a safe place of disposal. Terminate the discharge line in a manner that will prevent possibility of severe burns or property damage.
- The discharge line must be as short as possible and be the same size as the valve discharge connection throughout its entire length.
- The discharge line must pitch downward from the valve and terminate at least 6" (152 mm) above the floor drain where any discharge will be clearly visible.
- The discharge line shall terminate through plain (unthreaded) pipe. The discharge line material must conform to local plumbing code or A.S.M.E. requirements.
- No shutoff valve shall be installed between the relief valve and the boiler, or in the discharge line.
- Do not pipe the discharge to any place where freezing could occur.
- Do not plug or place any obstruction in the discharge line.
- Test the operation of the valve after filling and pressurizing system by lifting the lever. Make sure the valve discharges freely. If the valve fails to operate correctly, replace it with a new relief valve.
- For boilers installed with only a pressure relief valve, the indirect tank (if used) must have a temperature and pressure relief valve installed. This relief valve shall comply with the standard for Relief Valves for Hot Water Supply Systems, ANSI Z21.22/CSA4.4.
- Failure to comply with the above guidelines could result in the failure of the relief valve to operate, resulting in the possibility of severe personal injury, death or substantial property damage.
- For safe operation of the appliance, the relief valve must not be removed or plugged.

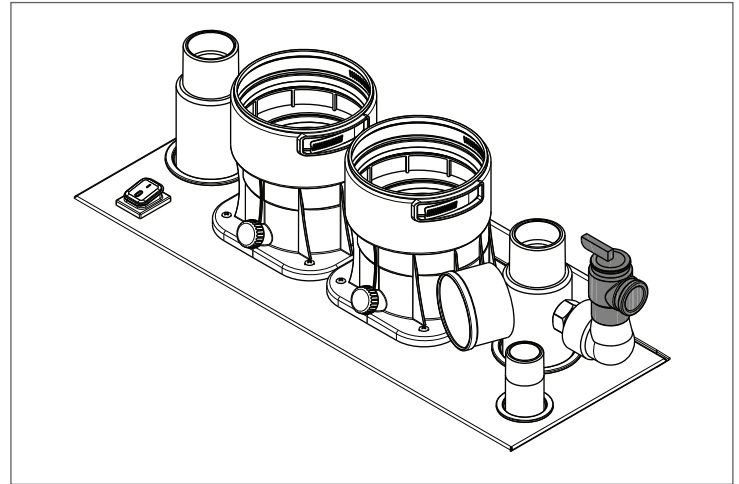

Fig. 17 Relief valve

Maintenance of the relief valve

⚠ CAUTION : The valve lever must be operated at least once a year by qualified personnel during annual maintenance to insure that water-ways are clear.

Certain natural occurring mineral deposits may adhere to the valve, rendering it inoperative.

When manually operating the lever, water will discharge and precautions must be taken to avoid contact with hot water to avoid water damage.

Before operating the lever, check to see that a discharge line is connected to this valve directing the flow of hot water from the valve to drain otherwise personal injury may result. If no water flows, the valve is inoperative. Call a qualified plumber immediately.

Pressure relief valve should be inspected at least once every three years by a licensed plumbing contractor or authorized inspection agency, to insure that the product has not been affected by corrosive water conditions and to insure that the valve and discharge line have not been altered or tampered with illegally.

Certain naturally occurring conditions may corrode the valve or its components over time, rendering the valve inoperative.

Such conditions are not detectable unless the valve and its components are physically removed and inspected.

Do not attempt to conduct this inspection on your own. Contact your plumbing contractor for a reinspection to assure continuing safety.

⚠ WARNING : Failure to reinspect this valve as directed could result in unsafe pressure buildup which can result in serious injury or death and/or severe property damage.

4.13 Condensate Drain and Piping

The **Array AR SE** is designed to condense water vapor from the flue products.

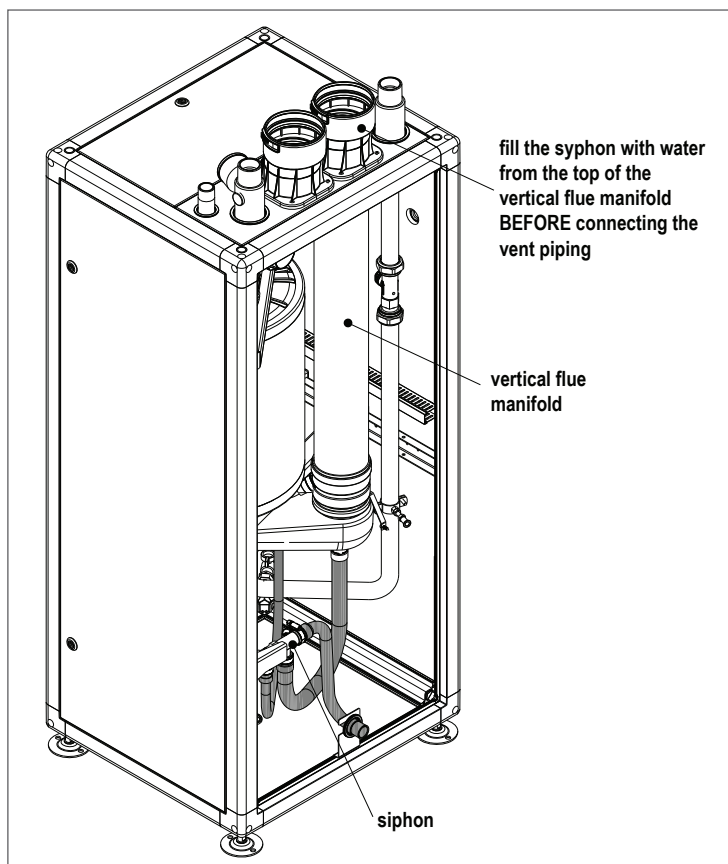

Fig. 18 Condensate drain and piping

⚠ WARNING: At the Start-up and after prolonged shutdown of the boiler, the condensate traps and the syphon must be filled with water prior to restarting it, otherwise combustion gases may enter the room with a risk of an excessive level of carbon monoxide.

- The installation must have provisions for suitable drainage or collection of the condensate exiting the boiler traps.
- The condensate water shall be discharged at atmospheric pressure, by dripping into a suitable drain, and shall be neutralized prior to draining per local/national codes.
- The condensate drain tube must pitch away from the boiler (1/4" slope per foot) and must never reduce its diameter downstream.
- Never use copper pipes or other material not intended for the specific purpose, because the acidic nature of the condensate will cause a rapid deterioration of the unsuitable piping and/or exposed components.
- Check that the condensate drain pipe is adequately sloping towards the discharge point avoiding high points, which can inhibit the flow of the condensate. The condensate pipe must be installed in such a way so as to avoid the freezing of any liquid.

⚠ WARNING: Verify condensate disposal / neutralization is in accordance with local, state and federal regulations.

4.14 Gas connections

Installation of the boiler and gas connection must comply with all applicable codes and regulations imposed by the national, Federal or local authorities and bodies. If no specific requirements are defined, in the USA, the latest edition of the National Fuel Gas Code ANSI Z223.1/NFPA 54 must be complied with. In Canada, installation must be in accordance with the requirements of CAN/CSA B149.1, Natural Gas and Propane Installation Code. Ensure the gas line is sized adequately to deliver gas to the burner. Before making the connection, check that:

- ⚠** The gas type is suitable for the appliance.
- ⚠** If the appliance needs to be adapted for use with another gas fuel, refer to Appendix A. For further information please contact your local **RIELLO** distributor.
- ⚠** Ensure the piping is thoroughly clean.
- ⚠** The gas meter's flow rate is capable of ensuring the simultaneous use of all the appliances connected to it. The appliance's connection to the gas supply line must be carried out in accordance with the latest edition of the National Fuel Gas Code ANSI Z223.1/NFPA 54, in the USA, and CAN/CSA B149.1, Natural Gas and Propane Installation Code, in Canada as well as local regulations.
- ⚠** Intake pressure with the appliance in the off position has the following reference values:
 - Natural Gas: optimal pressure 7" w.c.
 - Liquid Propane Gas (LPG): optimal pressure 11" w.c.
- ⚠** The type of gas and supply pressure for which the unit is configured is listed on the rating label. The **Array AR SE** boilers can operate using one of the following two gases:

NATURAL GAS

 - Maximum supply pressure = 13.5" w.c. (33.6 mbar).
 - Minimum supply pressure = 4" w.c. (10 mbar).

PROPANE (LP) GAS

 - Maximum supply pressure = 13.5" w.c. (33.6 mbar).
 - Minimum supply pressure = 8" w.c. (19.9 mbar).

⊖ WARNING: Do not use any fuels with this product other than the fuel it is intended to be used with, either Natural Gas or LPG.

⚠ Ensure the gas lines are vented, bled in accordance to ANSI Z223.1/NFPA 54, National Fuel Gas Code and/or CAN/CSA B149.1, Natural Gas and Propane Installation Code.

While it is normal for the inlet pressure to decrease while the appliance is in operation, it is advisable to verify that no excessive pressure fluctuations take place. In order to limit the extent of these types of variations, the diameter of the gas supply line to be used must be assessed based on the length and the pressure drops of the line itself, from the meter to the boiler.

⚠ WARNING: If fluctuations in the gas distribution pressure are encountered, it is recommended to install an appropriate pressure regulator upstream of the appliance's gas inlet. For LPG gas supply, all the necessary precautions must be taken in order to prevent the gas from freezing in the case of extremely low outdoor temperatures.

If the gas distribution network contains solid particles, install a filter on the fuel supply line. When selecting it, consider that pressure drops due to the filter should be as low as possible.

⚠ CAUTION: The boiler and its individual shut off valve must be disconnected from the gas supply piping system during any pressure testing of that system at test pressures in excess of 1/2 psi (3.5 kPa).

⚠ A sediment trap must be provided upstream of the gas controls.

⚠ A gas shutoff cock shall be located upstream of the boiler on the gas supply line.

⚠ On completion of the installation, check that all joints are sealed.

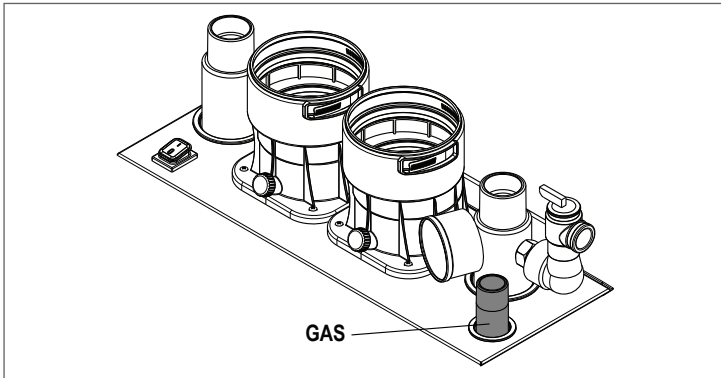

Fig. 19 Gas inlet

DESCRIPTION	Array AR 399 SE	Array AR 500 SE	
Gas inlet	1" NPT	1" NPT	∅

4.15 Adjusting and Setting O₂ Limits

- Insert a combustion analyzer probe into the test port as shown in Fig. 20;
- Go to the Touchscreen and access the Module screen (as described on "7.3.2 Module Screen" page 33) relevant to the module under analysis;
- Press "MODULE TEST" button;
- Press "HIGH POWER" button.

Wait 2 or 3 minutes to reach steady state conditions and record the O₂ value.

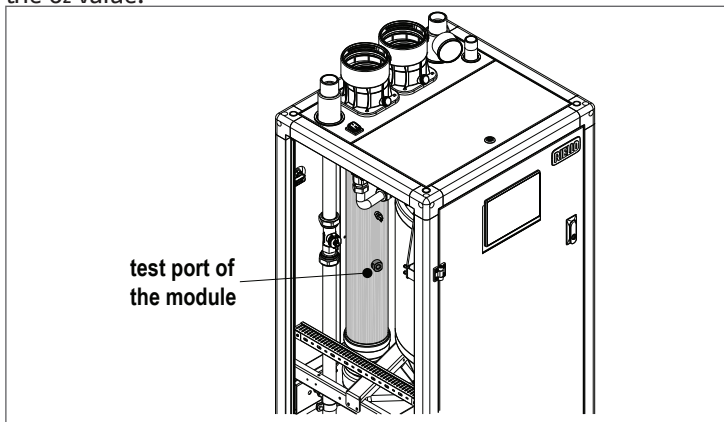

Fig. 20 Test Port for Combustion Analysis (available on each individual heat exchanger)

To adjust the O₂ value at high-fire turn the screw "A" (rotate clockwise to decrease O₂) as shown in Fig. 21. An allen type wrench is necessary for this adjustment.

Verify that the value of O₂ is stable and within the range indicated in the following table (be careful to make small changes and confirm that the value is stable before making additional adjustment).

Press "LOW POWER": the fan will run at the minimum speed.

To adjust the O₂ value at the minimum input, turn the screw "B" (rotate clockwise to decrease O₂) as shown in Fig. 21 using a Torx T40 screwdriver.

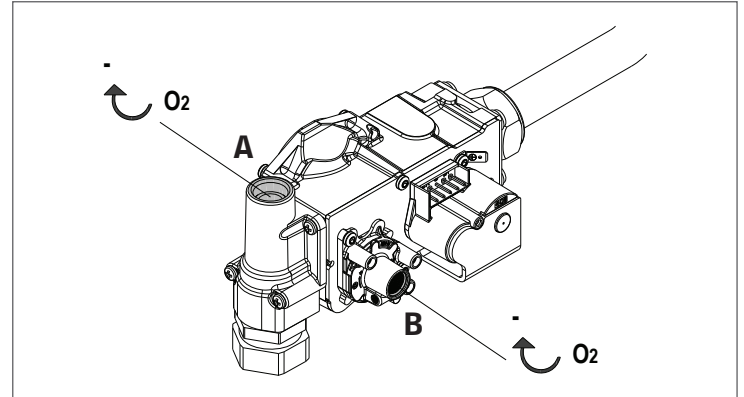

Fig. 21 O₂ Adjustment

Verify that the value of O₂ is stable and within the range indicated in the following table (be careful to make small changes and confirm that the value is stable before making additional adjustment).

Press "Reset" and the boiler return to the "stand by" mode. Repeat above process for all heat exchangers.

Array Combustion Values		
Gas Type	Max. Fire (O ₂ %)	Min. Fire (O ₂ %)
Natural Gas	4.2 – 5.8	4.2 – 5.8
LP Gas	5.0 – 5.6	5.0 – 5.6

4.16 Combustion gas exhaust

For flue gas exhaust and the intake of combustion air, it is essential to use only specific approved pipes for condensing boilers and ensure that they are correctly connected, as shown in the instructions supplied by the vent manufacturer.

⚠ WARNING: Do not connect this appliance's flue gas exhaust pipes with those of other appliances, unless this is specifically authorized by the manufacturer. Failure to comply with this precaution may cause a build-up of carbon monoxide in the room where the appliance is installed causing substantial property damage, severe personal injury or death.

⚠ NOTE: For further information on flue gas exhaust pipes for the Array AR SE series connected in a cascaded system, see section "8.2 Multiple Boiler Cascade Installation and Start-Up" page 37.

⚠ WARNING: Ensure that Intake combustion air is not contaminated by:

- waxes/chlorinated detergents
- chemical products based on swimming pool chlorine
- calcium chloride
- sodium chloride used to soften tap water
- refrigerant leaks
- paint or varnish removers
- chloridric acid/muriatic acid
- cements and glues

- anti-static softeners used in dryers
- chloride used for domestic or industrial applications as detergent, whitener or solvent
- adhesives used to glue construction and other similar products.

⚠ To prevent contamination of the boiler, do not install combustion air intake and gas flue exhaust pipes near:

- dry-cleaners/laundry rooms and factories
- swimming pools
- metal processing plants
- beauty parlours
- fridge repair shops
- photo-processing facilities
- body-shops
- plastics manufacturing plants
- furniture workshops and manufacturing plants.

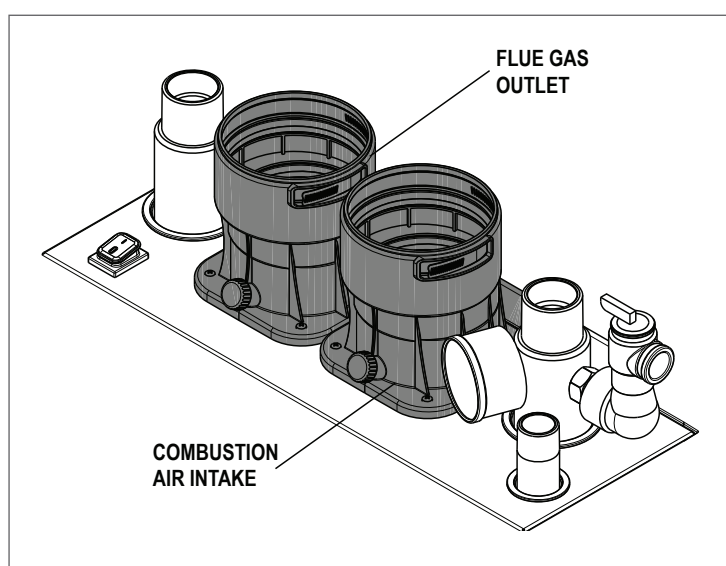

Fig. 22 Flue gas outlet & combustion air intake

DESCRIPTION	Array AR SE	
flue gas outlet	4" (102mm)	∅
combustion air intake	4" (102mm)	∅

⚠ **WARNING:** Read the requirements, instructions and prohibitions detailed below carefully, since non-compliance with them may result in substantial property damage, severe personal injury, death, or the appliance's malfunction.

⚠ **WARNING:** Check that pipes and joints are not damaged.

⚠ **WARNING:** Joint seals must be executed with materials that withstand the condensate's acidity and the temperatures of the appliance's flue gases. They must be approved joint methods as stated by the vent manufacturer's installation instructions for this type of condensing product. Failure to comply may result in substantial property damage, severe personal injury or death.

⚠ **WARNING:** When installing flue pipes, always bear in mind the direction of the flue gases and of possible condensate flows.

⚠ **WARNING:** Inadequate or incorrectly sized flue gas pipes may increase combustion noise, create condensate extraction issues and negatively impact on combustion parameters.

⚠ **WARNING:** Check that pipes are suitably far (minimum 20 po - 500 mm) from flammable liquids.

⚠ **CAUTION:** Make sure that condensation is not built up along the exhaust flue pipe. For this purpose, provide a slope of at least 3 degrees towards the appliance in horizontal sections. In case of cascade application, if the horizontal or vertical section is longer than 13ft (10m) in a cascade vent application, a condensate siphon drain must be provided at the base of the pipe. The siphon discharge must then lead to a drain with an air gap between drain and the condensate trap (see section "4.13 Condensate Drain and Piping" page 21").

⚠ **WARNING:** It is prohibited to block or section the flue gas exhaust pipe or the combustion air intake pipe, if any.

⊖ **WARNING:** It is prohibited to use condensate pipes that are not designed for this application, as the condensates acidity would damage them quickly.

- Adjust the O₂ parameter as explained in next chapter
- Affix the gas type label from the gas conversion kit to the appliance.

4.17 Wiring diagram

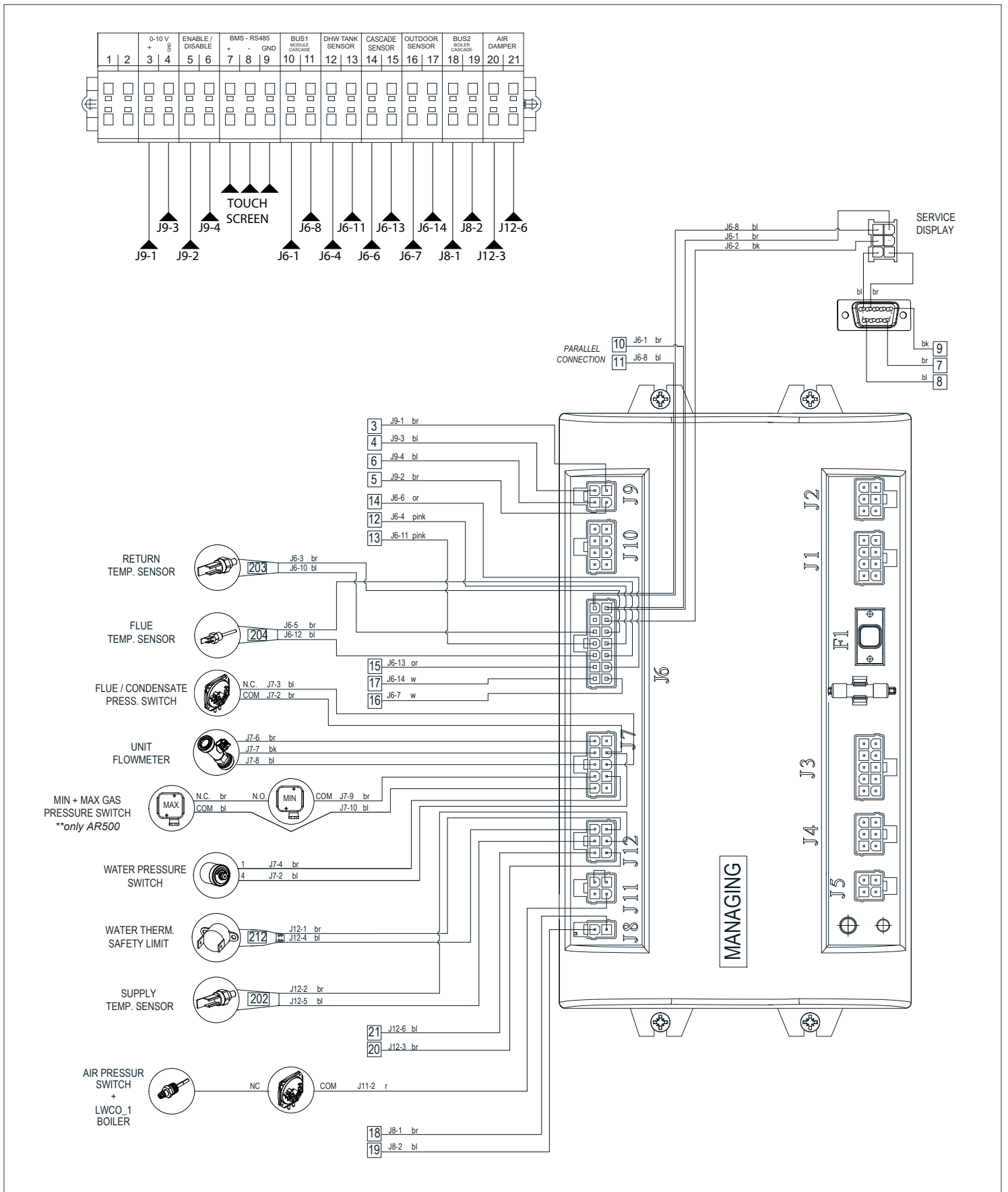

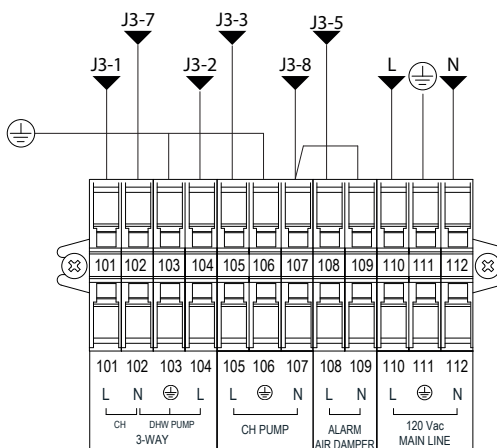
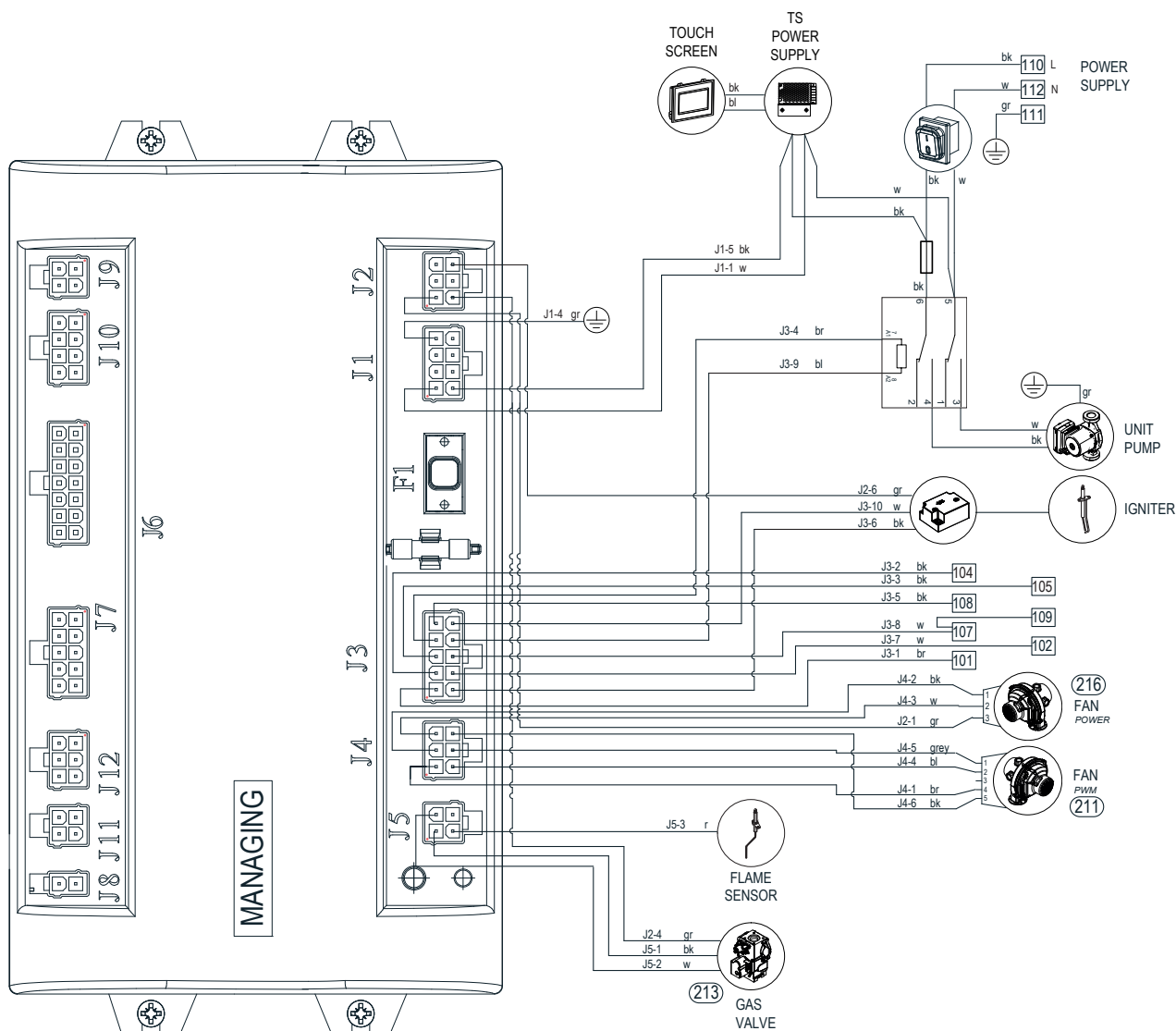

4.18 AC Electrical Power Wiring

External AC power is connected to the unit inside the electrical box, located on the inside of the front doors. Open the front doors and remove the ABS plastic cover as shown in Fig. 23.

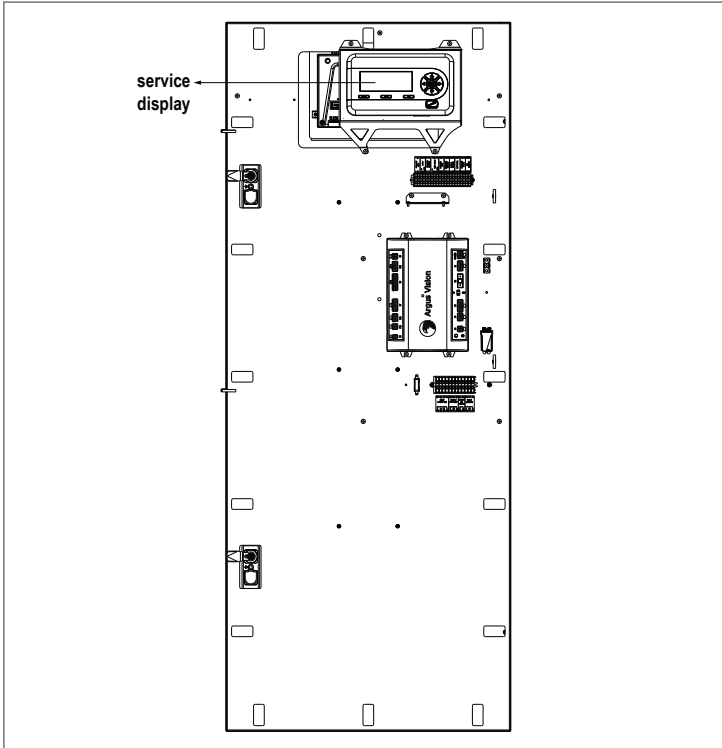

Fig. 23 Front Doors Internal Layout

To power on the unit, put the button shown in Fig. 24 to "I".

NOTE: The '0' position of the switch does not guarantee the absence of voltage in the power cable; the boiler must be disconnected from the external panel.

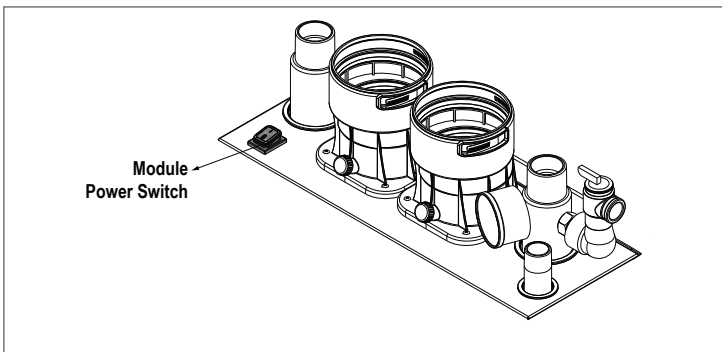

Fig. 24 Module Power Switch

All of the components in the Electrical box are mounted on a DIN rail.

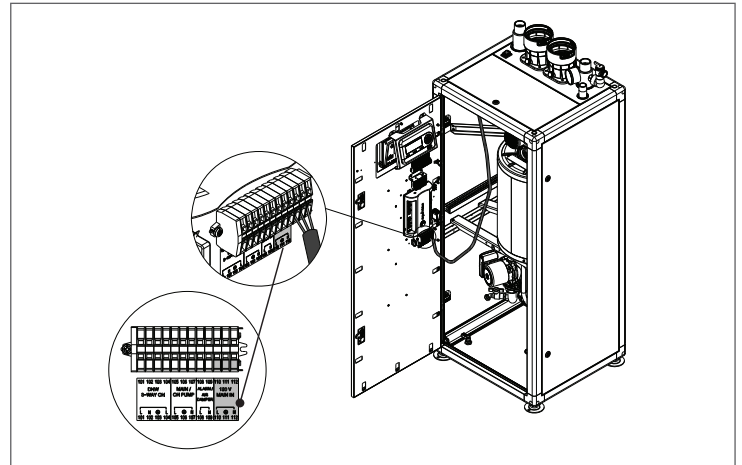

Fig. 25 Front Door Electrical components

NOTE: All electrical conduit and hardware must be installed so that it does not interfere with the removal of any unit covers, inhibit service/maintenance, or prevent access between the unit and walls or another unit.

4.18.1 Electrical Power Requirements

The voltage configuration of **Array AR 399 SE and AR 500 SE** is 120VAC/1PH/60Hz.

Each boiler must be connected to a dedicated electrical circuit.

NO OTHER DEVICES SHOULD BE ON THE SAME ELECTRICAL CIRCUIT AS THE BOILER.

The Main Circuit four-pole switch is accessible on the front door to quickly and safely disconnect electrical service. This breaker does not remove power on the incoming power supply terminals.

The installed boiler must be electrically bonded to ground in accordance with the requirements of the authority having jurisdiction. In the absence of such requirements, the installation shall conform to National Electrical Code (NEC), ANSI/NFPA 70 and/or the Canadian Electrical Code (CEC) Part I, CSA C22.1 Electrical Code.

4.19 Field Control Wiring

Each unit is fully wired from the factory with an internal operating control system. No field control wiring is required for normal operation.

However, the control system used with all **Array** boilers does allow for some additional control and monitoring features. Wiring connections for these features are made on the Input / Output (I/O) terminal strips located behind the removable cover on the inner side of the front door of the unit, as shown in Fig. 26.

NOTE: Any electrical load connected to the terminal strip (external pumps, air damper, alarm) must be powered through a relay, not included in the boiler, to be provided and wired by the installer.

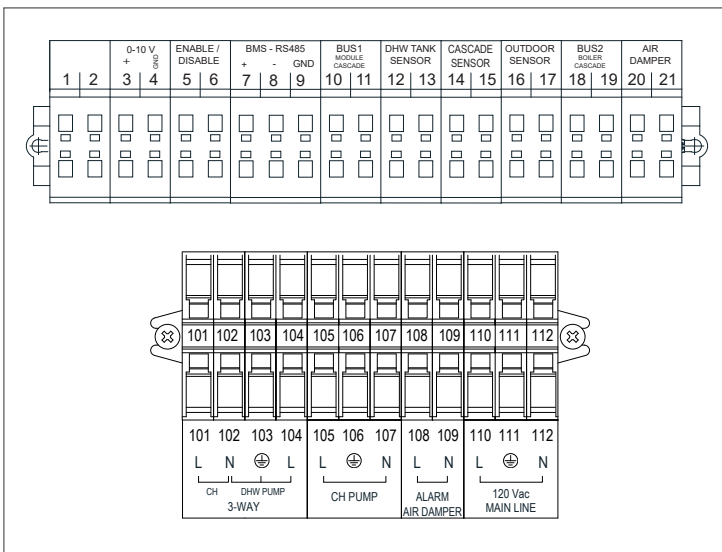

Fig. 26 I/O Terminal Strips

All field wiring is installed from the rear of the panel by routing the wires through one of the openings provided on the sides of the cover panels (see Fig. 27).

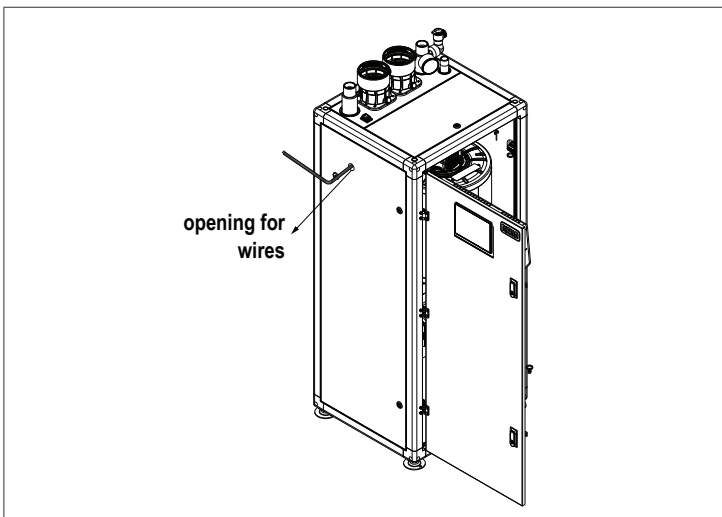

Fig. 27 Opening on the Cover Panel

5 AIR DAMPER

The Air Damper output comes disabled from the factory. The Air Damper is connected to a Triac controlled output that arrived on the terminal strip on 108-109. This output needs a minimum load of approx. 10VA to work correctly and the max load must be limited to 50VA at mains voltage. Connection of an external relay to this output to be able to switch a higher load is only possible when an additional resistor or load is added to make sure the minimum load requirements are met.

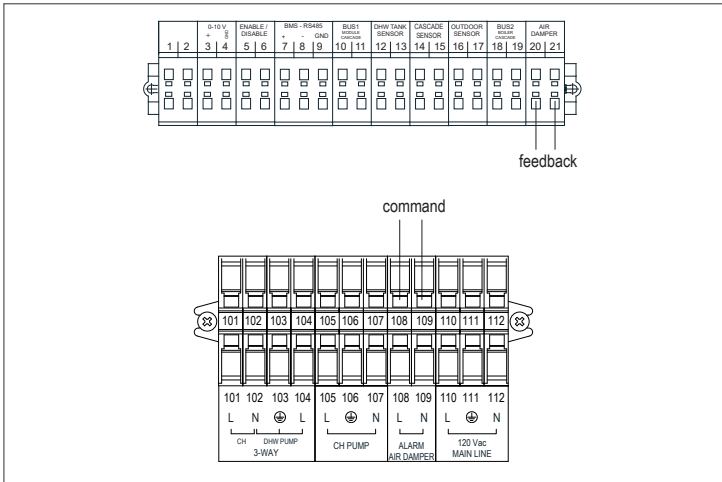

Fig. 28 I/O Terminal Strips

To enable the air damper function, the configuration of the Managing board must be change:

	Default	Air Damper enable
Par. 126 – Prog. Output 2	6	10

⚠ WARNING: For the connection of the devices connected to the terminal block (pumps, circulators and diverting / mixing valves) use interposed relays unless the maximum absorption of all components connected to the board (including the boilers circulator) is less than or equal to 1.5 A. Relay sizing is the responsibility of the installer depending on the type of connected device.

NOTE: To use the airdamper is necessary to configure a cascade.

Set the Par. 127.
Proceed as follows:

- On the home screen of the control panel, press the “Menu” key
- Select “Settings” with the ▲ / ▼ keys and press the ● key
- Select “Boiler Settings” with the ▲ / ▼ keys and press the ● key

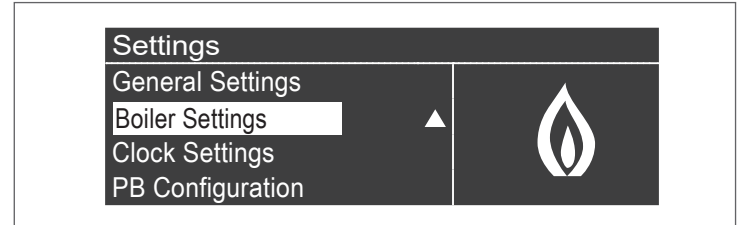

- Enter the password (installer level minimum)
- Select “Boiler Parameters” with the ▲ / ▼ keys and press the ● key

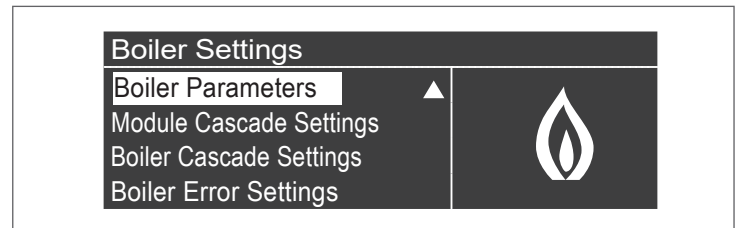

Press the ▼ key, select “(127) Prog. Output 3.” and press the ● key

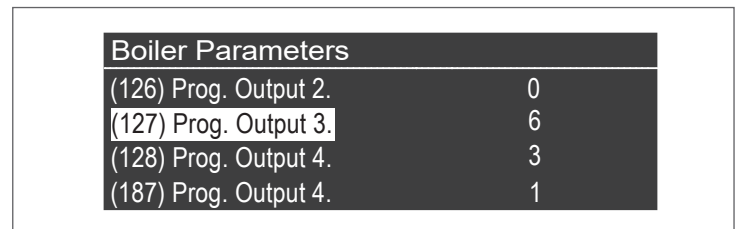

6 COMMISSIONING

6.1 Boiler Startup Procedure

To start the boiler, do the following:

- Open the manual gas shut off valve.
- Turn ON the main power switch.
- Push all Module power switches to ON.
- To help remove the air from the hydraulic circuit, the De-airing function can be started for each module. When activated, the "De-Air" sequence starts at every power ON and consists of a controlled cycling of the pumps OFF and ON that takes 14 minutes, during which no demand will be served. If the water pressure is too low and the water pressure switch is in error, the sequence will be suspended until the pressure switch is ON again. This function can be started through the Service display, switching the parameter (139) Dair_active from No to Yes.
- The Touchscreen Control Panel will switch on. The Splash/Stand-by screen consists of the **RIELLO** logo:



Fig. 29 Touchscreen Control Panel Stand-by screen

By touching the logo, the Module screen will appear:

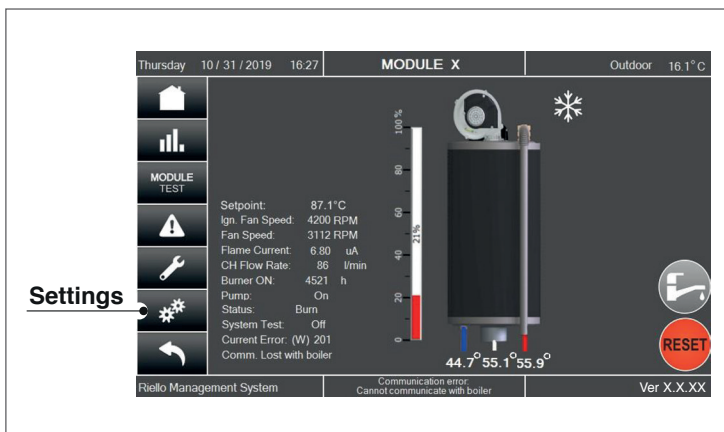

Fig. 30 Module Screen

- Pushing the Settings button, the Settings screen will appear:

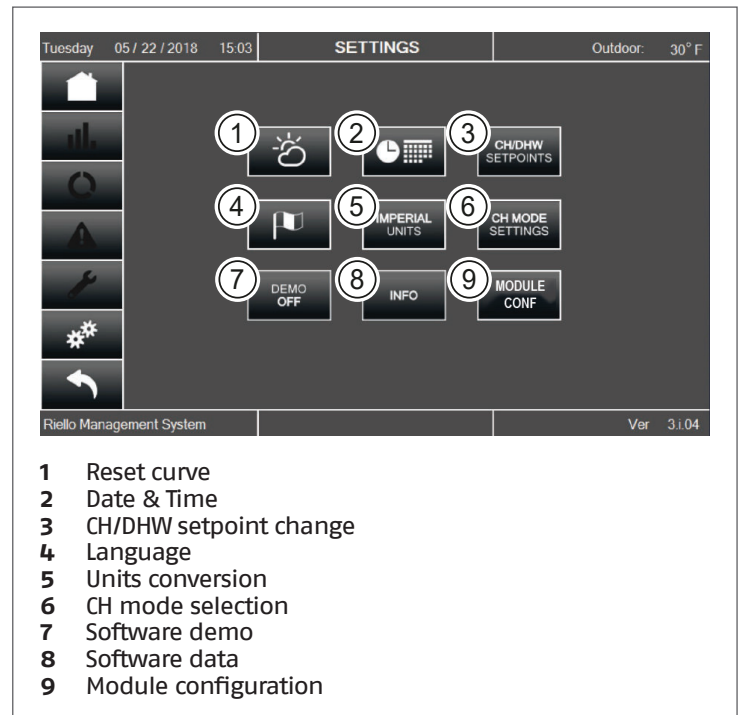

Fig. 31 Settings screen

- Date and Time can be adjusted through the screen below:

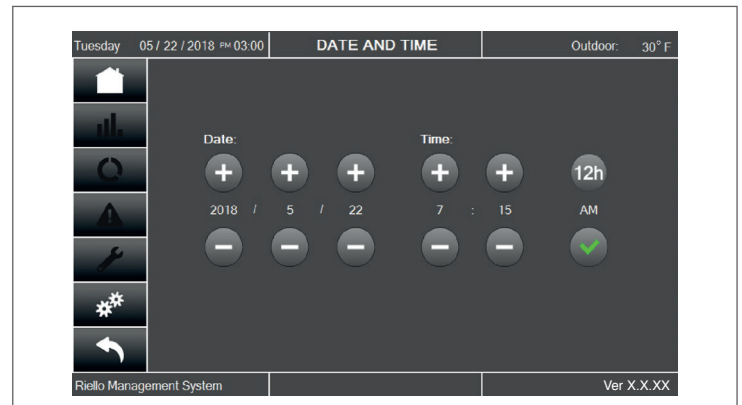

Fig. 32 Date & Time screen

- After the Date&Time setting, CH modes can be selected accessing the CH MODE settings screen below:

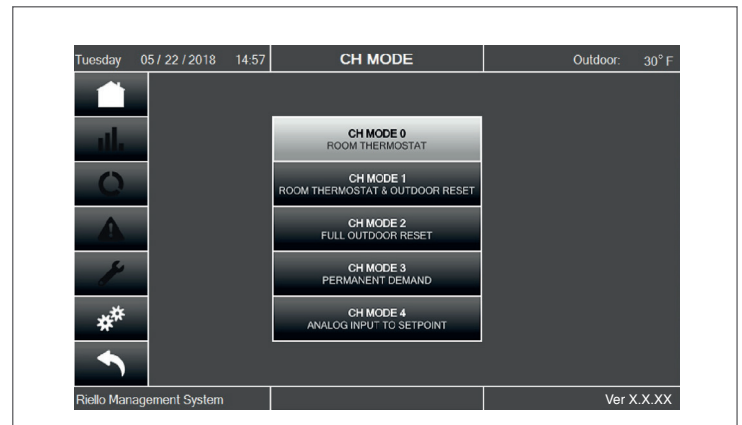

Fig. 33 Mode Screen

Five CH modes are available, but only four are mentioned in the following text:

- **CH Mode 0 - Room Thermostat (Enable/Disable):** when the room thermostat closes, the system switches ON. Temperature Setpoint is manually set on the CH/DHW Setpoints screen (through the Settings screen).

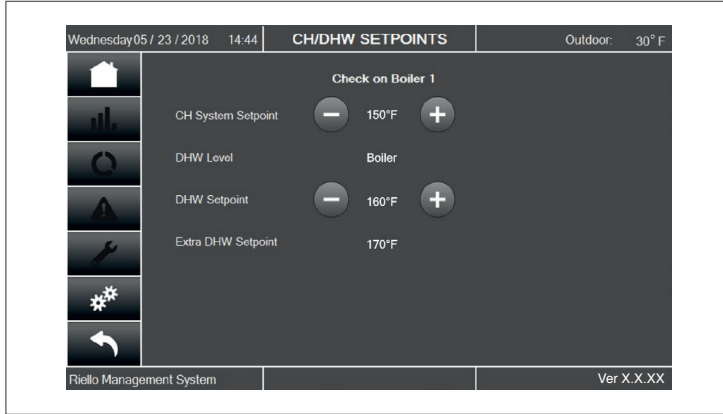

Fig. 34 CH/DHW Setpoints

- **CH Mode 1 - Room Thermostat & Outdoor Reset:** this mode requires an outdoor sensor, in addition to the room thermostat. The system functions similar to CH mode 0, except the Temperature Setpoint is automatically calculated based on the Reset curve. Curve parameters are available on the Reset curve screen (through the Settings screen).

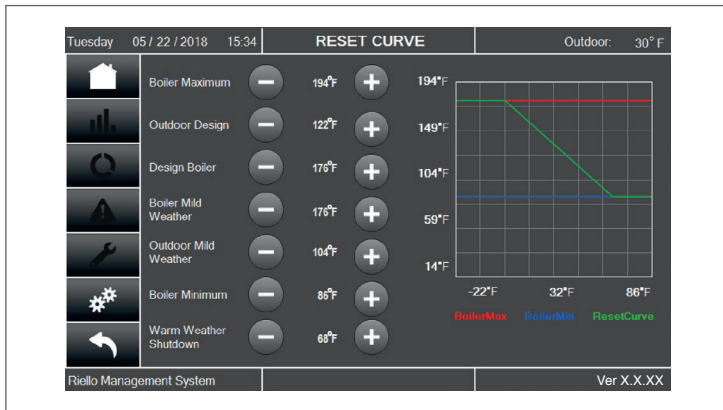

Fig. 35 Reset Curve screen

By adjusting the parameters on the screen, the reset curve will modify its shape and sloper to meet the needs of the specific application.

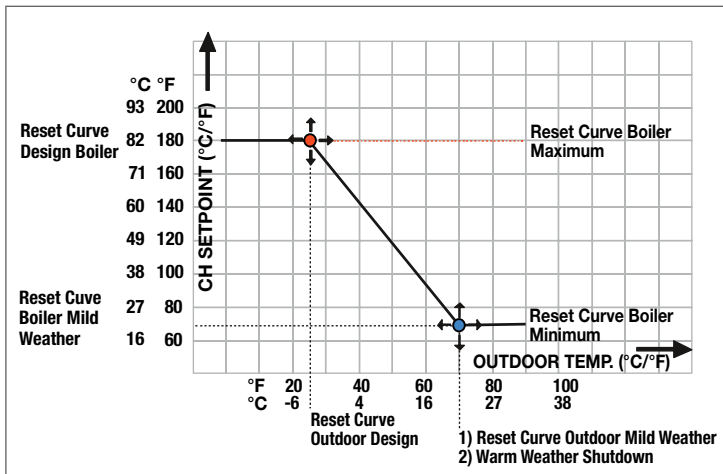

Fig. 36 Reset Curve

- **CH Mode 2 - Full Outdoor Reset:** just an outdoor sensor is required. The Temperature Setpoint is still automatically calculated based on the Reset curve. If a room thermostat is installed, it activates the Night setback function (setpoint reduction during the night) but it does not affect the CH demand.
- **CH Mode 3 - Permanent Demand:** the system works similarly to Mode 0. Supply temperature is kept at the Setpoint level steadily. If a room thermostat is installed, it activates the Night setback function (setpoint reduction during the night) but it does not affect the CH demand. Module pump is always ON.
- **CH Mode 4 - Analog Input to Setpoint:** the Temperature Setpoint is given by an analog signal provided by a remote control such as a Building Management System or a system controller. A heat demand will be generated by an input of 1.5 Volts or higher. Modulation will occur between 2 and 9 Volts.
- Voltage below 1 Volt will shutoff any demand.

NOTE: after selecting CH mode 4, enable it either:

- jumpering "Enable/Disable" pins (#11-12) on Terminal strip or
- accessing the list of parameters through the Service display and move parameter #124 from 1 (default value) to 0.

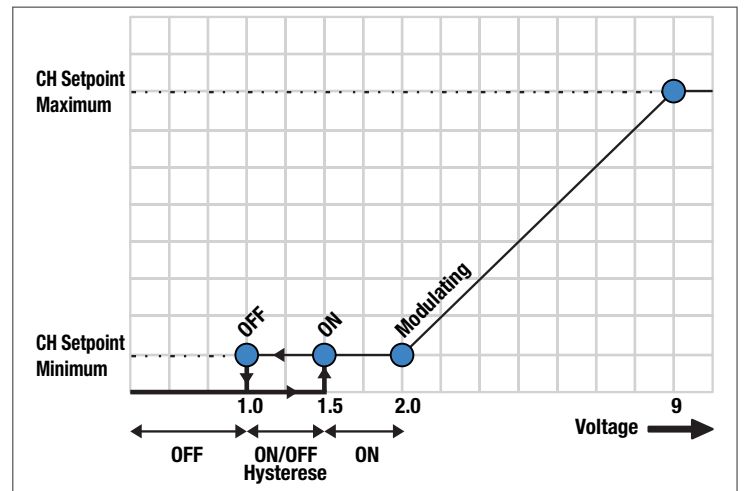

Fig. 37 10VDC Control mode

NOTE: Scale the analogue signal to match the system temperature requirements. scaling the temperature range using the boiler parameters will artificially limit the maximum operating temperature of the boiler.

Domestic Hot Water (DHW) function can be enabled using the parameter 35 on Service display.

Three modes are available:

- **DHW mode 0 - DHW function disabled.**
- **DHW mode 1 - Tank with sensor:** hot water is stored in a tank where the temperature is measured by a sensor. Either a pump or a 3-way valve can be used to switch to DHW mode. When the DHW demand is on, the boiler is PID modulated to achieve the supply temperature made by the DHW store setpoint increased by an adjustable extra temperature. DHW store setpoint is manually set on the CH/DHW Setpoints screen (through the Settings screen).

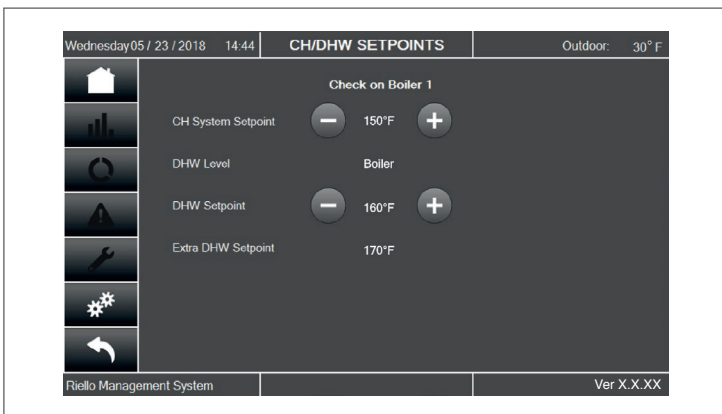

Fig. 38 CH/DHW Setpoints

The parameters that control DHW production are the following:

Par. No.	Description
36	Defines the hysteresis to initiate the domestic hot water demand.
37	Defines the hysteresis to stop the domestic hot water demand.
38	Defines the primary circuit's setpoint increase in degrees compared to the temperature set for the domestic hot water tank.
39	Defines the primary circuit's restart hysteresis in modes 1 and 2 of DHW (valid both for cascade and stand-alone applications).
40	Defines the primary circuit's shut-off hysteresis in modes 1 and 2 of DHW (valid both for cascade and stand-alone applications).
41	Defines the value referred to the Delta T of the tank for maintenance purposes. E.g.: if it is set on 5.4 °F (3 °C), when the tank has a set point lowered of 5.4 °F (3 °C), the boiler turns on at the minimum to allow maintenance until the set point plus hysteresis. If this parameter is equal to parameter 36, this function is inactivated and the boiler starts at the maximum sanitary power.
48	Establishes the DHW storage tank setpoint.

The setpoint value can be set directly, without entering the list of parameters:

- Press MENU and select “Domestic Hot Water” using the ▲ / ▼ buttons.

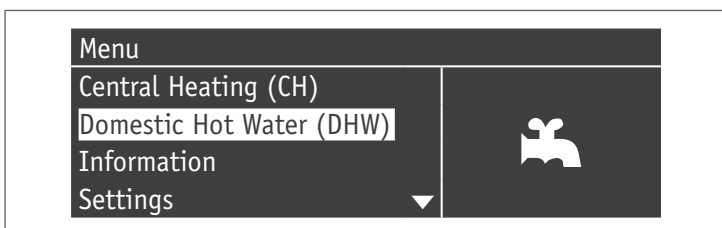

- Press the ● button to confirm.

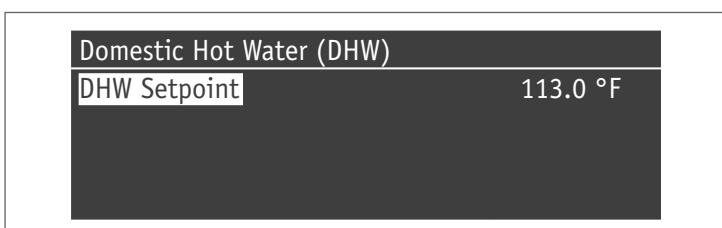

- Use the ► button to highlight the value, and use the ▲ / ▼ buttons to change the selected value. Press the ● button to confirm/save the new settings.

The DHW value can be changed only when the “domestic hot water” function is enabled.

- **DHW mode 2 - Tank with thermostat:** hot water is stored in a tank where the temperature is detected by a thermostat (ON/OFF signal). Either a pump or a 3-way valve can be used to switch to DHW mode. When the DHW demand is on, the boiler is PID modulated to achieve the DHW store setpoint. DHW store setpoint is manually set on the CH/DHW Setpoints screen (through the Settings screen).

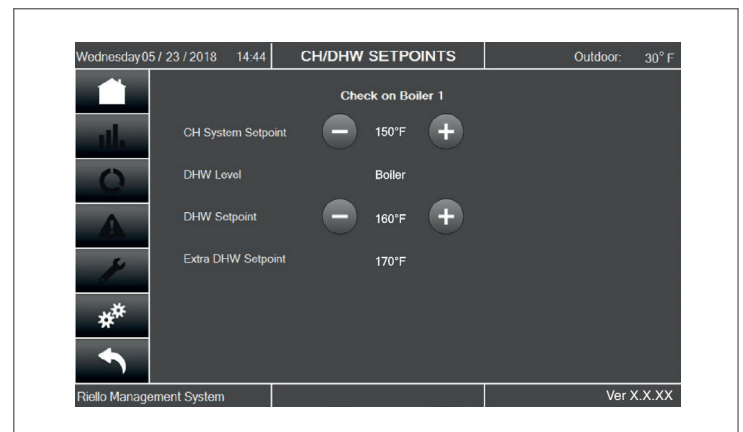

Fig. 39 CH/DHW Setpoints

Temperature summary picture of the DHW tank is available on the DHW screen, accessible through the Tap (faucet) button on the Module screen.

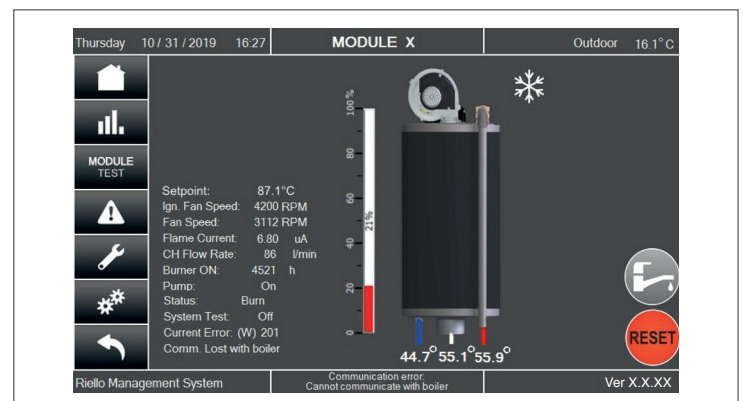

Fig. 40 Module screen

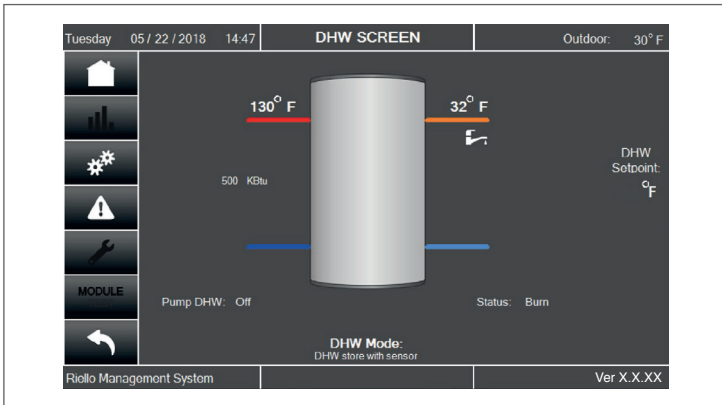

Fig. 41 DHW Screen

The parameters that control DHW production are the following:

Par. No.	Description
38*	Defines the primary circuit's setpoint increase in degrees compared to the temperature set for the domestic hot water tank.
39	Defines the primary circuit's restart hysteresis in modes 1 and 2 of DHW (valid both for cascade and stand-alone applications).
40	Defines the primary circuit's shut-off hysteresis in modes 1 and 2 of DHW (valid both for cascade and stand-alone applications).
48	Establishes the DHW storage tank setpoint.

(*) Parameter 38 is active on such mode even if the indirect tank sensor is not installed and it influences the supply temperature of the boiler.

It can be used to limit the difference between the actual supply and set temperature on the indirect tank sensor so that the system efficiency is maximized.

Also in this case, the setpoint value can be set directly, without entering the parameters list, by accessing the "Domestic Hot Water" menu, as mentioned earlier for mode 1.

Priority setting

Parameter 42 sets the priorities between the DHW and CH circuit. Four modes are available:

- 0 **Time:** timed priority between the two circuits. In the event of a simultaneous demand, initially the domestic hot water circuit is made to operate for a number of minutes equal to the value assigned on parameter 43. At the end of this time period, the CH circuit is operated (also for the same amount of time) and so on until demand for one or the other circuit is satisfied
- 1 **Off:** priority is to the heating circuit
- 2 **On:** priority is to the DHW circuit
- 3 **Parallel:** simultaneous operation of both circuits provided that the delivery temperature requested by the DHW circuit is lower than or equal to the setpoint requested by the heating circuit. When the temperature requested by the DHW circuit exceeds the heating setpoint, the circulation pump of the heating is turned off and priority is switched to the DHW.

Anti-Legionella function

When the production of domestic hot water is activated (Par. 35=1), using parameters 107 and 108 it is possible to carry out weekly scheduling of the "Anti-legionella" function.

Parameter 107 sets the day of the week in which the activity is performed, while parameter 108 sets the time.

At the planned time, the boiler generates a call for the DHW indirect storage tank with a pre-set setpoint of 140 °F (60 °C) (not adjustable). After reaching 140 °F (60 °C), the temperature is maintained for 30 minutes, during which the system checks that the sensor's temperature does not fall below 134.6 °F (57 °C). At the end of this time interval, the Anti-Legionella function stops and standard operation of the boiler is resumed.

Operation in "Anti-Legionella" mode has priority over other demands independently from the setting of the parameter 42.

Par. No.	Description
107	Sets the weekday on which the anti-Legionella procedure is carried out.
108	Sets the time of the day during which the anti-Legionella procedure is carried out.

7 OPERATION

7.1 Introduction

The information in this Chapter provides a guide to the operation of the **Array AR SE** Boiler using the Control Panel mounted on the front of the unit. It is imperative that the initial startup of this unit be performed by factory trained personnel. Operation prior to initial startup by factory trained personnel may void the equipment warranty. In addition, the following **WARNINGS** and **CAUTIONS** must be observed at all times.

⚠ WARNING: Electrical voltages in this system include 230, 120 volts AC and 24 volts DC. It must be serviced only by factory certified service technicians.

⚠ WARNING: Do not attempt to dry fire the unit. Starting the unit without a full water level can seriously damage the unit and may result in injury to personnel or property damage. This situation will void any warranty.

⚠ CAUTION: All of the installation procedures in "Installation" starting on page 16 must be completed before attempting to start the unit.

7.2 Control Panel Description

All **Array AR SE** Series Boilers utilize the Touchscreen Control Panel shown in Fig. 42. This Touchscreen panel contains the basic controls for monitoring the boiler. All other controls, indicators and displays necessary to operate, adjust and troubleshoot the boiler are available on the 905PB inner display.

Additional information on these items is provided in the individual operating procedures and menu descriptions provided in this Chapter.

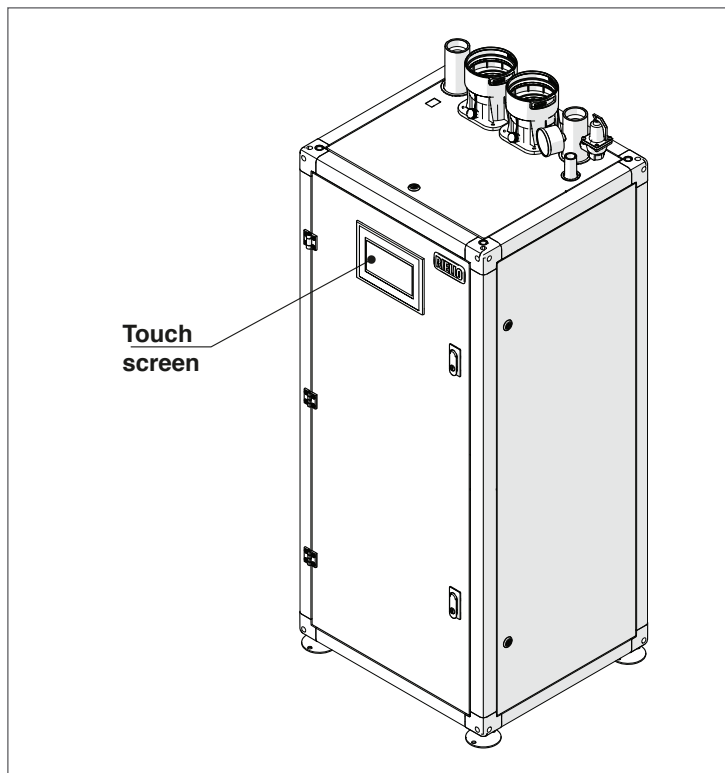

Fig. 42 Touchscreen Control Panel

7.3 Touchscreen Control Panel Menu

The Touchscreen Control Panel incorporates a menu structure which permits the operator to monitor and set up (basic settings only) the unit. The menu structure consists of four major screens and four secondary ones.

7.3.1 Riello Screen



Fig. 43 Riello Screen

The **RIELLO** logo is the entry point of the Control System. By touching it, the system moves to the first operating screen.

7.3.2 Module Screen

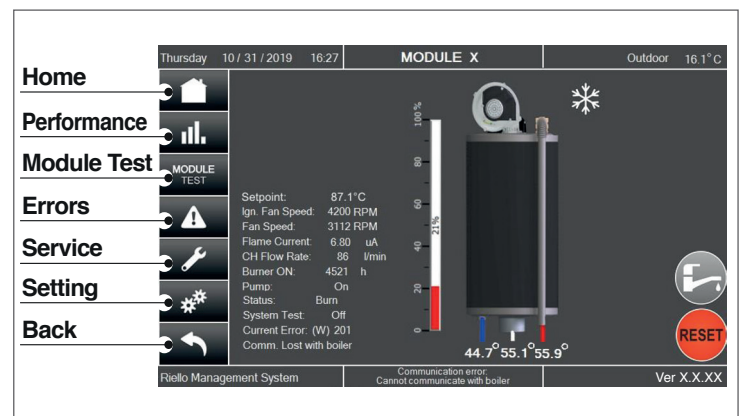

Fig. 44 Module Screen

The module screen shows the current configuration of the plant, consisting of one or more boiler.

Through this screen, the following actions can be done:

- Adjust the temperature setpoint using the "+" and "-" buttons;
- Access the Boiler screen of the desired boiler, by touching the numbered icons on the screen;
- **Home button:** move back to the **RIELLO** screen;
- **Performance button:** move to the Performance screen of the module;
- **Module test:** move to the module test screen;
- **Errors button:** move to the Errors screen;
- **Service button:** move to Service screen;
- **Settings button:** move to Settings screen;
- **Back button:** move to the previous screen.

7.3.3 Performance Screen

The Control system is able to show the last 10 minutes “real time” performance of the plant. The screen shows different information according to the context.

The Performance screen includes the trend of:

- Current Return Temperature
- Current Flue Temperature
- Current Flame

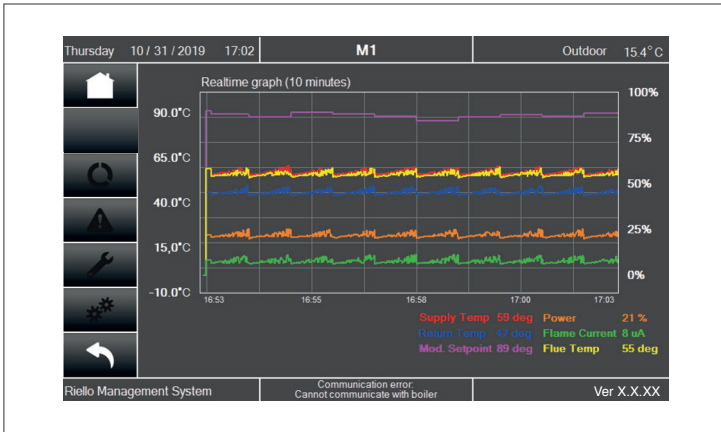

Fig. 45 Performance Screen

The Error screen shows the list of the last 40 errors occurred. The errors are listed in chronological order, under two categories: Blocking errors (auto-reset) and Locking errors (manual reset).

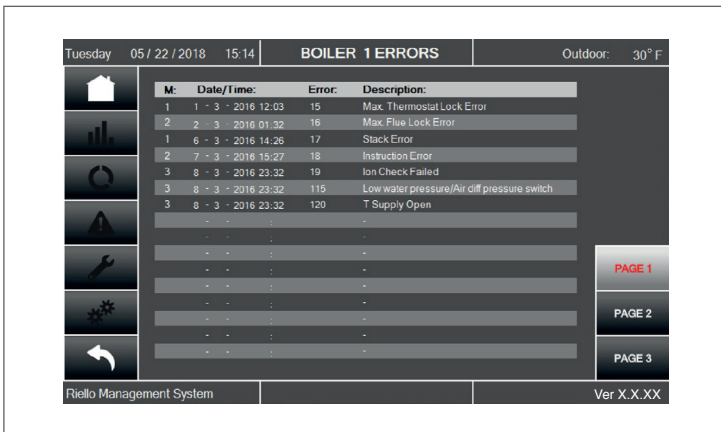

Fig. 46 Error Screen

7.3.4 Service Screen

The Service screen shows the main parameters of the Service Reminder function.

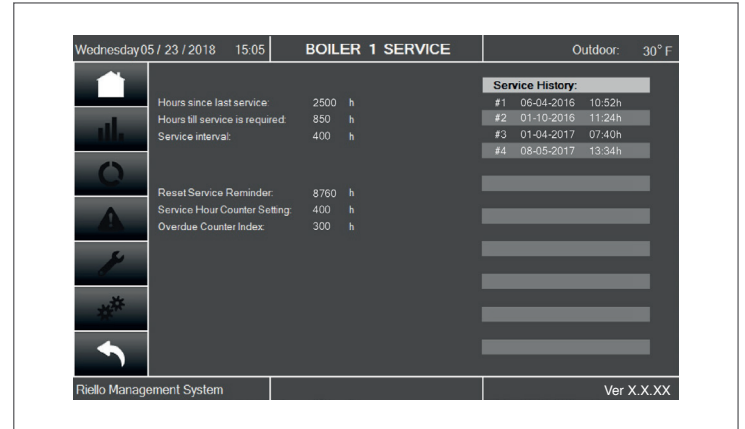

Fig. 47 Service Screen

The **Service Reminder** will remind the owner/user of the appliance to service the appliance at a specified Service_Interval (factory setting).

When service is not done within the specified time, a service reminder will be shown on the screen, alternating with the normal status display.

The **Service Interval** can be set as the number of burn hours or the number of operational (appliance is powered) hours.

This can be done by setting the Service_Hour_Counter (factory) parameter.

When the Service Reminder is active, the time before service is actually done is logged by the 900PB (in hours). This time is called the Service Overdue time. With this log the factory can read back how long service was overdue on the system/appliance which can be useful when handling warranty claims.

A maximum of 15 Service moments can be logged by the 900PB, when the log is full it will overwrite the oldest log entry.

Each time the Service Reminder is being reset, a new service moment is counted and the Service Overdue counter will be stored in the log/history.

7.3.5 Test Screen

This screen is designed to support the installer and service activities. When pushing the Module Test button on Module screen, a new set of buttons appears on the left side of the screen.

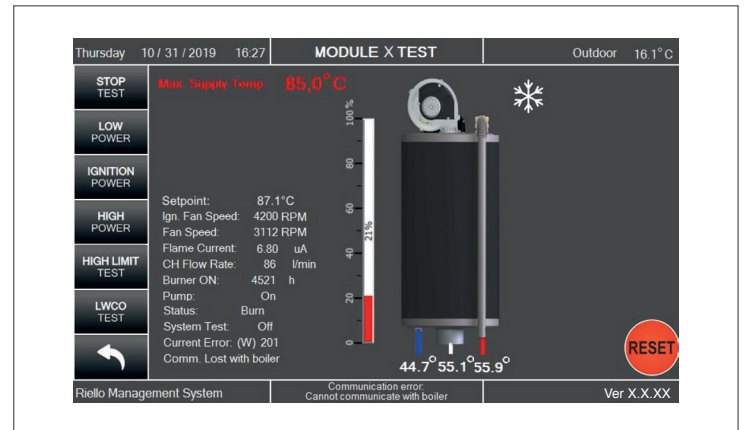

Fig. 48 Test Screen

Setup, adjustments and checks of combustion parameters can be done using the Low Power, Ignition Power and High Power buttons.

In addition, the High Limit button allows the inspector to carry out the high limit temperature switch functionality test.

7.3.6 Cascade Screen

In case of Cascade System, the following screen is displayed.

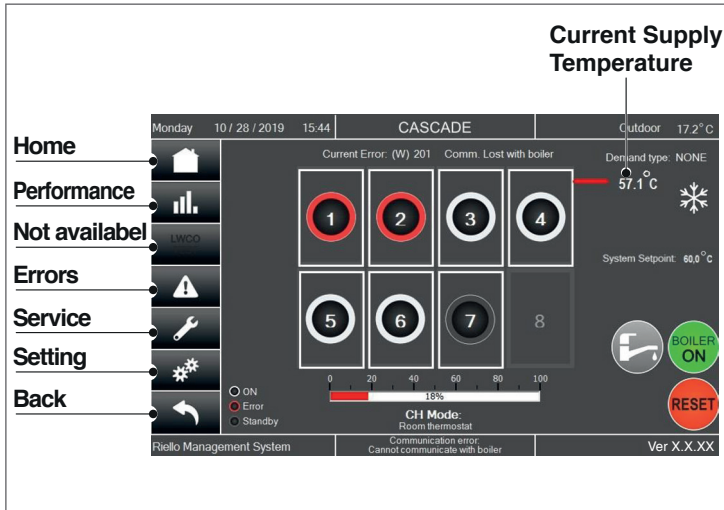

Fig. 49 Cascade Screen

The Cascade screen shows the current configuration of the plant, consisting of one or more cascaded boilers.

Through this screen, the following actions can be done:

- Adjust the temperature setpoint using the "+" and "-" buttons;
- Access the Boiler screen of the desired boiler, by touching the numbered icons on the screen;
- **Home button:** move back to the **RIELLO** screen;
- **Performance button:** move to the Performance screen of the cascade;
- **Errors button:** move to the Errors screen;
- **Service button:** move to Service screen;
- **Settings button:** move to Settings screen;
- **Back button:** move to the previous screen.

7.3.7 Module Screen

Through this screen, the following actions can be performed:

- See the current value of many parameters: water supply & return temperature, flue temperature, water flowrate, fan speed, flame rod ionization current, burner and pump status, any error status or service required;

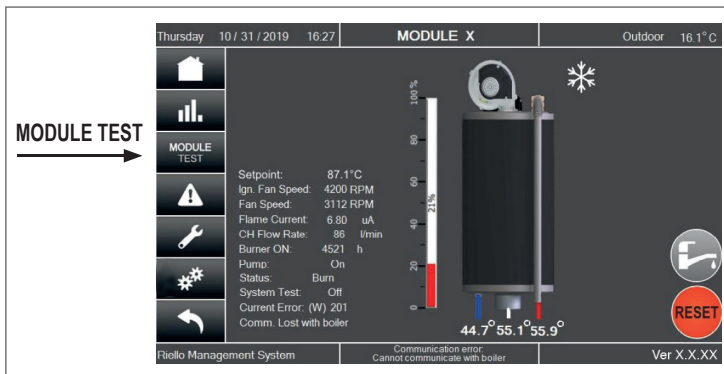

Fig. 50 Module Screen

Use the side buttons to perform the actions listed below:

- **Home button:** move back to the **RIELLO** screen;
- **Performance button:** move to the Performance screen of the module;
- **Errors button:** move to the Errors screen;
- **Service button:** move to Service screen;
- **MODULE TEST button:** move to the Module test screen;
- **Reset button:** clear any Locking error relevant to the module;
- **Back button:** move to the previous screen.

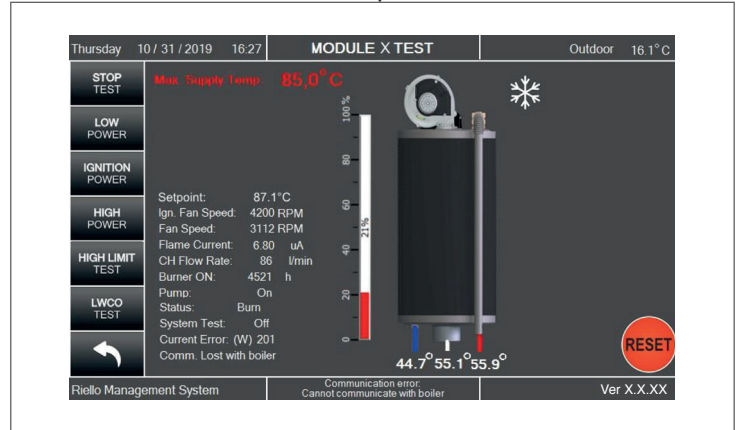

Fig. 51 Module Screen

IMPORTANT: When resetting a Locking error of the Managing module, the whole boiler will be switched OFF and then restarted.

7.3.8 Performance Screen

The Control system is able to show the last 10 minutes "real time" performance of the plant. The screen shows different information according to the context.

The Cascade Performance screen includes the trend of:

- Current power input;
- Targeted temperature setpoint;
- Current supply temperature.

The Module Performance screen includes the trend of:

- Current power input;
- Targeted temperature setpoint;
- Current supply temperature;
- Current Return Temperature;
- Current Flue Temperature;
- Current flame.

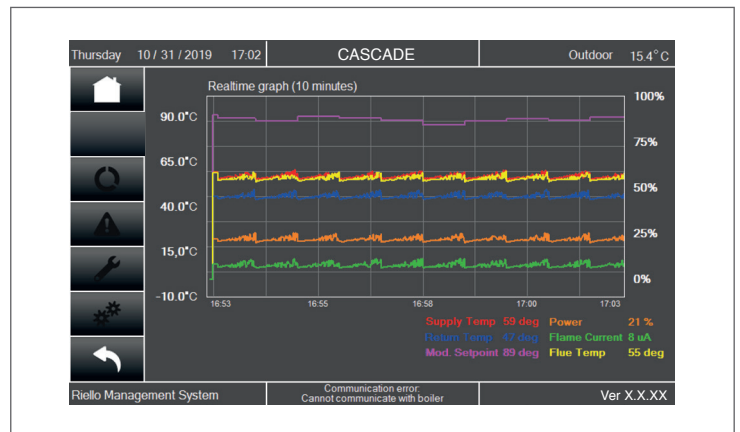

Fig. 52 Performance Screen

7.3.9 Error Screen

For each boiler, the Error screen shows the list of the last 40 errors occurred on its own modules. The errors are listed in chronological order, under two categories: Blocking errors (auto-reset) and Locking errors (manual reset).

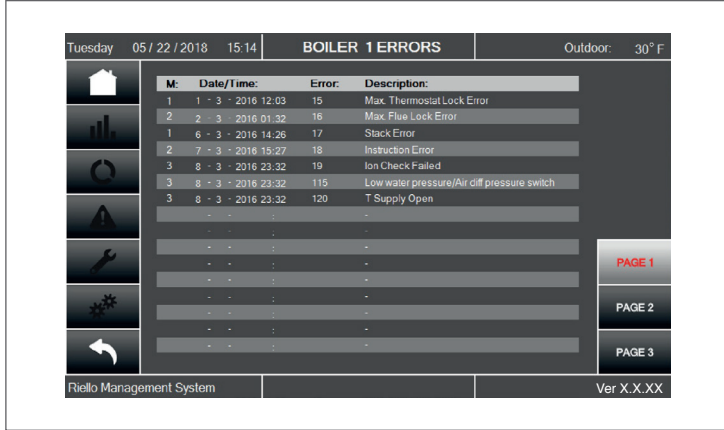

Fig. 53 Error Screen

7.3.10 Service Screen

The Service screen shows the main parameters of the Service Reminder function.

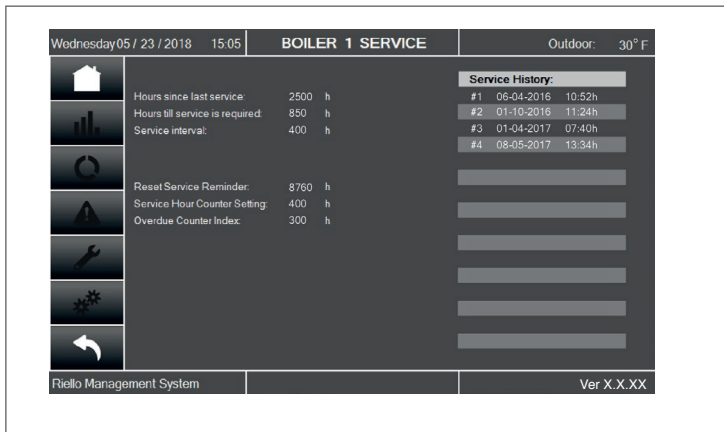

Fig. 54 Service Screen

The **Service Reminder** will remind the owner/user of the appliance to service the appliance at a specified Service_Interval (factory setting).

When service is not done within the specified time, a service reminder will be shown on the screen, alternating with the normal status display.

The **Service Interval** can be set as the number of burn hours or the number of operational (appliance is powered) hours. This can be done by setting the Service_Hour_Counter (factory) parameter.

When the Service Reminder is active, the time before service is actually done is logged by the 900PB (in hours). This time is called the Service Overdue time. With this log the factory can read back how long service was overdue on the system/appliance which can be useful when handling warranty claims.

A maximum of 15 Service moments can be logged by the 900PB, when the log is full it will overwrite the oldest log entry.

Each time the Service Reminder is being reset, a new service moment is counted and the Service Overdue counter will be stored in the log/history.

7.3.11 Module Test Screen

This screen allows to carry out the same operations shown on paragraph "Test Screen" for each cascade module.

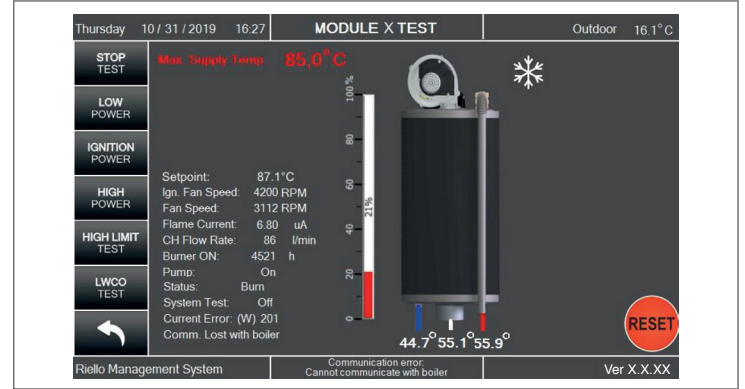

Fig. 55 Module Test Screen

7.3.12 Module Configuration

To correctly set the boiler's power percentage, it is necessary to have selected the correct maximum power.

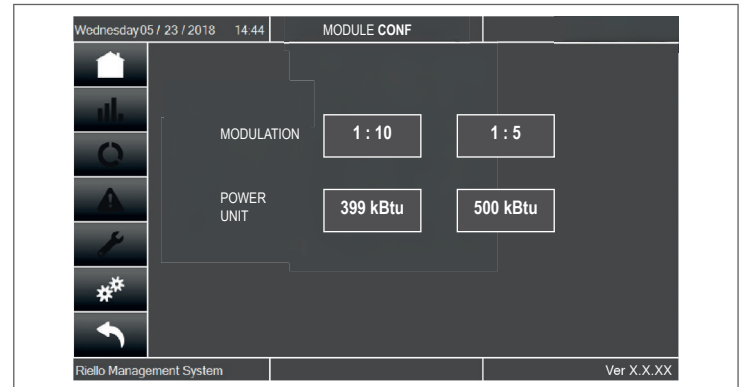

Fig. 56 Module Configuration

8 SYSTEM MANAGEMENT

8.1 Communication between the boilers/modules

Communication between boilers is necessary when using a cascade system to prevent short-cycling and allow equal run-times between units.

The essential steps for configuration are:

- allow the Managing boiler to recognize which and how many depending boilers are present in the system, using the dip-switches
- connect the boiler's with a BUS wire to allow communication between the control units.

8.2 Multiple Boiler Cascade Installation and Start-Up

Fig. 57 shows an example of Array boilers installed in a cascade of three units. The built-in control system is capable of managing up to 8 boilers as a single, coordinated heating system. The logical schematic is:

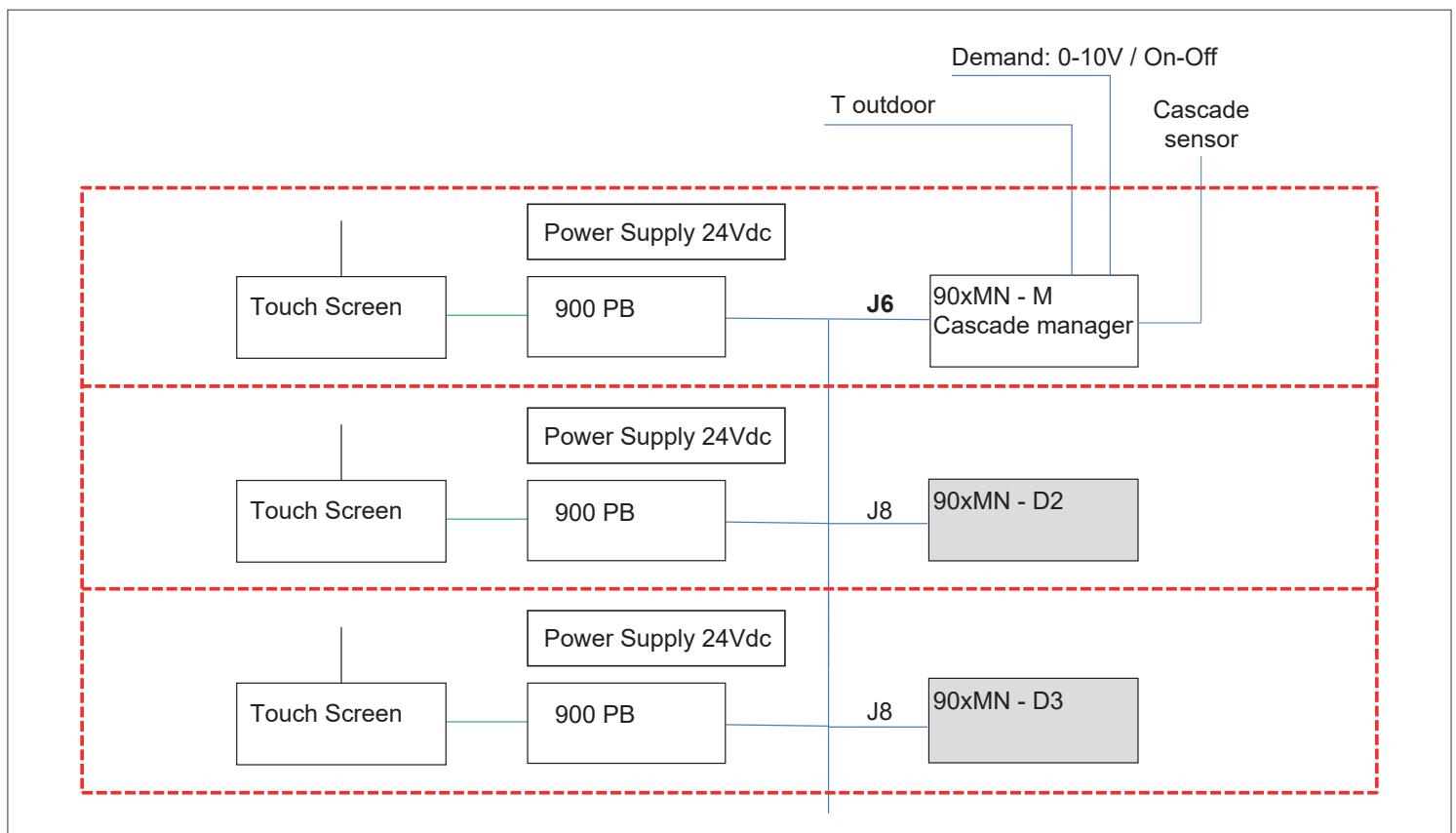
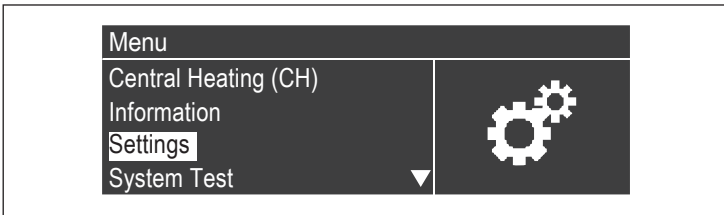

Fig. 57 Module installation scheme

⚠ NOTE: If the managing process stalls, it causes a cascading failure throughout the entire workflow.

8.3 Setting the type of module addressing

Parameter 194 is used to set the type of addressing.
Press the MENU key and select "Settings" with the ▲ / ▼ keys.



Confirm with the ● key and select "Boiler settings" with the ▲ / ▼ keys.

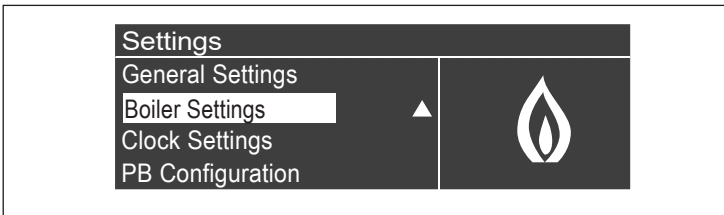

Select "Module Cascade Settings" using keys ▲ / ▼ and press ●.

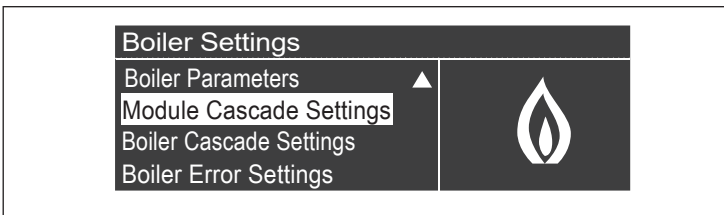

ENABLE PARAMETER

- Select "Dipswitch Config" using keys ▲ / ▼ and press ●
- Use keys ▲ / ▼ to set in "Enabled" and press ● to confirm

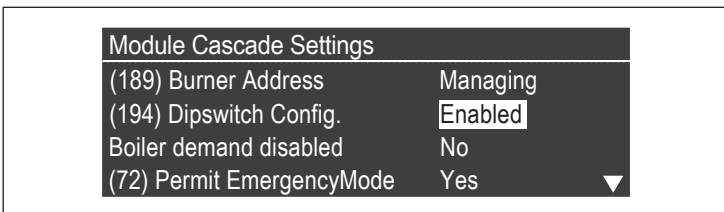

DISABLE PARAMETER

- Select "Dipswitch Config" using keys ▲ / ▼ and press ●
- Use keys ▲ / ▼ to set in "Disabled" and press ● to confirm

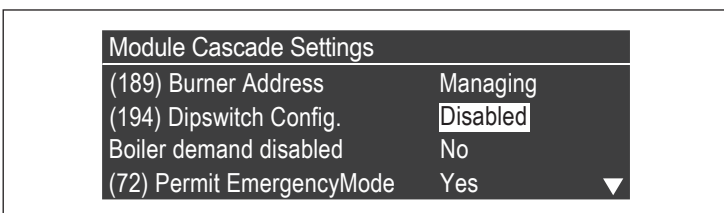

8.4 Module addressing via dip switches

Parameter 194 must be set to "Enabled" before proceeding with the changes (see paragraph "Setting the type of module addressing"). The dip switches of all the modules in the system must be set, and each must be set with an unequivocal sequence. This way the controller of the Managing module will be able to recognise which modules are present in the system.

To access the dip-switches, open the hatch using a flat-bladed screwdriver.

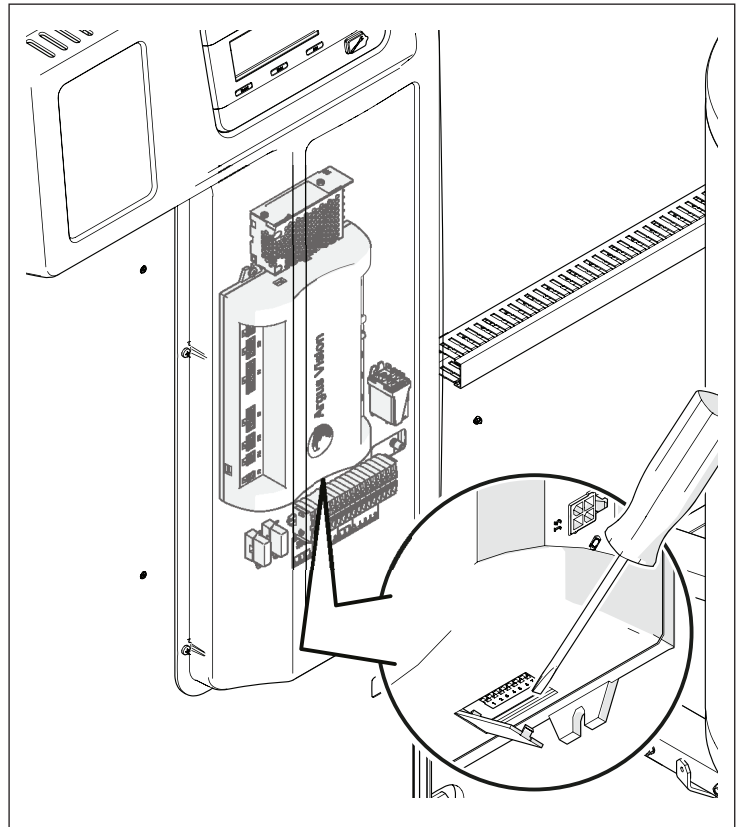

! The setting must be carried out on each module. For configuration of the individual module, refer to the following table.

Key	
	Dip switch ON
	Dip switch OFF
Setting the Dip-switch	Module Configuration
	Stand-alone module (all the dip-switches set to OFF, configuration not used in cascade)
	1st module (Managing)
	2nd module (Dependent)
	3rd module (Dependent)

	4th module (Dependent)
↓	↓
	8th module (Dependent)
	9th module (Dependent)
	10th module (Dependent)

NOTE: If two modules have the same Dip-switch setting, the Managing module will signal a communication error and the cascade will not work correctly.

NOTE: A module will not be recognized if it has the setting of all the Dip-switches set to OFF.

8.5 Address configuration via Display

The board address can also be set from the PB display.

Parameter 194 must be set to "Disabled" before proceeding with the changes (see chap. Setting the type of module addressing).

After entering the setting:

- Select "(189) Module address" using keys ▲ / ▼ and press ●
- Use keys ▲ / ▼ to set the module address (Managing, Dependent 2, Dependent 3, ..., Dependent 15) and press ● to confirm

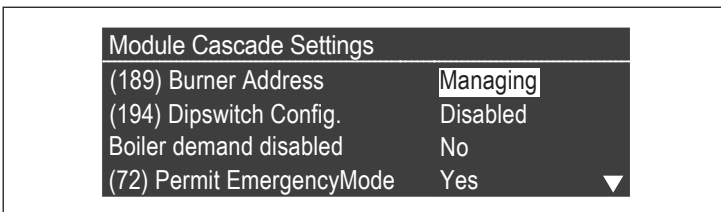

NOTE: The configuration of the physical dip switches is ignored.

8.6 Bus connections

Identify the terminals located below the controller. The bus connections are to be made on the low voltage terminal board (M01).

Module terminal board

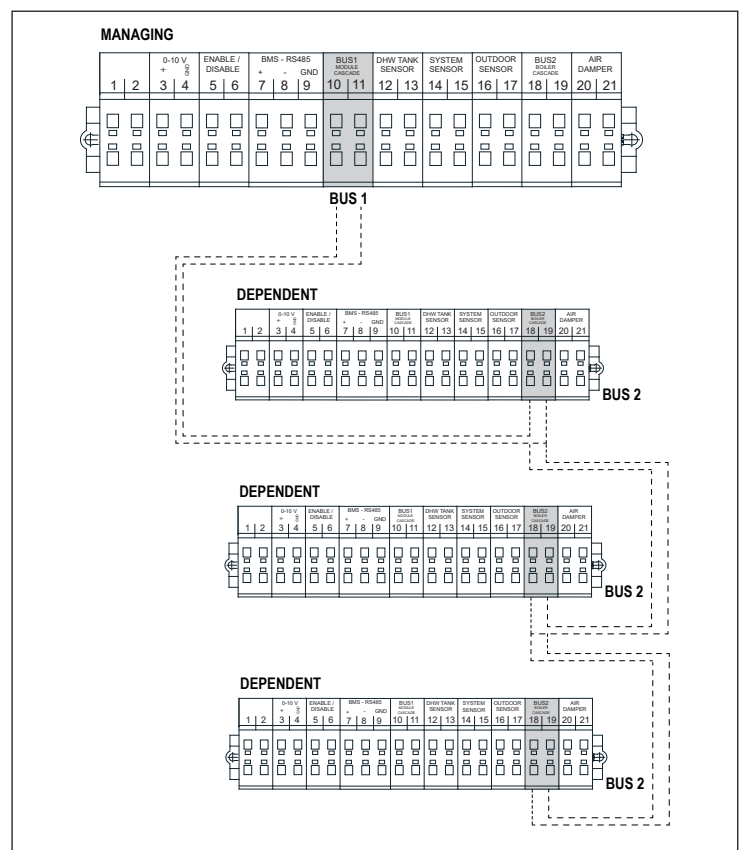
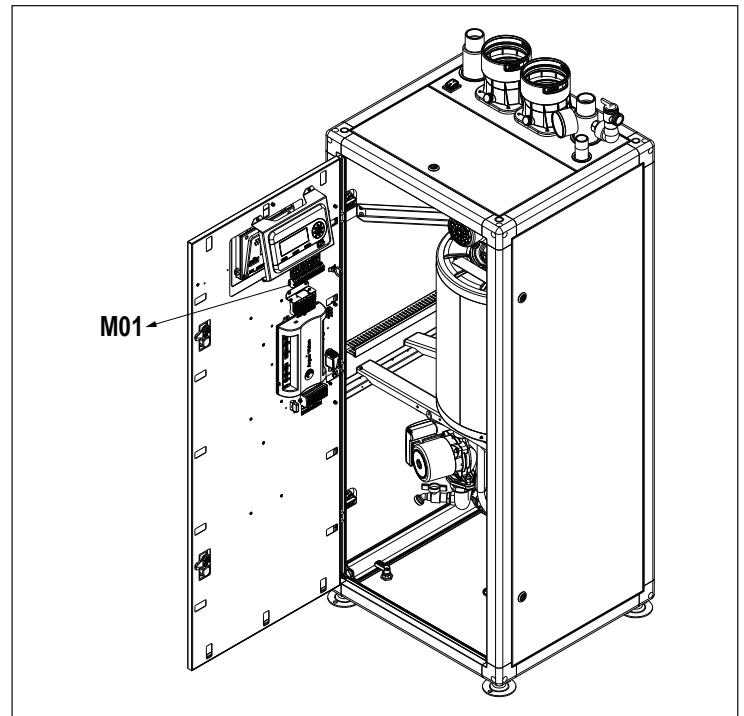

NOTE: The bus connection to the dependent modules must be made in parallel without the closing terminal which would cause a short circuit.

9 CONFIGURATION OF THE MAIN BLOCK DIAGRAMS

⚠ CAUTION: The DHW and heating circuits must be completed with expansion tanks of a suitable capacity and correctly sized pressure relief valves. The discharge of the pressure relief valves and the appliances must be connected in accordance with local code and the authorities having jurisdiction. In general, the pressure relief valve should be routed to a suitable drain, the drain pipe should be within 6 inches from the floor or drain. It is not acceptable for the pressure relief valve to be routed to the outdoors.

⚠ WARNING: The installer is responsible for selecting and installing the system components and must work in full compliance with correct technical regulations and legislation in force.

⚠ CAUTION: Special supply/refill water must be conditioned using suitable treatment systems.

⚠ WARNING: For the connection of the devices connected to the terminal block (pumps, circulators and diverting / mixing valves) use interposed relays unless the maximum absorption of all components connected to the board (including the boilers circulator) is less than or equal to 1.5 A. Relay sizing is the responsibility of the installer depending on the type of connected device.

⊖ WARNING: It is prohibited to operate the boiler without water.

9.1 Configuration of the primary system

The basic cascade configuration consists of at least two boilers, One is assigned "Managing" role and the others are assigned the "Dependent" role.

Cascaded boilers can be seen as the primary circuit of the heating system. This configuration could be ideal for replacing one or more larger boilers in an existing system if system reliability and efficiency is to be increased.

In order for cascade operation to be possible, to the Managing boiler must be connect the Cascade sensor, available in the accessory box (inside the boiler).

The Cascade sensor is required in order to manage the cascade setpoint and is essential for managing the boilers in harmony.

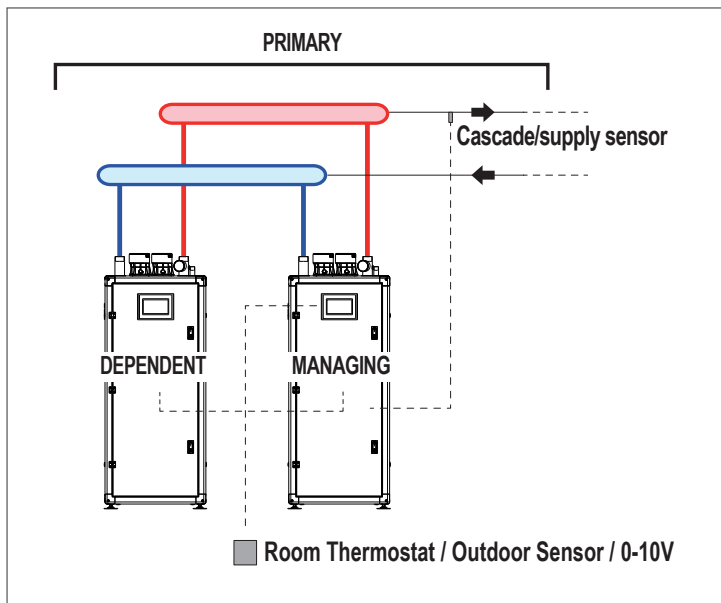

Operation of the primary system can be:

- Mode 0 - With fixed setpoint.
This configuration requires the connection of an ambient thermostat or heat request contact.
- Mode 1 - In climatic mode with variable setpoint based on the outdoor temperature.
This configuration requires the connection of an ambient thermostat or heat request contact and an outdoor temperature sensor, available as an accessory.
- Mode 2 - In climatic mode with intensity controlled by the ambient thermostat/heat request signal and variable setpoint based on the outdoor temperature.
This configuration requires the connection of an ambient thermostat or heat request contact and an outdoor temperature sensor.
- Mode 3 - With fixed supply set point and the boiler controlled by the ambient thermostat/heat request signal.
This configuration requires the connection of an ambient thermostat or heat request contact.
- Mode 4 - With supply setpoint adjustment on the basis of the analog input 0-10V.
This configuration requires an external device (for example, PLC of the central heating system) able to generate this signal connected to the analog input 0-10 V.

The functions described can be set using the "Managing" boiler's control interface. This is described in the manual of the individual thermal modules in the section "6.1 Boiler Startup Procedure" page 29.

The electrical and hydraulic connections of the system are to be completed by selecting the use of the system circulator and two-way valves for each boiler.

9.2 Configuration of the secondary system

Optimal use of the boilers in cascade occurs by placing a hydraulic separator between the primary system (boilers in cascade) and the secondary system. This device allows a different flow rate to be compensated between the primary and secondary systems.

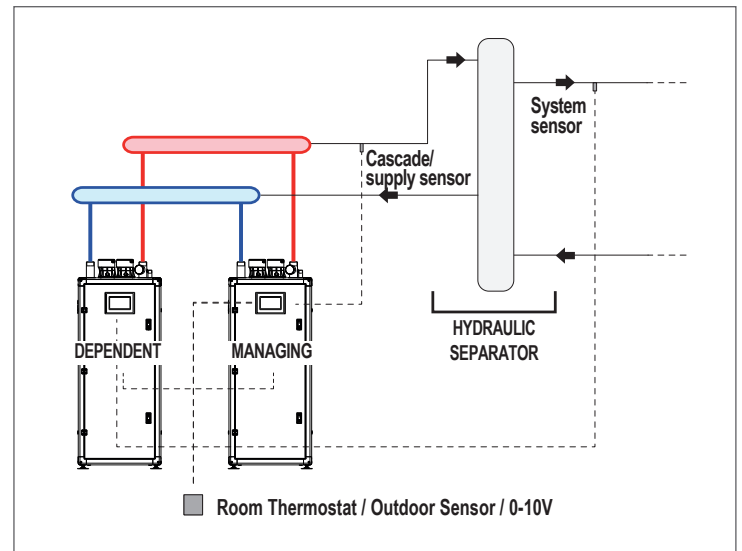

For the sake of simplicity, the hydraulic circuits downstream of the separator can be identified as the secondary system. The basic configuration of the secondary system takes place using a system circulator (CH Pump). This circulator, connected to the boilers in cascade, allows the transfer of the heat energy to a user circuit to be controlled, for example, a direct zone for high temperature heating of a room.

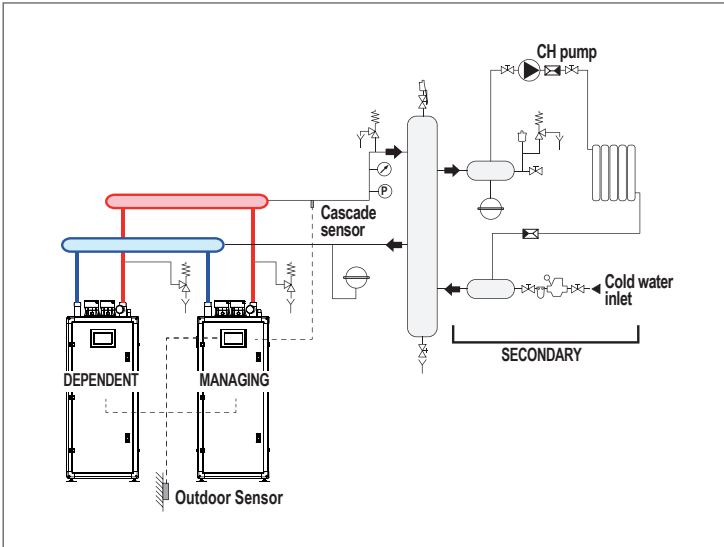

The secondary system can be configured using the following accessories:

- System sensor
This is required in order to manage the setpoint, and therefore the required temperature, downstream of the hydraulic separator. The System is connected to the controller of the first "Dependent" boiler.
- Hot water tank sensor (DHW)
This is required in order to manage the production of DHW in combination with an indirect hot water tank circulator. The indirect hot water tank sensor is connected to the controller of the "Managing" boiler.

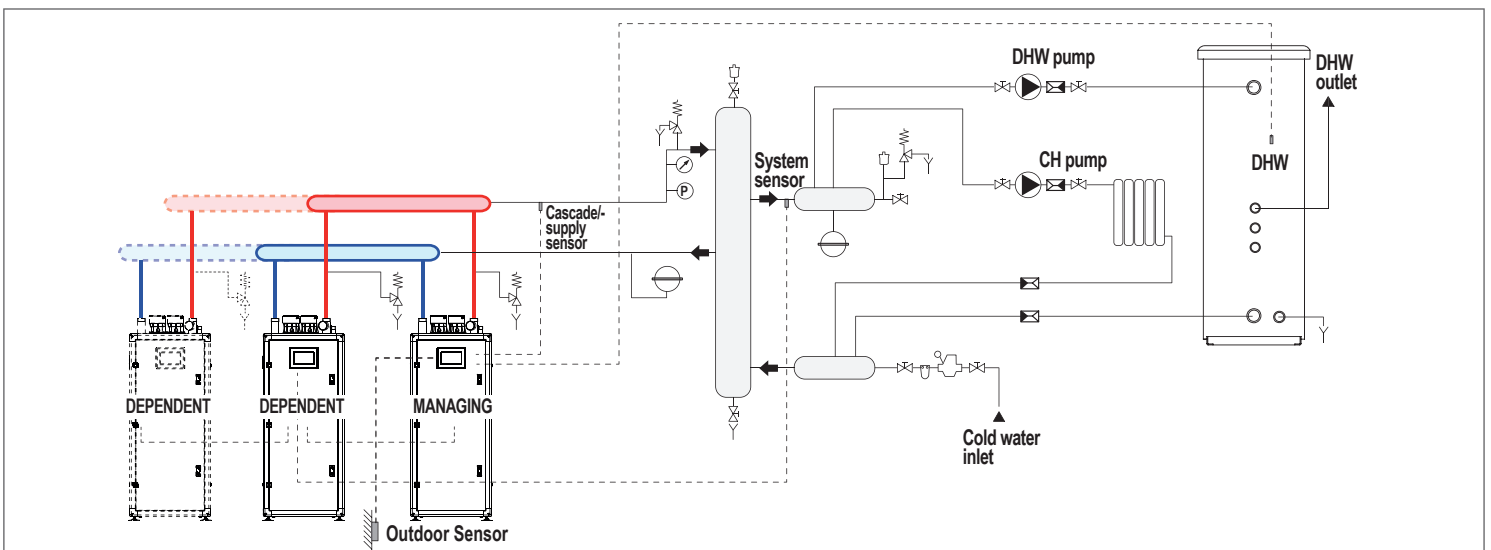

To make the electrical connections, refer to the wiring diagrams of the selected system. For the Bus connection mode, refer to the section "9.3.3 Bus connections" page 43.

9.3 Block diagram

DIAGRAM 1 "Boiler cascade only with cascade/supply sensor"

Boilers with their own circulator, connected in cascade.

Recommended system diagram for new systems or where the water flow rate in the secondary circuit is equal to that in the primary.

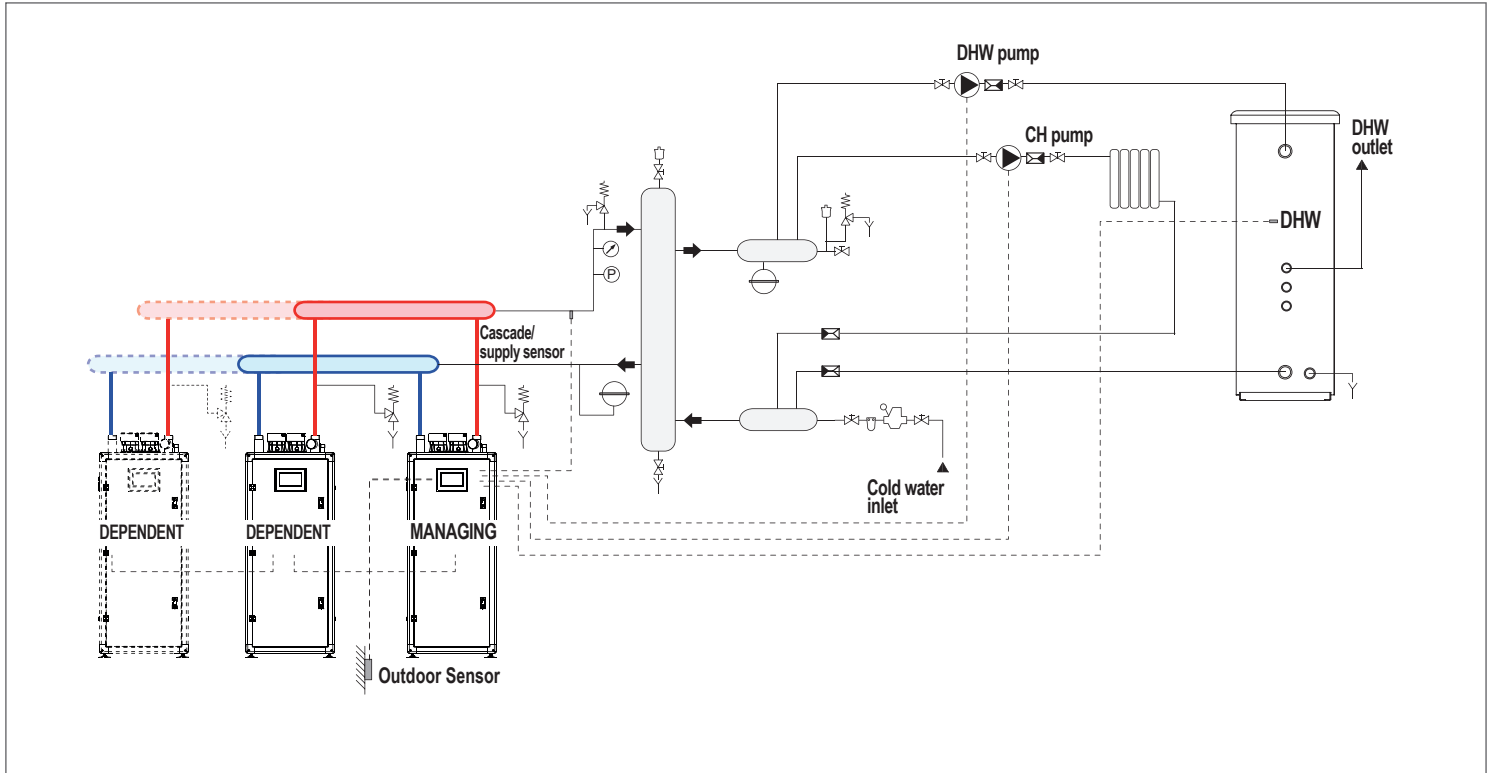

9.3.1 Electrical power connections

MANAGING CONNECTIONS

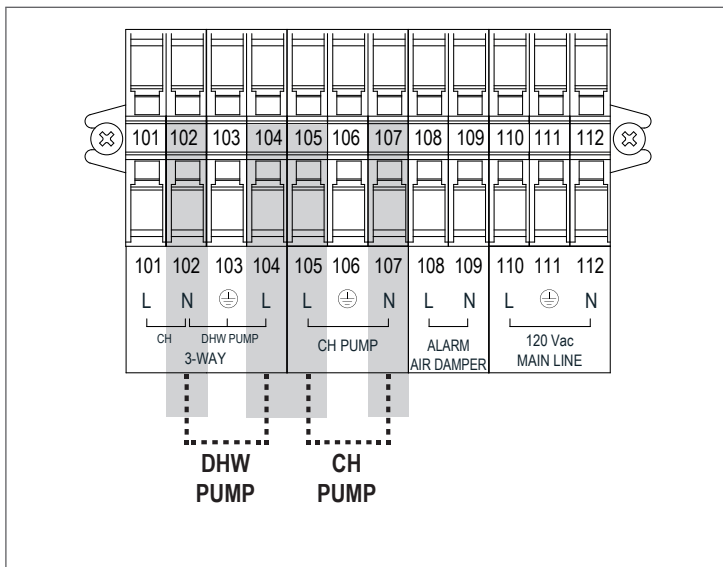

DEPENDENT CONNECTIONS

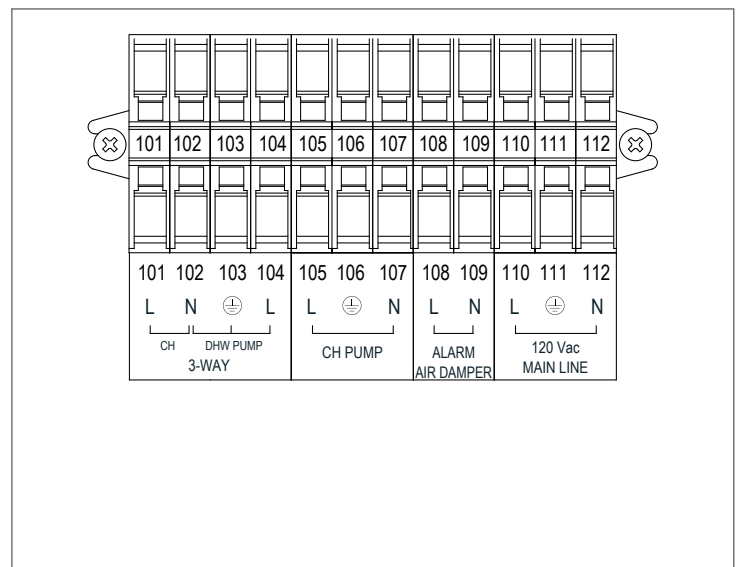

9.3.2 Sensor connections

MANAGING CONNECTIONS

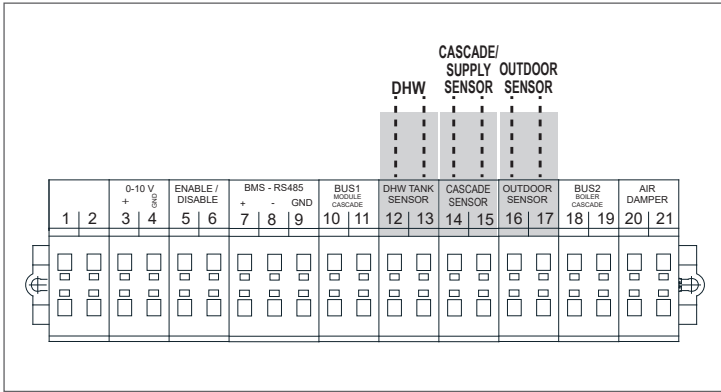

DEPENDENT CONNECTIONS

⚠ NO CONNECTIONS REQUIRED.

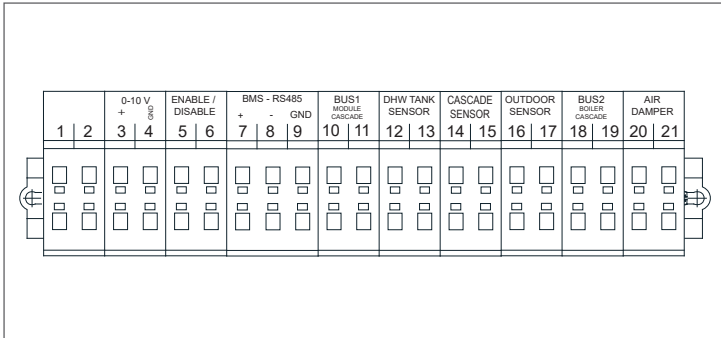

9.3.3 Bus connections

See section "8 System management" page 37 for a detailed description of the connections between the boilers.

MANAGING CONNECTIONS

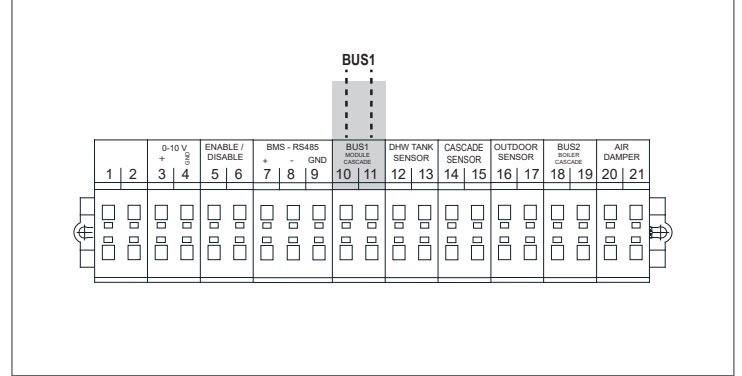

DEPENDENT CONNECTIONS

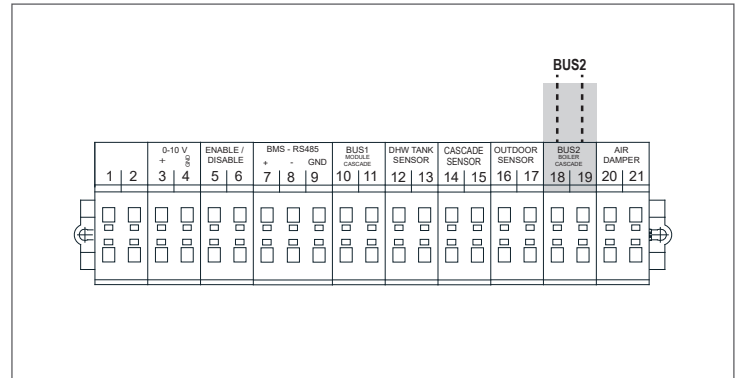

9.3.4 System parameters

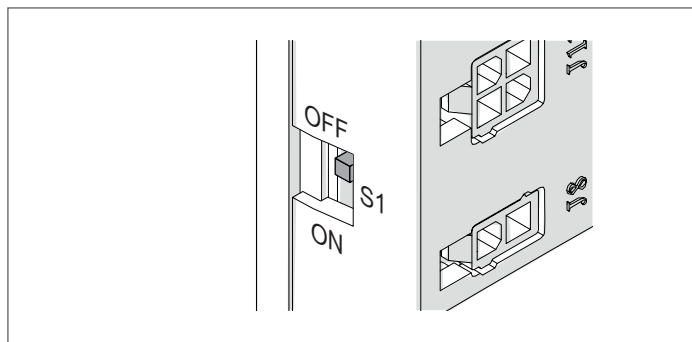

NOTE: See the section “9.5 Setting the main parameters” page 48 for a detailed description on parameter operation

Essential parameters to be configured:

	Description	Default	Managing	Dependent
S1	BUS power supply	Off	(*)	(*)
Dip-switch	Module Address	All 0	1 to ON	2-10 to ON
Par. 189	Burner Address	Stand-alone	Managing	Dependent
Par. 147	Number of Units	8	TOT number of modules	-
Par. 73	Boiler Address	Stand-alone	Stand-alone	(*)
Par. 167	Number of boilers	1	(*)	(*)
Par. 193	DHW for all	No	No	(*)
Par. 184	N. active burner in DHW	16	No. modules needed for DHW	(*)

(*) We do not recommend changing the default settings where not stipulated so as not to alter the operation of the appliance.

Specific parameters to be configured for the block diagram:

	Description	Default	Managing	Dependent
Par. 79	Max. Setp. Offset Down	2°C	(*)	(*)
Par. 80	Max Setp Offset Up	5°C	(*)	(*)
Par. 81	Start Mod. Delay Fact.	60 min	(*)	(*)
Par. 86	PID P	50	(*)	(*)
Par. 87	PID I	500	(*)	(*)
Par. 7	CH Hystereis Up	5	>10	>10

(*) Values recommended for optimum operation.

9.4 Block diagram

DIAGRAM 2 "Boiler cascade with cascade/supply sensor and system sensor"

Recommended system diagram for retrofit systems, when replacing boilers with a high water content or in systems where the water flow rate in the secondary circuit is very different from that in the primary. Circuit with modules with their own pump, connected in cascade. Using the secondary sensor.

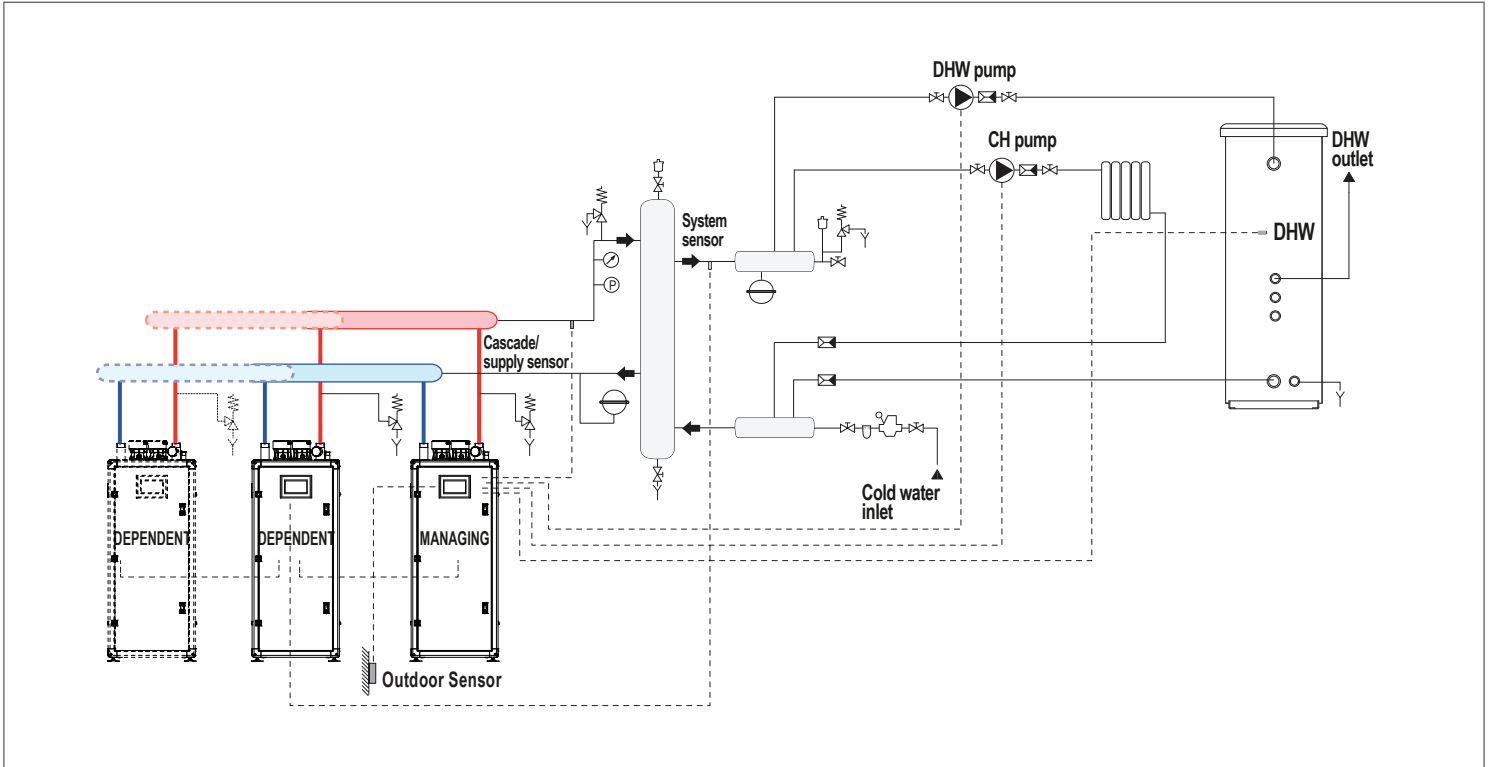

9.4.1 Electrical power connections

MANAGING CONNECTIONS

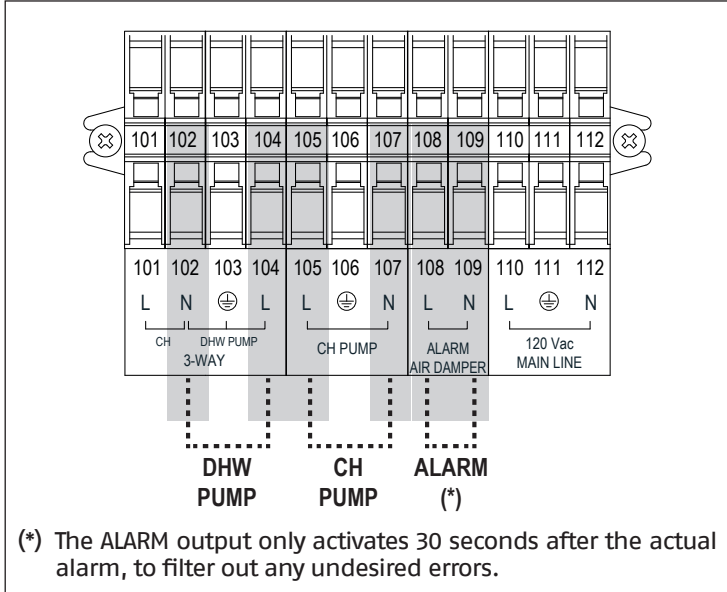

DEPENDENT CONNECTIONS

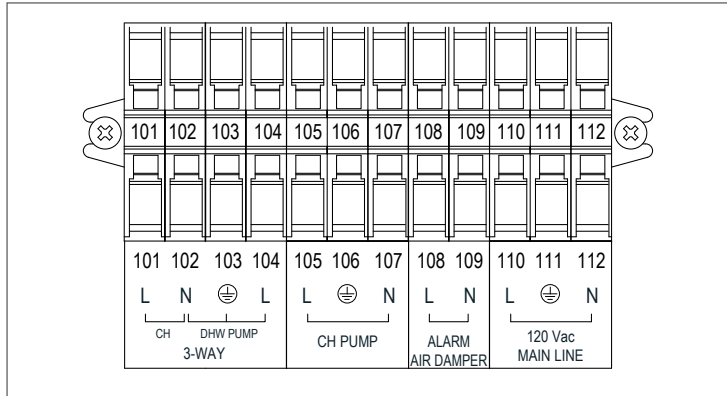

9.4.2 Sensor connections

MANAGING CONNECTIONS

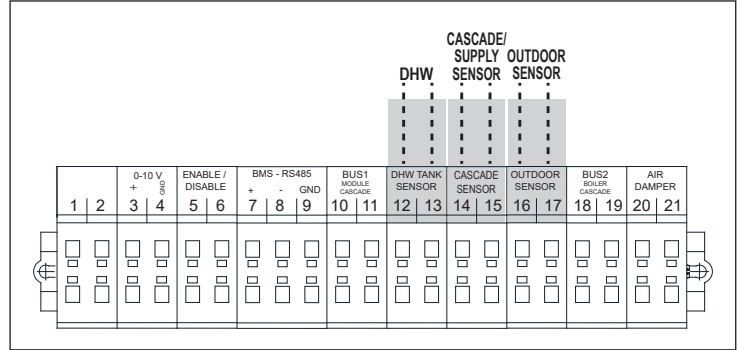

DEPENDENT CONNECTIONS

⚠ NOTE: Connections to be made on the first Dependent boiler only.

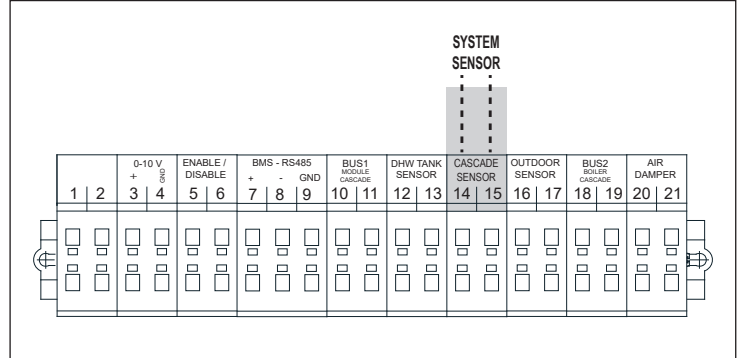

9.4.3 System parameters

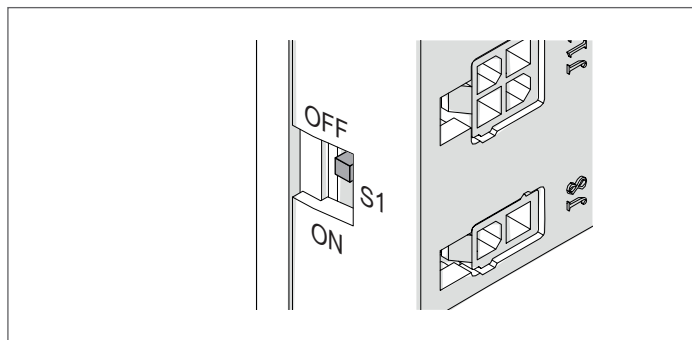

NOTE: See the section "9.5 Setting the main parameters" page 48 for a detailed description on parameter operation

Essential parameters to be configured:

	Description	Default	Managing	Dependent
S1	BUS power supply	Off	(*)	(*)
Dip-switch	Module Address	All 0	1 to ON	2-10 to ON
Par. 189	Burner Address	Stand-alone	Managing	Dep. 2-3...
Par. 147	Number of Units	8	TOT number of modules	(*)
Par. 73	Boiler Address	Stand-alone	Managing	(*)
Par. 167	Number of boilers	1	1	(*)
Par. 193	DHW for all	No	No	(*)
Par. 184	N. active burner in DHW	16	No. modules needed for DHW	(*)

(*) We do not recommend changing the default settings where not stipulated so as not to alter the operation of the appliance.

Specific parameters to be configured for the block diagram:

	Description	Default	Managing	Dependent
Par. 79	Max. Setp. Offset Down	2°C	(*)	(*)
Par. 80	Max Setp Offset Up	5°C	(*)	(*)
Par. 81	Start Mod. Delay Fact.	60 min	(*)	(*)
Par. 86	PID P	50	(*)	(*)
Par. 87	PID I	500	(*)	(*)
Par. 7	CH Hystereis Up	5	>10	>10

(*) Values recommended for optimum operation.

9.5 Setting the main parameters

Some parameters are essential in order for the system to operate in cascade and setting these parameters is a determining factor for correct system operation.

9.5.1 Par. 189 – module address (burner)

Parameter 189 sets the address with which the module (burner) is recognised and enables the primary sensor (SS).

Three values can be set:

- **Managing:** to be set on the Managing module so that primary sensor operation is activated.
N.B. Refer to the specific diagram to connect the sensor
- **Stand Alone:** to be set on the Managing module so that primary sensor operation is deactivated;
- **2 ÷ 7** to be set on all Dependent modules.

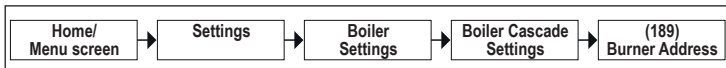

9.5.2 Par. 147 – no. of modules (burners)

Parameter 147 is for setting the number of connected modules (burners).

This parameter must only be set on the Managing module.

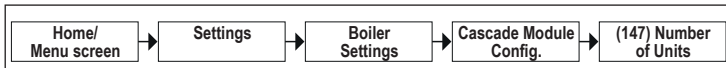

9.5.3 Par. 73 – Boiler address (cabinet)

Parameter 73 sets the address with which the boiler (cabinet) is recognised and enables the secondary sensor (SC).

Three values can be set:

- **Managing:** to be set on the Managing module so that secondary sensor operation is activated.
N.B. Refer to the specific diagram to connect the sensor
- **Stand Alone:** to be set on the Managing module so that secondary sensor operation is deactivated;
- **2 ÷ 7** to be set on all Dependent modules.

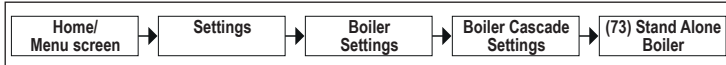

9.6 Par. 167 – no. of boilers (cabinets)

Parameter 167 sets the number of connected boilers (cabinets).

This parameter must only be set on the Managing boiler.

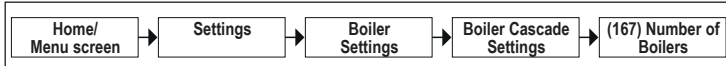

9.6.1 Par. 7 – heating setpoint hysteresis

The parameter 7 adjust shutdown of the individual modules when the setpoint is exceeded. With cascade operation, this value must be increased (up to a maximum of 20°C) to prevent module operation from being disabled (since the default value is 5°C) if the system decides to increase the setpoint based on the value read on the primary or secondary sensor (see explanation in paragraphs "General operation", "Operation with the primary sensor" and "Operation with the secondary sensor").

This parameter is to be modified (in the same way) on all modules of the cascade (Managing module and all the relative Dependent modules).

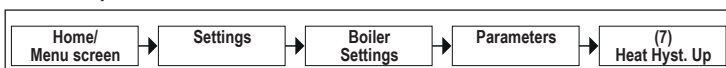

9.7 Configurable boiler error

To prevent any blocking cascade is it possible to configure some error to block only the single boiler and not the all cascade.

- a) Boiler error configured as "on" = Managing will turn off all cascaded modules if the error occurs.
- b) Boiler error configured as "off" = Managing will not stop the other modules in the cascade.

Eligible errors:

- LWCO_1_ERROR
- LWCO_2_ERROR
- GAS_PRESSURE_ERROR
- LOW_WATER_PRESSURE_ERROR
- AIR_DAMPER_ERROR
- AIR_DAMPER_LOCKING.

To set this error is necessary to proceed as follows:

- On the home screen of the control panel, press the "Menu" key
- Select "Settings" with the ▲ / ▼ keys and press the ● key
- Select "Boiler Error Settings" with the ▲ / ▼ keys and press the ● key
- Select the error with the ▲ / ▼ keys and press the ● key

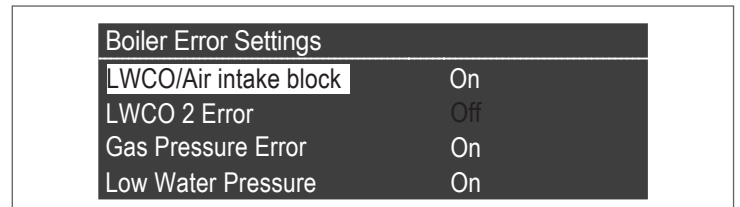
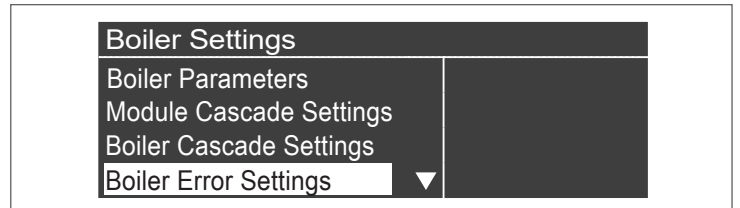
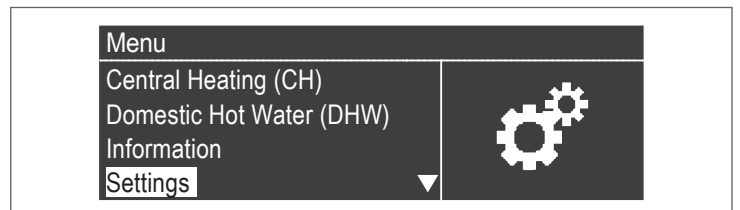
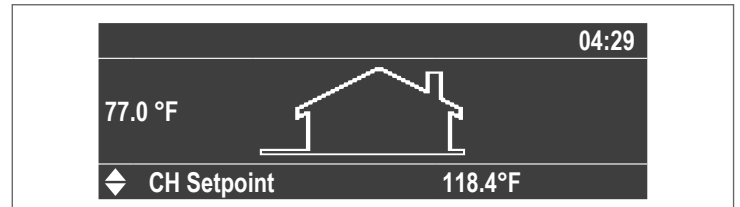

9.8 Par. 148: operating mode of the cascade

It is possible to adopt cascade management which can be modified according to different strategies. These different strategies can be set using the parameter known as "Cascade mode": Par. 148.

9.8.1 Par. 148 = 0

The start-up/shutdown law of each module is based on the following graph.

The shut-off values of the lines with the y axis are the sum or the difference of the values of the corresponding parameter in relation to the value of the setpoint sent by the Managing module to the modules.

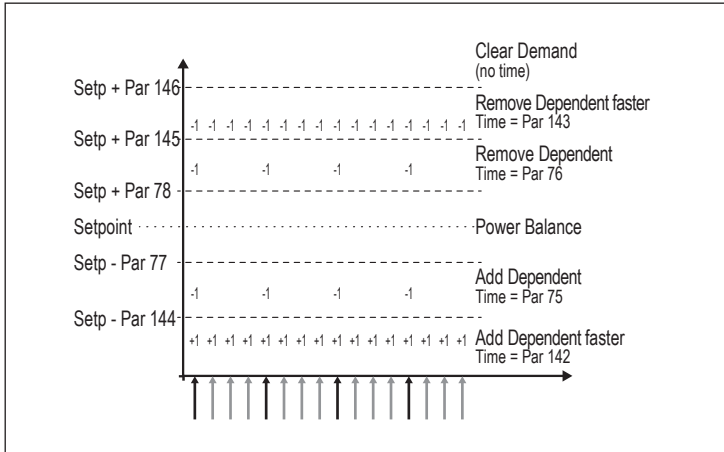

Six bands are defined on the basis of the temperature read (by the Managing module) on the delivery manifold of the primary system.

- In the central band **Power balance**, defined (by the variable parameters) around a setpoint, no start-ups or shutdowns of the Dependent modules are envisaged. The parameters which define this band are 77 and 78.
- In the band **Remove dependent** and **Add dependent**, the start-ups and shutdowns are carried out with "long" time intervals which can differ between start-up and shutdown. The parameters which define this band are 77, 78, 144, 145. The time interval is defined by parameters 75 and 76.
- In the band **Remove dependent Faster** and **Add dependent Faster**, start-ups and shutdowns are carried out with a "short" time interval which, even in this case, can differ between start-up and shutdown. The shutdown band is between the values of parameters 146 and 145, while the start-up band is below the value defined by parameter 144. The time range is defined by parameters 142 and 143.
- In the band **Clear demand**, all the modules are immediately stopped. This band is above the value defined by parameter 146.

9.8.2 Par. 148 = 1

In this mode the system manages the cascade so that the minimum number of modules is on. The first difference in relation to mode 0 refers to the logic with which the modulation of Dependent modules within the cascade is managed.

While each module modulates with its own PID in mode 0, no more than two dependent modules modulate with the same criteria in mode 1, while the remaining modules operate at maximum power. The diagram is represented in the following figure:

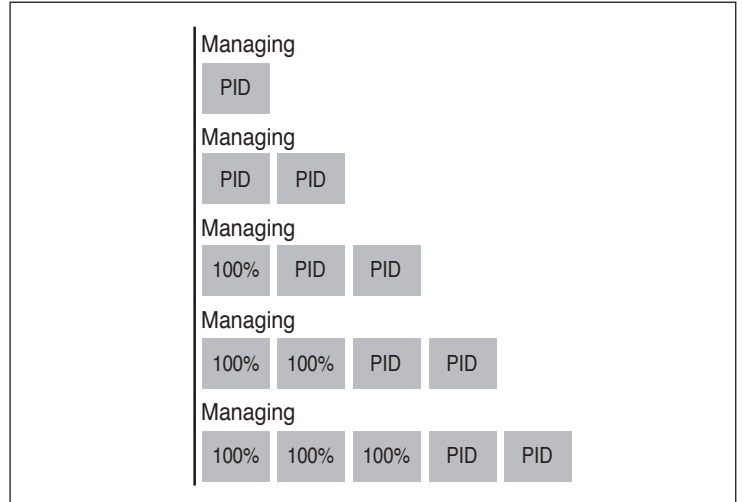

Practically speaking if more than two modules are on, only two modules are controlled via PID, while the others receive a signal to move to maximum power.

The second difference refers to the start-up/shutdown rules of the individual modules.

In any case, the start-up and shutdown rules are managed according to the indications shown in the previous graph. The difference is that it is also possible to have start-ups/shutdowns of the Dependent modules in the "balancing" zone.

This additional start-up criteria (valid in the balancing band only) ensures that a module is started-up when any one of the two modules controlled by a PID adjustment has reached a threshold power (Par. 82) once a specific wait time defined by Par. 75 has elapsed.

Similarly (still within the balancing band), a module is shutdown if both modules controlled by a PID adjustment have reached a percentage of power which is below the minimum power threshold (Par. 83) once a specific wait time defined by Par. 75 has elapsed.

9.8.3 Par. 148 = 2

In this mode the system manages the cascade so that the maximum number of boilers is on. This mode is similar to mode 0 apart from the start-up and shutdown rules.

In this case the rules based on the information illustrated by the previous graph are still valid, with the following differences (in any case, always applicable to the "balancing" option only):

To add an additional depending boiler, the managing boiler evaluates whether the sum of the power (calculated on the basis of the fan speed) of all the active boilers is greater than the product between the number of the active depending boilers increased by one and the minimum power value (Par. 152) increased by a hysteresis value (defined by Par 153). $[\sum (P_1, P_2, \dots, P_n) > (n+1) * (\text{Par. 152}) + (\text{Par. 153})]$.

To shutdown a boiler access, the managing boiler evaluates whether the sum of the power (calculated on the basis of the fan speed) of all the active boilers is less than the product between the number of the active depending boilers and the minimum power value (Par. 152). $[\sum (P_1, P_2, \dots, P_n) < (n) * (\text{Par. 152})]$.

NOTE: We must consider that the percentage of power varies from a minimum of 1% and a maximum of 100% and therefore, the parameter values 152 and 153 are not to be taken as the percentage of absolute power.

APPENDIX A – GAS TYPE CONVERSION

The heating unit is factory preset for operating with natural gas. This set-up can be changed using the conversion kits supplied by the manufacturer, on demand.

⚠ DANGER: To prevent risks of personal injury and property damage, this conversion shall only be performed by a trained and certified installer in accordance with the manufacturer's instructions and all applicable codes and requirements of the authority having jurisdiction. If the information in these instructions is not followed exactly, or the installation, adjustment, modification, operation or maintenance is carried out by an unqualified person, a fire, explosion or generation of excessive levels of carbon monoxide may result causing property damage, personal injury or loss of life. Before carrying out electrical work, disconnect the appliance from the power supply at the emergency shutoff switch or by disengaging the heating system circuit breaker. Take appropriate measures to prevent accidental reconnection. The installer is responsible for the proper conversion of this appliance. The conversion is not complete until the operation of the converted appliance is checked as specified in these instructions.

The gas-air ratio must always be set on the basis of a CO₂ or O₂ reading taken at maximum nominal output and minimum nominal output using an electronic flue gas analyzer. The desired high-fire excess O₂ level is 5.1% for natural gas.

Natural Gas to Propane Conversion Kit for AR 399 SE: Part #20185234
 Natural Gas to Propane Conversion Kit for AR 500 SE: Part #20185235

Switching from NATURAL GAS to LPG

- Close the gas shutoff valve
- Disconnect the electric power supply from the boiler

⚠ WARNING: To avoid electrical shock, it is mandatory to disconnect the boiler from the power supply using an external circuit breaker or disconnect switch.

- Open the front panels
- Change the mixer with new version present in the Conversion specific Kit.
- Unscrew the 4 screws (1) that connect the fan to the upper flange of the heat exchanger

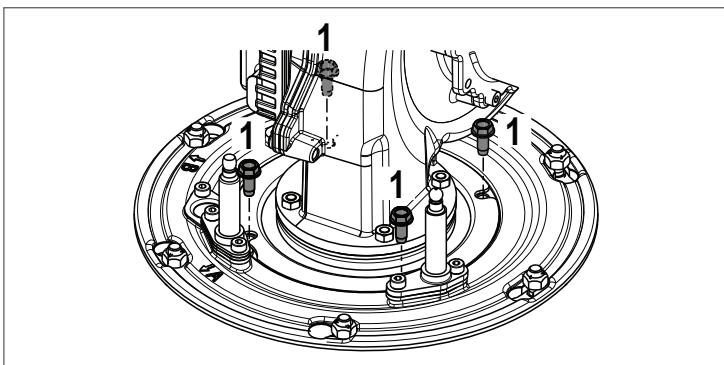

Fig. 58 NG mixer removal

- remove the tube (2), that connects the mixer and the gas valve

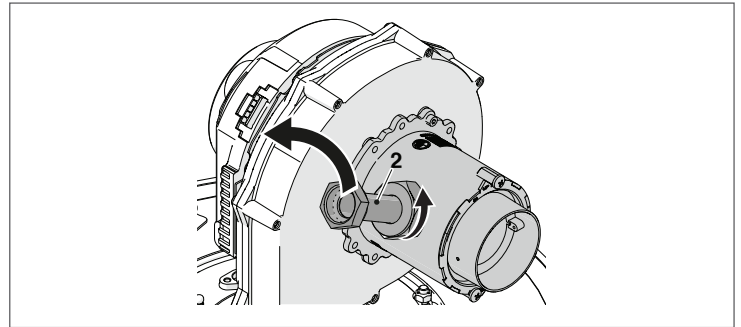

Fig. 59 NG mixer removal

- remove screws (3) in order to get out the mixer

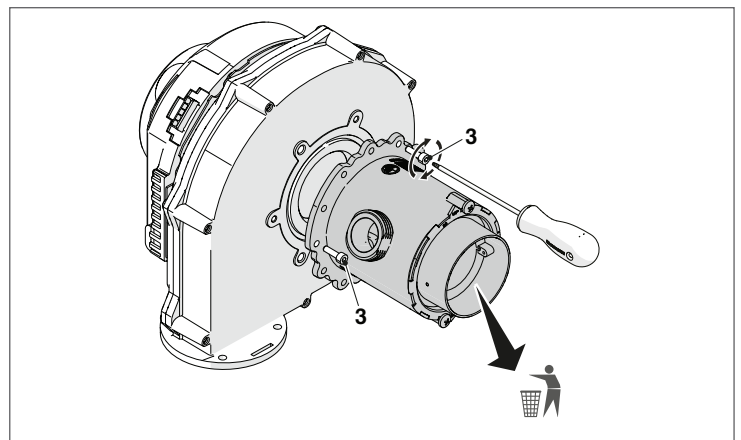

Fig. 60 NG mixer removal

- connect the LPG mixer (4) to the fan, putting in the O-ring (5) and screws (6)

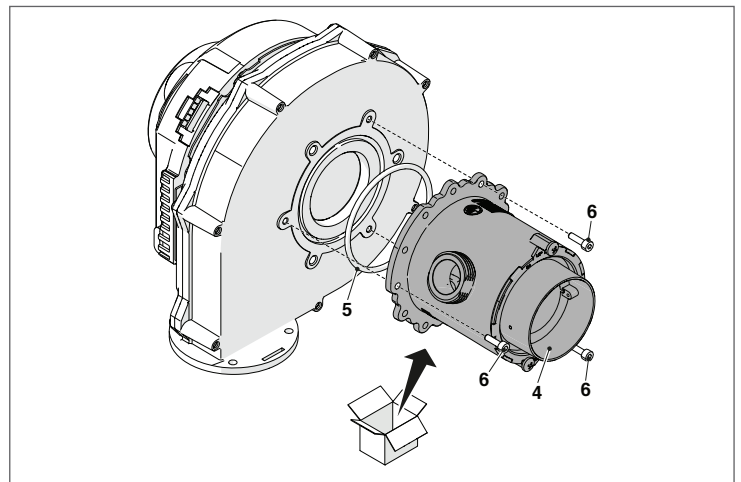

Fig. 61 LPG mixer installation

- reassemble the fan unit and the mixer by reversing the previous operations.
- Use the PB inner display to enter the appliance configuration menu and change the parameters #97 and #98:

Model	NG		LPG	
	AR 399 SE	AR 500 SE	AR 399 SE	AR 500 SE
Par. 98	83	82	84	82

APPENDIX B – MAINTENANCE

A qualified and adequately trained technician must perform the inspection as specified in these instructions before each heating season and at regular intervals.

Servicing, inspection and adjustment must be done by a trained technician in accordance with all applicable local, state and national codes. Improper servicing or adjustment of the boiler could result in equipment damage, injury, and/or dangerous conditions.

MAINTENANCE / INSPECTION SCHEDULE

Time interval	Maintenance
Annually	Verify the cleanliness of the area around the boiler
Annually	Check the pressure of the hydraulic system
Annually	Check vent piping and verify if leaks or obstructions are present
Annually	Check air piping and verify if leaks or obstructions are present
Monthly (follow local, state, federal or local authority having jurisdiction guidelines)	Verify the condensate discharge system
Every two months	Test low water cut off
Every two months	Inspect and test the reset button of low water cut off
Every six months	Check all piping (gas and water) for leaks
End of heating season	Shut off the boiler
Annually *	Combustion test and analysis
Annually *	Verify condition of flue and air system (including Venturi and fan)
Annually *	Check ignition electrode
Annually *	Clean the combustion chamber (including the burner tube)
Annually *	Clean condensate discharge
Annually *	Safety block check, modulation range check, gas valve closing after burner stop
Annually *	Check control parameters
Annually *	Check for gas piping leak
Annually *	Check wiring and connections
Annually *	Verify startup
Annually *	Verify the flame stability and signal strength
Annually *	Check relief valve
Annually *	Inspect the burner gasket

(*) Annually or every 2000 hours, whichever occurs first.

Gas Leak Inspection

Inspect all gas piping to confirm there are no leaks, including the pressure ports of the gas valves.

⚠ DANGER: To verify the gas leaks use a soap solution or a gas leak detector. Do not use matches, candles, or other methods that can cause a fire or explosion!

CHECK EXHAUST AND COMBUSTION AIR PIPE SYSTEM

Clear vent systems of any obstructions, corrosion, physical damage, water stains and rust. Verify the connection between the individual components.

Verify the outside terminations are clear. Clean the screens and the louvers if there is any debris.

INSPECTION OF IGNITION ELECTRODE AND IONIZATION ELECTRODE

Verify that the electrode is clean of deposits and use an emery cloth or other material to remove deposits as required.

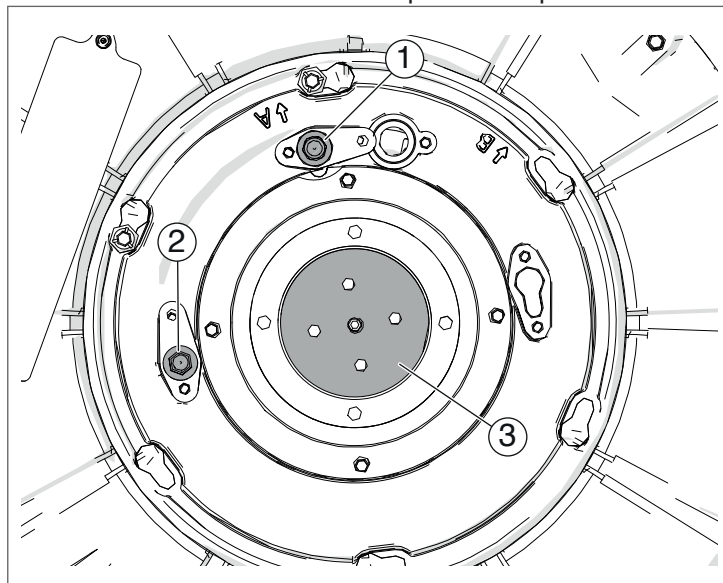

Fig. 62 Inspection of ignition electrode and ionization electrode

No.	Description
1	Ignition electrode
2	Ionization electrode
3	Burner tube

CHECK WIRING AND CONNECTIONS

Check that all wiring is securely fastened and in good condition without any cracking or alteration of isolation or presence of the insulation or corrosion on the metallic contacts.

BURNER GASKET INSPECTION

To ensure the reliability of the boiler/system, the boiler must be maintained as outlined in this manual and a qualified service technician must startup and service it at least annually.

This includes a combustion test and the cleaning of the combustion chamber.

When disassembling the heat exchanger it is crucial to inspect the Burner Gasket (part number OCR105917) for damage.

It is mandatory to replace the burner gasket when servicing and if there are any signs of wear, deformity or discoloration of the gasket and in any case not later than every two years.

GAS FILTER SERVICE

In order to ensure smooth operation:

- clean or replace the filter pad of the component annually or every 2000 hours, whichever occurs first;
- when cleaning or replacing the filter pad, no dirt may contaminate the clean gas circuit.

APPENDIX C - HEAD AVAILABLE FOR THE SYSTEM

HEAD AVAILABLE (NO GLYCOL)

Array	$\Delta T = 36^{\circ}\text{F}$	$\Delta T = 45^{\circ}\text{F}$
AR 399 SE	3,0 ft	10,0 ft
AR 500 SE	8,0 ft	20,0 ft

HEAD AVAILABLE (50% MAXIMUM GLYCOL)

Array	$\Delta T = 36^{\circ}\text{F}$	$\Delta T = 45^{\circ}\text{F}$
AR 399 SE	2,6 ft	8,5 ft
AR 500 SE	6,8 ft	17,0 ft

Array Model	Boiler Quantity	Combined Max GPM	Common Pipe Size (Inch)	Max Equivalent Length of Pipe (ft)
AR 399 SE	1	25	3	1800
	2	50	3	1200
	3	75	3	650
	4	100	3	350

Array Model	Boiler Quantity	Combined Max GPM	Common Pipe Size (Inch)	Max Equivalent Length of Pipe (ft)
AR 500 SE	1	30	3	1700
	2	60	3	900
	3	90	3	400
	4	120	3	60

NOTES:

Max equivalent length of pipes must account for all pipes, valves, fittings and a recommended strainer at boiler inlet.
Multiple boilers to be piped in reverse return layout.

APPENDIX D – VENTING SIZE DATA

While there is a positive flue pressure during operation, the combined pressure drop of vent and combustion air systems must not exceed the following equivalent length:

MODEL	PIPE SIZE – 4"		PIPE SIZE – 5"	
	MAX equiv. mt	MAX equiv. ft	MAX equiv. mt	MAX equiv. ft
ARRAY AR 399 SE	30	100	–	–
ARRAY AR 500 SE	20	65	30	100

Fittings as well as pipe lengths must be calculated as part of the equivalent length, according to the following table:

MODEL	45° ELBOW – 4"		45° ELBOW – 5"	
	MAX equiv. mt	MAX equiv. ft	MAX equiv. mt	MAX equiv. ft
ARRAY AR 399 SE	1.5	5	1.8	6
ARRAY AR 500 SE	1.8	6	2.4	8

MODEL	90° ELBOW – 4"		90° ELBOW – 5"	
	MAX equiv. mt	MAX equiv. ft	MAX equiv. mt	MAX equiv. ft
ARRAY AR 399 SE	3.4	11	4.3	14
ARRAY AR 500 SE	4.0	13	4.9	16

Data for Venting size

ARRAY AR 399 SE	T supply / return (F°) – 176 / 140				T supply / return (F°) – 104 / 86			
	Maximum Input		Minimum Input		Maximum Input		Minimum Input	
CO ₂	9%		9%		9%		9%	
Exhaust gas mass (weight)	6.56 lb/s		0.65 lb/s		6.56 lb/s		0.66 lb/s	
Flue temperature	161.6 °F		143.6 °F		107.6 °F		89.6 °F	
Max. pressure at boiler exit @ high fire condition	0,9 in H ₂ O	220 Pa	0,1 in H ₂ O	20 Pa	0,9 in H ₂ O	230 Pa	0,1 in H ₂ O	25 Pa

ARRAY AR 500 SE	T supply / return (F°) – 176 / 140				T supply / return (F°) – 104 / 86			
	Maximum Input		Minimum Input		Maximum Input		Minimum Input	
CO ₂	9,3%		9%		9,3%		9%	
Exhaust gas mass (weight)	7.99 lb/s		0.82 lb/s		7.99 lb/s		0.82 lb/s	
Flue temperature	161.6 °F		143.6 °F		107.6 °F		89.6 °F	
Max. pressure at boiler exit @ high fire condition	0,8 in H ₂ O	200 Pa	0,1 in H ₂ O	20 Pa	0,9 in H ₂ O	220	0,1 in H ₂ O	20 Pa

Cascade Venting of Multiple Boiler Installations

When multiple boilers of the same model size are installed within a common room it is permissible to cascade the venting connecting all boilers to a single exhaust system. No more than eight (8) boilers should be cascade vented together.

The boiler/ vent installation must be in compliance with ANSI Z223.1/ NFPA 54 and all local, state, and federal regulations for building code. Venting system shall be designed to maintain suitable vent pressure at the boiler exhaust collar.

For a list of suitable venting materials consult the installation manual section: "Venting material" page 60

Adapters are available for various brands of venting materials. Consult the factory for a list of available adapters.

Venting components from different manufacturers shall not be mixed.

Adequate combustion air must be supplied to the boiler to ensure safe operation. A properly sized direct connected common combustion air duct may be used for sealed combustion air to the boiler cascade.

For additional information regarding combustion air supply consult the installation manual section: "Combustion Air" page 60

Prior to installing a permanent vent system refer to the Installation Manual, ANSI Z223.1/ NFPA 54, and all local, state, and federal regulations for building code to ensure compliance with the requirements of these articles.

APPENDIX E – EXHAUST TERMINALS AND AIR INLET CLEARANCES

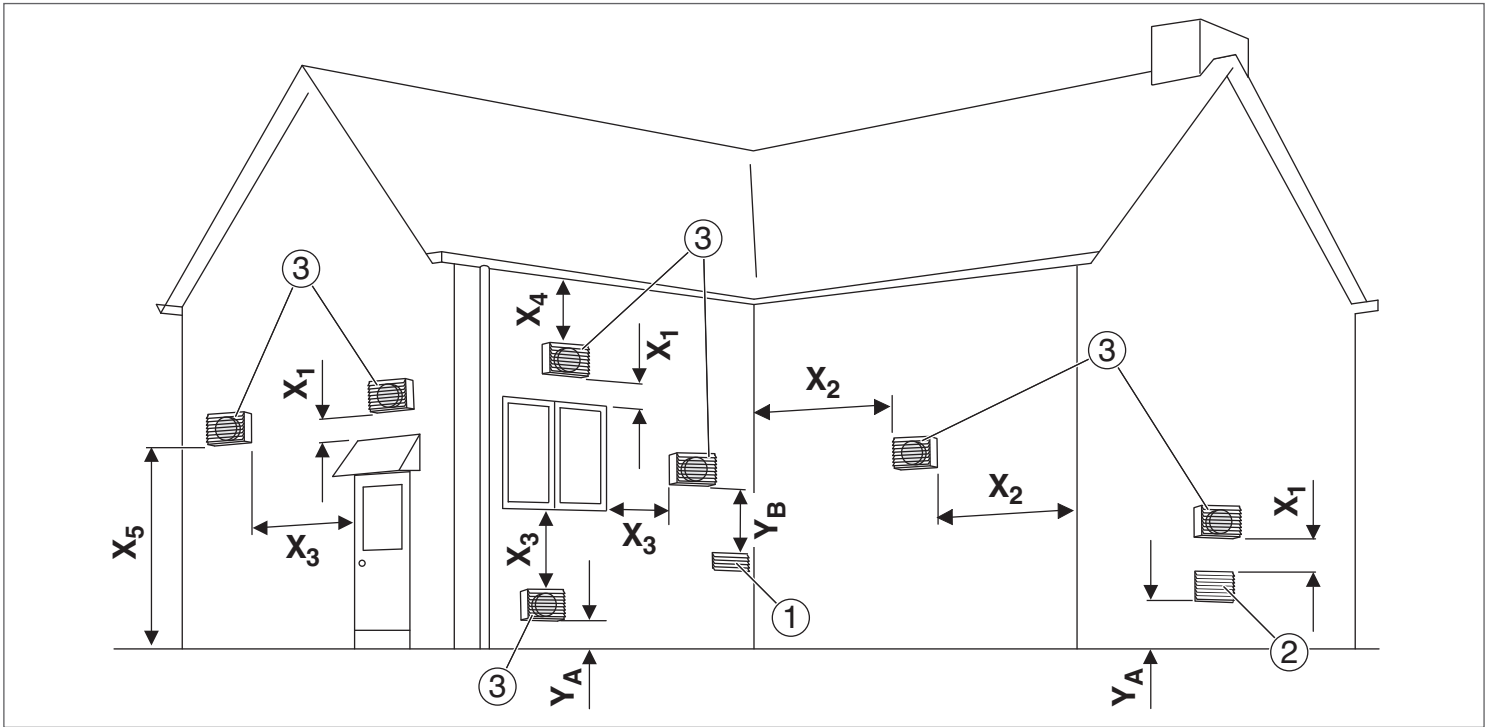

Direct vent (sealed combustion)

- 1 Forced air inlet
- 2 Gravity air inlet
- 3 Exhaust terminal
- X1 1 foot (305 mm)
- X2 See Note 1)
- X3 1 foot (305 mm) USA
3 feet (915 mm) Canada
- X4 See Note 1)
- X5 7 feet (2135 mm)
- YA At least 1 foot (305 mm) above grade or snow line
- YB Exhaust terminal must be at least:
3 feet (915 mm) above forced air inlet within
10 feet (3050 mm) horizontally – USA
3 feet (915 mm) above forced air inlet – Canada

- 1 Forced air inlet
- 2 Gravity air inlet
- 3 Exhaust terminal
- X1 1 foot (305 mm)
- X2 See Note 1)
- X3 1 foot (305 mm) USA
3 feet (915 mm) Canada
- X4 See Note 1)
- X5 7 feet (2135 mm)
- YA At least 1 foot (305 mm) above grade or snow line
- YB Exhaust terminal must be at least:
3 feet (915 mm) above forced air inlet within
10 feet (3050 mm) horizontally – USA
3 feet (915 mm) above forced air inlet – Canada

Fan assisted appliance (Room air for combustion)

It is not recommended to terminate vent above any door or window, condensate can freeze causing ice formations. Do not use chimney as a raceway if another boiler or fireplace is vented into or through chimney. All CPVC vent pipes must be glued, except for the flue gas adapter pipe connection. Vent terminations must keep the following minimum clearances from electric meters, gas meters, regulators and relief equipment: 4 feet (1220 mm) [Canada 6 feet (1830 mm)] horizontally and in no case above and below, unless a horizontal distance of 4 feet (1220 mm) [Canada 6 feet (1830 mm)] is maintained.

NOTE
1) For Clearances not specified in ANSI Z223.1 / NFPA 54 or CSA B149.1 Clearance in accordance with local installation codes and the requirements of the gas supplier including the Authority having jurisdiction.

APPROVED EXAMPLES OF HORIZONTAL AND VERTICAL VENTING INSTALLATION

⚠ NOTE: Place pipe supports a minimum of every 5 feet (1.525 mm) for horizontal and vertical runs, beginning with a support near the boiler unless the vent manufacturer or local code states smaller intervals. Venting shall also be supported at each connection point and 90 or 45 degree elbow. The first support shall be located close to the boiler. Ensure that proper venting supports are used for the vent type per the venting manufacturer's instructions. Failure to comply may cause vent separation resulting in a risk of carbon monoxide poisoning causing severe injury or death.

- Horizontal vent runs shall be supported where necessary to prevent sagging.
- Ensure horizontal vent runs have a upwards slope no less than 1/4 in/ft (21 mm/m) from the boiler to the vent terminal.
- The boiler and venting shall be installed so as to prevent accumulation of condensate; and where necessary, have means provided for drainage of condensate.
- The condensate must be disposed of in accordance with applicable code.
- Periodic cleaning of the vent terminal and air-intake screens is mandatory.
- Avoid locating vent terminals near equipment or building features which can be subject to degradation from exhaust gases.
- If multiple boilers are installed in a row, allow at least 1 foot (305 mm) clearance between the vent termination of one and the combustion air intake of the other.

In the following figures, the combustion air intake pipe is indicated with the number 1 (one) and the exhaust vent pipe with the number 2 (two).

Horizontal venting system (room air only)

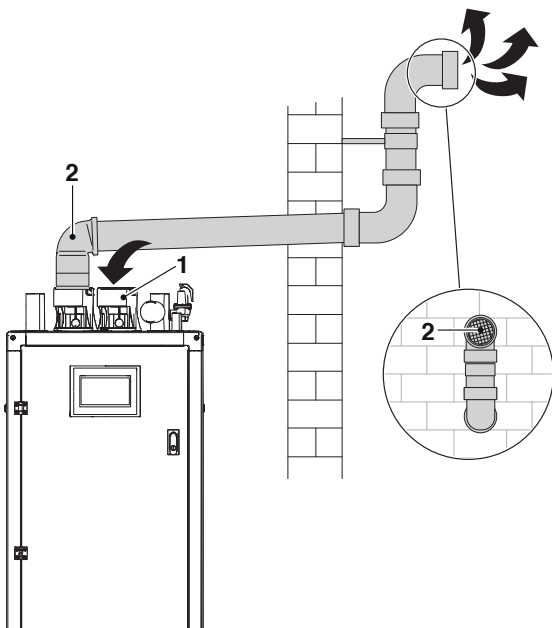

Horizontal venting system (room air only); $X \geq 4''$ (102 mm)

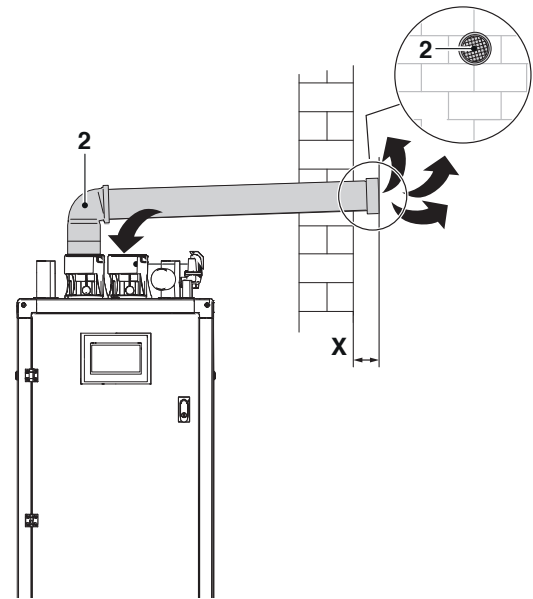

Vertical venting system (room air only); $X > 12''$ (305 mm); Y 12'' (305 mm) above maximum snow level or at least 24'' (610 mm) whichever is greater

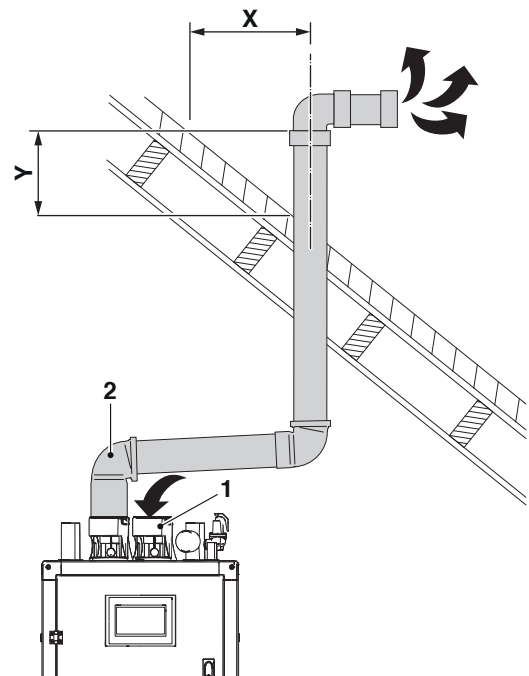

Horizontal venting system (sealed combustion); $X \geq 4''$ (102 mm); $Y \geq 12''$ (305 mm)

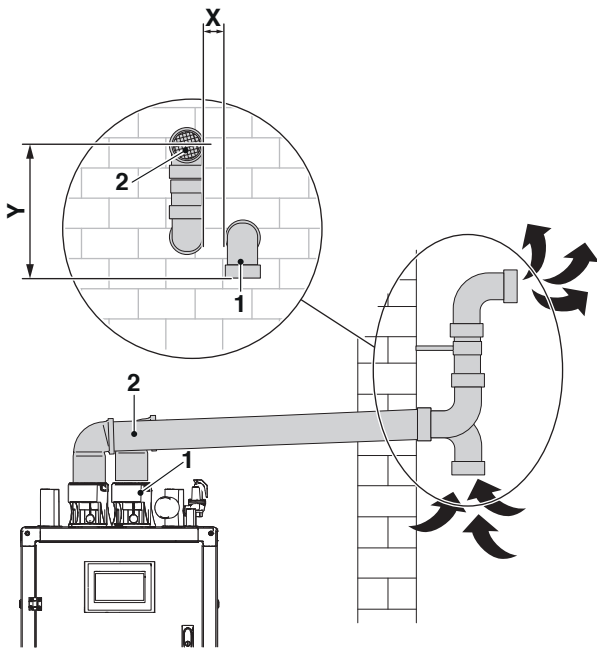

Vertical venting system (sealed combustion); $X > 12''$ (305 mm); Y 12'' (305 mm) above maximum snow level or at least 24'' (610 mm) whichever is greater

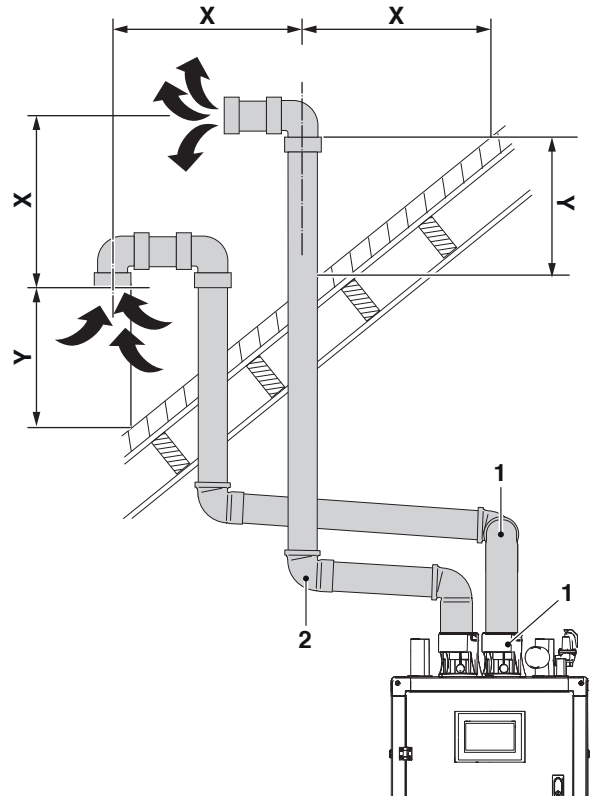

Vertical venting system (sealed combustion); Y 12'' (305 mm) above maximum snow level or at least 24'' (610 mm) whichever is greater

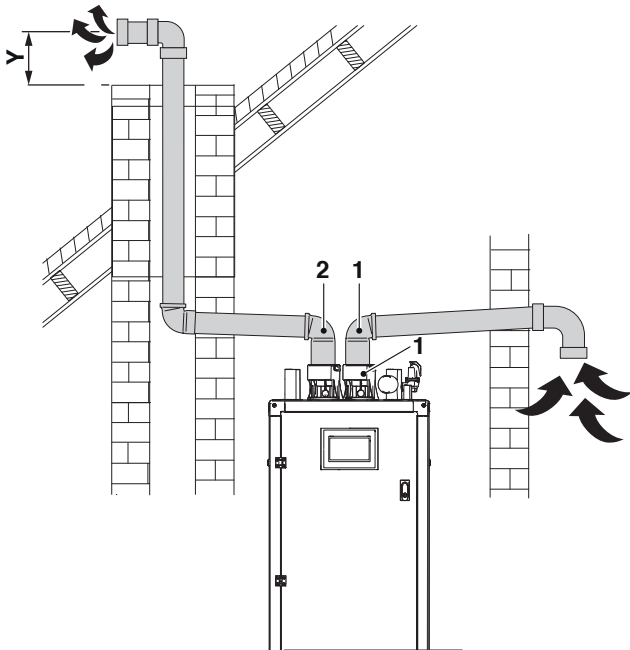

Horizontal venting system (sealed combustion)

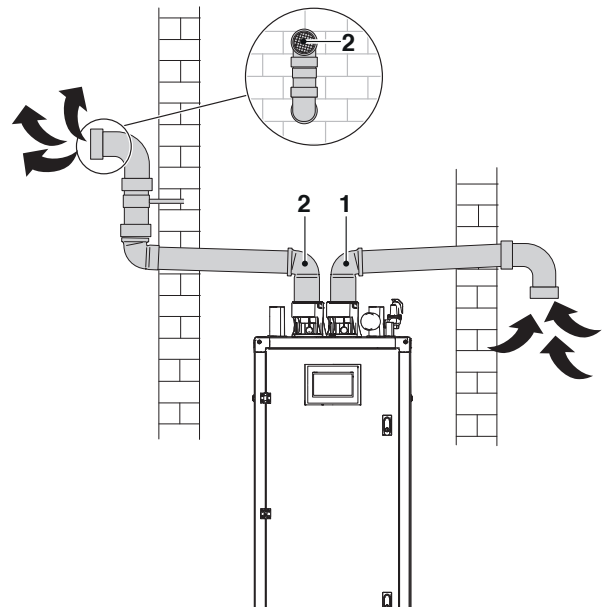

Horizontal venting system (sealed combustion); $X \geq 4''$ (102 mm)

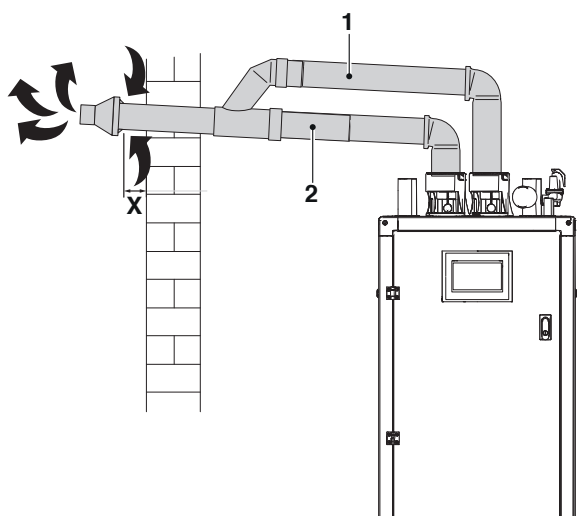

Vertical venting system (sealed combustion); $X > 12''$ (305 mm); Y 12'' (305 mm) above maximum snow level or at least 24'' (610 mm) whichever is great

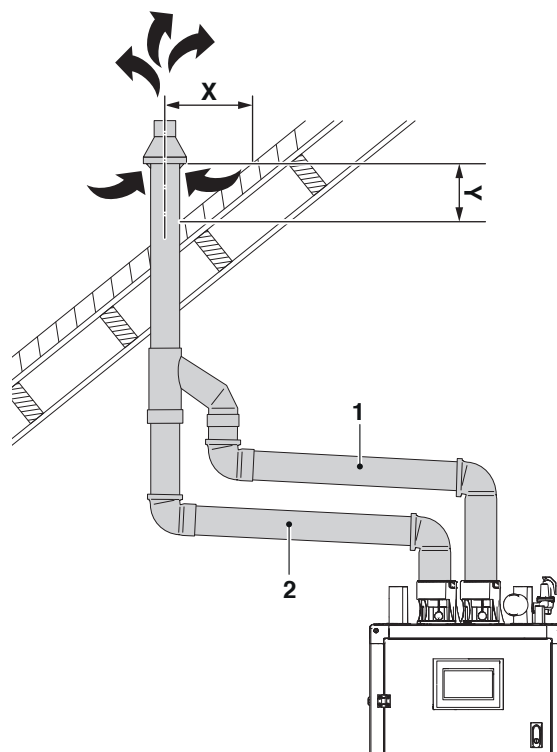

Horizontal concentric system (sealed combustion)

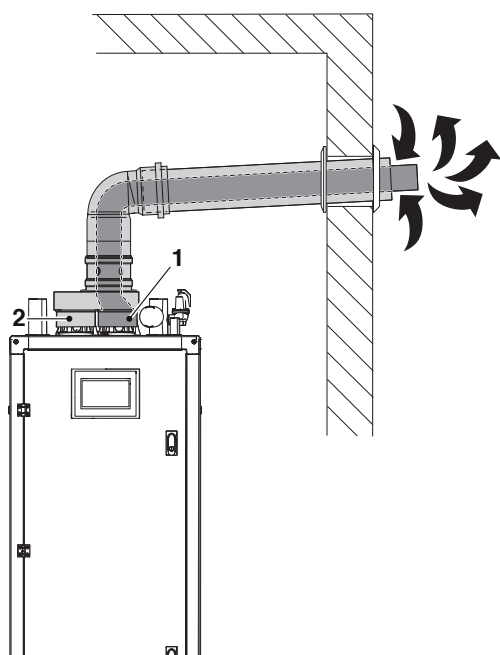

Vertical venting system (sealed combustion)

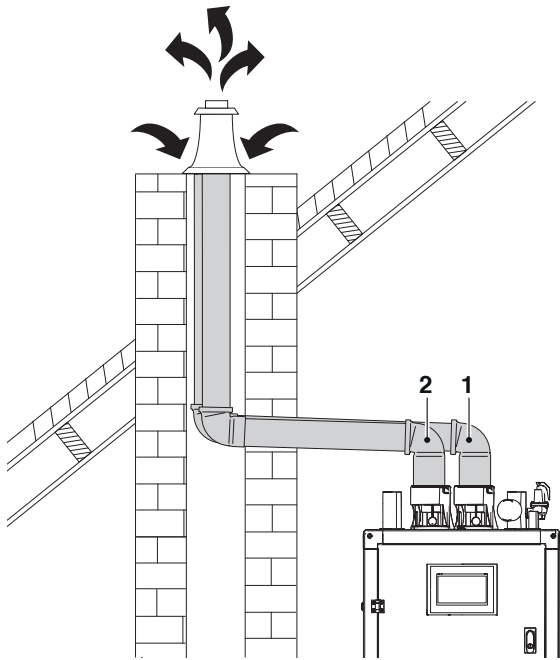

Vertical venting system (sealed combustion)

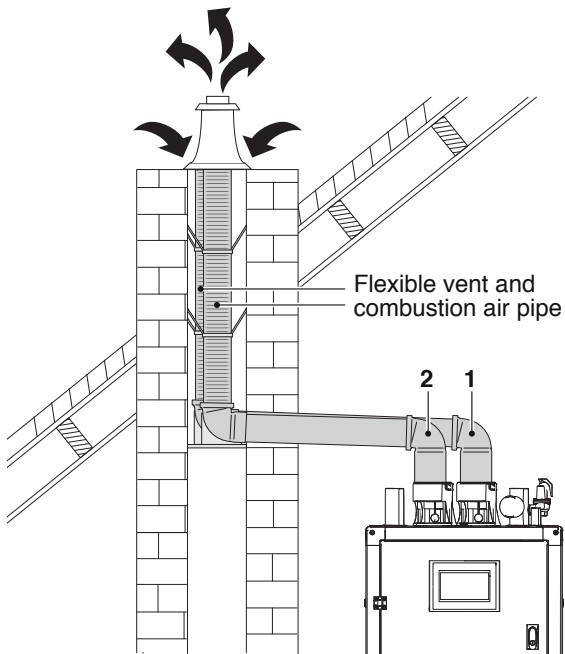

MULTIPLE BOILERS

- When installing multiple air and vent terminations, be sure that:
- The clearance between the vent and air termination are in accordance with the figures shown in this chapter
 - All vent pipes and air inlets must terminate at the same height

Concentric vent and combustion air vertical termination; $X \geq 12''$ (305 mm); $Y \geq 12''$ (305 mm) (18'' (457 mm) for Canada and/or per CAN/CSA B149.1) above highest snow level. Maximum 24'' above roof

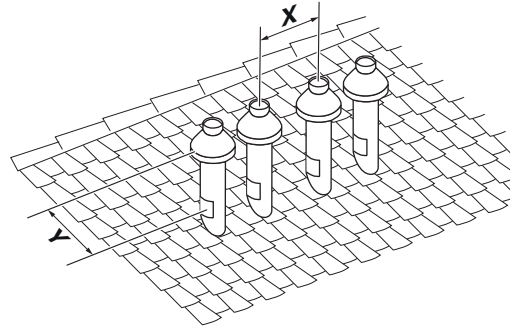

Concentric vent and combustion air horizontal termination; $X \geq 4''$ (102 mm); $Y \geq 24''$ (610 mm). Note: the terminations must all be level with each other and at a 12'' (305 mm) min from grade or the snow line.

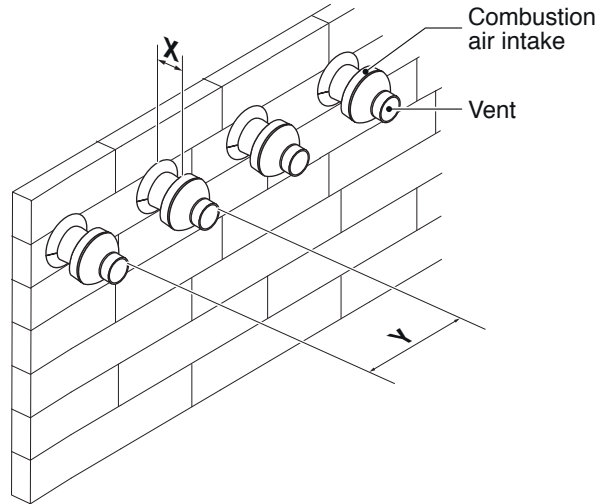

Multiple air and vent vertical terminations; $X \geq 12''$ (305 mm); $Y \geq 12''$ (305 mm)

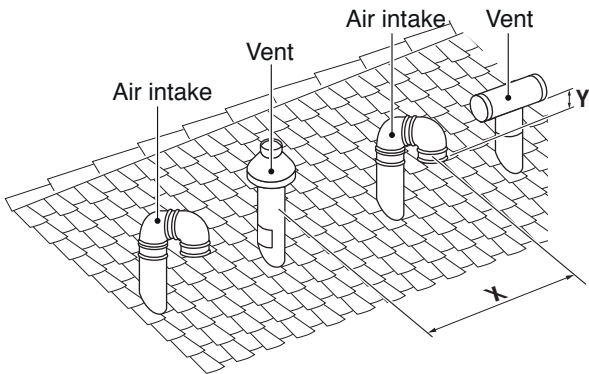

Multiple air and vent vertical termination ; $X \geq 12''$ (305 mm); $Y \leq 25''$ (635 mm); $Z = 12''$ (305 mm) to $16''$ (406 mm)

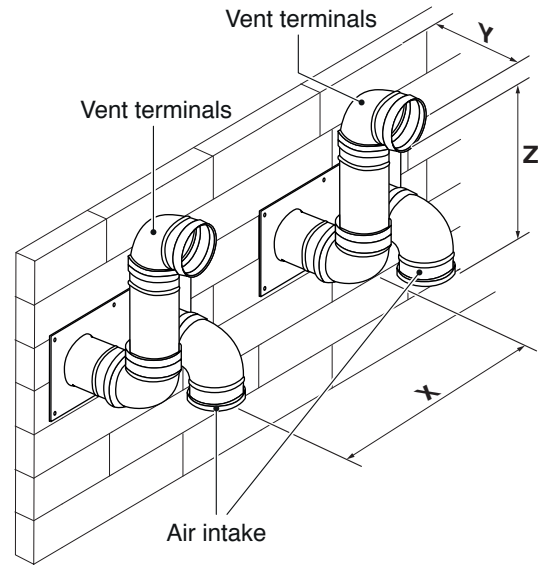

Multiple air and vent vertical termination; $X \geq 12''$ (305 mm); $Y \geq 12''$ (305 mm)

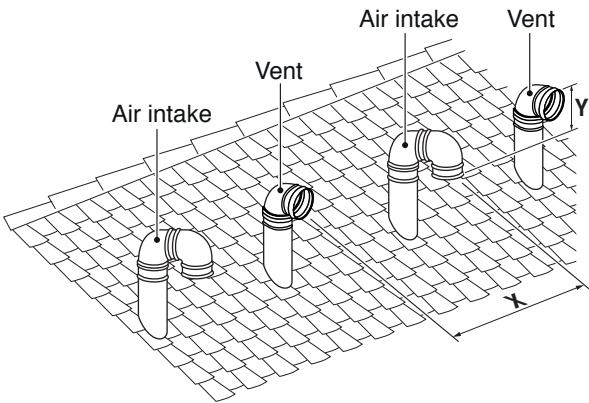

Multiple air and vent vertical termination; $X \geq 12''$ (305 mm); $Y \geq 12''$ (305 mm)

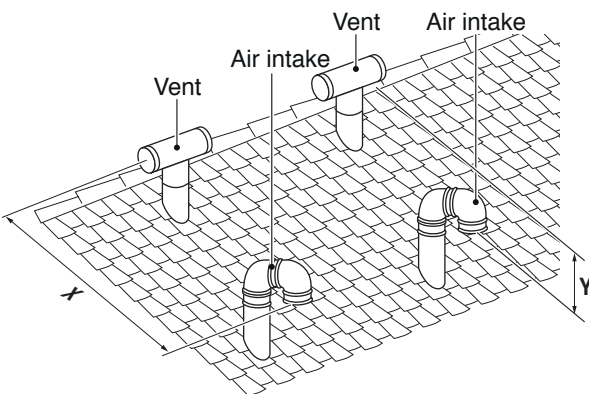

VENTING MATERIAL

Array boilers must be vented and supplied with combustion and ventilation air as described in this section.

Installation must comply with local requirements and with the National Fuel Gas Code ANSI Z223.1. **Array** boilers vent and intake air piping can be installed through the roof or through a sidewall. Any of the vent/air piping methods covered in this manual can be used. Do not attempt to install the boilers using any other means. Suitable, UL approved, positive pressure, watertight vent materials **MUST** be used for safety and UL certification.

Array boiler can use the following material for venting:

Material	Standard	Maximum Flue Temperature (°F)	Approved Manufacturers
CPVC Schedule 40, 80	ANSI/ASTM F441	194	
Polypropylene	ULC S636	230	Centrotherm Eco Systems (InnoFlue SW)
AL29-4C stainless steel	UL 1738	300+, limited only by rating of seals	

For specific venting components (terminals, fittings), contact the respective vent manufacturer.

⚠ DANGER: It is extremely important to follow these venting instructions carefully. Failure to do so can cause severe personal injury, death or substantial property damage.

⚠ DANGER: Use of cellular core PVC (ASTM F891), cellular core CPVC or Radel® (polyphenosulfone) in venting systems is prohibited.

⚠ WARNING: Do not connect this gas appliance with any other appliance unless approved by manufacturer. Failure to comply with this WARNING could result in the accumulation of carbon monoxide gas which can cause severe personal injury or death.

⚠ DANGER: The condensate traps must be filled with water or combustion gases will enter the room with a risk of an excessive level of carbon monoxide.

- Vent connectors serving appliances vented by natural draft shall not be connected to any portion of mechanical draft systems operating under positive pressure.
- Ensure the flue pipes and seals are not damaged.
- Use only primer and glue compounds approved for use with the vent material used.
- Never install a barometric or a thermally controlled vent damper with this boiler.
- Do not route the flue system piping through or inside another duct that is used for exhausting air or other flue gases.
- The condensate traps must be primed at all times. Failure to do so may allow combustion gases to escape into the boiler room.
- The unit is to be used for either direct vent installation or for installation using room air for combustion. When room air is used, it is necessary to provide an adequate opening for the fresh make-up air intake.
- You must use any of the vent/air piping methods shown in this manual.
- Be sure to locate the unit such that the vent and combustion air piping can be routed through the building and properly terminated.

- The boiler/vent installation must be in accordance with Venting of Appliances, of the latest edition of the National Fuel Gas Code, ANSI Z223.1/NFPA or applicable provisions of the local, state and federal building codes.
- All vent pipes must be installed according to the vent manufacturer's instructions.
- The exhaust vent and the combustion air inlet lines must be supported to prevent sagging per the vent manufacturer's instructions.
- The boiler must not support the weight of any ductwork.
- Do not mix components from different systems. The vent system could fail, causing leakage of flue products into the living space. Use only approved materials.
- Use of cellular core PVC and CPVC for venting system is not allowed.
- The vent system shall be installed so as to prevent the accumulation of condensate.
- Consult local and state codes pertaining to special building code and fire department requirements. Adhere to national code requirements.
- Observe the listed maximum lengths of vent system, which are boiler model dependent.
- To avoid moisture and frost build-up and to maintain clearances to openings on adjacent structures, 45° and 90° elbows or tees may be attached to the end of the vent termination pipe to direct exhaust plumes away from the adjacent structure. The total allowable vent length, maximum number of elbows and distance of air intake restrictions must be adhered to.
- Due to the high efficiency of the unit it may discharge what looks like white smoke especially when the outside air temperature is cold. This is due to the presence of water vapor, normally present in the exhaust gases.

COMBUSTION AIR

Air supply is a direct requirement of ANSI Z223.1, NFPA-54, CSA B149.1 and local codes. These codes should be consulted before a permanent design is determined.

Array boilers utilize combustion air from the space in which they are installed, or utilize combustion air ducted directly to the unit. Ventilation air must be provided in either case.

Material	Standard
ABS	ANSI/ASTM D1527
PVC Schedule 40	ANSI/ASTM D1785 or D2665
CPVC Schedule 40	ANSI/ASTM F441
Polypropylene	ULC S636
Single wall galvanised steel	26 gauge

In cold climates it is essential to provide a motorized air inlet damper to control the supply of combustion air and prevent nuisance condensation.

The combustion air must be free of:

- Permanent wave solutions;
- Chlorinated waxes/cleaners;
- Chlorine-based swimming pool chemicals;
- Calcium chloride;
- Sodium chloride used for water softening;
- Refrigerant leaks;
- Paint or varnish removers;
- Hydrochloric acid/muriatic acid;
- Cements and glues;
- Antistatic fabric softeners used in clothes dryers;

- Chlorine-type bleaches, detergents, and cleaning solvents found in household laundry rooms;
- Adhesives used to fasten building products and other similar products.

To prevent contamination do not connect the combustion air inlet and exhaust near:

- Dry cleaning/laundry areas and establishments;
- Swimming pools;
- Metal fabrication plants;
- Beauty shops;
- Refrigeration repair shops;
- Photo processing plants;
- Auto body shops;
- Plastic manufacturing plants;
- Furniture refinishing areas and establishments;
- Remodeling areas;
- Garages with workshops

Whenever the environment contains these types of chemicals, combustion air **MUST** be supplied from a clean area outdoors for the protection and longevity of the equipment and warranty validation. The more common methods of combustion air supply are outlined in the following sections.

COMBUSTION AIR FROM OUTSIDE THE BUILDING

Air supplied from outside the building must be provided through two permanent openings. For each unit these two openings must have a free area in accordance with the requirements of CAN/CSA B149.1, Natural Gas and Propane Installation Code. The free area must take into account restrictions such as louvers and bird screens.

COMBUSTION AIR FROM INSIDE THE BUILDING

When combustion air is provided from within the building, it must be supplied through two permanent openings in an interior wall. Each opening must have a free area of not less than one square inch per 1000 BTUH of total input or 3000 square inches of free area. The free area must take into account any restrictions, such as louvers.

DUCTED COMBUSTION AIR

For ducted combustion air installations, the air ductwork must be attached directly to the air inlet connection on the sheet metal enclosure.

In a ducted combustion air application, the combustion air ducting pressure losses must be taken into account when calculating the total maximum allowable venting length.

For additional details, see "Appendix D – Venting Size Data".

APPENDIX F – DE-RATING FOR ALTITUDE INSTALLATION

When the appliance is installed at an altitude higher than 2000 ft, the fan speed must be set to the maximum of the available range in any case and a de-rating of the input capacity must be considered in function of the altitude combined with the total length of the vent and combustion air pipe as reported in the following table (input BTU/hr).

NOTE: The following chart compensates for the affects of altitude on the energy content of the gas supply. No additional de-rate required.

ARRAY AR 399 SE

Altitude (ft)	From 0% to 25%	From 25% to 50%	From 50% to 75%	From 75% to 100%
0-2,000	399,220	399,22	399,22	399,22
3,000	383,251	376,48	369,83	363,30
4,000	367,921	361,42	355,04	348,77
5,000	353,204	346,97	340,84	334,82
6,000	339,076	333,09	327,21	321,43
7,000	325,513	319,76	314,12	308,57
8,000	312,493	306,97	301,55	296,23
9,000	299,993	294,69	289,49	284,38
10,000	287,993	282,91	277,91	273,00

ARRAY AR 500 SE

Altitude (ft)	From 0% to 25%	From 25% to 50%	From 50% to 75%	From 75% to 100%
0-2,000	500,000	500,00	500,00	500,00
3,000	480,000	471,52	463,20	455,02
4,000	460,800	452,66	444,67	436,82
5,000	442,368	434,56	426,88	419,34
6,000	424,673	417,17	409,81	402,57
7,000	407,686	400,49	393,41	386,47
8,000	391,379	384,47	377,68	371,01
9,000	375,724	369,09	362,57	356,17
10,000	360,695	354,32	348,07	341,92

To calculate the de-rating of the input capacity, follow this example:

The total equivalent length of the flue system is $55+35 = 90$ ft. The maximum equivalent length for this type of installation is 100 ft (see "Appendix D – Venting Size Data").

The % range is $90/100 = 90\%$. This value is within the 75% and 100%.

APPENDIX G – DISPLAY AND MAIN BOARD REPLACEMENT

System configurations must be performed only by the Technical Assistance Service or by personnel authorized by **RIELLO**.

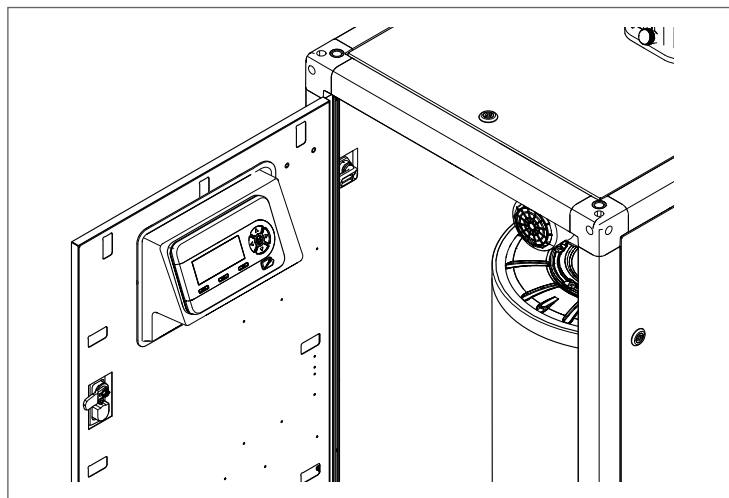

Fig. 63 Display board

When replacing the front control panel, an initial screen with the logo is displayed on the next reboot **RIELLO**.

The system performs a consistency check between the configuration data saved on the motherboard and those saved in the user interface; therefore, when replacing the control interface, the system can detect an inconsistency between the saved data. Set the Par. 97 and the Par. 98.

Proceed as follows:

- On the home screen of the control panel, press the ● key
- Select "Settings" with the ▲ / ▼ keys and press the ● key
- Select "Appliance configuration" with the ▲ / ▼ keys and press the ● key

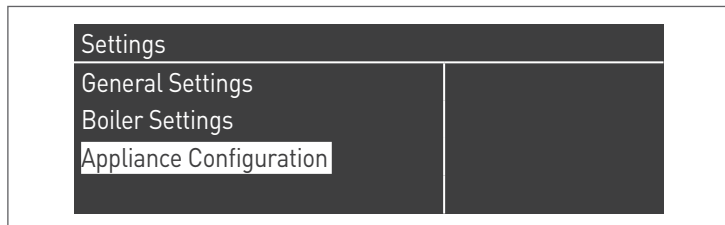

- Enter the password
- Select "(97) I/O Configuration" and press the ● button
- With the ▲ / ▼ keys change the value following what is in the following table and press the ● key:

Model	Par. 97	
	NG	LPG
AR 399 SE	52	52
AR 500 SE	52	52

⚠ If the unit is configured with an airdamper please reference to the specific paragraph for the configuration.

- Press the ▼ key, select "(98) Appliance Settings" and press the ● key

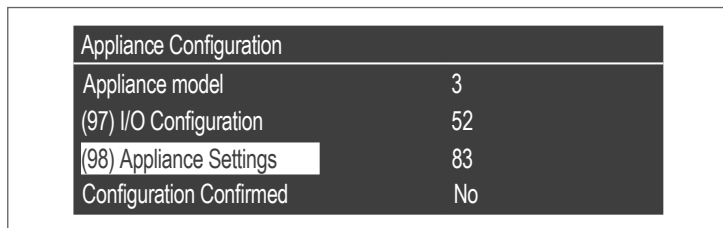

- With the ▲ / ▼ keys change the value following what is in the following table and press the ● key:

Model	Par. 98	
	NG	LPG
AR 399 SE	83	84
AR 500 SE	82	82

- Press the ▼ key, select "Configuration Confirmed" and press the ● key
- With the ▲ / ▼ keys change the value to "Yes" and press the ● key

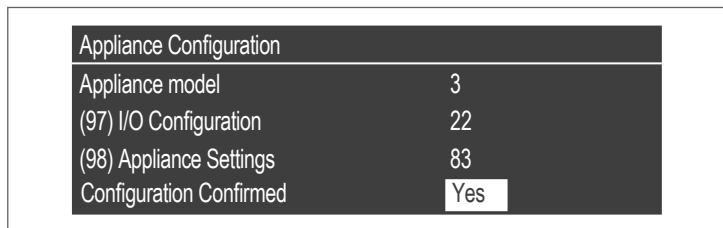

At this point the systems starts an application update process. Once this is finished, the menu "Settings" appears on the menu.

- Press ◀ until you return to the home screen

An error message is displayed for a few seconds and then the display returns to its normal state.

APPENDIX H – ELECTRONIC CONTROL

The electronic control interface menu is multi-level.

Navigation between the various levels is shown in the figures below.

Level 0 displays the Home Screen (Home). Level 1 displays the Main Menu screen. The subsequent levels are activated depending on available sub-menus. For the full layout, see section "Control panel". For how to access and change the parameters, see the picture on the next page. The parameters for the installer are accessible only after entering the security password (see section "Control panel!"). Please note that the boiler's operating parameters are identified with a number, all other additional functions are simply descriptive.

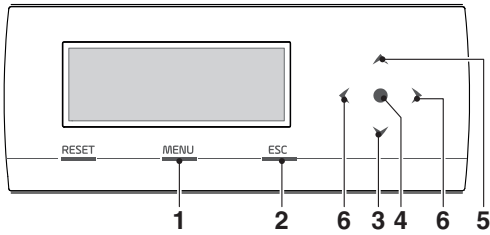

- 1 switches on the main menu
- 2 in menu navigation, it enables you to exit a menu item and go back to the previous one
- 3 supports selecting menus or parameters or decreasing numeric values
- 4 enter
- 5 supports selecting menus or parameters or increasing numeric values
- 6 supports moving to the RH/LH area of the display

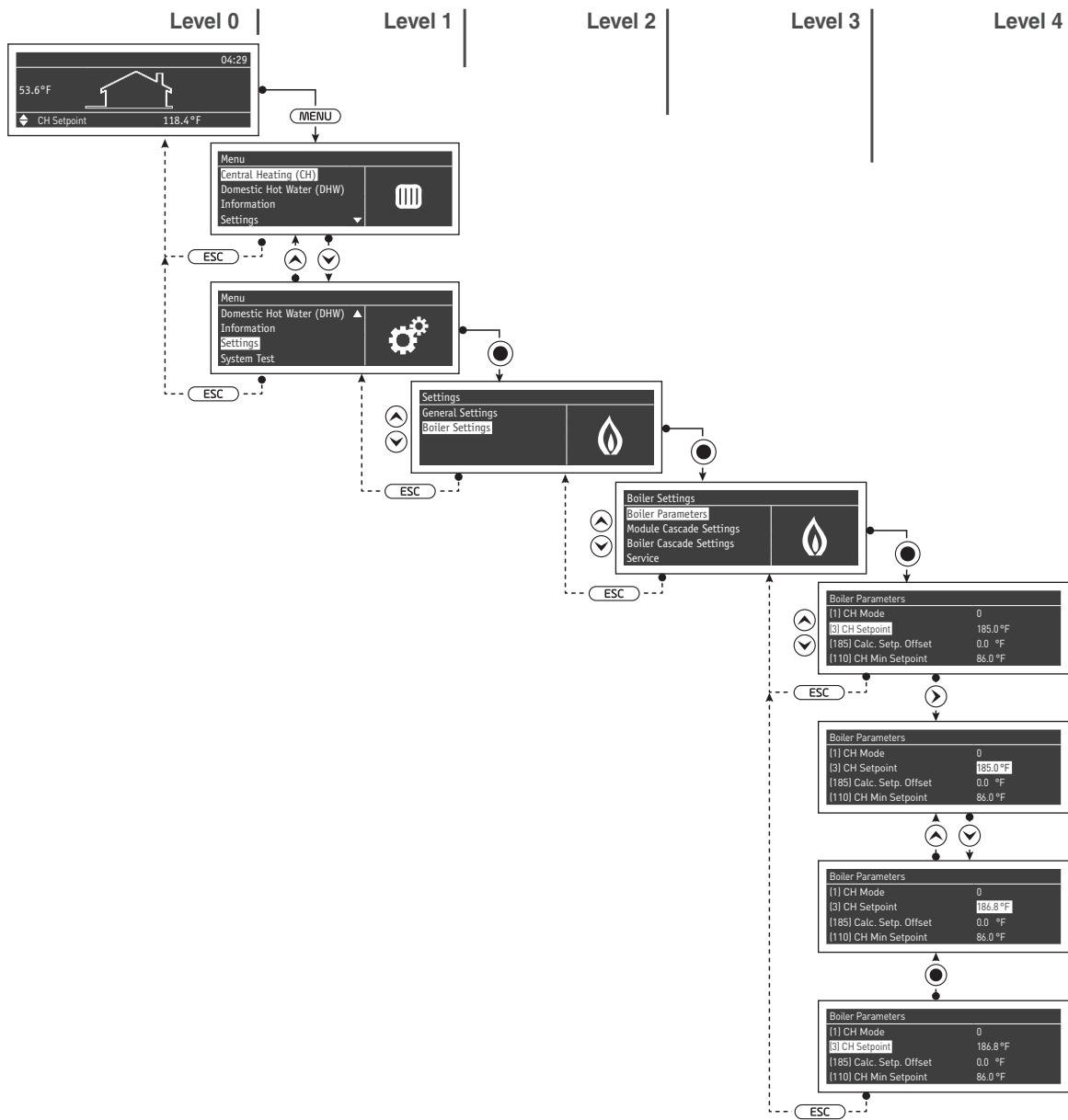

MENU STRUCTURE

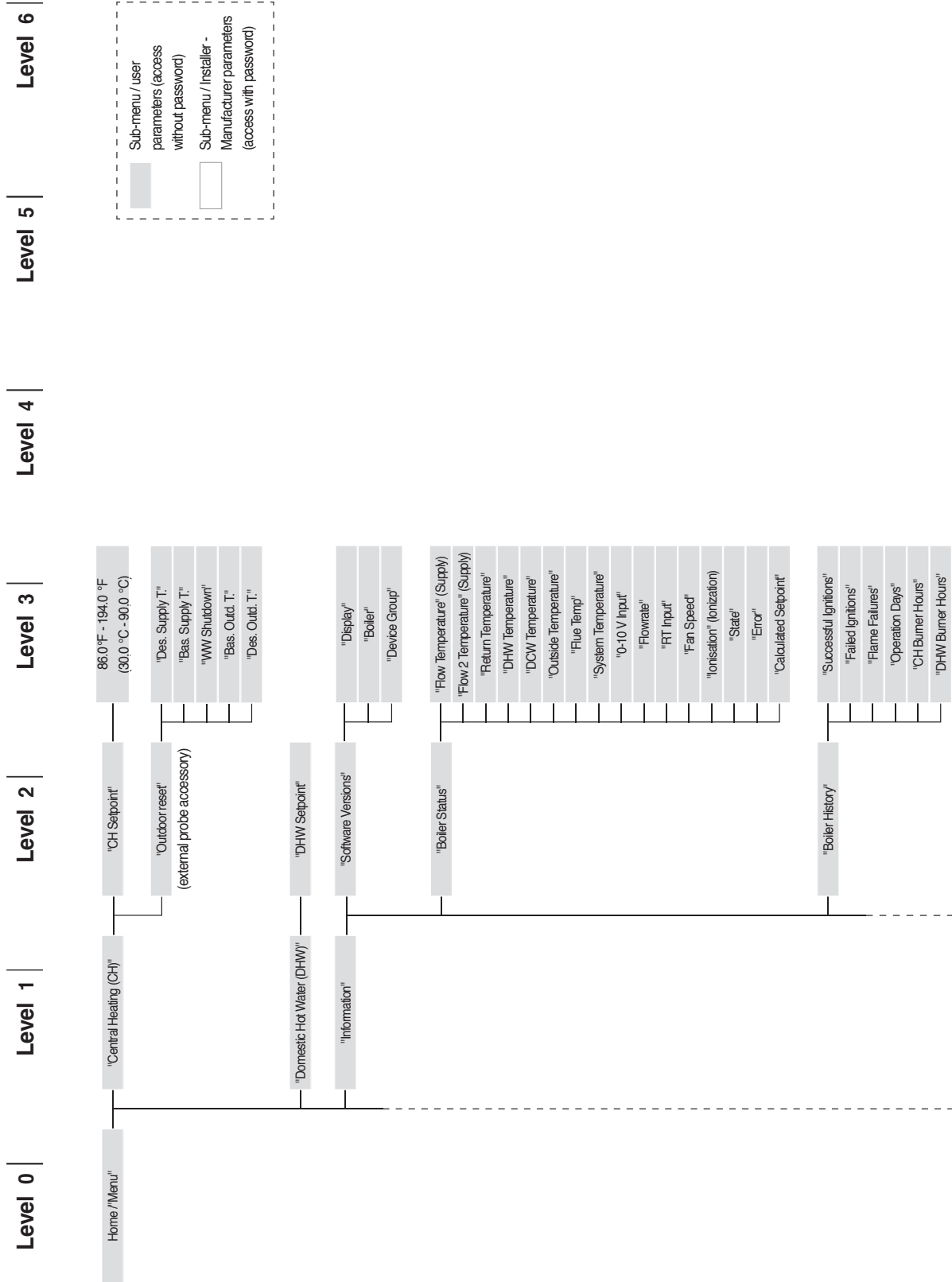

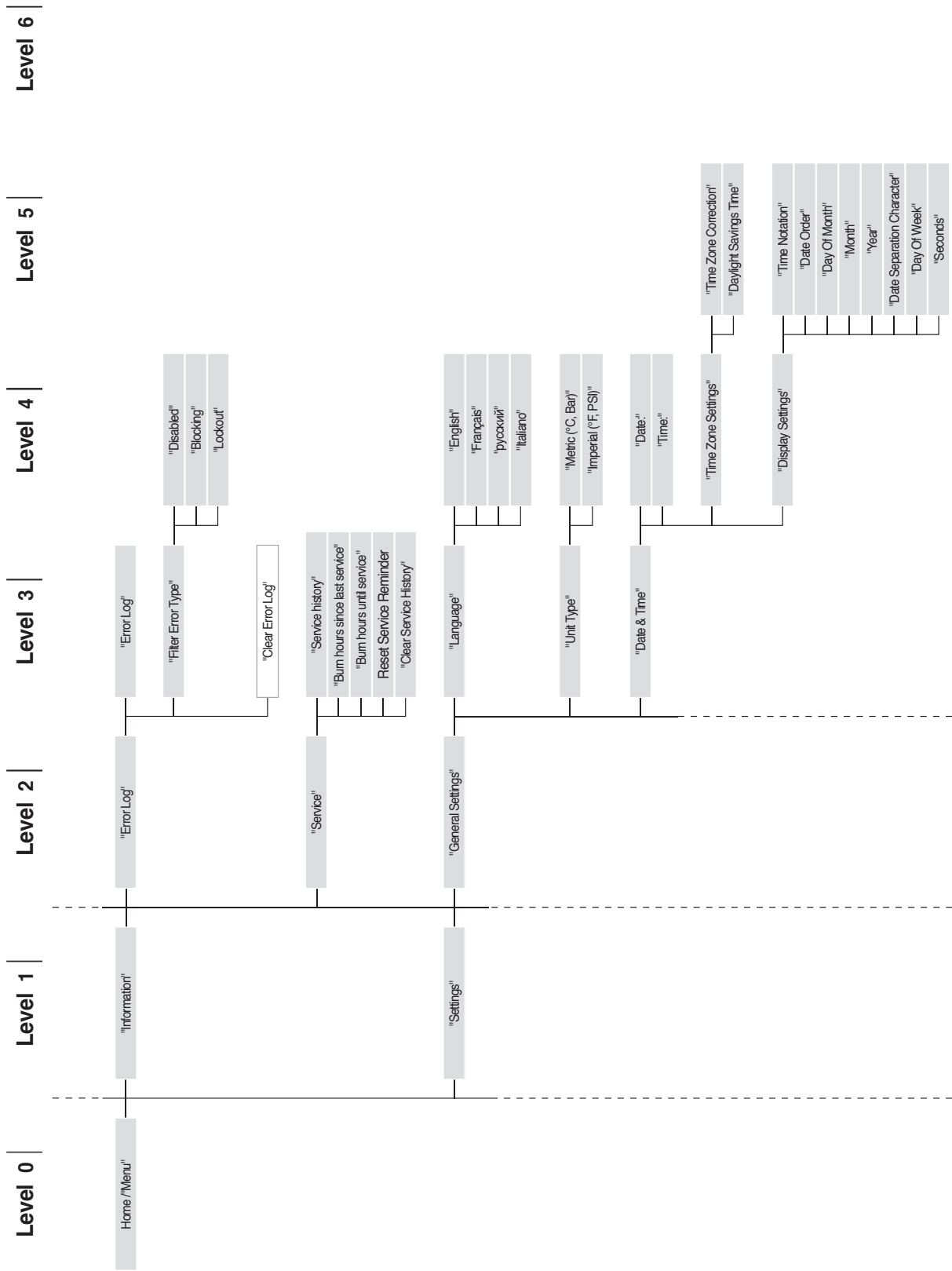

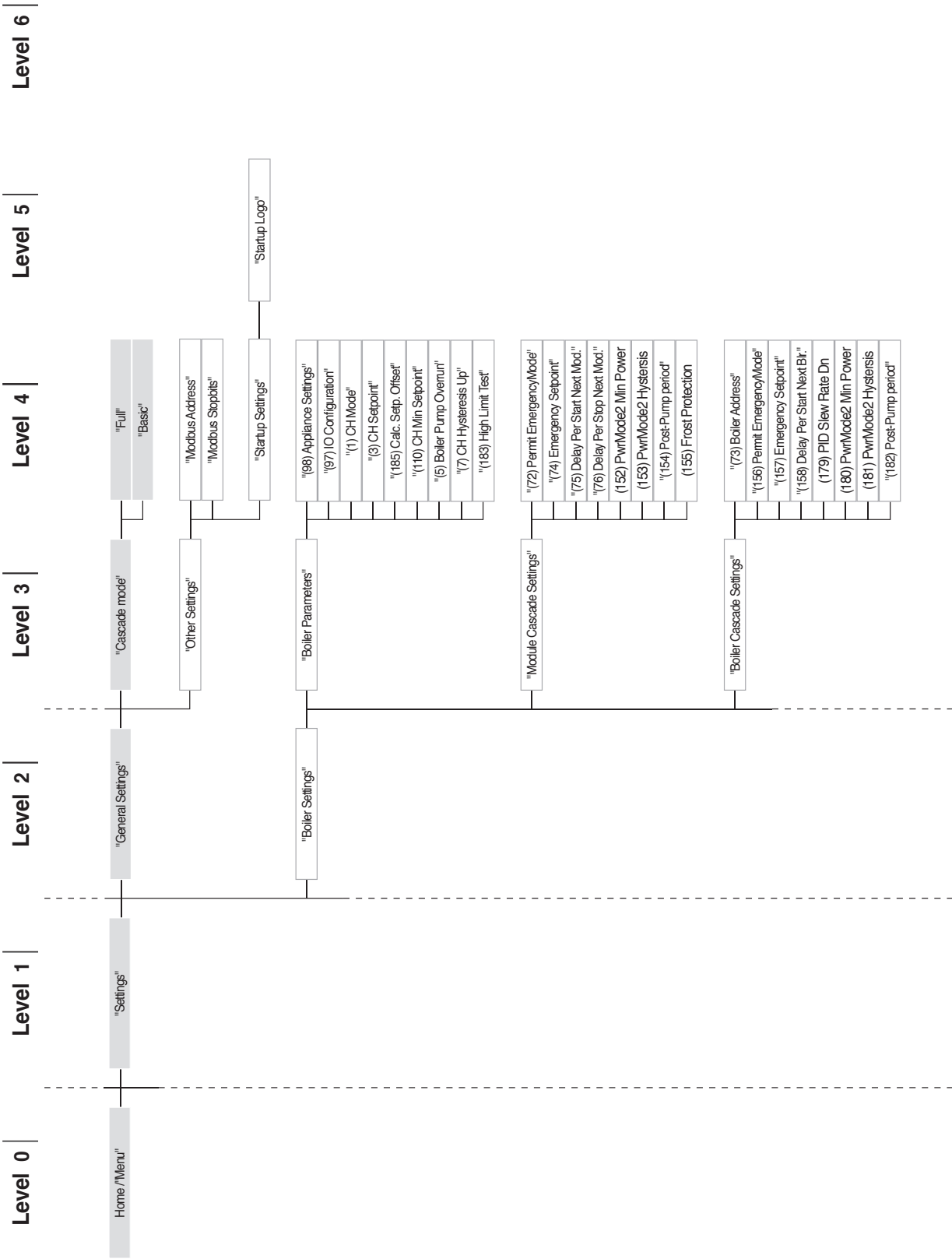

APPENDIX I – LIST OF PARAMETERS (WITH RANGES AND DEFAULT VALUES)

Parameters are listed base on the reference menu.

Reference Menu**M1** Parameters Menu**M2** Cascaded module configuration menu**M3** Cascaded boiler configuration menu**M4** Appliance configuration menuAccess type**U** End user**I** Installer**O** Manufacturer

Menu.	Par. No.	Display visualisation	Description	Range	Default setting	UM	Access type	Category
M1		CH Control	Enable or disable the heating circuit	Enabled/Disabled	Enabled		I	Heating
M1	1	CH mode	Defines the thermal module's various heating operation modes	0...5	0		I	Heating
M1	3	CH set-point	Defines the desired delivery temperature in heating mode (Par. 1) = 0	30...80 (86...176)	60 (140)	°C (°F)	U	Heating
M1	185	Calc. set-point off-set	It is possible to shift the climatic curve up and down. The calculated setpoint can be increased or decreased with a maximum of 10°C	-10...10	0	°C (°F)	I	Heating
M1	109	Comp. T. @ Bas. Outd	Establishes the setpoint offset value calculated in climatic mode (Par. 1= 1). Offsets the climatic curve in presence of mild outdoor temperatures	Off, -10...10	0		I	Heating
M1	110	CH Min. set-point	Defines the minimum delivery temperature at which the system operates in both heating and DHW mode	20...50 (68...122)	20 (68)	°C (°F)	I	Heating
M1	111	CH Max. set-point	Defines the maximum delivery temperature at which the system operates in both heating and DHW mode	50...90 (122...194)	90 (194)	°C (°F)	I	Heating
M1	190	Outd. Comp. Fact	"reserved"	0...100	0	%	I	Heating
M1	5	Boiler Pump Overrun	Sets the overrun time in seconds of the boiler's circulator during stand-alone operation; cascaded operation determines the module's overrun after switch-off due to temperature control	0...900	30	Sec	I	Heating
M1	6	Flue Temp. Limit	Sets the activation temperature when the maximum flue gas temperature is exceeded. When the flue gas temperature is higher than a set value, the module switches off and an error message is generated. When the flue gas temperature is in the interval between (Par. 6) -5°C and Par. 6, the module reduces its power in a linear way until it reaches minimum power when the temperature measured is equal to Par. 6	10...120 (50...248)	100 (212)	°C (°F)	O	General
M1	7	CH Hystereis Up	Sets the value in degrees beyond the setpoint at which the burner switches off for thermoregulation.	0...20 (32...68)	6 (10.8)	°C (°F)	I	Heating
M1	112	CH Hystereis Down	Sets the value in degrees below the setpoint at which the burner switches on again for thermoregulation	0...20 (32...68)	6 (10.8)	°C (°F)	I	Heating
M1	9	Anti-cycle Period	Sets the stand-by time before the appliance is switched on again after it switches off due to thermoregulation, independently from the delivery temperature dropping below the value indicated in Par. 10. Parameter valid only in stand-alone mode	10...900	180	Sec	I	Heating
M1	10	Anti-cycle Temp. Diff.	Sets the value in degrees below which the burner switches on again notwithstanding from the time spent at Par. 9	0...20 (32...68)	16 (28.8)	°C (°F)	I	Heating

Menu.	Par. No.	Display visualisation	Description	Range	Default setting	UM	Access type	Category
M1	12	Hx diff. Minimum	Sets the value of the temperature difference (Delta T) between the module's delivery and return temperature. For a Delta T value ranging between Par. 12 and (Par. 12) +8°C, the module reduces its power in a linear fashion until it reaches the minimum power. The minimum power is maintained until reaching (Par. 12) +8°C+5°C, after which the module switches off for a period of time equal to the value attributed to Par. 13; at the end of this time interval, the module switches on again	10...60 (50...140)	40 (72)	°C (°F)	0	General
M1	13	Hx Diff. Max. Wait Time	Defines the restart time after reaching the Delta T limit between delivery and return	10...250	10	Sec.	0	Heating
M1	14	Max. Power CH	Sets the heating's % max. power	50...100	100	%		Heating
M1	15	Min. Power CH	Sets the heating's % min. power.	1...30	1	%		Heating
M1	16	CH PID P	Defines the proportional parameter for modulation during heating operation	0...1275	50		0	Heating
M1	17	CH PID I	Defines the modulation integral term during heating operation	0...1275	500		0	Heating
M1	18	CH PID D	Defines the modulation derivative term during heating operation	0...1275	0		0	Heating
M1	19	Design supply Temp	Defines the max. setpoint at the minimum outdoor temperature for climatic regulation	30...90 (86...194)	90 (194)	°C (°F)	U	Heating
M1	20	Design Outdoor Temp	Defines the minimum outdoor temperature to which the maximum setpoint can be associated for climatic regulation	-25...25 (-13...77)	-5 (23)	°C (°F)	U	Heating
M1	21	Baseline Supply Temp	Defines the minimum set-point at the maximum outdoor temperature for climatic regulation	30...90 (86...194)	40 (104)	°C (°F)	I	Heating
M1	22	Baseline Outdoor Temp	Defines the maximum minimum outdoor temperature to which the minimum setpoint can be associated for climatic regulation	0...30 (32...86)	20 (68)	°C (°F)	I	Heating
M1	23	Design Supply Min. Limit	Limits the minimum value that can be assigned to the setpoint in heating mode (does not apply to heating mode 4)	4...82 (39...180)	30 (86)	°C (°F)	I	Heating
M1	24	Design Supply Max. Limit	Limits the maximum value that can be assigned to the setpoint in heating mode (does not apply to heating mode 4)	27...90 (81...194)	90 (194)	°C (°F)	I	Heating
M1	25	Warm Weather Shutdn	Defines the temperature at which climatic regulation is switched off	0...35 (32...95)	22 (71,6)	°C (°F)	I	Heating
M1	26	Boost Temp Increment	Establishes the setpoint temperature increase delta T, if the heat demand in heating mode is not satisfied after the time interval specified in Par. 27 (applies only to stand-alone mode)	0...30 (32...86)	0 (32)	°C (°F)	I	Heating
M1	27	Boost Time Delay	Defines the time interval after which the setpoint is increased as defined in Par. 26 (applies only to stand-alone mode)	1...120	20	Min.	I	Heating
M1	28	Night Setback Temp	Used in heating mode Par. 1= 2 or 3. Establishes by how many degrees the delivery setpoint is reduced when the RT (room thermostat/heat demand) contact is closed	0...30 (32...86)	10 (18)	°C (°F)	I	Heating

Menu.	Par. No.	Display visualisation	Description	Range	Default setting	UM	Access type	Category
M1	195	VVSD Enable	It is possible to enable/disable the shutdown of the entire system due to high external temperatures, both CH and ZH	Enabled/Disabled	Enabled		I	Heating
M1	193	DHW Control	Enable or disable the DHW circuit	Enabled/Disabled	Enabled		I	Heating
M1	35	DHW mode	Establishes the domestic hot water circuit's operation mode. 0 = Disabled 1 = Tank + sensor 2 = Tank + thermostat	0,1,2	0		I	DHW
M1	113	Max. Power DHW	Defines the domestic hot water circuit's % max. power	50...100	50	%	I	DHW
M1	114	Min. Power DHW	Defines the domestic hot water circuit's % minimum power	1...30	1	%	I	DHW
M1	36	DHW Tank Hyst. Down	Defines the hysteresis to initiate the domestic hot water demand	0...20 (32...68)	5 (9)	°C (°F)	I	DHW
M1	37	DHW Tank Hyst. Up	Defines the hysteresis to stop the domestic hot water demand	0...20 (32...68)	5 (9)	°C (°F)	I	DHW
M1	38	DHW Tank Supply Extra	Defines the primary circuit's setpoint increase in degrees compared to the temperature set for the domestic hot water tank	0...30 (32...86)	15 (27)	°C (°F)	I	DHW
M1	39	DHW Tank Supp Hyst Dn	Defines the primary circuit's restart hysteresis in modes 1 and 2 of domestic hot water (valid both for cascade and stand-alone applications)	0...20 (32...68)	5 (9)	°C (°F)	O	DHW
M1	40	DHW Tank Supp Hyst Up	Defines the primary circuit's shut-off hysteresis in modes 1 and 2 of domestic hot water (valid both for cascade and stand-alone applications)	0...20 (32...68)	5 (9)	°C (°F)	O	DHW
M1	41	DHW Tank Hold Warm	Defines the value of a storage cylinder's delta T required for temperature maintenance. For instance, if set at 3 degrees, when the storage cylinder is at a setpoint value minus 3 degrees, the thermal module is switched on at minimum power to maintain the temperature to the setpoint plus hysteresis. If this parameter is kept the same as Par. 36, this function is inactive and the thermal module is switched on to the maximum power envisaged for the DHW circuit	0...10 (32...50)	5 (9)	°C (°F)	O	DHW
M1	42	DHW Priority	Defines the priority type: 0 = Time: time priority between the two circuits defined by Par. 43; 1 = Off: priority for CH; 2 = On: priority for DHW; 3 = Parallel: parallel priority managed on the basis of the primary circuit's temperature compared to the heating circuit's setpoint	0...3	0 = Time		I	DHW
M1	43	DHW Max. Priority Time	Establishes the time in minutes during which priority is alternatively allocated to the DHW and CH circuits when Par. 43 is set to "time" mode	1...255	60	Min.	I	DHW
M1	44	DHW Pump Overrun	Establishes the overrun time in seconds for the domestic hot water mode with the boiler in stand-alone operation; cascaded operation defines the module's overrun after switch-off due to thermoregulation	0...900	0	Sec.	I	DHW
M1	45	DHW Tank PID P	Defines the proportional term for modulation during operation of the DHW storage tank	0...1255	100		O	DHW
M1	46	DHW Tank PID I	Defines the integral term for modulation during operation of the DHW storage tank	0...1255	500		O	DHW

Menu.	Par. No.	Display visualisation	Description	Range	Default setting	UM	Access type	Category
M1	47	DHW Tank PID D	Defines the derivative term for modulation during operation of the DHW storage tank	0...1255	0		0	DHW
M1	48	DHW tank setpoint	Establishes the DHW storage tank setpoint	40...71 (104...160)	50 (122)	°C (°F)	U	DHW
M1	49	DHW Hysteresis Down	"reserved"	0...20 (32...68)	4 (7.2)	°C (°F)	0	DHW
M1	50	DHW Hysteresis Up	"reserved"	0...20 (32...68)	4 (7.2)	°C (°F)	0	DHW
M1	51	DHW Instant PID P	"reserved"	0...1255	100		0	DHW
M1	52	DHW Instant PID I	"reserved"	0...1255	160		0	DHW
M1	53	DHW Instant PID D	"reserved"	0...1255	0		0	DHW
M1	60	Flow Rate Start	"reserved"	0.1...20	1.4	l/min	0	DHW
M1	61	Flow Rate Lo Temp Pwr	"reserved"	0.1...20	1.4	l/min	0	DHW
M1	62	Flow Rate Hi Temp Pwr	"reserved"	0.1...20	1.4	l/min	0	DHW
M1	63	DHW On Off Period	"reserved"	10...60	30	Sec.	0	DHW
M1	64	PreHeat Mode	"reserved"	Off, Comfort, Eco, Anti-Fr	Off		U	DHW
M1	65	PreHeat Mode Eco Setpoint	"reserved"	20...60 (68...140)	30 (86)	°C (°F)	0	DHW
M1	67	PreHeat After Tap Hld Time	"reserved"	0...255	30	Sec.	0	DHW
M1	68	After Tap Hold Time	"reserved"	0...255	120	Sec.	0	DHW
M1	69	PreHeat Hyst Down	"reserved"	0...30 (32...86)	5 (9)	°C (°F)	0	DHW
M1	70	PreHeat Hyst Up	"reserved"	0...30 (32...86)	0	°C (°F)	0	DHW
M1	71	PreHeat Delay Time	"reserved"	0...15	10	Sec	0	DHW
M1	92	Fan Speed Maximum	Defines the number of fan rpm at max. power (it depends on the model)	0...12750	6900	RPM	I	General
M1	93	Fan Speed Minimum	Defines the number of fan rpm at minimum power (it depends on the model)	0...12750	1900	RPM	I	General
M1	94	Fan Speed Ignition	Defines the number of fan rpm when the boiler is switched on (it depends on the model)	0...12750	4500	RPM	I	General
M1	116	Prog. Input 1.	"reserved"	0,1,2,3	Defined by Par. 97		I	General
M1	117	Prog. Input 2	"reserved"	0,1,2,3,4	Defined by Par. 97		I	General
M1	118	Prog. Input 3.	"reserved"	0,1,2	Defined by Par. 97		I	General
M1	120	Prog. Input 5	"reserved"	0,1,2	Defined by Par. 97		I	General
M1	121	Prog. Input 6	"reserved"	0,1,2,3	Defined by Par. 97		I	General
M1	122	Prog. Input 7	"reserved"	0,1,2,3,4,5	Defined by Par. 97		I	General
M1	123	Prog. Input 8	"reserved"	0,1,2	Defined by Par. 97		I	General
M1	188	Prog. Input 9	"reserved"	0,1,2	Defined by Par. 97		I	General
M1	124	Prog. Input RT.	0 = Disabled 1 = Enabled	0,1			I	General

Menu.	Par. No.	Display visualisation	Description	Range	Default setting	UM	Access type	Category
M1	125	Prog. Output 1	"reserved"	0,1,2,3,4,5,6,7,8,9,10,14,15,16,17,18,19,20	Defined by Par. 97		I	General
M1	126	Prog. Output 2	"reserved"	0,1,2,3,4,5,6,7,8,9,10,14,15,16,17,18,19,20	Defined by Par. 97		I	General
M1	127	Prog. Output 3	"reserved"	0,1,2,3,4,5,6,7,8,9,10,11,12	Defined by Par. 97		I	General
M1	128	Prog. Output 4	"reserved"	0,1,2,3,4,5,6,7,8,9,10,14,15,16,17,18,19,20	Defined by Par. 97		I	General
M1	187	Prog. Output 5	"reserved"	0,1,2,3,4,5,6,7,8,9,10,14,15,16,17,18,19,20	Defined by Par. 97		I	General
M1	129	Flow Sensor	Defines the type of flow sensor used	Bitron, Huba: DN8, DN10, DN15, DN20, DN25	Huba DN25		I	General
M1	130	Flow Scaling Factor	"reserved"	0...25.5	3.2	rpm/l	I	DHW
M1	131	Min Press.	"reserved"	Off, 0.3...5.0	0.1 (1.5)	bar (PSI)	I	DHW
M1	132	Pressure Fill Hyst.	"reserved"	Off, 0.2...5.0	0.5 (7.3)	bar (PSI)	I	DHW
M1	133	Mod. Pump dT	Defines the delta T set for the operation of the modulating circulator	5...40 (41..104)	15 (59)	°C (°F)	I	General
M1	134	Mod. Pump Start Time	Defines the time in seconds from the moment the burner is switched on to start the modulation of the circulator and obtain the delta T specified in Par. 133	0...255	120	Sec.	I	General
M1	135	Mod. Pump Type	Defines the PWM circulator model installed. 0 = Wilo 1 = Salmson 2 = Grundfos	0. Wilo Yonos 1. Salmson 2. Grundfos	0= Wilo		I	General
M1	136	Mod. Pump Mode	Defines whether the boiler's circulator operates in modulating mode or at a set speed (as a percentage of maximum speed)	0. On/Off 1. Modulating 2-10 Fixed 20... 100%	ON/OFF		I	General
M1	137	Mod. Pump Min Pwr	Defines the percentage of speed that sets the minimum speed that the circulator can reach during modulation	0...100	40	%	I	General
M1	139	Dair active	Activates bleeding the system's air. To activate air bleeding, it is necessary to switch on the boiler and change the parameter from "No" to "Yes". Wait for one minute. Switch off and restart. At this stage, when it is restarted the boiler will initiate the automatic bleeding procedure (lasting around 20 minutes). With the parameter set to "Yes", the procedure is carried out each time the boiler is switched off and restarted using its master switch. The value must be set to "No" if you do not wish to initiate the bleeding procedure when the thermal module is switched on	Yes, No	No		I	General
M1	140	Minimum Flow	Defines the flow rate below which the boiler is switched off. The value varies depending on the model	0.0...100 (0...26)	50	l/min	I	General
M1	196	HX flow timeout	If the minimum flow rate is not reached within the timeout, error 163 (LOWEXFLOW_PROTECTION) will be generated which will also cause the end of prepurge	4...100	18	Sec	I	General
M1	107	Anti-legionella Day	Sets the weekday on which the anti-Legionella procedure is carried out	Sun...Sat.	Sun		I	DHW
M1	108	Anti-legionella Hour	Sets the time of the day during which the anti-Legionella procedure is carried out	0...23	0	Hour	I	DHW
M1	183	High Limit Test	Enable limit thermostat physical test	Simulated/Physical	Simulated		0	General

Menu.	Par. No.	Display visualisation	Description	Range	Default setting	UM	Access type	Category
M1	155	Frost Protection	Defines the temperature (detected by the primary sensor) below which the thermal module circulator and the system circulator (with cascade configuration) activate. If the temperature of the primary sensor falls another 5 degrees below the value set by Par. 155, then a request to activate the cascade is generated. When the temperature of the primary sensor reaches the value defined by Par. 155 increased by 5 degrees, then the request ceases and the cascade returns to stand-by mode	10...30 (50...86)	15 (59)	°C (°F)	I	General
M1	186	Frost protection outdoor	It defines the intervention temperature of the antifreeze function related to the external probe	-30...15 (-22...59)	3 (37.4)	°C (°F)	I	General
M1	191	Fan Type	Defines the type of fan installed in the boiler	0...15	Defined by Par. 97		I	General
M1	193	DHW for all	"reserved"	No...Yes	No		I	DHW
M2	189	Burner address	It is used to address the module	Stand-alone (0) Managing (1) Dep. (2...16)	Stand alone (0)		I	DHW
M2	194	Dipswitch Config.	Enable or disable the dipswitch function	Enabled/Disabled	Enabled		I	Cascade
M2		Boiler demand disabled	All requests for this boiler are disabled	Yes/No	No	.	I	Cascade
M2	72	Permit Emergency Mode	Activates the emergency mode. This mode comes on when communication between Managing and the primary circuit's probe is lost. In this event, if Par. 72 is set to "Yes", the cascade is initiated, working to the fixed setpoint determined by Par. 74	Yes/No	Yes	.	U	Cascade
M2	74	Emergency Set-point	Setpoint active in emergency mode	20...90 (68...194)	70 (158)	°C (°F).	I	Cascade
M2	75	Delay Per Start Next Mod	Defines the stand-by time in seconds to restart the subsequent cascade module in normal start mode	5...255	120	Sec.	I	Cascade
M2	76	Delay Per Stop Next Mod	Defines the stand-by time in seconds to switch off the last cascade module on in normal Off mode	5...255	180	Sec	I	Cascade
M2	142	Delay Quick Start Next	Defines the stand-by time in seconds to restart the next cascade module in quick start mode	5...255	50	Sec	I	Cascade
M2	143	Delay Quick Stop Next	Defines the stand-by time in seconds to switch off the last cascade module on in Quick Stop mode	5...255	30	Sec	I	Cascade
M2	77	Hyst Down Start Module	Defines by how many degrees the temperature measured by the primary circuit's probe must fall below the setpoint in order for the subsequent module to be started after the time interval set by Par. 75	0...40 (32...104)	5 (9)	°C (°F)	I	Cascade
M2	78	Hyst Up Stop Module	Defines by how many degrees the temperature measured by the primary circuit's probe must go above the setpoint in order for the subsequent module to be switched off after the time interval set by Par. 76	0...40 (32...104)	4 (7.2)	°C (°F)	I	Cascade
M2	147	Number of Units	Defines the number of modules of which the cascade consists	1...16 (basic cascade) 1...8 (full cascade)	8		I	Cascade
M2	144	Hyst Down Quick Start	Defines by how many degrees the temperature measured by the primary circuit's probe must go below the setpoint in order for the subsequent module to be started after the time interval set by Par. 142 (quick-start mode)	0...40 (32...104)	10 (18)	°C (°F)	I	Cascade

Menu.	Par. No.	Display visualisation	Description	Range	Default setting	UM	Access type	Category
M2	145	Hyst Up Quick Stop	Defines by how many degrees the temperature measured by the primary circuit's probe must go above the setpoint in order for the subsequent module to be switched off after the time interval set by Par. 143 (quick stop mode)	0...40 (32...104)	6 (10.8)	°C (°F)	I	Cascade
M2	146	Hyst Up Stop All	Defines by how many degrees the temperature measured by the primary circuit's probe must go above the setpoint in order for all "On" modules to be switched off at the same time	0...40 (32...104)	8 (14.4)	°C (°F)	I	Cascade
M2	148	Power mode	Defines the cascade operation mode 0 = Disabled 1 = Min burners 2 = Max burners	0,1,2	2		I	Cascade
M2	79	Max. Setp. Offset Down	Defines the maximum decrease in the primary circuit's cascade setpoint. Is based on the primary circuit's probe reading	0...40 (32...104)	4 (7.2)	°C (°F)	I	Cascade
M2	80	Max Setp Offset Up	Defines the maximum increase in the primary circuit's cascade setpoint. Is based on the primary circuit's probe reading	0...40 (32...104)	4 (7.2)	°C (°F)	I	Cascade
M2	81	Start Mod. Delay Fact.	Defines the time in minutes from the moment the demand is triggered until the activation of the setpoint increases or decreases provided for by Par. 79 e 80	0...60	60	Min.	I	Cascade
M2	82	Next Module Start Rate	It defines the minimum power for at least one of the modules in the cascade in order for the next module to be switched on (if the other conditions linked to Par. 75 and 77 are met)	10...100	80	%	I	Cascade
M2	83	Next Module Stop Rate	It defines the maximum power for all the modules in the cascade in order for the last module on to be switched off (if the other conditions linked to Par. 76 and 78 are met)	10...100	25	%	I	Cascade
M2	84	Module Rotation Interval	It defines the time interval (in days) after which modules are rotated	0...30	5	Days	I	Cascade
M2	149	First Module to Start	Establishes the number of the next module to be rotated (this value is automatically updated at each rotation)	1...8	1		I	Cascade
M2	86	PID P	Defines the proportional term to change the setpoint of the cascade module	0...1275	50		0	Cascade
M2	87	PID I	Defines the integral term to change the setpoint of the cascade module	0...1275	250		0	Cascade
M2	150	PID Slew Rate Up	Defines the speed (in °C/100 ms) with which the setpoint of individual modules is increased in the event the primary circuit's setpoint is not achieved (if the value is set to zero, the change is controlled by the PI of Par. 86 and 87 without restrictions)	0...25.5	5		0	Cascade
M2	151	PID Slew Rate Dn	Defines the speed (in °C/100 ms) with which the setpoint of individual modules is decreased in the event the primary circuit's setpoint is exceeded (if the value is set to zero, the change is controlled by the PI of Par. 86 and 87 without restrictions)	0...25.5	5		0	Cascade
M2	152	PwrMode2 Min Power	Defines the power value (in percentage terms) against which the average power of all on modules in cascade operation mode must be compared (Par. 148 = 2)	0...100	20	%	I	Cascade

Menu.	Par. No.	Display visualisation	Description	Range	Default setting	UM	Access type	Category
M2	153	PwrMode2 Hysteresis	Defines the extra power value (in percentage terms) compared to the average power of all on modules in cascade operation mode (Par. 148 = 2)	0...100	40	%	I	Cascade
M2	154	Post-Pump period	Defines overrun time in seconds at the end of the cascade heat demand	0...255	30	Sec	I	Cascade
M2	184	N. active burner in DHW	With this setting it is possible to set the number of burners that are used for cascade DHW	0...16	16		I	Cascade
M3	73	Boiler Address	Defines the way in which the boiler is managed	Managing, Stand-alone, Dependent	Stand-alone	.	I	Cascade
M3	156	Permit EmergencyMode	Enable/disable emergency mode	Yes/No	Yes	.	U	Cascade
M3	157	Emergency Setpoint	Defines the emergency mode setpoint	20...90 (68...194)	70 (158)	°C (°F)	I	Cascade
M3	158	Delay Per Start Next Blr.	"reserved"	0...1275	1275	Sec.	I	Cascade
M3	159	Delay Per Stop Next Blr.	"reserved"	0...1275	1275	Sec	I	Cascade
M3	160	Delay Quick Start Next	"reserved"	0...1275	400	Sec	I	Cascade
M3	161	Delay Quick Stop Next	"reserved"	0...1275	240	Sec	I	Cascade
M3	162	Hyst Down Start Boiler	"reserved"	0...40 (32...104)	5 (9)	°C (°F)	I	Cascade
M3	163	Hyst Up Stop Boiler	"reserved"	0...40 (32...104)	2 (3.6)	°C (°F)	I	Cascade
M3	164	Hyst Down Quick Start	"reserved"	0...40 (32...104)	10 (18)	°C (°F)	I	Cascade
M3	165	Hyst Up Quick Stop	"reserved"	0...40 (32...104)	4 (7.2)	°C (°F)	I	Cascade
M3	166	Hyst Up Stop All	"reserved"	0...60 (32...140)	8 (14.4)	°C (°F)	I	Cascade
M3	167	Number of boilers	"reserved"	1...16 (basic cascade) 1...8 (full cascade)	1		I	Cascade
M3	168	Power Mode	"reserved"	0) Disabled 1) Min burners 2) Max burners 3) Balanced burners	2		I	Cascade
M3	169	Max. Setp. Offset Down	Defines the maximum decrease in the primary circuit's cascade setpoint. Is based on the secondary circuit's probe reading	0...40 (32...104)	8 (14.4)	°C (°F)	I	Cascade
M3	170	Max Setp Offset Up	Defines the maximum increase in the primary circuit's cascade setpoint. Is based on the secondary circuit's probe reading	0...40 (32...104)	8 (14.4)	°C (°F)	I	Cascade
M3	171	Start Mod. Delay Fact.	Defines the time in minutes from the moment the request is triggered until the activation of the setpoint increases or decreases provided for by Par.169 e 170	0...255	20	Min.	I	Cascade
M3	172	Next Boiler Start Rate	"reserved"	10...100	80	%	I	Cascade
M3	173	Next Boiler Stop Rate	"reserved"	10...100	25	%	I	Cascade
M3	174	Boiler Rotation Interval	"reserved"	0...30	5	Days	I	Cascade
M3	175	First Boiler to Start	"reserved"	1...8	1		I	Cascade
M3	176	PID P	Defines the proportional term to change the setpoint of the cascade module based on the secondary circuit's temperature	0...1275	25		0	Cascade

Menu.	Par. No.	Display visualisation	Description	Range	Default setting	UM	Access type	Category
M3	177	PID I	Defines the integral term to change the setpoint of the cascade module based on the secondary circuit's temperature	0...1275	500		0	Cascade
M3	178	PID Slew Rate Up	Defines the speed (in °C/100 ms) with which the setpoint of individual modules is increased in the event the secondary circuit's setpoint not reached (if the value is set to zero, the change is controlled by the PI of Par. 176 and 177 without restrictions)	0...25.5	5		0	Cascade
M3	179	PID Slew Rate Dn	Defines the speed (in °C/100 ms) with which the setpoint of individual modules is decreased in the event the primary circuit's setpoint is exceeded (if the value is set to zero, the change is controlled by the PI of Par. 176 and 177 without restrictions)	0...25.5	5		0	Cascade
M3	180	PwrMode2 Min Power	"reserved"	0...100	20		I	Cascade
M3	181	PwrMode2 Min Hysteresis	"reserved"	0...100	40		I	Cascade
M3	182	Post-Pump period	"reserved"	0...255	30		I	Cascade
M4		Appliance model	Defines the boiler model	1...4	3		0	General
M4	97	I/O Configuration	Supports uploading the values of Par. from 116 to 128 from a set of pre-defined rpm values that defines the configuration of the boiler's inputs and outputs	1...53	12		I	General
M4	98	Appliance settings	Supports uploading the values of Par. 92, 93 and 94 from a set of pre-defined rpm values that identifies the boiler type	1...85	17		I	General

APPENDIX J – TROUBLESHOOTING TABLE

LOCKOUT CODES

Error no.	Error	Description	Checks	Solutions
0	E2PROM_READ_ERROR	Internal software error		Control board replacement
1	IGNIT_ERROR	Three unsuccessful ignition attempts in a row	a- Check gas supply pressure; b- Check spark and ignitor rod. c- Correct amount of air; d-Check for 120VAC at the gas valve. e- Ensure that the gas valve is functioning properly by checking for changes in gas pressure.	a- If the gas supply pressure is incorrect, it must be adjusted to the correct pressure; b- If spark is not present check for correct ignition electrode position; c- If the combustion air pressure is incorrect, inspect the vent system and eliminate any obstructions; d- If the voltage to the gas valve is not 120Vac the power control board must be replaced.
2	GV_RELAY_ERROR	Failure detected in the GV (Gas Valve) relay	a- Check the integrity of the wire connections between gas valve and control board.	a- If wires are damaged, replace them b- If wires are ok, replace the gas valve or the power control board.
3	SAFETY_RELAY_ERROR	Internal control board error		a- If the error occurs during boiler normal operation, replace the Control board b- If the error occurs at the electrical switching on (by main switch) of the boiler, check high sensor limit (and its wiring) integrity
4	BLOCKING_TOO_LONG	Control had a blocking error for more than 20 hours. This error is caused when any Blocking errors occur and are not corrected automatically. Therefore it causes a Locking error.	a- Press RESET button to display the Blocking error description b- Check error log on touch-screen. c- The blocking error that occurred previous to current locking error will be the cause (i.e.- 163 LowExFlow).	Remove the cause of the Blocking error
5	FAN_ERROR_NOT_RUNNING	Fan is not running after 60 seconds.	a- Check for 120 VAC power connection of the fan. b- Check PWM connection of the fan.	a- If no 120 VAC voltage is present, replace the power control board; b- If no PWM signal is present, replace power control board; c- Replace the fan.
6	FAN_ERROR_TOO_SLOW	Fan runs too slow for more than 60 seconds		
7	FAN_ERROR_TOO_FAST	Fan runs too fast for more than 60 seconds		
8	RAM_ERROR	Internal software error		Control board replacement
9	WRONG_EEPROM_SIGNATURE	Contents of E2PROM are not up to date		Control board replacement
10	E2PROM_ERROR	Wrong safety parameters in E2PROM		Control board replacement
11	STATE_ERROR	Internal software error		Control board replacement
12	ROM_ERROR	Internal software error		Control board replacement
13	APS_NOT_OPEN	Air pressure switch not working		
14	APS_NOT_CLOSED	Air pressure switch not working		
15	MAX_TEMP_ERROR	The external overheat protection is enabled or the High limit sensor measures a temperature of over 95°C (203°F)	a- Check module water temp. b- Check the pump to verify the flow circulation; c- Check if the valves on hydraulic circuit are open; d- Check the high limit switch.	a- Change the pump or restart it; b- Open the valves on hydraulic circuit; c- Change the high limit switch.
16	FLUE_GAS_ERROR	Flue temperature exceeded the maximum allowable flue temperature		

Error no.	Error	Description	Checks	Solutions
17	STACK_ERROR	Internal software error		Control board replacement
18	INSTRUCTION_ERROR	Internal software error		Control board replacement
19	ION_CHECK_FAILED	Internal software error		Control board replacement
20	FLAME_OUT_TOO_LATE	Flame still present 10 seconds after closing the gas valve		Replace the gas valve
21	FLAME_BEFORE_IGNIT	Flame is detected before ignition		Replace the gas valve
22	TOO_MANY_FLAME_LOSS	Three flame failures during one demand cycle	a- Check the integrity of the wire connections of the spark and the earth on heat exchanger b- check ionization signal while running	a- If wires are damaged, replace them b- check for proper combustion settings - if correct replace spark/flamerod.
23	CORRUPTED_ERROR_NR	Error code RAM byte was corrupted to an unknown error code		
24	FLUE_SWITCH_NOT_CLOSING	The blocked flue sensor is not closed within 10 minutes		
29	PSM_ERROR	Internal software error		
30	REGISTER_ERROR	Internal software error		Control board replacement
33	LWCO_1_ERROR	Low Water Cut-Off 1 error	a- Check to ensure all valves are open, pump is running. b- Check the wiring between the controller and the LWCO probe.	a- Verify water is in the boiler. b- Verify good connection between control module and low water probe.
34	LWCO_2_ERROR	Low Water Cut-Off 2 error	a- Check to ensure all valves are open, pump is running. b- Check the wiring between the controller and the LWCO probe.	a- Verify water is in the boiler. b- Verify good connection between control module and low water probe.
35	GAS_PRESSURE_ERROR	Gas pressure switch is closed. This can either be the High or Low Gas Pressure Switch.	a- Check gas pressure to ensure it is steady and within the recommended range for the unit. b- Check with as many modules on as possible to ensure supply connections are sized properly.	
36	AIR_DAMPER_LOCKING	Air Damper feedback is not received when the relative output is open for the fourth time.		
37	FLUE_PRESSURE_LOCKING	Flue pressure switch is closed for the fourth time.	a- Check for obstruction in the flue piping. b- Blocking errors should be recorded prior to the occurrence of this Locking error. c- Check for condensate in the hose connecting the flue pressure switch to ensure it isn't blocked.	

BLOCKING ERRORS

Error no.	Error	Description	Checks	Solutions
100	WD_ERROR_RAM	Internal software error		Control board replacement
101	WD_ERROR_ROM	Internal software error		Control board replacement
102	WD_ERROR_STACK	Internal software error		Control board replacement
103	WD_ERROR_REGISTER	Internal software error		Control board replacement
104	HIGH_LIMIT_FAIL	Physical high limit test failed		Control board replacement
106	REFHI_TOO_HIGH	Internal software error		Control board replacement

Error no.	Error	Description	Checks	Solutions
107	REFHI_TOO_LOW	Internal software error		Control board replacement
108	REFLO_TOO_HIGH	Internal software error		Control board replacement
109	REFLO_TOO_LOW	Internal software error		Control board replacement
110	REFHI2_TOO_HIGH	Internal software error		Control board replacement
111	REFHI2_TOO_LOW	Internal software error		Control board replacement
112	REFLO2_TOO_HIGH	Internal software error		Control board replacement
113	REFLO2_TOO_LOW	Internal software error		Control board replacement
114	FALSE_FLAME	Flame is detected in a state in which no flame is allowed to be seen		Control board replacement
115	LOW_WATER_PRESSURE_ERROR	Low water pressure error	a- Check system water pressure. b- Ensure that it is above min. recommended pressure (7.5PSI). c- Check the value of the reading of this sensor in the info screen. If the value is not in line with the system pressure check the sensor.	
116	LOW_WATER_PRESSURE_SENSOR	Low water pressure		
117	BLOCKED_DRAIN	Blocked drain switch is active		
118	WD_COMM_ERROR	Watchdog communication error		Control board replacement
119	RETURN_OPEN	Return sensor open	a- Check the integrity of the wire connections; b- Check the return temperature sensor.	a- If the wiring is damaged, replace it; b- Verify that the temperature sensor has the correct resistance values. If values are incorrect sensor must be replaced.
120	SUPPLY_OPEN	Supply sensor open	a- Check the integrity of the wire connections; b- Check the supply temperature sensor.	a- If the wiring is damaged, replace it; b- Verify that the temperature sensor has the correct resistance values. If values are incorrect sensor must be replaced.
122	DHW_OPEN	DHW sensor open	a- Check the integrity of the wire connections; b- Check the DHW temperature sensor.	a- If the wiring is damaged, replace it; b- Verify that the temperature sensor has the correct resistance values. If values are incorrect sensor must be replaced.
123	FLUE_OPEN	Flue sensor open		
125	OUTDOOR_OPEN	Outdoor sensor open	a- Check the integrity of the wire connections; b- Check the Outdoor temperature sensor.	a- If the wiring is damaged, replace it; b- Verify that the temperature sensor has the correct resistance values. If values are incorrect sensor must be replaced.
126	RETURN_SHORTED	Return sensor shorted	a- Check the integrity of the wire connections; b- Check the return temperature sensor.	a- If the wiring is damaged, replace it; b- Verify that the temperature sensor has the correct resistance values. If values are incorrect sensor must be replaced.
127	SUPPLY_SHORTED	Supply sensor shorted	a- Check the integrity of the wire connections; b- Check the supply temperature sensor.	a- If the wiring is damaged, replace it; b- Verify that the temperature sensor has the correct resistance values. If values are incorrect sensor must be replaced.

Error no.	Error	Description	Checks	Solutions
129	DHW_SHORTED	DHW sensor shorted	a- Check the integrity of the wire connections; b- Check the DHW temperature sensor.	a- If the wiring is damaged, replace it; b- Verify that the temperature sensor has the correct resistance values. If values are incorrect sensor must be replaced.
130	FLUE_SHORTED	Flue sensor shorted	a- Check the integrity of the wire connections; b- Check the Outdoor temperature sensor.	a- If the wiring is damaged, replace it; b- Verify that the temperature sensor has the correct resistance values. If values are incorrect sensor must be replaced.
132	OUTDOOR_SHORTED	Outdoor sensor shorted	a- Check the integrity of the wire connections; b- Check the Outdoor temperature sensor.	a- If the wiring is damaged, replace it; b- Verify that the temperature sensor has the correct resistance values. If values are incorrect sensor must be replaced.
133	RESET_BUTTON_ERROR	Too many resets in a short time period		
135	T_EXCHANGE_BLOCK_ERROR	Exchange temperature exceeded 90°C		
141	T_SELECTION3_OPEN	Selection 3 sensor open		
142	T_OPTIONAL1_OPEN	Optional 1 sensor open		
143	T_OPTIONAL2_OPEN	Optional 2 sensor open		
144	T_AMBIENT_OPEN	Ambient sensor open		
145	T_CHIMNEY_CLOSED	Chimney sensor shorted		
155	FLUE_PRESSURE_ERROR	Flue pressure switch is open	a- Check flue for obstructions. Clear if found. b- Check flue pressure to ensure flue has been installed and sized properly. c- Flue pressure switch default to 2.2"wc.	a- Remove any obstructions from the exhaust system; b- Remove any obstruction from condensate discharge and confirm the condensate can flow freely.
156	AIR_DAMPER_ERROR	Air Damper feedback is not received when the relative output is closed		
162	FLUE_BLOCKED	Flue is blocked, demand needs to be stopped with fan at ignition speed, but no error needed to be stored at this time		
163	LOWEXFLOW_PROTECTION	Flow is too low, demand needs to be stopped with fan at ignition speed, but no error needed to be stored at this time	a- Flow through the module is below recommended rate. b- Check to ensure module pump is running. c- Verify valves are open. d- Possible air entrapment.	

WARNINGS

Error no.	Error	Description	Checks	Solutions
200	CC_LOSS_COMMUNICATION	Cascade System: Leading burner lost communication with one of the depending burners	a- Check wiring and connections on individual Modules. b- Make sure both controllers in the boiler are powered on. c- Make sure Parameter 147 set to 2. d- Check the position of the S1 switches on the dependent module to make sure it is off.	

Error no.	Error	Description	Checks	Solutions
201	CC_LOSS_BOILER_COMM	Cascade System: Leading boiler lost communication with one of the depending boilers	a- Check interconnecting wiring between boilers. b- Make sure all boilers are powered on. c- Make sure that Parameter 167 set to proper number of boilers. d- Whichever boiler(s) loses communication with the Master Boiler will enter boiler level emergency mode. e- Check the position of the S1 switches on the managing boiler (on) and on the dependent boiler (off) to make sure they are set properly.	
202	OUTDOOR_WRONG	Outdoor sensor is open or shorted		
203	T_SYSTEM_WRONG	T_System sensor is open or shorted	a- Check connections of the boiler mounted sensor. b- This will cause Module Emergency Mode to activate on that particular boiler. c- Remaining cascade will continue to operate as normal. d- Check the value of the reading of this sensor on the info screen.	
204	T_CASCADE_WRONG	T_Cascade sensor is open or shorted	a- Check connections of the System sensor mounted in the header. b- This will cause Boiler level emergency mode to activate on all boilers in the cascade. c- Check the value of the reading of this sensor on the info screen.	
205	HIGH_LIMIT_TEST_WAIT_ACTIVE	Too many physical high limit test attempts within 24 hours.		
206	DHW sensor is open or shorted	Current setpoint is higher than 176°F (80°C)		
207	DHW_SENSOR_WRONG	DHW sensor is open or shorted		
208	ZONE_SENSOR_WRONG	Zone sensor is open or shorted		
209	BOILER_DEMAND-DISABLED	All incoming demand is disabled		

APPENDIX K – CONNECTION DIAGRAM

CONNECTION DIAGRAM 905PB DISPLAY

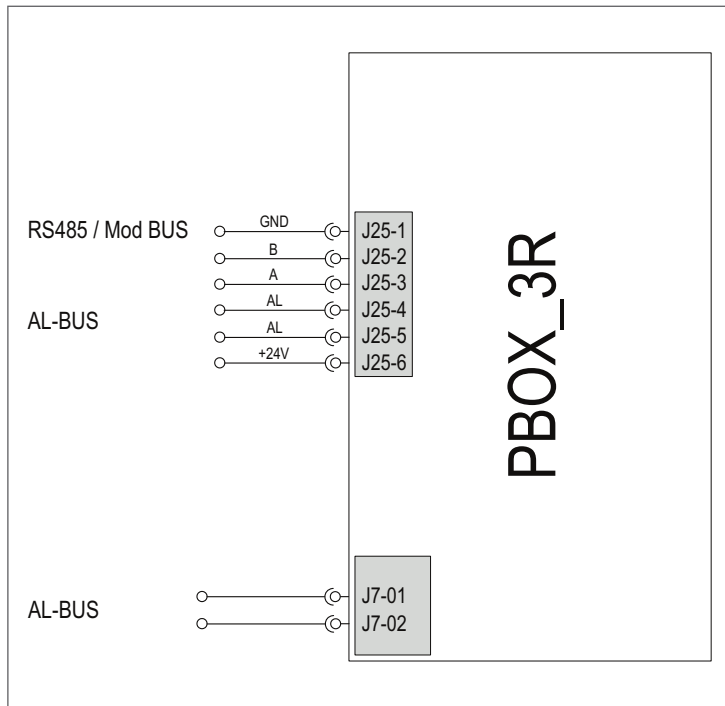

905PB05_3R	
Connector	Function
J7	PC interface
J25	Connection to MN control/Modbus

905PB05_3R Display: RJ-11 Connector:

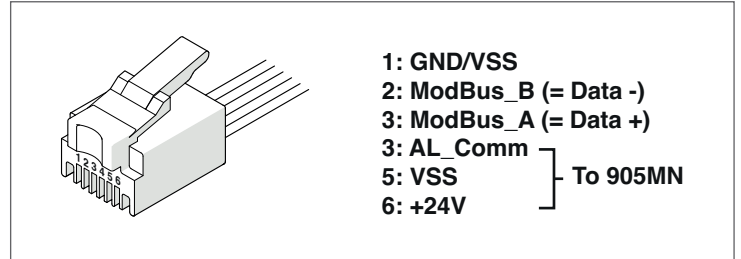

J25 Wire Colors:

- J25-1: Grey
- J25-2: Black
- J25-3: Green
- J25-4: Yellow
- J25-5: Red
- J25-6: Blue

CONNECTION DIAGRAM 905TS (Touchscreen) AND 905PB DISPLAY

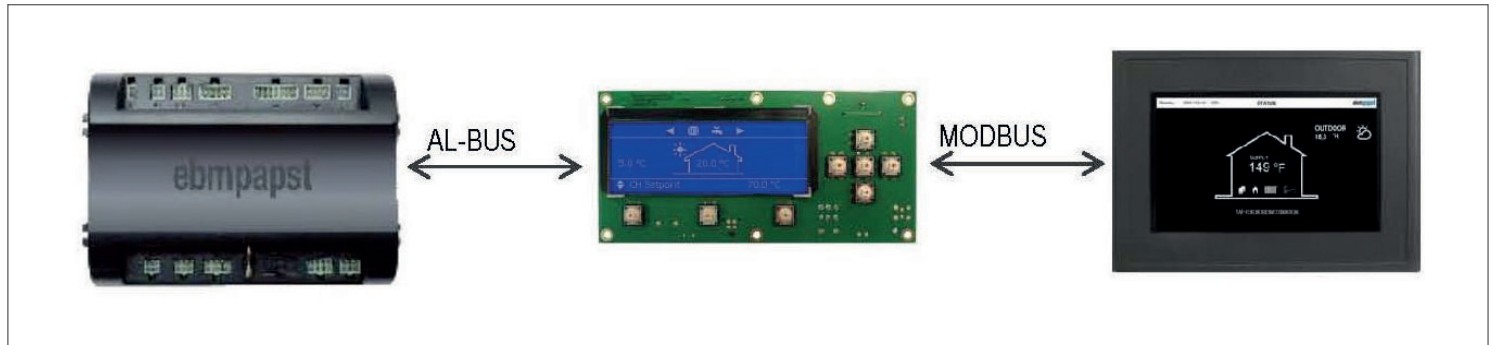

Modbus connection diagram between the 900PB and TS

Pins on connector COM1 of the TS:

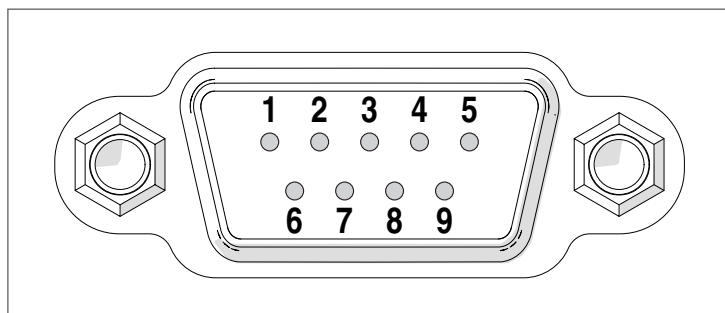

Primary connection to 900PB:

Communication	Pin	Function	Connect to
COM2 (Master)	2	RS 485 +	900 PB (J25-1)
	1	RS 485 -	900 PB (J25-4)

Secondary connection to BMS (pre-wired):

Communication	Pin	Function
COM1 (Slave)	7 br	RS485 +
	8 bl	RS485 -
	9 bk	GND

APPENDIX L – TS ADDRESS

STATUS INFO

All the register number are referred for a Zero-based Modbus device, if the device use one-based all the register must be scroll up for 1 number (502 Setpoint will be 503)

TS address	Access		Description	Factor	Range
	R	W			
System status info					
5100	R		State	1	State (*)
5101	R		Status	1	The same as State
5102	R		Error code	1	See error list
5103	R		CH setpoint	10	4.0–90.0°C (1)
5104	R		DHW setpoint	10	40.0–71.0°C (1)
5110	R		CH pump	1	0=Off, 1=On
5111	R		DHW pump	1	0=Off, 1=On
5112	R		General pump	1	0=Off, 1=On
5121	R		Return temperature	10	–40.0–150.0°C
5122	R		DHW temperature	10	–40.0–150.0°C
5123	R		Flue temperature	10	–40.0–150.0°C
5124	R		System temperature	10	–40.0–150.0°C
5125	R		Outdoor temperature	10	–40.0–150.0°C
5140	R		Firing rate (power output)	1	0..100%
5142	R		Flame (ionization) current	10	0.0–xx.x µA
5143	R		Water pressure	10	0.0–x.x Bar

(*) The State can be divided in the following steps:

Standby	0: Initialization	1: Reset	2: Standby		
Active	3/4: Pre purge	5/6: (Pre) Ignition	7: Flame providing	8/9: Burn	10/11: Post purge
Error	12: Error	13: Alarm	14: Warning	15: Burner Boot	

Note 1: This setting is only possible in steps of 0.5 degrees

HYSTORY INFO

TS address	Access		Description	Factor	Range
	R	W			
System status info					
5200	R		Ignit success	1/16	0..65534
5201	R		Ignit failed	1	0..65534
5202	R		Flame failed	1	0..65534
5203	R		Burn hours CH	1	0..65534 hours
5204	R		Burn hours DHW	1	0..65534 hours
5220..5235	R		Lockout history (#5220..5235)	1	See error list
5236..5251	R		Lockout time (#5236..5251)	1	0..xxx hours
5260..5275	R		Blocking history (#5260..5275)	1	See error list
5276..5291	R		Blocking time (#5276..5291)	1	0..xxx hours

DEPENDENT INFORMATION

TS address	Access		Description	Factor	Range
	R	W			
Dependent 01					
5300	R		State	1	State (*)
5302	R		Error Code	1	See error list
5303	R		Firing Rate (power output)	1	0...100%
Dependent 02					
5306	R		State	1	State (*)
5308	R		Error Code	1	See error list
5309	R		Firing Rate (power output)	1	0...100%
Dependent 03					
5312	R		State	1	State (*)
5314	R		Error Code	1	See error list
5315	R		Firing Rate (power output)	1	0...100%
Dependent 04					
5318	R		State	1	State (*)
5320	R		Error Code	1	See error list
5321	R		Firing Rate (power output)	1	0...100%
Dependent 05					
5324	R		State	1	State (*)
5326	R		Error Code	1	See error list
5327	R		Firing Rate (power output)	1	0...100%
Dependent 06					
5330	R		State	1	State (*)
5332	R		Error Code	1	See error list
5333	R		Firing Rate (power output)	1	0...100%
Dependent 07					
5336	R		State	1	State (*)
5338	R		Error Code	1	See error list
5339	R		Firing Rate (power output)	1	0...100%
Dependent 08					
5342	R		State	1	State (*)
5344	R		Error Code	1	See error list
5345	R		Firing Rate (power output)	1	0...100%
Dependent 09					
5348	R		State	1	State (*)
5350	R		Error Code	1	See error list
5351	R		Firing Rate (power output)	1	0...100%
Dependent 10					
5354	R		State	1	State (*)
5356	R		Error Code	1	See error list
5357	R		Firing Rate (power output)	1	0...100%
Dependent 11					
5360	R		State	1	State (*)
5362	R		Error Code	1	See error list
5363	R		Firing Rate (power output)	1	0...100%
Dependent 12					
5366	R		State	1	State (*)
5368	R		Error Code	1	See error list
5369	R		Firing Rate (power output)	1	0...100%
Dependent 13					
5372	R		State	1	State (*)
5374	R		Error Code	1	See error list
5375	R		Firing Rate (power output)	1	0...100%
Dependent 14					
5378	R		State	1	State (*)
5380	R		Error Code	1	See error list
5381	R		Firing Rate (power output)	1	0...100%
Dependent 15					
5384	R		State	1	State (*)
5386	R		Error Code	1	See error list
5387	R		Firing Rate (power output)	1	0...100%

(*) The State can be divided in the following steps:

Standby	0: Initialization	1: Reset	2: Standby		
Acrive	3/4: Pre purge	5/6: (Pre) Ignition	7: Flame providing	8/9: Burn	10/11: Post purge
Error	12: Error	13: Alarm	14: Warning	15: Burner Boot	

SETTINGS / PARAMETERS

TS address	Access		Description	Factor	Range
	R	W			
System status info					
500	R	W	CH mode	1	0..5
501	R	W	DHW mode	1	0..8
482	R	W	CH setpoint	10	4.0-90.0°C (1)
503	R	W	DHW setpoint	10	40.0-71.0°C (1)
504	R	W	Reset Curve Boiler Design	10	4.0-90.0°C (1)
505	R	W	Reset Curve Boiler Mild Weather	10	4.0-90.0°C (1)
506	R	W	Reset Curve Outdoor Mild Weather	10	0.0-30.0°C (1)
507	R	W	Reset Curve Outdoor Design	10	-25.0-25.0°C (1)
508	R	W	Warm Weather Shutdown	10	0.0-35.0°C (1)
509	R	W	Reset Curve Boiler Maximum	10	27.0-90.0°C (1)
510	R	W	Reset Curve Boiler Minimum	10	4.0-82.0°C (1)
511	R	W	Night Setback	10	0.0-30.0°C (1)
512	R		Store supply extra	1	15..30
520	R	W	CH enable	1	0=0ff, 1=0n
521	R	W	DHW enable	1	0=0ff, 1=0n
522	R	W	Boiler enable	1	0=0ff, 1=0n
523	R	W	Boiler enable confirm	1	0=0ff, 1=0n
530	R		Basic modbus	1	0 = Extended Modbus 1 = Basic Modbus
531	R		DHW for all	1	0=0ff, 1=0n

Note 1: This setting is only possible in steps of 0.5 degrees

Group	Subgroup	TS Ascon address	Range
Cascade Manager Status	Cascade CH Setpoint	482	Read/Write
	Write Request Activation	481 bit 0	Read/Write
Writing Parameters	Write Request Activation	483 bit 0	Read/Write
	Address Register to Write	484	Read/Write
	Value to Write	486	Read/Write

SERVICE REMINDER

TS address	Access		Description	Factor	Range
	R	W			
Service Reminder Counters					
3300	R		Hours since last service (Burn hours or operation hours, depends on the Service_Hour_Counter setting).	1	0...65534 hours
3301	R		Hours till service is required (Burn hours or operation hours, depends on the Service_Hour_Counter setting).	1	0...Service_Interval
Service Overdue Counters					
3304	R		Overdue counter index	1	0..14
3305	R		Overdue counter 0	1	0...65534 hours
3306	R		Overdue counter 1	1	0...65534 hours
3307	R		Overdue counter 2	1	0...65534 hours
3308..3318	R		Overdue counter 3-13	1	0...65534 hours
3319	R		Overdue counter 14	1	0...65534 hours
Service Settings					
3340	R	W	Reset Service Reminder	1	0...1 (1=Reset)
3341	R	W	Service Hour Counter setting. The counted hours (1500 + 1501) are burn / operation hours.	1	0=Burn hours 1=Operation hours
3342	R	W	Service Interval	1	0...255 x 100 hours

Note: An overdue counter value of 0xFFFF means that the counter is not available/empty

APPENDIX M – FLOWCHARTS

SINGLE MODULE

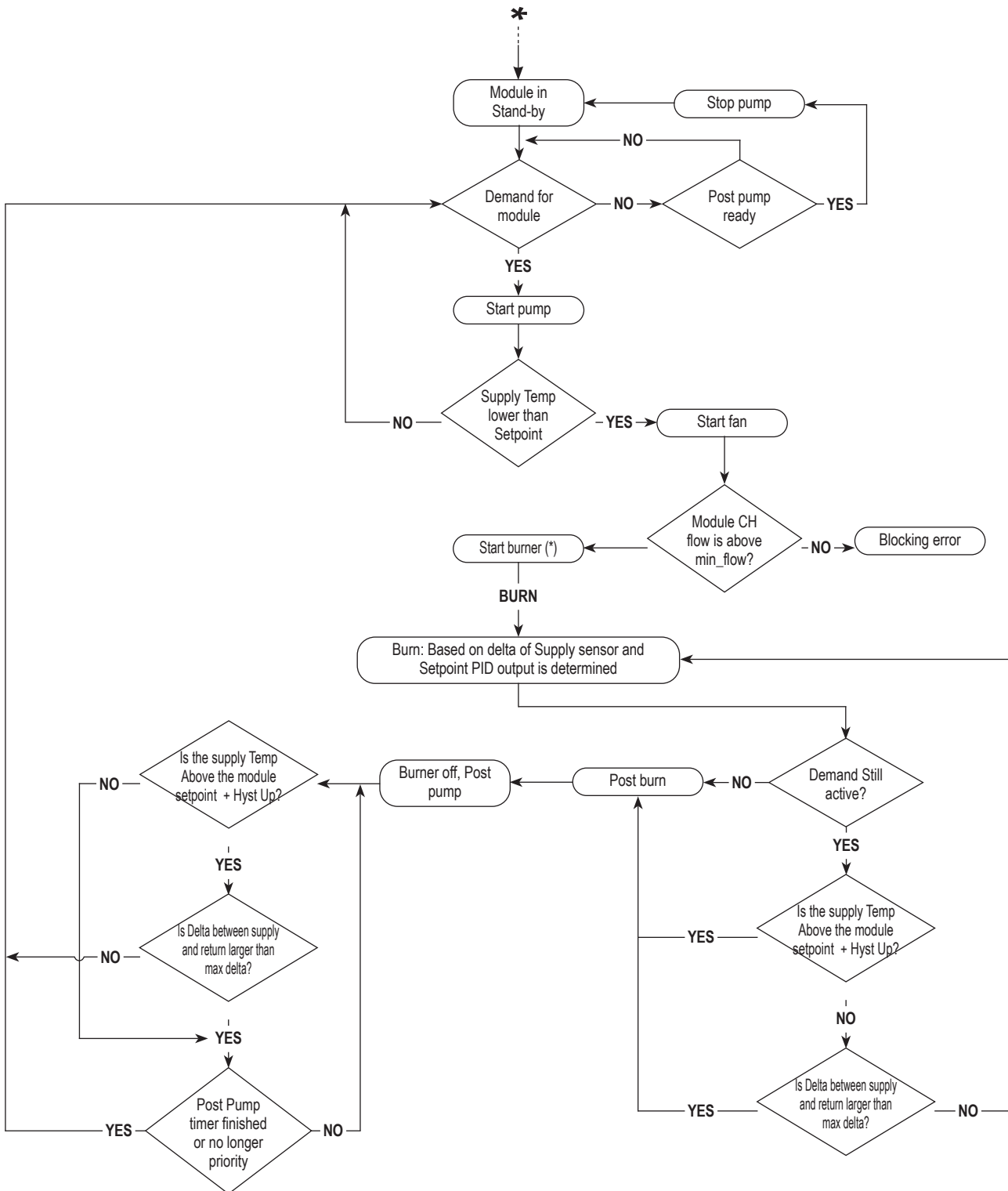

(*) see Burner ignition sequence on next page.

BURNER IGNITION SEQUENCE

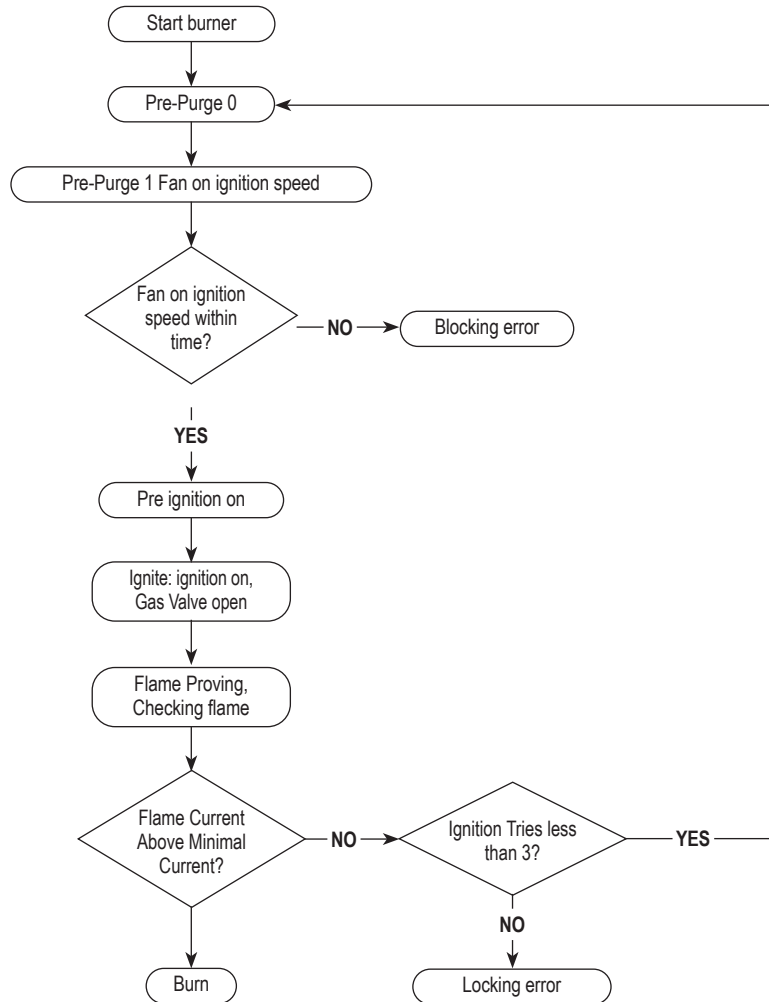

MODULE CASCADE (STAND-ALONE BOILER)

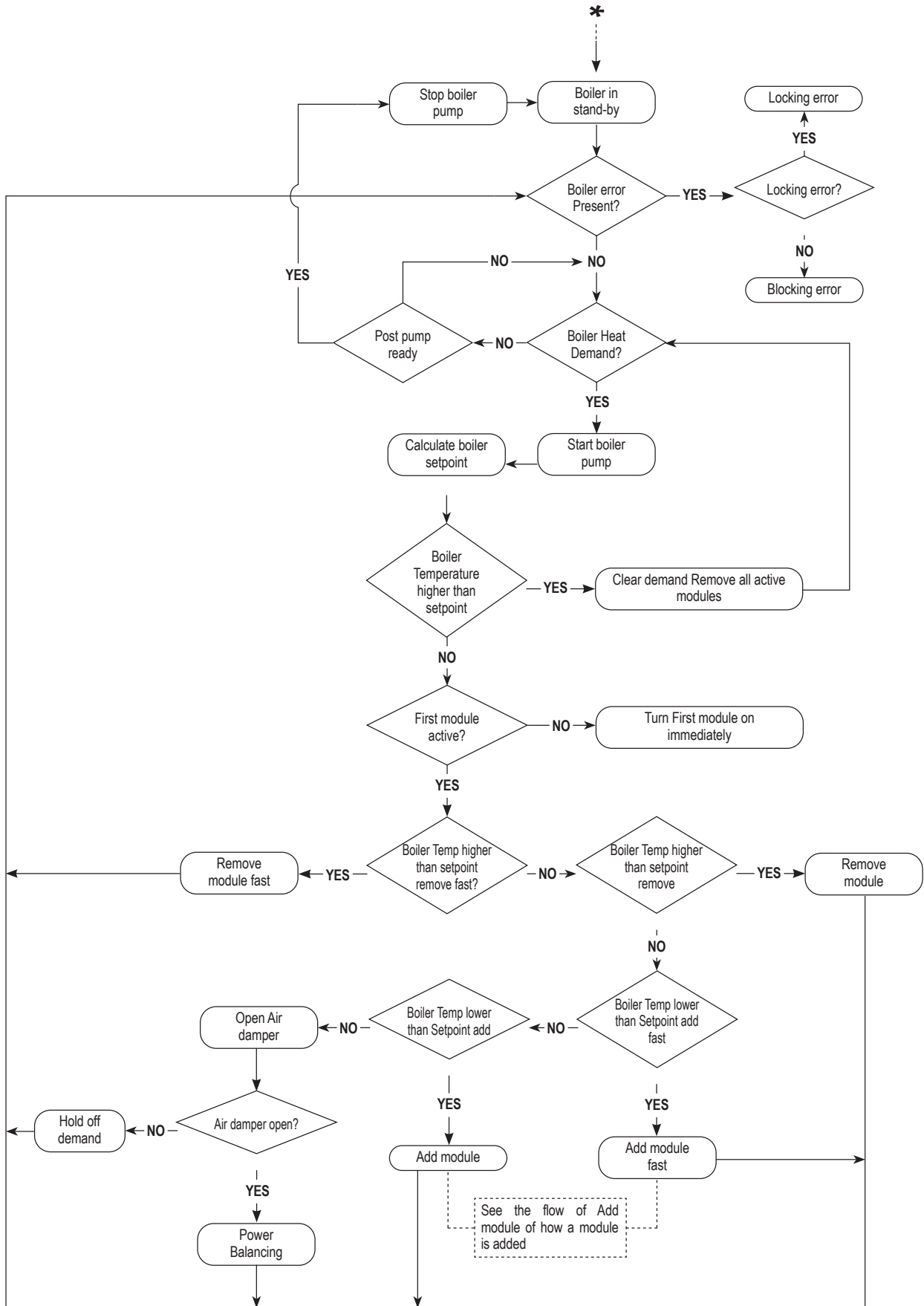

MODULE CASCADE (STAND-ALONE BOILER): ADD/REMOVE MODULE

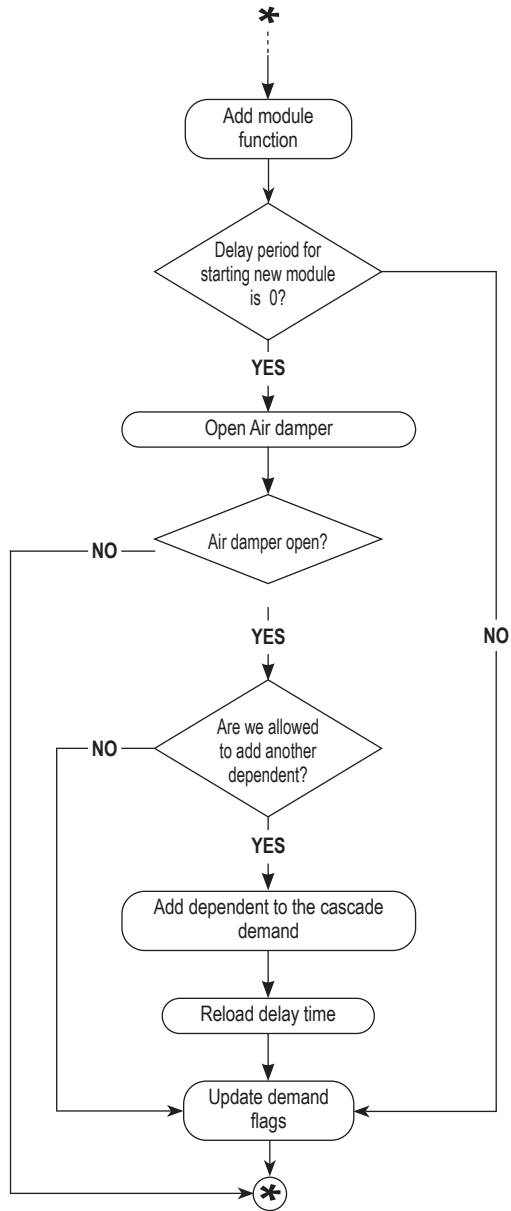

ERROR CHECKING CYCLE

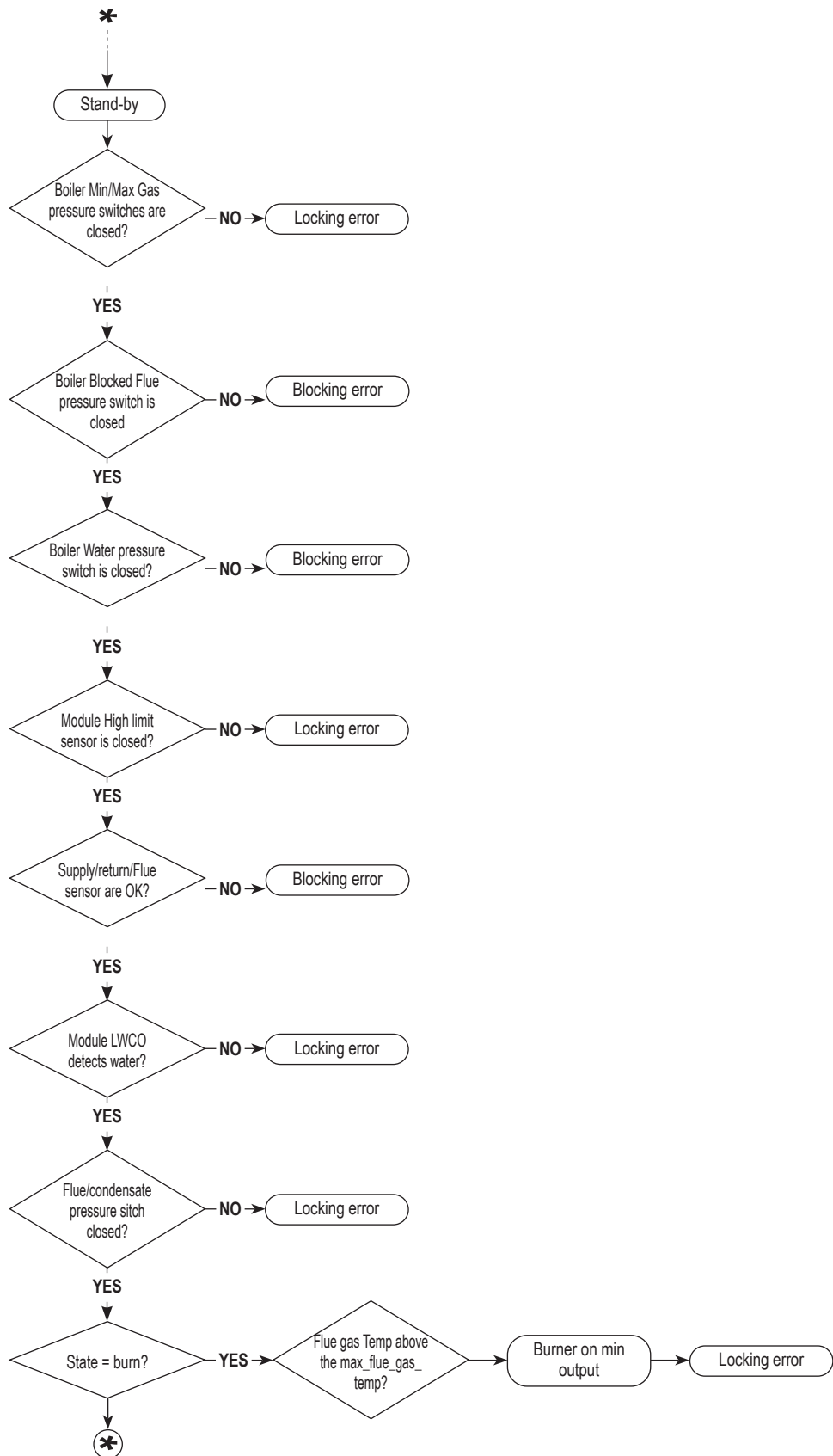

RIELLO

RIELLO S.p.A.
37045 Legnago (VR)
Tel. 0442630111 - Fax 044222378

RIELLO NORTH AMERICA

2165 Meadowpine Blvd
Mississauga, Ontario
Canada L5N 6H6
Tel. (905) 542-0303

www.riello.com/north-america/
www.rielloboilers.com

The manufacturer strives to continuously improve all products. Appearance, dimensions, technical specifications, standard equipment and accessories are therefore subject to change without notice.