

High efficiency commercial heating

11/2020

cod. 27018008 rev. 00



Array AR 3000 – 4000

Stainless Steel Condensing Floor Standing Boilers
Wiring Diagram

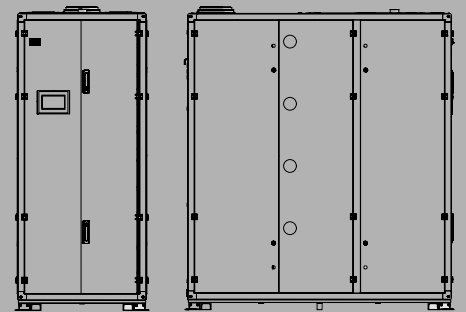

A Carrier Company

RIELLO
Energy For Life

HIGH EFFICIENCY COMMERCIAL HEATING

Stainless Steel Condensing Floor Standing Boilers

WIRING DIAGRAM ARRAY AR 3000, AR 4000

ANNEXE A - SCHÉMA DE CÂBLAGE

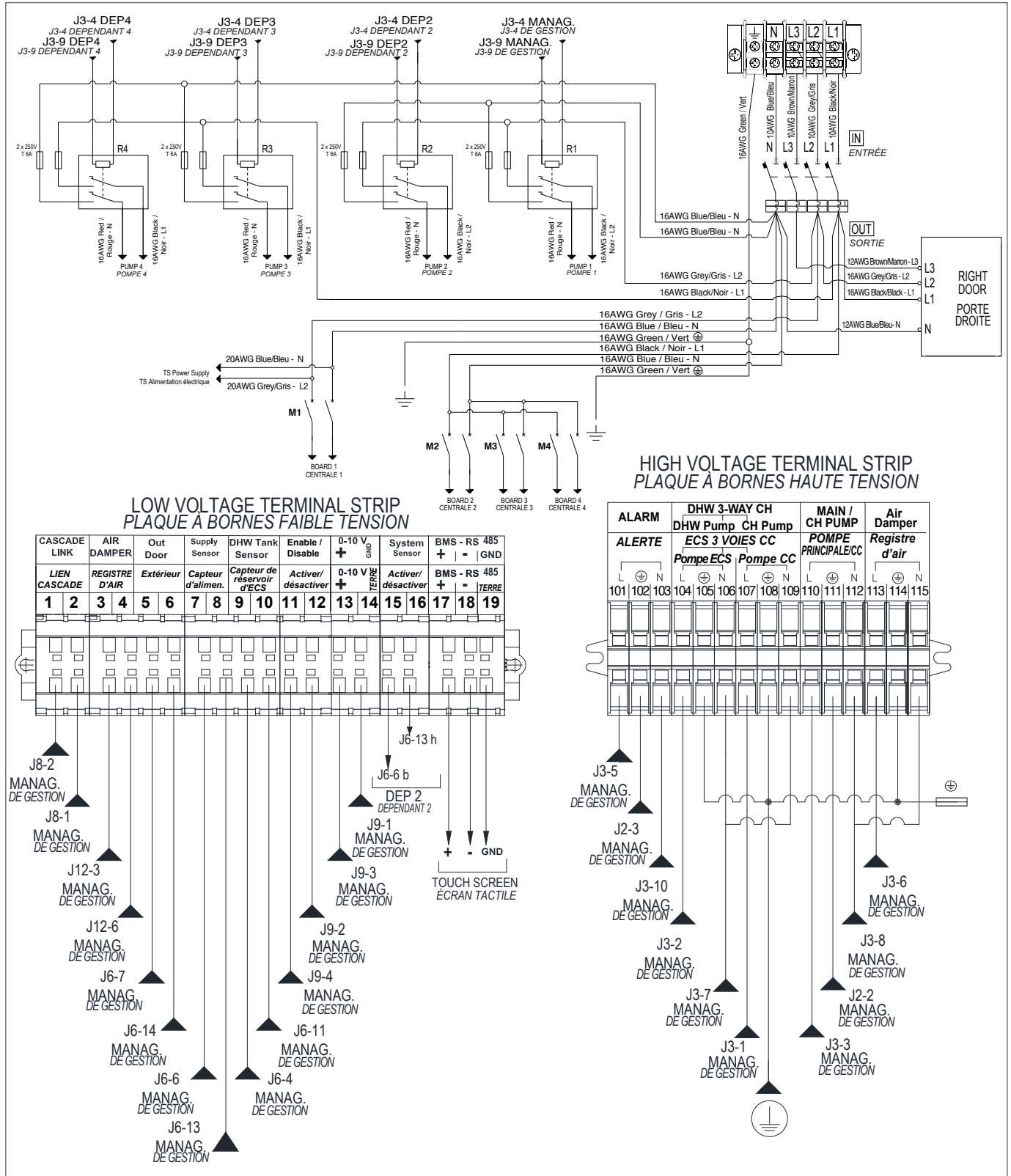

WIRING DIAGRAM ARRAY AR 3000, AR 4000 – MANAGING LEFT DOOR
SCHÉMA DE CÂBLAGE – CHAUDIÈRE DE GESTION – PORTE GAUCHE

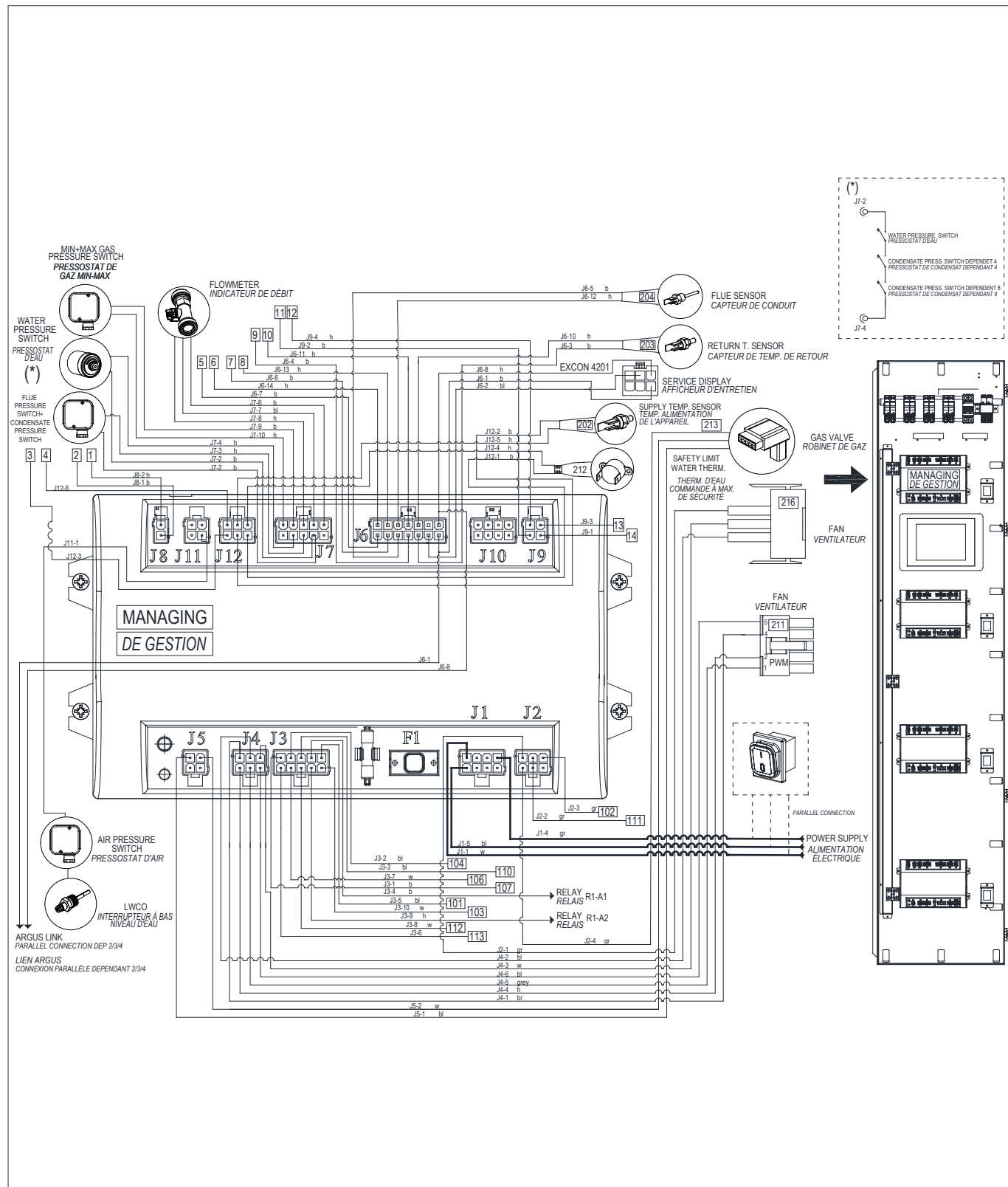

HIGH EFFICIENCY COMMERCIAL HEATING

Stainless Steel Condensing Floor Standing Boilers

WIRING DIAGRAM ARRAY AR 3000, AR 4000 - DEPENDENT 2 / 3 / 4 - LEFT DOOR

SCHÉMA DE CÂBLAGE DE LA CHAUDIÈRE - CHAUDIÈRE DÉPENDANTE 2/3/4 - PORTE GAUCHE

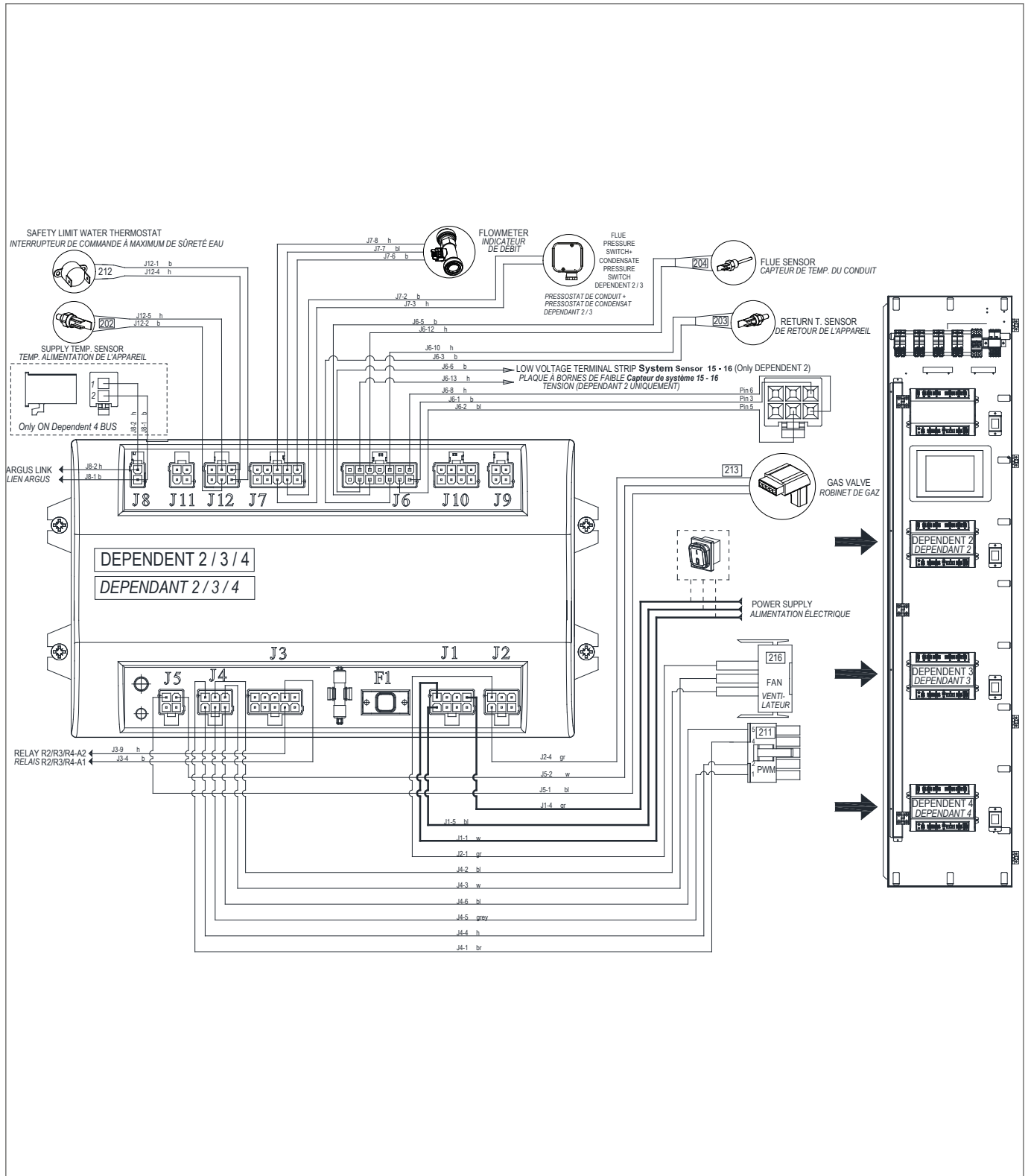

WIRING DIAGRAM ARRAY AR 3000, AR 4000 – RIGHT DOOR
SCHÉMA DE CÂBLAGE – PORTE DROITE

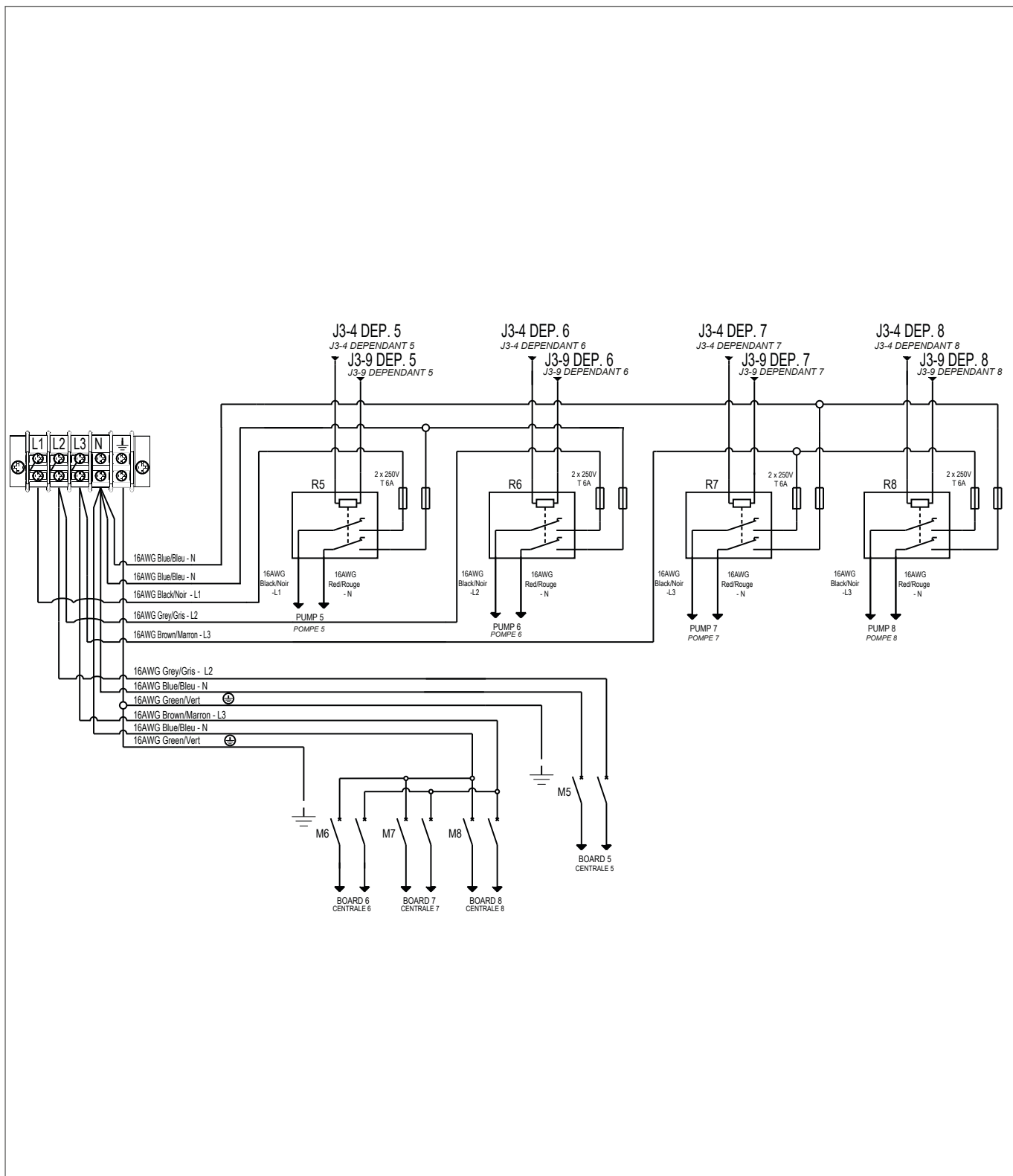

HIGH EFFICIENCY COMMERCIAL HEATING

Stainless Steel Condensing Floor Standing Boilers

WIRING DIAGRAM ARRAY AR 3000, AR 4000 - DEPENDENT 5 / 6 / 7 / 8 - RIGHT DOOR

SCHÉMA DE CÂBLAGE DE LA CHAUDIÈRE - CHAUDIÈRE DÉPENDANTE 5/6/8 - PORTE DROITE

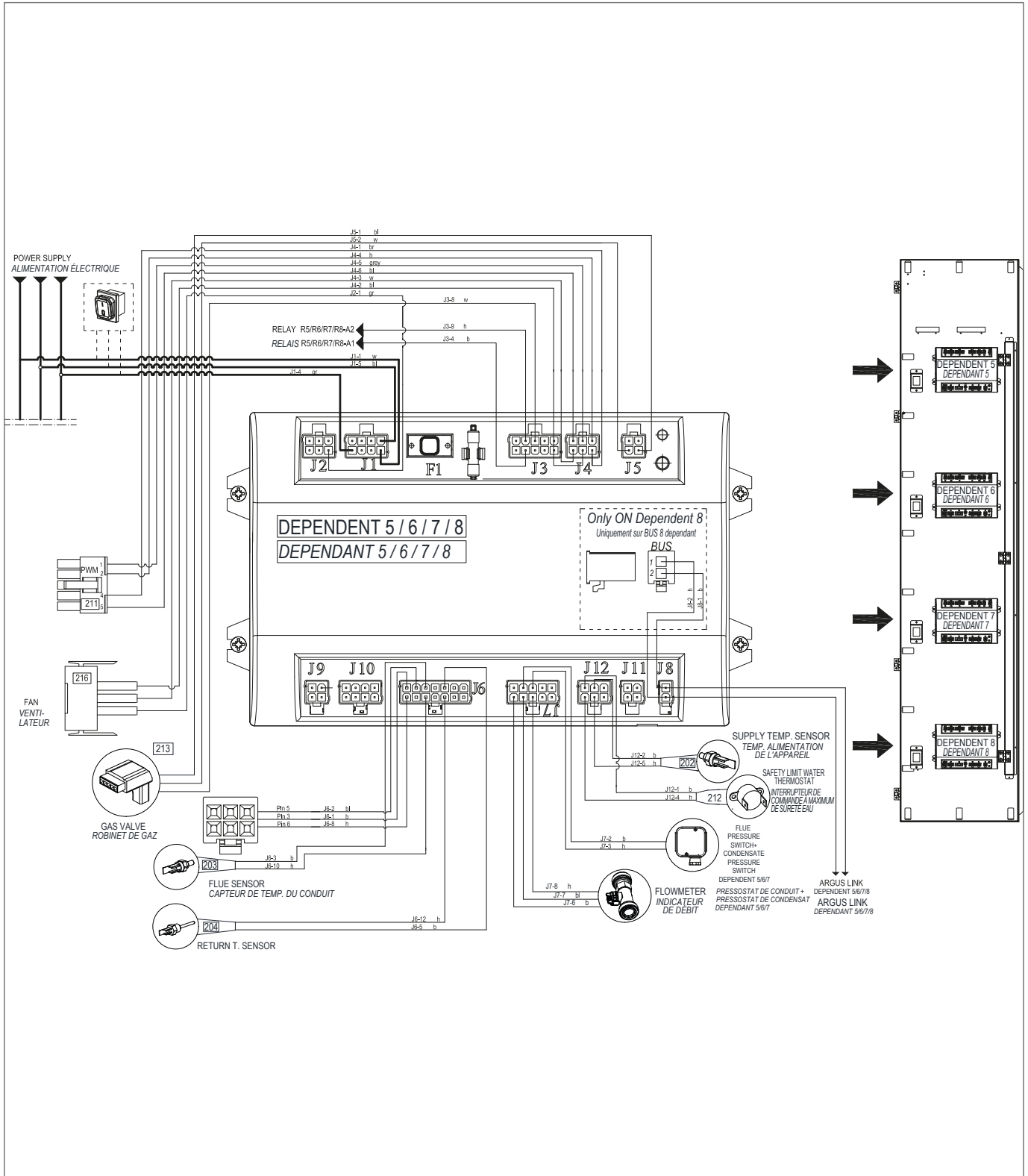

Riello Canada Inc.
2165 Meadowpine Boulevard
Mississauga, Ontario L5N 6H6 (CANADA)
Tel: +1 905 542-0303
Fax: +1 855 878-6599
Toll free: 1-800-474-3556
e-mail: riellonoreply@carrier.com

Riello Corporation of America
35 Pond Park Road
02043 Hingham, Massachusetts (USA)
e-mail: riellonoreply@carrier.com
www.riello.com/north-america

The manufacturer strives to continuously improve all products. Appearance, dimensions, technical specifications, standard equipment and accessories are therefore liable to modification without notice.

RIELLO