

High efficiency commercial heating

01/2021

cod. 27018121 rev. 00



Array SE

Stainless Steel Condensing Floor Standing Boilers
Installation clearances

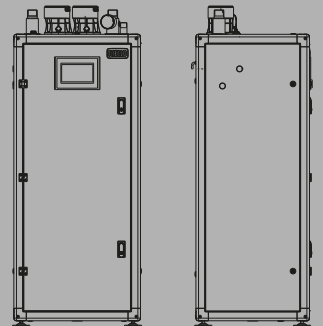

A Carrier Company

RIELLO
Energy For Life

HIGH EFFICIENCY COMMERCIAL HEATING

Stainless Steel Condensing Floor Standing Boilers

INSTALLATION CLEARANCES

The ARRAY model AR 399 SE – AR 500 SE are packaged in an enclosure having identical footprint but different height. The unit must be installed with the prescribed clearances for service. The minimum clearance dimensions, required by Riello, are listed below. However, if Local Building Codes require additional clearances, these codes shall supersede Riello requirements. Recommended minimum clearances for installation and servicing:

- Sides: 10 inches
- Front: 40 inches
- Rear: 5 inches
- Top: 20 inches

The minimum surface of ventilation openings is 3.2 ft² (0.3m²) for gas fuel heating systems.

DÉGAGEMENTS D'INSTALLATION

Les modèle AR 399 SE – AR 500 SE de la chaudière Array est montés dans des enceintes ayant des empreintes au sol identiques mais des hauteurs différentes.

L'appareil doit être installé en respectant les dégagements prescrits pour l'entretien.

Les dimensions de dégagement minimales exigées par Riello sont indiquées ci-dessous.

Cependant, si les codes du bâtiment locaux exigent des dégagements supplémentaires, ces codes supplantent les exigences de Riello.

Les dégagements minimaux recommandés requis sont :

- *Côtés : 10 pouces*
- *Avant : 40 pouces*
- *Arrière : 5 pouces*
- *Dessus : 20 pouces*

La surface minimale des ouvertures de ventilation est de 3.2 ft² (0.3m²) pour les systèmes de chauffage à combustibles gazeux.

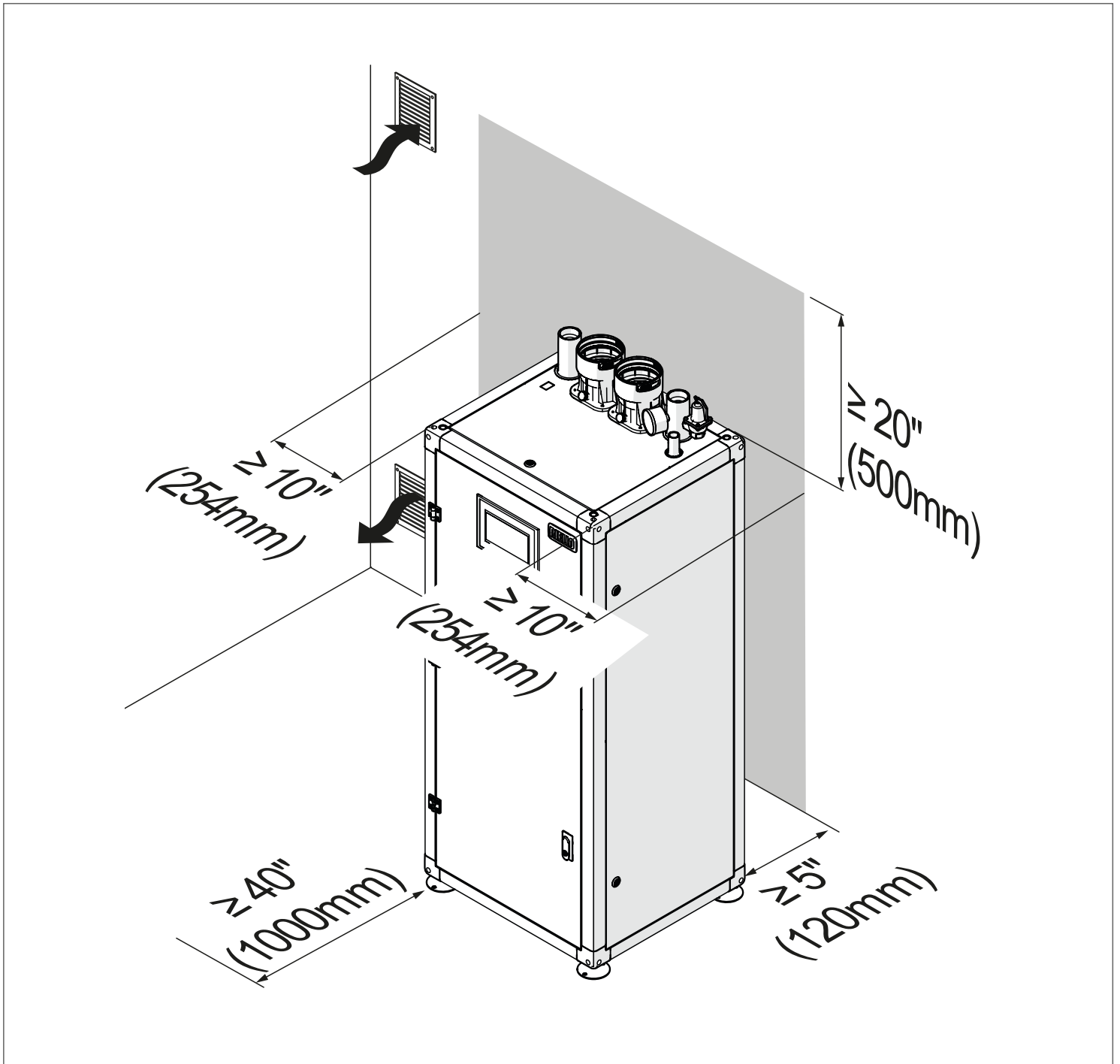

Riello Canada Inc.
2165 Meadowpine Boulevard
Mississauga, Ontario L5N 6H6 (CANADA)
Tel: +1 905 542-0303
Fax: +1 855 878-6599
Toll free: 1-800-474-3556
e-mail: riellonoreply@carrier.com

Riello Corporation of America
35 Pond Park Road
02043 Hingham, Massachusetts (USA)
e-mail: riellonoreply@carrier.com
www.riello.com/north-america

The manufacturer strives to continuously improve all products. Appearance, dimensions, technical specifications, standard equipment and accessories are therefore liable to modification without notice.

RIELLO