

INSIEME EV0e 25 B/70 LN

EN INSTALLATION AND MAINTENANCE MANUAL

RIELLO

Dear heating engineer,
Congratulations on having chosen a **RIELLO** boiler. You have selected a modern, quality product that is designed to give dependable, efficient and safe service and to provide comfort in the home for many years to come.

This manual provides information that is essential to the installation of the appliance. Used in conjunction with your own knowledge and expertise it will enable you to install the appliance quickly, easily, and correctly.

Please accept our thanks and our congratulations on your choice of product.
Riello S.p.A.

RANGE

MODEL	CODE
INSIEME EVOe 25 B/70 LN	20118246

ACCESSORIES

For a complete list of accessories and details of their compatibility, refer to the Catalogue.

CONFORMITY

INSIEME EVOe 25 B/70 LN boilers conform to the following directives:

- Directive 92/42/EEC on efficiency requirements
- Electromagnetic Compatibility Directive 2014/30/EU
- Low Voltage Directive 2014/35/EU
- Ecodesign Directive 2009/125/CE for energy-related products
- Regulation (EU) 2017/1369 Energy labelling
- Delegated Regulation (EU) N. 811/2013
- Delegated Regulation (EU) N. 813/2013
- Delegated Regulation (EU) N. 814/2013



At the end of its life, the product should be not be disposed of as solid urban waste, but rather it should be handed over to a differentiated waste collection centre.

CONTENTS

1 GENERAL INFORMATION	4	3 COMMISSIONING AND MAINTENANCE	44
1.1 General Safety Information	4	3.1 Preparing for initial startup	44
1.2 Precautions	4	3.2 Initial startup	44
1.3 Description of the appliance	4	3.2.1 Adjustment of heating setpoint	45
1.4 Safety and control devices	5	3.2.2 Enable/disable the heating function	45
1.5 Identification	5	3.2.3 Adjustment of domestic setpoint	45
1.6 System layout	6	3.2.4 Enable/disable the domestic function	46
1.7 Technical specifications	8	3.2.5 Setting the heating parameters	46
1.8 Pump	10	3.2.6 Setting the domestic hot water parameters	49
1.9 Location of sensors	11	3.2.7 Heat request priority	50
1.10 Control panel	12	3.2.8 Special functions	50
2 INSTALLATION	14	3.2.9 Ignition failure	51
2.1 Unpacking the product	14	3.3 Checks during and after initial start-up	51
2.1.1 Positioning of labels	14	3.3.1 Burner control and adjustment	52
2.2 Overall dimensions and weights	14	3.3.2 Burner functioning and programming	53
2.3 Moving and removing the packing	15	3.4 Error List	60
2.4 Installation premises	17	3.4.1 Permanent Errors	60
2.4.1 Recommended minimum distances	17	3.4.2 Temporary Errors	60
2.5 Installation in older systems and systems requiring modernisation	17	3.4.3 Warnings	60
2.6 Water connections	18	3.5 Temporary or short-term shut-down	61
2.7 Boiler water circuit	18	3.6 Preparing for extended periods of disuse	61
2.8 Typical system schematic	19	3.7 Device cleaning and maintenance	61
2.9 Fuel connections	20	3.8 Annual cleaning	61
2.9.1 Dual-pipe system	21	3.8.1 Cleaning and maintaining the burner	61
2.9.2 Single-pipe system	21	3.8.2 Boiler exchanger cleaning	64
2.10 Preparation for the condensate drain	23	3.8.3 Checking and replacing the storage cylinder anode ..	65
2.10.1 Technical specifications of stack	23	3.9 Extraordinary cleaning	66
2.10.2 Connection to the stack	23	3.9.1 Cleaning the storage cylinder	66
2.11 System filling and emptying	27	3.10 External cleaning	66
2.11.1 Water quality requirements	27	3.11 Troubleshooting	67
2.11.2 Filling	27		
2.11.3 Emptying	28		
2.11.4 Heater emptying	28		
2.12 Wiring diagram	29		
2.13 Electrical connections	30		
2.14 Menu navigation	32		
2.15 Enter password	33		
2.16 Navigation scheme	34		
2.17 List of parameters	35		
		4 RECYCLING AND DISPOSAL	68











The following symbols are used in this manual:

 **CAUTION!** = Identifies actions that require caution and adequate preparation.

 **STOP!** = Identifies actions that you MUST NOT do.











1 GENERAL INFORMATION

1.1 General Safety Information

-  After removing the packaging, check the condition and completeness of the supply. If there are any problems, contact the company **RIELLO** that sold the equipment.
-  This product must be installed by a legally qualified heating engineer. On completion of the installation, the installer must issue the owner with a declaration of conformity confirming that the installation has been completed to the highest standards in compliance with the instructions provided by **RIELLO** in this instruction manual, and that it conforms to all applicable laws and standards.
-  This product must only be used for the purpose for which it is designed and made, as specified by **RIELLO**. **RIELLO** declines all responsibility, contractual or other, for damage to property or injury to persons or animals caused by improper installation, adjustment, maintenance or use.
-  The room where the boiler is installed must be properly ventilated to ensure a sufficient supply of air for correct combustion.
-  In case of water leaks disconnect the equipment from the power mains, close the water supply and promptly alert Technical Assistance Service **RIELLO** or professionally qualified personnel.
-  The boiler must be serviced at least once a year. The failure to perform annual maintenance work will void the warranty of the equipment.
-  Periodically check that pressure in the central heating circuit, when cold, is approximately 1.5 bar and below the maximum limit specified for the boiler. If this is not the case, contact the Technical Assistance Service **RIELLO** or professionally qualified personnel.
-  If the boiler is not going to be used for an extended period of time, perform the operations described later in this manual.
-  This manual is an integral part of the equipment and therefore must be stored carefully and must ALWAYS accompany the boiler even if it is sold to another Owner or User or transferred to another plant. If it is damaged or lost, request another copy from your local Technical Assistance Service **RIELLO**.
-  This manual must be read carefully so as to ensure the correct and safe installation, operation and maintenance of the appliance. The Owner must be adequately informed and trained on how to operate the appliance. Make sure that he/she is familiar with all the information required for safe system operation.

1.2 Precautions

The operation of any appliance that uses fuel, electrical power and water demands that a number of fundamental safety precautions be respected:

-  Do not allow children or infirm persons to operate the system unsupervised.
-  It is forbidden to use electrical devices or equipment, such as switches, appliances, etc. if there is a smell of gas or unburnt products. If so:
 - Ventilate the room, opening doors and windows
 - Close the fuel shut-off cock
 - Ask for the prompt intervention of the Technical Assistance Service
-  Do not touch the boiler while barefoot or wet.
-  Any technical or cleaning operation is forbidden before:
 - removing the power supply by setting the main switch of the equipment to (I) and the main switch of the system to (OFF)
 - closing the water and fuel shut-off valves
-  Do not tamper with or adjust the safety or control devices without prior authorisation and instructions from the manufacturer.
-  Never pull, disconnect, or twist the electrical cables coming from the appliance even if it is disconnected from the mains electricity supply.
-  Do not obstruct or restrict the vents in the room where the boiler is installed. Adequate ventilation is essential for correct combustion.
-  Do not expose the boiler to the elements. It is not designed for use outdoors.
-  It is prohibited to leave inflammable substances and containers in the room where the boiler is installed.
-  Do not dispose of packaging material into the environment, or leave it within the reach of children, since it can become a potential hazard. Dispose of packaging material in compliance with applicable legislation.
-  It is forbidden to operate the boiler without water.

1.3 Description of the appliance

The thermal unit **INSIEME EVOe 25 B/70 LN** is a hot water generator for the heating of environments and production of domestic hot water (DHW) by means of a vitrified heater. It can function at low temperature and is oil fuelled. The low NOx burner features a single-stage operation and a vertical steel combustion chamber. The boiler unit is effectively and accurately insulated with a high-density glass wool mat. The control panel includes a user interface with display and an electronic board for the thermal unit adjustment and control, which allows to manage the control and safety devices in compliance with the regulations in force.

1.4 Safety and control devices

The control panel, apart from managing the functions of the thermal unit **INSIEME EVOe 25 B/70 LN**, allows to highlight any anomaly which may affect its correct operation, ensuring the thermal unit safety by stopping it and automatically closing the burner light oil valve.

The burner control and adjustment board is also used to ensure the burner safety by managing its correct operation.

Any anomaly which may affect the generator operation forces it to stop (lock-out) and is promptly signalled with a numerical error code on the regulator display.

The following are installed on the water circuit:

- **Safety thermostat:** fitted on the generator body, it intervenes by stopping (permanent error) the thermal unit if the boiler temperature exceeds the limit threshold of 110°C;
- **Safety valve:** intervenes if the boiler pressure exceeds the limit threshold of 3 bar;
- **Pressure transducer:** sends a signal to the electronic regulator which views and continually checks the primary circuit pressure to switch on the generator or cause it to stop in case of low pressure;
- **Boiler temperature probes (delivery and return):** immersion probe on the delivery line of the generator is used by the regulator to view and check the delivery water temperature and check the correct switching on and off of the burner based on the programmed setpoint. The regulator uses the same probe to switch off the generator in case of overtemperature, before the triggering of the safety thermostat. The contact probe placed on the return line of the boiler is used by the regulator to view the return water temperature with which it calculates, together with the delivery temperature, the temperature difference between delivery and return (Δt), which allows regulating the modulation of the circulator in heating mode.
- **Domestic circuit temperature probe (heater):** the immersion probe in the heater is used by the regulator to view and check the domestic hot water temperature and to manage the relevant operating parameters (DHW Setpoint, DHW request, etc.).

⚠ The intervention of a safety device indicates a potentially dangerous malfunction in the system. Contact the manufacturer's Technical Assistance Service immediately.

⚠ Safety devices must only be replaced by the manufacturer's Technical Assistance Service using original spare parts. Refer to the spare parts catalogue supplied with the boiler. After making the repair, check that the appliance is working properly.

⊖ The appliance must not be put in service, even temporarily, when tampered safety devices are not in operation or have been tampered with.

1.5 Identification

The products are identified by:

Serial number plate

Contains the serial number, the model and the main technical data.

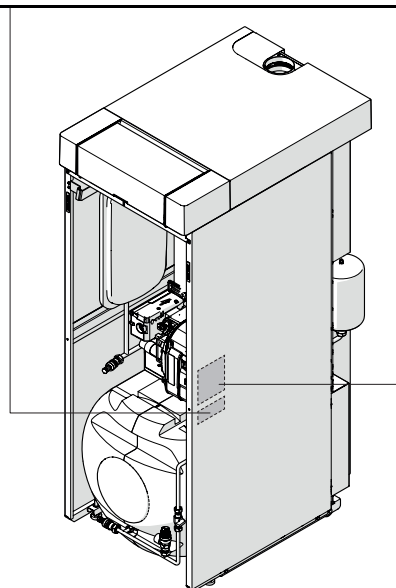
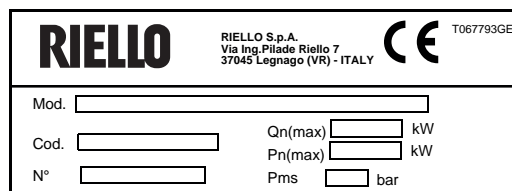

RIELLO		RIELLO S.p.A. Via Ing. Pilade Riello 7 37045 Legnago (VR) - ITALY		T067793GE		CE	
Mod. _____		Cod. _____		N° _____			
Qn(max) _____ kW		Pn(max) _____ kW		Pms _____ bar			
FASE DI DESTINAZIONE/PAIS DE DESTINATION/BESTIMMUNGSLAND/LAND VON BESTEMMUNG COUNTRY OF DESTINATION/PAIS DE DESTINOPAIS DE DESTINO:							
COMBUSTIBLE/COMBUSTIBLE/BRENNSTOFF/FUEL/COMBUSTIBLE/COMBUSTIVEL:							
TIPO/TYP/TYP/TYP/TIPO/TIPO:							
IP		NO _x =		mg/kWh			
V-Hz		W		%			
		Qn(min)=		kW		kW	
		Pn(min)=		kW		kW	
Pmw= bar T = °C		Qn(max)=		kW		kW D= l/min	
Pms= bar T = °C		Pn(max)=		kW		kW	

Data plate

This lists the technical specifications and performance of the product.

- DHW section
- Central heating section
- Qn** Rated heat input
- Pn** Rated useful heat output
- IP** Electric degree of protection
- Pmw** Maximum domestic operating pressure
- Pms** Maximum heating operating pressure
- T** Maximum permitted temperature
- η** Efficiency
- D** Specific flow rate
- NO_x** NO_x class

⚠ If these plates or any other means of clearly identifying the product are defaced, removed or lost, proper installation and servicing may be rendered difficult.

1.6 System layout

INSIEME EVOe 25 B/70 LN

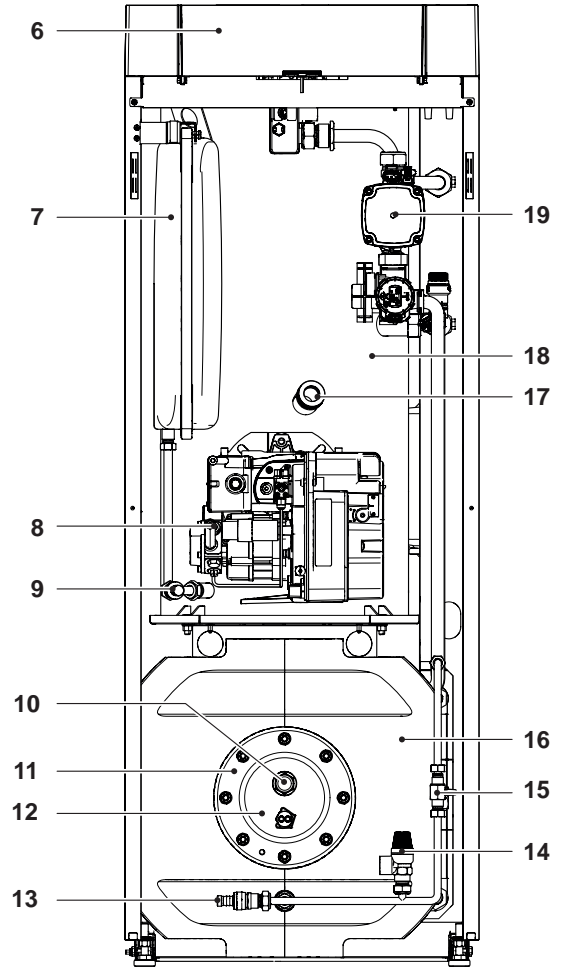
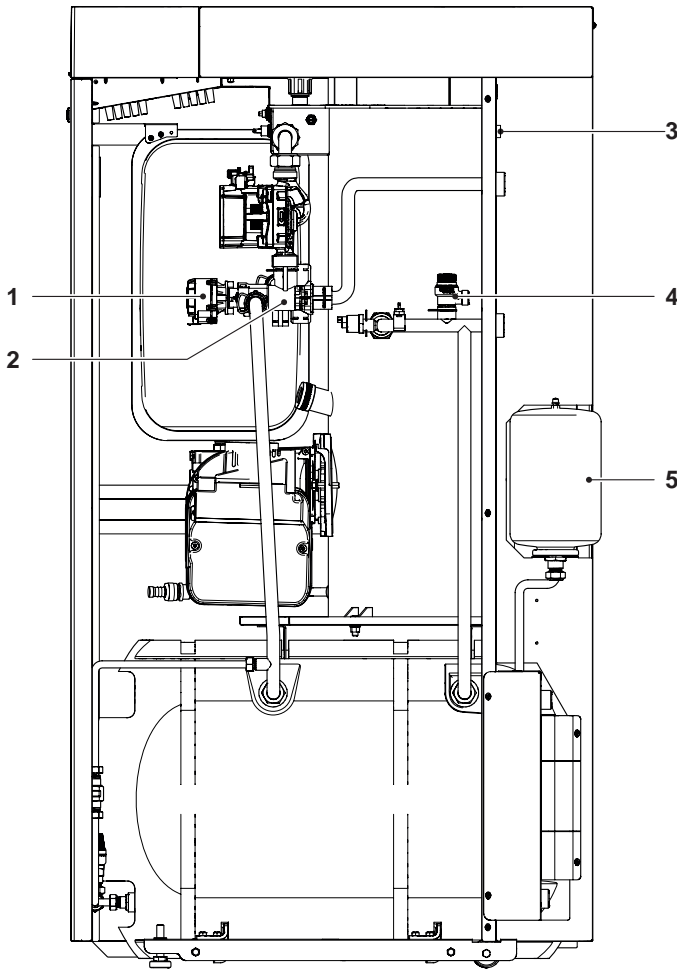

- 1 Electric actuator
- 2 3-way diverting valve
- 3 Main switch
- 4 Heating safety valve
- 5 Storage cylinder expansion vessel
- 6 Control panel
- 7 Heating expansion reservoir
- 8 Burner
- 9 Boiler drain cock
- 10 Magnesium anode
- 11 Storage cylinder inspection flange
- 12 Storage cylinder flange insulation
- 13 Storage cylinder drain cock
- 14 Storage cylinder safety valve
- 15 Storage cylinder fill cock
- 16 Storage cylinder with insulation
- 17 Flame inspection window
- 18 Boiler body
- 19 Pump

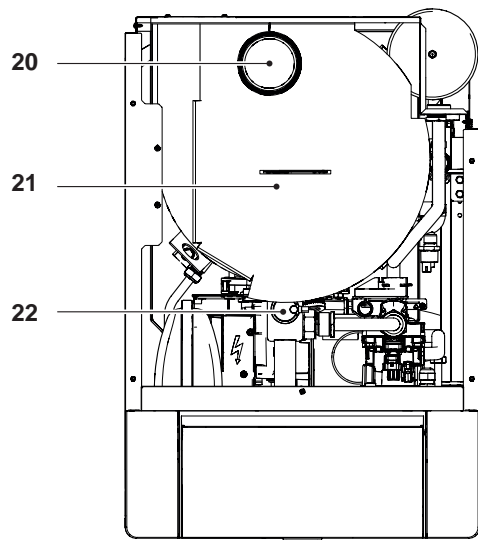

- 20 Exhaust flue duct
- 21 Flue gas box cover
- 22 Automatic bleed valve

BURNER

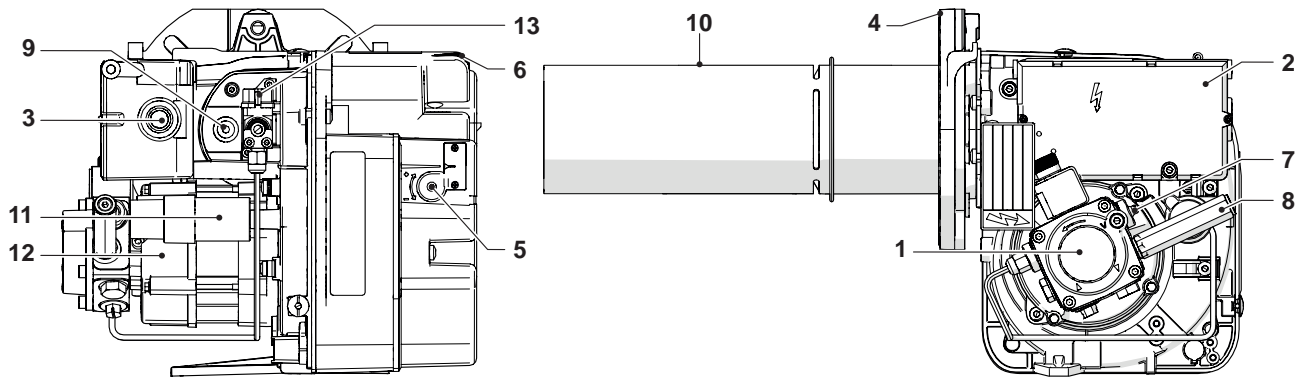

- | | | | |
|---|-------------------------------------|----|------------------------|
| 1 | Pump | 8 | Pressure gauge fitting |
| 2 | Burner controller | 9 | Photoresistor |
| 3 | Reset button with lockout indicator | 10 | Flame pipe |
| 4 | Flange with seal | 11 | Condenser |
| 5 | Air damper adjuster screw | 12 | Motor |
| 6 | Air intake | 13 | Heating element |
| 7 | Oil pump pressure adjuster screw | | |

OIL PUMP

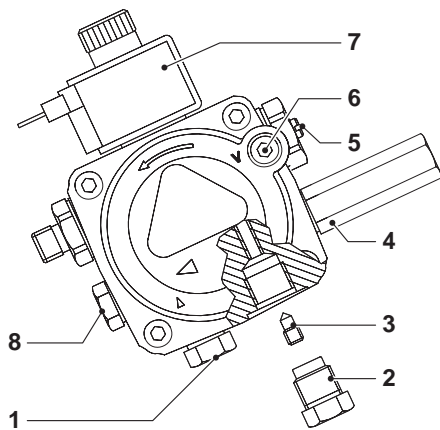

- | | |
|---|--|
| 1 | Suction port |
| 2 | Return |
| 3 | By-pass screw |
| 4 | Pressure gauge fitting |
| 5 | Pressure adjuster screw |
| 6 | Vacuum gauge fitting |
| 7 | Solenoid valve |
| 8 | Auxiliary pressure measurement fitting |

1.7 Technical specifications

DESCRIPTION			INSIEME EVOe 25 B/70 LN	
Device type			Mixed low temperature heating	
			B23-B23P-C13(*)-C33(*)-C43(*)-C53(*)-C63(*)-C83(*)	
Fuel			Heating fuel oil (light oil)	
Combustion chamber			vertical	
Maximum rated heat input at furnace referred to HVC (LCV)			28,1 (26,5)	kW
Useful (rated) heat output			25	kW
Maximum useful heat output			25,3	kW
30% heat output			7,7	kW
Efficiency class in central heating mode			B	
Seasonal energy efficiency in DHW mode			B	
Seasonal energy efficiency in central heating mode			η_s	86 %
Efficiency at rated heat output in high temperature mode referred to HCV			η_4	Pn (80-60°C) 90 %
Efficiency with nominal heat output and high temperature referred to LHV				Pn (80-60°C) 95,4 %
Efficiency at 30% rated heat output in low temperature mode referred to HCV			η_1	with return at 37°C 91,1 %
Efficiency at 30% with nominal heat output and low temperature referred to LHV				with return at 37°C 96,6 %
Energy efficiency in DHW mode			η_{wh}	77 %
Domestic load profile			XL	
Chimney losses with burner on at max. Pn (80-60°C)			3,6	%
Heat loss in standby mode			Pstby	44 W
				0,17 %
Annual energy consumption			QHE	84 GJ
Daily electrical energy consumption			Qelec	0,103 kWh
Annual electrical energy consumption			AEC	27,5 kWh
Daily fuel consumption			Qfuel	25,12 kWh
Annual fuel consumption			AFC	34,28 GJ
Noise level (sound power)			LWA	59 dB(A)
			NOx (referred to HCV)	92 mg/kWh
			NOx Class	3 n°
Emissions with maximum output (*)			CO2	12,5 %
			CO w.a. <	10 ppm
			Flue gas T	with nominal output (80-60°C) 100 °C
Smoke scale			<0,5	
Flue gas mass airflow with max nominal output (**)			10	g/s
Flue gas residual head with max power			20	Pa
Minimum operating pressure			0,5	bar
Maximum working pressure			3	bar
Lockout thermostat activation temperature			110	°C
Maximum adjustment temperature			82	°C
Minimum return temperature			37	°C
Boiler water capacity			33	l
Turbulators			16	n°
Volume of expansion vessel (CH)			8	l
Precharge of expansion vessel (CH)			1,5	bar

DESCRIPTION		INSIEME EVOe 25 B/70 LN	
Index of protection		X0D	IP
Power supply		230 V - 50 Hz	
Absorbed power supply (max)		205	W
Consumption at full load	Elmax	175	W
Consumption at part load	Elmin	53	W
Electrical consumption in standby mode		Psb	12

LCV: Lower calorific value of fuel

HCV: Higher calorific value of fuel

Test conditions:

- Room temperature 22°C
- Atmospheric pressure 1018 mbar

(*) Configurations possible only with the installation of the dedicated accessories (available separately).

(**) Values referred to atmospheric pressure at sea level.

DESCRIPTION		INSIEME EVOe 25 B/70 LN	
Type of storage cylinder		Vitrified	
Storage cylinder layout		Horizontal	
Heat exchanger layout		Horizontal	
Maximum power absorbed		23	kW
DHW temperature setting range		40-70	°C
Storage cylinder capacity		69	l
Coil water capacity		4	l
Heat exchange surface area		0,8	m ²
Production of domestic water with (ΔT 35°C) (*)		564	l/h
Water draw in 10 minutes with storage cylinder at 48°C		98	l
Water draw in 10 minutes with storage cylinder at 60°C		190	l
Specific flow rate (EN 13203)		20	l/min
Reset time (ΔT 35°C)		12	min
Maximum operating pressure of storage cylinder		6	bar
Volume of expansion vessel (DHW)		2	l
Precharge of expansion vessel (DHW)		3,5	bar
Insulation thickness		30	mm
Quantity/diameter/length of magnesium anode		1/22/400	mm
Flange internal diameter		130	mm
Length of 2-tube probe holder (\varnothing 8 mm)		210	mm
Maximum operating pressure of coil		3	bar
Maximum operating temperature		80	°C
Dissipation according to EN 12897:2006 $\Delta t = 45^\circ\text{C}$ (environment 20°C and storage at 65°C)		110	W
Discharges according to UNI 11300		2,44	W/K
Domestic hot water continuous efficiency (DHW 10-45°C)	80°C	Δt 20°C	23
			564
Running time to warm up the heater at 60°C	80°C	Δt 20°C	12
Thermal output coefficient NL according to DIN 4708 (**)		1,51	

(*) Inlet temperature of 10°C and average outlet temperature of 45°C with coil inlet temperature of 80°C.

(**) The NL index indicates a number of apartments having 3.5 people that can be fully supplied, with a 140-litre bathtub and two other drawing points.

1.8 Pump

DESCRIPTION	INSIEME EVOe 25 B/70 LN	
Electrical consumption	52	W
EEl Part 3 (*)	≤ 0,20	
P L,Avg (**)	≤ 23	W
Minimum pressure at pump suction inlet	0,5	bar

(*) Energy efficiency rating according to regulations 641/2009–622/2012

(**) Approximate average annual electricity consumption according to regulations 641/2009–622/2012

PUMP CURVES

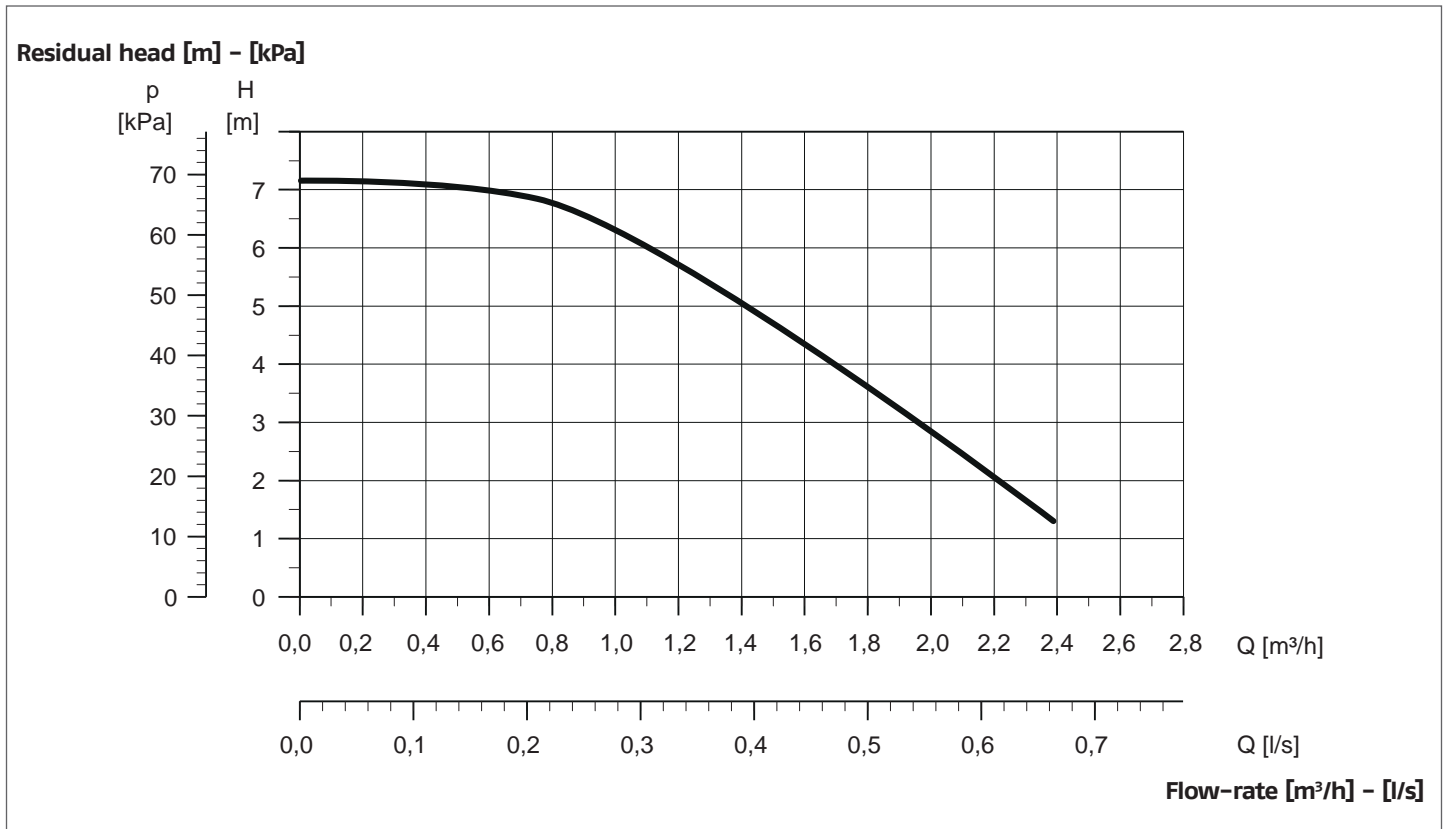

⚠ When starting up for the first time and at least once a year, it is useful to check the rotation of the circulator pump shaft because, especially after long periods of inactivity, deposits and/or residues can prevent free rotation.

⚠ Before loosening or removing the circulator cap, protect the electric devices located underneath from any water that exits.

⊘ It is prohibited to operate the circulators without water.

1.9 Location of sensors

INSIEME EVOe 25 B/70 LN

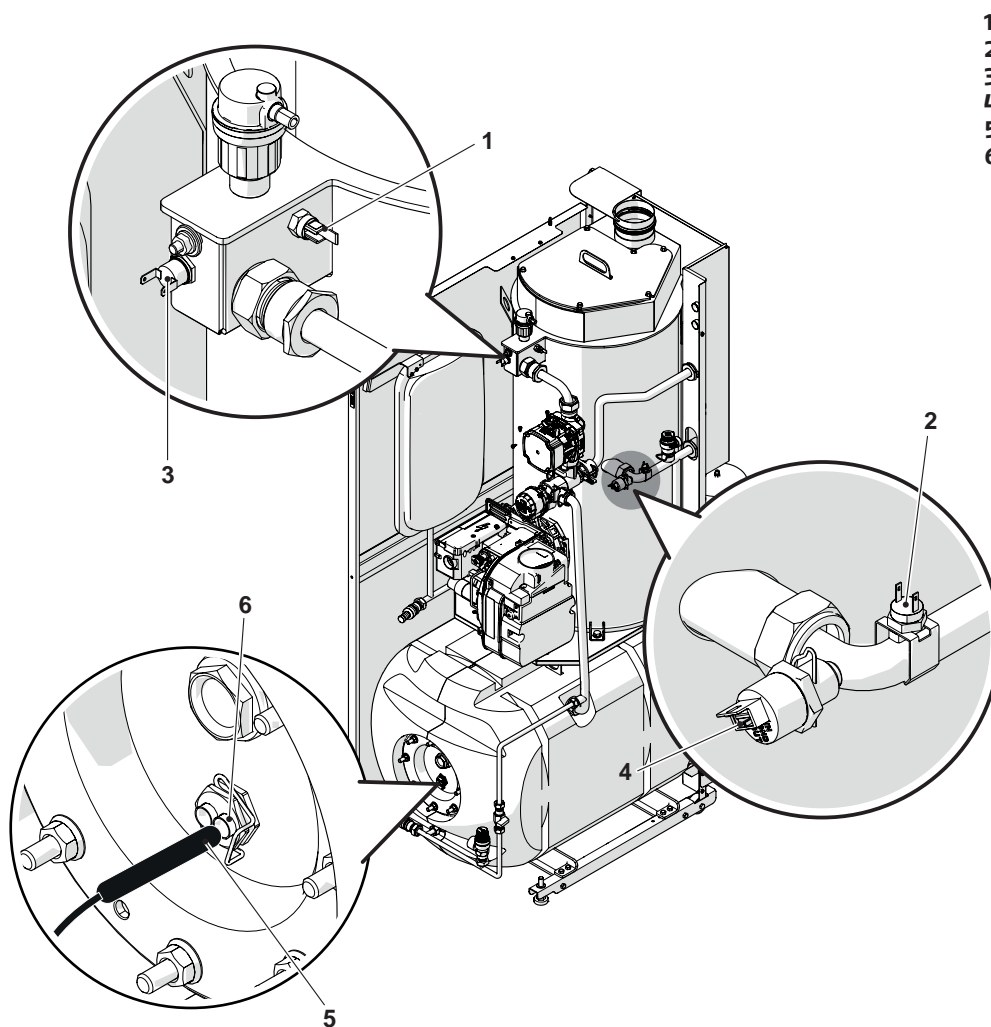

- 1 Delivery temperature probe
- 2 Return temperature probe
- 3 Safety thermostat
- 4 Pressure transducer
- 5 Boiler sensor
- 6 Heater sensor bath

1.10 Control panel

Controls interface

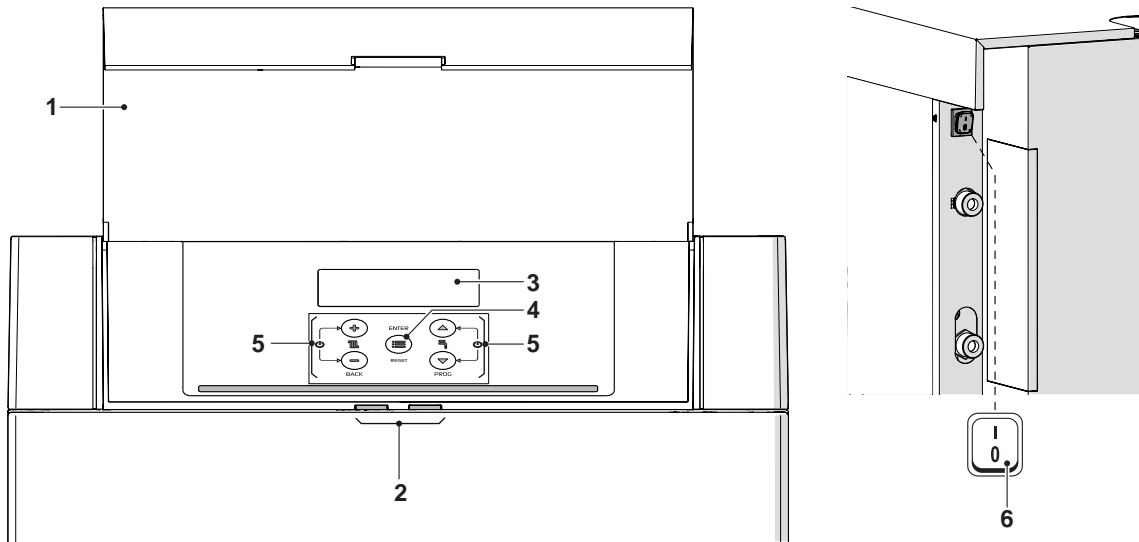

- 1 Door
- 2 Light guide
- 3 Rear light display
- 4 ENTER/RESET key: it allows accessing the main menu and restoring the operation after a stop due to an anomaly
- 5 Navigation keys
- 6 Main switch (located on the equipment rear wall)

Light Guide displaying

STATUS	DESCRIPTION
Green blinking	Thermal unit drain cycle and initialization in progress after the power supply reset.
Steady green	Thermal unit on
Steady red	Thermal unit in alarm mode
Red blinking	Thermal unit in lock-out mode

Display visualisation

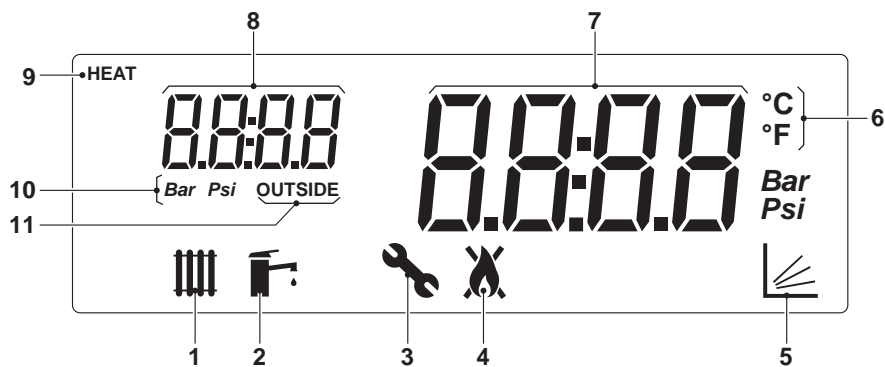

- 1 Icon displayed when heating mode is enabled. Blinking when there is a heat demand
- 2 Icon displayed when DHW mode is enabled. Blinking when there is an DHW Demand
- 3 Icon displayed when entering the "Installer" menu
- 4 Icon displayed when the burner of the equipment is on. The icon will be marked with a cross in case of Permanent or Temporary error.
- 5 Icon displayed when the climatic mode operation is active (Par. 2001= 1 or 2)
- 6 Celsius/Fahrenheit temperature
- 7 Displays current value
- 8 Displaying of system pressure or parameter number or external temperature
- 9 Icon displayed when the circulator is operating
- 10 Pressure in Bar/Psi
- 11 Icon displayed when the outdoor probe is connected

2 INSTALLATION

2.1 Unpacking the product

The **INSIEME EVOe 25 B/70 LN** boiler is supplied on a pallet, protected by a non-scratch cloth and a triple wall cardboard box. Check immediately that there is no damage and that the boiler is exactly as ordered. The product specifications are shown on the outside of the packing: model, power, equipment, fuel type. If there is any difference between the boiler ordered and that received, contact your agent, the warehouse or the sales department at head office immediately.

The following items are delivered in a plastic bag (1) inside the boiler:

- User manual
- Installation and maintenance manual
- Hydraulic test certificate
- Energy label
- Conventional warranty conditions

There is another plastic bag (2) inside the boiler, containing the two hoses for light oil (G1/4" - G 3/8")

2.1.1 Positioning of labels

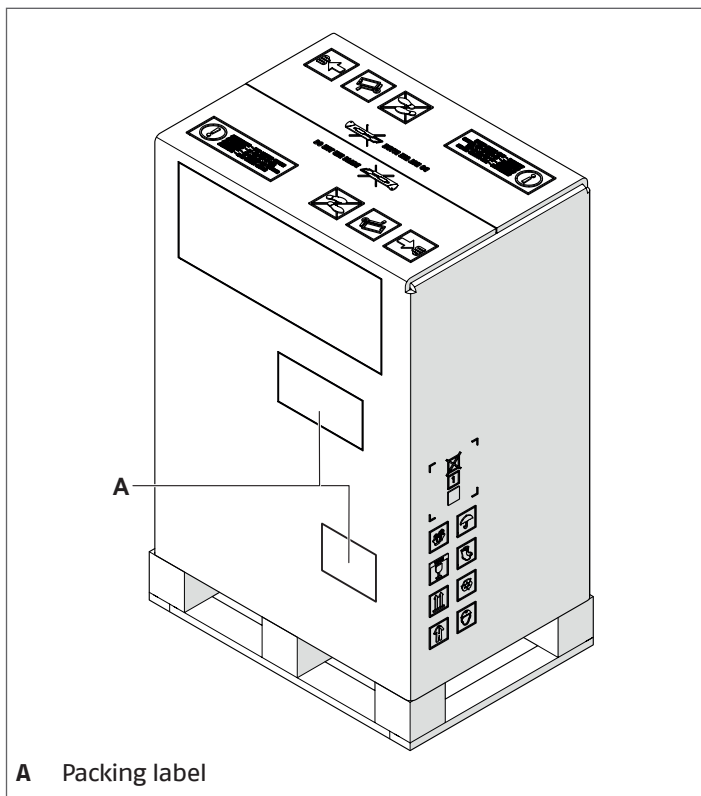

2.2 Overall dimensions and weights

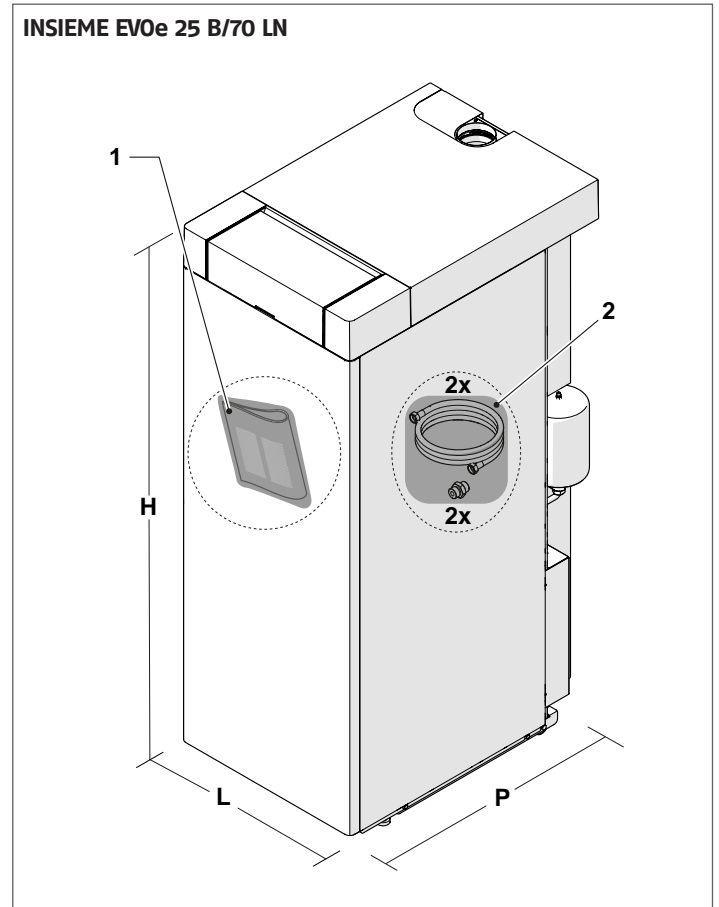

Description	INSIEME EVOe 25 B/70 LN	
L	500	mm
P	736	mm
H	1353	mm
Net weight	151	kg

⚠ The instruction manual is an integral part of the appliance; therefore, it should be read and stored carefully.

⚠ Keep the documentation envelope in a safe place. Any replacement documents must be ordered from Riello S.p.A. who reserve the right to charge for the cost of the replacement.

2.3 Moving and removing the packing

⚠ Wear suitable personal protection equipment when moving the boiler and removing the packing. Only use lifting equipment that is suitable for the weight involved.

Proceed as follows to remove the packing:

- remove the straps (A) fixing the packing to the pallet;

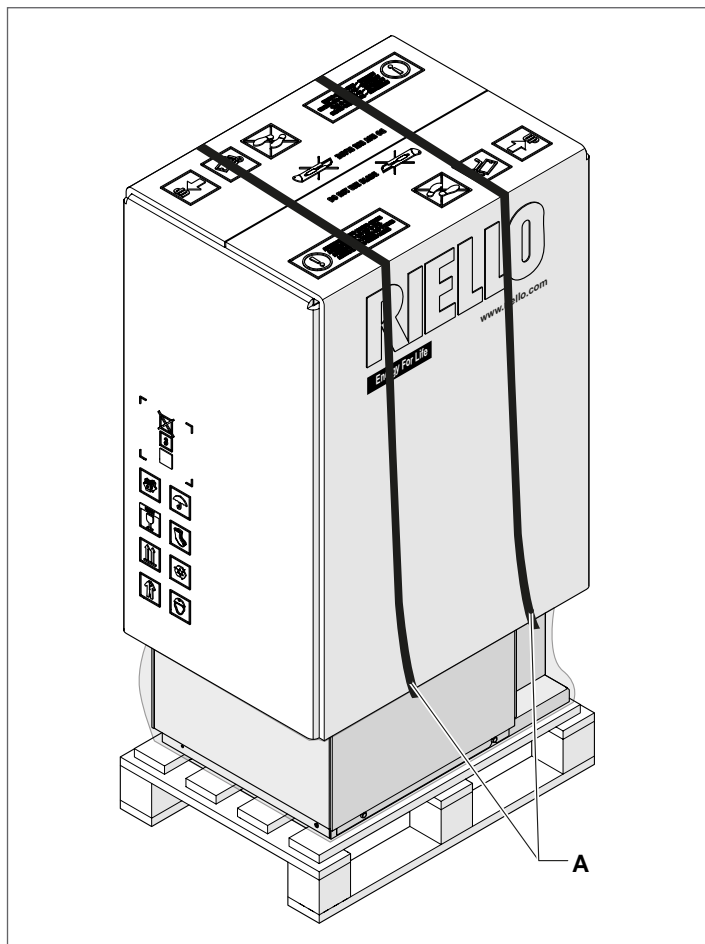

- remove the cardboard packing and non-scratch cloth.

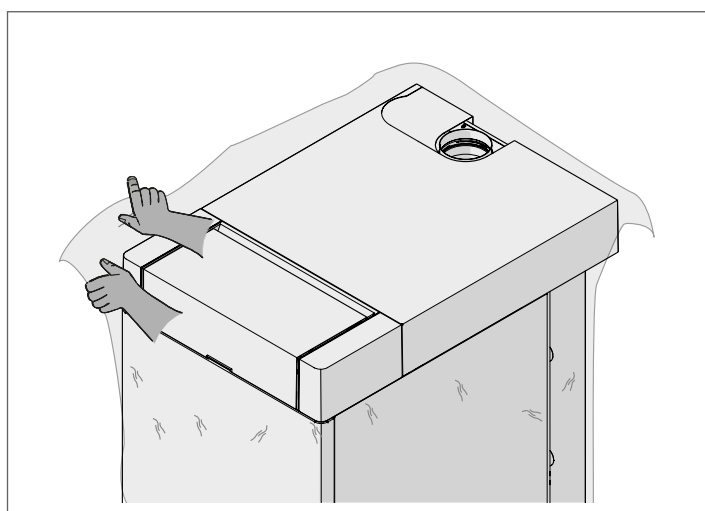

⊖ Do not dispose of packaging material into the environment, or leave it within the reach of children, since it can become a potential hazard. Dispose of packaging material in compliance with applicable legislation.

Once the packaging has been removed, remove the fixing screw (2) and extract the front panel (1).

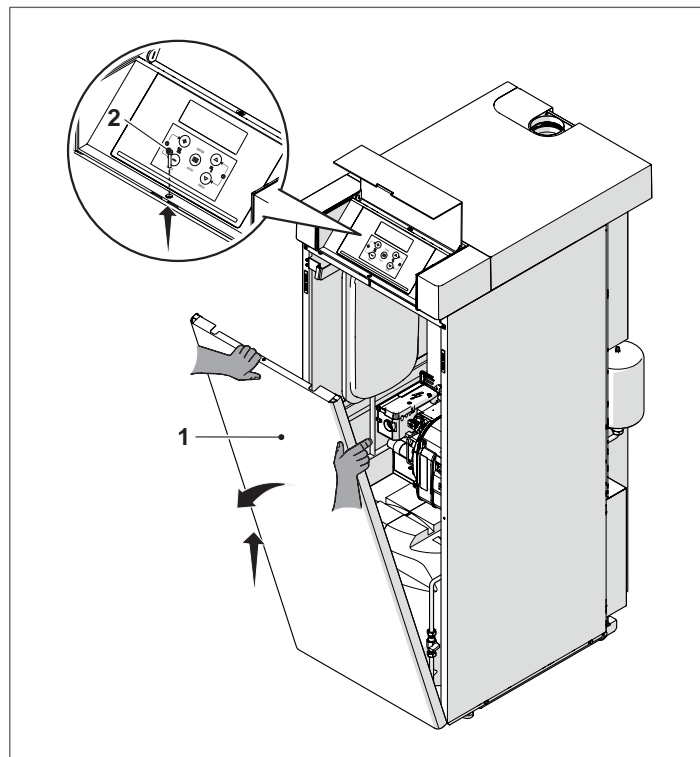

Locate the bag containing the documentation, extract the energy label and apply it to the boiler casing.

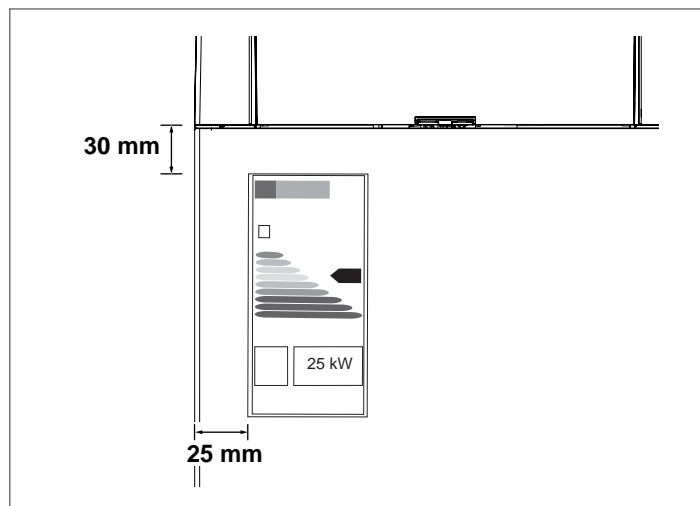

To move the boiler manually, proceed as follows:

- Unscrew the screws (1) securing the boiler to the pallet;
- remove the fixing screw (2) and extract the front panel (3).;

Use lifting equipment suitable for the weight involved.

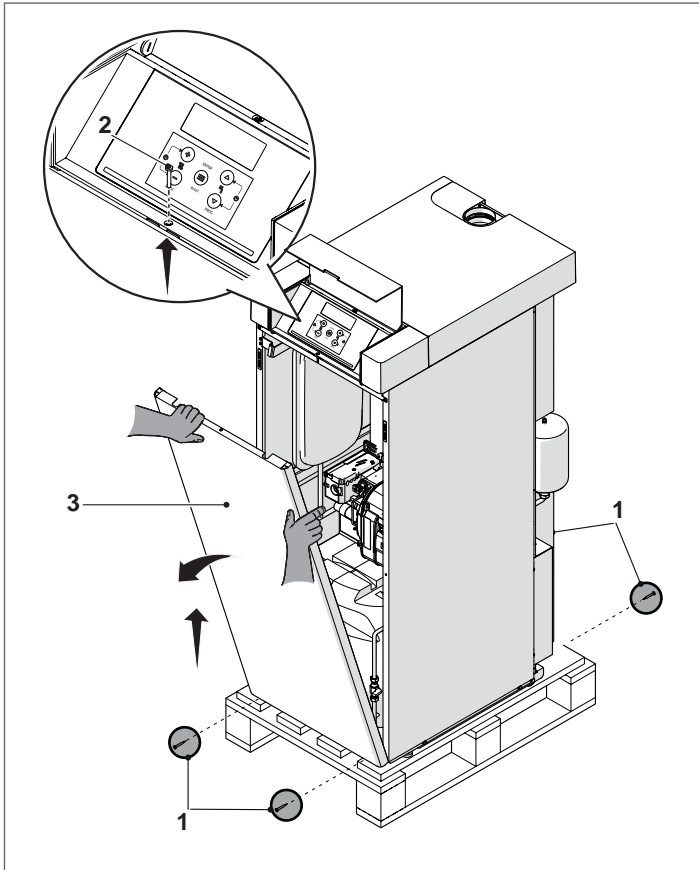

- lift the thermal unit by inserting two pipes (3) with a diameter of 1" through the suitable holes (4) on the upper part of the thermal unit.

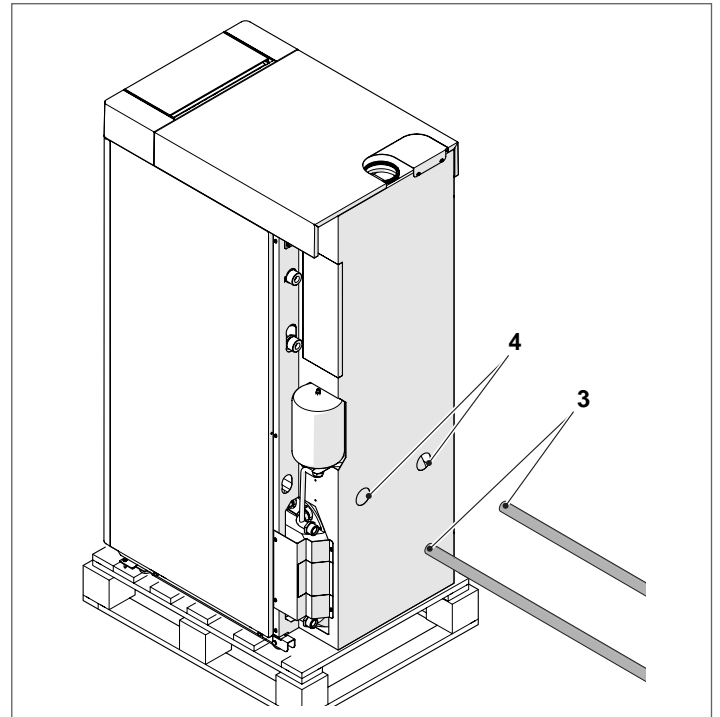

⚠ Take care because the boiler might swing when lifted.

2.4 Installation premises

The thermal unit **INSIEME EVOe 25 B/70 LN** must be installed in rooms with appropriately sized vent openings which comply with the Technical Standards and Regulations in force in the place of installation.

- ⚠** When installing the boiler, allow sufficient space around it to access all safety and control devices and to permit easy maintenance.
- ⚠** Check that the electric protection level of the appliance is suitable for features of the room where it is installed.
- ⚠** Make sure that comburent air is not contaminated by substances containing chlorine or fluorine (elements found in sprays, paints, detergents etc.).
- ⊖** These boilers must be installed indoors. They are not designed for outside use.
- ⊖** Do not obstruct or restrict the air vents in the room where the boiler is installed. A free air supply is essential for correct combustion.

2.4.1 Recommended minimum distances

This figure shows the minimum installation distances that must be respected in order to allow proper maintenance of the boiler.

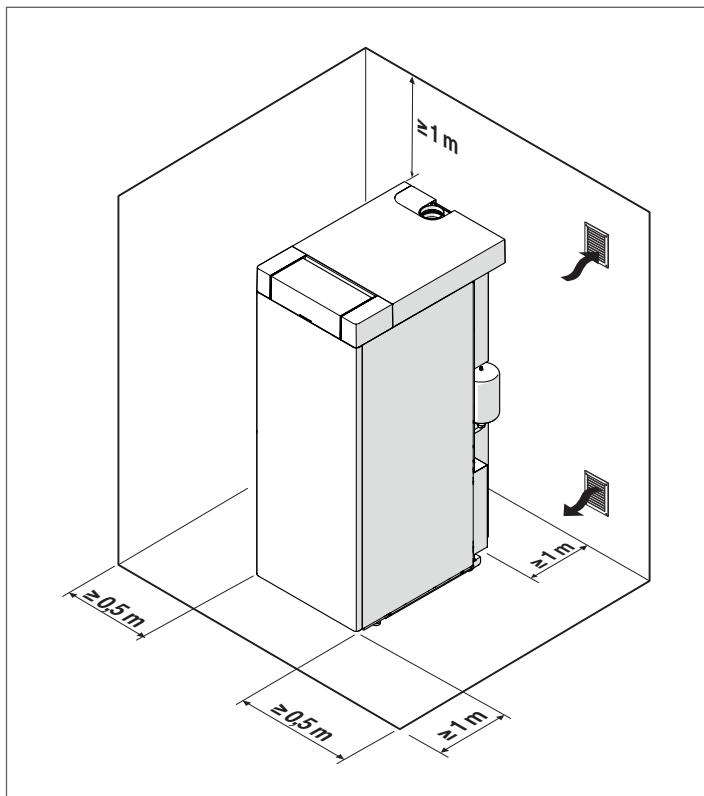

2.5 Installation in older systems and systems requiring modernisation

When installing these boilers in older systems or systems requiring modernisation, always perform the following checks:

- Make sure that the flue is able to withstand the temperature of the combustion gases and that it has been designed and made in compliance with applicable standards. The flue must also be as straight as possible, sealed, insulated and not blocked or choked
- Make sure that the electrical supply system has been installed by a qualified electrician in compliance with applicable standards
- Make sure that the fuel feed line and any storage tank are made and installed in compliance with applicable standards
- Make sure that expansion vessels are big enough to contain the additional volume generated by thermal expansion
- Make sure that the flow rate, head and direction of flow of the pumps are suitable and correct
- Make sure that the central heating circuit has been flushed out to remove all sludge and lime scale, and that it has been bled and seal tested
- Make sure that a suitable water treatment system is installed if the quality of the supply/recirculation water so demands. (Refer to the reference values on page 27); See **RIELLO's** Catalogue

- ⚠** The manufacturer declines all responsibility for damage caused by incorrectly constructed flue systems.

2.6 Water connections

The following table gives the dimensions and positions of the water fittings for **INSIEME EVOe 25 B/70 LN** boilers. Before installing the boiler, flush out all the pipes of the central heating circuit to remove any machining residues.

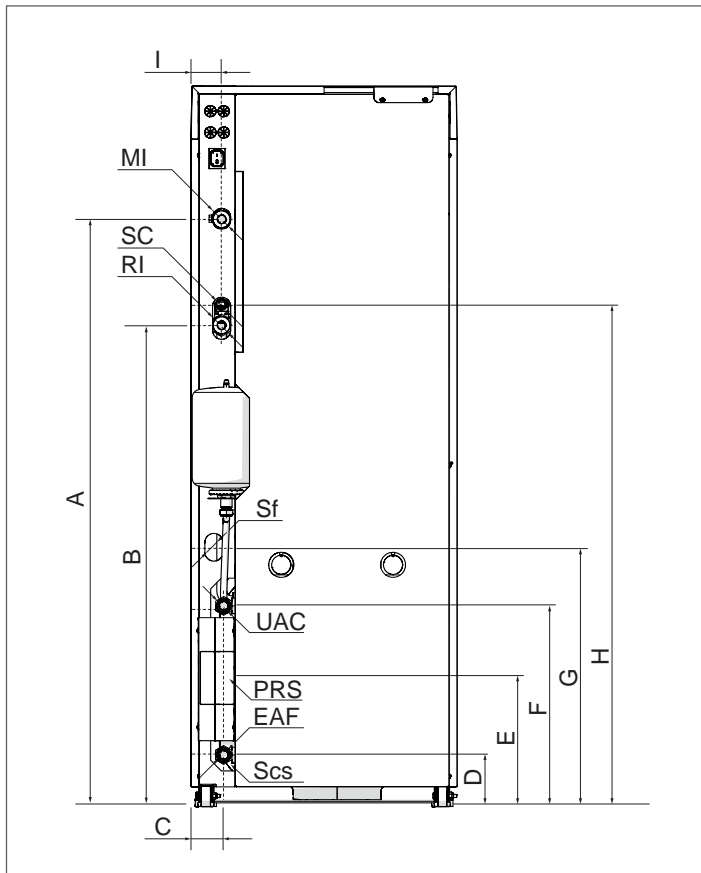

DESCRIPTION	INSIEME EVOe 25 B/70 LN	
A	1103	mm
B	904	mm
C	57,5	mm
D	97	mm
E	220	mm
F	377	mm
G	687	mm
H	1076	mm
I	38	mm
MI	(system delivery line)	1" M ∅
RI	(system return line)	1" M ∅
UAC	(domestic hot water outlet)	3/4" M ∅
DRP	(domestic recirculation preset)	3/4" M ∅
EAF	(domestic cold water inlet)	3/4" M ∅
SC	(safety valve drain)	21 ∅ mm
Sf	(automatic drain valve drain)	11 ∅ mm
Dsd	(domestic safety valve drain)	21 ∅ mm

2.7 Boiler water circuit

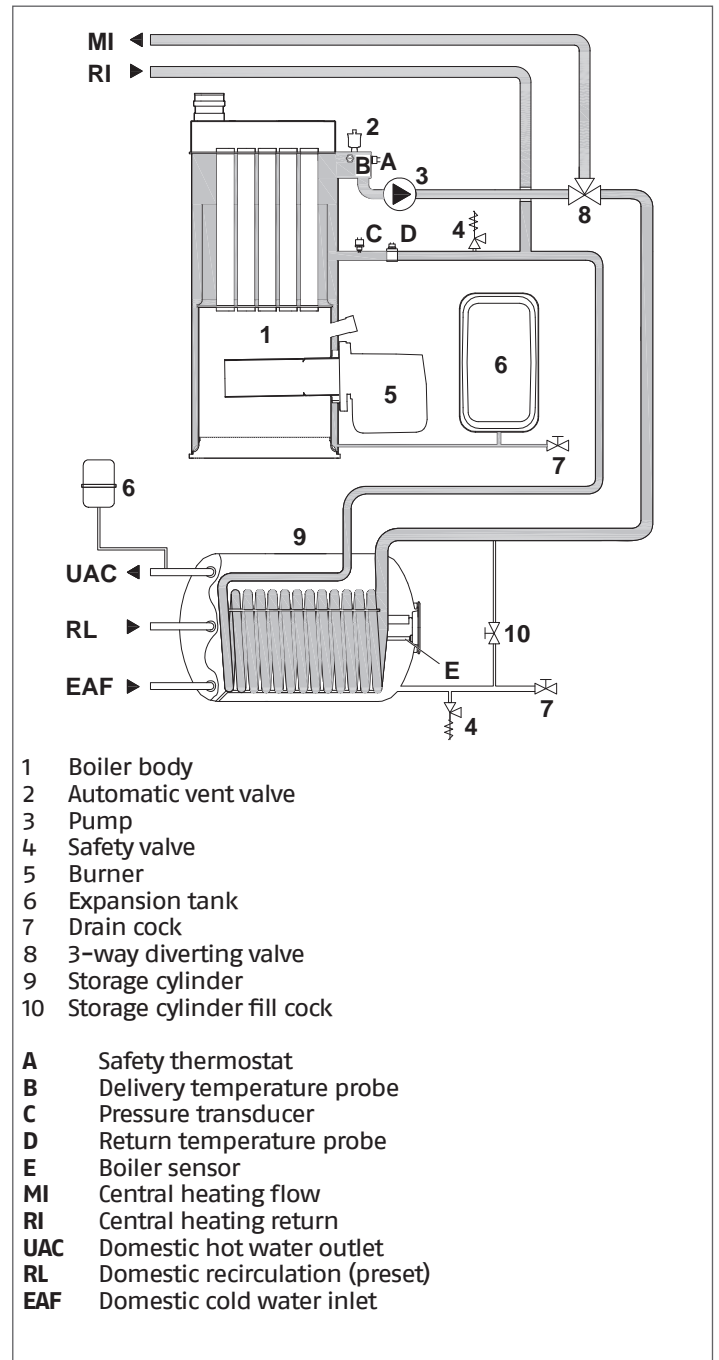

- 1 Boiler body
- 2 Automatic vent valve
- 3 Pump
- 4 Safety valve
- 5 Burner
- 6 Expansion tank
- 7 Drain cock
- 8 3-way diverting valve
- 9 Storage cylinder
- 10 Storage cylinder fill cock

- A Safety thermostat
- B Delivery temperature probe
- C Pressure transducer
- D Return temperature probe
- E Boiler sensor
- MI Central heating flow
- RI Central heating return
- UAC Domestic hot water outlet
- RL Domestic recirculation (preset)
- EAF Domestic cold water inlet



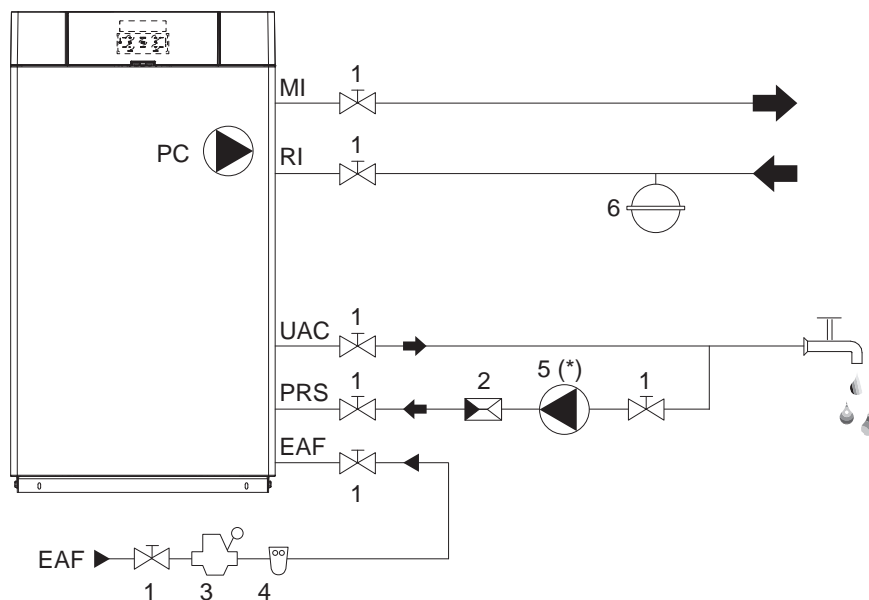



2.8 Typical system schematic



- 1 Isolating valve
- 2 Non-return valve
- 3 Pressure reducer
- 4 Water softener filter
- 5 DHW circulation pump
- 6 Expansion tank

- PC Thermal unit circulation pump
- MI Central heating flow
- RI Central heating return
- EAF Domestic cold water inlet
- DRP DHW recirculation preset
- UAC Domestic hot water outlet

(*) Circulator pump not controlled by the thermal unit regulator

-  Do not use a check valve in the hydraulic connections to the heating system consumption points.
-  The safety valves must be connected to a suitable collection and drain system.
-  The selection and the installation of the components of the system is the responsibility of the installer, who must operate in accordance with good practice and current Legislation.
-  If needed, water supplies and recovery circuits must be conditioned by suitable treatment systems. Refer to the values listed in the table on page 27.
-  Domestic hot water and central heating circuits must be completed with expansion vessels of adequate capacity and suitable, correctly-sized safety valves. The discharge of safety valves and appliances must be connected to a suitable collection and disposal system (see Catalogue for compatible accessories).
-  It is prohibited to operate the circulators without water.

2.9 Fuel connections

The boiler **INSIEME EVOe 25 B/70 LN** is supplied with two hoses for the light oil supply to the burner. They must be connected by the installer.

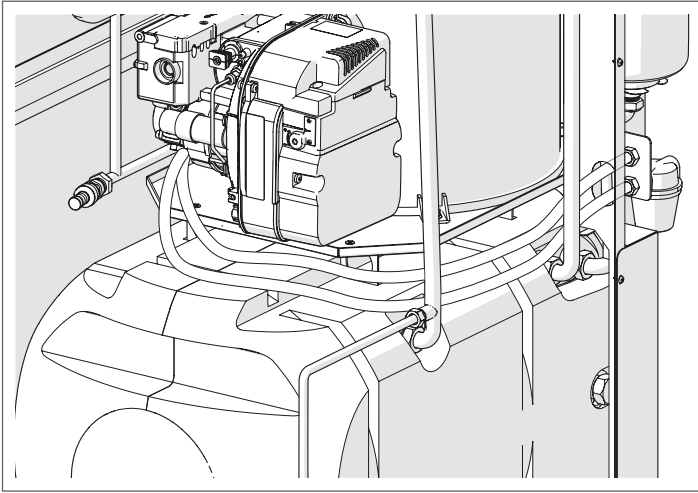

The connection to the light oil pump suction must be made directly on the filter (1) (accessory); the return pipe must be connected to the preset union (2). Make sure that these connections are oil tight.

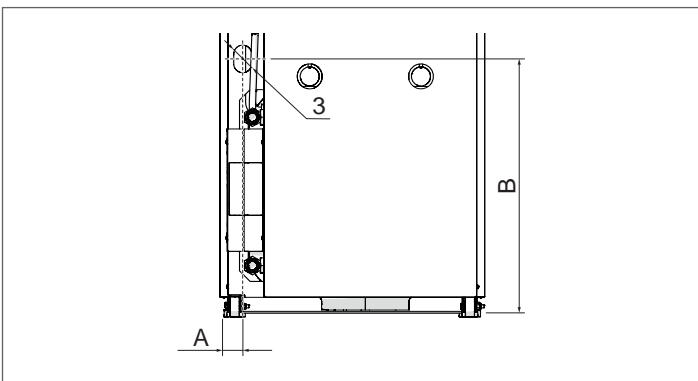
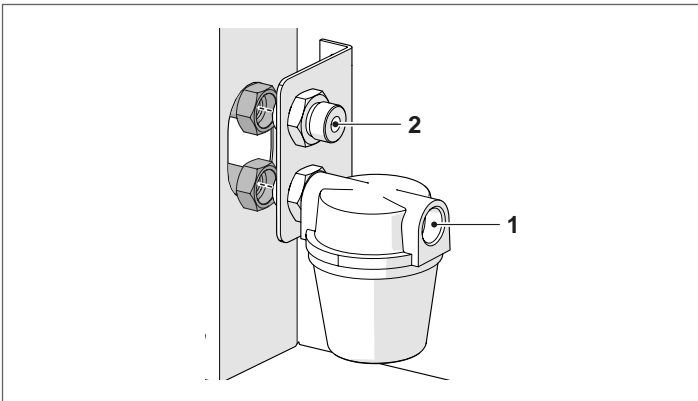

Description	INSIEME EVOe 25 B/70 LN	
Fittings	2x3/8" M	∅
A	45	mm
B	490	mm

If the oil feed system is in negative pressure, the return line must reach the same height as the suction line. This avoids having to install a bottom valve, which would be essential if the return hose were to be located above the level of the fuel.

⚠ The installer must ensure that the negative pressure differential in the oil feed never exceeds 0.4 bar (30 cm Hg). If this value is exceeded, the fuel oil will release gas. Make sure that the oil hoses are perfectly oil-tight.

⚠ Clean out the oil tank at suitable intervals.

⚠ The fuel supply system must be suitable for the burner capacity and must be equipped with all the safety and control devices required by the Standards in force. For its size, refer to the table on page "21 22" of paragraph "Priming the pump".

⚠ A filter must be installed in the oil feed line.

⚠ Before starting the thermal unit, make sure that the return pipe line is not clogged. An excessive back pressure would cause the breakage of the circulator seal.

⚠ On completion of the installation, check that all joints are sealed.

Light oil pump

⚠ Before starting the burner, make sure that the tank return line is not clogged. Obstructions in the line could cause the sealing organ located on the pump shaft to break.

The pump is designed to allow working with two pipes. For single pipe operation undo the return plug (2), remove the by-pass screw (3) and then tighten the plug (2) again.

⚠ The suction plug (1) is made of plastic. Once removed, it must not be used again. In single-pipe installations the return plug (2) must be absolutely made of steel.

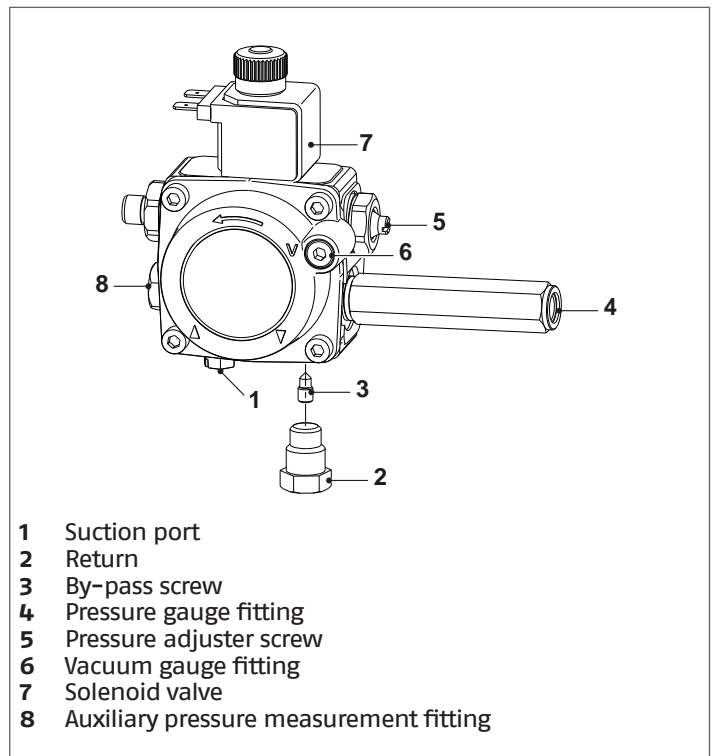

- 1 Suction port
- 2 Return
- 3 By-pass screw
- 4 Pressure gauge fitting
- 5 Pressure adjuster screw
- 6 Vacuum gauge fitting
- 7 Solenoid valve
- 8 Auxiliary pressure measurement fitting

2.9.1 Dual-pipe system

Dual-pipe vacuum systems have a negative fuel pressure (depression) at the burner inlet.

They typically have the tank at a lower height than the burner. The return line should terminate in the light oil tank at the same level as the suction line; in this case a non-return valve is not necessary.

Should however the return line arrives over the fuel level, the non-return valve is indispensable.

⚠ You are advised to use additional filters on the fuel supply line. The Manufacturer recommends the use of a good quality fuel filter on the tank and a secondary filter (supplied as an accessory) to protect the pump and the nozzle from contamination.

Priming the pump

⚠ Before igniting the burner, make sure that the return pipe is not obstructed; any obstruction will cause the pump's sealing devices to break.

To prime the oil pump simply start up the burner and check for a flame.

If the burner enters lockout before any fuel reaches it, wait at least 20 seconds then turn the function selector to position (II) "Reset burner" for at least 1 second before returning it to position (I). Wait for the burner to complete the entire ignition cycle again, up to the ignition of the flame.

⚠ The installer must ensure that the negative pressure differential in the oil feed never exceeds 0.4 bar (30 cm Hg). If this value is exceeded, the fuel oil will release gas. Make sure that the oil hoses are perfectly oil-tight.

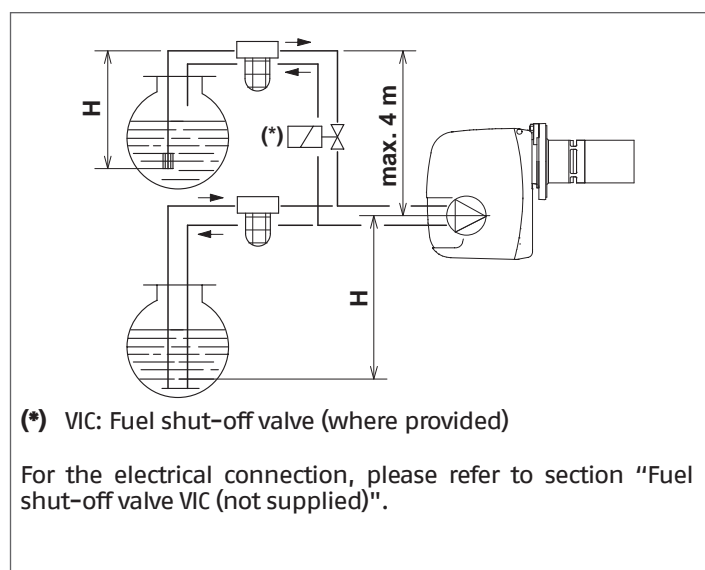

⚠ Where a fuel shut-off valve (VIC) is to be installed on the diesel gas supply circuit to the burner, closure of the valve must be delayed to prevent the section of hose between the pump and the valve going into negative pressure (empty).

In parameter 2079 it is possible to set the delay time (seconds) of the closing of the VIC valve with respect to the burner. The value to be set must always be \geq than the post-ventilation time of the burner.

H (m)	L (m)	
	Øi (8mm)	Øi (10mm)
0	35	100
0,5	30	100
1	25	100
1,5	20	90
2	15	70
3	8	30
3,5	6	20

H = Height difference

L = Maximum length of suction hose

Øi = Internal diameter of hose

The table shows the approximate maximum lengths for the supply line, depending on the height difference, length and diameter of the fuel line.

2.9.2 Single-pipe system

Pressurised single-pipe systems have a positive fuel pressure at the burner inlet.

Usually the tank is higher than the burner, or the fuel pumping systems are on the outside of the boiler.

Single-pipe vacuum systems have a negative fuel pressure (depression) at the burner inlet.

Usually the tank is lower than the burner.

⚠ You are advised to use additional filters on the fuel supply line. The Manufacturer recommends the use of a good quality fuel filter on the tank and a secondary filter (supplied as an accessory) to protect the pump and the nozzle from contamination.

Priming the pump

On single-pipe pressurised systems, simply loosen the vacuumeter cap and wait until the fuel comes out.

On single-pipe vacuum systems, switch on the burner and wait for ignition.

To prime the oil pump simply start up the burner and check for a flame.

If the burner enters lockout before any fuel reaches it, wait at least 20 seconds then turn the function selector to position (II) "Reset burner" for at least 1 second before returning it to position (I). Wait for the burner to complete the entire ignition cycle again, up to the ignition of the flame.

⚠ The installer must ensure that the supply pressure does not exceed 0.5 bar. Above this level, the pump seal is too stressed.

Single-pipe pressurised systems

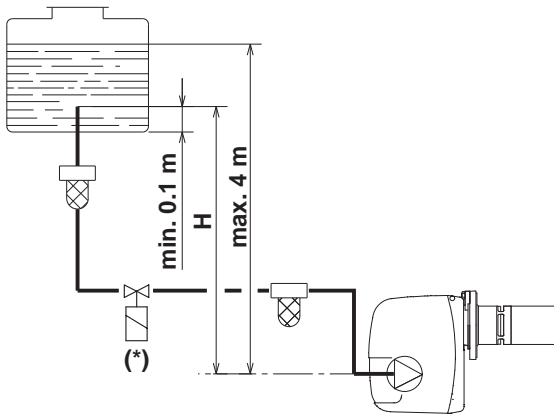

(*) VIC: Fuel shut-off valve (where provided)

For connecting the electricity, see paragraph "Fuel shut-off valve VIC (not supplied)".

Single-pipe vacuum systems

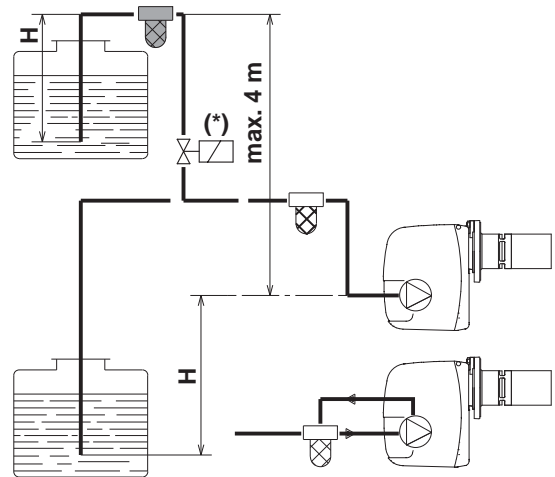

(*) VIC: Fuel shut-off valve (where provided)

For connecting the electricity, see paragraph "Fuel shut-off valve VIC (not supplied)".

⚠ Where a fuel shut-off valve (VIC) is to be installed on the diesel gas supply circuit to the burner, closure of the valve must be delayed to prevent the section of hose between the pump and the valve going into negative pressure (empty). In parameter 2079 you can set the time delay (seconds) on the closure of the VIC valve with respect to the burner. The value to be set must always be \geq the burner's post-ventilation time.

⚠ Where a fuel shut-off valve (VIC) is to be installed on the diesel gas supply circuit to the burner, closure of the valve must be delayed to prevent the section of hose between the pump and the valve going into negative pressure (empty). In parameter 2079 you can set the time delay (seconds) on the closure of the VIC valve with respect to the burner. The value to be set must always be \geq the burner's post-ventilation time.

H (m)	L (m)	
	Øi (8mm)	Øi (10mm)
0,5	10	20
1	20	40
1,5	40	80
2	60	100

H = Height difference
L = Maximum length of suction hose
Øi = Internal diameter of hose

H (m)	L (m)	
	Øi (8mm)	Øi (10mm)
0	35	100
0,5	30	100
1	25	100
1,5	20	90
2	15	70
3	8	30
3,5	6	20

H = Height difference
L = Maximum length of suction hose
Øi = Internal diameter of hose

NOTE:
The tables show the approximate maximum lengths for the supply line, depending on the height difference, length and diameter of the fuel line.

2.10 Preparation for the condensate drain

The smoke duct (1) and the chimney (2) must be made in accordance with the standards, current legislation and local regulations.

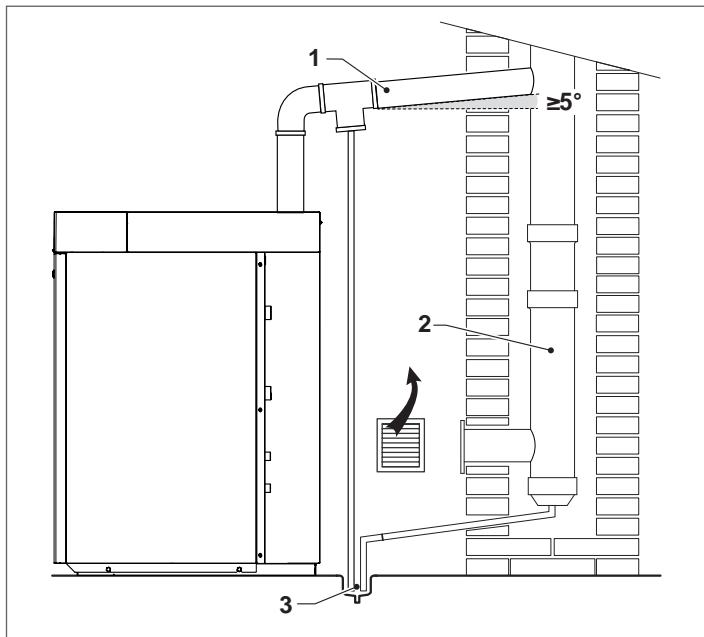

⚠ The condensate drain system (3) must conform to national and local legislation and standards.

⚠ The stack fitting is equipped with a seal (A). Do not use pipes with riveted overlaps to construct the flue.

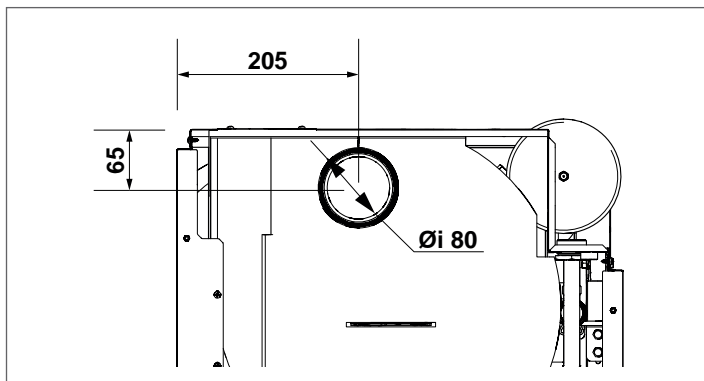
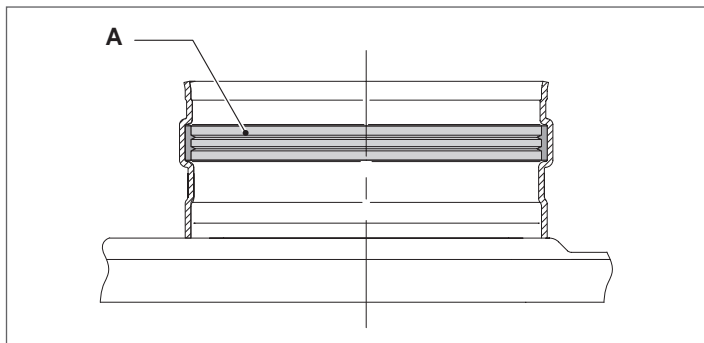

INSIEME EVOe 25 B/70 LN boilers derive their comburent air from the room in which they are installed. Suitable air vents must therefore be provided in compliance with applicable laws and standards.

⊖ Do not obstruct or restrict the air vents in the room where the boiler is installed. Adequate ventilation is essential for correct combustion and functioning.

2.10.1 Technical specifications of stack

The stack must satisfy the following requirements::

- It must be constructed from materials that are impermeable to flue gases and that offer lasting resistance to mechanical stress, heat and the action of the products of combustion and condensate
- It must be vertical, free of restrictions and contain bends of no more than 45°
- It must be suitable for the specific operating conditions of the boiler and must be CE marked
- It must be of adequate dimensions to ensure draught and venting properties suitable for the needs of the boiler
- It must have adequate external insulation to prevent condensation and the cooling of flue gases
- the stack must have a dedicated condensate drain system at the bottom.

⚠ The diameter of the smoke duct must never be smaller than the diameter of the flue gas duct of the thermal unit.

⚠ In configuration B23, the stack must guarantee the minimum draught specified by applicable technical standards, assuming zero pressure at the boiler's flue gas exhaust.

2.10.2 Connection to the stack

The boiler must be connected to the stack using rigid flue pipes that are resistant to heat, condensate and mechanical stress. All joints must be sealed and the finished flue must be insulated. Only use materials that are suitable for this purpose, e.g. stainless steel.

The near-horizontal section of flue pipe must have a slope of at least 5° towards the boiler and must also be properly insulated. In long near-horizontal sections of flue pipe (L>1 m), install a condensate drain system near the boiler exhaust (as shown in the figure) to drain off any condensate forming in this section of flue.

The diameter of the stack must always be greater than that of the flue pipe from the boiler's exhaust fitting. To change direction, use a T section with an inspection cap to permit easy access for cleaning inside the pipe. After cleaning, always make sure that inspection caps are replaced tightly and that their seals are undamaged and efficient.

⚠ Flue pipes must maintain a distance of at least 500 mm from flammable or heat sensitive construction materials.

⚠ Joints must be sealed with materials that are resistant to acid condensate and to the high temperatures of the boiler's flue gases.

⚠ When installing flue pipes, always bear in mind the direction of the flue gases and of possible condensate flows.

⚠ Inadequate or badly dimensioned stacks and flues can increase combustion noise, cause condensation problems and affect combustion parameters.

⚠ Uninsulated flues are potentially dangerous and can cause burns.

"OPEN" CONFIGURATION OF THE TYPE B BOILER

The equipment is supplied as standard in type B configuration, hence prepared to suck air directly in the installation room through the venting openings, that must be carried out in compliance with the Technical Standards.

It can become a type C equipment with the use of specific accessories. In this configuration the equipment will suck air directly from the outside with the possibility to have coaxial or split pipes.

Description	INSIEME EVOe 25 B/70 LN	
L _{MAX}	20 (*)	m

(*) This length must be reduced by 1 metre for every 90° curve and by 0.5 metres for every 45° curve.

BOILER CONFIGURATIONS C "SEALED"

If comburent air is drawn from outdoors, the appliances are type C "sealed" and the boiler room does not require ventilation.

Twin pipes (Ø 80 air / Ø 80 flue gases)

For these configurations, the type C transformation accessory must be installed (following the instructions supplied with the accessory itself).

Split ducts can be oriented in the direction most suitable to the room needs, respecting the specified maximum lengths.

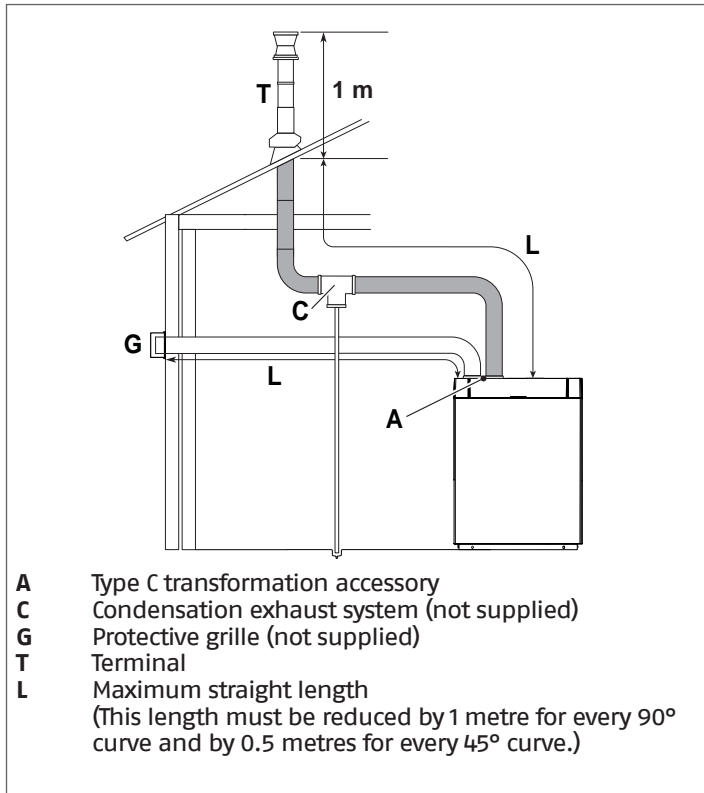

Description	INSIEME EVOe 25 B/70 LN	
L _{MAX} Flue gas vent and comburent air intake	20 (*)	m
L _{MAX} Air inlet	10 (*)	m

(*) This length must be reduced by 1 metre for every 90° curve and by 0.5 metres for every 45° curve.

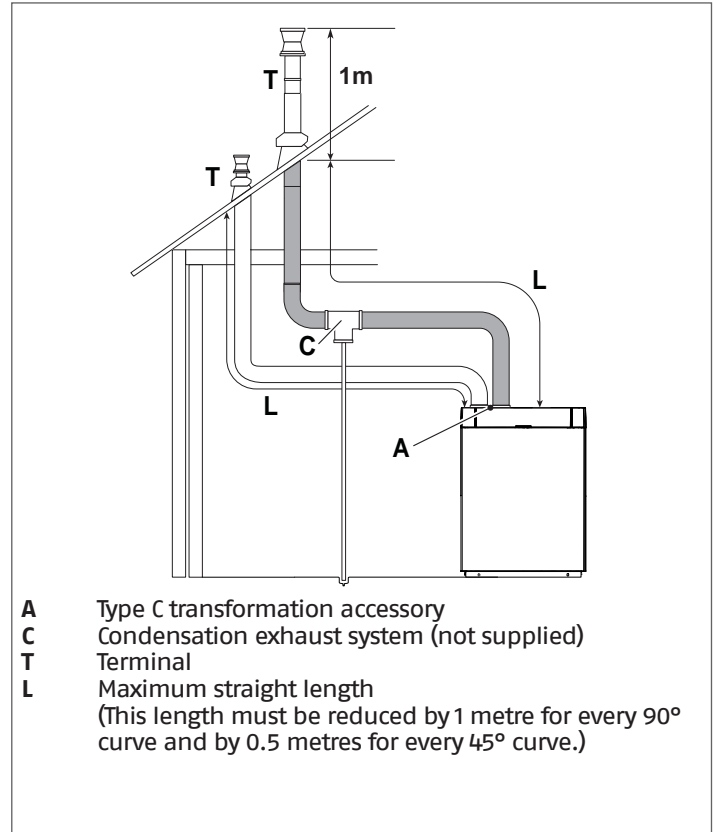

Description	INSIEME EVOe 25 B/70 LN	
L _{MAX} Flue gas vent and comburent air intake	20 (*)	m
L _{MAX} Air inlet	10 (*)	m

(*) This length must be reduced by 1 metre for every 90° curve and by 0.5 metres for every 45° curve.

⚠ Use of flues longer than the specified maximum leads to a loss of heat output from the boiler.

⚠ Never obstruct or choke the comburent air intake pipe.

Coaxial flues (Ø 80/125)

For these configurations, the type C transformation accessory and the concentric flue gas exhaust accessory must be installed (following the instructions supplied with the accessories themselves).

Coaxial flues can be oriented in whatever direction is most convenient for the room, provided the maximum specified lengths are respected.

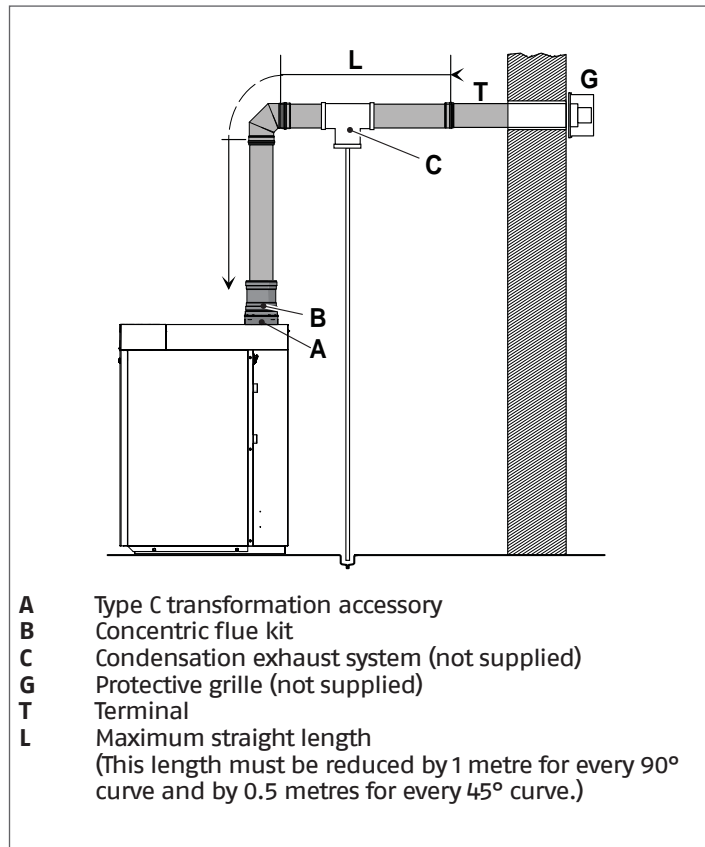

Description	INSIEME EVOe 25 B/70 LN	
L _{MAX}	7 (*)	m

(*) This length must be reduced by 1 metre for every 90° curve and by 0.5 metres for every 45° curve.

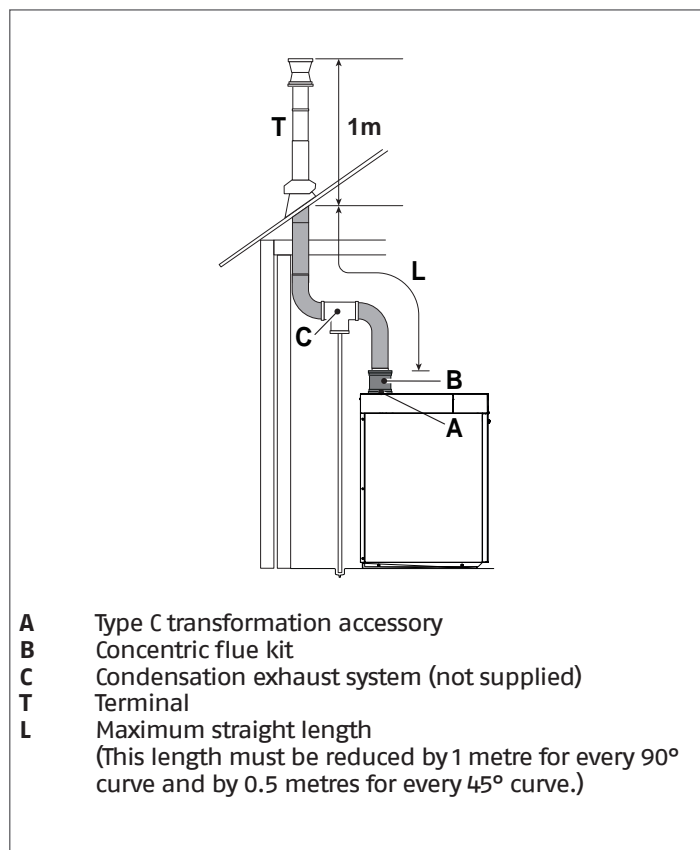

Description	INSIEME EVOe 25 B/70 LN	
L _{MAX}	7 (*)	m

(*) This length must be reduced by 1 metre for every 90° curve and by 0.5 metres for every 45° curve.

⚠ Use of flues longer than the specified maximum leads to a loss of heat output from the boiler.

⚠ Never obstruct or choke the comburent air intake pipe.

⚠ The boilers have been approved with specific roof and wall terminals (Poljoulat). Using different terminals relieves the manufacturer of liability for any issues.

⚠ Maximum air intake temperature 50°C, adjust the values by CO₂ to 12,5% using the air shutter.

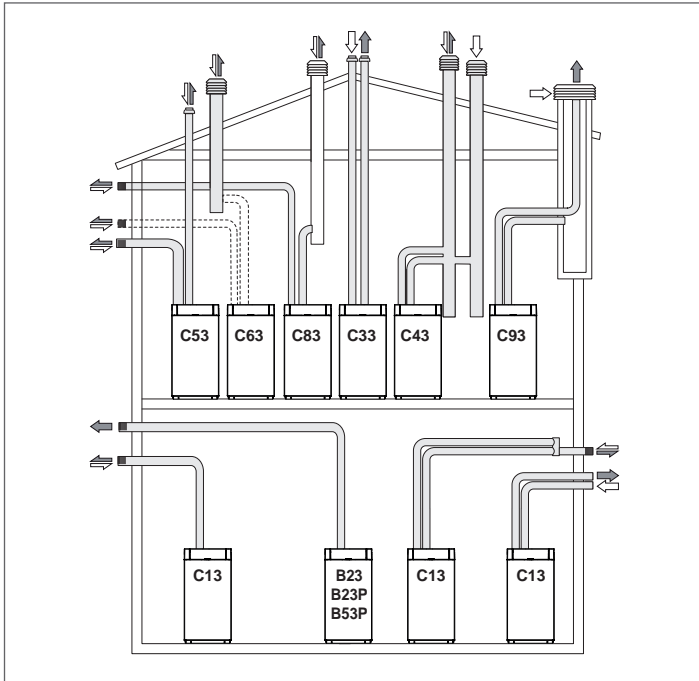

- B23** Upstream fan. Comburent air intake directly from the room where the boiler is installed. Flue gas venting via horizontal or vertical pipes, with air ventilation to room.
- B23P** As B23 but with flue gas vent pipes designed to operate at positive pressure.
- B53P** As for B23P but with flue gas vent pipes supplied by boiler manufacturer.
- C13** Concentric wall vent. Twin flue pipes can also be used, but the wall through-pipes must be concentric or located close enough to be subjected to similar wind conditions.
- C33** Concentric roof vent. Twin flue gas vent pipes may be used, but terminals must be concentric or near enough to be subject to the same wind conditions (i.e. within a 50 cm square with a difference in height between the pipes of less than 50 cm).
- C43** Vent and air intake via separate twin pipes subject to similar wind conditions.
- C53** Separate wall or roof vent and air intake, in areas of different pressure but never on opposite walls.
- C63** Upstream fan. Boiler intended to be connected to a system for the supply of combustion air and for the evacuation of combustion products approved and sold separately. Maximum draught allowed: 200Pa.
- C83** Separate vent and inlet subject to natural draught. Wall air inlet. Vent to individual or shared chimney. Shared chimneys must be insulated to prevent the formation of condensation.

C93 Fan in combustion circuit upstream from the combustion chamber/heat exchanger. This configuration is used in older system upgrades and with condensing boilers. It allows the system to make use of an old air well, chimney or flue that would otherwise be redundant.

- ⚠** See the specific standard for details. In Belgium, see NBN-D51-003.
- ⚠** For B-type installation, combustion air is taken from the environment and goes through the openings (shutters) on the rear panel of the device that must be located in a suitable and ventilated technical room.
- ⚠** Read the requirements, instructions and prohibitions detailed below carefully, since non-compliance with them may be result in a safety hazard or the appliance's malfunction.
- ⚠** Check that pipes and joints are not damaged.
- ⚠** Joint seals must be executed with materials that withstand the condensate's acidity and the temperatures of the appliance's flue gases.
- ⚠** When installing flue pipes, always bear in mind the direction of the flue gases and of possible condensate flows.
- ⚠** Inadequate or incorrectly sized flue gas pipes may increase combustion noise, create condensate extraction issues and negatively impact on combustion parameters.
- ⚠** Check that pipes are suitably far (min. 500 mm) from flammable or heat-sensitive construction elements.
- ⚠** Do not connect the vent flue directly to existing flues used to serve other appliances (cookers, other boilers, etc.). Larger disused flues can nevertheless be used as ducts for routing the boiler's intake and vent flues.
- ⚠** If the vertical section of vent flue is over 4 metres in height, a condensate drain must be provided at its bottom (see paragraph "Preparation for the condensate drain").
- ⊖** It is prohibited to block or section the flue gas extraction pipe or the combustion air suction pipe, if any.
- ⊖** It is prohibited to use pipes that not designed for this application, because the condensate's action would damage them quickly.

2.11 System filling and emptying

The thermal unit **INSIEME EVOe 25 B/70 LN** is equipped with an internal system load valve (1), which can be reached by removing the front panel.

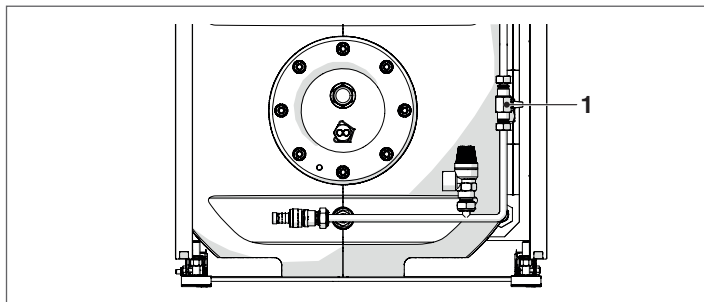

Before performing any system filling or emptying operation, set the system main switch to OFF and the equipment main switch to (0).

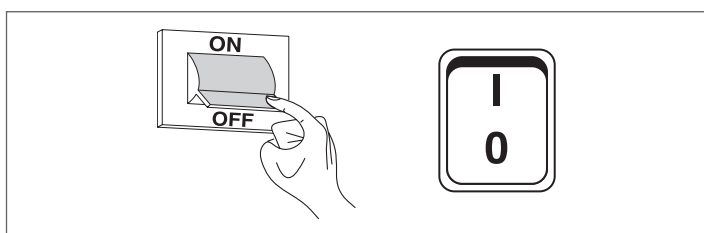

2.11.1 Water quality requirements

The manufacturer recommends the use of water as heat transfer fluid for the central heating system. A chemical treatment system must be provided for this water.

The heat transfer fluid (water) for the central heating circuit must conform to the quality parameters given in the following table:

REFERENCE VALUES	
pH	6-8
Electrical conductivity	less than 200 $\mu\text{S}/\text{cm}$ (25°C)
Chlorine ions	less than 50 ppm
Sulphuric acid ions	less than 50 ppm
Total iron	less than 0.3 ppm
Alkalinity M	less than 50 ppm
Total hardness	less than 35°F
Sulphur ions	none
Ammonia ions	none
Silicon ions	less than 30 ppm

If the hardness of the water exceeds the value specified in the table, it is mandatory to install a water softening system.

⚠ Excessive water softening (leading to a total hardness < 15°F) can cause corrosion in metal parts (pipes and boiler components). Keep the electrical conductivity of the water under 200 $\mu\text{S}/\text{cm}$.

⊖ Do not top up the central heating circuit on a frequent or continuous basis as this can damage the boiler's heat exchanger. The use of automatic topping up systems should be avoided for this reason.

2.11.2 Filling

Before starting, check that:

- The boiler drain (3) and the heater drain (2) valves are closed and that the shut-off valves on the cold water inlet (CWI) are open;

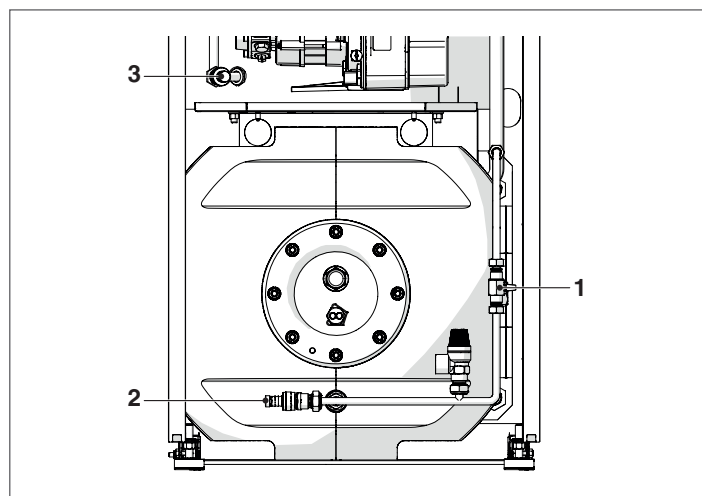

- Open the system load valve (1) and slowly load until the display reaches the water pressure value (cold water) of 1.5 bar



- Close the load valve.

NOTE The system is de-aerated automatically through the automatic vent valve. The drain pipe of the drain valve must be connected to a suitable collection system.

2.11.3 Emptying

Before emptying:

- Set the main switch of the system to OFF and the main switch of the equipment to (0).

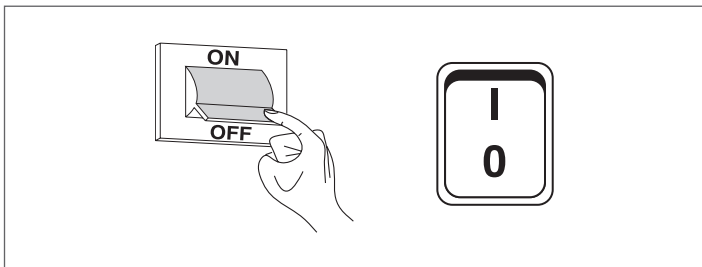

- Close the water supply shut-off cocks;
- To empty the boiler, connect a rubber tube (A) (int \varnothing =12mm) to the hose connector of the boiler drain valve (1) and open it.

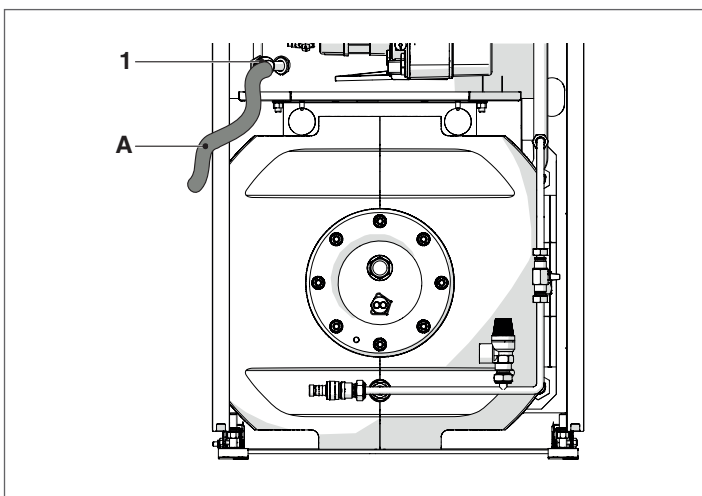

2.11.4 Heater emptying

To empty the heater:

- Make sure that the system load valve (1) is closed;
- Connect a rubber hose (A) (int \varnothing =12mm) to the hose connector of the heater drain valve (2) and open it.

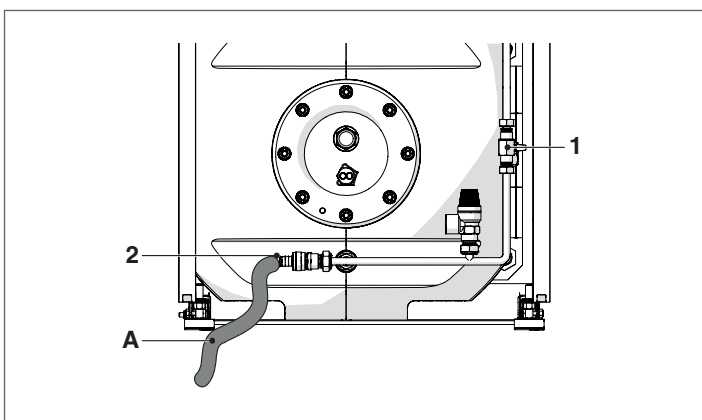

NOTE Open a hot water tap to facilitate emptying the storage cylinder.

2.12 Wiring diagram

Mod. INSIEME EVOe 25 B/70 LN

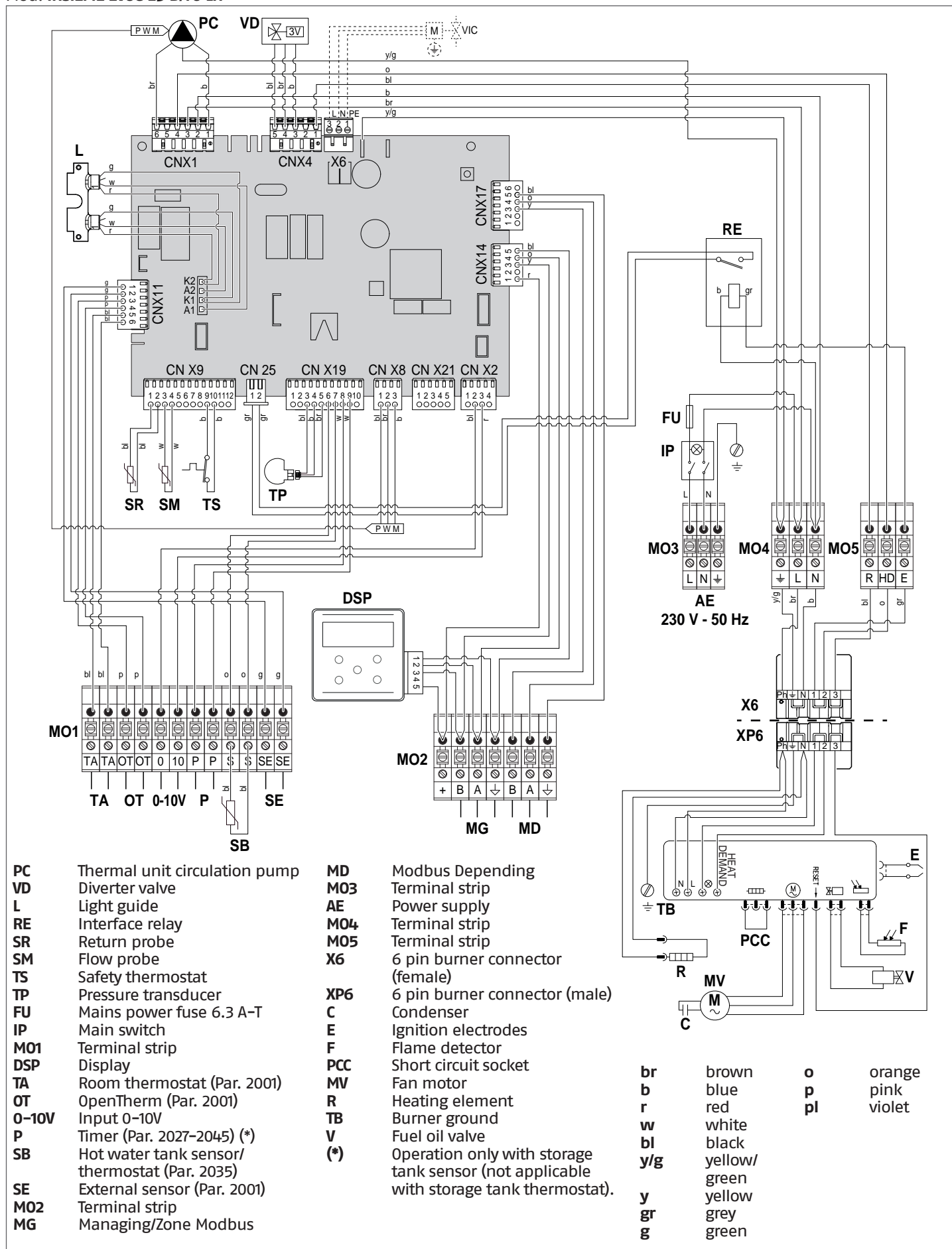

Fuel shut-off valve VIC (not supplied)

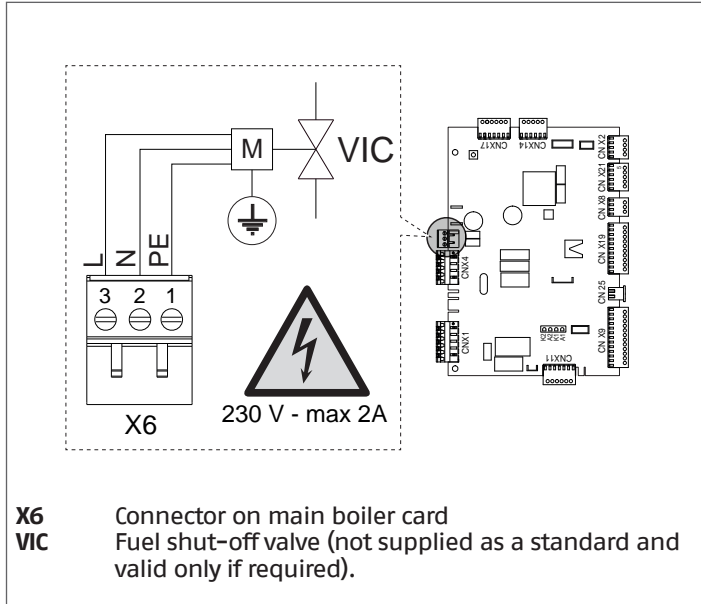

⚠ Check that the value 1 (default) is set at parameter 2030. If the burner's post-ventilation time is changed, a value (in seconds) \geq the value just set on the burner must be set in parameter 2079.

2.13 Electrical connections

The **INSIEME EVOe 25 B/70 LN** boiler is fully cabled in the factory. The only connections required for its installation are those of the mains power supply, room thermostat and other optional system components.

Proceed as follows to access the control panel terminals:

- open the control panel door and remove the fixing screw (2);
- remove the front panel (1) and lift it by pulling it towards yourself;

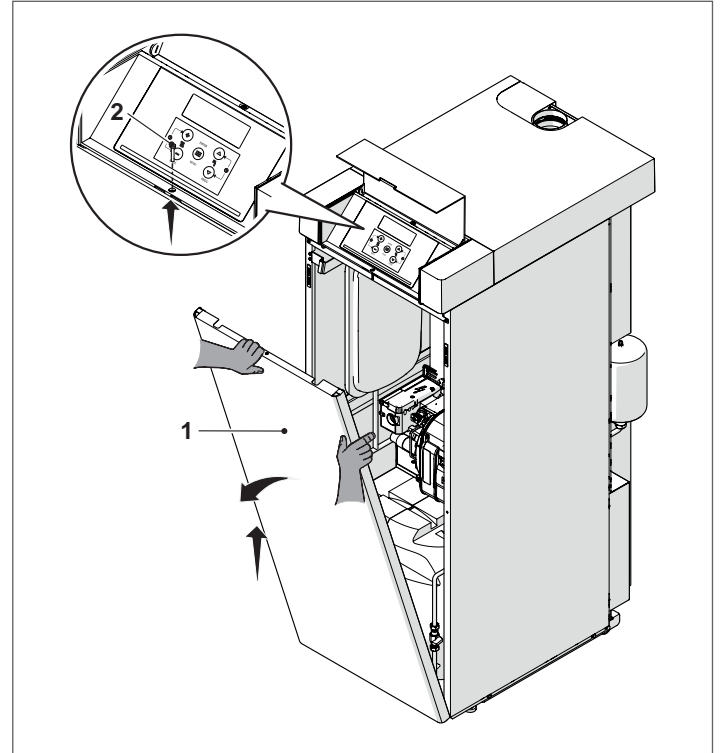

- remove the fixing screw (3) from the top of the control panel;

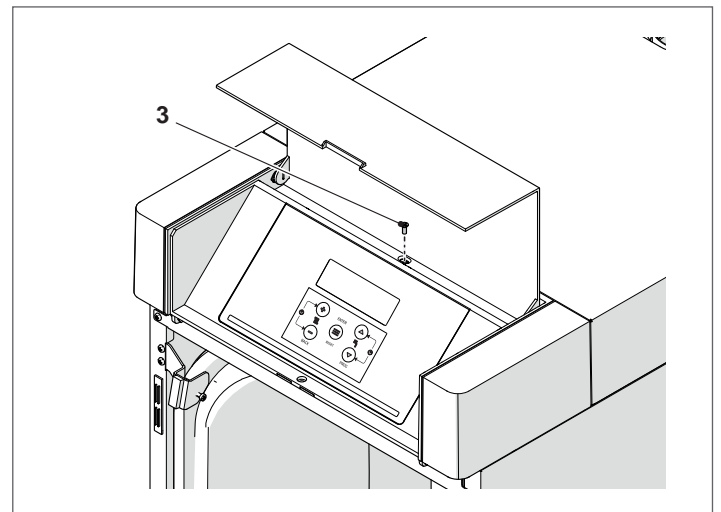

- close the door and turn the control panel outwards;

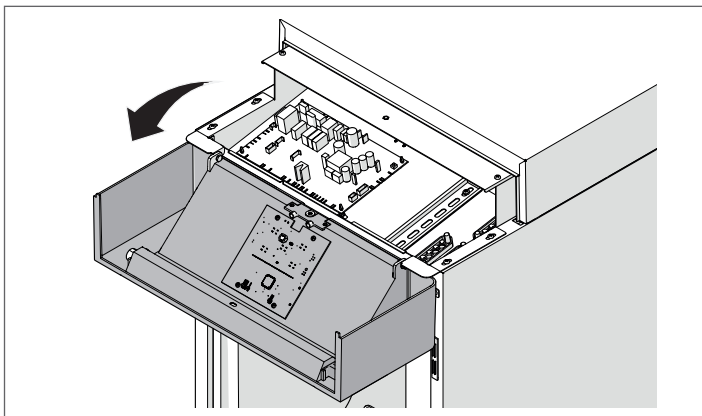

- Lift the upper panel (4) and insert the external connection cables into the preset cable glands (5);

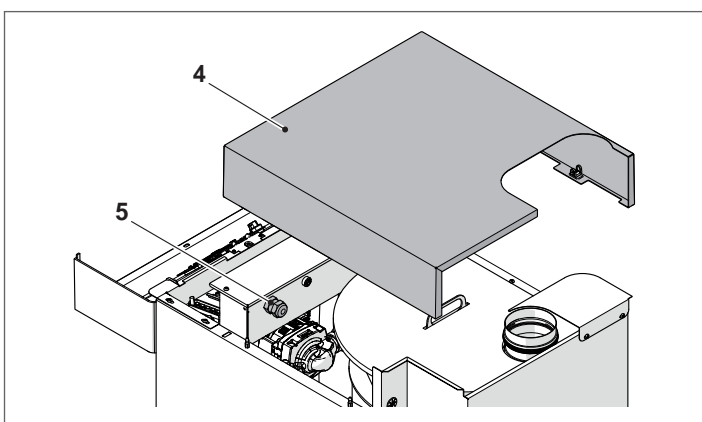

- Make the electrical connections as shown in the following diagrams;

MO1										MO2					MO3				
●	●	●	●	●	●	○	○	●	●	●	●	●	●	●	●	●	●	●	
TA	TA	OT	OT	0	10	P	P	S	SE	+	B	A	↓	B	A	↓	L	N	⊥
TA										MG MD					230 V - 50 Hz				

Connections to be provided by installer

PE Earth/ground
 N Neutral
 L Live
 TA Room thermostat
 MG Managing/Zone Modbus
 MD Modbus Depending

NOTE The room thermostat connection must be dry (no voltage).

- on completion of the electrical connections, replace all removed components in the opposite order.

- ⚠ The following is mandatory:
 - The use of an omnipolar magnetothermic switch, line disconnecting switch in compliance with CEI-EN standards (contact opening of at least 3 mm)
 - Respect the connection L (line) - N (neutral). Keep the earth conductor 2 cm longer than the power supply conductors
 - Use cables with a section greater than or equal to 1.5 mm², complete with cable terminal caps
 - Refer to the wiring diagrams in this manual for all electric operations
 - Connect the equipment to an effective earthing system.

⊖ It is strictly forbidden to use pipes of any kind to ground the appliance.

⊖ It is prohibited to lay power supply and room/heat demand thermostat cables near hot surfaces (delivery pipes). If they may come into contact with parts that have a temperature of over 50°C, use a suitable type of cable.

The manufacturer is not responsible for any damage caused by failure to earth connect the device and failure to comply with what is indicated in the wiring diagrams.

2.14 Menu navigation

At start-up or when no key is pressed for more than 4 minutes, the display is in "basic display" mode and provides general information on the equipment operation.

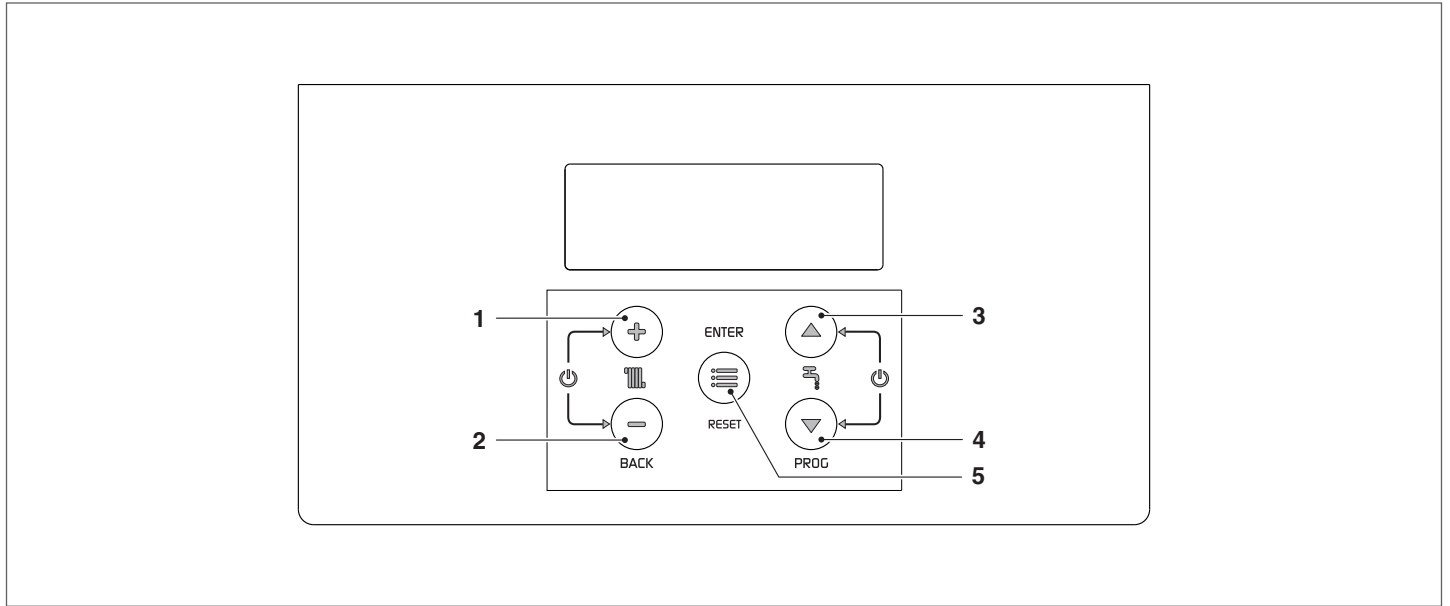

In this mode, keys have the following functions:

Nr.	Button	Function
1	"+"	It increases the heating setpoint (when active/available)
2	"-"	It decreases the heating setpoint (when active/available)
3	"▲"	Raise the DHW set point (when available)
4	"▼"	Decrease the DHW set point (when available)
5	"ENTER/RESET"	Enters into "MENU" mode If pressed for more than 5 seconds, it resets a permanent error (Loc)

Additional functions:

Button	Function
"+" with "-"	It accesses enable/disable heating function mode
"▲" + "▼"	It accesses enable/disable DHW production function mode

For more information, see paragraph "Enable/disable the heating function" on page 45.

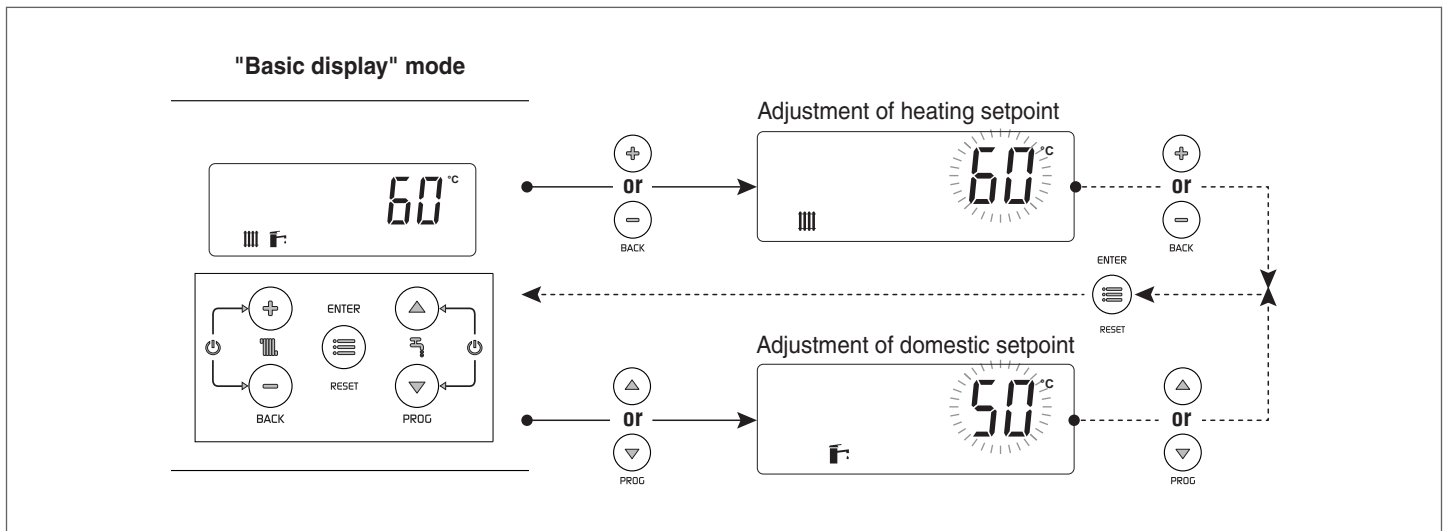

MENU selection

Access the "menu" mode by pressing the key "ENTER/RESET" The digits of the small display indicate "0000", which is the first accessible menu.

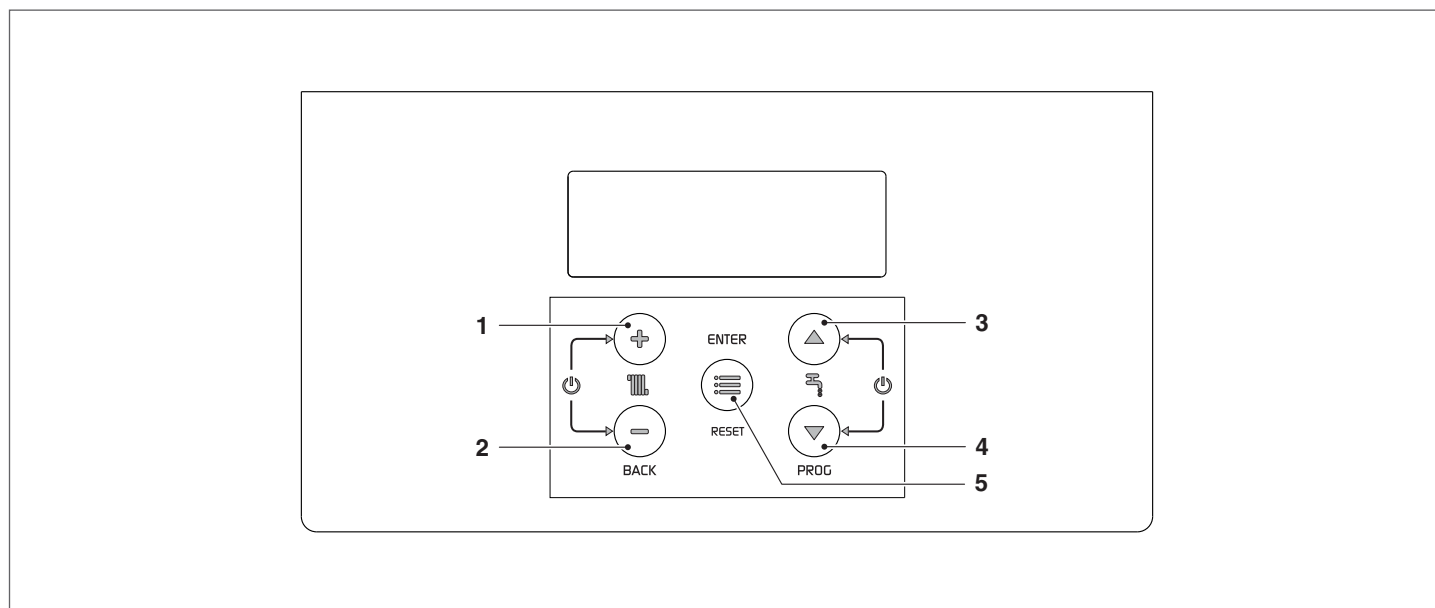

In this mode, keys have the following functions:

Nr.	Button	Function
1	"+"	Exits from the menu and cancels a parameter change
2	"-"	Exits from the menu and cancels a parameter change
3	"▲"	Selects the following menu or increases a certain parameter value
4	"▼"	Selects the previous menu or decreases a certain parameter value
5	"ENTER/RESET"	Enters into the selected menu/parameter or confirms the parameter change

2.15 Enter password

To access INSTALLER parameters, it is necessary to enter the password:

- Press the key "ENTER/RESET" and select "Code" by using the keys "▲" and "▼".

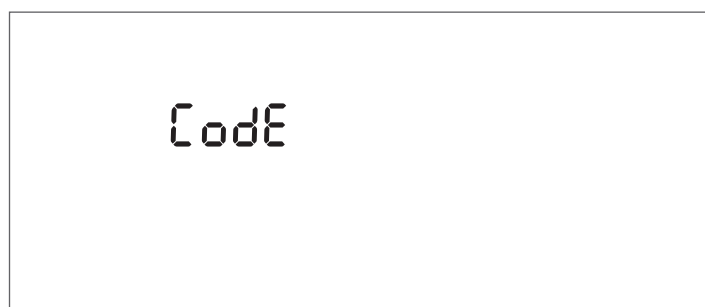

- Press the key "ENTER/RESET" to confirm

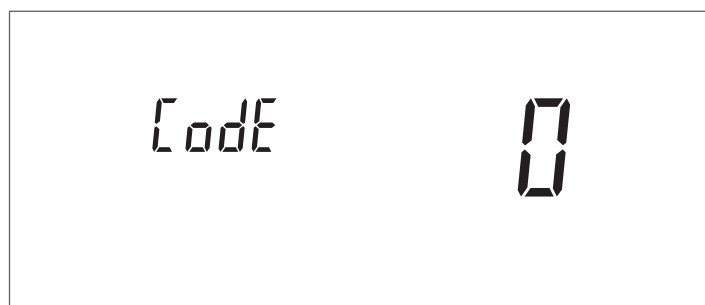

- Press the keys "▲" and "▼" to increase or decrease the value of the blinking digit
- Once the required value is obtained, press the key "ENTER/RESET" to confirm the entered value

After entering the INSTALLER password the relevant menus and parameters will also be displayed.

The system provides for three types of access:

- USER: new password
- INSTALLER: password 18

! After entering the password, the display will show the symbol  which will be displayed until the displaying and/or parametrisation proceed. After some minutes of inactivity of the display, it must be entered again.

2.16 Navigation scheme

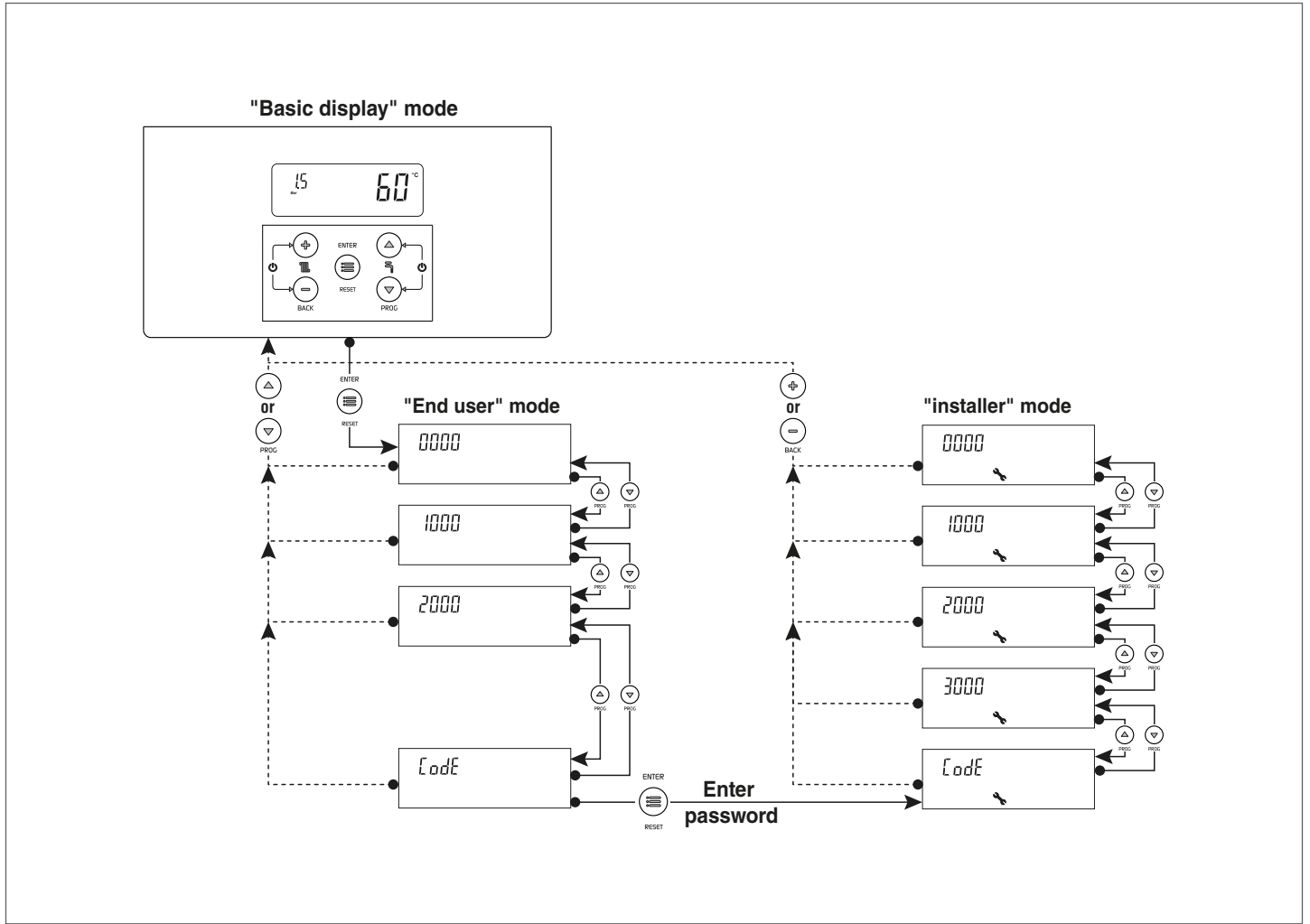

Example of parameter setting

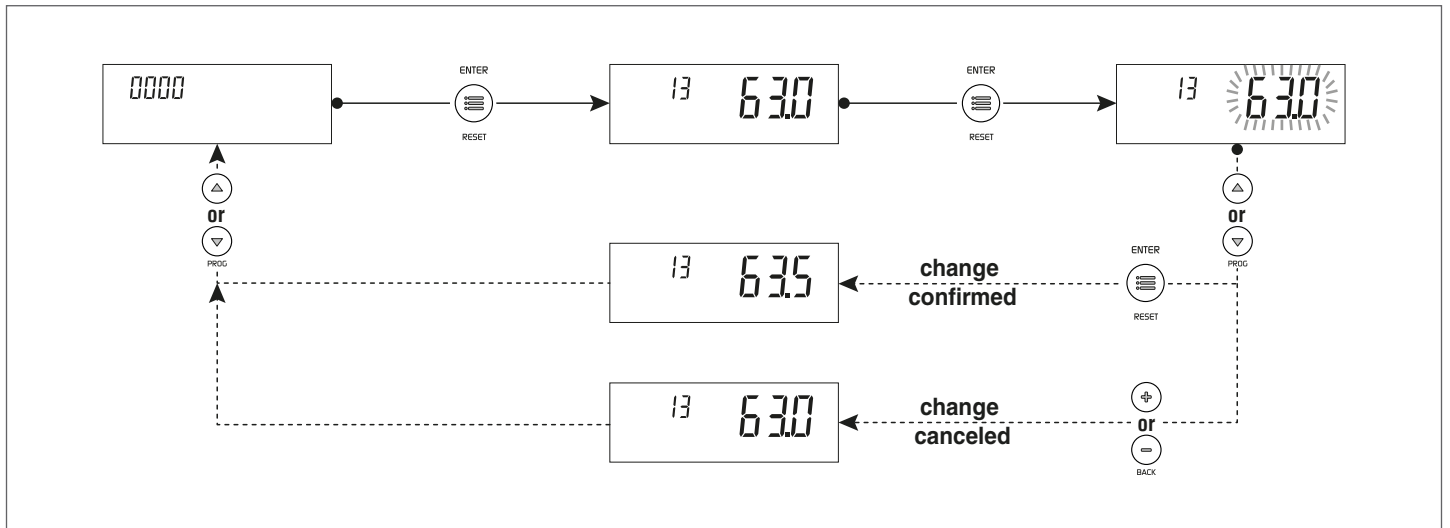

2.17 List of parameters

⚠ The programming lines can be hidden, according to the access level (User, Installer) and to the thermal unit configuration.

Access level:
 U: End user
 I: Installer

⚠ The parameters of Installer level must be changed only by the Technical Assistance Service **RIELLO**.

Key:		SA	Ambient probe
DHW	Domestic hot water	SE	Outdoor sensor
HT	High temperature direct circuit	TA	Room thermostat
BT	Low temperature mixed circuit		
DCW	Domestic cold water		
OT	OpenTherm		

Menu	Par. No.	Description	Range	Default setting INSIEME EVOe 25 B/70 LN	UM	Access
Main menu						
0000	013	Quick adjustment of direct Zone/Zone 1 heating setpoint in 0 and 3 heating modes. By connecting the zone control accessory, this parameter can be used to quickly change direct Zone/Zone 1 setpoint. This parameter simultaneously modifies the value of Par. 2103.	See Par. 2103	See Par. 2103	°C	U
0000	023	Quick adjustment of Zone 2 heating setpoint in 0 and 3 heating modes. By connecting the zone control accessory, this parameter can be used to quickly change Zone 2 setpoint. This parameter simultaneously modifies the value of Par. 2203.	See Par. 2203	See Par. 2203	°C	U
0000	033	Quick adjustment of Zone 3 heating setpoint in 0 and 3 heating modes. By connecting the zone control accessory, this parameter can be used to quickly change Zone 3 setpoint. This parameter simultaneously modifies the value of Par. 2303.	See Par. 2303	See Par. 2303	°C	U
0000	047	Quick adjustment of DHW setpoint with heater This parameter is only visible with Par. 2035 = 1	See Par. 2047		°C	U
0000	048	Quick adjustment of DHW setpoint with instant production This parameter is only visible with Par. 2035 = 10	See Par. 2048		°C	U
0000	200	Test mode 0 = None 1 = Stops the chimney sweep function 2 = Starts the chimney sweep function	0...2	0		I
0000	201	Stops the venting function 0 = No action 1 = Stop venting Visible only when de-aeration is in operation	0...1	0		U
0000	901	Unit of measurement for temperature 0 = °C 1 = °F	0...1	0		I
0000	902	Pressure unit of measurement 0 = BAR 1 = PSI	0...1	0		I
Info menu						
1000	1001	CH flow temperature			°C	U
1000	1002	Domestic hot water temperature			°C	U
1000	1003	Domestic cold water temperature This parameter is only visible with Par. 2035 = 10			°C	U
1000	1004	Outside temperature			°C	U
1000	1007	Return temperature			°C	U
1000	1033	System pressure			bar	U
1000	1056	Total hours of operation in heating mode			h x 10	U
1000	1057	Total hours of operation in domestic mode			h x 10	U
1000	1058	Total hours of operation			h x 10	U

Menu	Par. No.	Description	Range	Default setting INSIEME EVOe 25 B/70 LN	UM	Access
1000	1063	Input signal 0-10V			V	U
1000	1090	Counts down the days to the next service (if it's past, a negative value is shown) If the value is < 15 the service icon flashes			Days	U
1000	1101	Direct Zone/Zone 1 delivery temperature			°C	U
1000	1102	Direct Zone/Zone 1 ambient temperature			°C	U
1000	1112	Zone 1 heating setpoint			°C	U
1000	1201	Zone 2 delivery temperature			°C	U
1000	1202	Zone 2 ambient temperature			°C	U
1000	1212	Zone 2 heating setpoint			°C	U
1000	1301	Zone 3 delivery temperature			°C	U
1000	1302	Zone 3 ambient temperature			°C	U
1000	1312	Zone 3 heating setpoint			°C	U
Heating general settings						
2000	2001	Heating operating mode 0 = Operation with fixed setpoint and ambient thermostat 1 = Operation with climatic curve and ambient thermostat 2 = Continuous operation with climatic curve and night reduction with ambient thermostat 3 = Continuous operation with fixed setpoint and night reduction with ambient thermostat 4 = Operation with variable setpoint with input signal 0-10V	0...4	0		I
2000	2005	Circulator post-circulating time in heating mode	10...900	120	Sec.	I
2000	2007	Switch-off hysteresis in heating mode	0...5	3	°C	I
2000	2008	Ignition hysteresis in heating mode	0...5	3	°C	I
2000	2009	Burner restart time It defines the stand-by time for a subsequent restart after a switch-off, regardless of the delivery temperature decrease. If it goes below the value set in Par. 2010 the thermal unit remains on.	10...900	180	Sec.	I
2000	2010	Temperature differential for burner restart It defines the temperature difference below which the burner restarts regardless of the elapsed time indicated in Par. 2009.	0...20	16	°C	I
2000	2016	Heating pump proportional part PID	0...100	20		I
2000	2017	Heating pump additional part PID	0...600	50		I
2000	2018	Heating pump derivative part PID	0...100	50		I
2000	2019	Function not implemented				I
2000	2020	Function not implemented				I
2000	2021	Number of days to next service		365	Days	U
2000	2022	Service reminder This function reminds the user of the need to carry out a programmed service on the boiler, after the number of days set in Par. 2021 0 = Deactivates the function 1 = Activates the function 2 = Resets the countdown of days to next service to zero	0...2	0		U
2000	2023	Minimum heating setpoint	50, Par. 2024	50	°C	I
2000	2024	Maximum heating setpoint	Par. 2023,90	82	°C	I
2000	2025	Minimum 0-10V input voltage in heating mode Par. 2001= 4	0...10	1	V	I
2000	2026	Maximum 0-10V input voltage in heating mode Par. 2001= 4	0...10	9	V	I
2000	2027	Programmable input 2 0 = Disabled 1= (*) 2= (*) 3= Timer (*) Function not implemented	0...3	0		I

Menu	Par. No.	Description	Range	Default setting INSIEME EVOe 25 B/70 LN	UM	Access
2000	2028	Programmable input 1 0= Disabled 1= Pressure transducer (with temporary or permanent alarm) 2= Pressure transducer (without alarms) (*) (*) Use only when the system is working at low pressure (open tank systems)	0...2	1		I
2000	2029	Function not implemented				I
2000	2030	Programmable output 1 0= Disabled 1= VIC (fuel shut-off valve) relay output on	0...1	1		I
2000	2031	Function not implemented				I
2000	2032	Programmable output 2 0= Disabled 1= 3-way valve with DHW storage tank before the separator 2= 3-way valve with instant DHW version 3= DHW storage tank pump (see label inside boiler electrical panel)	0...3	1		I
2000	2033	Programmable output 4 1= Thermal unit pump 2= System pump	0...2	1		I
2000	2059	Minimum pump modulation value with central heating heat request	0...Par. 2060	40	%	I
2000	2060	Maximum pump modulation value with central heating heat request	Par. 2059...100	100	%	I
2000	2064	Minimum pump modulation value in instant DHW production mode Parameter valid only for thermal units with a plate heat exchanger (IDHW)	0...Par. 2065	40	%	I
2000	2065	Maximum pump modulation value in instant DHW production mode Parameter valid only for thermal units with a plate heat exchanger (IDHW)	Par. 2064...100	100	%	I
2000	2078	Set service hours countdown 0= Burner's hours of operation 1= Boiler's hours of operation	0...1	0		U
2000	2079	Time delay on closing VIC (fuel shut-off valve) When the burner goes off the VIC valve stays open for the time set by this parameter	0...180	60	Sec.	I
2000	2080	Anti-legionella function 0 = deactivated 1 = daily 2 = weekly	0...2	2		I
2000	2088	Function not implemented				I
2000	2090	Venting function 0 = deactivated 1 = activated	0...1	1		I
2000	2091	Number of de-aeration cycles Each cycle includes two ON/OFF sequences, each having 10 seconds ON and 10 seconds OFF. Factory setting anticipates 2 de-aeration cycles every time that the de-aeration function comes on. 1st cycle: the boiler's 3-way diverter valve moves to the central heating position and the boiler pump comes on for 10 seconds, goes off for 10 seconds, comes back on for 10 seconds and then goes off again for 10 seconds. This cycle lasts 40 seconds. 2nd cycle: begins at the end of the 1st cycle. The 3-way diverter valve moves to the DHW position and the pump repeats the same ON/OFF procedures as above, for a total of 40 seconds.	0...255	2		I

Menu	Par. No.	Description	Range	Default setting INSIEME EVOe 25 B/70 LN	UM	Access
2000	2092	Number of repetitions of de-aeration cycles This parameter sets the number of repetitions for each de-aeration cycle set in Par. 2091. The sequence of de-aeration cycles is carried out for the number of times set in this parameter. Based on the factory settings of parameters 2091= 2 and 2092= 10, the total duration of the de-aeration function is 800 seconds (2 cycles of 40 sec. 10 times).	0...255	10		I
2000	2093	Setting use of room thermostat (TA) where there is OpenTherm (OT) connection 0 = Uses only OT communication. The heat request and the setpoint are communicated only via OpenTherm. 1 = Uses room thermostat (TA) to activate heat request and OT to communicate the setpoint requested to the boiler (*). (*) When setting parameter = 1 in a central heating system managed with zone valves, where there is an OT room thermostat for each valve, the OT room thermostat will control the opening and closing of the respective valve (zone) and the valve microswitch, connected to terminal TA of the boiler, will control (ON/OFF) the heat request. If both requests (OT and TA) are active, the OT request will be fulfilled.	0...1	0		I
Direct Zone / Zone 1 Heating Settings						
2000	2103	Direct Zone/Zone 1 setpoint in heating mode Par. 2001= 0 and 3 The thermal unit adjustment determines the boiler setpoint in heating mode, using the highest value among the requests of all the active zones (Par. 1101, 1201, 1301) If Zone 1 is configured as mixed, the value set in parameter 1112 will be used as setpoint	If Zone 1 is not enabled: (Par. 2121, Par. 2024) If Zone 1 is enabled: BT: (Par. 2121, 45) AT: (Par. 2121, Par. 2024)	70 (AT) 45 (BT)	°C	U
2000	2119	Direct Zone/Zone 1 heating setpoint at the minimum external temperature The range of this parameter is limited to the values of Minimum (Par. 2023) and Maximum (Par. 2024) setpoints.	If Zone 1 is not enabled: (Par. 2121, Par. 2024) If Zone 1 is enabled: BT: (Par. 2121, 45) AT: (Par. 2121, Par. 2024)	82 (AT) 45 (BT)	°C	I
2000	2120	Direct Zone/Zone 1 minimum external temperature It defines the minimum external temperature to which the heating maximum setpoint in Par. 2119 must be associated	-20...5	-20	°C	I
2000	2121	Direct Zone/Zone 1 heating setpoint at the maximum external temperature (Par. 2122) It sets the minimum heating setpoint when the external temperature is equal to the value set in parameter 2122 (basic external temperature)	If Zone 1 is not enabled: (Par. 2023, Par. 2119) If Zone 1 is enabled: BT: (20, Par. 2119) AT: (Par. 2023, Par. 2119)	30 (AT) 20 (BT)	°C	I
2000	2122	Direct Zone/Zone 1 maximum external temperature It sets the external temperature at which the boiler setpoint must be reduced, according to the value defined in parameter 2121	5...30	20	°C	I
2000	2125	Direct Zone/Zone 1 summer/winter switching It stops the request in heating mode when the external temperature is higher than this setpoint	0...35	20	°C	I
2000	2130	Parallel shift of direct Zone/Zone 1 climatic curve	-10...10	0	°C	U
2000	2131	Direct Zone/Zone 1 mild climate temperature compensation	0...20	0	°C	I
2000	2132	Direct Zone/Zone 1 ambient temperature nominal value When an OpenTherm (OT) ambient thermostat is connected to the thermal unit or to the zone control accessory, this parameter is not displayed	5...35	20	°C	I

Menu	Par. No.	Description	Range	Default setting INSIEME EVOe 25 B/70 LN	UM	Access
2000	2133	Direct Zone/Zone 1 setpoint night reduction in heating mode Par. 2001= 2 or 3 It defines by how many degrees the heating setpoint will be reduced at the opening of the ambient thermostat (AT) contact The reduction of the delivery temperature affects all the active heating zones and it can be used when the AT terminal of every zone regulator is jumpered.	0...10	4	°C	I
2000	2134	Compensation factor of direct Zone/Zone 1 external temperature	0...100	50	%	I
2000	2135	Zone 1 mixing valve closing time	0...240	140	Sec.	I
2000	2136	Zone 1 mixing valve PID P	0...99	5		I
2000	2137	Zone 1 mixing valve PID I	0...99	10		I
2000	2138	Zone 1 valve operating time	0...255	2	Sec. x 10	I
2000	2139	Zone 1 setpoint increase Increases the value of the heating zone setpoint. For example, if the zone setpoint is 40°C, the heat request sent to the boiler will be increased by 5°C (factory setting), therefore the value requested at the boiler will be 45°C. Valid only for mixed zone.	0...20	5	°C	I
2000	2140	Zone 1 circulator post-circulating time	0...240	30	Sec.	I
2000	2141	Zone 1 delivery overtemperature protection	0...100	55	°C	I
2000	2142	Zone 1 overtemperature control time	0...240	0	Min.	I
2000	2143	Zone 1 overtemperature stand-by time	0...240	2	Min.	I
2000	2144	Zone 1 system reset time	0...240	2	Min.	I
2000	2500	Function not implemented				I
2000	2501	Function not implemented				I
3000	3100	Use of Zone 1 control accessory 0 = NO 1 = Yes If Zone 1 control accessory is used, AT and AP inputs are not enabled. AT input is used only to enable the night reduction on all the active zones (Par. 2001 = 2 and 3)	0...1	0		I
3000	3101	Zone 1 mode 0 = direct 1 = mixed	0...1	0		I
Zone 2 Heating Settings						
2000	2203	Zone 2 heating setpoint in 0 and 3 heating modes The thermal unit adjustment determines the boiler setpoint in heating mode, using the highest value among the requests of all the active zones (Par. 1101, 1201, 1301) If Zone 2 is set as mixed, the value set in parameter 1212 will be used as the setpoint.	BT: (Par. 2221, 45) AT: (Par. 2221, Par. 2024)	70 (AT) 45 (BT)	°C	U
2000	2219	Zone 2 maximum heating setpoint at the minimum external temperature The range of this parameter is limited to the values of Minimum (Par. 2023) and Maximum (Par. 2024) setpoints.	BT: (Par. 2221, 45) AT: (Par. 2221, Par. 2024)	82 (AT) 45 (BT)	°C	I
2000	2220	Zone 2 minimum external temperature It defines the minimum external temperature to which the maximum heating setpoint Par. 2219 must be associated.	-20...5	-20	°C	I
2000	2221	Zone 2 minimum heating setpoint at basic external temperature (Par. 2222) It sets the minimum heating setpoint when the external temperature is equal to the value set in parameter 2222 (basic external temperature).	BT: (20, Par. 2219) AT: (Par. 2023, Par. 2219)	30 (AT) 20 (BT)	°C	I
2000	2222	Zone 2 basic external temperature It sets the external temperature at which the boiler setpoint must be reduced, according to the value defined in parameter 2221.	5...30	20	°C	I

Menu	Par. No.	Description	Range	Default setting INSIEME EVOe 25 B/70 LN	UM	Access
2000	2225	Zone 2 summer/winter switching It blocks the heating request when the external temperature is greater than this setpoint.	0...35	20	°C	I
2000	2230	Parallel shift of direct Zone/Zone 1 climatic curve	-10...10	0	°C	U
2000	2231	Zone 2 mild climate temperature compensation	0...20	0	°C	I
2000	2232	Zone 2 ambient temperature nominal value When an OpenTherm (OT) ambient thermostat is connected to the zone control accessory, this parameter is not used.	5...35	20	°C	I
2000	2233	Zone 2 setpoint night reduction in heating mode (Par. 2001= 2 or 3) It defines by how many degrees the heating setpoint will be reduced at the opening of the ambient thermostat (AT) contact The reduction of the delivery temperature affects all the active heating zones and it can be used when the AT terminal of every zone regulator is jumpered.	0...10	4	°C	I
2000	2234	Compensation factor of Zone 2 external temperature	0...100	50	%	I
2000	2235	Zone 2 mixing valve closing time	0...240	140	Sec.	I
2000	2236	Zone 2 mixing valve PID P	0...99	5		I
2000	2237	Zone 2 mixing valve PID I	0...99	10		I
2000	2238	Zone 2 valve operating time	0...255	2	Sec. x 10	I
2000	2239	Zone 2 setpoint increase Increases the value of the heating zone setpoint. For example, if the zone setpoint is 40°C, the heat request sent to the boiler will be increased by 5°C (factory setting), therefore the value requested at the boiler will be 45°C. Valid only for mixed zone.	0...20	5	°C	I
2000	2240	Zone 2 circulator post-circulating time	0...240	30	Sec.	I
2000	2241	Zone 2 delivery overtemperature protection	0...100	55	°C	I
2000	2242	Zone 2 overtemperature control time	0...240	0	Min.	I
2000	2243	Zone 2 overtemperature stand-by time	0...240	2	Min.	I
2000	2244	Zone 2 system reset time	0...240	2	Min.	I
3000	3200	Use of Zone 2 control accessory 0 = NO 1 = Yes If Zone 2 control accessory is used, AT and OT inputs are not enabled. AT input is used only to enable the night reduction on all the active zones (Par. 2001= 2 and 3)	0...1	0		I
3000	3201	Zone 2 mode 0 = direct 1 = mixed	0...1	0		I
Zone 3 Heating Settings						
2000	2303	Zone 3 heating setpoint in 0 and 3 heating modes The thermal unit adjustment determines the boiler setpoint in heating mode, using the highest value among the requests of all the active zones (Par. 1101, 1201, 1301) If Zone 3 is set as mixed, the value set in parameter 1312 will be used as the setpoint.	BT: (Par. 2321, 45) AT: (Par. 2321, Par. 2024)	70 (AT) 45 (BT)	°C	U
2000	2319	Zone 3 maximum heating setpoint at the minimum external temperature The range of this parameter is limited to the values of Minimum (Par. 2023) and Maximum (Par. 2024) setpoints.	BT: (Par. 2321, 45) AT: (Par. 2321, Par. 2024)	82 (AT) 45 (BT)	°C	I
2000	2320	Zone 3 minimum external temperature It defines the minimum external temperature to which the maximum heating setpoint Par. 2319 must be associated.	-20...5	-20	°C	I
2000	2321	Zone 3 minimum heating setpoint at basic external temperature (Par. 2322) It sets the minimum heating setpoint when the external temperature is equal to the value set in parameter 2322 (basic external temperature).	BT: (20, Par. 2319) AT: (Par. 2023, Par. 2319)	30 (AT) 20 (BT)	°C	I

Menu	Par. No.	Description	Range	Default setting INSIEME EVOe 25 B/70 LN	UM	Access
2000	2322	Zone 3 basic external temperature It sets the external temperature at which the boiler setpoint must be reduced, according to the value defined in parameter 2321.	5...30	20	°C	I
2000	2325	Zone 3 summer/winter switching It blocks the heating request when the external temperature is greater than this setpoint.	0...35	20	°C	I
2000	2330	Parallel shift of direct Zone/Zone 1 climatic curve	-10...10	0	°C	U
2000	2331	Zone 3 mild climate temperature compensation	0...20	0	°C	I
2000	2332	Zone 3 ambient temperature nominal value When an OpenTherm (OT) ambient thermostat is connected to the zone control accessory, this parameter is not used.	5...35	20	°C	I
2000	2333	Zone 3 setpoint night reduction in heating mode (Par. 2001 = 2 or 3) It defines by how many degrees the heating setpoint will be reduced at the opening of the ambient thermostat (AT) contact The reduction of the delivery temperature affects all the active heating zones and it can be used when the AT terminal of every zone regulator is jumpered	0...10	4	°C	I
2000	2334	Compensation factor of Zone 3 external temperature	0...100	50	%	I
2000	2335	Zone 3 mixing valve closing time	0...240	140	Sec.	I
2000	2336	Zone 3 mixing valve PID P	0...99	5		I
2000	2337	Zone 3 mixing valve PID I	0...99	10		I
2000	2338	Zone 3 valve operating time	0...255	2	Sec. x 10	I
2000	2339	Zone 3 setpoint increase Increases the value of the central heating zone setpoint. For example, if the zone setpoint is 40°C, the heat request sent to the boiler will be increased by 5°C (factory setting), therefore the value requested from for the boiler will be 45°C. Valid only for mixed zone.	0...20	5	°C	I
2000	2340	Zone 3 circulator post-circulating time	0...240	30	Sec.	I
2000	2341	Zone 3 delivery overtemperature protection	0...100	55	°C	I
2000	2342	Zone 3 overtemperature control time	0...240	0	Min.	I
2000	2343	Zone 3 overtemperature stand-by time	0...240	2	Min.	I
2000	2344	Zone 3 system reset time	0...240	2	Min.	I
3000	3300	Use of Zone 3 control accessory 0 = NO 1 = Yes If Zone 3 control accessory is used, AT and OT inputs are not enabled. AT input is used only to enable the night reduction on all the active zones (Par. 2001 = 2 and 3).	0...1	0		I
3000	3301	Zone 3 mode 0 = direct 1 = mixed	0...1	0		I
DHW settings and system configuration						
2000	2035	Domestic operating mode 0 = DHW disabled 1 = DHW with heater 10 = DHW instant production	0...10	1		I
2000	2036	Hysteresis for heater DHW request start If the heater temperature goes below the DHW setpoint minus the hysteresis value defined in this parameter, the regulator confirms the fulfilment of the request.	0...5	3	°C	I
2000	2037	Hysteresis for heater DHW request stop If the heater temperature goes above the DHW setpoint plus the hysteresis value defined in this parameter, the regulator confirms the stop of the request.	0...5	3	°C	I
2000	2038	Thermal unit delivery temperature increase in DHW mode with heater It increases the delivery temperature to the boiler by the value set in this parameter.	0...20	15	°C	I

Menu	Par. No.	Description	Range	Default setting INSIEME EVOe 25 B/70 LN	UM	Access
2000	2041	Primary setpoint for heater with thermostat	50...82	75	°C	I
2000	2042	Heat request priority 0 = DHW has priority over heating during the time set in Par. 2043. 1 = Heating mode priority 2 = Domestic mode priority 3 = Parallel	0...3	2		I
2000	2043	Time for which the priority is alternately assigned to domestic and heating circuits when the Par. 2042 is set to "0" mode (for heater only).	0...120	60	Min.	I
2000	2044	Circulator post-circulating time in domestic mode.	10...900	120	Sec.	I
2000	2045	Enabling DHW timer input for storage tank 0 = DHW always enabled 1 = DHW enabled by timer (*) Not applicable with storage tank thermostat. (*) To turn on the timer set Par. 2027 = 3 and Par. 2045 = 1.	0...1	0		I
2000	2047	DHW setpoint with heater This parameter is only visible with Par. 2035 = 1	40...65	57	°C	U
2000	2048	DHW setpoint with instant production This parameter is only visible with Par. 2035 = 10	40...70	45	°C	U
2000	2052	DCW minimum temperature setpoint of DHW exchanger (it activates pump and diverting valve on domestic circuit) Parameter valid only for thermal units with a plate heat exchanger (IDHW)	10...35	25	°C	I
2000	2053	DCW maximum temperature setpoint of DHW exchanger (it deactivates pump and diverting valve on domestic circuit) Parameter valid only for thermal units with a plate heat exchanger (IDHW)	10...43	25	°C	I
2000	2056	Boiler minimum holding temperature for DHW instant production This parameter is only visible with Par. 2035 = 10	20...82	60	°C	I
2000	2061	Boiler shutdown threshold when producing instant DHW. Temperature refers to delivery sensor Parameter valid only for thermal units with a plate heat exchanger (IDHW)	40...82	80	°C	I
2000	2062	Upper temperature hysteresis above the boiler shutdown threshold when producing instant DHW (Par. 2061) Parameter valid only for thermal units with a plate heat exchanger (IDHW)	0...3	1	°C	I
2000	2063	ΔT boiler delivery / boiler return Parameter valid only for thermal units with a plate heat exchanger (IDHW)	5...40	15	°C	I
2000	2074	Burner anti-freeze protection 0 = NO 1 = Yes	0...1	1		I
2000	2075	Heating circuit anti-freeze protection 0 = Disabled 1 = Always on (an external sensor must be installed) 2 = Activates with the heating ON. If the heating is turned off (summertime) the antifreeze protection does not come on	0...2	0		I
2000	2076	DHW anti-freeze protection 0 = NO 1 = YES	0...1	1		I
2000	2077	DHW anti-freeze protection time	0...24	12	Hours	I
2000	2099	Burner ignition stand-by time It delays the burner ignition after the opening of the solenoid valve on the fuel supply pipeline	0...60	0	Sec.	I
Error log						
9000	9001	Error log - 1	0...9999			U
9000	9002	Error log - 2	0...9999			U
9000	9003	Error log - 3	0...9999			U
9000	9004	Error log - 4	0...9999			U

Menu	Par. No.	Description	Range	Default setting INSIEME EVOe 25 B/70 LN	UM	Access
9000	9005	Error log - 5	0...9999			U
9000	9006	Error log - 6	0...9999			U
9000	9007	Error log - 7	0...9999			U
9000	9008	Error log - 8	0...9999			U
9000	9009	Error log - 9	0...9999			U
9000	9010	Error log - 10	0...9999			U

3 COMMISSIONING AND MAINTENANCE

3.1 Preparing for initial startup

The first start-up of the thermal unit must be carried out by the Technical Assistance Service.

Perform the following checks before starting up the boiler:

- Check that the fuel shut-off cock and heating system shut-off cock are open

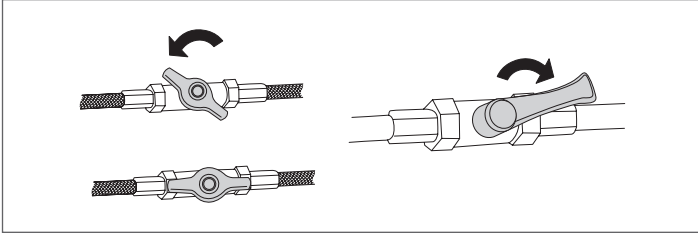

- the pressure of the hydraulic circuit, with cold water, is **1.5 bar** (value indicated on the first screen of the control panel display) and the circuit is not vented

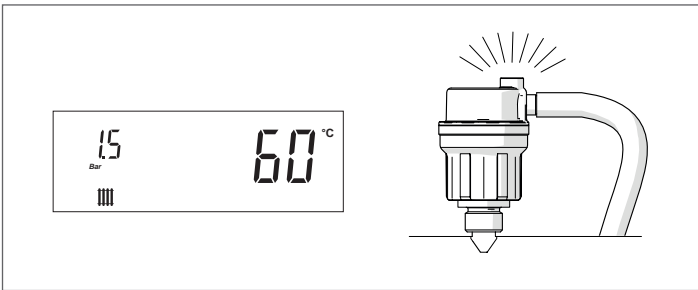

- Check that the expansion vessel is correctly pre-charged
- the electric connections have been made correctly
- Check that the flue and air vents are made to applicable laws and standards.

3.2 Initial startup

Once you have completed all the checks listed above, proceed as follows to start up the boiler for the first time:

- set the main switch of the system to ON and the main switch of the equipment to (I).

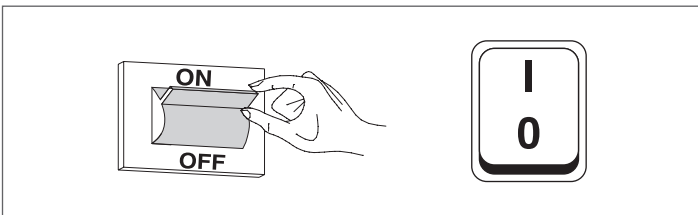

Upon switching on, the display of the control interface of the device shows the following pages in sequence.

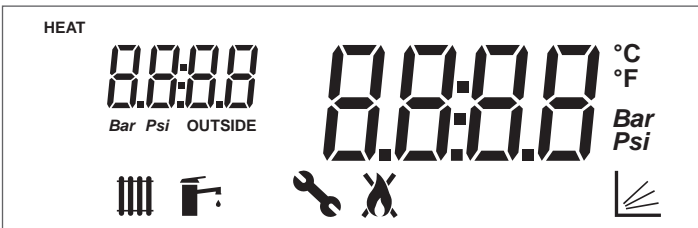

Firmware version of the thermal unit interface.

In the example the message indicates a firmware version = 0.

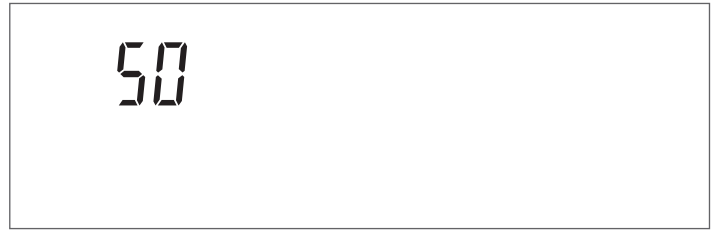

Communication test between interface and regulator.

The message "init" will appear briefly to indicate the beginning of the communication between the interface and regulator inside the thermal unit (*)



Firmware version of the thermal unit regulator.

In the example the message indicates a firmware version = 1.





At first start-up and at every restoration of the power supply the venting function signalled by the message "Air" activates. The vent cycle lasts 14 minutes.



(*) If the communication test fails the message "no COMM" will appear



Once the initialization phase is complete, the display switches to "basic display" mode.

In this mode, the main information on the equipment operation is displayed. The meaning of the different icons displayed is explained in paragraph "Control panel". The icon  and the heating delivery temperature are displayed, either if the boiler is in stand-by mode or if a temperature request is active (icon  blinking).

To switch off the equipment, set the main switch to "0".

⚠ Never power off the appliance before switching the master switch to the "0" position.

⚠ Never switch off the appliance with the master switch if a request is active. Always make sure that the appliance is in stand-by before switching the main switch.

Example of generator stand-by display in heating only mode (external probe not connected)



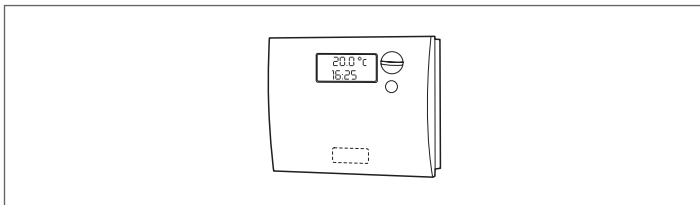

- Set the room thermostat to the required temperature (~ 20°C) or, if the system has a timer or timer-thermostat, make sure that this is switched "ON" and adjusted to the required temperature (~ 20°C);



3.2.1 Adjustment of heating setpoint

- Press the key "+" or "-" to display the current value of the heating temperature setpoint.



- Increase or decrease the setpoint according to the type of system by using the key "+" or "-".
- To save the modification made and go back to the initial screen, wait for 3 seconds or press the key "ENTER/RESET".
- Check that the thermal unit starts the ignition phase and that the display shows the icon  blinking (ambient heating request) and the icon .
- The boiler now starts up and the burner remains lit until the temperature setpoint is reached.

3.2.2 Enable/disable the heating function

- Press the keys "+" and "-" simultaneously for a few seconds;
- The icon  and the current heating mode (ON or OFF) will blink on the display;



- Press the keys "+" and "-" to select the required mode;
- Press the key "ENTER/RESET" or wait for 3 seconds to save the modification made and go back to the initial screen.

3.2.3 Adjustment of domestic setpoint

- Press the key "▲" or "▼" to display the current value of domestic setpoint.



- Increase or decrease the setpoint by using the key "▲" or "▼".
- To save the modification made and go back to the initial screen, press the key "ENTER/RESET".

3.2.4 Enable/disable the domestic function

- Press the keys "▲" and "▼" simultaneously for a few seconds;
- The icon  and the current domestic mode (ON or OFF) will blink on the display;

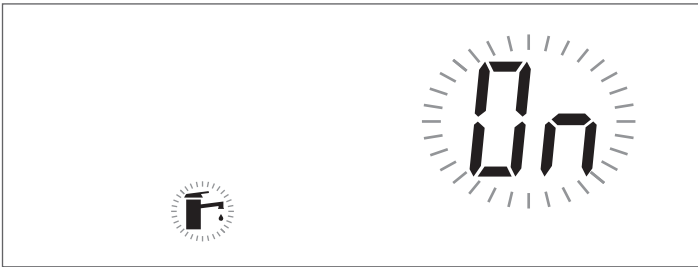

- Press the keys "▲" and "▼" to select the required mode;
- To save the modification made and go back to the initial screen, press the key "ENTER/RESET".

3.2.5 Setting the heating parameters

The thermoregulation on the thermal unit uses pre-configurations which allow to simplify the first start-up operations. There are five boiler operating modes in heating mode (Par. 2001). The basic configuration of the parameter 2001 is 0. The parameters to be set on the regulator will vary according to the selected operating mode.

Mode 0: operation with ambient thermostat (AT)/heat request

In this mode:

- External probe is not required.
- The OpenTherm (OT) communication is not enabled and any OT thermostat connected is supplied but signals a "communication error".
- Input 0-10V is not used.
- The Modbus communication is enabled. If a device is connected to the Modbus, the zone regulator works in priority to the ambient thermostat (AT/OT).

The thermal unit thermoregulation manages the heating delivery temperature with a fixed setpoint defined in Par. 2103. The setpoint value can be directly set, without having to access the list of parameters as indicated in paragraph "Menu navigation" on page 32.

The setpoint can be set within a range defined by par. 2023 (minimum) and 2024 (maximum) as indicated in the figure.

The parameters regulating such temperature are:

Par. No.	Description
2103	Main Zone/Zone 1 setpoint in heating mode Par. 2001 = 0 and 3. The thermal unit adjustment determines the boiler setpoint in heating mode, using the highest value among the requests of all the active zones (Par. 1101, 1201, 1301). If Zone 1 is set as mixed, the value set in parameter 1112 will be used as setpoint.
2023	Minimum heating setpoint.
2024	Maximum heating setpoint

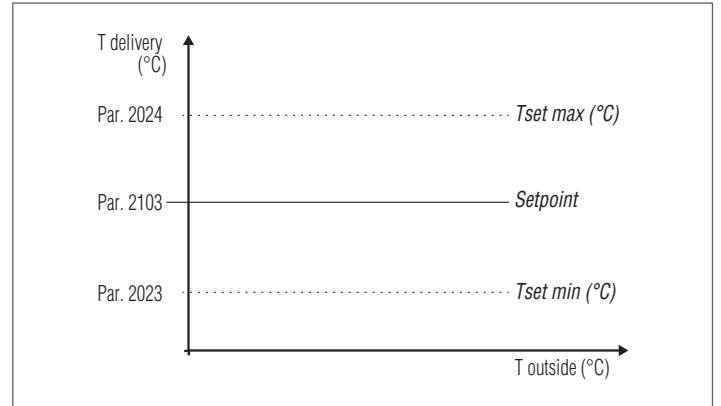

Mode 1: Operation with ambient thermostat (AT/OT) heat request and external probe (accessory)

Display on climatic mode



In this mode:

- The external probe (accessory) is necessary to enable the thermal unit operation. The icon **OUTSIDE** is displayed. In this case the heating setpoint can no longer be manually changed, but is calculated by the regulator.
- The Open Therm (OT) communication is enabled.
- Input 0-10V is not used.
- The Modbus communication is enabled. If a device is connected to the Modbus, the zone regulator works in priority to the ambient thermostat (AT/OT).

The heating delivery temperature is defined by a setpoint which varies according to the external temperature and the ambient temperature on the basis of a climatic curve defined by the following parameters:

Par. No.	Description
2023	Minimum heating setpoint
2024	Maximum heating setpoint
2119	Direct Zone/Zone 1 heating setpoint at the minimum external temperature The range of this parameter is limited to the values of Minimum (Par. 2023) and Maximum (Par. 2024) setpoints.
2120	Direct Zone/Zone 1 minimum external temperature It defines the minimum external temperature to which the heating maximum setpoint in Par. 2119 must be associated
2121	Direct Zone/Zone 1 heating setpoint at the maximum external temperature (Par. 2122) It sets the minimum heating setpoint when the external temperature is equal to the value set in parameter 2122 (basic external temperature)
2122	Direct Zone/Zone 1 maximum external temperature It sets the external temperature at which the boiler setpoint must be reduced, according to the value defined in parameter 2121
2125	Direct Zone/Zone 1 summer/winter switching It stops the request in heating mode when the external temperature is higher than this setpoint
2130	Parallel shift of direct Zone/Zone 1 climatic curve
2131	Direct Zone/Zone 1 mild climate temperature compensation
2132	Direct Zone/Zone 1 ambient temperature nominal value When an OpenTherm (OT) ambient thermostat is connected to the thermal unit or to the zone control accessory, this parameter is not displayed
2134	Compensation factor of direct Zone/Zone 1 external temperature

Parameter 2125 (installer level)

Between seasons, in certain days, the day external temperature may exceed the limit threshold set in parameter 2125 (summer/winter switching), in this case the heat request in heating mode is interrupted even if the ambient temperature has not yet reached the target setpoint. It is possible to increase the value of Par. 2125 preventing the request from being stopped in heating mode.

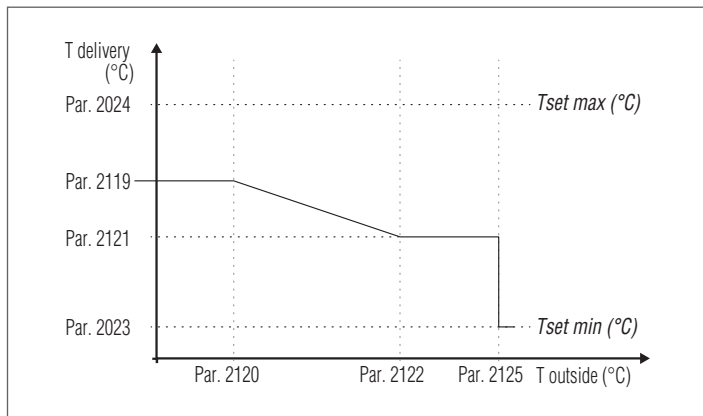

Parameter 2131 (installer level)

In-between seasons when the external temperature gets closer to the maximum limit set in Par. 2122, the delivery temperature calculated in climatic curve could be different from the one suitable to meet the request. This parameter performs a non-linear correction of the climatic curve to offset this difference.

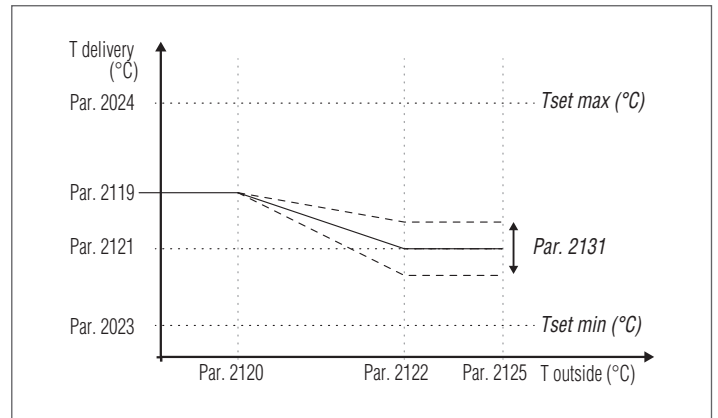

Parameter 2132 (installer level)

Main Zone/Zone 1 ambient temperature nominal value. This parameter defines the required ambient temperature with which the regulator calculates the heating delivery setpoint. A higher or lower required ambient temperature moves the heating curve upwards or downwards on a 45° axis. If, in heating mode 1 (Par. 2001 = 1) an OpenTherm (OT) ambient thermostat is connected to the thermal unit or to the zone control accessory, this parameter is not used since the OT ambient thermostat directly provides the regulator with the ambient temperature setpoint.

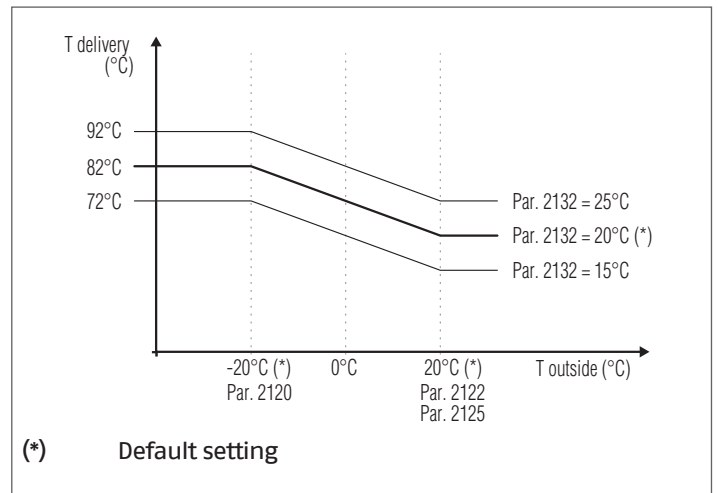

Parameter 2130 (user level)

The parallel shift of the climatic curve is used to modify, in a uniform way, the delivery temperature for the whole scale of the external temperature. Changing the value of this parameter will correct the climatic curve if the ambient temperature is too high (set a negative value) or too low (set a positive value). If there is an Open Therm thermostat, this value is not considered. This parameter allows the user to directly and easily increase (positive value) or decrease (negative value) the delivery temperature to the heating system and thus the ambient temperature.

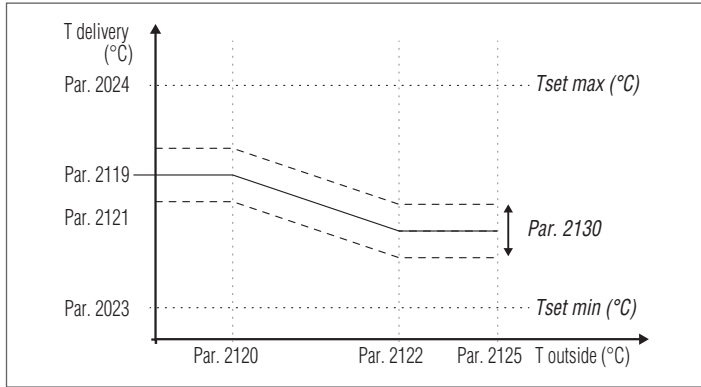

Parameter 2134 (installer level)

Each building has its own thermal characteristics, therefore the time needed to set up the heating system can differ even among buildings located in the same area, with the same external temperature.

By using this parameter it is possible to modify the heating system reactivity adapting its response to the thermal characteristics of the building and thus optimising the environmental comfort.

Modifying the setting of this parameter (0-100%) increases or decreases the speed at which the delivery temperature changes according to the external temperature change.

Setting a higher value will improve the building insulation.

Example:

- 0%: The delivery temperature changes quickly when the external temperature changes.
- 100%: The delivery temperature changes slowly when the external temperature changes.

The request is enabled upon the closing of the ambient thermostat/heat request contact, provided that the external temperature does not exceed the value defined by parameter 2125. If the external temperature exceeds that set in parameter 2125, the burner stops even in the presence of a heat request.

⚠ If the external probe (accessory) is not detected (not installed or damaged), the system makes a heat request at the maximum setpoint set (Par. 2024).

Mode 2: continuous operation with variable setpoint and external probe (accessory) and ambient thermostat (AT) night reduction

In this mode:

- The external probe (accessory) is necessary to enable the thermal unit operation.
- The OpenTherm (OT) communication is not enabled and any OT thermostat connected is supplied but signals a "communication error".
- Input 0-10V is not used.
- The Modbus communication is not enabled.

The equipment works with a variable setpoint defined by the climatic curve (which can be set as described in mode 1) according to the external temperature. The heat request is active regardless of the closing of the ambient thermostat/heat request contact and stops only when the external temperature is higher than that defined by the parameter 2125.

Par. No.	Description
2023	Minimum heating setpoint
2024	Maximum heating setpoint
2119	Direct Zone/Zone 1 heating setpoint at the minimum external temperature The range of this parameter is limited to the values of Minimum (Par. 2023) and Maximum (Par. 2024) setpoints.
2120	Direct Zone/Zone 1 minimum external temperature It defines the minimum external temperature to which the heating maximum setpoint in Par. 2119 must be associated
2121	Direct Zone/Zone 1 heating setpoint at the maximum external temperature (Par. 2122) It sets the minimum heating setpoint when the external temperature is equal to the value set in parameter 2122 (basic external temperature)
2122	Direct Zone/Zone 1 maximum external temperature It sets the external temperature at which the boiler setpoint must be reduced, according to the value defined in parameter 2121
2125	Direct Zone/Zone 1 summer/winter switching It stops the request in heating mode when the external temperature is higher than this setpoint
2130	Parallel shift of direct Zone/Zone 1 climatic curve
2131	Direct Zone/Zone 1 mild climate temperature compensation
2132	Direct Zone/Zone 1 ambient temperature nominal value When an OpenTherm (OT) ambient thermostat is connected to the thermal unit or to the zone control accessory, this parameter is not displayed
2134	Compensation factor of direct Zone/Zone 1 external temperature

The parameter 2133 defines by how many degrees the setpoint decreases (night reduction) when the ambient thermostat/heat request contact opens.

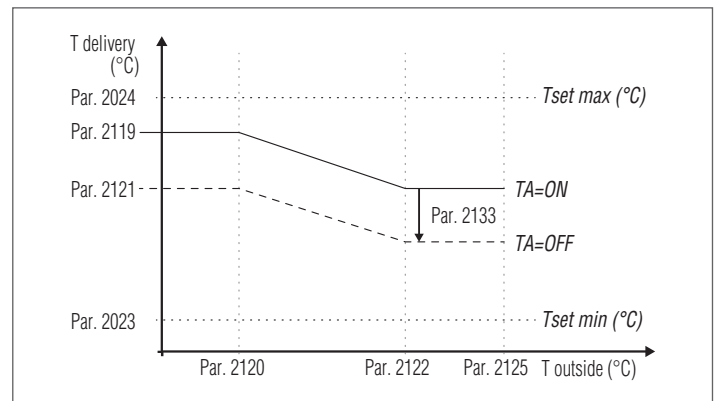

⚠ If the external probe (accessory) is not detected (not installed or damaged), the system makes a heat request at the maximum setpoint set on the climatic curve.

Mode 3: continuous operation with fixed setpoint and night reduction with ambient thermostat (AT)

In this mode:

- External probe is not required.
- The OpenTherm (OT) communication is not enabled and any OT thermostat connected is supplied but signals a "communication error".
- Input 0-10V is not used.
- The Modbus communication is not enabled.

The fixed setpoint adjustment procedure is the same of mode 0. The only difference is that the request is always active and the setpoint is decreased (night reduction) by the value defined by the parameter 2133 upon the opening of the ambient thermostat/heat request contact.

Par. No.	Description
2023	Minimum heating setpoint
2024	Maximum heating setpoint
2103	Direct Zone/Zone 1 setpoint in heating mode Par. 2001= 0 and 3 The thermal unit adjustment determines the boiler setpoint in heating mode, using the highest value among the requests of all the active zones (Par. 1101, 1201, 1301) If Zone 1 is configured as mixed, the value set in parameter 1112 will be used as setpoint
2133	Direct Zone/Zone 1 setpoint night reduction in heating mode Par. 2001= 2 or 3 It defines by how many degrees the heating setpoint will be reduced at the opening of the ambient thermostat (AT) contact The reduction of the delivery temperature affects all the active heating zones and it can be used when the AT terminal of every zone regulator is jumpered.

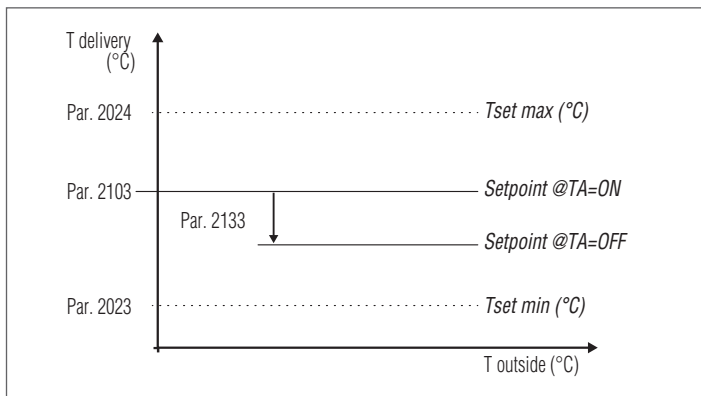

Mode 4: operation with variable setpoint according to the value of the input signal 0-10V

In this mode:

- External probe is not required.
- The OpenTherm (OT) communication is not enabled and any OT thermostat connected is supplied but signals a "communication error".
- The Modbus communication is not enabled. If a device is connected to the Modbus, the values on the remote device are not updated.

The parameters regulating such temperature are:

Par. No.	Description
2023	Minimum heating setpoint
2024	Maximum heating setpoint
2025	Minimum input voltage 0-10V in heating mode Par. 2001 = 4
2026	Maximum input voltage 0-10V in heating mode Par. 2001 = 4

The operation set-point is adjusted on the basis of the following curve:

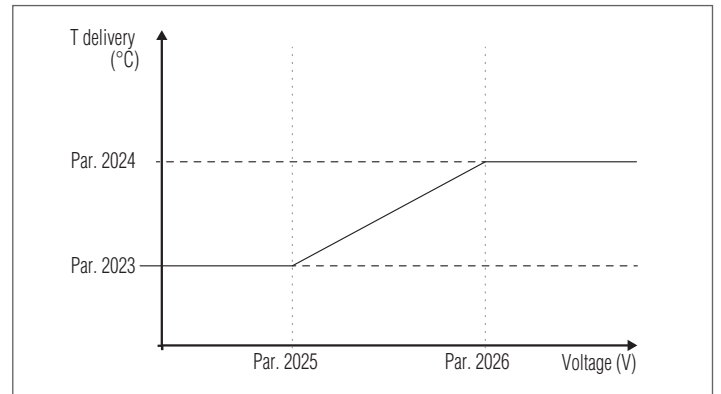

3.2.6 Setting the domestic hot water parameters

The thermoregulation on the thermal unit allows having many configurations for the management of the domestic hot water production.

Domestic hot water request setting

When the temperature detected by the heater probe drops below the DHW setpoint value (Par. 2047) minus the hysteresis value (Par. 2036) the regulator detects a domestic hot water request and activates the circulator switching the 3-way diverting valve on domestic circuit.

In this case, the circulator works with a setpoint (Par. 2049).

The burner turns on when the temperature detected by the delivery probe drops below the DHW setpoint value (Par. 2047) plus the value defined in parameter 2038 minus 3°C (hysteresis), this value corresponds by default to 69°C.

The request is met when the temperature detected by the heater probe exceeds the DHW setpoint value (Par. 2047) plus the hysteresis value (Par. 2037).

The circulator carries on working for the post-circulation time (Par. 2044).

The burner turns off when the temperature detected by the delivery probe exceeds the DHW setpoint value (Par. 2047) plus the value defined in parameter 2038 plus 3°C (hysteresis), this value corresponds by default to 75°C.

3.2.7 Heat request priority

Priority setting

The parameter 2042 defines the priority between domestic and heating circuit.

Four modes are envisaged:

- 0: Time priority between the two circuits. In case of simultaneous request, the first priority is assigned to the domestic circuit for a time period defined in parameter 2043. Once this time period has elapsed, the priority is assigned to the heating circuit (for the same time period) and so on, alternately, until the request of one or both circuits stops;
- 1: Priority assigned to the heating circuit;
- 2: Priority assigned to the domestic circuit (factory setting).
- 3: Parallel. Both circuits operate simultaneously, with the proviso that the delivery temperature requested by the DHW circuit must be lower than or equal to the setpoint requested by the heating circuit. When the temperature requested by the DHW circuit is higher than the heating setpoint, the heating circuit pump is turned off and priority is switched to the DHW circuit.

3.2.8 Special functions

When a special function is active, a specific message is shown on the display of the device control interface.

Pump activation protection during a Domestic Water request

If during a domestic water request the delivery temperature of the burner is lower than that of the heater the pump will not be activated.

Frost protection

The anti-freeze protection function protects the system against freezing.

When the anti-freeze function is active, the message "AFro" is displayed.

The intervention modes are the following:

- **Boiler anti-freeze protection (Par. 2074):** If the temperature of the delivery probe of the device drops below 5°C the burner turns on and stays on until the delivery temperature exceeds 10°C (with the external probe connected the protection activates only with external temperature values < 10°C).
- **Heating circuit anti-freeze protection (Par. 2075):** If the burner stays off for 6 consecutive hours the circulator and the 3-way diverting valve of the device will activate for 5 minutes. If the temperature of the delivery probe of the device drops below 5°C the burner turns on and stays on until the delivery temperature exceeds 10°C (with the external probe connected the protection activates only with external temperature values < 10°C).
- **Domestic circuit heater anti-freeze protection (Par. 2076):** If the temperature of the heater probe drops below 5°C the burner turns on and the circulator and 3-way diverting valve will activate. The burner stays on until the temperature of the heater probe exceeds 10°C and the circulator carries on working for the post-circulation time (Par. 2044). With the external probe connected the protection activates only with the external temperature values < 10°C.

Venting (Par. 2090)

The function is automatically enabled at the first start-up and at each reset of the power supply.

When the function is active, the message "Air" is displayed.

During the venting, the circulator is enabled, so that the air which may be present inside the system circuit can exit through the automatic drain valve of the device.

The status of the light guide changes to flashing green.

During venting it is possible to deactivate the function by setting the parameter 2090 = 0

In the event of a low pressure error (40 and 41) or error of the pressure transducer (42), the bleed cycle is interrupted.

Protection against temperatures that are too high

This function prevents a possible safety thermostat triggering.

If the temperature of the boiler goes above 85°C, the burner goes off and the pump continues to operate to get rid of the excess heat (post-circulation).

Circulator and 3-way valve activation every 24 hours

Every 24 hours the circulator and 3-way diverting valve are activated for 30 seconds (only in heating mode 0,1,4).

This function prevents the circulator and valve from getting stuck in a determined position.

Test mode (chimney sweeper)

When this function is enabled (Par. 200 = 1) the equipment works at maximum power and the 3-way diverting valve switches on the domestic circuit for a time (which cannot be changed) of 15 minutes, then it goes back to its normal operation.

It is possible to interrupt at any moment the operation in test mode (Par. 200 = 0). If the delivery probe of the device reaches 82°C (maximum operating temperature) the burner turns off.

When using this function, it is recommended to leave one of the domestic hot water valves open, in order to discharge excessive heat.



Warning! Water at high temperature is circulating in the system.

Anti-legionella function (Par. 2080) - With Heater Probe only

The function is automatically activated by connecting the storage tank sensor, each time the electric power supply is restored, or daily if necessary (set Par. 2080 =2).

When the function is on the message "ALEG" is shown next to the storage tank temperature.

The function increases the water temperature inside the heater up to 60°C and keeps it for 30 minutes.

Once this time has elapsed, the control box normal operation is restored.

3.2.9 Ignition failure

If an ignition or operating anomaly occurs, the thermal unit display will show a text message (small digit) and a number (large digit), which vary according to the anomaly detected.

For a detailed description, see the error list.

There are 3 error levels:

- Permanent (Loc)
- Temporary (Err)
- Alerts (AttE)

The section with the large digit will display the error number and, according to the error / alert, a message which will cyclically blink together with the number.

For a detailed description, see the error list.

Permanent Error

The text "Loc" is displayed together with the permanent error number. The icon  indicates that the burner is disabled. The equipment must be manually reset by keeping the key "ENETER/RESET" pressed.



Temporary Error

The text "Err" is displayed together with the temporary error number.

The icon  indicates that the burner is disabled. The lock-out error must be solved.

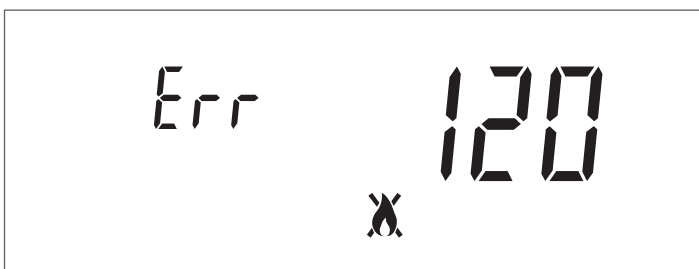

Warnings

The text "AttE" is displayed together with the alert number. The equipment is not locked out, but its functions may be limited (according to the alert).



3.3 Checks during and after initial start-up

Once the boiler has started up, make sure that it shuts down and re-starts properly when:

- By changing the set temperature;
- By moving the main switch from (I) to (0) and vice versa;

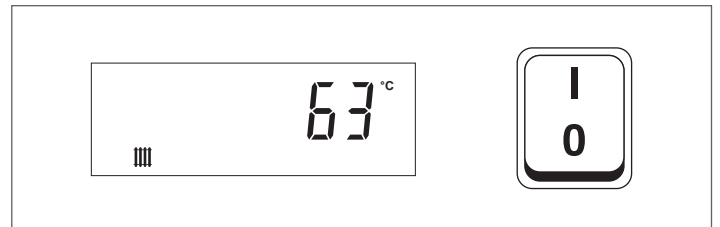

- The room thermostat or timer setting is changed;

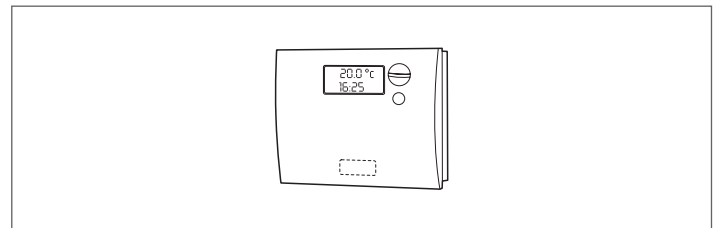

- Check that the pump turns freely as deposits and/or residue may prevent this from happening, especially after long periods of inactivity;

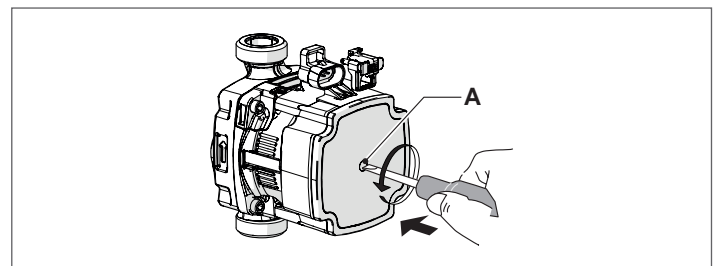

Releasing the pump shaft (if necessary)

- insert a screwdriver in the hole (A) in the pump.
- press and turn the screwdriver to release the driveshaft.

 Take extreme care when doing this so as not to damage the components.

- Check that the thermal unit has come to a complete stop by setting the main switch of the equipment and the main switch of the system to "off".

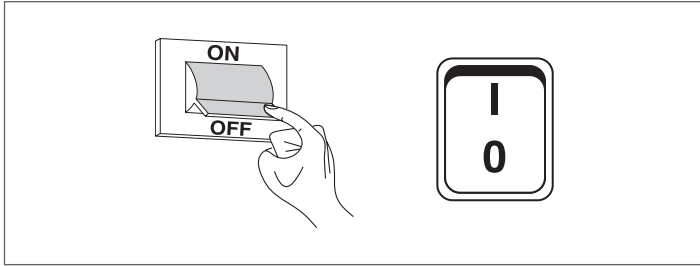

If all the requirements are fulfilled, restart the thermal unit and carry out the analysis of the combustion products by enabling the test mode (Par. 200 = 1).

During the test mode (chimney sweeper), the equipment works at the maximum power for a time period of 15 minutes, then it is automatically disabled.

When using this function, it is recommended to leave one of the domestic hot water valves open, in order to discharge excessive heat.

Once the analysis of the combustion products is complete, disable the function (Par. 200 = 0).

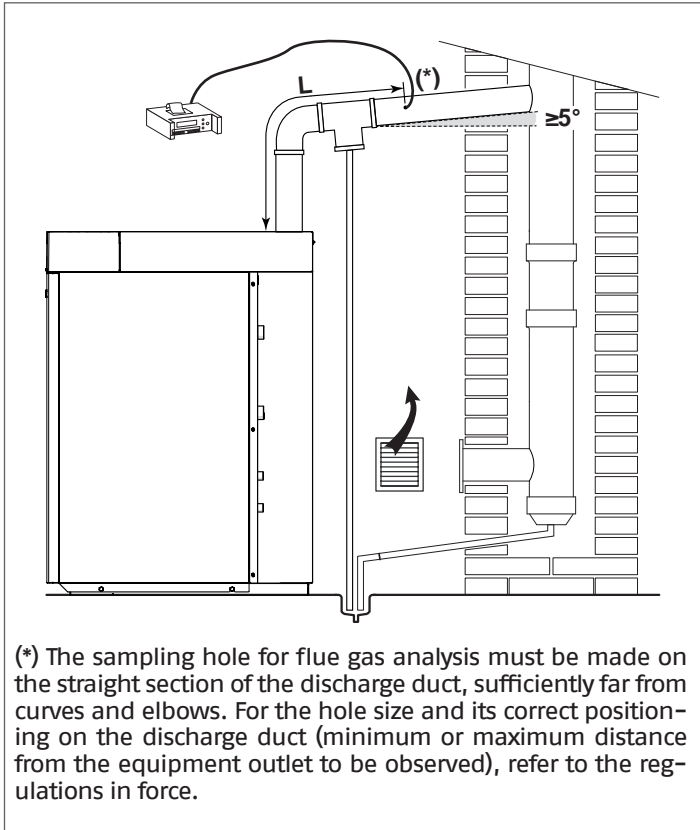

(*) The sampling hole for flue gas analysis must be made on the straight section of the discharge duct, sufficiently far from curves and elbows. For the hole size and its correct positioning on the discharge duct (minimum or maximum distance from the equipment outlet to be observed), refer to the regulations in force.

⚠ Always plug the sampling hole after analysing the flue gases.

3.3.1 Burner control and adjustment

ADJUSTING PUMP PRESSURE

Turn the adjuster screw (1) to achieve the pressure setting specified in the table.

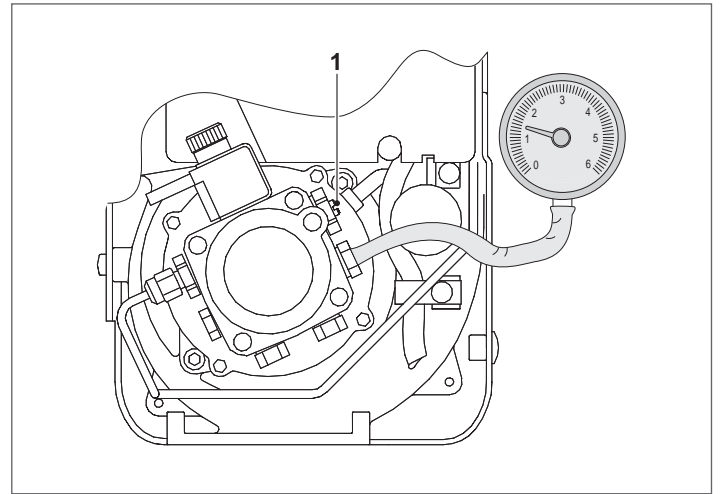

INSIEME EVOe 25 B/70 LN (*)	
Adjusting pump pressure	11,5 bar

(*) Burner with oil heater

ADJUSTING THE AIR DAMPER

The air damper can be adjusted without removing the burner cover.

- Use an Allen key to turn the adjuster screw (1) to achieve the required setting on the graduated scale (2)

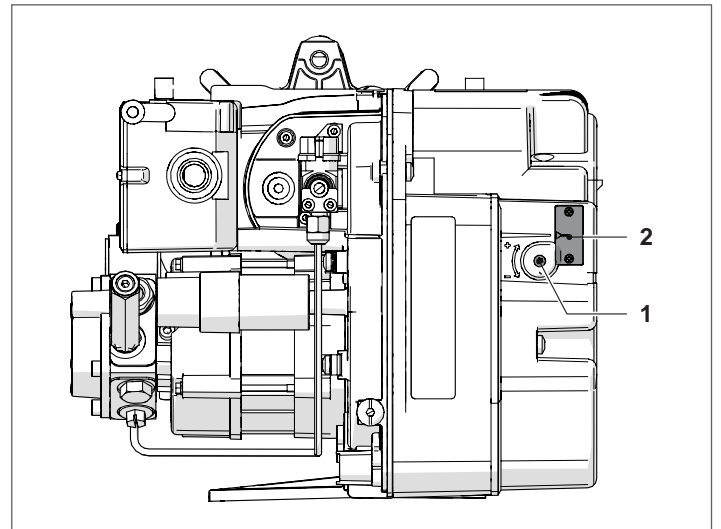

INSIEME EVOe 25 B/70 LN (*)	
Adjusting the air damper	3,6

(*) Burner with oil heater

3.3.2 Burner functioning and programming

Normal functioning

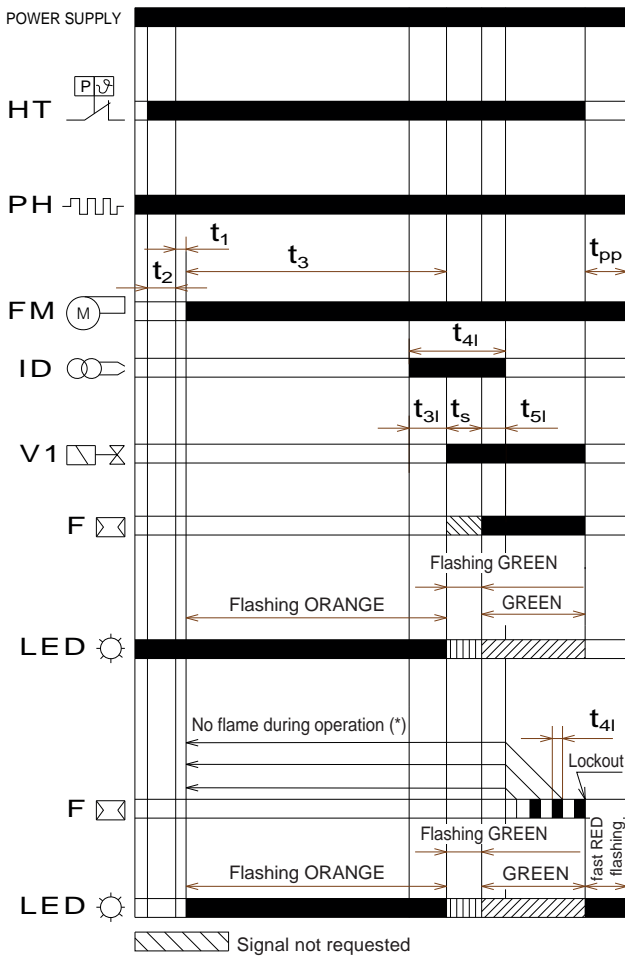

- HT Heat request
- PH Pre-heater
- FM Fan motor
- ID Ignition electrode
- V1 Fuel oil valve
- F Flame detector
- LED Colour of button LED
- t1 Wait time
- t2 Initialisation time for checking
- t3 Pre-purging time
- t3i Pre-ignition time
- t3l Pre-ignition time
- t4i Total ignition time
- t4l Reaction time to achieve safety lockout due to lack of flame
- t5i Post-ignition time
- ts Safety time
- tpp Post-purging time
- (*) Only 3 consecutive ignitions are allowed

	DESCRIPTION	VALUE
t0	Standby: the burner waits for a heat request	-
t1	Standby time for an input signal: reaction time, control box remains in waiting mode for t1	≤ 1 sec
t2	Initialisation verification time: time following startup of main power supply	3,5 sec
t2l	Checks extraneous light or parasite flame during t2: waiting mode for t2l, then lockout: the motor does not start	25 sec
t3	Pre-purging time: the fan motor runs then the fuel oil valve opens	15 sec
t3l	Checks extraneous light or parasite flame during pre-purging: control box goes into lockout at the end of t3l	25 sec
t3i	Spark pre-ignition time	2 sec
ts	Safety time	5 sec
t4i	Total spark ignition time	10 sec
t4l	Valve deactivation reaction time following flame failure	≤ 1 sec
t5i	Spark post-ignition time	3 sec
-	Minimum time to reset the control box using reset button	0,4 sec
tr	Cycle repetition: max. 3 repeats of the complete ignition sequence if flame fails during normal functioning; the controller enters lockout if no flame is detected after the last ignition attempt	3 repeats
tpp	Post-purging time: additional purging time at the end of the heat request. It can be interrupted by a new heat request	60 sec

Lockout caused by ignition failure

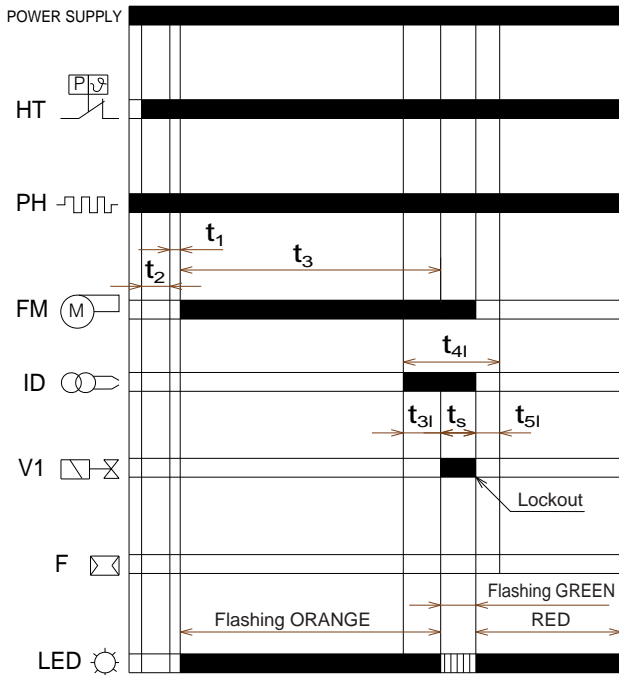

Lockout caused by extraneous light during pre-purging

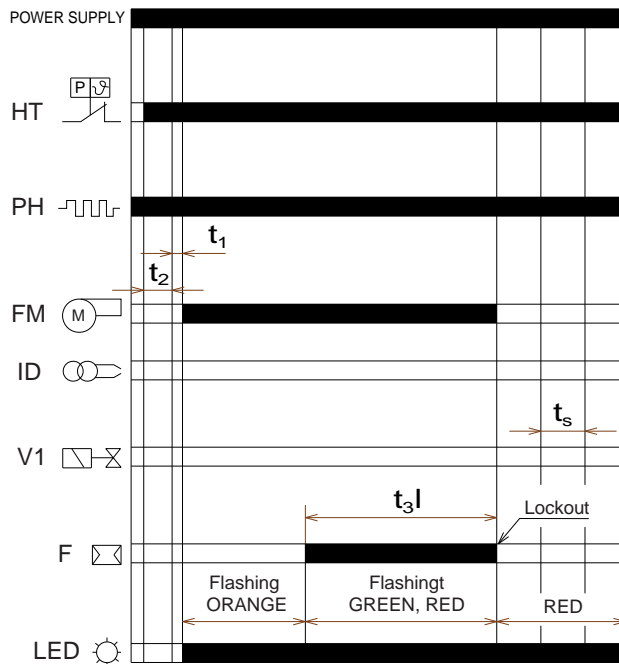

	DESCRIPTION	VALUE
t0	Standby: the burner waits for a heat request	-
t1	Standby time for an input signal: reaction time, control box remains in waiting mode for t1	≤ 1 sec
t2	Initialisation verification time: time following startup of main power supply	3,5 sec
t2l	Checks extraneous light or parasite flame during t2: waiting mode for t2l, then lockout: the motor does not start	25 sec
t3	Pre-purging time: the fan motor runs then the fuel oil valve opens	15 sec
t3l	Checks extraneous light or parasite flame during pre-purging: control box goes into lockout at the end of t3l	25 sec
t3i	Spark pre-ignition time	2 sec
ts	Safety time	5 sec
t4i	Total spark ignition time	10 sec
t4l	Valve deactivation reaction time following flame failure	≤ 1 sec
t5i	Spark post-ignition time	3 sec
-	Minimum time to reset the control box using reset button	0,4 sec
tr	Cycle repetition: max. 3 repeats of the complete ignition sequence if flame fails during normal functioning; the controller enters lockout if no flame is detected after the last ignition attempt	3 repeats
tpp	Post-purging time: additional purging time at the end of the heat request. It can be interrupted by a new heat request	60 sec

- HT** Heat request
- PH** Pre-heater
- FM** Fan motor
- ID** Ignition electrode
- V1** Fuel oil valve
- F** Flame detector
- LED** Colour of button LED
- t1** Wait time
- t2** Initialisation time for checking
- t3** Pre-purging time
- t3i** Pre-ignition time
- t3l** Pre-ignition time
- t4i** Total ignition time
- t4l** Reaction time to achieve safety lockout due to lack of flame
- t5i** Post-ignition time
- ts** Safety time
- tpp** Post-purging time

Functioning status display

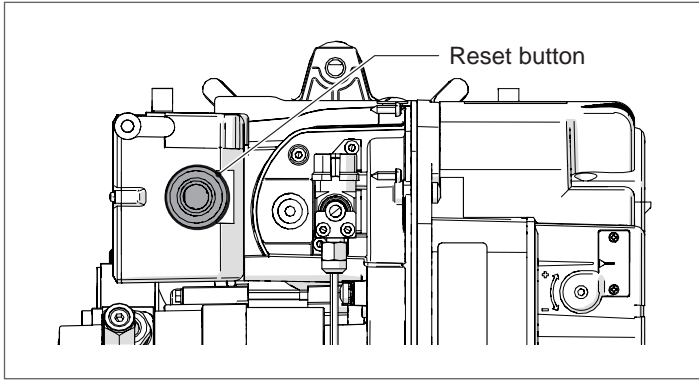

Functioning status	Reset button LED colour	Flash time	Seconds	
			ON	OFF
OFF	○ OFF	-	-	-
Pre-ventilation	● Flashing ORANGE	Slow	0,5	0,5
Safety time	● Flashing GREEN	Slow	0,5	0,5
Normal functioning position	● GREEN	-	Steady ON	
Extraneous light or false flame signal	●● GREEN, RED alternate flashing	Slow	0,5	0,5
Power supply frequency error	○ ORANGE	-	Steady ON	
Internal voltage error	●● ORANGE, GREEN alternate flashing	Fast	0,2	0,2
Reset button anomaly	●● GREEN, RED alternate flashing	Fast	0,2	0,2
Lockout for flame failure after Ts	● RED	-	Steady ON	
Lockout for extraneous light or false flame signal	● RED flashing	Slow	0,5	0,5
Lockout for maximum number of cycle repetitions (flame failure during functioning)	● RED flashing	Fast	0,2	0,2
Lockout for fan motor fault	●● RED, ORANGE flashing	Reversed	2,5	0,5
Lockout for fuel oil valve fault	●● RED, GREEN flashing	Reversed	2,5	0,5
Lockout for EEPROM fault	●● ORANGE, GREEN alternate flashing	Slow	0,5	0,5

Fault diagnosis - lockouts

Description of lockout	Lockout time
Presence of extraneous light during standby	After 25 seconds
Pre-heating not finished	After 600 seconds
Presence of extraneous light during pre-purging	After 25 seconds
Detection of extraneous light during post-purging	After 25 seconds
Flame not detected by end of safety time	5 seconds after the activation of the fuel oil valve
Flame failure during functioning	After 3 ignition attempts
Fan motor fault	Immediate (during pre-purging)
Fuel oil valve fault	Immediate (during pre-purging)
EEPROM fault	Immediate (during pre-purging)

- ⚠** To reset the control box after visual diagnostics have been displayed, you must press the reset button.
- ⚠** In the event the burner stops, in order to prevent any damage to the installation, do not unblock the burner more than twice in a row. If the burner locks out for a third time, contact the Technical Assistance Service.
- ⚠** In the event there are further lockouts or faults with the burner, the maintenance interventions must only be carried out by qualified, authorised personnel, in accordance with the contents of this manual and in compliance with the standards and regulations of current laws.

MAIN BURNER FUNCTIONS

Heating function always on

The burner is equipped with heating function always on. In case of a heat request, it starts immediately with the start-up sequence.

Shutdown test

If the reset button is pressed during operations for more than 5 seconds and less than 10 seconds, (to avoid going to the next menu) the burner switches off, the fuel valve closes, the flame goes out and the start-up sequence restarts.

If the switch off test is enabled, the number of repetitions of the start-up sequence (see "Recycle and limit of repetitions") and the number of possible resets, are reset.

CONTROLLED SHUTDOWN AND RESTART

After 24 hours of continuous functioning, the controller initiates a controlled shutdown followed by a re-start to ensure that the flame detector is not faulty.

You can reduce reduced shutdown and restart time to 1 hour (see "Programming Mode").

POST-PURGING

The post-purging function keeps the fan running for a set time after the burner shuts down provided there is no new heat request.

When the contacts of the heat request thermostat open, the burner controller shuts down the flame and shuts off the oil supply.

Post-purging does not occur:

- after a lockout;
- if a heat request is cancelled during pre-purging.

Post-purging occurs:

- if a heat request is cancelled during safety time;
- if a heat request is cancelled during normal functioning.

NOTE

If extraneous light or a false flame signal is detected during post-purging, the burner locks out after 25 seconds.

If a new heat request is detected during post-purging, post-purging time is reset, the fan motor stops and a new burner ignition cycle is initiated.

PROGRAMMING MENU

General

The programming menu can be accessed via the integrated reset button during OPERATION and in STAND-BY.

If in the menu page the reset button is not pressed within 10 seconds, the page will be automatically quitted and a green led will start flashing for the time set.

If the number of presses on the reset button exceeds the maximum allowable, the value that stays in memory will be the maximum one.

If the reset button is pressed for more than 60 seconds, a button error will be displayed and the control box will restart.

Menu access block diagram

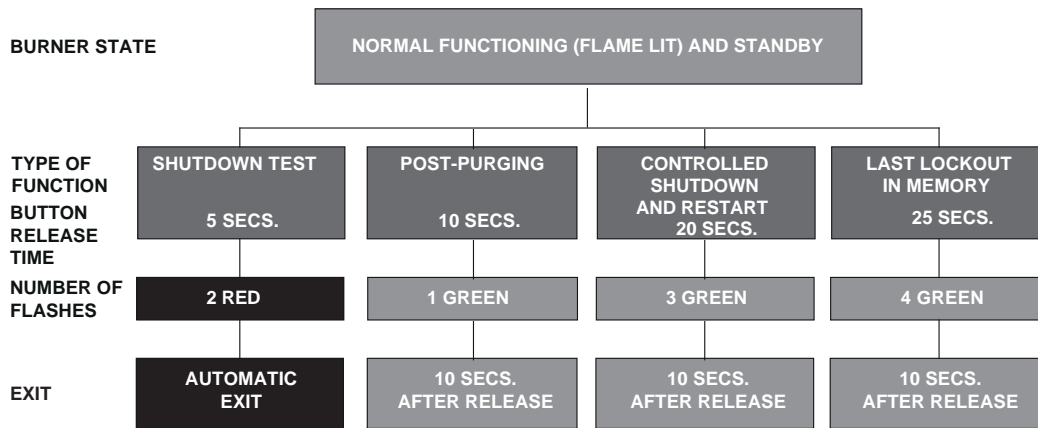

Function	Button release time	No. of LED flashes for menu page	No. of times reset button is pressed	No. of (green) LED flashes	Exit menu
Shutdown test	5s ≤ t < 10s	2 blinks RED	/none	/none	Automatic when flashing finishes
Post-purging	10s ≤ t < 15s	1 flash GREEN	1 = 10 secs. 2 = 20 secs. 3 = 30 secs. 4 = 60 secs. (default) 5 = 120 secs. 6 = 0 secs. (disabled)	1 flash 2 flashes 3 flashes 4 flashes 5 flashes 6 flashes	10 seconds after button is released
Controlled shut-down and restart	20s ≤ t < 25s	3 blinks GREEN	1 = 0 disabled 2 = 1 hour 3 = 24 hours (default)	1 flash 2 flashes 3 flashes	10 seconds after button is released
Last lockout in memory	25s ≤ t < 30s	4 blinks GREEN	/none	Display of lockout type acc. to table	10 seconds after button is released

SHUTDOWN TEST

Shutdown test sequence:

- Programming allowed in OPERATING mode and in STANDBY.
- Press button for 5 sec. ≤ t < 10 sec.
- RED led Blinking 2 times (0.2s. ON; 0.2s. OFF).
- Release the button.
- The burner shuts down and restarts.

The burner shuts down then restarts automatically. Each shutdown test resets (zeroes) the ignition cycle count. No LEDs flash when you exit the shutdown test menu.

POST-PURGING

Post-purging time can be set to a maximum of **120 seconds**. To set post-purging time, proceed as follows.

Post-purging programming sequence:

- programming permitted in NORMAL FUNCTIONING and STANDBY mode;
- Press and hold the burner reset button for between 10 and 15 seconds;
- The GREEN LED flashes 1 once;

- Release the button;
- The GREEN LED stays OFF;
- Press the button from 1 to 5 times (*);
- The GREEN LED flashes ON-OFF at each press and release;
- After 10 seconds, the GREEN LED flashes for the programmed number of times (0.5s ON; 0.5s OFF).

Post-purging de-activation sequence:

- resetting permitted in NORMAL FUNCTIONING and STANDBY mode;
- Press and hold the burner reset button for between 10 and 15 seconds;
- The GREEN LED flashes 1 once;
- Release the button;
- The GREEN LED stays OFF;
- Press the button 6 times (*);
- The GREEN LED flashes ON-OFF at each press and release;
- After 10 seconds, the green LED flashes 6 times (0.5s ON; 0.5s OFF).

If a heat request occurs during the programming of the post-purging function, the controller exits the menu without saving the new setting.

If a heat request occurs while the LED is flashing, the controller exits the menu but the new setting is saved.

CONTROLLED SHUTDOWN AND RESTARTEnabling/disabling sequence:

- programming permitted in NORMAL FUNCTIONING and STANDBY mode;
- Press and hold the burner reset button for between 20 and 25 seconds;
- The GREEN LED flashes 3 times;
- Release the button;
- The GREEN LED stays OFF;
- Press the burner reset button once to enable the function. (*);
- Press the burner reset button twice to select one shutdown every hour. (*);
- Press the burner reset button 3 times to select one shutdown every 24 hours. (*);
- The GREEN LED flashes ON-OFF at each press and release;
- After 10 seconds, the GREEN LED flashes for the programmed number of times (0.5s ON; 0.5s OFF).

Changes to the setting of the controlled shutdown and restart function become active:

- after the next heat request from the thermostat (HT);
- after the next controlled shutdown and restart;
- after a flame failure during normal functioning;
- after power has been switched off and back on again.

DISPLAYING THE LAST LOCKOUT

The burner controller lets you display the last lockout stored in memory. To do so, access the "Programming menu".

This page can be accessed during NORMAL FUNCTIONING or STANDBY mode.

Sequence for displaying the last lockout in memory:

- Press and hold the burner reset button for between 25 and 30 seconds;
- The GREEN LED flashes 4 times;
- Release the button;
- The type of lockout is displayed for 10 seconds.

Lockout type display time can be extended (for another 10 seconds) by pressing the reset button again while the lockout type is being displayed.

- (*) Always wait 1 second between every press and release of the button to ensure correct interpretation of the command.

SHUTDOWN TEST

If the reset button is pressed and held down for a time between 5 and 10 seconds during normal functioning, the burner shuts down, the fuel oil valve closes, the flame goes out and then the startup sequence starts. (Holding the button for longer moves on to the next menu function).

If controlled shutdown and restart is enabled, the number of startup sequence repetitions and the number of resets permitted are both zeroed.

CYCLING AND THE SEQUENCE REPETITION LIMIT

The burner controller has a cycling function. This means that the controller will repeat the complete startup sequence up to 3 times if the flame goes out during normal functioning.

If the flame goes out a fourth time, the burner controller locks out. If the burner controller receives a new heat request while it is repeating the ignition cycle, the ignition attempt count is reset when the heat request thermostat trips.

NOTE

After 510 seconds of continuous operation, a further attempt is made, if necessary.

Disconnect and reconnect power to the burner to obtain a further complete series of startup attempts (max. 3) for the next heat request.

EXTRANEOUS LIGHT OR FALSE FLAME SIGNAL

The presence of the parasite flame or the extraneous light can be detected in the standby condition when the burner is stopped and waiting for a heat request. If the presence of a flame or extraneous light is detected also in the "t2" stage, the motor does not start until the flame signal has disappeared or until lockout has been reached. If extraneous light or a false flame signal is detected when the fan motor is running during pre-purging, the burner stays in purge mode until the light or flame signal stops. If this does not occur within 25 seconds, the burner locks out. If the parasite flame or the extraneous light are detected during the pre-purging, the pre-purging time of 15 seconds is reset and the time for checking for the presence of a parasite flame or extraneous light begins (the motor continues to purge). The function is cumulative and can be carried out a maximum of 2 times. If at the 24th second the parasite flame or the extraneous light disappears, the pre-purging time starts and if the parasite flame or the extraneous light reappear the pre-purging time is reset and the countdown of 25 seconds for checking for the presence of the parasite flame or the extraneous light restarts. The burner also locks out if extraneous light or a false flame signal is detected three times.

If during the recycling due to flame disappearance when operating and the consequent repetition of the start-up sequence the presence of a parasitic flame or extraneous light is detected, the control countdown of 25 seconds starts (for the presence of the parasitic flame or extraneous light). The fault is indicated by the blinking LED (see paragraph "Fault diagnosis - lockouts" on page 55).

PRE AND POST-IGNITION

During pre-ignition, the ignition electrode switches on 2 seconds before the fuel oil valve opens.
During post-ignition, the ignition electrode switches off 3 seconds after the end of safety time.
Ignition remains active throughout safety time.

NOTE

If the ignition cycle repeats continuously or a series of heat requests are received in a short time, the functioning of the ignition transformer is limited to one cycle a minute.

POWER SUPPLY FREQUENCY ERROR

The burner controller automatically detects the frequency of the main power supply over the interval of 50 to 60 Hz. Operating times are verified for both frequencies.

An error is indicated by the LED flashing (see paragraph "Fault diagnosis - lockouts" on page 55).

- If an error is detected before a heat request is made, the burner does not start up and the error is signalled.
- If an error is detected during pre-purging, the burner remains in purge mode and the error is signalled.
- If no error is detected during normal functioning, the burner continues to function normally.
The burner starts up as soon as the error disappears.

FAN MOTOR CONTROL

The burner controller automatically detects the presence of the fan motor and enters lockout in the event of a fan motor failure. An error is indicated by the LED flashing (see the "Fault diagnosis - lockouts" section on page 55).

INTERNAL VOLTAGE ERROR

The burner controller automatically checks that internal voltage is correct. An error is indicated by the LED flashing (see the "Fault diagnosis - lockouts" section on page 55).

- If an error is detected during initialisation, the burner does not start up.
- If an error is detected after a lockout, the burner will not start up.
- If an error is detected after a shutdown test, the burner will not start up.
- If no error is detected during normal functioning, the burner continues to function normally.
The burner starts up as soon as the error disappears.

RESET BUTTON ANOMALY

If the reset button is faulty or is kept pressed for more than 60 seconds, the fault is indicated by the blinking of the LED (see paragraph "Diagnostics of Faults - Lockouts" on page 55) as long as it is present.

This is merely a signal of the error condition.

- If an error is detected during pre-ventilation or safety time, the burner does not enter lockout but continues with the startup sequence.
- If an error is detected during normal functioning, the burner shuts down and does not restart. The error is signalled.
- If an error is detected while the burner is already locked out, no signal is displayed but the burner cannot be reset. The LED stops flashing as soon as the error disappears.

CHECKING THE ELECTRONIC CIRCUIT CONTROLLING THE OIL VALVE

The control box detects the presence of a fault inside the electronic circuit controlling the oil valve, the fault is indicated by the blinking LED (see paragraph "Fault diagnosis - lockouts" on page 55).

- If the anomaly is detected during the initialisation, the burner goes into lockout.
- If the anomaly is detected during the pre-purging, the burner goes into lockout.
- During a recycling, if the fault is detected, the burner does not start and goes into lockout.
- If the fault is not detected during running position the burner remains in operation.

The fault is not detected if the burner is in lockout.

EEPROM CONTROL

The burner controller automatically checks for errors in the microcontroller EEPROM and enters lockout if an error is detected. An error is indicated by the LED flashing (see the "Fault diagnosis - lockouts" section on page 55).

3.4 Error List

When a technical anomaly occurs, the control interface display shows a text message (small digit) and a number (large digit), which indicate the type and level of the detected error.

There are 3 error levels:

- 1 **Permanent:** heating and/or DHW requests are suspended and burner and circulator are switched off. For the error to disappear, keep the key ENTER/RESET on the control interface pressed for 3 seconds or reset the power supply by using the main switch.
- 2 **Temporary:** heating and/or DHW requests are suspended and burner and circulator are switched off. The error disappears automatically when the cause which generated it is solved.
- 3 **Alert:** the thermal unit is not locked out, but its functions may be limited according to the signalled alert code.

The log of the last ten errors occurred can be viewed through the error log (menu 9000 - installer level) (from Par. 9001 to Par. 9010).

3.4.1 Permanent Errors

Message	Error No.	Description
Loc	01	Electronic board hardware fault. Relay deterioration.
Loc	10	Failed ignition/Burner error (see page 68 code of colours to identify the error).
Loc	20	Intervention of safety thermostat or flue limit thermostat
Loc	40	Insufficient pressure in primary circuit. Pressure < 0.5 bar for more than 10 minutes
Loc	42	Pressure transducer not connected or primary circuit pressure too high. Pressure > 2.5 bar for more than 10 minutes

If you see the "Loc 01" error, proceed as follows:

- Check that the phase and neutral power supply are connected correctly
- Replace the electronic board

3.4.2 Temporary Errors

Message	Error No.	Description
Err	41	Primary circuit pressure insufficient (temporary)
Err	60	Domestic hot water probe in short circuit or disconnected.
Err	70	Delivery sensor short circuit or disconnection. Delivery sensor fault/delivery sensor temperature overload
Err	80	Return sensor fault/return sensor temperature overload
Err	99	Too many resets from remote control. NO MORE RESETS
Err	100	Communication lost in zone 1 (temporary)
Err	101	Zone 1 limit thermostat triggering (temporary)
Err	102	Zone 1 delivery probe (temporary)
Err	104	Communication lost in zone 2 (temporary)
Err	105	Zone 2 limit thermostat triggering (temporary)
Err	106	Zone 2 delivery probe (temporary)
Err	108	Communication lost in zone 3 (temporary)
Err	109	Zone 3 limit thermostat triggering (temporary)
Err	110	Zone 3 delivery probe (temporary)

3.4.3 Warnings

Message	Error No.	Description
Atte	44	Primary circuit pressure too high (P>2.5 bar) [TEMPORARY]
Atte	46	Pressure decreasing. Range not critical (0.5 bar < P < 0.8 bar) [TEMPORARY]
Air	--	Deaeration cycle in progress
ALeg	--	Anti-legionella cycle in progress
AFro	--	Anti-freeze cycle in progress

3.5 Temporary or short-term shut-down

In the event of temporary or short-term shut-down (e.g. due to holidays), proceed as follows:

- Remove the power supply by setting the main switch of the equipment and the main switch of the system to "OFF".
- If there is a danger of frost, keep the system on. To reduce fuel consumption, set the heating set point to the minimum allowed value.

3.6 Preparing for extended periods of disuse

If the appliance is not going to be used for a long period of time, the following operations should be carried out: set the main switch of the system to OFF and the main switch of the equipment to (0);

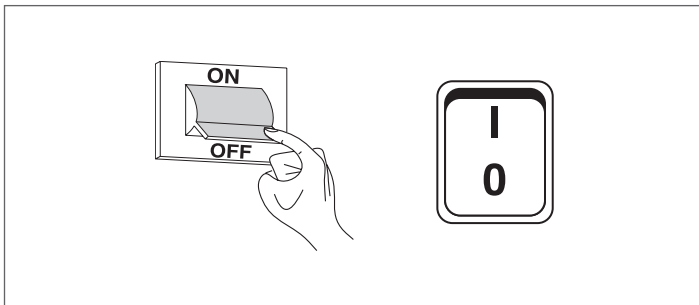

- close the fuel cock and heating circuit water cock.

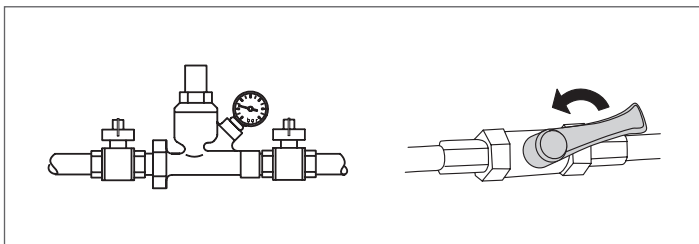

⚠ Drain the central heating circuit if there is any risk of freezing.

3.7 Device cleaning and maintenance

It is essential to clean the boiler and remove carbon deposits from the surfaces of the heat exchanger in order to keep the boiler efficient and economical.

- ⚠** All cleaning operations MUST be performed under the following conditions:
- boiler cold
 - boiler switched OFF
 - Suitable personal protection equipment

Perform the following operations before beginning any maintenance or cleaning:

- set the main switch of the system to OFF and the main switch of the equipment to (0);

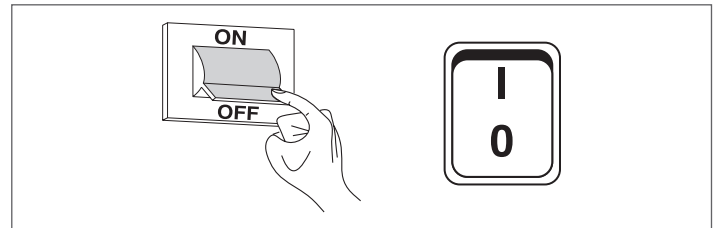

- close all external fuel shut-off cocks.

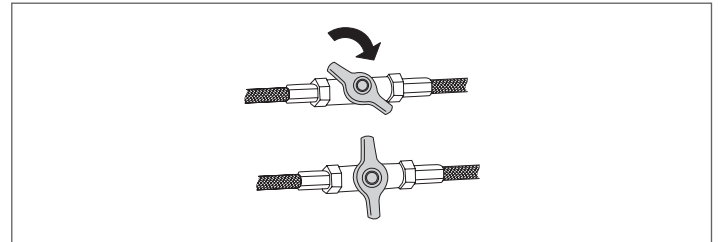

3.8 Annual cleaning

It is mandatory to perform maintenance and cleaning of the device at least once a year.

This operation, carried out by Technical Assistance Service or by professionally qualified personnel, is necessary to monitor and ensure that the flue pipes inside and outside of the device, the fan, the safety valves, the condensate removal devices, the water drainage tubes and all the measurement and control devices are in perfect working order.

3.8.1 Cleaning and maintaining the burner

Proceed as follows to access the internal parts of the boiler:

- remove the fixing screw (2) and extract the front panel (1);

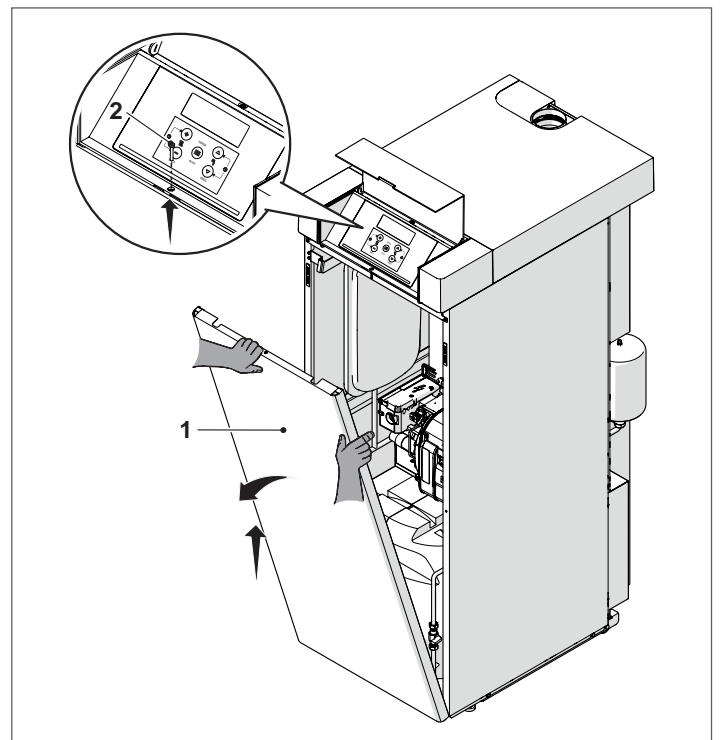

REMOVING THE BURNER

Proceed as follows to remove the burner:

- Close the fuel shut-off cocks;
- disconnect the connector (1);

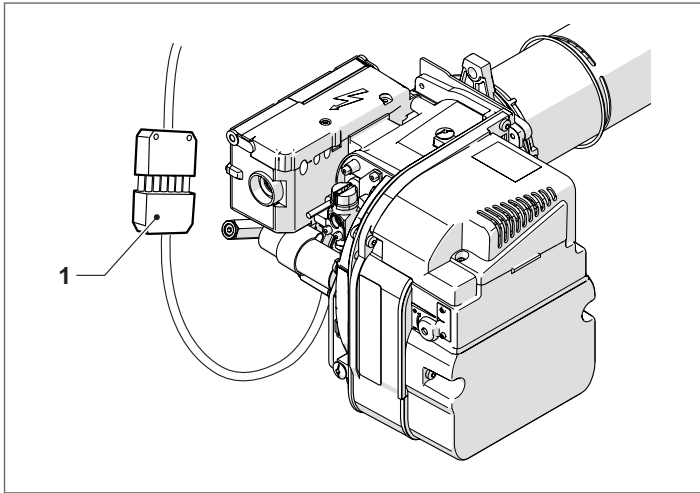

- Unscrew the fixing nut (2) and remove the burner;
- Pull the burner (3) out, taking care not to damage it;

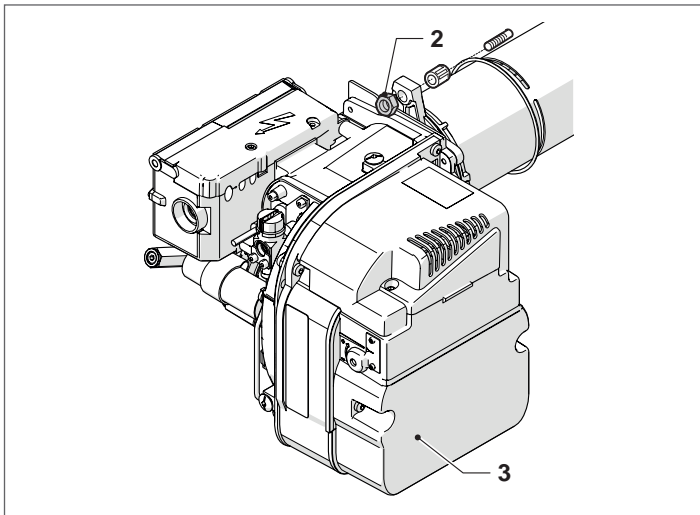

- Place the burner in an upright position.

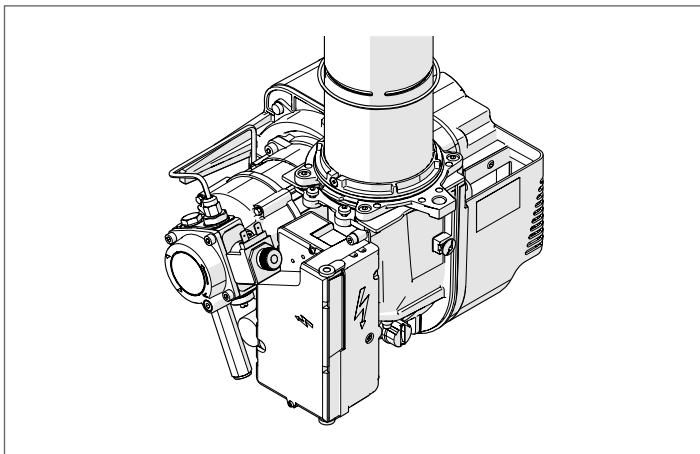

Reverse the above steps to reassemble.

REMOVING THE BLAST TUBE

Proceed as follows to remove the blast tube:

- Remove the screws (1) and remove the blast tube.
- disconnect the high voltage cable (2).

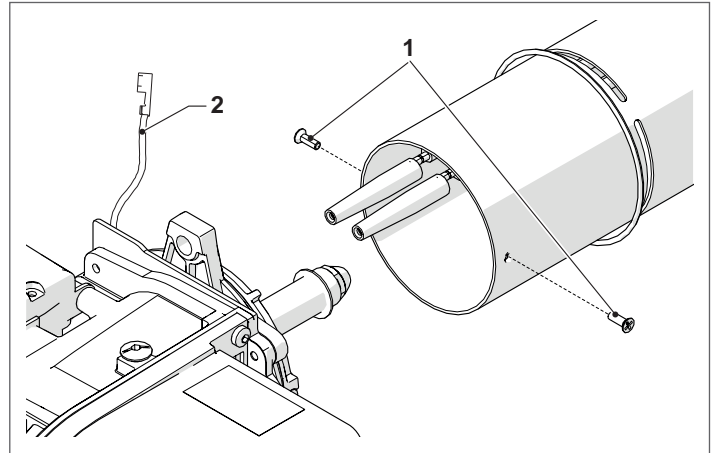

⚠ With the blast tube removed, check its front edge to make sure that it is smooth, free from deposits, burns and dents.

Reverse the above steps to reassemble.

REPLACING THE NOZZLE

	INSIEME EVOe 25 B/70 LN (*)
Nozzle type	0.60 80°HF Fluidics

(*) Burner with oil heater

Remove the blast tube then proceed as follows:

- Clean the electrodes without removing the clamp;
- Hold the nozzle holder (3) steady with one wrench while using a second wrench to remove the nozzle (4)

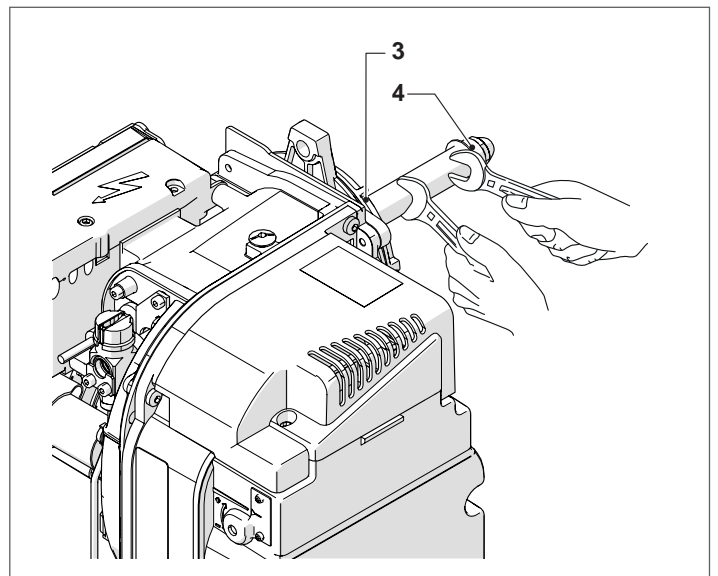

- Make sure that the new nozzle is exactly the same type and size as the old one
- Clean the contact and sealing surfaces
- manually drive and screw the new nozzle fully home, then tighten it properly.

⊖ Do not use nozzles of different make, type and specifications to the original.

ELECTRODE POSITIONING

The positioning of the ignition electrodes (A) is fundamental to obtain reliable flame ignitions. Check their state of wear and correct positioning, as shown in the figure, and replace them if necessary.

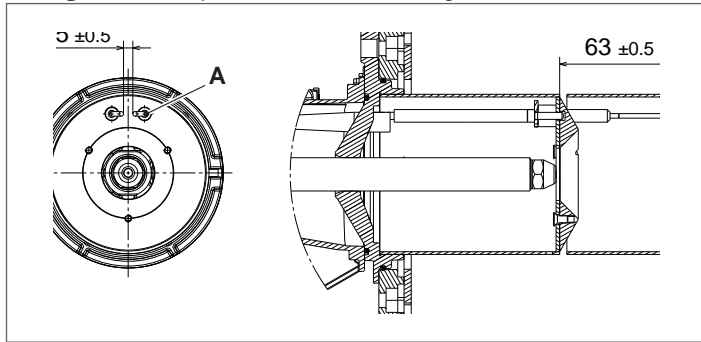

! It is essential to respect the dimensions in the figure.
REMOVING THE ELECTRODES

Proceed as follows to remove the electrodes:

- Loosen the screw (1)
- Extract the electrodes and check them for wear

Reverse the above steps to reassemble.

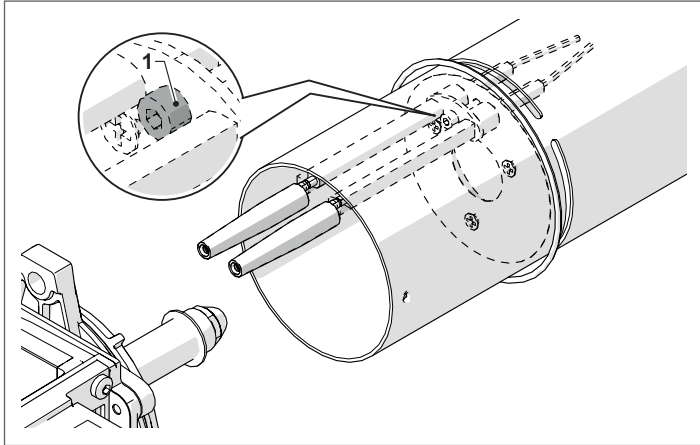

REMOVING THE BURNER CONTROLLER

The burner cover has to be removed first in order to remove the controller.

Proceed as follows:

- Loosen the screw (1), open the cover (2) and remove all the components inside
- Remove the coil (3)
- Unscrew and remove the two screws (4).

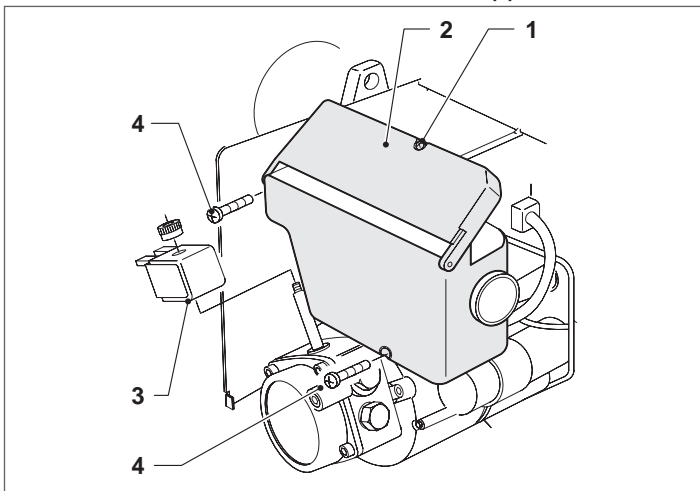

! This operation must be performed with the burner turned off and mains power disconnected.

CLEANING THE FAN

! Clean the inside and the rotor blades of the fan unit to remove any build-up of dust. Accumulated dust reduces the air flow and therefore reduces combustion efficiency, leading to increased emissions.

! Perform maintenance operations paying attention not to damage or unbalance the fan during cleaning operations.

Proceed as follows

- remove the clip (1), take the cable out of the cable tie (2), undo the screw (3) and take out the air shutter unit (4);
- clean the fan and the inside of the air intake opening, using a suitable brush and compressed air;
- if necessary, carefully dismantle the fan, undoing the screw (5).

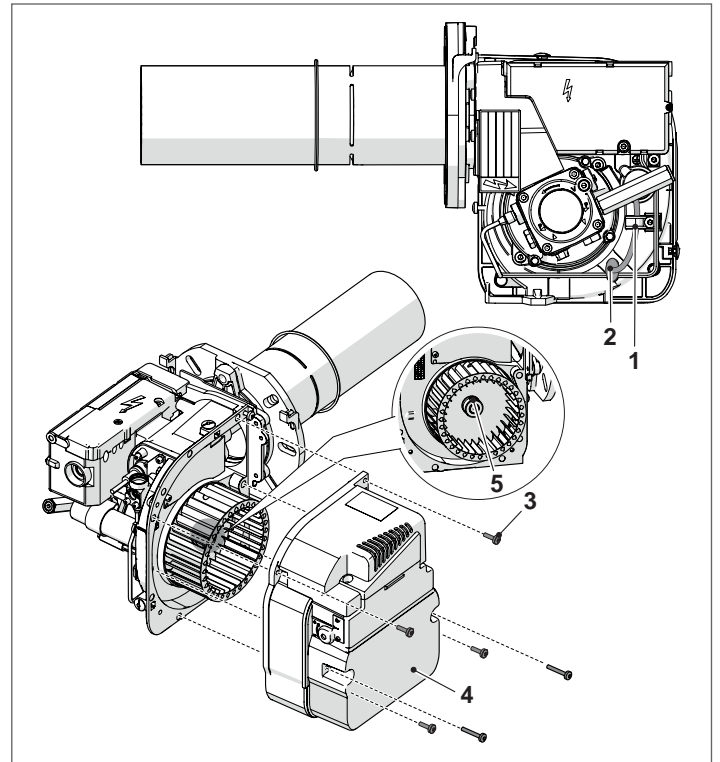

! When reassembling the fan, it is important to put it back in the correct position (B) and tighten the screw (5).

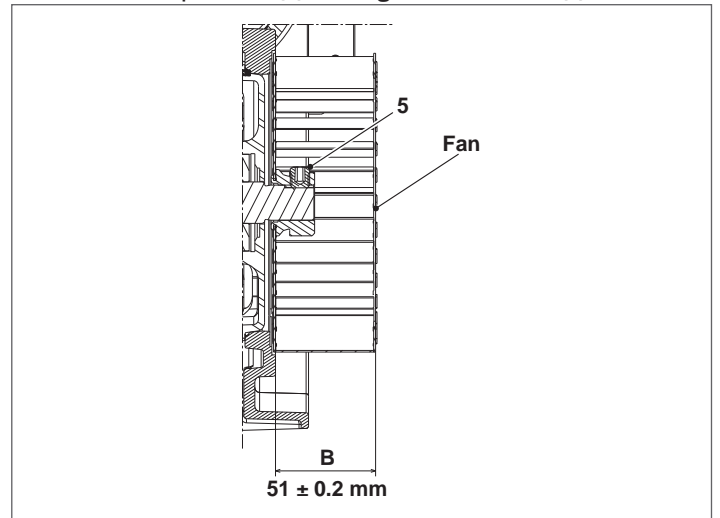

- Reverse the above steps to reassemble. Take care to replace all burner parts in their original positions.

3.8.2 Boiler exchanger cleaning

Proceed as follows to access the internal parts of the boiler:

- remove the fixing screw (2) and extract the front panel (1);

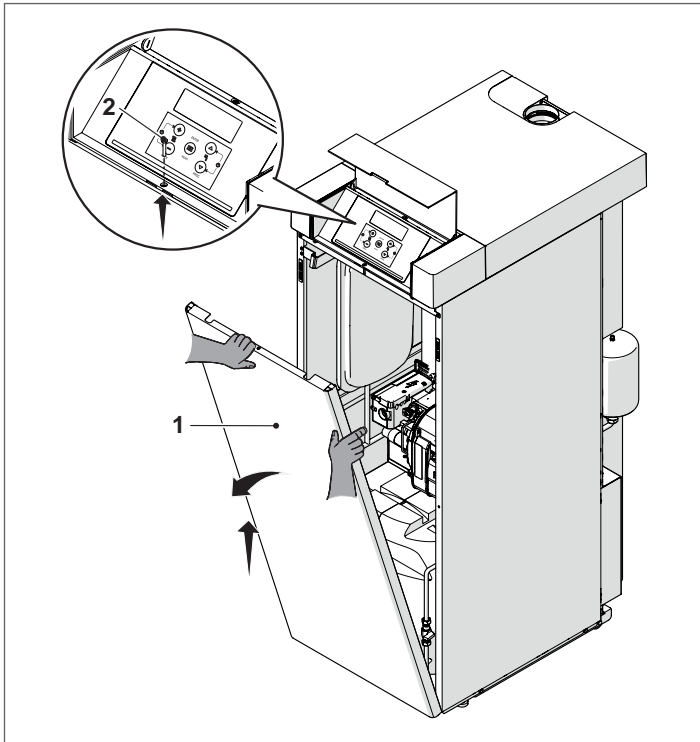

- Remove the burner;
- Remove the top panel (3);
- remove the insulating cover (4);
- remove the screws (5) and slide the flue gas chamber out (6);

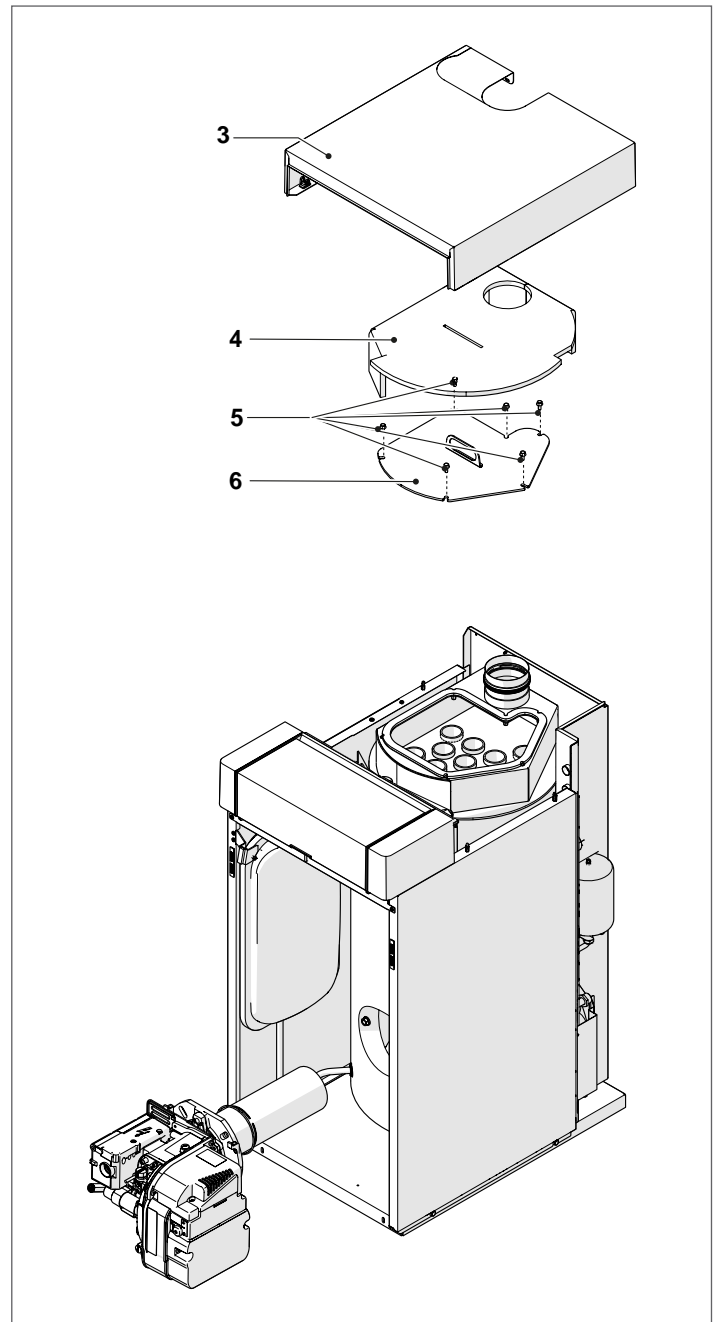

- remove the turbulators (7) and check them for wear and fin angle (replace as necessary);
- use a flue brush (8) or other suitable tool;

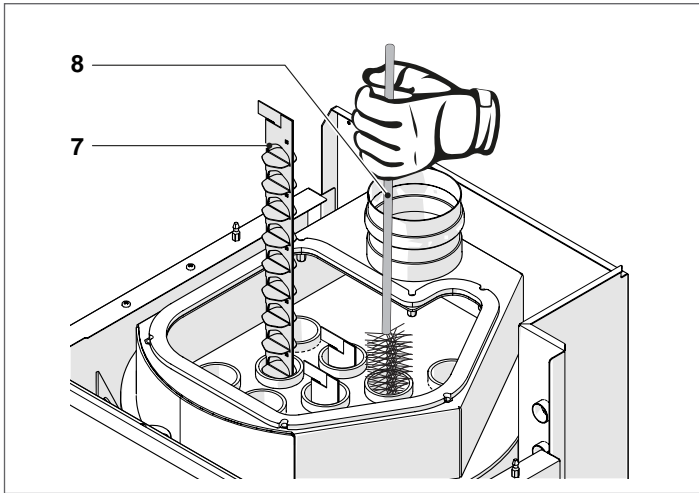

- remove any displaced soot through the combustion chamber hole.

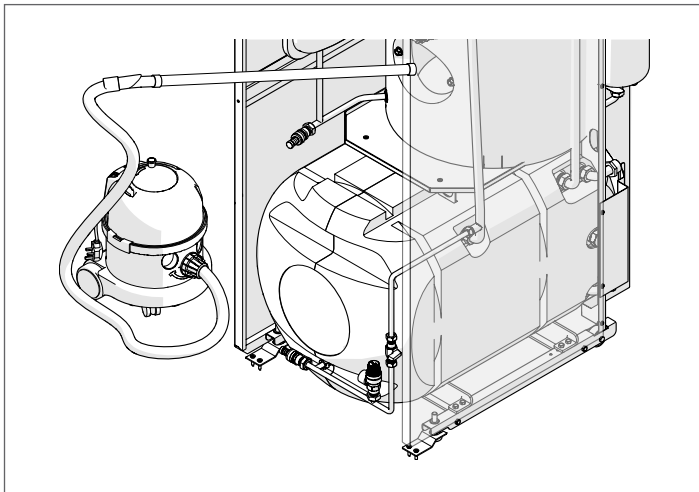

Proceed as follows on completion of cleaning:

- refit the turbulators in the flue gas pipes, making sure that they are correctly seated;
- replace all removed components in the opposite order.

⚠ Before repositioning the flue gas chamber closure, replace the expanded silicone seal.

3.8.3 Checking and replacing the storage cylinder anode

To check the magnesium anode and its wear status:

- remove the front panel (1);
- close the cold water inlet (CWI) shut-off valve;
- Empty the heater through its drain valve, after having connected a rubber hose to the hose connector;
- remove the heater flange insulation;
- remove the magnesium anode (2) using a socket wrench;
- check the wear status and replace it if necessary.

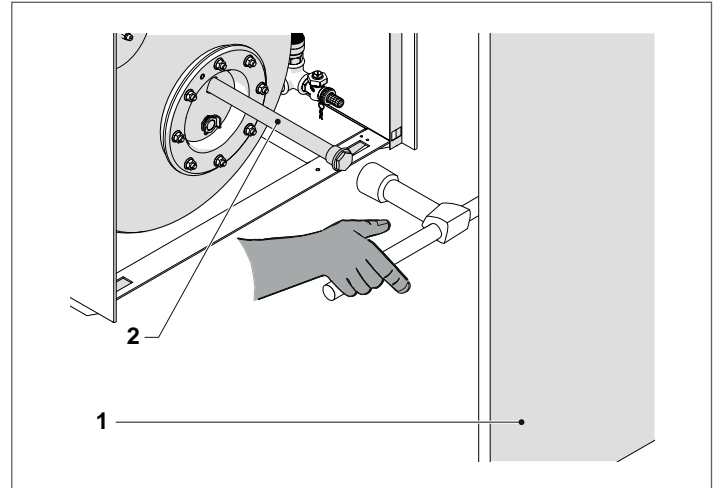

3.9 Extraordinary cleaning

3.9.1 Cleaning the storage cylinder

Ordinary maintenance work must be carried out when needed, in case the heater performance is not satisfying or when the domestic water is particularly hard.

Perform the following operations before beginning any cleaning:

- remove the front panel (1);
- close the cold water inlet (CWI) shut-off valve;
- partially empty the heater through its drain valve, after having connected a rubber hose to the hose connector;
- remove the heater flange insulation;
- extract the heater sensor;
- remove the screws (2) fastening the flange (3) and extract it;

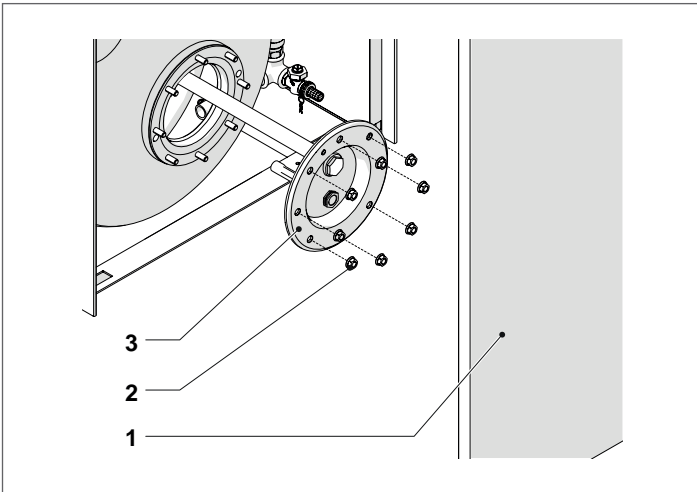

- clean the internal surfaces and remove any residues through the opening;
- check the magnesium anode wear status (4) (replace it if necessary);
- check that the seal (5) is intact.

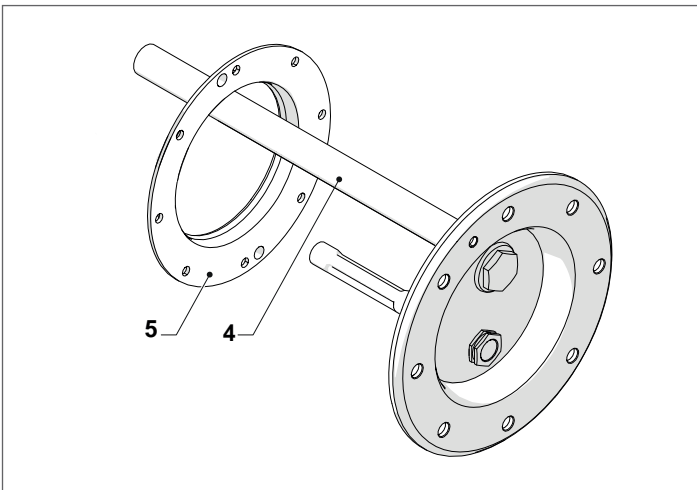

On completion of cleaning, refit all removed parts in the reverse order, taking care to ensure the efficiency of the seals.

⚠ Refit the heater flange with probe holder in the lower side (as shown in the figure) and position the bulb of the heater probe all the way down.

N.B.: Tighten the fixing nuts, proceeding diagonally around the flange to apply pressure uniformly around the seal.

3.10 External cleaning

Clean the boiler's casing panels and control panel with a soft cloth damped in soapy water.

To remove marks from the boiler casing, use a cloth damped in a 50% mix of water and denatured alcohol or a suitable cleaning product.

Wipe the boiler dry after cleaning it.

⊖ Do not use abrasive products, petrol or triethylene.

3.11 Troubleshooting

FAULT	CAUSE	SOLUTION
There is a smell of fumes	Fumes escaping into the air	<ul style="list-style-type: none"> - Check that the burner body is clean - Check that the flue pipes are clean - Check the condition of the boiler seals - Check the quality of combustion
The boiler gets dirty very quickly	Burner badly adjusted	<ul style="list-style-type: none"> - Check adjustment of burner (perform flue gas analysis)
	Blockage in stack	<ul style="list-style-type: none"> - Clean flue pipes
	Burner air intake dirty	<ul style="list-style-type: none"> - Clean the burner air intake
The generator is at temperature but the heating system is cold	Air in the circuit	<ul style="list-style-type: none"> - Bleed the circuit
	Pump malfunctioning	<ul style="list-style-type: none"> - Check/unseize the pump - Change the pump
The boiler does not reach its temperature setpoint	Dirt boiler body	<ul style="list-style-type: none"> - Clean
	Burner capacity insufficient	<ul style="list-style-type: none"> - Check and adjust the burner
	Boiler temperature setpoint	<ul style="list-style-type: none"> - Check correct functioning - Check the temperature setting
The generator triggers a thermal safety block	Safety thermostat / delivery overtemperature	<ul style="list-style-type: none"> - Check correct functioning - Check the temperature setting - Check the electrical wiring - Check the position of the sensor bulbs
	No water	<ul style="list-style-type: none"> - Check the bleed valve - Check the heating circuit pressure
The safety valve keeps opening	Incorrect central heating circuit pressure	<ul style="list-style-type: none"> - Check the circuit pressure - Check pressure reducer functioning - Check efficiency of safety valve
	System expansion reservoir	<ul style="list-style-type: none"> - Check the efficiency of the expansion vessel
The circulator does not work	Pump seized Electrical connections	<ul style="list-style-type: none"> - Check the pump and connections
	The request from the ambient thermostat is missing	<ul style="list-style-type: none"> - Check the temperature controller, sensors and connections

TROUBLESHOOTING

Problem	Diagnostic signal	Probable cause	Remedy
The burner does not ignite when heat is requested	○ OFF	No electrical power	Check voltage at L, N and in power plug Check the condition of the fuses Check that the safety thermostat has not tripped
	●● GREEN, RED alternate flashing	The flame detector reads extraneous light	Eliminate cause of light or false flame signal
	○ OFF	The burner controller connectors are not properly plugged in	Make sure that all connectors are properly connected
	● GREEN flashing	Short circuit connector P not connected	Replace as necessary
The burner goes into lockout before or during pre-purging	● RED flashing slowly	The flame detector is reading extraneous light	Eliminate cause of light or false flame signal
The burner switches off and after a number of attempts to switch back on, goes into lockout	● RED flashing quickly	Lockout for maximum number of cycle repetitions (flame failure during functioning)	Flue gas recirculation above 13%. Check position of outlets and suction
The burner performs pre-purging and ignition correctly but locks out after about 5 seconds	● RED Always ON	Flame detector dirty	Clean the flame detector
		The flame detector is faulty	Change as necessary
		The flame detaches or fails	Check fuel oil pressure and flow rate
			Check the air flow
The burner starts up only after late ignition.	○ OFF	Ignition electrodes incorrectly positioned	Change the nozzle
		Air flow rate too high	Check solenoid valve coil
		Nozzle dirty or worn	Adjust ignition electrodes as instructed in this manual. Adjust air flow rate as instructed in this manual. Replace

4 RECYCLING AND DISPOSAL

The device is primarily composed of:

Material	Component
Metal materials	Pipes, circulator, boiler body
ABS (acrylonitrile-butadiene-styrene)	Control panel enclosure
Glass wool felt	Boiler body insulation
Electrical and electronic components	Cables and wirings, regulator, circulator

At the end of the life cycle, safely remove the components and dispose of them in a responsible manner, in compliance with the installation country's applicable environmental legislation.

⚠ Adequate sorted waste collection, processing and environmentally-friendly disposal contribute to preventing possible negative impacts on the environment and health and promote the reuse and/or recycling of the materials of which the appliance consists.

⚠ Illegal disposal of the product by the owner shall be subject to administrative fines provided for by applicable laws.



A series of horizontal dashed lines spanning the width of the page, providing a template for handwriting practice.



A series of horizontal dashed lines spanning the width of the page, providing a template for handwriting practice.



A series of horizontal dashed lines spanning the width of the page, providing a template for handwriting practice.

RIELLO

RIELLO S.p.A.
Via Ing. Pilade Riello, 7
37045 - Legnago (VR)
www.riello.com

The manufacturer strives to continuously improve all products. Appearance, dimensions, technical specifications, standard equipment and accessories are therefore liable to modification without notice.