

GB **Forced draught gas burners**

Modulating operation

CE

**UK
CA**

EAC

CODE	MODEL	TYPE
20205437	RS 68/EV O2 ULX	S041T2
20205438	RS 120/EV O2 ULX	S042T2
20205439	RS 160/EV O2 ULX	S043T2
20205441	RS 200/EV O2 ULX	S044T2



Translation of the original instructions

1	Information and general warnings.....	3
1.1	Information about the instruction manual	3
1.1.1	Introduction.....	3
1.1.2	General dangers.....	3
1.1.3	Other symbols	3
1.1.4	Delivery of the system and the instruction manual	4
1.2	Guarantee and responsibility.....	4
2	Safety and prevention.....	5
2.1	Introduction.....	5
2.2	Personnel training	5
3	Technical description of the burner	6
3.1	Burner designation	6
3.2	Models available.....	7
3.3	Burner categories	7
3.4	Technical data	7
3.5	Electrical data.....	7
3.6	Maximum dimensions.....	8
3.7	Burner equipment.....	8
3.8	Firing rates	9
3.9	Test boiler.....	11
3.10	Burner description	12
3.11	Electrical panel description.....	13
3.12	Flame control.....	14
3.13	Actuator	16
3.14	PLL52... module (optional)	17
3.14.1	Terminal ratings, cable lengths and cross-sectional areas	17
3.15	Oxygen sensor QGO20 ... (optional).....	18
3.15.1	Technical data QGO20.....	19
4	Installation	20
4.1	Notes on safety for the installation	20
4.2	Handling	20
4.3	Preliminary checks	20
4.4	Operating position	21
4.5	Preparing the boiler	21
4.5.1	Boring the boiler plate	21
4.5.2	Blast tube length.....	21
4.6	Securing the burner to the boiler	22
4.7	Access to head internal part.....	22
4.8	Electrode position.....	23
4.9	Central gas adjustment	23
4.9.1	Central gas setting	23
4.10	Combustion head adjustment.....	24
4.11	Closing the burner	25
4.12	Gas feeding	26
4.12.1	Gas feeding line (Example) - For functional details refer to the gas train manual	26
4.12.2	Gas train.....	26
4.12.3	Gas train installation.....	26
4.12.4	Gas pressure	27
4.13	Electrical wiring	30
4.13.1	Supply cables and external connections passage	31
4.13.2	Motor cable shield	31
4.14	Adjustment fan motor covering with external rpm	32
5	Start-up, calibration and operation of the burner	33
5.1	Notes on safety for the first start-up	33
5.2	Adjustments prior to ignition	33
5.3	Burner start-up	34
5.4	Air / fuel adjustment.....	35

5.4.1	Air adjustment for maximum output	35
5.4.2	Air/fuel adjustment and output modulation system	35
5.4.3	Burner adjustment	35
5.4.4	Output upon ignition	35
5.4.5	Maximum output	35
5.4.6	Minimum output	36
5.5	Final calibration of the pressure switches	36
5.5.1	Air pressure switch	36
5.5.2	Maximum gas pressure switch	37
5.5.3	Minimum gas pressure switch	37
5.5.4	PVP pressure switch kit	37
5.6	Operation	38
5.7	Ignition failure	38
5.8	Burner flame goes out during operation	38
5.9	Stopping of the burner	38
5.10	Final checks (with burner operating)	38
5.11	Description of O2 trim control (optional)	39
5.11.1	Operating principle of O2 trim control	39
6	Maintenance	40
6.1	Notes on safety for the maintenance	40
6.2	Maintenance programme	40
6.2.1	Maintenance frequency	40
6.2.2	Safety test - with gas feeding closed	40
6.2.3	Checking and cleaning	40
6.2.4	Safety components	41
6.2.5	Checking the air and gas pressure on the combustion head	41
6.3	Opening the burner	42
6.4	Closing the burner	42
A	Appendix - Accessories	43
B	Appendix - Electrical panel layout.....	44

1 Information and general warnings

1.1 Information about the instruction manual

1.1.1 Introduction

The instruction manual supplied with the burner:

- is an integral and essential part of the product and must not be separated from it; it must therefore be kept carefully for any necessary consultation and must accompany the burner even if it is transferred to another owner or user, or to another system. If the manual is lost or damaged, another copy must be requested from the Technical Assistance Service of the area;
- is designed for use by qualified personnel;
- offers important indications and instructions relating to the installation safety, start-up, use and maintenance of the burner.

Symbols used in the manual

In some parts of the manual you will see triangular DANGER signs. Pay great attention to these, as they indicate a situation of potential danger.

1.1.2 General dangers

The **dangers** can be of **3 levels**, as indicated below.



Maximum danger level!
This symbol indicates operations which, if not carried out correctly, cause serious injury, death or long-term health risks.



This symbol indicates operations which, if not carried out correctly, may cause serious injury, death or long-term health risks.



This symbol indicates operations which, if not carried out correctly, may cause damage to the machine and/or injury to people.

1.1.3 Other symbols



DANGER: LIVE COMPONENTS
This symbol indicates operations which, if not carried out correctly, lead to electric shocks with lethal consequences.



DANGER: FLAMMABLE MATERIAL
This symbol indicates the presence of flammable materials.



DANGER: BURNING
This symbol indicates the risks of burns due to high temperatures.



DANGER: CRUSHING OF LIMBS
This symbol indicates the presence of moving parts: danger of crushing of limbs.



WARNING: MOVING PARTS
This symbol indicates that you must keep limbs away from moving mechanical parts; danger of crushing.



DANGER: EXPLOSION
This symbol signals places where an explosive atmosphere may be present. An explosive atmosphere is defined as a mixture - under atmospheric conditions - of air and flammable substances in the form of gases, vapours, mist or dust in which, after ignition has occurred, combustion spreads to the entire unburned mixture.



PERSONAL PROTECTION EQUIPMENT
These symbols indicate the equipment that must be worn and kept by the operator for protection against threats against safety and/or health while at work.



OBLIGATION TO ASSEMBLE THE HOOD AND ALL THE SAFETY AND PROTECTION DEVICES
This symbol signals the obligation to reassemble the hood and all the safety and protection devices of the burner after any maintenance, cleaning or checking operations.



ENVIRONMENTAL PROTECTION
This symbol gives indications for the use of the machine with respect for the environment.



IMPORTANT INFORMATION
This symbol indicates important information that you must bear in mind.

- This symbol indicates a list.

Abbreviations used

Ch.	Chapter
Fig.	Figure
Page	Page
Sec.	Section
Tab.	Table

1.1.4 Delivery of the system and the instruction manual

When the system is delivered, it is important that:

- the instruction manual is delivered to the user by the system manufacturer, with the recommendation to keep it in the room where the heat generator is to be installed.
- The instruction manual shows:
 - the serial number of the burner;

.....

- the address and telephone number of the nearest Assistance Centre.

.....

- The system supplier must carefully inform the user about:
 - the use of the system;
 - any further tests that may be required before activating the system;
 - maintenance, and the need to have the system checked at least once a year by a representative of the manufacturer or another specialised technician. To ensure a periodic check, the manufacturer recommends the drawing up of a Maintenance Contract.

1.2 Guarantee and responsibility

The manufacturer guarantees its new products from the installation date, in accordance with the regulations in force and/or the sales contract. At the moment of the first start-up, check that the burner is integral and complete.



WARNING

Failure to observe the information given in this manual, operating negligence, incorrect installation and carrying out of non authorised modifications will result in the annulment by the manufacturer of the guarantee that it supplies with the burner.

In particular, the rights to the guarantee and the responsibility will no longer be valid, in the event of damage to things or injury to people, if such damage/injury was due to any of the following causes:

- incorrect installation, start-up, use and maintenance of the burner;
- improper, incorrect or unreasonable use of the burner;
- intervention of unqualified personnel;
- carrying out of unauthorised modifications on the equipment;
- use of the burner with safety devices that are faulty, incorrectly applied and/or not working;
- installation of untested supplementary components on the burner;
- powering of the burner with unsuitable fuels;
- faults in the fuel supply system;
- use of the burner even following an error and/or an irregularity;
- repairs and/or overhauls incorrectly carried out;
- modification of the combustion chamber with inserts that prevent the regular development of the structurally established flame;
- insufficient and inappropriate surveillance and care of those burner components most likely to be subject to wear and tear;
- the use of non-original components, including spare parts, kits, accessories and optional;
- force majeure.

The manufacturer furthermore declines any and every responsibility for the failure to observe the contents of this manual.

2 Safety and prevention

2.1 Introduction

The burners have been designed and built in compliance with current regulations and directives, applying the known technical rules of safety and envisaging all the potential danger situations. It is necessary, however, to bear in mind that the imprudent and clumsy use of the equipment may lead to situations of death risk for the user or third parties, as well as the damaging of the burner or other items. Inattention, thoughtlessness and excessive confidence often cause accidents; the same applies to tiredness and sleepiness.

It is a good idea to remember the following:

- The burner must only be used as expressly described. Any other use should be considered improper and therefore dangerous.

In particular:

it can be applied to boilers operating with water, steam, diathermic oil, and to other users expressly named by the manufacturer; the type and pressure of the fuel, the voltage and frequency of the electrical power supply, the minimum and maximum deliveries for which the burner has been regulated, the pressurisation of the combustion chamber, the dimensions of the combustion chamber and the room temperature must all be within the values indicated in the instruction manual.

- Modification of the burner to alter its performance and destinations is not allowed.
- The burner must be used in exemplary technical safety conditions. Any disturbances that could compromise safety must be quickly eliminated.
- Opening or tampering with the burner components is not allowed, apart from the parts requiring maintenance.
- Only those parts envisaged by the manufacturer can be replaced.



The manufacturer guarantees safety and proper functioning only if all burner components are intact and positioned correctly.

2.2 Personnel training

The user is the person, body or company that has acquired the machine and intends to use it for the specific purpose. He is responsible for the machine and for the training of the people working around it.

The user:

- undertakes to entrust the machine exclusively to suitably trained and qualified personnel;
- undertakes to inform his personnel in a suitable way about the application and observance of the safety instructions. With that aim, he undertakes to ensure that everyone knows the use and safety instructions for his own duties;
- Personnel must observe all the danger and caution indications shown on the machine.
- Personnel must not carry out, on their own initiative, operations or interventions that are not within their province.
- Personnel must inform their superiors of every problem or dangerous situation that may arise.
- The assembly of parts of other makes, or any modifications, can alter the characteristics of the machine and hence compromise operating safety. The manufacturer therefore declines any and every responsibility for any damage that may be caused by the use of non-original parts.

In addition:



- the user must take all the measures necessary to prevent unauthorised people gaining access to the machine
- the user must inform the manufacturer if faults or malfunctioning of the accident prevention systems are noticed, along with any presumed danger situation
- personnel must always use the personal protective equipment envisaged by legislation and follow the indications given in this manual

3 Technical description of the burner

3.1 Burner designation

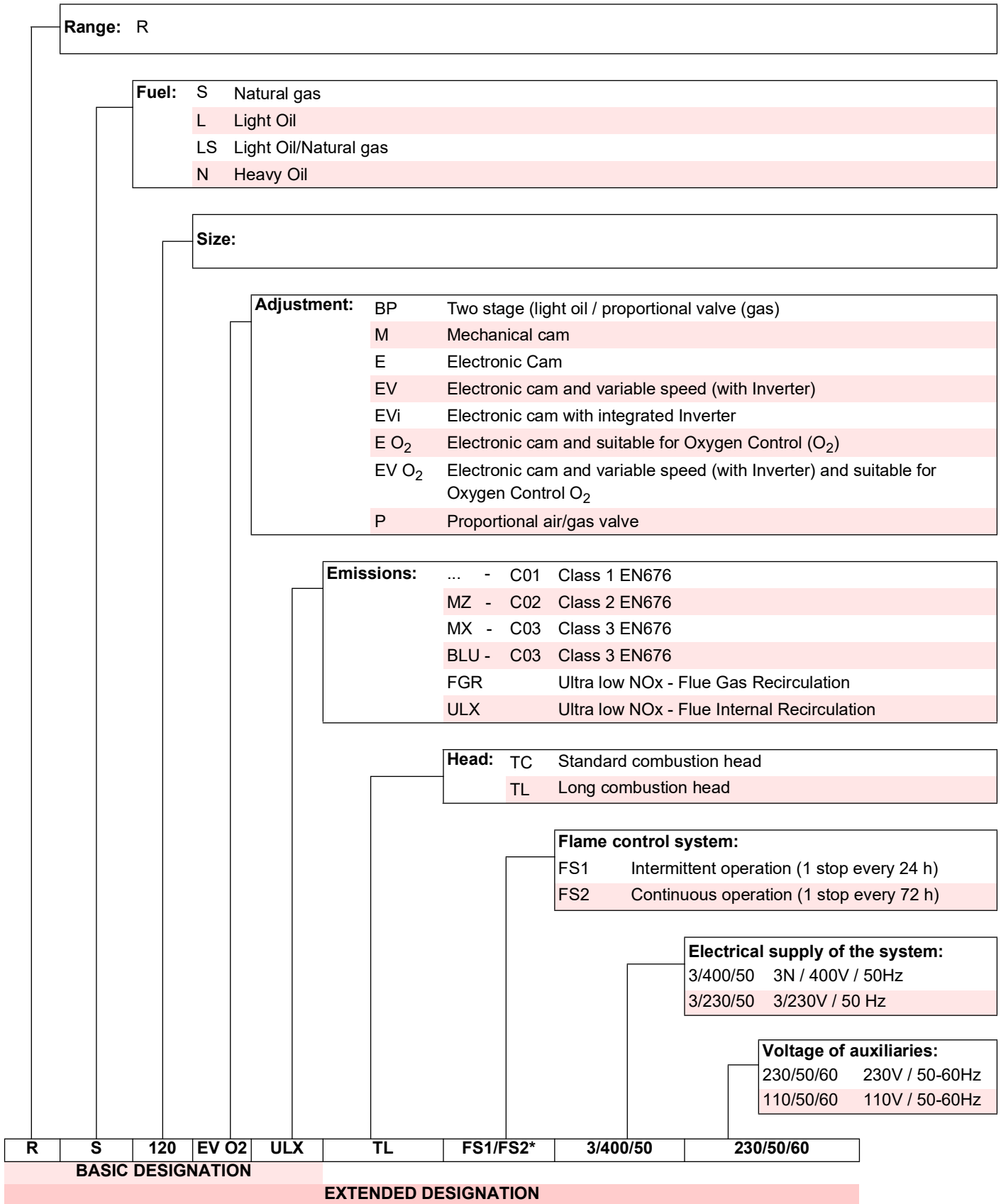

*The burner leaves the factory set up for FS1 operation. If FS2 operation is required, refer the specific manual to LMV 5...

3.2 Models available

Designation			Voltage	Start-up	Code
RS 68/EV O2 ULX	TL	FS2	3 ~ 400V - 50Hz	Inverter	20205437
RS 120/EV O2 ULX	TL	FS2	3 ~ 400V - 50Hz	Inverter	20205438
RS 160/EV O2 ULX	TL	FS2	3 ~ 400V - 50Hz	Inverter	20205439
RS 200/EV O2 ULX	TL	FS2	3 ~ 400V - 50Hz	Inverter	20205441

Tab. A

3.3 Burner categories

Country of destination	Gas category
LU,PL	I2E
BE	I2E(R)
NL	I2EK
DE	I2ELL
FR	I2Er
AT-BG-CH-CZ-DK-EE-ES-FI-GB-GR-HU-IE-IS-IT-LT-LV-NO PT- RO-SE-SI-SK-TR	I2H

Tab. B

3.4 Technical data

Model			RS 68/EV O2 ULX	RS 120/EV O2 ULX	RS 160/EV O2 ULX	RS 200/EV O2 ULX
Type			S041T2	S042T2	S043T2	S044T2
Output (1)	Max. Min.	kW	150/350 - 1050	200/610-1400	290/950-1950	370/1350-2400
Fuel	Natural gas: G20 (methane gas) G25					
Operation	– FS2: Continuous (min. 1 stop in 72 hours)					
Standard applications	Boilers: water, steam, diathermic oil					
Ambient temperature	°C		0 - 40			
Combustion air temperature	°C max		60			
Noise levels (2)	Sound pressure	dB(A)	80.5	83	80.5	83
	Sound power		91.5	94	91.5	94
Weight	kg		67	70	100	104

Tab. C

- (1) Reference conditions: Room temperature 20°C - Gas temperature 15°C - Barometric pressure 1013 mbar - Altitude 0 m above sea level.
 (2) Sound pressure measured in manufacturer's combustion laboratory, with burner operating on test boiler and at maximum rated output. The sound power is measured with the "Free Field" method, as per EN 15036, and according to an "Accuracy: Category 3" measuring accuracy, as set out in EN ISO 3746.

3.5 Electrical data

Model		RS 68/EV O2 ULX	RS 120/EV O2 ULX	RS 160/EV O2 ULX	RS 200/EV O2 ULX
Main electrical supply	3 ~ 400V +/-10% 50Hz				
Control circuit power supply	1N ~ 230V +/-10% 50Hz				
Absorbed electrical power	kW max	2.1	2.9	5.5	6.5
Protection level	IP 44				

Tab. D

3.6 Maximum dimensions

The dimensions of the burner are shown in Fig. 1.

The dimensions of the open burner are indicated by position U.

Bear in mind that inspection of the combustion head requires the burner to be opened and the rear part drawn back on the guides.

20209033

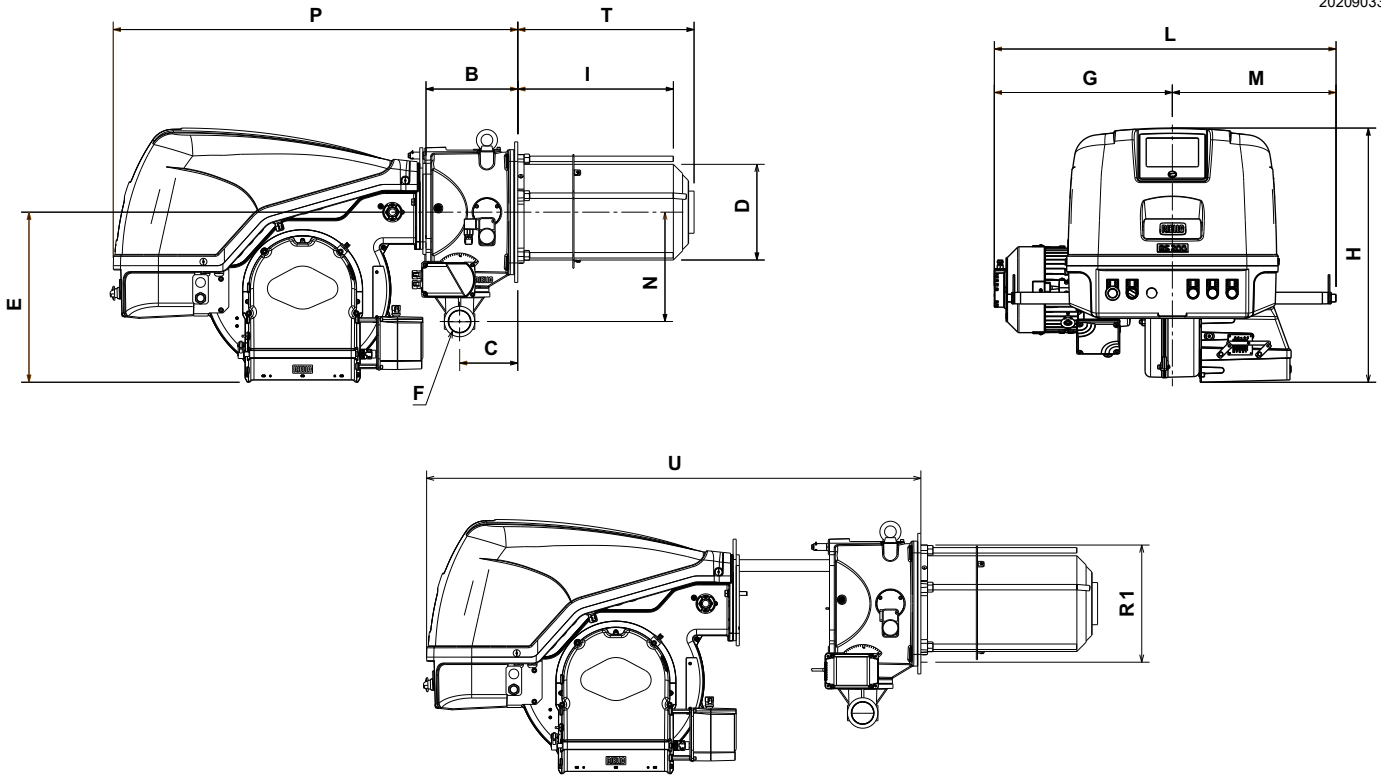

Fig. 1

mm	B	C	D	E	F	G	H	I	L	M	N	P	R1	T	U
RS 68	234	149	189	425	2"	330.35	607	330	567	236	260	861	240	374	1245
RS 120	234	149	189	425	2"	356.35	607	330	593	236	260	861	240	374	1245
RS 160	234	149	245	436	2"	407.58	646	400	712.08	305	280	877	300	453	1446
RS 200	234	149	245	436	2"	455.5	646	400	760	305	280	877	300	453	1446

Tab. E

3.7 Burner equipment

- Gas train flange No. 1
- Gasket for gas train flange No. 1
- Thermal flange gasket No. 1
- Screws M10x40 to fix the gas train flange No. 4
- Screws M16x50 to fix the burner flange to the boiler No. 4
- Central gas discs regulator No. 2
- Lifting eyebolts No. 2
- Slide bars extension (only for RS 200/EV O2 ULX model) No. 2
- GW 500 gas pressure switch No. 1
- Instructions No. 1
- Spare parts list No. 1



It is recommended to tighten the screws of the gas flange with a tightening torque of **30 Nm ±10%**.

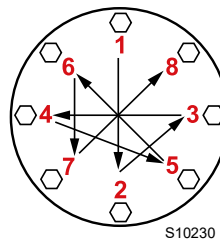

Tighten the nuts gradually (first to 30%, then to 60% up to 100%) according to the cross pattern shown in the figure.



To use the GW 500 gas pressure switch (supplied as equipment) refer to the paragraphs **"Firing rates"** on page 9 e **"Maximum gas pressure switch"** on page 37.

3.8 Firing rates

The **maximum output** must be higher than the following values (Tab. F):

Model	kW
RS 68/EV O2 ULX	350
RS 120/EV O2 ULX	600
RS 160/EV O2 ULX	950
RS 200/EV O2 ULX	1350

Tab. F



If the chosen maximum output is exactly equal to these values (Tab. F), the central gas calibration must be modified (see “**Central gas adjustment**” on page 23).

If the chosen maximum output is higher than the following values (Tab. G):

Model	kW
RS 68/EV O2 ULX	750
RS 120/EV O2 ULX	1175
RS 160/EV O2 ULX	1320
RS 200/EV O2 ULX	1600

Tab. G



replace the GW 150 maximum pressure switch (Fig. 7 on page 12) installed on the burner with the GW500 gas pressure switch supplied as equipment.

The **minimum output** must not be lower than the minimum limit of the diagram (Fig. 2, Fig. 3, Fig. 4 and Fig. 5).



The firing rate was obtained considering a room temperature of 20°C and an atmospheric pressure of 1013 mbar (approx. 0 m above sea level), with the combustion head adjusted as shown at page 24.

RS 68/EV O2 ULX

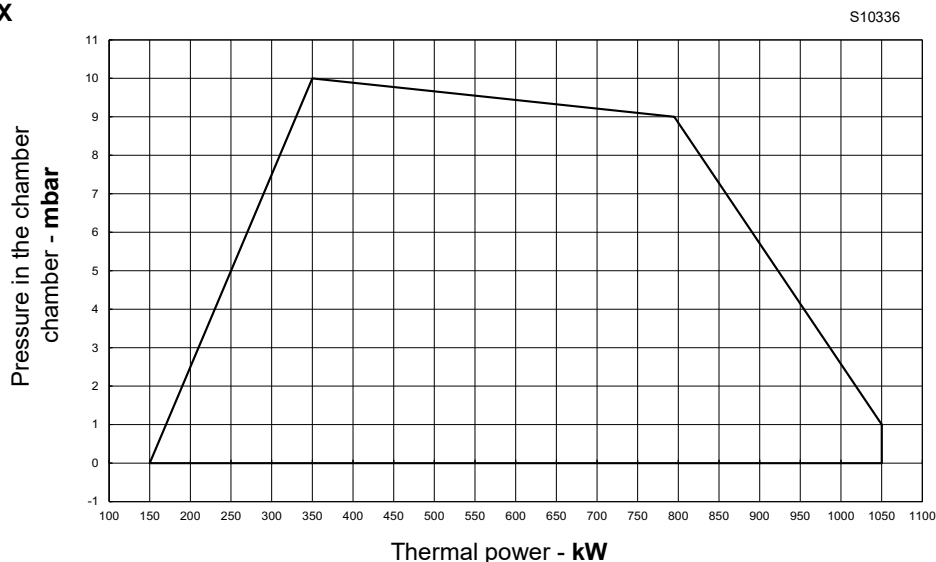

Fig. 2

RS 120/EV O2 ULX

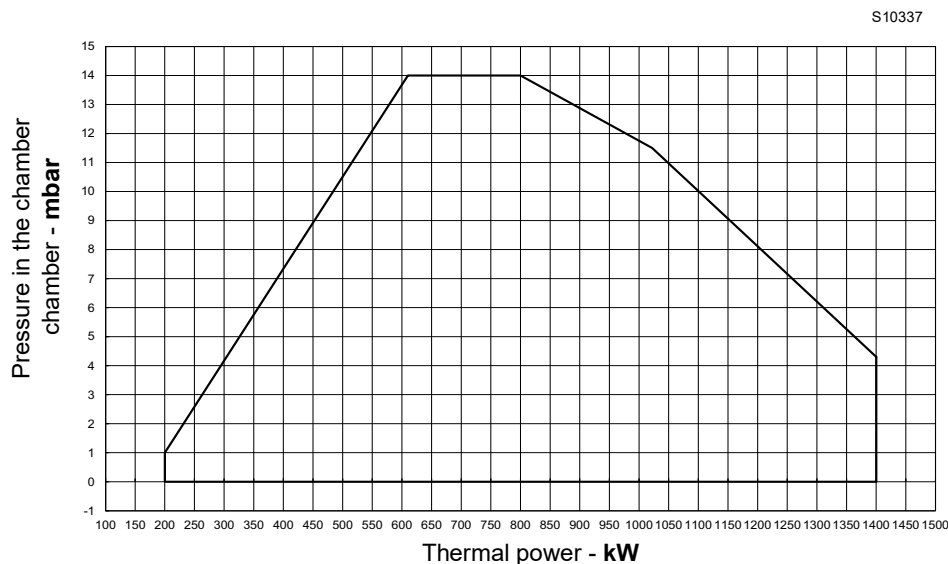

Fig. 3

RS 160/EV O2 ULX

S10340

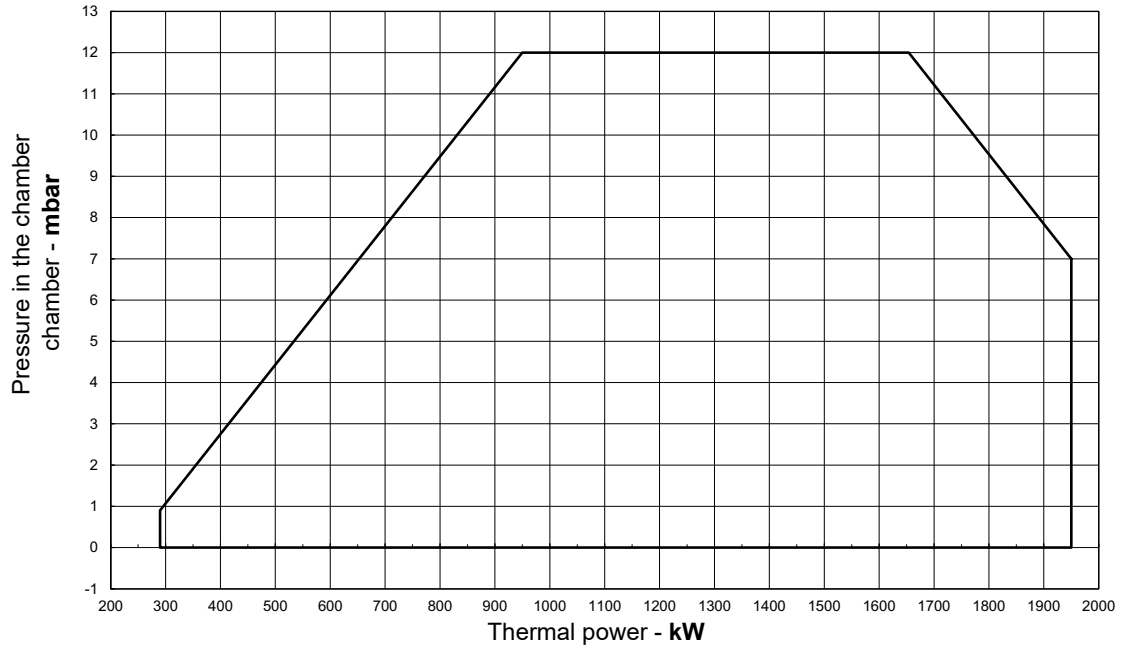

Fig. 4

RS 200/EV O2 ULX

S10341

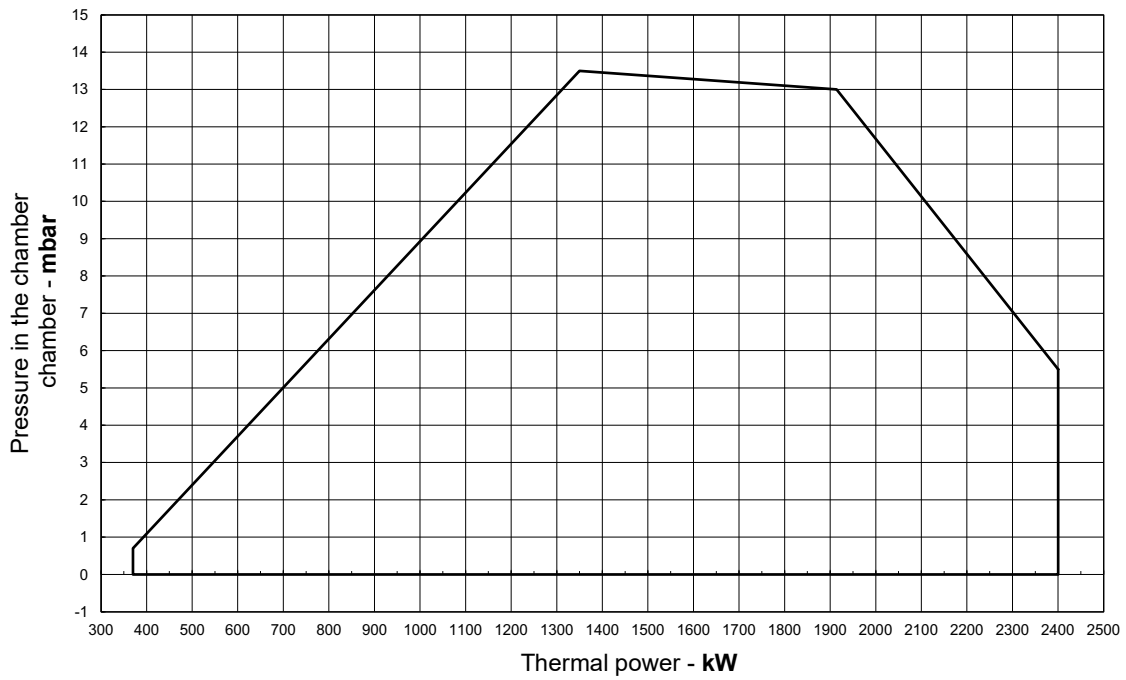

Fig. 5

3.9 Test boiler

The firing rates were obtained in special test boilers, according to EN 676 standard. In Fig. 6 you can see the diameter and length of the test combustion chamber.

Although combination is guaranteed when boiler has a CE type-approval, preliminary tests are recommended for boilers or furnaces having a combustion chamber size much different than the one specified in Fig. 6.

Example:

Output 756 kW (650 Mcal/h) - diameter 60 cm, length 2 m.

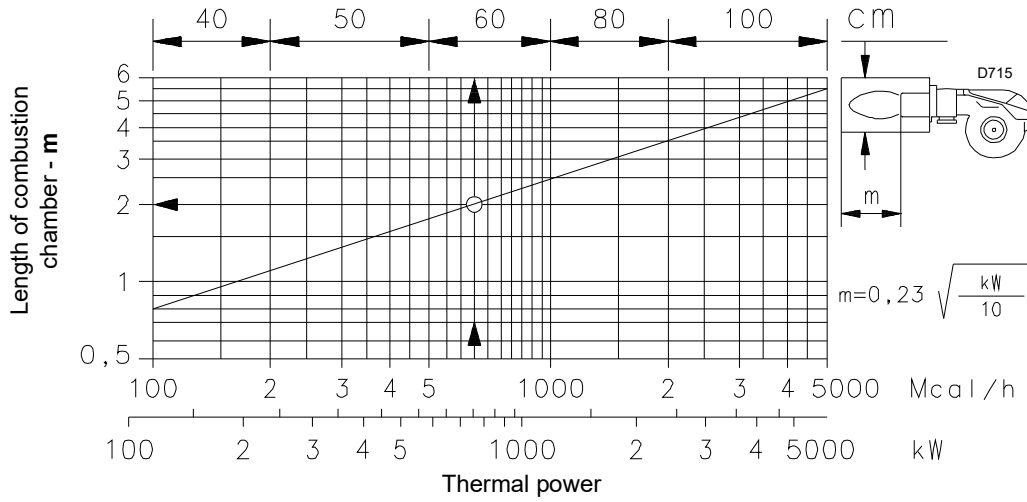

Fig. 6

3.10 Burner description

20209069

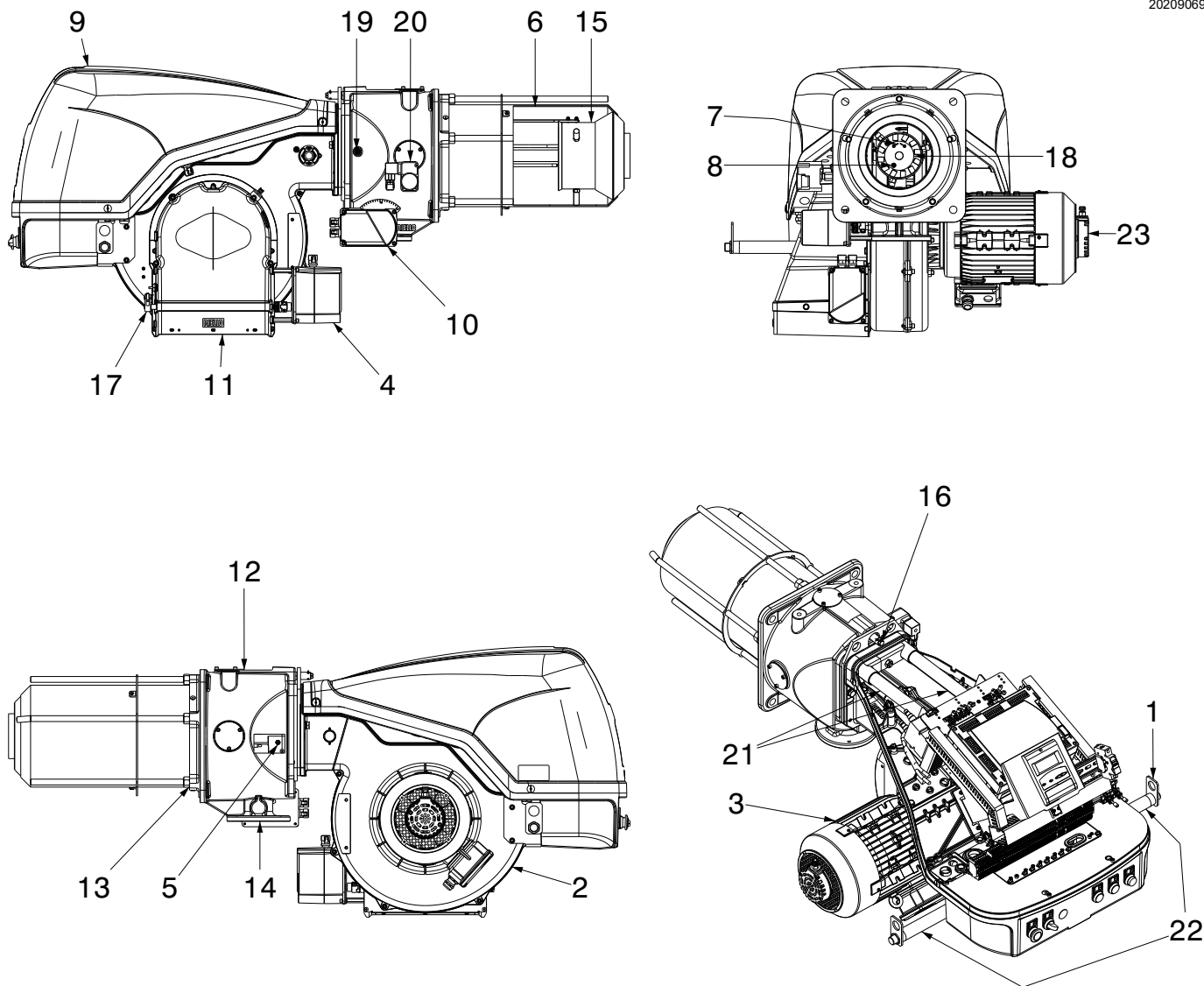

Fig. 7

- 1 Lifting rings
- 2 Fan
- 3 Fan motor
- 4 Air damper servomotor
- 5 Combustion head gas pressure test point
- 6 Combustion head
- 7 Ignition electrodes
- 8 Ionisation probe
- 9 Electrical panel cover
- 10 Gas butterfly valve servomotor
- 11 Fan air inlet
- 12 Pipe coupling
- 13 Gasket for boiler fixing
- 14 Gas butterfly valve
- 15 Shutter
- 16 Combustion head movement screw
- 17 Lever for controlling the dampers with graduated scale
- 18 Flame stability disk
- 19 Combustion head air pressure test point
- 20 Maximum gas pressure switch with pressure test point
- 21 Slide bars for opening the burner and inspecting the combustion head
- 22 Extensions for slide bars
- 23 Motor revolution sensor



Wait for the components in contact with heat sources to cool down completely.

3.11 Electrical panel description

20209092

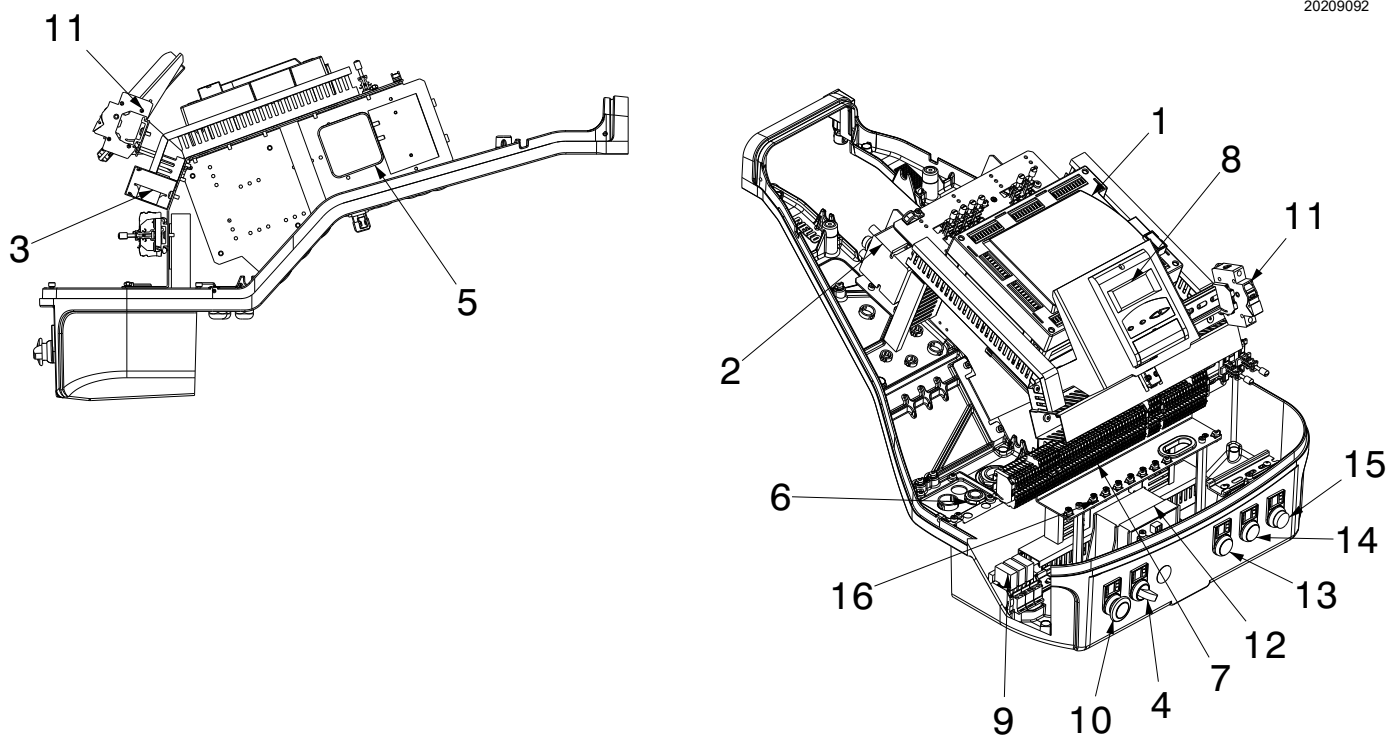

Fig. 8

- 1 Flame control
- 2 Ignition transformer
- 3 Suppressor
- 4 Operation switch **"ON/OFF"**
- 5 Air pressure switch (differential type)
- 6 Cable grommets for electrical connections to be carried out by the installer
- 7 Terminal board for electrical connections
- 8 Operator panel with LCD display
- 9 Relay with clean contacts
- 10 Button **"EMERGENCY STOP"**
- 11 Auxiliary fuses
- 12 Transformer of flame control **"T1"**
- 13 Light signalling **"POWER ON"**
- 14 Light signalling **"OVERLOAD FAN MOTOR"**
- 15 Light signalling burner lockout and reset button
- 16 Earth screws

3.12 Flame control

Warnings



To avoid accidents, material or environmental damage, observe the following instructions!

The flame control is a safety device! Avoid opening or modifying it, or forcing its operation. Riello S.p.A. cannot assume any responsibility for damage resulting from unauthorised interventions!

Risk of explosion!

An incorrect configuration can provoke fuel overcharging, with the consequential risk of explosion! Operators must be aware that incorrect settings made on the AZL5... display and operating unit and incorrect settings of the fuel and / or air actuator positions can lead to dangerous burner operating conditions.

- All interventions (assembly and installation operations, assistance, etc.) must be carried out by qualified personnel.
- Before modifying the wiring in the flame control connection area, fully disconnect the system from the power supply (omnipolar separation). Check the system is not powered and cannot be accidentally reconnected. Failure to do this will lead to the risk of electrocution.
- Protection against electrocution from the LMV5... and all connected electric components is obtained with correct assembly.
- Before any intervention (assembly and installation operations, assistance, etc.), ensure the wiring is in order and that the parameters are correctly set, then make the safety checks.
- Falls and collisions can negatively affect the safety functions.
In this case, the must not be operated, even if it displays no evident damage.
- In programming mode, the position check of actuators and VSD (checking electronic fuel / air ratio control) is different from the check during automatic operation. As for automatic operation, the actuators are guided together to the positions requested and, if an actuator does not reach the position requested, adjustments are made until the position is actually reached. However, in contrast to automatic operation, there are no time limits to these corrective actions. The other actuators maintain their positions until all actuators have reached the positions currently required. This is absolutely important to set the fuel / air ratio control system.
During the time the fuel / air ratio curves are being programmed, the person making the plant settings must continuously monitor the quality of the combustion process (e.g. by means of a flue gas analyser). Also, if combustion levels are poor, or in the event of dangerous situations, the commissioning engineer must take appropriate action (e.g. switching off manually).

To ensure the safety and reliability of the LMV5... system, the following instructions must also be followed:

- avoid conditions that can favour the development of condensate and humidity. Otherwise, before switching on again, make sure that the entire is perfectly dry!
- Static charges must be avoided since they can damage the 's electronic components when touched.



D9301

Fig. 9

Mechanical structure

The LMV5... is a system to check the burners, based on a micro-processor and equipped with components to adjust and monitor medium and large capacity forced draught burners. The base of the LMV5... system incorporates the following components:

- Burner adjustment device with system for checking the seal of the gas valves
- Electronic fuel/air ratio monitoring device with a maximum of 6 (LMV52...) actuators
- Optional PID temperature / pressure controller (load controller)
- Optional VSD module Mechanical design.

Electrical connection of flame sensor

It is important for signal transmission to be almost totally free of any disturbances or loss:

- always separate the detector cables from the other cables:

- Line capacitance reduces the magnitude of the flame signal.
- Use a separate cable.

- Respect the allowed cable lengths.

Technical data

Flame control base	Mains voltage	AC 230V -15% / +10%	
	Mains frequency	50 / 60 Hz ±6 %	
	Power absorption	< 30W (normal)	
	Safety class	I, with components in compliance with II and III, according to DIN EN 60730-1	
Load on 'input' terminals	F1 unit fuse (internal)	6.3 AT	
	Main fuse of perm. network (external)	Max. 16 AT	
	Undervoltage		
	• Safety switch-off from operating position to mains voltage	< AC 186 V	
	• Restart when mains voltage picks up	> AC 188 V	
	Oil pump / magnetic clutch (nominal voltage)		
	• Nominal current	2A	
• Power factor	cosφ > 0.4		
Air pressure switch test valve (nominal voltage)	• Nominal current	0.5A	
	• Power factor	cosφ > 0.4	
	Load on 'output' terminals	Total load on the contacts:	
		• Mains voltage	AC 230 V -15 % / +10 %
• Total unit input current (safety circuit) load on contacts due to:		Max. 5 A	
– Fan motor contactor			
– Ignition transformer			
– Valve			
– Oil pump / magnetic clutch			
Cable lengths	Single contact loading:		
	Fan motor contactor (nominal voltage)		
	• Nominal current	1A	
	• Power factor	cosφ > 0.4	
	Alarm output (nominal voltage)		
	• Nominal current	1A	
	• Power factor	cosφ > 0.4	
	Ignition transformer (nominal voltage)		
	• Nominal current	2A	
	• Power factor	cosφ > 0.2	
	Fuel gas valve (nominal voltage)		
	• Nominal current	2A	
• Power factor	cosφ > 0.4		
Fuel oil valve (nominal voltage)			
• Nominal current	1A		
• Power factor	cosφ > 0.4		
Environmental conditions	Operation	DIN EN 60721-3-3	
	Climatic conditions	Class 3K3	
	Mechanical conditions	Class 3M3	
	Temperature range	-20...+60°C	
	Humidity	< 95% RH	

Tab. H

3.13 Actuator

Warning notes



WARNING

To avoid injury to persons, damage to property or the environment, the following warning notes should be observed!

Do not open, interfere with or modify the actuators!

- All activities (mounting, installation and service work, etc.) must be performed by qualified staff.
- Before making any wiring changes in the connection area of the actuator, completely isolate the burner control from the mains supply (all-polar disconnection).
- Ensure protection against electric shock hazard by providing adequate protection for the connection terminals and by securing the housing cover.
- Check to ensure that wiring is in an orderly state.
- Fall or shock can adversely affect the safety functions. Such units must not be put into operation, even if they do not exhibit any damage.



WARNING

The housing cover may only be removed for short periods of time for wiring or when making the addressing.

It must be made certain that dust or dirt will not get inside the actuator while such work is carried out.

Use

The actuator (Fig. 10) is used to drive and position the air damper and the gas butterfly valve, without mechanical lever-ages but via the interposition of an elastic coupling.

When used in connection with burner controls or electronic fuel / air ratio control, the associated controlling elements are controlled depending on burner output.

Installation notes

- Always run the high-voltage ignition cables separate from the unit and other cables while observing the greatest possible distance.
- The holding torque is reduced when the actuator's power supply is switched off.



WARNING

When servicing or replacing the actuator, take care not to invert the connectors.

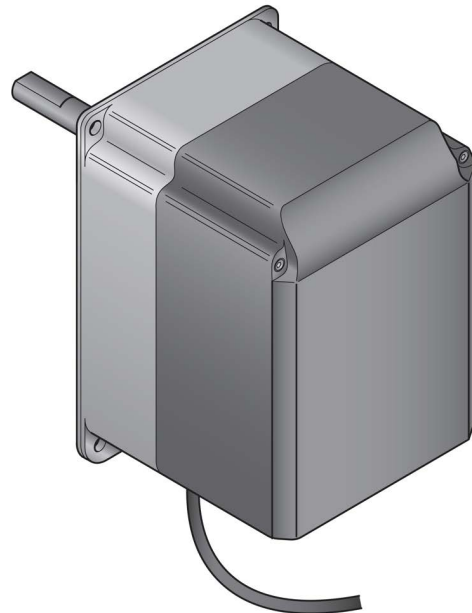

D8271

Fig. 10

Technical data

Model	SQM45.295A9
Operating voltage	AC 2 x 12 V via bus cable from the basic unit or via a separate transformer
Safety class	Extra low-voltage with safe isolation from mains voltage
Power consumption	9...15 VA
Degree of protection	To EN 60 529, IP 54, provided adequate cable entries are used
Electrical connections	RAST3.5 terminals
Direction of rotation (when facing the shaft)	- Standard: counterclockwise - Reverse: clockwise
Running time (min.) for 90°	10 s.
Holding torque (max.)	1.5 Nm
Nominal torque (max.)	3 Nm
Weight	approx. 1 kg
Environmental conditions:	
Operation	DIN EN 60721-3-1
Climatic conditions	class 1K3
Mechanical conditions	class 1M2
Temperature range	-20...+60 °C
Humidity	< 95 % r.h.

Tab. I



WARNING

Condensation, the formation of ice and the entry of water are prohibited!

3.14 PLL52... module (optional)

Warnings



To avoid accidents, material or environmental damage, observe the following instructions!

Avoid opening, modifying or forcing the device.

- All interventions (assembly and installation operations, assistance, etc.) must be carried out by qualified personnel.
- Falls and collisions can negatively affect the safety functions. In this case, the unit must not be operated, even if it displays no evident damage.

Assembly notes

- Check the relevant national safety standards are respected.

3.14.1 Terminal ratings, cable lengths and cross-sectional areas

Cable lengths / cross-sectional areas	
Electrical connection "X89"	Screw terminals up to max. 2.5 mm ²
Cable lengths	≤ 10 m fino a QGO20...
Cross-sectional areas	Refer to description of QGO20...
Analog inputs	
Air temperature detector	Pt1000 / LG-Ni1000
Flue gas temperature	Pt1000 / LG-Ni1000
QGO20...	Refer to data sheet N7842
Interface	Communication bus for LMV52...

Tab. J



Fig. 11

Technical data

Model	PLL52...
Mains voltage "X89-01"	AC 230 V -15%/10%
Safety class	I class with parts according to II class (DIN EN 60730-1)
Mains frequency	50 / 60 Hz ±6 %
Power consumption	Ca. 4 VA
Degree protection	IP54, housing closed
Transformer AGG5.220	
- Primary side	AC 230V
- Secondary side	AC 12 V (3x)
Environmental conditions:	
Storage	DIN EN 60721-3-1
Climatic conditions:	Class 1K3
Mechanical conditions:	Class 1M2
Temperature range:	-20...+60 °C
Humidity:	<95% r.h.
Transport	DIN EN 60721-3-2
Climatic conditions:	Class 2K2
Mechanical conditions:	Class 2M2
Temperature range:	-25...+70 °C
Humidity:	<95% r.h.
Operation	DIN EN 60 721-3-1
Climatic conditions:	Class 3K5
Mechanical conditions:	Class 3M2
Temperature range:	-20...+60 °C
Humidity:	< 95% r.h.

Tab. K

NOTE:

For detailed information, refer to the specific manual of PLL52 module.



Condensation, formation of ice and the entrance of water are not permitted!

3.15 Oxygen sensor QGO20 ... (optional)

Warnings



WARNING

To avoid accidents, material or environmental damage, observe the following instructions!

Avoid opening, modifying or forcing the oxygen sensor.

- All interventions (assembly and installation operations, assistance, etc.) must be carried out by qualified personnel.
- Before modifying the wiring in the sensor connection area, fully disconnect the burner control device from the power supply (omnipolar separation).
- Ensure that the sensor cannot be inadvertently switched on again and check this by making a voltage test.
- To avoid the risk of electrocution, protect the connection terminals in a suitable manner and correctly fix the cover.
- During operation, the flange of the sensor connection must be kept closed; all screws must be tightened securely.
- Check the wiring is in order.
- Falls and collisions can negatively affect the safety functions. In this case, the unit must not be operated, even if it displays no evident damage.
- Ensure that the device does not get into contact with explosive or inflammable gases.
- There is a risk of burning since the measuring cell works at an operating temperature of 700 °C and other accessible parts can get very hot too (> 60 °C).
- To prevent injury caused by the hot immersion tube, remove the device only after the equipment has cooled down.
- Make certain that the sensor's inlet and outlet are always kept free from dirt.
- Before cleaning the inlet and outlet, allow the sensor to cool down for at least 1 hour.
- Mount the sensor such that the connecting part (head to flange) is free so that the exchange of air is ensured. Otherwise, measurements might get distorted, possibly leading to dangerous situations.
- Ensure that there are no chemicals, such as solvent vapors, near the sensor.

Installation notes

- The flue gas flow passing the measuring cell must be homogeneous, with no or only little turbulence. When mounted too close to air dampers or pipe bends, faulty measurements can occur.
- A number of faults can distort the measurements (this can lead to dangerous situations in connection with oxygen trim control):
 - If the stack is not tight, false air can join the flue gases.
 - In that case, the residual oxygen content indicated by the sensor is higher than it actually is.
 - If the flue gas velocity is low, the sensor's response is slower, since the flue gases take more time to pass the measuring cell. In that case, it is recommended to mount the sensor in an inclined position (refer to the manual).
 - The greater the sensor's distance from the flame, the longer the dead time.

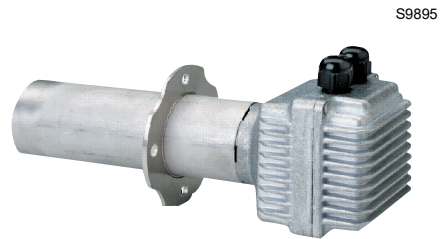

Fig. 12

NOTE:

For further explanations about the wiring connections, please refer to the manual supplied with the accessory code 20045187.



WARNING

Condensation, formation of ice and the entrance of water are not permitted!

3.15.1 Technical data QGO20

Operating voltage of measuring cell's:	
– QGO20.000D27	AC 230 V ±15 %
– QGO20.000D17	AC 120 V ±15 % (only with LMV52 ... with PLL52...)
Mains frequency:	50...60 Hz ±6 %
Power consumption:	Max. 90 W, typical value 35 W (controlled)
Permissible mounting position:	Refer to mounting Instructions M7842
Degree of protection:	IP40, to be ensured through installation
Weight (net):	approx. 0.9 kg
Signal lines	
– Shielded 6-wires cable	Twisted pairs
– Shielding connected to terminal GND of the PL52...	
Wire diameter	LiFCY3x2x0,2 o LYCY3x2x0,2
Measuring system	Zirconium dioxide measuring cell as an oxygen ion conductor
Permissible flue gas velocity (only with AGO20...)	1...10 m/s
Fuel type	Fuel oil EL or Natural gas H
Measuring range	0.2...20.9 % O ₂
Permissible cable length	Max. 100 m
Wire diameter	<10 m
Power supply lines (Net cable)	Min. 1 mm ²
– Cable diameter	QGO20.000D27: e.g. NYM 3 x 1,5
– Cable type	QGO20.000D17: UL AWM Style 1015/MTW or CSA-AWM/TEW
Required operating temperature of measuring cell	700 °C ±50 °C
Environmental conditions	
Storage	DIN EN 60721-3-1
Climatic conditions:	Class 1K3
Mechanical conditions:	Class 1M2
Temperature range:	-20...+60 °C
Humidity:	<95% r.h.
Transport	DIN EN 60721-3-2
Climatic conditions:	Class 2K2
Mechanical conditions:	Class 2M2
Temperature range:	-25...+70 °C
Humidity:	<95% r.h.
Operation	DIN EN 60721-3-3
Climatic conditions:	Class 3K5
Mechanical conditions:	Class 3M2
Temperature range:	
– Flange	Max. 250 °C
– Connecting head	Max. 70 °C
– Flue gases	≤300 °C
Humidity:	<95% r.h.
Installation altitude:	Max. 2000 m a.s.l.

Tab. L

4.4 Operating position



- The burner is designed to operate only in positions 1, 2, 3 and 4 (Fig. 14).
- Installation 1 is preferable, as it is the only one that allows the maintenance operations as described in this manual.
- Installations 2, 3 and 4 permit operation but make maintenance and inspection of the combustion head more difficult.



- Any other position could compromise the correct operation of the appliance.
- Installation 5 is prohibited for safety reasons.

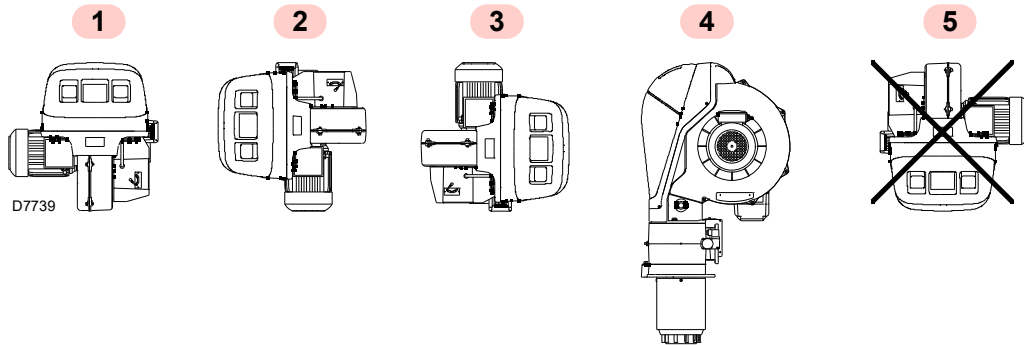

Fig. 14

4.5 Preparing the boiler

4.5.1 Boring the boiler plate

Pierce the closing plate of the combustion chamber, as in Fig. 15. The position of the threaded holes can be marked using the thermal insulation screen supplied with the burner.

4.5.2 Blast tube length

The length of the blast tube must be greater than the thickness of the boiler door complete with its fettling.

For boilers with front flue passes 13)(Fig. 16), a protection in refractory material 11) must be inserted between the boiler fettling 12) and the blast tube 11).

The refractory can have a conical shape (minimum 60°).

This protective fettling must not compromise the extraction of the blast tube.

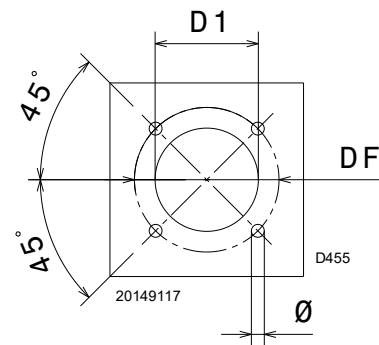

Fig. 15



For RS 160... and RS 200... burners, the hole in the boiler refractory must be at least 320 mm.

mm	D1	DF	Ø
RS 68/EV O2 ULX	260	325	M 16
RS 120/EV O2 ULX	260	325	M 16
RS 160/EV O2 ULX	305	368	M 16
RS 200/EV O2 ULX	305	368	M 16

Tab. M

4.6 Securing the burner to the boiler



Provide an adequate lifting system of the burner.

Divide the combustion head from the rest of the burner, as shown in Fig. 16; you have to:

- loosen the 4 screws 3) and remove the cover 1);
- remove screws 2) from the two slide bars 5);
- disconnect connector of gas servomotor;
- disconnect the socket of the maximum gas pressure switch 14);
- remove the 2 screws 4);
- draw the burner back on the slide bars 5) by about 100 mm;
- disconnect the electrode and ionisation probe cables, then completely slide out the burner from the slide bars.
- Fix the flange 9) to the plate of the boiler interposing the insulating flange gasket 8) supplied with the unit.
- Use the 4 screws supplied, with a tightening torque of 35 ± 40 Nm, after protecting their thread with anti-seizing products.

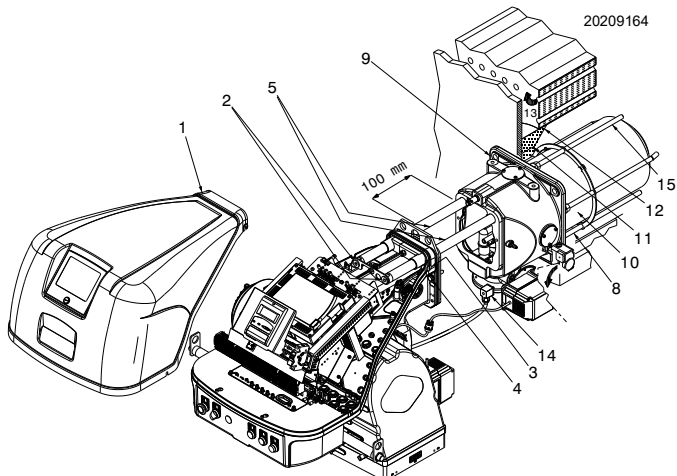

Fig. 16



The burner-boiler seal must be hermetic; after burner start-up check there is no leakage of flue gases into the external environment.



Pay particularly attention to the external gas pipes 15 (Fig. 16) during the burner fixing to the boiler in order to avoid to damage them.

4.7 Access to head internal part

In order to extract the combustion head, proceed as follows:

- unscrew the nuts 1) (Fig. 17);
- extract the internal part 2) of the combustion head.

To reassemble the combustion head, carry out the operations in reverse, tightening the nut 1) at the end.

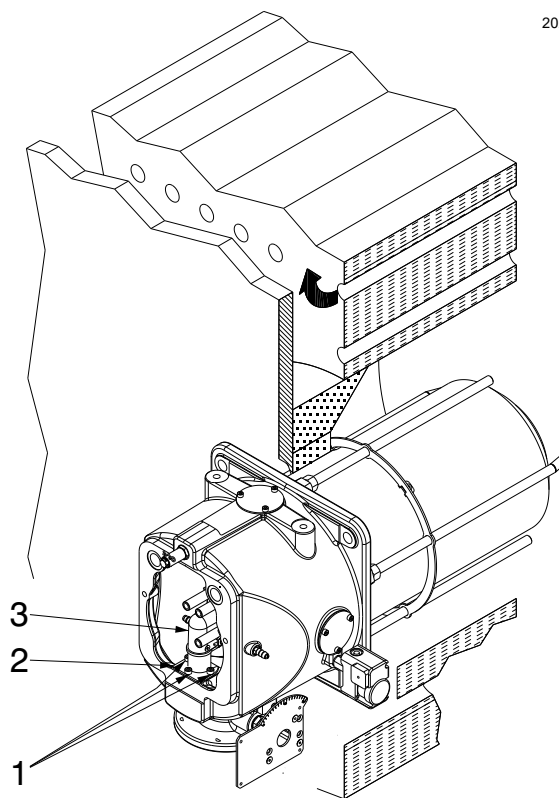

20205164

Fig. 17

4.8 Electrode position



Before fixing the burner to the boiler, check the correct positioning of the electrodes as in Fig. 18.

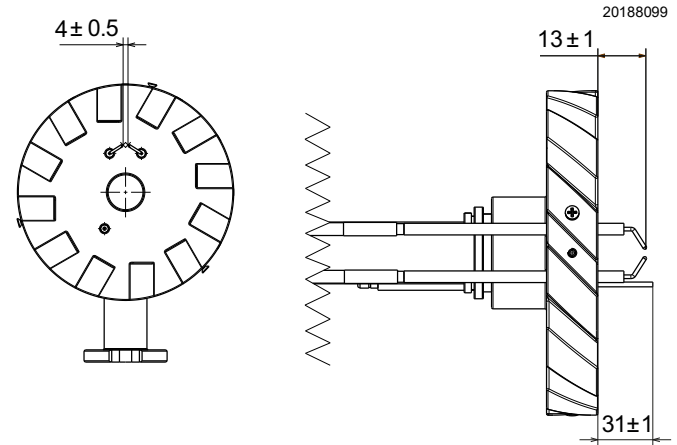

Fig. 18

4.9 Central gas adjustment

As you can see in Fig. 19 the gas flows through the combustion head in two different ways:

- external gas flows from the pipes 1) that surround the head;
- central gas flows from the tube 2) and then through the plates 3) behind the flame disc.

4.9.1 Central gas setting

The factory setting for the central gas is with the following passage holes of the disc 1) in Fig. 20.

RS 68/EV O2 ULX	7 mm
RS 120/EV O2 ULX	10.5 mm
RS 160/EV O2 ULX	8 mm
RS 200/EV O2 ULX	9 mm

If necessary, modify as indicated in the paragraph "Firing rates" on page 9 and replace the disc 1) as follows:

- loosen the screws 2);
- change the regulator disc 1) with the one supplied as equipment for the following models:

RS 68/EV O2 ULX	8 mm
RS 120/EV O2 ULX	12.4 mm
RS 160/EV O2 ULX	9 mm
RS 200/EV O2 ULX	12.4 mm

- tighten the screws 2).

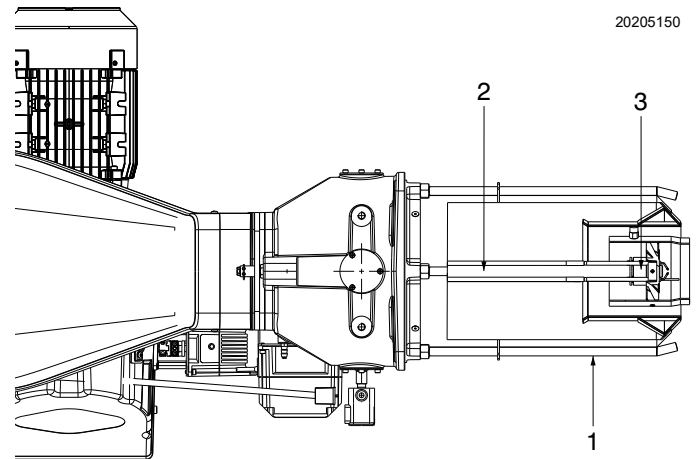

Fig. 19

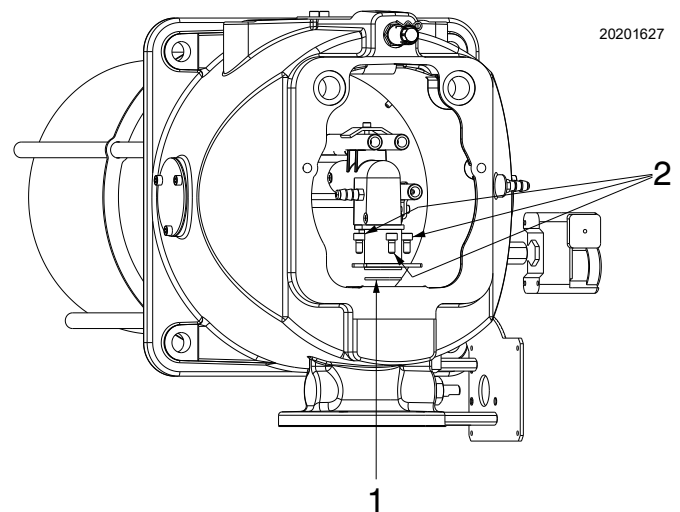

Fig. 20

4.10 Combustion head adjustment

At this point of the installation, the combustion head is fixed to the boiler as shown in Fig. 17 on page 22. It is therefore especially easy to adjust, and this adjustment depends only on the maximum output of the burner.

Turn the screw 1)(Fig. 21) until the notch matches with the front plane 2) of the flange.

The combustion head is opened by turning the screw 1) counter-clockwise.

The combustion head is closed by turning the screw 1) clockwise (Fig. 23 on page 25).



The burner leaves the factory with the combustion head set to notch 0.

This adjustment allows to secure the moving parts during the transport of the burner.

Before the burner start-up, make the adjustments according to the required output and indicated in the diagram (Fig. 22).

NOTE:

The adjustment can be changed according to the specific application.

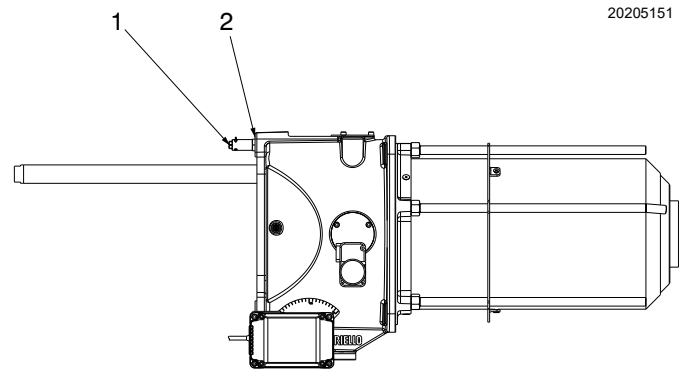
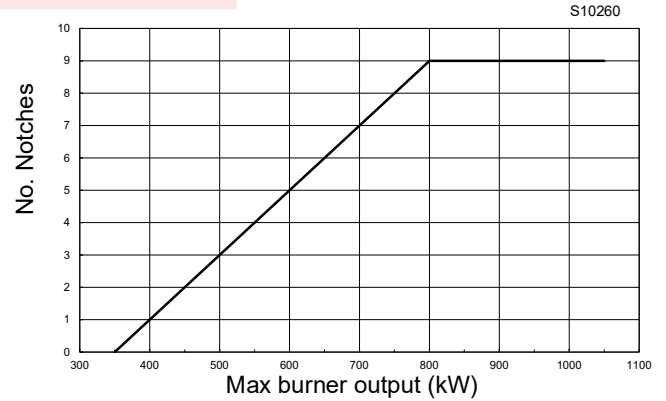
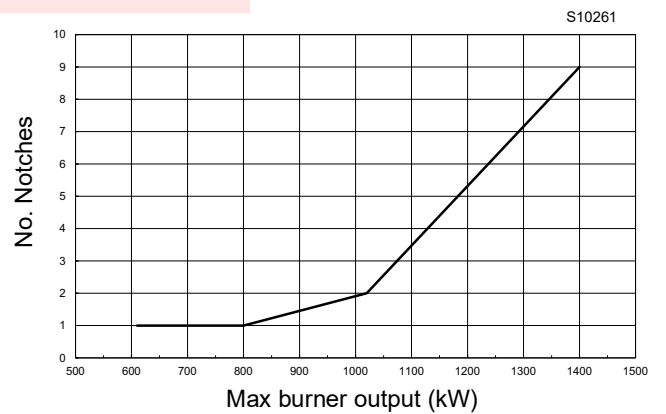

Fig. 21

RS 68/EV O2 ULX



RS 120/EV O2 ULX



RS 160/EV O2 ULX

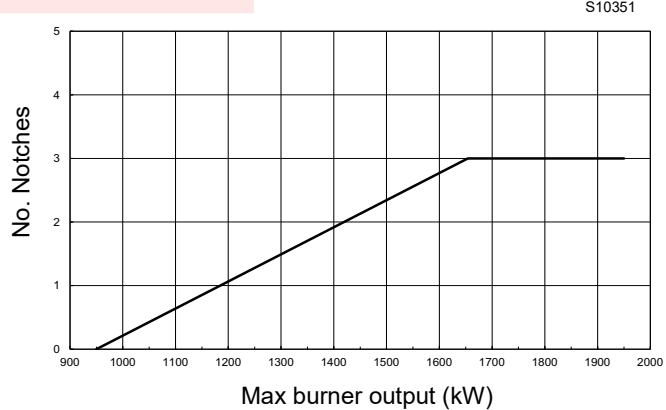

RS 200/EV O2 ULX

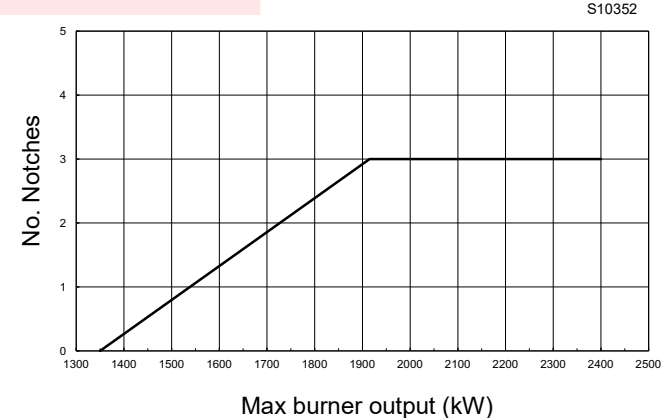

Fig. 22

4.11 Closing the burner

Once the combustion head adjustment is completed:

- reassemble the burner on the slide bars 3) at about 100 mm from the pipe coupling 4) burner in the position shown in Fig. 16 on page 22;
- fit the electrode cable and then slide the burner up to the pipe coupling, the burner in the position indicated in Fig. 23;
- connect the servomotor connector;
- connect the socket of the maximum gas pressure switch;
- refit the screws 2) on the slide bars 3);
- fix the burner to the pipe coupling with the screw 1)(Fig. 23).



WARNING

On closing the burner on the two slide bars, it is advisable to gently pull the high voltage cable outwards until it is slightly taut.

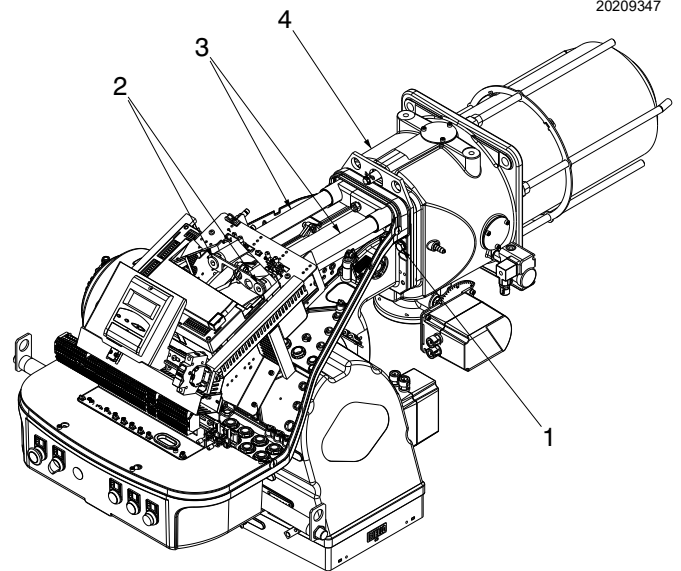

Fig. 23

4.12 Gas feeding



Explosion danger due to fuel leaks in the presence of a flammable source.

Precautions: avoid knocking, attrition, sparks and heat.

Make sure the fuel interception tap is closed before performing any operation on the burner.



The fuel supply line must be installed by qualified personnel, in compliance with current standards and laws.

4.12.1 Gas feeding line (Example) - For functional details refer to the gas train manual

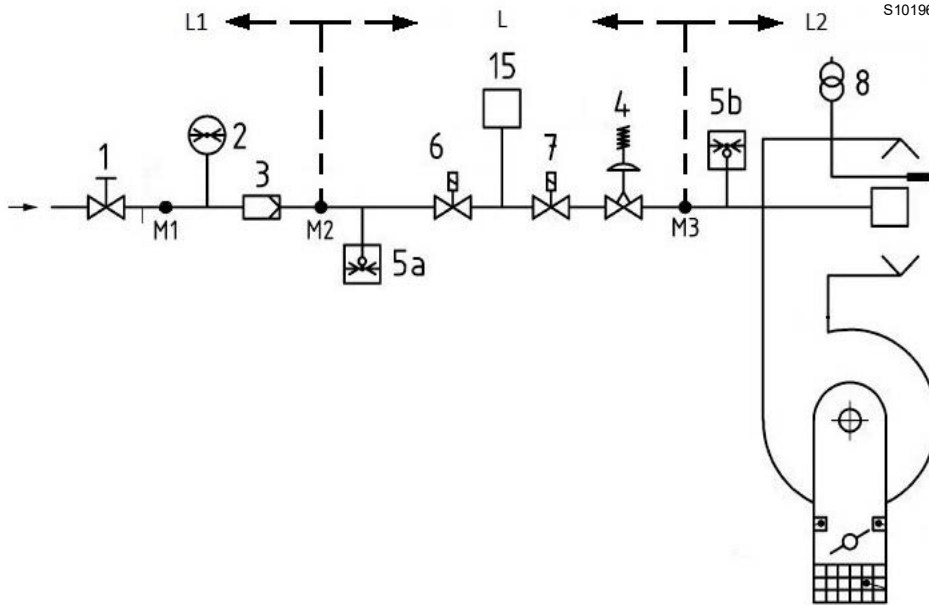

Fig. 24

Key (Fig. 24)

- 1 Manually operated shut-off valve
- 2 Pressure gauge
- 3 Filter
- 4 Governor
- 5a Low pressure protection device
- 5b Max gas pressure switch
- 6 1st safety shut-off valve
- 7 2nd safety shut-off valve
- 8 Ignition device
- 15 Valve proving system
- L Gas train - supplied loose
- L1 Installer responsibility
- L2 Burner
- M1 Pressure outlet
- M2 Pressure outlet
- M3 Pressure outlet

4.12.2 Gas train

Manufactured according to standard EN 676 and provided separately from the burner.

4.12.3 Gas train installation



Disconnect the electrical power using the main switch.



Check that there are no gas leaks.



Pay attention when handling the train: danger of crushing of limbs.



Make sure that the gas train is properly installed by checking for any fuel leaks.



The operator must use the required equipment during installation.

4.12.4 Gas pressure

Each diagram indicate the minimum pressure drops depending on the maximum burner output.

The values shown, refer to:

- Natural gas G 20 NCV 9.45 kWh/Sm³

Calculate the approximate output of the burner in this way:

- subtract the combustion chamber pressure from the gas pressure measured at test point 20)(Fig. 7 on page 12).
- Enter the mbar scale (Fig. 25, Fig. 26, Fig. 27 and Fig. 28) and read the corresponding output by reading on the line.

Example RS 120/EV O2 ULX with G20 natural gas:

Fixed Output operation

Gas pressure at test point P1	=	35 mbar
Pressure in combustion chamber	=	5 mbar
		$35 - 5 = 30$ mbar

A pressure of 30 mbar, corresponds to an output of 750 kW with factory setting for central gas.

Example RS 200/EV O2 ULX with G20 natural gas:

Fixed Output operation

Gas pressure at test point P1	=	108 mbar
Pressure in combustion chamber	=	8 mbar
		$108 - 8 = 100$ mbar

A pressure of 100 mbar, corresponds to an output of 1750 kW with factory setting for central gas.

This value serves as a rough guide; the effective output must be measured at the gas meter.

To calculate the required gas pressure at test point 20)(Fig. 7 on page 12) set the MAX output required from the burner operation:

- find the nearest output value (Fig. 25, Fig. 26, Fig. 27 and Fig. 28).
- Read the pressure at the test point 20)(Fig. 7 on page 12).
- Add this value to the estimated pressure in the combustion chamber.

Example for RS 120/EV O2 ULX with G20 natural gas:

Required burner maximum output operation: 750 kW

Gas pressure at an output of 750 kW	=	30 mbar
Pressure in combustion chamber	=	5 mbar
		$35 + 5 = 35$ mbar

Pressure required at test point 20)(Fig. 7 on page 12).

Example for RS 200/EV O2 ULX with G20 natural gas:

Required burner maximum output operation: 1750 kW

Gas pressure at an output of 1750 kW with factory setting for central gas regulation	=	100 mbar
Pressure in combustion chamber	=	8 mbar
		$100 + 8 = 108$ mbar

Pressure required at test point 20)(Fig. 7 on page 12).



The output and gas pressure data refer to operation with gas butterfly valve fully open (90°) on the whole firing rate.

RS 68/EV O2 ULX

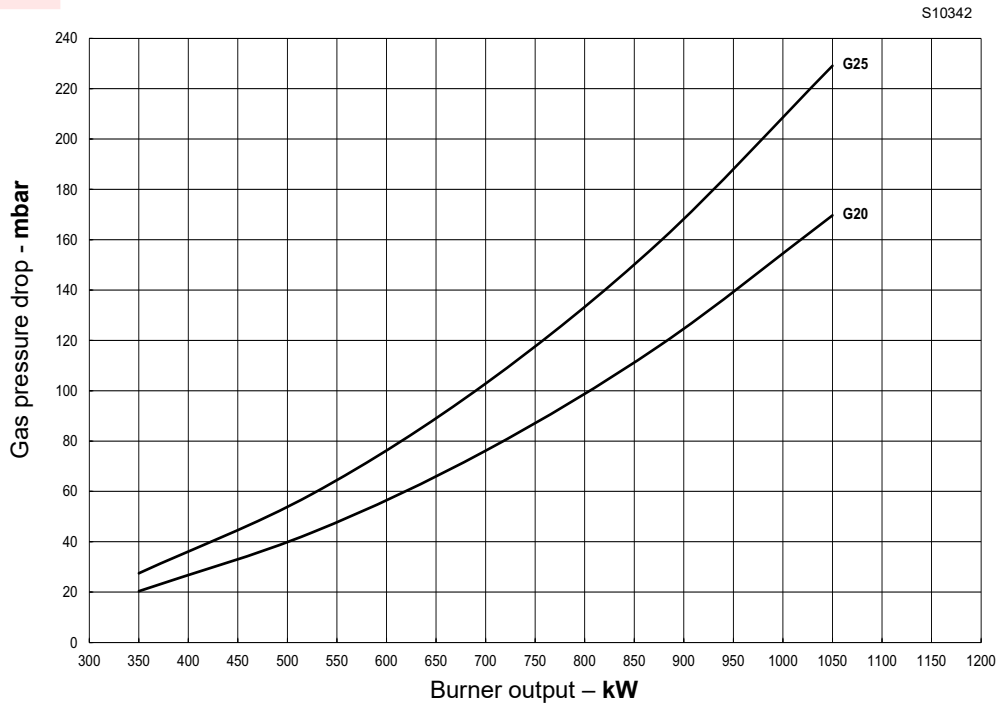

Fig. 25

RS 120/EV O2 ULX

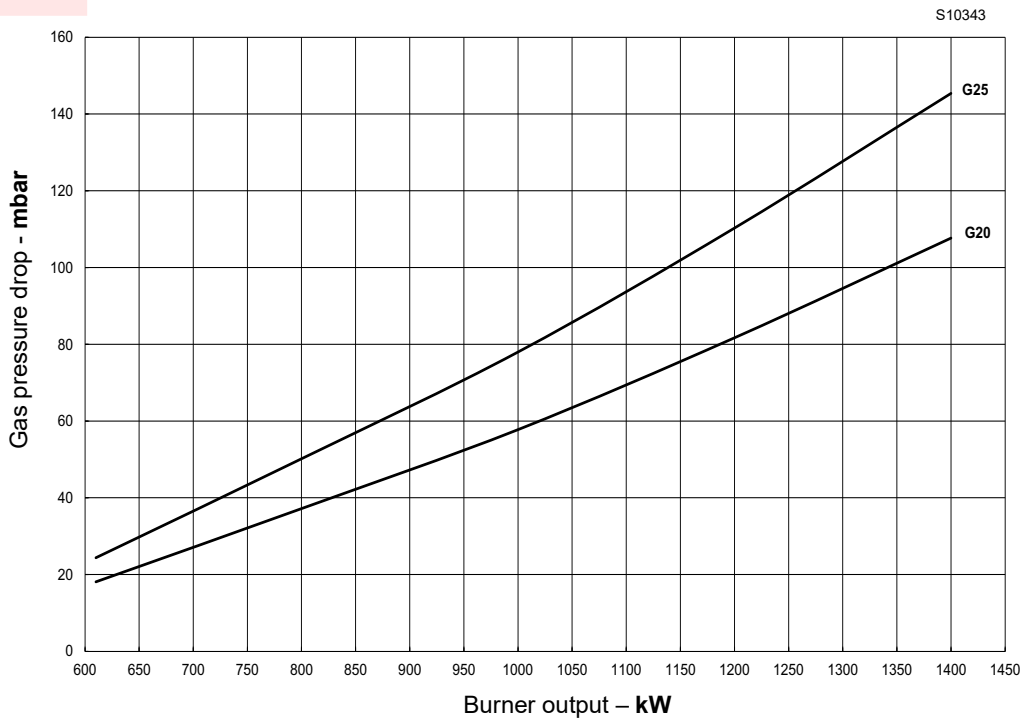

Fig. 26

RS 160/EV O2 ULX

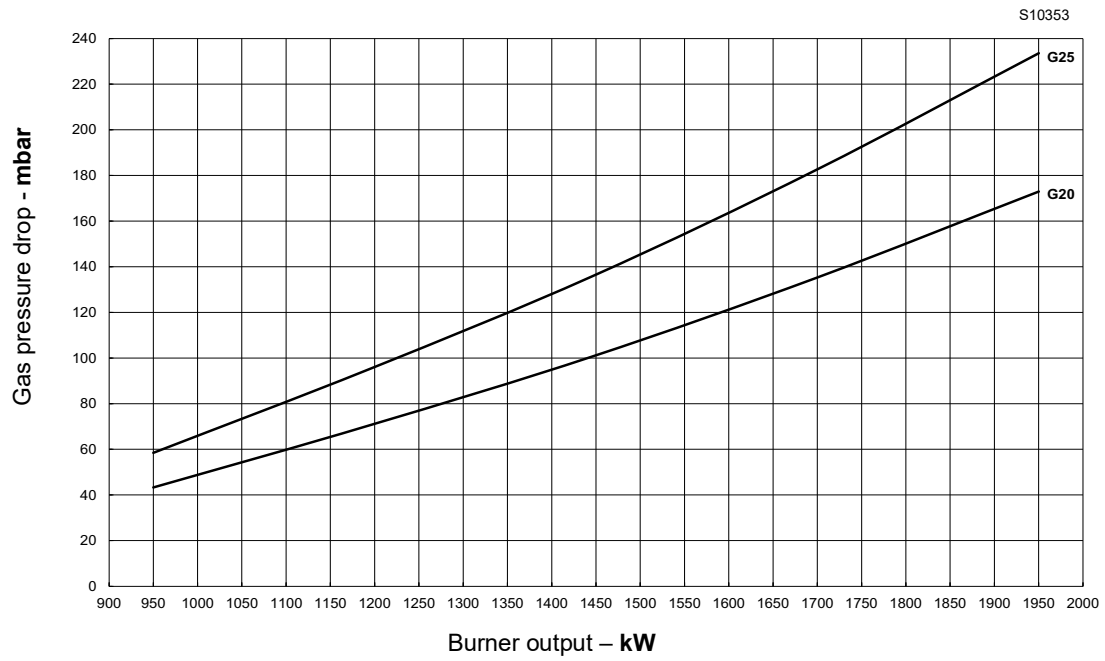

Fig. 27

RS 200/EV O2 ULX

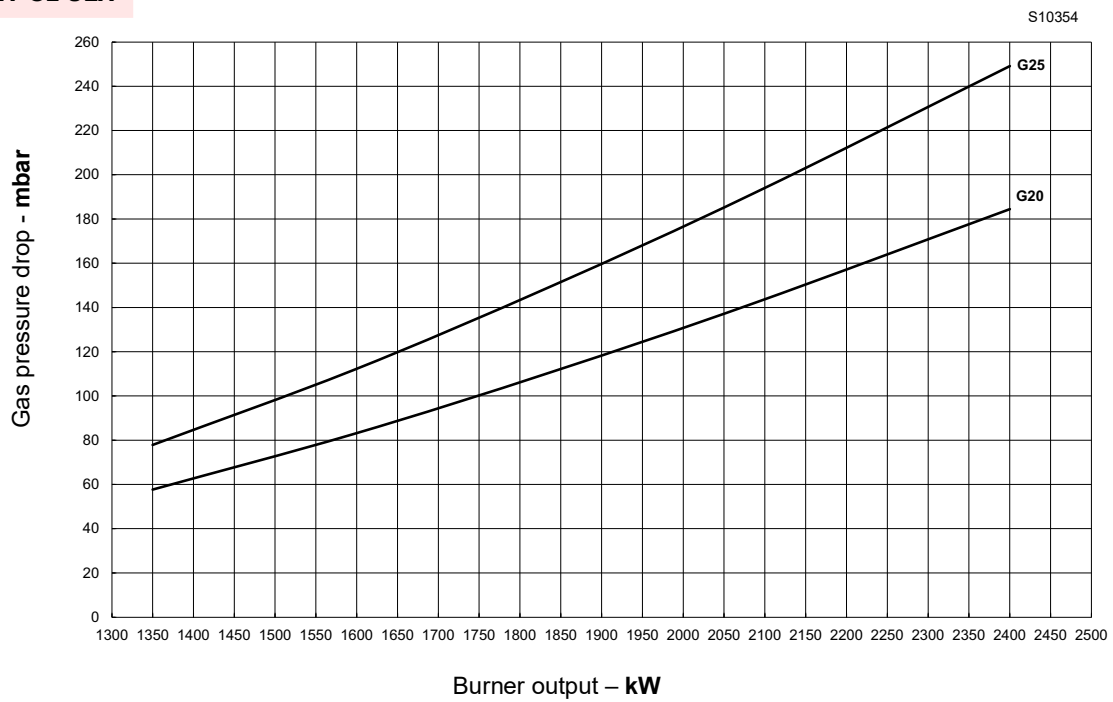

Fig. 28

4.13 Electrical wiring

Notes on safety for the electrical wiring



DANGER

- The electrical wiring must be carried out with the electrical supply disconnected.
- Electrical wiring must be made in accordance with the regulations currently in force in the country of destination and by qualified personnel. Refer to the wiring diagrams.
- The manufacturer declines all responsibility for modifications or connections different from those shown in the wiring diagrams.
- Check that the electrical supply of the burner corresponds to that shown on the identification label and in this manual.
- The burners equipped with LMV5... can operate in FS1 or FS2 mode (continuous/intermittent operation), see specific manual LMV5... . Refer to the following notes for the type of operation that has been set.
- The FS1 burners have been set for intermittent operation. This means that the burner should compulsorily be stopped at least once every 24 hours to enable the electric to check its own safety and efficiency at start-up. Normally the boiler's thermostat/pressure switch ensures that the burner stops. If this is not the case, a time switch should be fitted in series to TL to stop the FS1 burner at least once every 24 hours. Refer to the wiring diagrams.
- The FS2 burners have been set for continuous operation. This means that the burner should compulsorily be stopped at least once every 72 hours to enable the electric to check its own safety and efficiency at start-up. Normally, burner stopping is guaranteed by the boiler's thermostat/pressure switch. If this is not the case, a time switch should be fitted in series to TL to stop the FS2 burner at least once every 72 hours. Refer to the wiring diagrams.
- The electrical safety of the device is obtained only when it is correctly connected to an efficient earthing system, made according to current standards. It is necessary to check this fundamental safety requirement. In the event of doubt, have the electrical system checked by qualified personnel. Do not use the gas tubes as an earthing system for electrical devices.
- The electrical system must be suitable for the maximum power absorption of the device, as indicated on the label and in the manual, checking in particular that the section of the cables is suitable for that level of power absorption.
- For the main power supply of the device from the electricity mains:
 - do not use adapters, multiple sockets or extensions;
 - use a multiple pole switch with at least a 3 mm gap between the contacts (overvoltage category III), as envisaged by the present safety standards.
- Do not touch the device with wet or damp body parts and/or in bare feet.
- Do not pull the electric cables.
- Check the electric wiring inside the boiler complies with the national and local safety regulations.
- Live and neutral should not be mixed up (this could cause dangerous malfunctions, a loss of protection against electric shocks, etc..).
- Make sure the cable grommets of the connected cables comply with the relevant standards (e.g. EN60730 and EN60 335).
- When wiring the unit, make sure that AC 230V mains voltage cables are run strictly separate from extra low-voltage cables to avoid risks of electrical shock hazard.

Before carrying out any maintenance, cleaning or checking operations:



DANGER

Disconnect the electrical supply from the burner by means of the main system switch.



DANGER

Close the fuel interception tap.



DANGER

Avoid condensate, ice and water leaks from forming.

If the hood is still present, remove it and proceed with the electrical wiring according to the wiring diagrams.

Use flexible cables in compliance with the EN 60 335-1 standard.

4.13.1 Supply cables and external connections passage

All the cables to be connected to the burner must be threaded through cable grommets. The use of the cable grommets can take various forms; by way of example see Fig. 29.

Key (Fig. 29)

- 1 Electrical supply - Bore for M32
- 2 Consents and safety devices - Bore for M20
- 3 Minimum gas pressure switch - Bore for M20
- 4 VPS gas valve leak detection control kit- Bore for M20
- 5 Gas train - Bore for M20
- 6 Available - Bore for M20
- 7 Available - Bore for M16
- 8 Available - Bore for M32

Cable grommets used in the factory:

- A Rpm sensor
- B Maximum gas pressure switch
- C Servomotors



After carrying out maintenance, cleaning or checking operations, reassemble the cover and all the safety and protection devices of the burner.

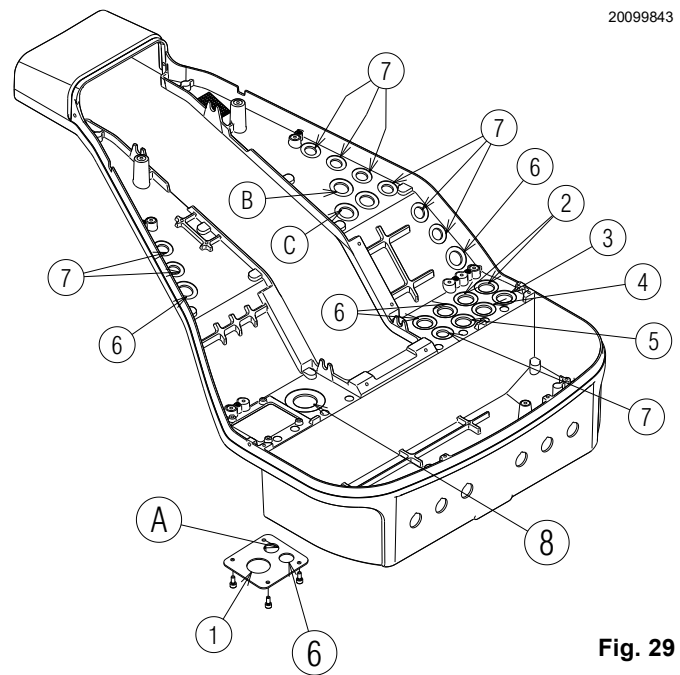

Fig. 29

4.13.2 Motor cable shield



WARNING

It is very important to shield the motor cable 1) as shown in Fig. 30.

The connection from the Inverter to flame control must be done as shown in Fig. 30.

Key (Fig. 30)

- 1 Motor supply cable
- 2 Single phase supply cable
- 3 Connection from the inverter to LMV52...

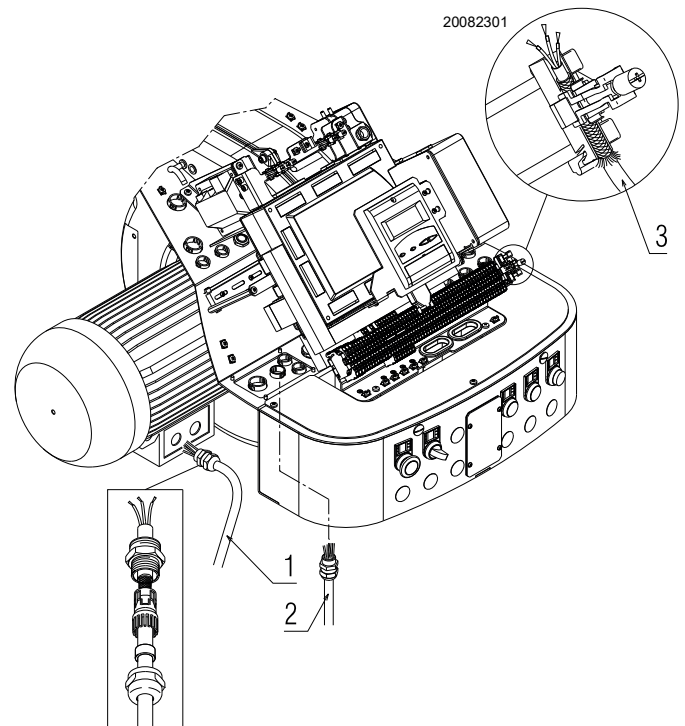

Fig. 30

4.14 Adjustment fan motor covering with external rpm

To calibrate the rpm sensor 6)(Fig. 31), proceed as follows:

- remove the cover 1) unscrewing the screws 2);
- unscrew or screw the nuts 3) - 5) and the rpm detection disc 4) so that its distance from the rpm sensor 6) is about 2 mm.;
- place the plate 4) on the nut 5) and fix with the lock nut 3);
- close the cover 1) by screwing the screws 2).

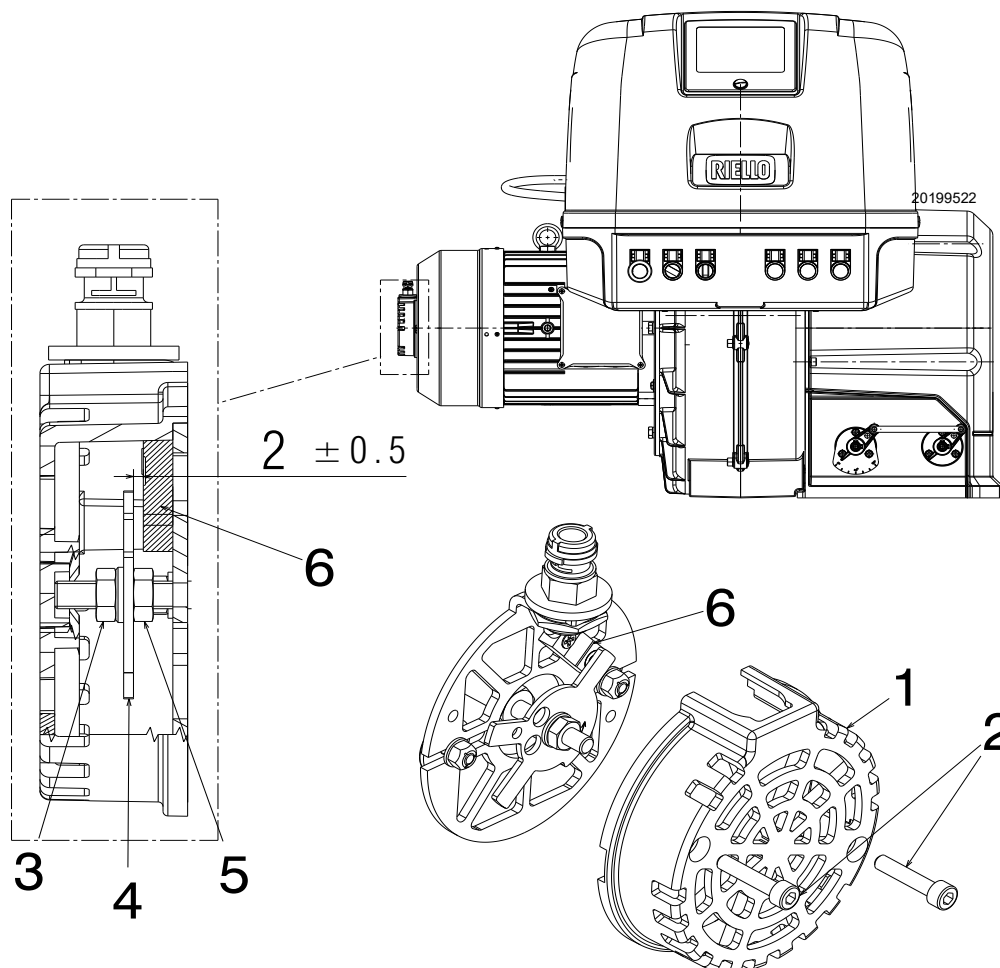

Fig. 31

Key (Fig. 31)

- 1 - Cover
- 2 - Screws for cover fixing
- 3 - Lock nut
- 4 - Rpm detection disc
- 5 - Lower nut
- 6 - Rpm sensor

5 Start-up, calibration and operation of the burner

5.1 Notes on safety for the first start-up



The first start-up of the burner must be carried out by qualified personnel, as indicated in this manual and in compliance with the standards and regulations of the laws in force.



Check the correct working of the adjustment, command and safety devices.



Before igniting the burner, see the paragraph "Safety test - with gas feeding closed" on page 40.

5.2 Adjustments prior to ignition

Combustion head adjustment has already been described in the section "**Combustion head adjustment**" on page 24.

In addition, the following adjustments must also be made:

- ensure that the gas supply company has carried out the supply line vent operations, eliminating air or inert gases from the piping.
- Slowly open the manual valves situated upstream of the gas train.
- Adjust the minimum gas pressure switch (Fig. 36 on page 37) to the start of the scale.
- Adjust the maximum gas pressure switch (Fig. 35 on page 37) to the end of the scale.
- Adjust the air pressure switch (Fig. 34 on page 36) to the start of the scale.
- Adjust the pressure switch for the valve leak detection control device (PVP Kit) (Fig. 37 on page 37), if present, according to the instructions supplied with the Kit itself.
- Check the gas supply pressure by connecting a pressure gauge to the pressure test point 1)(Fig. 32) of the minimum gas pressure switch: it must be lower than the maximum allowed pressure of the gas train, as shown on the characteristics label.

- Bleed the air from the piping of the gas train, connecting a plastic tube to the pressure test point 1)(Fig. 26) of the minimum gas pressure switch. Take the vent tube outside the building so you can notice the smell of gas.
- Connect two lamps or testers to the two gas line solenoids to check the exact moment at which voltage is supplied. This operation is unnecessary if each of the two solenoids is equipped with an indicator light that signals voltage passing through.



Before starting up the burner, it is good practice to adjust the gas train so that ignition takes place in conditions of maximum safety, i.e. with gas delivery at the minimum.



An excessive gas pressure can damage the components of the gas train and lead to a risk of explosion.

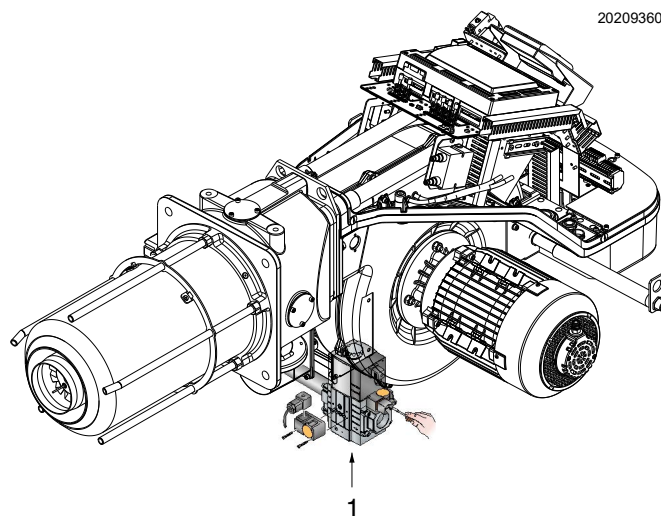

20209360

Fig. 32

5.3 Burner start-up

Feed electricity to the burner via the disconnecting switch on the boiler panel.

Close the thermostats/pressure switches and turn the switch 4)(Fig. 8 on page 13) to position “**(1) - ON**”.



Check that the lamps or testers connected to the solenoid valves, or the pilot lights on the solenoid valves, indicate that no voltage is present.

If they indicate the presence of voltage, stop the burner immediately and check the electric connections.

As the burner is not fitted with a device to check the sequence of the phases, the rotation of the motor may be incorrect.

As soon as the burner starts place yourself in front of the cooling fan of the fan motor and check that it turns anticlockwise. See Fig. 33.

If this is not the case:

- set the switch 4)(Fig. 8 on page 13) to “**(0) - OFF**” and wait until the flame control carries out the switching off phase;
- disconnect the burner from the power supply;
- invert the phases on the three-phase power supply.

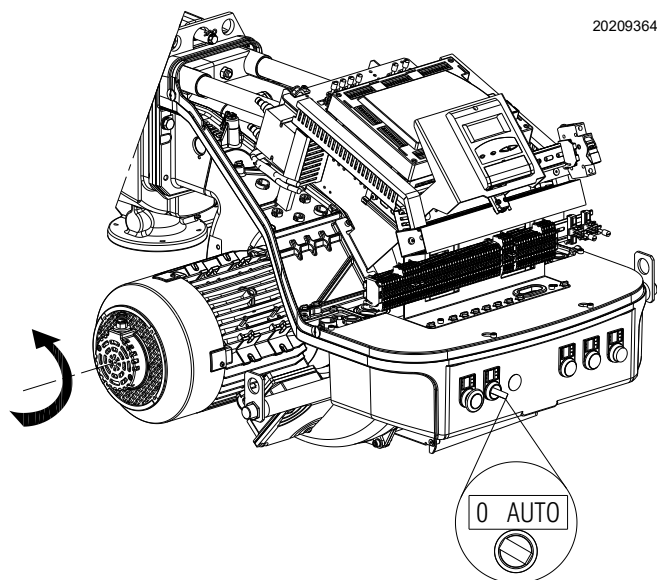

Fig. 33

5.4 Air / fuel adjustment

Air/fuel synchronisation is carried out with the relevant air and gas servomotors by logging a calibration curve by using the electronic cam.

It is advisable, to reduce the loss and for a wide calibration field, to adjust the servomotors to the maximum of the output used, the nearest possible to the maximum opening (90°).

The choking of the air, taking into account the maximum combustion output, takes place by varying the adjustment of the combustion head (see “**Combustion head adjustment**” on page 24).

On the gas butterfly valve, the fuel step according to the burner output required, with servomotor completely open, is carried out by the pressure stabiliser on the gas train.

5.4.1 Air adjustment for maximum output

- Adjust the servomotor to maximum opening (nearly 90°) so that the air butterfly valves are entirely open.

5.4.2 Air/fuel adjustment and output modulation system

The air/gas regulator and output modulation system equipping **RS/E** series burners performs a number of integrated functions to optimise burner function, in both individual installations and in combination with other units (e.g. double furnace boiler or multiple heat generators in parallel).

The basic system functions control:

- 1 The dosage of the air and fuel through positioning using direct servocommands of the relevant valves eliminating the possible play in the calibration systems with mechanical cam lever mechanisms, used on traditional modulating burners.
- 2 The modulation of the burner output in accordance with the load required by the system, with maintenance of the pressure or temperature of the boiler at the operating values set.
- 3 The sequence (cascade adjustment) of more than one boiler through the suitable connection of the various units and the activation of the internal software of the individual systems (option).

Further interfaces and communication functions with computers, for remote control or integration in central supervision systems are available on the basis of the configuration of the system.



The first start up and every further internal setting operation of the adjustment system or the expansion of the base functions require access by means of password and are to be carried out by service personnel who are especially trained for the internal programming of the instrument and the specific application created with this burner.

5.4.3 Burner adjustment

The optimum adjustment of the burner requires an analysis of flue gases at the boiler outlet.

Adjust in sequence:

- 1 - Output upon ignition
- 2 - MAX output
- 3 - MIN output
- 4 - Intermediate outputs between Min. and Max.
- 5 - Air pressure switch
- 6 - Maximum gas pressure switch
- 7 - Minimum gas pressure switch

5.4.4 Output upon ignition



For safety purposes and correct product operation, the ignition output, if it is adjustable, must be carried out by authorized personnel and in compliance with the standards and regulations of the laws in force.

Air adjustment

The adjustment of the air is carried out by changing the angle of the air damper changing the degrees of the air servomotor inside the electronic cam programme.

5.4.5 Maximum output

The MAX output must be set within the firing rate (Fig. 5 on page 10).

Adjustment of gas delivery

Measure the gas delivery on the gas meter.

As an indicative guide it can be taken from Fig. 25, Fig. 26, Fig. 27 e Fig. 28 on page 29, just read the gas pressure on the pressure gauge (shown in Fig. 32 on page 33) and follow the instructions given on page 27.

- If it is necessary to reduce it, lower the output gas pressure via the pressure adjuster located beneath the gas valve.
- If delivery needs to be increased, increase the adjuster outlet gas pressure.

Air adjustment

If necessary vary the degrees of the air servomotor.

Indication for the burner ignition

In Tab. N the calibrations of the air and gas servomotors at the ignition point for each model are summarized according to the change of the maximum burnt power.

Ignition point - RS 68 ULX -

Maximum power input (kW)	1050	800	350
Gas motor/butterfly setting	8°	8°	10°
Air servomotor/damper setting	20°	18°	15°

Ignition point - RS 120 ULX -

Maximum power input (kW)	1450	1030	560
Gas motor/butterfly setting	6°	7°	10°
Air servomotor/damper setting	14°	14°	15°

Ignition point - RS 160 ULX -

Maximum power input (kW)	1950	1650	950
Gas motor/butterfly setting	1°	1°	10°
Air servomotor/damper setting	1°	1°	2°

Ignition point - RS 200 ULX -

Maximum power input (kW)	2400	1910	1350
Gas motor/butterfly setting	10°	10°	10°
Air servomotor/damper setting	3°	3°	2°

Tab. N

To determine the calibrations to use at the first start, proceed as follows:

- 1 Determine the maximum power required by the burner.
- 2 Open the combustion head as indicated in Fig. 21 on page 24.
- 3 Calculate the pressure required downstream of the gas train: this value is given by the sum of the boiler back pressure at the maximum burnt power and the pressure drop read on the diagrams of Fig. 25, Fig. 26, Fig. 27 and Fig. 28 on page 29.
- 4 Set the air and gas servomotors as suggested in Tab. N. If the maximum power falls between two indicated values, take an intermediate value between the two according to the opening degrees of the air and gas servomotors.



At the first ignition it is not recommended to use an air servomotor setting that exceeds the suggested setting by 10% .

5.4.6 Minimum output

The MIN output must be set within the firing rate (Fig. 5 on page 10).

5.5 Final calibration of the pressure switches

5.5.1 Air pressure switch

Adjust the air pressure switch (Fig. 34) after having performed all other burner adjustments with the air pressure switch set to the start of the scale.

With the burner working at MIN output, insert a combustion analyser in the stack, slowly close the suction inlet of the fan (for example, with a piece of cardboard) until the CO value does not exceed 100 ppm.

Slowly turn the appropriate knob clockwise until the burner goes into lockout.

Check the indication of the arrow pointing upwards on the graduated scale. Turn the knob clockwise again, until the value shown on the graduated scale corresponds with the arrow pointing downwards, and so recovering the hysteresis of the pressure switch (shown by the white mark on a blue background, between the two arrows).

Now check the correct start-up of the burner. If the burner locks out again, turn the knob slightly anticlockwise. During these operations it may be useful to measure the air pressure with a pressure gauge.

The connection of the pressure gauge is shown in Fig. 34. The standard configuration is that with the air pressure switch connected in absolute mode. Note the presence of a "T" connection, not supplied.

In certain applications in strong depression situations, the connection of the pressure switch does not allow it to change over. In this case it is necessary to connect the pressure switch in differential mode, applying a second tube between the air pressure switch and the fan suction line mouth.

In this case also, the pressure gauge must be connected in differential mode, as shown in Fig. 34.



Connecting the air pressure switch in differential mode, the burner will no longer be certified according to the EN 676 standard.

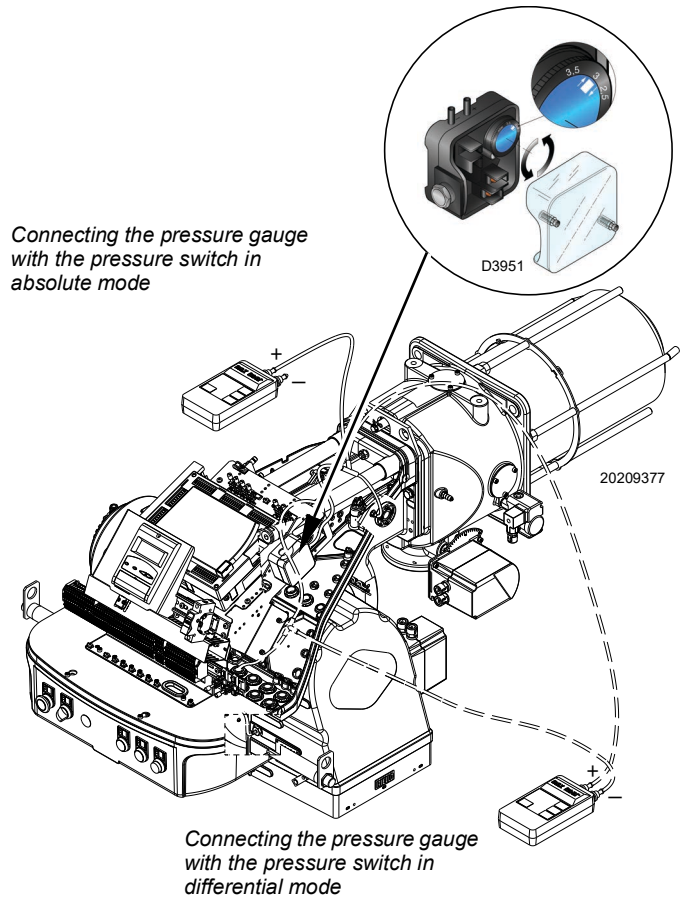

Fig. 34

5.5.2 Maximum gas pressure switch

Adjust the maximum gas pressure switch (Fig. 35) after making all other burner adjustments with the maximum gas pressure switch set to the end of the scale.

To calibrate the maximum gas pressure switch, open the tap and then connect a pressure gauge to its pressure test point.

The maximum gas pressure switch must be regulated to a value no higher than 30% of the measurement read on the gauge when the burner is working at maximum output.

After making the adjustment, remove the pressure gauge and close the tap.

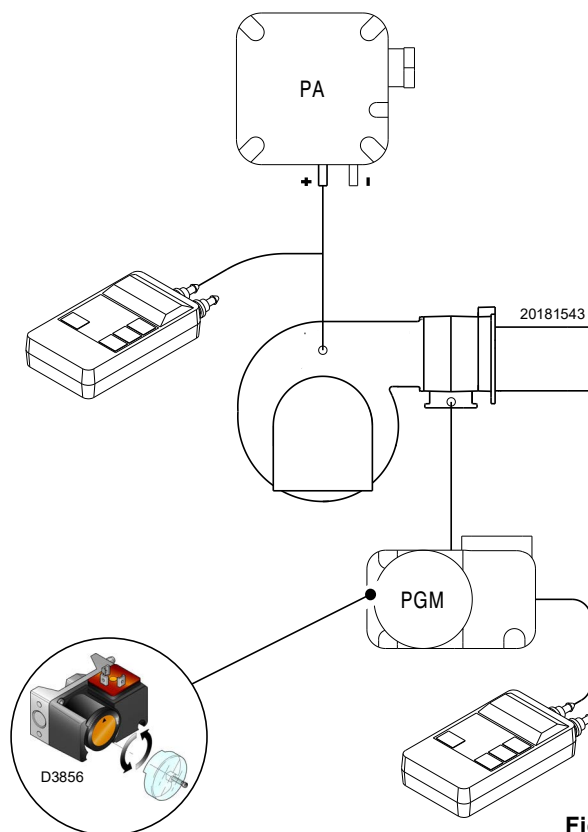

Fig. 35

5.5.3 Minimum gas pressure switch

Adjust the minimum gas pressure switch (Fig. 36) after having adjusted the burner, the gas valves and the gas train stabiliser. With the burner operating at maximum output:

- install a pressure gauge downstream of the gas train stabiliser (for example at the gas pressure test point on the burner combustion head);
- choke slowly the manual gas cock until the pressure gauge detects a decrease in the pressure read of about 0.1 kPa (1 mbar). In this phase, verify the CO value which must always be less than 100 mg/kWh (93 ppm).
- Increase the adjustment of the gas pressure switch until it intervenes, causing the burner shut-down;
- remove the pressure gauge and close the cock of the gas pressure test point used for the measurement;
- open completely the manual gas cock.



1 kPa = 10 mbar

WARNING

5.5.4 PVP pressure switch kit

Adjust the pressure switch for the valve leak detection control device (PVP Kit) (Fig. 37), if present, according to the instructions supplied with the Kit itself.

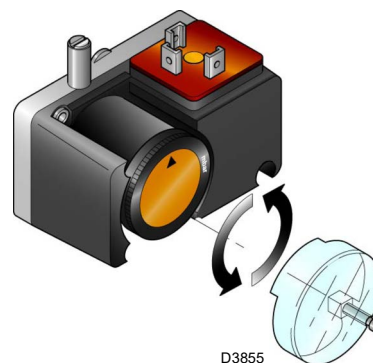

Fig. 36

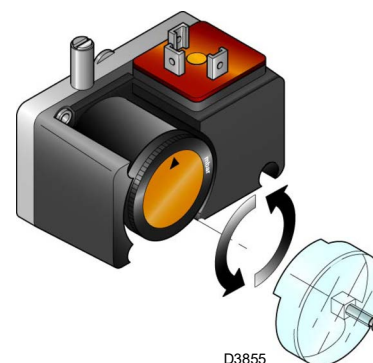

Fig. 37

5.6 Operation

Once the start-up cycle is completed, the servomotor command moves on to the thermostat/pressure switch TR that controls the pressure or the temperature in the boiler.

- If the temperature or the pressure is low, the burner progressively increases the output as far as the MAX value.
- If the temperature or the pressure increases, the burner progressively reduces the output as far as the MIN value. The sequence repeats endlessly.

- The burner stops when the heat request is less than the heat supplied by the burner at MIN output.
- The thermostat/pressure switch TL opens, the flame control carries out the switching off phase.
- The air damper closes completely to reduce heat losses to a minimum.

5.7 Ignition failure

If the burner does not switch on, there is a lockout within 3s of the electrical supply reaching the gas valve.

It may be that the gas does not arrive at the combustion head within the safety time of 3s.

In this case increase gas ignition flow rate. The arrival of gas to the pipe coupling is displayed on the pressure gauge, as shown in (Fig. 39 on page 41).



In the event the burner stops, in order to prevent any damage to the installation, do not unblock the burner more than twice in a row.

If the burner locks out for a third time, contact the customer service.



In the event there are further lockouts or faults with the burner, the maintenance interventions must only be carried out by qualified, authorised personnel, in accordance with the contents of this manual and in compliance with the standards and regulations of current laws.

5.8 Burner flame goes out during operation

If the flame should go out during operation, the burner will lockout within 1 s.

5.9 Stopping of the burner

The burner can be stopped by:

- intervening on the disconnecting switch of the electrical supply line, located on the boiler panel;
- using the switch “0-AUTO” of Fig. 33 on page 34.

5.10 Final checks (with burner operating)

<ul style="list-style-type: none"> ➤ Open the thermostat/pressure switch TL ➤ Open the thermostat/pressure switch TS 		The burner must stop
<ul style="list-style-type: none"> ➤ Turn the gas maximum pressure switch knob to the minimum end of scale position ➤ Turn the air pressure switch knob to the maximum end of scale position 		The burner must stop in lockout
<ul style="list-style-type: none"> ➤ Turn off the burner and cut off the power ➤ Disconnect the minimum gas pressure switch connector 		The burner must not start
<ul style="list-style-type: none"> ➤ Disconnect the connector of the ionisation probe 		The burner must stop in lockout due to ignition failure

Tab. O



Make sure that the mechanical locking systems on the various adjustment devices are fully tightened.

5.11 Description of O₂ trim control (optional)

A special feature of the LMV52... is control of the residual O₂ content to increase the boiler's efficiency. The LMV52... uses a QGO20..., an external PLL52..., and the standard components of the LMV51... The PLL52... is a detached measuring module for the O₂ sensor and for 2 temperature sensors (Pt1000 / LG-Ni1000). The module communicates with the LMV52... via CAN bus.

The following generic diagram shows the system (Fig. 38).

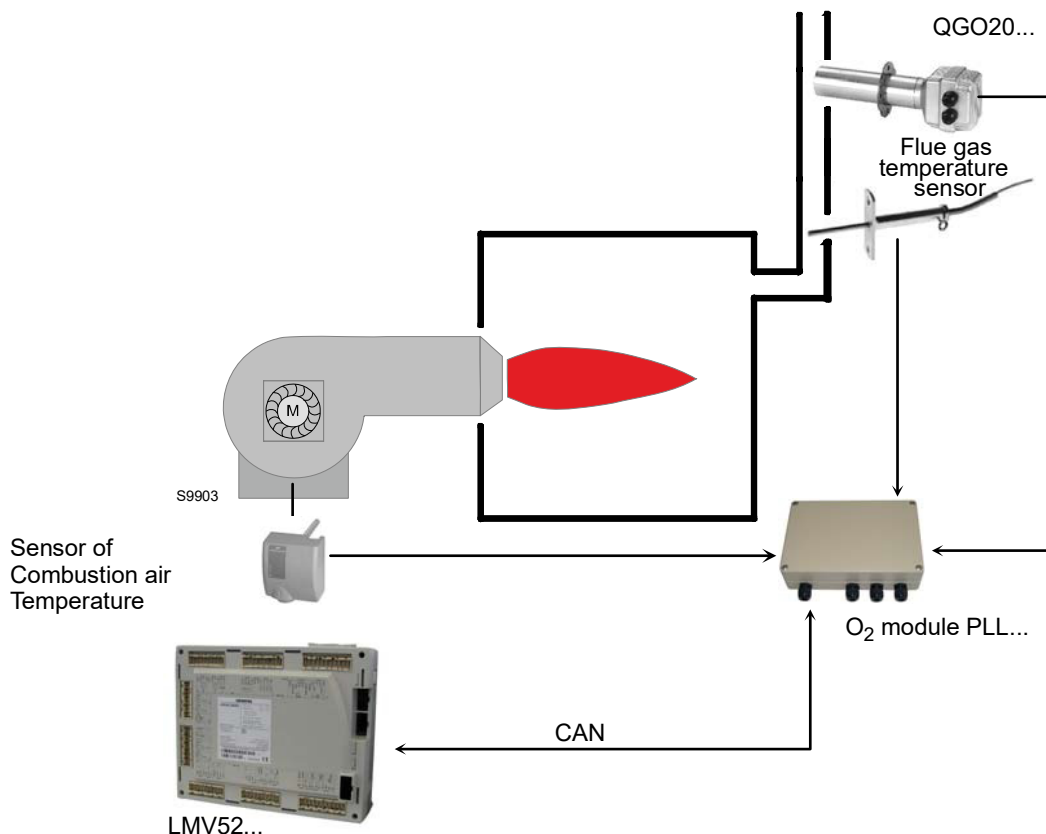

Fig. 38

5.11.1 Operating principle of O₂ trim control

The residual O₂ control system reduces the amount of combustion air depending on the control deviation (O₂ setpoint minus actual of O₂). The amount of combustion air is normally influenced by several actuators and, if used, by a VSD. **Reduction of the amount of air is reached by reducing the «air rate» of the air-regulating actuators.**

For that purpose, the damper positions of these actuators are calculated from some other load point on the ratio control curves. Hence, due to the parameterized ratio control curves, the air-regulating actuators are in a fixed relation to one another.

O₂ trim control is supported by **precontrol**. It calculates the air rate reduction such that changes in burner load do not require the O₂ trim controller to interfere. Consideration is given to a number of measured values that are ascertained when the burner is set. This means that the controller only becomes active when environmental conditions (temperature, pressure) change, and not when the burner load changes.



The installation and setting of the system must be carried out by qualified personnel, as indicated in the specific documentation of the device.

6 Maintenance

6.1 Notes on safety for the maintenance

The periodic maintenance is essential for the good operation, safety, yield and duration of the burner.

It allows you to reduce consumption and polluting emissions and to keep the product in a reliable state over time.



The maintenance interventions and the calibration of the burner must only be carried out by qualified, authorised personnel, in accordance with the contents of this manual and in compliance with the standards and regulations of current laws.

Before carrying out any maintenance, cleaning or checking operations:



Disconnect the electrical supply from the burner by means of the main system switch.



Close the fuel interception tap.



Wait for the components in contact with heat sources to cool down completely.

6.2 Maintenance programme

6.2.1 Maintenance frequency



The gas combustion system should be checked at least once a year by a representative of the manufacturer or another specialised technician.

6.2.2 Safety test - with gas feeding closed

For its safe commissioning it is very important to make sure that the electrical wiring has been carried out correctly between the gas valves and the burner.

To this end, after checking that the connections have been made in conformity with the burner's wiring diagram, a starting cycle should be carried out with the gas tap closed (dry test).

- 1 The manual gas valve should be closed with the locking/releasing device ("lock-out / tag out" procedure).
- 2 Make sure the limit electric contacts of the burner close
- 3 Make sure the contact of the minimum gas pressure switch closes
- 4 Proceed with a tentative start up of the burner.

The starting cycle should occur with the following phases:

- Starting the fan motor for pre-purging
- Carrying out the gas valve leak detection control, if applicable
- Completing the pre-purging
- Reaching the ignition point
- Power supply of the ignition transformer
- Power supply the gas valves.

Since the gas is closed, the burner will not be able to start and its flame control will stop or go into a safety lockout.

The effective supplying of the gas valves can be checked with the insertion of a tester; some valves are fitted with light signals (or closure/opening position indicators) that are activated when the electrical supply arrives.



IF THE ELECTRICAL SUPPLY OF THE GAS VALVES OCCURS AT AN UNEXPECTED MOMENT, DO NOT OPEN THE MANUAL VALVE, DISCONNECT THE ELECTRICAL SUPPLY, CHECK THE WIRING; CORRECT THE ERRORS AND CARRY OUT THE ENTIRE TEST AGAIN.

6.2.3 Checking and cleaning



The operator must use the required equipment during maintenance.

Combustion

The optimum calibration of the burner requires an analysis of the flue gases. Significant differences with respect to the previous measurements indicate the points where more care should be exercised during maintenance.

Combustion head

Open the burner and make sure that all the components of the combustion head are undamaged, not deformed due to high temperature, free of ambient dirt or dust, free of rusted materials and adequately positioned.

Make sure that the gas outlet holes for the start-up, on the combustion head distributor, are free of dirt or rust deposits. In if doubt, disassemble the elbow.

Fan

Check to make sure that no dust has accumulated inside the fan or on its blades, as this condition will cause a reduction in the air flow rate and provoke polluting combustion.

Burner

Clean the outside of the burner.

Gas leaks

Make sure that there are no gas leaks on the pipes between the gas meter and the burner.

Gas filter

Replace the gas filter when it is dirty.

Flame inspection window

Clean the glass of the flame inspection window.

Boiler

Clean the boiler as indicated in its accompanying instructions in order to maintain all the original combustion characteristics intact, especially the flue gas temperature and combustion chamber pressure.

Electric current to the flame sensor

Clean the ionization probe from any dust.
Check the mechanical integrity of the component and the flame signal measured by the flame control.

Combustion

If the combustion values found at the start of the intervention do not satisfy current standards or anyway indicate a poor state of combustion (consult the table below), contact the Technical Assistance Service for the necessary adjustments.

EN 676		Air excess			
		Max. output $\lambda \leq 1.2$		Min. output $\lambda \leq 1.3$	
GAS	CO ₂ theoretic al max. 0% O ₂	CO ₂ % Calibration		CO	NO _x
		$\lambda = 1.2$	$\lambda = 1.3$	mg/kWh	mg/kWh
G 20	11.7	9.7	9.0	≤ 100	≤ 170
G 25	11.5	9.5	8.8	≤ 100	≤ 170

Tab. P

6.2.4 Safety components

The safety components should be replaced at the end of their life cycle indicated in Tab. Q.

The specified life cycles do not refer to the warranty terms indicated in the delivery or payment conditions.

Safety component	Life cycle
Flame control	10 years or 250,000 operation cycles
Gas valves (solenoid)	10 years or 250,000 operation cycles
Pressure switches	10 years or 250,000 operation cycles
Pressure adjuster	15 years
Servomotor (electronic cam) (if present)	10 years or 250,000 operation cycles
Oil valve (solenoid) (if present)	10 years or 250,000 operation cycles
Oil regulator (if present)	10 years or 250,000 operation cycles
Oil pipes/ couplings (metallic) (if present)	10 years
Fan impeller	10 years or 500,000 start-ups

Tab. Q

6.2.5 Checking the air and gas pressure on the combustion head

To carry out this operation a pressure gauge must be used to measure the air and gas pressure at the combustion head, as shown in Fig. 39 and Fig. 40.

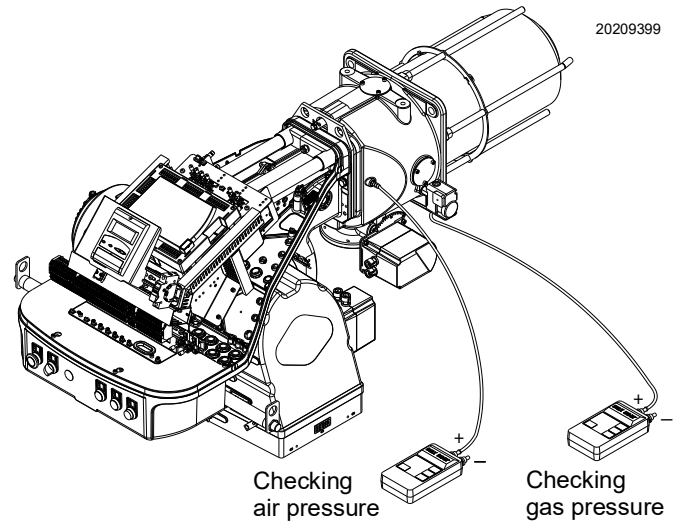

Fig. 39

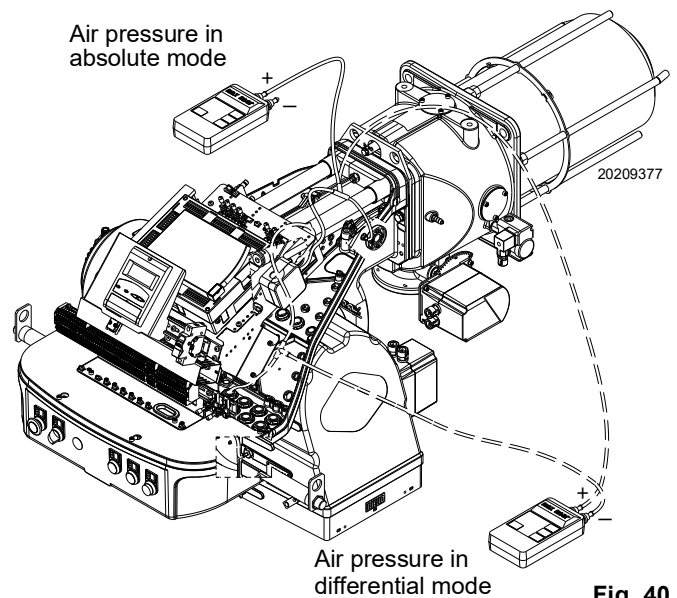

Fig. 40

6.3 Opening the burner



Disconnect the electrical supply from the burner by means of the main system switch.



Turn off the fuel interception tap.



Wait for the components in contact with heat sources to cool down completely.

- Loosen the 4 screws 1)(Fig. 41) and remove the cover 2);
- assemble the two extensions supplied on the slide bars 4) and tighten the screws 7);
- disconnect the connector of the gas servomotor;
- disconnect the socket from the maximum gas pressure switch;
- remove the screws 3) and move the burner backwards by about 100 mm on the slide bars 4);
- disconnect the probe and electrode leads and then pull the burner fully back.

At this point it is possible to extract the inner part 5) after having removed the screw 6).

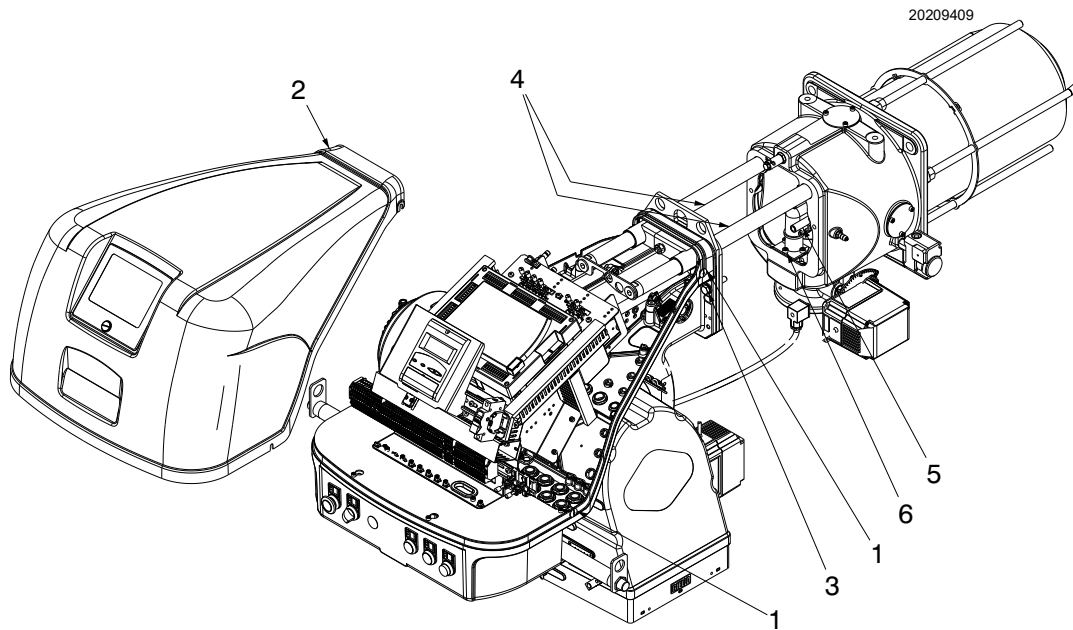

Fig. 41

6.4 Closing the burner

- Push the burner up to approximately 100 mm from the pipe coupling;
- reconnect the cables and slide in the burner until it comes to a stop;
- connect the servomotor connector;
- connect the socket of the maximum gas pressure switch;
- replace the screws 3) and carefully pull the probe and electrode cables outwards until they are slightly taut;
- disassemble the two extensions from the guides 4).



After carrying out maintenance, cleaning or checking operations, reassemble the hood and all the safety and protection devices of the burner.

A Appendix - Accessories**Soundproofing chamber kit**

Burner	Type	dB(A)	Code
All models	C4/5	10	3010404

Inverter kit (variable speed drive)

Burner	Max. output (kW)	Code
RS 68/EV O2 ULX	1.5	20163060
RS 120/EV O2 ULX	3.0	20163064
RS 160-200/EV O2 ULX	5.5	20163071

Software interface kit (ACS 450)

Burner	Code
All models	3010388

Continuous purging kit

Burner	Code
All models	3010437

PVP kit (Pressure Valve Proving)

Burner	Code
All models	3010344

Efficiency kit with oxygen control kit

Burner	Code
All models	3010377

Oxygen control kit

Burner	Code
All models	20045187

Additional transformer kit

Burner	Code
All models	20044177

Gas trains in compliance with EN 676

Please refer to manual.



ATTENZIONE

The installer is responsible for the addition of any safety device not foreseen in this manual.

B Appendix - Electrical panel layout

1	Index of layouts
2	Reference indication
3	Layout of unifilar output
4	LMV 52 ... operational layout
5	LMV 52 ... operational layout
6	LMV 52 ... operational layout
7	LMV 52 ... operational layout
8	LMV 52 ... operational layout
9	LMV 52 ... operational layout
10	LMV 52 ... operational layout
11	Electrical wiring that is the responsibility of the installer
11B	Electrical wiring that is the responsibility of the installer
12	Electrical wiring that is the responsibility of the installer
13	Electrical wiring that is the responsibility of the installer
14	Electrical wiring that is the responsibility of the installer

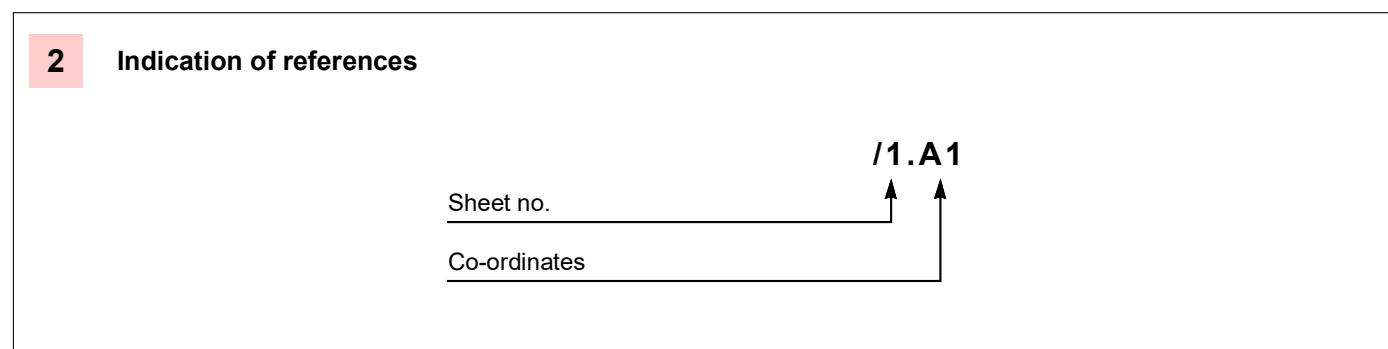

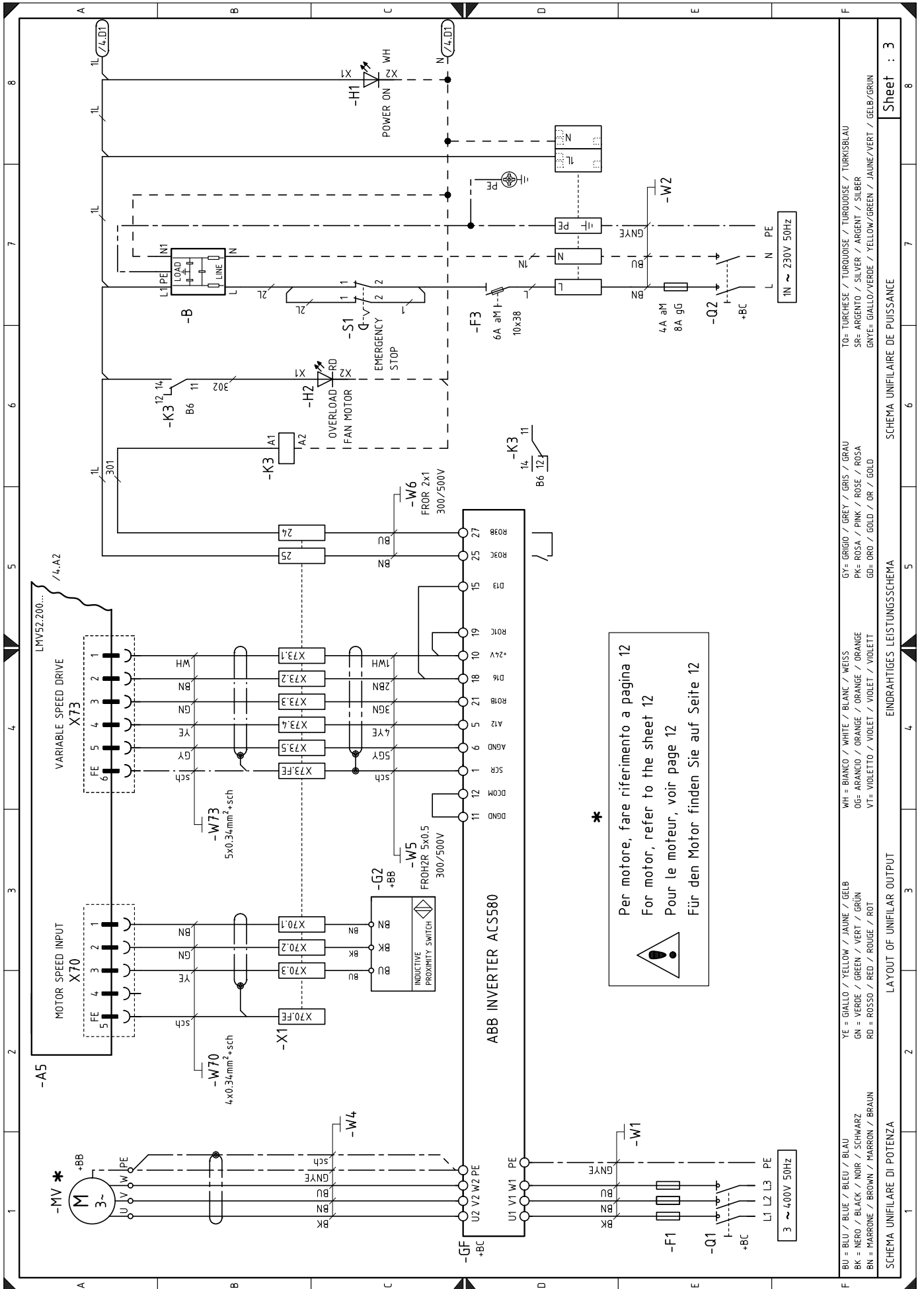

BU = BLU / BLUE / BLAU	YE = GIALLO / YELLOW / JAUNE / GELB	WH = BIANCO / WHITE / BLANK / WEISS	GY = GRIGIO / GREY / GRIS / GRAU	TO = TURCHESE / TURQUOISE / TURKISBLAU
BK = NERO / BLACK / NOIR / SCHWARZ	GN = VERDE / GREEN / VERT / GRÜN	OG = ARANCIO / ORANGE / ORANGE / ORANGE	PK = ROSA / PINK / ROSE / ROSA	SR = ARGENTO / SILVER / ARGENT / SILBER
BN = MARRONE / BROWN / MARRON / BRAUN	RD = ROSSO / RED / ROUGE / ROT	VI = VIOLETTA / VIOLET / VIOLET / VIOLETT	GD = ORO / GOLD / OR / GOLD	GNVE = GIALLO/VERDE / YELLOW/GREEN / JAUNE/VERT / GELB/GRÜN

SCHEMA UNIFILARE DI POTENZA LAYOUT OF UNIFILAR OUTPUT EINDRAHTIGES LEISTUNGSSCHEMA SCHEMA UNIFILARE DE PUISSANCE

Sheet : 3

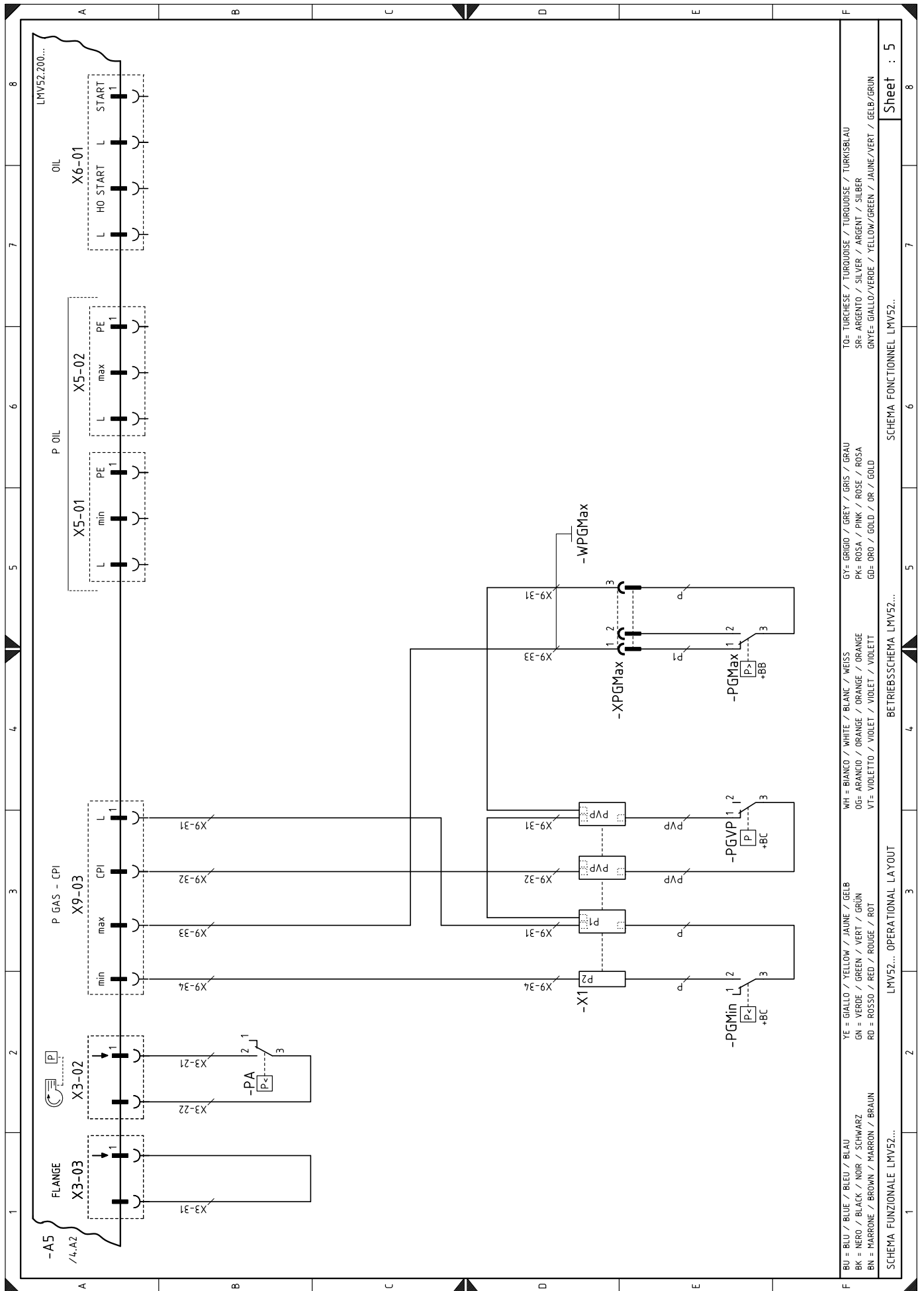

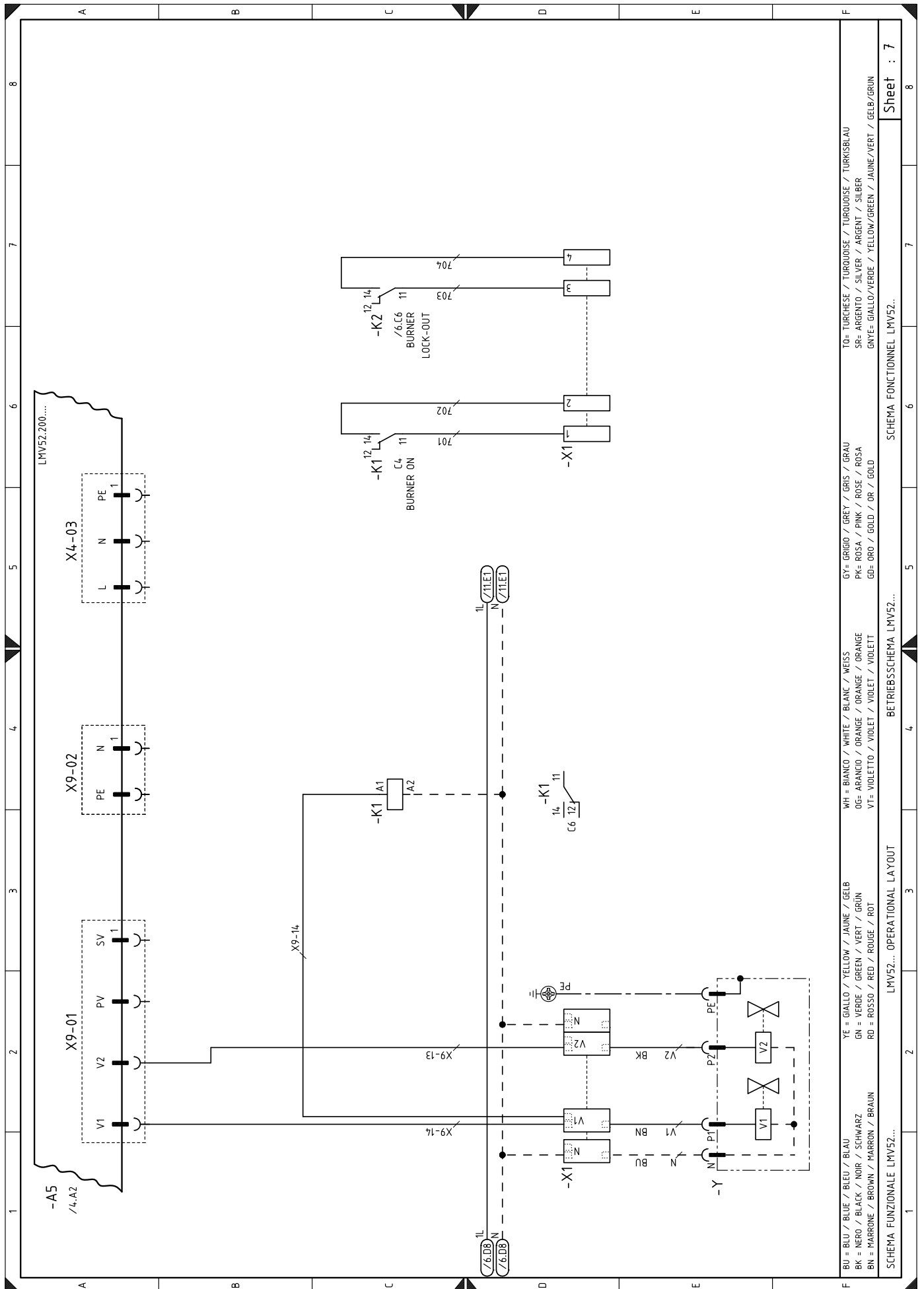

BU = BLU / BLUE / BLEU / BLAU	WH = BIANCO / WHITE / BLANC / WEISS	GY = GRIGIO / GREY / GRIS / GRAU	TO = TURCHESE / TURQUOISE / TURKOISE / TURKISBLAU
BK = NERO / BLACK / NOIR / SCHWARZ	OG = ARANCIO / ORANGE / ORANGE / ORANGE	PK = ROSA / PINK / ROSE / ROSA	SR = ARGENTO / SILVER / ARGENT / SILBER
BN = MARRONE / BROWN / MARRON / BRAUN	VI = VIOLETTA / VIOLET / VIOLET / VIOLETT	GD = ORO / GOLD / OR / GOLD	GN = GIALLO/VERDE / YELLOW/GREEN / JAUNE/VERT / GELB/GRÜN
YE = GIALLO / YELLOW / JAUNE / GELB			
GN = VERDE / GREEN / VERT / GRÜN			
RD = ROSSO / RED / ROUGE / ROT			

Sheet : 7

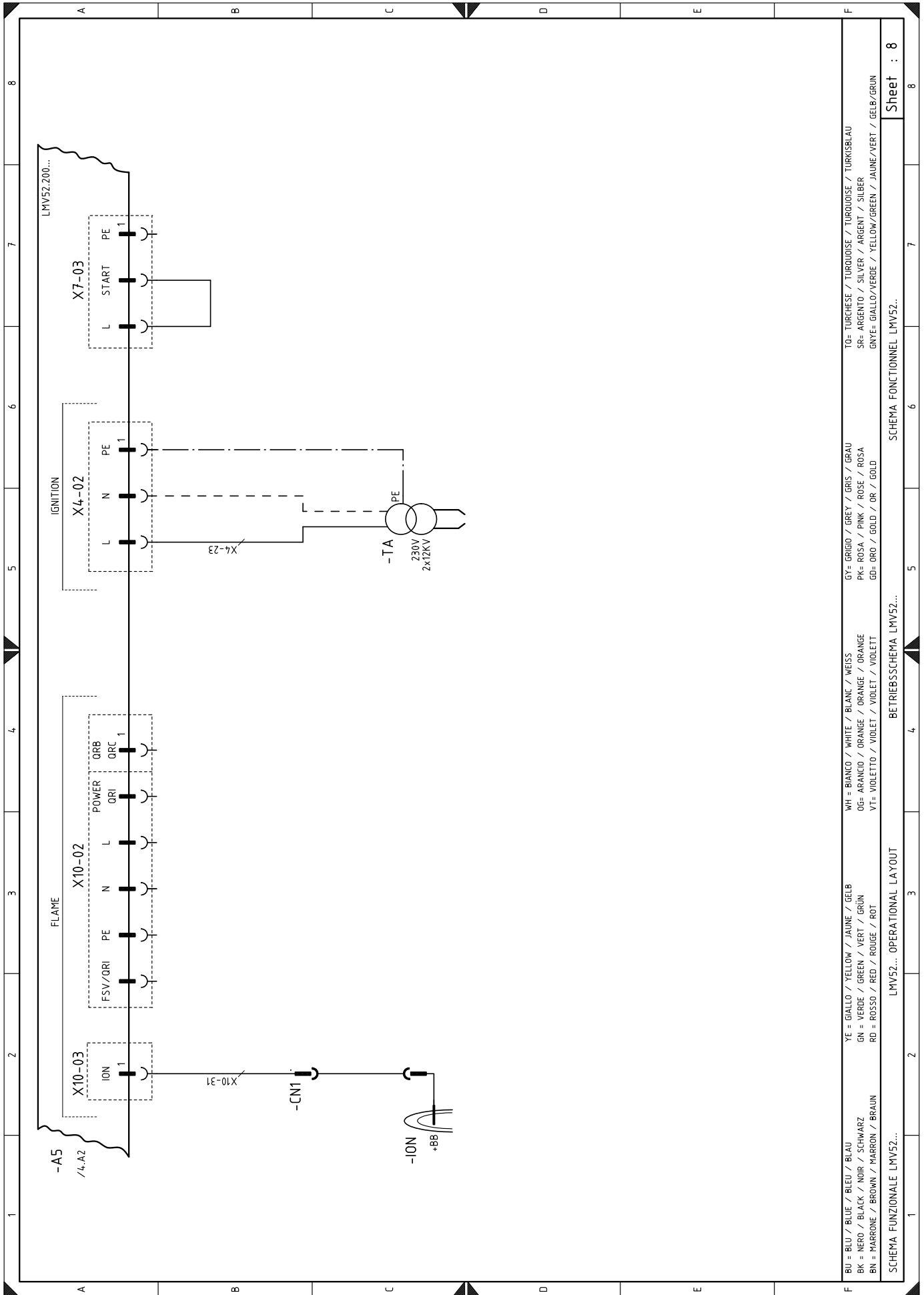

BU = BLU / BLUE / BLEU / BLAU	YE = GIALLO / YELLOW / JAUNE / GELB	WH = BIANCO / WHITE / BLANC / WEISS	GY= GRIGIO / GREY / GRIS / GRAU	TO= TURCHESE / TURQUOISE / TURKUISE / TURKISBLAU
BK = NERO / BLACK / NOIR / SCHWARZ	GN = VERDE / GREEN / VERT / GRÜN	OG= ARANCIO / ORANGE / ORANGE / ORANGE	PK= ROSA / PINK / ROSE / ROSA	SR= ARGENTO / SILVER / ARGENT / SILBER
BN = MARRONE / BROWN / MARRON / BRAUN	RD = ROSSO / RED / ROUGE / ROT	VT= VIOLETTA / VIOLET / VIOLET / VIOLETT	GD= ORO / GOLD / OR / GOLD	GYE= GIALLO/VERDE / YELLOW/GREEN / JAUNE/VERT / GELB/GRÜN
SCHEMA FUNZIONALE LMV52...				
LMV52... OPERATIONAL LAYOUT		BETRIEBSSCHEMA LMV52...		
SCHEMA FONCTIONNEL LMV52...				

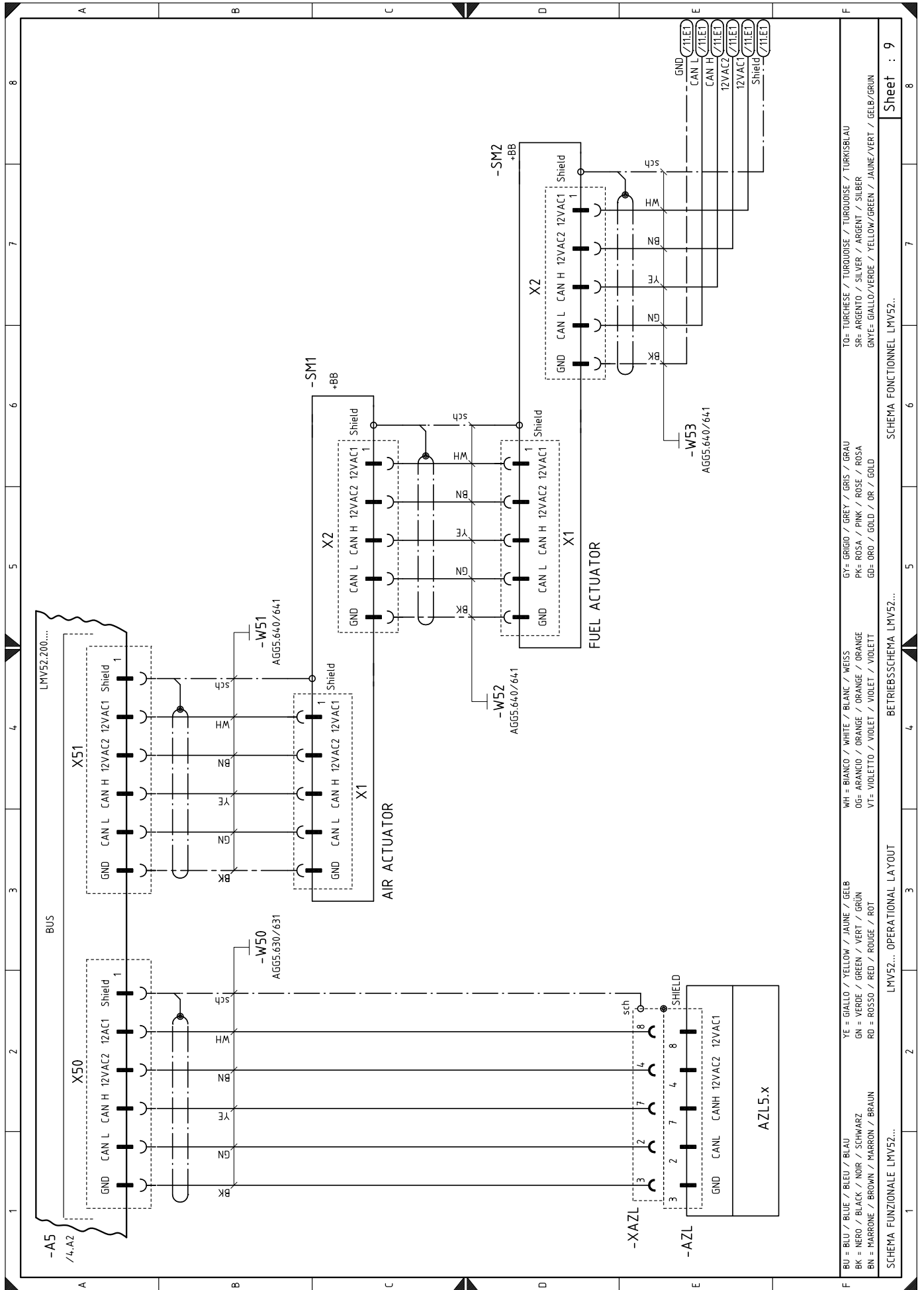

BU = BLU / BLUE / BLEU / BLAU
 BK = NERO / BLACK / NOIR / SCHWARZ
 BN = MARRONE / BROWN / MARRON / BRAUN
 YE = GIALLO / YELLOW / JAUNE / GELB
 GN = VERDE / GREEN / VERT / GRÜN
 RD = ROSSO / RED / ROUGE / ROT
 WH = BIANCO / WHITE / BLANC / WEISS
 DG = ARANCIO / ORANGE / ORANGE / ORANGE
 VT = VIOLETTA / VIOLET / VIOLET / VIOLETT
 GY = GRIGIO / GREY / GRIS / GRAU
 PK = ROSA / PINK / ROSE / ROSA
 GB = ORO / GOLD / OR / GOLD
 TO = TURCHESE / TURQUOISE / TURQUOISE / TURKISBLAU
 SR = ARGENTO / SILVER / ARGENT / SILBER
 GNYE = GIALLO/VERDE / YELLOW/GREEN / JAUNE/VERT / GELB/GRÜN

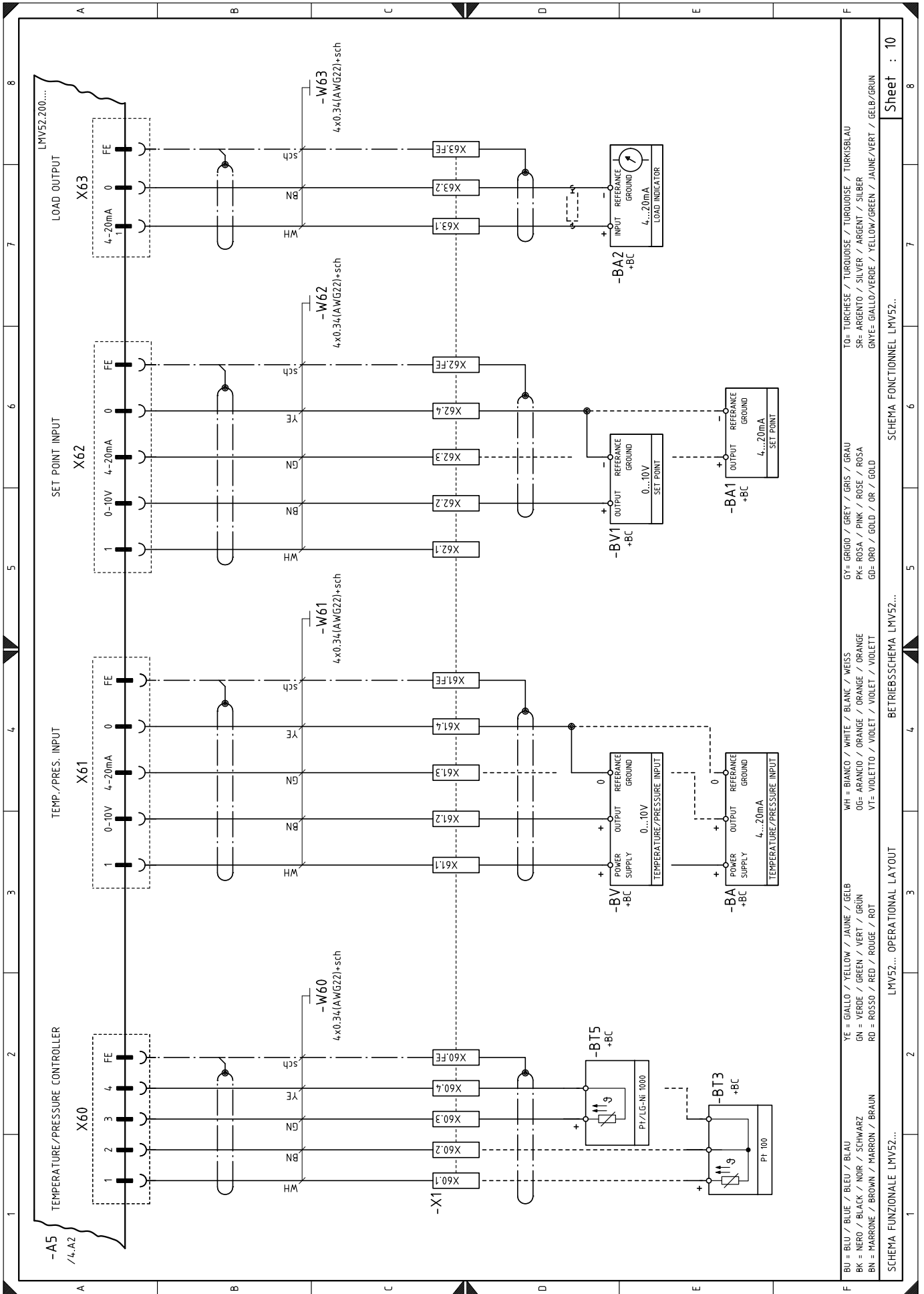

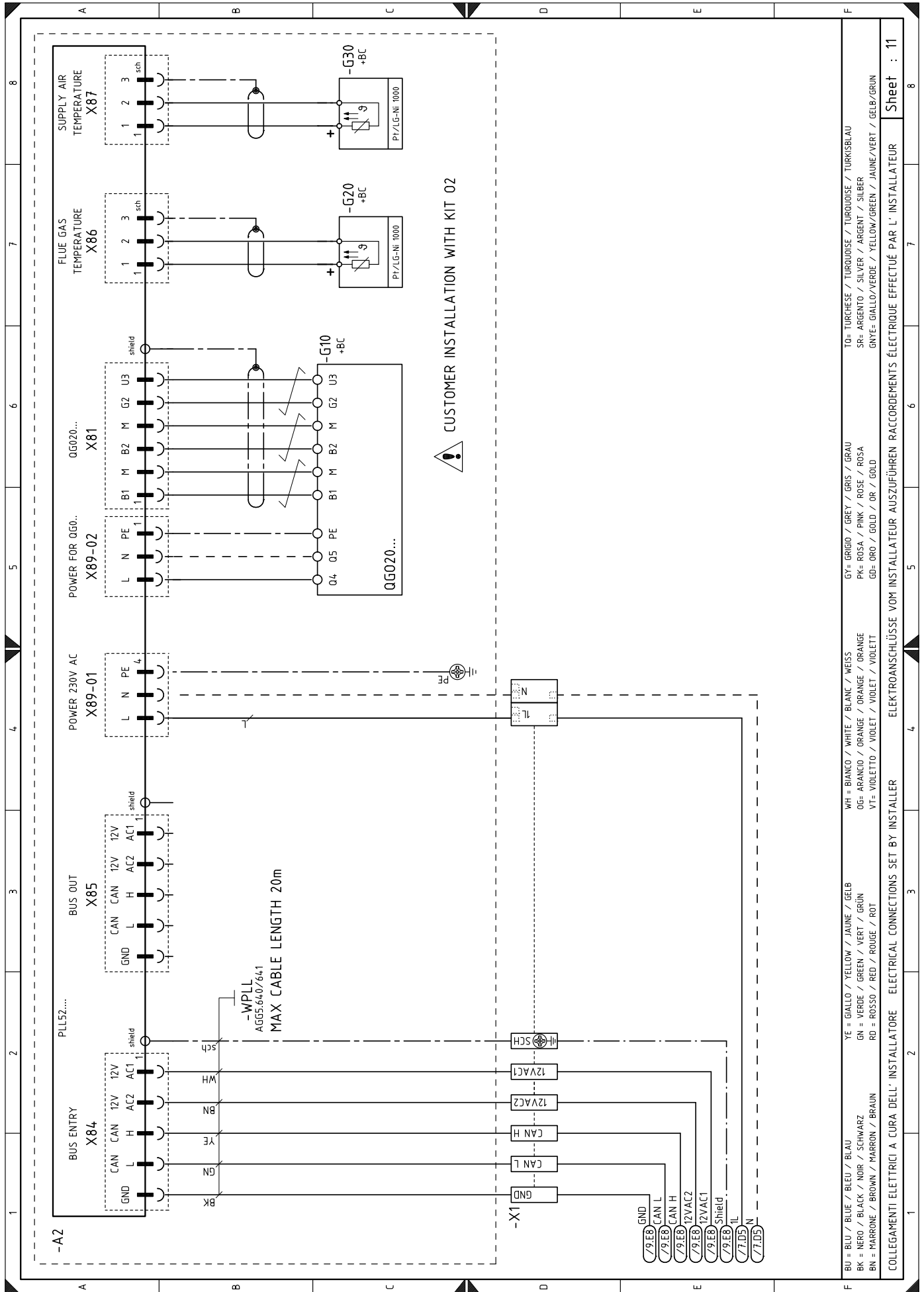

BU = BLU / BLUE / BLEU / BLAU	YE = GIALLO / YELLOW / JAUNE / GELB	WH = BIANCO / WHITE / BLANC / WEISS	GY = GRIGIO / GREY / GRIS / GRAU	TO= TURCHESE / TURQUOISE / TURKUISE / TURKISBLAU
BK = NERO / BLACK / NOIR / SCHWARZ	GN = VERDE / GREEN / VERT / GRÜN	OG= ARANCIO / ORANGE / ORANGE / ORANGE	PK= ROSA / PINK / ROSE / ROSA	SR= ARGENTO / SILVER / ARGENT / SILBER
BN = MARRONE / BROWN / MARRON / BRAUN	RD = ROSSO / RED / ROUGE / ROT	VI= VIOLETT / VIOLET / VIOLET / VIOLETT	GD= ORO / GOLD / OR / GOLD	GNTE= GIALLO/VERDE / YELLOW/GREEN / JAUNE/VERT / GELB/GRÜN

COLLEGAMENTI ELETTRICI A CURA DELL'INSTALLATORE ELECTRICAL CONNECTIONS SET BY INSTALLER ELEKTROANSCHLÜSSE VOM INSTALLATEUR AUSZUFÜHREN RACCORDI ELETTRICI EFFETTUÉ PAR L'INSTALLATEUR

Sheet : 11

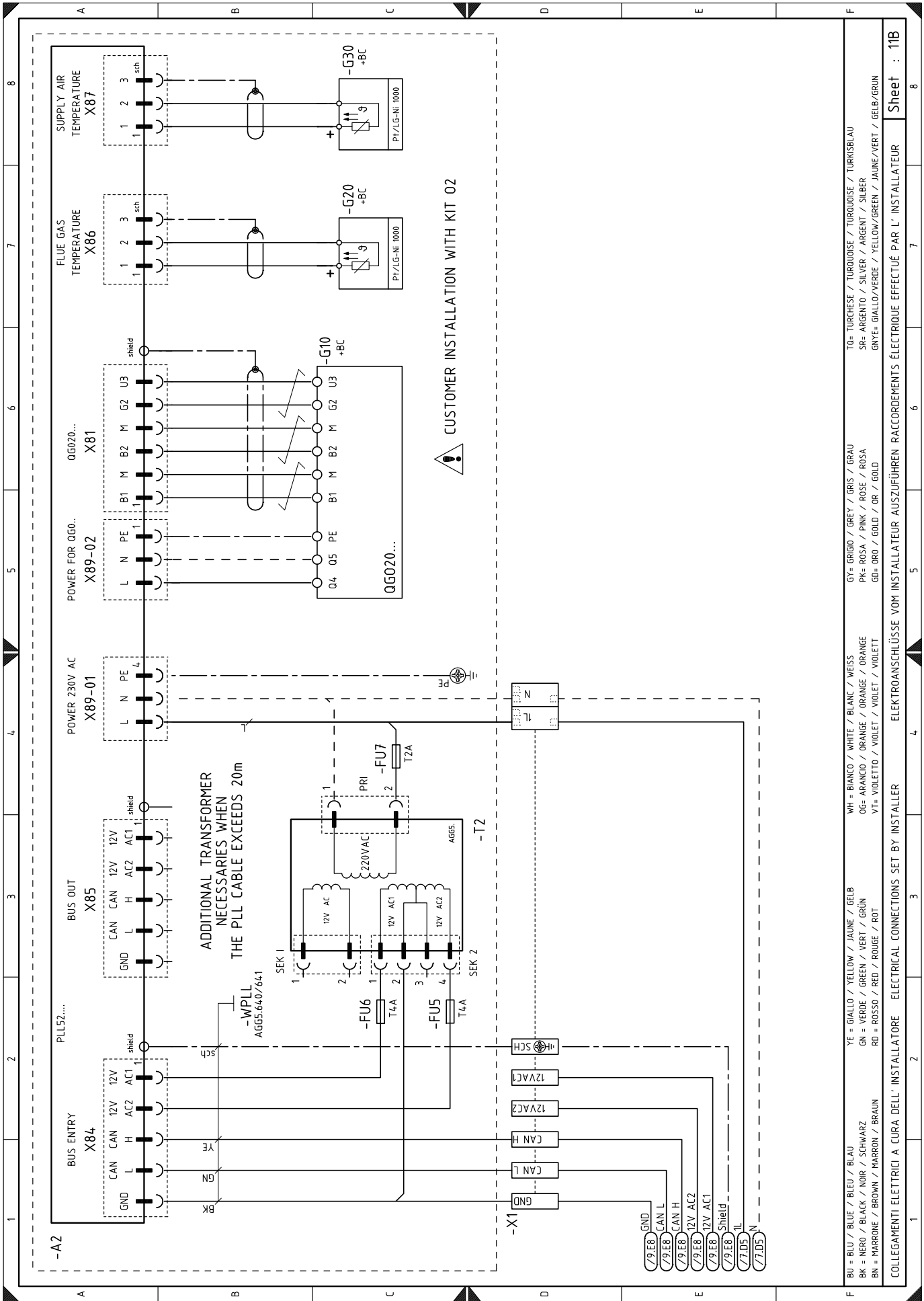

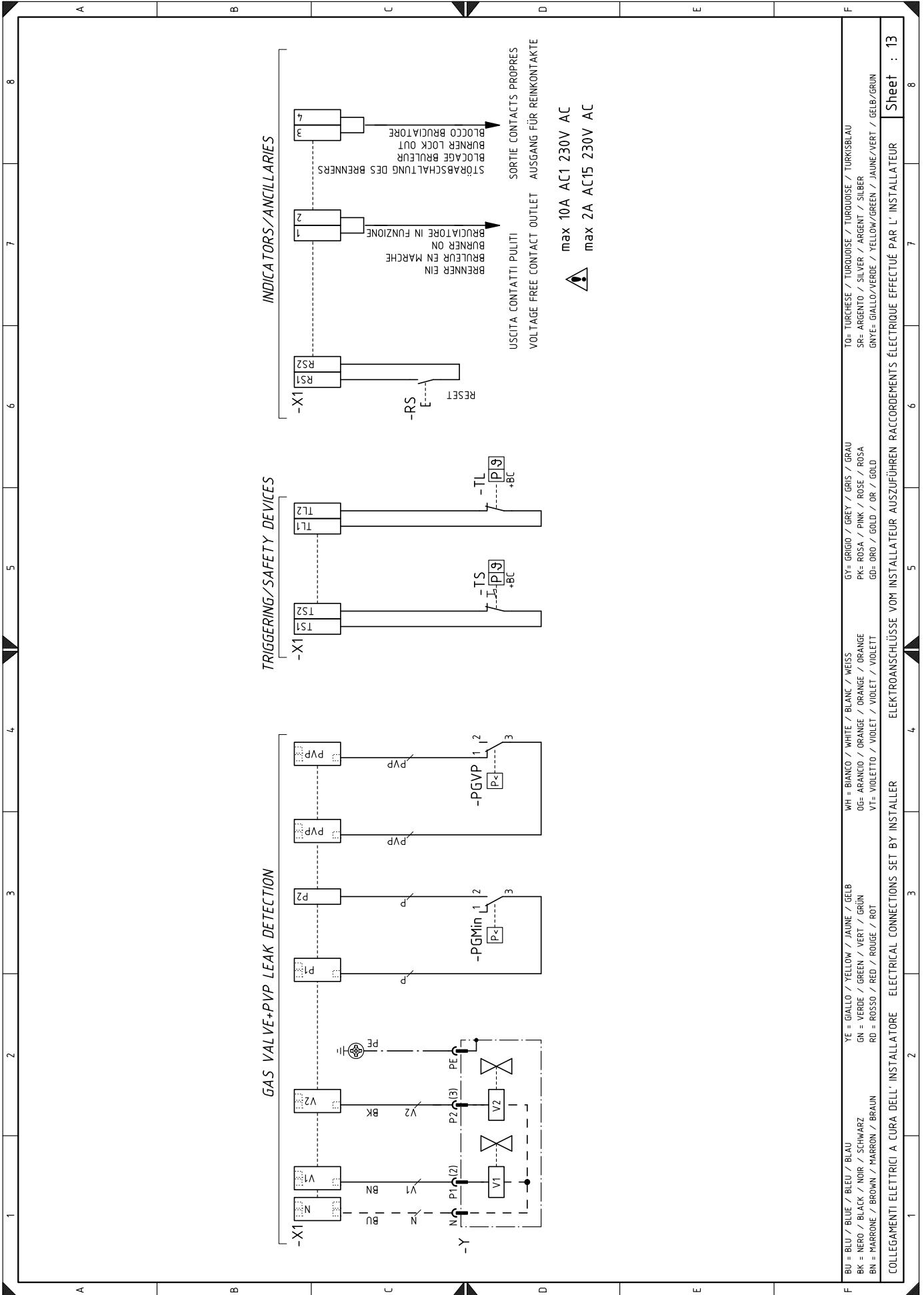

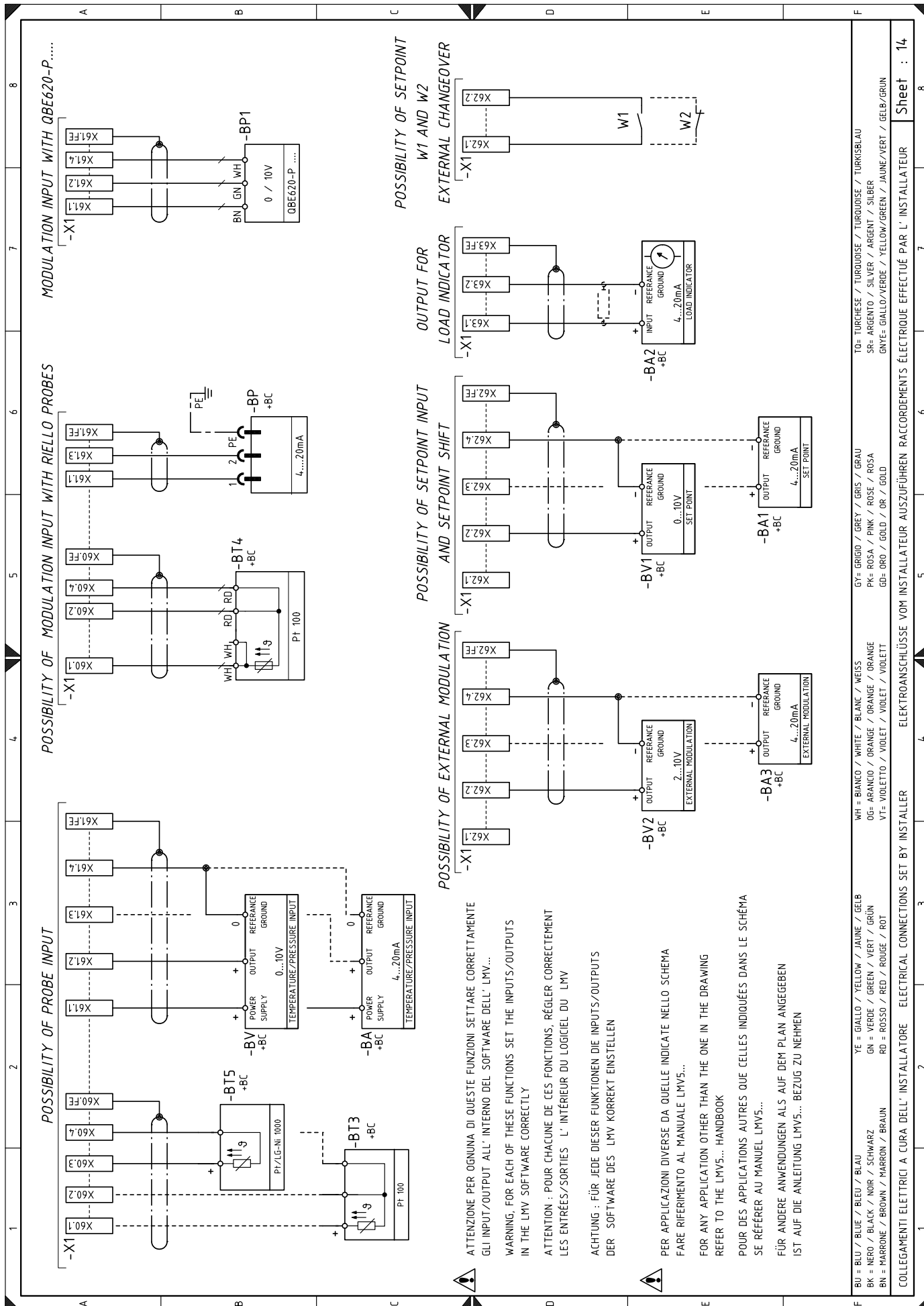

POSSIBILITY OF PROBE INPUT

POSSIBILITY OF MODULATION INPUT WITH RIELLO PROBES

MODULATION INPUT WITH QBEG620-P.....

POSSIBILITY OF SETPOINT W1 AND W2 EXTERNAL CHANGEOVER

OUTPUT FOR LOAD INDICATOR

POSSIBILITY OF SETPOINT INPUT AND SETPOINT SHIFT

POSSIBILITY OF EXTERNAL MODULATION

ATTENZIONE PER OGNIUNA DI QUESTE FUNZIONI SETTARE CORRETTAMENTE GLI INPUT/OUTPUT ALL' INTERNO DEL SOFTWARE DELL' LMV...
WARNING, FOR EACH OF THESE FUNCTIONS SET THE INPUTS/OUTPUTS IN THE LMV SOFTWARE CORRECTLY

ATTENTION : POUR CHACUNE DE CES FONCTIONS, RÉGLER CORRECTEMENT LES ENTRÉES/SORTIES L' INTÉRIEUR DU LOGICIEL DU LMV

ACHTUNG : FÜR JEDE DIESER FUNKTIONEN DIE INPUTS/OUTPUTS DER SOFTWARE DES LMV KORREKT EINSTELLEN

PER APPLICAZIONI DIVERSE DA QUELLE INDICATE NELLO SCHEMA FARE RIFERIMENTO AL MANUALE LMV5...

FOR ANY APPLICATION OTHER THAN THE ONE IN THE DRAWING REFER TO THE LMV5... HANDBOOK

POUR DES APPLICATIONS AUTRES QUE CELLES INDICÉES DANS LE SCHÉMA SE RÉFÉRER AU MANUEL LMV5...

FÜR ANDERE ANWENDUNGEN ALS AUF DEM PLAN ANGEGEBEN IST AUF DIE ANLEITUNG LMV5... BEZUG ZU NEHMEN

BU = BLU / BLUE / BLEU / BLAU	YE = GIALLO / YELLOW / JAUNE / GELB	GY = GRIGIO / GREY / GRIS / GRAU	TO = TURCHESE / TURQUOISE / TURKISBLAU
BR = NERO / BLACK / NOIR / SCHWARZ	GN = VERDE / GREEN / VERT / GRÜN	PK = ROSA / PINK / ROSE / ROSA	SR = ARGENTO / SILVER / ARGENT / SILBER
BN = MARRONE / BROWN / MARRON / BRAUN	RD = ROSSO / RED / ROUGE / ROT	GB = ORO / GOLD / OR / GOLD	GNYE = GIALLO/VERDE / YELLOW/GREEN / JAUNE/VERT / GELB/GRÜN
VT = VIOLETT / VIOLET / VIOLET / VIOLETT			

Wiring layout key

A1	Flame control
A2	O2 module PLL.. type
AZL	Display and calibration unit
BA	Output probe in current
BA1	Device with output undercurrent, for modifying remote setpoint
BA2	Load indicator
BA3	Input in current DC 4...20 mA
BP	Pressure probe
BP1	Pressure probe
BT3	Probe Pt100, 3 wires
BT4	Probe Pt100, 3 wires
BT5	PT/LG-Ni1000 probe
BV	Output probe in voltage
BV1	Output device in voltage to modify remote setpoint
CN1	Ionisation probe connector
FU	Auxiliary circuits safety fuse
GF	Inverter
G2	Rpm sensor
G10	O2 sensor OGO20 type
G20	Combustion fume temperature sensor probe
G30	Air temperature control probe
H	Burner working lighting signal output
H1	Light signalling of mains live state
H2	Fan motor lock-out warning lamp
ION	Ionisation probe
K1	Clean contacts output relay burner switched on
K2	Clean contacts output relay burner lockout
K3	Clean contacts output relay VSD alarm
MV	Fan motor
PA	Air pressure switch
PE	Burner earth
PGMax	Maximum gas pressure switch
PGMin	Minimum gas pressure switch
PGVP	Gas pressure switch for valve leak detection control device
QRI	Infrared sensor
RS	Burner reset switch
SM1	Air servomotor
SM2	Gas servomotor
S1	Emergency stop button
S2	Automatic / off selector
SH3	Burner reset button and light signalling of lock-out signal
TA	Ignition transformer
TL	Limit thermostat/pressure switch
TS	Safety thermostat/pressure switch
T1	Electronic cam transformer
T2	Additional transformer
Y	Gas regulator valve + gas safety valve
X1	Main terminal supply board
XAZL	Plug for on board display
XPGMax	Maximum gas pressure switch connector

RIELLO

RIELLO S.p.A.
I-37045 Legnago (VR)
Tel.: +39.0442.630111
[http:// www.riello.it](http://www.riello.it)
[http:// www.riello.com](http://www.riello.com)