





RESIDENCE AQUA HM BIS





EN INSTRUCTIONS FOR THE USER, THE INSTALLER AND FOR THE TECHNICAL ASSISTANCE SERVICE





RO INSTRUCȚIUNI PENTRU UTILIZATOR, INSTALATOR ȘI PENTRU SERVICIUL DE ASISTENȚĂ TEHNICĂ

EL ΟΔΗΓΙΕΣ ΓΙΑ ΤΟΝ ΧΡΗΣΤΗ, ΤΟΝ ΕΓΚΑΤΑΣΤΑΤΗ ΚΑΙ ΓΙΑ ΤΗΝ ΥΠΗΡΕΣΙΑ ΤΕΧΝΙΚΗΣ ΒΟΗΘΕΙΑΣ

RIELLO

EN		
1	Warnings and safety 	3
2	Description	3
3	Technical data	4
4	Installation	7
5	Commissioning	12
6	Maintenance and cleaning	18
7	Control panel 	23
8	User instructions 	24
9	General section	76
10	Setting password, access and parameter modification 	82

RO		
1	Avertismente și măsuri de siguranță 	27
2	Descriere	27
3	Date tehnice	28
4	Instalare	31
5	Punerea în funcțiune	36
6	Întreținere și curățare	42
7	Panou de comandă 	47
8	Instrucțiuni de utilizare 	48
9	Secțiunea generală	76
10	Introducerea password, accesul și modificarea parametrilor 	82

EL		
1	Προειδοποιήσεις και ασφάλεια 	51
2	Περιγραφή	51
3	Τεχνικά Χαρακτηριστικά	52
4	Εγκατάσταση	55
5	Θέση σε λειτουργία	60
6	Συντήρηση και καθαρισμός	66
7	Πίνακας ελέγχου 	72
8	Οδηγίες χρήσης 	73
9	Γενική ενότητα	76
10	Ρυθμίσεις κωδικού, πρόσβασης και τροποποίησης παραμέτρων 	82

RESIDENCE AQUA HM BIS boiler complies with basic requirements of the following Directives:

- Regulation (UE) 2016/426
- Efficiency directive: Article 7(2) and Annex III of directive 92/42/EEC
- Electromagnetic compatibility directive 2014/30/EU
- Low-voltage directive 2014/35/EU
- Directive 2009/125/EC Ecodesign for energy-using appliances
- Regulation (EU) 2017/1369 Energy labeling
- Delegated Regul. (EU) No. 811/2013
- Delegated Regul. (EU) No. 813/2013
- UNI/TS 11854 standard.



Centrala termică RESIDENCE AQUA HM BIS respectă cerințele de bază ale următoarelor directive:

- Regulamentul (UE) 2016/426
- Directiva de eficiență: Articolul 7(2) și anexa III din directiva 92/42/CEE
- Directiva de compatibilitate electromagnetică 2014/30/UE
- Directiva 2014/35/UE privind echipamentele de joasă tensiune
- Directiva 2009/125/UE privind cerințele de proiectare ecologică aplicabile aparatelor consumatoare de energie
- Regulamentul (UE) 2017/1369 Etichetarea energiei
- Reglementare delegată (UE) nr. 811/2013
- Reglementare delegată (UE) nr. 813/2013
- Standardul UNI/TS 11854.





Ο λέβητας RESIDENCE AQUA HM BIS συμμορφώνεται με τις ουσιαστές απαιτήσεις των παρακάτω Οδηγιών:

- Κανονισμός (ΕΕ) 2016/426
- Οδηγία αποδόσεων: Είδος 7(2) και Παράρτημα III της 92/42/ΕΟΚ
- Οδηγία ηλεκτρομαγνητικής συμβατότητας 2014/30/ΕΕ
- Οδηγία χαμηλής τάσης 2014/35/ΕΚ
- Οδηγία 2009/125/ΕΚ Οικολογικού σχεδιασμού των προϊόντων που συνδέονται με την ενέργεια
- Κανονισμός (ΕΕ) 2017/1369 Ετικέτα ενέργειας
- Κατ'εξουσιοδότηση κανονισμός (ΕΕ) αρ. 811/2013
- Κατ'εξουσιοδότηση κανονισμός (ΕΕ) αρ. 813/2013
- Πρότυπο UNI/TS 11854.



 **WARNING**
This instructions manual contains data and information for both the user and the installer. Specifically, note that the user, for the use of the appliance, must refer to chapters: Warnings and safety • Commissioning • Maintenance.

 The user must not perform operations on the safety devices, replacing parts of the product, tamper with or attempt to repair the appliance. These operations must be entrusted exclusively professionally qualified personnel.

 The manufacturer is not liable for any damage caused by the non-observance of the above and/or the failure to comply with the regulations.

 **AVERTISMENT**
Prezentul manual de instrucțiuni conține date și informații destinate atât utilizatorului, cât și instalatorului. În mod specific, rețineți că utilizatorul, pentru utilizarea aparatului, trebuie să se refere la capitole: Avertismente și măsuri de siguranță • Punerea în funcțiune • Întreținere.

 Utilizatorul nu trebuie să intervină asupra dispozitivelor de siguranță și nici să înlocuiască părți ale produsului, să desfășoare sau să încerce să repare aparatul. Aceste operații trebuie să fie încredințate exclusiv unor persoane calificate profesional.



 Producătorul nu își asumă răspunderea pentru eventualele daune cauzate de nerespectarea indicațiilor de mai sus și/sau a normelor în vigoare.

 **ΠΡΟΕΙΔΟΠΟΙΗΣΗ**
Αυτό το βιβλιαράκι περιέχει δεδομένα και πληροφορίες που προορίζονται τόσο για το χρήστη όσο και για τον εγκαταστάτη. Πιο συγκεκριμένα, ο χρήστης πρέπει να δώσει ιδιαίτερη σημασία στα κεφάλαια: Προειδοποιήσεις και ασφάλεια • Θέση σε λειτουργία • Συντήρηση.



 Ο χρήστης δεν πρέπει να παρεμβαίνει στα συστήματα ασφαλείας, να αντικαθιστά μέρη του προϊόντος, να κάνει τροποποιήσεις και να προσπαθεί να επισκευάσει τη συσκευή. Αυτές οι εργασίες πρέπει να ζητείται να γίνονται αποκλειστικά και μόνο από ειδικευμένο επαγγελματικό προσωπικό.

 Ο κατασκευαστής δεν φέρει καμία ευθύνη για τυχόν ζημιές που οφείλονται σε μη συμμόρφωση με τα παραπάνω.



In some parts of the booklet, some symbols are used:

-  Section destined for user also.
-  **WARNING** = for actions requiring special care and adequate preparation.
-  **PROHIBITED** = for actions THAT MUST NOT be performed.

În anumite secțiuni ale manualului, sunt utilizate simbolurile:

-  Secțiune destinată de asemenea pentru utilizator.
-  **ATENȚIE** = pentru acțiuni care necesită o atenție deosebită și o pregătire corespunzătoare.
-  **INTERZIS** = pentru acțiuni care NU TREBUIE să fie efectuate.

Στο εγχειρίδιο χρησιμοποιούνται τα ακόλουθα σύμβολα:















-  Μέρος που προορίζεται και για τον χρήστη.
-  **ΠΡΟΣΟΧΗ** = για ενέργειες που απαιτούν ιδιαίτερη προσοχή και κατάλληλη προετοιμασία.
-  **ΑΠΑΓΟΡΕΥΕΤΑΙ** = για ενέργειες που ΑΠΑΓΟΡΕΥΟΝΤΑΙ αυστηρά.



EN	Register the product: scan the QR code or go to "www.myeasycomfort.com"
RO	Scanați codul QR pentru a vă înregistra produsul "www.myeasycomfort.com"
EL	Καταχώρισε το προϊόν: σκάνανε τον κωδικό QR ή μπες στο "www.myeasycomfort.com"

In case of combining the boiler with the DOSSERET kit, it is necessary to program the parameter P520 appropriately (see paragraph "6.1 Programmable parameters")

1 WARNINGS AND SAFETY

-  The boilers manufactured in our factories are checked even in the smallest details in order to protect users and installers against possible injury. After working on the product, qualified personnel must check the electrical wiring, in particular the stripped part of leads, which must not protrude from the terminal board and avoiding possible contact with live parts of the leads themselves.
-  This manual is an integral part of the product: make sure it is always kept with the appliance, even if the latter is transferred to another owner or user, or moved to another heating system. In case of loss or damage, please contact your local Technical Assistance Centre for a new copy.
-  This appliance should not be operated by children under the age of 8, people with reduced physical, sensory or mental capacities, or inexperienced people who are not familiar with the product, unless they are given close supervision or instructions on how to use it safely and are made aware by a responsible person of the dangers its use might entail. Children must not play with the appliance. It is the user's responsibility to clean and maintain the appliance. Children should never clean or maintain it unless they are supervised.
-  The boiler is suitable for use with group H and/or group E fuel gases and mixtures of natural gas and hydrogen up to 20% by volume.
-  Boiler installation and any other assistance and maintenance operation must be carried out by qualified personnel according to the current regulations and in compliance with UNI 7129-7131 and updates.
-  Boiler maintenance must be carried out at least once a year scheduling it with the Technical Service Centres.
-  The installer must instruct the user about how the appliance works, and the essential safety rules.
-  The user must respect the warnings given in this manual.
-  This boiler is intended for the use for which it was expressly designed. The manufacturer accepts no contractual or non-contractual liability for any damage or harm caused to people, animals and property due to installation, adjustment and maintenance errors or to improper use.
-  After removing the packaging, make sure the contents are in good condition and complete. Otherwise, contact the dealer from who you purchased the appliance.
-  The safety valve outlet must be connected to a suitable collection and venting system. The manufacturer disclaims liability for any damage caused by the intervention of the safety valve.
-  Dispose of all the packaging materials in the relative containers at the corresponding collection centres.
-  When disposing of waste, be careful not to harm human health or employ procedures or methods which may damage the environment.
-  At the end of its life, the product should be not be disposed of as solid urban waste, but rather it should be handed over to a differentiated waste collection centre.











During installation, the user must be informed that:

- in the event of water leakage, the water supply must be shut off and the Technical Assistance Centre must be notified without delay
- the operating pressure of the hydraulic system must be checked regularly to ensure it is higher than 1 bar. If necessary, restore pressure by opening the filling tap (the operating pressure of the hydraulic system must be checked regularly to ensure it is higher than 1 bar. If necessary, restore pressure by opening the filling tap (**section 9 - see "Boiler layout"**))
- wait for the pressure to increase: check on the boiler display that the value reaches 1-1.5 bar; then close the filling tap (**section 9 - see "Boiler layout"**).

If the boiler is not used for a long time, you are advised to carry out the following operations:

- set the device to OFF and the main switch of the system to "off"
- close the gas and water taps on both the heating and domestic hot water circuits
- empty the heating and DHW system if there is a risk of freezing.

For reasons of safety remember that:

-  It is forbidden to activate electric devices or appliances such as switches, household appliances and so on if you notice a smell of fuel or unburnt fuel. In this case:
 - ventilate the room by opening the doors and windows;
 - close the fuel shut-off device;
 - arrange for the Technical Assistance Centre or professionally qualified personnel to intervene promptly.
-  It is forbidden to touch the appliance while barefoot or if parts of your body are wet.
-  It is strictly prohibited to carry out any technical or cleaning work before disconnecting the appliance from the power supply by placing the boiler to "OFF" and the also setting the main switch of the system to "OFF".
-  Do not modify the safety or adjustment devices without the manufacturer's authorisation and precise instructions.
-  It is forbidden to pull, detach or twist the electrical cables from the appliance, even if it is disconnected from the mains supply.
-  Do not cover or reduce the size of the ventilation openings in the room where the boiler is installed.
-  It is forbidden to leave flammable containers and substances in the room where the appliance is installed.
-  It is forbidden to leave the packaging material within children's reach, as it may be a potential source of danger. Dispose of it responsibly, in accordance with the legislation in force.
-  It is forbidden to obstruct the condensate drain outlet. The condensate drain pipe should be facing the discharge pipe, preventing the formation of further drain pipes.
-  It is forbidden to intervene in any way on the gas valve.
-  It is forbidden to intervene on sealed elements.

2 DESCRIPTION

RESIDENCE AQUA HM BIS boilers have a new ACC (active combustion control) combustion control system. This innovative control system, developed by Riello, guarantees functionality, efficiency and low emissions in all circumstances. The ACC system uses an ionization sensor immersed in the burner flame which, through its information, allows the control board to act on the gas valve that regulates the fuel. This sophisticated control system allows self-regulation of combustion, eliminating the need for initial calibration of the gas valve. The ACC system is able to adapt the boiler to operate with different gas compositions, different pipe lengths and different altitudes (within the expected design limits). The ACC system is also able to carry out a self-diagnosis which blocks the burner before exceeding emission thresholds higher than the limits allowed by the regulations.

3 TECHNICAL DATA

DESCRIPTION		UM	25 HM BIS		35 HM BIS	
			G20	G31	G20	G31
Heating	Rated heat input	kW-kcal/h	20,00-17.200		30,00-25.800	
	Nominal heat output (80°/60°)	kW-kcal/h	19,53-16.799		29,28-25.181	
	Nominal heat output (50°/30°)	kW-kcal/h	21,31-18.323		31,75-27.302	
	Reduced heat input	kW-kcal/h	2,50-2.150	-	3,50-3.010	-
	Reduced heat output (80°/60°)	kW-kcal/h	2,34-2.009	-	3,36-2.891	-
	Reduced heat output (50°/30°)	kW-kcal/h	2,57-2.213	-	3,71-3.191	-
DHW	Rated heat input	kW-kcal/h	25,00-21.500 I2Y20: 24,00-20.640		34,90-30.014	
	Nominal heat output (*)	kW-kcal/h	25,00-21.500		34,90-30.014	
	Reduced heat input	kW-kcal/h	2,50-2.150	-	3,50-3.010	-
	Reduced heat output (*)	kW-kcal/h	2,50-2.150	-	3,50-3.010	-
Useful efficiency Pn max - Pn min (80°/60°)		%	97,7-93,5		97,6-96,0	
Combustion efficiency		%	98,0		97,8	
Useful efficiency Pn max - Pn min (50°/30°)		%	106,5-102,9		105,8-106,0	
Useful efficiency 30% Pn max (30° return)		%	109,7		109,7	
Total electric power (max power HEATING - DHW.)		W	73-87		87-110	
Circulator electric power (1.000 l/h)		W	43		43	
Category • Country of destination			I12HY203P • (+)		I12HY203P • (+)	
Power supply voltage		V-Hz	230-50		230-50	
Protection level		IP	X5D		X5D	
Heat loss on shut-down		W	30		35	
Losses at the flue with burner off - on		%	0,09-2,04		0,07-2,17	
Heating operation						
Maximum pressure		bar	3		3	
Minimum pressure for standard operation		bar	0,25÷0,45		0,25÷0,45	
Maximum temperature		°C	90		90	
Selection field of heating H2O temperature		°C	40-80 (high) 20-45 (low)		40-80 (high) 20-45 (low)	
Pump: maximum discharge head available for the system at a flow rate of		mbar l/h	450 1.000		450 1.000	
Membrane expansion vessel		l	9		9	
Expansion tank pre-loading (heating)		bar	1		1	
DHW operation						
Maximum pressure		bar	8		8	
Minimum pressure		bar	0,5		0,5	
Quantity of hot water with Δt 25° C		l/min	14,3		20,0	
with Δt 30° C		l/min	11,9		16,7	
with Δt 35° C		l/min	10,2		14,3	
DHW minimum output		l/min	2		2	
Selection field of DHW H2O temperature		°C	37-60		37-60	
Flow regulator		l/min	14		14	
Gas pressure						
Nominal natural gas pressure (G20 - I2H)		mbar	20	-	20	-
Nominal MTN-H pressure (G20.2 - I2Y20)		mbar	-	20	-	20
Nominal LPG pressure (G31-I3P)		mbar	-	-	-	37
Heating flow rate						
Air flow rate		Nm³/h	G20 24,804	G31 24,819	G20 37,206	G31 37,581
Flue gas flow rate		Nm³/h	26,811	26,370	40,216	39,908
Mass flue gas flow rate (max-min)		g/s	9,267- 1,158	9,297- 1,162	13,900- 1,622	14,072- 1,627
DHW flow rate						
Air flow rate		Nm³/h	G20 31,005	G31 31,024	G20 43,284	G31 43,719
Flue gas flow rate		Nm³/h	33,513	32,963	46,784	46,426
Mass flue gas flow rate (max-min)		g/s	11,584- 1,158	11,621- 1,162	16,171- 1,622	16,370- 1,627
Fan performance						
Residual discharge head of concentric pipes 0.85 m		Pa	60		60	
Residual discharge head of separate pipes 0.5 m		Pa	180		195	
Residual discharge head of boiler without pipes		Pa	186		199	
Nox			class 6		class 6	
Maximum permissible emission value (**)			G20	G31	G20	G31
Qn-Qr	CO (0% O2) less than	p.p.m.	230-15	250-20	240-15	240-20
	CO2 (***)	%	8,8-8,8	10,0-10,0	8,8-8,8	9,9-10,0
	NOx (0% O2) less than	p.p.m.	40-30	50-50	30-30	40-40
	Flue gas T	°C	79-60	78-60	82-60	70-57
O2 value relative to the 20% hydrogen mixture	Qmax	max	%		2,4	
		nominal	%		4,3	
		min	%		6,2	
	Qmin	max	%		2,4	
		nominal	%		4,3	
		min	%		6,2	

(*) Average value of various hot water operating conditions

(**) Test carried out with Ø60-100 concentric pipe, length 0.85m. - in heating, water temperature 80-60°C - values measured with the casing completely closed. Depending on the type of flue system, CO values may differ from those declared. If the level exceeds 500 ppm, urgently request intervention from the Technical Assistance Service

(***) Tolerance CO2= ±1%

(+) The installation of this product is allowed only in the destination Countries contained in the data plate, regardless of the present translation language. The data expressed must not be used to certificate the system; for certification use the data indicated in the "System handbook" measured during first ignition.

VALUES RELATING TO DHW PERFORMANCE WITH A STORAGE CYLINDER WITH A DOSSERET KIT INSTALLATION (AVAILABLE UPON REQUEST)

Description		25 HM BIS	35 HM BIS
Storage cylinder type	∅	Inox	Inox
Storage cylinder arrangement	∅	Vertical	Vertical
Heat exchanger arrangement	∅	external, plate	external, plate
Vnom, effective DHW content	l	31	31
DHW temperature selection range	°C	37-60	37-60
Quantity of water draw-off in 10 minutes with a minimum Dt of 30°C	l	119	167
Storage cylinder maximum operating pressure	bar	10	10
Vbu, non-solar storage tank volume	l	31	31
Specific flow rate according to EN13203-1	l/min	14,3	18,1

PARAMETERS	UM	METHANE GAS (G20)		LPG (G31)	
Lower Wobbe index (at 15°C-1013 mbar)	MJ/m³S	45,67		70,69	
Net calorific value	MJ/m³S	34,02		88	
Nominal supply pressure	mbar (mm H2O)	20 (203,9)		37 (377,3)	
Minimum supply pressure	mbar (mm H2O)	13 (132,6)		-	
		25 HM BIS	35 HM BIS	25 HM BIS	35 HM BIS
Burner: diameter/length	mm	70/80,5	70/95	70/80,5	70/95
Maximum gas flow rate (heating)	Sm³/h	2,12	3,17	-	-
	kg/h	-	-	1,55	2,33
Maximum gas flow rate (DHW)	Sm³/h	2,64	3,69	-	-
	kg/h	-	-	1,94	2,71
Minimum gas flow rate (heating)	Sm³/h	0,26	0,37	-	-
	kg/h	-	-	0,19	0,27
Minimum gas flow rate (DHW)	Sm³/h	0,26	0,37	-	-
	kg/h	-	-	0,19	0,27
Maximum number of fan rotations (heating)	rpm	6.300	7.400	6.100	7.100
Maximum number of fan rotations (DHW)	rpm	7.900	8.600	7.600	8.200
Minimum number of fan rotations (heating - DHW)	rpm	1.200	1.300	1.250	1.250
Max. nr. of fan rotations (heating) in C(10)3 configuration (∅80/125 • ∅80-80)	rpm	6.500	7.600	-	-
Max. nr. of fan rotations (DHW) in C(10)3 configuration (∅80/125 • ∅80-80)	rpm	8.100	8.600	-	-
Min. nr. of fan rotations (heating-DHW) in C(10)3 configuration (∅80/125 • ∅80-80)	rpm	2.100	2.200	-	-

NOTE: in the first 10 hours of burner operation, the minimum will never go below 1400 rpm (for both the 25 and 35kW); 1600 rpm if LPG.

Description	Boiler type RESIDENCE AQUA HM BIS					
	25 BIS	35 BIS	25 BIS	35 BIS	25 BIS	35 BIS
	C4		C6		C8	
Technical data for typical installations:						
Temperature of combustion products @ Nominal heat output (at 80/60° C) - [°C]	63	63,8	63,5	63,9	49,7	56,3
Mass flow rate [kg/h] @ Nominal heat output [kW]	2,759	3,823	2,743	4,089	2,833	3,944
Nominal heat output [kW]	25,8	35,67	25,55	38,4	26,46	36,82
Overtemperature of the flue gases [°C]	115					
Temperature of the flue gases at minimum heat output [°C]	35,6	39,5	57,6	60,1	35,8	37,4
Mass flow rate [kg/h] @ Minimum heat output [kW]	0,545	0,694	0,305	0,422	1,036	1,187
Minimum heat output [kW]	5,14	6,52	2,87	4	9,74	11,1
CO2 content @ Nominal heat output [%]	8,42	8,56	10,00	10,40	5,62	5,92
CO2 at minimum heat output [%]	3,12	3,04	9,08	9,26	2,65	2,56
Loss of minimum permitted pressure (in air feed and flue gas pipe) [Pa]	4,4	8,3	-	-	-	-
Loss of maximum permitted pressure (in air supply and flue gas pipe) [Pa]	180	195	-	-	-	-
Maximum permitted pressure difference between combustion air inlet and flue gas outlet (including wind pressure) [Pa]	-	-	4,4	8,3	-	-
Maximum permitted combustion air temperature [°C]	-	-	45	45	-	-
	C9		25 BIS - 35 BIS			
Minimum useful diameter of the flue/vertical technical compartment for combustion air supply [mm]	240					

Notes

- C1:** for the installation of the terminals on the wall and roof, refer to the specific instructions contained in the kits the terminals emerge from separate combustion and air supply circuits within a square area of 50 cm
- C3:** the terminals of the separate combustion and air supply circuits must lie within a square area of 50 cm, and the distance between the surfaces of the two holes must be less than 50 cm
- C4:** the boilers in this configuration, with the relative connection pipes, can be connected to only one natural draught stack; condensate flow inside the appliance is not permitted
- C5:** the terminals for combustion air supply and the evacuation of flue gases must not be installed on opposite walls of the building
- C6:** condensate flow inside the appliance is permitted
maximum permitted recirculation rate of 10% in windy conditions
the terminals for combustion air supply and the evacuation of flue gases must not be installed on opposite walls of the building
the appliance must not be connected to a common flue (i.e., more than one appliance on a shared flue) operating under positive pressure.

 **This type of configuration is not permitted in some countries; refer to the local regulations in force**

- C8:** condensate flow inside the appliance is not permitted

3.1 Erp data

Parameter	Symbol	25 HM BIS	35 HM BIS	Unit
Seasonal space heating energy efficiency class	-	A	A	-
Water heating energy efficiency class	-	A	A	-
Rated heat output	P _{nominal}	20	29	kW
Seasonal space heating energy efficiency	η _s	94	94	%
Useful heat output				
At rated heat output and high-temperature regime (*)	P ₄	19,5	29,3	kW
At 30% of rated heat output and low-temperature regime (**)	P ₁	6,6	9,9	kW
Useful efficiency				
At rated heat output and high-temperature regime (*)	η ₄	87,9	87,9	%
At 30% of rated heat output and low-temperature regime (**)	η ₁	98,8	98,8	%
Auxiliary electricity consumption				
At full load	el _{max}	30,0	44,3	W
At part load	el _{min}	12,2	13,6	W
In Stand-by mode	PSB	3,0	3,0	W
Other parameters				
Stand-by heat loss	P _{stby}	30,0	35,0	W
Pilot flame energy consumption	P _{ign}	-	-	W
Annual energy consumption	Q _{HE}	60	90	GJ
Sound power level, indoors	L _{WA}	48	47	dB
Emissions of nitrogen oxides	NO _x	22	35	mg/kWh
For combination heaters				
Declared load profile		XL	XL	
Water heating energy efficiency	η _{wh}	85	87	%
Daily electricity consumption	Q _{elec}	0,173	0,102	kWh
Daily fuel consumption	Q _{fuel}	23,014	22,524	kWh
Annual electricity consumption	AEC	38	22	kWh
Annual fuel consumption	AFC	17	17	GJ

(*) High-temperature regime means 60 °C return temperature at heater inlet and 80 °C feed temperature at heater outlet





(**) Low temperature means for condensing boilers 30 °C, for low-temperature boilers 37 °C and for other heaters 50 °C return temperature (at heater inlet)



For combined heating appliances: BOILER WITH DOSSERET

Parameter	Symbol	25 HM BIS	35 HM BIS	Unit
Load profile		XL	XL	
Daily electricity consumption	Q _{elec}	0,352	0,354	kWh/h
Annual electricity consumption	AEC	77	78	kWh
Water heating energy efficiency	η _{wh}	80	82	%
Daily fuel consumption	Q _{fuel}	23,964	23,370	kWh
Annual fuel consumption	AFC	18	18	GJ

(*) High-temperature regime means 60°C return temperature at heater inlet and 80°C feed temperature at heater outlet

(**) Low temperature means for condensing boilers 30°C, for low-temperature boilers 37°C and for other heaters 50°C return temperature (at heater inlet)

RIELLO		RIELLO S.p.A. - Via Ing. Pilade Riello, 7 - 37045 Legnago (Vr)					
						0476/00	
RESIDENCE AQUA HM BIS		D: l/min	Q _{nw}	Q _n 80-60 °C	Q _m 80-60 °C	Q _n 50-30 °C	
Serial N.		COD.					
230 V ~ 50 Hz	W		NO _x :	Q _n (Hi) =	kW	kW	kW
	P _{mw} = bar	T = °C	IP	P _n =	kW	kW	kW
	P _{ms} = bar	T = °C					

EN	
Q _{nw}	DHW nominal output
Q _n	Heating nominal output
Q _m	Heating minimum output
Q _n (Hi)	Nominal output (NET Calorific Value)
P _n	Nominal output
 P _{ms}	Heating maximum operating pressure
 P _{mw}	DHW maximum operating pressure
T	Temperature
IP	Protection level
NO _x	NO _x class
D	Specific output

Refer to the specific instructions in the kit for further details.

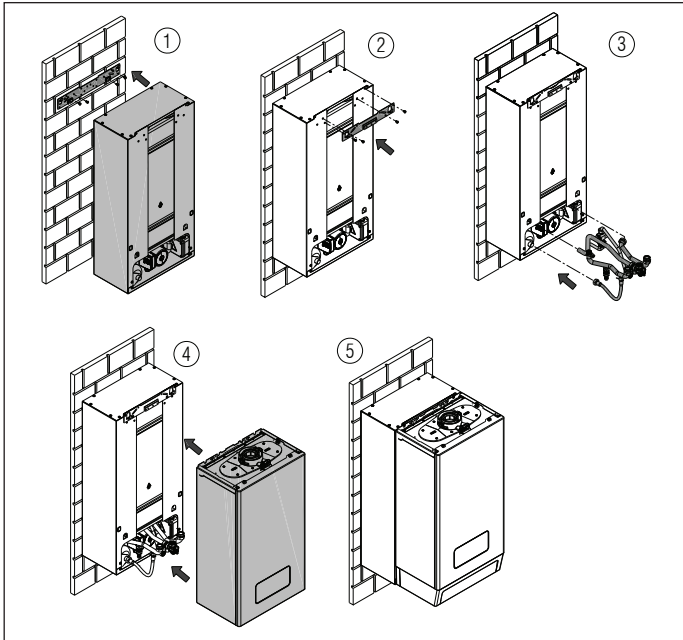

The storage cylinder with bi-tank storage technology has the same performance levels as 45 and 60-litre coil storage cylinders, but with considerably smaller dimensions. By using the parameter in the electronics, it is possible to exclude the storage tank function, operating the boiler in the instant mode setting.

P520 = 1 storage cylinder, DHW storage tank

P520 = 0 storage cylinder function disabled, the boiler runs in instant mode, ensuring savings on gas consumption

The parameter **P521** manages the storage cylinder reset frequency:

COMFORT with the COMFORT setting, the boiler has greater and more frequent storage cylinder filling cycles. This setting, for which the boiler has been designed in terms of better performance, is typical of domestic applications where the sanitary performance aspect of the system is prioritized..

ECO the ECO setting causes the boiler to have a reduced number of storage cylinder reset cycles. This choice should be made when you want greater energy savings but limit the sanitary performance of the system.

⚠ The parameters indicated above must be set before the boiler is used.

⚠ In the OFF state, the storage cylinder reset cycle is disabled. The storage cylinder reset cycle temporarily suspends the room heating cycle.

⚠ During a storage cylinder filling cycle, the boiler display shows TCHG (with P105 = 1 scrolling message --> TANK CHARGE).

⚠ A filling cycle is carried out after a power on, approximately 3 minutes after a DHW request, when there is a changeover from the OFF status to the SUMMER/WINTER status, at the end of the DHW time programmer (POS).

If there is a no communication between the boiler board and the dossier kit (BUS connection 485 - for details refer to instructions in the dossier kit), the display shows the indication E066 (with P105 = 1 scrolling message --> DOSSERET COMMUNICATION FAIL). The boiler is forced into the off state.

⚠ In the event of a malfunction of the sanitary circulator in the DOSSERET, such as its electrical or mechanical block, the system does not provide any warnings. In this case, both a worsening of sanitary performance and a failure of the heating system may occur. The technical assistance service may temporarily disable the DOSSERET functionality (P520=0) for the time necessary to replace the sanitary circulator in the DOSSERET.

⚠ If there is no communication between the boiler board and the adjustments board, the storage cylinder reset mode is stopped.

To complete the installation, use the accessories kit below:

- hydraulic pipes
- flow switch with pipes
- fitting cover
- compact polyphosphate dispenser (in case of boiler with built-in dispenser).

For more information refer to the catalog.

4.4 Instructions for the condensate discharge connection

This product is designed to prevent the escape of flue gaseous through the condensate drainage pipe with which it is equipped; this is achieved through the use of a special drain-trap located inside the appliance.

⚠ All the components of the condensate drainage system must be correctly serviced as per the manufacturer's indications, and must not be modified in any way.

The condensate drain outlet system downstream from the appliance must be made in accordance with the relevant legislation and regulations in force; this is the responsibility of the installer. The system must be sized and installed so as to ensure the correct evacuation of the condensate produced by the appliance and/or collected by the flue gas evacuation systems. All the system components must be made to the highest standards, using materials able to withstand the long-term mechanical, thermal and chemical stress created by the condensate.

Note: if the condensate drain outlet system is exposed to the risk of freezing temperatures, always ensure a suitable level of pipe insulation and consider increasing the diameter of the pipe itself.

The pipe must slope sufficiently to prevent the condensate from stagnating and guarantee it is correctly drained off. There must be an examinable disconnection between the condensate drain outlet pipe of the appliance and the condensate drain outlet system.

4.5 Access to electrical parts

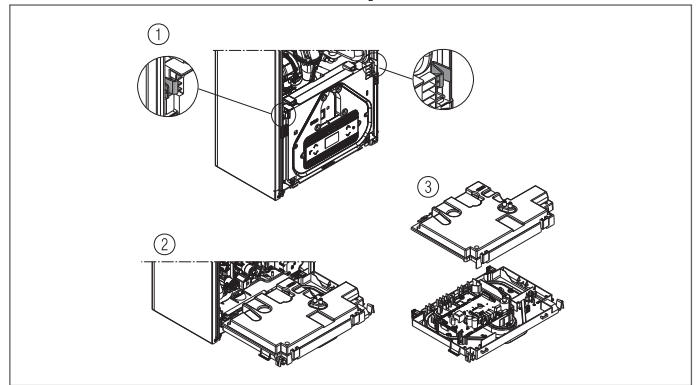

4.6 Electrical wiring

Low voltage connections

Make the low voltage connections as follows:

- use the connectors supplied:
 - ModBus 4-pole connector for the BUS 485 signal (- A B +)
 - 8-pole connector for TBT - TA - OT+ - SE signals

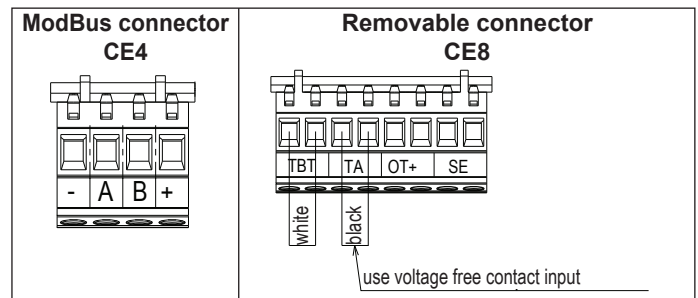

CE4	(- A B +)	Bus 485
	TBT	Low temperature thermostat
CE8	TA	Room thermostat (contact without voltage)
	OT+	Open therm
	SE	Outdoor temperature sensor

- make the electrical connections using the desired connector as shown in the detail drawing
- after making the connections, insert the connector in its counterpart.

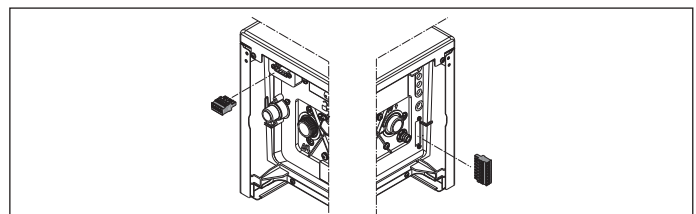

⚠ It is recommended to use conductors with wire cross-sections from a minimum of 0.35mm² to a maximum of 1.5mm². To connect the BUS 485 it is recommended to use the shielded cable if the signal passes near other electrical conductors or mains voltage conductors (230V).

⚠ In case of a TA or TBT connection, remove the relative jumpers on the terminal board.

NOTE: when connecting an OT+ remote control to the system, if the parameter P803= 1 (SERVICE), the boiler display shows the following screen:



Note: Full compatibility with third-party OpenTherm devices is not guaranteed.

Please note that, if OT+ remote control connected:

- it is no longer possible to set the boiler OFF/WINTER/SUMMER status (which can now be set via the OT+ remote control)
- it is no longer possible to set the DHW setpoint (which can now be set via the OT+ remote control)
- the combination of buttons **A+B** remains active in order to set the COMFORT function
- the DHW setpoint value (I005) is displayed in the INFO menu
- the heating setpoint value calculated by remote control OT+ (I017) is displayed in the INFO menu
- it is only possible to set the heating setpoint in the boiler if P311=1 or P311 = 0 and jumper closed. The value can be seen in the INFO menu (I016)
- to activate the COMBUSTION ANALYSIS function, with OT+ remote control connected, the connection must be temporarily disabled by setting the parameter P803 = 0 (SERVICE); remember to reset the value of this parameter after using the function.

Key 2 remains active for resetting the alarm.

Key 3 remains active for displaying the INFO menu and enabling the SETTINGS menu.

High voltage connections

The connection to the mains supply must be made via a separation device with an omnipolar opening of at least 3.5 mm (EN 60335/1 - category 3). The appliance works with alternating current at 230 Volt/50 Hz, and is in compliance with Standard EN 60335-1. It is obligatory to make the connection with a safe ground/earth, in compliance with current directives.

- ⚠ The installer is responsible for ensuring the appliance is suitably earthed; the manufacturer will not be liable for any damage resulting from an incorrect or absent earth connection.
- ⚠ It is also recommended to uphold the phase-neutral connection (L-N).
- ⚠ The ground/earth wire must be a couple of cm longer than the others.
- ⚠ To create the seal of the boiler use a clamp and tighten it on the cable grommet used.

The boiler can operate with a phase-neutral or phase-phase supply. It is forbidden to use gas and/or water pipes to earth electrical appliances. Use the power cable supplied to connect the boiler to the mains power supply. If the power cable has to be replaced, use a HAR H05V2V2-F cable, 3 x 0.75mm², Ø max external 7 mm.

4.7 Gas connection

The connection of the gas supply must be carried out in compliance with current installation standards. Before making the connection:

- check that the gas supplied corresponds to that for which the boiler has been prepared (see nameplate).

4.8 Removing the casing

To access the internal components, remove the casing as shown below.

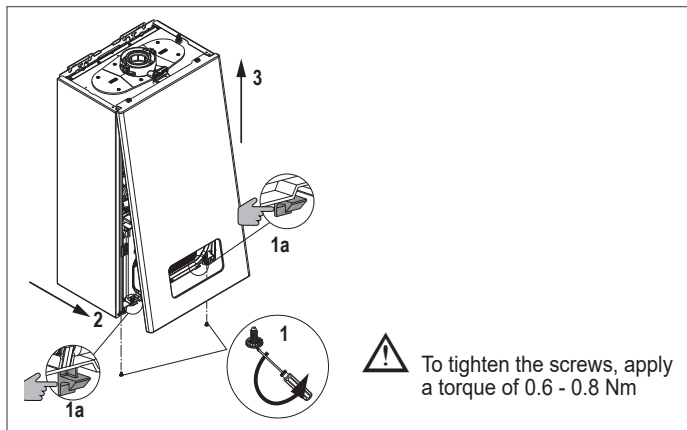

⚠ If the side panels are removed, refit them in their initial position, referring to the label on the panel itself.

⚠ If the front panel is damaged, it must be replaced.

⚠ The noise-absorbing panels in the front and side walls ensure the airtight seal of the air supply pipe in relation to the place of installation.

⚠ It is therefore ESSENTIAL that components are repositioned correctly after disassembly in order to guarantee the tightness of the boiler.

4.9 Flue gas exhaust and combustion air suction

To evacuate the combustion products, refer to UNI 7129-7131. Always comply with the local regulations of the fire brigade and gas company, and with any possible municipal regulations.

It is essential for flue gas evacuation and boiler combustion air transfer that only original pipes are used (apart from type C6, as long as it is certified), and that the connection is made as explained in the instructions supplied with the flue gas accessories. A single flue can be connected to several appliances provided that every appliance is the condensing type.

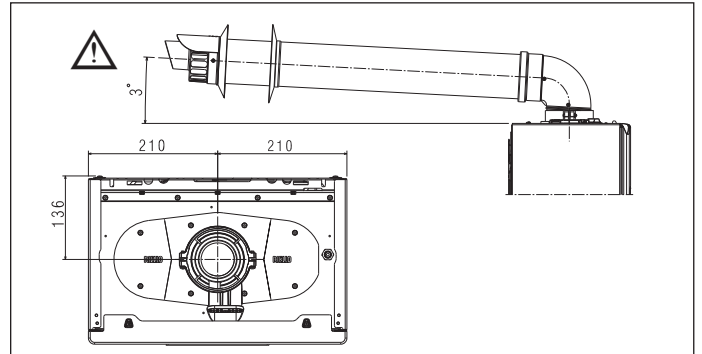

⚠ The boiler flue gas turret is sized for a concentric duct with an external diameter of the flue pipe of 60 +0.6 -0.3 mm and an external diameter of the air pipe of 100 +0.3 -0.7 mm. Make sure that the coupling is watertight.

⚠ Do not install flue gas outlets near flammable or plastic materials, the characteristics of which can be changed at high temperatures.

⚠ The straight length is understood to be without bends, and includes ends and joints.

⚠ The boiler is supplied without the flue gas/air suction kit, as it is possible to use the accessories for condensing appliances best suited to the installation characteristics (refer to the catalogue).

⚠ If non-original flue gas and air inlet pipes are used, it must be ensured that the pipes used are certified and comply with the appliance to which they are connected, have a temperature class $\geq 120^{\circ}\text{C}$ and are resistant to condensation.

⚠ To ensure the best installation safety, attach the pipes to the wall (or ceiling) using specific fixing brackets positioned in line with each joint (at a distance such that the length of each single extension is not exceeded) and immediately before and after every change of direction (bend).

⚠ The maximum lengths of the pipes refer to the flue accessories available in the catalogue.

⚠ It is compulsory to use specific pipes.

⚠ Heat-sensitive walls such as those made from wood should be protected with suitable insulation.

⚠ The non insulated flue gas outlet pipes are potential sources of danger.

⚠ The use of a longer pipe causes a loss of output of the boiler.

⚠ The exhaust pipes can face in the direction most suited to the installation requirements.

⚠ As envisaged by current legislation, the boiler is designed to take in and dispose of flue gas condensate and/or meteoric water condensate deriving from the flue gas discharge system using its own siphon.

⚠ If a condensate relaunch pump is installed, check the technical data (provided by the manufacturer) regarding output, to ensure it operates correctly.

- Position the discharge pipe so the connection is fully up against the flue gas turret of the boiler.
- Once positioned, ensure that the 4 notches (A) engage in the appropriate groove (B).
- Fully tighten screws (C) tightening the two clamps of the flange so that the bend is secured.

For the lengths of the outlets, please refer to the chapter "Flue gas outlet configuration table" on pages 81-82.

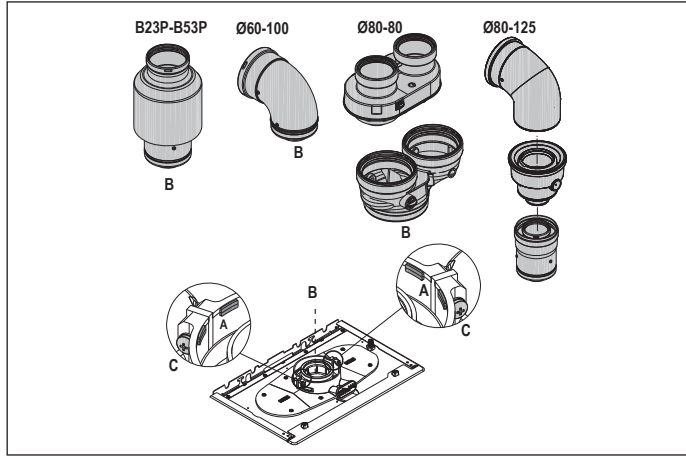

Twin system using the Ø80 twin system connection kit (accessory)

! The connections of the Ø 80 split system connection kit are sized for ducts with an external diameter of 80 +0.3 -0.7 mm. Make sure that the coupling is watertight.

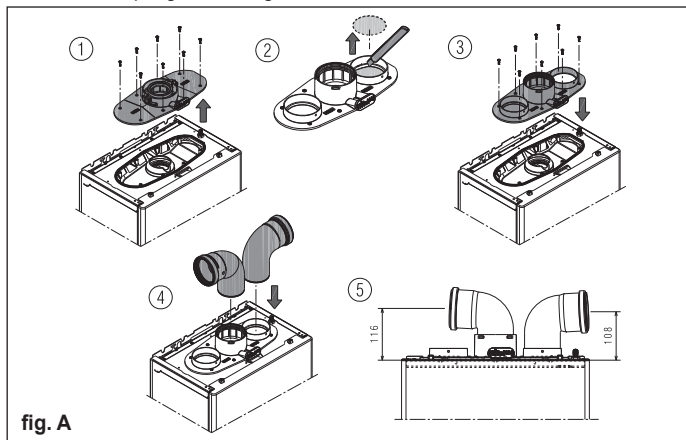

If the Ø 60-100 to Ø 80-80 twin pipe kit is used instead of the twin pipe system, there is a loss in the maximum lengths as shown in the table.

	Ø 50	Ø 60	Ø 80
Loss of length (m)	0,5	1,2	5,5 for flue gas pipe 7,5 for air pipe

Twin pipes with Ø 80 pipework Ø50 - Ø60 - Ø80

Thanks to the boiler characteristics, a Ø80 flue gas discharge pipe can be connected to the Ø50 - Ø60 - Ø80 ducting ranges.

! For the ducting, you are advised to make a project calculation in order to respect the relevant standards in force.

The table shows the standard configurations allowed.

Table of standard pipe configurations (*)

Air suction	1 90° bend ø 80 4.5m pipe ø 80
Flue gas exhaust	1 90° bend ø 80 4.5m pipe ø 80
	Reduction from ø 80 to ø 50 or from ø 80 to ø 60 90° stack base curve ø 50 or ø 60 or ø 80 For ducting pipe lengths see table

(*) Use plastic ducting (PP) suitable for condensing boilers and with a pressure class (P1 up to 200 Pa - H1 up to 5000 Pa) suitable for the application, referring to the boiler outlet DP value given in "Regulation tables".

The boilers are factory set to:

		CH rpm	DHW rpm	max length pipes (m)		
				Ø50	Ø60	Ø80
25 HM BIS		6.300	7.900	7	23	116
				6	20	98
35 HM BIS		7.400	8.600	2	12	62
				1	11	57

Should greater lengths be required, compensate the pressure drop with an increase in the r.p.m. of the fan, as shown in the adjustments table, to provide the rated heat input.

! The minimum calibration is not modified.

Adjustment tables INSIDE CHIMNEY PIPES - G20

		twin flue pipe				
	Fan rotations rpm	Pipes Ø 50	Pipes Ø 60	Pipes Ø 80	ΔP at boiler outlet (Pa)	
		CH	DHW	Maximum length (m)		
25 HM BIS	6.300	7.900	7	23	116	180
	6.400	8.000	9*	29*	144*	210*
	6.500	8.100	11*	34*	172*	257*
	6.600	8.200	14*	40*	201*	285*
	6.700	8.300	16*	46*	229*	330*
	6.800	8.400	18*	51*	257*	355*
	6.900	8.500	21*	57*	285*	385*
	7.000	8.600	23*	63*	314*	425*
	7.100	8.700	25*	68*	342*	465*
	7.200	8.800	28*	74*	370*	497*
35 HM BIS	7.400	8.600	2	12	62	195
	7.500	8.700	4*	18*	92*	242*
	7.600	8.800	6*	24*	119*	289*
	7.700	8.900	9*	29*	145*	337*
	7.800	9.000	11*	34*	172*	384*

(*) Maximum length that can be installed ONLY with class H1 discharge pipes.

		compact twin flue pipe				
	Fan rotations rpm	Pipes Ø 50	Pipes Ø 60	Pipes Ø 80	ΔP at boiler outlet (Pa)	
		CH	DHW	Maximum length (m)		
25 HM BIS	6.300	7.900	6	20	98	170
	6.400	8.000	8*	25*	124*	203*
	6.500	8.100	10*	30*	150*	235*
	6.600	8.200	13*	35*	176*	268*
	6.700	8.300	15*	40*	202*	300*
	6.800	8.400	17*	46*	228*	333*
	6.900	8.500	19*	51*	253*	365*
	7.000	8.600	21*	56*	279*	398*
	7.100	8.700	23*	61*	305*	430*
	7.200	8.800	25*	66*	331*	463*
35 HM BIS	7.400	8.600	1	11	57	180
	7.500	8.700	3*	17*	84*	227*
	7.600	8.800	6*	22*	111*	274*
	7.700	8.900	8*	28*	138*	322*
	7.800	9.000	10*	33*	165*	369*

(*) Maximum length that can be installed ONLY with class H1 discharge pipes.

The Ø50 or Ø60 or Ø80 configurations contain Lab test data. In the event of installations that differ from the indications in the "standard configurations" and "adjustments" tables, refer to the equivalent linear lengths below.

! In any case, the maximum lengths declared in the booklet are guaranteed, and it is essential not to exceed them.

COMPONENT	Linear equivalent in metres Ø80 (m)	
	Ø 50	Ø 60
bend 45°	12,3	5
bend 90°	19,6	8
0.5m extension	6,1	2,5
1.0m extension	13,5	5,5
2.0m extension	29,5	12

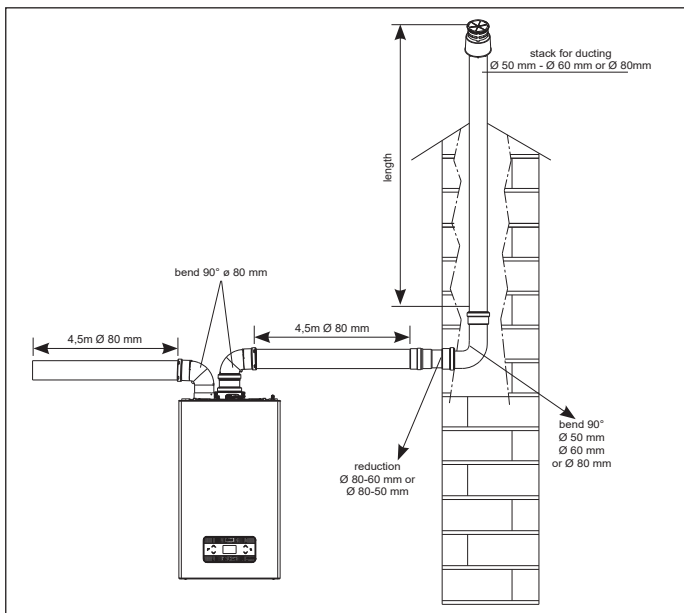

4.10 Installation on collective flues in positive pressure

The collective flue is a system suitable for collecting and expelling the combustion products of several appliances installed on several floors of a building. Positive pressure flues may only be used for type C condensing appliances. Consequently the B53P/B23P configuration is prohibited. The installation of boilers on pressurised collective flues is **only permitted for methane gas**. The boiler is sized to work correctly up to a maximum internal smoke pipe pressure of 25 Pa. Check the number of fan rotations complies with the indications in the "technical data" table.

Make sure the air suction and flue gas discharge pipes are airtight. Installation in pressurized collective flues is only possible by using the clapet accessory kit with integrated siphon, to be installed immediately on the exit of the flue gas discharge pipe (kit Ø80) or the flue gas discharge/suction air pipe (kit Ø80/125).

NOTE: The use of the Ø80 clapet kit requires the use of the Ø80 twin system connection kit (fig. A - 2, page 10).

The clapet accessory kits with integrated siphon available in the catalog are suitable for the collection and flow of condensate inside the boiler.

WARNINGS:

- ⚠ The appliances connected to a joint flue must all be of the same type and have equivalent combustion characteristics.
- ⚠ The number of appliances that can be connected to a collective smoke pipe under positive pressure is defined by the smoke pipe designer.

The boiler is designed to be connected to a collective smoke pipe sized to work in conditions where the static pressure of the collective flue gas pipe may exceed the static pressure of the collective air pipe by 25 Pa when n-1 boilers are working at the maximum nominal heat output while 1 boiler is working at the minimum heat output permitted by the controls.

- ⚠ The minimum permitted pressure difference between the flue gas outlet and the combustion air inlet is -200 Pa (including -100 Pa of wind pressure).

The maximum permissible flue gas pipe and air intake pipe lengths are shown in chapter "4.9 Flue gas exhaust and combustion air suction".

- ⚠ The installation of the non-return valve (clapet kit), available in the catalogue, is mandatory.
- ⚠ The pipes must be assembled so as to avoid pockets of condensate that would prevent the correct evacuation of the flue gases.
- ⚠ A data plate must be positioned in the point of connection with the collective flue gas pipe. The plate must show at least the following information:
 - the collective flue is sized for boilers type C(10)3
 - the maximum mass flow rate permitted for the flue gases, kg/h
 - the dimensions of the connection to the shared pipes
 - a warning concerning the air outlet and combustion product input openings of the pressurised collective flue; these openings must be closed and a check must be made when the boiler is disconnected, to make sure they are airtight
 - the name of the manufacturer of the collective flue gas pipe, or the company's logo.

⚠ See applicable legislation for the discharge of the combustion products as well as local regulations.

⚠ The flue gas pipe must be carefully chosen on the basis of the following parameters.

	maximum length	minimum length	UM
Ø 80-80	4,5 + 4,5	0,5	m
Ø 80/125	4,5	0,5	m

⚠ Before attempting any operation, disconnect the appliance from the electrical supply.

⚠ Before assembling, lubricate the gaskets with a non-corrosive glide lubricant.

⚠ If the flue gas discharge pipe is horizontal, it must be tilted 3° towards the boiler.

⚠ The number and characteristics of the appliances connected to the smoke pipe must be suitable for the real characteristics of the pipe itself.

⚠ The terminal of the collective pipe must create a draught.

⚠ The condensate can flow inside the boiler.

⚠ The maximum permitted recirculation rate in windy conditions is 10%.

⚠ The maximum permitted pressure difference (25 Pa) between the flue gas inlet and the air outlet of a collective smoke pipe cannot be exceeded when n-1 boilers are working at the maximum nominal heat output while 1 boiler is working at the minimum heat output permitted by the controls.

⚠ The collective flue gas pipe must be suitable for an overpressure value of at least 200 Pa.

⚠ The collective flue must not be equipped with a draught-breaking device.

Bends and extensions, available as accessories, can be installed according to the desired type of installation.

The maximum permissible flue gas pipe and air intake pipe lengths are shown in chapter "4.9 Flue gas exhaust and combustion air suction".

With C(10)3 installation, show the number of fan rotations (rpm) on the label applied alongside the appliance serial number.

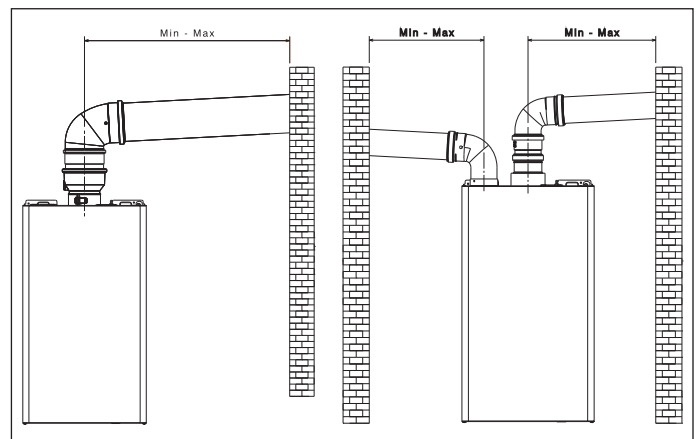

4.11 Filling the heating system and removing air

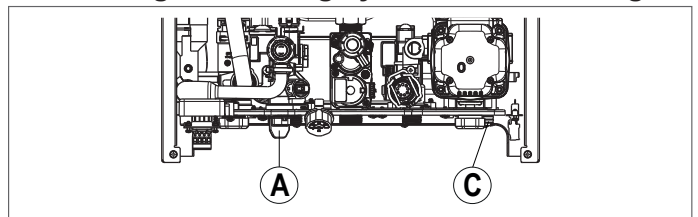

NOTE: operations for **filling** the system must be carried out using the filling tap (A) ensuring that the boiler is electrically powered.

NOTE: whenever the boiler is powered electrically, the **automatic vent cycle** is carried out.

NOTE: the presence of a water alarm (E040, E041 o E042) does not allow the vent cycle to be performed.

Proceed to filling the heating system by carrying out the following steps:

- open the filling tap (A) by turning it anticlockwise
- check that the pressure value reaches 1-1.5 bar by means of a hydrometer placed under the bracket
- close the filling tap (A).

NOTE: if the mains pressure is less than 1 bar, keep the filling tap open (A) during the vent cycle and close it once finished.

To **start** the vent cycle:

- switch off the power supply for a few seconds
- connect the power again leaving the boiler OFF
- check that the gas tap is closed.

At the **end** of the cycle, if the circuit pressure has decreased, act on the filling tap again (A) to bring the pressure to the recommended value (1-1.5 bar).

After the vent cycle, the boiler is ready.

- Remove any air in the domestic system (radiators, zone manifolds, etc.) using the bleed valves.
- Once again check that the system pressure is correct (ideally 1-1.5 bar), restoring the right level if necessary.
- If air is noticed when operating, repeat the vent cycle.
- Once the operations are finished, open the gas tap and ignite the boiler.

At this point it is possible to carry out any heat request.

4.12 Emptying the boiler heating circuit

Before draining, set the boiler to OFF and shut off the electrical supply setting the main system switch to OFF.

- Close the heating system taps (if present).
- Connect a pipe to the system drain tap (C), then manually turn it anticlockwise to drain off the water.

NOTE: act on the system drain tap (C) with a size 13 wrench
- When finished, remove the pipe from the system drain tap (C) and close it.

4.13 Emptying the boiler DHW circuit

Whenever there is a risk of freezing, the DHW system must be emptied as follows:

- turn off the main water supply tap
- turn on all the hot and cold water taps
- drain the lowest points.

5 COMMISSIONING

5.1 Preliminary checks

The first start-up must be carried out by personnel from the relevant Technical Assistance Centre. Before starting up the boiler, check:

- that the data of the supply networks (electricity, water, gas) correspond to the label data
- that the flue gas evacuation and air intake pipes comply with current regulations and respect the maximum permissible lengths
- that conditions for regular maintenance are guaranteed if the boiler is placed inside or between items of furniture
- the seal of the fuel adduction system
- that the fuel flow rate corresponds to values required by the boiler
- that the fuel supply system is sized to provide the correct flow rate to the boiler, and that it has all the safety and control devices required by current regulations
- that the circulator rotates freely because, especially after long periods of inactivity, deposits and/or debris can prevent free rotation
- that the trap is completely filled with water, otherwise refill it (see chapter "5.2 Initial start-up").

5.2 Initial start-up

On first start-up, in the event of prolonged non-use and in the event of maintenance work, it is essential to proceed as described in the following paragraphs before putting the appliance into operation. At the first start-up, the calibration procedure (GAC) is also recommended to allow the boiler to reach its optimal performance. If the procedure is not performed, for 60 seconds every 10 minutes the display shows "CFG" (with P105 = 1 scrolling message --> CALL FOR GAC):



5.2.1 Condensate trap filling

Fill the condensate collection drain-trap, pouring about 1 litre of water into the boiler combustion analysis outlet, and check that:

- the water leaving the boiler via the discharge tube is running off correctly
- the seal on the condensate discharge connection line.

Proper functioning of the condensate drainage circuit (drain-trap and pipes) requires that the condensate level does not exceed the maximum level (max).

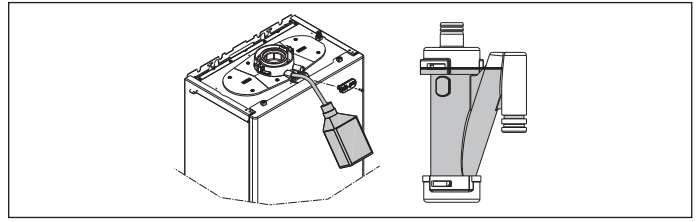

5.3 Venting cycle

Turn the main system switch ON.

Every time the boiler is energised, a 4-minute vent cycle is performed. The display appears as follows (with P105 = 1 scrolling message --> AIR PURGING CYCLE IN PROGRESS):



To interrupt the vent cycle press .

 When the vent cycle is running all heat requests are inhibited except for DHW requests when the boiler is not in OFF.

The cycle can also be interrupted by a DHW request, if the boiler is not OFF.

5.4 Manual calibration procedure (GAC)

The GAC procedure, which is useful to calibrate the gas valve and combustion control system, is mandatory following: gas conversion - gas valve replacement - board replacement - fan replacement - cleaning of primary heat exchanger and/or burner - replacement of flame detection electrode (ionisation) - modification of suction/exhaust pipes - cleaning the conveyor, cleaning the fan, cleaning the mixer fan filter, replacing the exchanger, replacing the exchanger and conveyor assembly.

The GAC procedure must also be carried out on first start-up. If this procedure is not carried out in the time required, the boiler will still be safe however it may be limited in performance and may also process combustion control signals.

 **The procedure must be performed with the casing closed.**

Any repetition of the GAC that is not successfully completed leaves the system in the "GAC not completed" condition.

The system alternates (except when signalling ALARM, INFO and PROGRAMMING) the normal display with the word "CFG" (with P105 = 1 scrolling message --> CALL FOR GAC) as a reminder that the GAC is required and that therefore the boiler may have limitations in its operation.

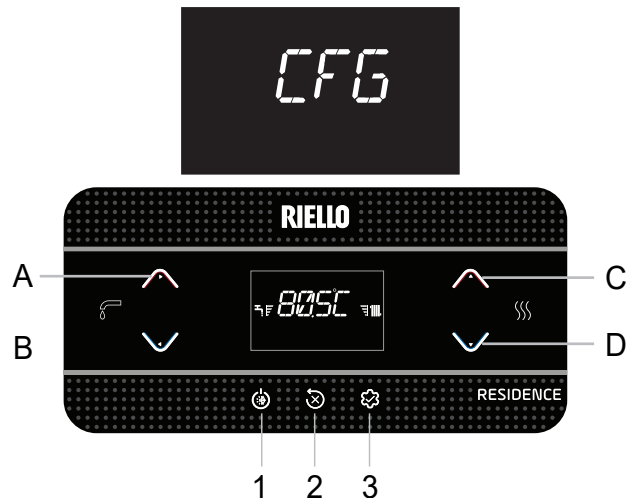

- Power on the boiler electrically and wait for the vent cycle to run (see paragraph "5.3 Venting cycle").
- If it is set to OFF, set SUMMER mode with key 1.
- Generate a DHW request of 5 litres per minute or more. Although there are no limitations on the part of the system, except those foreseen by the ALARMS supervision, however, it is advisable to do the GAC scan with boiler return system water below 15°C or in any case with a temperature compatible with the flow rate of system water towards the boiler.
- Wait until the flame symbol appears on the display.



- Access the parameters (see procedure indicated in chapter 10 "Setting Passwords, Access and Changing Parameters").
- Select menu **P2** using keys **C** or **D** and confirm using key **A**.
- Select parameter P206 using keys **C** or **D** and confirm using key **A**.
Note: the parameter is not available when there is no heat request.
- Set P206 = 1 using key **C** to activate the GAC function.



The display shows GAC flashing and a waiting phase of about 1 minute begins, after which calibration begins. During this phase, the word "GAC" blinks, alternating with fan speed, for a duration of approximately 2-5 minutes.



At this stage, no key must be pressed until the word "END" appears (with P105 = 1 scrolling message → STOP FUNCTION IN PROGRESS), indicating that the procedure has been successfully completed.



If the GAC procedure does not continue, and the value 1 remains displayed even after confirmation (i.e., the procedure does not show the GAC message), it is very likely that the electronic system is performing a combustion check. In this case, wait a few minutes and verify that the system proceeds autonomously. If the situation persists, consider performing a POWER OFF of the boiler and restarting the GAC procedure according to the instructions.



At the end of the function, the parameter automatically returns to 0.



If the GAC procedure is not completed, the system allows the execution of a GAC retry which is indicated on the display with "RTY" and then proceeds by pressing the key **B**.



NOTE: If it is not possible to dissipate heat in the domestic hot water, it is however possible, for high temperature systems, to carry out the GAC on heating request, setting the heating water setpoint at 80.5°C or even better, activating the combustion analysis and subsequently, with flame on, start the GAC.

Once the procedure is finished, press the key **B** 3 times to return to the main screen.

If the procedure is not carried out when it is mandatory to do so, it may lead to a limited operation and the possibility of abnormal combustion control signals occurring.

If a fault occurs during the procedure, or if the heat request is interrupted, the procedure would be prematurely terminated by displaying the fault status or automatically returning to the main screen. In this case, the procedure must be repeated.

5.5 Setting the thermoregulation

Thermoregulation is only available with an outdoor temperature sensor connected and is only active for the HEATING function. THERMOREGULATION is enabled in the following way:

- access the parameter **P4** → P418 = 1.

With P418 = 0 or the outdoor temperature sensor disconnected, the boiler **works at a fixed setpoint**.

The temperature value measured by the outdoor temperature sensor is displayed in the "6.3 INFO menu" at I009.

The thermoregulation algorithm will not use the measured outdoor temperature value directly, but rather a weighted outdoor temperature value, which takes account of the insulation of the building: in well-insulated buildings, external temperature variations have less influence on the room temperature than in less insulated buildings. This value can be displayed in the INFO menu at I010.

REQUEST FROM OT CHRONOTHERMOSTAT

In this case, the delivery setpoint is calculated by the timed thermostat on the basis of the outdoor temperature value, and by the difference between the real ambient temperature and the required ambient temperature.

REQUEST FROM ROOM THERMOSTAT

In this case, the delivery setpoint is calculated by the adjustment board on the basis of the outdoor temperature value, to obtain an estimated ambient temperature of 20°C (reference ambient temperature). There are 2 parameters that are used to calculate the delivery setpoint:

- slope of the compensation curve (KT) - modifiable by technical personnel
- offset to reference ambient temperature - can be modified by the user.

TYPE OF BUILDING (parameter P433)

It is indicative of the frequency with which the value of the calculated outdoor temperature for thermoregulation is updated, a low value for this value will be used for buildings that have little insulation.

REACTIVITY SEXT (parameter P434)

It is an indication of the speed with which variations of the measured outdoor temperature affect the calculated outdoor temperature value for thermoregulation, low values indicate high speeds.

Choice of thermoregulation curve (parameter P419)

The heating thermoregulation curve maintains a theoretical temperature of 20°C in the room for outdoor temperatures between +20°C and -20°C. The choice of the curve depends on the minimum design outdoor temperature (and thus the geographical location) and the design flow temperature (and thereby the type of system) and should be carefully calculated by the installer, according to the following formula:

$$KT = \frac{\text{Project delivery } T_r - T_{\text{shift}}}{20 - \text{min. outdoor project } T_r}$$

Tshift = 30°C standard system
25°C floor installations

If the calculation gives an intermediate value between two bends, you are advised to choose the thermoregulation bend closest to the value obtained.

Example: if the value obtained from the calculation is 1.3, it lies between curve 1 and curve 1.5. Choose the nearest curve, i.e. 1.5. The settable KT values are as follows:

- standard system: 1,0÷3,0
- free-standing system: 0,2÷0,8.

With parameter P419 set the chosen thermoregulation curve:

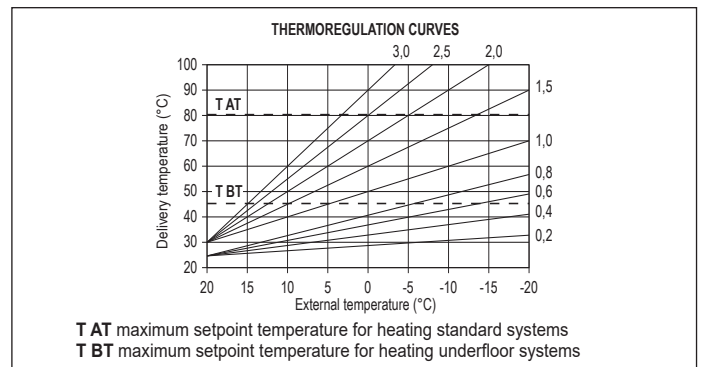

Offset on the reference ambient temperature

In any case, the user can indirectly modify the HEATING setpoint value by inserting an offset on the reference temperature (20°C). This offset may vary from -5 to +5 (offset 0 = 20°C). To correct the offset, refer to paragraph "8.4 Heating setpoint setting with outdoor temperature sensor".

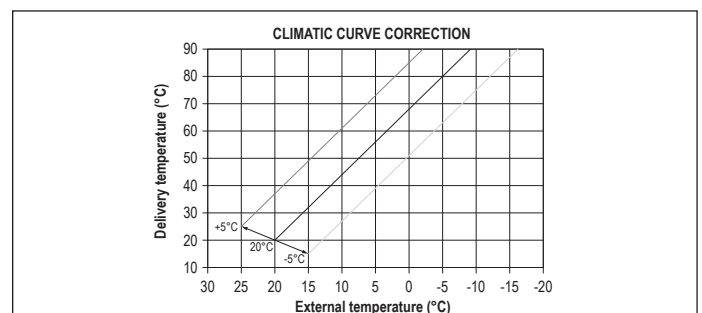

NIGHT COMPENSATION (parameter P420)

If a time programmer is connected to the input ROOM THERMO-STAT, from the parameter P420 night compensation can be enabled.

- set parameter P420 = 1.

In this case, when the CONTACT is CLOSED, the heat request is made by the flow probe on the basis of the outdoor temperature, to obtain a nominal ambient DAY temperature (20°C). The OPENING OF THE CONTACT does not produce a switch-off, but rather a reduction (parallel shift) of the climatic NIGHT curve (16°C).

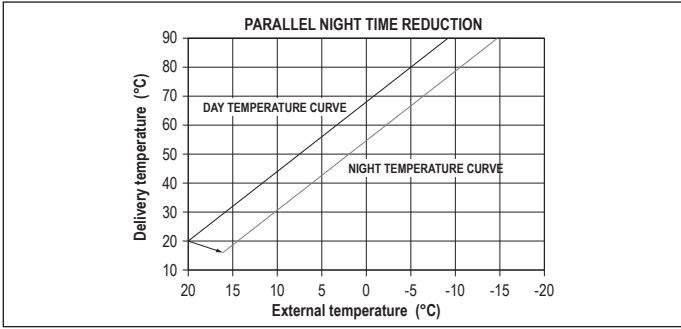

In this case too, the user can indirectly modify the HEATING setpoint value by inserting an offset on the reference DAY temperature (20°C) or NIGHT temperature (16°C). This offset may vary from [-5 to +5]. NIGHT COMPENSATION is not available if OT+ chrono is connected. **To correct the offset, refer to paragraph "8.3 Heating setpoint setting".**

5.6 "DHW comfort" function

The boiler originally includes "DHW COMFORT" FUNCTIONS, which, however, in combination with a DOSSERET, it is preferable that they are not enabled as the TANKS of the DOSSERET fulfill these purposes

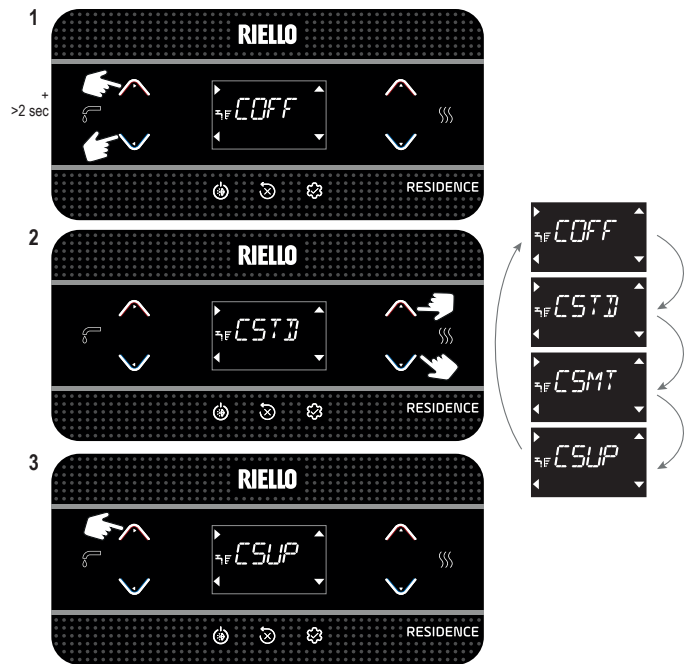

Function	Scrolling message
COFF	COMFORT OFF
CSTD	COMFORT STANDARD
CSMT	COMFORT TOUCH & GO
CSUP	COMFORT SUPERIOR

CSTD (PREHEATING function)

Setting CSTD activates the boiler pre-heating function. This function keeps the water in the domestic hot water exchanger hot, to reduce standby times when a request is made. When the preheating function is enabled, PRH appears on the display (with P105 = 1 scrolling message --> PREHEATING FUNCTION IN PROGRESS). To deactivate the preheating function, set COFF. The function is not active when the boiler is OFF.

CSMT (TOUCH & GO function)

If you do not want PRE-HEATING to be always active and you want hot water immediately ready, it is possible to preheat the domestic hot water just a few moments before taking it. Set CSMT to activate the Touch&Go function. This function allows you, by opening and closing the tap, to start the instantaneous pre-heating that prepare the hot water only for that water take. When the Touch&Go function is enabled T-G appears on the display (with P105 = 1 scrolling message --> TOUCH AND GO FUNCTION IN PROGRESS).

CSUP (SMART preheating function)

When this function is active, the 3-way valve on DHW enables post-circulation at the end of the heating request until one of the following conditions is met:

- ΔT (flow sensor - return) < 2 °C
- Post-circulation duration > 20 sec
- Return temperature > 65 °C.

When the function is enabled PRHS appears on the display (with P105 = 1 scrolling message --> PREHEATING SMART FUNCTION IN PROGRESS).

5.7 Special DHW functions

The boiler originally includes "SPECIAL DHW" FUNCTIONS, which, however, in combination with a DOSSERET, it is preferable that they are not enabled as the TANKS of the DOSSERET fulfill these purposes

Parameter P511 allows special functions to be activated during the DHW modulation phase. These functions improve the performance of the boiler in particularly difficult operating conditions (e.g. particularly high inlet water temperatures, very low flow rates, use in combination with solar storage cylinders).

0	No special function active (default value)
1	Introduction of flow switch/flowmeter start delay (parameter P510 - SERVICE)
2	In the event of a shut-down due to overheating in the DHW area (with withdrawal in progress) the fan is kept at idle to reduce the waiting time for restarting
3	Absolute DHW thermostats
4	Anti-slope smart DHW function
5	All four previous functions active

DHW DELAY function (1)

This function enables a delay, equal to the value set in the parameter P510, for activating the pump and fan when a DHW request arrives.

SMART FAN function (2)

When this function is active, the fan is kept at the minimum (MIN) and is not disabled if the burner is switched off due to DHW overtemperature (with the request still active).

ABSOLUTE THERMOSTATS function (3)

When this function is active, the DHW thermostats for burner ON/OFF switch from the relative value to the absolute one.

ANTI-PENDULATION function (4)

When this function is active, the boiler automatically switches to ABSOLUTE THERMOSTATS mode if the burner is switched off due to DHW overtemperature (with extraction in progress); when the burner is OFF, the fan is kept at the minimum. The thermostats go back to being "CORRELATED" when extraction ends.

5.8 Screed heater function

For a low temperature system, the boiler has a "screed heater" function that can be activated in the following way:

- set the boiler to OFF by pressing the button (function only available in this operating state)

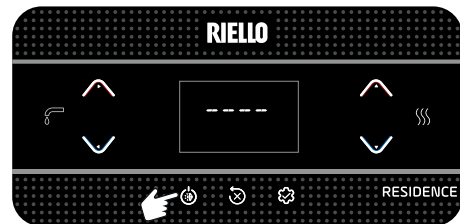

- access technical parameters --> P4 --> P409 = 1 --> confirm; the display shows (with P105 = 1 scrolling message --> SCREED HEATING FUNCTION IN PROGRESS):

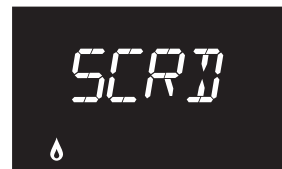

The screed heater function lasts 168 hours (7 days) during which, in the zones configured as low temperature, a heating request is simulated with an initial zone outlet of 20°C, then increased in line with the table below.

By accessing the INFO menu from the main screen of the interface, it is possible to display the value of I001, relating to the number of hours elapsed since the function was activated. Once activated, the function takes priority, if the machine is shut down by disconnecting the power supply, when it is restarted the function picks up from where it was interrupted. The function can be interrupted before its end by switching the boiler to a state other than OFF or by selecting P409= 0 from the menu P4.

DAY	TIME	TEMPERATURE
1	0	20°C
	6	22°C
	12	24°C
2	18	26°C
	0	28°C
3	12	30°C
	0	32°C
4	0	35°C
5	0	35°C
6	0	30°C
7	0	25°C

Note: The temperature and increase values can be set to different values only by qualified personnel, only if strictly necessary. The manufacturer declines all responsibility if the parameters are incorrectly set.

In the INFO menu, line I001 displays the number of hours elapsed since the activation of the function.

5.9 Checks during and after the initial start-up

After starting up, check that the boiler carries out the start-up procedures and subsequent shut-down properly.

- Check the domestic hot water operation by opening a hot water tap in SUMMER mode or WINTER mode.
- Check the full stop of the boiler by turning off the system's main switch.
- After a couple of minutes of continuous operation to be obtained by turning the system's main switch to "on", setting the boiler mode selector to Summer and by keeping open the domestic hot water device, the binders and manufacturing waste evaporate; only subsequently it will be possible to control combustion.

5.10 Combustion check

 The checks of the settings of CO₂ in relation to the reference parameters, indicated in the tables below, must be carried out with the casing closed.

To carry out the combustion analysis, proceed as follows:

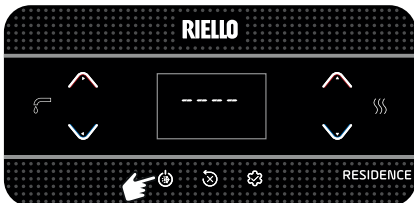
1  

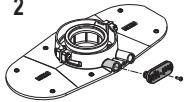
2 

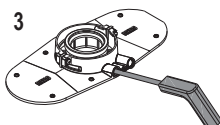
3 

 The probe for the fumes analysis must be inserted until it reaches the stop.



+>2 sec



with P105 = 1 scrolling message --> COMBUSTION ANALYSIS IN PROGRESS



fan speed in CH



- The display will show the defined rpm for 10 sec, along with the rpm icon.
- By setting the maximum value, the boiler will operate at maximum output; by setting the minimum value, the boiler will operate at minimum output.



- Check on the analyser that the values of CO₂ max e min comply with the following tables.

CO ₂ * max		METHANE GAS (G20)	LIQUID GAS (G31)	
	25BIS	8,8	10,0	%
	35BIS	8,8	9,9	%
(*) CO ₂ tolerance = ±1%				

CO ₂ * min		METHANE GAS (G20)	LIQUID GAS (G31)	
	25BIS	8,8	10,0	%
	35BIS	8,8	10,0	%
(*) CO ₂ tolerance = ±1%				

- Check that the values of O₂ (max, nominal and min) related to 20% hydrogen mixture are in accordance with the following.

O ₂ value relative to the 20% hydrogen mixture	Qmax			25BIS	35BIS
		max	%	2,4	2,4
		nominal	%	4,3	4,3
	min	%	6,2	6,2	
	Qmin	max	%	2,4	2,4
		nominal	%	4,3	4,3
min		%	6,2	6,2	

- The COMBUSTION ANALYSIS lasts a maximum of 15 minutes; you can in any case terminate the procedure prematurely by pressing **B**.
- If the system is in low temperature, live, without mixing or thermostatic valves, the COMBUSTION ANALYSIS must be carried out in DHW request mode.

-  COMBUSTION ANALYSIS is terminated prematurely if:
 - the delivery temperature exceeds 95°C; it will ignite again when the temperature falls below 75°C
 - a flame is not detected resulting in an alarm
 - in the event of an alarm.

-  With the OT+ device connected, the combustion control function cannot be activated. To carry out the flue gases analysis, set the value for parameter P803 to 0. Remember to reset the parameter value to reactivate the OT+ connection at the end of the flue gases analysis.

When the check has ended:

- exit function by pressing the key **B**
- remove the analyser probe and close the combustion analysis outlet with the relative plugs and screw
- put the analysis probe adapter (supplied with the boiler) in the documentation bag
- set the boiler to the required operating mode, depending on the season
- regulate the requested temperature values according to needs.

5.11 Adjustments

The boiler has already been adjusted during manufacturing by the manufacturer. However, if it is necessary to carry out the adjustments again (for example after extraordinary maintenance, after replacing the gas valve, after a gas transformation or after replacing the board) follow the procedures described below.

Maximum and minimum power and maximum heating adjustments must be carried out only by qualified personnel:

P306	minimum fan speed
P307	maximum fan speed
P309	maximum fan speed - heating

- power the boiler
- access technical parameters → **P3** → confirm → select the relevant parameter → confirm

- set the desired values with the keys **C** and/or **D**, referring to the following tables
- check that P309= P310.

 The maximum heating fan speed used will be that set in parameter P310.

MAXIMUM NO. FAN ROTATIONS	METHANE GAS (G20)	LIQUID GAS (G31)	
25BIS CH - DHW	6.300 - 7.900	6.100 - 7.600	rpm
35BIS CH - DHW	7.400 - 8.600	7.100 - 8.200	rpm

MINIMUM NO. FAN ROTATIONS	METHANE GAS (G20)	LIQUID GAS (G31)	
25BIS	1.200	1.250	rpm
35BIS	1.300	1.250	rpm

5.12 Gas conversion

The boiler is designed to operate with methane gas (G20) according to the product label. It is possible to convert the boiler to LPG (G31) via the parameter P201.

 Conversion from a family gas to other family gas can be performed easily also when the boiler is installed.

 This operation must be carried out by professionally qualified personnel.

- Access the technical parameters → **P2** → P201 → confirm.
- Use key **C** or **D** to select the desired option:
 - P201 = 1 (NG)
 - P201 = 2 (LPG)
 - P201 = 3
 - P201 = 4

 **Confirm the parameter change with ENTER, then switch off the power supply to the boiler for at least 10 seconds.**

Once the GAS parameter has been modified, a new "GAC" procedure must be carried out (see chap. 5.4). Check that the fan revolutions correspond to what is indicated in **tables 1 and 2**, par. "5.11 Adjustments".

5.13 Gas Supply Pressure Check

To check the gas supply pressure:

- close the gas shut-off valve at the boiler inlet
- loosen the screw on the pressure gauge upstream of the gas valve and connect the hose to the manometer
- open the gas shut-off valve at the boiler inlet
- activate the chimney sweep function
- the correct pressure value for each type of gas is listed in the "Technical Data" table
- after completing the check, end the chimney sweep function
- close the gas shut-off valve at the boiler inlet
- disconnect the hose from the manometer and securely tighten the screw on the pressure gauge upstream of the gas valve
- open the gas shut-off valve at the boiler inlet.

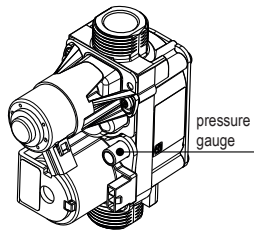

 Failure to tighten the pressure gauge screw may result in combustible gas leakage.



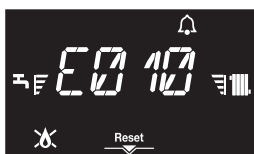

 After any intervention on the gas or air/gas circuit, perform a leak test.

5.14 Signalling and faults

If a fault is present, the icon  blinks at a frequency of 0.5sec ON and 0.5sec OFF, the backlight blinks for 1min at a frequency of 1sec ON and 1sec OFF, after which it switches off, while the bell continues to flash. The error code appears on the 4 digits of the display.



When a fault occurs, the following icons may appear:

-  lights up for a flame alarm (E010)
- RESET lights up for an alarm that needs to be manually reset by the user (e.g. a flame lockout)
-  lights up along with the  icon, apart from flame lockout and water failure faults
-  lights up in the presence of water pressure alarms or warnings, in which case the water pressure value is displayed as an alternative to the fault code every 3 seconds.

Reset function

To restore boiler operation in the event of a fault, the boiler must be operated by pressing the RESET button.

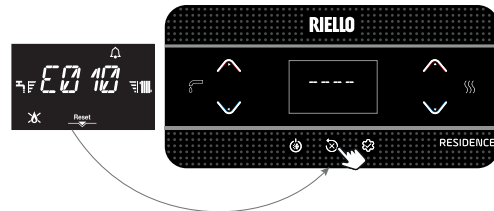

At this point, if the correct operating conditions have been restored, the boiler will restart automatically. Up to a maximum of 5 consecutive attempts to unlock the same alarm from the interface are possible, after which the error code E099 appears on the display.



In this case, the boiler must be disconnected from the electricity supply and then reconnected again, to reactivate operation.

 If the reset attempts do not activate the boiler, contact the Technical Assistance Centre.

Fault E041

Should the pressure value fall below the safety value of 0.3 bar, the boiler displays the fault code E041 for a transitory time of 10 min. When the transitional time has finished, if the fault persists the fault code E040 is displayed.

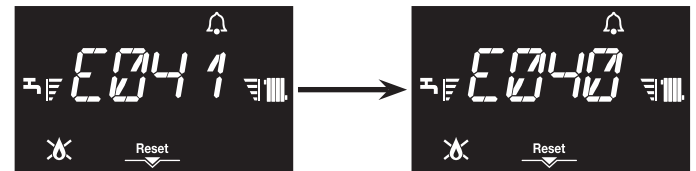

With a boiler in fault E040:

- open the filling tap (**A**) by turning it anticlockwise
- check that the pressure value reaches 1-1.5 bar by means of a hydrometer located under the shelf or by accessing the INFO menu ("6.6 INFO menu", item I018)
- close the filling tap (**A**) making sure you hear the mechanical click.

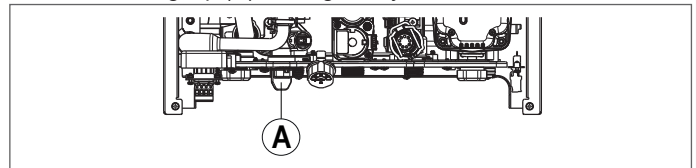

Press  to restore operation.

Once operation is restored, the boiler performs an automatic vent cycle as described in paragraph "4.11 Filling the heating system and removing air".

 If the drop in pressure is very frequent, request the intervention of the Technical Assistance Centre.

Fault E060

The boiler is working normally, but does not guarantee the stability of the DHW temperature that is, however, supplied at a temperature of around 50°C. Intervention of the Technical Assistance Centre is required.

Fault E091

The boiler has an auto-diagnostic system which, based on the total number of hours in certain operating conditions, can signal the need to clean the primary exchanger (alarm code E091).

Once the cleaning operation has been completed, reset to zero the total hour meter with special kit supplied as an accessory following

procedure indicated below:

- access the technical parameters → P3 → P312 → P312 = 1 → confirm.

NOTE: The meter resetting procedure should be carried out after each in-depth cleaning of the primary heat exchanger or if it is replaced.

The fault E091 occurs when the hour counter exceeds 2500 hours; this value can be verified as follows:

- access the INFO menu → I015 to display the value of the flue gas probe hour counter (display/100, example 2500h = 25).

Faults E035-E036: The presence of an alarm notification with code E035 or E036 that requires resetting via the central button may be normal in certain environmental conditions. If the notification is not frequent, perform the alarm reset without the need for technical intervention.

ERROR CODE	ERROR MESSAGE	ALARM DESCRIPTION	
E010	Flame lockout	DEFINITIVE	
E011	Parasitic flame		
E012	Maximum number of flame losses		
E013	Hardware test failed		
E014	Flame detect test failed		
E015	Voltage detect flame test failed		
E020	Limit thermostat		
E021	Gas valve control malfunctioning		
E030	Fan error		
E031	Fan failure mechanical blockage		
E032	Rotor fan failure blocked		
E033	Rotor fan failure damaged		
E034	Chimney obstruction in preventilation		
E035	Blockage obstruction flue gas low power		
E036	Blockage obstruction flue gas high power		
E037	Failed combustion check low power		
E038	Combustion check failed check high power		
E039	Abnormal flame value		
E040 + bar value	Water pressure low... Fill the system		
E042	Water transducer - LWCO error		
E071	CH probe overtemp		
E072	Return - Flow differential		
E075	Valve opening limit reached		
E092	Calibration failed, excessive number of calibrations within the hour		
E088	Reserved alarm		
E093	Calibration failed, too many unsuccessful calibration attempts		
E094	Lambda over limit		
E097	Incorrect Combustion Detected, Incorrect combustion level has been detected		
E098	Incorrect combustion level has been detected		
E099	Reset attempts exhausted		
E041 + bar value	Fill the system		TRANSITORY
E050	Smoke obstruction error low power		
E051	Result of a calibration performed under flame instability/obstruction conditions		
E052	Hardware error out of threshold		
E055	No card fan communication		
E056	No communication microprocessor card		
E060	DHW probe error		
E070	CH probe error		
E071	CH probe overtemp		
E072	Return - Flow differential		
E077	Water thermostat main zone		
E080	Return probe error		
E081	Return probe overtemp		
E082	Flow - Return differential		
E090	Exhaust probe error		
E091	Clean primary ht exchanger		
E095	Calibration failed		
E096	Lambda over limit		
FIL + bar value	Low pressure check the htg system	SIGNAL	
 flashing + bar value	High pressure check the htg system		
COM	Appliance PCB communication lost (more than 30 seconds)	SIGNAL: (the boiler continues to operate but with no display or keys)	
E066	Dosseret communication fail	SIGNAL	
FWER	Warning firmware versions not compatible	SIGNAL: (the boiler continues to operate but with no display or keys)	
CFS	Call for Service	SIGNAL	
SFS	Stop for Service	DEFINITIVE	
OBCD	On board clock damaged	SIGNAL: (the boiler continues to operate but with no display or keys)	

5.15 Replacing the gas valve (P205)

After replacing the gas valve it is necessary to reset the value P1 (see photo) as follows:



- set the boiler to OFF
- access the parameters setting the password in accordance with chapter 10 "Setting Passwords, Access and Changing Parameters"
- using keys **C** or **D** access the parameter **P2** → P205 and confirm using the key **A**
- **using keys C or D enter the second and third digits of the P1 value (i. e. 034 becomes 34) written on the gas valve in the boiler (each gas valve has its own offset P1 value), confirm with key 3**
- disconnect the boiler from the power supply for at least 10 seconds; then reconnect to the mains power supply.

Once the replacement is complete, a new "GAC" procedure must be carried out (see chap. 5.4).

- ⚠ If the gas valve is replaced, also replace the relative sealing gaskets.

To tighten the gas valve ramp nut, apply a torque equal to 25 Nm, limiting the rotation of the valve.

5.16 Replacing the interface

System configuration operations must be carried out by professionally qualified personnel of the Technical Assistance Centre.

If the interface card is replaced, the user may be asked to reset the time and day of the week values at power on (see "5.2 Initial start-up"); also check and reset, if necessary, information on hourly heating and DHW programming (see "8.1 Time band scheduling function (room thermostat)") and the Feeder Bottle function (see "8.12 FEEDER BOTTLE function"); note that no reprogramming of the configuration parameters is necessary, the value of which is retrieved from the regulation and control board in the boiler. Instead, it may be necessary to reset the DHW and/or heating setpoint values.

5.17 Board replacement

If case of the control board is replacement and adjustment procedure, it may be necessary to check the configuration parameters and possibly reconfigure them. Consult the parameter table to identify the board default values, the factory set values and the customized ones. The parameters to necessarily be checked and possibly reset are: P201 • P205 (with boiler in OFF) • P208 • P301 • P302 (SERVICE) • P306 • P307 • P309 • P310.

Disconnect the boiler from the power supply for at least 10 seconds; then reconnect to the mains power supply. Once the replacement is complete, perform a new "GAC" procedure must be carried out (see chap. 5.4).

6 MAINTENANCE AND CLEANING

👁 *Periodic maintenance is an "obligation" required by the law and is essential to the safety, efficiency and duration of the boiler. It allows for the reduction of consumption, polluting emissions and keeping the product safe and reliable over time.*

Boiler maintenance must be carried out at least once a year scheduling it with the Technical Service Centres. Before starting maintenance operations:

- turn off the fuel and water taps of the heating and domestic hot water system.

To ensure product characteristics and efficiency remain intact and to comply with prescriptions of current regulations, it is necessary to render the appliance to systematic checks at regular intervals. For maintenance, follow the instructions in chapter "1 WARNINGS AND SAFETY".

This normally means the following tasks:

- removing any oxidation from the burner
- removing any scale from the heat exchangers
- check the state of deterioration of the electrodes and, if they have deteriorated, replace them together with their seals
- check and general cleaning of exhaust and intake pipes
- checking the external appearance of the boiler
- checking the ignition, switch-off and operation of the appliance, in both DHW mode and heating mode
- checking the seal on the couplings and the gas/water/condensate connection pipes
- checking gas consumption at maximum and minimum output
- if the DHW pressure is less than 3 bar, empty the boiler's DHW circuit and check that the heating circuit pressure is maintained
- checking the integrity of the insulation of electrical cables, particularly in the vicinity of the primary heat exchanger
- checking the gas failure safety device
- checking and cleaning the siphon
- checking the cleanliness of the fan, internal extraction (including the air filter when provided)
- **checking there is water in the drain-trap; if not, fill it.**

⚠ The electronic board and the gas valve do not require a specific check aimed at evaluating aging and deterioration.

⚠ When servicing the boiler, the use of protective clothing is recommended in order to avoid personal injury.

⚠ After maintenance work has been carried out, an analysis of the combustion products must be carried out to check that they are functioning properly.

⚠ Do not clean the appliance or its parts with inflammable substances (e.g. petrol, alcohol, etc.).

⚠ Do not clean panels, painted parts and plastic parts with paint thinner.

⚠ Panel cleaning must be carried out only with soapy water.

Perform a new "GAR" procedure, then remove power for at least 10 seconds, and finally perform a new "GAC" procedure (see par. 5.4), in the following cases:

- modification of intake and exhaust duct
- cleaning of the primary exchanger
- replacement of ignition and flame detection electrodes
- replacement of primary exchanger and/or conveyor.

*Perform a new "GAR" procedure, then remove power for at least 10 seconds, and finally perform a new "GAC" procedure (see par. 5.4) **only if an analysis of combustion products is out of tolerance** in the following cases:*

- burner cleaning
- conveyor cleaning
- fan cleaning
- replacement/cleaning of fan mixer.

Cleaning the primary heat exchanger

- Switch off the electrical supply by turning the main system switch OFF.
- Close the gas shut-off valve.
- Remove the casing as explained in paragraph "4.8 Removing the casing".
- Disconnect the connection cable of the ignition and detection electrodes.
- Disconnect the power cables of the fan.
- Remove the clip securing the gas train from the mixer.
- Loosen the gas train nut.
- Extract the gas train from the mixer and rotate it.
- Remove the 4 nuts that secure the combustion unit.
- Remove the air/gas conveyor assembly including fan and mixer, taking care not to damage the insulation panel and electrode.
- Remove the siphon connecting pipe from the condensate drain fitting of the heat exchanger and connect a temporary collecting pipe. At this point proceed with the heat exchanger cleaning operations.
- Vacuum out any dirt residue inside the heat exchanger, taking care NOT to damage the retarder insulating panel.
- Clean the coils of the heat exchanger with a soft bristled brush.

⚠ DO NOT USE METAL BRUSHES THAT COULD DAMAGE THE COMPONENTS.

- Clean the spaces between the coils using a 0.4 mm thick blade, possibly available in kit form.
- Vacuum away any residue produced by the cleaning intervention.
- Rinse with water, taking care NOT to damage the retarder insulating panel.

⚠ If case of persistent deposits of combustion residues on the surface of the heat exchanger, we recommend to use products from the Total Defence range, taking care NOT to damage the retarder insulation panel.

- Leave it to work for a few minutes.
- Clean the coils of the heat exchanger with a soft bristled brush.

⚠ DO NOT USE METAL BRUSHES THAT COULD DAMAGE THE COMPONENTS.

- Rinse with water, taking care NOT to damage the retarder insulating panel.
- Make sure the retarder insulation panel is undamaged and replace it if necessary following the relative procedure.
- After cleaning, carefully assemble the components again repeating the indications provided above but in the reverse order.
- To tighten the fastening nuts of the air/gas conveyor assembly, use a tightening torque of 6 Nm, following the sequence indicated on the die-cast (1,2,3,4).
- Turn the power and gas feeding to the boiler back on.

⚠ Perform a new "GAR" procedure, then remove power for at least 10 seconds, and finally perform a new "GAC" procedure (see par. 5.4).

⚠ What is indicated is also valid in the case of replacement of the conveyor alone, the exchanger or the conveyor and exchanger assembly.

Cleaning the burner

- Switch off the electrical supply by turning the main system switch OFF.
- Close the gas shut-off valve.
- Remove the casing as explained in paragraph "4.8 Removing the casing".
- Disconnect the connection cable of the ignition and detection electrodes.
- Disconnect the power cables of the fan.
- Remove the clip securing the gas train from the mixer.
- Loosen the gas train nut.
- Extract the gas train from the mixer and rotate it.
- Remove the 4 nuts that secure the combustion unit.
- Remove the air/gas conveyor assembly including the fan and mixer, taking care not to damage the insulating ceramic panel and the electrodes. At this point proceed with the burner cleaning operations.
- Clean the burner with a soft bristle brush, taking care not to damage the insulation panel and electrodes.

⚠ DO NOT USE METAL BRUSHES THAT COULD DAMAGE THE COMPONENTS.

- Check that the burner insulating panel and the sealing gasket are undamaged and replace them if necessary, following the relative procedure.
- After cleaning, carefully assemble the components again repeating the indications provided above but in the reverse order.
- To close the fixing nuts of the air/gas conveyor assembly, use a tightening torque of 6 Nm.
- Turn the power and gas feeding to the boiler back on.

⚠ Carry out an analysis of the combustion products. Only if it returns values outside of tolerance, it is necessary to perform a new "GAR" procedure, then remove power for at least 10 seconds, and finally perform a new "GAC" procedure (see par. 5.4).

⚠ What is indicated is also valid in the case of replacement of the conveyor alone, the exchanger or the conveyor and exchanger assembly.

Replacing the burner insulating panel

- Loosen the screws holding the ignition/detection electrode, and remove it.
- Remove the burner insulating panel by inserting a blade just under the surface.
- Remove any residual fixing adhesive.
- Fit the new burner insulating panel.
- The new insulating panel does not need to be fixed with an adhesive as its geometric form ensures perfect coupling with the heat exchanger flange.

- Refit the ignition and detection electrodes using the screws previously removed and replacing the relevant seal. To tighten the screws, apply a torque of 2.3 Nm.

⚠ Do not perform GAR and/or GAC.

Siphon check and cleaning

- Disconnect the pipes (A - B), unscrew the screw (C), remove the clip (D) and remove the drain-trap.
- Clean the parts of the drain-trap to remove any solid residue.

⚠ Carefully reposition the previously removed components.

⚠ At the end of the cleaning sequence, fill the drain-trap with water (see "5.2 Initial start-up") before re-starting the boiler.

⚠ Do not perform GAR and/or GAC.

⚠ What is indicated also applies in the case of replacing the siphon.

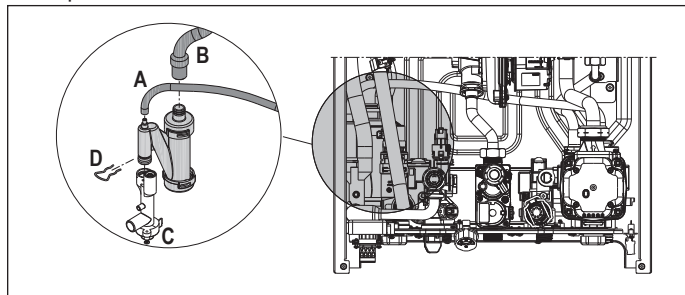

Ignition and detection electrodes

The ignition and detection/ionization sensor electrodes perform an important function in the boiler ignition phase and in maintaining correct combustion; in this regard, during annual maintenance, it is necessary to always check that they are correctly positioned and that the reference dimensions indicated in the figure are strictly respected.

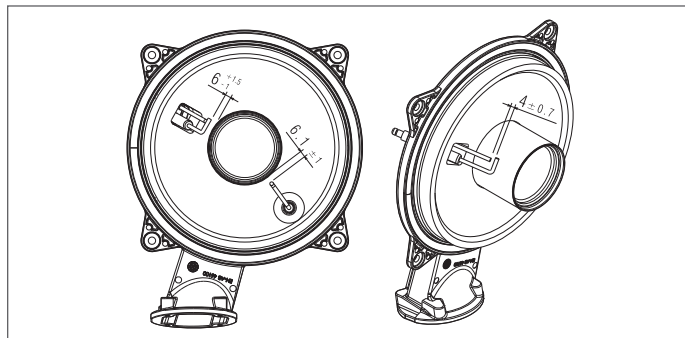

⊘ Do not sand the electrodes. If the electrodes need to be cleaned, dust them using a soft bristle brush.

⚠ In the event of deformation and deterioration of the electrodes outside the tolerances, replace them.

To tighten the screws, apply a torque of 2.3 Nm.

⚠ In order to prevent potential operating anomalies, the ignition and detection/ionisation sensor electrodes must be replaced every 5 years.

⚠ Perform a new "GAR" procedure, then remove power for at least 10 seconds, and finally perform a new "GAC" procedure (see par. 5.4).

Board replacement

- The control and regulation board does not provide a specific procedure for verifying its deterioration. In case of replacement, refer to paragraph "5.17 Board replacement".

Interface board replacement

- The interface board does not provide a specific procedure for verifying its deterioration. In case of replacement, refer to paragraph "5.16 Replacing the interface".

Gas valve replacement

- The gas valve does not provide a specific procedure for verifying its deterioration. In case of replacement, refer to paragraph "5.15 Replacing the gas valve (P205)".
- The gas valve does not provide a specific cleaning procedure.

6.1 Programmable parameters

The following table lists the programmable parameters; USER (always available) and INSTALLER (access with psw 18): set the password following the procedure indicated in chapter 10 "Setting Passwords, Access and Changing Parameters".

For a detailed explanation of the parameters, please refer to the section "6.2 Description of the parameters".

 Some of the information might not be available depending on the access level, machine status or system configuration.

		WHICH PARAMETERS ARE VISIBLE/ACCESSIBLE		
		USER	INSTALLER	SERVICE
LEVEL PASSWORD	USER (always available)	X		
	INSTALLER (psw 18)	X	X	
	SERVICE	X	X	X

USER PARAMETERS 		Value		Password level	Factory setting	Customised values
		Min	Max			
P1	SETTINGS					
	P101	LANGUAGES	0 0: IT • 1: RO • 2: FR • 3: EN • 4: SR • 5: HR • 6: ES • 7: GR • 8: BG • 9: PL • 10: SL	10	USER	0
	P102	TIME			USER	
	P103	TIME PROGRAM			USER	
	P104	UNIT OF MEASURE	0 (metric)	1 (imperial)	USER	0
	P105	SCROLLING	0 (disabled)	1 (enabled)	USER	0
	P106	BUZZER	0	1	USER	1

INSTALLER PARAMETERS		Value		Password level	Factory setting	Customised values
		Min	Max			
P2	COMBUSTION					
	P201	GAS - GAS TYPE	1	4	INSTALLER	1
	P205	d52 - P1 GAS VALVE	20	70	INSTALLER if boiler in OFF	45
	P206	GAC - VALVE CALIBRATION	0	1	INSTALLER only if there is a flame	0
	P208	APL - POWER	0	1	INSTALLER	0: 25 BIS 1: 35 BIS
P3	CONFIGURATION					
	P301	HYDRAULIC CONFIGURATION	0	4	INSTALLER	2*
	P306	MIN FAN SPEED	1000 rpm	3600 rpm	INSTALLER	refer to the technical data table
	P307	MAX FAN SPEED	3700 rpm	10000 rpm	INSTALLER	refer to the technical data table
	P309	MAX FAN SPEED HTG	P306 (MIN FAN SPEED)	P307 (MAX FAN SPEED)	INSTALLER	refer to the technical data table
	P310	RANGE RATED	DO NOT CHANGE			
	P311	CONFIG AUX 1	0	2	INSTALLER	0
	P312	EXHAUST PROBE RESET	0	1	INSTALLER	0
P4	HEATING					
	P405	PUMP CONTROL TYPE	41	100	INSTALLER	85
	P408	OT CASCADE CONTROL	NOT USED ON THIS MODEL			
	P409	SCREED FUNCTION	0	1	INSTALLER if boiler in OFF and LT systems	0
	P410	ANTI CYCLE FUNCTION	0min	30min	INSTALLER	3min
	P411	RESET CH TIMERS	0	1	INSTALLER	0
	P415	MAIN ZONE TYPE	0	1	INSTALLER	0
	P416	MAX CH SET	MIN CH SET	HT: 80°C - LT: 45°C	INSTALLER	HT: 80°C - LT: 45°C
	P417	MIN CH SET	20°C	MAX CH SET	INSTALLER	HT: 40°C - LT: 20°C
	P418	WEATHER COMP ENABLE	0	1	INSTALLER if outdoor temperature sensor present	0
	P419	WEATHER COMP CURVE	HT: 1.0 - LT: 0.2	HT: 3.0 - LT: 0.8	INSTALLER only if P418 = 1	HT 2.0 - LT 0.5
	P420	NIGHT COMPENSATION	0	1		0
	P421	CH CLOCK ENABLE	0	1		0
	P422	MODE SELECTION	0	1		0
	P433	BUILDING TYPE	5	20		5
	P434	OUTDOOR REACTIVITY	0	255	INSTALLER only if P418 = 1	20
	HT = HIGH TEMPERATURE LT = LOW TEMPERATURE					
P5	DHW					
	P508	MIN DHW SET	37°C	49°C	INSTALLER	37°C
	P509	MAX DHW SET	49°C	60°C	INSTALLER	60°C
	P511	DHW ENHANCED FUNCTION	0	5	INSTALLER	0
	P520	DOSSERET ENABLE	0 (disable)	1 (enable)	INSTALLER	0
	P521	DOSSERET TYPE	0 ECO	1 COMFORT	INSTALLER	1

*P301: 0 = HEATING ONLY - 1 = INSTANTANEOUS WITH FLOWSWITCH - 2 = INSTANTANEOUS WITH FLOWMETER - 3 = STORAGE CYLINDER WITH PROBE - 4 = STORAGE CYLINDER WITH THERMOSTAT

If the boiler is combined with the DOSSERET kit (accessory available upon request), the parameters for using the kit must be programmed BEFORE the boiler is used.

SERVICE PARAMETERS		Value		Password level	Factory setting	Customised values
		Min	Max			
P3		CONFIGURATION				
	P302	WATER PRESSURE TRANSDUCER	0	1	SERVICE	1
	P303	AUTO-FILL ENABLE	0	1	SERVICE	0
	P304	BEGIN SYSTEM FILLING	NOT AVAILABLE ON THIS MODEL			
	P305	AIR PURGING CYCLE	0	1	SERVICE	1
P4		HEATING				
	P401	HYST OFF HIGH TEMP	2°C	10°C	SERVICE	5°C
	P402	HYST ON HIGH TEMP	2°C	10°C	SERVICE	5°C
	P403	HYST OFF LOW TEMP	2°C	10°C	SERVICE	3°C
	P404	HYST ON LOW TEMP	2°C	10°C	SERVICE	3°C
P5		DHW				
	P510	DHW DELAY	0 sec	60 sec	SERVICE	0 sec
	P512	CH DELAY POST-DHW	0	1	SERVICE	0
	P513	CH DELAY TIME	1 sec	255 sec	SERVICE	6 sec
P7		SERVICE				
	P701	ENABLE ALARM LOG	0	1	SERVICE	0 (the value automatically switches to 1 after 2 hours of operation)
	P706	CALL SERVICE FUNCTION	0	2	SERVICE	2
	P707	SERVICE EXPIRY	0	255	SERVICE	52
	P708	HIGH EFFICIENCY ENABLE	0	1	SERVICE	0
P8		CONNECTIVITY				
	P801	BUS 485 CONFIG	0	2	SERVICE	0
	P803	OT CONFIG	0	1	SERVICE	1

The boiler with DOSSERET does not allow the use of the T300 device; parameter 801 should be set to 0.

6.2 Description of the parameters

Some of the following functions may not be available depending on the type of machine and the access level.

PARAMETER	DESCRIPTION
P1 - SETTINGS	P101 To set the desired language: 0: IT ● 1: RO ● 2: FR ● 3: EN ● 4: SR ● 5: HR ● 6: ES ● 7: GR ● 8: BG ● 9: PL ● 10: SL
	P102 To set TIME AND DAY
	P103 To set the TIME SCHEDULE
	P104 To change the unit of measurement: 0 = unit of measurement METRIC / 1 = unit of measurement IMPERIAL. The digits are expressed in decimal format (one digit) for values between -9°C and +99°C, they are expressed in integer format for values ≤ -10°C and ≥ 100°C, the display in °F (Fahrenheit) will always be expressed in integer format.
	P105 To set the scrolling text: 0 = disabled / 1 = enabled
	P106 To enable/disable sound indicators: 0 = buzzer OFF / 1 = buzzer ON
P2 - COMBUSTION	P201 This parameter identifies the type of gas: 1=METHANE ● 2=LPG ● 3=PL-NG ● 4=PROPANE AIR (G230).
	P208 This parameter is used to set the boiler output: 0 - 1. For details see "Programmable parameters"
	P205 This parameter is used to reset the P1 value of the gas valve
	P206 This parameter is used to calibrate the gas valve and combustion control system
P3 - CONFIGURATION	P301 To set the type of hydraulic configuration of the boiler: 0 = HEATING ONLY - 1 = INSTANTANEOUS FLOW SWITCH - 2 = INSTANTANEOUS FLOW METER - 3 = STORAGE CYLINDER WITH PROBE - 4 = STORAGE CYLINDER WITH THERMOSTAT Factory setting = 2, do not modify. When replacing the circuit board, ensure that this parameter is set to 2
	P302 To set the water pressure transducer type: 0 = water pressure switch - 1 = pressure transducer Factory setting = 1, do not modify. When replacing the circuit board, make sure this parameter is set to 1.
	P303 To enable the 'semi-automatic filling' function when a pressure transducer and a filling solenoid valve are installed in the boiler. Factory setting = 0, do not modify. When replacing the circuit board, make sure this parameter is set to 0.
	P304 It only appears if P303 = 1. NOT AVAILABLE ON THIS MODEL.
	P305 To disable the vent cycle function. Factory setting = 1, set the parameter to 0 to disable the function.
	P306 To vary the minimum fan speed.
	P307 To vary the maximum fan speed.
	P309 To vary the maximum heating fan speed (can be programmed within the range P306 - P307).
	P310 RANGE RATED adjustment. DO NOT CHANGE.
	P311 To configure the operation of an additional relay (only if BE09 board installed (accessory kit)) to bring a phase (230Vac) to a second heating pump (additional pump) or a zone valve. Factory setting = 0 and can be programmed within the range 0 - 2 with the following meaning: P311= 0 - management depends on the wiring configuration of the BE09 board: jumper cut: additional pump - jumper present: zone valve. P311= 1 - zone valve management P311= 2 - additional pump management
	P312 Allows the operating hours counter to be reset under certain conditions (see "Signalling and faults" fault E091 for details). Factory setting = 0, set to 1 to reset the flue gas probe hour counter after a cleaning operation of the primary heat exchanger. Once the resetting procedure is complete, the parameter automatically returns to the value 0.

P4 - HEATING	P401	For high-temperature systems, this parameter allows you to set the hysteresis value used by the control board to calculate the burner shut-off flow temperature: SHUTDOWN TEMPERATURE = HEATING SETPOINT + P401. Factory value = 5°C, can be changed in the range 2 - 10°C.
	P402	For high-temperature systems, this parameter allows you to set the hysteresis value used by the control board to calculate the burner ignition flow temperature: IGNITION TEMPERATURE = HEATING SETPOINT - P402. Factory value = 5°C, can be changed in the range 2 - 10°C.
	P403	For low-temperature systems, this parameter allows you to set the hysteresis value used by the control board to calculate the burner shut-down flow temperature: SHUTDOWN TEMPERATURE = HEATING SETPOINT+ P403. Factory setting = 3°C, can be changed in the range 2°C- 10°C.
	P404	For low-temperature systems, this parameter allows you to set the hysteresis value used by the control board to calculate the burner ignition flow temperature: IGNITION TEMPERATURE = HEATING SETPOINT - P404. Factory setting = 3°C, can be changed in the range 2°C- 10°C.
	P405	Proportional variable speed pump.
	P408	Allows the boiler to be set up for cascade applications via OT+ signal. Not applicable to this boiler model.
	P409	Allows you to activate the seat-warming function (see section "Screed heater function" for more details). Factory setting = 0, with boiler in OFF. Set to 1 to activate the floor heating function on low-temperature heating zones. The parameter automatically returns to the value 0 once the warming function is finished; it can be interrupted prematurely by setting the value to 0.
	P410	Allows you to change the forced heating off timing, which relates to the delay time introduced for the re-ignition of the burner when the burner is switched off due to reaching the heating temperature. Factory setting = 3 minutes and can be set to a value between 0 min and 20 min.
	P411	Allows you to cancel the function HEATING RESET TIMING and REDUCED HEATING MAXIMUM OUTPUT, during which the fan speed is limited between the minimum value and 60% of the set maximum heating power, with an increase of 10% every 15 minutes. Factory setting = 0, set to 1 to reset timings.
	P415	Allows you to specify the type of zone to be heated, choosing from the following options: 0 = HIGH TEMPERATURE (factory setting) ● 1 = LOW TEMPERATURE
	P416	Lets you specify the maximum heating setpoint value that can be set: range 20°C - 80°C, default 80°C for high temperature systems ● range 20°C - 45°C, default 45°C for low temperature systems. Note: The value of P416 cannot be less than P417.
	P417	With this parameter you have the possibility of specifying the minimum settable heating setpoint: range 20°C - 80.5°C, default 40°C for high temperature systems ● range 20°C - 45°C, default 20°C for low temperature systems Note: The value of P417 cannot be greater than P416.
	P418	Enables thermoregulation when an outdoor temperature sensor is connected to the system. Factory setting = 0, the boiler always operates at fixed point. With parameter 1 and the outdoor temperature sensor connected, the boiler works in thermoregulation mode. With the outdoor temperature sensor disconnected, the boiler works at a fixed setpoint. See "Setting the thermoregulation" for more details on this function.
	P419	Allows you to set the number of the compensation curve used by the boiler when in temperature control. Factory value = 2.0 for high temperature systems and 0.5 for low temperature systems. The parameter can be programmed in the range 1.0 - 3.0 for high temperature systems, 0.2 - 0.8 for low temperature systems. See "Setting the thermoregulation" for more details on this function.
	P420	Activates the 'night compensation' function. Default value = 0, set to 1 to activate the function. See "Setting the thermoregulation" for further information on this function.
	P421	This parameter enables heating time programming. Time programming not enabled = 0 → When the room thermostat contact is closed, the heat request is always fulfilled without time limitation. Time programming enabled = 1 → When the room thermostat contact is closed, the heat request is enabled according to the set time programming.
	P422	This parameter is used to set the mode for switching from manual to automatic heating operation. Default value = 0: switching from manual to automatic time programming must be done by the user by pressing the buttons C+D. Set to 1 to activate the function: switching from manual to automatic time programming takes place automatically at the first time slot change.
	P433	Frequency with which the outdoor temperature value calculated for temperature control is updated; a low value will be used for buildings that have little insulation.
	P434	Reading interval of the outdoor temperature value read by the probe.
P5 - DHW	P501-P507	Functions related to the availability of a storage cylinder. NOT AVAILABLE ON THIS MODEL.
	P508	To set the minimum DHW setpoint.
	P509	To set the maximum DHW setpoint.
	P510	Only visible when parameter P511= 2 or 5. A delay in seconds is introduced on the activation of the pump and fan when there is a DHW heat request.
	P511	Enable special DHW functions: 0 = no function - 1 = introduction of flow switch/flowmeter start delay - 2 = in case of OFF due to overtemperature in DHW (with withdrawal in progress) the fan is kept at minimum speed to reduce the standby time for restart - 3 = absolute DHW thermostats - 4 = anti-slope smart DHW function - 5 = all previous functions active
	P512	Through this value you can enable/disable the DHW post-circulation function with heating start inhibition.
	P513	This value can be used to set the duration of DHW post-circulation when the DHW post-circulation function with heating start inhibition is enabled.
	P520	To enable operation of the boiler in combination with the dosseret
P521	The COMFORT setting causes the boiler to have greater and more frequent storage cylinder reset cycles (TANK). In domestic applications where draw-off cycles are frequent or where the water volume demand is higher. The ECO setting causes the boiler to have a reduced number of storage cylinder reset cycles (TANK). Select this setting if energy savings are to be prioritised.	
P7 - SERVICE	P701	To activate the storage of an alarm history. Default 0; the value automatically changes to 1 after 2 hours of operation. Setting the parameter to the value 0 resets the alarm history I039...I043.
	P706	This parameter allows the boiler to be periodically checked according to a preset operating period in parameter P707. There are three possible settings: 0 = function disabled 1 = function enabled with the following rule: if P707 < 4 the display shows the CFS signal if P707 = 0, the display shows the SFS signal (STOP FOR SERVICE) indicating the permanent inhibition of all heating and DHW heat requests. Not resettable 2 = function enabled: when P707 = 0, the display shows the CFS signal without any operating stop In this condition, in the INFO menu (line I044), the number of days elapsed since the CFS warning appeared is displayed (P707 = 0)  The CFS signal occurs at 10 min intervals for a duration of 1 min, 1 month before the end of the period set in parameter P707.
	P707	Preset operating period for service call (parameter P706)
	P708	Automatic function which is activated at first power on or after 60 days of non-use (electrically powered boiler). In this mode the boiler limits the output for 60 minutes in heating mode to a minimum and the maximum temperature in DHW mode to 55°C. Activating the chimney sweep function temporarily disables this function. 0 = FACTORY VALUE, disable high efficiency mode ● 1 = enable high efficiency mode
P8 - CONNECTIVITY	P801	This parameter is used to enable remote management of the boiler. Three values are available: 0 = FACTORY VALUE. 1 = Management ONLY from boiler interface. 2 = Management from boiler interface and system manager (T300).
	P803	This parameter enables remote boiler management via an OpenTherm device: 0 = OT+ functionality disabled, it is not possible to remotely control the boiler using an OTBus device. By setting this parameter to 0, any OTBus connection is instantaneously interrupted. The icon  and OTB on the display are switched off 1 = FACTORY VALUE. OT+ functionality enabled, an OTBus device can be connected for remote control of the boiler. When connecting an OTBus device to the boiler, the message 'OTB' appears on the display and the icon lights up  .

Note: Full compatibility with third-party OpenTherm devices is not guaranteed.

The boiler with DOSSERET does not allow the use of the T300 device; parameter 801 should be set to 0.

6.3 INFO menu

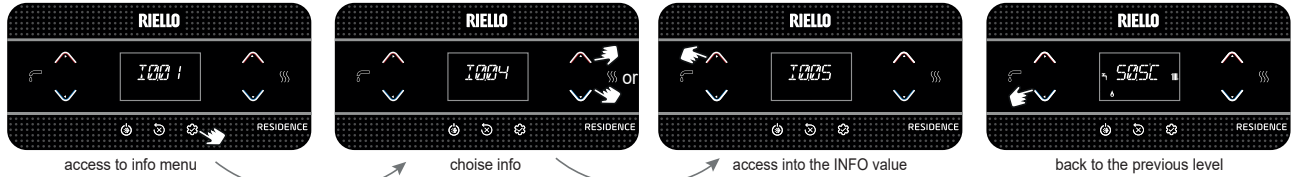





 If no buttons are pressed, the interface automatically exits the INFO menu after 60 sec.

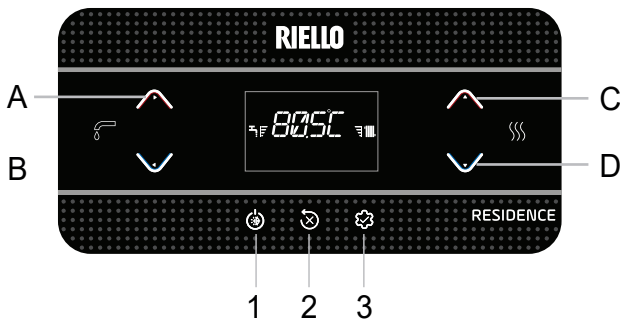



INFO NAME	DESCRIPTION	
1001	Screed heating hours	Number of hours spent with screed heater function (when in operation)
1002	CH probe	Boiler flow sensor value
1003	Return probe	Boiler return temperature sensor value
1004	DHW probe	DHW probe value when instantaneous boiler
1005	DHW set	Boiler DHW setpoint or from OT+ when chrono connected
1008	Exhaust probe	Flue gas probe value
1009	Outdoor temp probe	Instantaneous outdoor temperature sensor value
1010	Filtered outdoor temp	Filtered outdoor temperature sensor value used in the temperature control algorithm to calculate the heating setpoint
1011	DHW flow rate	DHW flow rate
1012	Fan speed	Number of fan rotations (rpm)
1015	Exhaust probe hours	Number of operating hours of the heat exchanger in "condensing mode" (the values are expressed in hundreds of hours, example: 01 = 100h)
1016	Main zone set	Main zone delivery setpoint
1017	OT main zone set	Main zone delivery setpoint from OT+
1018	Water pressure	System pressure
1019	DHW hour	Hours with burner on in DHW mode
1020	CH hour	Hours with burner on in heating mode
1021	DHW modulation	Average modulation percentage value with burner on in DHW mode
1022	CH modulation	Average modulation percentage value with burner on in heating mode
1023	CH supply sensor avg	Average flow sensor values with burner on in heating mode
1024	DHW supply sensor avg	Average flow sensor values with burner on in DHW mode
1025	CH return sensor avg	Average return probe values with burner on in heating mode
1026	DHW return sensor avg	Average return probe values with burner on in DHW mode
1027	Gas valve on cycle	Number of gas valve ON cycles
1029	High efficiency	If it is set to 1, it indicates the need for a drain-trap check for filling
1030	Comfort	DHW comfort
1031	SUN ON	Special functions active for high domestic water inlet temperatures
1033	PCB ID	Type of board connected
1034	PCB FW	Firmware revision of the electronic board
1035	INTERFACE FW	Interface firmware overhaul
1036	Radio signal	Indicates the quality of the WiFi connection
1039	Historical alarm 1 (oldest)	List of the last 5 alarms recorded
1040	Historical alarm 2	
1041	Historical alarm 3	
1042	Historical alarm 4	
1043	Historical alarm 5 (most recent)	
1044	Exchange service	Number of days that have elapsed since the CFS signal was activated (P707 = 0)
1046	Fw comfort development review	Fw comfort development review
1047	Fw safety review	Fw safety review
1048	Fw safety development review	Fw safety development review
1049	Fan Fw review	Fan Fw review

7 CONTROL PANEL



A	Normally used to increase the domestic hot water temperature value, when the arrow is highlighted  it carries out a confirmation function
B	Normally used to decrease the DHW temperature value, but when the arrow  is highlighted it acts as a back/annul button
A+B	Access to the DHW comfort functions (see section "5.6 DHW comfort" function")
C+D	Manual heating time programming, changing status
C	Normally used to increase the heating water temperature value, when highlighted the arrow  allows you to move within the menu P1
D	Normally used to decrease the heating water temperature value, when highlighted the arrow allows  you to move within the menu P1

A+C	Access to the clock setting menu (see section "8 USER INSTRUCTIONS")
B+D	Time band programming
1	Used to modify the boiler operating status (OFF, SUMMER and WINTER)
2	Used to reset the alarm status, or to interrupt the venting cycle
3	Used to access menus INFO (light press) and P1 (press > 2 sec). When the Enter icon appears on the display, this button has an ENTER function and is used to confirm the value set while programming a technical parameter
1+3	Button lock and release
2+3	Used when the boiler is OFF, to activate the flue gas analysis function (CO)

	Indicates connection to a remote device (OTBus or RS485)
	Indicates connection to a WIFI device
	Indicates the presence of an outdoor temperature sensor
	Indicates the activation of special DHW functions, or the presence of a solar thermal management system
	Lights up if an alarm is triggered

	Lights up in the event of a fault together with the icon , excluding flame and water alarms
	Indicates presence of a flame, in the event of a flame lock-out the icon appears
	Flashes with temporary water alarms, steady with definitive alarms
Reset	Lights up in the presence of alarms requiring manual release by the operator
Enter	Lights up when confirmation is required
	When this icon is active, the "confirm" function of button A is active
	When this icon is active, the "back/annul" function of button B is active
	When this icon is active, the user can navigate the menu or increase the value of the selected parameter
	When this icon is active, the user can navigate the menu or decrease the value of the selected parameter
	Lights up if heating mode is active; flashes with a heating request in progress
	Lights up if DHW mode is active; flashes with a DHW request in progress
	Indicate the set point level (1 notch minimum value, 4 notches maximum value)
1 2 3 4 5 6 7	Indicate the days of the week
AUTO ON	Time band programming
MAN ON	Manual time programming ON
MAN OFF	Manual time programming OFF

8 USER INSTRUCTIONS

- Turn the main system switch ON.
- Open the gas tap to allow the flow of fuel.
- With power on the backlight comes on, all icons and segments light up for 1sec and the firmware revision of the control board is displayed for 3sec:



If not set, the programming of the time and day of the week is automatically requested when the device is switched on. The main screen shows the icons , , and and ENTER while 00:00 is displayed with the first two digits flashing at a frequency of 0.5 sec ON, 0.5 sec OFF.

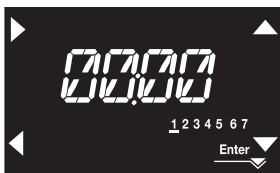

To set the time and day, proceed as follows:

- set the time with the arrows and , then confirm with the key **A**
- set the minutes with the arrows and , then confirm with the key **A**
- set the day of the week using the arrows and . The segment at the selected day blinks, press the MENU button at the icon to confirm the time and day setting. The clock will flash for 4 seconds, then the main screen will be displayed again
- to quit the time programming function without saving the new values, just press the button.

*NOTE: It is also possible to change the TIME and DAY settings at a later date by accessing the SETTINGS menu, parameter P1 → P102, or by pressing the **A+C** for at least 2sec.*

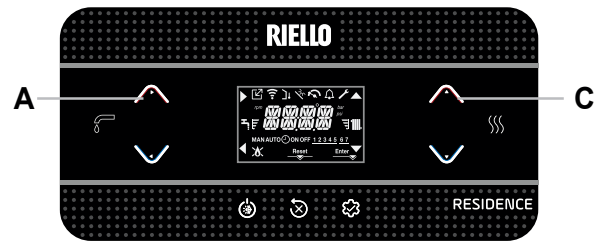

- It then starts the automatic vent cycle, if enabled, lasting 4 min (for details read section "5.3 Venting cycle").
- The interface then shows that it was active in that moment.

Set the room thermostat to the desired temperature or, if the system is equipped with a chronothermostat or time programmer, check that it is 'on' and set.

- Then switch the boiler to WINTER or SUMMER.

8.1 Time band scheduling function (room thermostat)

If the heating system is managed by a room thermostat, and therefore has no time programming, the time programming on the boiler interface can be enabled setting the parameter P4 → P421 = 1.

To activate the automatic heating time programming menu, press the buttons **B+D** for at least 2sec in the main screen.

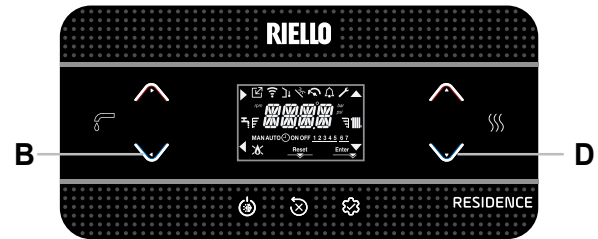

The display appears as follows:

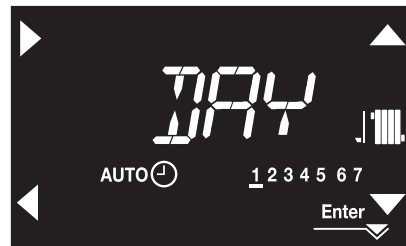

Use the arrows , to select the day or group of days:

- 1-2-3-4-5-6-7 individual day programming
- 1-5 programming Monday to Friday
- 6-7 programming from Saturday to Sunday
- 1-7 whole week's programming

Use the key to confirm your choice and move on to the programming of time slots, use the key to exit the time menu confirming the modifications made.

Use the key to exit programming and cancel the selections made.

Setting Time Bends

- The display shows TIME ON 1, press to set the ON time, use , to modify the time, confirm with .
- The display shows TIME OFF 1, press to set the OFF time, use , to modify the time, confirm with .
- TIME ON 2 appears, then resume programming the time bends until the maximum number of programmable bends (four) is reached, or press to confirm the time bends and move on to the next day's programming.

Outside of these time bends, the room thermostat heat requests are not considered.

The **heating** time bends enabled by default are:

- MONDAY to FRIDAY: 07:30 ÷ 08:30 / 12:00 ÷ 13:30 / 18:00 ÷ 22:30
- SATURDAY to SUNDAY: 08:00 ÷ 22:30.

When heating time programming is enabled, pressing the buttons **C+D** allows you to switch between AUTO and MAN ON or MAN OFF time programming.

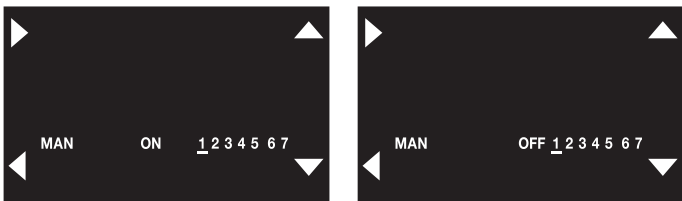
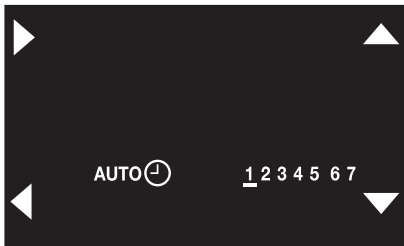
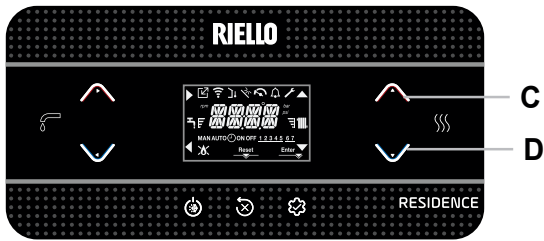

8.2 Operating status

- By pressing button 1, the type of operation changes cyclically from OFF - SUMMER - WINTER and finally OFF again.
- In OFF state, the water pressure value appears on the display every 2 seconds.
- If no key is pressed for 60 seconds, the interface goes into stand-by mode. Normally the pressure value is displayed, unless there has been a request for heat (in which case the temperature is displayed). If the time is set, the pressure value is replaced by the current time.

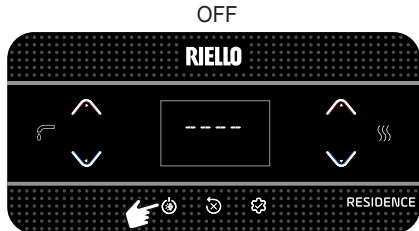

WINTER MODE

The boiler activates the heating and DHW function, the presence of the icon indicates a heat request and burner ignition.



SUMMER MODE

The boiler activates the traditional DHW-only function.



8.3 Heating setpoint setting

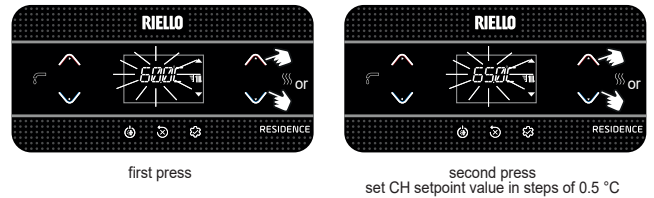

If no key is pressed for 5 sec., the set value is taken as the new heating setpoint.

8.4 Heating setpoint setting with outdoor temperature sensor

With the outdoor temperature sensor connected (optional) and temperature control enabled (parameter P4 → P418=1), the delivery temperature value is chosen automatically by the system, which quickly adjusts the room temperature according to changes in the outdoor temperature.

Modification of the heating setpoint



The setpoint correction is in the range (-5 - +5 °C). With parameter P4 → P418=0 the boiler works at a fixed point.

8.5 DHW setpoint adjustment



If no key is pressed for 5 sec., the set value is taken as the new DHW setpoint.

8.6 Safety stop

If faults arise in ignition or operations, the boiler makes a "SAFETY STOP": The display shows the error code encountered. For details see "5.14 Signalling and faults".

Reset function

Contact the Technical Assistance Centre if unlocking attempts fail to reactivate regular operation.



8.7 Temporary shut-down

In the event of temporary absences (weekends, short breaks, etc.) set the status of the boiler to OFF.

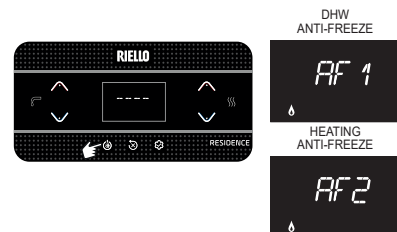

While the electrical supply and the fuel supply remain active, the system is protected by the following functions:

- heating anti-freeze:** the function starts if the temperature detected by the flow sensor falls below 5°C. In this phase a heat request is generated with burner ignition at minimum output, which is maintained until the water delivery temperature reaches 35°C; the display shows AF2 (with P105 = 1 scrolling message --> AF2 CH FROST PROTECT FUNCTION IN PROGRESS)

- **DHW anti-freeze:** the function starts if the temperature detected by the DHW probe falls below 5°C. In this phase a heat request is generated with burner ignition at minimum output, which is maintained until the water delivery temperature reaches 55°C; the display shows AF1 (with P105 = 1 scrolling message --> AF1 DHW FROST PROTECT FUNCTION IN PROGRESS)
- **anti-lockout circulator:** the circulator is activated every 24 hours for a stop period of 30 seconds.

8.8 Switching off for long periods

If the boiler is not used for a long period of time, the following operations must be carried out:

- set the system to OFF
- set the main system switch to "off"
- turn off the fuel and water taps of the heating and domestic hot water system.

In this case, the anti-freeze and anti-locking systems are deactivated. Drain the heating and domestic water system if there is any risk of freezing.

8.9 Keypad lockout function

To lock the keys

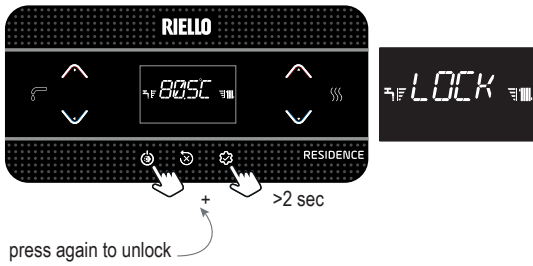

In the presence of a fault, key 2 remains active to allow the alarm to be reset.

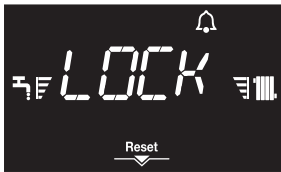

8.10 Alarm history

The alarm history is activated with parameter P7 → P701=1 (SERVICE).

Alarms can be viewed as follow:

- INFO menu (I039 to I043), in chronological order, from newest to oldest, up to a maximum of 5.

If an alarm occurs several times consecutively, it is saved only once. To reset the alarm, follow the indications given in paragraph "8.6 Safety stop".

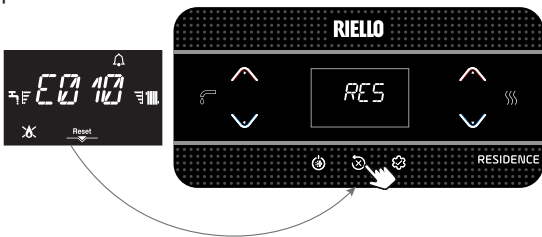

8.11 Connectivity menu

Remote management of the boiler can be done via:

- **Wi-Fi key (Not available)**

It is also possible to activate remote management via an **OpenTherm chronothermostat**.

Note: Full compatibility with third-party OpenTherm devices is not guaranteed.

Note: the T100 remote control cannot be connected to the boiler if the system is hybrid (presence of a heat pump).

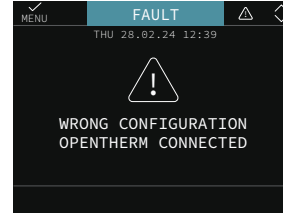

8.12 FEEDER BOTTLE function





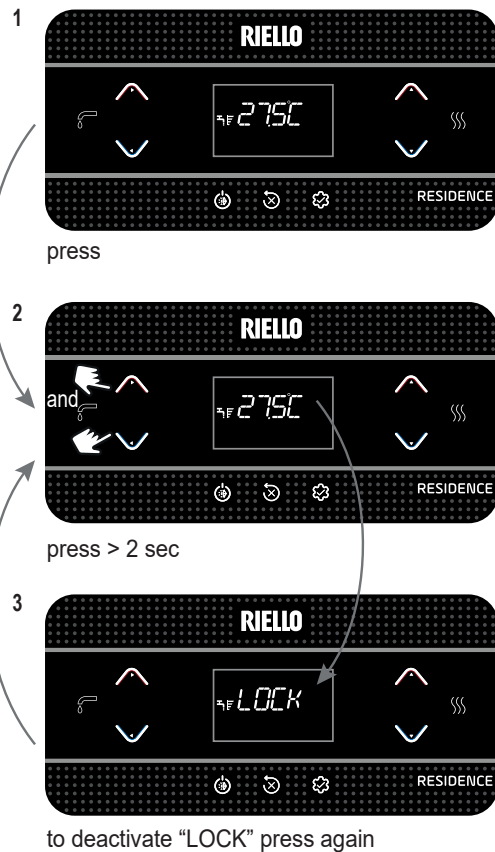









The feeder bottle function blocks the DHW setpoint value to prevent it from being accidentally modified.

To activate this function, from the DHW set point screen:



În cazul combinării cazanului cu kitul DOSSERET, este necesară programarea adecvată a parametrului P520 (vezi paragraful "6.1 Parametri programabili")

1 AVERTISMENTE ȘI MĂSURI DE SIGURANȚĂ











-  Centralele produse în fabricile noastre sunt realizate acordând o atenție deosebită inclusiv componentelor individuale, pentru a proteja atât utilizatorul, cât și persoana responsabilă de instalare împotriva unor eventuale accidente. Prin urmare, se recomandă personalului calificat ca, după fiecare intervenție asupra produsului, să acorde o atenție deosebită conexiunilor electrice, în special în ceea ce privește partea neizolată a conductorilor, care nu trebuie să iasă în niciun caz din tabloul de conexiuni, evitând astfel contactul posibil cu părțile neizolate ale conductorului în cauză.
-  Prezentul manual face parte integrantă din produs: asigurați-vă că manualul se află întotdeauna în dotarea centralei, inclusiv în cazul transferului către un alt proprietar sau utilizator sau dacă este transferată la o altă instalație. În cazul deteriorării sau pierderii manualului, solicitați un alt exemplar echipei de asistență tehnică de la nivel local.
-  Aparatul poate fi utilizat de copii care au împlinit 8 ani și de persoane cu capacități fizice, senzoriale sau mentale reduse, sau fără experiența sau cunoștințele necesare, doar dacă sunt supravegheate direct sau după ce și-au însușit instrucțiunile corespunzătoare utilizării echipamentului în siguranță și înțelegerii pericolelor pe care le presupun. Copiii nu trebuie să se joace cu aparatul. Curățarea și întreținerea care intră în sarcina utilizatorului nu trebuie să fie efectuate de către copii nesupravegheați.
-  Cazanul este potrivit pentru utilizare cu gaze combustibile din grupa H și/sau grup E și cu amestecuri de gaz natural și hidrogen până la 20% în volum.
-  Instalarea centralei și orice altă intervenție de asistență și întreținere trebuie să fie efectuate de personal calificat conform reglementărilor în vigoare și în conformitate cu normele UNI 7129-7131, cu actualizările ulterioare.
-  Întreținerea centralei trebuie să fie efectuată cel puțin o dată pe an, programând-o din timp la echipa de asistență tehnică.
-  Instalatorul trebuie să instruiască utilizatorul cu privire la funcționarea aparatului și la normele esențiale în materie de siguranță.
-  Instalatorul trebuie să respecte avertismentele prezentate în acest manual.
-  Această centrală trebuie să fie utilizată conform destinației pentru care a fost fabricată în mod expres. Este exclusă orice responsabilitate contractuală și extracontractuală a producătorului pentru daunele cauzate persoanelor, animalelor sau lucrurilor, ca urmare a unor erori de instalare, reglare, întreținere sau a utilizării necorespunzătoare.
-  După îndepărtarea ambalajului, asigurați-vă că este complet conținutul. În cazul în care conținutul nu corespunde, adresați-vă distribuitorului de la care ați achiziționat centrala.
-  Evacuarea supapei de siguranță a aparatului trebuie să fie conectată la un sistem de colectare și evacuare adecvat. Producătorul aparatului nu este responsabil pentru eventualele pagube cauzate de intervenția supapei de siguranță.
-  Eliminați materialele de ambalare în recipiente adecvate, la centre de colectare corespunzătoare.
-  Deșeurile trebuie să fie eliminate fără riscuri pentru sănătatea umană și fără a recurge la proceduri sau la metode care ar putea cauza daune de mediu.
-  La sfârșitul ciclului de viață, produsul nu trebuie să fie eliminat ca un deșeu solid municipal, ci trebuie să fie încredințat unui punct de colectare diferențiată a deșeurilor.

- periodic trebuie să se asigure că presiunea de lucru a instalației hidraulice este mai mare de 1 bar. În cazul în care este necesar, asigurați restabilirea presiunii deschizând robinetul de umplere (**secțiunea 9 - consultați "Disponerea centralei"**)
- Așteptați ca presiunea să crească: pe afișajul centralei, verificați dacă valoarea ajunge la 1-1,5 bar; Apoi închideți la loc robinetul de umplere (**secțiunea 9 - consultați "Disponerea centralei"**).

Dacă nu utilizați centrala pentru o perioadă îndelungată de timp, este recomandat să efectuați următoarele operațiuni:

- Poziționați echipamentul în starea de DEZACTIVARE și aduceți întrerupătorul general al instalației în poziția „oprit”
- Închideți robinetele de carburant și de apă ale instalației de încălzire și de apă menajeră
- goliți instalația termică și de apă menajeră, dacă există riscul de îngheț.

Pentru siguranța dumneavoastră, trebuie să rețineți că:

-  Este interzisă acționarea dispozitivelor sau a aparatelor electrice precum întrerupătoare, electrocasnice etc. dacă se simte miros de carburant sau de gaze nearse. În acest caz:
 - aerisiți încăperea deschizând ușile și ferestrele;
 - închideți dispozitivul de interceptare a carburantului;
 - solicitați intervenția rapidă a echipei de asistență tehnică sau a personalului calificat.
-  Este interzisă atingerea aparatului dacă sunteți cu picioarele goale și aveți părți ale corpului ude.
-  Este interzisă orice operațiune tehnică sau de curățare înainte de decuplarea aparatului de la rețeaua de alimentare electrică, aducând centrala în starea „DEZACTIVAT” și întrerupătorul general al aparatului în poziția „oprit”.
-  Este interzisă modificarea dispozitivelor de siguranță sau de reglare fără acordul și indicațiile producătorului aparatului.
-  Este interzis să trageți, să desprindeți, să răsuciți cablurile electrice care ies din aparat, chiar dacă acesta este deconectat de la rețeaua de alimentare cu energie electrică.
-  Evitați acoperirea sau reducerea deschiderilor de ventilație a încăperii din punctul de vedere al dimensiunilor.
-  Nu lăsați recipiente și substanțe inflamabile în încăperea în care este instalat aparatul.
-  Este interzis să eliberați în mediul înconjurător sau să lăsați la îndemâna copiilor materialul ambalajului, întrucât poate fi o potențială sursă de pericol. Acesta trebuie eliminat conform prevederilor reglementărilor în vigoare.
-  Este interzisă blocarea scurgerii condensului. Conducta de evacuare a condensului trebuie să fie îndreptată spre conducta de evacuare evitând formarea unor sifoane ulterioare.
-  Nu interveniți sub nicio formă asupra supapei de gaz.
-  Este interzisă orice intervenție asupra elementelor sigilate.

2 DESCRIERE

Cazanele **RESIDENCE AQUA HM BIS** au un nou sistem de control al arderii ACC (control activ al arderii). Acest sistem de control inovator, dezvoltat de Riello, garantează funcționalitate, eficiență și emisii scăzute în toate circumstanțele. Sistemul ACC folosește un senzor de ionizare scufundat în flacăra arzătorului care, prin informațiile sale, permite tabloului de comandă să acționeze asupra supapei de gaz care reglează combustibilul. Acest sistem de control sofisticat permite autoreglarea arderii, eliminând necesitatea calibrării inițiale a supapei de gaz. Sistemul ACC este capabil să adapteze cazanul pentru a funcționa cu diferite compoziții de gaz, diferite lungimi de conducte și diferite altitudini (în limitele de proiectare așteptate). De asemenea, sistemul ACC este capabil să efectueze o autodiagnosticare care blochează arzătorul înainte de a depăși praguri de emisie mai mari decât limitele admise de reglementări.

În timpul instalării, utilizatorul trebuie să fie informat că:

- în cazul unor pierderi accidentale de apă, trebuie întreruptă alimentarea cu apă și informată imediat echipa de asistență tehnică

3 PARAMETRI TEHNICI

DESCRIERE		UM	25 HM BIS		35 HM BIS	
			G20	G31	G20	G31
Încălzire	Capacitate termică nominală	kW-kcal/h	20,00-17.200		30,00-25.800	
	Putere termică nominală (80°/60°)	kW-kcal/h	19,53-16.799		29,28-25.181	
	Putere termică nominală (50°/30°)	kW-kcal/h	21,31-18.323		31,75-27.302	
	Capacitate termică redusă	kW-kcal/h	2,50-2.150	-	3,50-3.010	-
	Putere termică redusă (80°/60°)	kW-kcal/h	2,34-2.009	-	3,36-2.891	-
	Putere termică redusă (50°/30°)	kW-kcal/h	2,57-2.213	-	3,71-3.191	-
ACM	Capacitate termică nominală	kW-kcal/h	25,00-21.500 I2Y20: 24,00-20.640		34,90-30.014	
	Putere termică nominală (*)	kW-kcal/h	25,00-21.500		34,90-30.014	
	Capacitate termică redusă	kW-kcal/h	2,50-2.150	-	3,50-3.010	-
	Putere termică redusă (*)	kW-kcal/h	2,50-2.150	-	3,50-3.010	-
Randament util Pn max - Pn min (80°/60°)	%	97,7-93,5		97,6-96,0		
Randament la ardere	%	98,0		97,8		
Randament util Pn max - Pn min (50°/30°)	%	106,5-102,9		105,8-106,0		
Eficiență utilă la 30% Pn max (30° revenire)	%	109,7		109,7		
Putere electrică totală (putere max ÎNC - ACM)	W	73-87		87-110		
Putere electrică circulator (1.000 l/h)	W	43		43		
Categorie • Țara de destinație			I12HY203P • RO		I12HY203P • RO	
Tensiune de alimentare	V-Hz	230-50		230-50		
Pierderi la oprire	IP	X5D		X5D		
Heat loss on shut-down	W	30		35		
Pierderi la coș cu arzătorul stins - aprins	%	0,09-2,04		0,07-2,17		
Exercițiul pe circuitul de încălzire						
Presiune maximă	bari	3		3		
Presiune minimă pentru funcționarea standard	bari	0,25+0,45		0,25+0,45		
Temperatura maximă	°C	90		90		
Câmp de selectare a temperaturii H2O pentru încălzire	°C	40-80 (înalt) 20-45 (scăzut)		40-80 (înalt) 20-45 (scăzut)		
Pompă: prevalență maximă disponibilă pentru instalație la o capacitate de	mbari	450		450		
Vas de expansiune cu membrană	l/h	1.000		1.000		
Preîncărcare vas de expansiune (încălzire)	l	9		9		
	bari	1		1		
Exercițiul pe circuitul de ACM						
Presiune maximă	bari	8		8		
Presiune minimă	bari	0,5		0,5		
Cantitate de apă caldă	cu Δt 25° C	l/min		14,3		
	cu Δt 30° C	l/min		11,9		
	cu Δt 35° C	l/min		10,2		
Debit minim apă caldă menajeră	l/min	2		2		
Câmp de selectare a temperaturii H2O pentru ACM	°C	37-60		37-60		
Regulator de flux	l/min	14		14		
Presiune gaz						
Presiune nominală gaz natural (G20 - I2H)	mbari	20	-	-	20	
Presiune nominală MTN-H (G20.2 - I2Y20)	mbari	-	20	-	20	
Presiune nominală GPL (G31-I3P)	mbari	-	-	30	30	
Debite încălzire			G20	G31	G20	
Debit aer	Nm³/h	24,804		24,819		
Debit gaze arse	Nm³/h	26,811		26,370		
Debit masic gaze arse (max-min)	g/s	9,267-1,158		9,297-1,162		
Debite ACM			G20	G31	G20	
Debit aer	Nm³/h	31,005		31,024		
Debit gaze arse	Nm³/h	33,513		32,963		
Debit masic gaze arse (max-min)	g/s	11,584-1,158		11,621-1,162		
Performanțe ventilator						
Prevalență reziduală conducte concentrice 0,85 m	Pa	60		60		
Prevalență reziduală conducte separate 0,5 m	Pa	180		195		
Prevalență reziduală centrală fără tevi	Pa	186		199		
Nox		clasă 6		clasă 6		
Valoare maximă emisii admisă (**)			G20	G31	G20	
Qn-Qr	CO (0% O2) inferior de	p.p.m.	230-15		250-20	
	CO2 (***)	%	8,8-8,8		10,0-10,0	
	NOx (0% O2) inferior de	p.p.m.	40-30		50-50	
	T gaze arse	°C	79-60		78-60	
Valoarea O2 asociată combinației 20% hidrogen	Qmax	max	%		2,4	
		nominal	%		4,3	
		min	%		6,2	
	Qmin	max	%		2,4	
		nominal	%		4,3	
		min	%		6,2	

(*) Valoarea medie între diferite condiții de funcționare în modul de apă menajeră

(**) Verificare efectuată cu țevă concentrică Ø 60-100 lungime 0,85 m. - la încălzire, temperaturile apei 80-60°C - valori măsurate cu carcasa complet închisă. În funcție de tipul sistemului de evacuare, valorile CO pot diferi de cele declarate. Dacă nivelul depășește 500 ppm, solicitați urgent intervenția Serviciului de Asistență Tehnică

(***) Toleranță CO2= ±1%

Datele menționate nu trebuie folosite pentru a certifica instalația; pentru certificare trebuie preluate datele din „Broșură instalație”, măsurate la prima punere în funcțiune.

VALORI REFERITOARE LA PERFORMANȚA APEI CALDE MENAJERE CU FIERBĂTOR ÎN CAZUL INSTALĂRII SETULUI DOSSERET (DISPONIBIL LA CERERE)

Descriere		25 HM BIS	35 HM BIS
Tip fierbător	Ø	Inox	Inox
Disponere fierbător	Ø	Vertical	Vertical
Disponere schimbător	Ø	parte exterioară cu plăci	parte exterioară cu plăci
Vnom, conținutul real de apă sanitară	l	31	31
Câmp de selectare a temperaturii apei menajere	°C	37-60	37-60
Cantitatea de apă preluată în 10 minute cu un Dt minim de 30°C	l	119	167
Presiune maximă de funcționare încălzitor	bar	10	10
Vbu, volum de acumulare non-solar	l	31	31
Debit specific conform EN13203-1	l/min	14,3	18,1

PARAMETRI	UM	GAZ METAN (G20)		GPL (G31)	
Indice Wobbe inferior (la 15 °C-1013 mbari)	MJ/m³S	45,67		70,69	
Putere calorifică inferioară	MJ/m³S	34,02		88	
Presiune nominală de alimentare	mbari (mm H2O)	20 (203,9)		30 (305,9)	
Presiune minimă de alimentare	mbari (mm H2O)	13 (132,6)		-	
		25 HM BIS	35 HM BIS	25 HM BIS	35 HM BIS
Arzător: diametru/lungime	mm	70/80,5	70/95	70/80,5	70/95
Capacitate maximă gaz pentru încălzire	Sm³/h	2,12	3,17	-	-
	kg/h	-	-	1,55	2,33
Capacitate maximă gaz apă caldă menajeră	Sm³/h	2,64	3,69	-	-
	kg/h	-	-	1,94	2,71
Capacitate minimă gaz pentru încălzire	Sm³/h	0,26	0,37	-	-
	kg/h	-	-	0,19	0,27
Capacitate minimă gaz pentru apă menajeră	Sm³/h	0,26	0,37	-	-
	kg/h	-	-	0,19	0,27
Număr maxim de rotații ventilator pentru încălzire	rotatii/min	6.300	7.400	6.100	7.100
Număr maxim de rotații ventilator pentru ACM	rotatii/min	7.900	8.600	7.600	8.200
Număr minim de rotații ventilator (încălzire - ACM)	rotatii/min	1.200	1.300	1.250	1.250
Număr maxim de rotații ventilator (încălzire) în config. C(10)3 (Ø80/125 • Ø80-80)	rotatii/min	6.500	7.600	-	-
Număr maxim de rotații ventilator (ACM) în config. C(10)3 (Ø80/125 • Ø80-80)	rotatii/min	8.100	8.600	-	-
Număr minim de rotații ventilator (încălzire - ACM) în config. C(10)3 (Ø80/125 • Ø80-80)	rotatii/min	2.100	2.200	-	-

NOTĂ: în primele 10 ore de funcționare a arzătorului, minimul nu va coborî niciodată sub 1400 rpm (atât pentru 25, cât și pentru 35 kW); 1600 rpm dacă GPL.

Descriere	Tip de centrală RESIDENCE AQUA HM BIS					
	25 BIS	35 BIS	25 BIS	35 BIS	25 BIS	35 BIS
	C4		C6		C8	
Date tehnice pentru instalații tipice:						
Temperatura produselor de ardere @ Putere termică nominală (la 80/60° C) - [°C]	63	63,8	63,5	63,9	49,7	56,3
Debit masic [kg/h] @ Putere termică nominală [kW]	2,759	3,823	2,743	4,089	2,833	3,944
Putere termică nominală [kW]	25,8	35,67	25,55	38,4	26,46	36,82
Supratemperatura produselor de ardere [°C]	115					
Temperatura gazelor de ardere la puterea termică minimă [°C]	35,6	39,5	57,6	60,1	35,8	37,4
Debit masic [kg/h] @ Putere termică minimă [kW]	0,545	0,694	0,305	0,422	1,036	1,187
Putere termică minimă [kW]	5,14	6,52	2,87	4	9,74	11,1
Conținut CO2 @ Putere termică nominală [%]	8,42	8,56	10,00	10,40	5,62	5,92
CO2 la putere termică minimă [%]	3,12	3,04	9,08	9,26	2,65	2,56
Pierdere de presiune minimă admisă (la alimentarea cu aer și conducta pentru gaze arse) [Pa]	4,4	8,3	-	-	-	-
Pierdere de presiune maximă admisă (la alimentarea cu aer și conducta pentru gaze arse) [Pa]	180	195	-	-	-	-
Diferența de presiune maximă admisă între intrarea aerului de ardere și ieșirea gazelor arse (incluzând presiunea vântului) [Pa]	-	-	4,4	8,3	-	-
Temperatura maximă admisă a aerului de ardere [°C]	-	-	45	45	-	-
	C9					
	25 BIS - 35 BIS					
Diametrul minim util al coșului de fum/compartiment tehnic vertical pentru alimentarea cu aer de ardere [mm]	240					

Observații

- C1:** pentru instalarea terminalelor pe perete și pe plafon, consultați instrucțiunile specifice incluse în kituri terminalele ies din circuite separate de ardere și de alimentare cu aer într-un pătrat de
- C3:** terminalele circuitelor separate de ardere și de alimentare cu aer trebuie să se încadreze într-un pătrat de 50 cm și distanța dintre planurile celor două orificii trebuie să fie mai mică de 50 cm
- C4:** centralele din această configurație cu conductele asociate de conexiune sunt adecvate pentru conexiune cu un singur coș cu tiraj natural nu este permis fluxul de condens în echipament
- C5:** terminalele pentru alimentarea cu aer de ardere și pentru evacuarea produselor de ardere nu trebuie să fie instalate pe pereții opuși ai construcției
- C6:** este permis fluxul de condens în echipament
rata de recirculare maximă admisă de 10% în condiții de vânt
terminalele pentru alimentarea cu aer de ardere și pentru evacuarea produselor de ardere nu trebuie să fie instalate pe pereții opuși ai construcției
aparatură nu trebuie conectat la un coș de fum comun (adică, mai multe aparate pe un coș de fum partajat) care funcționează sub presiune pozitivă.
- !** Acest tip de configurație nu este permis în anumite țări - consultați normele locale în vigoare
- C8:** nu este permis fluxul de condens în echipament

3.1 Date Erp

Parametru	Simbol	25 HM BIS	35 HM BIS	Unit
Clasa de randament energetic sezonier aferent încălzirii incintelor	-	A	A	-
Clasa de randament energetic aferent încălzirii apei	-	A	A	-
Putere nominală	Pnominal	20	29	kW
Randamentul energetic sezonier aferent încălzirii incintelor	η_s	94	94	%
Puterea termică utilă				
La puterea termică nominală și regim de temperatură ridicată (*)	P4	19,5	29,3	kW
La 30% din puterea termică nominală și regim de temperatură scăzută (**)	P1	6,6	9,9	kW
Randament util				
La puterea termică nominală și regim de temperatură ridicată (*)	η_4	87,9	87,9	%
La 30% din puterea termică nominală și regim de temperatură scăzută (**)	η_1	98,8	98,8	%
Consumuri electrice auxiliare				
În sarcină totală	elmax	30,0	44,3	W
În sarcină parțială	elmin	12,2	13,6	W
În mod standby	PSB	3,0	3,0	W
Alți parametri				
Pierderi termice în mod standby	Pstby	30,0	35,0	W
Consum de energie electrică de la flacăra pilot	Pign	-	-	W
Consumul anual de energie	QHE	60	90	GJ
Nivelul de putere acustică, în interior	LWA	48	47	dB
Emisii de oxizi de azot	NOx	22	35	mg/kWh
Pentru instalațiile combinate de încălzire				
Profilul de sarcină declarat		XL	XL	
Randamentul energetic aferent încălzirii apei	η_{wh}	85	87	%
Consumul zilnic de energie electrică	Qelec	0,173	0,102	kWh
Consumul zilnic de combustibil	Qfuel	23,014	22,524	kWh
Consumul anual de energie electrică	AEC	38	22	kWh
Consumul anual de combustibil	AFC	17	17	GJ

(*) regim de temperatură ridicată: 60°C la intrarea în instalația de încălzire și 80°C la ieșire





(**) regim de temperatură scăzută: pentru cazanele cu condensare la 30°C, pentru cazanele cu temperatură scăzută la 37°C, pentru alte instalații de încălzire la o temperatură de 50°C la intrare



Pentru centralele de încălzire combinate: CENTRALĂ CU DOSSERET

Parametru	Simbol	25 HM BIS	35 HM BIS	Unit
Profil sarcină		XL	XL	
Consum zilnic de energie electrică	Qelec	0,352	0,354	kWh
Consum anual de energie electrică	AEC	77	78	kWh
Eficiență energetică de încălzire a apei	η_{wh}	80	82	%
Consum zilnic de carburant	Qfuel	23,964	23,370	kWh
Consum anual de carburant	AFC	18	18	GJ

(*) regim de temperatură ridicată: 60°C la intrarea în instalația de încălzire și 80°C la ieșire

(**) regim de temperatură scăzută: pentru cazanele cu condensare la 30°C, pentru cazanele cu temperatură scăzută la 37°C, pentru alte instalații de încălzire la o temperatură de 50°C la intrare

RIELLO		RIELLO S.p.A. - Via Ing. Pilade Riello, 7 - 37045 Legnago (Vr)					
						0476/00	
RESIDENCE AQUA HM BIS		D: l/min		Q _{hw}	Q _n	Q _m	Q _n
Serial N.		COD.		80-60 °C	80-60 °C	50-30 °C	
230 V ~ 50 Hz	W		NOx:	Q _n (Hi) =	kW	kW	kW
	P _{mw} = bar	T = °C	IP	P _n =	kW	kW	kW
	P _{ms} = bar	T = °C					

RO	
Q _{hw}	Capacitate nominală apă menajeră
Q _n	Capacitate nominală pentru încălzire
Q _m	Capacitate minimă pentru încălzire
Q _n (Hi)	Capacitate nominală (putere calorifică inferioară)
P _n	Putere nominală
 P _{ms}	Presiune maximă de funcționare încălzire
 P _{mw}	Presiune maximă de funcționare pentru apă caldă menajeră
T	Temperatură
IP	Grad de protecție
NOx	Clasa NOx
D	Capacitate specifică

4 INSTALARE

4.1 Curățarea instalației și caracteristicile apei

În cazul unei noi instalări sau al înlocuirii centralei, trebuie să efectuați o curățare preventivă a instalației de încălzire. Pentru a garanta buna funcționare a produsului, după fiecare operațiune de curățare, adăugare de aditivi și/sau tratamente chimice (de exemplu, antiîngheț, peliculă etc. ...), asigurați-vă că parametrii din tabel se încadrează în valorile indicate.

PARAMETRI	udm	APA DIN CIRCUITUL DE ÎNCĂLZIRE	APA DE UMLERE
Valoare pH	-	7-8	-
Duritate	°F	-	< 15
Aspect	-	-	limpede
Fe	mg/kg	< 0,5	-
Cu	mg/kg	< 0,1	-

Centrala trebuie să fie conectată la o instalație de încălzire și la o rețea de apă sanitară, ambele dimensionate în baza performanțelor sale și în baza puterii sale.

Înainte de instalare, se recomandă efectuarea unei clătiri riguroase a tuturor conductelor instalației, pentru a îndepărta eventualele reziduuri care ar putea compromite funcționarea corespunzătoare a centralei.

Instalați sub supapa de siguranță o pâlnie pentru colectarea apei cu o conductă de evacuare adecvată în caz că are loc o scurgere din cauza suprapresiunii în instalația de încălzire. Circuitul apei menajere nu are nevoie de supapă de siguranță, dar trebuie să vă asigurați că presiunea din conducta de apă nu depășește 6 bari. În cazul în care există incertitudini, va trebui instalat un reductor de presiune.



Înainte de pornire, asigurați-vă că centrala este pregătită pentru funcționare și că este alimentată cu gaz; acest lucru reiese de pe ambalaj și de pe eticheta autocolantă, pe care este indicat tipul de gaz.



Este foarte important să se sublinieze că, în anumite cazuri, coșurile de fum se află sub presiune și, așadar, îmbinările diferitelor elemente trebuie să fie ermetice.

4.2 Norme privind instalarea

Instalarea trebuie să fie efectuată de personal calificat, în conformitate cu următoarele normative de referință:

- UNI 7129-7131, CEI 64-8.



În faza de instalare a centralei, se recomandă să utilizați echipamente de protecție pentru a evita accidentările personale.

În plus, trebuie respectate întotdeauna normele locale ale pompierilor, ale companiei de gaz și alte eventuale prevederi municipale.

AMPLASARE

Această centrală în condensatie de tip C a fost concepută pentru încălzire și pentru producerea apei calde menajere care, în funcție de tipul de instalare, se împarte în două categorii:

- centrală de tip B23P-B53P; instalare forțată deschisă, cu conductă de evacuare a gazelor arse și aspirare a aerului de ardere din mediul în care este instalată;
- Centrală de tip C(10)3; C13,C13x; C33,C33x; C43,C43x; C53,C53x; C63,C63x; C83,C83x; C93,C93x: aparat cu carcasă etanșă, cu conductă de evacuare a gazelor arse și aspirare a aerului de ardere din exterior. Nu necesită priză de aer în spațiul în care este instalată.

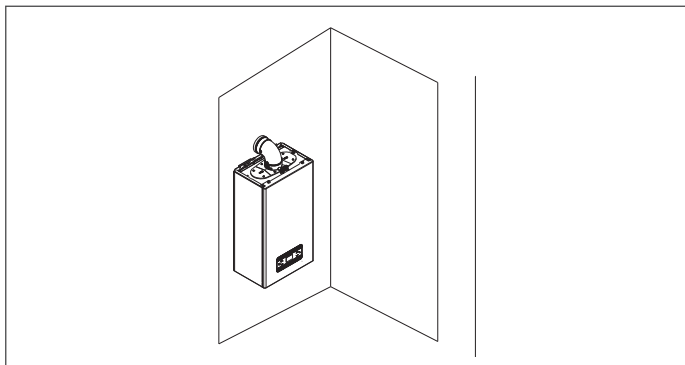

SISTEM DE PROTECȚIE LA ÎNGHEȚ

Centrala este echipată în serie cu un sistem automat de protecție împotriva înghețului, care se activează atunci când temperatura apei din circuitul principal scade sub 5°C. Acest sistem este întotdeauna activ și garantează protecția centralei, până la o temperatură a aerului de la locul de instalare de >0°C.



Pentru a beneficia de această protecție, bazată pe funcționarea arzătorului, centrala trebuie să poată fi pornită; prin urmare, orice condiție de blocare (de exemplu, lipsa alimentării cu gaz sau cu energie electrică) dezactivează protecția.

În cazul în care centrala este lăsată fără alimentare pentru perioade lungi de timp în zone în care pot fi atinse temperaturi mai mici de >0°C și nu se dorește golirea instalației de încălzire, pentru protecția împotriva înghețului a centralei se recomandă introducerea în circuitul principal a unui lichid de bună calitate de protecție împotriva înghețului. Urmăriți cu rigurozitate instrucțiunile producătorului în ceea ce privește procentul de lichid de protecție împotriva înghețului în raport cu temperatura minimă la care se dorește menținerea circuitului aparatului, durata sau eliminarea lichidului.

În ceea ce privește circuitul de apă caldă menajeră, se recomandă golirea acestuia.

Materialele din care sunt realizate componentele centralei rezistă la lichide antiîngheț pe bază de glicol etilenici.

DISTANȚE MINIME

Accesați partea de interior a centralei în vederea efectuării operațiilor de întreținere normală, respectând spațiile minime prevăzute pentru instalare.

Poziționați centrala, ținând cont de următoarele:

- trebuie să fie instalată pe un perete adecvat să susțină greutatea acesteia
- nu trebuie amplasată deasupra bucătăriei sau a altui aparat de gătit
- nu trebuie să lăsați substanțe inflamabile în încăperea în care este instalată centrala.

DISTANȚE MINIME PENTRU ÎNTREȚINERE

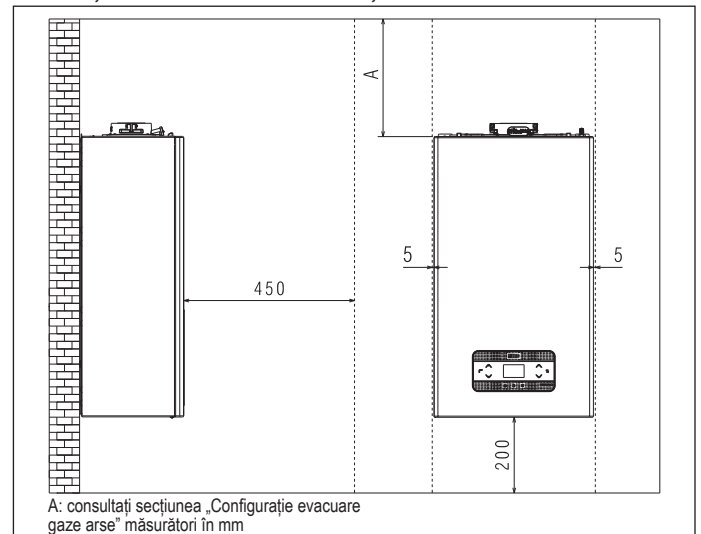

DISTANȚE MINIME PENTRU INSTALAREA ÎN DULAP

- Respectați o distanță de siguranță între peretele pe care este instalată centrala și părțile calde din exteriorul acesteia.

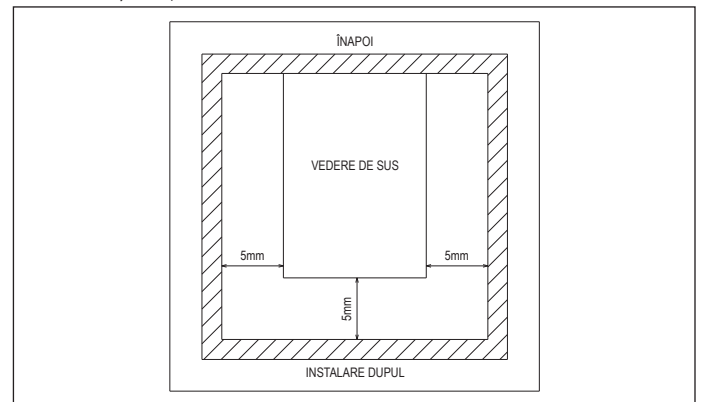

4.3 Kit Dossieret (disponibil la cerere)

Kitul Dossieret combinat cu centrala vă permite să aveți o rezervă de apă întotdeauna disponibilă la temperatura dorită.

Sistemul format dintr-o centrală cu un dispozitiv de încălzire de 30 litri este simplu de asamblat: primul pas este instalarea dispozitivului de încălzire montat pe perete cu alegerea racordurilor de apă menajeră care permit conectarea la centrală.

Instalare:

- fixați șablonul pentru dossieret la perete (1)
- montați șablonul de fixare a centralei la dossieret (2)
- asamblați seturile de furtunuri hidraulice și setul comutatorului de debit (3) (disponibile la cerere)
- cuplați centrala la șablon (4)
- efectuați conexiunile hidraulice între dossieret și centrală
- efectuați conexiunea electrică între dossieret și centrală.

Consultați instrucțiunile specifice din kit pentru detalii suplimentare.

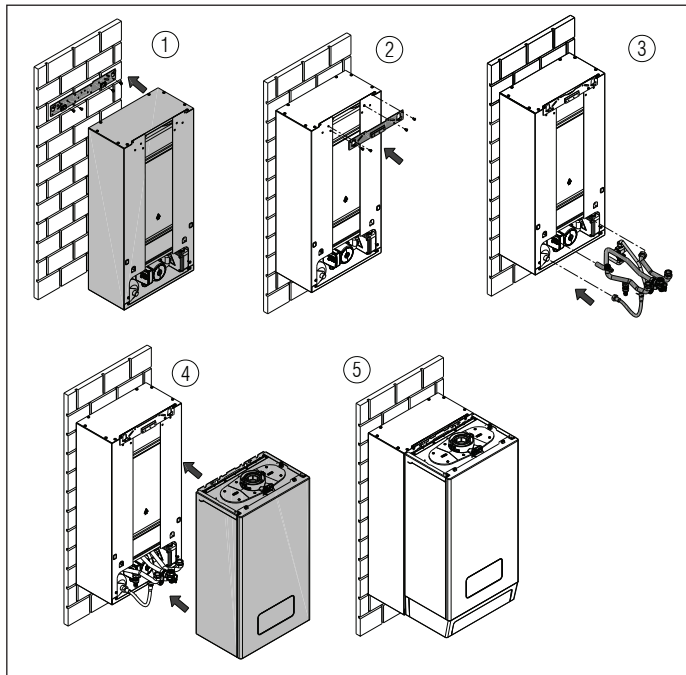

Dispozitivul de încălzire cu tehnologie de depozitare cu două rezervoare are aceeași performanță ca și dispozitivele de încălzire cu serpentină de 45 și 60 litri, dar cu spații considerabil limitate.

Este posibil, prin intermediul parametrului electronic, să se excludă funcționalitatea centralei prin folosirea acesteia în modul instant.

P520 = 1 fierbător activat, stocare apă menajeră

P520 = 0 funcționalitate fierbător exclusă, centrala funcționează în modul instant, asigurând economii la consumul de gaz

Parametrul **P521** gestionează frecvența de resetare a fierbătorului:

COMFORT face ca centrala să aibă cicluri de umplere a dispozitivului de încălzire mai mari și mai frecvente. Această setare, pentru care cazanul a fost proiectat în termeni de performanță mai bună, este tipică aplicațiilor domestice unde se dorește prioritizarea aspectului de performanță sanitară a sistemului.

ECO face ca centrala să aibă un număr redus de cicluri de umplere a dispozitivelor de încălzire. Această alegere trebuie făcută atunci când doriți economii mai mari de energie, dar limitați performanțele sanitare ale sistemului.

⚠ Acești parametri trebuie setați înainte de utilizarea centralei.

⚠ În starea OFF, ciclul de resetare a fierbătorului este dezactivat. Ciclul de resetare a dispozitivului de încălzire suspendă temporar executarea unui ciclu de încălzire a încăperii.

⚠ În timpul unui ciclu de încălzire a fierbătorului, afișajul centralei indică TCHG (u P105 = 1 text derulant --> ÎNCĂRCAREA RUC-SACULUI).

⚠ Un ciclu de încălzire se efectuează după o pornire, după aproximativ 3 minute de la o cerere de apă menajeră, între o trecere de la starea OFF la starea de VARĂ/IARNĂ, la închiderea programatorului orar de apă menajeră (POS).

⚠ În cazul lipsei de comunicare între placa centralei și setul dossier (conexiune BUS 485 - pentru detalii, consultați instrucțiunile din setul dossier), pe afișaj apare eroarea E066 (cu P105 = 1 text derulant --> DOSSERET (P520=0) pentru timpul necesar înlocuirii circulatorului menajer în DOSSERET). Centrala este forțată să intre în starea OFF.

⚠ În caz de funcționare incorectă a pompei de circulație sanitară în DOSSERET, cum ar fi blocul electric sau mecanic, sistemul nu furnizează semnale. În acest caz, se poate produce atât scăderea performanței ACM cât și lipsa funcționalității sistemului de încălzire. Serviciul de asistență tehnică va putea dezactiva temporar funcționalitatea DOSSERET (P520=0) pentru timpul necesar înlocuirii circulatorului menajer în DOSSERET.

⚠ În cazul unei lipse de comunicare între placa centralei și placa de reglare, modul de resetare a centralei este întrerupt.

Pentru a finaliza instalarea, utilizați kitul de accesorii de mai jos:

- țevi hidraulice
- comutator de debit cu țevi
- capac de montare
- dozator compact de polifosfat (în cazul unui boiler cu dozator încorporat).

Pentru mai multe informații, consultați catalogul.

4.4 Instrucțiuni privind conexiunea de evacuare condens

Acest produs a fost proiectat să împiedice scurgerile de produși gazeși de ardere prin intermediul conductei de evacuare a condensului cu care este dotat; respectiv, este obținut prin utilizarea unui sifon corespunzător din interiorul echipamentului.

⚠ Toate componentele ce constituie sistemul de evacuare a condensului produsului sunt întreținute corect conform indicațiilor producătorului și nu pot fi modificate în niciun mod.

Instalația de evacuare a condensului în aval față de echipament trebuie să respecte legislația și normele aplicabile în domeniu. Realizarea instalației de evacuare a condensului în aval a echipamentului reprezintă responsabilitatea instalatorului. Instalația de evacuare a condensului trebuie să fie dimensionată și instalată astfel încât să se asigure evacuarea corespunzătoare a condensului generat de aparat și/sau colectat din sistemele de evacuare a produșilor de ardere. Toate componentele sistemului de evacuare a condensului trebuie să fie realizate în condiții optime, cu materiale adecvate pentru a rezista în timp la solicitările mecanice, termice și chimice ale condensului generat de echipament.

Observație: În cazul în care sistemul de evacuare a condensului este expus riscului de îngheț, asigurați mereu un nivel adecvat de izolație la nivelul conductei și aveți în vedere o eventuală mărire a diametrului conductei respective.

Conducta de evacuare a condensului trebuie să prezinte mereu un nivel adecvat de înclinare pentru a evita acumularea condensului și pentru corecta sa evacuare. Sistemul de evacuare a condensului trebuie să fie prevăzut cu o separare, ce poate fi inspectată, între conducta de evacuare a condensului echipamentului și sistemul de evacuare a condensului.

4.5 Acces la părțile electrice

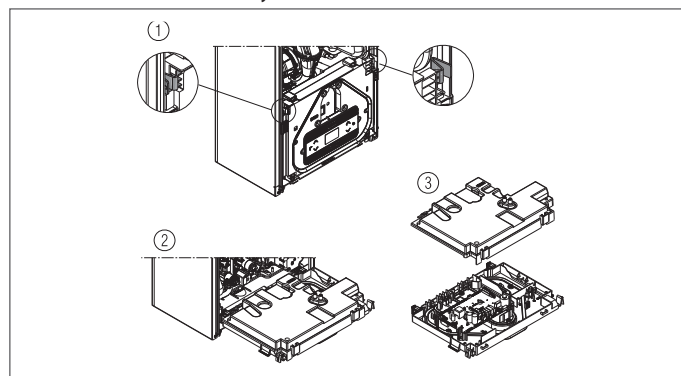

4.6 Conexiunea electrică

Conexiuni de joasă tensiune

Efectuați conexiunile electrice de joasă tensiune, după cum urmează:

- Utilizați conectoarele furnizate în dotarea centralei
 - conector ModBus 4 poli pentru semnalul BUS 485 (- A B +)
 - conector 8 poli pentru semnale TBT - TA -OT+ - SE

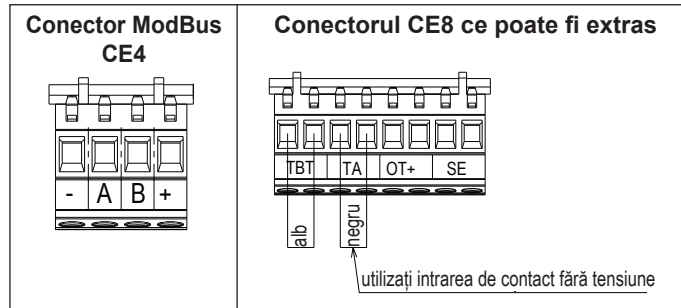

CE4	(- A B +)	Magistrală 485
	TBT	Termostat de joasă temperatură
CE8	TA	Termostat de ambient (contact liber de tensiune)
	OT+	Open therm
	SE	Sondă externă

- efectuați conexiunile electrice folosind conectorul dorit conform celor indicate în schița de detalii
- după asigurarea conexiunilor electrice, introduceți corect conectorul în partea corespunzătoare.

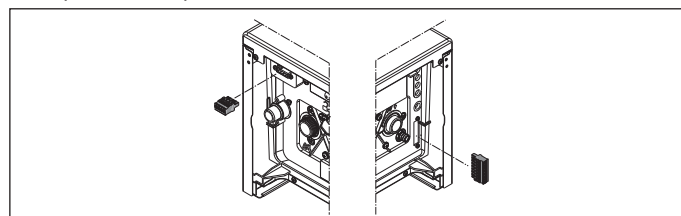

⚠ Se recomandă utilizarea conductorilor cu secțiuni transversale ale firelor de la minim 0,35 mm² până la maxim 1,5 mm². Pentru conectarea BUS 485 se recomandă utilizarea cablului ecranat dacă semnalul trece în apropierea altor conductori electrici sau conductori de tensiune de rețea.

⚠ În cazul unui racord TA sau TBT, eliminați punțile aferente prezente în cutia cu borne.

OBSERVAȚIE: în cazul conectării la sistem a unei comenzi la distanță OT+, dacă parametrul P803= 1 (SERVICE), pe ecranul centralei apare următorul afișaj:



Notă: Compatibilitatea totală cu dispozitive OpenTherm ale terților nu este garantată.

Se observă, de asemenea, că, dacă este conectată comanda la distanță OT+:

- nu mai este posibilă setarea stării centralei de DEZACTIVARE/IARNĂ/VARĂ (este setată prin comanda la distanță OT+)
- nu mai este posibilă setarea valorii de referință pentru apa menajeră (este setată prin comanda la distanță OT+)
- combinația de taste **A+B** rămâne activă pentru setarea funcției CONFORT ACM
- Valoarea de referință pentru apa menajeră (I005) este afișată în meniul INFO
- Valoarea de referință pentru încălzire calculată prin comanda la distanță OT+ (I017) este afișată în meniul INFO
- este posibilă setarea valorii de referință pentru încălzire la nivelul centralei doar dacă P311=1 sau P311 = 0 și „puntea” este închisă. Valoarea poate fi consultată în meniul INFO (I016)
- pentru activarea funcției COȘAR, cu comanda la distanță OT+ conectată, este necesar să dezactivați temporar conexiunea setând parametrul P803 = 0 (SERVICE); nu uitați să restabiliți valoarea acestui parametru după finalizarea funcției.

Tasta 2 rămâne activă pentru resetarea alarmei.

Tasta 3 rămâne activă pentru vizualizarea meniului INFO și activarea meniului SETARI.

Conexiuni de înaltă tensiune

Conectarea la rețeaua electrică trebuie să fie realizată prin intermediul unui dispozitiv de separare cu deschidere omipolară de cel puțin 3,5 mm (EN 60335/1 - categoria 3). Aparatul funcționează la curent alternativ de 230 Volți/50 Hz, și este conform cu norma EN 60335-1. Este obligatorie conectarea cu o împământare eficientă, conform normativelor în vigoare.

⚠ Este responsabilitatea instalatorului să asigure o împământare adecvată a aparatului; producătorul nu își asumă răspunderea pentru eventualele daune cauzate de realizarea incorectă sau de nerealizarea acesteia.

⚠ SE recomandă, în plus, respectarea conexiunii fază-nul (L-N).

⚠ Conductorul de legare la pământ trebuie să fie cu câțiva centimetri mai lung decât celelalte.

⚠ Pentru a garanta etanșeitatea centralei, utilizați o garnitură și strângeți-o la nivelul canalului de cablu folosit.

Centrala poate să funcționeze cu alimentare fază-nul sau fază-fază. Este interzisă utilizarea conductelor de gaz și/sau de apă ca împământare pentru aparaturile electrice. Pentru conexiunea electrică, folosiți cablul de alimentare din dotare. În cazul înlocuirii cablului de alimentare, utilizați un cablu de tipul HAR H05V2V2-F, 3x 0,75 mm², Ø max extern 7 mm.

4.7 Conexiunea de gaz

Racordarea la gaz trebuie executată cu respectarea normelor de instalare în vigoare. Înainte de a efectua racordul:

- asigurați-vă că gazul furnizat corespunde celui pentru care a fost fabricată centrala (consultați plăcuța cu date tehnice).

4.8 Demontarea carcasei

Pentru a avea acces la componentele interne, îndepărtați carcasa, după cum este indicat în figură.

⚠ În cazul demontării panourilor laterale, montați-le la loc în poziția inițială, consultând eticheta adezivă de pe partea laterală.

⚠ Eventuala deteriorare a panoului frontal conduce la înlocuirea panoului.

⚠ Panourile izolate fonic prezente în interiorul pereților frontali și laterali pot garanta etanșeitatea circuitului de admisie a aerului față de mediul de instalare.

⚠ Este, prin urmare, ESENȚIAL ca după operațiunile de demontare să montați la loc corect componentele, pentru a garanta etanșeitatea centralei.

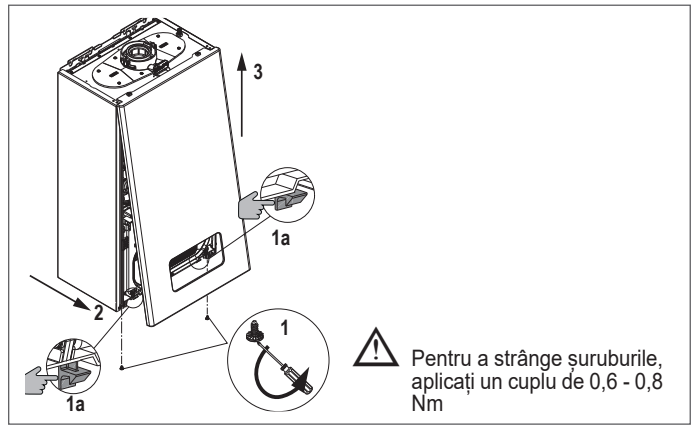

4.9 Evacuarea gazelor arse și aspirarea aerului de ardere

Pentru evacuarea produșilor de ardere, consultați normativă UNI7129-7131. În plus, trebuie respectate întotdeauna normele locale ale pompierilor, ale companiei de gaz și alte eventuale prevederi municipale.

Pentru extracția gazelor de ardere și admisia aerului de ardere la centralei, este neapărat necesar să fie utilizate doar conducte originale (cu excepția tipului C6 cu condiția să fie certificate) și conexiunile să fie efectuate în mod corect, astfel cum este indicat în instrucțiunile din dotarea accesoriilor pentru gazele arse. La un singur coș de fum pot fi conectate mai multe aparate, cu condiția ca toate să fie cu condensare.

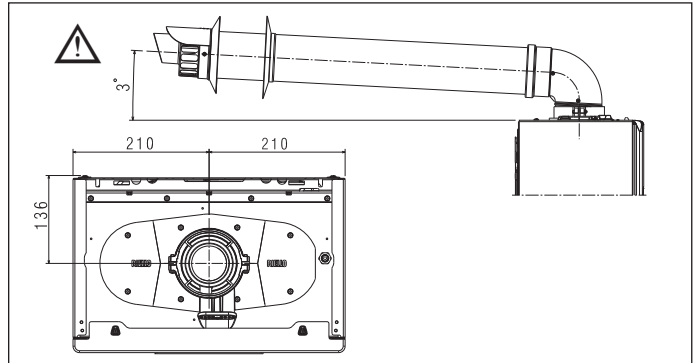

⚠ Gura de evacuare a gazelor arse a centralei este dimensionată pentru un conduct concentric cu diametrul exterior al tubului de evacuare a gazelor de 60 +0,6 -0,3 mm și diametrul exterior al tubului de admisie a aerului de 100 +0,3 -0,7 mm. Asigurați-vă că îmbinarea este etanșă.

⚠ Nu instalați elementele de evacuare a gazelor arse în apropierea unor materiale inflamabile sau plastice, ale căror caracteristici pot fi modificate în cazul unor temperaturi ridicate.

⚠ Lungimea rectilinie este fără coturi și include terminale și îmbinări.

⚠ Centrala este furnizată fără kitul pentru evacuarea gazelor arse/aspirația aerului, întrucât pot fi folosite accesoriile pentru aparatele cu condensare care se adaptează cel mai bine la caracteristicile de instalare (consultați catalogul).

⚠ În cazul utilizării de conducte de evacuare gaze arse și aspirație aer, care nu sunt originale, trebuie să se garanteze totuși utilizarea unor conducte certificate și conforme cu echipamentul la care sunt racordate, cu o clasă de temperatură $\geq 120^{\circ}\text{C}$, și rezistente la condens.

⚠ Pentru a garanta un nivel ridicat de siguranță al instalației, fixați pe zid (perete sau plafon) conductele prin utilizarea unor cleme de fixare specifice ce trebuie poziționate în corespondență cu fiecare îmbinare, la o distanță care să nu depășească lungimea fiecărei extensii individuale și imediat înainte și după fiecare schimb de direcție (curbă).

⚠ Lungimile maxime ale conductelor se referă la conexiunile pentru coșul de fum disponibile în catalog.

⚠ Este obligatorie utilizarea conductelor specifice.

⚠ Pereții sensibili la căldură (de exemplu, cei din lemn) trebuie să fie protejați cu o izolație adecvată.

⚠ Conductele de evacuare a gazelor de ardere neizolate sunt potențiale surse de pericol.

⚠ Utilizarea unei conducte cu o lungime mai mare duce la o pierdere a puterii centralei.

⚠ Conductele de evacuare pot fi orientate în direcția cea mai potrivită pentru necesitățile de instalare.

⚠ După cum prevăd normele în vigoare, centrala poate primi și a evacua prin intermediul sifonului propriu condensul din gazele arse și/sau apele meteorice provenite din sistemul de evacuare a gazelor arse.

⚠ În cazul în care este instalată o eventuală pompă de relansare pentru condens, verificați datele tehnice privind debitul furnizate de către producător pentru a asigura corecta funcționare a acesteia.

- Poziționați conducta de evacuare astfel încât inserția să intre complet în contact cu turnul pentru gaze arse al centralei.
- După amplasare, asigurați-vă că cele 4 creștături (A) sunt introduse în canalul corespunzător (B).
- Strângeți complet șuruburile (C) care strâng cele două borne de blocare a flanșei, astfel încât cotul să fie fixat la aceasta.

Pentru lungimile de evacuare, consultați aspectele indicate în capitolul "Tabel de configurare a evacuării fumului" de la paginile 81-82.

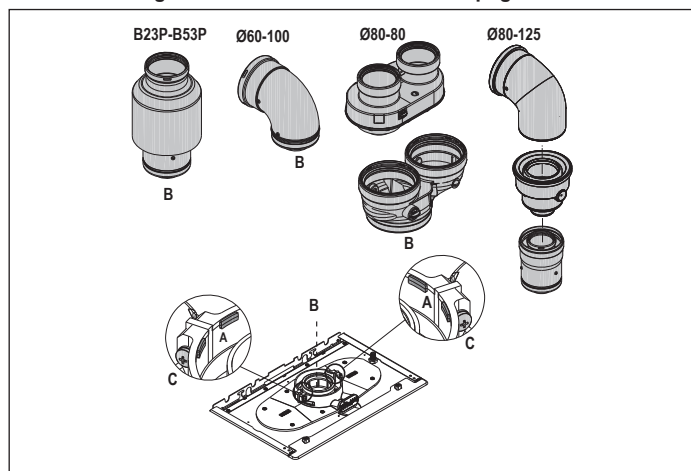

Sistem conductă dublă de fum cu utilizarea kit-ului de conectare a sistemului conductă dublă de fum Ø80 (accesoriu)

⚠ Conexiunile kitului de racordare split Ø 80 sunt dimensionate pentru conducte cu un diametru exterior de 80 +0,3 -0,7 mm. Asigurați-vă că îmbinarea este etanșă.

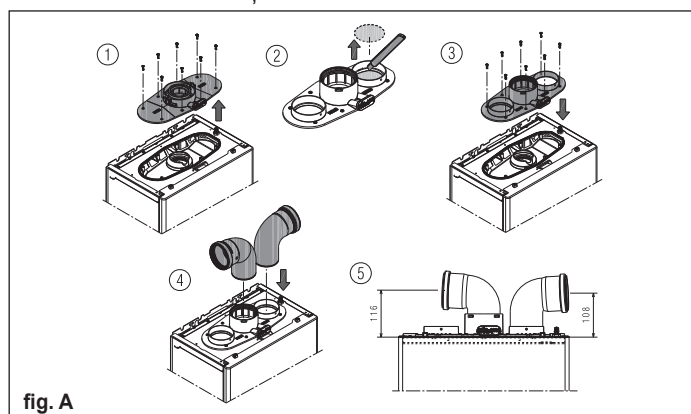

Dacă se utilizează kitul de ramificare de la Ø 60-100 la Ø 80-80 în locul sistemului ramificat, se determină o pierdere a lungimilor maxime conform celor indicate în tabel.

	Ø 50	Ø 60	Ø 80
Pierdere de lungime (m)	0,5	1,2	5,5 pentru conducta de gaze arse 7,5 pentru conducta de aer

Conducte separate ø 80 cu cuplare de Ø50 - Ø60 - Ø80

Caracteristicile centralei permit conectarea conductei de evacuare a gazelor arse (ø 80) la diferitele modele de țevi ale instalației Ø50 - Ø60 - Ø80.

⚠ Pentru stabilirea țevilor instalației, se recomandă efectuarea unui calcul de proiect în vederea asigurării conformității cu normele în vigoare.

În tabel se regăsesc configurațiile de bază admise.

Tabel al configurațiilor de bază ale conductelor (*)

Admisie aer	1 cot de 90° ø 80 conductă de 4,5m ø 80
Evacuare gaze arse	1 cot de 90° ø 80 conductă de 4,5m ø 80 Reducție de la ø 80 la ø 50 sau de la ø 80 la ø 60 Cot bază coș 90°, ø 50 sau ø 60 sau ø 80 Pentru lungimile conductei instalației, consultați tabelul

(*) Utilizați conducte din plastic (PP) adecvate pentru centrale cu condensare și cu clase de presiune (P1 până la 200 Pa - H1 până la 5000 Pa) adecvate pentru utilizare, consultând valoarea de DP de ieșire centrală indicată în „Tabelul de reglaje”.

Centralele ies din fabrică reglate astfel:

		ÎNC rpm	ACM rpm	Lungime maximă (m)		
				Ø50	Ø60	Ø80
25 HM BIS		6.300	7.900	7	23	116
				6	20	98
35 HM BIS		7.400	8.600	2	12	62
				1	11	57

Dacă sunt necesare lungimi mai mari, compensați pierderile de sarcină cu o creștere a numărului de rotații ale ventilatorului, după cum este prezentat în tabelul cu reglaje, pentru a asigura debitul termic indicat pe plăcuță.

⚠ Calibrarea valorii minime nu trebuie modificată.

Tabele cu reglaje CONDUCTE PENTRU SISTEMUL DE ȚEVI - G20

conductă dublă de fum						
	Turație ventil. rpm		Conducte Ø 50	Conducte Ø 60	Conducte Ø 80	ΔP ieșire centrală (Pa)
	ÎNC	ACM	lungime maximă (m)			
25 HM BIS	6.300	7.900	7	23	116	180
	6.400	8.000	9*	29*	144*	210*
	6.500	8.100	11*	34*	172*	257*
	6.600	8.200	14*	40*	201*	285*
	6.700	8.300	16*	46*	229*	330*
	6.800	8.400	18*	51*	257*	355*
	6.900	8.500	21*	57*	285*	385*
	7.000	8.600	23*	63*	314*	425*
	7.100	8.700	25*	68*	342*	465*
	7.200	8.800	28*	74*	370*	497*
35 HM BIS	7.400	8.600	2	12	62	195
	7.500	8.700	4*	18*	92*	242*
	7.600	8.800	6*	24*	119*	289*
	7.700	8.900	9*	29*	145*	337*
	7.800	9.000	11*	34*	172*	384*

(*) Lungimea maximă instalabilă DOAR cu conducte de evacuare în clasa H1.

conductă dublă compactă de fum						
	Turație ventil. rpm		Conducte Ø 50	Conducte Ø 60	Conducte Ø 80	ΔP ieșire centrală (Pa)
	ÎNC	ACM	lungime maximă (m)			
25 HM BIS	6.300	7.900	6	20	98	170
	6.400	8.000	8*	25*	124*	203*
	6.500	8.100	10*	30*	150*	235*
	6.600	8.200	13*	35*	176*	268*
	6.700	8.300	15*	40*	202*	300*
	6.800	8.400	17*	46*	228*	333*
	6.900	8.500	19*	51*	253*	365*
	7.000	8.600	21*	56*	279*	398*
	7.100	8.700	23*	61*	305*	430*
	7.200	8.800	25*	66*	331*	463*
35 HM BIS	7.400	8.600	1	11	57	180
	7.500	8.700	3*	17*	84*	227*
	7.600	8.800	6*	22*	111*	274*
	7.700	8.900	8*	28*	138*	322*
	7.800	9.000	10*	33*	165*	369*

(*) Lungimea maximă instalabilă DOAR cu conducte de evacuare în clasa H1.

Configurațiile Ø 50 sau Ø 60 sau Ø 80 oferă date experimentale verificate în Laborator. În cazul unor instalații diferite față de cele indicate în tabelele cu „configurări standard” și „reglaje”, consultați lungimile liniare echivalente din continuare.

⚠ În orice caz, sunt garantate lungimile maxime declarate în manual și este deosebit de important ca acestea să nu fie depășite.

COMPONENTĂ	Echivalentul în metri liniari Ø80 (m)	
	Ø 50	Ø 60
Cot de 45°	12,3	5
Cot de 90°	19,6	8
Extensie de 0,5 m	6,1	2,5

COMPONENTĂ	Echivalentul în metri liniari Ø80 (m)	
Extensie de 1,0m	13,5	5,5
Extensie de 2,0m	29,5	12

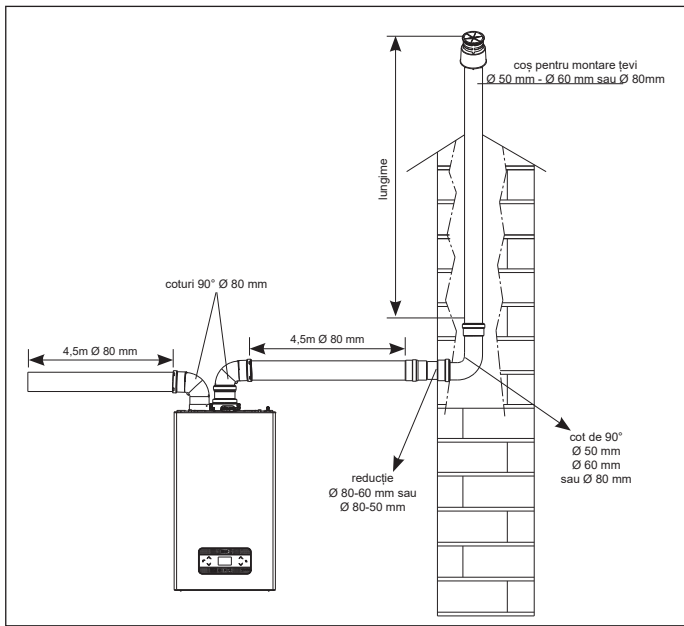

4.10 Instalare pe coșurile de fum colective cu presiune pozitivă

Coșul de fum colectiv este un sistem de evacuarea gazelor arse adecvat pentru a colecta și a evacua producții de ardere provenind de la mai multe aparate, instalate la mai multe etaje ale unei clădiri. Coșurile de fum colective cu presiune pozitivă pot fi utilizate doar pentru aparate cu condensare de tip C. Drept urmare, configurația B53P/B23P este interzisă. Instalarea centralelor pe coșurile de fum colective sub presiune este permisă exclusiv **pentru gaz metan natural**. Centrala este dimensionată să funcționeze corect până la o presiune maximă internă a coșului de fum care să nu depășească valoarea de 25 Pa. Asigurați-vă că numărul de rotații ale ventilatorului este conform cu valoarea indicată în tabelul de „date tehnice”.

Asigurați-vă că tuburile de aspirare a aerului și de evacuare a produșilor de combustie sunt etanșe.

Instalarea în coșuri colective presurizate este posibilă numai prin utilizarea trusei accesoriei clapet cu sifon integrat, care se instalează imediat la ieșirea din conducta de evacuare a gazelor arse (kit Ø80) sau a conductei de evacuare/aspirare a gazelor arse (kit Ø80/125).

NOTA: Utilizarea kit-ului clapet Ø80 necesită utilizarea kit-ului de conectare a sistemului dublu Ø80 (fig. A - 2, pagina 34).

Seturile de accesoriei clapet cu sifon integrat disponibile în catalog sunt potrivite pentru colectarea și curgerea condensului în interiorul cazanului.

AVERTISMENTE:

- ⚠ Aparatele conectate la un coș colectiv trebuie să fie de același tip și trebuie să aibă caracteristici de ardere asemănătoare.
- ⚠ Numărul de aparate care pot fi conectate la un coș colectiv cu presiune pozitivă este stabilit de proiectantul coșului.

Centrala este proiectată pentru a fi conectată la un coș colectiv de fum dimensionat pentru a opera în condiții în care presiunea statică a conductei colective de gaze de ardere poate depăși presiunea statică a conductei colective de aer de 25 Pa în condiții în care n-1 centrale funcționează la capacitatea termică nominală maximă și 1 centrală la capacitatea termică minimă admisă de controale.

- ⚠ Diferența minimă de presiune admisă între ieșirea gazelor arse și intrarea aerului de ardere este de -200 Pa (incluzând - 100 Pa presiunea vântului).

Pentru această tipologie de evacuare sunt disponibile accesoriile suplimentare (coturi, piese prelungitoare, terminale etc.) care fac posibile configurațiile de evacuare gaze arse prevăzute în manualul de instrucțiuni al centralei.

- ⚠ Montarea supapei de reținere (kit clapet), disponibilă în catalog, este obligatorie.
- ⚠ Montarea conductelor trebuie să fie realizată pentru a evita contracurenții de condens care ar împiedica evacuarea corectă a produșilor de ardere.
- ⚠ Trebuie asigurată o plăcuță de identificare cu date tehnice la punctul de racord cu conducta de gaze arse colectivă. Plăcuța cu date de identificare trebuie să prezinte cel puțin următoarele informații:
 - coșul de fum colectiv este dimensionat pentru centrale de tip C(10)3
 - debitul masic maxim admis al produșilor de ardere în kg/h
 - dimensiunile conexiunii la conductele comune

- o notificare referitoare la deschideri pentru ieșirea aerului și intrarea produșilor de ardere ale coșului de fum colectiv sub presiune; aceste deschideri trebuie să fie închise și trebuie să fie asigurată etanșeitatea lor când centrala este deconectată
- numele producătorului conductei colective de gaze arse sau simbolul său de identificare

- ⚠ Consultați normele în vigoare pentru evacuarea produșilor de ardere și prevederile locale.
- ⚠ Conducta de gaze arse trebuie să fie selectată în mod corect în baza parametrilor indicați în ceea ce urmează.

	lungime maximă	lungime minimă	UM
Ø 80-80	4,5 + 4,5	0,5	m
Ø 80/125	4,5	0,5	m

- ⚠ Înainte de a efectua oricare operațiuni, opriți alimentarea electrică a echipamentului.
- ⚠ Înainte de montaj, lubrifiați garniturile cu un produs lubrifiant necoroziv.
- ⚠ Conducta de evacuare gaze arse trebuie să fie înclinată în cazul unei conducte orizontale, de 3° spre centrală.
- ⚠ Numărul și caracteristicile echipamentelor conectate la coșul de fum trebuie să fie adecvate pentru caracteristicile reale ale coșului de fum.
- ⚠ Terminalul conductei colective trebuie să genereze tiraj.
- ⚠ Condensul poate ajunge în interiorul centralei.
- ⚠ Valoarea maximă de recirculare admisă în condiții de vânt este de 10%.
- ⚠ Diferența maximă de presiune admisă (25 Pa) dintre intrarea produșilor de ardere și ieșirea aerului ale unui coș de fum colectiv nu poate fi depășită când n-1 centrale funcționează la capacitate termică nominală maximă și 1 centrală la capacitate termică minimă permisă de controale.
- ⚠ Conducta de gaze arse colectivă trebuie să fie adecvată pentru o suprapresiune de minim 200 Pa.
- ⚠ Coșul de fum colectiv nu trebuie să fie prevăzut cu un dispozitiv de rupere tiraj-antivânt.

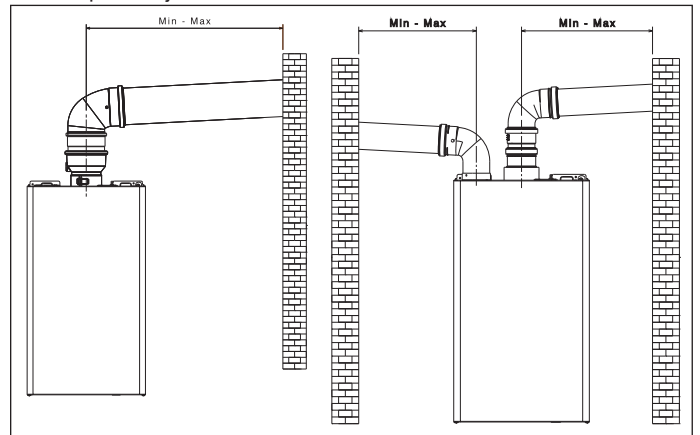

Este posibilă instalarea de coturi și elemente prelungitoare, disponibile ca accesorie, în baza tipului de instalare dorit. Lungimile maxime admise ale conductei de gaze arse și ale conductei de aspirație aer sunt indicate în capitolul "4.8 Evacuarea gazelor arse și aspirarea aerului de ardere”.

Cu instalația C(10)3, indicați în orice caz numărul de rotații ale ventilatorului (rpm) pe eticheta aplicată pe partea laterală a produsului.

4.11 Umplerea sistemului de încălzire și eliminare a aerului

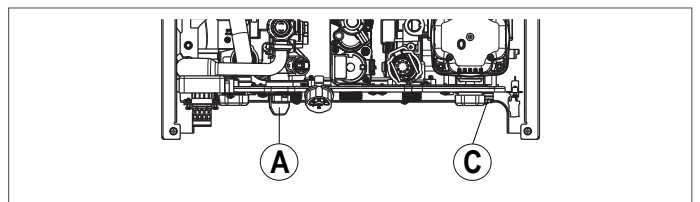

NOTĂ: operațiunile de **umplere** a sistemului trebuie să fie realizate acționând asupra robinetului de umplere (A) asigurându-vă că centrala este alimentată electric.

NOTĂ: de fiecare dată când centrala este alimentată electric, se efectuează **ciclul de purjare automat**.

NOTĂ: prezența unei alarme pentru apă (E040, E041 sau E042) nu permite efectuarea ciclului de purjare.

Treceți la umplerea instalației de încălzire efectuând următoarele operațiuni:

- deschideți robinetul de umplere (A) rotindu-l spre stânga
- verificați dacă valoarea presiunii atinge 1-1,5 bar prin intermediul hidrometrului amplasat sub consolă
- închideți robinetul de umplere (A).

NOTĂ: dacă presiunea de rețea este inferioară valorii de 1 bar, mențineți deschis robinetul de umplere (A) în timpul ciclului de purjare și închideți-l după finalizare.

Pentru a activa ciclul de purjare:

- întrerupeți alimentarea cu energie electrică timp de câteva secunde
- reluați alimentarea cu energie electrică lăsând centrala în starea de DEZACTIVARE
- Asigurați-vă că robinetul de gaz este închis.

La finalul ciclului, dacă presiunea circuitului este redusă, acționați din nou asupra robinetului de umplere (A) pentru a readuce presiunea la valoarea recomandată (1-1,5 bar).

După ciclul de purjare, centrala este pregătită.

- Eliminați eventualul aer prezent în instalațiile domestice (radiatoare, colectoare zonale etc.) prin supapele de purjare aferente.
- Verificați din nou presiunea corectă prezentă în instalație (ideal, 1-1,5 bar) și eventual stabiliți din nou presiunea.
- Dacă, în timpul funcționării, ar apărea o atenționare referitoare la prezența aerului, este necesar să repetați ciclul de purjare.
- Încheiați operațiunile, deschideți robinetul de gaz și porniți centrala. În acest moment, este posibilă efectuarea unei solicitări de căldură.

4.12 Evacuare circuit încălzire centrală

Înainte de a începe evacuarea, aduceți centrala în starea de DEZACTIVARE și întrerupeți alimentarea cu energie electrică, poziționând întrerupătorul general al instalației pe „oprit”.

- Închideți robinetele instalației termice (dacă există).
 - Conectați un tub la robinetul de evacuare instalație (C), apoi rotiți-l manual spre stânga pentru a asigura evacuarea apei.
- OBSERVAȚIE: acționați asupra robinetului de evacuare instalație (C) cu o cheie de 13
- După finalizarea operațiunilor, demontați tubul de pe robinetul de evacuare instalație (C) și închideți-l la loc.

4.13 Evacuare circuit apă menajeră centrală

De fiecare dată când există riscul de îngheț, instalația menajeră trebuie să fie golită, procedând după cum urmează:

- închideți robinetul general al rețelei de alimentare cu apă
- deschideți toate robinetele de apă caldă și rece
- goliiți punctele cele mai joase.

5 PUNEREA ÎN FUNCȚIUNE

5.1 Verificări preliminare

Centrala va fi pornită pentru prima dată de personalul competent din cadrul departamentului de asistență tehnică. Înainte de a porni centrala, trebuie să vă asigurați că:

- datele rețelelor de alimentare (cu energie electrică, cu apă, cu gaz) corespund celor de pe plăcuța cu date de identificare
- respectivele conducte de evacuare a gazelor arse și de aspirație aer sunt în conformitate cu normele în vigoare și respectă lungimile maxime admise
- sunt garantate condițiile pentru operațiunile normale de întreținere, în cazul în care centrala este închisă înăuntru sau între corpuri de mobilier
- instalația de alimentare cu carburant este etanșă
- capacitatea carburantului este în conformitate cu valorile impuse pentru centrală
- instalația de alimentare cu carburant este dimensionată în funcție de capacitatea necesară centralei și este echipată cu toate dispozitivele de siguranță și de control prevăzute de normele în vigoare
- circulatorul se rotește liber întrucât, mai ales după perioade lungi în care nu a funcționat, depozitele și/sau reziduurile pot să împiedice rotația liberă
- sifonul este umplut complet cu apă; în caz contrar, umpleți cu apă (consultați capitolul "5.2 Prima punere în funcțiune").

5.2 Prima punere în funcțiune

La prima punere în funcțiune a aparatului, în cazul unei perioade îndelungate de neutilizare și în cazul unei intervenții de întreținere, înainte de punerea în funcțiune a aparatului, este neapărat necesar să procedați conform celor descrise în următoarele paragrafe. La prima pornire, se recomandă și procedura de calibrare (GAC) pentru a permite cazanului să-și atingă performanța optimă. Dacă procedura nu este efectuată, timp de 60 de secunde la fiecare 10 minute, afișajul arată "CFG" (cu P105 = 1 text derulant --> Apelați pentru GAC):



5.2.1 Umplere sifon de colectare condens

Asigurați umplerea sifonului de colectare condens introducând aprox. 1 litru de apă în priză de analiză de ardere a centralei și verificați:

- evacuarea corectă a apei din tubul de evacuare la ieșirea centralei
 - etanșeitățile liniei de conectare pentru evacuare condens.
- O funcționare corectă a circuitului de evacuare condens (sifon și conducte) asigură faptul că nivelul de condens nu depășește nivelul maxim (max).

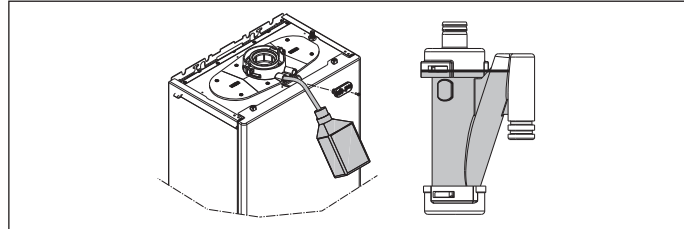

5.3 Ciclu de purjare

Aduceți întrerupătorul general al instalației pe poziția „pornit”.

De fiecare dată când centrala este alimentată, este executat un ciclu de evacuare a aerului cu durata de 4 min. Ecranul se prezintă astfel (cu P105 = 1 text derulant --> CICLU AERISIRE IN CURS):

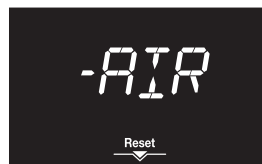

Pentru a întrerupe ciclul de purjare, apăsați pe



Când ciclul de PURJARE este în curs de derulare, toate solicitările de căldură sunt întrerupte exceptându-le pe cele de apă menajeră când centrala nu se află în modul de DEZACTIVARE.

Ciclul de purjare poate fi întrerupt, dacă centrala nu se află în starea de DEZACTIVARE, printr-o solicitare de căldură pentru apă caldă menajeră.

5.4 Procedură de calibrare manuală (GAC)

Procedura GAC, utilă pentru a calibra supapa de gaz și sistemul de comandă a arderii, este obligatorie după: conversia tipurilor de gaz - înlocuirea supapei de gaz - înlocuirea plăcii - înlocuirea ventilatorului - curățarea schimbătorului principal și/sau a arzătorului - înlocuirea electrozudului de detectare flacăra (ionizare) - modificarea conductelor de aspirație/evacuare - curățarea transportorului, curățarea ventilatorului, curățarea filtrului ventilatorului mixerului, înlocuirea schimbătorului, înlocuirea ansamblului schimbător și transportor.

Procedura GAC trebuie să fie efectuată și în cazul primei aprinderi. Dacă această procedură este întârziată în timp, centrala își menține integral siguranța, însă ar putea fi limitată la nivelul de performanțe și poate procesa, de asemenea, semnalele de control al arderii.



Procedura trebuie să fie realizată cu carcasa închisă.

O eventuală repetare a GAC care nu este finalizată în mod corect lasă sistemul în starea „GAC neefectuată”.

Sistemul alternează (cu excepția semnălizării de ALARMĂ, INFO și PROGRAMĂRI) vizualizarea normală cu textul "CFG" (cu P105 = 1 text derulant --> Apelați pentru GAC) pentru a readuce aminte faptul că GAC va fi efectuată și că centrala ar putea avea limitări în funcționare.

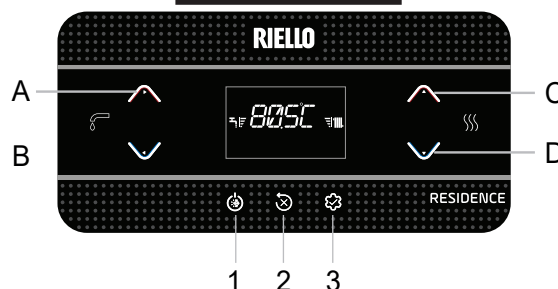

- Alimentați electric centrala și așteptați realizarea ciclului de purjare (consultați paragraful "5.3 Ciclu de purjare", din manualul de instalare).
- Dacă se află în modul de DEZACTIVARE, setați cu tasta 1 anotimpul VARĂ.

- Generați o solicitare pentru apă caldă menajeră, cu un debit de apă caldă menajeră egal sau mai mare de 5 litri pe minut. Deși nu există limitări din partea sistemului, cu excepția celor prevăzute de supravegherea ALARME, cu toate acestea, este recomandabil să faceți scanaarea GAC cu apă din sistemul de retur al cazanului sub 15°C sau, în orice caz, cu o temperatură compatibilă cu debitul de apă din sistem către cazan.
- Așteptați ca pe afișaj să fie prezent simbolul flăcării.



- Accesați parametri (consultați procedura indicată în capitolul 10 „Setare parolă, acces și modificare parametri”).
- Selectați meniul **P2** folosind tastele **C** sau **D** și confirmați cu tasta **A**.
- Selectați parametrul P206 folosind tastele **C** sau **D** și confirmați cu tasta **A**.
Notă: parametrul nu este disponibil în lipsa solicitării de căldură.
- Setări P206 = 1 cu tasta **C** pentru a activa funcția GAC.

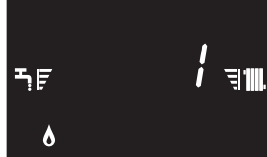

Afișajul prezintă textul GAC care se aprinde intermitent și începe o fază de așteptare de aprox. 1 minut, după care, începe calibrarea. În timpul acestei faze, textul „GAC” se aprinde intermitent, alternând cu numărul de rotații ale ventilatorului, cu o durată de aprox. 2-5 minute.



În această fază, nicio tastă nu trebuie să fie acționată până la apariția textului „END” (cu P105 = 1 text derulant --> FUNCȚIA OPRIRE ÎN CURS), care indică faptul că procedura este finalizată corect.

- ⚠ Dacă procedura GAC nu continuă, iar după confirmare valoarea 1 rămâne afișată (procedura nu afișează mesajul GAC), este foarte probabil că sistemul electronic să efectueze un control al arderii. În acest caz, așteptați câteva minute și verificați dacă sistemul continuă automat. Dacă situația persistă, efectuați eventual o OPRIRE TOTALĂ (POWER OFF) a centralei și relansați procedura GAC conform instrucțiunilor.



La finalizarea funcției, parametrul revine automat la 0.



Dacă procedura GAC nu este finalizată, sistemul permite executarea unei reîncercări GAC care este indicată pe afișaj cu „RTY” și apoi continuă prin apăsarea tastei **B**.



NOTĂ: Dacă nu este posibilă dispariția căldurii în apa caldă menajeră, este totuși posibilă, pentru sistemele cu temperatură înaltă, să se efectueze GAC la cererea de încălzire, setând valoarea de referință a apei de încălzire la 80,5°C sau chiar mai bine, activând analiza arderii și ulterior, cu flacăra aprinsă, porniți GAC-ul.

Odată terminată procedura, apăsați tasta **B** de 3 ori pentru a reveni la ecranul principal.

Dacă procedura nu este efectuată atunci când este obligatoriu, o astfel de nerespectare a obligației poate conduce la o funcționare limitată și posibilitatea să se manifeste semnalizări de eroare asociate controlului arderii.

Dacă apare o defecțiune în timpul procedurii sau dacă cererea de căldură este întreruptă, procedura ar fi întreruptă prematur, prezentându-se tarea de eroare sau trecând automat la ecranul principal. În acest caz, procedura ar fi repetată.

5.5 Setarea termoreglării

Termoreglarea este disponibilă numai cu sonda externă conectată și activă, numai pentru funcția ÎNCĂLZIRE.

Pentru activarea TERMOREGLĂRII procedați în felul următor:

- accesați parametrul **P4** → P418 = 1.

Cu P418 = 0 sau sondă externă deconectată, centrala **funcționează într-un punct fix**.

Valoarea temperaturii detectată de sonda externă este vizualizată în "6.3 Meniu INFO" în elementul I009.

Algoritmul de termoreglare nu va utiliza direct valoarea temperaturii externe măsurată, ci o valoare mediată a temperaturii externe, care ține cont de izolația clădirii: la clădirile bine izolate, variațiile temperaturii externe influențează mai puțin temperatura mediului față de imobilele insuficient izolate.

Această valoare poate fi vizualizată în meniul INFO în elementul I010.

SOLICITARE DE LA CRONOTERMOSTATUL OT

În acest caz, valoarea de referință de tur este calculată de cronotermostat în funcție de valoarea temperaturii externe și de diferența dintre temperatura ambiantă și temperatura ambiantă dorită.

SOLICITARE DE LA TERMOSTATUL DE TEMPERATURĂ AMBIANTĂ

În acest caz, valoarea de referință de tur este calculată de placa de reglare în funcție de valoarea temperaturii externe pentru a obține o valoare estimată a temperaturii ambiante de 20°C (temperatura ambiantă de referință). Sunt 2 parametri care contribuie la calculul punctului de referință de tur:

- înclinarea curbei de compensare (KT) - modificabilă de către personalul tehnic
- compensarea temperaturii mediului de referință - modificabilă de către utilizator.

TIP CLĂDIRE (parametru P433)

Este indicativul frecvenței cu care este actualizată valoarea temperaturii externe calculate pentru termoreglare; o valoare scăzută va fi utilizată pentru clădirile insuficient izolate.

REAȚIA SONDEI EXTERNE (parametru P434)

Este indicativul vitezei cu care variațiile valorii temperaturii externe măsurate influențează valoarea temperaturii externe calculată pentru termoreglare; valorile scăzute arată viteze ridicate.

Selectarea curbei de termoreglare (parametru P419)

Curba de termoreglare de încălzire menține o temperatură teoretică de 20 °C în mediul ambiant la temperaturi exterioare cuprinse între +20 °C și -20 °C. Alegerea curbei depinde de temperatura exterioară minimă de proiectare (așadar și de așezarea geografică) și de temperatura de alimentare proiectată (așadar și de tipul de instalație) și trebuie calculată cu atenție de către instalator, după formula următoare:

$$KT = \frac{T_{\text{tur proiect}} - T_{\text{shift}}}{20 - T_{\text{externă min. proiect}}}$$

Tshift = 30 °C, instalații standard

25°C, instalații de încălzire în pardoseală

Dacă din calcul reiese o valoare intermediară între două curbe, se recomandă să alegeți curba de termoreglare cea mai apropiată de valoarea obținută.

Exemplu: dacă valoarea obținută din calcul este 1.3, aceasta se găsește între curba 1 și curba 1.5. În acest caz, alegeți curba cea mai apropiată, adică 1.5. Valorile KT care pot fi configurate sunt următoarele:

- instalație standard: 1,0÷3,0
- instalație de încălzire în pardoseală 0,2÷0,8.

Cu parametrul P419 setați curba de termoreglare preselectată:

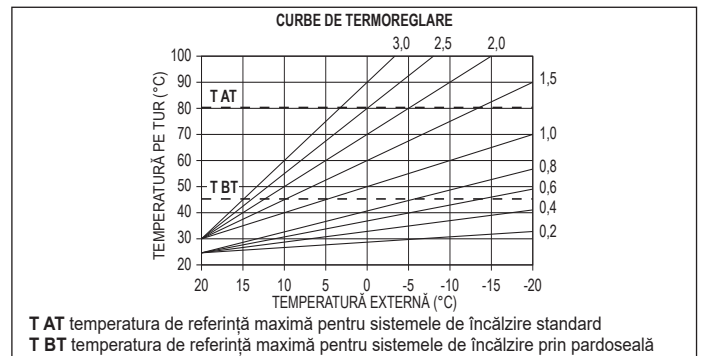

Compensarea temperaturii ambiante de referință

Utilizatorul poate interveni indirect asupra valorii punctului de referință ÎNCĂLZIRE, setând, la valoarea temperaturii de referință (20°C), o compensare care poate varia în intervalul -5÷+5 (compensare 0 = 20°C). Pentru corecția compensării, consultați paragraful "8.4 Setare valoare de referință de încălzire cu sondă externă".

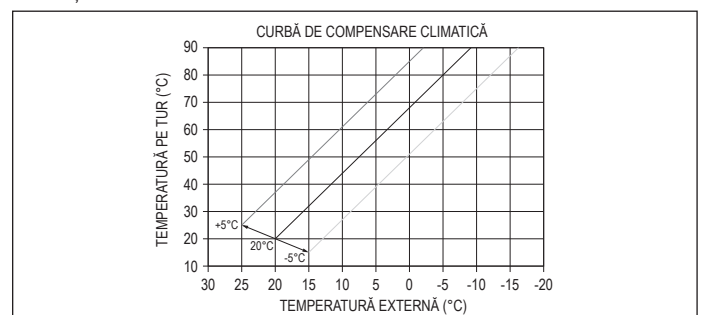

COMPENSARE NOCTURNĂ (parametrul P420)

Dacă la intrarea TERMOSTATULUI de AMBIENT este conectat un programator orar, din parametrul P420 poate fi activată compensarea nocturnă: setați parametrul P420 = 1.

În acest caz, atunci când CONTACTUL este ÎNCHIS, cererea de căldură este lansată de sonda de tur, pe baza temperaturii externe, pentru a avea o temperatură nominală în mediu la nivelul de ZI (20 °C). DESCHIDEREA CONTACTULUI nu determină oprirea centralei, ci o reducere (translație paralelă) a curbei climatice pe nivelul NOAPTE (16 °C).

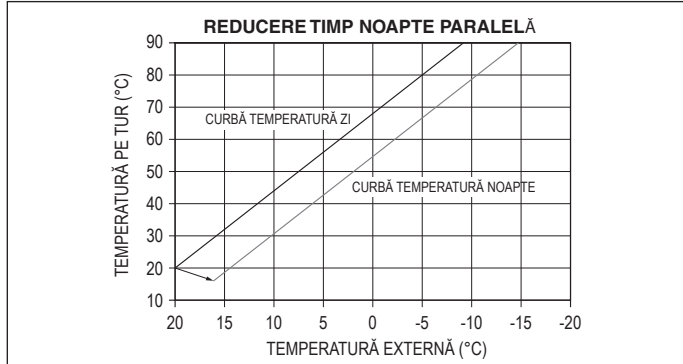

Utilizatorul poate interveni indirect asupra valorii punctului de referință ÎNCĂLZIRE, introducând încă o dată, mai curând la valoarea temperaturii de referință de ZI (20°C) decât la cea de NOAPTE (16°C), o compensare care poate varia în intervalul [-5 ÷ +5]. COMPENSAREA NOCTURNĂ nu este disponibilă dacă este conectat cronotermostatul OT+. **Pentru corecția compensării, consultați paragraful "8.3 Setare valoare de referință de încălzire".**

5.6 Funcția „Confort apă menajeră”

Cazanul include inițial FUNCȚII "CONFORT APĂ MENAJERĂ", care, totuși, în combinație cu un DOSSERET, este preferabil să nu fie activată deoarece REZERVORUL DOSSERET îndeplinește aceste scopuri.

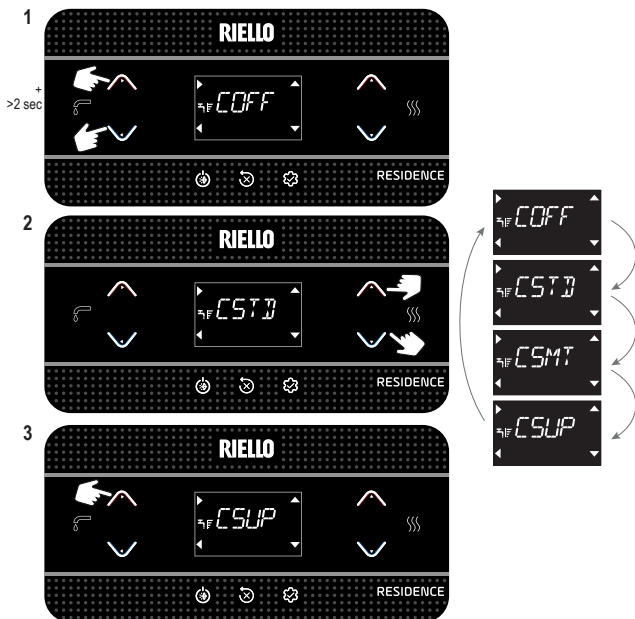

Funcție	Mesaj derulabil
COFF	CONFORT DEZACTIVAT
CSTD	CONFORT PREINCALZIRE
CSMT	CONFORT TOUCH GO
CSUP	CONFORT PREÎNCĂLZIRE INTELIGENTĂ

CSTD (funcție PREÎNCĂLZIRE): dacă se setează CSTD, se activează funcția de preîncălzire a apei calde menajere a centralei. Această funcție permite menținerea temperaturii apei calde din schimbătorul pentru apă menajeră, cu scopul de a reduce timpul de așteptare în timpul utilizării apei. Când funcția de preîncălzire este activată, pe ecran apare PRH (cu P105 = 1 text derulant --> FUNCTIE PREINCALZIRE ACTIVA). Pentru a dezactiva funcția de preîncălzire, setați COFF. Funcția nu este activă dacă centrala se află în starea OFF (oprită).

CSMT (funcția TOUCH & GO): dacă nu doriți să lăsați funcția de PREÎNCĂLZIRE activă mereu și dacă este nevoie de apă caldă gata imediat, se poate efectua preîncălzirea apei menajere cu câteva momente înainte de preluare. Setati CSMT pentru a activa funcția Touch&Go. Această funcție permite, deschizând și închizând robinetul, activarea preîncălzirii instantanee, ce pregătește apa caldă doar pentru acea preluare. Când funcția Touch&Go

este activată, pe ecran apare T-G (cu P105 = 1 text derulant --> FUNCTIE TOUCH GO ACTIVA).

CSUP (funcție de preîncălzire SMART): când funcția este activă, post-circulația pentru finalizarea solicitării de încălzire are loc cu trei căi poziționate la nivelul apei menajere până când una dintre următoarele condiții este îndeplinită:

- ΔT (sondă tur - retur) < 2 °C
- Durata postcirculare > 20 sec
- Temperatura apei la retur > 65 °C.

Când funcția este activată, pe ecran apare PRHS (cu P105 = 1 text derulant --> PREÎNCĂLZIRE INTELIGENTĂ ACTIVĂ).

5.7 Funcții speciale apă menajeră

Cazanul include inițial FUNCȚII "SPECIALE APĂ MENAJERĂ", care, totuși, în combinație cu un DOSSERET, este preferabil să nu fie activată deoarece REZERVORUL DOSSERET îndeplinește aceste scopuri.

Parametrul P511 permite activarea funcțiilor speciale în timpul fazei de modulare a apei menajere, aceste funcții permit îmbunătățirea performanțelor centralei în condiții de funcționare dificile (exemplu, temperaturi ale apei ridicate la intrare, debite foarte joase, utilizare în combinație cu boilere solare).

0	Nicio funcție specială activă (valoare implicită)
1	Introducere privind întârzierea pornirii fluxostatului/debitmetrului (parametrul P510 - SERVICE)
2	În cazul opririi din cauza supratemperaturii apei calde menajere (cu preluare în curs), ventilatorul este menținut la minim pentru a reduce timpul de așteptare pentru repornire.
3	Termostate absolute pentru apă menajeră
4	Funcție apă caldă menajeră smart antioscilații
5	Toate cele patru funcții active precedente

Funcția ÎNTĂRZIERE APĂ CALDĂ MENAJERĂ (1): prin activarea acestei funcții, este introdusă o întârziere egală cu valoarea setată în parametru P510, la activarea pompei și ventilatorului ca răspuns la o solicitare de încălzire pentru apă menajeră.

Funcția VENTILATOR SMART (2): prin activarea acestei funcții, ventilatorul este menținut la minim (MIN) și nu este oprit în caz de dezactivare a arzătorului din cauza supratemperaturii apei calde menajere (cu solicitare încă prezentă).

Funcția TERMOSTATE ABSOLUTE (3): prin activarea acestei funcții, termostatele pentru apă menajeră de ACTIVARE/DEZACTIVARE a arzătorului trec de la valoarea relativă la cea absolută.

Funcția ANTIOSCILAȚII (4): prin activarea acestei funcții, centrala se configurează automat la TERMOSTATE ABSOLUTE în caz de dezactivare a arzătorului din cauza supratemperaturii apei calde menajere (cu solicitare în curs); când arzătorul este oprit, ventilatorul este menținut la minim. Termostatele trec în starea „CORELATE” la finalul preluării.

5.8 Funcție de încălzire a zonei inițiale

Dacă instalația este de temperatură joasă, centrala prevede o funcție de „încălzire șapă” care poate fi activată în modul următor:

- setați centrala în starea de DEZACTIVARE apăsând pe tasta (funcție disponibilă doar în această stare de funcționare)



- accesați parametrii tehnici --> P4 --> P409 = 1 --> confirmați; Pe afișaj este prezentat (cu P105 = 1 text derulant --> FUNCTIE USCARE ȘAPĂACTIVA):

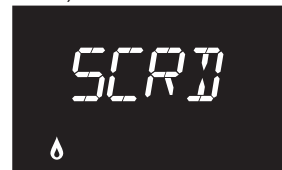

Funcția de „încălzire șapă” are o durată de 168 de ore (7 zile), timp în care, în zonele configurate de temperatură joasă, este simulată o cerere de căldură cu punctul de referință de tur pentru zona inițială egal cu 20°C, dar care crește treptat conform următorului tabel.

Accesând meniul INFO de pe ecranul principal al interfeței puteți vizualiza valoarea de I001, care indică numărul de ore trecute din momentul în care a fost activată funcția. Odată activată, funcția are prioritate maximă; dacă aparatul este decuplat de la sursa de alimentare electrică și este oprit, atunci când este repornit funcția este reluată de unde a fost întreruptă. Funcția poate fi întreruptă înainte de final, aducând aparatul într-o stare diferită de DEZACTIVARE sau selectând elementul P409=0 FUNCȚIE din meniul P4.

ZI	ORĂ	TEMPERATURĂ
1	0	20°C
	6	22°C
	12	24°C
2	0	26°C
	12	28°C
	18	30°C
3	0	32°C
	6	35°C
	12	35°C
4	0	30°C
	6	35°C
	12	25°C

Observație: Valorile temperaturii și de creștere a acesteia pot fi modificate doar de personal calificat, numai dacă este absolut necesar. Fabricantul nu își asumă nicio responsabilitate în cazul unor setări greșite ale parametrilor. În meniul INFO, pe rândul I001 se poate vedea numărul de ore care au trecut de la activarea funcției.

5.9 Controale în timpul și după prima punere în funcțiune

La punerea în funcțiune, verificați dacă centrala efectuează în mod corect procedurile de pornire și, ulterior, de stingere.

- Verificați și funcționarea în modul de apă menajeră deschizând un robinet de apă caldă cu starea centralei în modul pentru VARĂ sau în modul pentru IARNĂ.
- Verificați oprirea totală a centralei prin aducerea întrerupătorului general al instalației în poziția de oprire.
- După câteva minute de funcționare continuă, care se obține prin aducerea întrerupătorului general al instalației în poziția „pornit”, setând starea centralei pe Vară și menținând deschis circuitul de apă menajeră, lianții și reziduurile de prelucrare se evaporă și abia mai târziu vei putea efectua verificarea arderii.

5.10 Verificarea arderii



Verificările reglementărilor privind valorile CO₂ referitor la parametrii de referință, indicați în tabelele de mai jos, trebuie să fie realizate cu carcasa închisă.

Pentru a efectua verificarea arderii, acționați în felul următor:

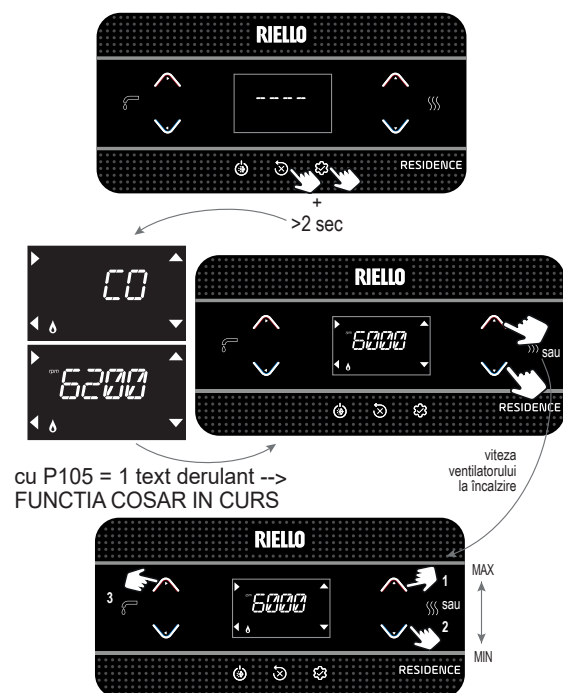
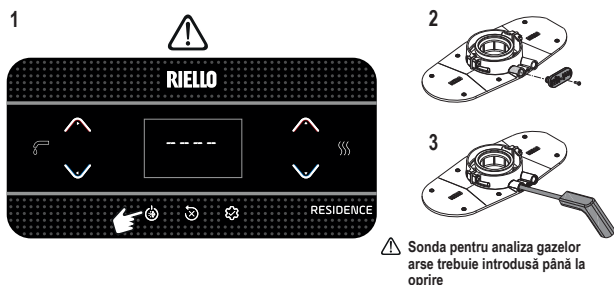

- Afișajul prezintă timp de 10 sec numărul de turații setat, alături de simbolul rpm.
- Setând valoarea maximă, centrala va funcționa la capacitate maximă; Setând valoarea minimă, centrala va funcționa la capacitate minimă.



- Verificați pe analizor dacă valorile CO₂ max și min sunt în conformitate cu cele indicate în tabelele următoare.

CO ₂ * max		GAZ METAN (G20)	GAZ LICHID (G31)	
	25BIS	8,8	10,0	%
	35BIS	8,8	9,9	%
(*) toleranta CO ₂ = ±1%				

CO ₂ * min		GAZ METAN (G20)	GAZ LICHID (G31)	
	25BIS	8,8	10,0	%
	35BIS	8,8	10,0	%
(*) toleranta CO ₂ = ±1%				

- Asigurați-vă că valorile O₂ (max, nominal și min) asociate unui amestec de 20% hidrogen sunt în conformitate cu cele indicate în cele ce urmează.

Valoarea O ₂ asociată combinației 20% hidrogen	Qmax			25BIS	35BIS
		max	%	2,4	2,4
		nominal	%	4,3	4,3
	min	%	6,2	6,2	
	Qmin	max	%	2,4	2,4
		nominal	%	4,3	4,3
min		%	6,2	6,2	

- Funcția COȘAR are o durată maximă de 15 minute; Se poate întrerupe oricând procedura în mod anticipat, apăsând pe tasta B.
- Dacă echipamentul are o temperatură joasă, în mod direct, fără supapă de amestecare sau termostatică, funcția COȘAR este efectuată la solicitarea de apă menajeră.



Funcția COȘAR este întreruptă prematur dacă:

- temperatura de tur depășește 95°C; repornirea va avea loc atunci când această temperatură coboară sub 75°C
- Nu este detectată flacăra cu alarmele rezultante
- În caz de alarmă.



Cu dispozitivul OT+ conectat, nu este posibilă activarea funcției de control al arderii. Pentru a efectua analiza gazelor arse, setați la 0 valoarea parametrului P803. Nu uitați să restabiliți valoarea parametrului pentru a reactiva conexiunea OT+ pentru analiza gazelor arse.

La finalizarea verificării:

- părăsiți funcția apăsând pe tasta B
- scoateți sonda analizorului și închideți prizele pentru analiza arderii cu capacele aferente și șurubul corespunzător
- Puneți la loc și păstrați adaptorul pentru sonda de analiză din dotarea centralei în plicul documentației
- setați centrala pe modul de funcționare dorit în funcție de anotimp
- reglați valorile de temperatură conform cerințelor clientului.

5.11 Reglaje

Cazanul a fost deja reglat în timpul producției de către producător. Totuși, dacă este necesar să se efectueze din nou reglajele (de exemplu după întreținere extraordinară, după înlocuirea supapei de gaz, după o transformare a gazului sau după înlocuirea plăcii) urmați procedurile descrise mai jos.

Puterea maximă și minimă și reglajele maxime de încălzire trebuie efectuate numai de personal calificat:

P306	Viteză de rotație minimă a ventilatorului
P307	Viteză de rotație maximă a ventilatorului
P309	Viteză de rotație maximă a ventilatorului de încălzire

- alimentați centrala
- accesați parametrii tehnici → P3 → confirmați → selectați parametrul relevant → confirmați
- setați valorile dorite cu tastele C și/sau D, consultând tabelele următoare
- asigurați-vă că P309= P310.



Viteza maximă a ventilatorului de încălzire utilizată va fi cea setată în parametrul P310.

NUMĂR MAXIM DE ROTAȚII VENTILATOR	GAZ METAN (G20)	GAZ LICHID (G31)	
25BIS încălzire - ACM	6.300 - 7.900	6.100 - 7.600	rpm
35BIS încălzire - ACM	7.400 - 8.600	7.100 - 8.200	rpm

NUMĂR MINIM DE ROTAȚII VENTILATOR	GAZ METAN (G20)	GAZ LICHID (G31)	
25BIS	1.200	1.250	rpm
35BIS	1.300	1.250	rpm

5.12 Transformarea tipului de gaz

Centrala este furnizată pentru funcționarea cu gaz metan (G20), conform datelor indicate pe plăcuța tehnică a produsului. Există posibilitatea de a transforma centrala cu GPL (G31) prin intermediul parametrului P201.

⚠ Conversia de la un tip de gaz la altul este simplă și se poate face și cu centrala instalată.

⚠ Această operațiune trebuie să fie efectuată de personal calificat.

- Accesați parametri tehnici → **P2** → P201 → confirmați.

- Folosiți tasta **C** sau **D** pentru a selecta opțiunea dorită:

P201 = 1 (NG)

P201 = 2 (LPG)

P201 = 3

P201 = 4

⚠ Confirmați modificarea parametrului cu **ENTER**, ulterior întrerupeți tensiunea de la nivelul centralei pentru cel puțin 10 secunde.

După modificarea parametrului GAZ, este necesară efectuarea unei noi proceduri „GAC” (consultați cap. 5.4), verificați dacă turațiile ventilatorului corespund celor indicate în tabelele 1 și 2, cap. 5.11.

5.13 Verificarea presiunii de alimentare cu gaz

Pentru a verifica presiunea de alimentare cu gaz:

- închideți robinetul de oprire a gazului de la intrarea în centrală
- slăbiți șurubul priză de presiune din amonte de supapa de gaz și conectați furtunul de legătură la manometru
- deschideți robinetul de oprire a gazului de la intrarea în centrală
- activați funcția COȘAR
- valoarea corectă a presiunii pentru fiecare tip de gaz este indicată în tabelul „Date tehnice”
- după efectuarea verificării, opriți funcția COȘAR
- închideți robinetul de oprire a gazului de la intrarea în centrală
- deconectați furtunul de legătură de la manometru și strângeți etanș șurubul priză de presiune din amonte de supapa de gaz
- deschideți robinetul de oprire a gazului de la intrarea în centrală.

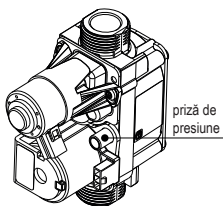

⚠ Nestrângerea șurubului priză de presiune poate provoca scurgeri de gaz combustibil.

⚠ După orice intervenție asupra circuitului de gaz sau aer/gaz, efectuați o verificare de etanșeitate.

5.14 Semnalizări și anomalii

În cazul unei anomalii, pictograma se aprinde intermitent cu o frecvență de 0,5 sec ACTIVATĂ și 0,5 sec DEZACTIVATĂ, retroiluminatul se aprinde timp de 1 min cu o frecvență de 1 sec ACTIVATĂ și 1 sec DEZACTIVATĂ, după care se stinge, în timp ce semnalul sonor continuă să se audă. Pe afișajul cu 4 cifre, apare codul de eroare.

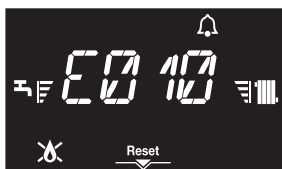

La apariția unei anomalii, pot apărea următoarele pictograme:

- se aprinde în cazul unei alarme de flacără (E010)
- **RESET** se aprinde în prezența unei alarme ce impune deblocarea manuală din partea utilizatorului (exemplu de blocare flacără)
- se aprinde împreună cu pictograma , excluzând anomaliile de blocare flacără și lipsă apă
- se aprinde în prezența unor alarme sau semnalizări asociate presiunii apei; în acest caz, valoarea presiunii apei este afișată în mod alternativ cu codul de anomalie la fiecare 3 secunde.

Funcție de deblocare

Pentru a restabili funcționarea centralei în cazul unei anomalii, este necesară acționarea tastei **RESET**.



În acest moment, dacă au fost restabilite condițiile pentru funcționarea corectă, centrala repornește automat. Sunt posibile până la maximum 5 încercări consecutive de deblocare a aceleiași alarme de pe interfață, după care pe afișaj apare codul de eroare E099.

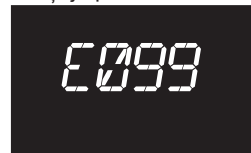

În acest caz, este necesară întreruperea și reluarea alimentării cu energie electrică la nivelul centralei pentru a reporni funcționarea.

⚠ Dacă încercările de restabilire nu vor activa funcționarea centralei, contactați Serviciul Tehnic de Asistență.

Anomalie E041

Dacă valoarea presiunii scade sub valoarea de siguranță de 0,3 bar, centrala afișează codul de eroare E041 pentru un interval scurt de timp de 10 min.

Dacă a trecut timpul de tranziție și anomalia persistă, este afișat codul de anomalie E040.

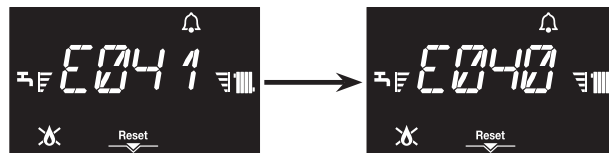

Atunci când centrala prezintă eroarea E040, este necesar:

- să deschideți robinetul de umplere (A) rotindu-l spre stânga
- să verificați dacă valoarea presiunii atinge 1-1,5 bar prin intermediul hidrometrului amplasat sub consola sau accedând meniul INFO ("6.3 Meniu INFO", rândul I018)
- să închideți robinetul de umplere (A) asigurându-vă că auziți un sunet mecanic.

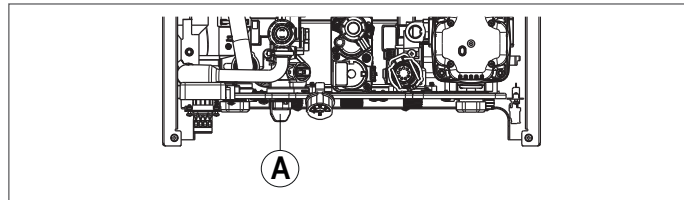

Apăsați pe pentru a relua funcționarea.

După reluarea funcționării, centrala efectuează un ciclu de purjare automat conform celor descrise în paragraful "4.10 Umplerea sistemului de încălzire și eliminare a aerului".

⚠ În cazul în care căderea de presiune este foarte frecventă, solicitați intervenția Serviciului Tehnic de Asistență.

Eroarea E060

Centrala funcționează normal, dar nu asigură stabilitatea temperaturii apei menajere, care, oricum, este furnizată la o temperatură de aproape 50 °C. Este necesară intervenția Serviciului Tehnic de Asistență.

Anomalie E091

Centrala dispune de un sistem de autodiagnostic care, pe baza orelor totalizate în condiții speciale de funcționare, poate să semnaleze necesitatea de intervenție pentru curățarea schimbătorului principal (cod alarmă E091).

După terminarea operațiunii de curățare, efectuată cu kitul corespunzător furnizat ca accesoriu, trebuie să aduceți la zero contorul numărului total de ore, aplicând următoarea procedură:

- accesați parametrii tehnici → **P3** → P312 → P312 = 1 → confirmați.

OBSERVAȚIE: Procedura de resetare a contorului trebuie efectuată după fiecare curățare atentă a schimbătorului principal sau în cazul înlocuirii acestuia.

Eroarea E091 se manifestă când contorul depășește valoarea de 2500 ore; această valoare poate fi verificată în următorul mod:

- accesați meniul INFO → I015 pentru a vizualiza valoarea contorului pentru sondă gaze arse (vizualizare/100, exemplu 2.500h = 25).

Anomaliile E035-E036: Prezența unei notificări de alarmă cu codul E035 sau E036, care necesită resetarea prin butonul central, poate fi normală în anumite condiții de mediu. Dacă notificarea nu apare frecvent, efectuați resetarea alarmei fără a fi necesară intervenția tehnică.

COD DE EROARE	MESAJ DE EROARE	DESCRIEREA TIPULUI DE ALARMĂ	
E010	BLOCARE FLACARA	DEFINITIVE	
E011	FLACARA PARAZIT		
E012	NUMĂR MAXIM DE PIERDERI DE FLACĂRĂ		
E013	TESTUL HARDWARE A EȘUAT		
E014	TESTUL DE DETECȚIE A FLĂCĂRII A EȘUAT		
E015	TESTUL DE TENSIUNE DE DETECTARE A FLĂCĂRII A EȘUAT		
E020	TERMOSTAT DE LIMITA		
E021	FUNȚIONARE DEFECTUOASĂ A COMENZII VANEI DE GAZ		
E030	ANOMALIE VENTILATOR		
E031	ROTOR VENTILATOR BLOCAT MECANIC		
E032	ROTOR VENTILATOR BLOCAT		
E033	ROTOR VENTILATOR DETERIORAT		
E034	OBSTRUCȚIE A COȘULUI DE FUM ÎN PREVENTILARE		
E035	BLOCAT OBSTRUCȚIE GAZE DE ARDERE LA PUTERE REDUSĂ		
E036	BLOCAT OBSTRUCȚIE GAZE DE ARDERE LA PUTERE MARE		
E037	VERIFICAREA COMBUSTIEI A EȘUAT LA PUTERE REDUSĂ		
E038	VERIFICAREA COMBUSTIEI A EȘUAT LA PUTERE MARE		
E039	VALOARE ANORMALĂ A FLĂCĂRII		
E040 + valoare bari	UMPLETI INSTALATIA		
E042	ANOMALIE TRADUCTOR PRESIUNE		
E071	SUPRATERMPERATURA SONDA TUR		
E072	DIFERENȚIAL TUR - RETUR		
E075	LIMITA DE DESCHIDERE A VANEI A FOST ATINSĂ		
E088	ALARMĂ REZERVATĂ		
E092	CALIBRARE EȘUATĂ, NUMĂR EXCESIV DE CALIBRĂRI ÎNTR-O ORĂ.		
E093	CALIBRARE EȘUATĂ, PEA MULTE ÎNCERCĂRI DE CALIBRARE NEREUȘITE		
E094	LAMBDA PESTE LIMITĂ		
E097	VERIFICAREA EȘUATĂ (a fost detectat un nivel incorect de combustie)		
E098	A FOST DETECTAT UN NIVEL INCORECT DE ARDERE		
E099	TENTATIVE RESET EFECTUATE		
E041 + valoare bari	UMPLETI INSTALATIA		TRANZITORII
E050	EROARE OBSTRUCȚIE GAZE DE ARDERE LA PUTERE REDUSĂ		
E051	CONSECINȚA UNEI CALIBRĂRI EFECTUATE ÎNTR-UN REGIM DE INSTABILITATE A FLĂCĂRII/OBSTRUCȚIE		
E052	EROARE HARDWARE ÎN AFARA LIMITEI		
E055	LIPSĂ COMUNICARE CU PLACA VENTILATORULUI		
E056	LIPSĂ COMUNICARE MICROPROCESOR PLACĂ		
E060	ANOMALIE SONDA ACM		
E070	ANOMALIE SONDA TUR		
E071	SUPRATERMPERATURA SONDA TUR		
E072	DIFERENȚIAL TUR - RETUR		
E077	TERMOSTAT APA ZONA PRINCIPALA		
E080	ANOMALIE SONDA RETUR		
E081	SUPRATERMPERATURA SONDA RETUR		
E082	DIFERENȚIAL RETUR - TUR		
E090	ANOMALIE SONDA GAZE ARSE		
E091	CURATATI SCHIMBATORUL PRIMAR		
E095	CALIBRARE EȘUATĂ		
E096	LAMBDA PESTE LIMITĂ		
FIL + valoare în bari	PRESIUNE SCAZUTA VERIFICATI INSTALATIA	SEMNALIZARE	
 ce luminează intermitent + valoare în bari	PRESIUNE RIDICATA VERIFICATI INSTALATIA		
COM	COMUNICATIE PIERDUTA PLACA ELECTRONICA (mai mult de 30 secunde)	SEMNALIZARE: (unitatea de încălzire continuă să funcționeze dar fără afișaj și taste)	
E066	DOSERET COMUNICARE PIERDUT	SEMNALIZARE	
FWER	VERSIUNE SW INCOMPATIBILA	SEMNALIZARE: (unitatea de încălzire continuă să funcționeze dar fără afișaj și taste)	
CFS	APELATI SERVICE	SEMNALIZARE	
SFS	OPRITI PENTRU SERVICE	DEFINITIVĂ	
OBCD	UNITATEA DE CEAS DETERIORATA	SEMNALIZARE: (unitatea de încălzire continuă să funcționeze dar fără afișaj și taste)	

5.15 Înlocuirea supapei de gaz (P205)

După înlocuirea supapei de gaz, este necesar să resetați valoarea **P1** a acesteia (consultați imaginea), în acest caz, urmați această procedură:

- setați centrala în stare DEZACTIVATĂ
- accesați parametri setând parola conform celor indicate în capitolul 10 „Setare parolă, acces și modificare parametri”
- cu tastele **C** sau **D** accesați parametrul **P2** → P205 și confirmați selecția cu tasta **A**
- cu tastele **C** sau **D**, introduceți a doua și a treia cifră a valorii **P1** (adică **034** devine **34**) scrise pe robinetul de gaz din cazan (fiecare supapă de gaz are propria sa valoare offset **P1**), confirmați cu tasta **3**
- întrerupeți alimentarea centralei timp de cel puțin 10 secunde; apoi reporniți alimentarea electrică.

După finalizarea înlocuirii, efectuați o nouă procedură de „GAC” (vezi cap. 5.4).



Dacă supapa de gaz este înlocuită, înlocuiți și garniturile de etanșare aferente.

Pentru a strânge piulița rampei supapei de gaz, aplicați un cuplu egal cu 25 Nm, limitând rotația supapei.



5.16 Înlocuire interfață

Operațiunile de configurare a sistemului trebuie făcute de personal calificat profesional de la Serviciul de asistență tehnică. În cazul înlocuirii plăcii de interfață, power on (activarea) ar putea fi necesară pentru utilizator pentru a reseta valorile de oră și zi din săptămână (consultați "5.2 Prima punere în funcțiune"); verificați în plus și resetați, dacă este necesar, informațiile asociate programării orare pentru încălzire și apă caldă menajeră (consultați "8.1 Funcția program orar (termostat de ambient)") și funcției Biberon (consultați "8.12 Funcție BIBERON"); rețineți că nu este necesară reprogramarea parametrilor de configurare, a căror valoare este preluată de la placa de reglare și control prezentă în centrală. Ar putea fi necesară, în schimb, resetarea valorilor de referință pentru apa caldă menajeră și/sau încălzire.

5.17 Înlocuire placă

Dacă cazul plăcii de comandă este o procedură de înlocuire și reglare, poate fi necesară verificarea parametrilor de configurare și eventual reconfigurarea acestora. Consultați tabelul de parametri pentru a identifica valorile implicite ale plăcii, valorile setate din fabrică și cele personalizate. Parametrii care trebuie neapărat verificați și eventual resetați sunt: P201 • P205 (cu cazanul oprit) • P208 • P301 • P302 (SERVICE) • P306 • P307 • P309 • P310. Întrerupeți alimentarea centralei timp de cel puțin 10 secunde; apoi reporniți alimentarea electrică. După finalizarea înlocuirii, efectuați o nouă procedură de „GAC” (vezi cap. 5.4).

6 ÎNTREȚINERE ȘI CURĂȚENIE

 *Întreținerea periodică este o „obligație” prevăzută de normele în vigoare și este esențială pentru siguranța, randamentul și durata de viață a centralei. Aceasta permite reducerea consumurilor, emisiilor poluante și menținerea produsului sigur și fiabil în timp.*

Întreținerea centralei trebuie să fie efectuată cel puțin o dată pe an, programând-o din timp la echipa de asistență tehnică.

Înainte de a începe operațiunile de întreținere:

- Închideți robinetele de carburant și de apă ale instalației de încălzire și de apă menajeră.

Pentru a garanta menținerea caracteristicilor aparatului din punctul de vedere al eficienței și funcționalității, precum și pentru a respecta dispozițiile legilor în vigoare, este necesar să executați operațiunile de întreținere la intervale regulate de timp. Pentru întreținere, respectați indicațiile din capitolul "1 AVERTISMENTE ȘI MĂSURI DE SIGURANȚĂ".

De regulă, se efectuează următoarele operațiuni:

- îndepărtarea eventualelor reziduuri de ardere provenite de la arzător;
- îndepărtarea eventualelor depuneri de pe schimbătoare;
- verificarea stării de deteriorare a electrozilor și, dacă aceștia sunt deteriorați, înlocuirea acestora împreună cu garnitura de etanșeitate corespunzătoare;
- verificarea și curățarea generală a conductelor de evacuare și aspirație;
- controlul aspectului exterior al centralei;
- controlul pornirii, opririi și funcționării centralei, atât în modul de pregătire a apei calde menajere, cât și în cel de încălzire;
- controlul etanșeității racordurilor și conductelor de conectare la rețeaua de alimentare cu gaz și apă și condens;
- controlul consumului de gaz la putere maximă și minimă;
- dacă presiunea apei menajere este inferioară valorii de 3 bar, evacuați circuitul de apă menajeră al centralei și asigurați întreținerea presiunii în circuitul de încălzire;
- verificarea integrității izolației cablurilor electrice, în special în apropierea schimbătorului principal;
- verificarea siguranței de detectare a lipsei gazului;
- verificarea și curățarea sifonului;
- verificarea curățenii ventilatorului, extracție internă (inclusiv filtrul de aer atunci când este prevăzut);
- **verificarea prezenței apei în sifon; în caz contrar, se asigură umplerea cu apă.**

 Placa electronică și supapa de gaz nu necesită o verificare specifică care să evalueze îmbătrânirea și deteriorarea.

 În faza de întreținere a centralei, se recomandă să utilizați echipamente de protecție pentru a evita accidentările personale.

 După ce ați realizat operațiunile de întreținere, trebuie efectuată analiza produsilor de ardere pentru a verifica funcționarea corectă.

 Nu curățați centrala sau componentele sale cu substanțe ușor inflamabile (de exemplu, benzină, alcool etc.).

 Nu curățați panourile, componentele vopsite sau din plastic cu diluanți pentru vopsele.

 Curățarea panourilor se va face numai cu apă cu săpun.

Efectuați o nouă procedură "GAR", apoi scoateți alimentarea pentru cel puțin 10 secunde și, în final, efectuați o nouă procedură "GAC" (vezi par. 5.4), în următoarele cazuri:

- modificarea conductei de admisie și evacuare
- curățarea schimbătorului primar
- înlocuirea electrozilor de aprindere și detectare a flăcării
- înlocuirea schimbătorului primar și/sau a transportorului.

Efectuați o nouă procedură "GAR", apoi scoateți alimentarea pentru cel puțin 10 secunde și, în final, efectuați o nouă procedură "GAC" (vezi par. 5.4) doar dacă o analiză a produselor de combustie este în afara toleranței în următoarele cazuri:

- curățarea arzătorului
- curățarea transportorului
- curățarea ventilatorului
- înlocuirea/curățarea mixerului ventilatorului.

Curățare schimbător principal

- Întrerupeți alimentarea cu energie electrică, poziționând întrerupătorul general al instalației pe „oprit”.
- Închideți robinetii de interceptare a gazului.
- Scoateți carcasa conform celor indicate în paragraful "4.7 Demontarea carcasei”.
- Deconectați cablul de conexiune al electrozilor de aprindere și de detectare.
- Deconectați cablurile de alimentare ale ventilatorului.
- Desfaceți de pe mixer clema de fixare a rampei.
- Slăbiți piulița rampei de gaz.
- Desfaceți rampa de gaz de pe mixer și rotiți-o.
- Desfaceți cele 4 piulițe care fixează grupul de combustie.
- Extrageți ansamblul transportorului aer/gaz ce include ventilatorul și mixerul, procedând cu atenție pentru a nu deteriora panoul de izolare și electrodul.
- Demontați de la racordul de evacuare condens al schimbătorului tubul de conectare sifon și racordați un tub temporar de colectare. În acest moment, continuați cu operațiunile de curățare a schimbătorului.
- Aspirati eventualele reziduuri de murdărie în interiorul schimbătorului, procedând cu atenție pentru a NU deteriora panoul de izolare a dispozitivului de încetinire.
- Curățați spirele schimbătorului cu o perie cu peri moi.

 **NU UTILIZAȚI PERII METALICE CARE POT DETERIORA COMPONENTELE.**

- Curățați spațiile dintre spire folosind o lamă cu o grosime de 0,4 mm, eventual disponibilă în kit.
- Aspirati eventualele reziduuri generate de curățenie.
- Clătiți cu apă, procedând cu atenție pentru a NU deteriora panoul de izolare a dispozitivului de încetinire.

 În cazul depunerilor persistente de produse de combustie pe suprafața schimbătorului de căldură, recomandăm utilizarea produselor din gama Total Defence, având grijă să NU deteriorați panoul izolant retarder.

- Lăsați să acționeze timp de câteva minute.
- Curățați spirele schimbătorului cu o perie cu peri moi.

 **NU UTILIZAȚI PERII METALICE CARE POT DETERIORA COMPONENTELE.**

- Clătiți cu apă, procedând cu atenție pentru a NU deteriora panoul de izolare a dispozitivului de încetinire.
- Verificați integritatea panoului de izolare a dispozitivului de încetinire și înlocuiți-l, urmând procedura corespunzătoare.
- După operațiunile de curățare, asamblați la loc, cu multă atenție, componentele în sens invers, conform descrierii.
- Pentru a strânge piulițele de fixare pe ansamblul transportorului aer/gaz, utilizați un cuplu de strângere de 6 Nm, urmând secvența indicată pe piesa turnată (1,2,3,4).
- Restabiliți presiunea și alimentarea cu gaz la nivelul centralei.

 Efectuați o nouă procedură "GAR", apoi scoateți alimentarea pentru cel puțin 10 secunde și, în final, efectuați o nouă procedură "GAC" (vezi par. 5.4).

 Ceea ce este indicat este valabil și în cazul înlocuirii numai a transportorului, a schimbătorului sau a ansamblului transportor și schimbător.

Curățare arzător:

- Întrerupeți alimentarea cu energie electrică, poziționând întrerupătorul general al instalației pe „oprit”.
- Închideți robinetii de interceptare a gazului.
- Scoateți carcasa conform celor indicate în paragraful "4.7 Demontarea carcasei”.
- Deconectați cablul de conexiune al electrozilor de aprindere și de detectare.
- Deconectați cablurile de alimentare ale ventilatorului.
- Desfaceți de pe mixer clema de fixare a rampei.
- Slăbiți piulița rampei de gaz.
- Desfaceți rampa de gaz de pe mixer și rotiți-o.
- Desfaceți cele 4 piulițe care fixează grupul de combustie.
- Extrageți ansamblul transportorului aer/gaz ce include ventilatorul și mixerul, procedând cu atenție pentru a nu deteriora panoul de izolare și electrozii. În acest moment, continuați cu operațiunile de curățare a arzătorului.
- Curățați arzătorul cu o perie cu peri moi, procedând cu atenție pentru a nu deteriora panoul de izolare și electrozii.

 **NU UTILIZAȚI PERII METALICE CARE POT DETERIORA COMPONENTELE.**

- Verificați integritatea panoului de izolare a arzătorului și a garniturii de etanșare și eventual înlocuiți-le, urmând procedura aferentă.
- După operațiunile de curățare, asamblați la loc, cu multă atenție, componentele în sens invers, conform descrierii.
- Pentru a strânge piulițele de fixare pe ansamblul transportorului aer/gaz, utilizați un cuplu de strângere de 6 Nm.

- Restabiliți tensiunea și alimentarea cu gaz la nivelul centralei.

⚠ Efectuați o analiză a produselor de ardere. Doar dacă returnează valori în afara toleranței, este necesar să efectuați o nouă procedură "GAR", apoi scoateți alimentarea pentru cel puțin 10 secunde și, în final, efectuați o nouă procedură "GAC" (vezi par. 5.4).

⚠ Ceea ce este indicat este valabil și în cazul înlocuirii numai a transportorului, a schimbătorului sau a ansamblului transportor și schimbător.

Înlocuire panou de izolare arzător

- Desfaceți șuruburile de fixare ale electrodului de aprindere/detectare și îndepărtați-le.
- Demontați panoul de izolare a arzătorului acționând cu o lamă sub suprafață.
- Curățați eventualele reziduuri de adeziv de fixare.
- Înlocuiți panoul de izolare pentru arzător.
- Noul panou de izolare utilizat pentru a-l înlocui pe cel demontat nu necesită fixarea cu adeziv deoarece geometria sa garantează interferența în asociere cu flanșa schimbătorului.
- Remontați electrozii de aprindere și de detectare folosind șuruburile îndepărtate anterior și înlocuind garnitura relevantă. Pentru a strânge șuruburile, aplicați un cuplu de 2,3 Nm.

⚠ Nu efectuați GAR și/sau GAC.

Verificarea și curățarea sifonului

- Deconectați micile tuburi (A - B), deșurubați șurubul (C), desfaceți clema (D) și demontați sifonul.
- Curățați din nou componentele sifonului de eventuale reziduuri solide.

⚠ Montați la loc cu atenție componentele scoase anterior.

⚠ După finalizarea secvenței de curățare, reumpleți sifonul cu apă (consultați paragraful "5.2 Prima punere în funcțiune") înainte de noua pornire a centralei.

⚠ Nu efectuați GAR și/sau GAC.

⚠ Ceea ce este indicat se aplica și în cazul înlocuirii sifonului.

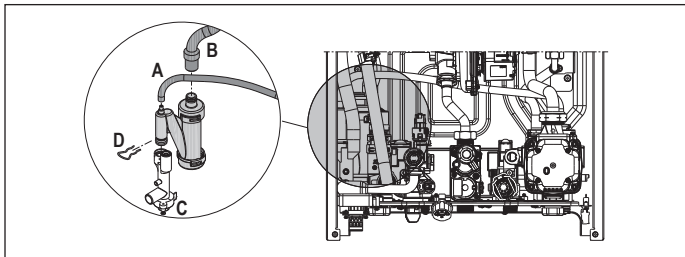

Electrozii de aprindere și detecție

Electrozii senzori de aprindere și detecție/ionizare îndeplinesc o funcție importantă în faza de aprindere a cazanului și în menținerea arderii corecte; în acest sens, în timpul întreținerii anuale, este necesar să se verifice întotdeauna dacă sunt poziționate corect și că dimensiunile de referință indicate în figură sunt respectate cu strictețe.

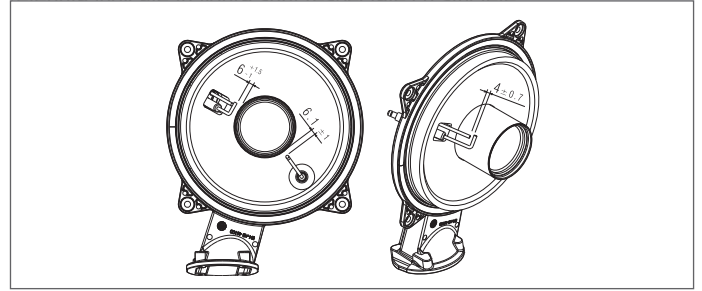

⊘ Nu șlefuiți electrozii. Dacă electrozii trebuie curățați, ștergeți-i praful folosind o perie cu peri moi.

⚠ În caz de deformare și deteriorare a electrozilor în afara toleranțelor, înlocuiți-i.

Pentru a strânge șuruburile, aplicați un cuplu de 2,3 Nm.

⚠ Pentru a preveni eventualele anomalii de funcționare, electrozii senzoriali de aprindere și de detecție/ionizare trebuie înlocuiți la fiecare 5 ani.

⚠ Efectuați o nouă procedură "GAR", apoi scoateți alimentarea pentru cel puțin 10 secunde și, în final, efectuați o nouă procedură "GAC" (vezi par. 5.4).

Înlocuire placa

- Consiliul de control și reglementare nu prevede o procedură specifică pentru verificarea deteriorării acesteia. În cazul înlocuirii, consultați paragraful "5.17 Înlocuire placă".

Înlocuire plăcii de interfață

- Placa de interfață nu oferă o procedură specifică pentru verificarea deteriorării acesteia. În cazul înlocuirii, consultați paragraful "5.16 Înlocuire interfață".

Înlocuire supapa de gaz

- Supapa de gaz nu prevede o procedură specifică pentru verificarea deteriorării sale. În cazul înlocuirii, consultați paragraful "5.15 Înlocuirea supapei de gaz (P205)".
- Supapa de gaz nu asigură o procedură specifică de curățare.

6.1 Parametri programabili

Mai jos lista de parametri programabili: UTILIZATORUL (mereu disponibil) și INSTALATORUL (acces cu parola 18): setați parola folosind procedura indicată în capitolul 10 „Setare parolă, acces și modificare parametri”.

Pentru a explica în mod detaliat parametrii, consultați cele descrise în paragraful "6.2 Descriere parametri”.

⚠ Este posibil ca unele informații să nu fie disponibile în funcție de nivelul de acces, de starea aparatului sau de configurația sistemului.

		CE PARAMETRI SUNT VIZIBILI/ACCESIBILI		
		UTILIZATOR	INSTRUCȚIUNI DE INSTALARE	SERVICE
NIVEL PAROLĂ	UTILIZATOR (mereu disponibil)	X		
	INSTRUCȚIUNI DE INSTALARE (psw 18)	X	X	
	SERVICE	X	X	X

PARAMETRI UTILIZATOR			Valoare		Nivel parolă	Valoare setată în fabrică	Valori personalizate
MENIU	PARAMETRU		Min	Max			
P1	SETARI						
	P101	LIMBA	0	10	UTILIZATOR	0	
	P102	ORA SI ZIUA			UTILIZATOR		
	P103	PROGRAM ORAR			UTILIZATOR		
	P104	UNITATE DE MASURA	0 (metric)	1 (imperial)	UTILIZATOR	0	
	P105	TEXT DERULANT	0 (dezactivat)	1 (activat)	UTILIZATOR	0	
	P106	BUZZER	0	1	UTILIZATOR	1	

PARAMETRI INSTALATOR			Valoare		Nivel parolă	Valoare setată în fabrică	Valori personalizate
MENIU	PARAMETRU		Min	Max			
P2	COMBUSTIE						
	P201	GAS - TIP GAZ	1	4	INSTALATOR	1	
	P205	d52 - P1 VANĂ GAZ	20	70	INSTALATOR dacă cazanul este oprit	45	
	P206	GAC - CALIBRARE VANĂ	0	1	INSTALATOR numai dacă există o flacără	0	
	P208	APL - PUTERE	0	1	INSTALATOR	0: 25 BIS 1: 35 BIS	

PARAMETRI INSTALATOR			Valoare		Nivel parolă	Valoare setată în fabrică	Valori personalizate
			Min	Max			
P3		CONFIGURARE					
	P301	CONFIGURATIE HIDRAULICA	0	4	INSTALATOR	2*	
	P306	VITEZA MINIMA VENTILATOR	1.000 rpm	3.600 rpm	INSTALATOR	Consultați tabelul cu parametri tehnici	
	P307	VITEZA MAXIMA VENTILATOR	3.700 rpm	10.000 rpm	INSTALATOR	Consultați tabelul cu parametri tehnici	
	P309	VITEZA MAXIMA VENTILATOR INCALZIRE	P306 (VITEZA MINIMA VENTILATOR)	P307 (VITEZA MAXIMA VENTILATOR)	INSTALATOR	Consultați tabelul cu parametri tehnici	
	P310	RANGE RATED	A NU SE MODIFICA				
	P311	IESIRE AUX	0	2	INSTALATOR	0	
	P312	RESETARE SONDA GAZE ARSE	0	1	INSTALATOR	0	
P4		INCALZIRE					
	P405	SETARI POMPA	41	100	INSTALATOR	85	
	P408	CASCADA OTBUS	NEFOLOSITĂ LA ACEST MODEL				
	P409	USCARE SAPA	0	1	INSTALATOR Dacă unitatea de încălzire este DEZACTIVATĂ și instalațiile sunt BT	0	
	P410	ANULARE TEMPORIZARE INCALZIRE	0 min	30 min	INSTALATOR	3 min	
	P411	RESETARE CRONOMETRU INCALZIRE	0	1	INSTALATOR	0	
	P415	TIP ZONA PRINCIPALA	0	1	INSTALATOR	0	
	P416	TEMP MAX ZONA P	TEMP MIN ZONA P	AT: 80°C - BT: 45°C	INSTALATOR	AT: 80°C - BT: 45°C	
	P417	TEMP MIN ZONA P	20°C	TEMP MAX ZONA P	INSTALATOR	AT: 40°C - BT: 20°C	
	P418	TERMOREGLARE ZONA P	0	1	INSTALATOR dacă sonda externă este prezentă	0	
	P419	INCLINARE CURBA ZONA P	AT: 1.0 - BT: 0.2	AT: 3.0 - BT: 0.8	INSTALATOR	AT 2.0 - BT 0.5	
	P420	COMPENSARE NOCTURNA ZONA P	0	1	doar dacă P418 = 1	0	
	P421	PROGRAMARE ORARA INCALZIRE ZONA P	0	1		0	
	P422	MAN AUTO ZONA P	0	1		0	
	P433	TIPUL CLADIRII	5	20	INSTALATOR	5	
	P434	REACTIV. SONDA EXT.	0	255	doar dacă P418 = 1	20	
		AT = TEMPERATURĂ ÎNALTĂ BT = TEMPERATURĂ JOASĂ					
P5		ACM					
	P508	TEMP MIN ACM	37°C	49°C	INSTALATOR	37°C	
	P509	TEMP MAX ACM	49°C	60°C	INSTALATOR	60°C	
	P511	FUNCTIE SPECIALA ACM	0	5	INSTALATOR	0	
	P520	ACTIVAȚI RUCSACUL	0 (dezactivat)	1 (activat)	INSTALATOR	0	
	P521	MOD STAND	0 ECO	1 COMFORT	INSTALATOR	1	

PARAMETRI SERVICE			Valoare		Nivel parolă	Valoare setată în fabrică	Valori personalizate
			Min	Max			
P3		CONFIGURARE					
	P302	TIP TRADUCTOR PRESIUNE	0	1	SERVICE	1	
	P303	ACTIVARE UMLERE INST	0	1	SERVICE	0	
	P304	PRESIUNE INITIERE UMLERE	INDISPONIBILĂ LA ACEST MODEL				
	P305	CICLU AERISIRE	0	1	SERVICE	1	
P4		INCALZIRE					
	P401	HISTEREZIS OFF TEMP INALTA	2°C	10°C	SERVICE	5°C	
	P402	HISTEREZIS ON TEMP INALTA	2°C	10°C	SERVICE	5°C	
	P403	HISTEREZIS OFF TEMP JOASA	2°C	10°C	SERVICE	3°C	
	P404	HISTEREZIS ON TEMP JOASA	2°C	10°C	SERVICE	3°C	
P5		ACM					
	P510	INTARZIERE ACM	0 sec	60 sec	SERVICE	0 sec	
	P512	INTARZ. INC POST-ACM	0	1	SERVICE	0	
	P513	TIMP INTARZ. INCALZIRE	1 sec	255 sec	SERVICE	6 sec	
P7		SERVICE					
	P701	ACTIVARE ISTORIC ALARME	0	1	SERVICE	0 (valoarea trece automat la 1 după 2 ore de funcționare)	
	P706	FUNCTIE APELARE SERVICE	0	2	SERVICE	2	
	P707	SCADENTA REVIZIE	0	255	SERVICE	52	
	P708	ACTIVARE EFICIENȚĂ RIDICATĂ	0	1	SERVICE	0	
P8		CONECTIVITATE					
	P801	CONFIG BUS 485	0	2	SERVICE	0	
	P803	CONFIG OTBUS	0	1	SERVICE	1	

*P301: 0 = DOAR ÎNCĂLZIRE - 1 = INSTANTANEE CU COMUTATOR DE DEBIT - 2 = INSTANTANEE CU DEBITMETRU - 3 = BOILER CU SONDĂ - 4 = BOILER CU TERMOSTAT



Cazanul cu DOSSERET nu permite utilizarea dispozitivului T300; parametrul 801 trebuie setat la 0.

Dacă centrala este combinată cu un set DOSSERET (accesoriu disponibil la cerere), parametrii pentru utilizarea acestuia din urmă trebuie programați înainte de utilizarea centralei.

6.2 Descriere parametri

Unele dintre următoarele funcții ar putea să nu fie disponibile în funcție de tipul de aparat și de nivelul de acces.

PARAMETRU	DESCRIERE
P1 - SETARI	P101 Pentru a seta limba dorită: 0: IT ● 1: RO ● 2: FR ● 3: EN ● 4: SR ● 5: HR ● 6: ES ● 7: GR ● 8: BG ● 9: PL ● 10: SL
	P102 Pentru a seta ORA și ZIUA
	P103 Pentru a seta PROGRAMAREA ORARĂ
	P104 Pentru a schimba unitatea de măsură: 0 = unități de măsură METRICE / 1 = unități de măsură IMPERIALE. Cifrele sunt exprimate în format zecimal (o cifră) pentru valori cuprinse între -9°C și +99°C, sunt exprimate în format întreg pentru valori ≤ -10°C și ≥ 100°C, vizualizarea în °F (Fahrenheit) va fi exprimată mereu în format întreg.
	P105 Pentru a seta textul derulant: 0 = DEZACTIVAT / 1 = ACTIVAT
	P106 Pentru a activa/dezactiva semnalizarea sonoră: 0 = buzzer DEZACTIVAT / 1 = buzzer ACTIVAT
P2 - COMBUSTIE	P201 Acest parametru identifică tipul de gaz: 1=METAN ● 2=GPL ● 3=PL-NG ● 4=PROPAN (G230).
	P208 Acest parametru este folosit pentru a seta puterea unității de încălzire: 0 - 1. Pentru detalii, consultați „Parametri programabili”
	P205 Acest parametru este folosit pentru a reseta valoarea P1 a supapei de gaz
	P206 Acest parametru este folosit pentru a calibra supapa de gaz și sistemul de comandă al arderii
P3 - CONFIGURARE	P301 Pentru a seta tipul de configurație hidrolică a unității de încălzire: 0 = DOAR ÎNCĂLZIRE - 1 = INSTANTANEE CU COMUTATOR DE DEBIT - 2 = INSTANTANEE CU DEBITMETRU - 3 = BOILER CU SONDĂ - 4 = BOILER CU TERMOSTAT Valoarea din fabrică = 2, nu o modificați. În cazul înlocuirii plăcii electronice, asigurați-vă că acest parametru este setat la 2.
	P302 Pentru a seta tipul de traductor presiune apă: 0 = presostat apă - 1 = traductor de presiune Valoarea din fabrică = 1, nu o modificați. În cazul înlocuirii plăcii electronice, asigurați-vă că acest parametru este setat la 1.
	P303 Pentru a activa funcția de „reumplere semiautomată” când în unitatea de încălzire sunt instalate un traductor de presiune și o electrovalvă de umplere. Valoarea din fabrică = 0, nu o modificați. În cazul înlocuirii plăcii electronice, asigurați-vă că acest parametru este setat la 0.
	P304 Apare doar dacă P303 = 1. INDISPONIBIL LA ACEST MODEL.
	P305 Pentru a dezactiva funcția ciclului de purjare. Valoarea din fabrică = 1, setați parametrul la 0 pentru a dezactiva funcția.
	P306 Pentru a modifica numărul minim de rotații ale ventilatorului.
	P307 Pentru a modifica numărul maxim de rotații ale ventilatorului.
	P309 Pentru a modifica numărul maxim de rotații de încălzire ale ventilatorului (poate fi programat în interiorul domeniului P306 - P307).
	P310 Reglare GAMA NOMINALĂ. A NU SE MODIFICA.
	P311 Pentru a configura funcționarea unui releu suplimentar (doar dacă placa BE09 este instalată (kit accesorii) pentru a aduce o fază (230 V c.a.) la o a doua pompă de încălzire (pompă suplimentară) sau la o supapă de zonă. Valoarea din fabrică = 0 și poate fi programată în interiorul domeniului 0 - 2 cu următoarea explicație: P311= 0 - gestionarea depinde de configurația cablajului plăcii BE09: jumper tăiat: pompă suplimentară - jumper prezent: supapă de zonă. P311= 1 - gestionare supapă de zonă P311= 2 - gestionare pompă suplimentară
	P312 Permite resetarea contorului orelor de funcționare în anumite condiții (consultați „Semnalizări și anomalii” pentru mai multe detalii, anomalia E091). Valoarea din fabrică = 0, aduceți la 1 pentru a reseta contorul orelor de gaze arse după o intervenție de curățare a schimbătorului de căldură primar. După finalizarea procedurii de resetare, parametrul revine automat la valoarea 0.
P4 - ÎNCĂLZIRE	P401 Pentru instalațiile la temperatură înaltă, acest parametru permite setarea valorii de histerezis folosit de placa de reglare pentru calcularea temperaturii de tur pentru oprirea arzătorului: TEMPERATURA DE OPRIRE = VALOARE DE REFERINȚĂ ÎNCĂLZIRE + P401. Valoarea din fabrică = 5°C, poate fi modificată în domeniul 2 - 10°C.
	P402 Pentru instalațiile la temperatură înaltă, acest parametru permite setarea valorii de histerezis folosit de placa de reglare pentru calcularea temperaturii de tur pentru pomirea arzătorului: TEMPERATURA DE PORNIRE = VALOARE DE REFERINȚĂ ÎNCĂLZIRE - P402. Valoarea din fabrică = 5°C, poate fi modificată în domeniul 2 - 10°C.
	P403 Pentru instalațiile la temperatură joasă, acest parametru permite setarea valorii de histerezis folosit de placa de reglare pentru calcularea temperaturii de tur pentru oprirea arzătorului: TEMPERATURA DE OPRIRE = VALOARE DE REFERINȚĂ ÎNCĂLZIRE + P403. Valoarea din fabrică = 3°C, poate fi modificată în domeniul 2 °C - 10°C.
	P404 Pentru instalațiile la temperatură joasă, acest parametru permite setarea valorii de histerezis folosit de placa de reglare pentru calcularea temperaturii de tur pentru pomirea arzătorului: TEMPERATURA DE PORNIRE = VALOARE DE REFERINȚĂ ÎNCĂLZIRE - P404. Valoarea din fabrică = 3°C, poate fi modificată în domeniul 2 °C - 10°C.
	P405 Pompă cu viteză variabilă proporțională.
	P408 Permite setarea unității de încălzire pentru utilizări în cascadă prin semnalul OT+. Inaplicabil pentru acest model de unitate de încălzire.
	P409 Permite activarea funcției de încălzire șapă (consultați paragraful „Funcție de încălzire a zonei inițiale” pentru mai multe detalii). Valoarea din fabrică = 0, cu unitatea de încălzire în modul DEZACTIVAT. Setati la 1 pentru a activa funcția de încălzire șapă pe zonele de încălzire la temperatură joasă. Parametrul revine automat la valoarea 0 după ce s-a finalizat funcția de încălzire șapă; este posibilă întreruperea acesteia în avans setând valoarea la 0.
	P410 Permite să modificați valoarea pentru temporizare oprită forțat încălzire, referitoare la timpul de întârziere introdus pentru reaprinderea arzătorului față de cel oprit pentru a atinge temperatura pentru încălzire. Valoarea din fabrică = 3 minute și poate fi setată la o valoare cuprinsă între 0 min și 20 min.
	P411 Permite anularea funcției de RESETARE TIMPI ÎNCĂLZIRE și a TEMPORIZĂRII PUTERII MAXIME DE ÎNCĂLZIRE REDUSA, în timpul căreia viteza ventilatorului este limitată între valoarea minimă și 60% din puterea maximă de încălzire setată, cu o creștere de 10% la fiecare 15 minute. Valoarea din fabrică = 0, setați 1 pentru resetarea temporizării.
	P415 Permite să indicați tipul zonei care trebuie încălzită, fiind posibil să alegeți dintre următoarele opțiuni: 0 = TEMPERATURĂ RIDICATĂ (valoare setată din fabrică) ● 1 = TEMPERATURĂ JOASĂ
	P416 Permite specificarea valorii maxime de referință de încălzire, ce poate fi setată: domeniu 20°C - 80°C, implicit 80°C pentru instalații de înaltă temperatură ● domeniu 20°C - 45°C, implicit 45°C pentru instalații de joasă temperatură. Observație: valoarea P416 nu poate fi mai mică de P417.
	P417 Cu acest parametru se poate specifica valoarea minimă de referință pentru încălzire, ce poate fi setată: domeniu 20°C - 80.5°C, implicit 40°C pentru instalații de înaltă temperatură ● domeniu 20°C - 45°C, implicit 20°C pentru instalații de joasă temperatură Observație: valoarea P417 nu poate fi mai mare de P416.
	P418 Permite activarea termoreglării când la sistem este conectată o sondă externă. Valoarea din fabrică = 0, unitatea de încălzire funcționează mereu într-un punct fix. Cu parametrul 1 și sonda externă conectată, unitatea de încălzire funcționează în modul de termoreglare. Cu sondă externă deconectată, unitatea de încălzire funcționează mereu într-un punct fix. Consultați paragraful „Setarea termoreglării” pentru mai multe detalii despre această funcție.
	P419 Permite setarea numărului curbei de compensare utilizată de unitatea de încălzire când se află în modul de termoreglare. Valoarea din fabrică = 2.0 pentru instalațiile la temperatură înaltă și 0,5 pentru cele la temperatură joasă. Parametrul poate fi programat în domeniul 1.0-3.0 pentru sistemele la temperatură înaltă, 0.2-0.8 pentru cele la temperatură joasă. Consultați paragraful „Setarea termoreglării” pentru mai multe detalii despre această funcție.
	P420 Activează funcția „compensare nocturnă”. Valoarea implicită = 0, setați parametrul la 1 pentru a activa funcția. Consultați paragraful „Setarea termoreglării” pentru mai multe informații despre această funcție.
P421 Acest parametru permite activarea programării orare pentru încălzire. Programare orară care nu este activată = 0 → La închiderea contactului termostatului de ambient, cererea de căldură este mereu îndeplinită fără limitarea timpului. Programare orară care nu este activată = 1 → Atunci când este închis contactul termostatului de ambient, cererea de căldură este activată în funcție de programarea orară setată.	
P422 Acest parametru permite setarea modului de trecere din modul de funcționare pentru încălzire manuală în modul de încălzire automată. Valoarea implicită = 0: trecerea de la programarea orară manuală la cea automată trebuie efectuată de către utilizator acționând tastele C+D. Setați la 1 pentru activarea funcției: trecerea de la programarea orară manuală la cea automată se produce automat la primul schimb al intervalului de timp.	
P433 Frecvența cu care este actualizată valoarea temperaturii externe calculate pentru reglare termică; pentru clădirile insuficient izolate se va utiliza o valoare scăzută	
P434 Intervalul de citire a valorii temperaturii externe citite de sondă.	
P5 - ACM	P501-P507 Funcții referitoare la disponibilitatea unui boiler. INDISPONIBILE LA ACEST MODEL.
	P508 Pentru setarea valorii de referință minime pentru apa caldă menajeră.
	P509 Pentru setarea valorii de referință maxime pentru apa caldă menajeră.
	P510 Vizibil doar când parametrul P511= 2 sau 5. Este introdusă o întârziere în secunde pentru activarea pompei și ventilatorului ca răspuns la o solicitare de încălzire pentru apă menajeră.
	P511 Activează funcții speciale pentru apa menajeră: 0 = nicio funcție - 1 = introducere întârziere activare fluxostat/debitmetru - 2 = în caz de DEZACTIVARE pentru supratemperatura apei menajere (cu preluare în curs) ventilatorul este menținut la viteza minimă pentru a reduce intervalele de timp de așteptare - 3 = termostate sanitare absolute - 4 = funcție apă menajeră smart antioscilații - 5 = toate funcțiile precedente active.
	P512 Prin intermediul acestei valori este posibilă activarea/dezactivarea funcției de postcirculare a apei menajere cu inhibarea activării încălzirii.
	P513 Prin intermediul acestei valori este posibilă setarea duratei postcirculării apei menajere când funcția de postcirculare a apei menajere cu inhibarea activării încălzirii este activată.
	P520 Pentru a permite funcționarea centralei în combinație cu dossierer
P521 Alegerea COMFORT face ca centrala să aibă cicluri de resetare a centralei mai multe și mai frecvente (TANK). Este recomandată în aplicații casnice în care ciclurile de preluare sunt frecvente sau unde cererea de volum de apă este mai mare. Opțiunea ECO face ca centrala să aibă un număr redus de cicluri de recuperare a dispozitivelor de încălzire (TANK). Alegerea trebuie făcută acolo unde se acordă o mai mare importanță economisirii energiei	

P7 - SERVICE	P701	Pentru activarea memorării unui istoric de alarme. Valoare implicită 0; valoarea trece automat la 1 după 2 ore de funcționare. Setarea parametrului la valoarea 0 resetează istoricul alarmelor I039...I043.
	P706	Acest parametru permite controlul periodic al unității de încălzire după o perioadă de funcționare prestabilă în parametrul P707. Sunt disponibile trei valori ale setărilor: 0 = funcție dezactivată 1 = funcție activată după următoarea regulă: Dacă P707 < 4, afișajul prezintă semnalul CFS Dacă P707 = 0, afișajul prezintă semnalul SFS (STOP FOR SERVICE) care indică inhibarea permanentă a tuturor solicitărilor de căldură pentru încălzire și apa menajeră. Neresetabilă 2 = funcție activată: Când P707 = 0, afișajul prezintă semnalul CFS fără nicio oprire a funcționării În această stare, în meniul INFO (rândul I044), este afișat numărul de zile trecute de la momentul în care semnalul CFS a apărut (P707 = 0)  Semnalul CFS apare la intervale de 10 minute pe o durată de 1 min, cu 1 lună înainte de finalizarea perioadei setate în parametrul P707.
	P707	Perioada de funcționare prestabilă pentru solicitarea de service (parametrul P706)
	P708	Funcție automată care se activează la prima alimentare sau după 60 zile de neutilizare (unitate de încălzire alimentată cu energie electrică). În acest mod, unitatea de încălzire, timp de 60 minute, limitează la minim puterea de încălzire și temperatura maximă pentru apa menajeră la 55°C. Activarea funcției coșar dezactivează temporar această funcție. 0 = VALOARE DIN FABRICĂ, dezactivează modul de înaltă eficiență • 1 = activează modul de înaltă eficiență
P8 - CONECTIVITATE	P801	Acest parametru este utilizat pentru a activa gestionarea de la distanță a unității de încălzire. Sunt disponibile trei valori: 0 = VALOAREA DIN FABRICĂ. 1 = Gestionare DOAR de pe interfața unității de încălzire. 2 = Gestionare de pe interfața unității de încălzire și managerul de sistem (T300).
	P803	Acest parametru este utilizat pentru a activa gestionarea de la distanță a unității de încălzire printr-un dispozitiv OpenTherm: 0 = Funcționalitatea OT+ dezactivată, nu este posibilă controlarea de la distanță a unității de încălzire utilizând un dispozitiv OTBus. Setând acest parametru la 0, o eventuală conexiune OTBus este întreruptă imediat. Pictograma  și textul OTB de pe afișaj sunt dezactivate 1 = VALOAREA DIN FABRICĂ. Funcționalitatea OT+ activată, este posibilă conectarea unui dispozitiv OTBus pentru controlul de la distanță al unității de încălzire. Conectând un dispozitiv OTBus la unitatea de încălzire, pe afișaj apare mesajul "OTB" și se aprinde pictograma  .

Notă: Compatibilitatea totală cu dispozitive OpenTherm ale terților nu este garantată.

Cazanul cu DOSSERET nu permite utilizarea dispozitivului T300; parametrul 801 trebuie setat la 0.

6.3 Meniu INFO

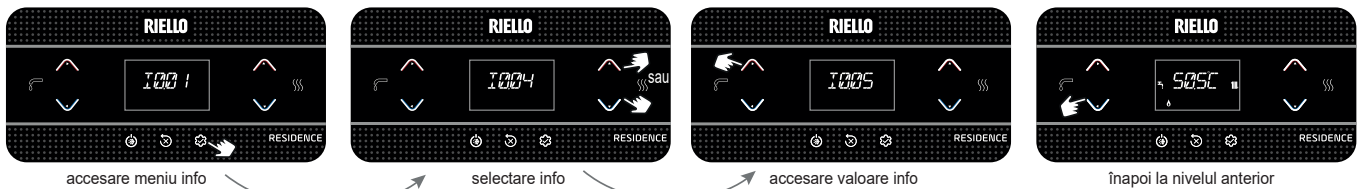







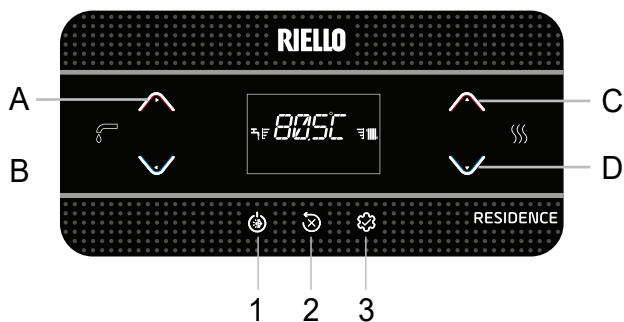















 Dacă nu sunt acționate tastele, după 60 secunde, interfața părăsește automat meniul INFO.

SETARE TUR ZONA P OT	DESCRIERE	
I001	ORE USCARE SAPA	Număr de ore petrecute pentru funcția de încălzire șapă (când este în curs de funcționare)
I002	SONDA TUR	Valoare sondă de tur unitate de încălzire
I003	SONDA RETUR	Valoare sondă de retur unitate de încălzire
I004	SONDA ACM	Valoare sondă pentru apă menajeră când unitatea de încălzire este instantanee
I005	SETARI ACM	Valoare de referință pentru apa menajeră unitatea de încălzire sau de la OT+ când cronotermostatul este conectat
I008	SONDA GAZE ARSE	Valoare sondă gaze arse
I009	SONDA EXTERNA	Valoare instantanee sondă externă
I010	TEMP EXTERNA PENTRU TERMOREGLARE	Valoare filtrată sondă externă utilizată în algoritmul de termoreglare pentru calculul valorii de referință de încălzire
I011	DEBIT ACM	Debit ACM
I012	TURATIE VENTILATOR	Număr de rotații ventilator (rpm)
I015	CONTOR SONDA GAZE ARSE	Număr ore de funcționare al schimbătorului în „regim de condensare” (valorile sunt exprimate în sute de ore, exemplu: 01 = 100h)
I016	SETARE TUR ZONA P	Valoare de referință de tur zona principală
I017	SETARE TUR ZONA P OT	Valoare de referință de tur zona principală de la OT+
I018	PRESIUNE INSTALATIE	Presiune instalație
I019	ORE FUNCTIONARE ACM	Ore arzător acces la apă caldă menajeră
I020	ORE FUNCTIONARE ÎNCALZIRE	Ore arzător acces la încălzire
I021	MODULARE ACM	Media valorii procentuale de modulare cu arzător pomit pentru apa caldă menajeră
I022	MODULARE ÎNCALZIRE	Media valorii procentuale de modulare cu arzător pomit pentru încălzire
I023	MEDIA SENZOR TUR ÎNCALZIRE	Media valorii sondă tur cu arzător pomit pentru încălzire
I024	MEDIA SENZOR TUR ACM	Media valorii sondă tur cu arzător pomit pentru apă caldă menajeră
I025	MEDIA RETUR ÎNCALZIRE	Media valorii sondă retur cu arzător pomit pentru încălzire
I026	MEDIA RETUR ACM	Media valorii sondă retur cu arzător pomit pentru apă caldă menajeră
I027	NUMĂR DESCHIDERI VANĂ GAZ	Număr de cicluri ACTIVARE supapă de gaz
I029	EFICIENTĂ RIDICATĂ	Dacă este la 1, este indicată necesitatea de a verifica sifonul pentru reumplere
I030	CONFORT ACM	Confort apă menajeră
I031	FUNCTIE SPECIALA ACM	Funcții speciale active pentru temperatura apei menajere la intrare înaltă
I033	INFO PLACA ELECTRONICA	Tip de placă conectată
I034	SW PLACA ELECTRONICA	Revizie firmware a schemei electronice
I035	SW INTERFATA	Revizie firmware interfață
I036	SEMNAL RADIO	Arată calitatea conexiunii wi-fi
I039	ISTORIC ALARMĂ 1 (cele mai vechi)	
I040	ISTORIC ALARMĂ 2	
I041	ISTORIC ALARMĂ 3	Lista ultimelor cinci alarme înregistrate
I042	ISTORIC ALARMĂ 4	
I043	ISTORIC ALARMĂ 5 (cele mai recente)	
I044	ÎNTRETINERE SCHIMBĂTOR	Număr de zile trecute de la momentul în care s-a activat semnalizarea CFS (P707 = 0)
I046	RSC	Fw revizuirea dezvoltării confortului
I047	RS	Fw revizuirea de siguranță
I048	RSS	Fw revizuirea dezvoltării siguranței
I049	RF	Recenzie fan FW

7 PANOU DE COMANDĂ



A	Este utilizat de obicei pentru a mări valoarea temperaturii apei calde menajere, când este evidențiată săgeata  , se derulează în schimb funcția de confirmare
B	Este utilizat de obicei pentru a reduce valoarea temperaturii apei calde menajere, când este evidențiată săgeata  , se derulează funcția de backlanulare
A+B	Acces la funcțiile de confort apă caldă menajeră (consultați paragraful "5.6 Funcția „Confort apă menajeră”")
C+D	Programare manuală a timpului de încălzire, schimbarea statutului
C	ESTE utilizat de obicei pentru a mări valoarea temperaturii apei pentru încălzire, când este evidențiată săgeata  , este posibilă derularea în interiorul meniului P1
D	ESTE utilizat de obicei pentru a reduce valoarea temperaturii apei pentru încălzire, când este evidențiată săgeata  , este posibilă derularea în interiorul meniului P1
A+C	Acces la meniul de setare a ceasului (consultați paragraful "8 INSTRUCȚIUNI DE UTILIZARE")
B+D	Programare orară
1	Utilizat pentru a modifica starea de funcționare a centralei (DEZACTIVARE, VARĂ ȘI IARNĂ)
2	Utilizat pentru a reseta starea de alarmă sau pentru a întrerupe ciclul de purjare
3	Utilizat pentru a accesa la meniurile INFO (apăsare ușoară) și P1 (apăsare > 2 sec). Când pe ecran apare pictograma  , tasta are funcția de ENTER și este utilizată pentru a confirma valoarea setată în timpul programării unui parametru tehnic
1+3	Blocare și deblocare taste
2+3	Când centrala se află în starea de DEZACTIVARE, servește pentru activarea funcției de ardere (CO)

	Indică conexiunea la un dispozitiv la distanță (OTBus sau RS485)
	Indică conexiunea la un dispozitiv WIFI
	Indică prezența unei sonde externe
	Indică activarea unor funcții speciale pentru apa caldă menajeră sau prezența instalației pentru gestionarea panoului solar termic
	Pictogramă care se aprinde ca răspuns la o alarmă
	Se aprinde în caz de eroare împreună cu pictograma  , excluzând alarmele de flacără și apă
	Indică prezența unei flăcări, în caz de blocare flacără, pictograma apare ca 
	Se aprinde intermitent cu alarme temporare privind apa; se aprinde continuu cu alarmă definitivă
Reset	Se aprinde în prezența alarmelor care solicită o intervenție de deblocare manuală din partea operatorului
Enter	Se aprinde când este solicitată o operațiune de confirmare
	Când pictograma este activă, indică faptul că este activă funcția de „confirmare” a tastei A
	Când pictograma este activă, indică faptul că este activă funcția de „backlanulare” a tastei B
	Când pictograma este activă, este posibilă navigarea în meniu sau creșterea valorii parametrului selectat
	Când pictograma este activă, este posibilă navigarea în meniu sau scăderea valorii parametrului selectat
	Pictograma se aprinde când încălzirea este activă, se aprinde intermitent dacă solicitarea de încălzire este în curs
	Pictograma se aprinde când apa caldă menajeră este activă, se aprinde intermitent dacă solicitarea de apă caldă menajeră este în curs
	Indică nivelul valorii de referință setate (1 marcaj - valoare minimă, 4 marcaje - valoare maximă)
1 2 3 4 5 6 7	Indică zilele săptămânii
AUTO ON 	Programare orară
MAN ON	Programare orară manuală ACTIVATĂ
MAN OFF	Programare orară manuală DEZACTIVATĂ

8 INSTRUCȚIUNI DE UTILIZARE

- Aduceți întrerupătorul general al instalației pe poziția „pornit”.
- Deschideți robinetul de gaz pentru a permite fluxul carburantului.
- Cu activarea alimentării electrice, se aprinde retroiluminatul, se aprind toate pictogramele și segmentele timp de 1 sec și în succesiune rezvizia firmware-ului al plăcii de comandă este afișată timp de 3 sec:

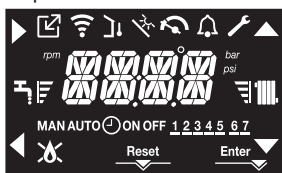

Dacă nu este setată, programarea orei și zilei din săptămână este solicitată în mod automat la pornirea dispozitivului. Pe ecranul principal se aprind pictogramele ▲, ▼, ► și ◀ și ENTER în timp ce textul 00:00 este afișat cu primele două cifre ce se aprind intermitent cu o frecvență de 0,5 sec ACTIVATE, 0,5 sec DEZACTIVATE.



Pentru a seta ora și ziua, urmați aceste instrucțiuni:

- setați ora cu săgețile ▲ și ▼, apoi confirmați cu tasta A
- setați minutele cu săgețile ▲ și ▼, apoi confirmați cu tasta A
- setați ziua din săptămână cu săgețile ▲ și ▼. Segmentul ce corespunde zilei selectate se aprinde intermitent, apăsați pe tasta MENU ce corespunde pictogramei Enter pentru a confirma setarea orei și zilei. Ceasul se aprinde intermitent timp de 4 sec și ulterior se revine la ecranul principal
- Pentru a părăsi programarea orei fără a salva valorile modificate, este suficient să apăsați pe tasta ◀.

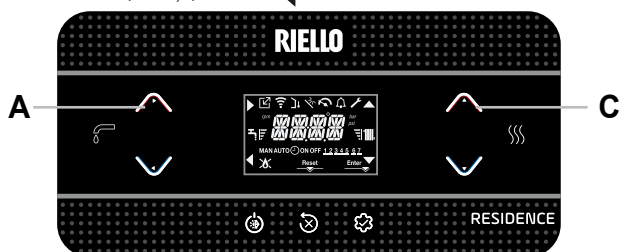

OBSERVAȚIE: Este posibilă modificarea setărilor de ORĂ și ZI chiar și ulterior, accesând meniul SETĂRI, parametrul P1 → P102, sau apăsați pe tastele A+C timp de minim 2 sec.

- Pornește apoi ciclul de purjare automat, dacă este activat, cu durata de 4 minute (pentru detalii, consultați paragraful "5.3 Ciclul de purjare").
- Ulterior, interfața va trece la modul de vizualizare asociată stării active la momentul respectiv.

 Reglați termostatul de ambient la temperatura dorită sau, dacă instalația este dotată cu un cronotermistat sau programator orar, verificați să fie „activ” și reglat.

- Treceți centrala în starea de IARNĂ sau VARĂ.

8.1 Funcția program orar (termostat de ambient)

Dacă instalația de încălzire este gestionată de un termostat de ambient, fără o programare orară, poate fi activată programarea orară prezentă pe interfața centralei setând parametrul P4 → P421 = 1. Pentru a activa meniul programării orare pentru încălzire automată, apăsați pe tastele B+D timp de cel puțin 2 sec pe ecranul principal.

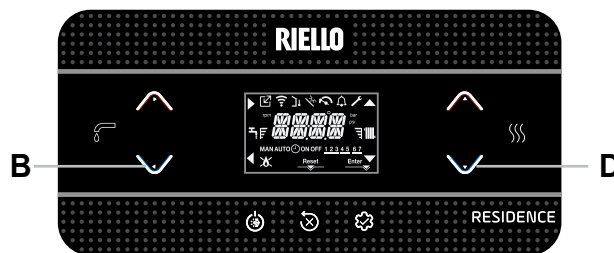

Ecranul arată ca în figura următoare:

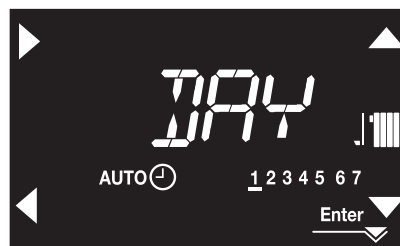

Prin săgețile ▲, ▼ se selectează ziua sau grupul de zile preselectat:
 1-2-3-4-5-6-7 programarea zilelor individuale
 1-5 programare de luni până vineri
 6-7 programare de sâmbătă până duminică
 1-7 programare pentru întreaga săptămână

Cu tasta ► se confirmă selecția realizată și se trece la programarea intervalelor orare, cu tasta Enter se părăsește meniul de programare orară, confirmând modificările efectuate.

Cu tasta ◀ se părăsește programarea anulând selecțiile.

Setarea intervalelor orare

- Pe ecran apare ORA ACTIVATĂ 1, apăsați pe ► pentru a seta orarul de aprindere, cu ▲, ▼ modificați orarul, confirmați cu ►.
- Pe ecran apare ORA DEZACTIVATĂ 1, apăsați pe ► pentru a seta orarul de stingere, cu ▲, ▼ modificați orarul, confirmați cu ►.
- Apare ORA ACTIVATĂ 2, prin urmare, se reia programarea intervalelor orare până când se atinge numărul maxim de intervale programabile (patru), sau se acționează Enter pentru a confirma intervalele setate și pentru a trece la programarea zilei următoare.

În afara acestor intervale orare, solicitările de căldură de la termostatul de ambient nu sunt luate în considerare.

Intervalele orare de încălzire autorizate în mod implicit sunt:

- de LUNI până VINERI: 07:30 ÷ 08:30 / 12:00 ÷ 13:30 / 18:00 ÷ 22:30
- de SÂMBĂTĂ până DUMINICĂ: 08:00 ÷ 22:30.

Când este autorizată programarea orară pentru încălzire, acționarea tastelor C+D permite trecerea de la programarea orară AUTO la cea MANUALĂ ACTIVATĂ sau MANUALĂ DEZACTIVATĂ.

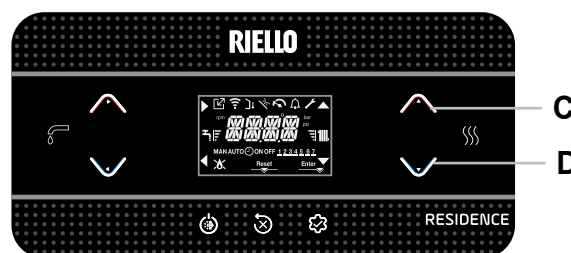

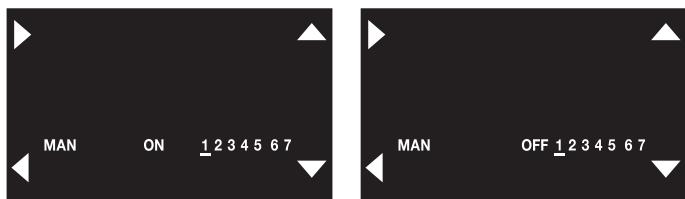
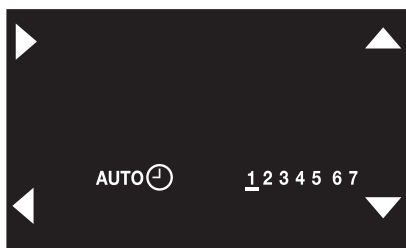

8.2 Starea de funcționare

- Acționând tasta 1, tipul de funcționare variază în mod ciclic de la DEZACTIVARE - VARĂ - IARNĂ și, la final, din nou la DEZACTIVARE.

În starea OPRIT, valoarea presiunii apei apare pe afișaj la fiecare 2 secunde.

- În cazul în care nicio tastă nu este acționată timp de 60 secunde, interfața trece în modul de așteptare. În mod normal, este afișată valoarea de presiune, cu excepția cazului în care nu a existat o solicitare de căldură (în acest caz, pe ecran este afișată temperatura). În cazul în care ora este setată, valoarea presiunii este înlocuită de ora actuală.

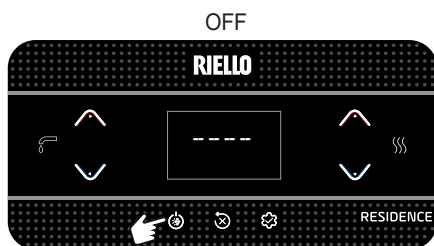

așteptare



temperatura de livrare a încălzirii



temperatura ACM



STAREA IARNĂ

Centrala activează funcția de încălzire și apa caldă menajeră, prezenta pictogramei indică o solicitare de căldură și aprinderea arzătorului.

STARE DE IARNA

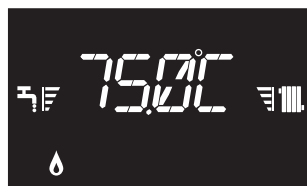

STAREA VARĂ

Centrala activează funcția tradițională de apă caldă menajeră exclusivă.

STARE DE VARĂ

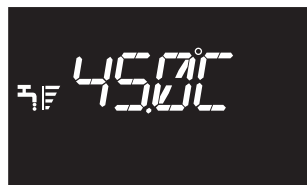

8.3 Setare valoare de referință de încălzire

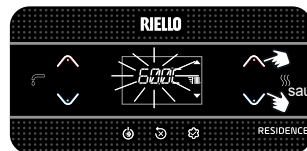

prima apăsare

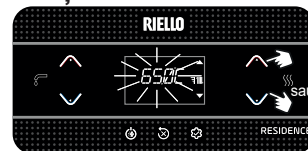

a doua apăsare setați valoarea de referință a ÎNC în trepte de 0.5 °C

Dacă nu este acționată nicio tastă timp de 5 sec., valoarea setată este preluată ca valoare nouă de referință pentru încălzire.

8.4 Setare valoare de referință de încălzire cu sondă externă

Cu sonda externă conectată (opțional) și termostatarea activată (parametrul P4 → P418=1), valoarea temperaturii de tur este selectată automat de sistemul ce asigură adaptarea rapidă a temperaturii ambiante în funcție de variațiile temperaturii externe.

Modificarea valorii de referință pentru încălzire



Corecția valorii de referință se încadrează în domeniul de valori (-5 +5 °C).

Cu parametrul P4 → P418=0 centrala funcționează într-un punct fix.

8.5 Reglare valoare de referință pentru apa menajeră



prima apăsare

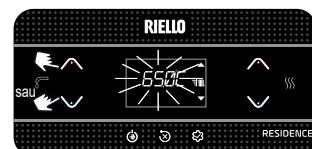

a doua apăsare setați valoarea de referință a ACM în trepte de 0.5 °C

Dacă nu este acționată nicio tastă timp de 5 sec., valoarea setată este preluată ca valoare nouă de referință pentru apa caldă menajeră.

8.6 Oprire de siguranță

În cazul în care apar anomalii la pornire sau la funcționare, centrala va efectua o „OPRIRE DE SIGURANȚĂ”. Pe ecran este prezentat codul de eroare observat. Pentru detalii, consultați "5.14 Semnalizări și anomalii".

Funcție de deblocare

Contactați echipa de Asistență Tehnică locală dacă încercările de deblocare nu reactivează funcționarea normală.



8.7 Oprire temporară

În cazul unor absențe temporare (la sfârșit de săptămână, scurte călătorii etc.) setați starea centralei pe OFF (DEZACTIVARE).

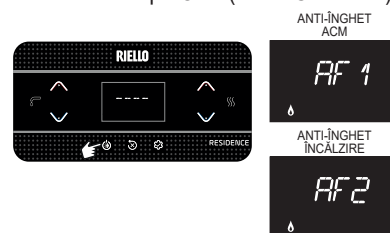

Rămânând active alimentarea electrică și alimentarea pe bază de combustibil, centrala este protejată de sistemele:

- anti-îngheț încălzire:** funcția se activează dacă temperatura detectată de sonda de tur scade sub 5°C. În această fază este generată o cerere de căldură cu pornirea arzătorului la puterea minimă, care

este menținută până când temperatura apei de tur va ajunge la 35°C; Pe afișaj este prezentat mesajul „AF2” (cu P105 = 1 text derulant --> FUNCTIE ANTIINGHET INCALZIRE IN CURS).

- **anti-îngheț apă caldă menajeră:** funcția se activează dacă temperatura detectată de sonda de apă menajeră scade sub 5°C. În această fază este generată o cerere de căldură cu pornirea arzătorului la puterea minimă, care este menținută până când temperatura apei de tur va ajunge la 55°C; Pe afișaj este prezentat mesajul „AF1” (cu P105 = 1 text derulant --> FUNCTIE ANTIINGHET ACM IN CURS).
- **antiblocare circulator:** pompa de circulație se activează la fiecare 24 de ore, timp de 30 de secunde.

8.8 Oprirea pentru perioade lungi de timp

Neutilizarea centralei pentru o perioadă îndelungată de timp presupune executarea următoarelor operațiuni:

- Setează starea de DEZACTIVARE
- poziționați întrerupătorul general al instalației pe „oprit”
- Închideți robinetele de carburant și de apă ale instalației de încălzire și de apă menajeră.

În acest caz, sistemele anti-îngheț și antiblocare sunt dezactivate. Goliți instalația termică și sanitară, dacă există riscul de îngheț.

8.9 Funcție de blocare tastatură

Pentru a bloca tastele

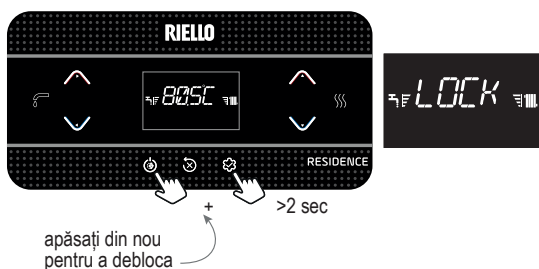

În cazul unei erori, tasta 2 rămâne activă pentru resetarea alarmei.

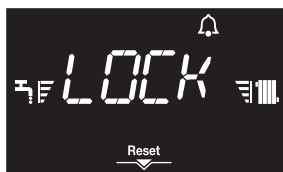

8.10 Istoric alarme

Istoricul de alarme este activ cu parametrul P7 → P701=1 (SERVICE). Alarmerile pot fi vizualizate după cum urmează:

- în meniul INFO (de la I039 la I043), în ordine cronologică, de la cea mai recentă la cea mai veche, până la maximum 5 alarme.

Dacă o alarmă apare de mai multe ori la rând, este memorată doar o singură dată.

Pentru resetarea alarmei, urmați indicațiile furnizate în paragraful "8.6 Oprire de siguranță".

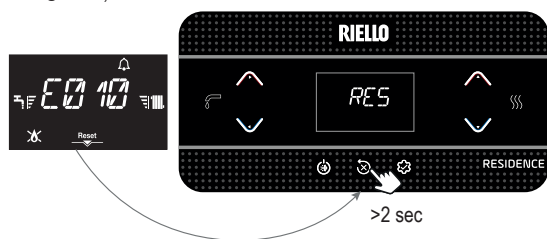

8.11 Meniul de conectivitate

Gestionarea de la distanță a cazanului se poate face prin:

- **Wi-Fi key (Nu este disponibil)**

Este, de asemenea, posibilă activarea managementului de la distanță prin intermediul unui cronotermostat OpenTherm.

Notă: Compatibilitatea totală cu dispozitive OpenTherm ale terților nu este garantată.

Notă: telecomanda T100 nu poate fi conectată la centrală dacă sistemul este hibrid (prezența unei pompe de căldură).



8.12 Funcție BIBERON





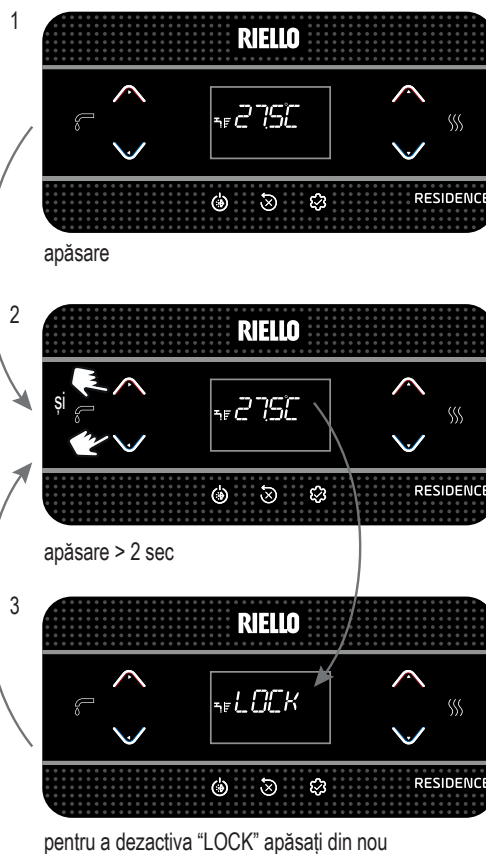









Funcția biberon permite blocarea valorii setate în valoarea de referință pentru apa menajeră, prevenind modificarea accidentală a acesteia.

Pentru a activa funcție Biberon, de pe ecranul cu valoarea de referință pentru apa menajeră:



Σε περίπτωση συνδυασμού του λέβητα με το kit DOSSERET, είναι απαραίτητο να προγραμματιστεί κατάλληλα η παράμετρος P520 (βλ. παράγραφο «6.1 Προγραμματιζόμενες παράμετροι»)

1 ΟΔΗΓΙΕΣ ΠΡΟΦΥΛΑΞΗΣ ΚΑΙ ΑΣΦΑΛΕΙΑΣ

-  Οι λέβητες που παράγονται στις εγκαταστάσεις μας κατασκευάζονται με προσοχή σε κάθε μεμονωμένο εξάρτημα, ώστε να προστατεύεται τόσο ο χρήστης όσο και ο υπεύθυνος εγκατάστασης από τυχόν ατυχήματα. Θα πρέπει λοιπόν το καταρτισμένο προσωπικό, κατόπιν οποιασδήποτε παρέμβασης στο προϊόν, να δίνει ιδιαίτερη προσοχή στις ηλεκτρικές συνδέσεις, κυρίως όσον αφορά το γυμνό μέρος των αγωγών, που δεν πρέπει σε καμία περίπτωση να εξέλθει από την πλακέτα ακροδεκτών, αποφεύγοντας έτσι την ενδεχόμενη επαφή με τα ενεργά μέρη του ιδίου.
-  Το παρόν εγχειρίδιο αποτελεί αναπόσπαστο μέρος του προϊόντος: βεβαιωθείτε ότι βρίσκεται πάντοτε μαζί με τα εργαλεία της συσκευής, ακόμη και σε περίπτωση παραχώρησης σε άλλον ιδιοκτήτη ή χρήστη ή μεταφοράς σε άλλο σύστημα. Σε περίπτωση φθοράς ή απώλειας, ζητήστε ένα άλλο αντίγραφο από την Υπηρεσία Τεχνικής Υποστήριξης της περιοχής σας.
-  Η συσκευή μπορεί να χρησιμοποιηθεί από παιδιά ηλικίας κάτω των 8 ετών και από άτομα με μειωμένες σωματικές, αισθητηριακές ή διανοητικές ικανότητες ή με έλλειψη εμπειρίας ή απαραίτητων γνώσεων, υπό την προϋπόθεση ότι βρίσκονται υπό επίτηρηση ή αφού έχουν λάβει οδηγίες σχετικά με την ασφαλή χρήση της συσκευής και την κατανόηση των κινδύνων που είναι εγγενείς σε αυτήν. Τα παιδιά δεν πρέπει να παίζουν με τη συσκευή. Ο καθαρισμός και η συντήρηση που πρέπει να γίνεται από τον χρήστη δεν πρέπει να πραγματοποιούνται από παιδιά χωρίς επίβλεψη.
-  Ο λέβητας είναι κατάλληλος για χρήση με αέρια καυσίμου της ομάδας H ή/και της ομάδας E και μείγματα φυσικού αερίου και υδρογόνου έως 20% κατ' όγκο.
-  Η εγκατάσταση του λέβητα και οποιαδήποτε άλλη λειτουργία υποβοήθησης και συντήρησης πρέπει να εκτελούνται από εξειδικευμένο προσωπικό σύμφωνα με τους ισχύοντες κανονισμούς και σύμφωνα με το UNI 7129-7131 και τις ενημερώσεις.
-  Η συντήρηση του λέβητα πρέπει να γίνεται τουλάχιστον μία φορά ετησίως και να προγραμματίζεται έγκαιρα με την Υπηρεσία Τεχνικής Υποστήριξης.
-  Ο υπεύθυνος της εγκατάστασης πρέπει να εξηγήσει στον χρήστη τη λειτουργία της συσκευής και τους θεμελιώδεις κανόνες ασφάλειας.
-  Ο χρήστης πρέπει να ακολουθεί τις προειδοποιήσεις που παρέχονται στο παρόν εγχειρίδιο.
-  Αυτός ο λέβητας πρέπει να προορίζεται μόνο για τη χρήση για την οποία έχει κατασκευαστεί. ΔΕΝ περιλαμβάνεται καμία συμβατική ή εξωσυμβατική υπευθυνότητα του κατασκευαστή για ζημιές που προκαλούνται σε άτομα, ζώα ή αντικείμενα, εξαιτίας σφαλμάτων στην εγκατάσταση, ρύθμιση, συντήρηση και λόγω ακατάλληλης χρήσης.
-  Αφού αφαιρέσετε το περιτύλιγμα, βεβαιωθείτε για την ακεραιότητα και την πληρότητα του περιεχομένου. Σε αντίθετη περίπτωση, απευθυνθείτε στο σημείο πώλησης όπου αγοράσατε τη συσκευή.
-  Η εξαγωγή της βαλβίδας ασφαλείας της συσκευής πρέπει να συνδέεται σε ένα κατάλληλο σύστημα συλλογής και εκκένωσης. Ο κατασκευαστής της συσκευής δεν φέρει ευθύνη για τυχόν ζημιές που μπορεί να προκληθούν από τη λειτουργία της βαλβίδας ασφαλείας.
-  Η διάθεση των υλικών συσκευασίας πρέπει να γίνεται στους ειδικούς κάδους στα κατάλληλα κέντρα συλλογής.
-  Τα απορρίμματα πρέπει να διατίθενται χωρίς κίνδυνο για την ανθρώπινη υγεία και χωρίς διαδικασίες ή μεθόδους που μπορεί να βλάψουν το περιβάλλον.
-  Το προϊόν στο τέλος της διάρκειας ζωής του δεν πρέπει να απορρίπτεται ως στερεό αστικό απόρριμμα αλλά να παραδίδεται σε ένα κέντρο ανακύκλωσης.

Κατά τη διάρκεια της εγκατάστασης θα πρέπει να ενημερώσετε το χρήστη για τα εξής:











- σε περίπτωση διαρροής νερού, κλείστε την τροφοδοσία νερού και ειδοποιήστε άμεσα την Υπηρεσία Τεχνικής Υποστήριξης
- Πρέπει κατά διαστήματα να βεβαιώνεται ότι η πίεση λειτουργίας της υδραυλικής εγκατάστασης είναι υψηλότερη από 1 bar. Εάν είναι απαραίτητο, αποκαταστήστε την πίεση ανοίγοντας τη βάνα πλήρωσης (**ενότητα 9 - βλέπε «Διάταξη λέβητα»**)
- περιμένετε μέχρι να αυξηθεί η πίεση: ελέγξτε στην οθόνη του λέ-

βητα ότι η τιμή φτάνει τα 1-1,5 bar. Τότε κλείστε ξανά τη βάνα πλήρωσης (**ενότητα 9 - βλέπε «Διάταξη λέβητα»**).

Σε περίπτωση μη χρήσης του λέβητα για μεγάλη περίοδο συνιστάται να γίνουν οι ακόλουθες εργασίες:

- τοποθετήστε τη συσκευή σε κατάσταση OFF και τον γενικό διακόπτη της εγκατάστασης σε κατάσταση «σβηστό»
- κλείστε τις βάνες του καυσίμου και του νερού, είτε της εγκατάστασης θέρμανσης ή της εγκατάστασης ζεστού νερού χρήσης
- να αδειάσει το σύστημα θέρμανσης και το σύστημα οικιακής χρήσης αν υπάρχει κίνδυνος παγώματος.

Για την ασφάλεια θα πρέπει να θυμόσαστε ότι:

-  Απαγορεύεται η ενεργοποίηση των μηχανημάτων ή ηλεκτρικών συσκευών, όπως διακόπτες, ηλεκτρικές οικιακές συσκευές κ.τ.λ., αν αντληφθείτε οσμή καυσίμου ή ατελή καύση. Σε αυτή την περίπτωση:
 - Αερίστε το χώρο ανοίγοντας πόρτες και παράθυρα
 - Κλείστε τη διάταξη διακοπής καυσίμου
 - Ζητήστε την άμεση επέμβαση της Υπηρεσίας Τεχνικής Υποστήριξης ή επαγγελματικά καταρτισμένου προσωπικού.
-  Απαγορεύεται να αγγίζετε τη συσκευή αν έχετε γυμνά πόδια ή είστε βρεγμένοι.
-  Απαγορεύεται οποιαδήποτε τεχνική επέμβαση ή εργασία καθαρισμού αν πρώτα δεν αποσυνδέσετε τη συσκευή από το δίκτυο ηλεκτρικής τροφοδοσίας τοποθετώντας την κατάσταση του λέβητα στο «OFF» και τον γενικό διακόπτη της εγκατάστασης στο «σβηστός».
-  Απαγορεύεται η τροποποίηση των συστημάτων ασφαλείας ή ρύθμισης χωρίς την εξουσιοδότηση ή τις υποδείξεις του κατασκευαστή της συσκευής.
-  Απαγορεύεται να τραβάτε, αποσυνδέετε, συστρέψετε τα ηλεκτρικά καλώδια που βγαίνουν εκτός της συσκευής ακόμη και αν είναι αποσυνδεδεμένη από το δίκτυο ηλεκτρικής τροφοδοσίας.
-  Μην φράζετε ή μειώνετε τις διαστάσεις των οπών αερισμού του χώρου εγκατάστασης.
-  Μην αφήνετε δοχεία και εύφλεκτες ουσίες στον χώρο όπου είναι εγκατεστημένη η συσκευή.
-  Απαγορεύεται να διασκορπίζετε στο περιβάλλον και να αφήνετε κοντά σε παιδιά τα υλικά συσκευασίας γιατί μπορεί να αποτελέσουν πιθανή πηγή κινδύνου. Συνεπώς, πρέπει να απορρίπτονται σύμφωνα με την ισχύουσα νομοθεσία.
-  Απαγορεύεται να φράζετε την εκκένωση συμπτκνώματος. Ο αγωγός εκκένωσης συμπτκνωμάτων πρέπει να είναι στραμμένος προς τον αγωγό εκκένωσης, αποφεύγοντας τον σχηματισμό πρόσθετων σιφονιών.
-  Απαγορεύεται η επέμβαση στη βαλβίδα αερίου με οποιονδήποτε τρόπο.
-  Απαγορεύεται η παρέμβαση στα σφραγισμένα στοιχεία.

2 ΠΕΡΙΓΡΑΦΗ

Οι λέβητες **RESIDENCE AQUA HM BIS** διαθέτουν νέο σύστημα ελέγχου καύσης ACC (ενεργός έλεγχος καύσης). Αυτό το καινοτόμο σύστημα ελέγχου, που αναπτύχθηκε από την Riello, εγγυάται λειτουργικότητα, απόδοση και χαμηλές εκπομπές ρύπων σε όλες τις περιπτώσεις. Το σύστημα ACC χρησιμοποιεί έναν αισθητήρα ιονισμού βυθισμένο στη φλόγα του καυστήρα, ο οποίος, μέσω των πληροφοριών του, επιτρέπει στον πίνακα ελέγχου να ενεργεί στη βαλβίδα αερίου που ρυθμίζει το καύσιμο. Αυτό το εξελιγμένο σύστημα ελέγχου επιτρέπει την αυτορρύθμιση της καύσης, εξαλείφοντας την ανάγκη για αρχική βαθμονόμηση της βαλβίδας αερίου. Το σύστημα ACC είναι σε θέση να προσαρμόσει τον λέβητα ώστε να λειτουργεί με διαφορετικές συνθέσεις αερίου, διαφορετικά μήκη σωλήνων και διαφορετικά υψόμετρα (εντός των αναμενόμενων ορίων σχεδιασμού). Το σύστημα ACC είναι επίσης σε θέση να πραγματοποιήσει μια αυτοδιάγνωση που μπλοκάρει τον καυστήρα πριν ξεπεράσει τα όρια εκπομπών υψηλότερα από τα όρια που επιτρέπονται από τους κανονισμούς.

3 ΤΕΧΝΙΚΑ ΧΑΡΑΚΤΗΡΙΣΤΙΚΑ

ΠΕΡΙΓΡΑΦΗ	UM	25 HM BIS			35 HM BIS		
		G20	G31	G20	G31		
Θέρμανση	Ονομαστική θερμική παροχή	kW-kcal/h	20,00-17.200		30,00-25.800		
	Ονομαστική θερμική ισχύς (80°/60°)	kW-kcal/h	19,53-16.799		29,28-25.181		
	Ονομαστική θερμική παροχή (50°/30°)	kW-kcal/h	21,31-18.323		31,75-27.302		
	Μειωμένη θερμική παροχή	kW-kcal/h	2,50-2.150	-	3,50-3.010	-	
	Μειωμένη θερμική ισχύς (80°/60°)	kW-kcal/h	2,34-2.009	-	3,36-2.891	-	
	Μειωμένη θερμική ισχύς (50°/30°)	kW-kcal/h	2,57-2.213	-	3,71-3.191	-	
ZNX	Ονομαστική θερμική παροχή	kW-kcal/h	25,00-21.500 I2Y20: 24,00-20.640		34,90-30.014		
	Ονομαστική θερμική ισχύς (*)	kW-kcal/h	25,00-21.500		34,90-30.014		
	Μειωμένη θερμική παροχή	kW-kcal/h	2,50-2.150	-	3,50-3.010	-	
	Μειωμένη θερμική ισχύς (*)	kW-kcal/h	2,50-2.150	-	3,50-3.010	-	
Ωφέλιμη απόδοση Pn max - Pn min (80°/60°)	%		97,7-93,5		97,6-96,0		
Απόδοση καύσης	%		98,0		97,8		
Ωφέλιμη απόδοση Pn max - Pn min (50°/30°)	%		106,5-102,9		105,8-106,0		
Ωφέλιμη απόδοση 30% Pn max (30° επιστροφή)	%		109,7		109,7		
Συνολική ηλεκτρική ισχύς (μέγιστη ισχύς θέρμανσης - ZNX)	W		73-87		87-110		
Ηλεκτρική ισχύς κυκλοφορητή (1.000 λίτρα/ώρα)	W		43		43		
Κατηγορία • Χώρα προορισμού			I12HY203P • GR		I12HY203P • GR		
Τάση τροφοδοσίας	V-Hz		230-50		230-50		
Βαθμός προστασίας	IP		X5D		X5D		
Απώλειες κατά τη διακοπή	W		30		35		
Απώλειες στην καμινάδα με σβησμένο - αναμμένο καυστήρα	%		0,09-2,04		0,07-2,17		
Λειτουργία θέρμανσης							
Μέγιστη πίεση	bar		3		3		
Ελάχιστη θερμοκρασία για στάνταρ λειτουργία	bar		0,25±0,45		0,25±0,45		
Μέγιστη θερμοκρασία	°C		90		90		
Πεδίο επιλογής της θερμοκρασίας θέρμανσης	°C		40-80 (υψηλός) 20-45 (χαμηλός)		40-80 (υψηλός) 20-45 (χαμηλός)		
Αντλία: μέγιστο διαθέσιμο ύψος άντλησης για την εγκατάσταση στην παροχή	mbar		450		450		
Δοχείο διαστολής από μεμβράνη	l/h		1.000		1.000		
Πλήρωση δοχείου διαστολής (θέρμανση)	l		9		9		
	bar		1		1		
Λειτουργία ZNX							
Μέγιστη πίεση	bar		8		8		
Ελάχιστη πίεση	bar		0,5		0,5		
Ποσότητα ζεστού νερού με Δt 25° C	l/min		14,3		20,0		
	l/min		11,9		16,7		
	l/min		10,2		14,3		
Ελάχιστη παροχή ζεστού νερού χρήσης	l/min		2		2		
Πεδίο επιλογής της θερμοκρασίας του ζεστού νερού χρήσης H2O	°C		37-60		37-60		
Ρυθμιστής ροής	l/min		14		14		
Πίεση αερίου							
Ονομαστική πίεση φυσικού αερίου (G20 - I2H)	mbar	20	-	-	20	-	
Ονομαστική πίεση MTN-H (G20.2 - I2Y20)	mbar	-	20	-	-	20	
Ονομαστική πίεση LPG (G31-I3P)	mbar	-	-	37	-	-	
Παροχές θέρμανσης			G20	G31	G20	G31	
Παροχή αέρα	Nm³/h		24,804	24,819	37,206	37,581	
Παροχή καπνών	Nm³/h		26,811	26,370	40,216	39,908	
Μέγιστη παροχή καπνών (max-min)	g/s		9,267-1,158	9,297-1,162	13,900-1,622	14,072-1,627	
Παροχές ZNX			G20	G31	G20	G31	
Παροχή αέρα	Nm³/h		31,005	31,024	43,284	43,719	
Παροχή καπνών	Nm³/h		33,513	32,963	46,784	46,426	
Μέγιστη παροχή καπνών (max-min)	g/s		11,584-1,158	11,621-1,162	16,171-1,622	16,370-1,627	
Απόδοση ανεμιστήρα							
Υπολειπόμενο μανομετρικό ύψος ομόκεντρων σωλήνων 0,85 m	Pa		60		60		
Υπολειπόμενο μανομετρικό ύψος ομόκεντρων σωλήνων 0,5 m	Pa		180		195		
Υπολειπόμενο μανομετρικό ύψος χωρίς σωλήνες	Pa		186		199		
Nox			τάξη 6		τάξη 6		
Μέγιστη επιτρεπόμενη τιμή εκπομπής (**)			G20	G31	G20	G31	
Qn-Qr	CO (0% O2) λιγότερο από	p.p.m.	230-15	250-20	240-15	240-20	
	CO2 (***)	%	8,8-8,8	10,0-10,0	8,8-8,8	9,9-10,0	
	NOx (0% O2) λιγότερο από	p.p.m.	40-30	50-50	30-30	40-40	
	καυσαέριο θερμοκρασίας	°C	79-60	78-60	82-60	70-57	
Τιμή O2 σε σχέση με το μείγμα υδρογόνου 20%	Qmax	max	%	2,4		2,4	
		nominal	%	4,3		4,3	
		min	%	6,2		6,2	
	Qmin	max	%	2,4		2,4	
		nominal	%	4,3		4,3	
		min	%	6,2		6,2	

(*) Μέση τιμή ανάμεσα σε διάφορες καταστάσεις λειτουργίας με ζεστό νερό χρήσης

(**) Δοκιμή που πραγματοποιήθηκε με ομόκεντρο σωλήνα Ø60-100, μήκους 0,85 m. - σε λειτουργία θέρμανσης θερμοκρασίες νερού 80-60°C - τιμές μετρημένες με εντελώς κλειστό περίβλημα. Ανάλογα με τον τύπο του συστήματος καπνοδόχου, οι τιμές CO ενδέχεται να διαφέρουν από τις δηλωμένες. Εάν το επίπεδο υπερβαίνει τα 500 ppm, ζητήστε άμεσα παρέμβαση από την Τεχνική Υπηρεσία Υποστήριξης

(***)Ανοχή CO2= ±1%

Τα στοιχεία που αναγράφονται δεν πρέπει να χρησιμοποιούνται για την πιστοποίηση του συστήματος. Για την πιστοποίηση πρέπει να χρησιμοποιούνται τα στοιχεία που αναφέρονται στο "Φυλλάδιο του Συστήματος" η μέτρηση των οποίων έγινε κατά την πρώτη ενεργοποίηση.

ΤΙΜΕΣ ΑΠΟΔΟΣΗΣ ACS ΜΕ ΜΠΟΙΛΕΡ ΣΕ ΠΕΡΙΠΤΩΣΗ ΕΓΚΑΤΑΣΤΑΣΗΣ ΣΕΤ DOSSERET (ΔΙΑΤΙΘΕΤΑΙ ΚΑΤΟΠΙΝ ΑΙΤΗΜΑΤΟΣ)

Περιγραφή		25 HM BIS	35 HM BIS
Τύπος μπόιλερ	∅	Ανοξείδωτος χάλυβας	Ανοξείδωτος χάλυβας
Ρύθμιση μπόιλερ	∅	Κάθετη	Κάθετη
Διάταξη εναλλάκτη	∅	εξωτερική με πλάκες	εξωτερική με πλάκες
Υπομ, πραγματική περιεκτικότητα σε ZNX	I	31	31
Πεδίο επιλογής θερμοκρασίας ZNX	°C	37-60	37-60
Ποσότητα νερού που λαμβάνεται σε 10 λεπτά με ελάχιστη Δt 30°C	l	119	167
Μέγιστη πίεση λειτουργίας μπόιλερ	bar	10	10
VBU, μη ηλιακός όγκος αποθήκευσης	l	31	31
Ειδική παροχή σύμφωνα με το πρότυπο EN13203-1	l/min	14,3	18,1

ΠΑΡΑΜΕΤΡΟΙ	UM	ΑΕΡΙΟ ΜΕΘΑΝΙΟΥ (G20)		ΥΓΡΑΕΡΙΟ (G31)	
Κατώτερος δείκτης Wobbe (15°C-1013 mbar)	MJ/m³S	45,67		70,69	
Κατώτατη θερμαντική ισχύς	MJ/m³S	34,02		88	
Ονομαστική τιμή πίεσης τροφοδοσίας	mbar (mm H2O)	20 (203,9)		37 (377,3)	
Ελάχιστη τιμή πίεσης τροφοδοσίας	mbar (mm H2O)	13 (132,6)		-	
		25 HM BIS	35 HM BIS	25 HM BIS	35 HM BIS
Καυστήρας: διάμετρος/μήκος	mm	70/80,5	70/95	70/80,5	70/95
Μέγιστη παροχή αερίου θέρμανσης	Sm³/h	2,12	3,17	-	-
	kg/h	-	-	1,55	2,33
Μέγιστη παροχή αερίου ζεστού νερού χρήσης	Sm³/h	2,64	3,69	-	-
	kg/h	-	-	1,94	2,71
Ελάχιστη παροχή αερίου θέρμανσης	Sm³/h	0,26	0,37	-	-
	kg/h	-	-	0,19	0,27
Ελάχιστη παροχή αερίου ζεστού νερού χρήσης	Sm³/h	0,26	0,37	-	-
	kg/h	-	-	0,19	0,27
Μέγιστος αριθμός στροφών ανεμιστήρα (θέρμανσης)	rpm	6.300	7.400	6.100	7.100
Μέγιστος αριθμός στροφών ανεμιστήρα (ZNX)	rpm	7.900	8.600	7.600	8.200
Ελάχιστος αριθμός στροφών ανεμιστήρα (θέρμανσης - ZNX)	rpm	1.200	1.300	1.250	1.250
Μέγιστος αριθμός στροφών ανεμιστήρα (θέρμανσης) σε διαμόρφωση C(10)3 (Ø80/125 • Ø80-80)	rpm	6.500	7.600	-	-
Μέγιστος αριθμός στροφών ανεμιστήρα (ZNX) σε διαμόρφωση C(10)3 (Ø80/125 • Ø80-80)	rpm	8.100	8.600	-	-
Ελάχιστος αριθμός στροφών ανεμιστήρα (θέρμανσης - ZNX) σε διαμόρφωση C(10)3 (Ø80/125 • Ø80-80)	rpm	2.100	2.200	-	-

ΣΗΜΕΙΩΣΗ: στις πρώτες 10 ώρες λειτουργίας του καυστήρα, το ελάχιστο δεν θα πέσει ποτέ κάτω από τις 1400 rpm (και για τα 25 και 35 kW); 1600 rpm αν υπαεριο.

Περιγραφή	Τύπος λέβητα RESIDENCE AQUA HM BIS					
	25 BIS	35 BIS	25 BIS	35 BIS	25 BIS	35 BIS
	C4		C6		C8	
Τεχνικά στοιχεία για τυπικές εγκαταστάσεις:						
Θερμοκρασία προϊόντων καύσης @ Ονομαστική απόδοση θερμότητας (στους 80/60°C) - [°C]	63	63,8	63,5	63,9	49,7	56,3
Ρυθμός ροής μάζας [kg/h] @ Ονομαστική ισχύς θερμότητας [kW]	2,759	3,823	2,743	4,089	2,833	3,944
Ονομαστική θερμική ισχύς [kW]	25,8	35,67	25,55	38,4	26,46	36,82
Υπερθερμοκρασία των προϊόντων καύσης [°C]			115			
Θερμοκρασία των καυσαερίων στην ελάχιστη απόδοση θερμότητας [°C]	35,6	39,5	57,6	60,1	35,8	37,4
Ρυθμός ροής μάζας [kg/h] @ Ελάχιστη ισχύς θερμότητας [kW]	0,545	0,694	0,305	0,422	1,036	1,187
Ελάχιστη ισχύς θερμότητας [kW]	5,14	6,52	2,87	4	9,74	11,1
Περιεκτικότητα CO ₂ @ Ονομαστική απόδοση θερμότητας [%]	8,42	8,56	10,00	10,40	5,62	5,92
CO ₂ στην ελάχιστη απόδοση θερμότητας [%]	3,12	3,04	9,08	9,26	2,65	2,56
Απώλεια ελάχιστης επιτρεπόμενης πίεσης (σε τροφοδοσία αέρα και σωλήνα καυσαερίων) [Pa]	4,4	8,3	-	-	-	-
Απώλεια μέγιστης επιτρεπόμενης πίεσης (στον αγωγό παροχής αέρα και καυσαερίων) [Pa]	180	195	-	-	-	-
Μέγιστη επιτρεπόμενη διαφορά πίεσης μεταξύ εισόδου αέρα καύσης και εξόδου καυσαερίων (συμπεριλαμβανομένης της πίεσης ανέμου) [Pa]	-	-	4,4	8,3	-	-
Μέγιστη επιτρεπόμενη θερμοκρασία αέρα καύσης [°C]	-	-	45	45	-	-
	C9	25 BIS - 35 BIS				
Ελάχιστη ωφέλιμη διάμετρος του καπναγωγού/κατακόρυφου τεχνικού διαμερίσματος για την παροχή αέρα καύσης [mm]		240				

Σημείωση

- C1:** για την εγκατάσταση των ακροδεκτών τοίχου και οροφής ανατρέξτε στις ειδικές οδηγίες που περιέχονται στα kit οι ακροδέκτες εξέρχονται από ξεχωριστά κυκλώματα καύσης και παροχής αέρα εντός τετραγώνου 50 cm
- C3:** οι ακροδέκτες των χωριστών κυκλωμάτων καύσης και παροχής αέρα πρέπει να βρίσκονται εντός τετραγώνου 50 cm και η απόσταση μεταξύ των επιπέδων των δύο στοίμων πρέπει να είναι μικρότερη από 50 cm
- C4:** οι λέβητες αυτής της διαμόρφωσης με τους αγωγούς σύνδεσής τους είναι κατάλληλοι για σύνδεση σε μία μόνο καμινάδα φυσικού ελκυσμού δεν επιτρέπεται ροή συμπυκνωμάτων στη συσκευή
- C5:** οι ακροδέκτες για την παροχή αέρα καύσης και την εκκένωση των προϊόντων καύσης δεν πρέπει να εγκαθίστανται σε απέναντι τοίχους του κτιρίου
- C6:** επιτρέπεται η ροή συμπυκνωμάτων στη συσκευή
 μέγιστο επιτρεπόμενο ποσοστό ανακυκλοφορίας 10% σε συνθήκες ανέμου
 οι ακροδέκτες για την παροχή αέρα καύσης και την εκκένωση των προϊόντων καύσης δεν πρέπει να εγκαθίστανται σε απέναντι τοίχους του κτιρίου η συσκευή δεν πρέπει να συνδέεται σε κοινή καπνοδόχο (δηλαδή περισσότερες από μία συσκευές σε κοινή καπνοδόχο) που λειτουργεί υπό θετική πίεση.
- C8:** δεν επιτρέπεται η ροή συμπυκνωμάτων στη συσκευή
- ⚠ Αυτός ο τύπος διαμόρφωσης δεν επιτρέπεται σε ορισμένες χώρες - ανατρέξτε στους ισχύοντες τοπικούς κανονισμούς**

3.1 Στοιχεία Erp

Παράμετρος	Σύμβολο	25 HM BIS	35 HM BIS	Μονάδα
Τάξη ενεργειακής απόδοσης της εποχιακής θέρμανσης χώρου	-	A	A	-
Τάξη ενεργειακής απόδοσης θέρμανσης νερού	-	A	A	-
Ονομαστική ισχύς	Prated	20	29	kW
Ενεργειακή απόδοση της εποχιακής θέρμανσης χώρου	ηs	94	94	%
Ωφέλιμη θερμική ισχύς				
Σε ονομαστική θερμική ισχύ και καθεστώς υψηλής θερμοκρασίας (*)	P4	19,5	29,3	kW
Στο 30% της ονομαστικής θερμικής ισχύος και καθεστώς χαμηλής θερμοκρασίας (**)	P1	6,6	9,9	kW
Ωφέλιμη απόδοση				
Σε ονομαστική θερμική ισχύ και καθεστώς υψηλής θερμοκρασίας (*)	η4	87,9	87,9	%
Στο 30% της ονομαστικής θερμικής ισχύος και καθεστώς χαμηλής θερμοκρασίας (**)	η1	98,8	98,8	%
Βοηθητική κατανάλωση ηλεκτρικής ενέργειας				
Υπό πλήρες φορτίο	elmax	30,0	44,3	W
Υπό μερικό φορτίο	elmin	12,2	13,6	W
Σε κατάσταση αναμονής	PSB	3,0	3,0	W
Άλλες παράμετροι				
Απώλειες θερμότητας σε αναμονή	Pstby	30,0	35,0	W
Κατανάλωση ενέργειας της φλόγας οδηγού	Pign	-	-	W
Ετήσια κατανάλωση ενέργειας	QHE	60	90	GJ
Στάθμη ηχητικής ισχύος εσωτερικού χώρου	LWA	48	47	dB
Εκπομπές οξειδίων του αζώτου	NOx	22	35	mg/kWh
Για θερμαντήρες συνδυασμένης λειτουργίας				
Δηλωμένο προφίλ φορτίου		XL	XL	
Ενεργειακή απόδοση θέρμανσης νερού	ηwh	85	87	%
Ημερήσια κατανάλωση ηλεκτρικής ενέργειας	Qelec	0,173	0,102	kWh
Ημερήσια κατανάλωση καυσίμου	Qfuel	23,014	22,524	kWh
Ετήσια κατανάλωση ηλεκτρικής ενέργειας	AEC	38	22	kWh
Ετήσια κατανάλωση καυσίμου	AFC	17	17	GJ

(*) καθεστώς υψηλής θερμοκρασίας: θερμοκρασία επιστροφής 60°C και θερμοκρασία τροφοδοσίας του λέβητα 80°C

(**) καθεστώς χαμηλής θερμοκρασίας: για λέβητες συμπύκνωσης 30°C, για λέβητες χαμηλής θερμοκρασίας 37°C, για άλλους θερμαντήρες θερμοκρασία επιστροφής 50°C



Για τις συνδυασμένες συσκευές θέρμανσης: ΛΕΒΗΤΑΣ ΜΕ DOSSERET

Παράμετρος	Σύμβολο	25 HM BIS	35 HM BIS	Μονάδα
Προφίλ φορτίου		XL	XL	
Ημερήσια κατανάλωση ηλεκτρικής ενέργειας	Qelec	0,352	0,354	kWh
Ετήσια κατανάλωση ηλεκτρικής ενέργειας	AEC	77	78	kWh
Ενεργειακή απόδοση θέρμανσης νερού	ηwh	80	82	%
Ημερήσια κατανάλωση καυσίμου	Qfuel	23,964	23,370	kWh
Ετήσια κατανάλωση καυσίμου	AFC	18	18	GJ

(*) καθεστώς υψηλής θερμοκρασίας: θερμοκρασία επιστροφής 60°C και θερμοκρασία τροφοδοσίας του λέβητα 80°C

(**) καθεστώς χαμηλής θερμοκρασίας: για λέβητες συμπύκνωσης 30°C, για λέβητες χαμηλής θερμοκρασίας 37°C, για άλλους θερμαντήρες θερμοκρασία επιστροφής 50°C

RIELLO		RIELLO S.p.A. - Via Ing. Pilade Riello, 7 - 37045 Legnago (Vr)			
RESIDENCE AQUA HM BIS		D: l/min		Q _{nw}	Q _n
Serial N.		COD.		Q _m	Q _n
230 V ~ 50 Hz W		NOx:		80-60 °C	50-30 °C
P _{mw} = bar T = °C		IP		Q _n (Hi) = kW	kW
P _{ms} = bar T = °C		P _n =		kW	kW

EL	
Q _{nw}	Ονομαστική παροχή ζεστού νερού χρήσης
Q _n	Ονομαστική παροχή θέρμανσης
Q _m	Ελάχιστη παροχή θέρμανσης
Q _n (Hi)	Ονομαστική παροχή (χαμηλότερη θερμογόνος δύναμη)
P _n	Ονομαστική ισχύς
 P _{ms}	Μέγιστη πίεση λειτουργίας θέρμανσης
 P _{mw}	Μέγιστη πίεση λειτουργίας ζεστού νερού χρήσης
T	Θερμοκρασία
IP	Βαθμός προστασίας
NO _x	Κατηγορία NO _x
D	Ειδική παροχή

4 ΕΓΚΑΤΑΣΤΑΣΗ

4.1 Καθαρισμός εγκατάστασης και χαρακτηριστικά νερού

Σε περίπτωση νέας εγκατάστασης ή αντικατάστασης του λέβητα, η εγκατάσταση θέρμανσης πρέπει πρώτα να καθαριστεί. Προκειμένου να εξασφαλιστεί η καλή λειτουργία του προϊόντος, μετά από κάθε εργασία καθαρισμού, προσθήκης πρόσθετων ή/και χημικών επεξεργασιών (π.χ. αντιψυκτικό υγρό, επικάλυψη με λεπτό υμένω, κλπ. ...), βεβαιωθείτε ότι οι παράμετροι στον πίνακα περιλαμβάνονται στις υποδεικνυόμενες τιμές.

ΠΑΡΑΜΕΤΡΟΙ	μ.μ.	ΝΕΡΟ ΚΥΚΛΩΜΑΤΟΣ ΘΕΡΜΑΝΣΗΣ	ΝΕΡΟ ΠΛΗΡΩΣΗΣ
Τιμή PH	-	7-8	-
Σκληρότητα	°F	-	<15
Οψη	-	-	διαυγές
Fe	mg/kg	<0,5	-
Cu	mg/kg	<0,1	-

Ο λέβητας πρέπει να συνδεθεί με μια εγκατάσταση θέρμανσης και ένα δίκτυο ζεστού νερού χρήσης, τα οποία θα πρέπει να διαστασιολογηθούν ανάλογα με τις επιδόσεις και την ισχύ του.

Πριν από την εγκατάσταση, συνιστάται να πλύνετε καλά όλες τις σωληνώσεις του συστήματος για να αφαιρεθούν τυχόν υπολείμματα που θα μπορούσαν να εμποδίσουν τη σωστή λειτουργία της συσκευής. Εγκαταστήστε κάτω από τη βαλβίδα ασφαλείας ένα χωνί συλλογής νερού με την αντίστοιχη εκκένωση σε περίπτωση διαρροής λόγω υπερπίεσης του συστήματος θέρμανσης. Το κύκλωμα ζεστού νερού χρήσης δεν χρειάζεται βαλβίδα ασφαλείας, αλλά θα πρέπει να βεβαιώνετε ότι η πίεση του οχετού δεν υπερβαίνει τα 6 bar. Εάν δεν είστε βέβαιοι θα πρέπει να εγκαταστήσετε έναν μειωτήρα πίεσης.



Πριν από την έναυση, βεβαιωθείτε ότι ο λέβητας είναι σχεδιασμένος για λειτουργία με το διαθέσιμο αέριο. Αυτό αναγράφεται στην επιγραφή της συσκευασίας και στην αυτοκόλλητη ετικέτα που αναφέρει την τυπολογία του αερίου.



Θα πρέπει να δοθεί έμφαση στο γεγονός ότι σε ορισμένες περιπτώσεις οι καπνοδόχοι λειτουργούν υπό πίεση και άρα οι ενώσεις των διαφόρων στοιχείων θα πρέπει να είναι στεγανές.

4.2 Κανόνες εγκατάστασης

Η εγκατάσταση πρέπει να πραγματοποιείται από εξειδικευμένο προσωπικό σύμφωνα με τα ακόλουθα πρότυπα:

- UNI 7129-7131, CEI 64-8.



Κατά τη διάρκεια της εγκατάστασης του λέβητα, συνιστάται η χρήση προστατευτικού ρουχισμού για την αποφυγή τραυματισμών.

Επίσης, θα πρέπει πάντοτε να τηρείτε τους τοπικούς κανονισμούς της Πυροσβεστικής, της Εταιρείας Αερίου και άλλες κοινοτικές διατάξεις.

ΤΟΠΟΘΕΣΙΑ

Αυτός ο λέβητας συμπύκνωσης τύπου C έχει σχεδιαστεί για θέρμανση και παραγωγή ζεστού νερού χρήσης και, ανάλογα με τον τύπο της εγκατάστασης, διακρίνεται σε δύο κατηγορίες:

1. λέβητας τύπου B23P-B53P, ανοιχτής αναγκαστικής εγκατάστασης, με αγωγό εκκένωσης καπνών και εισαγωγή αέρα καύσης από τον χώρο στον οποίο εγκαθίσταται;
2. τύπος λέβητα C(10)3; C13,C13x; C33,C33x; C43,C43x; C53,C53x; C63,C63x; C83,C83x; C93,C93x; λέβητας σε στεγανό θάλαμο με αγωγό εκκένωσης καπνών και εισαγωγή αέρα καύσης από εξωτερικό χώρο. Δεν απαιτεί εισαγωγή αέρα στο δωμάτιο όπου είναι εγκατεστημένος.

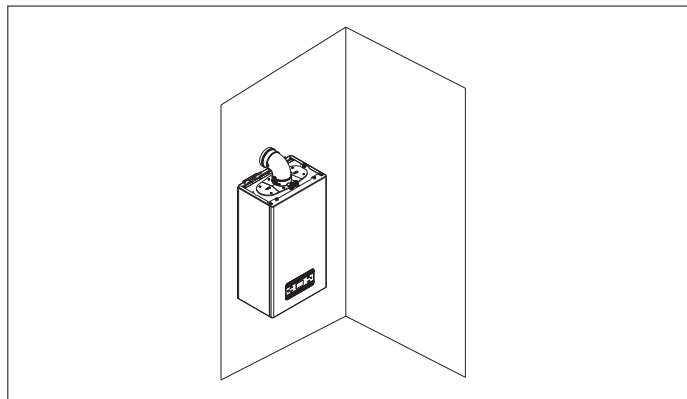

ΑΝΤΙΠΑΓΕΤΙΚΟ ΣΥΣΤΗΜΑ

Ο λέβητας διαθέτει βασικό εξοπλισμό αυτόματου αντιπαγετικού συστήματος, που ενεργοποιείται όταν η θερμοκρασία του νερού στο πρωτεύον κύκλωμα πέσει κάτω από 5°C. Το σύστημα αυτό είναι πάντα ενεργό και εγγυάται την προστασία του λέβητα μέχρι μια θερμοκρασία αέρα στη θέση εγκατάστασης >0°C.



Για να χρησιμοποιηθεί αυτή η προστασία, που βασίζεται στη λειτουργία του καυστήρα, ο λέβητας πρέπει να μπορεί να ανάψει, κατά συνέπεια οποιαδήποτε κατάσταση μπλοκαρίσματος (π.χ. λόγω έλλειψης αερίου ή ηλεκτρικής τροφοδοσίας, ή η επέμβαση μιας ασφάλειας) απενεργοποιεί την προστασία.

Αν το μηχάνημα παραμείνει χωρίς τροφοδοσία για μεγάλα χρονικά διαστήματα σε περιοχές όπου η θερμοκρασία μπορεί να πέσει και κάτω από >0°C και δεν επιθυμείτε να αδειάσετε την εγκατάσταση θέρμανσης, για την αντιψυκτική προστασία του συνιστάται να ζητήσετε να τοποθετηθεί στο πρωτεύον κύκλωμα ένα αντιψυκτικό υγρό καλής μάρκας. Ακολουθήστε προσεκτικά τις οδηγίες του κατασκευαστή σχετικά με το ποσοστό αντιψυκτικού υγρού σε σχέση με την ελάχιστη θερμοκρασία στην οποία θέλετε να διατηρηθεί στο κύκλωμα του μηχανήματος, τη διάρκεια και την απόρριψη του υγρού.

Για το τμήμα ζεστού νερού χρήσης συνιστάται να αδειάσετε το κύκλωμα.

Τα υλικά από τα οποία είναι κατασκευασμένα τα εξαρτήματα των λεβήτων αντέχουν σε ψυκτικά υγρά με βάση την αιθυλενική γλυκόλη.

ΕΛΑΧΙΣΤΕΣ ΑΠΟΣΤΑΣΕΙΣ

Πρόσβαση στο εσωτερικό του λέβητα για τις συνήθεις εργασίες συντήρησης, τηρώντας τις ελάχιστες απαιτήσεις χώρου για την εγκατάσταση.

Τοποθετήστε τη συσκευή, λαμβάνοντας υπόψη ότι:

- πρέπει να εγκατασταθεί σε τοίχο κατάλληλο για να αντέξει το βάρος του
- δεν πρέπει να τοποθετείται πάνω σε κουζίνα ή άλλη συσκευή ψησίματος
- απαγορεύεται να αφήνετε εύφλεκτες ουσίες στον χώρο όπου είναι εγκατεστημένος ο λέβητας.

ΕΛΑΧΙΣΤΕΣ ΑΠΟΣΤΑΣΕΙΣ ΓΙΑ ΤΗ ΣΥΝΤΗΡΗΣΗ

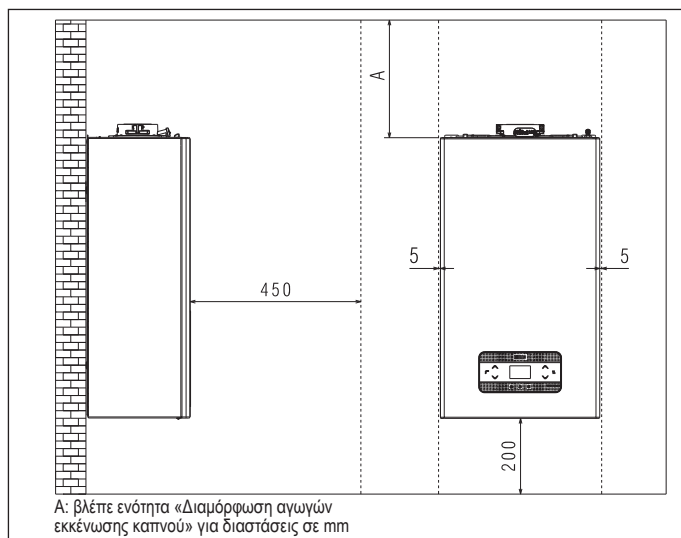

ΕΛΑΧΙΣΤΕΣ ΑΠΟΣΤΑΣΕΙΣ ΓΙΑ ΤΗΝ ΕΓΚΑΤΑΣΤΑΣΗ ΣΕ ΕΡΜΑΡΙΟ

- Τηρείτε απόσταση ασφαλείας μεταξύ του τοίχου στον οποίο είναι εγκατεστημένος ο λέβητας και των θερμών τμημάτων στο εξωτερικό του.

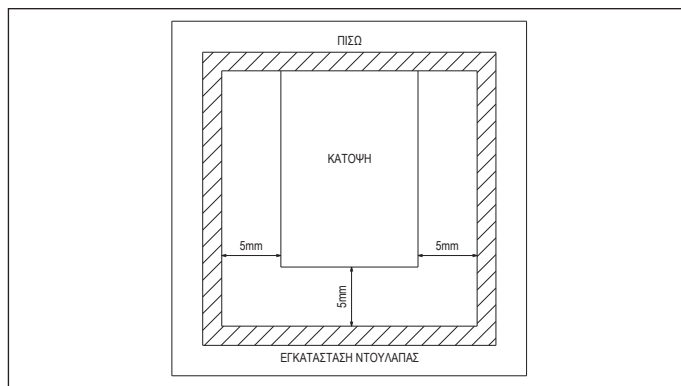

4.3 Σετ Dossieret (διαθέσιμο κατόπιν αιτήματος)

Το σετ Dossieret σε συνδυασμό με τον λέβητα σας επιτρέπει να έχετε ένα απόθεμα νερού πάντα διαθέσιμο στην επιθυμητή θερμοκρασία.

Το σύστημα που αποτελείται από έναν λέβητα με μπόιλερ 30 λίτρων είναι απλό στη συναρμολόγηση: το πρώτο βήμα είναι η εγκατάσταση του επίτοιχου μπόιλερ με την επιλογή εξαρτημάτων ZNX που επιτρέπουν τη σύνδεση με τον λέβητα.

Εγκατάσταση:

- στερεώστε τον σφιγκτήρα για το επίτοιχο dossieret (1)
- στερεώστε τον σφιγκτήρα στερέωσης του λέβητα στο dossieret (2)
- συναρμολογήστε τα σετ υδραυλικών σωλήνων και το κιτ διακόπτη ροής (3) (διαθέσιμο κατόπιν αιτήματος)
- αγκιστρώστε τον λέβητα στον σφιγκτήρα (4)
- εκτελέστε τις υδραυλικές συνδέσεις μεταξύ dossieret και λέβητα
- εκτελέστε την ηλεκτρική σύνδεση μεταξύ του dossieret και του λέβητα.

Ανατρέξτε στις ειδικές οδηγίες του σετ για περισσότερες λεπτομέρειες.

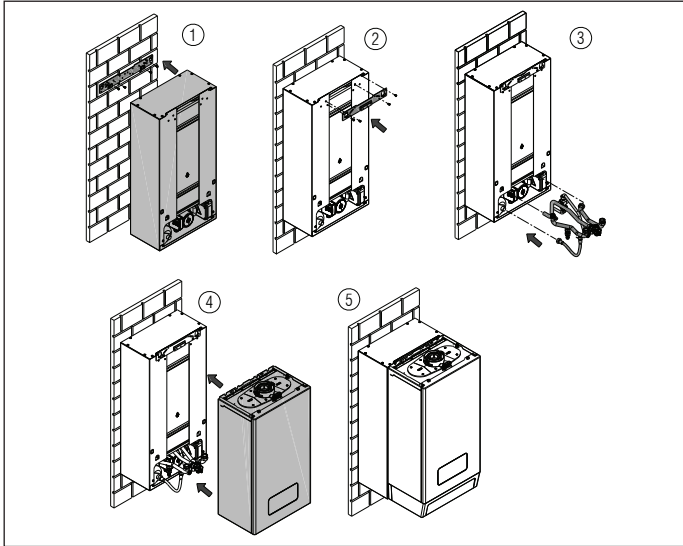

Το μπόιλερ με τεχνολογία αποθήκευσης δύο δεξαμενών έχει την ίδια απόδοση με τα μπόιλερ με πηλία 45 και 60 λίτρων, αλλά με σημαντικά περιορισμένους χώρους. Είναι δυνατόν, μέσω της παραμέτρου στο ηλεκτρονικό σύστημα, να αποκλειστεί η λειτουργία του κυλίνδρου με τη λειτουργία του λέβητα σε στιγμιαία λειτουργία.

P520 = 1 ενεργοποιημένο μπόιλερ, αποθήκευση ZNX

P520 = 0 χωρίς τη λειτουργία μπόιλερ 0, ο λέβητας λειτουργεί σε στιγμιαία λειτουργία, εξοικονομώντας αέριο

Η παράμετρος **P521** διαχειρίζεται τη συχνότητα επαναφοράς του μπόιλερ:

COMFORT οδηγεί τον λέβητα σε μεγαλύτερους και συχνότερους κύκλους πλήρωσης του μπόιλερ. Αυτή η ρύθμιση, για την οποία ο λέβητας έχει σχεδιαστεί με όρους καλύτερης απόδοσης, είναι τυπική για οικιακές εφαρμογές όπου προτιμάται η υγιεινολογική απόδοση του συστήματος.

ECO οδηγεί τον λέβητα σε μειωμένο αριθμό κύκλων πλήρωσης των μπόιλερ. Αυτή η επιλογή πρέπει να γίνει όταν θέλετε μεγαλύτερη εξοικονόμηση ενέργειας, αλλά περιορίζετε την υγιεινολογική απόδοση του συστήματος.

⚠ Αυτές οι παράμετροι πρέπει να ρυθμιστούν πριν από τη χρήση του λέβητα.

⚠ Στην κατάσταση OFF, ο κύκλος επαναφοράς του μπόιλερ είναι απενεργοποιημένος. Ο κύκλος επαναφοράς του μπόιλερ αναστέλλει προσωρινά την εκτέλεση ενός κύκλου θέρμανσης δωματίου.

⚠ Κατά τη διάρκεια ενός κύκλου πλήρωσης του μπόιλερ, η οθόνη του λέβητα δείχνει TCHG (με P105 = 1 ΚΥΛΙΣΗ --> ΦΟΡΤΩΣΗ ΤΟΥ ΣΑΚΙΔΙΟΥ).

⚠ Ένας κύκλος πλήρωσης πραγματοποιείται μετά την ενεργοποίηση, περίπου 3 λεπτά μετά από ένα αίτημα ZNX, μεταξύ της εναλλαγής από την OFF στην κατάσταση ΚΑΛΟΚΑΙΡΙ/ΧΕΙΜΩΝΑΣ, κατά το κλείσιμο του προγραμματιστή χρόνου υγείας (POS).

⚠ Εάν δεν υπάρχει επικοινωνία μεταξύ του πίνακα του λέβητα και του σετ dossier (σύνδεση BUS 485 - για λεπτομέρειες ανατρέξτε στις οδηγίες του σετ dossier), στην οθόνη εμφανίζεται η ένδειξη E066 (με P105 = 1 ΚΥΛΙΣΗ --> Η ΕΠΙΚΟΙΝΩΝΙΑ DOSSERET ΧΑΘΗΚΕ). Ο λέβητας ωθείται στην κατάσταση OFF.

⚠ Σε περίπτωση δυσλειτουργίας του κυκλοφορητή ZNX στο DOSSERET, όπως η ηλεκτρική ή μηχανική απόφραξη του, το σύστημα δεν προβλέπεται σηματοδότηση. Αυτό μπορεί να οδηγήσει τόσο σε υποβάθμιση της απόδοσης ZNX όσο και σε βλάβη του συστήματος θέρμανσης. Η τεχνική υπηρεσία θα μπορεί να απενεργοποιήσει προσωρινά τη λειτουργία DOSSERET (P520=0) για το χρονικό διάστημα που απαιτείται για την αντικατάσταση του κυκλοφορητή ZNX στο DOSSERET.

⚠ Σε περίπτωση βλάβης επικοινωνίας μεταξύ του λέβητα και της πλακέτας ρύθμισης, η λειτουργία επαναφοράς του μπόιλερ διακόπτεται.

Για να ολοκληρώσετε την εγκατάσταση, χρησιμοποιήστε το παρακάτω kit αξεσουάρ:

- υδραυλικό σωλήνες
- διακόπτης ροής με σωλήνες
- κάλυμμα τοποθέτησης
- συμπαγής διανομέας πολυφωσφορικών (σε περίπτωση λέβητα με ενσωματωμένο διανομέα).

Για περισσότερες πληροφορίες, ανατρέξτε στον κατάλογο.

4.4 Οδηγίες σύνδεσης της εκκένωσης συμπυκνώματος

Το προϊόν αυτό έχει σχεδιαστεί για να εμποδίζει τη διαρροή αεριωδών προϊόντων καύσης από τον αγωγό εκκένωσης συμπυκνώματος με τον οποίο είναι εξοπλισμένο, κάτι που επιτυγχάνεται με τη χρήση ενός ειδικού σιφονιού που βρίσκεται στο εσωτερικό της συσκευής.

⚠ Όλα τα εξαρτήματα που αποτελούν το σύστημα αποστράγγισης συμπυκνώματος του προϊόντος πρέπει να συντηρούνται σωστά σύμφωνα με τις οδηγίες του κατασκευαστή και δεν επιτρέπεται να τροποποιούνται με οποιονδήποτε τρόπο.

Η εκκένωση συμπυκνώματος κατάντη της συσκευής πρέπει να συμμορφώνεται με τους σχετικούς ισχύοντες νόμους και κανόνες. Η εγκατάσταση του συστήματος εκκένωσης συμπυκνώματος κατάντη της συσκευής αποτελεί ευθύνη του υπεύθυνου εγκατάστασης. Το σύστημα εκκένωσης συμπυκνώματος πρέπει να διαστασιολογείται και να εγκαθίσταται κατά τρόπο ώστε να εξασφαλίζεται η σωστή εκκένωση του συμπυκνώματος που παράγεται από τη συσκευή ή/και συλλέγεται από τα συστήματα εκκένωσης των προϊόντων καύσης. Όλα τα εξαρτήματα του συστήματος εκκένωσης συμπυκνώματος πρέπει να είναι κατασκευασμένα σύμφωνα με την ορθή πρακτική και από κατάλληλα υλικά, ώστε να αντέχουν τις μηχανικές, θερμικές και χημικές καταπονήσεις του συμπυκνώματος που παράγεται από τη συσκευή με την πάροδο του χρόνου.

Σημείωση: Εάν το σύστημα εκκένωσης συμπυκνώματος είναι εκτεθειμένο στον κίνδυνο παγώματος, να παρέχετε πάντα επαρκές επίπεδο μόνωσης για τον αγωγό και να εξετάζετε το ενδεχόμενο αύξησης της διαμέτρου του αγωγού.

Ο σωλήνας εκκένωσης συμπυκνώματος πρέπει να έχει πάντα επαρκή κλίση για την αποφυγή της στασιμότητας του συμπυκνώματος και την ορθή αποστράγγισή του. Το σύστημα εκκένωσης συμπυκνώματος πρέπει να διαθέτει μια ελεγχόμενη αποσύνδεση μεταξύ του αγωγού εκκένωσης συμπυκνώματος της συσκευής και του συστήματος εκκένωσης συμπυκνώματος.

4.5 Πρόσβαση στα ηλεκτρικά μέρη

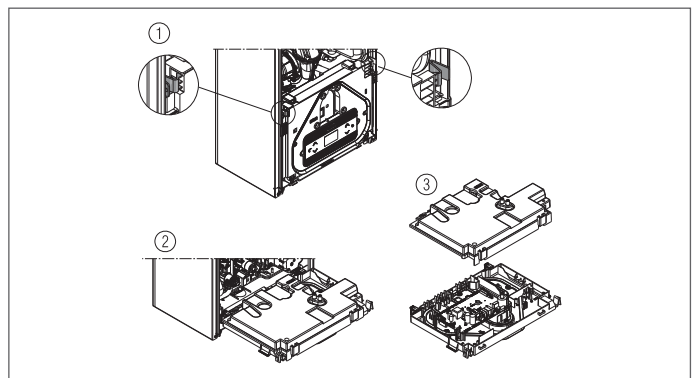

4.6 Ηλεκτρική σύνδεση

Συνδέσεις χαμηλής τάσης

Πραγματοποιήστε τις ηλεκτρικές συνδέσεις χαμηλής τάσης ως εξής:

- χρησιμοποιήστε τα βύσματα που παρέχονται:
 - βύσμα ModBus 4 πόλων για σήμα BUS 485 (- A B +)
 - βύσμα 8 πόλων για σήματα TBT - TA - OT+ - SE

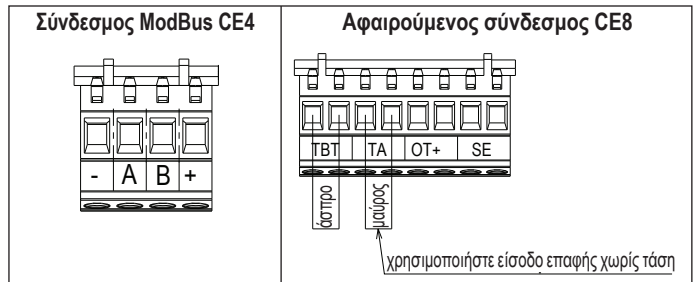

CE4	(- A B +)	Bus 485
CE8	TBT	Θερμοστάτης χαμηλής θερμοκρασίας
	TA	Θερμοστάτης χώρου (επαφή χωρίς τάση)
	OT+	Open therm
	SE	Εξωτερικός αισθητήρας

- πραγματοποιήστε τις ηλεκτρικές συνδέσεις χρησιμοποιώντας το επιθυμητό βύσμα όπως φαίνεται στο σχέδιο λεπτομερειών
- αφού γίνουν οι ηλεκτρικές συνδέσεις, τοποθετήστε σωστά το βύσμα στο αντίστοιχο βύσμα.

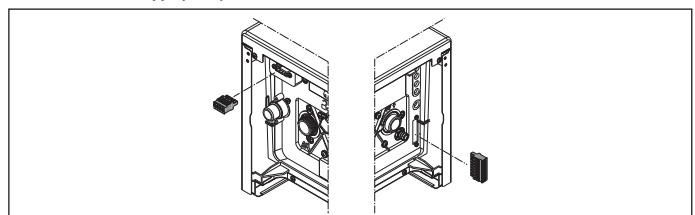

⚠ Συνιστάται η χρήση αγωγών με διατομές σύρματος από τουλάχιστον 0,35 mm² έως μέγιστο 1,5 mm². Για τη σύνδεση του BUS 485, συνιστάται η χρήση του θωρακισμένου καλωδίου εάν το σήμα περνά κοντά σε άλλους ηλεκτρικούς αγωγούς ή αγωγούς τάσης δικτύου (230V).

⚠ Σε περίπτωση σύνδεσης TA ή TBT, αφαιρέστε τους αντίστοιχους βραχυκυκλωτήρες που βρίσκονται στο κιβώτιο ακροδεκτών.

ΣΗΜΕΙΩΣΗ: σε περίπτωση σύνδεσης τηλεχειριστήριου OT+ στο σύστημα, εάν η παράμετρος P803=1 (SERVICE), η οθόνη του λέβητα εμφανίζει την ακόλουθη ένδειξη:



Σημείωση: Δεν διασφαλίζεται η πλήρης συμβατότητα με συσκευές OpenTherm τρίτων κατασκευαστών.

Πρέπει επίσης να σημειωθεί ότι, εάν το τηλεχειριστήριο OT+ είναι συνδεδεμένο:

- δεν είναι πλέον δυνατή η ρύθμιση της κατάστασης του λέβητα OFF/ΧΕΙΜΩΝΑΣ/ΚΑΛΟΚΑΙΡΙ (ρυθμίζεται από το τηλεχειριστήριο OT+)
- δεν είναι πλέον δυνατή η ρύθμιση της τιμής του σημείου ρύθμισης του ζεστού νερού χρήσης (ρυθμίζεται από το τηλεχειριστήριο OT+)
- ο συνδυασμός κουμπιών **A+B** παραμένει ενεργός για τη ρύθμιση της λειτουργίας ΑΝΕΣΗ
- η τιμή του σημείου ρύθμισης του ζεστού νερού χρήσης (I005) εμφανίζεται στο μενού INFO
- η τιμή του σημείου ρύθμισης της θέρμανσης που υπολογίζεται από το τηλεχειριστήριο OT+ (I017) εμφανίζεται στο μενού INFO
- είναι δυνατή η ρύθμιση του σημείου ρύθμισης θέρμανσης στον λέβητα μόνο εάν P311=1 ή P311 = 0 και ο «βραχυκυκλωτήρας» είναι κλειστός. Μπορείτε να συμβουλευτείτε την τιμή στο μενού INFO (I016)
- για να ενεργοποιήσετε τη λειτουργία ΑΝΑΛΥΣΗ ΚΑΥΣΗΣ με συνδεδεμένο το τηλεχειριστήριο OT+, είναι απαραίτητο να απενεργοποιήσετε προσωρινά τη σύνδεση ρυθμίζοντας την παράμετρο P803 = 0 (SERVICE), θυμηθείτε να επαναφέρετε την τιμή αυτής της παραμέτρου μόλις ολοκληρωθεί η λειτουργία.

Το κουμπί 2 παραμένει ενεργό για τον μηδενισμό του συναγερμού.

Το κουμπί 3 παραμένει ενεργό για την εμφάνιση του μενού INFO και την ενεργοποίηση του μενού ΡΥΘΜΙΣΕΙΣ.

Συνδέσεις υψηλής τάσης

Η σύνδεση με το ηλεκτρικό δίκτυο πρέπει να γίνεται μέσω μιας διάταξης διαχωρισμού με πολυπολικό άνοιγμα επαφών τουλάχιστον 3,5 mm (EN 60335/1, κατηγορία 3). Η συσκευή λειτουργεί με εναλλασσόμενο ρεύμα 230 Volt/50 Hz και συμμορφώνεται με το πρότυπο EN 60335-1. Είναι υποχρεωτική η σύνδεση με γείωση σύμφωνα με τον ισχύοντα κανονισμό.

⚠ Αποτελεί ευθύνη του υπεύθυνου εγκατάστασης να διασφαλίσει επαρκή γείωση της συσκευής. Ο κατασκευαστής δεν ευθύνεται για τυχόν ζημιές που προκαλούνται από λανθασμένη εγκατάσταση ή έλλειψη γείωσης.

⚠ Συνιστάται να τηρείτε τη σύνδεση ουδέτερης φάσης (L-N).

⚠ Ο αγωγός γείωσης θα πρέπει να βρίσκεται λίγα εκατοστά μακρύτερος από τους άλλους.

⚠ Για να διασφαλίσετε τη στεγανότητα του λέβητα, χρησιμοποιήστε έναν σφιγκτήρα και σφίξτε τον στον χρησιμοποιούμενο δακτύλιο στερέωσης.

Ο λέβητας μπορεί να λειτουργήσει με τροφοδοσία φάση-ουδέτερο ή φάση-φάση. Απαγορεύεται η χρήση σωλήνων αερίου και/ή νερού σαν γείωση ηλεκτρικών συσκευών. Για την ηλεκτρική σύνδεση να χρησιμοποιείτε το παρεχόμενο καλώδιο τροφοδοσίας. Σε περίπτωση αντικατάστασης του καλωδίου τροφοδοσίας, χρησιμοποιήστε καλώδιο τύπου HAR H05V2V2-F, 3x 0,75 mm², Ø με μεγ. εξωτερική διάμετρο 7 mm.

4.7 Σύνδεση αερίου

Η σύνδεση του αερίου πρέπει να πραγματοποιείται σύμφωνα με τα ισχύοντα πρότυπα εγκατάστασης. Πριν από τη σύνδεση:

- βεβαιωθείτε ότι το αέριο που διανέμεται αντιστοιχεί σε αυτό για το οποίο έχει προετοιμαστεί ο λέβητας (βλέπε πινακίδα χαρακτηριστικών).

4.8 Αφαίρεση του περιβλήματος

Για να αποκτήσετε πρόσβαση στα εσωτερικά εξαρτήματα, αφαιρέστε το περίβλημα όπως φαίνεται στην εικόνα.

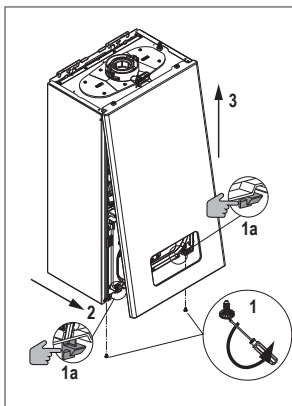

⚠ Για να σφίξετε τις βίδες, εφαρμόστε ροπή 0,6 - 0,8 Nm

⚠ Σε περίπτωση που τα πλευρικά τοιχώματα έχουν αφαιρεθεί, συναρμολογήστε τα στην αρχική τους θέση, ανατρέχοντας στην αυτοκόλλητη ετικέτα που βρίσκεται στον τοίχο.

⚠ Εάν το εμπρόσθιο τοίχωμα έχει υποστεί ζημιά, πρέπει να αντικατασταθεί.

⚠ Τα ηχομονωτικά τοιχώματα στο εσωτερικό του εμπρόσθιου και των πλευρικών τοιχωμάτων έχουν σχεδιαστεί έτσι ώστε να διασφαλίζουν ότι το κύκλωμα προσαγωγής αέρα είναι σφραγισμένο από το περιβάλλον της εγκατάστασης.

⚠ ΕΙΝΑΙ επομένως ΑΠΑΡΑΙΤΗΤΟ μετά τις εργασίες αποσυναρμολόγησης να επανατοποθετηθούν σωστά τα εξαρτήματα, ώστε να εξασφαλιστεί η στεγανότητα του λέβητα.

4.9 Εκκένωση καπνών και αναρρόφηση αέρα καύσης

Για την εκκένωση των προϊόντων καύσης ανατρέξτε στο πρότυπο UNI7129-7131. Επίσης, θα πρέπει πάντοτε να τηρείτε τους τοπικούς κανονισμούς της Πυροσβεστικής, της Εταιρείας Αερίου και άλλες κοινοτικές διατάξεις. Για την εξαγωγή των καπνών και την επαγωγή του αέρα καύσης του λέβητα θα πρέπει να χρησιμοποιείτε μόνο πιστοποιημένες αυθεντικές σωληνώσεις (εκτός του τύπου C6 ακόμα κι αν είναι πιστοποιημένες) και η σύνδεση να γίνεται με σωστό τρόπο όπως υποδεικνύεται στις οδηγίες που παρέχονται μαζί με τα αξεσουάρ καπνών. Σε μια και μόνο καμινάδα μπορείτε να συνδέσετε περισσότερες συσκευές με την προϋπόθεση ότι όλες είναι τύπου συμπίκνωσης.

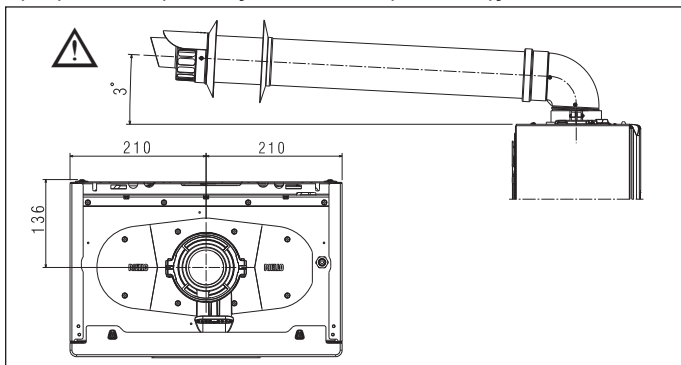

⚠ Ο πύργος απαγωγής καυσαερίων του λέβητα είναι διαστασιοποιημένος για ομόκεντρο αγωγό με εξωτερική διάμετρο σωλήνα καυσαερίων 60 +0,6 -0,3 mm και εξωτερική διάμετρο σωλήνα αέρα 100 +0,3 -0,7 mm. Βεβαιωθείτε ότι η σύνδεση είναι αεροστεγής.

⚠ Μην εγκαθιστάτε τους αγωγούς εκκένωσης καπνού κοντά σε εύπλαστα ή πλαστικά υλικά, τα χαρακτηριστικά των οποίων μπορούν να μεταβληθούν σε υψηλές θερμοκρασίες.

⚠ Το ευθύγραμμο μήκος νοείται χωρίς καμπύλες, συμπεριλαμβανομένων των ακροδεκτών και των συνδέσεων.

⚠ Ο λέβητας παρέχεται χωρίς το σετ εκκένωσης καπνών/αναρρόφησης αέρα, εφόσον μπορείτε να χρησιμοποιήσετε τα αξεσουάρ για συσκευές συμπίκνωσης που προσαρμόζονται καλύτερα στα τυπολογικά χαρακτηριστικά (βλ. κατάλογο).

⚠ Εάν χρησιμοποιηθούν μη αυθεντικοί αγωγοί εκκένωσης καπνών/αναρρόφησης αέρα, πρέπει να διασφαλίζεται ότι οι αγωγοί που χρησιμοποιούνται είναι πιστοποιημένοι και συμμορφώνονται με τη συσκευή στην οποία συνδέονται, έχουν κατηγορία θερμοκρασίας $\geq 120^{\circ}\text{C}$ και είναι ανθεκτικοί στη συμπίκνωση.

⚠ Για να εξασφαλίσετε μια ασφαλέστερη εγκατάσταση, στερεώστε τους αγωγούς στον τοίχο (τοίχο ή οροφή) χρησιμοποιώντας ειδικά λαμάκια στερέωσης που πρέπει να τοποθετούνται σε κάθε σύνδεση, σε απόσταση που δεν υπερβαίνει το μήκος κάθε επέκτασης και αμέσως πριν και μετά από κάθε αλλαγή κατεύθυνσης (καμπύλη).

⚠ Τα μέγιστα μήκη των αγωγών αναφέρονται στις καπνοδόχους που διτίθενται στον κατάλογο.

⚠ Είναι υποχρεωτική η χρήση ειδικών αγωγών.

⚠ Οι τοίχοι που είναι ευαίσθητοι στη ζέση (π.χ. οι ξύλινοι) θα πρέπει να προστατεύονται με κατάλληλη μόνωση.

⚠ Οι μη μονωμένοι αγωγοί εκκένωσης είναι δύναμι πηγές κινδύνου.

⚠ Η χρήση ενός αγωγού με μεγαλύτερο μήκος προκαλεί απώλεια ισχύος του λέβητα.

⚠ Οι αγωγοί εκκένωσης μπορούν να είναι γυρισμένοι προς την καταλληλότερη κατεύθυνση ανάλογα με τις ανάγκες εγκατάστασης.

⚠ Όπως απαιτείται από τους ισχύοντες κανονισμούς, ο λέβητας είναι κατάλληλος για τη λήψη και τη διάθεση συμπυκνωμάτων καπνών και/ή όμβριων υδάτων από το σύστημα εκκένωσης καπνών.

⚠ Εάν έχει εγκατασταθεί αντλία ώθησης συμπυκνωμάτων, ελέγξτε τα τεχνικά στοιχεία σχετικά με την παροχή που παρέχει ο κατασκευαστής για να διασφαλίσετε τη σωστή λειτουργία της.

- Τοποθετήστε τον αγωγό εκκένωσης έτσι ώστε η σύνδεση να εισέρχεται πλήρως στον πύργο καυσαερίων του λέβητα.
- Αφού τοποθετηθεί, βεβαιωθείτε ότι οι 4 εγκοπές (A) εισέρχονται στην ειδική αυλάκωση (B).
- Σφίξτε εντελώς τις βίδες (C) που σφίγγουν τους δύο σφιγκτήρες στη φλάντζα, έτσι ώστε η κάμψη να στερεωθεί στη φλάντζα.

Για τα μήκη των αγωγών εκκένωσης, ανατρέξτε στο κεφάλαιο «Πίνακες διαμορφώσεων των αγωγών εκκένωσης καπνού» στις σελίδες 81-82.

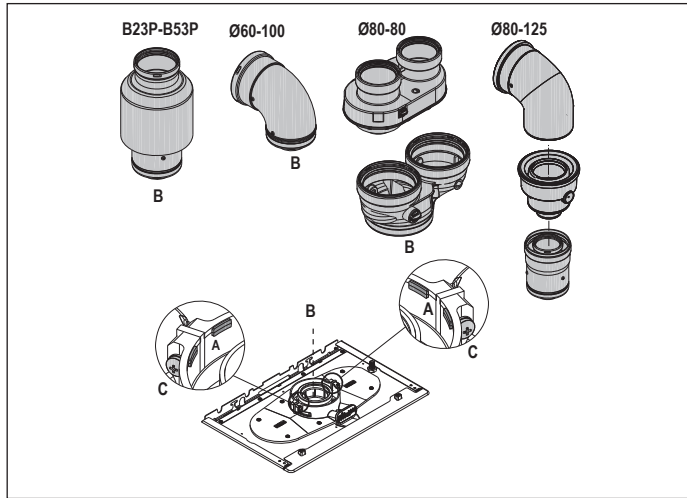

Σύστημα διπλών σωλήνων καυσαερίων με τη χρήση του kit σύνδεσης sistemulvi σύστημα διπλών σωλήνων καυσαερίων Ø80 (αξεσουάρ)

⚠ Οι συνδέσεις του kit σύνδεσης για διαχωρισμένο σύστημα Ø 80 είναι διαστασιολογημένες για αγωγούς με εξωτερική διάμετρο 80 +0,3 -0,7 mm. Βεβαιωθείτε ότι η σύνδεση είναι αεροστεγής.

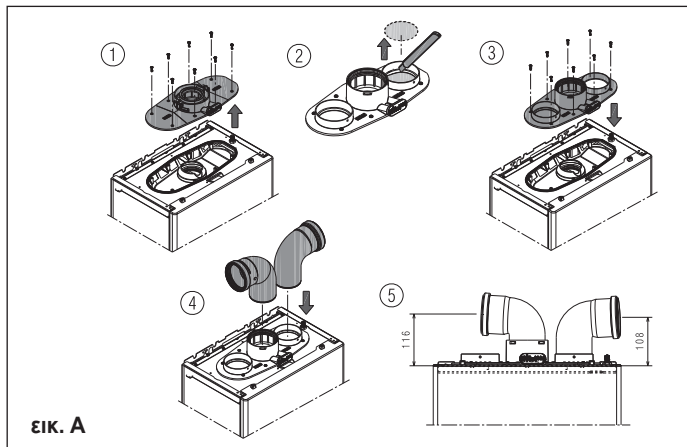

Εάν αντί για το διαχωρισμένο σύστημα χρησιμοποιηθεί το kit διαχωριστή από Ø 60-100 σε Ø 80-80, υπάρχει απώλεια στα μέγιστα μήκη, όπως φαίνεται στον πίνακα.

	Ø 50	Ø 60	Ø 80
Απώλεια μήκους (m)	0,5	1,2	5,5 για αγωγό καπνών 7,5 για αγωγό αέρα

Διαχωρισμένοι αγωγοί Ø 80 με σύνδεση σωλήνων Ø50 - Ø60 - Ø80

Τα χαρακτηριστικά του λέβητα επιτρέπουν τη σύνδεση του αγωγού εκκένωσης καπνού Ø 80 στις συνδέσεις σωλήνων Ø50 - Ø60 - Ø80.

⚠ Για τη σύνδεση συνιστάται να κάνετε έναν υπολογισμό προκειμένου να τηρείται η ισχύουσα νομοθεσία επί του θέματος.

Στον πίνακα αναγράφονται οι διάφορες βασικές επιτρεπόμενες διαμορφώσεις.

Πίνακες βασικών διαμορφώσεων αγωγών (*)

Εισαγωγή αέρα	1 καμπύλη 90° Ø 80 4,5 m σωλήνας Ø 80
Εξαγωγή καπνών	1 καμπύλη 90° Ø 80 4,5 m σωλήνας Ø 80 Μείωση από Ø 80 σε Ø 50 από Ø 80 σε Ø 60 Βασική καμπύλη καμινάδας 90°, Ø 50 ή Ø 60 ή Ø 80 Για τα μήκη του αγωγού σύνδεσης δείτε τον πίνακα

(*) Χρησιμοποιήστε πλαστικούς αγωγούς (PP) κατάλληλους για λέβητες συμπύκνωσης και με κατηγορία πίεσης (P1 έως 200 Pa - H1 έως 5000 Pa) κατάλληλη για την εφαρμογή, με αναφορά στην τιμή DP εξόδου του λέβητα που αναφέρεται στους «Πίνακες κανονισμών».

Οι λέβητες όταν βγαίνουν από το εργοστάσιο είναι ρυθμισμένοι ως εξής:

		στροφές/ λεπτό Θέρμανση		μέγιστο μήκος αγωγών (m)		
		Θέρμ.	ZNX	Ø50	Ø60	Ø80
25 HM BIS		6.300	7.900	7	23	116
				6	20	98
35 HM BIS		7.400	8.600	2	12	62
				1	11	57

Αν είναι απαραίτητο να επιτευχθούν μεγαλύτερα μήκη, αντισταθμίστε τις απώλειες φορτίου με την αύξηση του αριθμού στροφών του ανεμιστήρα, όπως αναφέρεται στον πίνακα ρυθμίσεων προκειμένου να εξασφαλίσετε την θερμική απόδοση που αναγράφεται στην ετικέτα.

⚠ Η ρύθμιση της ελάχιστης απόδοσης δεν πρέπει να τροποποιείται.

Πίνακες ρυθμίσεων

διαχωριστής						
	Περιστροφές ανεμιστήρα rpm		Αγωγοί Ø 50	Αγωγοί Ø 60	Αγωγοί Ø 80	ΔΡ εξόδου λέβητα (Pa)
	Θέρμ.	ZNX	μέγιστο μήκος (m)			
	25 HM BIS	6.300	7.900	7	23	
6.400		8.000	9*	29*	144*	210*
6.500		8.100	11*	34*	172*	257*
6.600		8.200	14*	40*	201*	285*
6.700		8.300	16*	46*	229*	330*
6.800		8.400	18*	51*	257*	355*
6.900		8.500	21*	57*	285*	385*
7.000		8.600	23*	63*	314*	425*
7.100		8.700	25*	68*	342*	465*
7.200		8.800	28*	74*	370*	497*
35 HM BIS	7.400	8.600	2	12	62	195
	7.500	8.700	4*	18*	92*	242*
	7.600	8.800	6*	24*	119*	289*
	7.700	8.900	9*	29*	145*	337*
	7.800	9.000	11*	34*	172*	384*

(*) Μέγιστο μήκος εγκατάστασης ΜΟΝΟ με σωλήνες εξάτμισης κατηγορίας H1.

συμπαγής διαχωριστής						
	Περιστροφές ανεμιστήρα rpm		Αγωγοί Ø 50	Αγωγοί Ø 60	Αγωγοί Ø 80	ΔΡ εξόδου λέβητα (Pa)
	Θέρμ.	ZNX	μέγιστο μήκος (m)			
	25 HM BIS	6.300	7.900	6	20	
6.400		8.000	8*	25*	124*	203*
6.500		8.100	10*	30*	150*	235*
6.600		8.200	13*	35*	176*	268*
6.700		8.300	15*	40*	202*	300*
6.800		8.400	17*	46*	228*	333*
6.900		8.500	19*	51*	253*	365*
7.000		8.600	21*	56*	279*	398*
7.100		8.700	23*	61*	305*	430*
7.200		8.800	25*	66*	331*	463*
35 HM BIS	7.400	8.600	1	11	57	180
	7.500	8.700	3*	17*	84*	227*
	7.600	8.800	6*	22*	111*	274*
	7.700	8.900	8*	28*	138*	322*
	7.800	9.000	10*	33*	165*	369*

(*) Μέγιστο μήκος εγκατάστασης ΜΟΝΟ με σωλήνες εξάτμισης κατηγορίας H1.

Οι διαμορφώσεις Ø50 ή Ø60 ή Ø80 αναφέρουν πειραματικά δεδομένα που έχουν επαληθευτεί στο εργαστήριο.

Σε περίπτωση διαφορετικών εγκαταστάσεων από αυτές που υποδεικνύονται στους πίνακες «βασικές διαμορφώσεις» και «ρυθμίσεις», ανατρέξτε στα ισοδύναμα γραμμικά μήκη που αναφέρονται παρακάτω.

⚠ Σε κάθε περίπτωση εξασφαλίζονται τα μέγιστα μήκη που δηλώνονται στο βιβλιαράκι και είναι πολύ σημαντικό να μην υπερβαίνονται.

ΕΞΑΡΤΗΜΑ	Ισοδύναμο γραμμικό σε μέτρα Ø80 (m)	
	Ø 50	Ø 60
Καμπύλη 45°	12,3	5
Καμπύλη 90°	19,6	8
Προέκταση 0,5m	6,1	2,5
Προέκταση 1,0m	13,5	5,5
Προέκταση 2,0m	29,5	12

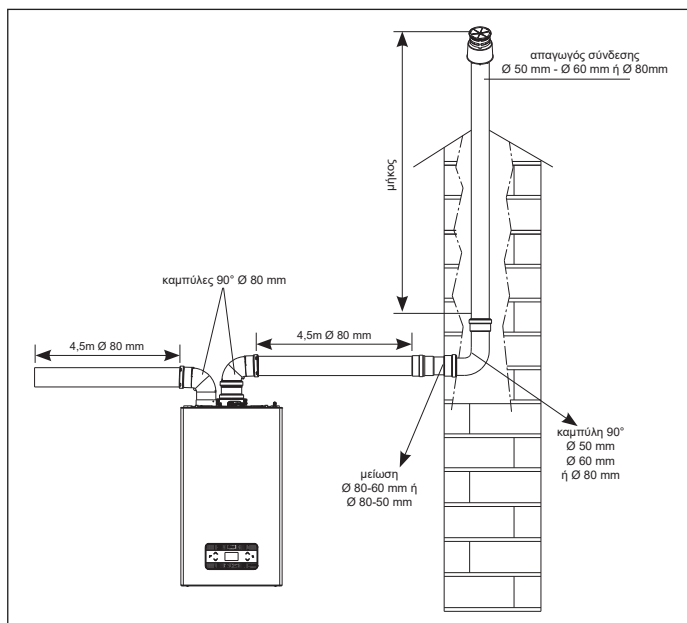

4.10 Εγκατάσταση σε κοινές καπνοδόχους με θετική πίεση

Η κοινή καπνοδόχος είναι ένα σύστημα εκκένωσης καπνού κατάλληλο για τη συλλογή και την αποβολή των προϊόντων καύσης περισσότερων συσκευών που είναι εγκατεστημένες σε περισσότερους ορόφους των κτιρίων. Οι κοινές καπνοδόχους με θετική πίεση μπορούν να χρησιμοποιηθούν μόνο από συσκευές συμπίκνωσης τύπου C. Κατά συνέπεια απαγορεύεται η διαμόρφωση B53P/B23P. Η εγκατάσταση λεβητιών σε κοινές καπνοδόχους με πίεση επιτρέπεται αποκλειστικά **για φυσικό αέριο μεθάνιο**. Η διαστασιολόγηση του λέβητα επιτρέπει τη σωστή λειτουργία έως το σημείο όπου η μέγιστη εσωτερική πίεση της καπνοδόχου δεν υπερβαίνει την τιμή των 25 Pa. Ελέγξτε ότι ο αριθμός στροφών του ανεμιστήρα είναι σύμφωνος με τον πίνακα «τεχνικά στοιχεία».

Βεβαιωθείτε ότι οι αγωγοί αναρρόφησης αέρα και εξαγωγής των προϊόντων καύσης είναι στεγανοί.

Η εγκατάσταση σε συλλογικούς καπνοδόχους υπό πίεση είναι δυνατή μόνο με τη χρήση του kit αξεσουάρ clarpet με ενσωματωμένο σιφόνι, που θα εγκατασταθεί αμέσως στην έξοδο του σωλήνα εκκένωσης καυσαερίων (kit Ø80) ή του σωλήνα εκκένωσης/αναρρόφησης καυσαερίων (kit Ø80/125).

ΣΗΜΕΙΩΣΗ: Η χρήση του kit clarpet Ø80 απαιτεί τη χρήση του kit σύνδεσης διπλού συστήματος Ø80 (εικ. A - 2, σελίδα 58).

Τα kit αξεσουάρ clarpet με ενσωματωμένο σιφόνι που διατίθενται στον κατάλογο είναι κατάλληλα για τη συλλογή και τη ροή του συμπυκνώματος στο εσωτερικό του λέβητα.

ΠΡΟΕΙΔΟΠΟΙΗΣΕΙΣ:

- ⚠️ Οι συσκευές που συνδέονται σε μια κοινή καπνοδόχο πρέπει όλες να είναι ίδιου τύπου και να έχουν ισοδύναμο χαρακτηριστικά καύσης.
- ⚠️ Ο αριθμός συσκευών που μπορούν να συνδεθούν σε μια κοινή καπνοδόχο υπό θετική πίεση προσδιορίζεται από το σχεδιαστή της καπνοδόχου.

Ο λέβητας έχει σχεδιαστεί για να συνδέεται σε κοινή καπνοδόχο που έχει διαστασιολογηθεί για να λειτουργεί υπό συνθήκες όπου η στατική πίεση του κοινού αγωγού μπορεί να υπερβαίνει τη στατική πίεση του κοινού αγωγού αέρα κατά 25 Pa στην περίπτωση όπου n-1 λέβητες λειτουργούν με τη μέγιστη ονομαστική θερμική παροχή και 1 λέβητας λειτουργεί με την ελάχιστη θερμική παροχή που επιτρέπουν οι έλεγχοι.

- ⚠️ Η ελάχιστη επιτρεπόμενη διαφορά πίεσης μεταξύ της εξόδου των καπνών και της εισόδου του αέρα καύσης είναι -200 Pa (συμπεριλαμβανομένης της πίεσης ανέμου - 100 Pa).

Για αυτόν τον τύπο εκκένωσης διατίθενται πρόσθετα εξαρτήματα (γωνίες, προεκτάσεις, ακροδέκτες κ.λπ.), τα οποία καθιστούν δυνατές τις διαμορφώσεις των αγωγών εκκένωσης καπνού που καθορίζονται στο κεφάλαιο «4.8 Εκκένωση καπνών και αναρρόφηση αέρα καύσης»

- ⚠️ Η τοποθέτηση της βαλβίδας αντεπιστροφής (kit clarpet), που διατίθεται στον κατάλογο, είναι υποχρεωτική.

- ⚠️ Οι αγωγοί πρέπει να εγκαθίστανται με τέτοιο τρόπο ώστε να αποφεύγονται εστίες συμπυκνώματος που θα εμπόδιζαν τη σωστή εκκένωση των προϊόντων καύσης.

- ⚠️ Στο σημείο σύνδεσης με την κοινή καπνοδόχο πρέπει να υπάρχει πινακίδα χαρακτηριστικών. Η πινακίδα πρέπει να περιέχει τουλάχιστον τις ακόλουθες πληροφορίες:

- η κοινή καπνοδόχος έχει διαστασιολογηθεί για λέβητες τύπου C(10)3
- τη μέγιστη επιτρεπόμενη παροχή μάζας προϊόντων καύσης σε kg/h
- τις διαστάσεις της σύνδεσης με κοινούς αγωγούς
- ειδοποίηση σχετικά με τα ανοίγματα εξόδου αέρα και εισόδου προϊόντων καύσης της κοινής καπνοδόχου με πίεση, αυτά τα ανοίγματα πρέπει να κλείνουν και να ελέγχεται η στεγανότητά τους όταν αποσυνδέεται ο λέβητας

- το όνομα του κατασκευαστή της κοινής καπνοδόχου ή το αναγνωριστικό του σύμβολο

- ⚠️ Ανατρέξτε στα ισχύοντα πρότυπα για την εξάμιση των προϊόντων καύσης και στις τοπικές ρυθμίσεις.

- ⚠️ Ο αγωγός καπνού πρέπει να επιλεγεί σωστά σύμφωνα με τις παρακάτω παραμέτρους.

	μέγιστο μήκος	ελάχιστο μήκος	MM
Ø 80-80	4,5 + 4,5	0,5	m
Ø 80/125	4,5	0,5	m

- ⚠️ Πριν από οποιαδήποτε ενέργεια, διακόψτε την ηλεκτρική τροφοδοσία της συσκευής.

- ⚠️ Πριν από τη συναρμολόγηση, λιπάνετε τις τσιμούχες με μη διαβρωτικό ολισθητικό.

- ⚠️ Ο αγωγός καπνού πρέπει να έχει κλίση, σε περίπτωση οριζόντιου αγωγού, κατά 3° προς τον λέβητα.

- ⚠️ Ο αριθμός και τα χαρακτηριστικά των συσκευών που συνδέονται στην καπνοδόχο πρέπει να προσαρμόζονται στα πραγματικά χαρακτηριστικά της καπνοδόχου.

- ⚠️ Ο ακροδέκτης του κοινού αγωγού πρέπει να δημιουργεί ελκυσμό.

- ⚠️ Το συμπύκνωμα μπορεί να ρέει στο εσωτερικό του λέβητα.

- ⚠️ Η μέγιστη επιτρεπόμενη τιμή ανακυκλοφορίας σε συνθήκες ανέμου είναι 10%.

- ⚠️ Η μέγιστη επιτρεπόμενη διαφορά πίεσης (25 Pa) μεταξύ της εισόδου των προϊόντων καύσης και της εξόδου του αέρα μιας κοινής καπνοδόχου δεν επιτρέπεται να υπερβεί, όταν n-1 λέβητες λειτουργούν με τη μέγιστη ονομαστική θερμική παροχή και 1 λέβητας με την ελάχιστη θερμική παροχή που επιτρέπουν οι έλεγχοι.

- ⚠️ Ο κοινός αγωγός καπνού πρέπει να είναι κατάλληλος για υπερπίεση τουλάχιστον 200 Pa.

- ⚠️ Η κοινή καπνοδόχος δεν πρέπει να διαθέτει συσκευή εκτροπής ελκυσμού - αντανεμική συσκευή.

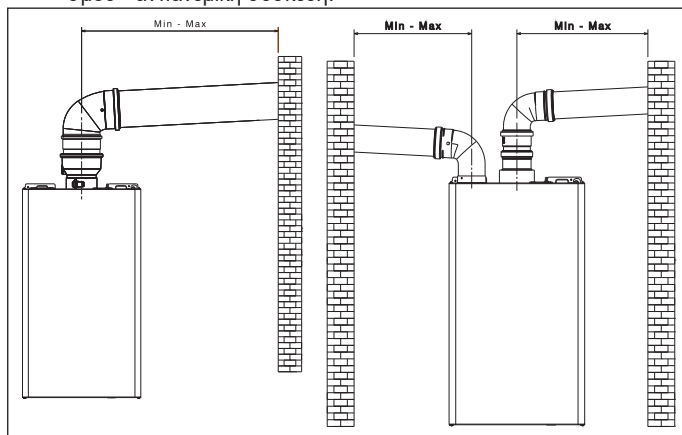

Είναι δυνατή η εγκατάσταση καμπύλων και προεκτάσεων, οι οποίες διατίθενται ως αξεσουάρ με βάση τον επιθυμητό τύπο εγκατάστασης. Τα μέγιστα επιτρεπόμενα μήκη του αγωγού καπνού και του αγωγού αναρρόφησης αέρα παρατίθενται στο κεφάλαιο «4.8 Εκκένωση καπνών και αναρρόφηση αέρα καύσης».

Με την εγκατάσταση C(10)3 ο αριθμός στροφών του ανεμιστήρα (στροφές ανά λεπτό) πρέπει σε κάθε περίπτωση να αναγράφεται στην ετικέτα στην πλευρά του σειριακού αριθμού του προϊόντος.

4.11 Πλήρωση της εγκατάστασης θέρμανσης και εξαέρωση

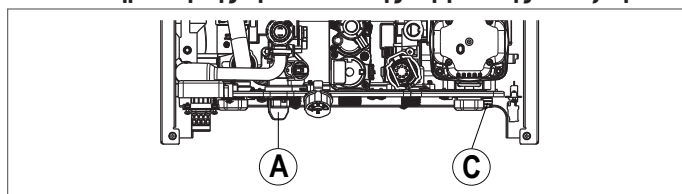

ΣΗΜΕΙΩΣΗ: οι εργασίες πλήρωσης του συστήματος πρέπει να γίνονται με τη χρήση της βάνας πλήρωσης (A) και να βεβαιωθείτε ότι ο λέβητας τροφοδοτείται ηλεκτρικά.

ΣΗΜΕΙΩΣΗ: κάθε φορά που ο λέβητας τροφοδοτείται ηλεκτρικά, εκτελείται ο αυτόματος κύκλος εξαέρωσης.

ΣΗΜΕΙΩΣΗ: η παρουσία συναγερμού νερού (E040, E041 ή E042) δεν επιτρέπει την εκτέλεση του κύκλου εξαέρωσης.

Προχωρήστε στην πλήρωση του συστήματος θέρμανσης εκτελώντας τα ακόλουθα βήματα:

- ανοίξτε τη βάνα πλήρωσης (A) περιστρέφοντάς την αριστερόστροφα
- ελέγξτε ότι η τιμή της πίεσης φτάνει τα 1-1,5 bar με τη βοήθεια ενός υδρόμετρου που τοποθετείται κάτω από το υποστηρίγμα
- κλείστε τη βάνα πλήρωσης (A).

ΣΗΜΕΙΩΣΗ: εάν η πίεση του δικτύου είναι μικρότερη από 1 bar, κρατήστε τη βάνα πλήρωσης ανοικτή (A) κατά τη διάρκεια του κύκλου εξαέρωσης και κλείστε τη μόλις αυτός ολοκληρωθεί.

Για την **έναρξη** του κύκλου εξαερισμού:

- αποσυνδέστε την παροχή ρεύματος για μερικά δευτερόλεπτα
- επαναφέρετε την παροχή ρεύματος αφήνοντας τον λέβητα σε κατάσταση OFF
- βεβαιωθείτε ότι η βάνα αερίου είναι κλειστή.

Στο **τέλος** του κύκλου, εάν η πίεση του κυκλώματος έχει μειωθεί, γυρίστε ξανά τη βάνα πλήρωσης (A) για να επανέλθει η πίεση στη συνιστώμενη τιμή (1-1,5 bar).

Μετά τον κύκλο εξαέρωσης ο λέβητας είναι έτοιμος.

- Αφαιρέστε τυχόν αέρα από την οικιακή εγκατάσταση (θερμαντικά σώματα, συλλέκτες ζωνών κ.λπ.) μέσω των σχετικών βαλβίδων απαέρωσης.
- Βεβαιωθείτε ξανά ότι υπάρχει η σωστή πίεση στην εγκατάσταση (ιδανική 1- 1,5 bar) και επαναφέρετε την, εάν είναι απαραίτητο.
- Εάν εξακολουθεί να υπάρχει αέρας κατά τη διάρκεια της λειτουργίας, ο κύκλος εξαέρωσης πρέπει να επαναληφθεί.
- Ολοκληρώστε τις εργασίες, ανοίξτε τη βάνα αερίου και προχωρήστε σε έναυση του λέβητα.

Σε αυτό το σημείο, μπορεί να υποβληθεί οποιοδήποτε αίτημα για θέρμανση.

4.12 Άδειασμα του κυκλώματος θέρμανσης του λέβητα

Πριν ξεκινήσετε το άδειασμα, θέστε τον λέβητα σε κατάσταση OFF και αποσυνδέστε την ηλεκτρική τροφοδοσία θέτοντας τον κεντρικό διακόπτη της εγκατάστασης στη θέση «αβηστό».

- Κλείστε τις βάνες της εγκατάστασης θέρμανσης (εάν υπάρχει).
- Συνδέστε έναν σωλήνα στη βάνα εκκένωσης της εγκατάστασης (C) και, στη συνέχεια, περιστρέψτε την αριστερόστροφα με το χέρι για να αποστραγγίσετε το νερό.
- ΣΗΜΕΙΩΣΗ: ενεργοποιήστε τη βάνα εκκένωσης της εγκατάστασης (C) με κλειδί 13
- Τελειώστε τις εργασίες, αφαιρέστε τον σωλήνα εκκένωσης από τη βάνα εκκένωσης της εγκατάστασης (C) και κλείστε την ξανά.

4.13 Άδειασμα κυκλώματος ζεστού νερού χρήσης λέβητα

Κάθε φορά που υπάρχει κίνδυνος παγώματος, θα πρέπει να αδειάζετε την εγκατάσταση ζεστού νερού οικιακής χρήσης με τον ακόλουθο τρόπο:

- κλείστε τη γενική βάνα του δικτύου υδροδότησης
- ανοίξτε όλες τις βάνες κρύου και ζεστού νερού
- αδειάστε τα πιο χαμηλά σημεία.

5 ΘΕΣΗ ΣΕ ΛΕΙΤΟΥΡΓΙΑ

5.1 Προκαταρκτικοί έλεγχοι

Η πρώτη ενεργοποίηση πραγματοποιείται από αρμόδιο προσωπικό της Υπηρεσίας Τεχνικής Εξυπηρέτησης. Πριν ενεργοποιήσετε τον λέβητα, βεβαιωθείτε για τα εξής:

- ότι τα στοιχεία των δικτύων τροφοδοσίας (ηλεκτρικό, υδροδότηση, αέριο) αντιστοιχούν σε αυτά της πινακίδας
- ότι οι αγωγοί εκκένωσης καπνού και αναρρόφησης αέρα συμμορφώνονται με τους ισχύοντες κανονισμούς και τηρούν τα μέγιστα επιτρεπόμενα μήκη
- ότι εξασφαλίζονται οι κατάλληλες συνθήκες για τις κανονικές συντηρήσεις στην περίπτωση που ο λέβητας είναι κλεισμένος μέσα ή ανάμεσα σε έπιπλα
- τη στεγανότητα της εγκατάστασης προσαγωγής καυσίμου
- ότι η παροχή του καυσίμου αντιστοιχεί στις τιμές που απαιτούνται για τον λέβητα
- ότι η εγκατάσταση τροφοδοσίας του καυσίμου έχει τις κατάλληλες διαστάσεις για την απαραίτητη παροχή στον λέβητα και ότι διαθέτει όλους τους μηχανισμούς ασφαλείας και ελέγχου σύμφωνα με τους ισχύοντες κανόνες
- βεβαιωθείτε ότι ο κυκλοφορητής περιστρέφεται ελεύθερα, δεδομένου ότι μετά από μεγάλες περιόδους μη λειτουργίας, ενδέχεται τυχόν επικαθίσεις ή/και υπολείμματα να εμποδίζουν την ελεύθερη περιστροφή του
- ότι το σιφόνι είναι πλήρως γεμάτο με νερό, διαφορετικά γεμίστε το ξανά (βλ. κεφάλαιο «5.2 Πρώτη θέση σε λειτουργία»).

5.2 Πρώτη θέση σε λειτουργία

Κατά την πρώτη ενεργοποίηση, σε περίπτωση παρατεταμένης μη χρήσης και σε περίπτωση εργασιών συντήρησης, είναι απαραίτητο να προχωρήσετε όπως περιγράφεται στις ακόλουθες παραγράφους πριν θέσετε τη συσκευή σε λειτουργία. Κατά την πρώτη εκκίνηση, συνιστάται επίσης η διαδικασία βαθμονόμησης (GAC) για να επιτρέψει στον λέβητα να φτάσει τη βέλτιστη απόδοσή του. Εάν η διαδικασία δεν εκτελεστεί, για 60 δευτερόλεπτα κάθε 10 λεπτά στην οθόνη εμφανίζεται "CFG" (με P105 = 1 ΚΥΛΙΣΗ --> ΚΛΗΣΗ ΓΙΑ ΓΑΚ):



5.2.1 Πλήρωση σιφονιού συλλέκτη συμπυκνώματος

Προλάβετε την πλήρωση συμπυκνωμάτων ρίχνοντας περίπου 1 λίτρο νερό στην υποδοχή ανάλυσης καύσης του λέβητα και ελέγξτε:

- τη σωστή εκροή νερού από τον σωλήνα εξόδου του λέβητα
- τη στεγανότητα της γραμμής σύνδεσης του αγωγού εκκένωσης συμπυκνώματος.

Η σωστή λειτουργία του κυκλώματος εκκένωσης συμπυκνώματος (σιφόνι και αγωγοί) προϋποθέτει να μην υπερβαίνεται η μέγιστη στάθμη συμπυκνώματος (max).

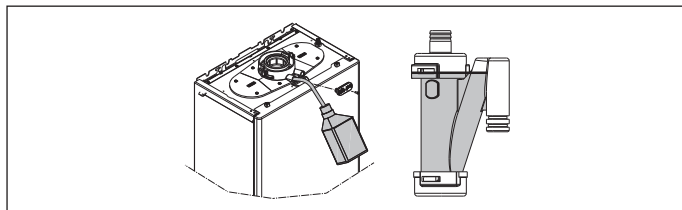

5.3 Κύκλος εξαέρωσης

Τοποθετήστε τον γενικό διακόπτη του συστήματος στη θέση «αναμμένο». Κάθε φορά που ο λέβητας τροφοδοτείται, εκτελείται ένας κύκλος εξαέρωσης διάρκειας 4 λεπτών. Η οθόνη εμφανίζεται ως εξής (με P105 = 1 ΚΥΛΙΣΗ --> ΚΥΚΛΟΣ ΕΞΑΕΡΩΣΗΣ ΣΕ ΕΞΕΛΙΞΗ):

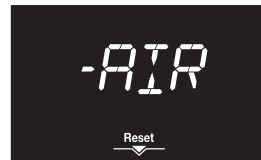

Για να διακόψετε τον κύκλο εξαέρωσης, πατήστε

- ⚠ Όταν εκτελείται ο κύκλος εξαέρωσης, όλες οι αιτήσεις θέρμανσης αναστέλλονται, εκτός από τα αιτήματα ζεστού νερού χρήσης όταν ο λέβητας δεν είναι σε κατάσταση OFF.

Ο κύκλος εξαέρωσης μπορεί επίσης να διακοπεί, εάν ο λέβητας δεν βρίσκεται σε κατάσταση OFF, από ένα αίτημα θέρμανσης ζεστού νερού χρήσης.

5.4 Χειροκίνητη διαδικασία βαθμονόμησης (GAC)

Η διαδικασία GAC, χρήσιμη για τη βαθμονόμηση της βαλβίδας αερίου και του συστήματος ελέγχου της καύσης είναι υποχρεωτική ως εξής: μετατροπή αερίου - αντικατάσταση βαλβίδας αερίου - αντικατάσταση της πλακέτας- αντικατάσταση ανεμιστήρα - καθαρισμός πρωτεύοντος εναλλάκτη και/ή καυστήρα - αντικατάσταση ηλεκτροδίου εντοπισμού φλόγας (ιονισμού) - τροποποίηση αγωγών εισαγωγής/εξαγωγής - καθαρισμός του μεταφορέα, καθαρισμός ανεμιστήρα, καθαρισμός φίλτρου ανεμιστήρα μείκτη, αντικατάσταση του εναλλάκτη, αντικατάσταση του εναλλάκτη και του συγκροτήματος μεταφορέα.

Η διαδικασία GAC πρέπει επίσης να εκτελείται κατά την πρώτη ενεργοποίηση. Εάν η διαδικασία αυτή καθυστερήσει εγκαίρως, ο λέβητας διατηρεί πλήρως την ασφάλειά του, ωστόσο μπορεί να περιοριστεί σε επίπεδο επιδόσεων και μπορεί επίσης να επεξεργάζεται σήματα ελέγχου καύσης.

- ⚠ Η διαδικασία πρέπει να εκτελείται με το περίβλημα κλειστό.

Οποιαδήποτε επανάληψη της GAC που δεν ολοκληρώνεται επιτυχώς αφήνει το σύστημα στην κατάσταση «GAC not completed» (Η διαδικασία GAC δεν ολοκληρώθηκε).

Το σύστημα εναλλάσσει (εκτός από τη σήμανση ΣΥΝΑΓΕΡΜΟΣ, ΠΛΗΡΟΦΟΡΙΕΣ και ΠΡΟΓΡΑΜΜΑΤΙΣΜΟΣ) την κανονική οθόνη με την ένδειξη "CFG" (με P105 = 1 ΚΥΛΙΣΗ --> ΗΚΛΗΣΗ ΓΙΑ ΓΑΚ) υπενθύμιση ότι θα πρέπει να γίνει η GAC και ότι επομένως ο λέβητας μπορεί να έχει περιορισμούς στη λειτουργία του.

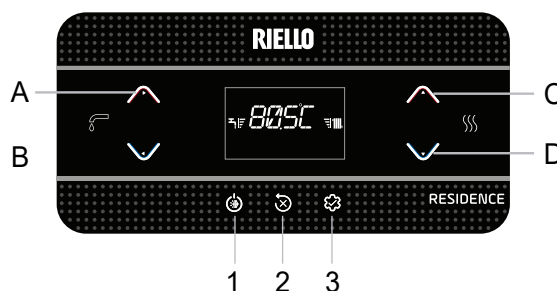

- Ενεργοποιήστε ηλεκτρικά τον λέβητα και περιμένετε να τρέξει ο κύκλος εξαέρωσης (βλέπε παράγραφο «5.3 Κύκλος εξαέρωσης» του εγχειριδίου του υπεύθυνου εγκατάστασης).
- Εάν είναι στην κατάσταση OFF, ρυθμίστε την εποχή ΚΑΛΟΚΑΙΡΙ με το κουμπί 1.
- Δημιουργήστε μια ζήτηση ZNX 5 λίτρων ανά λεπτό ή περισσότερο. Αν και δεν υπάρχουν περιορισμοί από την πλευρά του συστήματος, εκτός από αυτούς που προβλέπονται από την επίβλεψη ALARMS, ωστόσο, συνιστάται η σάρωση GAC να γίνεται με νερό συστήματος επιστροφής λέβητα κάτω από 15°C ή σε κάθε περίπτωση με θερμοκρασία συμβατή με τη ροή ρυθμός του νερού του συστήματος προς το λέβητα.
- Περιμένετε μέχρι να εμφανιστεί στην οθόνη το σύμβολο της φλόγας.

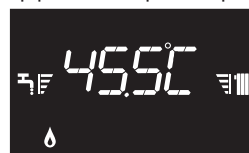

- Αποκτήστε πρόσβαση στις παραμέτρους (βλ. διαδικασία που αναφέρεται στο κεφάλαιο 10 «Ρύθμιση κωδικών πρόσβασης, πρόσβαση και τροποποίηση παραμέτρων»).
- Επιλέξτε το μενού **P2** χρησιμοποιώντας τα πλήκτρα **C** ή **D** και επιβεβαιώστε χρησιμοποιώντας το πλήκτρο **A**.
- Επιλέξτε την παράμετρο P206 χρησιμοποιώντας τα πλήκτρα **C** ή **D** και επιβεβαιώστε χρησιμοποιώντας το πλήκτρο **A**.

Σημείωση: η παράμετρος δεν είναι διαθέσιμη όταν δεν υπάρχει αίτημα θερμότητας.

- Θέστε P206 = 1 το πλήκτρο **C** για να ενεργοποιήσετε τη λειτουργία GAC.



Στην οθόνη αναβοσβήνει η ένδειξη GAC και αρχίζει μια φάση αναμονής περίπου 1 λεπτού, μετά την οποία αρχίζει η βαθμονόμηση. Κατά τη διάρκεια αυτής της φάσης, η ένδειξη «GAC» αναβοσβήνει, εναλλάξ με τον αριθμό στροφών του ανεμιστήρα, για διάρκεια περίπου 2-5 λεπτών.



Σε αυτό το στάδιο, δεν πρέπει να πατηθεί κανένα κουμπί μέχρι να εμφανιστεί η ένδειξη "END" (με P105 = 1 ΚΥΛΙΣΗ --> ΔΙΑΚΟΠΗ ΛΕΙΤΟΥΡΓΙΑΣ ΣΕ ΕΞΕΛΙΞΗ), η οποία υποδεικνύει ότι η διαδικασία έχει ολοκληρωθεί επιτυχώς.



Εάν η διαδικασία GAC δεν συνεχιστεί, και μετά την επιβεβαίωση παραμένει στην οθόνη η τιμή 1 (η διαδικασία δεν εμφανίζει την ένδειξη GAC), είναι πολύ πιθανό το ηλεκτρονικό σύστημα να πραγματοποιεί έλεγχο της καύσης. Σε αυτήν την περίπτωση περιμένετε μερικά λεπτά και βεβαιωθείτε ότι το σύστημα συνεχίζει αυτόματα. Εάν η κατάσταση παραμένει, προχωρήστε ενδεχομένως σε POWER OFF του λέβητα και επανεκκινήστε τη διαδικασία GAC σύμφωνα με τις οδηγίες.

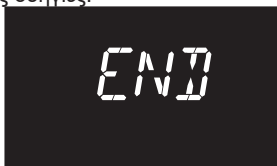

Στο τέλος της συνάρτησης, η παράμετρος επιστρέφει αυτόματα στο 0.



Εάν η διαδικασία GAC δεν ολοκληρωθεί, το σύστημα επιτρέπει την εκτέλεση μιας επανάληψης GAC που εμφανίζεται στην οθόνη με "RTY" και στη συνέχεια συνεχίζει πατώντας το πλήκτρο **B**.



ΣΗΜΕΙΩΣΗ: Εάν δεν είναι δυνατή η διάχυση της θερμότητας στο ζεστό νερό οικιακής χρήσης, είναι ωστόσο δυνατό, για συστήματα υψηλής θερμοκρασίας, να πραγματοποιηθεί η GAC κατόπιν αιτήματος θέρμανσης, ρυθμίζοντας το σημείο ρύθμισης του νερού θέρμανσης στους 80,5°C ή ακόμα καλύτερα, ενεργοποιώντας την ανάλυση καύσης και στη συνέχεια, με αναμμένη φλόγα, ξεκινήστε το GAC. Μόλις ολοκληρωθεί η διαδικασία, πατήστε το πλήκτρο **B** 3 φορές για να επιστρέψετε στην κύρια οθόνη.

Εάν η διαδικασία δεν εκτελεστεί όταν απαιτείται, αυτή η παράλειψη μπορεί να οδηγήσει σε περιορισμένη λειτουργία και σε πιθανή εμφάνιση ανωμαλιών στον έλεγχο καύσης. Εάν παρουσιαστεί σφάλμα κατά τη διάρκεια της διαδικασίας ή εάν διακοπεί το αίτημα θερμότητας, η διαδικασία θα διακοπεί πρόωρα με την εμφάνιση της κατάστασης ανωμαλίας ή με την αυτόματη επιστροφή στην κύρια οθόνη. Σε αυτήν την περίπτωση, η διαδικασία πρέπει να επαναληφθεί.

5.5 Ρύθμιση θερμορύθμισης

Η θερμορύθμιση είναι διαθέσιμη μόνο με συνδεδεμένο εξωτερικό αισθητήρα και είναι ενεργός μόνο για τη λειτουργία ΘΕΡΜΑΝΣΗ.

Η ενεργοποίηση της ΘΕΡΜΟΡΥΘΜΙΣΗΣ πραγματοποιείται ως εξής:

- πρόσβαση στην παράμετρο **P4** → P418 = 1.
- Με P418 = 0 ή αποσυνδεδεμένο εξωτερικό αισθητήρα, ο λέβητας **δουλεύει σε σταθερό σημείο**.
- Η τιμή της θερμοκρασίας που ανιχνεύεται από τον εξωτερικό αισθητήρα

εμφανίζεται στο «6.3 Μενού INFO» στοιχείο I009. Ο αλγόριθμος ελέγχου της θερμοκρασίας δεν θα χρησιμοποιήσει απευθείας τη μετρούμενη τιμή της εξωτερικής θερμοκρασίας, αλλά μια μέση τιμή της εξωτερικής θερμοκρασίας, η οποία λαμβάνει υπόψη τη μόνωση του κτιρίου: σε καλά θερμομονωτικά κτίρια, οι διακυμάνσεις εξωτερικής θερμοκρασίας επηρεάζουν λιγότερο τη θερμοκρασία χώρου σε σχέση με τα λιγότερο θερμομονωτικά. Αυτή η τιμή μπορεί να εμφανιστεί στο μενού INFO στο στοιχείο I010.

ΑΙΤΗΜΑ ΧΡΟΝΟΘΕΡΜΟΣΤΑΤΗ ΟΤ

Σε αυτήν την περίπτωση, το σημείο ρύθμισης της ροής υπολογίζεται από τον χρονοθερμοστάτη σύμφωνα με την τιμή της εξωτερικής θερμοκρασίας και τη διαφορά μεταξύ της θερμοκρασίας του χώρου και της επιθυμητής θερμοκρασίας χώρου.

ΑΙΤΗΜΑ ΘΕΡΜΟΣΤΑΤΗ ΧΩΡΟΥ

Σε αυτήν την περίπτωση, το σημείο ρύθμισης παροχής υπολογίζεται από την πλακέτα ρύθμισης σε συνάρτηση με την τιμή της εξωτερικής θερμοκρασίας, ώστε να ληφθεί μια εκτιμώμενη τιμή θερμοκρασίας χώρου 20° (θερμοκρασία χώρου αναφοράς). Υπάρχουν 2 παράμετροι που εμπλέκονται στον υπολογισμό του σημείου ρύθμισης ροής:

- κλίση της καμπύλης αντιστάθμισης (KT) - μπορεί να τροποποιηθεί από το τεχνικό προσωπικό
- μετατόπιση στη θερμοκρασία χώρου αναφοράς - μπορεί να τροποποιηθεί από τον χρήστη.

ΥΠΟΣΕ ΚΤΙΡΙΟΥ (παράμετρος P433)

ΥΠΟΔΕΙΚΝΥΕΙ τη συχνότητα με την οποία ενημερώνεται η τιμή της εξωτερικής θερμοκρασίας που υπολογίζεται για τη θερμορύθμιση. Για κτίρια με κακή μόνωση, θα χρησιμοποιείται μια χαμηλή τιμή για αυτήν την τιμή.

ΑΝΤΙΔΡΑΣΤΙΚΟΤΗΤΑ SEXT (παράμετρος P434)

ΥΠΟΔΕΙΚΝΥΕΙ την ταχύτητα με την οποία οι μεταβολές της μετρούμενης τιμής της εξωτερικής θερμοκρασίας επηρεάζουν την υπολογιζόμενη τιμή της εξωτερικής θερμοκρασίας για τη θερμορύθμιση, χαμηλές τιμές για την αυτήν την τιμή υποδηλώνουν υψηλές ταχύτητες.

Επιλογή καμπύλης θερμορύθμισης (παράμετρος P419)

Η καμπύλη θερμορύθμισης της θέρμανσης διατηρεί μια θεωρητική θερμοκρασία χώρου 20°C για εξωτερικές θερμοκρασίες μεταξύ +20°C και -20°C. Η επιλογή της καμπύλης εξαρτάται από την ελάχιστη εξωτερική θερμοκρασία σχεδιασμού (και συνεπώς τη γεωγραφική θέση) και τη θερμοκρασία παροχής σχεδιασμού (και συνεπώς τον τύπο του συστήματος) και πρέπει να υπολογίζεται προσεκτικά από τον υπεύθυνο εγκατάστασης, σύμφωνα με τον ακόλουθο τύπο:

$$KT = \frac{\text{Θερμοκρασία παροχής σχεδιασμού} - T_{\text{shift}}}{20 - \text{Ελάχ. εξωτερική θερμοκρασία}}$$

Tshift = 30°C τυπικές εγκαταστάσεις
25°C επιδαπέδιες εγκαταστάσεις

Αν από τον υπολογισμό προκύπτει μια τιμή ανάμεσα σε δύο καμπύλες, συιστάται να επιλέξετε την καμπύλη θερμορύθμισης που πλησιάζει περισσότερο στην τιμή υπολογισμού.

Παράδειγμα: αν η τιμή υπολογισμού είναι 1,3, βρίσκεται ανάμεσα στην καμπύλη 1 και την καμπύλη 1,5. Σε αυτήν την περίπτωση, επιλέξτε την πλησιέστερη καμπύλη, δηλαδή 1,5. Οι τιμές KT που μπορούν να ρυθμιστούν είναι οι ακόλουθες:

- Τυπική εγκατάσταση: 1,0÷3,0
- επιδαπέδια εγκατάσταση 0,2÷ 0,8.

Με την παράμετρο P419 ρυθμίστε την επιλεγμένη καμπύλη θερμορύθμισης:



Μετατόπιση στη θερμοκρασία χώρου αναφοράς

Ωστόσο, ο χρήστης μπορεί να παρέμβει έμμεσα στην τιμή του σημείου ρύθμισης ΘΕΡΜΑΝΣΗΣ, θέτοντας, στην τιμή της θερμοκρασίας αναφοράς (20°C), μια μετατόπιση που μπορεί να κυμαίνεται εντός του εύρους -5÷+5 (μετατόπιση 0 = 20°C). Για τη διόρθωση της μετατόπισης, ανατρέξτε στη διεύθυνση «8.4 Ρύθμιση σημείου ρύθμισης θέρμανσης με εξωτερικό αισθητήρα».

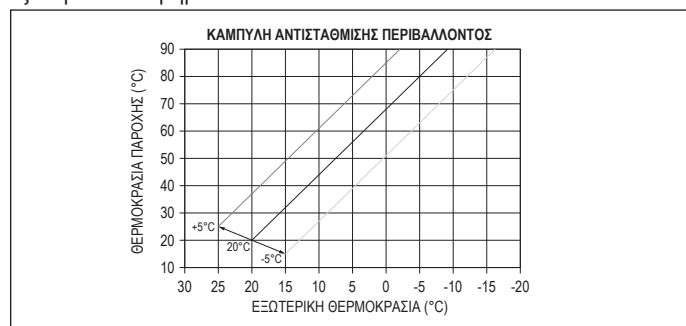

ΝΥΧΤΕΡΙΝΗ ΑΝΤΙΣΤΑΘΜΙΣΗ (παράμετρος P420)

Εάν ένας προγραμματιστής ωραρίου είναι συνδεδεμένος στην είσοδο ΘΕΡΜΟΣΤΑΤΗΣ ΧΩΡΟΥ, από την παράμετρο P420 μπορεί να ενεργοποιηθεί η νυχτερινή αντιστάθμιση.

■ ρύθμιση παραμέτρου P420 = 1.

Σε αυτήν την περίπτωση, όταν η ΕΠΑΦΗ είναι ΚΛΕΙΣΤΗ, το αίτημα για θερμότερα πραγματοποιείται από τον αισθητήρα παροχής, με βάση την εξωτερική θερμοκρασία, προκειμένου να παρέχεται ονομαστική θερμοκρασία χώρου σε επίπεδο ΗΜΕΡΑΣ (20 °C). Το ΑΝΟΙΓΜΑ ΤΗΣ ΕΠΑΦΗΣ δεν προσδιορίζει το σβηστό, αλλά μια μείωση (παράλληλη μετατόπιση) της κλιματικής καμπύλης σε επίπεδο ΝΥΧΤΑΣ (16 °C).

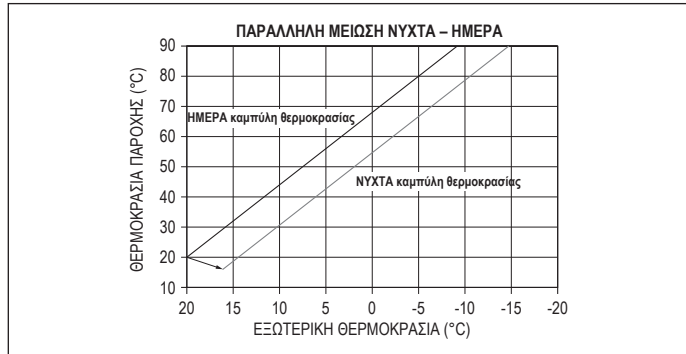

Ο χρήστης μπορεί να παρέμβει έμμεσα στην τιμή του σημείου ρύθμισης ΘΕΡΜΑΝΣΗΣ, εισάγοντας άλλη μία φορά, στην τιμή της θερμοκρασίας αναφοράς ΗΜΕΡΑ (20°C) αντί για ΝΥΧΤΑ (16°C) μια μετατόπιση που μπορεί να κυμαίνεται εντός του εύρους [-5 ÷ +5]. Η ΝΥΧΤΕΡΙΝΗ ΑΝΤΙΣΤΑΘΜΙΣΗ δεν είναι διαθέσιμη εάν είναι συνδεδεμένος ο χρονοδιακόπτης ΟΤ+. Για τη διόρθωση της μετατόπισης, ανατρέξτε στη διεύθυνση «8.3 Ρύθμιση σημείου ρύθμισης θέρμανσης».

5.6 Λειτουργία «Άνεση ζεστού νερού χρήσης»

Ο λέβητας περιλαμβάνει αρχικά ΛΕΙΤΟΥΡΓΙΕΣ "ΑΝΕΣΗ ΖΕΣΤΟΥ ΝΕΡΟΥ ΧΡΗΣΗΣ", οι οποίες, ωστόσο, σε συνδυασμό με ένα DOSSERET, είναι προτιμότερο να μην ενεργοποιούνται καθώς οι ΔΕΞΑΜΕΝΕΣ του DOSSERET εκπληρώνουν αυτούς τους σκοπούς.

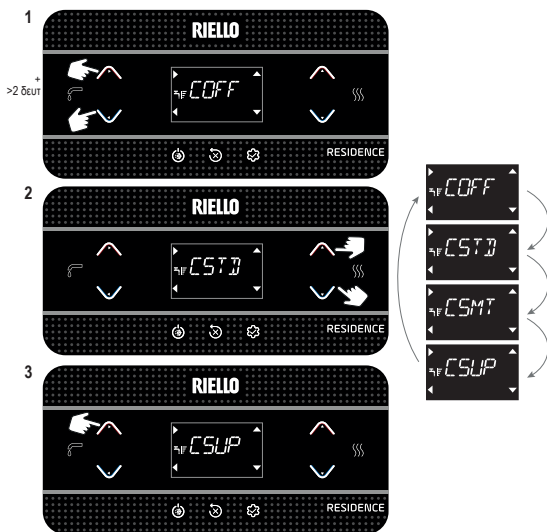

Λειτουργία	Κυλιόμενο μήνυμα
COFF	ΑΝΩΤΕΡΗ ΛΕΙΤΟΥΡΓΙΑ ΑΝΕΣΗΣ
CSTD	ΣΤΑΝΤΑΤΡ ΛΕΙΤΟΥΡΓΙΑ ΑΝΕΣΗΣ
CSMT	ΛΕΙΤΟΥΡΓΙΑ ΑΝΕΣΗΣ ΕΞΥΠΝΗΣ ΛΕΙΤΟΥΡΓΙΑΣ (TOUCH&GO)
CSUP	ΑΝΕΣΗ ΕΞΥΠΝΗΣ ΠΡΟΘΕΡΜΑΝΣΗΣ

CSTD (λειτουργία ΠΡΟΘΕΡΜΑΝΣΗΣ): Ρυθμίζοντας CSTD, ενεργοποιείται η λειτουργία προθέρμανσης ζεστού νερού χρήσης του λέβητα. Η λειτουργία αυτή επιτρέπει τη διατήρηση του ζεστού νερού που περιέχεται στον εναλλάκτη νερού χρήσης προκειμένου να μειωθούν οι χρόνοι αναμονής κατά τις παραλαβές του. Όταν η λειτουργία προθέρμανσης είναι ενεργοποιημένη, εμφανίζεται το PRH στην οθόνη (με P105 = 1 ΚΥΛΙΣΗ --> ΛΕΙΤΟΥΡΓΙΑ ΠΡΟΘΕΡΜΑΝΣΗΣ ΣΕ ΕΞΕΛΙΞΗ). Για να απενεργοποιήσετε τη λειτουργία προθέρμανσης, ρυθμίστε COFF. Η λειτουργία δεν είναι ενεργή όταν ο λέβητας βρίσκεται στη θέση OFF.

CSMT (λειτουργία TOUCH & GO): Εάν δεν θέλετε να αφήνετε τη λειτουργία ΠΡΟΘΕΡΜΑΝΣΗΣ πάντα ενεργοποιημένη και χρειάζεστε ζεστό νερό έτοιμο αμέσως, μπορείτε να προθερμάνετε το ζεστό νερό χρήσης λίγα λεπτά πριν από τη λήψη. Ρυθμίστε το CSMT για να ενεργοποιήσετε τη λειτουργία Touch&Go. Η λειτουργία αυτή επιτρέπει, με το άνοιγμα και το κλείσιμο της βάνας, την ενεργοποίηση της στιγμιαίας προθέρμανσης, η οποία προετοιμάζει ζεστό νερό μόνο για τη συγκεκριμένη βάνα. Όταν η λειτουργία Touch&Go είναι ενεργοποιημένη, το T-G εμφανίζεται στην οθόνη (με P105 = 1 ΚΥΛΙΣΗ --> ΛΕΙΤΟΥΡΓΙΑ TOUCH&GO ΣΕ ΕΞΕΛΙΞΗ).

CSUP (λειτουργία ΕΞΥΠΝΗΣ προθέρμανσης): Όταν η λειτουργία είναι ενεργή, η μετακυκλοφορία για το τέλος του αιτήματος θέρμανσης πραγματοποιείται με τρεις διόδους που τοποθετούνται στο ΖΝΧ μέχρι να εκπληρωθεί μία από τις ακόλουθες συνθήκες:

- ΔΤ (αισθητήρας παροχής - επιστροφής) < 2°C

- Διάρκεια μετακυκλοφορίας > 20 δευτερόλεπτα

- Θερμοκρασία επιστροφής > 65°C.

Όταν η λειτουργία είναι ενεργοποιημένη, εμφανίζεται το PRHS στην οθόνη (με P105 = 1 κυλιόμενο μήνυμα --> ΛΕΙΤΟΥΡΓΙΑ ΕΞΥΠΝΗΣ ΠΡΟΘΕΡΜΑΝΣΗΣ ΣΕ ΕΞΕΛΙΞΗ).

5.7 Ειδικές λειτουργίες ζεστού νερού χρήσης

Ο λέβητας περιλαμβάνει αρχικά ΛΕΙΤΟΥΡΓΙΕΣ "ΛΕΙΤΟΥΡΓΙΕΣ ΖΕΣΤΟΥ ΝΕΡΟΥ ΧΡΗΣΗΣ", οι οποίες, ωστόσο, σε συνδυασμό με ένα DOSSERET, είναι προτιμότερο να μην ενεργοποιούνται καθώς οι ΔΕΞΑΜΕΝΕΣ του DOSSERET εκπληρώνουν αυτούς τους σκοπούς.

Η παράμετρος P511 σας επιτρέπει να ενεργοποιείτε ειδικές λειτουργίες κατά τη φάση διαμόρφωσης του ζεστού νερού χρήσης, αυτές οι λειτουργίες σας επιτρέπουν να βελτιώσετε την απόδοση του λέβητα σε ιδιαίτερα δύσκολες συνθήκες λειτουργίας (π.χ. ιδιαίτερα υψηλές θερμοκρασίες νερού εισόδου, πολύ χαμηλές παροχές, χρήση σε συνδυασμό με ηλιακά μπόιλερ).

0	Καμία ειδική λειτουργία δεν είναι ενεργή (προεπιλεγμένη τιμή)
1	Εισαγωγή της καθυστέρησης εκκίνησης του διακόπτη ροής/μετρητή ροής (παράμετρος P510 - ΣΕΡΒΙΣ)
2	Σε περίπτωση διακοπής λειτουργίας λόγω υπερθέρμανσης του ζεστού νερού χρήσης (με λήψη σε εξέλιξη), ο ανεμιστήρας διατηρείται στο ελάχιστο για να μειωθεί ο χρόνος αναμονής για επανεκκίνηση
3	Απόλυτοι θερμοστάτες ζεστού νερού χρήσης
4	Εξυπνη λειτουργία ζεστού νερού χρήσης έναντι ταλαντεύσεων
5	Οι τέσσερις προηγούμενες λειτουργίες ενεργές

Λειτουργία ΚΑΘΥΣΤΕΡΗΣΗ ΖΝΧ (1): Ενεργοποιώντας αυτήν τη λειτουργία, εισάγεται μια καθυστέρηση, ίση με την τιμή που ορίζεται στην παράμετρο P510, για την ενεργοποίηση της αντλίας και του ανεμιστήρα σε περίπτωση αιτήματος θερμότητας ζεστού νερού χρήσης.

Λειτουργία ΕΞΥΠΝΟΥ ΑΝΕΜΙΣΤΗΡΑ (2): Ενεργοποιώντας αυτήν τη λειτουργία, ο ανεμιστήρας διατηρείται στο ελάχιστο (MIN) και δεν απενεργοποιείται σε περίπτωση απενεργοποίησης του καυστήρα λόγω υπερθέρμανσης στο ΖΝΧ (ενώ εξακολουθεί να υφίσταται το αίτημα).

Λειτουργία ΑΠΟΛΥΤΩΝ ΘΕΡΜΟΣΤΑΤΩΝ (3): Ενεργοποιώντας αυτήν τη λειτουργία, οι θερμοστάτες ON/OFF του καυστήρα αλλάζουν από σχετική σε απόλυτη τιμή.

Λειτουργία ΕΝΑΝΤΙ ΤΑΛΑΝΤΕΥΣΕΩΝ (4): Ενεργοποιώντας αυτήν τη λειτουργία, ο λέβητας διαμορφώνεται αυτόματα σε ΑΠΟΛΥΤΟΥΣ ΘΕΡΜΟΣΤΑΤΕΣ σε περίπτωση απενεργοποίησης του καυστήρα λόγω υπερθέρμανσης στη λειτουργία ΖΝΧ (με λήψη σε εξέλιξη). Όταν ο καυστήρας είναι απενεργοποιημένος, ο ανεμιστήρας διατηρείται στο ελάχιστο. Οι θερμοστάτες γίνονται και πάλι «ΣΥΣΧΕΤΙΣΜΕΝΟΙ» στο τέλος της λήψης.

5.8 Λειτουργία θέρμανσης υποστρώματος

Ο λέβητας παρέχει, εάν το σύστημα βρίσκεται σε χαμηλή θερμοκρασία, μια λειτουργία «θέρμανσης υποστρώματος», η οποία μπορεί να ενεργοποιηθεί με τον ακόλουθο τρόπο:

- ρυθμίστε τον λέβητα στην κατάσταση OFF πατώντας το κουμπί (λειτουργία διαθέσιμη μόνο σε αυτήν την κατάσταση λειτουργίας)

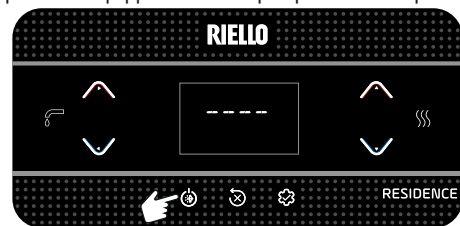

- αποκτήστε πρόσβαση στις τεχνικές παραμέτρους --> P4 --> P409 = 1 --> επιβεβαιώστε, στην οθόνη εμφανίζεται η ένδειξη (με P105 = 1 ΚΥΛΙΣΗ --> ΛΕΙΤΟΥΡΓΙΑ ΕΝΔΟΔΑΠΕΔΙΑΣ ΘΕΡΜΑΝΣΗΣ ΣΕ ΕΞΕΛΙΞΗ):



Η λειτουργία «θέρμανσης υποστρώματος» έχει διάρκεια 168 ωρών (7 ημέρες), κατά τη διάρκεια των οποίων, στις ζώνες που έχουν διαμορφωθεί ως χαμηλής θερμοκρασίας, προσομοιώνεται ένα αίτημα θέρμανσης με αρχικό σημείο ρύθμισης παροχής ζώνης ίσο με 20°C, αλλά η οποία σταδιακά αυξάνεται σύμφωνα με τον παρακάτω πίνακα.

Με την πρόσβαση στο μενού INFO από την κύρια οθόνη της διεπαφής, είναι δυνατή η εμφάνιση της τιμής I001 που αφορά τον αριθμό των ωρών που έχουν παρέλθει από την ενεργοποίηση της λειτουργίας. Μόλις ενεργοποιηθεί, η λειτουργία αποκτά απόλυτη προτεραιότητα, εάν το μηχανήμα απενεργοποιηθεί με την αφαίρεση της τάσης τροφοδοσίας. Όταν ενεργοποιηθεί ξανά, η λειτουργία συνεχίζεται από το σημείο που είχε διακοπεί. Η λειτουργία μπορεί να διακοπεί πριν από τη λήξη της, θέτοντας τον λέβητα σε κατάσταση διαφορετική από OFF ή επιλέγοντας P409=0 από το μενού P4.

ΗΜΕΡΑ	ΩΡΑ	ΘΕΡΜΟΚΡΑΣΙΑ
1	0	20°C
	6	22°C
	12	24°C
2	18	26°C
	0	28°C
	12	30°C
3	0	32°C
	4	35°C
5	0	35°C
	6	30°C
7	0	25°C

Σημείωση: Οι τιμές θερμοκρασίας και αύξησης μπορούν να ρυθμιστούν σε διαφορετικές τιμές αποκλειστικά από εξειδικευμένο προσωπικό, εάν είναι απολύτως απαραίτητο. Ο κατασκευαστής δεν φέρει καμία ευθύνη για εσφαλμένες ρυθμίσεις παραμέτρων. Στο μενού INFO, στη γραμμή I001 εμφανίζεται ο αριθμός των ωρών που έχουν παρέλθει από την ενεργοποίηση της λειτουργίας.

5.9 Έλεγχοι κατά τη διάρκεια και μετά την πρώτη θέση σε λειτουργία

Μετά τη θέση σε λειτουργία, βεβαιωθείτε ότι ο λέβητας εκτελεί σωστά τις διαδικασίες εκκίνησης και του επακόλουθου σβησίματος.

- Ελέγξτε επίσης τη λειτουργία ζεστού νερού χρήσης ανοίγοντας μια βρύση ζεστού νερού με την κατάσταση του λέβητα σε λειτουργία ΚΑΛΟΚΑΙΡΙ ή ΧΕΙΜΩΝΑΣ.
- Ελέγξτε την πλήρη διακοπή του λέβητα τοποθετώντας το γενικό διακόπτη της εγκατάστασης στη θέση "σβηστό".
- Μετά από μερικά λεπτά συνεχούς λειτουργίας και το γύρισμα του διακόπτη στη θέση «αναμμένο», ρυθμίζοντας την κατάσταση του λέβητα σε Καλοκαίρι και διατηρώντας ανοιχτή τη βρύση ζεστού νερού χρήσης, τα συνδετικά υλικά και τα υπολείμματα επεξεργασίας εξατμίζονται και μόνο τότε θα μπορείτε να ελέγξετε την καύση.

5.10 Έλεγχος καύσης

 Οι έλεγχοι των ρυθμίσεων των τιμών CO₂ σε σχέση με τις παραμέτρους αναφοράς, που εμφανίζονται στους παρακάτω πίνακες, πρέπει να πραγματοποιούνται με κλειστό το περίβλημα.

Πραγματοποιήστε την ανάλυση καύσης ως εξής:

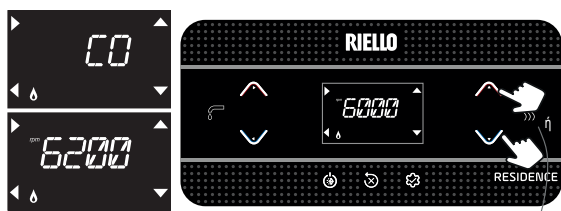
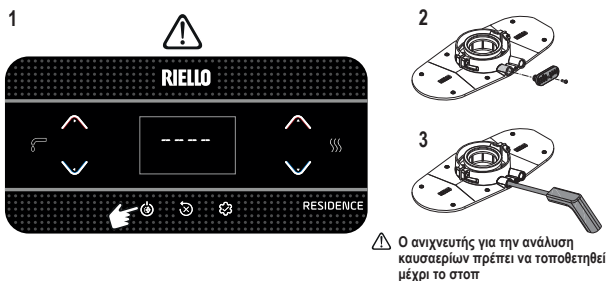

με P105 = 1 ΚΥΛΙΣΗ --> ΑΝΑΛΥΣΗ ΚΑΥΣΗΣ ΣΕ ΕΞΕΛΙΞΗ



- Στην οθόνη εμφανίζεται η ρυθμισμένη ταχύτητα για 10 δευτερόλεπτα μαζί με το εικονίδιο στροφών ανά λεπτό.
- Όταν ορίζεται η μέγιστη τιμή, ο λέβητας θα λειτουργεί στη μέγιστη ισχύ. Όταν ορίζεται η ελάχιστη τιμή, ο λέβητας θα λειτουργεί στην ελάχιστη ισχύ.



- Ελέγξτε στη συσκευή ανάλυσης ότι οι τιμές CO₂, **μέγιστη και ελάχιστη**, είναι σύμφωνες με τους ακόλουθους πίνακες.

CO ₂ * μεγ.		ΑΕΡΙΟ ΜΕΘΑΝΙΟΥ (G20)	ΥΓΡΟ ΑΕΡΙΟ (G31)	
	25 HM BIS		8,8	10,0
35 HM BIS		8,8	9,9	%
(*) Ανοχή CO ₂ = ±1%				

CO ₂ * ελάχ.		ΑΕΡΙΟ ΜΕΘΑΝΙΟΥ (G20)	ΥΓΡΟ ΑΕΡΙΟ (G31)	
	25 HM BIS		8,8	10,0
35 HM BIS		8,8	10,0	%
(*) Ανοχή CO ₂ = ±1%				

- Ελέγξτε ότι οι τιμές O₂ (μέγιστη, ονομαστική και ελάχιστη) για το μείγμα υδρογόνου 20% συμμορφώνονται με τα ακόλουθα.

Τιμή O ₂ σε σχέση με το μείγμα υδρογόνου 20%	Qmax	max	%	25 HM BIS	35 HM BIS
				ονομαστική	%
Qmin	min	max	%	4,3	4,3
				ονομαστική	%
		min	%	2,4	2,4
				ονομαστική	%
				6,2	6,2

- Ο ΑΝΑΛΥΣΗ ΚΑΥΣΗΣ έχει μέγιστη διάρκεια 15 λεπτά. Μπορείτε σε κάθε περίπτωση να τερματίσετε τη διαδικασία πρόωρα πατώντας το κουμπί B.
- Εάν το σύστημα βρίσκεται σε χαμηλή θερμοκρασία, σε απευθείας λειτουργία, χωρίς βαλβίδες ανάμειξης ή θερμοστατικές βαλβίδες, ο ΑΝΑΛΥΣΗ ΚΑΥΣΗΣ πρέπει να εκτελείται σε αίτημα ζεστού νερού χρήσης.

-  Ο ΑΝΑΛΥΣΗ ΚΑΥΣΗΣ διακόπτεται πρόωρα εάν:
 - η θερμοκρασία παροχής υπερβαίνει τους 95°C. Θα ανάψει ξανά όταν η θερμοκρασία θα πέσει κάτω από τους 75°C
 - δεν ανιχνεύεται φλόγα με αποτέλεσμα να σημειώνεται συναγερμός
 - σε περίπτωση συναγερμού.

-  Με συνδεδεμένη τη συσκευή OT+, η λειτουργία ελέγχου καύσης δεν μπορεί να ενεργοποιηθεί. Για να πραγματοποιήσετε την ανάλυση καπνών, θέστε την τιμή της παραμέτρου P803 σε 0. Ουμνηθείτε να επαναφέρετε την τιμή της παραμέτρου για να ενεργοποιήσετε ξανά τη σύνδεση OT+ στο τέλος της ανάλυσης καπνών.

Μόλις ολοκληρωθεί ο έλεγχος:

- βγείτε από τη λειτουργία πατώντας το κουμπί B
- αφαιρέστε τον αισθητήρα του αναλυτή και κλείστε την υποδοχή δειγματοληψίας ανάλυσης καύσης με την ειδική βίδα
- τοποθετήστε και αποθηκεύστε τον αντίστοιχο αισθητήρα ανάλυσης που παρέχεται με τον λέβητα στην τσάντα τεκμηρίωσης
- ρυθμίστε τον λέβητα στην επιθυμητή κατάσταση λειτουργίας ανάλογα με την εποχή
- ρυθμίστε τις απαιτούμενες τιμές θερμοκρασίας σύμφωνα με τις απαιτήσεις του πελάτη.

5.11 Ρυθμίσεις

Ο λέβητας έχει ήδη ρυθμιστεί κατά την κατασκευή από τον κατασκευαστή. Ωστόσο, εάν είναι απαραίτητο να πραγματοποιήσετε ξανά τις ρυθμίσεις (για παράδειγμα μετά από έκτακτη συντήρηση, μετά την αντικατάσταση της βαλβίδας αερίου, μετά από μετατροπή αερίου ή μετά την αντικατάσταση της πλακέτας) ακολουθήστε τις διαδικασίες που περιγράφονται παρακάτω. Οι ρυθμίσεις μέγιστης και ελάχιστης ισχύος και μέγιστης θέρμανσης πρέπει να πραγματοποιούνται μόνο από εξειδικευμένο προσωπικό:

P306	ελάχιστη ταχύτητα ανεμιστήρα
P307	μέγιστη ταχύτητα ανεμιστήρα
P309	μέγιστη ταχύτητα ανεμιστήρα θέρμανσης

- τροφοδοτήστε τον λέβητα
- αποκτήστε πρόσβαση στις τεχνικές παραμέτρους → **P3** → επιβεβαιώστε → επιλέξτε τη σχετική παράμετρο → επιβεβαιώστε
- ρυθμίστε τις επιθυμητές τιμές με τα κουμπιά C και/ή D, παραπέμποντας στους παρακάτω πίνακες
- επαληθεύστε ότι P309= P310.

⚠ Η μέγιστη ταχύτητα ανεμιστήρα θέρμανσης που χρησιμοποιείται θα είναι αυτή που ορίζεται στην παράμετρο P310.

Πίνακας 1			
ΜΕΓΙΣΤΟΣ ΑΡΙΘΜΟΣ ΣΤΡΟΦΩΝ ΑΝΕΜΙΣΤΗΡΑ	ΑΕΡΙΟ ΜΕΘΑΝΙΟΥ (G20)	ΥΓΡΟ ΑΕΡΙΟ (G31)	
25 HM BIS Θέρμ. - ZNX	6.300 - 7.900	6.100 - 7.600	στροφές ανά λεπτό
35 HM BIS Θέρμ. - ZNX	7.400 - 8.600	7.100 - 8.200	στροφές ανά λεπτό

Πίνακας 2			
ΕΛΑΧΙΣΤΟΣ ΑΡΙΘ. ΠΕΡΙΣΤΡΟΦΕΣ ΑΝΕΜΙΣΤΗΡΑ	ΑΕΡΙΟ ΜΕΘΑΝΙΟΥ (G20)	ΥΓΡΟ ΑΕΡΙΟ (G31)	
25 HM BIS	1.200	1.250	στροφές ανά λεπτό
35 HM BIS	1.300	1.250	στροφές ανά λεπτό

5.12 Μετατροπή αερίου

Ο λέβητας έχει σχεδιαστεί για λειτουργία με αέριο μεθανίου (G20), σύμφωνα με την ετικέτα του προϊόντος. Είναι δυνατή η μετατροπή του λέβητα σε υγραέριο (G31) μέσω της παραμέτρου P201.

⚠ Η μετατροπή από αέριο μιας οικογένειας προϊόντων σε αέριο άλλης οικογένειας, μπορεί εύκολα να γίνει ακόμη και με το λέβητα εγκατεστημένο.

⚠ Η εργασία αυτή πρέπει να διενεργείται από επαγγελματικά καταρτισμένο προσωπικό.

- Αποκτήστε πρόσβαση στις τεχνικές παραμέτρους → **P2** → P201 → επιβεβαιώστε.
- Χρησιμοποιήστε το πλήκτρο **C** ή **D** για να επιλέξετε την επιθυμητή επιλογή:
P201 = 1 (NG) - P201 = 2 (LPG) - P201 = 3 - P201 = 4.

⚠ **Επιβεβαιώστε την αλλαγή της παραμέτρου με ENTER και, στη συνέχεια, διακόψτε την παροχή ρεύματος στον λέβητα, για τουλάχιστον 10 δευτερόλεπτα..**

Μόλις αλλάξει η παράμετρος GAS, πρέπει να εκτελεστεί νέα διαδικασία «GAC» (βλ. παρ. 5.4). Ελέγξτε ότι οι στροφές του ανεμιστήρα αντιστοιχούν σε αυτό που υποδεικνύεται στους πίνακες 1 και 2, παρ. 5.11.

5.13 Έλεγχος πίεσης παροχής αερίου

Για να ελέγξετε την πίεση παροχής του αερίου:

- Κλείστε τη βάνα απομόνωσης αερίου στην είσοδο του λέβητα
- Χαλαρώστε τη βίδα της θύρας μέτρησης πίεσης πριν από τη βαλβίδα αερίου και συνδέστε τον σωλήνα σύνδεσης με το μανόμετρο
- Ανοίξτε τη βάνα απομόνωσης αερίου στην είσοδο του λέβητα
- Ενεργοποιήστε τη λειτουργία καπνοδοχοκαθαριστή
- Η σωστή τιμή πίεσης για κάθε τύπο αερίου αναφέρεται στον πίνακα "Τεχνικά δεδομένα"
- Μετά τον έλεγχο, απενεργοποιήστε τη λειτουργία καπνοδοχοκαθαριστή
- Κλείστε τη βάνα απομόνωσης αερίου στην είσοδο του λέβητα
- Αποσυνδέστε τον σωλήνα σύνδεσης με το μανόμετρο και σφίξτε ερμητικά τη βίδα της θύρας μέτρησης πίεσης πριν από τη βαλβίδα αερίου
- Ανοίξτε ξανά τη βάνα απομόνωσης αερίου στην είσοδο του λέβητα.

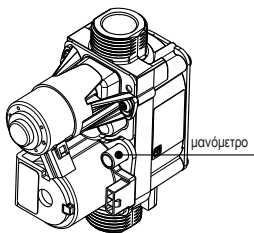

⚠ Η μη σύμφιση της βίδας της θύρας μέτρησης πίεσης μπορεί να προκαλέσει διαρροή καύσιμου αερίου.

⚠ Μετά από κάθε παρέμβαση στο κύκλωμα αερίου ή αέρα/αερίου, πρέπει να πραγματοποιείται έλεγχος στεγανότητας..

5.14 Ενδείξεις και ανωμαλίες

Σε περίπτωση ανωμαλίας, το εικονίδιο ⚠ αναβοσβήνει με συχνότητα 0,5 δευτερόλεπτα ON και 0,5 δευτερόλεπτα OFF, ο οπίσθιος φωτισμός αναβοσβήνει για 1 λεπτό με συχνότητα 1 δευτερόλεπτο ON και 1 δευτερόλεπτο OFF, και στη συνέχεια σβήνει, ενώ ο συναγερμός συνεχίζει να αναβοσβήνει. Ο κωδικός σφάλματος εμφανίζεται στα 4 ψηφία της οθόνης.



Όταν παρουσιάζεται ανωμαλία, ενδέχεται να εμφανιστούν τα ακόλουθα εικονίδια:

- ⚠ ανάβει όταν υπάρχει συναγερμός φλόγας (E010)
- Το RESET ανάβει όταν υπάρχει συναγερμός που απαιτεί χειροκίνητη απελευθέρωση από τον χρήστη (π.χ. μπλοκάρισμα φλόγας)
- ⚠ ανάβει μαζί με το εικονίδιο ⚠, με εξαίρεση τις ανωμαλίες μπλοκαρίσματος φλόγας και έλλειψης νερού

- ⚠ ανάβει όταν υπάρχουν συναγερμοί ή ενδείξεις που σχετίζονται με την πίεση του νερού, οπότε η τιμή της πίεσης του νερού εμφανίζεται εναλλακτικά με τον κωδικό ανωμαλίας κάθε 3 δευτερόλεπτα.

Λειτουργία απεμπλοκής

Για να επαναφέρετε τη λειτουργία του λέβητα σε περίπτωση ανωμαλίας, πρέπει να πατήσετε το κουμπί RESET.



Στο σημείο αυτό ο λέβητας, εάν έχουν αποκατασταθεί οι σωστές συνθήκες λειτουργίας, επανεκκινείται αυτόματα. Είναι δυνατές έως και 5 συνεχόμενες προσπάθειες ξεκλειδώματος του ίδιου συναγερμού από τη διεπαφή, μετά τις οποίες εμφανίζεται ο κωδικός σφάλματος E099 στην οθόνη.



Σε αυτήν την περίπτωση, είναι απαραίτητο να αποσυνδέσετε και να επανασυνδέσετε την ηλεκτρική τροφοδοσία στον λέβητα για να ενεργοποιήσετε ξανά τη λειτουργία.

⚠ Αν οι προσπάθειες απεμπλοκής δεν ενεργοποιούν τη λειτουργία του λέβητα, επικοινωνήστε με την Υπηρεσία Τεχνικής Υποστήριξης.

Ανωμαλίες E041

Σε περίπτωση που η τιμή της πίεσης πέσει κάτω από την τιμή ασφαλείας των 0,3 bar, ο λέβητας εμφανίζει τον κωδικό σφάλματος E041 για ένα μεταβατικό χρονικό διάστημα 10 λεπτών.

Μετά την παρέλευση του χρόνου μετάβασης, εάν η ανωμαλία εξακολουθεί να υφίσταται, εμφανίζεται ο κωδικός σφάλματος E040.

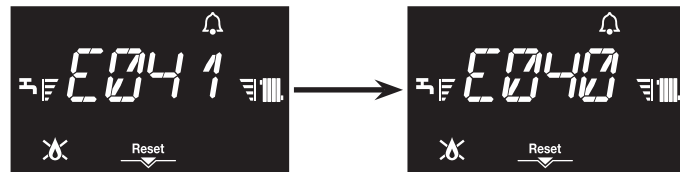

Με έναν λέβητα με ανωμαλία E040 είναι απαραίτητο να:

- ανοίξετε τη βάνα πλήρωσης (A) περιστρέφοντάς την αριστερόστροφα
- ελέγξετε ότι η τιμή της πίεσης φτάνει τα 1-1,5 bar χρησιμοποιώντας το υδρόμετρο που βρίσκεται κάτω από το υποστήριγμα ή με πρόσβαση στο μενού INFO («6.3 Μενού INFO» γραμμή I018)
- κλείσετε τη βάνα πλήρωσης (A), φροντίζοντας να ακούσετε το μηχανικό κλικ.

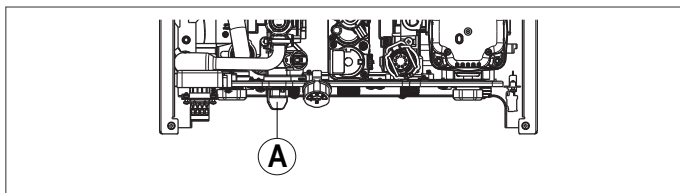

Πατήστε ⓧ για να αποκαταστήσετε τη λειτουργία.

Μόλις αποκατασταθεί η λειτουργία, ο λέβητας εκτελεί έναν αυτόματο κύκλο εξαέρωσης όπως περιγράφεται στην παράγραφο «4.10 Πλήρωση της εγκατάστασης θέρμανσης και εξαέρωση».

⚠ Εάν η πτώση της πίεσης είναι πολύ συχνή, ζητήστε την επέμβαση του Κέντρου Τεχνικής Εξυπηρέτησης.

Ανωμαλία E060

Ο λέβητας λειτουργεί κανονικά, αλλά δεν εξασφαλίζει τη σταθερότητα της θερμοκρασίας του ζεστού νερού χρήσης το οποίο, ωστόσο, παρέχεται σε μια θερμοκρασία κοντά στους 50°C. Απαιτείται η επέμβαση της Υπηρεσίας Τεχνικής Υποστήριξης.

Ανωμαλία E091

Ο λέβητας διαθέτει ένα σύστημα αυτόματης διάγνωσης το οποίο είναι σε θέση, με βάση τις συνολικές ώρες σε ειδικές συνθήκες λειτουργίας, να επιστημονεί την ανάγκη επέμβασης για τον καθαρισμό του πρωτεύοντα εναλλάκτη (κωδικός συναγερμού E091).

Μόλις ολοκληρωθεί η διαδικασία καθαρισμού, με το παρεχόμενο ειδικό kit ως αξεσουάρ, θα πρέπει να μηδενίσετε το μετρητή των συνολικών ωρών εφαρμόζοντας την ακόλουθη διαδικασία:

- αποκτήστε πρόσβαση στις τεχνικές παραμέτρους → **P3** → P312 → P312 = 1 → επιβεβαιώστε.

ΣΗΜΕΙΩΣΗ: Η διαδικασία μηδενισμού του μετρητή πρέπει να πραγματοποιείται μετά από κάθε προσεκτικό καθαρισμό του πρωτεύοντα εναλλάκτη ή σε περίπτωση αντικατάστασής του.

Η ανωμαλία E091 εμφανίζεται όταν ο μετρητής υπερβραίνει την τιμή των 2500 ωρών. αυτή η τιμή μπορεί να επαληθευτεί με τον ακόλουθο τρόπο:

- αποκτήστε πρόσβαση στο μενού INFO → I015 για να εμφανιστεί η τιμή του μετρητή του αισθητήρα καπνών (ένδειξη/100, παράδειγμα 2.500h = 25).

Ανωμαλίες E035-E036: Η εμφάνιση ειδοποίησης συναγερμού με κωδικό E035 ή E036, που απαιτεί μηδενισμό του συναγερμού μέσω του κεντρικού πλήκτρου, μπορεί να είναι φυσιολογική σε ορισμένες περιβαλλοντικές συνθήκες. Εάν η ειδοποίηση δεν είναι συχνή, πραγματοποιήστε τη διαδικασία μηδενισμού του συναγερμού χωρίς να απαιτείται τεχνική παρέμβαση.

5.15 Αντικατάσταση βαλβίδας αερίου (P205)

Μετά την αντικατάσταση της βαλβίδας αερίου, είναι απαραίτητο να επαναφέρετε την τιμή P1 της βαλβίδας αερίου (βλέπε φωτογραφία). Σε αυτήν την περίπτωση, ακολουθήστε την παρακάτω διαδικασία:

- θέστε τον λέβητα σε κατάσταση OFF
- αποκτήστε πρόσβαση στις παραμέτρους ρυθμίζοντας τον κωδικό πρόσβασης σύμφωνα με τις οδηγίες του κεφαλαίου 10 «Ρύθμιση κωδικού πρόσβασης, πρόσβαση και τροποποίηση παραμέτρων»
- με τα κουμπιά C ή D αποκτήστε πρόσβαση στην παράμετρο P2 → P205 και επιβεβαιώστε την επιλογή σας με το κουμπί A
- με τα κουμπιά C ή D πληκτρολογήστε το δεύτερο και το τρίτο ψηφίο της τιμής P1 (δηλαδή το 034 γίνεται 34) που είναι γραμμένο στη βαλβίδα αερίου του λέβητα (κάθε βαλβίδα αερίου έχει τη δική της τιμή μετατόπισης P1), επιβεβαιώστε με το κλειδί 3
- αποσυνδέστε την τροφοδοσία του λέβητα για τουλάχιστον 10 δευτερόλεπτα και, στη συνέχεια, επαναφέρετε την τροφοδοσία.

ΚΩΔΙΚΟΣ ΣΦΑΛΜΑΤΟΣ	ΜΗΝΥΜΑ ΣΦΑΛΜΑΤΟΣ	ΠΕΡΙΓΡΑΦΗ ΤΥΠΟΥ ΣΥΝΑΓΕΡΜΟΥ
E010	ΑΣΤΟΧΙΑ ΕΝΑΥΣΗΣ	
E011	ΠΑΡΑΣΙΤΙΚΗ ΦΛΟΓΑ	
E012	ΜΕΓΙΣΤΟΣ ΑΡΙΘΜΟΣ ΑΠΩΛΕΙΑΣ ΦΛΟΓΑΣ	
E013	ΑΠΟΤΥΧΙΑ ΕΛΕΓΧΟΥ ΕΞΑΡΤΗΜΑΤΟΣ	
E014	ΑΠΟΤΥΧΙΑ ΕΛΕΓΧΟΥ ΑΝΙΧΝΕΥΣΗΣ ΦΛΟΓΑΣ	
E015	ΑΠΟΤΥΧΙΑ ΕΛΕΓΧΟΥ ΑΝΙΧΝΕΥΣΗΣ ΡΕΥΜΑΤΟΣ ΙΟΝΙΣΜΟΥ	
E020	ΘΕΡΜΟΣΤΑΤΗΣ ΟΡΙΟΥ	
E021	ΔΥΣΛΕΙΤΟΥΡΓΙΑ ΕΛΕΓΧΟΥ ΒΑΛΒΙΔΑΣ ΑΕΡΙΟΥ	
E030	ΣΦΑΛΜΑ ΑΝΕΜΙΣΤΗΡΑ	
E031	ΜΗΧΑΝΙΚΗ ΕΜΠΛΟΚΗ ΑΝΕΜΙΣΤΗΡΑ	
E032	ΕΜΠΛΟΚΗ ΦΤΕΡΩΤΗΣ ΑΝΕΜΙΣΤΗΡΑ	
E033	ΚΑΤΕΣΤΡΑΜΕΝΗ ΦΤΕΡΩΤΗ ΑΝΕΜΙΣΤΗΡΑ	
E034	ΦΡΑΓΜΕΝΗ ΚΑΜΙΝΑΔΑ ΚΑΤΑ ΤΟΝ ΠΡΟΑΕΡΙΣΜΟ	
E035	ΑΠΟΦΡΑΞΗ ΚΑΥΣΑΕΡΙΩΝ ΣΤΗ ΧΑΜΗΛΗ ΙΣΧΥ	
E036	ΑΠΟΦΡΑΞΗ ΚΑΥΣΑΕΡΙΩΝ ΣΤΗΝ ΥΨΗΛΗ ΙΣΧΥ	
E037	ΑΠΟΤΥΧΙΑ ΕΛΕΓΧΟΥ ΚΑΥΣΗΣ ΣΤΗ ΧΑΜΗΛΗ ΙΣΧΥ	
E038	ΑΠΟΤΥΧΙΑ ΕΛΕΓΧΟΥ ΚΑΥΣΗΣ ΣΤΗΝ ΥΨΗΛΗ ΙΣΧΥ	
E039	ΜΗ ΦΥΣΙΟΛΟΓΙΚΗ ΤΙΜΗ ΦΛΟΓΑΣ	
E040 + τιμή bar	ΠΙΕΣΗ ΝΕΡΟΥ ΠΛΗΡΩΣΗΣ ΣΥΣΤΗΜΑΤΟΣ	
E042	ΣΦΑΛΜΑ ΜΕΤΑΤΡΟΠΕΑ ΠΙΕΣΗΣ ΝΕΡΟΥ	
E071	ΥΠΕΡΘΕΡΜΑΝΣΗ ΑΙΣΘΗΤΗΡΙΟΥ ΘΕΡΜΑΝΣΗΣ	
E072	ΕΠΙΣΤΡΟΦΗ - ΔΙΑΦΟΡΑ ΡΟΗΣ	
E075	ΕΠΙΤΕΥΞΗ ΟΡΙΟΥ ΑΝΟΙΓΜΑΤΟΣ ΒΑΛΒΙΔΑΣ	
E088	ΚΡΑΤΗΜΕΝΟΣ ΣΥΝΑΓΕΡΜΟΣ	
E092	ΑΠΟΤΥΧΗΜΕΝΗ ΒΑΘΜΟΝΟΜΗΣΗ, ΥΠΕΡΒΟΛΙΚΟΣ ΑΡΙΘΜΟΣ ΒΑΘΜΟΝΟΜΗΣΕΩΝ ΜΕΣΑ ΣΕ ΜΙΑ ΩΡΑ	
E093	Η ΒΑΘΜΟΝΟΜΗΣΗ ΑΠΕΤΥΧΕ, ΠΑΡΑ ΠΟΛΛΕΣ ΑΝΕΠΙΤΥΧΕΙΣ ΠΡΟΣΠΑΘΕΙΕΣ ΒΑΘΜΟΝΟΜΗΣΗΣ	
E094	ΥΠΕΡΒΑΣΗ ΟΡΙΟΥ LAMBDA	
E097	ΕΛΕΓΧΟΣ ΑΠΟΤΥΧΙΑ (έχει ανιχνευθεί λανθασμένο επίπεδο καύσης)	
E098	ΕΧΕΙ ΕΝΤΟΠΙΣΤΕΙ ΛΑΝΘΑΣΜΕΝΟ ΕΠΙΠΕΔΟ ΚΑΥΣΗΣ	
E099	ΕΞΑΝΤΛΗΘΗΚΑΝ ΟΙ ΑΠΟΠΕΙΡΕΣ ΕΠΑΝΑΤΑΞΗΣ	
E041 + τιμή bar	ΠΙΕΣΗ ΝΕΡΟΥ ΠΛΗΡΩΣΗΣ ΣΥΣΤΗΜΑΤΟΣ	
E050	ΣΦΑΛΜΑ ΑΠΟΦΡΑΞΗΣ ΚΑΥΣΑΕΡΙΩΝ ΣΤΗ ΧΑΜΗΛΗ ΙΣΧΥ	
E051	ΣΥΝΕΠΕΙΑ ΡΥΘΜΙΣΗΣ ΠΟΥ ΠΡΑΓΜΑΤΟΠΟΙΗΘΗΚΕ ΣΕ ΚΑΘΕΣΤΩΣ ΑΣΤΑΘΕΙΑΣ ΦΛΟΓΑΣ/ΑΠΟΦΡΑΞΗΣ	
E052	ΣΦΑΛΜΑ ΕΞΑΡΤΗΜΑΤΟΣ ΕΚΤΟΣ ΚΑΤΩΤΑΤΟΥ ΟΡΙΟΥ	
E055	ΑΠΩΛΕΙΑ ΕΠΙΚΟΙΝΩΝΙΑΣ ΠΛΑΚΕΤΑΣ ΑΝΕΜΙΣΤΗΡΑ	
E056	ΑΠΩΛΕΙΑ ΕΠΙΚΟΙΝΩΝΙΑΣ ΚΑΡΤΑ ΜΙΚΡΟΕΠΕΞΕΡΓΑΣΤΗ	
E060	ΣΦΑΛΜΑ ΑΙΣΘΗΤΗΡΙΟΥ ΖΝΧ	
E070	ΣΦΑΛΜΑ ΑΙΣΘΗΤΗΡΙΟΥ ΘΕΡΜΑΝΣΗΣ	
E071	ΥΠΕΡΘΕΡΜΑΝΣΗ ΑΙΣΘΗΤΗΡΙΟΥ ΘΕΡΜΑΝΣΗΣ	
E072	ΕΠΙΣΤΡΟΦΗ - ΔΙΑΦΟΡΑ ΡΟΗΣ	
E077	ΘΕΡΜΟΣΤΑΤΗΣ ΝΕΡΟΥ ΚΥΡΙΑΣ ΖΩΝΗΣ	
E080	ΔΥΣΛΕΙΤΟΥΡΓΙΑ ΑΙΣΘΗΤΗΡΙΟΥ ΕΠΙΣΤΡΟΦΗΣ	
E081	ΥΠΕΡΘΕΡΜΑΝΣΗ ΑΙΣΘΗΤΗΡΙΟΥ ΕΠΙΣΤΡΟΦΗΣ	
E082	ΠΡΟΣΑΓΩΓΗ - ΔΙΑΦΟΡΑ ΡΟΗΣ	
E090	ΔΥΣΛΕΙΤΟΥΡΓΙΑ ΑΙΣΘΗΤΗΡΙΟΥ ΚΑΥΣΑΕΡΙΩΝ	
E091	ΚΑΘΑΡΙΣΜΟΣ ΚΥΡΙΟΥ ΕΝΑΛΛΑΚΤΗ ΘΕΡΜΟΤΗΤΑΣ	
E095	ΑΠΟΤΥΧΙΑ ΒΑΘΜΟΝΟΜΗΣΗΣ	
E096	ΥΠΕΡΒΑΣΗ ΟΡΙΟΥ LAMBDA	
FIL + τιμή bar	ΧΑΜΗΛΗ ΠΙΕΣΗ ΝΕΡΟΥ ΕΛΕΓΞΤΕ ΤΗΝ ΕΓΚΑΤΑΣΤΑΣΗ	
αναβοσβήνει + τιμή bar	ΥΨΗΛΗ ΠΙΕΣΗ ΝΕΡΟΥ ΕΛΕΓΞΤΕ ΤΗΝ ΕΓΚΑΤΑΣΤΑΣΗ	ΣΗΜΑΝΣΗ
COM	ΑΠΩΛΕΙΑ ΕΠΙΚΟΙΝΩΝΙΑΣ ΠΙΝΑΚΑ ΕΛΕΓΧΟΥ ΛΕΒΗΤΑ (για περισσότερο από 30 δευτερόλεπτα)	ΣΗΜΑΝΣΗ: (ο λέβητας συνεχίζει να λειτουργεί αλλά χωρίς οθόνη ή κουμπιά)
E066	Η ΕΠΙΚΟΙΝΩΝΙΑ DOSSERET ΧΑΘΗΚΕ	ΣΗΜΑΝΣΗ
FWER	ΠΡΟΕΙΔΟΠΟΙΗΣΗ ΜΗ ΣΥΜΒΑΤΟΥ ΛΟΓΙΣΜΙΚΟΥ	ΣΗΜΑΝΣΗ: (ο λέβητας συνεχίζει να λειτουργεί αλλά χωρίς οθόνη ή κουμπιά)
CFS	ΚΑΛΕΣΤΕ ΓΙΑ ΣΥΝΤΗΡΗΣΗ	ΣΗΜΑΝΣΗ
SFS	ΔΙΑΚΟΠΗ ΛΕΙΤΟΥΡΓΙΑΣ ΓΙΑ ΣΥΝΤΗΡΗΣΗ	ΟΡΙΣΤΙΚΟΣ
OBCD	ΒΛΑΒΗ ΕΝΣΩΜΑΤΩΜΕΝΟΥ ΡΟΛΟΓΙΟΥ	ΣΗΜΑΝΣΗ: (ο λέβητας συνεχίζει να λειτουργεί αλλά χωρίς οθόνη ή κουμπιά)

ΟΡΙΣΤΙΚΟΙ

ΜΕΤΑΒΑΤΙΚΟΙ

Μόλις ολοκληρωθεί η αντικατάσταση, εκτελέστε μια νέα διαδικασία «GAC» (βλ. κεφάλαιο 5.4).



Εάν αντικατασταθεί η βαλβίδα αερίου, αντικαταστήστε επίσης τις σχετικές φλάντζες στεγανοποίησης.

Για να σφίξετε το παξιμάδι της ράμπας της βαλβίδας αερίου, εφαρμόστε ροπή ίση με 25 Nm, περιορίζοντας την περιστροφή της βαλβίδας.



5.16 Αντικατάσταση διεπαφής

Οι εργασίες διαμόρφωσης του συστήματος πρέπει να εκτελούνται από επαγγελματικά καταρτισμένο προσωπικό της Υπηρεσίας Τεχνικής Υποστήριξης.

Εάν αντικατασταθεί η πλακέτα της διεπαφής, μπορεί να ζητηθεί από τον χρήστη να επαναφέρει τις τιμές της ώρας και της ημέρας της εβδομάδας κατά την ενεργοποίηση (βλέπε «5.2 Πρώτη θέση σε λειτουργία»), ελέγξτε επίσης και επαναφέρετε, εάν είναι απαραίτητο, τις πληροφορίες σχετικά με τον ωριαίο προγραμματισμό θέρμανσης και ζεστού νερού χρήσης (βλέπε «8.1 Λειτουργία ωριαίου προγράμματος (θερμοστάτη χώρου)») και τη λειτουργία φιαλών (βλέπε «8.12 Λειτουργία ΤΡΟΦΟΔΟΤΗ ΦΙΑΛΩΝ»). Σημειώστε ότι δεν απαιτείται επαναπρογραμματισμός των παραμέτρων διαμόρφωσης, η τιμή των οποίων ανακτάται από την πλακέτα ρύθμισης και ελέγχου του λέβητα.

Αντ' αυτού, μπορεί να χρειαστεί να επαναφέρετε τις τιμές σημείου ρύθμισης του ζεστού νερού χρήσης και/ή της θέρμανσης.

5.17 Αντικατάσταση πλακέτας

Εάν αντικατασταθεί η πλακέτα ελέγχου και ρύθμισης, ενδέχεται να χρειαστεί επαναπρογραμματισμός των παραμέτρων διαμόρφωσης. Μετά την αντικατάσταση της πλακέτας, συνιστούμε να πραγματοποιήσετε μια αρχική διαδικασία PAR. Συμβουλευτείτε τον πίνακα παραμέτρων για να προσδιορίσετε τις προεπιλεγμένες τιμές πλακέτας, τις εργοστασιακές τιμές και τις προσαρμοσμένες τιμές.

Οι παράμετροι που πρέπει απαραίτητα να ελεγχθούν και ενδεχομένως να επαναφερθούν είναι: P201 • P205 (με λέβητα σε θέση OFF) • P208 • P301 • P302 (ΣΕΡΒΙΣ) • P306 • P307 • P309 • P310.

Αποσυνδέστε την τροφοδοσία του λέβητα για τουλάχιστον 10 δευτερόλεπτα και, στη συνέχεια, επαναφέρετε την τροφοδοσία.

Μόλις ολοκληρωθεί η αντικατάσταση, εκτελέστε μια νέα διαδικασία «GAC» (βλ. κεφάλαιο 5.4).

6 ΣΥΝΤΗΡΗΣΗ ΚΑΙ ΚΑΘΑΡΙΣΜΟΣ



Η περιοδική συντήρηση είναι μια «υποχρέωση» που απαιτείται από τον νόμο και είναι απαραίτητη για την ασφάλεια, την απόδοση και τη διάρκεια του λέβητα. Επιτρέπεται να μειωθεί η καταναλώση, οι εκπομπές ρύπων και να διατηρηθεί η ασφάλεια και η αξιοπιστία του προϊόντος στον χρόνο.

Η συντήρηση του λέβητα πρέπει να γίνεται τουλάχιστον μία φορά ετησίως και να προγραμματίζεται έγκαιρα με την Υπηρεσία Τεχνικής Υποστήριξης.

Πριν ξεκινήσετε τις εργασίες συντήρησης:

- Κλείστε τις βάνες καυσίμου και νερού της εγκατάστασης θέρμανσης και ζεστού νερού χρήσης.

Για να εξασφαλίσετε τη διατήρηση των χαρακτηριστικών λειτουργικότητας και αποτελεσματικότητας του προϊόντος και για να τηρήσετε τις προδιαγραφές της ισχύουσας νομοθεσίας, θα πρέπει να υποβάλετε τη συσκευή σε συστηματικούς ελέγχους ανά τακτά χρονικά διαστήματα. Για τη συντήρηση, ακολουθήστε τις οδηγίες του κεφαλαίου «1 ΟΔΗΓΙΕΣ ΠΡΟΦΥΛΑΞΗΣ ΚΑΙ ΑΣΦΑΛΕΙΑΣ».

Κατά κανόνα πρέπει να γίνονται οι ακόλουθες ενέργειες:

- απομάκρυνση τυχόν οξειδώσεων από τον καυστήρα
- απομάκρυνση τυχόν επικαθίσεων από τους εναλλάκτες
- έλεγχος της κατάστασης φθοράς των ηλεκτροδίων και, εάν έχουν φθαρεί, την αντικατάστασή τους μαζί με τις τσιμούχες τους
- έλεγχος και γενικός καθαρισμός των αγωγών εκκένωσης και αναρρόφησης
- έλεγχος της εξωτερικής εμφάνισης του λέβητα
- έλεγχος ενεργοποίησης, απενεργοποίησης και λειτουργίας της συσκευής τόσο για ζεστό νερό οικιακής χρήσης όσο και για θέρμανση

- έλεγχος στεγανότητας ρακόρ και σωληνώσεων σύνδεσης αερίου, νερού και συμπυκνώματος
- έλεγχος κατανάλωσης αερίου με τη μέγιστη και την ελάχιστη ισχύ
- εάν η πίεση του ζεστού νερού χρήσης είναι μικρότερη από 3 bar, αδειάστε το κύκλωμα ζεστού νερού χρήσης του λέβητα και ελέγξτε ότι διατηρείται η πίεση του κυκλώματος θέρμανσης
- έλεγχος της ακεραιότητας της μόνωσης των ηλεκτρικών καλωδίων, ιδίως κοντά στον πρωτεύοντα εναλλάκτη
- έλεγχος ασφάλειας έλλειψης αερίου
- έλεγχος και καθαρισμός του σιφονιού
- έλεγχος καθαριότητας του ανεμιστήρα, εσωτερική εξαγωγή (συμπεριλαμβανομένου του φίλτρου αέρα όταν παρέχεται)
- έλεγχος ότι υπάρχει νερό στο σιφόνι, διαφορετικά επαναπληρώστε το.



Η ηλεκτρονική πλακέτα και η βαλβίδα αερίου δεν απαιτούν ειδικό έλεγχο με στόχο την αξιολόγηση της γήρανσης και της φθοράς.



Κατά τη διάρκεια της συντήρησης του λέβητα, συνιστάται η χρήση προστατευτικού ρουχισμού για την αποφυγή τραυματισμών.



Αφού ολοκληρώσετε τις εργασίες συντήρησης πρέπει να πραγματοποιήσετε μια ανάλυση των προϊόντων καύσης προκειμένου να επαληθευτεί η σωστή λειτουργία.



Μην καθαρίζετε τη συσκευή ούτε τα μέρη αυτής με εύφλεκτες ουσίες (π.χ. βενζίνη, οινόπνευμα, κτλ.).



Μην καθαρίζετε τα ταμπλό, τα βαμμένα και τα πλαστικά μέρη με διαλυτικά για βερνίκια.



Ο καθαρισμός του ταμπλό πρέπει να γίνεται μόνο με σαπουνόνερο.

Εκτελέστε μια νέα διαδικασία "GAR", στη συνέχεια αφαιρέστε την τροφοδοσία για τουλάχιστον 10 δευτερόλεπτα και τέλος εκτελέστε μια νέα διαδικασία "GAC" (βλ. παρ. 5.4), στις ακόλουθες περιπτώσεις:

- τροποποίηση του αγωγού εισαγωγής και εξαγωγής
- καθαρισμός του πρωτογενούς εναλλάκτη
- αντικατάσταση ηλεκτροδίων ανάφλεξης και ανίχνευσης φλόγας
- αντικατάσταση του πρωτεύοντα εναλλάκτη καυτή του μεταφορέα.

Εκτελέστε μια νέα διαδικασία "GAR", στη συνέχεια αφαιρέστε την τροφοδοσία για τουλάχιστον 10 δευτερόλεπτα και τέλος εκτελέστε μια νέα διαδικασία "GAC" (βλ. παρ. 5.4) μόνο εάν μια ανάλυση των προϊόντων καύσης είναι εκτός ανοχής στις ακόλουθες περιπτώσεις:

- καθαρισμός καυστήρα
- καθαρισμός μεταφορέα
- καθαρισμός ανεμιστήρα
- αντικατάσταση/καθαρισμός μίκτη ανεμιστήρα.

Καθαρισμός πρωτεύοντα εναλλάκτη

- Διακόψτε την ηλεκτρική τροφοδοσία γυρίζοντας τον γενικό διακόπτη της εγκατάστασης στη θέση «σβηστό».
- Κλείστε τις βάνες διακοπής αερίου.
- Αφαιρέστε το περιβλήμα, όπως υποδεικνύεται στην παράγραφο «4.7 Αφαίρεση του περιβλήματος».
- Αποσυνδέστε το καλώδιο σύνδεσης των ηλεκτροδίων ανάφλεξης και ανίχνευσης.
- Αποσυνδέστε τα καλώδια τροφοδοσίας του ανεμιστήρα.
- Τραβήξτε το κλιπ στερέωσης της γραμμής έξω από τον μείκτη.
- Χαλαρώστε το παξιμάδι της γραμμής αερίου.
- Αφαιρέστε τη γραμμή αερίου από τον μείκτη και γυρίστε την.
- Αφαιρέστε τα 4 παξιμάδια που ασφαλίζουν το συγκρότημα καύσης.
- Αφαιρέστε το συγκρότημα του αγωγού αέρα/αερίου, συμπεριλαμβανομένου του ανεμιστήρα και του μείκτη, προσέχοντας να μην καταστραφεί το μονωτικό πάνελ και το ηλεκτρόδιο.
- Αφαιρέστε τον σωλήνα σύνδεσης σιφονιού από το ρακόρ εκκένωσης συμπυκνωμάτων του εναλλάκτη και συνδέστε έναν προσωρινό σωλήνα συλλογής. Σε αυτό το σημείο συνεχίστε με τον καθαρισμό του εναλλάκτη.
- Απομακρύνετε με ηλεκτρική σκούπα τυχόν υπολείμματα βρομιάς στο εσωτερικό του εναλλάκτη, προσέχοντας να ΜΗΝ καταστρέψετε το μονωτικό πάνελ του επιβραδυντή.
- Καθαρίστε τις στείρες του εναλλάκτη με μια βούρτσα με μαλακές τρίχες.



ΜΗ ΧΡΗΣΙΜΟΠΟΙΕΙΤΕ ΜΕΤΑΛΛΙΚΕΣ ΒΟΥΡΤΣΕΣ ΠΟΥ ΜΠΟΡΕΙ ΝΑ ΠΡΟΚΑΛΕΣΟΥΝ ΖΗΜΙΑ ΣΤΑ ΕΞΑΡΤΗΜΑΤΑ.

- Καθαρίστε τα κενά μεταξύ των σπειρών χρησιμοποιώντας μια λεπίδα πάχους 0,4 mm, που ενδεχομένως διατίθεται σε μορφή kit.
- Σκουπίστε με ηλεκτρική σκούπα τυχόν υπολείμματα από τον καθαρισμό.
- Ξεπλύνετε με νερό, προσέχοντας να ΜΗΝ καταστρέψετε το μονωτικό πάνελ του επιβραδυντή.



Σε περίπτωση επίμονων καταθέσεων προϊόντων καύσης στην επιφάνεια του εναλλάκτη θερμότητας, συνιστούμε τη χρήση προϊόντων της σειράς Total Defence, προσέχοντας να ΜΗΝ καταστρέψετε το μονωτικό πάνελ retarder.

- Αφήστε το να δράσει για λίγα λεπτά.
- Καθαρίστε τις στείρες του εναλλάκτη με μια βούρτσα με μαλακές τρίχες.

⚠ ΜΗ ΧΡΗΣΙΜΟΠΟΙΕΙΤΕ ΜΕΤΑΛΛΙΚΕΣ ΒΟΥΡΤΣΕΣ ΠΟΥ ΜΠΟΡΕΙ ΝΑ ΠΡΟΚΑΛΕΣΟΥΝ ΖΗΜΙΑ ΣΤΑ ΕΞΑΡΤΗΜΑΤΑ.

- Ξεπλύνετε με νερό, προσέχοντας να ΜΗΝ καταστρέψετε το μονωτικό πάνελ του επιβραδυντή.
- Ελέγξτε την ακεραιότητα του μονωτικού πάνελ του επιβραδυντή και αντικαταστήστε το εάν είναι απαραίτητο, ακολουθώντας την κατάλληλη διαδικασία.
- Μετά τον καθαρισμό, συναρμολογήστε ξανά με τη δέουσα προσοχή τα εξαρτήματα προς την αντίθετη κατεύθυνση όπως περιγράφεται.
- Για να σφίξετε τα παξιμάδια στερέωσης του συγκροτήματος του αγωγού αέρα/αερίου, χρησιμοποιήστε ροπή σύσφιξης 6 Nm, ακολουθώντας τη σειρά που υποδεικνύεται στη θήκη (1,2,3,4)
- Επαναφέρετε την τάση και την τροφοδοσία αερίου στον λέβητα.

⚠ Εκτελέστε μια νέα διαδικασία "GAR", στη συνέχεια αφαιρέστε την τροφοδοσία για τουλάχιστον 10 δευτερόλεπτα και τέλος εκτελέστε μια νέα διαδικασία "GAC" (βλ. παρ. 5.4).

⚠ Αυτό που υποδεικνύεται ισχύει και στην περίπτωση αντικατάστασης μόνο του μεταφορέα, του εναλλάκτη ή του συγκροτήματος μεταφορέα και εναλλάκτη.

Καθαρισμός καυστήρα:

- Διακόψτε την ηλεκτρική τροφοδοσία γυρίζοντας τον γενικό διακόπτη της εγκατάστασης στη θέση «σβηστό».
- Κλείστε τις βάνες διακοπής αερίου.
- Αφαιρέστε το περίβλημα, όπως υποδεικνύεται στην παράγραφο «4.7 Αφαίρεση του περιβλήματος».
- Αποσυνδέστε το καλώδιο σύνδεσης των ηλεκτροδίων ανάφλεξης και ανίχνευσης.
- Αποσυνδέστε τα καλώδια τροφοδοσίας του ανεμιστήρα.
- Τραβήξτε το κλιπ στερέωσης της γραμμής έξω από τον μείκτη.
- Χαλαρώστε το παξιμάδι της γραμμής αερίου.
- Αφαιρέστε τη γραμμή αερίου από τον μείκτη και γυρίστε την.
- Αφαιρέστε τα 4 παξιμάδια που ασφαλίζουν το συγκρότημα καύσης.
- Αφαιρέστε το συγκρότημα του αγωγού αέρα/αερίου, συμπεριλαμβανομένου του ανεμιστήρα και του μείκτη, προσέχοντας να μην καταστραφεί το κεραμικό μονωτικό πάνελ και τα ηλεκτρόδια. Σε αυτό το σημείο συνεχίστε με τον καθαρισμό του καυστήρα.
- Καθαρίστε τον καυστήρα με μια βούρτσα με μαλακές τρίχες, προσέχοντας να μην καταστρέψετε το μονωτικό πάνελ και τα ηλεκτρόδια.

⚠ ΜΗ ΧΡΗΣΙΜΟΠΟΙΕΙΤΕ ΜΕΤΑΛΛΙΚΕΣ ΒΟΥΡΤΣΕΣ ΠΟΥ ΜΠΟΡΕΙ ΝΑ ΠΡΟΚΑΛΕΣΟΥΝ ΖΗΜΙΑ ΣΤΑ ΕΞΑΡΤΗΜΑΤΑ.

- Ελέγξτε την ακεραιότητα του μονωτικού πάνελ του καυστήρα και τις τσιμούχες και, εάν είναι απαραίτητο, αντικαταστήστε τα ακολουθώντας την κατάλληλη διαδικασία.
- Μετά τον καθαρισμό, συναρμολογήστε ξανά με τη δέουσα προσοχή τα εξαρτήματα προς την αντίθετη κατεύθυνση όπως περιγράφεται.
- Για να σφίξετε τα παξιμάδια στερέωσης του συγκροτήματος του αγωγού αέρα/αερίου, χρησιμοποιήστε ροπή σύσφιξης 6 Nm.
- Επαναφέρετε την τάση και την τροφοδοσία αερίου στον λέβητα.

⚠ Εκτελέστε ανάλυση προϊόντος καύσης. Μόνο εάν επιστρέψει τιμές εκτός ανοχής, είναι απαραίτητο να πραγματοποιηθεί μια νέα διαδικασία "GAR", στη συνέχεια να αφαιρεθεί η τροφοδοσία για τουλάχιστον 10 δευτερόλεπτα και, τέλος, μια νέα διαδικασία "GAC" (βλ. παρ.).

⚠ Αυτό που υποδεικνύεται ισχύει και στην περίπτωση αντικατάστασης μόνο του μεταφορέα, του εναλλάκτη ή του συγκροτήματος μεταφορέα και εναλλάκτη.

Αντικατάσταση μονωτικού πάνελ καυστήρα

- Ξεβιδώστε τις βίδες που συγκρατούν το ηλεκτρόδιο ανάφλεξης/ανίχνευσης και αφαιρέστε το.
- Αφαιρέστε το μονωτικό πάνελ του καυστήρα ενεργώντας με μια λεπίδα κάτω από την επιφάνεια (όπως φαίνεται στο σχήμα).
- Καθαρίστε τυχόν υπολείμματα κόλλας στερέωσης.
- Αντικαταστήστε το μονωτικό πάνελ καυστήρα.
- Το νέο μονωτικό πάνελ που χρησιμοποιείται για να αντικαταστήσει αυτό που αφαιρείται δεν απαιτεί στερέωση με κόλλα, καθώς η γεωμετρία του εξασφαλίζει παρεμβολή κατά τη σύζευξη με τη φλάντζα του εναλλάκτη.
- Τοποθετήστε ξανά τα ηλεκτρόδια ανάφλεξης και ανίχνευσης χρησιμοποιώντας τις βίδες που έχουν αφαιρεθεί προηγουμένως και αντικαθιστώντας τη σχετική τσιμούχα. Για να σφίξετε τις βίδες, εφαρμόστε ροπή 2,3 Nm.

⚠ Μην εκτελείτε GAR ή/και GAC.

Έλεγχος και καθαρισμός σιφονιού

- Αποσυνδέστε τα σωληνάκια (A - B), ξεβιδώστε τη βίδα (C), βγάλτε το κλιπ (D) και αντικαταστήστε το σιφόνι.
- Καθαρίστε τα μέρη του σιφονιού από τυχόν στερεά υπολείμματα.

⚠ Τοποθετήστε ξανά με προσοχή τα εξαρτήματα που αφαιρέσατε προηγουμένως.

⚠ Στο τέλος της ακολουθίας καθαρισμού, γεμίστε το σιφόνι με νερό (βλ. παράγραφο «5.2 Πρώτη θέση σε λειτουργία») πριν θέσετε ξανά σε λειτουργία τον λέβητα.

⚠ Μην εκτελείτε GAR ή/και GAC.

⚠ Ό,τι υποδεικνύεται ισχύει και στην περίπτωση αντικατάστασης του σιφονιού.

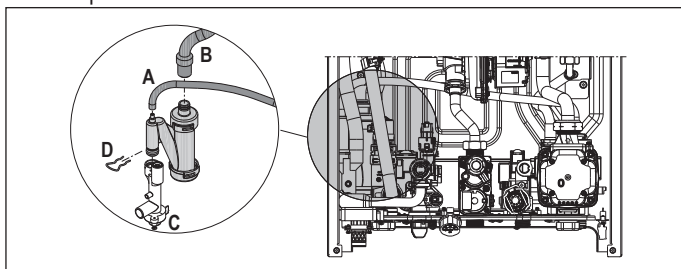

Ηλεκτρόδια ανάφλεξης και ανίχνευσης

Τα ηλεκτρόδια του αισθητήρα ανάφλεξης και ανίχνευσης/ιονισμού εκτελούν σημαντική λειτουργία στη φάση ανάφλεξης του λέβητα και στη διατήρηση της σωστής καύσης. Από την άποψη αυτή, κατά τη διάρκεια της ετήσιας συντήρησης, είναι απαραίτητο να ελέγχετε πάντα ότι είναι σωστά τοποθετημένα και ότι τηρούνται αυστηρά οι διαστάσεις αναφοράς που υποδεικνύονται στο σχήμα.

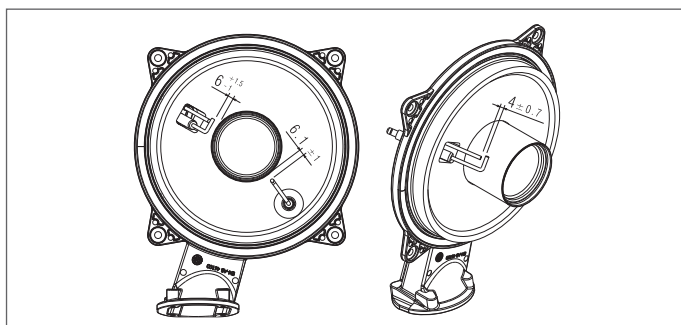

⊘ Μην τρίβετε τα ηλεκτρόδια. Εάν τα ηλεκτρόδια πρέπει να καθαριστούν, ξεσκονίστε τα χρησιμοποιώντας μια βούρτσα με μαλακές τρίχες.

⚠ Σε περίπτωση παραμόρφωσης και φθοράς των ηλεκτροδίων εκτός των ανοχών, αντικαταστήστε τα.

Για να σφίξετε τις βίδες, εφαρμόστε ροπή 2,3 Nm.

⚠ Προκειμένου να αποφευχθούν πιθανές ανωμαλίες λειτουργίας, τα ηλεκτρόδια του αισθητήρα ανάφλεξης και ανίχνευσης/ιονισμού πρέπει να αντικαθίστανται κάθε 5 χρόνια.

⚠ Εκτελέστε μια νέα διαδικασία "GAR", στη συνέχεια αφαιρέστε την τροφοδοσία για τουλάχιστον 10 δευτερόλεπτα και τέλος εκτελέστε μια νέα διαδικασία "GAC" (βλ. παρ. 5.4).

Αντικατάσταση πλακέτας

- Το συμβούλιο ελέγχου και ρύθμισης δεν προβλέπει συγκεκριμένη διαδικασία για την επαλήθευση της φθοράς του. Σε περίπτωση αντικατάστασης, ανατρέξτε στην παράγραφο «5.17 Αντικατάσταση πλακέτας».

Αντικατάσταση πλακέτας διασύνδεσης

- Η πλακέτα διασύνδεσης δεν παρέχει συγκεκριμένη διαδικασία για την επαλήθευση της φθοράς της. Σε περίπτωση αντικατάστασης, ανατρέξτε στην παράγραφο «5.16 Αντικατάσταση διεπαφής».

Αντικατάσταση βαλβίδας αερίου

- Η βαλβίδα αερίου δεν παρέχει συγκεκριμένη διαδικασία για την επαλήθευση της φθοράς της. Σε περίπτωση αντικατάστασης, ανατρέξτε στην παράγραφο «5.15 Αντικατάσταση βαλβίδας αερίου (P205)».
- Η βαλβίδα αερίου δεν παρέχει συγκεκριμένη διαδικασία καθαρισμού.

6.1 Προγραμματιζόμενες παράμετροι

Ακολουθεί ο κατάλογος των προγραμματιζόμενων παραμέτρων: ΧΡΗΣΤΗΣ (πάντα διαθέσιμος) και ΥΠΕΥΘΥΝΟΣ ΕΓΚΑΤΑΣΤΑΣΗΣ (πρόσβαση με κωδικό πρόσβασης 18): ορίστε τον κωδικό πρόσβασης σύμφωνα με τη διαδικασία που αναφέρεται στο κεφάλαιο 10 «Ρύθμιση κωδικού πρόσβασης, πρόσβαση και τροποποίηση παραμέτρων».

Για λεπτομερή επεξήγηση των παραμέτρων, ανατρέξτε στην παράγραφο «6.2 Περιγραφή παραμέτρων».

 Ορισμένες από τις πληροφορίες ενδέχεται να μην είναι διαθέσιμες ανάλογα με το επίπεδο πρόσβασης, την κατάσταση του μηχανήματος ή τη διαμόρφωση του συστήματος.

		ΠΟΙΕΣ ΠΑΡΑΜΕΤΡΟΙ ΕΙΝΑΙ ΟΡΑΤΕΣ/ΠΡΟΣΒΑΣΙΜΕΣ		
		ΧΡΗΣΤΗΣ	ΥΠΕΥΘΥΝΟΣ ΕΓΚΑΤΑΣΤΑΣΗΣ	ΣΕΡΒΙΣ
ΕΠΙΠΕΔΟ ΚΩΔΙΚΟΣ ΠΡΟΣΒΑΣΗΣ	ΧΡΗΣΤΗΣ (πάντα διαθέσιμος)	X		
	ΥΠΕΥΘΥΝΟΣ ΕΓΚΑΤΑΣΤΑΣΗΣ (κωδ. πρόσβασης 18)	X	X	
	ΣΕΡΒΙΣ	X	X	X

ΠΑΡΑΜΕΤΡΟΙ ΧΡΗΣΤΗ 		Τιμή		Επίπεδο κωδικού πρόσβασης	Εργοστασιακή τιμή	Προσαρμοσμένες τιμές
		Min	Max			
ΜΕΝΟΥ	ΠΑΡΑΜΕΤΡΟΣ					
P1	ΡΥΘΜΙΣΕΙΣ					
	P101	ΓΛΩΣΣΕΣ	0 0: IT • 1: RO • 2: FR • 3: EN • 4: SR • 5: HR • 6: ES • 7: GR • 8: BG • 9: PL • 10: SL	10	ΧΡΗΣΤΗΣ	0
	P102	ΩΡΑ ΚΑΙ ΗΜΕΡΟΜΗΝΙΑ			ΧΡΗΣΤΗΣ	
	P103	ΠΡΟΓΡΑΜΜΑΤΙΣΜΟΣ ΩΡΑΣ			ΧΡΗΣΤΗΣ	
	P104	ΜΟΝΑΔΕΣ	0 (μετρικό σύστημα)	1 (αγγλικό σύστημα)	ΧΡΗΣΤΗΣ	0
	P105	ΚΥΛΙΣΗ	0 (καθιστώ ανάκατο)	1 (επιτρέπω)	ΧΡΗΣΤΗΣ	0
	P106	BUZZER	0	1	ΧΡΗΣΤΗΣ	1

ΠΑΡΑΜΕΤΡΟΙ ΕΓΚΑΤΑΣΤΑΤΗ		Τιμή		Επίπεδο κωδικού πρόσβασης	Εργοστασιακή τιμή	Προσαρμοσμένες τιμές
		Min	Max			
ΜΕΝΟΥ	ΠΑΡΑΜΕΤΡΟΣ					
P2	ΚΑΥΣΗ					
	P201	GAS - ΤΥΠΟΣ ΑΕΡΙΟΥ	1	4	ΥΠΕΥΘΥΝΟΣ ΕΓΚΑΤΑΣΤΑΣΗΣ	1
	P205	d52 - P1 ΒΑΛΒΙΔΑ ΑΕΡΙΟ	20	70	ΥΠΕΥΘΥΝΟΣ ΕΓΚΑΤΑΣΤΑΣΗΣ εάν ο λέβητας είναι απενεργοποιημένος	45
	P206	GAC - ΡΥΘΜΙΣΗ ΒΑΛΒΙΔΑΣ	0	1	ΥΠΕΥΘΥΝΟΣ ΕΓΚΑΤΑΣΤΑΣΗΣ μόνο αν υπάρχει φλόγα	0
	P208	APL - ΙΣΧΥΣ	0	1	ΥΠΕΥΘΥΝΟΣ ΕΓΚΑΤΑΣΤΑΣΗΣ	0: 25 BIS 1: 35 BIS
P3	ΔΙΑΜΟΡΦΩΣΗ					
	P301	ΥΔΡΑΥΛΙΚΗ ΔΙΑΜΟΡΦΩΣΗ	0	4	ΥΠΕΥΘΥΝΟΣ ΕΓΚΑΤΑΣΤΑΣΗΣ	2*
	P306	ΕΛΑΧΙΣΤΗ ΤΑΧΥΤΗΤΑ ΑΝΕΜΙΣΤΗΡΑ	1.000 στροφές ανά λεπτό	3.600 στροφές ανά λεπτό	ΥΠΕΥΘΥΝΟΣ ΕΓΚΑΤΑΣΤΑΣΗΣ	βλέπε πίνακα τεχνικών δεδομένων
	P307	ΜΕΓΙΣΤΗ ΤΑΧΥΤΗΤΑ ΑΝΕΜΙΣΤΗΡΑ	3.700 στροφές ανά λεπτό	10.000 στροφές ανά λεπτό	ΥΠΕΥΘΥΝΟΣ ΕΓΚΑΤΑΣΤΑΣΗΣ	βλέπε πίνακα τεχνικών δεδομένων
	P309	ΜΕΓΙΣΤΗ ΤΑΧΥΤΗΤΑ ΑΝΕΜΙΣΤΗΡΑ CH	P306 (ΕΛΑΧΙΣΤΗ ΤΑΧΥΤΗΤΑ ΑΝΕΜΙΣΤΗΡΑ)	P307 (ΜΕΓΙΣΤΗ ΤΑΧΥΤΗΤΑ ΑΝΕΜΙΣΤΗΡΑ)	ΥΠΕΥΘΥΝΟΣ ΕΓΚΑΤΑΣΤΑΣΗΣ	βλέπε πίνακα τεχνικών δεδομένων
	P310	RANGE RATED	ΜΗΝ ΤΗΝ ΤΡΟΠΟΠΟΙΕΙΤΕ			
	P311	ΕΞΟΔΟΣ ΑΥΧ1	0	2	ΥΠΕΥΘΥΝΟΣ ΕΓΚΑΤΑΣΤΑΣΗΣ	0
	P312	ΕΠΑΝΑΤΑΞΗ ΑΙΣΘΗΤΗΡΙΟΥ ΚΑΥΣΑΕΡΙΩΝ	0	1	ΥΠΕΥΘΥΝΟΣ ΕΓΚΑΤΑΣΤΑΣΗΣ	0
P4	ΘΕΡΜΑΝΣΗ					
	P405	ΕΛΕΓΧΟΣ ΚΥΚΛΟΦΟΡΗΤΗ	41	100	ΥΠΕΥΘΥΝΟΣ ΕΓΚΑΤΑΣΤΑΣΗΣ	85
	P408	ID14_ΙΣΧΥΣ_ΣΥΣΤΟΙΧΙΑΣ	ΔΕΝ ΧΡΗΣΙΜΟΠΟΙΕΙΤΑΙ ΣΕ ΑΥΤΟ ΤΟ ΜΟΝΤΕΛΟ			
	P409	ΕΝΔΟΔΑΠΕΔΙΑ ΘΕΡΜΑΝΣΗ	0	1	ΥΠΕΥΘΥΝΟΣ ΕΓΚΑΤΑΣΤΑΣΗΣ εάν ο λέβητας βρίσκεται στο OFF και σε εγκαταστάσεις BT	0
	P410	ΑΠΕΝΕΡΓΟΠΟΙΗΣΗ ΘΕΡΜΑΝΣΗΣ	0 min	30 min	ΥΠΕΥΘΥΝΟΣ ΕΓΚΑΤΑΣΤΑΣΗΣ	3 min
	P411	ΕΠΑΝΑΤΑΞΗ ΧΡΟΝΟΔΙΑΚΟΠΤΩΝ ΘΕΡΜΑΝΣΗΣ	0	1	ΥΠΕΥΘΥΝΟΣ ΕΓΚΑΤΑΣΤΑΣΗΣ	0
	P415	ΤΥΠΟΣ ΚΥΡΙΑΣ ΖΩΝΗΣ	0	1	ΥΠΕΥΘΥΝΟΣ ΕΓΚΑΤΑΣΤΑΣΗΣ	0
	P416	ΡΥΘΜΙΣΗ ΜΕΓΙΣΤΗΣ ΘΕΡΜΟΚΡΑΣΙΑΣ ΘΕΡΜΑΝΣΗΣ	ΡΥΘΜΙΣΗ ΕΛΑΧΙΣΤΗΣ ΘΕΡΜΟΚΡΑΣΙΑΣ ΘΕΡΜΑΝΣΗΣ	ΑΤ: 80°C - ΒΤ: 45°C	ΥΠΕΥΘΥΝΟΣ ΕΓΚΑΤΑΣΤΑΣΗΣ	ΑΤ: 80°C - ΒΤ: 45°C
	P417	ΡΥΘΜΙΣΗ ΕΛΑΧΙΣΤΗΣ ΘΕΡΜΟΚΡΑΣΙΑΣ ΘΕΡΜΑΝΣΗΣ	20°C	ΡΥΘΜΙΣΗ ΜΕΓΙΣΤΗΣ ΘΕΡΜΟΚΡΑΣΙΑΣ ΘΕΡΜΑΝΣΗΣ	ΥΠΕΥΘΥΝΟΣ ΕΓΚΑΤΑΣΤΑΣΗΣ	ΑΤ: 40°C - ΒΤ: 20°C
	P418	ΘΕΡΜΟΡΥΘΜΙΣΗ ΚΥΡΙΑΣ ΖΩΝΗΣ	0	1	ΥΠΕΥΘΥΝΟΣ ΕΓΚΑΤΑΣΤΑΣΗΣ εάν υπάρχει εξωτερικός αισθητήρας	0
	P419	ΚΑΜΠΥΛΕΣ ΚΥΡΙΑΣ ΖΩΝΗΣ	ΑΤ: 1,0 - ΒΤ: 0,2	ΑΤ: 3,0 - ΒΤ: 0,8	ΥΠΕΥΘΥΝΟΣ ΕΓΚΑΤΑΣΤΑΣΗΣ	ΑΤ 2,0 - ΒΤ 0,5
	P420	ΝΥΚΤΕΡΙΝΗ ΑΝΤΙΣΤΑΘΜΙΣΗ Κ.Ζ.	0	1	ΥΠΕΥΘΥΝΟΣ ΕΓΚΑΤΑΣΤΑΣΗΣ μόνο αν P418 = 1	0
	P421	ΧΡΟΝΙΚΟΣ ΠΡΟΓΡΑΜΜΑΤΙΣΜΟΣ	0	1		0
	P422	ΧΕΙΡΟΚΙΝΗΤΗ ΕΝΕΡΓΟΠΟΙΗΣΗ ΛΕΙΤΟΥΡΓΙΑΣ ΑΥΤΟ	0	1		0
	P433	ΤΥΠΟΣ ΚΤΙΡΙΟΥ	5	20	ΥΠΕΥΘΥΝΟΣ ΕΓΚΑΤΑΣΤΑΣΗΣ	5
	P434	ΕΠΙΔΡΑΣΗ ΕΞΩΤ.ΑΙΘ.	0	255	ΥΠΕΥΘΥΝΟΣ ΕΓΚΑΤΑΣΤΑΣΗΣ μόνο αν P418 = 1	20

*P301: 0 = ΜΟΝΟ ΘΕΡΜΑΝΣΗ - 1 = ΣΤΙΓΜΙΑΙΑ ΜΕ ΔΙΑΚΟΠΤΗ ΡΟΗΣ - 2 = ΣΤΙΓΜΙΑΙΑ ΜΕ ΜΕΤΡΗΤΗ ΡΟΗΣ - 3 = ΜΠΟΪΛΕΡ ΜΕ ΑΙΣΘΗΤΗΡΑ - 4 = ΜΠΟΪΛΕΡ ΜΕ ΘΕΡΜΟΣΤΑΤΗ

Όταν ο λέβητας συνδυάζεται με το σετ DOSSERET (αξεσουάρ που διατίθεται κατόπιν αιτήματος), οι παράμετροι για τη χρήση του σετ πρέπει να προγραμματιστούν ΠΡΙΝ από τη χρήση του λέβητα

ΠΑΡΑΜΕΤΡΟΙ ΕΓΚΑΤΑΣΤΑΤΗ		Τιμή		Επίπεδο κωδικού πρόσβασης	Εργοστασιακή τιμή	Προσαρ-μοσμένες τιμές
		Min	Max			
AT = ΥΨΗΛΗ ΘΕΡΜΟΚΡΑΣΙΑ BT = ΧΑΜΗΛΗ ΘΕΡΜΟΚΡΑΣΙΑ						
P5	ZNX					
	P508	ΡΥΘΜΙΣΗ ΕΛΑΧΙΣΤΗΣ ΘΕΡΜ. ΖΝΧ	37°C	49°C	ΥΠΕΥΘΥΝΟΣ ΕΓΚΑΤΑΣΤΑΣΗΣ	37°C
	P509	ΡΥΘΜΙΣΗ ΜΕΓΙΣΤΗΣ ΘΕΡΜ. ΖΝΧ	49°C	60°C	ΥΠΕΥΘΥΝΟΣ ΕΓΚΑΤΑΣΤΑΣΗΣ	60°C
	P511	ΕΝΕΡΓΟΠΟΙΗΣΗ ΗΛΙΑΚΟΥ ΣΥΣΤΗΜΑΤΟΣ (SUN ON)	0	5	ΥΠΕΥΘΥΝΟΣ ΕΓΚΑΤΑΣΤΑΣΗΣ	0
	P520	ΕΝΕΡΓΟΠΟΙΗΣΗ ΣΑΚΙΔΙΟΥ	0 (ανάπηρος)	1 (ενεργοποιημένη)	ΥΠΕΥΘΥΝΟΣ ΕΓΚΑΤΑΣΤΑΣΗΣ	0
	P521	ΛΕΙΤΟΥΡΓΙΑ STAND	0 ECO	1 COMFORT	ΥΠΕΥΘΥΝΟΣ ΕΓΚΑΤΑΣΤΑΣΗΣ	1

ΠΑΡΑΜΕΤΡΟΙ ΣΕΡΒΙΣ		Τιμή		Επίπεδο κωδικού πρόσβασης	Εργοστασιακή τιμή	Προσαρ-μοσμένες τιμές
		Min	Max			
ΜΕΝΟΥ	ΠΑΡΑΜΕΤΡΟΣ					
P3	ΔΙΑΜΟΡΦΩΣΗ					
	P302	ΜΕΤΑΤΡΟΠΕΑΣ ΠΙΕΣΗΣ ΝΕΡΟΥ	0	1	ΣΕΡΒΙΣ	1
	P303	ΕΝΕΡΓΟΠΟΙΗΣΗ ΑΥΤΟΜΑΤΗΣ ΠΛΗΡΩΣΗΣ ΝΕΡΟΥ	0	1	ΣΕΡΒΙΣ	0
	P304	ΕΝΑΡΞΗ ΠΛΗΡΩΣΗΣ ΣΥΣΤΗΜΑΤΟΣ	ΔΕΝ ΔΙΑΤΙΘΕΤΑΙ ΣΕ ΑΥΤΟ ΤΟ ΜΟΝΤΕΛΟ			
	P305	ΚΥΚΛΟΣ ΕΞΑΕΡΩΣΗΣ	0	1	ΣΕΡΒΙΣ	1
P4	ΘΕΡΜΑΝΣΗ					
	P401	ΥΣΤΕΡΗΣΗ OFF ΥΨΗΛΗ ΘΕΡΜΟΚΡΑΣΙΑ	2°C	10°C	ΣΕΡΒΙΣ	5°C
	P402	ΥΣΤΕΡΗΣΗ ON ΥΨΗΛΗ ΘΕΡΜΟΚΡΑΣΙΑ	2°C	10°C	ΣΕΡΒΙΣ	5°C
	P403	ΥΣΤΕΡΗΣΗ OFF ΧΑΜΗΛΗ ΘΕΡΜΟΚΡΑΣΙΑ	2°C	10°C	ΣΕΡΒΙΣ	3°C
	P404	ΥΣΤΕΡΗΣΗ ON ΧΑΜΗΛΗ ΘΕΡΜΟΚΡΑΣΙΑ	2°C	10°C	ΣΕΡΒΙΣ	3°C
P5	ZNX					
	P510	ΚΑΘΥΣΤΕΡΗΣΗ ΖΝΧ	0 δευτ.	60 δευτ.	ΣΕΡΒΙΣ	0 δευτ.
	P512	CH DELAY ΜΕΤΑ ΛΕΙΤ.ΖΝΧ	0	1	ΣΕΡΒΙΣ	0
	P513	ΧΡ.ΚΑΘΥΣΤ. ΛΕΙΤ.ΘΕΡΜ.	1 δευτ.	255 δευτ.	ΣΕΡΒΙΣ	6 δευτ.
P7	ΣΥΝΤΗΡΗΣΗ					
	P701	ΕΝΕΡΓΟΠΟΙΗΣΗ ΙΣΤΟΡΙΚΟΥ ΣΦΑΛΜΑΤΩΝ	0	1	ΣΕΡΒΙΣ	0 (η τιμή αλλάζει αυτόματα στο 1 μετά από 2 ώρες λειτουργίας)
	P706	ΛΕΙΤΟΥΡΓΙΑΣ ΕΙΔΟΠΟΙΗΣΗΣ ΣΥΝΤΗΡΗΣΗΣ	0	2	ΣΕΡΒΙΣ	2
	P707	ΛΗΞΗ	0	255	ΣΕΡΒΙΣ	52
	P708	ΥΨΗΛΗΣ ΑΠΟΔΟΣΗ ΕΝΕΡΓΟΠΟΙΗΜΕΝΗ	0	1	ΣΕΡΒΙΣ	0
P8	ΣΥΝΔΕΣΙΜΟΤΗΤΑ					
	P801	ΔΙΑΜΟΡΦΩΣΗ BUS 485	0	2	ΣΕΡΒΙΣ	0
	P803	ΔΙΑΜΟΡΦΩΣΗ OTBUS	0	1	ΣΕΡΒΙΣ	1

Ο λέβητας με DOSSERET δεν επιτρέπει τη χρήση της συσκευής T300 η παράμετρος 801 πρέπει να οριστεί στο 0.

6.2 Περιγραφή παραμέτρων

Ορισμένες από τις ακόλουθες λειτουργίες ενδέχεται να μην είναι διαθέσιμες ανάλογα με τον τύπο του μηχανήματος και το επίπεδο πρόσβασης.

ΠΑΡΑΜΕΤΡΟΣ	ΠΕΡΙΓΡΑΦΗ
P1 - ΡΥΘΜΙΣΕΙΣ	P101 Για να ρυθμίσετε την επιθυμητή γλώσσα: 0: IT • 1: RO • 2: FR • 3: EN • 4: SR • 5: HR • 6: ES • 7: GR • 8: BG • 9: PL • 10: SL
	P102 Για να ρυθμίσετε ΩΡΑ ΚΑΙ ΗΜΕΡΑ
	P103 Για να ρυθμίσετε τον ΩΡΙΑΙΟ ΠΡΟΓΡΑΜΜΑΤΙΣΜΟ
	P104 Για να αλλάξετε τη μονάδα μέτρησης: 0 = μονάδα μέτρησης ΜΕΤΡΙΚΟΥ ΣΥΣΤΗΜΑΤΟΣ / 1 = μονάδα μέτρησης ΑΓΓΛΙΚΟΥ ΣΥΣΤΗΜΑΤΟΣ. Οι αριθμοί εκφράζονται σε δεκαδική μορφή (ένας αριθμός) για τιμές μεταξύ -9°C και +99°C, εκφράζονται σε ακέραια μορφή για τιμές ≤ -10°C και ≥ 100°C, ενώ η απεικόνιση σε °F (Fahrenheit) θα εκφράζεται πάντα σε ακέραια μορφή.
	P105 Για να ρυθμίσετε το κυλιόμενο κείμενο: 0 = καθιστώ ανίκανο / 1 = επιτρέπω
	P106 Για να ενεργοποιήσετε/απενεργοποιήσετε το ηχητικό σήμα: 0 = βομβητής OFF / 1 = βομβητής ON
P2 - ΚΑΥΣΗ	P201 Αυτή η παράμετρος προσδιορίζει τον τύπο αερίου: 1=ΜΕΘΑΝΙΟ • 2=ΥΓΡΑΕΡΙΟ • 3=ΥΓΡΟΠΟΙΗΜΕΝΟ ΦΥΣΙΚΟ ΑΕΡΙΟ • 4=ΜΕΙΓΜΑ ΑΕΡΑ-ΠΡΟΠΑΝΙΟΥ (G230).
	P208 Αυτή η παράμετρος χρησιμοποιείται για τη ρύθμιση της ισχύος του λέβητα: 0 - 1. Για λεπτομέρειες, δείτε την ενότητα «Προγραμματιζόμενες παράμετροι».
	P205 Αυτή η παράμετρος χρησιμοποιείται για την εκ νέου ρύθμιση της τιμής P1 της βαλβίδας αερίου
	P206 Αυτή η παράμετρος χρησιμοποιείται για τη βαθμονόμηση της βαλβίδας αερίου και του συστήματος ελέγχου καύσης
P3 - ΔΙΑΜΟΡΦΩΣΗ	P301 Για να ορίσετε τον τύπο υδραυλικής διαμόρφωσης του λέβητα: 0 = ΜΟΝΟ ΘΕΡΜΑΝΣΗ - 1 = ΣΤΙΓΜΙΑΙΑ ΜΕ ΔΙΑΚΟΠΤΗ ΡΟΗΣ - 2 = ΣΤΙΓΜΙΑΙΑ ΜΕ ΜΕΤΡΗΤΗ ΡΟΗΣ - 3 = ΜΠΟΙΛΕΡ ΜΕ ΑΙΣΘΗΤΗΡΑ - 4 = ΜΠΟΙΛΕΡ ΜΕ ΘΕΡΜΟΣΤΑΤΗ Εργοστασιακή τιμή = 2, μην την τροποποιείτε. Σε περίπτωση αντικατάστασης της ηλεκτρονικής πλακέτας, βεβαιωθείτε ότι αυτή η παράμετρος έχει ρυθμιστεί στο 2
	P302 Για να ορίσετε τον τύπο μετατροπέα πίεσης νερού: 0 = πιεσοστάτης νερού - 1 = μετατροπέας πίεσης Εργοστασιακή τιμή = 1, μην την τροποποιείτε. Σε περίπτωση αντικατάστασης της ηλεκτρονικής κάρτας, βεβαιωθείτε ότι αυτή η παράμετρος έχει ρυθμιστεί στο 1.
	P303 Για να ενεργοποιήσετε τη λειτουργία «ημιαυτόματης πλήρωσης» όταν στον λέβητα είναι εγκατεστημένος ένας μετατροπέας πίεσης και μια ηλεκτροβαλβίδα πλήρωσης. Εργοστασιακή τιμή = 0, μην την τροποποιείτε. Σε περίπτωση αντικατάστασης της ηλεκτρονικής κάρτας, βεβαιωθείτε ότι αυτή η παράμετρος έχει ρυθμιστεί στο 0.
	P304 Εμφανίζεται μόνο αν P303 = 1. ΔΕΝ ΔΙΑΤΙΘΕΤΑΙ ΣΕ ΑΥΤΟ ΤΟ ΜΟΝΤΕΛΟ.
	P305 Για να απενεργοποιήσετε τη λειτουργία του κύκλου εξάερωσης. Εργοστασιακή τιμή = 1, ορίστε την παράμετρο στο 0 για να απενεργοποιήσετε τη λειτουργία.
	P306 Για να αλλάξετε τον ελάχιστο αριθμό στροφών του ανεμιστήρα.
	P307 Για να αλλάξετε τον μέγιστο αριθμό στροφών του ανεμιστήρα.
	P309 Για να αλλάξετε τον μέγιστο αριθμό στροφών του ανεμιστήρα κατά τη θέρμανση (μπορεί να προγραμματιστεί εντός του εύρους P306 - P307).
	P310 Ρύθμιση RANGE RATED. ΜΗΝ ΤΗΝ ΤΡΟΠΟΠΟΙΕΙΤΕ.
	P311 Για να ρυθμίσετε τη λειτουργία ενός πρόσθετου relé [μόνο αν έχει εγκατασταθεί η κάρτα BE09 (κι αξεσουάρ)] για να μεταφέρει μια φάση (230Vac) σε μια δεύτερη αντλία θέρμανσης (πρόσθετη αντλία) ή σε μια βαλβίδα ζώνης. Εργοστασιακή τιμή = 0 και μπορεί να προγραμματιστεί εντός του εύρους 0 - 2 με την ακόλουθη σημασία: P311= 0 - η διαχείριση εξαρτάται από τη διαμόρφωση της καλωδίωσης της κάρτας BE09: κομμένος βραχυκυκλωτήρας: πρόσθετη αντλία - βραχυκυκλωτήρας που υπάρχει: βαλβίδα ζώνης. P311= 1 - διαχείριση βαλβίδων ζώνης P311= 2 - διαχείριση της συμπληρωματικής αντλίας
	P312 Επιτρέπει τον μηδενισμό του μετρητή ωρών λειτουργίας υπό ορισμένες συνθήκες (βλ. "Ενδείξεις και ανωμαλίες" για περισσότερες λεπτομέρειες, βλ. βλάβη E091). Εργοστασιακή τιμή = 0, ορίστε στο 1 για να μηδενιστεί ο μετρητής ωρών του αισθητήρα καπνών μετά από επέμβαση καθαρισμού του πρωτεύοντος εναλλάκτη θερμότητας. Μόλις ολοκληρωθεί η διαδικασία μηδενισμού, η παράμετρος επιστρέφει αυτόματα στην τιμή 0.

P4 - ΘΕΡΜΑΝΣΗ	P401	Για εγκαταστάσεις σε υψηλή θερμοκρασία, αυτή η παράμετρος σας επιτρέπει να ορίσετε την τιμή υστέρησης που χρησιμοποιείται από την κάρτα ρύθμισης για τον υπολογισμό της θερμοκρασίας παροχής για την απενεργοποίηση του καυστήρα: ΘΕΡΜΟΚΡΑΣΙΑ ΑΠΕΝΕΡΓΟΠΟΙΗΣΗΣ = ΤΙΜΗ ΡΥΘΜΙΣΗΣ ΤΗΣ ΘΕΡΜΑΝΣΗΣ + P401. Εργοστασιακή τιμή = 5°C, μπορεί να αλλάξει στο εύρος 2 - 10°C.
	P402	Για εγκαταστάσεις σε υψηλή θερμοκρασία, αυτή η παράμετρος σας επιτρέπει να ορίσετε την τιμή υστέρησης που χρησιμοποιείται από την κάρτα ρύθμισης για τον υπολογισμό της θερμοκρασίας παροχής για την έναυση του καυστήρα: ΘΕΡΜΟΚΡΑΣΙΑ ΕΝΑΥΣΗΣ = ΤΙΜΗ ΡΥΘΜΙΣΗΣ ΤΗΣ ΘΕΡΜΑΝΣΗΣ - P402. Εργοστασιακή τιμή = 5°C, μπορεί να αλλάξει στο εύρος 2 - 10°C.
	P403	Για εγκαταστάσεις σε χαμηλή θερμοκρασία, αυτή η παράμετρος σας επιτρέπει να ορίσετε την τιμή υστέρησης που χρησιμοποιείται από την κάρτα ρύθμισης για τον υπολογισμό της θερμοκρασίας παροχής για την απενεργοποίηση του καυστήρα: ΘΕΡΜΟΚΡΑΣΙΑ ΑΠΕΝΕΡΓΟΠΟΙΗΣΗΣ = ΣΗΜΕΙΟ ΡΥΘΜΙΣΗΣ ΤΗΣ ΘΕΡΜΑΝΣΗΣ + P403. Εργοστασιακή τιμή = 3°C, μπορεί να αλλάξει στο εύρος 2°C - 10°C.
	P404	Για εγκαταστάσεις σε χαμηλή θερμοκρασία, αυτή η παράμετρος σας επιτρέπει να ορίσετε την τιμή υστέρησης που χρησιμοποιείται από την κάρτα ρύθμισης για τον υπολογισμό της θερμοκρασίας παροχής για την έναυση του καυστήρα: ΘΕΡΜΟΚΡΑΣΙΑ ΕΝΑΥΣΗΣ = ΣΗΜΕΙΟ ΡΥΘΜΙΣΗΣ ΤΗΣ ΘΕΡΜΑΝΣΗΣ - P404. Εργοστασιακή τιμή = 3°C, μπορεί να αλλάξει στο εύρος 2°C - 10°C.
	P405	Αναλογική αντλία μεταβλητής ταχύτητας.
	P408	Επιτρέπει τη ρύθμιση του λέβητα για εφαρμογές σε σειρά μέσω σήματος OT+. Δεν ισχύει για αυτό το μοντέλο λέβητα.
	P409	Σας επιτρέπει να ενεργοποιήσετε τη λειτουργία θέρμανσης υποστρώματος (ανατρέξτε στην παράγραφο "Λειτουργία θέρμανσης υποστρώματος" για περισσότερες λεπτομέρειες). Εργοστασιακή τιμή = 0, με τον λέβητα σε κατάσταση OFF. Ορίστε στο 1 για να ενεργοποιήσετε τη λειτουργία θέρμανσης υποστρώματος στις ζώνες θέρμανσης σε χαμηλή θερμοκρασία. Η παράμετρος επιστρέφει αυτόματα στην τιμή 0 μόλις ολοκληρωθεί η λειτουργία θέρμανσης υποστρώματος, μπορεί να διακοπεί πρόωρα θέτοντας την τιμή στο 0.
	P410	Επιτρέπει να τροποποιήσετε τον χρονισμό αναγκαστικής απενεργοποίησης της θέρμανσης, ο οποίος σχετίζεται με τον χρόνο καθυστέρησης που εισάγεται για την εκ νέου έναυση του καυστήρα όταν ο καυστήρας απενεργοποιείται λόγω της επίτευξης της θερμοκρασίας θέρμανσης. Εργοστασιακή τιμή = 3 λεπτά και μπορεί να οριστεί σε μια τιμή μεταξύ 0 και 20 λεπτών.
	P411	Σας επιτρέπει να ακυρώσετε τη λειτουργία ΜΗΔΕΝΙΣΜΟΣ ΧΡΟΝΩΝ ΘΕΡΜΑΝΣΗΣ και ΜΕΙΩΜΕΝΟΣ ΧΡΟΝΙΣΜΟΣ ΜΕΓΙΣΤΗΣ ΙΣΧΥΟΣ, κατά την οποία η ταχύτητα του ανεμιστήρα περιορίζεται μεταξύ της ελάχιστης τιμής και του 60% της ρυθμισμένης μέγιστης ισχύος θέρμανσης, με αύξηση 10% κάθε 15 λεπτά. Εργοστασιακή τιμή = 0, ορίστε στο 1 για να μηδενίσετε τους χρονισμούς.
	P415	Σας επιτρέπει να καθορίσετε τον τύπο της ζώνης που θα θερμανθεί, μπορείτε να επιλέξετε από τις ακόλουθες επιλογές: 0 = ΨΥΧΛΗ ΘΕΡΜΟΚΡΑΣΙΑ (εργοστασιακή τιμή) • 1 = ΧΑΜΗΛΗ ΘΕΡΜΟΚΡΑΣΙΑ
	P416	Καθορίζει τη μέγιστη τιμή του σημείου ρύθμισης θέρμανσης που μπορεί να ρυθμιστεί: εύρος 20°C - 80°C, προεπιλεγμένη τιμή 80°C για εγκαταστάσεις σε υψηλή θερμοκρασία • εύρος 20°C - 45°C, προεπιλεγμένη τιμή 45°C για εγκαταστάσεις σε χαμηλή θερμοκρασία. Σημείωση: Η τιμή P416 δεν μπορεί να είναι μικρότερη από την P417.
	P417	Με αυτήν την παράμετρο, είναι δυνατός ο προσδιορισμός της ελάχιστης τιμής του σημείου ρύθμισης θέρμανσης που μπορεί να ρυθμιστεί: εύρος 20°C - 80,5°C, προεπιλεγμένη τιμή 40°C για εγκαταστάσεις σε υψηλή θερμοκρασία • εύρος 20°C - 45°C, προεπιλεγμένη τιμή 20°C για εγκαταστάσεις σε χαμηλή θερμοκρασία. Σημείωση: η τιμή του P417 δεν μπορεί να είναι μεγαλύτερη από την P416.
	P418	Επιτρέπει την ενεργοποίηση της θερμορύθμισης, όταν ένας εξωτερικός αισθητήρας είναι συνδεδεμένος στο σύστημα. Εργοστασιακή τιμή = 0, ο λέβητας λειτουργεί πάντα σε σταθερό σημείο. Με την παράμετρο στο 1 και συνδεδεμένο εξωτερικό αισθητήρα, ο λέβητας λειτουργεί σε θερμορύθμιση. Με τον εξωτερικό αισθητήρα αποσυνδεδεμένο, ο λέβητας λειτουργεί πάντα σε σταθερό σημείο. Ανατρέξτε στην παράγραφο "Ρύθμιση θερμορύθμισης" για περισσότερες πληροφορίες σχετικά με αυτήν τη λειτουργία.
	P419	Επιτρέπει να ορίσετε τον αριθμό της καμπύλης αντιστάθμισης που χρησιμοποιείται από τον λέβητα όταν βρίσκεται σε θερμορύθμιση. Εργοστασιακή τιμή = 2,0 για εγκαταστάσεις σε υψηλή θερμοκρασία και 0,5 για εγκαταστάσεις σε χαμηλή θερμοκρασία. Η παράμετρος μπορεί να προγραμματιστεί εντός του εύρους 1,0 - 3,0 για συστήματα σε υψηλή θερμοκρασία και 0,2 - 0,8 για συστήματα σε χαμηλή θερμοκρασία. Ανατρέξτε στην παράγραφο "Ρύθμιση θερμορύθμισης" για περισσότερες λεπτομέρειες σχετικά με αυτήν τη λειτουργία.
P420	Ενεργοποιεί τη λειτουργία «νυχτερινή αντιστάθμιση». Προεπιλεγμένη τιμή = 0, ορίστε την παράμετρο στο 1 για να ενεργοποιήσετε τη λειτουργία. Ανατρέξτε στην παράγραφο "Ρύθμιση θερμορύθμισης" για περισσότερες πληροφορίες σχετικά με αυτήν τη λειτουργία.	
P421	Αυτή η παράμετρος επιτρέπει την ενεργοποίηση του ωριαίου προγραμματισμού της θέρμανσης. Μη ενεργοποιημένος ωριαίος προγραμματισμός = 0 → Όταν η επαφή του θερμοστάτη χώρου κλείνει, το αίτημα θερμότητας ικανοποιείται πάντα χωρίς ωριαίο περιορισμό. Ενεργοποιημένος ωριαίος προγραμματισμός = 1 → Όταν η επαφή του θερμοστάτη χώρου κλείνει, ενεργοποιείται το αίτημα θερμότητας σύμφωνα με τον καθορισμένο ωριαίο προγραμματισμό.	
P422	Αυτή η παράμετρος χρησιμοποιείται για τον καθορισμό του τρόπου μετάβασης από τη μη αυτόματη στην αυτόματη λειτουργία θέρμανσης. Προεπιλεγμένη τιμή = 0: η μετάβαση από τον μη αυτόματο στον αυτόματο ωριαίο προγραμματισμό πρέπει να γίνεται από τον χρήστη με το πάτημα των κουμπιών C+D. Ρυθμίστε στο 1 για να ενεργοποιήσετε τη λειτουργία: η μετάβαση από τον μη αυτόματο στον αυτόματο ωριαίο προγραμματισμό πραγματοποιείται αυτόματα κατά την πρώτη αλλαγή ζώνης.	
P433	Συχνότητα με την οποία ενημερώνεται η τιμή της εξωτερικής θερμοκρασίας που υπολογίζεται για τη θερμορύθμιση. Για κτίρια με κακή μόνωση, θα χρησιμοποιείται μια χαμηλή τιμή για αυτήν την τιμή.	
P434	Διάστημα ανάγνωσης της τιμής της εξωτερικής θερμοκρασίας που διαβάζεται από τον αισθητήρα.	
P5 - ΖΝΧ	P501-P507	Λειτουργίες που σχετίζονται με τη διαθεσιμότητα μπόιλερ. ΔΕΝ ΔΙΑΤΙΘΕΝΤΑΙ ΣΕ ΑΥΤΟ ΤΟ ΜΟΝΤΕΛΟ.
	P508	Για να ρυθμίσετε το ελάχιστο σημείο ρύθμισης του ζεστού νερού χρήσης.
	P509	Για να ρυθμίσετε το μέγιστο σημείο ρύθμισης του ζεστού νερού χρήσης.
	P510	Ορατό μόνο όταν η παράμετρος P511 = 2 ή 5. Εισάγεται μια καθυστέρηση δευτερολέπτων για την ενεργοποίηση της αντλίας και του ανεμιστήρα σε περίπτωση αιτήματος θερμότητας ζεστού νερού χρήσης.
	P511	Ενεργοποίηση ειδικών λειτουργιών ζεστού νερού χρήσης: 0 = καμία λειτουργία - 1 = εισαγωγή καθυστέρησης εκκίνησης του διακόπτη ροής/μετρητή ροής - 2 = σε περίπτωση απενεργοποίησης λόγω υπερβολικής θερμοκρασίας στο ζεστό νερό χρήσης (με λήψη σε εξέλιξη), ο ανεμιστήρας διατηρείται στην ελάχιστη ταχύτητα για να μειωθεί ο χρόνος αναμονής για επανεκκίνηση - 3 = απόλυτοι θερμοστάτες ζεστού νερού χρήσης - 4 = έξυπνη λειτουργία ζεστού νερού χρήσης έναντι ταλαντώσεων - 5 = όλες οι προηγούμενες λειτουργίες είναι ενεργές.
	P512	Μέσω αυτής της τιμής μπορείτε να ενεργοποιήσετε/απενεργοποιήσετε τη λειτουργία μετακυκλοφορίας του ζεστού νερού χρήσης με αναστολή της έναρξης θέρμανσης.
	P513	Μέσω αυτής της τιμής μπορείτε να ρυθμίσετε τη διάρκεια της μετακυκλοφορίας του ζεστού νερού χρήσης, όταν είναι ενεργοποιημένη η λειτουργία μετακυκλοφορίας ζεστού νερού χρήσης με αναστολή της έναρξης θέρμανσης.
	P520	Για να καταστεί δυνατή η λειτουργία του λέβητα σε συνδυασμό με το dossieret.
P521	Η επιλογή COMFORT έχει ως αποτέλεσμα ο λέβητας να έχει όλο και πιο συχνά κύκλους επαναφοράς των μπόιλερ (TANK). Συνιστάται σε οικιακές εφαρμογές όπου οι κύκλοι απόσυρσης είναι συχνοί ή όπου το ζήτημα για όγκο νερού είναι υψηλότερο. Η επιλογή ECO έχει ως αποτέλεσμα ο λέβητας να έχει μειωμένο αριθμό κύκλων επαναφοράς των μπόιλερ (TANK). Επιλογή για περριτώσεις όπου δίνεται μεγαλύτερη βαρύτητα στην εξοικονόμηση ενέργειας.	
P7 - ΣΥΝΤΗΡΗΣΗ	P701	Για να ενεργοποιήσετε την αποθήκευση ιστορικού συναγεμιών. Προεπιλεγμένη τιμή 0, η τιμή αλλάζει αυτόματα στο 1 μετά από 2 ώρες λειτουργίας. Η ρύθμιση της παραμέτρου στην τιμή 0 επαναφέρει το ιστορικό συναγεμιών 1039...1043.
	P706	Αυτή η παράμετρος επιτρέπει τον περιοδικό έλεγχο του λέβητα σύμφωνα με μια περίοδο λειτουργίας που έχει προκαθοριστεί στην παράμετρο P707. Είναι διαθέσιμες τρεις τιμές ρύθμισης: 0 = απενεργοποιημένη λειτουργία 1 = ενεργοποιημένη λειτουργία σύμφωνα με τον ακόλουθο κανόνα: εάν P707 < 4, η οθόνη εμφανίζει τη σήμανση CFS εάν P707 = 0, η οθόνη εμφανίζει τη σήμανση SFS (STOP FOR SERVICE) που υποδεικνύει τη μόνιμη αναστολή όλων των αιτημάτων θερμότητας θέρμανσης και θέρμανσης ζεστού νερού χρήσης. Με δυνατότητα reset 2 = ενεργοποιημένη λειτουργία: εάν P707 = 0, στην οθόνη εμφανίζεται η σήμανση CFS χωρίς καμία διακοπή λειτουργίας. Σε αυτήν την κατάσταση, στο μενού INFO (γραμμή 1044), εμφανίζεται ο αριθμός των ημερών που έχουν παρέλθει από την εμφάνιση της σήμανσης CFS (P707 = 0)  Η σήμανση CFS πραγματοποιείται ανά 10 λεπτά για διάρκεια 1 λεπτού, 1 μήνα πριν από το τέλος της περιόδου που έχει οριστεί στην παράμετρο P707.
	P707	Προκαθορισμένη περίοδος λειτουργίας για κλήση σέρβις (παράμετρος P706)
	P708	Αυτόματη λειτουργία που ενεργοποιείται κατά την πρώτη τροφοδοσία ή μετά από 60 ημέρες μη χρήσης (ηλεκτρικά τροφοδοτούμενος λέβητας). Σε αυτήν τη λειτουργία, ο λέβητας περιορίζει για 60 λεπτά την ισχύ της θέρμανσης στο ελάχιστο και τη μέγιστη θερμοκρασία του ζεστού νερού χρήσης στους 55°C. Η ενεργοποίηση του καθαρισμού καπνοδόχου απενεργοποιεί προσωρινά αυτήν τη λειτουργία. 0 = ΕΡΓΟΣΤΑΣΙΑΚΗ ΤΙΜΗ, απενεργοποιεί τη λειτουργία υψηλής απόδοσης • 1 = ενεργοποιεί τη λειτουργία υψηλής απόδοσης
P8 - ΣΥΝΔΕΣΙΜΟΤΗΤΑ	P801	Αυτή η παράμετρος χρησιμοποιείται για την ενεργοποίηση της απομακρυσμένης διαχείρισης του λέβητα. Είναι διαθέσιμες τρεις τιμές: 0 = ΕΡΓΟΣΤΑΣΙΑΚΗ ΤΙΜΗ. 1 = Διαχείριση ΜΟΝΟ από τη διαπαφή λέβητα. 2 = Διαχείριση από τη διαπαφή λέβητα και τον διαχειριστή συστήματος (T300).
	P803	Αυτή η παράμετρος χρησιμοποιείται για την ενεργοποίηση της απομακρυσμένης του λέβητα μέσω της διάταξης OpenTherm: 0 = Η λειτουργία OT+ είναι απενεργοποιημένη, δεν είναι δυνατός ο τηλεχειρισμός του λέβητα με τη διάταξη OTBus. Με τη ρύθμιση αυτής της παραμέτρου στο 0, οποιαδήποτε σύνδεση OTBus διακόπτεται αμέσως. Το εικονίδιο  και η ένδειξη OTB στην οθόνη απενεργοποιούνται 1 = ΕΡΓΟΣΤΑΣΙΑΚΗ ΤΙΜΗ. Η λειτουργία OT+ είναι ενεργοποιημένη, μπορείτε να συνδέσετε μια συσκευή OTBus για τον τηλεχειρισμό του λέβητα. Κατά τη σύνδεση μιας συσκευής OTBus στον λέβητα, στην οθόνη εμφανίζεται το μήνυμα «OTB» και ανάβει το εικονίδιο  .

Σημείωση: Δεν διασφαλίζεται η πλήρης συμβατότητα με συσκευές OpenTherm τρίτων κατασκευαστών.

Ο λέβητας με DOSSERET δεν επιτρέπει τη χρήση της συσκευής T300 η παράμετρος 801 πρέπει να οριστεί στο 0.

6.3 Μενού INFO

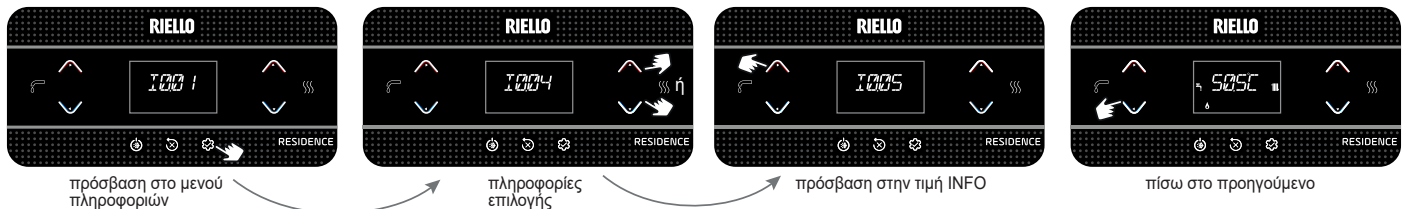







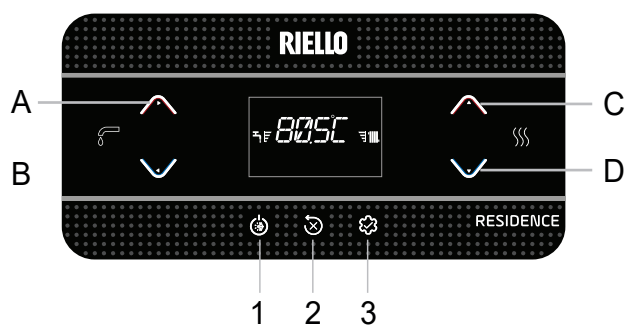

















Εάν δεν πατηθεί κανένα κουμπί, η διεπαφή εξέρχεται αυτόματα από το μενού INFO μετά από 60 δευτερόλεπτα.

ΠΛΗΡΟΦΟΡΙΕΣ ΟΝΟΜΑΤΟΣ		ΠΕΡΙΓΡΑΦΗ
I001	ΩΡΕΣ ΛΕΙΤΟΥΡΓΙΑΣ ΕΝΔΟΔΑΠΕΔΙΑΣ ΘΕΡΜΑΝΣΗΣ	Αριθμός ωρών λειτουργίας θέρμανσης υποστρώματος (όταν λειτουργεί)
I002	ΑΙΣΘΗΤΗΡΙΟ ΘΕΡΜΑΝΣΗΣ	Τιμή αισθητήρα παροχής λέβητα
I003	ΑΙΣΘΗΤΗΡΙΟ ΕΠΙΣΤΡΟΦΗΣ	Τιμή αισθητήρα επιστροφής λέβητα
I004	ΑΙΣΘΗΤΗΡΙΟ ΖΝΧ	Τιμή αισθητήρα ζεστού νερού χρήσης σε περίπτωση στιγμιαίου λέβητα
I005	ΡΥΘΜΙΣΗ ΖΝΧ	Σημείο ρύθμισης ζεστού νερού χρήσης λέβητα ή ΟΤ+ όταν είναι συνδεδεμένος ο χρονοδιακόπτης
I008	ΑΙΣΘΗΤΗΡΙΟ ΚΑΥΣΑΕΡΙΩΝ	Τιμή αισθητήρα καυσαερίων
I009	ΑΙΣΘΗΤΗΡΙΟ ΕΞΩΤΕΡΙΚΗΣ ΘΕΡΜΟΚΡΑΣΙΑΣ	Στιγμιαία τιμή εξωτερικού αισθητήρα
I010	ΕΞΩΤΕΡΙΚΗ ΘΕΡΜΟΚΡΑΣΙΑ ΓΙΑ ΘΕΡΜΟΡΥΘΜΙΣΗ	Φιλτραρισμένη τιμή εξωτερικού αισθητήρα που χρησιμοποιείται στον αλγόριθμο θερμορύθμισης για τον υπολογισμό του σημείου ρύθμισης θέρμανσης
I011	ΜΕΤΡΗΤΗΣ ΡΟΗΣ	Μετρητής ροής
I012	ΤΑΧΥΤΗΤΑ ΑΝΕΜΙΣΤΗΡΑ	Αριθμός στροφών ανεμιστήρα (rpm)
I015	ΩΡΕΣ ΛΕΙΤ. ΑΙΣΘΗΤΗΡΙΟΥ ΚΑΥΣΑΕΡΙΩΝ	Αριθμός ωρών λειτουργίας του εναλλάκτη σε «κατάσταση υγρασίας» (οι τιμές εκφράζονται σε εκατοντάδες ώρες, για παράδειγμα: 01 = 100h)
I016	ΡΥΘΜΙΣΗ ΚΥΡΙΑΣ ΖΩΝΗΣ	Σημείο ρύθμισης παροχής κύριας ζώνης
I017	ΡΥΘΜΙΣΗ ΟΤ ΚΥΡΙΑΣ ΖΩΝΗΣ	Σημείο ρύθμισης παροχής κύριας ζώνης από ΟΤ+
I018	ΠΙΕΣΗ ΝΕΡΟΥ	Πίεση εγκατάστασης
I019	ΩΡΕΣ ΖΝΧ	Ώρες καυστήρα σε λειτουργία ζεστού νερού χρήσης
I020	ΩΡΕΣ ΘΕΡΜΑΝΣΗΣ	Ώρες καυστήρα σε λειτουργία θέρμανσης
I021	ΔΙΑΜΟΡΦΩΣΗ ΖΝΧ	Μέση τιμή ποσοστού διαμόρφωσης με τον καυστήρα σε λειτουργία ζεστού νερού χρήσης
I022	ΘΕΡΜΑΝΣΗ ΖΝΧ	Μέση τιμή ποσοστού διαμόρφωσης με τον καυστήρα σε λειτουργία θέρμανσης
I023	ΑΙΣΘΗΤΗΡΙΟ ΠΡΟΣΑΓΩΓΗΣ ΘΕΡΜΑΝΣΗΣ ΜΕΣΗ ΤΙΜΗ	Μέσες τιμές του αισθητήρα παροχής με τον καυστήρα σε λειτουργία θέρμανσης
I024	ΑΙΣΘΗΤΗΡΙΟ ΠΡΟΣΑΓΩΓΗΣ ΖΝΧ ΜΕΣΗ ΤΙΜΗ	Μέση τιμή αισθητήρα παροχής με τον καυστήρα σε λειτουργία ζεστού νερού χρήσης
I025	ΑΙΣΘΗΤΗΡΙΟ ΕΠΙΣΤΡΟΦΗΣ ΘΕΡΜΑΝΣΗΣ ΜΕΣΗ ΤΙΜΗ	Μέση τιμή του αισθητήρα επιστροφής με τον καυστήρα σε λειτουργία θέρμανσης
I026	ΑΙΣΘΗΤΗΡΙΟ ΕΠΙΣΤΡΟΦΗΣ ΖΝΧ ΜΕΣΗ ΤΙΜΗ	Μέση τιμή αισθητήρα επιστροφής με τον καυστήρα σε λειτουργία ζεστού νερού χρήσης
I027	ΒΑΛΒΙΔΑ ΑΕΡΙΟΥ ΚΥΚΛΟΣ ΛΕΙΤΟΥΡΓΙΑΣ ΟΝ	Αριθμός κύκλων ΟΝ της βαλβίδας αερίου
I029	ΥΨΗΛΗ ΑΠΟΔΟΣΗ	Εάν είναι στο 1, υποδεικνύει την ανάγκη ελέγχου σιφονιού για την πλήρωση
I030	ΑΝΕΣΗ	Άνεση ζεστού νερού χρήσης
I031	ΕΝΕΡΓΟΠΟΙΗΣΗ ΗΛΙΑΚΟΥ ΣΥΣΤΗΜΑΤΟΣ (SUN ON)	Οι ειδικές λειτουργίες είναι ενεργές για υψηλές θερμοκρασίες ζεστού νερού χρήσης εισόδου
I033	ID ΠΙΝΑΚΑ ΕΛΕΓΧΟΥ	Τύπος συνδεδεμένης κάρτας
I034	FMW ΠΙΝΑΚΑ ΕΛΕΓΧΟΥ	Αναθεώρηση προγράμματος λογισμικού της ηλεκτρονικής κάρτας
I035	FMW ΠΙΝΑΚΑ ΕΛΕΓΧΟΥ	Αναθεώρηση προγράμματος λογισμικού διασύνδεσης
I036	ΡΑΔΙΟΣΗΜΑΤΑ	Δείχνει την ποιότητα της σύνδεσης Wi-Fi
I039	ΙΣΤΟΡΙΚΟ ΣΦΑΛΜΑΤΟΣ 1 (παιλιότερο)	Κατάλογος των πέντε τελευταίων καταγεγραμμένων συναγεμμένων
I040	ΙΣΤΟΡΙΚΟ ΣΦΑΛΜΑΤΟΣ 2	
I041	ΙΣΤΟΡΙΚΟ ΣΦΑΛΜΑΤΟΣ 3	
I042	ΙΣΤΟΡΙΚΟ ΣΦΑΛΜΑΤΟΣ 4	
I043	ΙΣΤΟΡΙΚΟ ΣΦΑΛΜΑΤΟΣ 5 (πιο πρόσφατο)	
I044	ΣΥΝΤΗΡΗΣΗ ΕΝΑΛΛΑΚΤΗ	Αριθμός ημερών από τότε που η σήμανση CFS ήταν ενεργή (P707 = 0)
I046	FW ΑΝΑΣΚΟΠΗΣΗ ΑΝΑΠΤΥΞΗΣ ΑΝΕΣΗΣ	FW ΑΝΑΣΚΟΠΗΣΗ ΑΝΑΠΤΥΞΗΣ ΑΝΕΣΗΣ
I047	FW ΑΝΑΘΕΩΡΗΣΗ ΑΣΦΑΛΕΙΑΣ	FW ΑΝΑΘΕΩΡΗΣΗ ΑΣΦΑΛΕΙΑΣ
I048	FW ΑΝΑΣΚΟΠΗΣΗ ΑΝΑΠΤΥΞΗΣ ΑΣΦΑΛΕΙΑΣ	FW ΑΝΑΣΚΟΠΗΣΗ ΑΝΑΠΤΥΞΗΣ ΑΣΦΑΛΕΙΑΣ
I049	FAN FW REVIEW	FAN FW REVIEW

7 ΠΙΝΑΚΑΣ ΕΛΕΓΧΟΥ



A	ΧΡΗΣΙΜΟΠΟΙΕΙΤΑΙ κανονικά για την αύξηση της τιμής της θερμοκρασίας ζεστού νερού χρήσης, όταν όμως επισημαίνεται το βέλος  εκτελείται η λειτουργία επιβεβαίωσης
B	ΧΡΗΣΙΜΟΠΟΙΕΙΤΑΙ κανονικά για τη μείωση της τιμής της θερμοκρασίας ζεστού νερού χρήσης, όταν επισημαίνεται το βέλος  εκτελείται η λειτουργία επιστροφής/ακύρωσης
A+B	Πρόσβαση στις λειτουργίες άνεσης ζεστού νερού χρήσης (βλ «5.6 Λειτουργία «Άνεση ζεστού νερού χρήσης»»)
C+D	Ωριαίος χειροκίνητοπρογραμματισμός θέρμανσης, αλλαγή κατάστασης
C	ΧΡΗΣΙΜΟΠΟΙΕΙΤΑΙ κανονικά για την αύξηση της τιμής της θερμοκρασίας του νερού θέρμανσης, όταν επισημαίνεται το βέλος  σας επιτρέπει να μετακινηθείτε μέσα στο μενού P1
D	ΧΡΗΣΙΜΟΠΟΙΕΙΤΑΙ κανονικά για τη μείωση της τιμής της θερμοκρασίας του νερού θέρμανσης, όταν επισημαίνεται το βέλος  σας επιτρέπει να μετακινηθείτε μέσα στο μενού P1
A+C	Πρόσβαση στο μενού ρύθμισης του ρολογιού (βλ. παράγραφο «8 ΟΔΗΓΙΕΣ ΧΡΗΣΗΣ»)
B+D	Ωριαίος προγραμματισμός
1	Χρησιμοποιείται για την αλλαγή της κατάστασης λειτουργίας του λέβητα (OFF, ΚΑΛΟΚΑΙΡΙ και ΧΕΙΜΩΝΑΣ)
2	Χρησιμοποιείται για τον μηδενισμό της κατάστασης συναγερμού ή τη διακοπή του κύκλου εξαέρωσης
3	Χρησιμοποιείται για πρόσβαση στα μενού INFO (ελαφριά πίεση) και P1 (πίεση > 2 δευτ.). Όταν στην οθόνη εμφανίζεται το εικονίδιο  , το κουμπί αναλαμβάνει τη λειτουργία ENTER και χρησιμοποιείται για την επιβεβαίωση της τιμής που έχει οριστεί κατά τον προγραμματισμό μιας τεχνικής παραμέτρου
1+3	Εμπλοκή και απεμπλοκή κουμπιών
2+3	Όταν ο λέβητας βρίσκεται σε κατάσταση OFF, χρησιμοποιείται για την ενεργοποίηση της λειτουργίας ανάλυσης καύσης (CO)

	Υποδεικνύει τη σύνδεση με απομακρυσμένη συσκευή (OTBus ή RS485)
	Υποδεικνύει σύνδεση με συσκευή WIFI
	Υποδεικνύει την παρουσία εξωτερικού αισθητήρα
	Υποδεικνύει την ενεργοποίηση ειδικών λειτουργιών ζεστού νερού χρήσης ή την παρουσία εγκατάστασης για τη διαχείριση ηλιακής θέρμανσης
	Εικονίδιο που ανάβει σε περίπτωση συναγερμού
	Ανάβει σε περίπτωση ανωμαλίας μαζί με το εικονίδιο  , εκτός από τους συναγερμούς φλόγας και νερού
	Υποδεικνύει την παρουσία φλόγας, σε περίπτωση μπλοκαρίσματος της φλόγας εμφανίζεται το εικονίδιο 
	Αναβοσβήνει με προσωρινούς συναγερμούς νερού, παραμένει σταθερό με οριστικούς συναγερμούς
	Ανάβει με την παρουσία συναγερμών που απαιτούν χειροκίνητη απεμπλοκή από τον χειριστή
	Ανάβει όταν ζητείται λειτουργία επιβεβαίωσης
	Όταν το εικονίδιο είναι ενεργό, υποδεικνύει ότι η λειτουργία «επιβεβαίωσης» του κουμπιού είναι ενεργή A
	Όταν το εικονίδιο είναι ενεργό, υποδεικνύει ότι είναι ενεργή η λειτουργία «επιστροφή/ακύρωση» του κουμπιού B
	Όταν το εικονίδιο είναι ενεργό, είναι δυνατή η πλοήγηση στο μενού ή η αύξηση της τιμής της επιλεγμένης παραμέτρου
	Όταν το εικονίδιο είναι ενεργό, είναι δυνατή η πλοήγηση στο μενού ή η μείωση της τιμής της επιλεγμένης παραμέτρου
	Το εικονίδιο ανάβει εάν η θέρμανση είναι ενεργή, αναβοσβήνει εάν υπάρχει αίτημα θέρμανσης
	Το εικονίδιο ανάβει εάν η λειτουργία ζεστού νερού χρήσης είναι ενεργή, αναβοσβήνει εάν υπάρχει αίτημα ζεστού νερού χρήσης
	Υποδεικνύουν το επίπεδο του σημείου ρύθμισης (ελάχιστη τιμή 1 εγκοπή, μέγιστη τιμή 4 εγκοπές)
1 2 3 4 5 6 7	Υποδεικνύει τις ημέρες της εβδομάδας
AUTO ON	Ωριαίος προγραμματισμός
MAN ON	Μη αυτόματος ωριαίος προγραμματισμός ON
MAN OFF	Μη αυτόματος ωριαίος προγραμματισμός OFF

8 ΟΔΗΓΙΕΣ ΧΡΗΣΗΣ

- Τοποθετήστε τον γενικό διακόπτη του συστήματος στη θέση «αναμμένο»
- Ανοίξτε τη βάνα αερίου για να επιτραπεί η ροή του καυσίμου.
- Κατά την ενεργοποίηση, ανάβει ο οπίσθιος φωτισμός, ανάβουν όλα τα εικονίδια και τμήματα για 1 δευτερόλεπτο και στη συνέχεια η αναθεώρηση του υλικολογισμικού, της μόνης πλακέτας ελέγχου, εμφανίζεται για 3 δευτερόλεπτα:

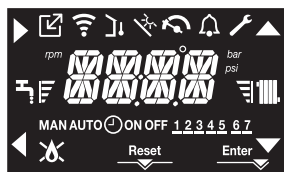

Εάν δεν έχει ρυθμιστεί, ο προγραμματισμός της ώρας και της ημέρας της εβδομάδας ζητείται αυτόματα κατά την ενεργοποίηση της συσκευής. Στην κύρια οθόνη ανάβουν τα εικονίδια ▲, ▼, ► και ◀ και το ENTER ενώ η ένδειξη 00:00 εμφανίζεται με τους δύο πρώτους αριθμούς που αναβοσβήνουν με συχνότητα 0,5 δευτερολέπτων στην κατάσταση ON, 0,5 δευτερολέπτων στην κατάσταση OFF.



Ακολουθήστε τις παρακάτω οδηγίες για να ρυθμίσετε την ώρα και την ημέρα:

- ρυθμίστε την ώρα με τα βέλη ▲ και ▼, στη συνέχεια επιβεβαιώστε με το κουμπί A
- ρυθμίστε τα λεπτά με τα βέλη ▲ και ▼ στη συνέχεια επιβεβαιώστε με το κουμπί A
- ρυθμίστε την ημέρα της εβδομάδας χρησιμοποιώντας τα βέλη ▲ και ▼. Το τμήμα στην επιλεγμένη ημέρα αναβοσβήνει, πατήστε το κουμπί MENU στο εικονίδιο Enter για να επιβεβαιώσετε τη ρύθμιση ώρας και ημέρας. Το ρολόι αναβοσβήνει για 4 δευτερόλεπτα και στη συνέχεια επιστρέφει στην κύρια οθόνη
- Για να βγείτε από τον προγραμματισμό ώρας χωρίς να αποθηκεύσετε τις τροποποιημένες τιμές, απλά πατήστε το κουμπί ◀.

ΣΗΜΕΙΩΣΗ: Οι ρυθμίσεις ΩΡΑ και ΗΜΕΡΑ μπορούν επίσης να αλλάξουν αργότερα, αποκτώντας πρόσβαση στο μενού ΡΥΘΜΙΣΕΙΣ, παράμετρος P1 → P102, ή πατώντας το κουμπί A+C για τουλάχιστον 2 δευτερόλεπτα.

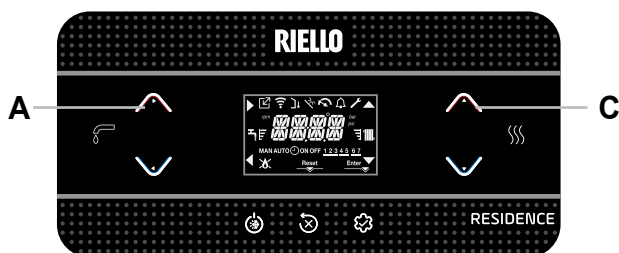

- Στη συνέχεια ξεκινά ο κύκλος αυτόματης εξαέρωσης, εάν είναι ενεργοποιημένος, που διαρκεί 4 λεπτά (για λεπτομέρειες βλ. παράγραφο «5.3 Κύκλος εξαέρωσης»).
 - Έπειτα, η διεπαφή θα μεταβεί στην οθόνη που σχετίζεται με την ενεργή κατάσταση εκείνη τη στιγμή.
-  Ρυθμίστε τον θερμοστάτη χώρου στην επιθυμητή θερμοκρασία ή, εάν η εγκατάσταση διαθέτει χρονοθερμοστάτη ή προγραμματιστή ωραρίου, βεβαιωθείτε ότι είναι «ενεργός» ή ρυθμισμένος.
- Θέστε αμέσως μετά τον λέβητα σε θέση ΧΕΙΜΩΝΑΣ ή ΚΑΛΟΚΑΙΡΙ.

8.1 Λειτουργία ωριαίου προγράμματος (θερμοστάτης χώρου)

Εάν η διαχείριση της εγκατάστασης θέρμανσης γίνεται από θερμοστάτη χώρου και συνεπώς δεν έχει ωριαίο προγραμματισμό, μπορεί να ενεργοποιηθεί ο ωριαίος προγραμματισμός στη διεπαφή του λέβητα ρυθμίζοντας την παράμετρο P4 → P421 = 1.

Για να ενεργοποιήσετε το μενού του ωριαίου προγραμματισμού αυτόματης θέρμανσης, πατήστε τα κουμπιά B+D για τουλάχιστον 2 δευτερόλεπτα στην κύρια οθόνη.

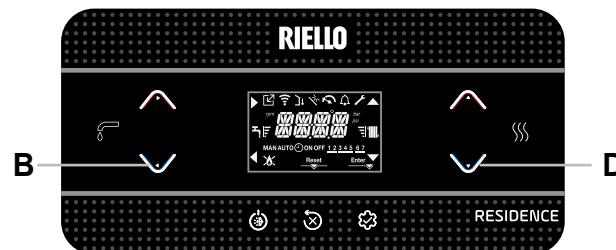

Η οθόνη μοιάζει με την ακόλουθη εικόνα:

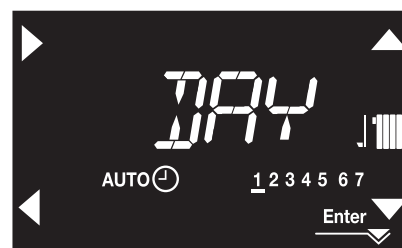

Με τα βέλη ▲, ▼ επιλέγετε την προεπιλεγμένη ημέρα ή ομάδα ημερών:

- 1-2-3-4-5-6-7 προγραμματισμός μεμονωμένων ημερών
- 1-5 προγραμματισμός από Δευτέρα έως Παρασκευή
- 6-7 προγραμματισμός από Σάββατο έως Κυριακή
- 1-7 προγραμματισμός ολόκληρης εβδομάδας

Με το κουμπί ► επιβεβαιώνετε την επιλογή και προχωράτε στον προγραμματισμό των ωριαίων ζωνών, με το κουμπί Enter εξέρχετε από τον ωριαίο προγραμματισμό επιβεβαιώνοντας τις τροποποιήσεις που έγιναν.

Με το κουμπί ◀ βγαίνετε από τον προγραμματισμό ακυρώνοντας τις επιλογές.

Ρύθμιση ωριαίων ζωνών

- Στην οθόνη εμφανίζεται η ένδειξη ΩΡΑ ON 1, πιέστε ► για να ρυθμίσετε το ωράριο ενεργοποίησης, με το ▲, ▼ τροποποιείτε το ωράριο και επιβεβαιώνετε με το ►.
- Στην οθόνη εμφανίζεται η ένδειξη ΩΡΑ OFF 1, πιέστε ► για να ρυθμίσετε το ωράριο απενεργοποίησης, με το ▲, ▼ τροποποιείτε το ωράριο και επιβεβαιώνετε με το ►.
- Εμφανίζεται η ένδειξη ΩΡΑ ON 2, έπειτα συνεχίζεται ο προγραμματισμός των ωριαίων ζωνών μέχρι να επιτευχθεί ο μέγιστος αριθμός προγραμματιζόμενων ζωνών (τέσσερις), ή πατήστε Enter για να επιβεβαιώσετε τις ρυθμισμένες ζώνες και να προχωρήσετε στον προγραμματισμό της επόμενης ημέρας.

Εκτός αυτών των ωριαίων ζωνών, τα αιτήματα θερμότητας από θερμοστάτη χώρου δεν λαμβάνονται υπόψη.

Οι ωριαίες ζώνες **θέρμανσης** που είναι ενεργοποιημένες από προεπιλογή είναι:

- από ΔΕΥ έως ΠΑΡ: 07:30 ÷ 08:30 / 12:00 ÷ 13:30 / 18:00 ÷ 22:30
- από ΣΑΒ έως ΚΥΡ: 08:00 ÷ 22:30.

Όταν είναι ενεργοποιημένος ο ωριαίος προγραμματισμός θέρμανσης, πατώντας τα κουμπιά **C+D** γίνεται εναλλαγή μεταξύ του ωριαίου προγραμματισμού AUTO και MAN ON ή MAN OFF.

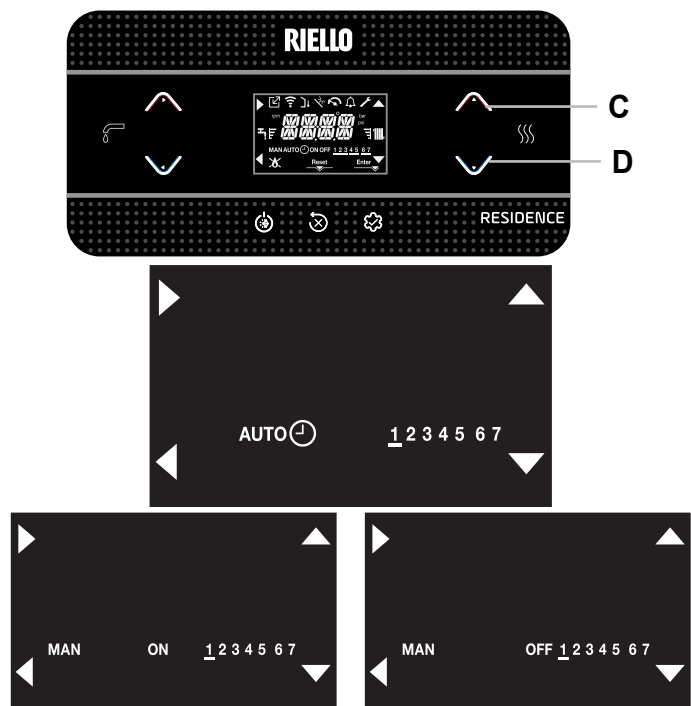

8.2 Κατάσταση λειτουργίας

- Με το πάτημα του κουμπιού 1, ο τύπος λειτουργίας αλλάζει κυκλικά από OFF - ΚΑΛΟΚΑΙΡΙ - ΧΕΙΜΩΝΑΣ και τέλος πάλι OFF.

⚠ Στην κατάσταση OFF, η τιμή της πίεσης του νερού εμφανίζεται στην οθόνη κάθε 2 δευτερόλεπτα.

- Εάν δεν πατηθεί κανένα κουμπί για 60 δευτερόλεπτα, η διεπαφή μεταβαίνει σε κατάσταση αναμονής. Κανονικά εμφανίζεται η τιμή της πίεσης, εκτός εάν υπάρχει αίτημα θερμότητας (οπότε εμφανίζεται στην οθόνη η θερμοκρασία). Σε περίπτωση που έχει ρυθμιστεί η ώρα, η τιμή πίεσης αντικαθίσταται από την τρέχουσα ώρα.

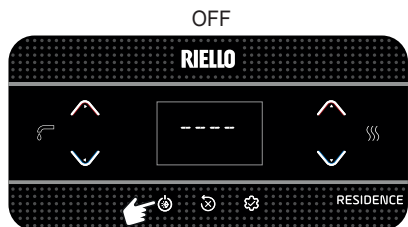

ΚΑΤΑΣΤΑΣΗ ΧΕΙΜΩΝΑΣ

Ο λέβητας ενεργοποιεί τη λειτουργία θέρμανσης και ζεστού νερού χρήσης, η παρουσία του εικονιδίου «» υποδεικνύει αίτημα θερμότητας και έναυση του καυστήρα.

ΠΟΛΙΤΕΙΑ ΧΕΙΜΩΝΑ

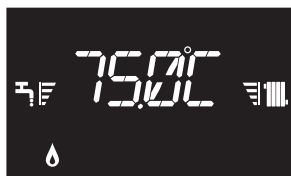

ΚΑΤΑΣΤΑΣΗ ΚΑΛΟΚΑΙΡΙ

Ο λέβητας ενεργοποιεί την παραδοσιακή λειτουργία μόνο για ζεστό νερό χρήσης.

ΚΑΛΟΚΑΙΡΙΝΗ ΚΑΤΑΣΤΑΣΗ



8.3 Ρύθμιση σημείου ρύθμισης θέρμανσης

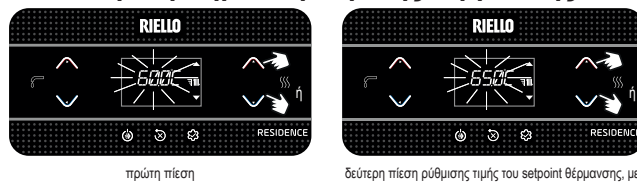

πρώτη πίεση

δεύτερη πίεση ρύθμισης τιμής του setpoint θέρμανσης, με διαβαθμίσεις 0,5 °C

Εάν δεν πατηθεί κανένα κουμπί για 5 δευτερόλεπτα, η ρυθμισμένη τιμή λαμβάνεται ως το νέο σημείο ρύθμισης θέρμανσης.

8.4 Ρύθμιση σημείου ρύθμισης θέρμανσης με εξωτερικό αισθητήρα

Με συνδεδεμένο εξωτερικό αισθητήρα (προαιρετικά) και ενεργοποιημένη τη θερμορύθμιση (παράμετρος **P4** → P418=1), η τιμή της θερμοκρασίας παροχής επιλέγεται αυτόματα από το σύστημα, το οποίο ρυθμίζει γρήγορα τη θερμοκρασία του χώρου ανάλογα με τις μεταβολές της εξωτερικής θερμοκρασίας.

Τροποποίηση του σημείου ρύθμισης θέρμανσης



Η διόρθωση του σημείου ρύθμισης είναι εντός εύρους (-5 έως +5°C) Με παράμετρο **P4** → P418=0 ο λέβητας λειτουργεί σε σταθερό σημείο.

8.5 Ρύθμιση σημείου ρύθμισης ζεστού νερού χρήσης

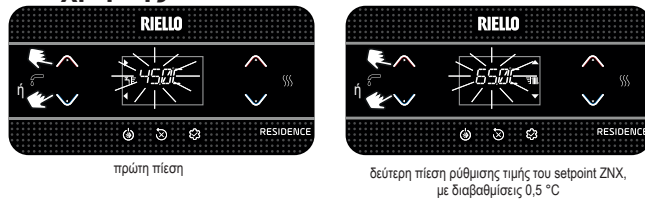

πρώτη πίεση

δεύτερη πίεση ρύθμισης τιμής του setpoint ZNX, με διαβαθμίσεις 0,5 °C

Εάν δεν πατηθεί κανένα κουμπί για 5 δευτερόλεπτα, η ρυθμισμένη τιμή λαμβάνεται ως το νέο σημείο ρύθμισης ζεστού νερού χρήσης.

8.6 Διακοπή ασφαλείας

Σε περίπτωση που διαπιστωθούν ανωμαλίες στην έναυση ή τη λειτουργία, ο λέβητας θα πραγματοποιήσει μια «ΔΙΑΚΟΠΗ ΑΣΦΑΛΕΙΑΣ». Στην οθόνη εμφανίζεται ο κωδικός σφάλματος που παρουσιάστηκε. Για λεπτομέρειες βλέπε «5.14 Ενδείξεις και ανωμαλίες».

Λειτουργία απεμπλοκής

Επικοινωνήστε με την τοπική Υπηρεσία Τεχνικής Υποστήριξης, εάν οι προσπάθειες απεμπλοκής δεν αποκαταστήσουν την κανονική λειτουργία.

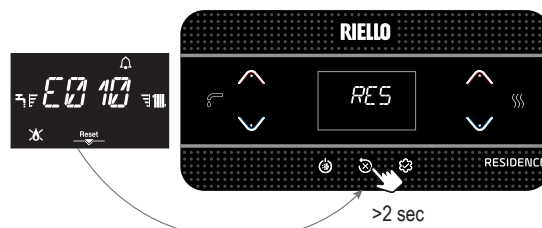

8.7 Προσωρινή απενεργοποίηση

Σε περίπτωση σύντομης απουσίας (Σαββατοκύριακα, σύντομα ταξίδια, κ.τλ.), ρυθμίστε την κατάσταση του λέβητα στη θέση OFF.

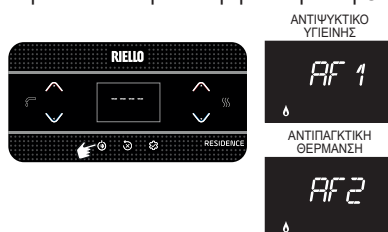

Αφήνοντας ενεργή την ηλεκτρική τροφοδοσία και την τροφοδοσία καυσίμου, το σύστημα προστατεύεται από τα εξής συστήματα:

- αντιπαγετική θέρμανση:** η λειτουργία που ενεργοποιείται εάν η θερμοκρασία που ανιχνεύεται από τον αισθητήρα παροχής πέφτει κάτω από 5°C. Σε αυτήν τη φάση παράγεται ένα αίτημα θερμότητας

με έναυση του καυστήρα στην ελάχιστη ισχύ. Διατηρείται έως ότου η θερμοκρασία του νερού παροχής φτάσει τους 35°C. Στην οθόνη εμφανίζεται η ένδειξη AF2 με P105 = 1 ΚΥΛΙΣΗ --> ΑΝΤΙΠΑΓΕΤΙΚΗ ΛΕΙΤΟΥΡΓΙΑ ΘΕΡΜΑΝΣΗΣ ΣΕ ΕΞΕΛΙΞΗ)

- **αντιπαγετική ζεστού νερού χρήση:** η λειτουργία που ενεργοποιείται εάν η θερμοκρασία που ανιχνεύεται από τον αισθητήρα παροχής πέφτει κάτω από 5°C. Σε αυτήν τη φάση παράγεται ένα αίτημα θερμότητας με έναυση του καυστήρα στην ελάχιστη ισχύ, που διατηρείται έως ότου η θερμοκρασία του νερού παροχής φτάσει τους 55°C. Στην οθόνη εμφανίζεται η ένδειξη AF1 (με P105 = 1 ΚΥΛΙΣΗ --> ΑΝΤΙΠΑΓΕΤΙΚΗ ΛΕΙΤΟΥΡΓΙΑ ΖΝΧ ΣΕ ΕΞΕΛΙΞΗ)
- **αντιμπλοκάρισμα κυκλοφορητή:** ο κυκλοφορητής ενεργοποιείται κάθε 24 ώρες αναμονής για ένα διάστημα 30 δευτερολέπτων.

8.8 Απενεργοποίηση για μεγάλες περιόδους

Σε περίπτωση μη χρήσης του λέβητα για μεγάλη περίοδο απαιτείται να γίνουν οι ακόλουθες εργασίες:

- ρυθμίστε την κατάσταση OFF
- τοποθετήστε το γενικό διακόπτη της εγκατάστασης σε θέση «σβηστό»
- Κλείστε τις βάνες καυσίμου και νερού της εγκατάστασης θέρμανσης και ζεστού νερού χρήσης.

Σε αυτήν την περίπτωση το αντιπαγετικό σύστημα και το σύστημα αντιμπλοκαρίσματος είναι απενεργοποιημένα. Αδειάστε την εγκατάσταση θέρμανσης και ζεστού νερού χρήσης, εάν υπάρχει κίνδυνος παγώματος.

8.9 Λειτουργία κλειδώματος πληκτρολογίου

Για να κλειδώσετε τα κουμπιά

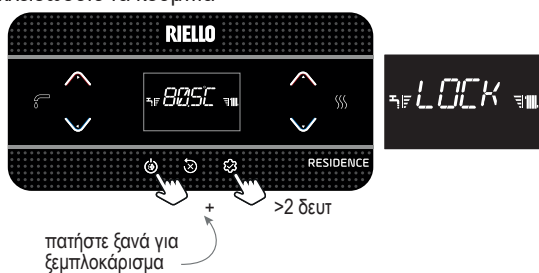

Σε περίπτωση ανωμαλίας, το κουμπί 2 παραμένει ενεργό για να επιτρέψει τον μηδενισμό του συναγερμού.

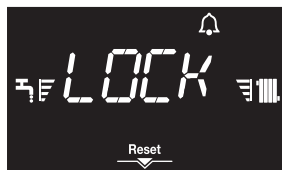

8.10 Ιστορικό συναγερμών

Το ιστορικό συναγερμών είναι ενεργό με την παράμετρο P7 → P701=1 (ΣΕΡΒΙΣ).

Οι συναγερμοί μπορούν να προβληθούν ως εξής:

- στο μενού INFO (I039 έως I043), με χρονολογική σειρά, από τον νεότερο προς τον παλαιότερο, με μέγιστο αριθμό 5.

Όταν ένας συναγερμός εμφανίζεται πολλές φορές στη σειρά, αποθηκεύεται μόνο μία φορά.

Για να επαναφέρετε τον συναγερμό, ακολουθήστε τις οδηγίες που δίνονται στην παράγραφο «8.6 Διακοπή ασφαλείας».

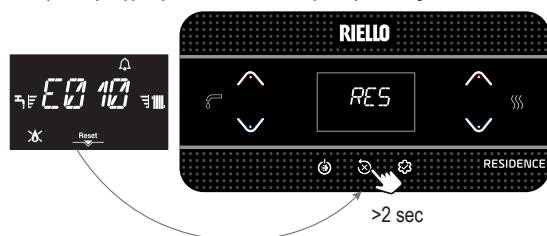

8.11 Μενού συνδεσιμότητας

Η απομακρυσμένη διαχείριση του λέβητα μπορεί να γίνει μέσω:

- Κλειδί Wi-Fi (μη διαθέσιμο)

Είναι επίσης δυνατή η ενεργοποίηση της απομακρυσμένης διαχείρισης μέσω ενός χρονοθερμοστάτη OpenTherm.

Σημείωση: Δεν διασφαλίζεται η πλήρης συμβατότητα με συσκευές OpenTherm τρίτων κατασκευαστών.

Σημείωση: το τηλεχειριστήριο T100 δεν μπορεί να συνδεθεί στο λέβητα εάν το σύστημα είναι υβριδικό (παρουσία αντλίας θερμότητας).

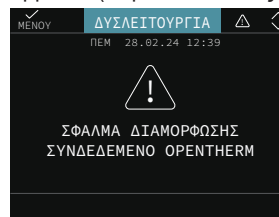

8.12 Λειτουργία ΤΡΟΦΟΔΟΤΗ ΦΙΑΛΩΝ

Η λειτουργία τροφοδότη φιαλών επιτρέπει το κλείδωμα της τιμής που έχει οριστεί στο σημείο ρύθμισης ζεστού νερού χρήσης, εμποδίζοντας κάποιον να την τροποποιήσει κατά λάθος.

Για να ενεργοποιήσετε τη λειτουργία τροφοδότη φιαλών, από την οθόνη του σημείου ρύθμισης ζεστού νερού χρήσης:

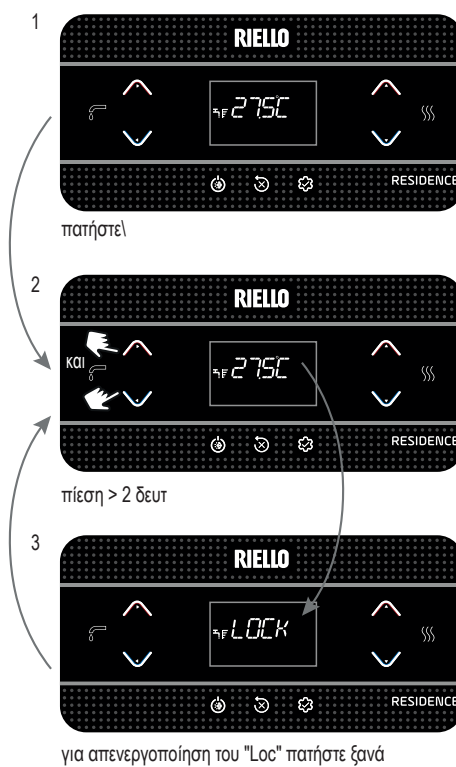

9 GENERAL SECTION • SECȚIUNEA GENERALĂ • ΓΕΝΙΚΟ ΤΜΗΜΑ

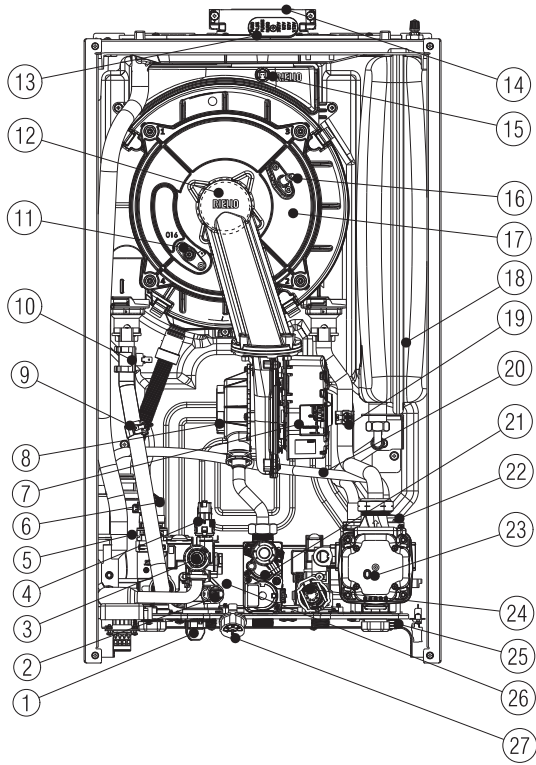

9.1	[EN] - General boiler layout	[EL] - Διάταξη λέβητα	[RO] - Structura cazanului
1	Filling tap	Βάνα πλήρωσης	Robinet de umplere
2	Domestic hot water NTC probe	Αισθητήρας Z.N.X. NTC	Sondă NTC circuit apă menajeră
3	Safety valve	Βαλβίδα ασφαλείας	Supapă de siguranță
4	Pressure transducer	Μετατροπέας πίεσης	Tranductor de presiune
5	Syphon	Σιφόνι	Sifon
6	3-way valve	Τριοδική βαλβίδα	Vană cu 3 căi
7	Fan	Βεντιλατέρ	Ventilator
8	Mixer	Αναμικτήρας	Mixer
9	NTC delivery probe	Αισθητήρας NTC παροχής	Sondă NTC tur
10	Limit thermostat	Θερμοστάτης ορίου	Termostat limită
11	Flame detection electrode/ ionisation sensor	Ηλεκτρόδιο ανίχνευσης φλόγας/αισθητήρας ιονισμού	Electrod detectare flacără/senzor ionizare
12	Burner	Καυστήρας	Arzător
13	Combustion analysis socket plug	Καπάκι υποδοχής ανάλυσης καύσης	Capac priză de analiză a arderii
14	Flue gas exhaust	Εξαγωγή καπνών	Evacuare gaze de ardere
15	Flue gas probe	Αισθητήρας καπνών	Sondă gaze arse
16	Flame ignition electrode	Ηλεκτρόδιο ανάφλεξης φλόγας	Electrod de aprindere flacără
17	Exchanger	Εναλλάκτης	Schimbător
18	Expansion vessel	Δοχείο διαστολής	Vas de expansiune
19	NTC return probe	Αισθητήρας NTC επιστροφής	Sondă NTC retur
20	Degassing pipe	Σωλήνας απαέρωσης	Conducta de degazare
21	Gas valve	Βαλβίδα αερίου	Supapă de gaz
22	Air vent valve	Βαλβίδα εξαέρωσης	Supapă de aerisire
23	Circulator	Κυκλοφορητής	Circulator
24	Flow meter	Μετρητής ροής ZNX	Debitmetru
25	Drain tap	Βάνα εκκένωσης εγκατάστασης	Robinet de evacuare
26	DHW heat exchanger	Εναλλάκτης ζεστού νερού χρήσης	Schimbător circuit ACM
27	Hydrometer	Υδρόμετρο	Hidrometru

9.2 Overall dimensions • Dimensiunile per total • Εξωτερικές διαστάσεις

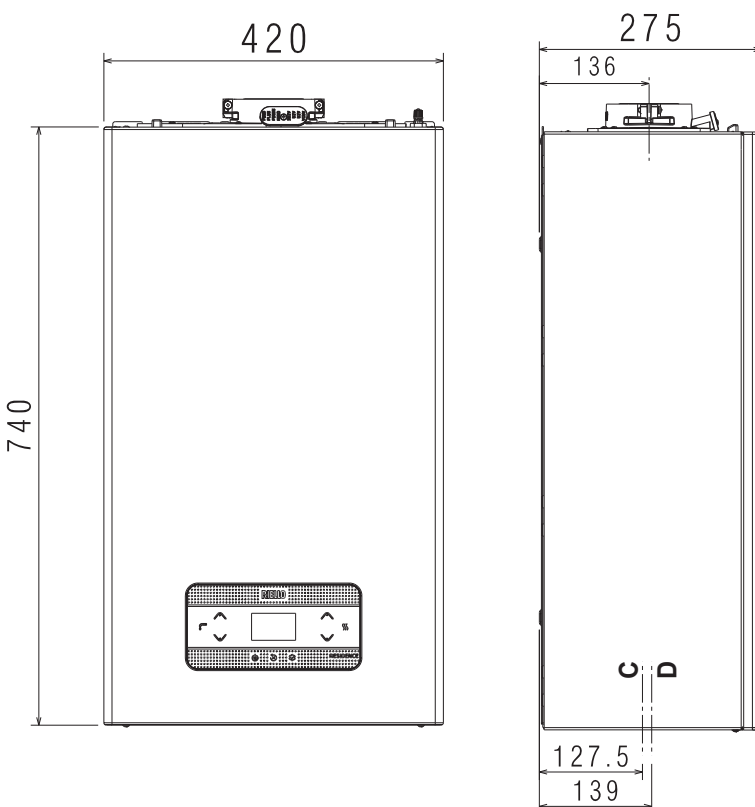



	EN Weight	RO Greutate	EL Βάρος
25 HM BIS	29 kg		
35 HM BIS	30 kg		

	EN	RO	EL
C	water	apă	νερό
D	gas	gaz	αέριο

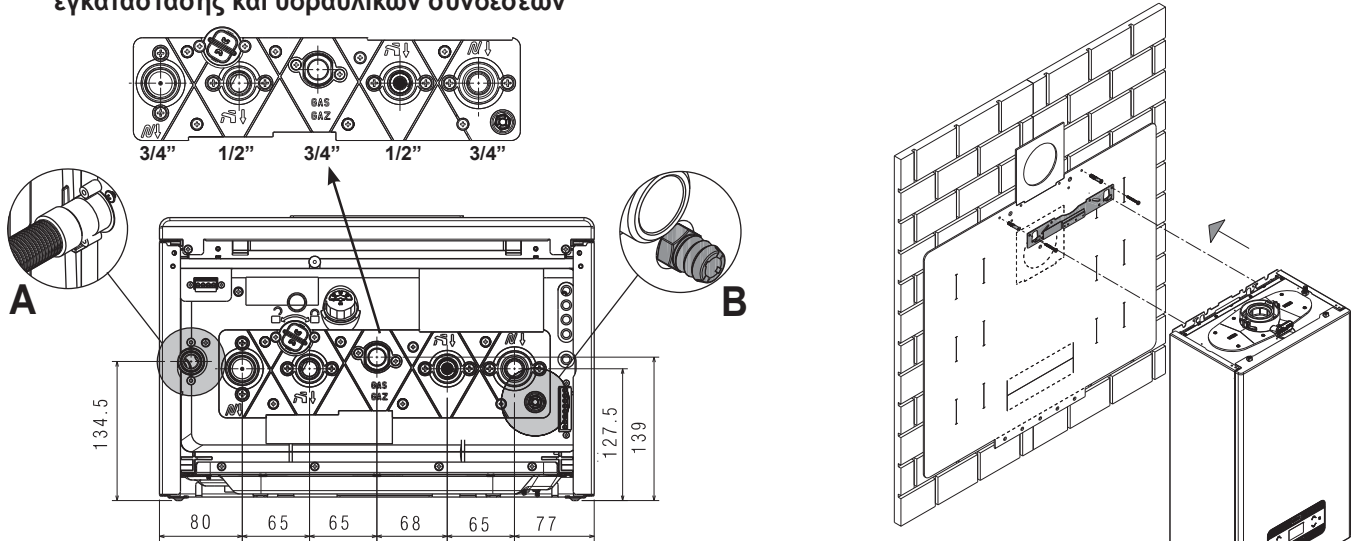
9.3 Installation template and hydraulic connections • Şablon de instalare și conexiuni hidraulice • Περίγραμμα εγκατάστασης και υδραυλικών συνδέσεων



	A	B
EN	safety valve and siphon drain	system drain tap
RO	scurgere sifon si supapa de siguranta	robinet de scurgere a sistemului
EL	αποστράγγιση σιφονιού και βαλβίδα ασφαλείας	βάνα εκκένωσης εγκατάστασης

EN	RO	EL		
TIGHTENING TORQUE	CUPLUL DE STRINGERE	ΡΟΠΗ ΣΥΣΦΙΞΗΣ	Ø 3/4"	35Nm
			Ø 1/2"	25Nm

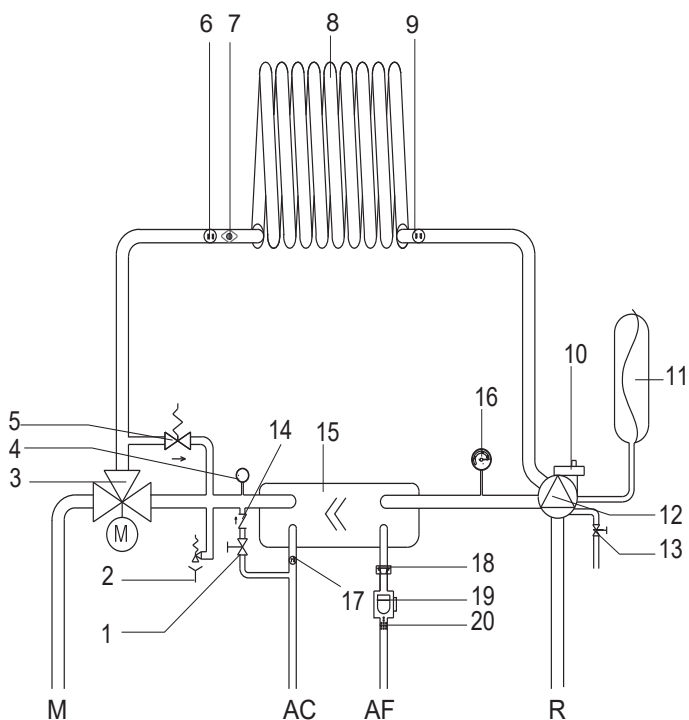

	[EN] - Hydraulic circuit	[RO] - Circuit hidraulic
AC	Hot water	Apă caldă
AF	Cold water	Apă rece
M	Heating delivery	Tur circuit de încălzire
R	Heating return	Retur circuit de încălzire
1	Filling tap	Robinet de umplere
2	Safety valve	Supapă de siguranță
3	Three-way valve	Vană cu trei căi
4	Pressure transducer	Traductor presiune
5	Automatic by-pass	By-pass automat
6	Delivery probe	Sondă tur
7	Limit thermostat	Termostat limită
8	Primary heat exchanger	Schimbător principal
9	Return probe	Sondă retur
10	Lower air vent valve	Supapă inferioară de aerisire
11	Expansion vessel	Vas de expansiune
12	Circulator	Pompă de circulație
13	System drain tap	Robinet de golire
14	Non-return valve	Supapă de sens
15	DHW heat exchanger	Schimbător circuit apă menajeră
16	Hydrometer	Hidrometru
17	DHW probe	Sondă apă caldă menajeră
18	Flow rate limiter	Limitator de debit
19	Flow meter	Debitmetru
20	DHW filter	Filtru ACM

[EL] - Υδραυλικό κύκλωμα	
AC	Ζεστό νερό
AF	Κρύο νερό
M	Παροχή θέρμανσης
R	Επιστροφή θέρμανσης
1	Βάνα πλήρωσης
2	Βαλβίδα ασφαλείας
3	Τρίοδη υδραυλική βαλβίδα
4	Μετατροπέας πίεσης
5	By-pass αυτόματο
6	Αισθητήρας παροχής
7	Θερμοστάτης ορίου
8	Πρωτεύων εναλλάκτης
9	Αισθητήρας επιστροφής
10	Κάτω βαλβίδα εξαέρωσης
11	Δοχείο διαστολής
12	Κυκλοφορητής
13	Βάνα εκκένωσης εγκατάστασης
14	Βαλβίδα αντεπιστροφής
15	Εναλλάκτης ζεστού νερού χρήσης
16	Υδρόμετρο
17	Αισθητήρας ZNX
18	Περιοριστής παροχής
19	Μετρητής ροής ZNX
20	Φίλτρο ZNX

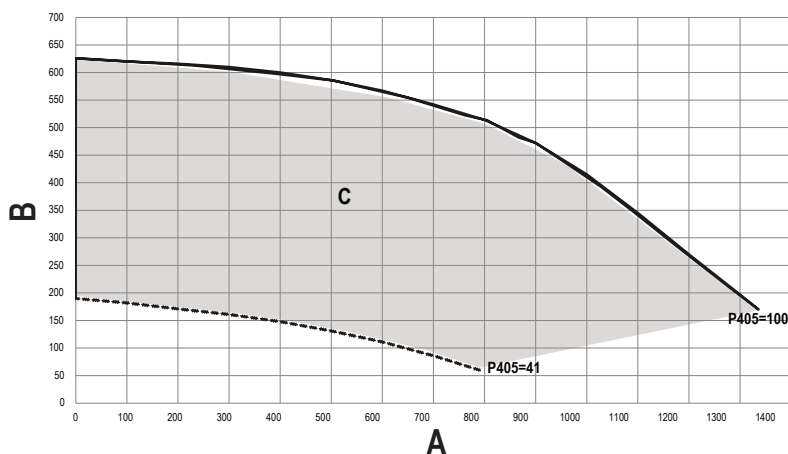

	A	B	C
EN	Flow rate (l/h)	Residual head (mbar)	Modulation area
RO	Debit (l/h)	Sarcină reziduală (mbar)	Zona de modulație
EL	Παροχή εγκατάστασης (l/min)	Μανομετρικό (mbar)	Περιοχή διαμόρφωσης

EN - Residual head of the circulator

The boiler is equipped with a high-efficiency circulator already hydraulically and electrically connected. The relative usable performance values are shown in the graph.

The circulator motor is equipped with a two-color LED that provides information on the pump status (see table).

NOTE FOR BLOCKED CIRCULATOR

Check the correct value of the boiler supply voltage. If the value is correct, disconnect the power supply for at least 5 seconds and then restore it. If the blockage persists, replace the circulator.

RO - Prevalența reziduală a circulatorului

Centrala este echipată cu circulator cu eficiență ridicată, deja conectat hidraulic și electric, ale cărui performanțe utile disponibile sunt indicate în grafic.

Motorul de circulație este echipat cu un LED bicolor care oferă informații despre starea pompei (vezi tabel).

NOTĂ PENTRU POMPĂ DE CIRCULAȚIE BLOCATĂ

Verificați valoarea corectă a tensiunii de alimentare a cazanului. Dacă valoarea este corectă, deconectați alimentarea timp de cel puțin 5 secunde și apoi restabiliți-o. Dacă blocajul persistă, înlocuiți circulatorul.

EL - Υπολειπόμενο μανομετρικό ύψος κυκλοφορητή

Ο λέβητας εξοπλίζεται με έναν κυκλοφορητή υψηλής απόδοσης ήδη συνδεδεμένο υδραυλικά και ηλεκτρικά, οι διαθέσιμες επιδόσεις του οποίου αναγράφονται στο γράφημα.

Ο κινητήρας του κυκλοφορητή είναι εξοπλισμένος με δίχρωμο LED που παρέχει πληροφορίες για την κατάσταση της αντλίας (βλ. πίνακα).

ΣΗΜΕΙΩΣΗ ΓΙΑ ΜΠΛΟΚΑΡΙΣΜΕΝΟ ΚΥΚΛΟΦΟΡΗΤΗ

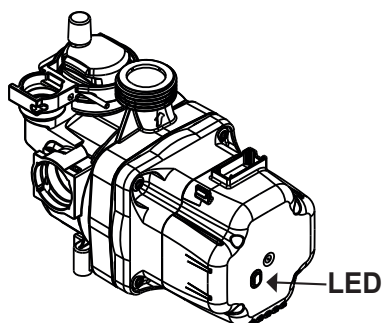

Ελέγξτε τη σωστή τιμή της τάσης τροφοδοσίας του λέβητα. Εάν η τιμή είναι σωστή, αποσυνδέστε την τροφοδοσία ρεύματος για τουλάχιστον 5 δευτερόλεπτα και μετά αποκαταστήστε την. Εάν το μπλοκάρισμα επιμένει, αντικαταστήστε τον κυκλοφορητή.



EN		RO	
LED	Description	LED	Descriere
green	Pump runs normally	verde	Pompa funcționează normal
red	Pump error: blocked rotor, low voltage, electronic fault	roșu	Eroare la pompă: rotor blocat, tensiune scăzută, defecțiune electronică
OFF	Pump OFF: no power or standby mode	OFF	Pompă OPRITĂ: fără alimentare sau mod standby

EL	
LED	Περιγραφή
πράσινος	Η αντλία λειτουργεί κανονικά
κόκκινος	Σφάλμα αντλίας: φραγμένος ρότορας, χαμηλή τάση, ηλεκτρονικό σφάλμα
OFF	Αντλία OFF: χωρίς τροφοδοσία ή λειτουργία αναμονής

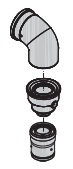
	EN - ACCESSORIES	RO - ACCESORII	EL - ΕΞΑΡΤΗΜΑΤΑ
	X4 Dossieret power supply L (brown) - N (blue)	Alimentare Dossieret L (maro) - N (albastru)	Τροφοδοτικό Dossieret L (καφέ) - N (μπλε)
	CE8 TA: (room thermostat)	TA: (termostat de cameră)	TA: (θερμοστάτης χώρου)
	CE8 OT+	OT+	OT+
	CE8 SE: outdoor temperature sensor	SE: senzor de temperatură exterioară	SE: (εξωτερικός αισθητήρας)
	CE8 TBT: Low temperature limit thermostat	TBT: Termostat limită temperatură scăzută	TBT: Θερμοστάτης χαμηλής θερμοκρασίας
	X10 Alarm remote control	Control de la distanță de alarmă	Απομακρυσμένος συναγερμός
	X11 Zone valve or additional pump	Supapei zonei sau pompă suplimentară	Βαλβίδα ζώνης ή συμπληρωματική αντλία
	CE4 Dir/mix zone control	Control direct/mixt de zone	Έλεγχος ζώνης dir/mix
	CE4 Dossieret Kit	Kit Dossieret	Σετ Dossieret

"A"	"B"	"C"	"D"	"C"	"D"	"E"		"H"
		25 HM BIS		35 HM BIS		"F"	"G"	
 <p>90° bend Ø80-125 • curba 90° Ø80-125 • γωνία 90° Ø80-125 adaptor from Ø60-100 to Ø80-125 • adaptor de la Ø60-100 la Ø80-125 • αντάπτορας Ø60-100 έως Ø80-125 adaptor vertical connection Ø60-100 • adaptor vertical conexiune Ø60-100 • αντάπτορας κάθετου συνδέσμου Ø60-100</p>	80-125	25	0,85	20	0,85	1	1,5	130
 <p>twin flue pipe from Ø60-100 to Ø80-80 • conductă dublă de fum de la Ø60-100 la Ø80-80 • διπλός σωλήνας καπνοδόχου από Ø60-100 έως Ø80-80</p>	80-80	75+75	0,50	39+39	0,50	1	1,5	-
 <p>Twin flue pipe system with use of the Ø80 twin flue pipe system connection kit (accessory) • Sistem conductă dublă de fum cu utilizarea kit-ului de conectare a sistemului conductă dublă de fum Ø80 (accesoriu) • Σύστημα διπλών σωλήνων καυσαερίων με τη χρήση του kit σύνδεσης sistemului σύστημα διπλών σωλήνων καυσαερίων Ø80 (αξεσουάρ)</p>	80-80	69+69	0,50	36+36	0,50	1	1,5	-

10 SETTING PASSWORD, ACCESS AND PARAMETER MODIFICATION

INTRODUCEREA PASSWORD, ACCESUL ȘI MODIFICAREA PARAMETRILOR

ΡΥΘΜΙΣΗ ΚΩΔΙΚΟΥ, ΠΡΟΣΒΑΣΗΣ ΚΑΙ ΤΡΟΠΟΠΟΙΗΣΗΣ ΠΑΡΑΜΕΤΡΩΝ

Key pressure = light: value progress of one unit at a time; prolonged: fast forward
Presiune cheie = lumină: progresul valorii unei unități la un moment dat; prelungit: înainte rapid
Πίεση πλήκτρων = ελαφριά: προώθηση της τιμής ανά μία μονάδα κάθε φορά, παρατεταμένη: γρήγορη προώθηση

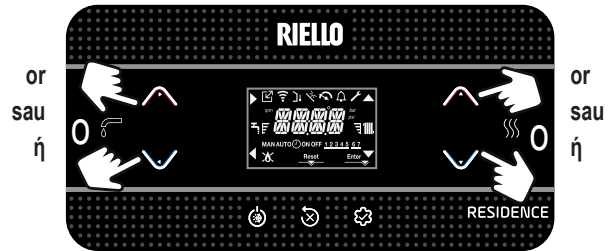

EN	RO	EL
In the manual, whenever necessary: - enter the password to access the parameters - choose, modify and/or confirm parameters. Follow the sequences involved (see table) for more immediate action.	În manual, ori de câte ori este necesar: - introduceți parola pentru a accesa parametrii - alegeți, modificați și/sau confirmați parametrii. Urmăți secvențele implicate (vezi tabelul) pentru acțiuni mai imediate.	Στο εγχειρίδιο, κάθε φορά που καθίσταται απαραίτητο: - εισαγάγετε τον κωδικό πρόσβασης για την πρόσβαση στις παραμέτρους - επιλέξτε, τροποποιήστε ή/και επιβεβαιώστε τις παραμέτρους. Ακολουθήστε τις σχετικές ακολουθίες (δείτε τον πίνακα) για μια πιο άμεση ενέργεια.

EN Actions	RO Acțiuni	EL Ενέργειες	
password entry	introducerea parolei	εισαγωγής κωδικού πρόσβασης	p./σ. 1 - 7
parameter choice	alegerea parametrilor	επιλογή παραμέτρου	p./σ. 8-10
modify and confirm parameter	modificări și confirmați parametrul	τροποποίηση και επιβεβαίωση παραμέτρου	p./σ. 11-12a
exit without saving	iesire fara salvare	έξοδος χωρίς αποθήκευση	p./σ. 12b
return to the main screen	reveniți la ecranul principal	επιστροφή στην κύρια οθόνη	p./σ. 13

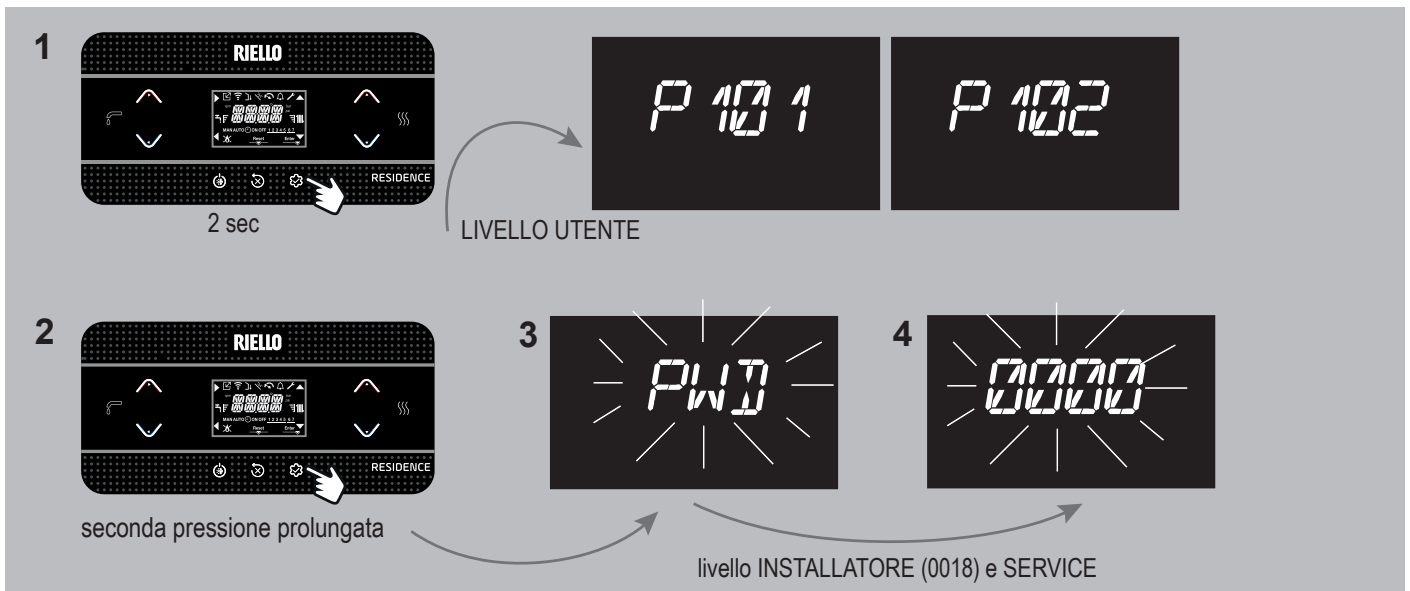

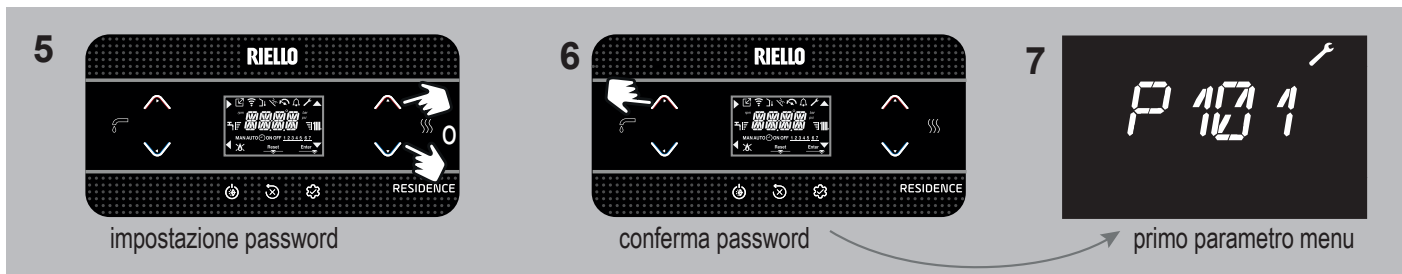

	1	2	3	4	5	6	7
EN	2 sec USER LEVEL	second long press	INSTALLER (0018) and SERVICE LEVEL		password setting	confirm password	first menu parameter
RO	2 sec NIVEL UTILIZATOR	a doua apăsare lungă	INSTALATOR (0018) și NIVEL DE SERVICIU		setarea parolei	confirmă parola	primul parametru de meniu
EL	2 δευτ. ΕΠΙΠΕΔΟ ΧΡΗΣΤΗ	δεύτερη παρατεταμένη πίεση	ΕΠΙΠΕΔΟ ΕΓΚΑΤΑΣΤΑΤΗ (0018) και SERVICE		ρύθμιση κωδικού πρόσβασης	επιβεβαίωση κωδικού πρόσβασης	πρώτη παραμέτρος μενού

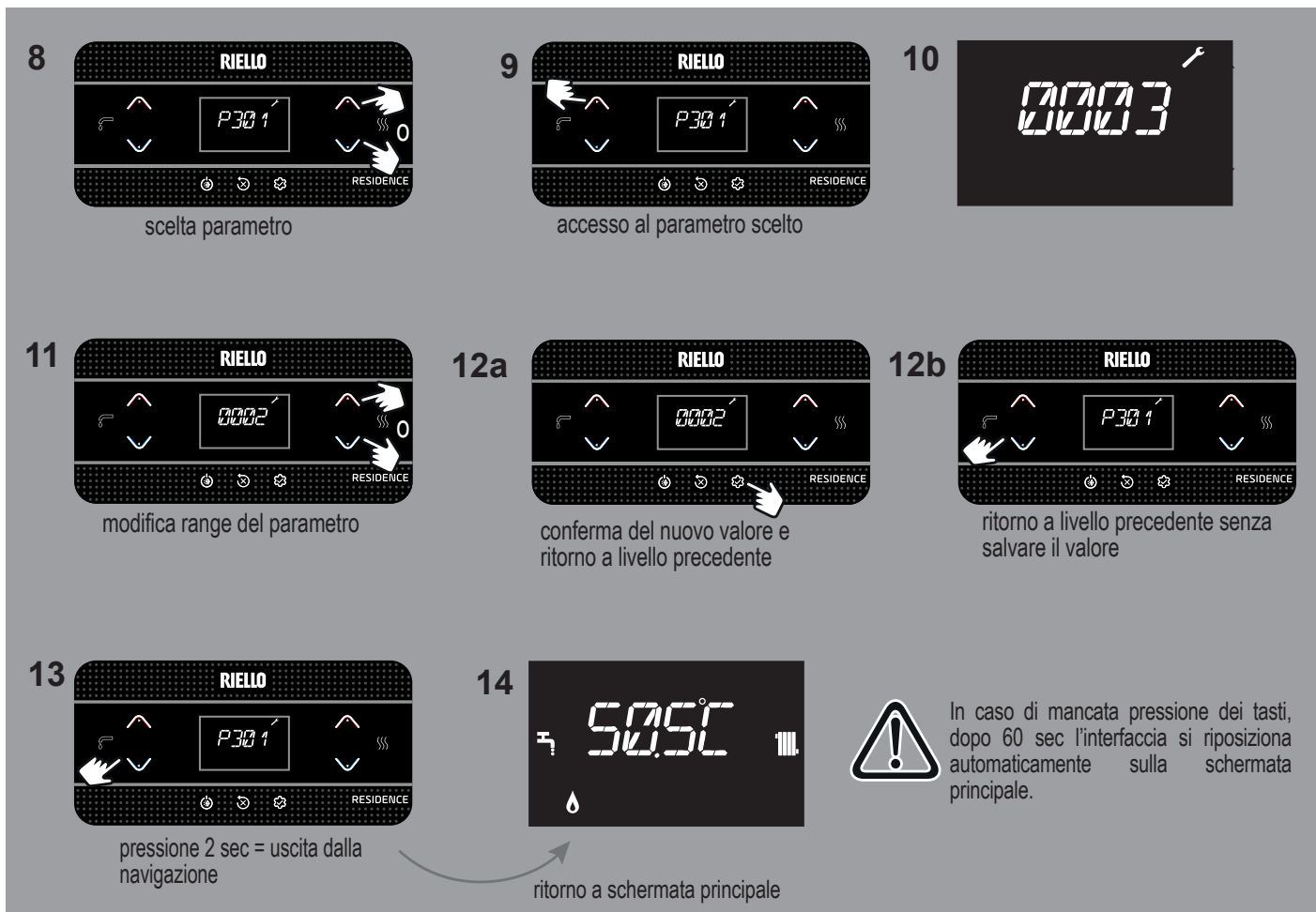

	8	9	11	12a	12b	13	14	
EN	parameter choice	access to the chosen parameter	change range of the parameter	confirmation of the new value and return to the previous level	return to previous level without saving the value	pressure > 2 sec = exit from navigation	return to main screen	If the buttons are not pressed, after 60 seconds the interface will automatically reposition itself on the main screen.
RO	alegerea parametrilor	acces la parametrul ales	modificati intervalul parametrului	confirmarea noii valori și revenirea la nivelul anterior	reveniți la nivelul anterior fără a salva valoarea	presiune > 2 sec = ieșire din navigație	reveniți la ecranul principal	Dacă butoanele nu sunt apăstate, după 60 de secunde interfața se va re poziționa automat pe ecranul principal.
EL	επιλογή παραμέτρου	πρόσβαση στην επιλεγμένη παράμετρο	αλλαγή εύρους παραμέτρου	επιβεβαίωση της νέας τιμής και επιστροφή στο προηγούμενο επίπεδο	επιστροφή στο προηγούμενο επίπεδο χωρίς αποθήκευση της τιμής	πίεση > 2 δευτ. = έξοδος από την πλοήγηση	επιστροφή στην κύρια οθόνη	Σε περίπτωση έλλειψης πίεσης των πλήκτρων, μετά από 60 δευτ. η διεπαφή επανατοποθετείται αυτόματα στην κύρια οθόνη.

RIELLO