



RESIDENCE HM

Wall-hung condensing boilers

Stainless steel primary heat exchanger, robust and high efficiency
High performance oversized domestic hot water heat exchanger
Next-generation self-adaptive combustion control
Designed to function with mixtures of MTN and hydrogen up to a maximum of 20%
High modulation 1:10
IOT Ready



CONDENSING BOILERS

Wall-hung condensing boilers

INDEX

Product description	3
Technical data	4
ERP technical data	8
Table law10	10
Determination of generation losses – Calculation method Directive 92/42 EEC – Data 11300-2	12
Circulator residual discharge head.	13
Dimensions	14
Place of installation	15
Structure.	18
Hydraulic circuit	22
Wiring	23
Control panel	25
Flue gas exhaust and combustion air suction	26
Accessories	33
BAG ³ HYBRID	34
Technical data	34
Structure.	35
Hydraulic connections	36
Brief description for specifications	38
Construction description for specifications	38
Brief description for specifications	40
Construction description for specifications	40

PRODUCT DESCRIPTION

The new RESIDENCE HM range of condensing boilers offers users a combination of comfort and savings. RIELLO proposes a multi energy boiler designed for current and future needs, guaranteeing a reduction in electrical consumption, gas consumption and emissions, with the possibility of remote control.

- Increased sanitary heat exchanger with high performance produced by RIELLO.
- Self-adaptive electronic combustion control ACC (Active Combustion Control).
- Modern and linear design with under-boiler lower connection cover available as an accessory for optimal aesthetic integration.
- Sanitary specific electronic functions: sanitary delay, anti-pendulum function and smart fan.
- Digital modulating circulator 6m low consumption ($IEE \leq 0,20$). High head circulator 7 m available as an accessory.
- Hydraulic group with DIN standard sequence.
- Low noise up to 45 dB.
- 94% seasonal efficiency.
- Modern and intuitive touch screen HMI with representative icons and capacitive buttons with acoustic "buzzer" confirmation.
- 2.8" display with multilingual icons and texts.
- 9 litre expansion tank.
- Easy to install and a wide range of accessories available as options.
- IPX5D electrical protection.
- Gas transformation (Propane Air, LPG) selectable with electronic parameter.
- Fixing template and power supply cable provided.
- Thermoregulation as standard in combination with the outdoor temperature sensor, available as an accessory.
- Flue gases flange with dedicated flue system.

CONDENSING BOILERS

Wall-hung condensing boilers

TECHNICAL DATA

RESIDENCE HM KIS

DESCRIPTION	U.M.	RESIDENCE HM								
		25 KIS			30 KIS			35 KIS		
Gas category		I12HY20M3P			I12HY20M3P			I12HY20M3P		
Country of destination		IT			IT			IT		
Flue gas exhaust installation type		B23P; B53P; C(10); C13, C13x; C33, C33x; C43, C43x; C53, C53x; C63, C63x; C83, C83x, C93, C93x			B23P; B53P; C(10); C13, C13x; C33, C33x; C43, C43x; C53, C53x; C63, C63x; C83, C83x, C93, C93x			B23P; B53P; C(10); C13, C13x; C33, C33x; C43, C43x; C53, C53x; C63, C63x; C83, C83x, C93, C93x		
HEATING		G20	G230	G31	G20	G230	G31	G20	G230	G31
Nominal heat input (Hi)	kW	20,00			25,00			30,00		
Nominal heat output (80-60 °C)	kW	19,53			24,42			29,28		
Nominal heat output (50-30 °C)	kW	21,31			26,51			31,75		
Reduced heat input (Hi)	kW	2,50	3,50	-	3,00	4,20	3,50	3,50	4,20	-
Reduced heat output (80-60 °C)	kW	2,34	-	-	2,87	-	3,30	3,36	-	-
Reduced heat output (50-30 °C)	kW	2,57	-	-	3,19	-	3,65	3,71	-	-
DHW										
Nominal heat input (Hi)	kW	25,00			30,00			34,90	32,00	-
Nominal heat output (*)	kW	25,00			30,00			34,90	-	-
Reduced heat input (Hi)	kW	2,50	3,50	-	3,00	4,20	3,50	3,50	4,20	-
Reduced heat output (*)	kW	2,50	-	-	3,00	-	3,50	3,50	-	-
Modulating ratio		1:10			1:10			1:10		
EFFICIENCY										
Useful efficiency Pn max (80-60 °C)	%	97,7			97,7			97,6		
Useful efficiency Pn min (80-60 °C)	%	93,5			95,5			96,0		
Useful efficiency Pn max (50-30 °C)	%	106,5			106,0			105,8		
Useful efficiency Pn min (50-30 °C)	%	102,9			106,3			106,0		
Useful efficiency 30 % (return 30 °C)	%	109,7			109,6			109,7		
Stack leaks with burner on (Pn max)	%	2,04			2,07			2,17		
Chimney and skirt losses with burner off	%	0,09			0,08			0,07		
Casing leaks with burner on (Pn max)	%	0,30			0,20			0,20		
FLUE GAS EXHAUST										
Nox class - UNI EN 15502		6			6			6		
Residual discharge head concentric pipes 0,85 m Ø 60-100 mm	Pa	60			60			60		
Residual discharge head separate pipes 0,5 m Ø 80 mm	Pa	180			195			195		
Residual discharge head boiler without pipes max. output.	Pa	186			199			199		
Residual discharge head boiler without pipes min. output.	Pa	50			50			50		
ELECTRICAL CHARACTERISTICS										
Electric power (Pel max heating - Pel max DHW)	W	73-87			74-87			87-110		
Electric power burner P max	W	44			44			67		
Electric power circulating unit max	W	43			43			43		
Electric power circulating unit min	W	4			4			4		
Power supply voltage	V - Hz	230-50			230-50			230-50		
Protection level	IP	X5D			X5D			X5D		
HEATING OPERATION										
Maximum pressure	bar	3			3			3		
Minimum pressure for standard operation	bar	0,25÷0,45			0,25÷0,45			0,25÷0,45		
Maximum temperature	°C	90			90			90		
Selection field of heating water temperature.	°C	20/45 - 40/80			20/45 - 40/80			20/45 - 40/80		
Pump: max discharge head available to the system at a flow rate of	mbar	450			450			450		
Membrane expansion tank	l	9			9			9		
Expansion tank pre-charge	bar	1			1			1		

DESCRIPTION	U.M.	RESIDENCE HM								
		25 KIS			30 KIS			35 KIS		
DHW OPERATION - INSTANTANEOUS VERSION										
Maximum pressure	bar	8			8			8		
Minimum pressure	bar	0,5			0,5			0,5		
Quantity of hot water with Dt 25°C	l/min	14,3			17,2			20		
with Dt 30°C	l/min	11,9			14,3			16,7		
with Dt 35°C	l/min	10,2			12,3			14,3		
DHW minimum output	l/min	2			2			2		
Selection field of DHW water temperature.	°C	37/60			37/60			37/60		
Flow regulator	l/min	10			12			14		
AIR AND FLUE GASES FLOW RATES										
Heating		G20	G230	G31	G20	G230	G31	G20	G230	G31
Air flow rate	Nm ³ /h	24,8	24,1	24,8	31,0	29,3	31,3	37,2	35,2	37,6
Flue gas flow rate	Nm ³ /h	26,8	26,5	26,4	33,5	32,2	33,3	40,2	38,7	39,9
Mass flue gas flow rate (max-min)	g/s	9,267- 1,158	9,327- 1,166	9,297- 1,162	11,584- 1,390	11,355- 1,363	11,726- 1,627	13,900- 1,622	13,625- 1,590	14,072- 1,627
DHW										
Air flow rate	Nm ³ /h	31,0	30,2	31,0	37,2	35,2	37,6	43,3	40,9	43,7
Flue gas flow rate	Nm ³ /h	33,513	33,068	32,963	40,216	38,622	39,908	46,784	44,976	46,426
Mass flue gas flow rate (max-min)	g/s	11,584- 1,158	11,658- 1,166	11,621- 1,162	13,900- 1,390	13,625- 1,363	14,072- 1,627	16,171- 1,622	15,851- 1,590	16,370- 1,627
EMISSION VALUES AT MAX AND MIN FLOW RATE WITH GAS (**)										
Maximum										
CO s.a. lower than	p.p.m	230	200	250	200	230	250	240	230	240
CO ₂	%	8,8	10,0	10,0	8,8	10,3	9,9	8,8	10,3	9,9
Nox s.a. lower than	p.p.m	40	25	50	30	30	40	30	30	40
Flue gas temperature	°C	79	75	78	71	71	70	82	71	70
Minimum										
CO s.a. lower than	p.p.m	15	20	20	15	25	20	15	25	20
CO ₂	%	8,8	10,0	10,0	8,8	10,3	10,0	8,8	10,3	10
Nox s.a. lower than	p.p.m	30	25	50	30	30	40	30	30	40
Flue gas temperature	°C	60	66	60	57	63	57	60	63	57

NOTE

(*) Average value of the various operating conditions in DHW mode

(**) Check performed with concentric pipe Ø60-100mm, length 0,85 m - water temperature 80-60°C

The data in the grey boxes are to be used for the telematic mailing to ENEA for tax relief purposes

CONDENSING BOILERS

Wall-hung condensing boilers

RESIDENCE HM IS

DESCRIPTION	U.M.	RESIDENCE HM					
		20 IS			30 IS		
Gas category		I12HY20M3P			I12HY20M3P		
Country of destination		IT			IT		
Flue gas exhaust installation type		B23P; B53P; C(10); C13,C13x; C33,C33x; C43,C43x; C53,C53x; C63,C63x; C83,C83x,C93,C93x			B23P; B53P; C(10); C13,C13x; C33,C33x; C43,C43x; C53,C53x; C63,C63x; C83,C83x,C93,C93x		
HEATING		G20	G230	G31	G20	G230	G31
Nominal heat input (Hi)	kW	20,00			30,00		
Nominal heat output (80-60 °C)	kW	19,53			29,28		
Nominal heat output (50-30 °C)	kW	21,31			31,75		
Reduced heat input (Hi)	kW	2,50	3,50	-	3,50	4,20	-
Reduced heat output (80-60 °C)	kW	2,34	-	-	3,36	-	-
Reduced heat output (50-30 °C)	kW	2,57	-	-	3,71	-	-
DHW							
Nominal heat input (Hi)	kW	20,00			34,90	32,00	-
Nominal heat output (*)	kW	20,00			34,90		
Reduced heat input (Hi)	kW	2,50	3,50	-	3,50	4,20	-
Reduced heat output (*)	kW	2,50	-	-	3,50	-	-
Modulating ratio	-	1:8			1:10		
EFFICIENCY							
Useful efficiency Pn max (80-60 °C)	%	97,7			97,6		
Useful efficiency Pn min (80-60 °C)	%	93,5			96,0		
Useful efficiency Pn max (50-30 °C)	%	106,5			105,8		
Useful efficiency Pn min (50-30 °C)	%	102,9			106,0		
Useful efficiency 30 % (return 30 °C)	%	109,7			109,7		
Stack leaks with burner on (Pn max)	%	2,04			2,17		
Chimney and skirt losses with burner off	%	0,09			0,07		
Casing leaks with burner on (Pn max)	%	0,30			0,20		
FLUE GAS EXHAUST							
Nox class - UNI EN 15502		6			6		
Residual discharge head concentric pipes 0,85 m Ø 60-100 mm	Pa	60			60		
Residual discharge head separate pipes 0,5 m Ø 80 mm	Pa	180			195		
Residual discharge head boiler without pipes max. output.	Pa	186			199		
Residual discharge head boiler without pipes min. output.	Pa	50			50		
ELECTRICAL CHARACTERISTICS							
Electric power (Pel max heating - Pel max DHW)	W	73-73			87-110		
Electric power burner P max	W	44			67		
Electric power circulating unit max	W	43			43		
Electric power circulating unit min	W	4			4		
Power supply voltage	V - Hz	230-50			230-50		
Protection level	IP	X5D			X5D		
HEATING OPERATION							
Maximum pressure	bar	3			3		
Minimum pressure for standard operation	bar	0,25÷0,45			0,25÷0,45		
Maximum temperature	°C	90			90		
Selection field of heating water temperature.	°C	20/45 - 40/80			20/45 - 40/80		
Pump: max discharge head available to the system	mbar	450			450		
at a flow rate of	l/h	1000			1000		
Membrane expansion tank	l	9			9		
Expansion tank pre-charge	bar	1			1		

DESCRIPTION	UM	RESIDENCE HM					
		20 IS			30 IS		
AIR AND FLUE GASES FLOW RATES							
Heating		G20	G230	G31	G20	G230	G31
Air flow rate	Nm ³ /h	24,804	23,889	24,936	37,206	35,16	37,581
Flue gas flow rate	Nm ³ /h	26,811	26,223	26,487	40,216	38,662	39,908
Mass flue gas flow rate (max-min)	g/s	9,267-1,158	9,244-1,166	9,339-1,166	13,900-1,622	13,625-1,590	14,072-1,627
DHW							
Air flow rate	Nm ³ /h	24,804	23,889	24,936	43,284	40,903	43,719
Flue gas flow rate	Nm ³ /h	26,811	26,223	26,487	46,784	44,976	46,426
Mass flue gas flow rate (max-min)	g/s	9,267-1,158	9,244-1,166	9,339-1,166	16,171-1,622	15,851-1,590	16,370-1,627
EMISSION VALUES AT MAX AND MIN FLOW RATE WITH GAS (**)							
		G20	G230	G31	G20	G230	G31
Maximum							
CO s.a. lower than	p.p.m	220	160	250	240	230	240
CO ₂	%	8,8	10,1	10,0	8,8	10,3	9,9
Nox s.a. lower than	p.p.m	40	25	50	30	30	40
Flue gas temperature	°C	69	66	68	82	71	70
Minimum							
CO s.a. lower than	p.p.m	15	20	20	15	25	20
CO ₂	%	8,8	10,0	10,0	8,8	10,3	10
Nox s.a. lower than	p.p.m	30	25	50	30	30	40
Flue gas temperature	°C	60	66	60	60	63	57

NOTE

(*) Average value of the various operating conditions in DHW mode

(**) Check performed with concentric pipe Ø60-100mm, length 0,85 m - water temperature 80-60°C

The data in the grey boxes are to be used for the telematic mailing to ENEA for tax relief purposes

CONDENSING BOILERS

Wall-hung condensing boilers

ERP TECHNICAL DATA

RESIDENCE HM KIS

PARAMETER DESCRIPTION	SYMBOL	U.M.	RESIDENCE HM		
			25 KIS	30 KIS	35 KIS
Seasonal space heating efficiency class			A	A	A
Water heating energy efficiency class			A	A	A
Nominal output	Nominal P	kW	20	24	29
Seasonal energy efficiency for heating	η_s	%	94	94	94
EFFECTIVE HEAT OUTPUT					
At nominal heat output and in high temperature mode (*)	P4	kW	19,5	24,4	29,3
At 30% of nominal heat output and in low temperature mode (**)	P1	kW	6,6	8,2	9,9
EFFICIENCY					
At nominal heat output and in high temperature mode (*)	η_4	%	87,9	87,9	87,9
At 30% of nominal heat output and in low temperature mode (**)	η_1	%	98,8	98,7	98,8
AUXILIARIES ELECTRICITY CONSUMPTION					
With full load	elmax	W	30,0	31,1	44,3
With partial load	elmin	W	12,2	13,3	13,6
In standby	PSB	W	3,0	3,0	3,0
OTHER PARAMETERS					
Heat loss in standby mode	Pstby	W	30,0	35,0	35,0
Energy consumption of the pilot light	Pign	W	-	-	-
Yearly energy consumption	QHE	GJ	60	75	90
Sound power level inside	LWA	dB	48	45	47
Nitrogen oxide emissions	NOx	mg/kWh	22	20	35
FOR COMBINED HEATING APPLIANCES					
Declared load profile			XL	XL	XL
Energy efficiency for water heating	η_{wh}	%	85	85	87
Daily electrical energy consumption	Qelec	kWh	0,173	0,138	0,102
Daily fuel consumption	Qfuel	kWh	23,014	23,01	22,524
Annual electrical energy consumption	AEC	kWh	38	30	22
Annual fuel consumption	AFC	GJ	17	17	17

NOTE

(*) High temperature mode: 60°C on return and 80°C on delivery.

(**) Low temperature mode: for condensing boilers 30°C, for low temperature boilers 37°C, for other heating appliances 50°C return temperature.

The data in the grey boxes are to be used for the telematic mailing to ENEA for tax relief purposes

RESIDENCE HM IS

PARAMETER DESCRIPTION	SYMBOL	U.M.	RESIDENCE HM		
			20 IS	30 IS	
Seasonal space heating efficiency class	-	-	A	A	
Water heating energy efficiency class	-	-	-	-	
Nominal output	Nominal P	kW	20	29	
Seasonal energy efficiency for heating	η_s	%	94	94	
EFFECTIVE HEAT OUTPUT					
At nominal heat output and in high temperature mode (*)	P ₄	kW	19,5	29,3	
At 30% of nominal heat output and in low temperature mode (**)	P ₁	kW	6,6	9,9	
EFFICIENCY					
At nominal heat output and in high temperature mode (*)	η_4	%	87,9	87,9	
At 30% of nominal heat output and in low temperature mode (**)	η_1	%	98,8	98,8	
AUXILIARIES ELECTRICITY CONSUMPTION					
With full load	elmax	W	30,0	44,3	
With partial load	elmin	W	12,2	13,6	
In standby	PSB	W	3,0	3,0	
OTHER PARAMETERS					
	30,0	35,0	W	29,9	35,2
	-	-	W	-	-
	60	90	GJ	60	91
	48	47	dB	48	47
	22	35	mg/kWh	22	35
FOR COMBINED HEATING APPLIANCES					
Declared load profile	-	-	-	-	
Energy efficiency for water heating	η_{wh}	%	-	-	
Daily electrical energy consumption	Q _{elec}	kWh	-	-	
Daily fuel consumption	Q _{fuel}	kWh	-	-	
Annual electrical energy consumption	AEC	kWh	-	-	
Annual fuel consumption	AFC	GJ	-	-	

NOTE

(*) High temperature mode: 60°C on return and 80°C on delivery.

(**) Low temperature mode: for condensing boilers 30°C, for low temperature boilers 37°C, for other heating appliances 50°C return temperature.

The data in the grey boxes are to be used for the telematic mailing to ENEA for tax relief purposes

CONDENSING BOILERS

Wall-hung condensing boilers

TABLE LAW10

RESIDENCE HM KIS

BOILER MODELS	U.M.	RESIDENCE HM								
		25 KIS			30 KIS			35 KIS		
MAXIMUM HEAT OUTPUT										
Effective (80-60 °C)	kW	19,53			24,42			29,28		
Effective (50-30 °C)	kW	21,31			26,51			31,75		
Furnace	kW	20,00			25,00			30,00		
MINIMUM HEAT OUTPUT										
Effective (80-60 °C)	kW	2,34			2,87			3,36		
Effective (50-30 °C)	kW	2,57			3,19			3,71		
Furnace	kW	2,50			3,00			3,50		
EFFICIENCY										
Useful efficiency Pn max - Pn min (80-60 °C)	%	97,7			97,7			97,6		
Useful efficiency Pn max - Pn min (50-30 °C)	%	106,5			106			105,8		
Useful efficiency 30 % (return 30 °C)	%	109,7			109,6			109,7		
Stack leaks with burner on (Pn max)	%	2,04			2,07			2,17		
Chimney and skirt losses with burner off		0,09			0,08			0,07		
Casing leaks with burner on (Pn max)	%	0,3			0,2			0,2		
EMISSION VALUES AT MAX AND MIN FLOW RATE WITH GAS (*)										
Maximum										
CO s.a. lower than	p.p.m	230	200	250	200	230	250	240	230	240
CO ₂	%	8,8	10	10	8,8	10,3	9,9	8,8	10,3	9,9
Nox s.a. lower than	p.p.m	40	25	50	30	30	40	30	30	40
Flue gas temperature	°C	79	75	78	71	71	70	82	71	70
Minimum										
CO s.a. lower than	p.p.m	15	20	20	15	25	20	15	25	20
CO ₂	%	8,8	10	10	8,8	10,3	10	8,8	10,3	10
Nox s.a. lower than	p.p.m	30	25	50	30	30	40	30	30	40
Flue gas temperature	°C	60	66	60	57	63	57	60	63	57
Nox class		6			6			6		
Electric power (Pel max heating -Pel max DHW)	W	73-87			74-87			87-110		

(*) Check performed with concentric pipe Ø60-100mm, length 0,85 m; water temperature 80-60°C.

RESIDENCE HM IS

BOILER MODELS	U.M.	RESIDENCE HM					
		20 IS			30 IS		
MAXIMUM HEAT OUTPUT							
Effective (80-60 °C)	kW	19,53			29,28		
Effective (50-30 °C)	kW	21,31			31,75		
Furnace	kW	20,00			30,00		
MINIMUM HEAT OUTPUT							
Effective (80-60 °C)	kW	2,34			3,36		
Effective (50-30 °C)	kW	2,57			3,71		
Furnace	kW	2,5			3,5		
EFFICIENCY							
Useful efficiency Pn max - Pn min (80-60 °C)	%	97,7			97,6		
Useful efficiency Pn max - Pn min (50-30 °C)	%	106,5			105,8		
Useful efficiency 30 % (return 30 °C)	%	109,7			109,7		
Stack leaks with burner on (Pn max)	%	2,04			2,17		
Chimney and skirt losses with burner off		0,09			0,07		
Casing leaks with burner on (Pn max)	%	0,3			0,2		
EMISSION VALUES AT MAX AND MIN FLOW RATE WITH GAS (*)							
Maximum							
CO s.a. lower than	p.p.m	220	160	250	240	230	240
CO ₂	%	8,8	10,1	10	8,8	10,3	9,9
Nox s.a. lower than	p.p.m	40	25	50	30	30	40
Flue gas temperature	°C	69	66	68	82	71	70
Minimum							
CO s.a. lower than	p.p.m	15	20	20	15	25	20
CO ₂	%	8,8	10	10	8,8	10,3	10
Nox s.a. lower than	p.p.m	30	25	50	30	30	40
Flue gas temperature	°C	60	66	60	60	63	57
Nox class	-	6			6		
Electric power (Pel max heating - Pel max DHW)	W	73-73			87-110		

(*) Check performed with concentric pipe Ø60-100mm, length 0,85 m; water temperature 80-60°C.

CONDENSING BOILERS

Wall-hung condensing boilers

DETERMINATION OF GENERATION LOSSES – CALCULATION METHOD DIRECTIVE 92/42 EEC – DATA 11300-2

RESIDENCE HM KIS

PARAMETER DESCRIPTION	SYMBOL	UM	RESIDENCE HM		
			25 KIS	30 KIS	35 KIS
Useful nominal heat output	Fgn,Pn	kW	19,53	24,42	29,28
Efficiency at nominal output	hgn,pn	%	97,7	97,7	97,6
Average temperature at Pn	qgn,test,pn	°C	70	70	70
Useful heat output at 30%	Fint	kW	2,50	3,00	3,50
Output efficiency 30%	hgn,Pint	%	109,7	109,6	109,7
Average temperature at intermediate P	qgn,test,Pint	°C	40	40	40
Power lost at zero load with Dqgn,test	Fgn,1,P0	W	30	35	35
Auxiliary power consumption at nominal load	Wgn,aux,Pn	W	30	31,1	44,3
Auxiliary power consumption at intermediate load	Wgn,aux,Pint	W	12,2	13,3	13,6
Auxiliary power consumption at zero load	Wgn,aux,P0	W	3	3	3
Generator minimum return temperature	qgn,min	°C	20	20	20

RESIDENCE HM IS

PARAMETER DESCRIPTION	SYMBOL	UM	RESIDENCE HM	
			20 IS	30 IS
Useful nominal heat output	Fgn,Pn	kW	19,53	29,28
Efficiency at nominal output	hgn,pn	%	97,7	97,6
Average temperature at Pn	qgn,test,pn	°C	70	70
Useful heat output at 30%	Fint	kW	2,50	3,50
Output efficiency 30%	hgn,Pint	%	109,7	109,7
Average temperature at intermediate P	qgn,test,Pint	°C	40	40
Power lost at zero load with Dqgn,test	Fgn,1,P0	W	30	35
Auxiliary power consumption at nominal load	Wgn,aux,Pn	W	30	44,3
Auxiliary power consumption at intermediate load	Wgn,aux,Pint	W	12,2	13,6
Auxiliary power consumption at zero load	Wgn,aux,P0	W	3	3
Generator minimum return temperature	qgn,min	°C	20	20

CIRCULATOR RESIDUAL DISCHARGE HEAD

The boiler is fitted with a high-efficiency circulator already hydraulically and electrically connected. The relative usable performance values are shown in the chart.

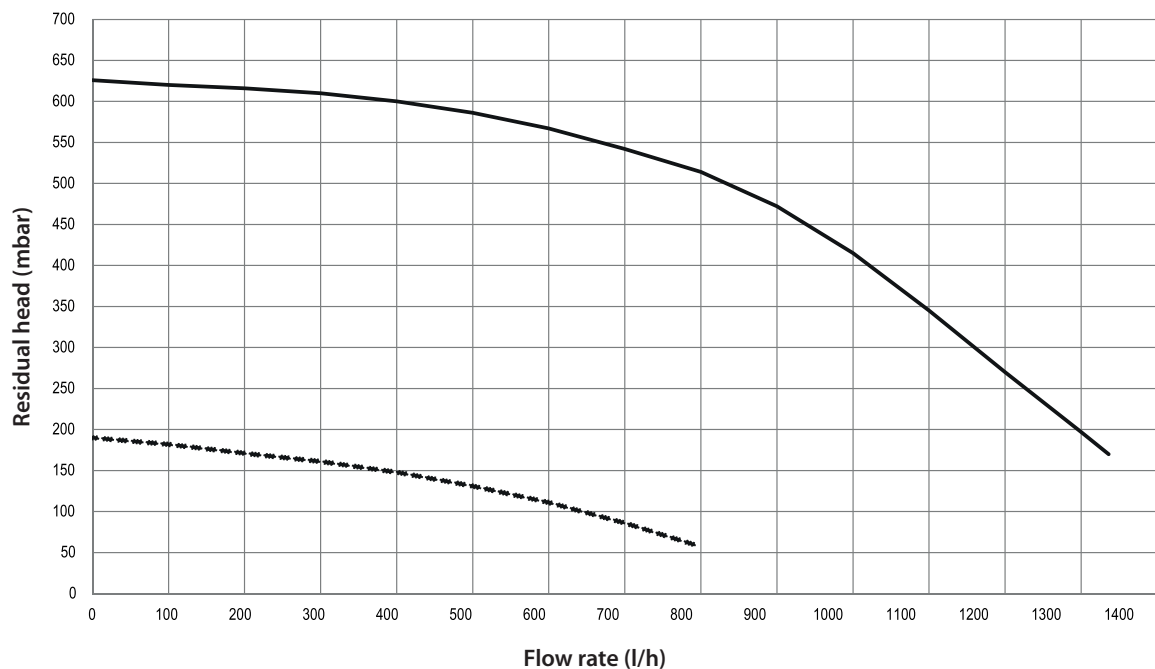

WATER CHARACTERISTICS

PARAMETERS	U.M.	HEATING CIRCUIT WATER	FILLING WATER
pH value	-	7-8	-
Hardness	°F	-	<15
Appearance	-	-	clear
Fe	mg/ kg	<0,5	-
Cu	mg/ kg	<0,1	-

In the case of a new installation or replacement of the boiler, it is necessary to clean the heating system. To ensure the device works well, top up the additives and/or chemical treatments (e.g. anti-freeze liquids, filming agents, etc.) and check the parameters in the table are within the values indicated.

CONDENSING BOILERS

Wall-hung condensing boilers

DIMENSIONS

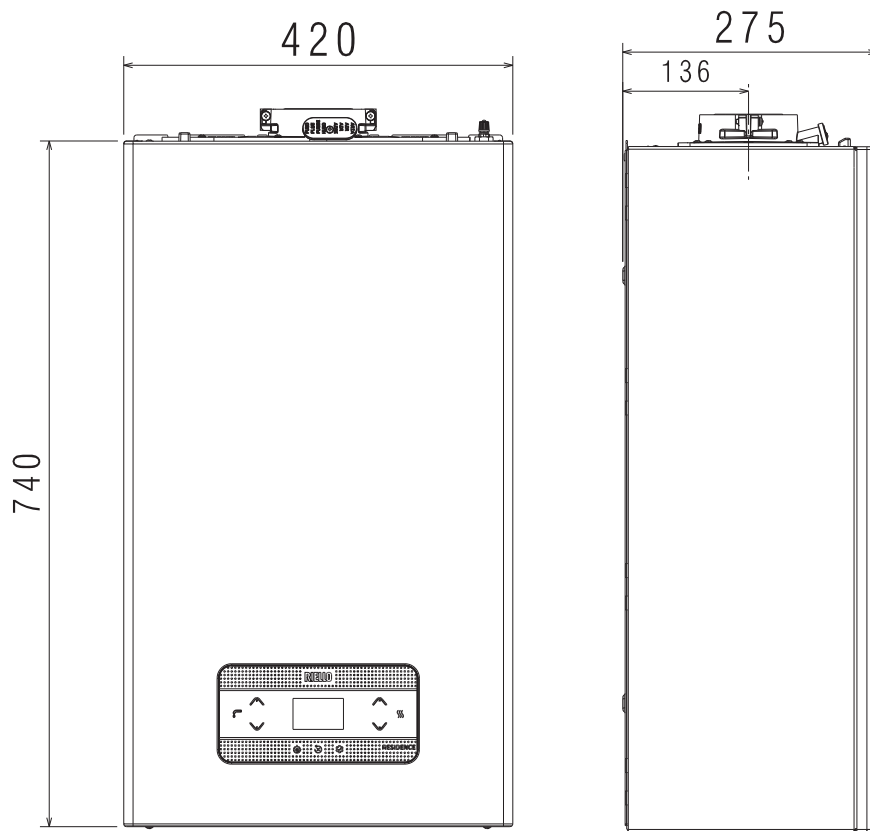

MODELS	RESIDENCE HM					
	25 KIS	30 KIS	35 KIS	20 IS	30 IS	
Weight	kg	29	30	30	28	29

PLACE OF INSTALLATION

This type C condensing boiler is designed for heating and DHW production and, depending on the type of installation, falls into two categories:

- 1 Boiler type B23P-B53P: forced open installation, with flue gases discharge pipe and combustion air intake from the installation area. If the boiler is not installed outdoors, an air intake point in the installation area is compulsory;
- 2 Type C boiler C(10)3; C13, C13x; C33, C33x; C43, C43x; C53, C53x; C63, C63x; C83, C83x; C93, C93x: sealed chamber appliance with smoke evacuation pipe and combustion air intake from outside. An air intake point in the installation area is not required.

The appliance can be installed indoors (fig. A) or outdoors, but in a partially protected place (fig. B) where it is not directly exposed to the infiltration of rain, snow or hail.

The temperature range in which it can operate is $>0^{\circ}\text{C}$ to $+60^{\circ}\text{C}$.

The boiler can also be installed outdoors in the built-in unit (fig. C - please refer to the specific kit for dedicated instructions).

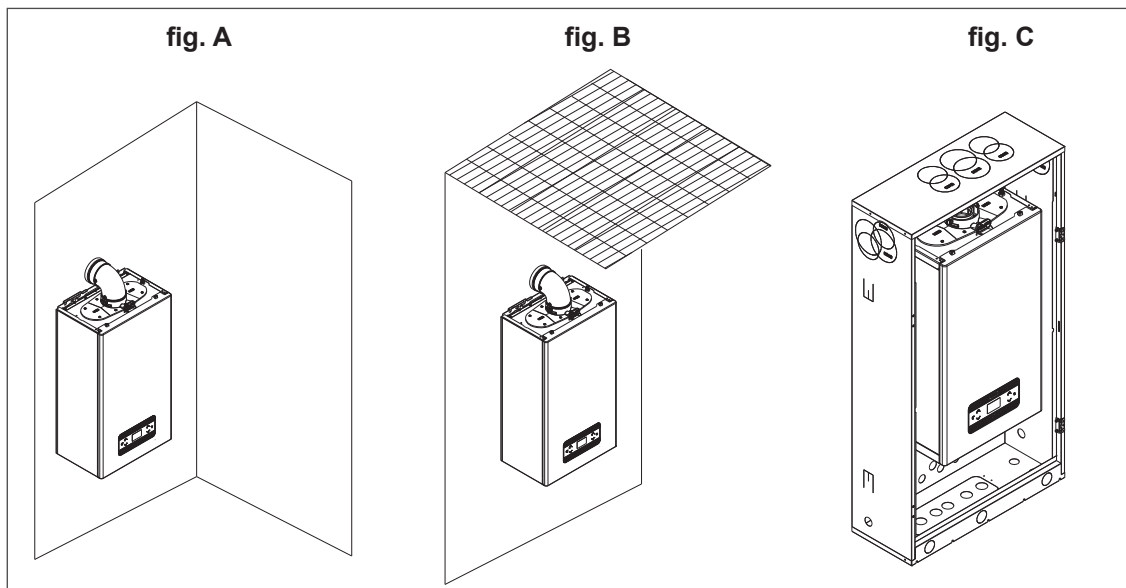
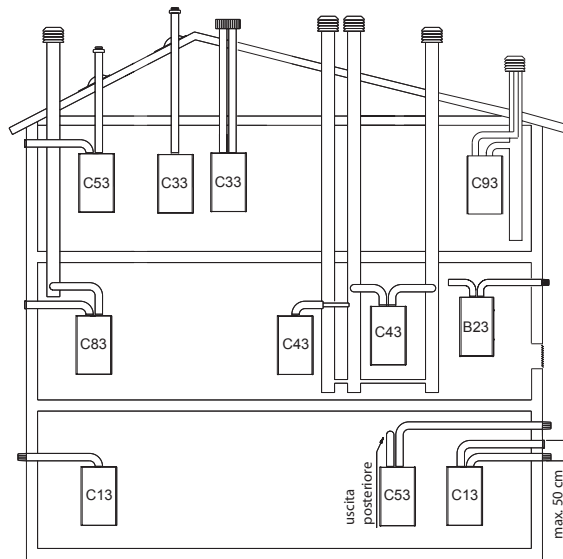

CONDENSING BOILERS

Wall-hung condensing boilers

ANTI-FREEZE SYSTEM

The boiler comes as standard with an automatic anti-freeze system, which activates when the temperature of the primary circuit water drops below 5°C. This system is always active and provides protection for the boiler up to an air temperature in the installation area of >0°C.

NOTE

Refer to the installation manual for more information.

MINIMUM TECHNICAL SPACES

Access the inside of the boiler for routine maintenance tasks, respecting the minimum installation clearances. When positioning the appliance, bear in mind that:

- it must be installed on a wall that can support its weight
- it must not be placed above a cooker or other cooking device
- it is forbidden to leave flammable products in the room where the boiler is installed

MINIMUM TECHNICAL SPACES FOR MAINTENANCE

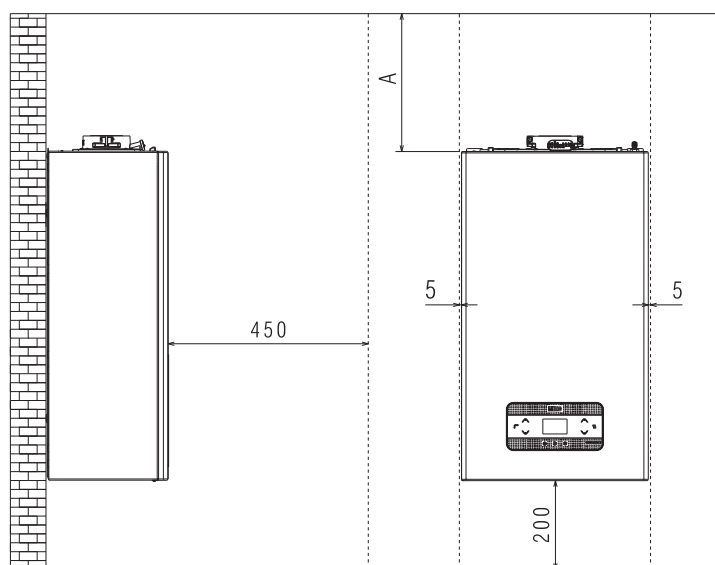

NOTE

(A) see section "Configuration of flue gases discharge" measurements in mm

MINIMUM TECHNICAL SPACES FOR CABINET INSTALLATION

Observe a safe distance between the wall on which the boiler is installed and hot parts outside it.

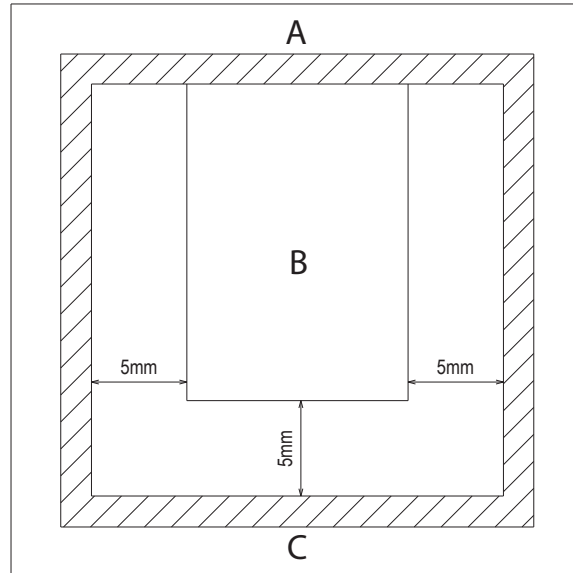

NOTE
(A) Rear
(B) View from above
(C) Cabinet installation

CONDENSING BOILERS

Wall-hung condensing boilers

STRUCTURE

RESIDENCE HM KIS

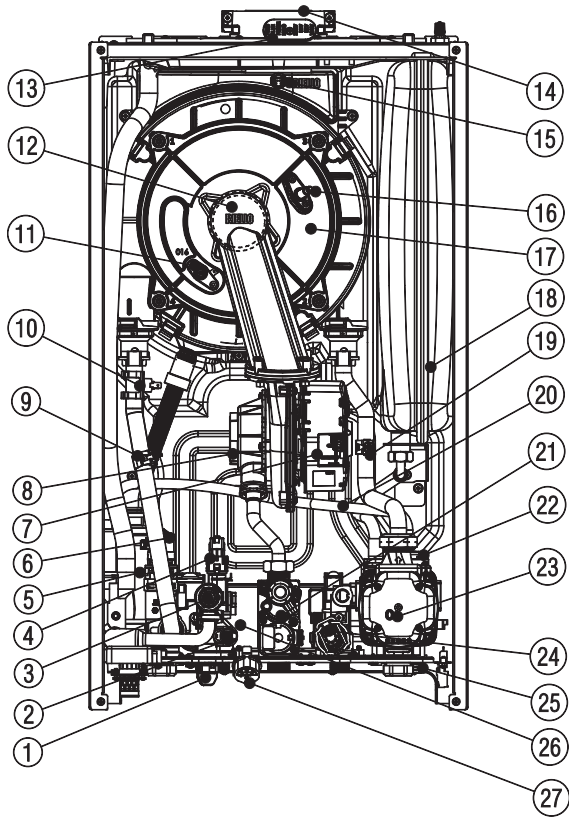

- 1 Filling valve
- 2 Domestic hot water NTC probe
- 3 Safety valve
- 4 Pressure transducer
- 5 Siphon
- 6 3-way valve
- 7 Fan
- 8 Mixer
- 9 Flow NTC delivery probe
- 10 Limit thermostat
- 11 Flame detection electrode/ionisation sensor
- 12 Burner
- 13 Combustion analysis socket plug
- 14 Flue gas exhaust
- 15 Flue gas probe
- 16 Flame ignition electrode
- 17 Heat exchanger
- 18 Expansion vessel
- 19 Return NTC probe
- 20 Degassing unit pipe
- 21 Gas valve
- 22 Air vent valve
- 23 Circulator
- 24 Flow meter
- 25 System discharge tap
- 26 DHW heat exchanger
- 27 Hydrometer

RESIDENCE HM IS

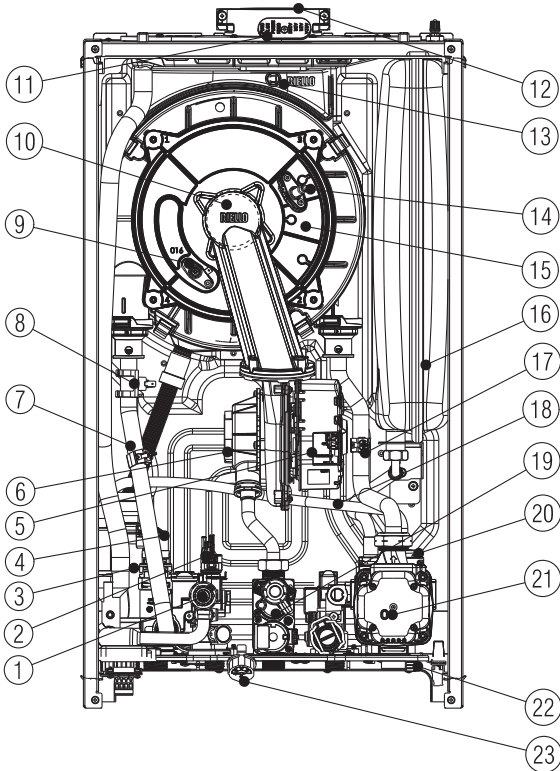

- 1 Safety valve
- 2 Pressure transducer
- 3 Siphon
- 4 3-way valve
- 5 Fan
- 6 Mixer
- 7 Flow NTC probe
- 8 Limit thermostat
- 9 Flame detection electrode/ionisation sensor
- 10 Burner
- 11 Combustion analysis socket plug
- 12 Flue gas exhaust
- 13 Flue gas probe
- 14 Flame ignition electrode
- 15 Heat exchanger
- 16 Expansion vessel
- 17 Return NTC probe
- 18 Degassing unit pipe
- 19 Gas valve
- 20 Air vent valve
- 21 Circulator
- 22 System discharge tap
- 23 Hydrometer

CONDENSING BOILERS

Wall-hung condensing boilers

INSTALLATION TEMPLATE AND HYDRAULIC CONNECTIONS

RESIDENCE HM KIS

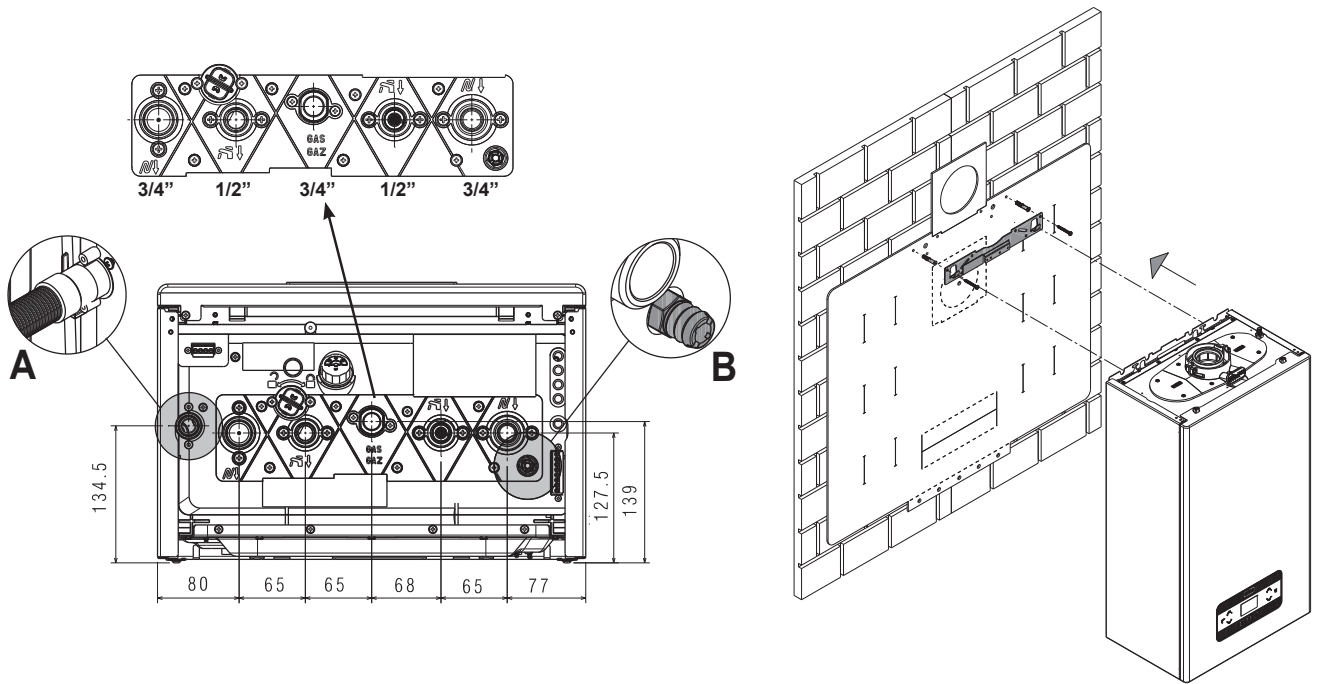

(A) drain-trap safety valve

(B) system discharge tap

DESCRIPTION	Gasket	Torque wrench
Tightening torque	Ø 3/4"	35Nm
	Ø 1/2"	25Nm

RESIDENCE HM IS

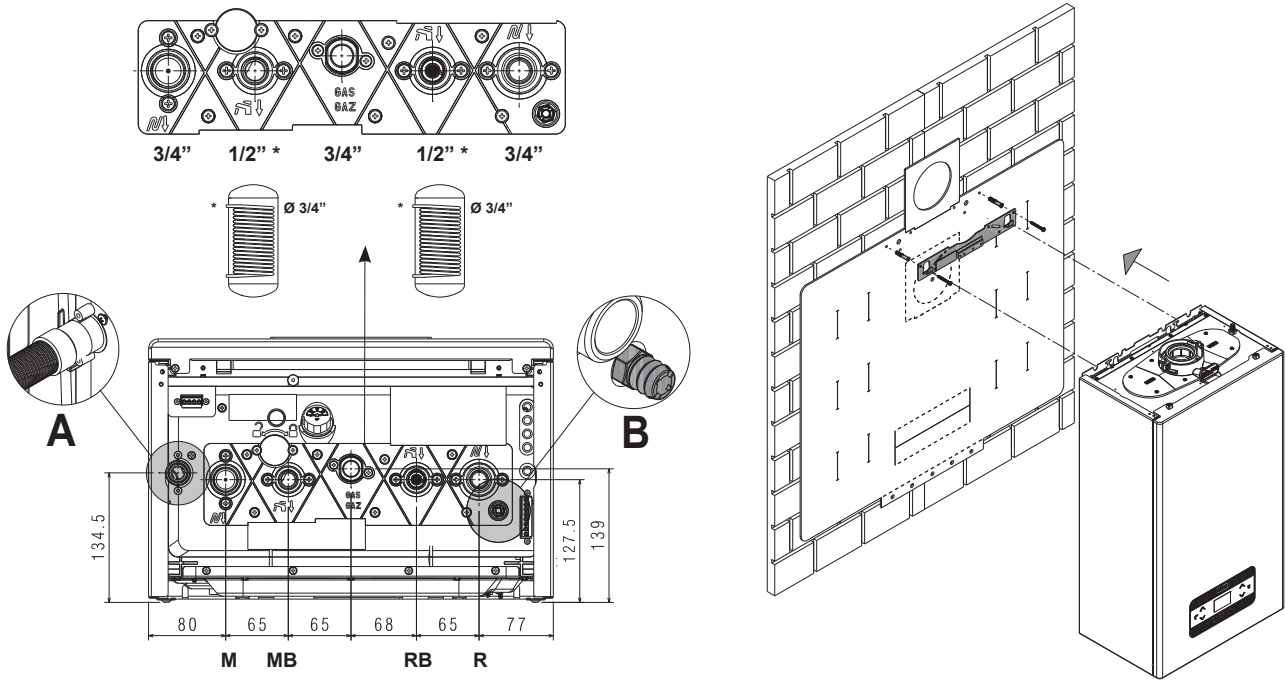

- (A) drain-trap safety valve
- (B) system discharge tap

NOTE

If a cylinder is not connected, it is mandatory to connect to each other supply and return of the cylinder, using an appropriate fitting.

DESCRIPTION	Gasket	Torque wrench
Tightening torque	Ø 3/4"	35Nm
	Ø 1/2"	25Nm

CONDENSING BOILERS

Wall-hung condensing boilers

HYDRAULIC CIRCUIT

RESIDENCE HM KIS

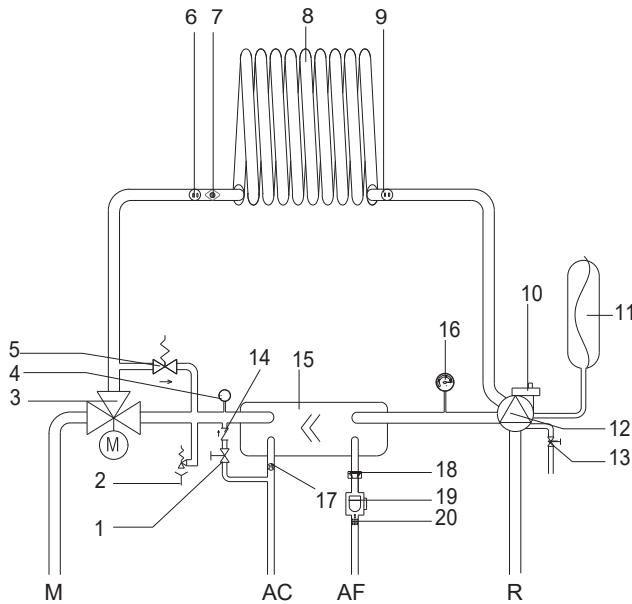

- AC Hot water
- AF Cold water
- M Heating flow
- R Heating return
- 1 Safety valve
- 2 Safety valve
- 3 Hydraulic 3-way valve
- 4 Pressure transducer
- 5 Automatic bypass
- 6 Flow probe
- 7 Limit thermostat
- 8 Primary heat exchanger
- 9 Return probe
- 10 Lower air vent valve
- 11 Expansion vessel
- 12 Circulator
- 13 System discharge tap
- 14 Non-return valve
- 15 DHW heat exchanger
- 16 Hydrometer
- 17 DHW probe
- 18 Flow limiter
- 19 Flow meter
- 20 DHW filter

RESIDENCE HM IS

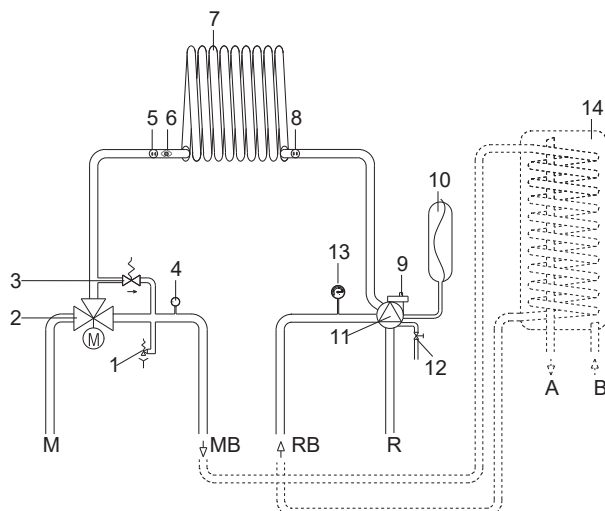

- M Heating flow
- R Heating return
- MB DHW tank flow
- RB DHW tank return
- A Hot water outlet
- B Cold water inlet
- 1 Filling valve
- 2 Hydraulic 3-way valve
- 3 Automatic bypass
- 4 Pressure transducer
- 5 Flow probe
- 6 Limit thermostat
- 7 Primary heat exchanger
- 8 Return probe
- 9 Lower air vent valve
- 10 Expansion vessel
- 11 Circulator
- 12 System discharge tap
- 13 Hydrometer
- 14 DHW tank (available by request)

WIRING

ACCESS TO ELECTRICAL PARTS

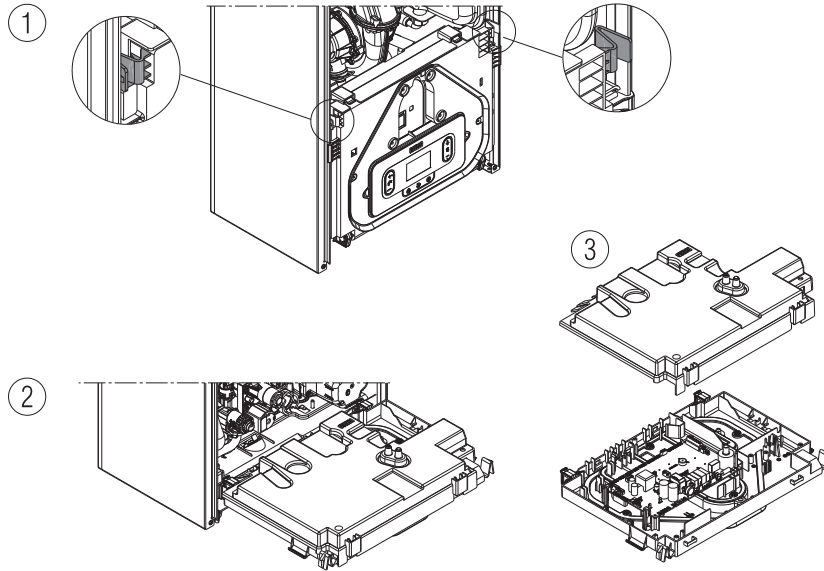

Make the low voltage connections as follows:

- use the connectors supplied:
- ModBus 4-pole connector for the BUS 485 signal (- AB +)
- 8-pole connector for TBT - TA - OT+ - SE signals

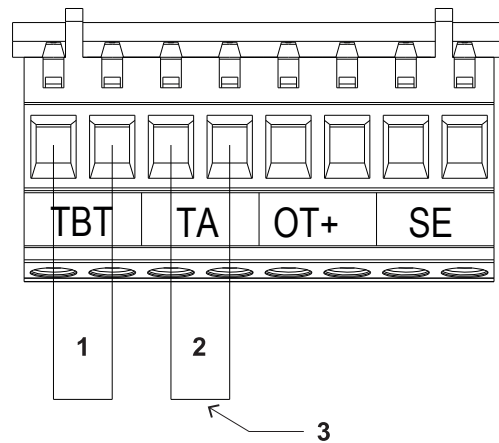
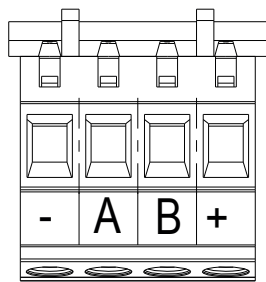

Key	
CE4 (- AB+)	Bus 485
CE8 TBT	Low temperature thermostat
TA	Room thermostat (voltage-free contact)
OT+	Open therm
SE	External probe

NOTE	
(1)	White
(2)	Black
(3)	Use a voltage-free contact

CONDENSING BOILERS

Wall-hung condensing boilers

- make the electrical connections using the desired connector as shown in the detail drawing
- after making the connections, insert the connector in its counterpart

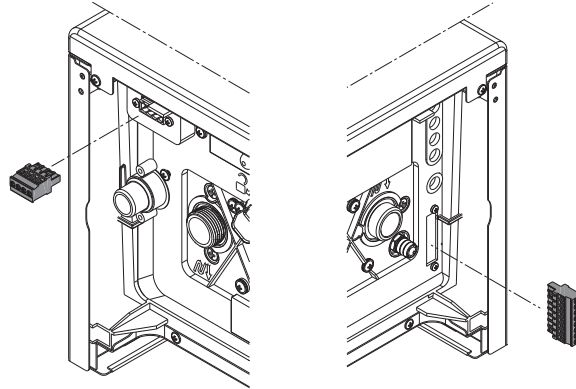

You are advised to use conductors with a cross-section between $0,35\text{mm}^2$ and $1,5\text{mm}^2$.

For the BUS 485 connection, it is recommended to use the shielded cable if the signal passes near other electric wires or mains voltage wires (230V).

In the case of a TA or TBT connection, remove the relative jumpers on the terminal board.

CONTROL PANEL

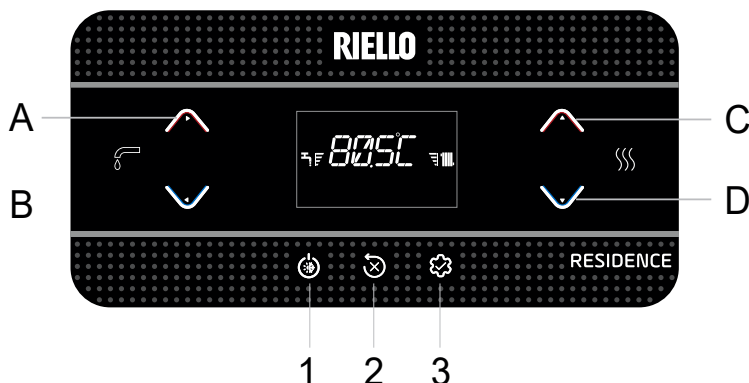

Key	DESCRIPTION
A	Normally used to increase the domestic hot water temperature value, when the arrow is highlighted ► it carries out a confirmation function
B	Normally used to decrease the DHW temperature value, but when the arrow ◀ is highlighted it acts as a back/annul button
C+D	Heating time programming, status change
C	Normally used to increase the heating water temperature value, when highlighted the arrow ▲ allows you to move within the menu P1
D	Normally used to decrease the heating water temperature value, when highlighted the arrow ▼ allows you to move within the menu P1
A+C	Access to the clock setting menu
B+D	Time band programming
1	Used to modify the boiler operating status (OFF, SUMMER and WINTER)
2	Used to reset the alarm status, or to interrupt the venting cycle
3	Used to access menus INFO (press lightly) and P1 (press > 2 sec). When the Enter icon appears on the display, this button has an ENTER function and is used to confirm the value set while programming a technical parameter
1+3	Button lock and release
2+3	Used when the boiler is OFF, to activate the flue gas analysis function (CO)
	Indicates connection to a remote device (OTBus or RS485)
	Indicates connection to a WIFI device
	Indicates the presence of an outdoor temperature sensor
	Indicates the activation of special DHW functions
	Lights up if an alarm is triggered

Key	DESCRIPTION
	Lights up in the event of a fault together with the icon , excluding flame and water alarms
	Indicates presence of a flame, in the event of a flame lockout the icon appears
	Flashes with temporary water alarms, steady with definitive alarms
Reset	Lights up in the presence of alarms requiring manual release by the operator
►	Lights up when confirmation is required
◀	When this icon is active, the "confirm" function of button A is active
▲	When this icon is active, the "back/annul" function of button B is active
▼	When this icon is active, the user can navigate the menu or increase the value of the selected parameter
Enter	When this icon is active, the user can navigate the menu or decrease the value of the selected parameter
	Lights up if heating mode is active; flashes with a heating request in progress
	Lights up if DHW mode is active; flashes with a DHW request in progress
	Indicate the set point level (1 notch minimum value, 4 notches maximum value)
1234567	Indicate the days of the week
AUTO ON	Time band programming
MAN ON	Manual time programming ON
MAN OFF	Manual time programming OFF

CONDENSING BOILERS

Wall-hung condensing boilers

FLUE GAS EXHAUST AND COMBUSTION AIR SUCTION

For evacuation of combustion products refer to the standard UNI7129-7131.

Always comply with the local regulations of the fire brigade and gas company, and with any possible municipal regulations.

It is essential for flue gas evacuation and boiler combustion air transfer that only original pipes are used (apart from type C6, as long as it is certified), and that the connection is made as explained in the instructions supplied with the flue gas accessories.

A single flue can be connected to several appliances provided that every appliance is the condensing type.

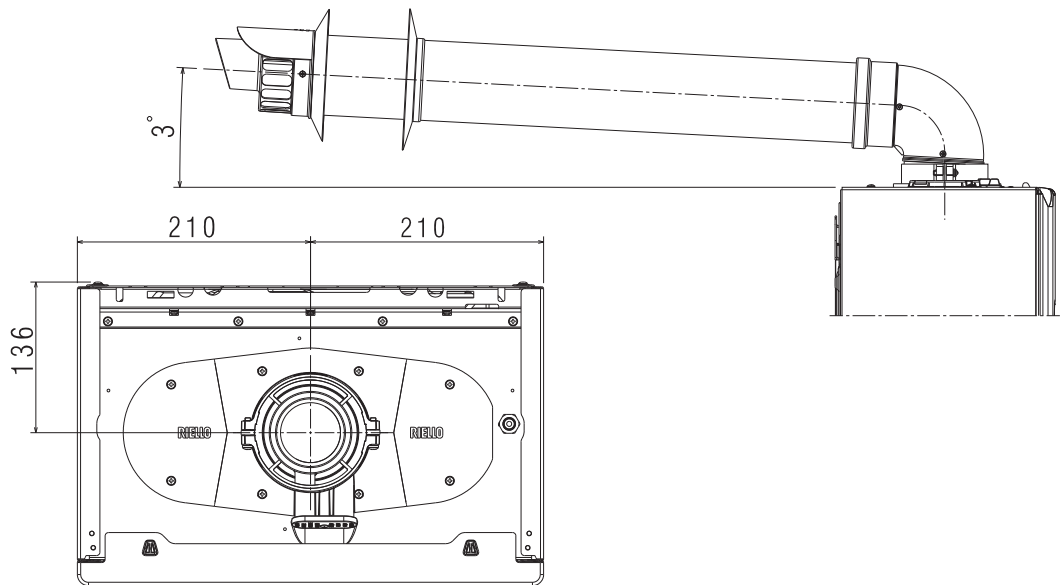

FUME EXHAUST CONFIGURATION

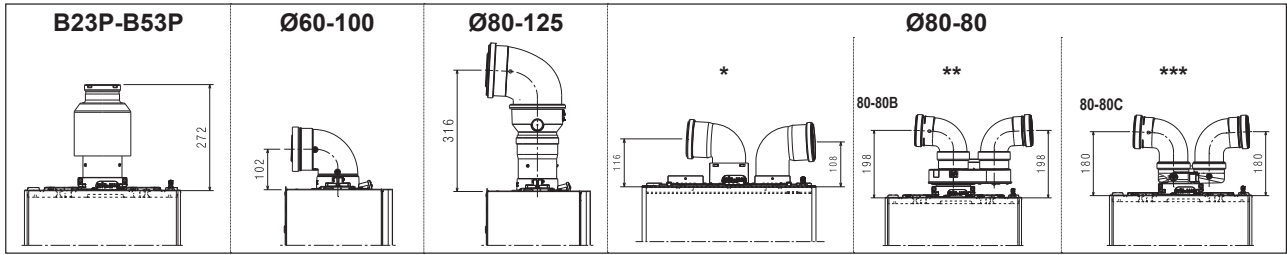

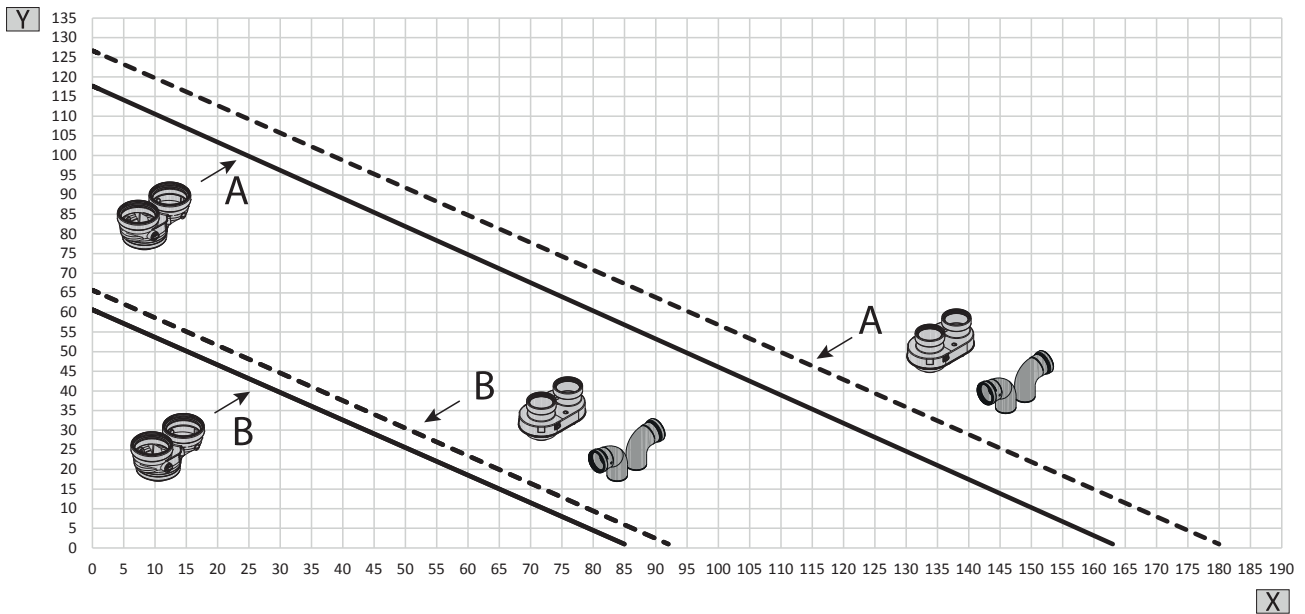

- * twin flue pipe
- ** twin flue pipe from Ø60-100 to Ø80-80
- *** compact twin flue pipe from Ø60-100 to Ø80-80

Max length pipes Ø80-80



(X) Length of air intake pipe (m)
 (Y) Length of exhaust pipe (m)

(A) 25 KIS | 20 IS
 (B) 30 KIS - 35 KIS | 30 IS







PICTURE	DESCRIPTION
	twin flue pipe from Ø60-100 to Ø80-80
	Splitter system using the Ø80 splitter system connection kit (accessory)
	compact twin flue pipe

CONDENSING BOILERS

Wall-hung condensing boilers

FUMES EXHAUST CONFIGURATION TABLE

25 KIS – 30 KIS – 35 KIS

Type of duct		Diameter (Ø - mm)	25 KIS				30 KIS				35 KIS				Pressure drop		Hole in wall (Ø - mm)
			MAX length (m)		MIN length (m)		MAX length (m)		MIN length (m)		MAX length (m)		MIN length (m)		45° bend	90° bend	
	vertical connection from Ø60-100 up to Ø80	80	120		0,50		60		0,50		60		0,50		1	1,5	-
	90° bend Ø60-100	60-100	horiz.	10	horiz.	0,85	horiz.	10	horiz.	0,85	horiz.	10	horiz.	0,85	1,3	1,6	105
			vert.	11	vert.	2	vert.	11	vert.	2	vert.	11	vert.	2			
	90° bend Ø80-125	80-125	25		0,85		20		0,85		20		0,85		1	1,5	130
	adaptor from Ø60-100 to Ø80-125																
	adaptor vertical connection Ø60-100																
	twin flue pipe from Ø60-100 to Ø80-80	80-80	75+75		0,50		39+39		0,50		39+39		0,50		1	1,5	-
	Splitter system using the Ø80 splitter system connection kit (accessory)																
	twin flue pipe from Ø60-100 to Ø80-80	80-80	69+69		0,50		36+36		0,50		36+36		0,50		1	1,5	-

20 IS – 30 IS













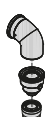



Type of duct		Diameter (Ø - mm)	20 IS				30 IS				Pressure drop		Hole in wall (Ø - mm)
			MAX length (m)		MIN length (m)		MAX length (m)		MIN length (m)		45° bend	90° bend	
	vertical connection from Ø60-100 up to Ø80	80	120		0,50		60		0,50		1	1,5	-
	90° bend Ø60-100	60-100	horiz.	10	horiz.	0,85	horiz.	8	horiz.	0,85	1,3	1,6	105
			vert.	11	vert.	2	vert.	9	vert.	2			
	90° bend Ø80-125	80-125	25		0,85		20		0,85		1	1,5	130
	adaptor from Ø60-100 to Ø80-125												
	adaptor vertical connection Ø60-100												
	twin flue pipe from Ø60-100 to Ø80-80	80-80	75+75		0,50		39+39		0,50		1	1,5	-
	Splitter system using the Ø80 splitter system connection kit (accessory)												
	twin flue pipe da Ø60-100 a Ø80-80	80-80	69+69		0,50		36+36		0,50		1	1,5	-

TABLE OF STANDARD PIPE CONFIGURATIONS (*)

Air suction	1 - 90° bend Ø80
	4,5m pipe Ø80
Flue gas exhaust	1 - 90° bend Ø80
	4,5m pipe Ø80
	Reduction from Ø80 to Ø50 or from Ø80 to Ø60
	90° stack base curve Ø50 or Ø60 or Ø80
	For ducting pipe lengths see table

(*) Use plastic ducting (PP) suitable for condensing boilers and with a pressure class (P1 up to 200 Pa - H1 up to 5000 Pa) suitable for the application, referring to the boiler outlet DP value given in "Regulation tables".

The boilers leave the factory calibrated as follows:

DESCRIPTION		HEAT. rpm	DHW rpm	max length of pipes (m)		
				Ø50	Ø60	Ø80
25 KIS		6300	7900	7	23	116
				6	20	98
30 KIS		6200	7400	2	12	62
				1	11	57
35 KIS		7400	8600	2	12	62
				1	11	57
20 IS		6300	6300	7	23	116
				6	20	98
30 IS		7400	8600	2	12	62
				1	11	57

CONDENSING BOILERS

Wall-hung condensing boilers

Should greater lengths be required, compensate the pressure drop with an increase in the r.p.m. of the fan, as shown in the adjustments table, to provide the rated heat input.

The minimum calibration is not modified.

Tables of adjustments PIPEWORK DUCTS – G20

Models						
	Splitter					
	Fan rotations rpm		Pipes Ø 50	Pipes Ø 60	Pipes Ø 80	P boiler output (Pa)
	Heating	DHW	max. length (m)			
25 KIS	6300	7900	7	23	116	180
	6400	8000	9*	29*	144*	210*
	6500	8100	11*	34*	172*	257*
	6600	8200	14*	40*	201*	285*
	6700	8300	16*	46*	229*	330*
	6800	8400	18*	51*	257*	355*
	6900	8500	21*	57*	285*	385*
	7000	8600	23*	63*	314*	425*
	7100	8700	25*	68*	342*	465*
30 KIS	6200	7400	2	12	62	195
	6300	7500	4*	18*	92*	242*
	6400	7600	6*	24*	119*	289*
	6500	7700	9*	29*	145*	337*
	6600	7800	11*	34*	172*	384*
35 KIS	7400	8600	2	12	62	195
	7500	8700	4*	18*	92*	242*
	7600	8800	6*	24*	119*	289*
	7700	8900	9*	29*	145*	337*
	7800	9000	11*	34*	172*	384*
20 IS	6300	6300	7	23	116	180
	6400	6400	9*	29*	144*	210*
	6500	6500	11*	34*	172*	257*
	6600	6600	14*	40*	201*	285*
	6700	6700	16*	46*	229*	330*
	6800	6800	18*	51*	257*	355*
	6900	6900	21*	57*	285*	385*
	7000	7000	23*	63*	314*	425*
	7100	7100	25*	68*	342*	465*
30 IS	7400	8600	2	12	62	195
	7500	8700	4*	18*	92*	242*
	7600	8800	6*	24*	119*	289*
	7700	8900	9*	29*	145*	337*
	7800	9000	11*	34*	172*	384*

NOTE

(*)Maximum length installable ONLY with class H1 discharge pipes.

Models						
	Compact splitter					
	Fan rotations rpm		Pipes Ø 50	Pipes Ø 60	Pipes Ø 80	P boiler output (Pa)
	Heating	DHW	max. length (m)			
25 KIS	6300	7900	6	20	98	170
	6400	8000	8*	25*	124*	203*
	6500	8100	10*	30*	150*	235*
	6600	8200	13*	35*	176*	268*
	6700	8300	15*	40*	202*	300*
	6800	8400	17*	46*	228*	333*
	6900	8500	19*	51*	253*	365*
	7000	8600	21*	56*	279*	398*
	7100	8700	23*	61*	305*	430*
30 KIS	6200	7400	1	11	57	180
	6300	7500	3*	17*	84*	227*
	6400	7600	6*	22*	111*	274*
	6500	7700	8*	28*	138*	322*
	6600	7800	10*	33*	165*	369*
35 KIS	7400	8600	1	11	57	180
	7500	8700	3*	17*	84*	227*
	7600	8800	6*	22*	111*	274*
	7700	8900	8*	28*	138*	322*
	7800	9000	10*	33*	165*	369*
20 IS	6300	6300	6	20	98	170
	6400	6400	8*	25*	124*	203*
	6500	6500	10*	30*	150*	235*
	6600	6600	13*	35*	176*	268*
	6700	6700	15*	40*	202*	300*
	6800	6800	17*	46*	228*	333*
	6900	6900	19*	51*	253*	365*
	7000	7000	21*	56*	279*	398*
	7100	7100	23*	61*	305*	430*
30 IS	7400	8600	1	11	57	180
	7500	8700	3*	17*	84*	227*
	7600	8800	6*	22*	111*	274*
	7700	8900	8*	28*	138*	322*
	7800	9000	10*	33*	165*	369*

NOTE

(*)Maximum length installable ONLY with class H1 discharge pipes.

The Ø50 or Ø60 or Ø80 configurations contain Lab test data. In the event of installations that differ from the indications in the "standard configurations" and "adjustments" tables, refer to the equivalent linear lengths below. In any case, the maximum lengths declared in the booklet are guaranteed, and it is essential not to exceed them.

COMPONENT	Linear equivalent in metres Ø80 (m)	
	Ø 50	Ø 60
bend 45°	12,3	5
bend 90°	19,6	8
0.5m extension	6,1	2,5
1.0m extension	13,5	5,5
2.0m extension	29,5	12

CONDENSING BOILERS

Wall-hung condensing boilers

SPLITTER SYSTEM USING THE Ø80 SPLITTER SYSTEM CONNECTION KIT (ACCESSORY)

If the Ø60-100 to Ø80-80 splitter kit is used instead of the twin pipe system, there is a loss in the maximum lengths as shown in the table.



SPLITTER KIT	U.M.	Ø 50	Ø 60	Ø 80
Loss of length	m	0,5	1,2	5,5 for flue gas pipe
				7,5 for air pipe

TWIN PIPES WITH Ø 80 PIPEWORK Ø50 - Ø60 - Ø80

Thanks to the boiler characteristics, a Ø80 flue gas discharge pipe can be connected to the Ø50 - Ø60 - Ø80 ducting ranges.

For the ducting, you are advised to make a project calculation in order to respect the relevant standards in force. The table shows the standard configurations allowed.

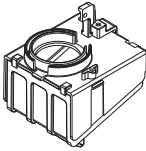
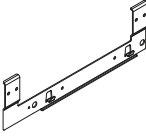
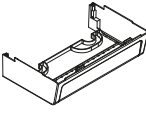
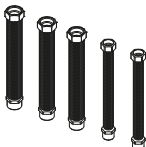
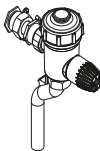
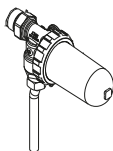
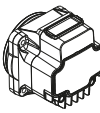
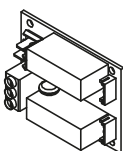
ACCESSORIES

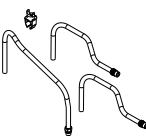
Description	Image
Air filter	
Crossbar for in-wall installation	
Hydraulic low fittings cover	
Flexible fittings kit for boiler replacement	
Compact magnetic filter	
Compact polyphosphate doser kit	
High residual pump 7m	
Board BE09 with double multi-function relay	
Smart key Hi, Comfort K100	
Antifreeze heaters -15 °C	

CONDENSING BOILERS

Wall-hung condensing boilers

BAG³ HYBRID

The BAG³ HYBRID is a hydraulic distributor that can hydraulically separate heat generator circuits from the rest of the heating/cooling system, dividing it into one or two zones.

It should be combined with boilers, heat pumps and additional specific accessories (e.g., storage cylinders, solar modules and panels, etc.) so that hybrid systems can be set up.

It includes a mixing bottle, an electrical box with management boards, one/two low-consumption self-modulating circulators, and a three-way mixing valve that governs the water temperature in the low-temperature zone (1D+1M version).

The hydraulic distributor is to be housed inside the specific box (supplied as an accessory), which can be wall-mounted (indoor installation only) or built-in. Efficient and optimal machine operation even at partial loads.

- BAG³ HYBRID 1D and 2D: for direct systems (1 or 2 zones), can be applied as a hydraulic separator between generators (boiler and heat pump) and system. Equipped with low consumption self-modulating circulators.
- BAG³ HYBRID 1D+1M: for direct and mixed systems, can be applied as a hydraulic separator between generators (boiler and heat pump) and a dual-temperature system. Equipped with low consumption self-modulating circulators. Mixing valve and the mixed circuit pump management is carried out by system intelligence.
- Suitable for recessed or outdoor installation.
- Recessed box made of galvanized sheet metal that can be painted white.
- Hydraulic components supplied already insulated so that they can also be used in the summer cooling phase.
- Electrical and electronic components (circulators, valves, probes, etc.) already pre-wired.
- Possibility of shutting off the system and heat pump with taps that can be installed in the lower part of the box.
- BAG³ HYBRID are equipped as standard with a limit thermostat for low-temperature systems.

TECHNICAL DATA

DESCRIPTION	UM	BAG ³ HYBRID		
		1D	2D	1D+1M
Electrical supply V~Hz 230 (±10%) – 50 Hz	V~Hz	230 (±10%) – 50 Hz		
Maximum absorbed power W 57 114 118	W	57	114	118
Single circulator power output – min / max W 5/52	W	5/52		
Power absorbed by each individual circulation unit – min / max A 0,07/0,52	A	0,07/0,52		
Operating temperature °C 4–90	°C	4–90		
Enclosure electrical protection level °C IP10D	°C	IP10D		
Flush-mounted electrical protection level – IPX5D	-	IPX5D		
Maximum pressure bar 3	bar	3		

STRUCTURE

1 ZONE DIRECT (1D)

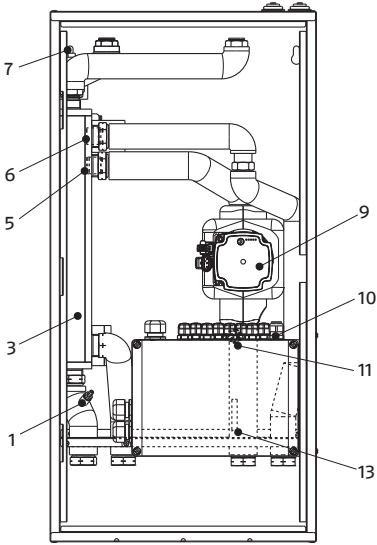

2 ZONE DIRECT (2D)

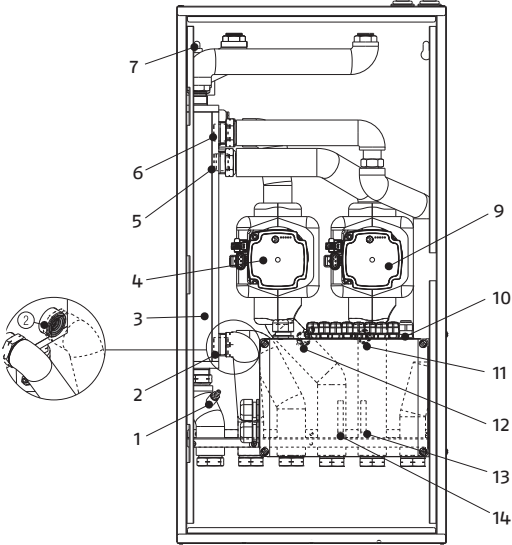

1 ZONE DIRECT + 1 ZONE MIXED (1D+1M)

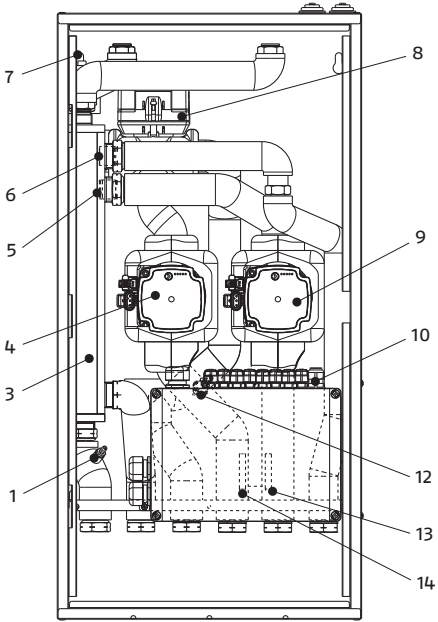

- 1 Drain tap
- 2 Zone 1 (Z1) non-return valve (present only in 2D configuration)
- 3 Mixing bottle
- 4 Zone 1 system circulator (Z1)
- 5 Heat pump circuit non-return valve
- 6 Main zone non-return valve (ZP)
- 7 Air vent valve
- 8 Zone 1 mixing valve (Z1)
- 9 Main zone system circulator (ZP)
- 10 Electric connections box
- 11 Main zone low temperature limit thermostat (ZP) (present only in 1D and 2D configuration)
- 12 Low temperature limit thermostat zone 1 (Z1)
- 13 High temperature system probe main zone (ZP)
- 14 Low temperature system probe zone 1 (Z1)

DIMENSIONS

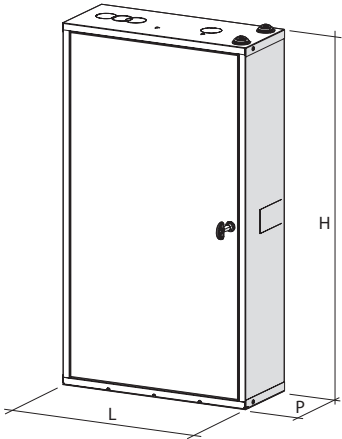

DESCRIPTION	UM	BAG ² HYBRID		
MODEL		1D	2D	1D+1M
L	mm	400	400	400
P	mm	160	160	160
H	mm	797	797	797
Net weightbox	kg	8	8	8
Net weight	kg	13	15	18

CONDENSING BOILERS

Wall-hung condensing boilers

HYDRAULIC CONNECTIONS

Connections can be made directly using the female connections on the delivery and return pipes of BAG³ HYBRID; isolating taps (provided as an optional accessory) can be placed on the connections of the system and the heat pump. These taps are useful during maintenance operations as they allow only the BAG³ HYBRID to be emptied without having to empty the entire system as well.

1 ZONE DIRECT (1D)

2 ZONE DIRECT (2D)

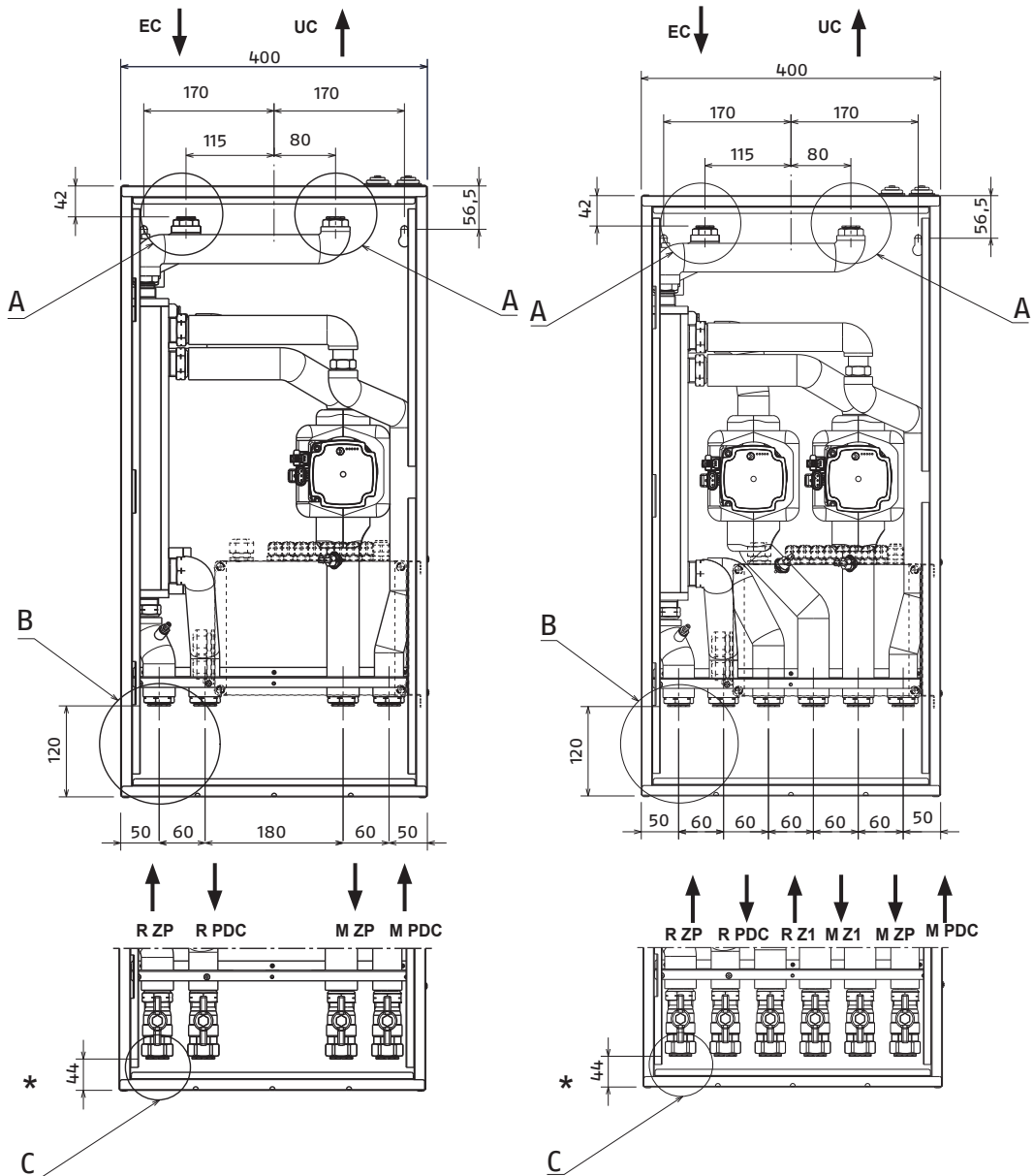

1 ZONE DIRECT + 1 ZONE MIXED (1D+1M)

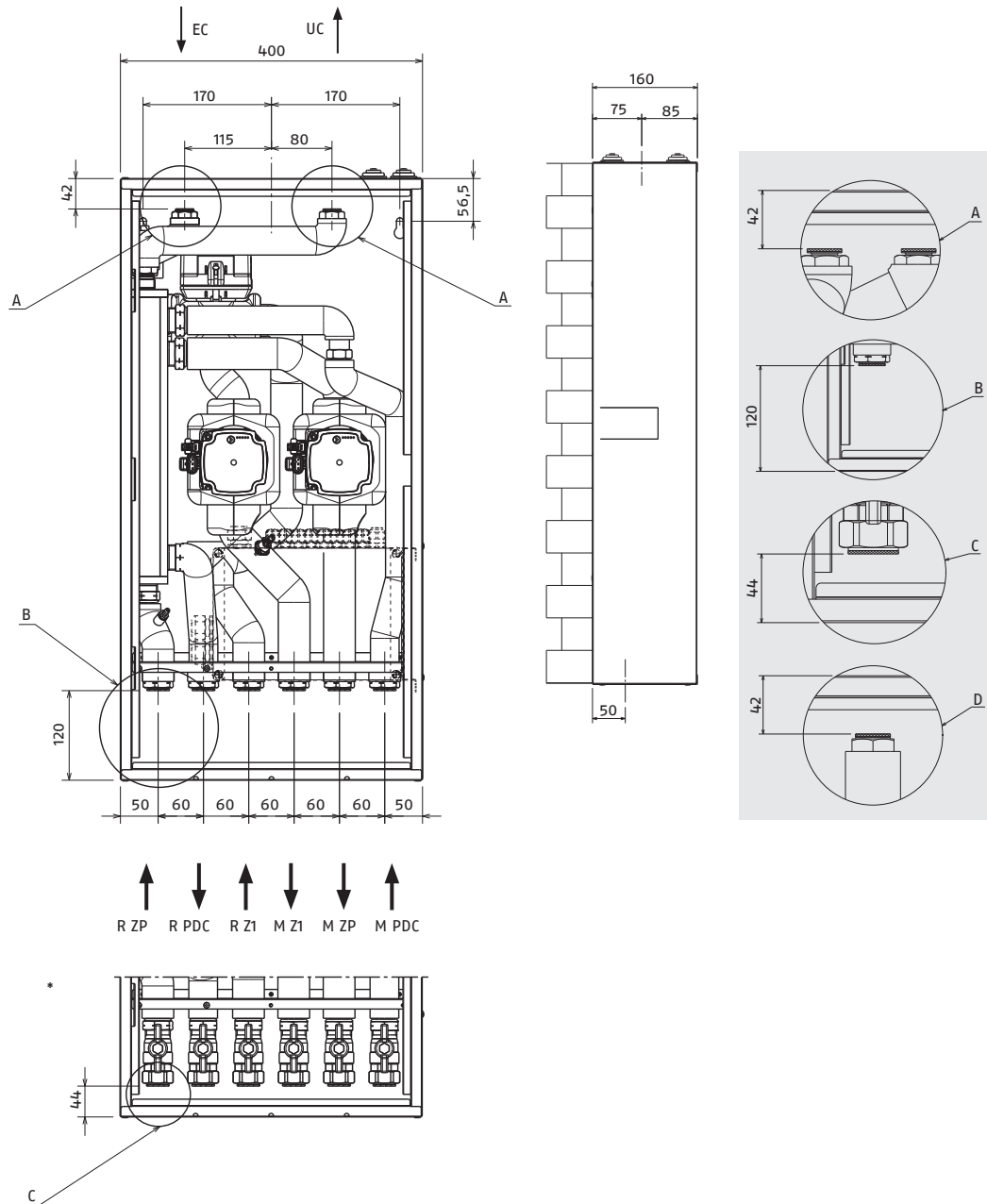

EC Inlet from the boiler (Ø 3/4")

UC Outlet to boiler (Ø 3/4")

UB Outlet to DHW cylinder (Ø 3/4")

M PDC Heat pump flow (Ø 1")

M ZP Main zone flow (Ø 1")

M Z1 Zone 1 flow (Ø 1")

R PDC Return to heat pump (Ø 1")

R ZP Main zone return (Ø 1")

R Z1 Zone 1 return (Ø 1")

* configuration with isolating taps (supplied as an accessory)

CONDENSING BOILERS

Wall-hung condensing boilers

BRIEF DESCRIPTION FOR SPECIFICATIONS

RESIDENCE HM KIS

RESIDENCE HM KIS is a type C condensing boiler designed for heating and the production of domestic hot water and, depending on the type of installation, is identified in two categories:

- B23P-B53P type boiler, forced open installation, with flue gas evacuation duct and combustion air intake from the room in which it is installed. If the boiler is not installed outside, the air intake in the installation room is mandatory;
- type C(10)3 boiler; C13,C13x; C33,C33x; C43,C43x; C53,C53x; C63,C63x; C83,C83x; C93,C93x: sealed chamber appliance with flue gas evacuation duct and combustion air intake from outside. It does not require an air intake in the room where it is installed.

Wall-hung condensing boilers, with stainless steel primary exchanger and ACC (active combustion control) combustion control system, which guarantees functionality, efficiency and low emissions in all circumstances.

RESIDENCE HM KIS can be installed indoors or outdoors in a partially protected place, i.e. in a place where the boiler is not exposed to the direct action and infiltration of rain, snow or hail. The boiler can operate in a temperature range from 0 to 60°C (from -15°C to 60°C with resistor kit)

RESIDENCE HM KIS is compatible with the Hi Comfort K100 key and can manage up to two system zones by adding the appropriate electronic kits.

Class 6 NOx according to UNI EN 15502-1. Equipped with a multifunction control panel with backlit LCD display, with touch screen and accompanying BUZZER, user functions and scrolling descriptive keys.

RESIDENCE HM KIS also allows you to easily change the type of gas supply simply by acting on the control panel; the self-adaptive combustion control automatically adjusts all combustion parameters without acting on the gas valve.

CONSTRUCTION DESCRIPTION FOR SPECIFICATIONS

RESIDENCE HM KIS is a type C condensing boiler designed for heating and the production of domestic hot water and, depending on the type of installation, is identified in two categories:

- B23P-B53P type boiler, forced open installation, with flue gas evacuation duct and combustion air intake from the room in which it is installed. If the boiler is not installed outdoors, the air intake in the installation room is mandatory;
- type C(10)3 boiler; C13,C13x; C33,C33x; C43,C43x; C53,C53x; C63,C63x; C83,C83x; C93,C93x: sealed chamber appliance with flue gas evacuation duct and combustion air intake from outside. It does not require an air intake in the room where it is installed.

They are equipped with

- New ACC (active combustion control) combustion control system. This innovative control system, developed by Riello, guarantees functionality, efficiency and low emissions in all circumstances. The ACC system uses an ionization sensor immersed in the burner flame which, through its information, allows the control board to act on the gas valve that regulates the fuel. This sophisticated control system allows self-regulation of combustion, eliminating the need for initial calibration.
- Maximum heat output adaptable to the heat requirements of the system, for heating operation of the boiler itself. Once the desired power (maximum heating) has been set, report the value and, for subsequent checks, refer to the new value;
- High modulation 1:10
- IOT Ready
- Adaptable to operate with different gas compositions, different tube lengths and different altitudes (within the expected design limits) thanks to the ACC system;
- A self-diagnosis can be carried out which blocks the burner before exceeding emission thresholds higher than the limits allowed by the regulations thanks to the ACC system;
- High efficiency modulating circulator already connected hydraulically and electrically, with 6 meter head curve;
- Anti-locking system that starts an operating cycle every 24 hours of parking with function selector in any position;
- Main exchanger in stainless steel
- Premix burner with low polluting emissions Class 6 NOx, according to UNI EN 15502-1, with non-return valve (clapet), fan, high modulation mixer and gas diaphragm

- Filling cock, deaeration cock
- Siphon
- Exhaust valve
- Pressure transducer
- Safety valve
- Return probe, flue gas probe, and flow probe
- Automatic antifreeze system, which activates when the primary circuit water temperature drops below 5°C. This system is always active and guarantees protection of the boiler up to an air temperature in the installation site of 0°C (protection down to -15°C with antifreeze heaters available as an accessory)
- Limit thermostat
- Flame detection electrode/ionization sensor and ignition electrode
- Ignition transformer
- Prepared with flue analysis socket cap
- 9 liter expansion vessel
- Hydraulic three-way valve (stepper)
- Hydrometer
- Lower air vent valve
- The control panel acts as a machine interface, displays the settings relating to the system and makes it possible to access the parameters. The display normally shows the delivery temperature of the boiler (in the case of a boiler with probe - optional) unless a heat request is in progress in heating, in this case the delivery temperature of the boiler is displayed; after 10 seconds of not touching any button the interface displays the current time (backlight off).
- Programmable anti-legionella function. Supplied with:
 - Bypass valve
 - Flat gasket
 - SRD device
 - Condensate drain pipe
 - Flexible hose
 - Safety valve
 - 4-pole connector
 - 8-pole connector

CONFORMITY

The RESIDENCE HM boiler is compliant with the following:

- Directive 2009/142/EC on gas appliances until 20 April 2018 and Regulation (EU) 2016/426 from 21 April 2018
- Efficiency Directive: Article 7(2) and Annex III of 92/42/EEC
- Electromagnetic Compatibility Directive 2014/30/EU
- Low Voltage Directive 2014/35/EU
- Directive 2009/125/EC Eco-design of energy-related products
- Regulation (EU) 2017/1369 energy labelling
- Delegated Regulation (EU) No. 811/2013
- Delegated Regulation (EU) No. 813/2013
- UNI EN 15502-1

CONDENSING BOILERS

Wall-hung condensing boilers

BRIEF DESCRIPTION FOR SPECIFICATIONS

RESIDENCE HM IS

RESIDENCE HM IS is a wall-hung condensing boiler to be used only for heating and/or domestic hot water production with an external DHW cylinder and, depending on the type of installation, it is identified in two categories:

- B23P-B53P type boiler, forced open installation, with flue gas evacuation duct and combustion air intake from the room in which it is installed. If the boiler is not installed outdoors, the air intake in the installation room is mandatory;
- type C(10)3 boiler; C13,C13x; C33,C33x; C43,C43x; C53,C53x; C63,C63x; C83,C83x; C93,C93x: sealed chamber appliance with flue gas evacuation duct and combustion air intake from outside. It does not require an air intake in the room where it is installed.

Wall-hung condensing boilers, with stainless steel primary exchanger and ACC (active combustion control) combustion control system, which guarantees functionality, efficiency and low emissions in all circumstances. RESIDENCE HM IS can be installed indoors or outdoors in a partially protected place, i.e. in a place where the boiler is not exposed to the direct action and infiltration of rain, snow or hail. The boiler can operate in a temperature range from 0 to 60°C (from -15°C to 60°C with resistor kit).

Class 6 NO_x according to UNI EN 15502-1. Equipped with a multifunction control panel with backlit LCD display, with touch screen and accompanying BUZZER, user functions and scrolling descriptive keys.

RESIDENCE HM IS also allows you to easily change the type of gas supply simply by acting on the control panel; the self-adaptive combustion control automatically adjusts all combustion parameters without acting on the gas valve.

CONSTRUCTION DESCRIPTION FOR SPECIFICATIONS

RESIDENCE HM IS is a wall-hung condensing boiler to be used only for heating and/or domestic hot water production with an external DHW cylinder and, depending on the type of installation, it is identified in two categories:

- B23P-B53P type boiler, forced open installation, with flue gas evacuation duct and combustion air intake from the room in which it is installed. If the boiler is not installed outdoors, the air intake in the installation room is mandatory;
- type C(10)3 boiler; C13,C13x; C33,C33x; C43,C43x; C53,C53x; C63,C63x; C83,C83x; C93,C93x: sealed chamber appliance with flue gas evacuation duct and combustion air intake from outside. It does not require an air intake in the room where it is installed.

RESIDENCE HM IS is compatible with the Hi Comfort K100 key and can manage up to two system zones by adding the appropriate electronic kits

They are equipped with:

- New ACC (active combustion control) combustion control system. This innovative control system, developed by Riello, guarantees functionality, efficiency and low emissions in all circumstances. The ACC system uses an ionization sensor immersed in the burner flame which, through its information, allows the control board to act on the gas valve that regulates the fuel. This sophisticated control system allows self-regulation of combustion, eliminating the need for initial calibration.
- Maximum heat output adaptable to the heat requirements of the system, for heating operation of the boiler itself. Once the desired power (maximum heating) has been set, report the value and, for subsequent checks, refer to the new value;
- High modulation 1:10
- IOT Ready
- Adaptable to operate with different gas compositions, different tube lengths and different altitudes (within the expected design limits) thanks to the ACC system;
- A self-diagnosis can be carried out which blocks the burner before exceeding emission thresholds higher than the limits allowed by the regulations thanks to the ACC system;
- High efficiency modulating circulator already connected hydraulically and electrically, with 6 meter head curve;
- Anti-locking system that starts an operating cycle every 24 hours of parking with function selector in any position;
- Main exchanger in stainless steel
- Premix burner with low polluting emissions Class 6 NO_x, according to UNI EN 15502-1, with non-return valve (clapet), fan, high modulation mixer and gas diaphragm

- Filling cock, deaeration cock
- Siphon
- Exhaust valve
- Pressure transducer
- Safety valve
- Return probe, flue gas probe, and flow probe
- Automatic antifreeze system, which activates when the primary circuit water temperature drops below 5°C. This system is always active and guarantees protection of the boiler up to an air temperature in the installation site of 0°C (protection down to -15°C with antifreeze heaters available as an accessory)
- Limit thermostat
- Flame detection electrode/ionization sensor and ignition electrode
- Ignition transformer
- Prepared with flue analysis socket cap
- 9 liter expansion vessel
- Hydraulic three-way valve (stepper)
- Hydrometer
- Lower air vent valve
- The control panel acts as a machine interface, displays the settings relating to the system and makes it possible to access the parameters. The display normally shows the delivery temperature of the boiler (in the case of a boiler with probe - optional) unless a heat request is in progress in heating, in this case the delivery temperature of the boiler is displayed; after 10 seconds of not touching any button the interface displays the current time (backlight off).
- Programmable anti-legionella function. Supplied with:
 - Bypass valve
 - Flat gasket
 - SRD device
 - Condensate drain pipe
 - Flexible hose
 - Safety valve
 - 4-pole connector
 - 8-pole connector

CONFORMITY

The RESIDENCE HM boiler is compliant with the following:

- Directive 2009/142/EC on gas appliances until 20 April 2018 and Regulation (EU) 2016/426 from 21 April 2018
- Efficiency Directive: Article 7(2) and Annex III of 92/42/EEC
- Electromagnetic Compatibility Directive 2014/30/EU
- Low Voltage Directive 2014/35/EU
- Directive 2009/125/EC Eco-design of energy-related products
- Regulation (EU) 2017/1369 energy labelling
- Delegated Regulation (EU) No. 811/2013
- Delegated Regulation (EU) No. 813/2013
- UNI EN 15502-1

RIELLO

RIELLO S.p.A. -
37045 Legnago (VR) Italy
tel. +39 0442 630111



RESIDENCE HM

www.riello.com



The company is constantly working to perfect the features of its entire production range so the design and size, technical data, equipment and accessories may be subject to change.



©2024 Carrier. All rights reserved.
All product and service marks mentioned in this document are the property of their respective owners.