

## Wall-hung condensing boilers



# RESIDENCE AQUA

Wall-hung condensing boilers with DHW bi-tank

Combined boiler with 30-liter stainless steel DHW bi-tank  
Compact and robust stainless steel primary heat exchanger  
Simple and intuitive digital user interface  
Designed to operate with mixtures of natural gas and hydrogen, up to a maximum of 20%

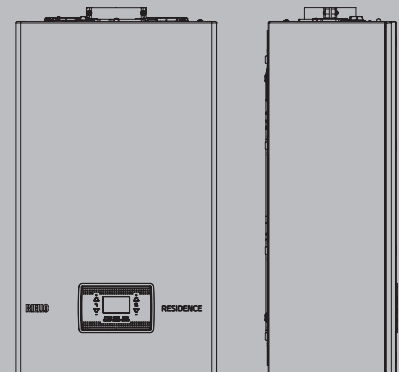

# RESIDENCE AQUA with DHW Bi-Tank (dosseret)

## PRODUCT DESCRIPTION

RESIDENCE AQUA is the condensing boiler with 30-liter stainless steel DHW bi-tank designed by Riello with energy saving and efficiency in mind.

RESIDENCE AQUA consists of a system composed of a 25 kW combi boiler and a DHW bi-tank that is distinguished by the simplicity of installation in just two steps: installation of the DHW bi-tank on the wall and the boiler on it.

The primary heat exchanger, made entirely of stainless steel and with front accessibility to the combustion chamber, together with the optimized plate heat exchanger for instantaneous DHW production during periods when the DHW tank is not needed, ensure maximum efficiency, long-term reliability and high comfort.

Compact dimensions and an intuitive user interface complete the profile of RESIDENCE AQUA.

- 25 kW combi boiler with 30-liter stainless steel DHW tank, available with dedicated code.
- Ability to enable and disable boiler operation in conjunction with the DHW tank thanks to advanced machine electronics.
- Two-step installation simplicity: 1. installation of the DHW tank; 2. installation of the boiler on the DHW tank.
- Efficient, reliable stainless steel primary condensing heat exchanger with front access for easy maintenance and cleaning of the combustion chamber.
- Simple and intuitive digital user interface with backlit LCD display for direct communication through multilingual text and representative icons.
- Modulation ratio 1:8.
- IPX5D electrical protection degree.
- Hydraulic group with DIN standard sequence.
- Can be matched with the Hi, Comfort T100.
- Designed to operate with mixtures of natural gas and hydrogen, up to a maximum of 20%.
- Natural gas operation as standard with possibility of conversion to LPG (G31) and propane air through accessories. This modification must be carried out by the installer or by the technical assistance service.

## TECHNICAL DATA

Description	UM	RESIDENCE AQUA 25 BIS		
		G20	G230	G31
Gas type				
Appliance category			I12HY20M3P	
Country of destination			IT	
Appliance type		B23P; B53P; C(10)3; C13,C13x; C33,C33x; C43,C43x; C53,C53x; C63,C63x; C83,C83x; C93,C93x		
<b>HEATING</b>				
Nominal heat input (Hi) (l)	kW		20,00	
Nominal heat output (80÷60°C)	kW		19,40	
Nominal heat output (50÷30°C)	kW		20,92	
Reduced heat input (Hi)	kW	3,10		5,00
Reduced heat output (80÷60°C)	kW	2,94		4,74
Reduced heat output (50÷30°C)	kW	3,04		4,91
<b>DOMESTIC WATER</b>				
Nominal heat input (Hi) (l)	kW		25,00	
Nominal heat output (*)	kW		25,00	
Reduced heat input (Hi)	kW	3,10		5,00
Reduced heat output (*)	kW	3,10		5,00
<b>EFFICIENCY</b>				
Useful efficiency P max (80÷60°C)	%		96,9	
Useful efficiency P min (80÷60°C)	%		94,7	
Useful efficiency Pn max (50÷30°C)	%		104,6	
Useful efficiency Pn min (50÷30°C)	%		98,0	
Useful efficiency 30% (return 30°C)	%		109,1	
Efficiency at Pmedia Range Rated (80÷60°C)(***)	%		97,0	
Efficiency at Pmedia Range Rated 30% (30°C return)(***)	%		109,3	
Chimney losses with burner on (Pn max)	%		2,80	
Chimney losses with burner off	%		0,09	

Description	UM	RESIDENCE AQUA 25 BIS		
		G20	G230	G31
Gas type				
Casing losses with burner on (Pn max)	%		0,30	
<b>FLUE GAS SYSTEM</b>				
NOx Class – UNI EN 15502			6	
Residual head of concentric flues 0,85 m Ø60–100 mm	Pa		60	
Residual head of twin flues 0,5 m Ø80–80 mm	Pa		180	
Residual head of boiler without pipes and without flange	Pa		186	
<b>ELECTRICAL CHARACTERISTICS</b>				
Electrical power (Pel max heating–Pel max DHW)	W		62–95	
Electrical power of burner P max	W		53	
Electrical power of circulator max	W		42	
Electrical power of circulator min	W		4	
Power supply voltage	V – Hz		230–50	
Protection level	IP		X5D	
<b>HEATING OPERATION</b>				
Maximum pressure	bar		3	
Minimum pressure for standard operation	bar		0,3	
Maximum temperature	°C		90	
Heating H <sub>2</sub> O temperature selection range	°C		20/45 – 40/80	
Pump: max. head available to the system	mbar		340	
at the flow rate of	l/h		1000	
Membrane expansion vessel	l		8	
Expansion vessel pre-load	bar		1	
<b>DOMESTIC HOT WATER OPERATION – INSTANTANEOUS VERSION</b>				
Maximum pressure	bar		8	
Minimum pressure	bar		0,5	
Quantity of hot water with Δt 25°C	l/min		14,3	
with Δt 30°C	l/min		11,9	
with Δt 35°C	l/min		10,2	
Minimum domestic hot water flow rate	l/min		2	
Domestic H <sub>2</sub> O temperature selection range	°C		37/60	
Flow regulator	l/min		10	
<b>AIR AND FLUE GAS FLOW RATES</b>				
Gas type		<b>G20</b>	<b>G230</b>	<b>G31</b>
<b>Heating</b>				
Air flow rate	Nm <sup>3</sup> /h	24,3	24,1	24,8
Flue gas flow rate	Nm <sup>3</sup> /h	26,3	26,4	26,4
Mass flow rate of flue gas (max–min)	g/s	9,1–1,4	9,3–1,4	9,3–2,3
<b>Domestic</b>				
Air flow rate	Nm <sup>3</sup> /h	30,4	30,1	31,0
Flue gas flow rate	Nm <sup>3</sup> /h	32,9	33,1	32,9
Mass flow rate of flue gas (max–min)	g/s	11,4–1,4	11,7–1,4	11,6–2,3
<b>EMISSION VALUES AT MAX AND MIN FLOW RATE WITH GAS (**)</b>				
Gas type		<b>G20</b>	<b>G230</b>	<b>G31</b>
<b>Maximum</b>				
CO s.a. lower than	p.p.m	140	80	140
CO <sub>2</sub> (***)	%	9,1	10,1	10,1
NOx s.a. lower than	p.p.m	50	50	40
Flues temperature	°C	77	78	81
<b>Minimum</b>				
CO s.a. lower than	p.p.m	10	10	30
CO <sub>2</sub> (***)	%	9,1	10,1	10,1
NOx s.a. lower than	p.p.m	30	50	40
Flues temperature	°C	64	61	63

(\*) Average value between the various operating conditions in domestic hot water.

(\*\*) Test performed with concentric flues Ø60–100 mm – length 0,85 m – water temperature 80±60°C.

(\*\*\*) Values certified by a third party for the Range Rated models.

(i) RESIDENCE AQUA 25 BIS, the heat output with G20Y20 gas (12HY20) is weakened:

Nominal heat output in heating = 18 kW

Nominal heat output in domestic hot water = 23kW.

The data expressed must not be used to certify the system; for certification, the data indicated in the "System Booklet" measured at the time of first ignition must be used.

## WALL-HUNG CONDENSING BOILERS

Wall-hung condensing boilers with DHW bi-tank

### VALUES RELATING TO DHW PERFORMANCE WITH BOILER IN CASE OF DOSSERET KIT INSTALLATION (AVAILABLE ON REQUEST)

DHW tank type	∅	Stainless Steel
DHW tank layout	∅	Vertical
Exchanger layout	∅	external with plates
<b>Vnom, actual domestic hot water content</b>	<b>l</b>	<b>31</b>
Domestic hot water temperature selection range	°C	37-60
Quantity of water drawn in 10' with minimum T 30°C	l	145
Maximum boiler operating pressure	bar	10
Vbu, non-solar storage volume	L	31
Specific flow rate according to en 13203-1	l/min	14,5

### ERP TECHNICAL DATA

Description	Symbol	UM	RESIDENCE AQUA 25 BIS
Seasonal space heating efficiency class		D → A+++ (1)	A
Water heating energy efficiency class		F → A+ (1)	A
Nominal output	Nominal P	kW	19
Seasonal space heating energy efficiency	ηs	%	93
<b>USEFUL HEAT OUTPUT</b>			
At nominal heat output and high temperature regime (*)	P4	kW	19,4
At 30% of the nominal heat output and at a low temperature regime (**)	P1	kW	6,5
<b>EFFICIENCY</b>			
At nominal heat output and high temperature regime (*)	η4	%	87,3
At 30% of the nominal heat output and at a low temperature regime (**)	η1	%	98,5
<b>AUXILIARY ELECTRICITY CONSUMPTION</b>			
At full load	elmax	W	32,0
At partial load	elmin	W	12,0
In standby mode	PSB	W	3,0
<b>OTHER PARAMETERS</b>			
Heat losses in standby mode	Pstby	W	30,0
Energy consumption of the pilot flame	Pign	W	-
Annual energy consumption	QHE	GJ	42
Indoor sound power level	LWA	dB	50
Nitrogen oxide emissions	NOx	mg/kWh	22
<b>FOR COMBINATION HEATERS</b>			
Declared load profile			XL
Water heating energy efficiency	ηwh	%	84
Daily electricity consumption	Qelec	kWh	0,133
Daily fuel consumption	Qfuel	kWh	23,183
Annual electricity consumption	AEC	kWh	29
Annual fuel consumption	AFC	GJ	18

(1) The energy efficiency class range of this product category in HEATING is between D and A+++ / in DHW is between F and A+\*

(\*) High temperature regime: 60°C return and 80°C boiler flow.

(\*\*) Low temperature regime: for condensing boilers 30°C, for low temperature boilers 37°C, for other heating appliances 50°C return temperature.

### For combined heating appliances: BOILER WITH DOSSERET

Load profile			XL
Daily electricity consumption	Qelec	kWh	0,286
Annual electricity consumption	AEC	kWh	63
<b>Water heating energy efficiency</b>	<b>ηwh</b>	<b>%</b>	<b>80</b>
Daily fuel consumption	QFUEL	KWH	24,268
Annual fuel consumption	AFC	GJ	18

## NOTE

With reference to the delegated regulation (EU) No 811/2013, the data represented in the table can be used for the completion of the product sheet and the labelling for space heaters, combination heaters, packages of space heaters, temperature control devices and solar devices:

Component	Class	Bonus
DHW tank probe	II	2%
OT+ remote control	V	3%
Outdoor probe + OT+ remote control	VI	4%

## TABLE LAW 10

Description	UM	RESIDENCE AQUA 25 BIS		
		G20	G230	G31
<b>MAXIMUM THERMAL POWER</b>				
Gas type				
Useful (80÷60°C)	kW		19,40	
Useful (50÷30°C)	kW		20,92	
Fireplace	kW		20,00	
<b>MINIMUM HEAT POWER</b>				
Useful (80÷60°C)	kW		2,94	
Useful (50÷30°C)	kW		3,04	
Fireplace	kW		3,10	
<b>YIELD</b>				
Useful efficiency Pn max-Pn min (80÷60°C)	%		96,9	
Useful efficiency Pn max-Pn min (50÷30°C)	%		104,6	
Useful efficiency 30% (return 30°C)	%		109,1	
Losses in the chimney with burner on (Pn max)	%		2,8	
Losses in the chimney with burner off	%		0,09	
Losses in the casing with burner on (Pn max)	%		0,3	
<b>EMISSION VALUES AT MAX AND MIN FLOW WITH GAS (*)</b>				
<b>Maximum</b>				
CO s.a. lower than	p.p.m	140	80	140
CO <sub>2</sub>	%	9	10	10
Nox s.a. lower than	p.p.m	50	50	40
Flues temperature	°C	77	78	81
<b>Minimum</b>				
CO s.a. lower than	p.p.m	10	10	30
CO <sub>2</sub>	%	9	10	10
NOx s.a. lower than	p.p.m	30	50	40
Flues temperature	°C	64	61	63
NOx class			6	
Electric power: burner, circulator, total	W		62-95	

\* Test performed with concentric flue gas Ø60-100 mm - length 0,85 m - water temperature 80÷60°C.

## WALL-HUNG CONDENSING BOILERS

Wall-hung condensing boilers with DHW bi-tank

### CONDENSING BOILER RESIDENCE AQUA 25 BIS

#### OVERALL DIMENSIONS

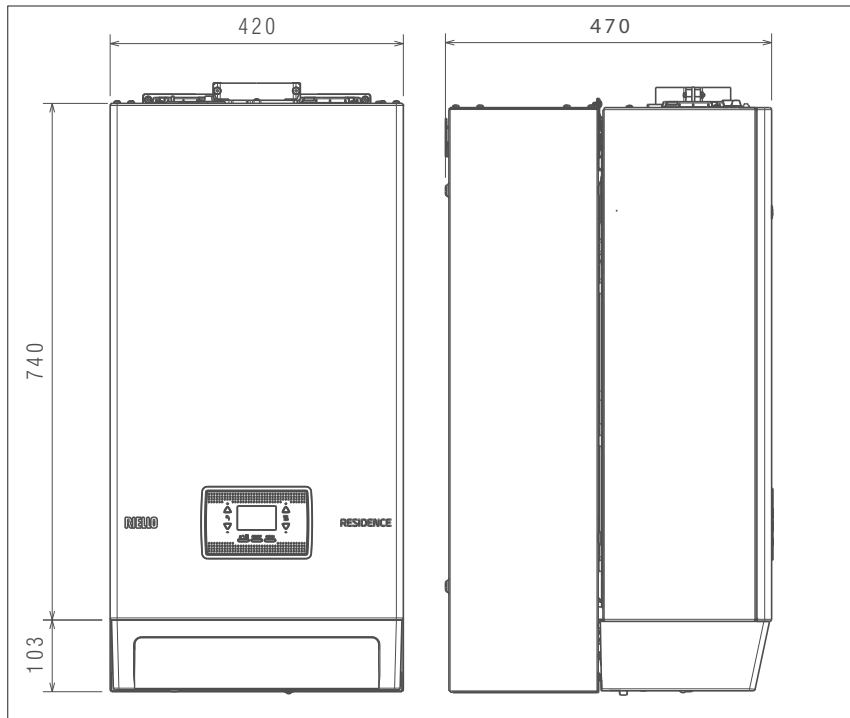

Description	UM	RESIDENCE AQUA 25 BIS
Height (H)	mm	740
Width (L)	mm	420
Depth (D)	mm	250
Net weight	kg	31,0

#### INSTALLATION PLACE

The RESIDENCE AQUA boiler can be installed indoors in multiple rooms as long as the exhaust of the combustion products and the intake of the combustion air are brought outside the room itself. In this case the room does not require any ventilation openings because it is a boiler with a combustion circuit that is "sealed" with respect to the installation environment. If, however, the combustion air is taken from the installation room, this must be equipped with ventilation openings that comply with the Technical Standards and are adequately sized. RESIDENCE AQUA can be installed outdoors in a partially protected place, i.e. in a place where the boiler is not exposed to the direct action and infiltration of rain, snow or hail.

The boiler can operate in a temperature range from  $>0^{\circ}\text{C}$  to  $+60^{\circ}\text{C}$ .

Take into account the spaces needed for accessibility to the safety and regulation devices and for carrying out maintenance operations.

**IMPORTANT:** Before installation, we recommend thoroughly washing all the flue gas system to remove any residues that could compromise the proper functioning of the boiler.

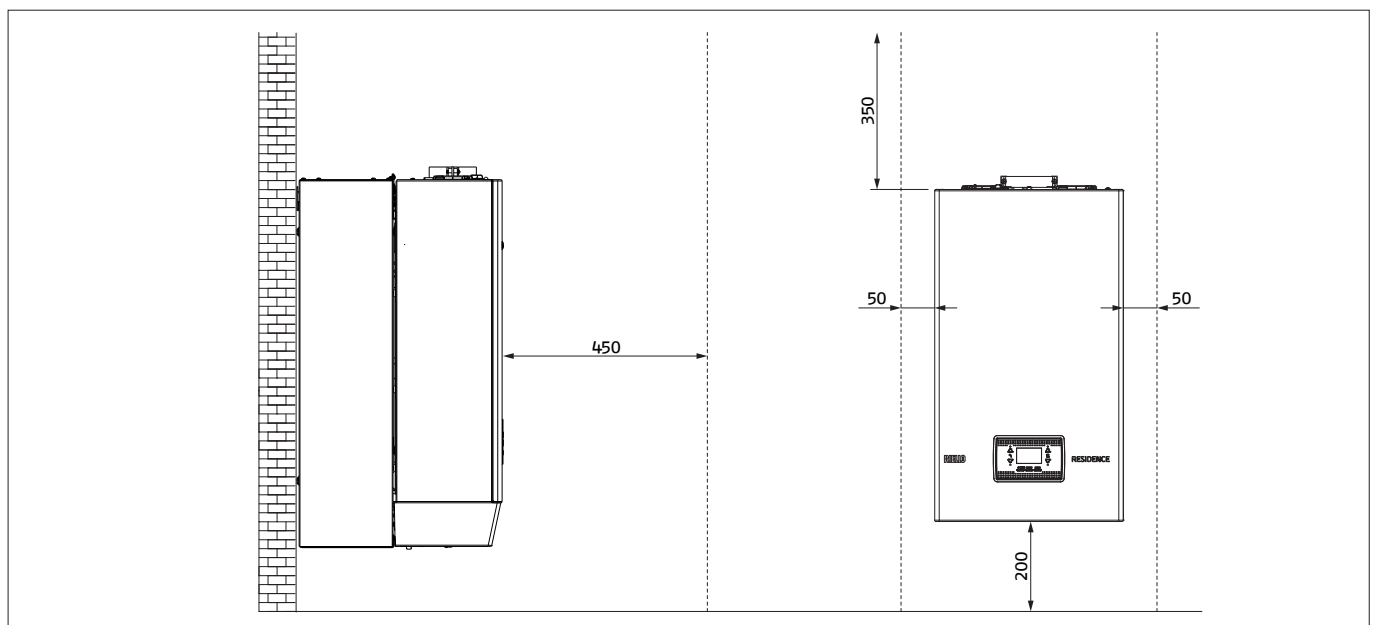

## STRUCTURE

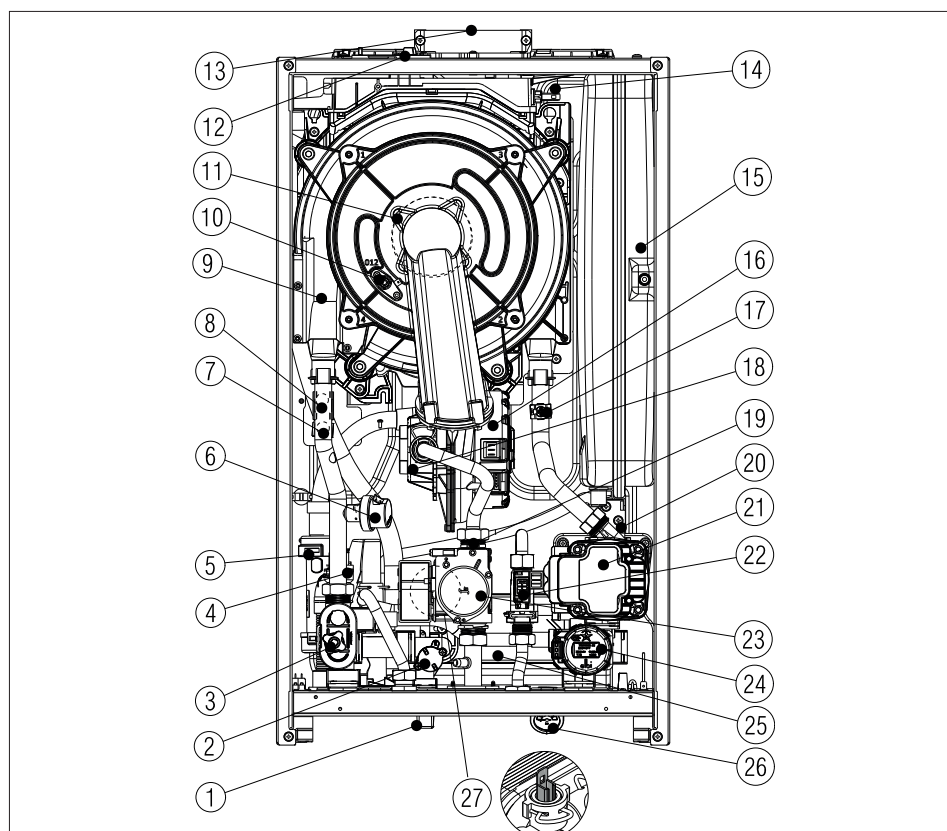

1. Filling tap
2. Non-return valve
3. Drain valve
4. Safety valve
5. Condensate siphon
6. Pressure transducer
7. NTC flow probe
8. Limit thermostat
9. Exchanger
10. Ignition electrode/flame detection/ ionization sensor
11. Burner
12. Flue analysis socket cap
13. Flue exhaust
14. Flue probe
15. Expansion vessel
16. Fan
17. NTC return probe
18. Mixer
19. Gas diaphragm
20. Air vent valve
21. Circulation pump
22. Flow switch
23. Gas valve
24. Electric three-way valve
25. DHW exchanger
26. Hydrometer
27. DHW NTC probe

## DOSSERET KIT (AVAILABLE ON REQUEST)

The Dossieret kit combined with the boiler allows you to have a reserve of water always available at the desired temperature. The system, consisting of a boiler with a 30 lt DHW tank, is easy to assemble: the first step is to install the DHW tank on the wall with the choice of the fittings for domestic water that allow the connection with the boiler.

**Installation:**

- fix the template of the dossieret to the wall (1)
- fix the boiler fixing template to the dossieret (2)
- assemble the hydraulic pipe kits and the flow switch kit (3) (available on request)
- hook the boiler to the template (4)
- make the hydraulic connections between the dossieret and the boiler.
- make the electrical connection between the dossieret and the boiler.

Refer to the specific instructions included in the kit for further details.

The boiler with DHW bi-tank technology has the same performance as boilers with 45 and 60 litre coils but with considerably reduced spaces. It is possible, via the parameter in the electronics, to exclude the DHW tank functionality by making the boiler works in instantaneous mode, guaranteeing savings on gas consumption.

**P5.20 = 1** DHW bi-tank enabled, domestic hot water tank

**P5.20 = 0** DHW bi-tank function excluded, the boiler works in mode guaranteeing savings on gas consumption

Parameter P5.21 manages the DHW bi-tank reset frequency:

**COMFORT** causes the boiler to have more and more frequent boiler filling cycles. This setting is recommended in domestic applications where the withdrawal cycles are frequent or where the water volume request is higher.

**ECO** leads the boiler to have a reduced number of DHW bi-tank filling cycles. This choice should be made when you want greater energy savings.

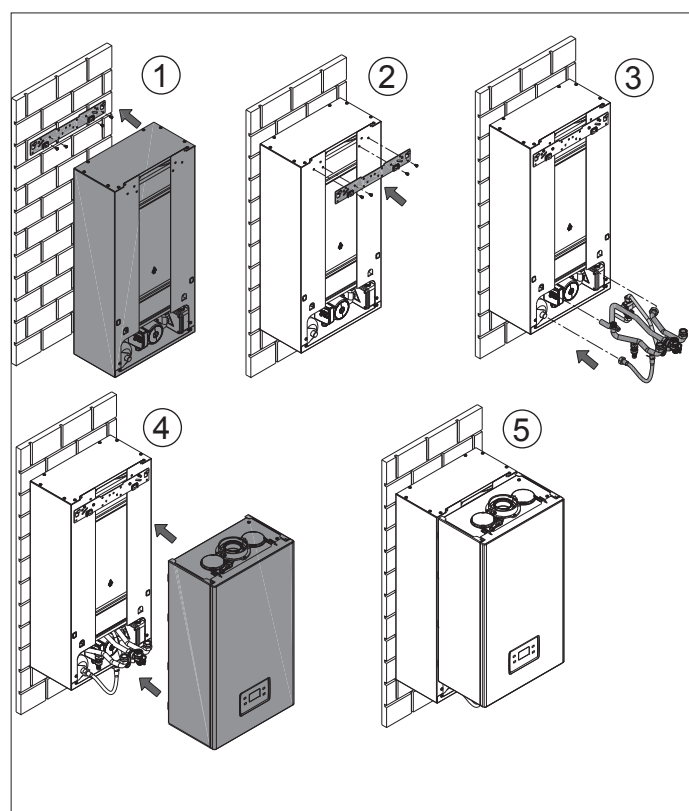

## WALL-HUNG CONDENSING BOILERS

Wall-hung condensing boilers with DHW bi-tank

### HYDRAULIC CONNECTIONS

RESIDENCE AQUA 25 BIS

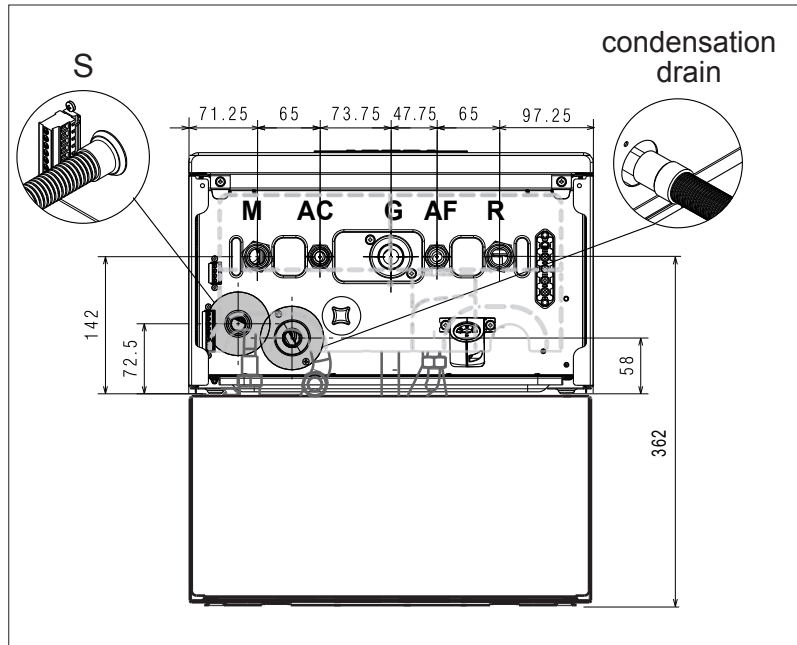

REF.	DESCRIPTION	
R	Heating return	Ø 3/4" M
M	Heating flow	Ø 3/4" M
G	Gas supply	Ø 3/4" M
AC	Hot water (DHW outlet)	Ø 1/2" M
AF	Cold water (DCW inlet)	Ø 1/2" M
S	Safety valve connection	Ø 1/2" M

### HYDRAULIC CIRCUIT

REF.	DESCRIPTION
R	Heating return
M	Heating flow
AC	Hot water (DHW outlet)
AF	Cold water (DCW inlet)
1	Heating return
2	Safety valve
3	Drain valve Automatic by-pass
4	Filling tap
5	Non-return valve
6	DHW probe
7	Pressure transducer
8	Flow probe
9	Limit thermostat
10	Primary exchanger
11	Return probe
12	Expansion vessel
13	Lower air vent valve
14	Circulator
15	Hydrometer
16	Electric three-way valve
17	Flow limiter
18	Flow switch
19	DHW filter

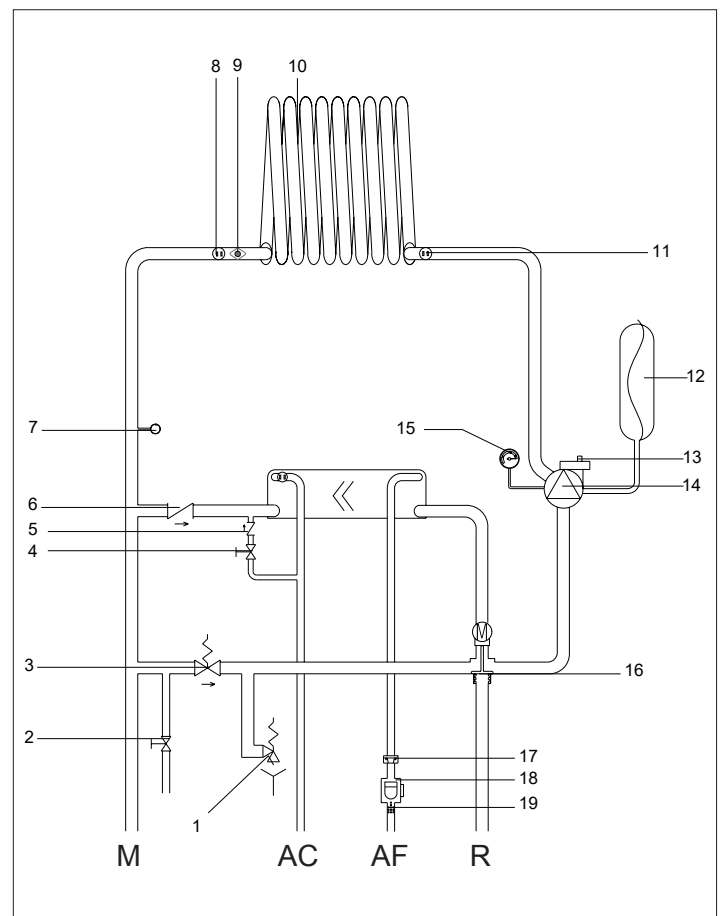

## FLOW RATE-HEAD DIAGRAMS

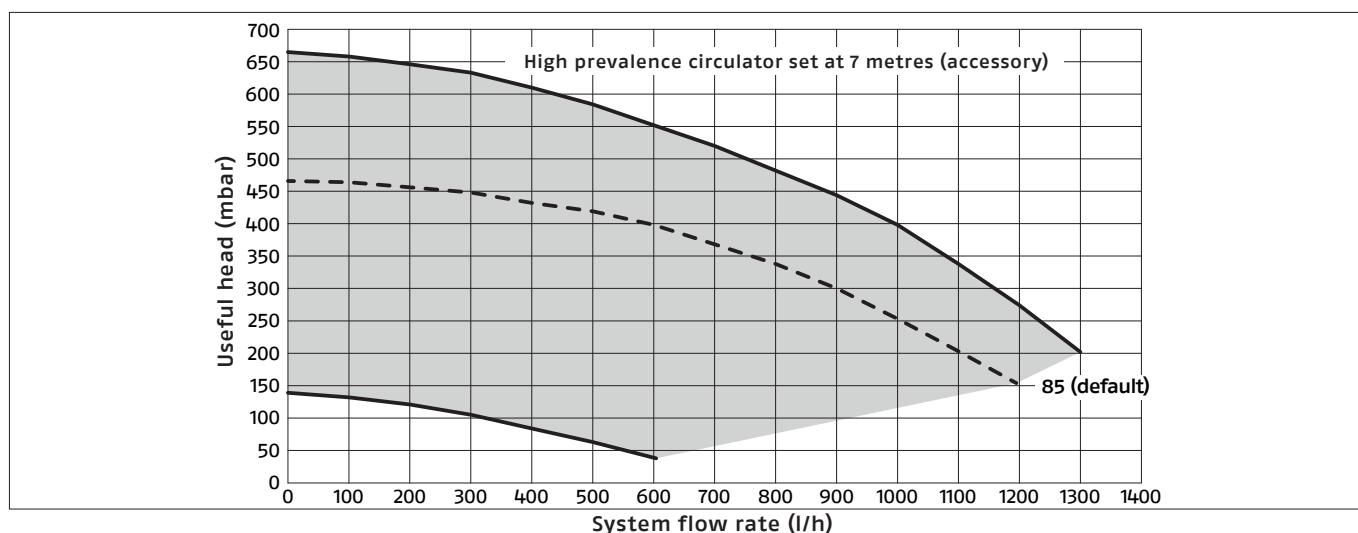
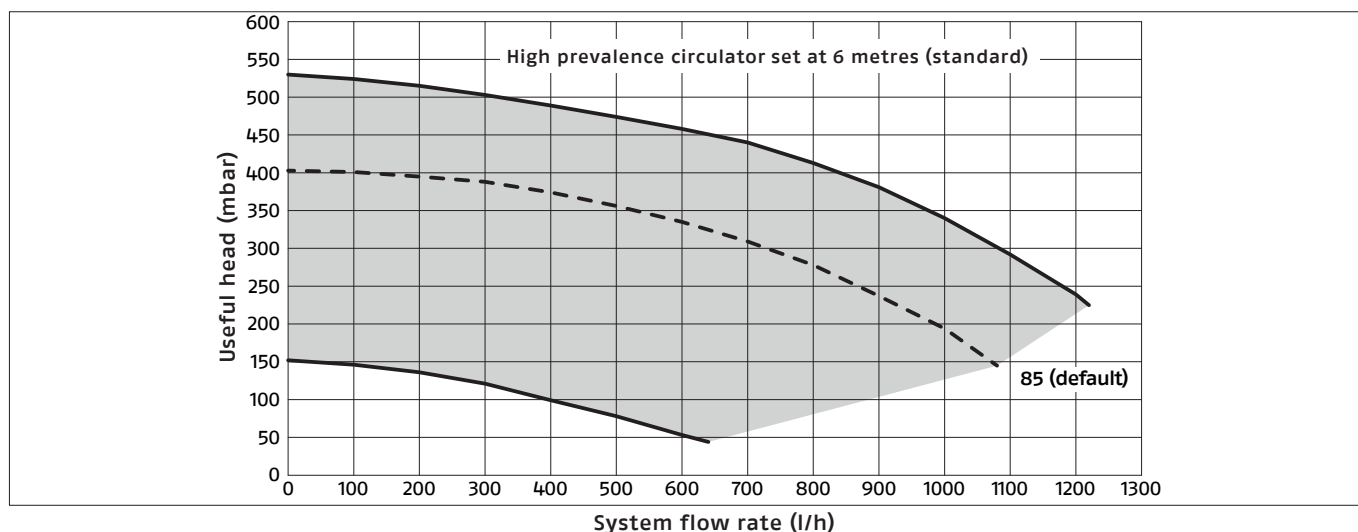

## WATER IN HEATING SYSTEMS

### PHYSICAL AND CHEMICAL CHARACTERISTICS

The chemical-physical characteristics of the water must comply with the European standard EN 14868 and the tables below:

ALUMINUM GENERATORS with Fire Power < 150 kW			
		First fill water	Water on schedule (*)
ph		-	7-8
Hardness	°F	< 15°	-
Appearance		clear	-
Iron	mg/kg	-	< 0,5
Copper	mg/kg	-	< 0,1

(\*) System water values after 8 weeks of operation.

### THE NEW HEATING SYSTEMS

The first loading of the system must be done slowly; once filled and deaerated, the system should not be refilled. During the first start-up, the system must be brought to the maximum operating temperature to facilitate deaeration (too low a temperature prevents the escape of gases).

### REFURBISHMENT OF OLD HEATING SYSTEMS

In case of boiler replacement, if the water quality in the existing systems complies with the requirements, refilling is not recommended. If the water quality does not comply with the requirements, reconditioning of the water or separation of the systems is recommended (in the boiler circuit the water quality requirements must be met).

## WALL-HUNG CONDENSING BOILERS

Wall-hung condensing boilers with DHW bi-tank

### EXHAUST FLUES AND COMBUSTION AIR INTAKE

For the evacuation of combustion products, refer to the UNI 7129 regulation. You must also always comply with the local regulations of the Fire Brigade, the Gas manager and any municipal provisions. The boiler is supplied without the smoke exhaust/air intake kit, as it is possible to use the accessories for condensing appliances that best suit the installation characteristics.

It is essential for the extraction of flues and the supply of combustion air of the boiler that only original pipes are used (except type C6 provided they are certified) and that the connection is made correctly as indicated in the instructions supplied with the flue gas accessories.

Multiple appliances can be connected to a single flue provided that they are all of the condensing type.

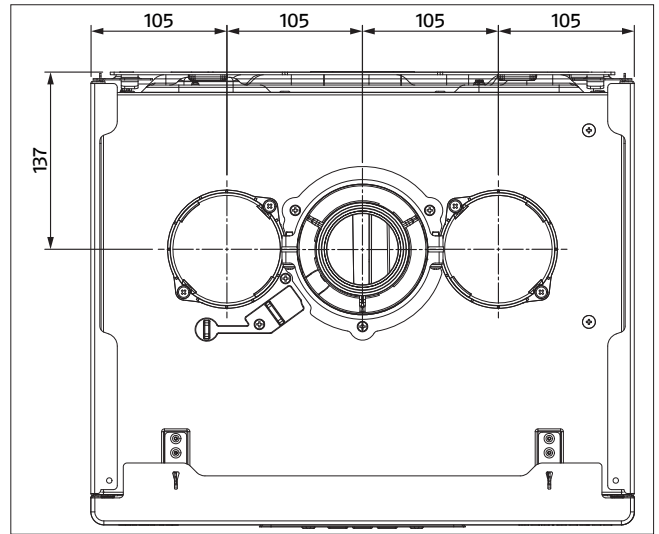

Types of discharge	Maximum straight length (m)	Pressure losses for insertion of each curve (m)	
		25 BIS	45°
Ø80 mm flue gas (B23P-B53P installation type)	48	1	1,5
Ø60-100 mm concentric flue gas (horizontal)	5,85	1,3	1,6
Ø60-100 mm concentric flue gas (vertical)	6,85	1,3	1,6
Ø80-125 mm twin flue gas	14	1	1,5
Ø80 mm twin flue gas (fixed or with adapter)	52+52	1	1,5
Ø80 mm twin flue gas (with compact adapter)	33+33	1	1,5

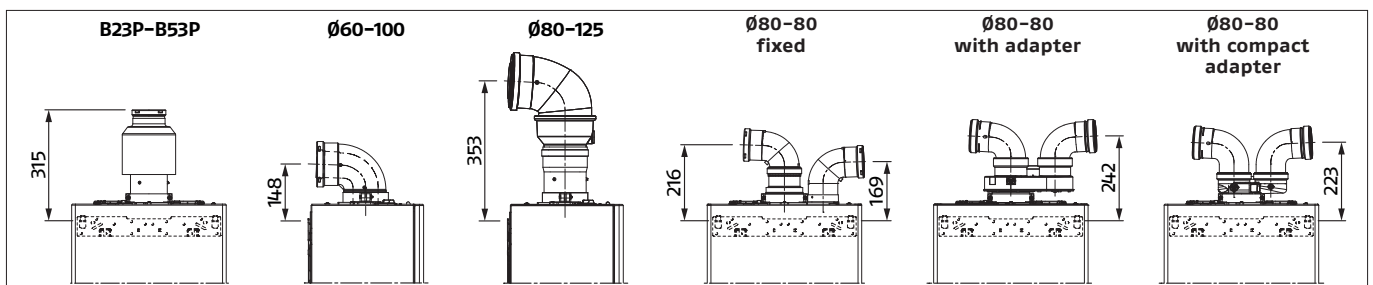

For the indication of the maximum lengths with Ø80-80 mm TWIN FLUE GAS of the single flue gas, refer to the following graphs.

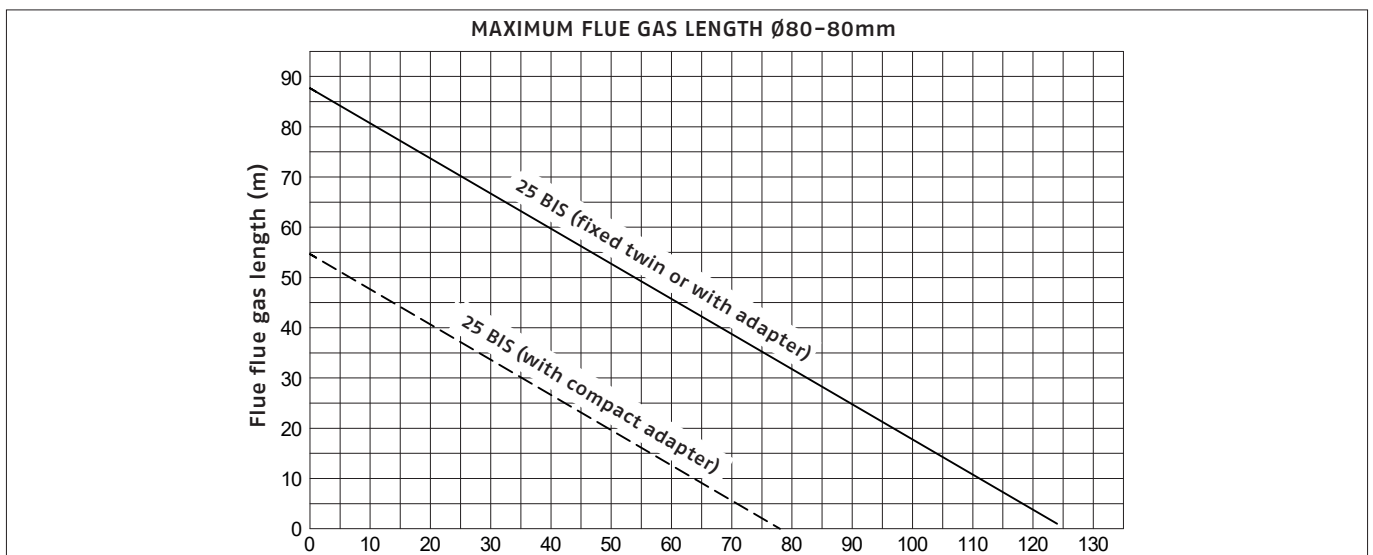

**TWIN SYSTEMS Ø80 WITH Ø50 – Ø60 – Ø80 FLUE GAS**

The boiler features allow the connection of the Ø80 flue gas system to the Ø50 – Ø60 – Ø80 flue gas ranges.

**⚠** For the piping it is recommended to carry out a project calculation in order to comply with the current regulations on the matter.

The table shows the basic configurations of the flue gasses allowed.

Air intake	190° bend Ø80
	4,5 m pipe Ø80
Flues system	190° bend Ø80
	4,5 m pipe Ø80
	Reduction from Ø80 to Ø50 from Ø80 to Ø60
	Chimney base bend 90°, Ø50 or Ø60 or Ø80
For flue gas lengths see table	

The boilers leave the factory calibrated to:

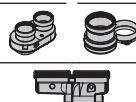
	rpm HEATING	rpm DHW	Max flues length (m)		
			Ø50	Ø60	Ø80
25 kW 	7.000	8.700	6	19	95
			1	9	45

Depending on the lengths, compensate for the pressure drops by increasing the number of fan revolutions as shown in the adjustment table to ensure the rated thermal capacity.

**Flue gas adjustment tables**

 twin flue gas

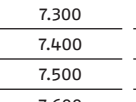
	Fan speed rpm		Flues Ø50	Flues Ø60	Flues Ø80	ΔP boiler outlet
	Heating	DHW	Maximum length (m)			
25 kW 	7.000	8.700	6	19	95	180
	7.100	8.800	12 *	33 *	165 *	260
	7.200	8.900	16 *	39 *	195 *	300
	7.300	9.000	19 *	46 *	230 *	342
	7.400	9.100	23 *	53 *	265 *	383
	7.500	9.200	27 *	61 *	305 *	431
	7.600	9.300	29 *	67 *	335 *	465
	7.700	9.400	32 *	73 *	365 *	500

(\*) Maximum length that can be installed ONLY with class H1 flue gas.

 compact twin flue gas

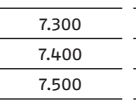
	Fan speed rpm		Flues Ø50	Flues Ø60	Flues Ø80	ΔP boiler outlet
	Heating	DHW	Maximum length (m)			
25 kW 	7.000	8.700	1	9	45	180
	7.100	8.800	7 *	23 *	115 *	260
	7.200	8.900	11 *	29 *	145 *	300
	7.300	9.000	14 *	36 *	180 *	342
	7.400	9.100	18 *	43 *	215 *	383
	7.500	9.200	22 *	51 *	255 *	431
	7.600	9.300	24 *	57 *	285 *	465
	7.700	9.400	27 *	63 *	315 *	500

(\*) Maximum length that can be installed ONLY with class H1 flue gas.

The Ø50 or Ø60 or Ø80 configurations show experimental data verified in the Laboratory. In case of installations different from those indicated in the "basic configurations" and "adjustments" tables, refer to the equivalent linear lengths reported below.

Component	Linear equivalent in meters Ø80 (m)	
	Ø50	Ø60
45° Bend	12,3	5
90° Bend	19,6	8
0,5 m Extension	6,1	2,5
1,0 m Extension	13,5	5,5
2,0 m Extension	29,5	12

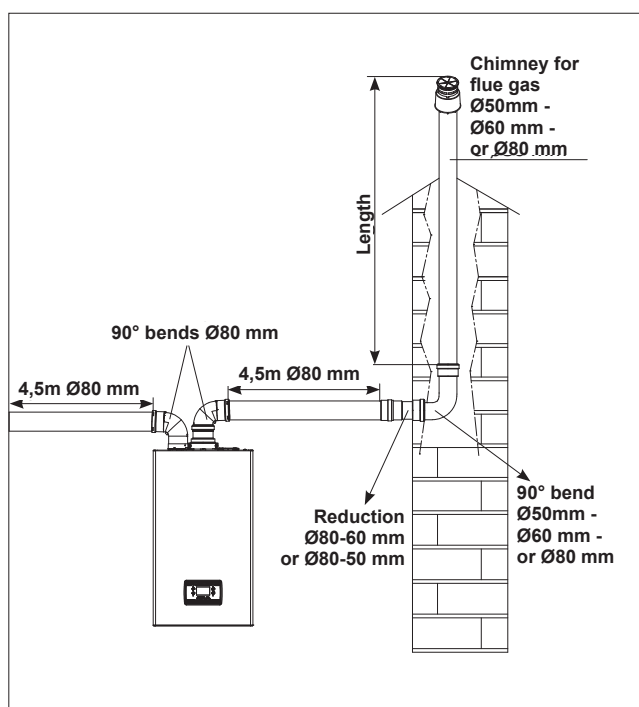

## WALL-HUNG CONDENSING BOILERS

Wall-hung condensing boilers with DHW bi-tank

### ELECTRICAL CONNECTIONS

RESIDENCE AQUA 25 BIS

The RESIDENCE AQUA 25 BIS boiler leaves the factory fully wired. The following connections are sufficient:

- to the electrical network with single-phase voltage at 230V-50Hz, using the provided cable;
- to the Bus 485 (- A B +);
- to the low temperature thermostat (TBT);
- to the room thermostat (TA/OT+) – clean contact (Opentherm);
- to the outdoor probe (SE).

The connection to the electrical network must be made via a separation device with an omnipolar opening of at least 3,5 mm (EN 60335-1, category III). The appliance operates with alternating current at 230 Volts/50 Hz and complies with the EN 60335-1 standard.

In the event of replacing the power cable, use a cable of the type HAR H05V2V2-F, 3 x 0,75 mm<sup>2</sup>, max. external diameter 7 mm.

It is mandatory:

- the use of an omnipolar magnetothermal switch, line disconnect, compliant with CEI-EN Standards (contact opening of at least 3 mm);
- respect the L (Phase), N (Neutral) connection;
- use cables with a section greater than or equal to 1,5 mm<sup>2</sup>, complete with cable lugs;
- create an effective earth connection.

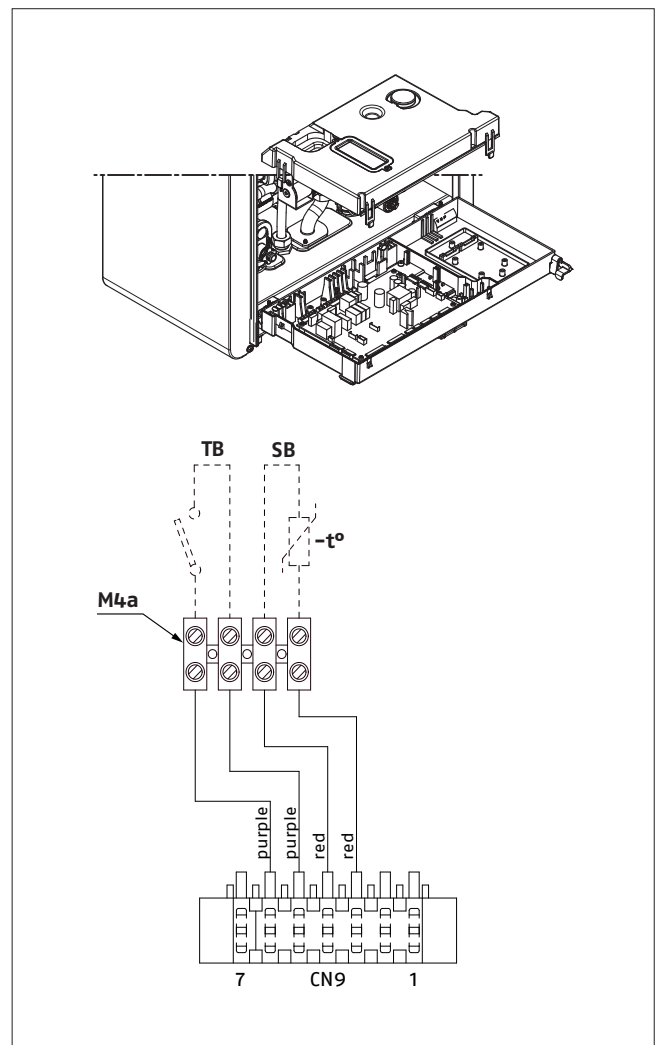
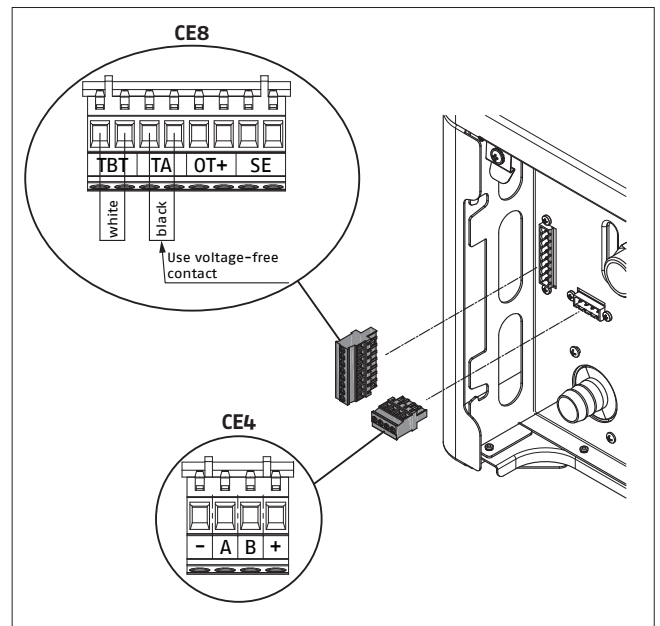

## DHW BI-TANK (DOSSERET - ACCESSORY)

### STRUCTURE

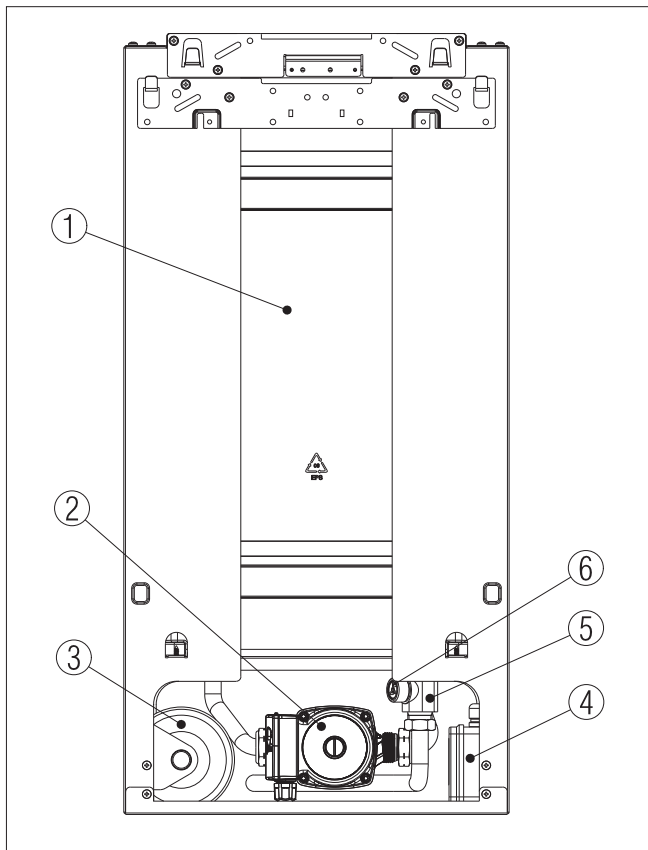

1. 31L wall-hung DHW BI-TANK
2. Circulator
3. DHW expansion vessel
4. Electronics kit
5. Valve
6. Check valve

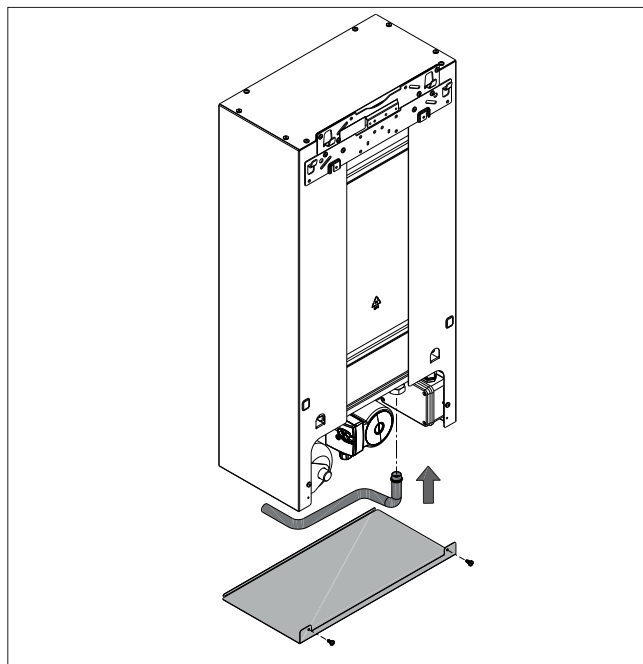

### WIRING DIAGRAM

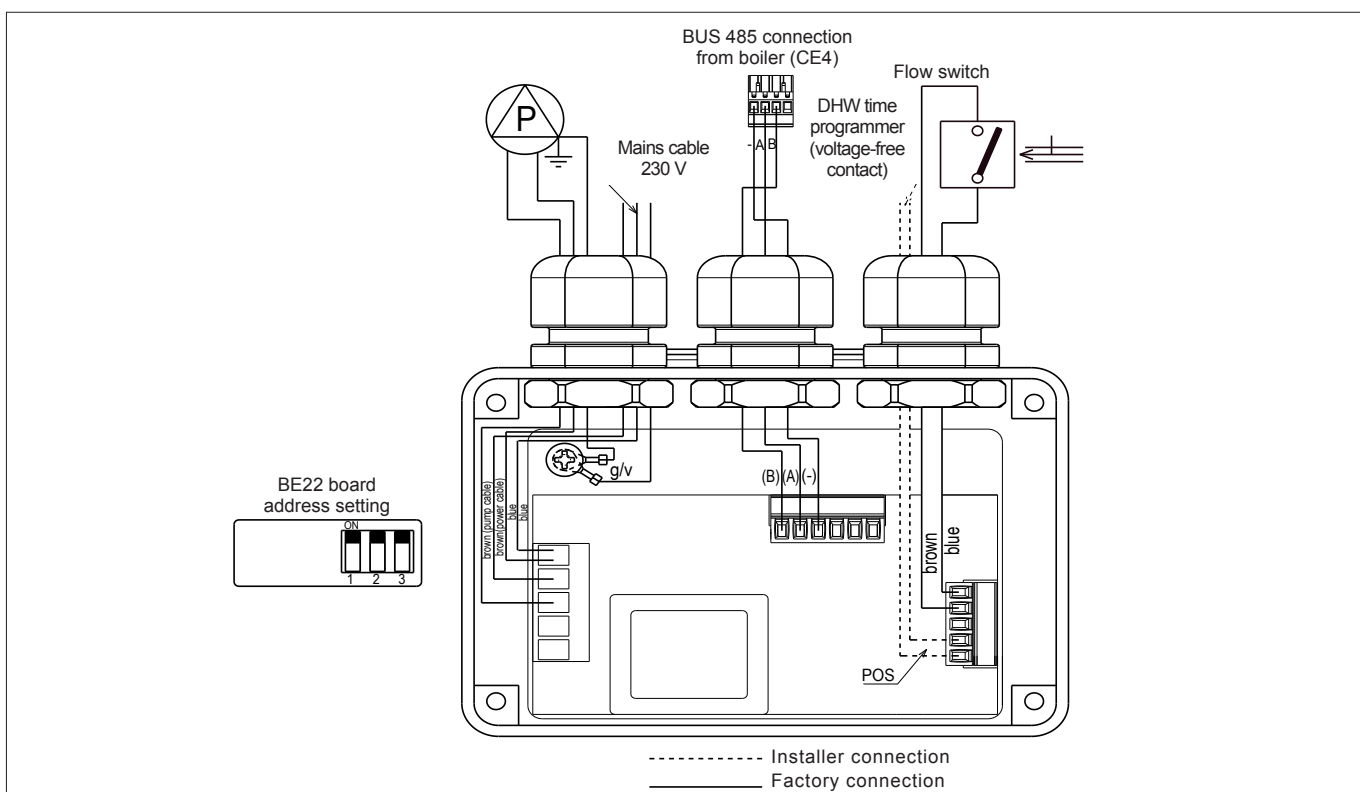

## WALL-HUNG CONDENSING BOILERS

Wall-hung condensing boilers with DHW bi-tank

### HYDRAULIC CIRCUIT

DHW BI-TANK

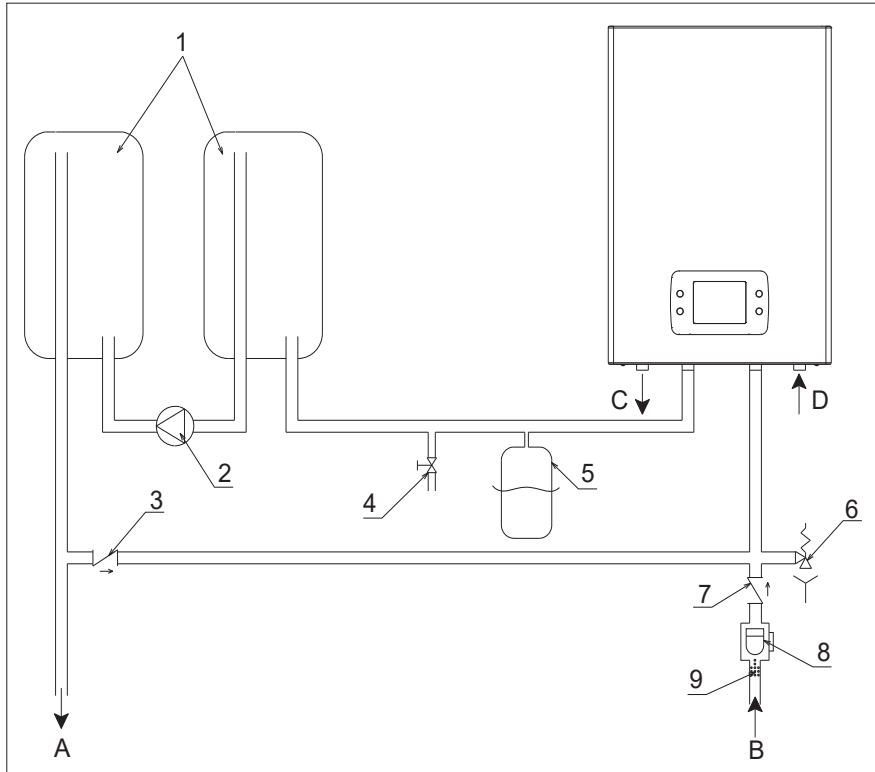

REF.	DESCRIPTION
A	Hot water outlet
B	Cold water inlet
C	Heating flow
D	Heating return
1	31L DHW BI-TANK
2	Domestic water pump
3	Check valve
4	Drain tap
5	Domestic water expansion vessel
6	Safety valve
7	Check valve
8	Flow switch
9	Domestic water filter

### INSTALLATION

DHW BI-TANK + RESIDENCE AQUA 25 BIS

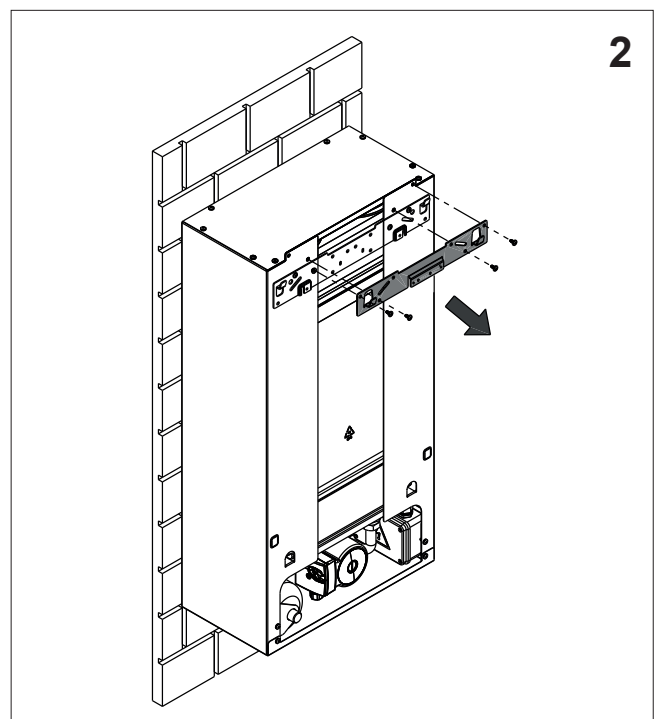
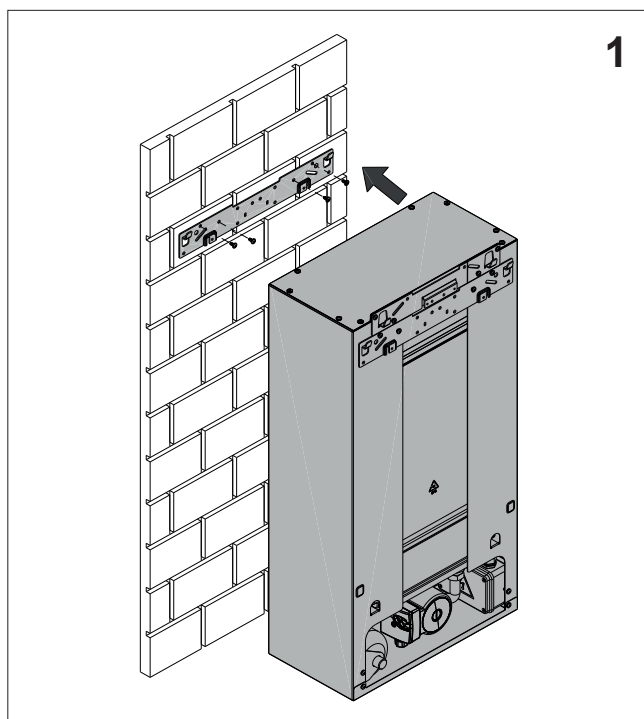

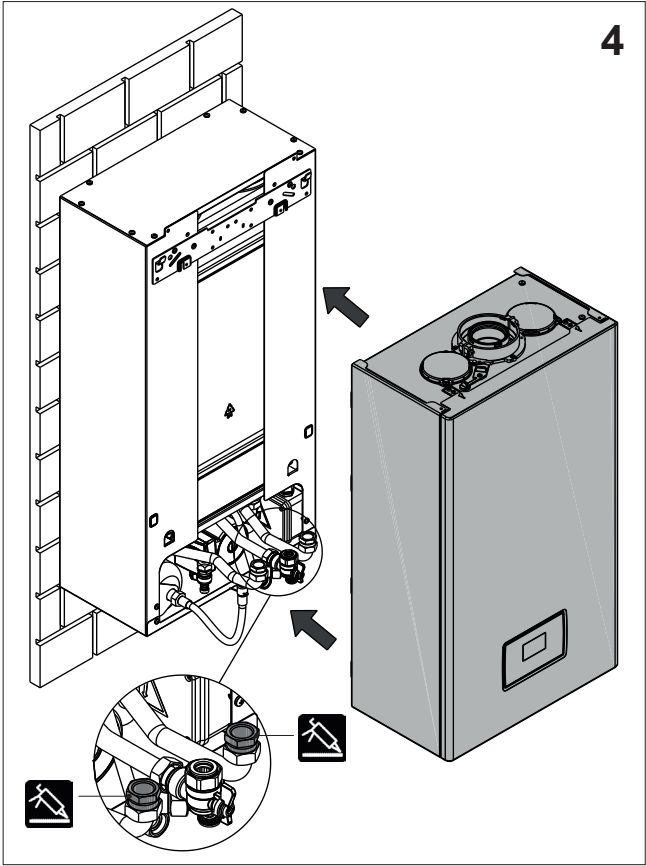
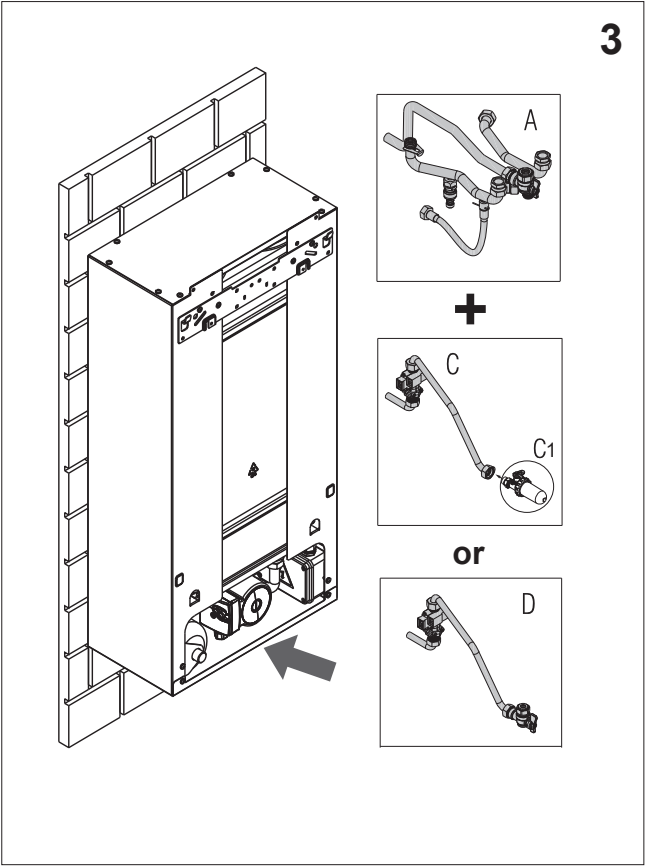

**ELECTRICAL CONNECTIONS**

FACTORY CONFIGURATION – CIRCULATOR CONNECTION

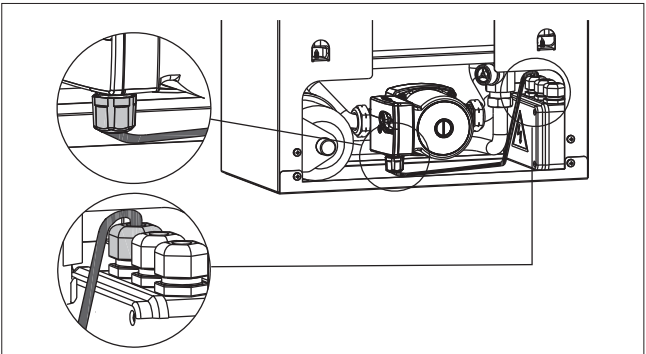

FACTORY CONFIGURATION – FLOW SWITCH CONNECTION

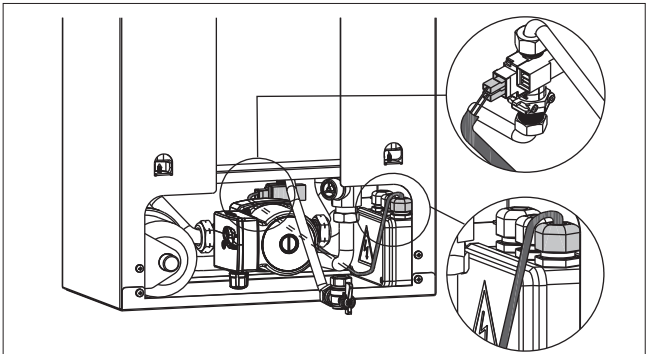

REMOVE THE 4-WAY CONNECTOR LOCATED UNDER THE BOILER SHELF

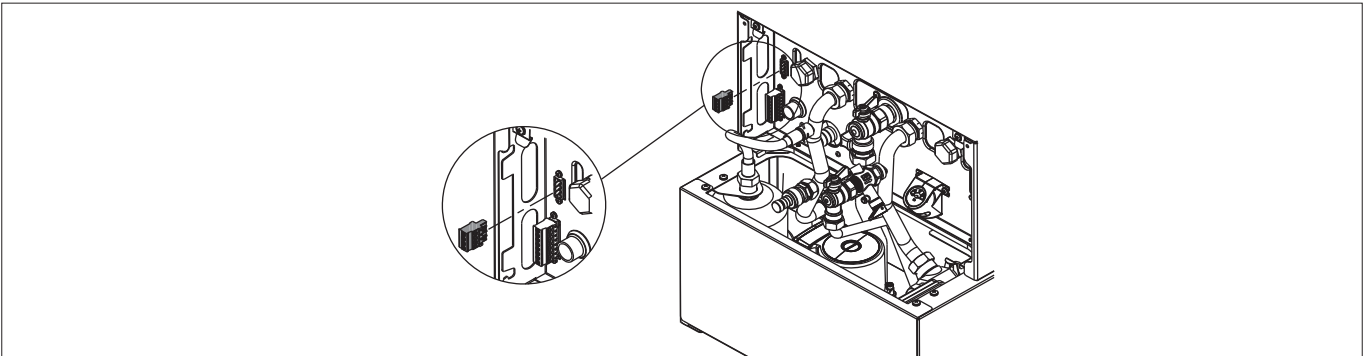

## WALL-HUNG CONDENSING BOILERS

Wall-hung condensing boilers with DHW bi-tank

CONNECT BUS 4-85 SIGNAL CABLE

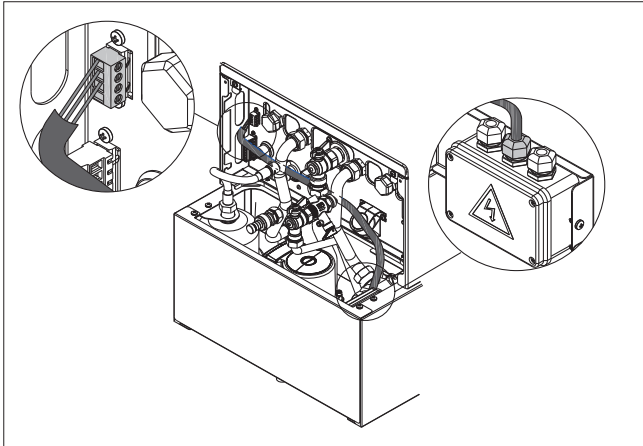

CUT THE CABLE POPPET WITH SCISSORS

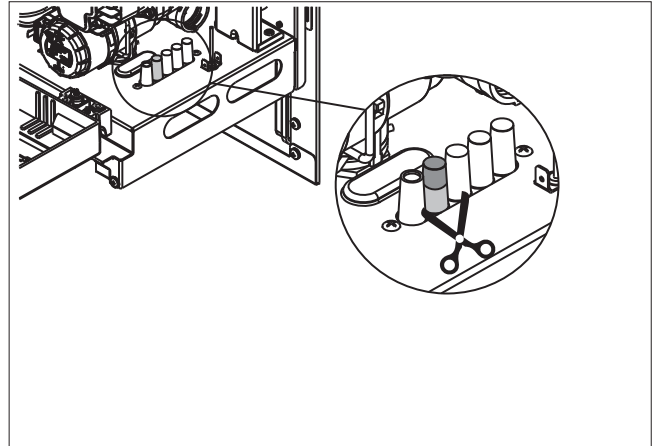

CONNECT DOSSERET POWER CABLE TO BOILER

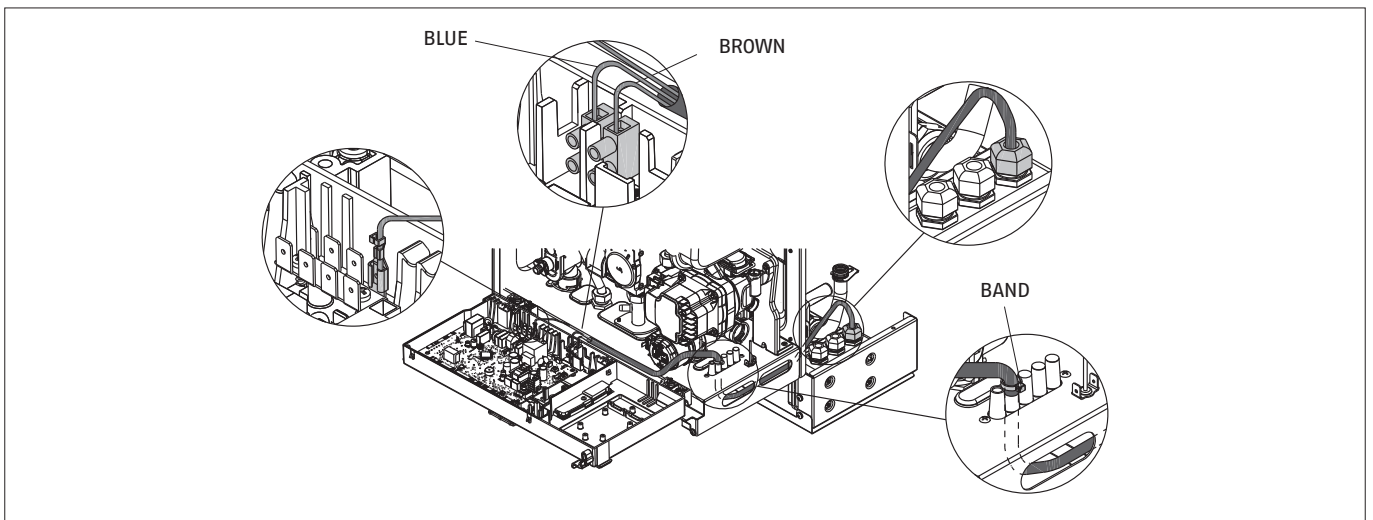

APPLY THE BOTTOM COVER

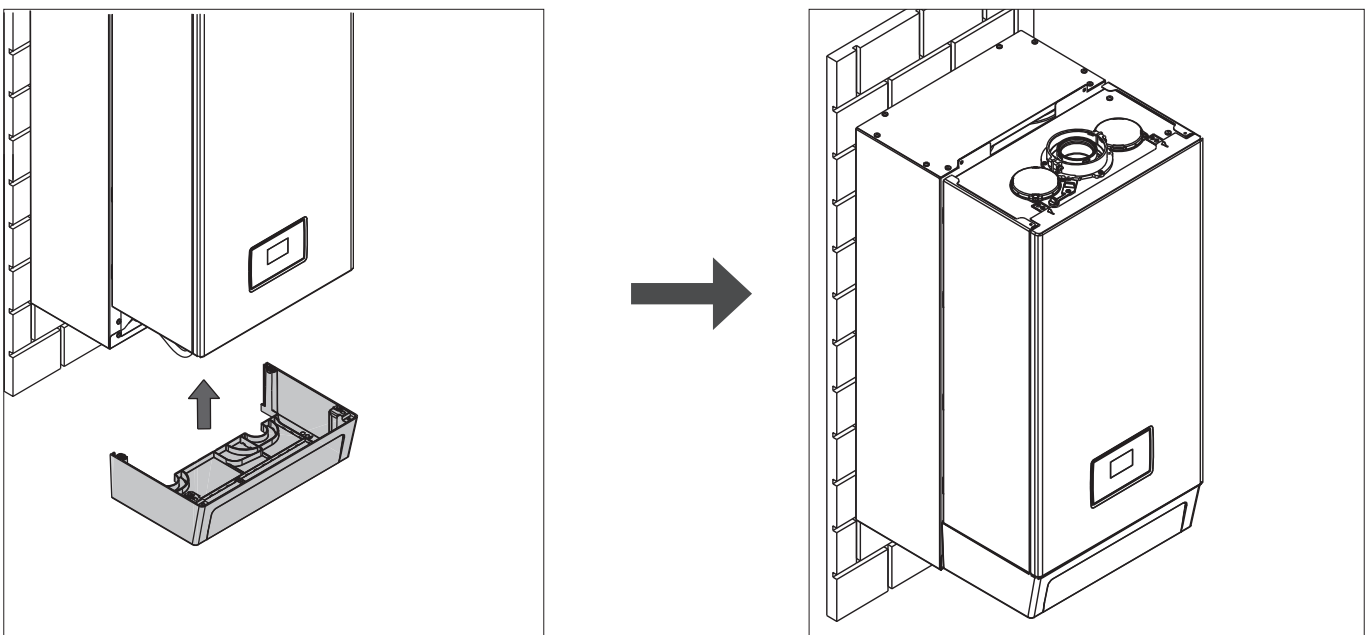

## CONTROL PANEL RESIDENCE AQUA 25 BIS

RESIDENCE AQUA 25 BIS

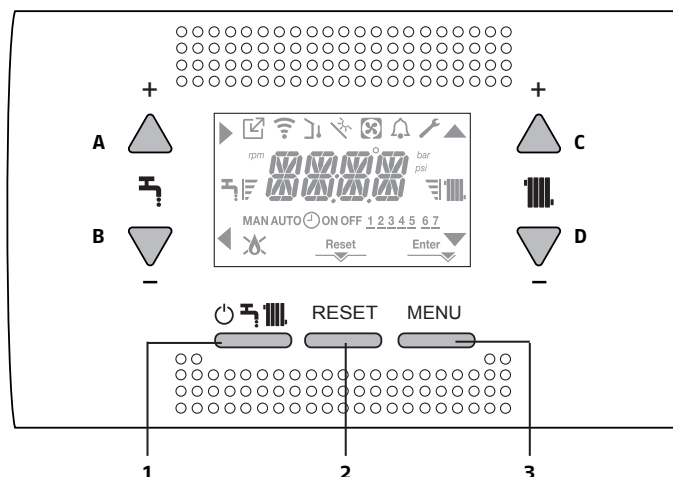

## Key Functionality

<b>A</b>	It is normally used to increase the domestic hot water temperature value, when the arrow ► is highlighted it performs the confirmation function instead.
<b>B</b>	It is normally used to decrease the domestic hot water temperature value, when the ◀ arrow is highlighted it performs the back/cancel function.
<b>A+B</b>	Access to the health comfort functions and activation of the Bottle function (allows you to lock the value set in the health setpoint, preventing anyone from inadvertently modifying it).
<b>C</b>	It is normally used to increase the heating water temperature value, when the ▲ arrow is highlighted it allows you to move within the P1 menu.
<b>D</b>	It is normally used to decrease the heating water temperature value, when the ▼ arrow is highlighted it allows you to move within the P1 menu.
<b>A+C</b>	Access to the clock setting menu.
<b>1</b>	Used to change the boiler operating status (OFF, SUMMER and WINTER).
<b>2</b>	Used to reset the alarm status or to interrupt the venting cycle.
<b>3</b>	Used to access the INFO and P1 menus. When the icon shown on the display Enter, the key assumes the function of ENTER and is used to confirm the value set during the programming of a technical parameter.
<b>1+3</b>	Lock and unlock keys.
<b>2+3</b>	When the boiler is in OFF state it is used to activate the combustion analysis function (CO).

The control panel has the function of boiler interface, displays the settings related to the system and allows access to the parameters.

The display normally shows the temperature of the sent probe unless a request for domestic water is in progress, in which case the DHW probe temperature is displayed; after 10 seconds without touching any key, the interface displays the current time (backlight off).

The configuration MENU is organized according to a multilevel tree structure. An access level has been defined for each submenu: USER level always available; TECHNICAL level protected by password. Below we summarize the structure of the SETTINGS MENU tree. Some of the information may not be available depending on the access level, the boiler status or the system configuration.



## Description of icons

	Indicates connection to a remote device (OT or RS485).
	Indicates connection to a WIFI device.
	Indicates the presence of an outdoor probe.
	Indicates activation of special DHW functions.
	An icon that lights up in the event of an alarm.
	It lights up in the event of an anomaly together with the icon  with the exception of the flame and water alarms.
	Indicates the presence of a flame; in the event of a flame block, the icon  appears.
	It lights up when there are alarms that require manual unlocking by the operator.
	It lights up when a confirmation operation is required.
	When the icon is active, it indicates that the "confirm" function of the A key is active.
	When the icon is active, it indicates that the "back/cancel" function of the B key is active.
	When the icon is active, it is possible to navigate the menu or increase the value of the selected parameter.
	When the icon is active, it is possible to navigate the menu or decrease the value of the selected parameter.
	The icon lights up if heating is active, it flashes if heating is requested.
	The icon lights up if domestic hot water is active, it flashes if domestic hot water is requested.
	They indicate the setpoint level set (1 = minimum value notch, 4 = maximum value notches).
<b>1 2 3 4 5 6 7</b>	Indicates the days of the week.
<b>AUTO</b>	Not available on this model.
<b>MAN ON</b>	Not available on this model.
<b>MAN OFF</b>	Not available on this model.



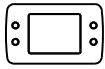
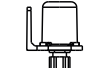
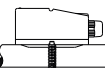
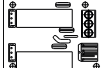

## WALL-HUNG CONDENSING BOILERS

Wall-hung condensing boilers with DHW bi-tank

### ACCESSORIES

Ref.	Connections	Description
	X6	Antifreeze Resistance L-N
	CE8	TA: (room thermostat)
	CE8	OT+
	CE8	SE: outdoor probe
	CE8	TBT: Low temperature thermostat
	X2	Alarm remote control
	X21	Zone valve or additional pump

### ACCESSORIES – ENVIRONMENTAL CONTROL Hi, Comfort (\*)

Ref.	Description
	<b>Hi, Comfort T100 Wi-Fi.</b> Complete kit for Wi-Fi installation, containing Hi, Comfort T100 and Hi, Comfort G100-W room control. The package also includes batteries, connection cables, transformer, screws, wall plugs, double-sided tape, magnetic adhesive and technical manual. ErP Contribution Class: VI-4% (**); I-1% (**).
	<b>Hi, Comfort T100.</b> Hi, Comfort T100 room control intended for replacement or new installations, both with single zone or for expansions for Multi-zone applications. Hi, Comfort T100 is compatible for Internet connection in combination with Hi, Comfort G100-W (optional). The package also includes batteries, screws, wall plugs, double-sided tape and technical manual. ErP Contribution Class: V-3%(**); I-1% (**).
	<b>Hi, Comfort G100-W.</b> Hi, Comfort G100-W is the device that allows connection to the Internet through the home Wi-Fi network. It also allows connection to the boiler OTBus for advanced remote management. The package also includes: connection cables, transformer, magnetic sticker.
	<b>Hi, Comfort G100-R.</b> Radio frequency device that allows wireless connection of the Hi, Comfort T100 control to the boiler (both ON-OFF and via OTBus). It can also be used in cases where the weakness of the Wi-Fi signal does not allow connecting the Hi, Comfort G100-W near the boiler.

(\*) Modulating room controls with remote boiler interface function (Possibility of connection in ON/OFF only on BAG3 HYBRID) and possibility of management via APP.

(\*\*) With connection via OTBus.

(\*\*\*) In on/off management.

(1) With Hi, Comfort G100-W included for connection to the Internet via home ADSL Wi-Fi modem.

(2) For cable connection to the boiler. Compatible for radio-frequency connection with Hi, Comfort G100-W (accessory not included and necessary for connection to the Internet via home ADSL modem) and compatible with Hi, Comfort G100-R.

## RESIDENCE AQUA 25 BIS

### CONSTRUCTION DESCRIPTION FOR SPECIFICATIONS

RESIDENCE AQUA 25 BIS is a wall-hung condensing boiler for heating and domestic hot water production: depending on the flue accessory used, it is classified in the categories B23P; B53P; C(10)3; C13,C13x; C33,C33x; C43,C43x; C53,C53x; C63,C63x; C83,C83x; C93,C93x.

Wall-hung condensing boilers, with primary exchanger in AISI 441 stainless steel and pneumatic combustion system that guarantees functionality, efficiency and low emissions in all circumstances. 1:8 modulation across the entire range.

RESIDENCE AQUA 25 BIS stands out for its compactness (only 249 mm deep), application flexibility and wide availability of accessories that guarantee compatibility and backward compatibility even in the smallest Riello boxes.

### CHARACTERISTICS

The boilers of the RESIDENCE AQUA 25 BIS range are heat generators characterised by:

- Pneumatic combustion system that guarantees, in all circumstances, functionality, efficiency and low emissions; designed to operate with natural gas LPG and with mixtures of natural gas and up to 20% hydrogen. The models are also approved to work with propane air.
- Maximum heat output adjustable to the thermal needs of the system, for heating operation of the boiler itself. Once the desired power has been set (maximum heating), report the value and, for subsequent checks, refer to the new value (Range Rated).
- High-efficiency modulating circulator already connected hydraulically and electrically, which is factory-set with a 6-meter head curve; available as a 7-meter circulator accessory. Modulation occurs proportionally to the power supplied by the burner.
- Anti-lock system that starts an operating cycle every 24 hours of inactivity with the function selector in any position.
- Circular main exchanger in AISI 441 stainless steel.
- Brazed plate DHW exchanger designed and manufactured in RIELLO with high efficiency that allows the production of domestic hot water in condensation mode and with maximum stability.
- Premix burner with low polluting emissions Class 6 NO<sub>x</sub>, according to UNI EN 15502-1, fan, high modulation mixer and gas diaphragm. Available as an accessory kit with non-return valve (clapet) for connection to positive pressure flue systems.
- Available as an accessory kit for air filtering integrated into the boiler consisting of a filter in elastic and break-resistant polyolefin fibres.
- Hydraulic connections with sequence of RIELLO type connections and specific accessories in case of replacement with old boilers and built-in boxes.
- Filling tap, deaeration tap.
- Siphon with safety ball inside the boiler footprint.
- Drain valve.
- Pressure transducer.
- Safety valve.
- Return probe, flue gas probe, and flow probe.
- Automatic antifreeze system, which is activated when the water temperature of the primary circuit drops below 5°C. This system is always active and guarantees boiler protection up to an air temperature in the installation location of 0°C.
- Limit thermostat.
- Single electrode for ignition and flame detection.
- Ignition transformer.
- Equipped with flue gas analysis socket cap.
- 8-liter expansion vessel.
- Three-way hydraulic valve (stepper).
- Manual filling valve.
- Hydrometer.
- Lower air vent valve.
- Control panel with boiler interface function, and displays the system settings and makes it possible to access the parameters. The main screen shows, in the central position, the temperature of the domestic hot water probe unless there is a heat request in progress, in which case the boiler flow temperature, the water pressure in the system, and the information relating to the current date and time are displayed, and, if available, the value of the outdoor temperature detected.
- OT+ inlet as standard.
- RESIDENCE AQUA 25 BIS is compatible with all Hi, Comfort products.

# RIELLO

RIELLO S.p.A.  
37045 Legnago (VR) ITALY  
tel. +39 0442 630111

[www.riello.com](http://www.riello.com)



RESIDENCE AQUA

RIELLO reserves the right to change the information and specifications contained herein at any time and without notice. The contents and information provided herein are for informational purposes only and are not intended to provide legal or professional advice. This document, therefore, cannot be considered binding on third parties.



©2025 Carrier. All Rights Reserved.  
All trademarks and service marks referred herein  
are property of their respective owners.