

RESIDENCE HM AQUA

NEW



Wall-hung condensing boilers with stainless steel DHW tank

RESIDENCE HM AQUA

RIELLO INTRODUCES RESIDENCE HM AQUA, THE CONDENSING BOILER WITH A 30-LITRE DHW BI-TANK, DESIGNED TO OFFER EFFICIENCY AND ENERGY SAVINGS.

RESIDENCE HM AQUA (25 and 35 BIS) stands out with its **greater compactness and efficiency compared to previous Riello boiler ranges** with integrated DHW tank.

RESIDENCE HM AQUA contains a **30-litre stainless steel bi-tank** which, in addition to saving space, improves energy efficiency. The range also offers **excellent heating comfort** thanks to an efficient pneumatic combustion stainless steel heat exchanger and wide 1:10 modulation.

Its elegant, minimalist design, combined with ease of use, allows the product to **adapt easily to various residential environments, both in new buildings and renovations.**

RESIDENCE HM AQUA, in line with Riello's new generation products, pays particular attention to the environment. It has **very low NOx emissions**, classifying it in class 6 according to European standards. **It is designed with a look towards the future: it is already suitable to operate with blends of natural gas and hydrogen up to 20%**, an important step in the decarbonization process initiated by the European Union.



STAINLESS STEEL
HEAT EXCHANGER



30L STAINLESS STEEL
BI-TANK



LOW NOx EMISSIONS
(CLASS 6)



HOT WATER
AT A STABLE TEMPERATURE

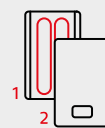

EASY INSTALLATION
IN TWO STEPS



SIMPLIFIED MAINTENANCE WITH
FRONT ACCESS

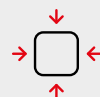

COMPACT
DIMENSIONS



NEW ADAPTIVE ELECTRONIC COMBUSTION CONTROL

The RESIDENCE HM AQUA range is equipped with the new ACC (Active Combustion Control) intelligent combustion control system, which automatically adapts to the fuel (natural gas, LPG, etc.) without the need for specific codes or accessory conversion kits. This innovative and sophisticated control system allows for self-adjustment of combustion, eliminating the need for initial calibration. The ACC system is also able to adapt the boiler to operate with different gas configurations, different pipe lengths and at different altitudes (within the design limits). In addition, the new adaptive system is able to perform self-diagnosis for combustion that is always under control, with emissions consistently well below the limits imposed by regulations.



Increase and decrease in temperature of DHW

Navigation directions ↕

Navigation directions ↕

Increase and decrease in temperature of HEATING



Selecting operating modes (OFF/SUMMER/WINTER)

INFO-INPUT-MENU

RESET of any alarm status/interruption of the venting cycle

TECHNOLOGY FOR HOME COMFORT

RESIDENCE HM AQUA consists of two elements that make up a system: the boiler and the DHW bi-tank. Installation is extremely simple and can be summarized in **TWO STEPS: mounting the storage tank on the wall and mounting the boiler on the DHW tank.**

NEW 30 L BI-TANK WITH ADVANCED ELECTRONICS



STEP 1: INSTALLATION OF THE DHW BI-TANK ON THE WALL

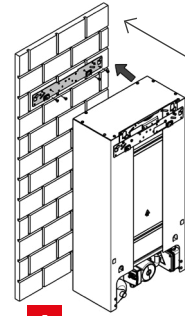

After fixing the template, the DHW bi-tank can be mounted on the wall

A

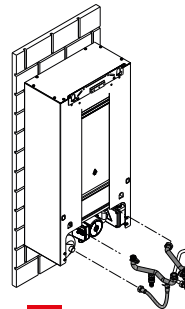

After fixing the boiler template onto the DHW bi-tank, the hydraulic kit and flow switch can be installed (available as accessories)

B

- The DHW bi-tank (also known as dossier) achieves the same **performance as the tank of the previous Riello START AQUA CONDENS MODEL, with 45 and 60 litres capacity, with more compact dimensions**
- **Possibility of managing the refilling frequency of the tank** via a parameter in the electronics:
 - **COMFORT:** for longer and more frequent filling cycles, if withdrawals are frequent or the volume of water required is high
 - **ECO:** for a reduced number of filling cycles and consequently greater energy savings
- **Expansion vessel of the DHW bi-tank**
- **DHW bi-tank supplied separately from the boiler**

STEP 2: BOILER INSTALLATION ON THE BI-TANK

After fixing the boiler to its template, the hydraulic connections between the DHW bi-tank, the boiler and the electrical connection can be completed

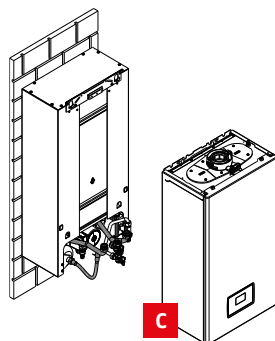

Mounting of the lower cover fittings at the end of installation

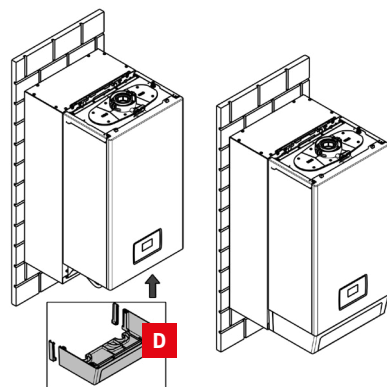

- **New flue gas flange** with quick-tightening safety collar
- **Low NOx emissions:** class 6 (uni en 15502)
- **Energy efficiency:** 94%
- **1:10** modulation
- **9-litre expansion vessel**
- **Low consumption modulating circulator** ($eei \leq 0,20$), with a 6-meter head curve
- **Very low noise** operation
- Electrical level of protection **IPX5D**
- Hydraulic unit with DIN connections sequence
- **Can be combined with Hi, Comfort T100 for remote comfort management**
- **Boiler supplied separately from the DHW bi-tank**

+ 25% heat input* compared to the average of Riello boilers with instantaneous DHW production.

CONDENSING BOILER TO BE COMBINED WITH THE BI-TANK

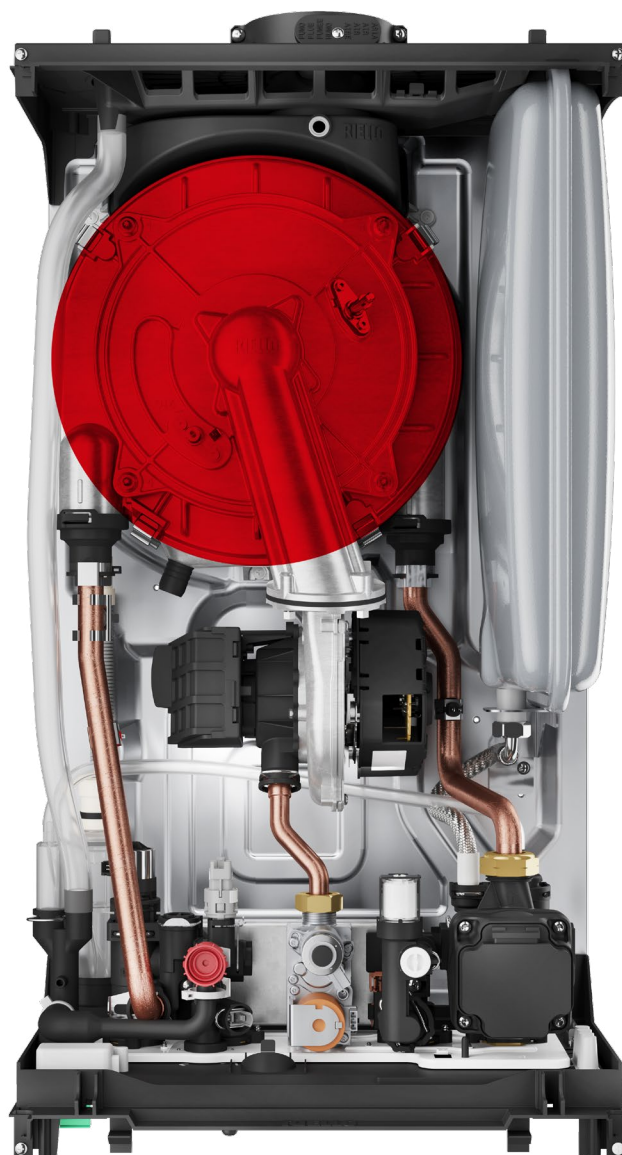

* Internal comparison with Riello's instantaneous combi boiler models of the same heat output.

TECHNICAL DRAWINGS

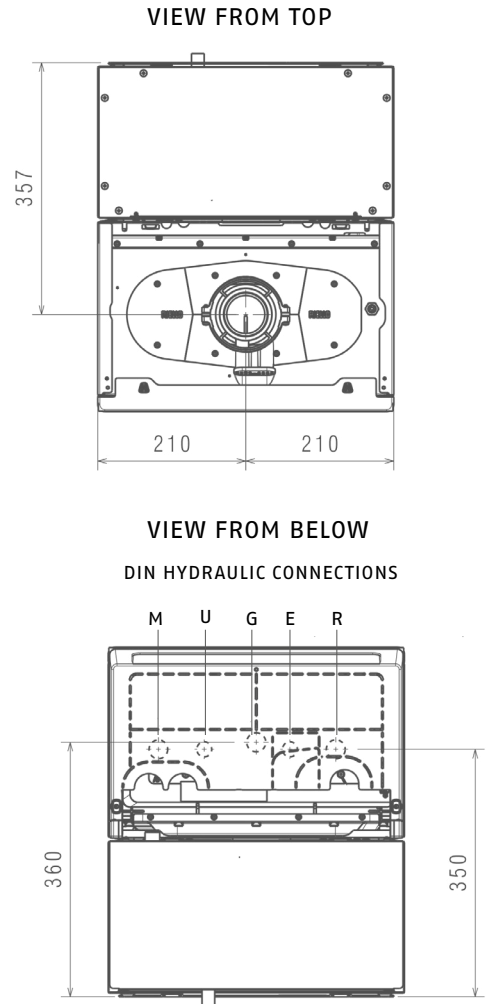
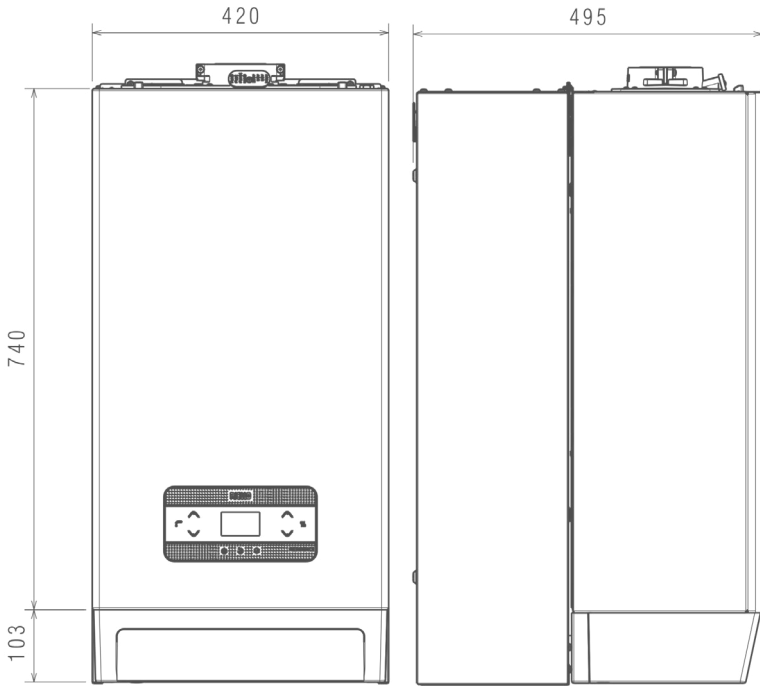

R RETURN
E DCW INLET
G GAS
U DHW OUTLET
M FLOW

FLUE OPTIONS

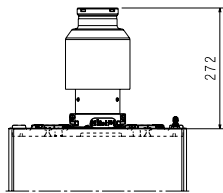

B23P_B53P
FLUES TYPE

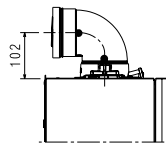

Ø60-100
CONCENTRIC FLUES

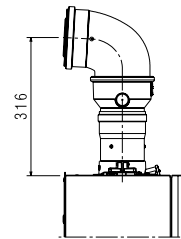

Ø80-125
CONCENTRIC FLUES

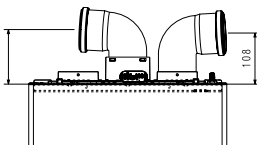

Ø80-80
TWIN FLUES

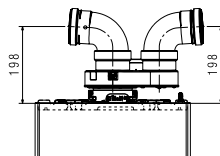

Ø80-80
TWIN FLUES WITH ADAPTER

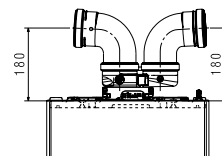

Ø80-80
TWIN FLUES WITH COMPACT ADAPTER

TECHNICAL DATA

 ENERGY LABEL SPECIFICATIONS (in accordance with the ErP Directive)	UoM	RESIDENCE HM	RESIDENCE HM	
		AQUA 25 BIS	AQUA 35 BIS	
Seasonal energy efficiency class for heating	D → A+++ ⁽¹⁾	A	A	
Domestic water seasonal energy efficiency class	F → A+ ⁽²⁾	A	A	
Nominal power according to ErP	pnominal	kW	20	29
Heating seasonal energy efficiency	ηs	%	94	94
USEFUL HEAT OUTPUT				
At rated heat output and at high temperature operation *	P4	kW	19,5	29,3
At 30% nominal heat output and at low temperature **	P1	kW	6,6	9,9
USEFUL EFFICIENCY				
At rated heat output and at high temperature operation *	η4	%	87,9	87,9
At 30% nominal heat output and at low temperature **	η1	%	98,8	98,8
AUXILIARY ELECTRICAL CONSUMPTION				
At full load	elmax	W	30,0	44,3
At partial load	elmin	W	12,2	13,6
In stand-by mode	PSB	W	3,0	3,0
OTHER PARAMETERS				
Thermal losses in stand-by mode	Pstby	W	30,0	35,0
Yearly energy consumption	QHE	GJ	60,0	90,0
Sound power level, indoor	LWA	dB	48,0	47,0
NOx emissions	NOx	mg/kWh	22,0	35,0
FOR COMBINED HEATING APPLIANCES – BOILER WITH DOSSERET				
Declared load profile			XL	XL
DHW energy efficiency	ηwh	%	85	87
Daily electrical energy consumption	Qelec	kWh	0,173	0,102
Daily fuel consumption	Qfuel	kWh	23,014	22,524
Yearly electrical energy consumption	AEC	kWh	38	22
Annual fuel consumption	AFC	GJ	17	17
OTHER TECHNICAL SPECIFICATIONS				
Heating heat input (max-min G20)		kW	20,0 – 2,5	30,0 – 3,5
Nominal DHW heat input (max-min G20)		kW	25,0 – 2,5	34,9 – 3,5
Power supply		V-Hz	230 – 50	230 – 50
Electrical protection level		IP	IPX5D	IPX5D
NOx class			6	6
HEATING				
Pressure - max temperature		bar - °C	3 – 90	3 – 90
Pump: maximum available head (at flow rate of 1000 l/h)		mbar	450	450
Membrane expansion tank		l	9	9
DOMESTIC WATER				
Max pressure		bar	8	8
DHW production at ΔT=25°C / 30°C / 35°C		l/min	14,3/11,9/10,2	20,0/16,7/14,3
Minimum DHW flow		l/min	2	2
GAS, HYDRAULIC CONNECTIONS				
Nominal gas pressure (G20-G31)		mbar	20 – 37	20 – 37
Heating flow-return/Gas inlet		∅	3/4 "	3/4 "
DHW inlet-outlet/Boiler flow-return		∅	1/2 "	1/2 "
WEIGHT				
Net weight of boiler		kg	29	30
Net weight of tank		kg	18,6	18,6
FLUE GAS SYSTEMS				
Max length for concentric flue gas (∅60-100 mm)		m	10	10
Max length for twin flue gas (∅80-80 mm)		m	75+75 (A)	39+39 (B)

VALUES RELATING TO DHW PERFORMANCE WITH BOILER WHEN INSTALLING THE DOSSERET KIT

	∅	Stainless steel	Stainless steel
Type of tank	∅	Vertical	Vertical
Tank layout	∅	External plate	External plate
Heat exchanger layout	∅	31	31
Vnom, effective domestic hot water content	l	37-60	37-60
Domestic hot water temperature selection range	°C	119	167
Water quantity drawn in 10 minutes with minimum ΔT 30°C	l	10	10
Maximum boiler operating pressure	bar	31	31
Vbu, non-solar storage volume	l	14,3	18,1
Specific flow rate according to EN13203-1	l/min		

(1) The energy efficiency class range for this product category is between D and A+++

(2) The energy efficiency class range for this product category is between F and A+

* High temperature mode: 60°C in the boiler return and 80°C in the boiler flow.

** Low temperature mode: for condensing boilers 30°C, for low temperature boilers 37°C, for other heating appliances 50°C return temperature.

(A) Up to 69+69m with twin flues compact adapter

(B) Up to 36+36m with twin flues compact adapter

RIELLO

RIELLO S.p.A.
Via Ing. Pilade Riello, 7
37045 Legnago (VR) - Italy
tel. +39 0442 630111
www.riello.com



RESIDENCE HM AQUA



Code 27024030 - EN - 06/2025



©2025 Carrier. All Rights Reserved.
All product and service marks mentioned in this document
are the property of their respective owners.

Riello reserves the right to change the information and specifications
contained herein at any time and without notice. The contents and
information provided herein are for informational purposes only and
are not intended to provide legal or professional advice. This document,
therefore, cannot be considered binding on third parties.