

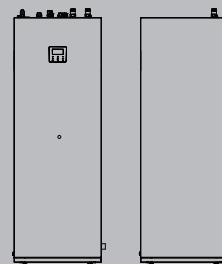

DOMUS M

Floor-standing split heat pump

Split heat pump with floor standing indoor unit for heating, cooling and domestic hot water (DHW) production
Wide range of powers available, from 4 up to 16 kW
R32 refrigerant



HEAT PUMPS

Floor-standing split heat pump

INDEX

Product description	3
Technical data	4
ERP technical data	12
Performance data	16
Operating limits	26
Sound pressure levels	27
Overall dimensions and weights	46
Structure.	50
Hydraulic and refrigeration connections	51
Hydraulic system.	55
Wiring	56
Control panel	60
Main accessories	61
Construction description for specifications	68

PRODUCT DESCRIPTION

Domus M is a floor-standing split heat pump system for heating, cooling and domestic hot water production. The system consists of an outdoor unit with R32 refrigerant connected through refrigerant pipes to the indoor floor-standing unit.

The outdoor unit, compact and quiet, includes a Twin Rotary DC inverter compressor, electronic expansion valve, fans with brushless motor and finned pack coil optimized for heat pump operation even with outdoor air temperature of -25°C.

The main components of the hydronic system are located in the indoor unit, including a cylinder of 190l or 240l with high-surface for domestic hot water production.

- All-in-One floor-standing indoor unit for clean and tidy installation.
- 190-liter or 240-liter cylinder for production of DHW.
- Compact indoor unit, only 600x600mm footprint dimensions
- Hydraulic, electrical and refrigeration connections from above
- Front access to all components for easy installation and service
- Equipped with 3kW or 2/4/6kW or 3/6/9 kW back-up heater, depending on the models, offering stable performance
- Simple and intuitive control panel with large display and available in multi-languages

Indoor unit		Heater capacity	Outdoor unit										
			MONOPHASE						THREE-PHASE				
			230V / 1N / 50Hz						400V / 3N / 50Hz				
			004	006	008	010	012	014	016	12T	14T	16T	
M61	190L	6kW / 1ph ⁽¹⁾	●	●	●	●	-	-	-	-	-	-	
L61	240L	6kW / 1ph ⁽¹⁾	●	●	●	●	-	-	-	-	-	-	
L61	240L	6kW / 1ph ⁽¹⁾	-	-	-	-	●	●	●	-	-	-	
L93	240L	9kW / 3ph ⁽²⁾	-	-	-	-	-	-	-	-	●	●	●

● Available

- Not available

(1) Default setting as 4kW/ 1ph, configurable on-site to either 2kW/ 1ph or 6kW/ 1ph

(2) Default setting as 9kW/ 3ph, configurable on-site to either 3kW/ 3ph or 6kW/ 3ph

HEAT PUMPS

Floor-standing split heat pump

TECHNICAL DATA

DESCRIPTION	NOTES	U.M.	DOMUS M			
Outdoor unit			HP EXTERNAL UNIT R32			
			004	006	008	010
Indoor unit			HP IDU DOMUS			
			M61			
HEATING PERFORMANCE DATA						
Heating performance (A7°C; W35°C)						
Nominal capacity		kW	4,25	6,20	8,30	10,00
Absorbed power		kW	0,82	1,24	1,60	2,00
COP			5,20	5,00	5,20	5,00
SCOP			4,85	4,95	5,21	5,19
Seasonal energy efficiency		%	191	195	205	205
Energy class		D → A+++ (*)	A+++	A+++	A+++	A+++
Heating performance (A7°C; W45°C)						
Nominal capacity		kW	4,35	6,35	8,20	10,00
Absorbed power		kW	1,14	1,69	2,08	2,63
COP			3,80	3,75	3,95	3,80
Heating performance (A7°C; W55°C)						
Nominal capacity		kW	4,40	6,00	7,50	9,50
Absorbed power		kW	1,49	2,00	2,36	3,06
COP			2,95	3,00	3,18	3,10
SCOP			3,31	3,52	3,36	3,49
Seasonal energy efficiency		%	130	138	132	137
Energy class		D → A+++ (*)	A++	A++	A++	A++
COOLING PERFORMANCE DATA						
Cooling performance (A35°C; W7°C)						
Nominal capacity		kW	4,70	7,00	7,40	8,20
Absorbed power		kW	1,36	2,33	2,19	2,48
EER			3,45	3,00	3,38	3,30
SEER			4,99	5,34	5,83	5,98
Seasonal energy efficiency		%	196	210	229	235
Cooling performance (A35°C; W18°C)						
Nominal capacity		kW	4,50	6,55	8,40	10,00
Absorbed power		kW	0,81	1,34	1,66	2,08
EER			5,55	4,90	5,05	4,80
DHW PERFORMANCE DATA						
Domestic hot water boiler volume		l	190	190	190	190
Boiler material			Stainless steel	Stainless steel	Stainless steel	Stainless steel
Maximum domestic hot water pressure		bar	10,00	10,00	10,00	10,00
Domestic hot water seasonal energy efficiency – Temperate zone		%	127	127	125	125
Domestic hot water energy class		F → A+ (*)	A+	A+	A+	A+
COP Outdoor air +7°C (EN16147)			3,10	3,10	3,02	3,02
Heating time (10–48°C) with outdoor air 7°C		hour-min	1h47	1h47	1h38	1h38
Heating time (37–48°C) with outdoor air 7°C		hour-min	0h33	0h33	0h28	0h28
Quantity of water delivered at 40°C with a flow rate of 10 l/min		l	200	200	200	200
ELECTRICAL CHARACTERISTICS						
Electrical power supply		V/ph/Hz	230/1/50	230/1/50	230/1/50	230/1/50
Maximum total input current	1	kW	2,20	2,60	3,30	3,60
Maximum total input current	2	A	12,00	14,00	16,00	17,00
COMPRESSOR						
Compressor		Type/brand	Twin Rotary/ Mitsubishi	Twin Rotary/ Mitsubishi	Twin Rotary/ Mitsubishi	Twin Rotary/ Mitsubishi
Adjustment		Type	DC Inverter	DC Inverter	DC Inverter	DC Inverter
Minimum partialisation (A7°C; W35°C)		%	55%	44%	40%	38%
Refrigerant		Type	R32	R32	R32	R32
GWP			675	675	675	675
Refrigerant charge		kg	1,50	1,50	1,65	1,65

DESCRIPTION	NOTES	U.M.	DOMUS M			
Outdoor unit			HP EXTERNAL UNIT R32			
			004	006	008	010
Indoor unit			HP IDU DOMUS			
			M61			
CO ₂ equivalent		tons	1,01	1,01	1,11	1,11
Number of circuits		n.	1	1	1	1
Hermetically sealed control box (EU Reg. 573/2024)		yes/no	no	no	no	no
FAN						
Fan		Type	Axial	Axial	Axial	Axial
Quantity		n.	1	1	1	1
Maximum air flow		m ³ /h	2770	2770	4030	4030
Useful head		Pa	-	-	-	-
AIR-SIDE HEAT EXCHANGER						
Air-side heat exchanger		Type	Copper pipes, fins in hydrophilic aluminium with anti-corrosion treatment			
HYDRONIC MODULE						
Circulation pump		Type/adjustment	Variable speed centrifuge			
Nominal flow		m ³ /h	0,73	1,07	1,43	1,72
Useful head at nominal flow		Kpa	75	74	63	45
Maximum circulation pump absorbed power		W	90	90	90	90
Minimum circulation pump absorbed power		W	5	5	5	5
Calibration pressure of the safety valve		bar	3,0	3,0	3,0	3
Expansion reservoir volume		l	8	8	8	8
SYSTEM SIDE EXCHANGER						
System side exchanger		Type	With plates	With plates	With plates	With plates
Water content		l	5	5	5	5
NOISE LEVEL DATA						
Outdoor unit sound power	3	dB(A)	56	58	59	60
Outdoor unit sound pressure at 1m	4	dB(A)	44	45	46	49
Indoor unit sound power	3	dB(A)	38	38	40	40
Indoor unit sound pressure at 1 m	4	dB(A)	22	24	22	22
WEIGHT						
Outdoor unit net weight		kg	58	58	75	75
Indoor unit net weight		kg	140	140	140	140

NOTE

The performance is in accordance with standards UNI EN 14511 and UNI EN 14825.

- (1) Power absorbed by the outdoor unit at limit operating conditions and nominal supply voltage (for total system absorption add the power of the indoor units, with various supplementary heating elements, indicated in the electrical wiring section).
- (2) Maximum operating current of the unit at nominal supply voltage.
- (3) Declared noise emission values in accordance with EN 12102-1.
- (4) Measured in a semi-anechoic chamber, at a distance of 1m from the front of the unit and at a height from the floor equal to (1+H)/2, where H is the height of the unit expressed in metres (in accordance with standard EN 12102-1).
- (*) The energy efficiency class range of this product category is between D and A+++
- (**) The energy efficiency class range of this product category is between F and A+

The data contained in the boxes marked in grey are to be used for telematic transmission to ENEA for the purposes of tax deductions.

The data contained in the boxes marked in grey are to be used for the registration of the control box in the F-GAS database.

HEAT PUMPS

Floor-standing split heat pump

DESCRIPTION	NOTES	U.M.	DOMUS M			
Outdoor unit			HP EXTERNAL UNIT R32			
			004	006	008	010
Indoor unit			HP IDU DOMUS			
			L61			
HEATING PERFORMANCE DATA						
Heating performance (A7°C; W35°C)						
Nominal capacity		kW	4,25	6,20	8,30	10,00
Absorbed power		kW	0,82	1,24	1,60	2,00
COP			5,20	5,00	5,20	5,00
SCOP			4,85	4,95	5,21	5,19
Seasonal energy efficiency		%	191	195	205	205
Energy class		D → A+++ (*)	A+++	A+++	A+++	A+++
Heating performance (A7°C; W45°C)						
Nominal capacity		kW	4,35	6,35	8,20	10,00
Absorbed power		kW	1,14	1,69	2,08	2,63
COP			3,80	3,75	3,95	3,80
Heating performance (A7°C; W55°C)						
Nominal capacity		kW	4,40	6,00	7,50	9,50
Absorbed power		kW	1,49	2,00	2,36	3,06
COP			2,95	3,00	3,18	3,10
SCOP			3,31	3,52	3,36	3,49
Seasonal energy efficiency		%	130	138	132	137
Energy class		D → A+++ (*)	A++	A++	A++	A++
COOLING PERFORMANCE DATA						
Cooling performance (A35°C; W7°C)						
Nominal capacity		kW	4,70	7,00	7,40	8,20
Absorbed power		kW	1,36	2,33	2,19	2,48
EER			3,45	3,00	3,38	3,30
SEER			4,99	5,34	5,83	5,98
Seasonal energy efficiency		%	196	210	229	235
Cooling performance (A35°C; W18°C)						
Nominal capacity		kW	4,50	6,55	8,40	10,00
Absorbed power		kW	0,81	1,34	1,66	2,08
EER			5,55	4,90	5,05	4,80
DHW PERFORMANCE DATA						
Domestic hot water boiler volume		l	240	240	240	240
Boiler material			Stainless steel	Stainless steel	Stainless steel	Stainless steel
Maximum domestic hot water pressure		bar	10,00	10,00	10,00	10,00
Domestic hot water seasonal energy efficiency - Temperate zone		%	136	136	137	137
Domestic hot water energy class		F → A+ (*)	A+	A+	A+	A+
COP Outdoor air +7°C (EN16147)			3,34	3,34	3,36	3,36
Heating time (10-48°C) with outdoor air 7°C		hour-min	2h21	2h21	2h02	2h02
Heating time (37-48°C) with outdoor air 7°C		hour-min	0h47	0h47	0h40	0h40
Quantity of water delivered at 40°C with a flow rate of 10 l/min		l	275	275	275	275
ELECTRICAL CHARACTERISTICS						
Electrical power supply		V/ph/Hz	230/1/50	230/1/50	230/1/50	230/1/50
Maximum total input current	1	kW	2,20	2,60	3,30	3,60
Maximum total input current	2	A	12,00	14,00	16,00	17,00
COMPRESSOR						
Compressor		Type/brand	Twin Rotary/ Mitsubishi	Twin Rotary/ Mitsubishi	Twin Rotary/ Mitsubishi	Twin Rotary/ Mitsubishi
Adjustment		Type	DC Inverter	DC Inverter	DC Inverter	DC Inverter
Minimum partialisation (A7°C; W35°C)		%	55%	44%	40%	38%
Refrigerant		Type	R32	R32	R32	R32
GWP			675	675	675	675
Refrigerant charge		kg	1,50	1,50	1,65	1,65
CO ₂ equivalent		tons	1,01	1,01	1,11	1,11
Number of circuits		n.	1	1	1	1
Hermetically sealed control box (EU Reg. 573/2024)		yes/no	no	no	no	no

DESCRIPTION	NOTES	U.M.	DOMUS M			
Outdoor unit			HP EXTERNAL UNIT R32			
			004	006	008	010
Indoor unit			HP IDU DOMUS			
			L61			
FAN						
Fan		Type	Axial	Axial	Axial	Axial
Quantity		n.	1	1	1	1
Maximum air flow		m ³ /h	2770	2770	4030	4030
Useful head		Pa	-	-	-	-
AIR-SIDE HEAT EXCHANGER						
Air-side heat exchanger		Type	Copper pipes, fins in hydrophilic aluminium with anti-corrosion treatment			
HYDRONIC MODULE						
Circulation pump		Type/adjustment	Variable speed centrifuge			
Nominal flow		m ³ /h	0,73	1,07	1,43	1,72
Useful head at nominal flow		Kpa	76	78	56	44
Maximum circulation pump absorbed power		W	90	90	90	90
Minimum circulation pump absorbed power		W	5	5	5	5
Calibration pressure of the safety valve		bar	3,0	3,0	3,0	3
Expansion reservoir volume		l	8	8	8	8
SYSTEM SIDE EXCHANGER						
System side exchanger		Type	With plates	With plates	With plates	With plates
Water content		l	5	5	5	5
NOISE LEVEL DATA						
Outdoor unit sound power	3	dB(A)	56	58	59	60
Outdoor unit sound pressure at 1m	4	dB(A)	44	45	46	49
Indoor unit sound power	3	dB(A)	38	38	40	40
Indoor unit sound pressure at 1 m	4	dB(A)	22	24	22	22
WEIGHT						
Outdoor unit net weight		kg	58	58	75	75
Indoor unit net weight		kg	157	157	157	157

NOTE

The performance is in accordance with standards UNI EN 14511 and UNI EN 14825.

- (1) Power absorbed by the outdoor unit at limit operating conditions and nominal supply voltage (for total system absorption add the power of the indoor units, with various supplementary heating elements, indicated in the electrical wiring section).
- (2) Maximum operating current of the unit at nominal supply voltage.
- (3) Declared noise emission values in accordance with EN 12102-1.
- (4) Measured in a semi-anechoic chamber, at a distance of 1m from the front of the unit and at a height from the floor equal to (1+H)/2, where H is the height of the unit expressed in metres (in accordance with standard EN 12102-1).
- (*) The energy efficiency class range of this product category is between D and A+++
- (**) The energy efficiency class range of this product category is between F and A+

The data contained in the boxes marked in grey are to be used for telematic transmission to ENEA for the purposes of tax deductions.

The data contained in the boxes marked in grey are to be used for the registration of the control box in the F-GAS database.

HEAT PUMPS

Floor-standing split heat pump

DESCRIPTION	NOTES	U.M.	DOMUS M		
			HP EXTERNAL UNIT R32		
Outdoor unit			012	014	016
Indoor unit			HP IDU DOMUS		
			L61		
HEATING PERFORMANCE DATA					
Heating performance (A7°C; W35°C)					
Nominal capacity		kW	12,10	14,50	16,00
Absorbed power		kW	2,44	3,09	3,56
COP			4,95	4,70	4,50
SCOP			4,81	4,72	4,62
Seasonal energy efficiency		%	189	186	182
Energy class		D → A+++ (*)	A+++	A+++	A+++
Heating performance (A7°C; W45°C)					
Nominal capacity		kW	12,30	14,20	16,00
Absorbed power		kW	3,24	3,89	4,44
COP			3,80	3,65	3,60
Heating performance (A7°C; W55°C)					
Nominal capacity		kW	12,00	13,80	16,00
Absorbed power		kW	3,87	4,60	5,52
COP			3,10	3,00	2,90
SCOP			3,45	3,47	3,41
Seasonal energy efficiency		%	135	136	133
Energy class		D → A+++ (*)	A++	A++	A++
COOLING PERFORMANCE DATA					
Cooling performance (A35°C; W7°C)					
Nominal capacity		kW	11,60	12,70	14,00
Absorbed power		kW	4,22	4,98	5,71
EER			2,75	2,55	2,45
SEER			4,89	4,86	4,69
Seasonal energy efficiency		%	192	191	184
Cooling performance (A35°C; W18°C)					
Nominal capacity		kW	12,00	13,50	14,20
Absorbed power		kW	3,00	3,74	3,93
EER			4,00	3,61	3,61
DHW PERFORMANCE DATA					
Domestic hot water boiler volume		l	240	240	240
Boiler material			Stainless steel	Stainless steel	Stainless steel
Maximum domestic hot water pressure		bar	10,00	10,00	10,00
Domestic hot water seasonal energy efficiency - Temperate zone		%	123	123	123
Domestic hot water energy class		F → A+ (*)	A+	A+	A+
COP Outdoor air +7°C (EN16147)			3,00	3,00	3,00
Heating time (10-48°C) with outdoor air 7°C		hour-min	1h38	1h38	1h38
Heating time (37-48°C) with outdoor air 7°C		hour-min	0h36	0h36	0h36
Quantity of water delivered at 40°C with a flow rate of 10 l/min		l	280	280	280
ELECTRICAL CHARACTERISTICS					
Electrical power supply		V/ph/Hz	230/1/50	230/1/50	230/1/50
Maximum total input current	1	kW	5,40	5,70	6,10
Maximum total input current	2	A	25,00	26,00	27,00
COMPRESSOR					
Compressor		Type/brand	Twin Rotary/ Mitsubishi	Twin Rotary/ Mitsubishi	Twin Rotary/ Mitsubishi
Adjustment		Type	DC Inverter	DC Inverter	DC Inverter
Minimum partialisation (A7°C; W35°C)		%	46%	41%	40%
Refrigerant		Type	R32	R32	R32
GWP			675	675	675
Refrigerant charge		kg	1,84	1,84	1,84
CO ₂ equivalent		tons	1,24	1,24	1,24
Number of circuits		n.	1	1	1
Hermetically sealed control box (EU Reg. 573/2024)		yes/no	no	no	no

DESCRIPTION	NOTES	U.M.	DOMUS M		
Outdoor unit			HP EXTERNAL UNIT R32		
			012	014	016
Indoor unit			HP IDU DOMUS		
			L61		
FAN					
Fan		Type	Axial	Axial	Axial
Quantity		n.	1	1	1
Maximum air flow		m ³ /h	4060	4060	4650
Useful head		Pa	-	-	-
AIR-SIDE HEAT EXCHANGER					
Air-side heat exchanger		Type	Copper pipes, fins in hydrophilic aluminium with anti-corrosion treatment		
HYDRONIC MODULE					
Circulation pump		Type/adjustment	Variable speed centrifuge		
Nominal flow		m ³ /h	2,08	2,49 ^(***)	2,75 ^(***)
Useful head at nominal flow		Kpa	21	- ^(***)	- ^(***)
Maximum circulation pump absorbed power		W	90	90	90
Minimum circulation pump absorbed power		W	5	5	5
Calibration pressure of the safety valve		bar	3,0	3,0	3,0
Expansion reservoir volume		l	8	8	8
SYSTEM SIDE EXCHANGER					
System side exchanger		Type	With plates	With plates	With plates
Water content		l	5	5	5
NOISE LEVEL DATA					
Outdoor unit sound power	3	dB(A)	64	65	68
Outdoor unit sound pressure at 1m	4	dB(A)	50	51	54
Indoor unit sound power	3	dB(A)	42	44	44
Indoor unit sound pressure at 1 m	4	dB(A)	24	25	24
WEIGHT					
Outdoor unit net weight		kg	111	111	111
Indoor unit net weight		kg	159	159	159

NOTE

The performance is in accordance with standards UNI EN 14511 and UNI EN 14825.

- (1) Power absorbed by the outdoor unit at limit operating conditions and nominal supply voltage (for total system absorption add the power of the indoor units, with various supplementary heating elements, indicated in the electrical wiring section).
 - (2) Maximum operating current of the unit at nominal supply voltage.
 - (3) Declared noise emission values in accordance with EN 12102-1.
 - (4) Measured in a semi-anechoic chamber, at a distance of 1m from the front of the unit and at a height from the floor equal to (1+H)/2, where H is the height of the unit expressed in metres (in accordance with standard EN 12102-1).
- (*) The energy efficiency class range of this product category is between D and A+++
(**) The energy efficiency class range of this product category is between F and A+
(***) For 14kW and 16kW models, it is mandatory to install a technical water buffer as hydraulic separator immediately after the machine water outlet. For the temperature control on the secondary circuit, also add the temperature probe for the buffer which is available among the accessories. The unit manages the secondary circulator as standard, which must be installed for the declared performance of the system.

The data contained in the boxes marked in grey are to be used for telematic transmission to ENEA for the purposes of tax deductions.

The data contained in the boxes marked in grey are to be used for the registration of the control box in the F-GAS database.

HEAT PUMPS

Floor-standing split heat pump

DESCRIPTION	NOTES	U.M.	DOMUS M		
			HP EXTERNAL UNIT R32		
Outdoor unit			12T	14T	16T
Indoor unit			HP IDU DOMUS		
			L93		
HEATING PERFORMANCE DATA					
Heating performance (A7°C; W35°C)					
Nominal capacity		kW	12,10	14,50	16,00
Absorbed power		kW	2,44	3,09	3,56
COP			4,95	4,70	4,50
SCOP			4,81	4,72	4,62
Seasonal energy efficiency		%	189	186	182
Energy class		D → A+++ (*)	A+++	A+++	A+++
Heating performance (A7°C; W45°C)					
Nominal capacity		kW	12,30	14,20	16,00
Absorbed power		kW	3,24	3,89	4,44
COP			3,80	3,65	3,60
Heating performance (A7°C; W55°C)					
Nominal capacity		kW	12,00	13,80	16,00
Absorbed power		kW	3,87	4,60	5,52
COP			3,10	3,00	2,90
SCOP			3,45	3,47	3,41
Seasonal energy efficiency		%	135	136	133
Energy class		D → A+++ (*)	A++	A++	A++
COOLING PERFORMANCE DATA					
Cooling performance (A35°C; W7°C)					
Nominal capacity		kW	11,60	12,70	14,00
Absorbed power		kW	4,22	4,98	5,71
EER			2,75	2,55	2,45
SEER			4,89	4,86	4,69
Seasonal energy efficiency		%	192	191	184
Cooling performance (A35°C; W18°C)					
Nominal capacity		kW	12,00	13,50	14,20
Absorbed power		kW	3,00	3,74	3,93
EER			4,00	3,61	3,61
DHW PERFORMANCE DATA					
Domestic hot water boiler volume		l	240	240	240
Boiler material			Stainless steel	Stainless steel	Stainless steel
Maximum domestic hot water pressure		bar	10,00	10,00	10,00
Domestic hot water seasonal energy efficiency - Temperate zone		%	123	123	123
Domestic hot water energy class		F → A+ (*)	A+	A+	A+
COP Outdoor air +7°C (EN16147)			3,00	3,00	3,00
Heating time (10-48°C) with outdoor air 7°C		hour-min	1h38	1h38	1h38
Heating time (37-48°C) with outdoor air 7°C		hour-min	0h36	0h36	0h36
Quantity of water delivered at 40°C with a flow rate of 10 l/min		l	280	280	280
ELECTRICAL CHARACTERISTICS					
Electrical power supply		V/ph/Hz	400/3/50	400/3/50	400/3/50
Maximum total input current	1	kW	5,40	5,70	6,10
Maximum total input current	2	A	10,00	11,00	12,00
COMPRESSOR					
Compressor		Type/brand	Twin Rotary/ Mitsubishi	Twin Rotary/ Mitsubishi	Twin Rotary/ Mitsubishi
Adjustment		Type	DC Inverter	DC Inverter	DC Inverter
Minimum partialisation (A7°C; W35°C)		%	46%	41%	40%
Refrigerant		Type	R32	R32	R32
GWP			675	675	675
Refrigerant charge		kg	1,84	1,84	1,84
CO ₂ equivalent		tons	1,24	1,24	1,24
Number of circuits		n.	1	1	1
Hermetically sealed control box (EU Reg. 573/2024)		yes/no	no	no	no

DESCRIPTION	NOTES	U.M.	DOMUS M		
Outdoor unit			HP EXTERNAL UNIT R32		
			12T	14T	16T
Indoor unit			HP IDU DOMUS		
			L93		
FAN					
Fan		Type	Axial	Axial	Axial
Quantity		n.	1	1	1
Maximum air flow		m ³ /h	4060	4060	4650
Useful head		Pa	-	-	-
AIR-SIDE HEAT EXCHANGER					
Air-side heat exchanger		Type	Copper pipes, fins in hydrophilic aluminium with anti-corrosion treatment		
HYDRONIC MODULE					
Circulation pump		Type/adjustment	Variable speed centrifuge		
Nominal flow		m ³ /h	2,08	2,49 ^(**)	2,49
Useful head at nominal flow		Kpa	21	- ^(***)	- ^(***)
Maximum circulation pump absorbed power		W	90	90	90
Minimum circulation pump absorbed power		W	5	5	5
Calibration pressure of the safety valve		bar	3,0	3,0	3,0
Expansion reservoir volume		l	8	8	8
SYSTEM SIDE EXCHANGER					
System side exchanger		Type	With plates	With plates	With plates
Water content		l	5	5	5
NOISE LEVEL DATA					
Outdoor unit sound power	3	dB(A)	64	65	68
Outdoor unit sound pressure at 1m	4	dB(A)	50	51	55
Indoor unit sound power	3	dB(A)	42	44	44
Indoor unit sound pressure at 1 m	4	dB(A)	24	25	24
WEIGHT					
Outdoor unit net weight		kg	126	126	126
Indoor unit net weight		kg	159	159	159

NOTE

The performance is in accordance with standards UNI EN 14511 and UNI EN 14825.

- (1) Power absorbed by the outdoor unit at limit operating conditions and nominal supply voltage (for total system absorption add the power of the indoor units, with various supplementary heating elements, indicated in the electrical wiring section).
 - (2) Maximum operating current of the unit at nominal supply voltage.
 - (3) Declared noise emission values in accordance with EN 12102-1.
 - (4) Measured in a semi-anechoic chamber, at a distance of 1m from the front of the unit and at a height from the floor equal to (1+H)/2, where H is the height of the unit expressed in metres (in accordance with standard EN 12102-1).
- (*) The energy efficiency class range of this product category is between D and A+++
(**) The energy efficiency class range of this product category is between F and A+
(***) For 14kW and 16kW models, it is mandatory to install a technical water buffer as hydraulic separator immediately after the machine water outlet. For the temperature control on the secondary circuit, also add the temperature probe for the buffer which is available among the accessories. The unit manages the secondary circulator as standard, which must be installed for the declared performance of the system.

The data contained in the boxes marked in grey are to be used for telematic transmission to ENEA for the purposes of tax deductions.

The data contained in the boxes marked in grey are to be used for the registration of the control box in the F-GAS database.

HEAT PUMPS

Floor-standing split heat pump

ERP TECHNICAL DATA

DESCRIPTION	U.M.	DOMUS M			
Outdoor unit		HP EXTERNAL UNIT R32			
		004	006	008	010
Indoor unit		HP IDU DOMUS			
		M61			
AMBIENT HEATING					
Temperate zone - Low temperature (30/35°C) EU Reg. 811/2013					
Seasonal energy efficiency	%	191	195	205	205
SCOP		4,85	4,95	5,21	5,19
Prated	kW	5,52	6,82	8,12	9,17
Yearly energy consumption	kWh/year	2351	2845	3218	3644
Energy class		A+++	A+++	A+++	A+++
Outdoor unit sound power	dB(A)	56	58	59	60
Indoor unit sound power	dB(A)	38	38	40	40
Temperate zone - Medium temperature (47/55°C) EU Reg. 811/2013					
Seasonal energy efficiency	%	130	138	132	137
SCOP		3,31	3,52	3,36	3,49
Prated	kW	4,40	5,70	6,60	7,67
Yearly energy consumption	kWh/year	2744	3345	4056	5540
Energy class	D → A+++	A++	A++	A++	A++
DOMESTIC HOT WATER					
Load profile		L	L	L	L
DHW energy efficiency class	F → A+	A+	A+	A+	A+
DHW annual energy consumption - Temperate zone	kWh/year	801	801	820	820
DHW annual energy consumption - Cold zone	kWh/year	649	649	675	675
DHW annual energy consumption - Hot zone	kWh/year	998	998	950	950
DHW seasonal energy efficiency - Temperate zone	%	127	127	125	125
DHW seasonal energy efficiency - Cold zone	%	157	157	151	151
DHW seasonal energy efficiency - Hot zone	%	102	102	107	107
Outdoor unit sound power	dB(A)	56	58	59	60
Indoor unit sound power	dB(A)	38	38	40	40

NOTE

The performance is in accordance with standard UNI EN 14825.

DESCRIPTION	U.M.	DOMUS M			
Outdoor unit		HP EXTERNAL UNIT R32			
		004	006	008	010
Indoor unit		HP IDU DOMUS			
		L61			
AMBIENT HEATING					
Temperate zone – Low temperature (30/35°C) EU Reg. 811/2013					
Seasonal energy efficiency	%	191	195	205	205
SCOP		4,85	4,95	5,21	5,19
Prated	kW	5,52	6,82	8,12	9,17
Yearly energy consumption	kWh/year	2351	2845	3218	3644
Energy class		A+++	A+++	A+++	A+++
Outdoor unit sound power	dB(A)	56	58	59	60
Indoor unit sound power	dB(A)	38	38	40	40
Temperate zone – Medium temperature (47/55°C) EU Reg. 811/2013					
Seasonal energy efficiency	%	130	138	132	137
SCOP		3,31	3,52	3,36	3,49
Prated	kW	4,40	5,70	6,60	7,67
Yearly energy consumption	kWh/year	2744	3345	4056	5540
Energy class	D → A+++	A++	A++	A++	A++
DOMESTIC HOT WATER					
Load profile		XL	XL	XL	XL
DHW energy efficiency class	F → A+	A+	A+	A+	A+
DHW annual energy consumption – Temperate zone	kWh/year	1229	1229	1218	1218
DHW annual energy consumption – Cold zone	kWh/year	963	963	977	977
DHW annual energy consumption – Hot zone	kWh/year	1561	1561	1508	1508
DHW seasonal energy efficiency – Temperate zone	%	136	136	137	137
DHW seasonal energy efficiency – Cold zone	%	174	174	171	171
DHW seasonal energy efficiency – Hot zone	%	107	107	111	111
Outdoor unit sound power	dB(A)	56	58	59	60
Indoor unit sound power	dB(A)	38	38	40	40

NOTE

The performance is in accordance with standard UNI EN 14825.

HEAT PUMPS

Floor-standing split heat pump

DESCRIPTION	U.M.	DOMUS M		
Outdoor unit		HP EXTERNAL UNIT R32		
		012	014	016
Indoor unit		HP IDU DOMUS		
		L61		
AMBIENT HEATING				
Temperate zone - Low temperature (30/35°C) EU Reg. 811/2013				
Seasonal energy efficiency	%	189	186	182
SCOP		4,81	4,72	4,62
Prated	kW	12,00	13,73	15,21
Yearly energy consumption	kWh/year	5153	6012	6804
Energy class		A+++	A+++	A+++
Outdoor unit sound power	dB(A)	64	65	68
Indoor unit sound power	dB(A)	42	44	44
Temperate zone - Medium temperature (47/55°C) EU Reg. 811/2013				
Seasonal energy efficiency	%	135	136	133
SCOP		3,45	3,47	3,41
Prated	kW	11,58	12,08	13,02
Yearly energy consumption	kWh/year	6927	7202	7895
Energy class	D → A+++	A++	A++	A++
DOMESTIC HOT WATER				
Load profile		XL	XL	XL
DHW energy efficiency class	F → A+	A+	A+	A+
DHW annual energy consumption - Temperate zone	kWh/year	1360	1360	1360
DHW annual energy consumption - Cold zone	kWh/year	1088	1088	1088
DHW annual energy consumption - Hot zone	kWh/year	1822	1822	1822
DHW seasonal energy efficiency - Temperate zone	%	123	123	123
DHW seasonal energy efficiency - Cold zone	%	153	153	153
DHW seasonal energy efficiency - Hot zone	%	92	92	92
Outdoor unit sound power	dB(A)	64	65	68
Indoor unit sound power	dB(A)	42	44	44

NOTE

The performance is in accordance with standard UNI EN 14825.

DESCRIPTION	U.M.	DOMUS M		
Outdoor unit		HP EXTERNAL UNIT R32		
		12T	14T	16T
Indoor unit		HP IDU DOMUS		
		L93		
AMBIENT HEATING				
Temperate zone – Low temperature (30/35°C) EU Reg. 811/2013				
Seasonal energy efficiency	%	189	186	182
SCOP		4,81	4,72	4,62
Prated	kW	12,00	13,73	15,21
Yearly energy consumption	kWh/year	5153	6013	6805
Energy class		A+++	A+++	A+++
Outdoor unit sound power	dB(A)	64	65	68
Indoor unit sound power	dB(A)	42	44	44
Temperate zone – Medium temperature (47/55°C) EU Reg. 811/2013				
Seasonal energy efficiency	%	135	136	133
SCOP		3,45	3,47	3,41
Prated	kW	11,58	12,08	13,02
Yearly energy consumption	kWh/year	6928	7203	7896
Energy class	D → A+++	A++	A++	A++
DOMESTIC HOT WATER				
Load profile		XL	XL	XL
DHW energy efficiency class	F → A+	A+	A+	A+
DHW annual energy consumption – Temperate zone	kWh/year	1360	1360	1360
DHW annual energy consumption – Cold zone	kWh/year	1088	1088	1088
DHW annual energy consumption – Hot zone	kWh/year	1822	1822	1822
DHW seasonal energy efficiency – Temperate zone	%	123	123	123
DHW seasonal energy efficiency – Cold zone	%	153	153	153
DHW seasonal energy efficiency – Hot zone	%	92	92	92
Outdoor unit sound power	dB(A)	64	65	68
Indoor unit sound power	dB(A)	42	44	44

NOTE

The performance is in accordance with standard UNI EN 14825.

HEAT PUMPS

Floor-standing split heat pump

PERFORMANCE DATA

UNI 11300 PART 3 AND 4: PERFORMANCE ACCORDING TO STANDARDS UNI EN 14511 AND UNI EN 14825

SINGLE-PHASE PERFORMANCE DATA

Outdoor unit:

HP EXTERNAL UNIT R32-004

Indoor unit:

HP IDU DOMUS M61 / 4-10

HP IDU DOMUS L61 / 4-10

HEATING						
Performance at full load						
Delivery temperature	35°C		45°C		55°C	
External temperature	Nominal capacity (kW)	COP	Nominal capacity (kW)	COP	Nominal capacity (kW)	COP
-7	4,70	3,10	4,30	2,35	4,00	1,95
2	4,40	4,00	5,10	3,00	5,10	2,45
7	4,25	5,20	4,35	3,80	4,40	2,95
12	5,26	5,61	5,60	4,22	4,98	3,38
15	5,14	5,84	5,67	4,37	4,96	3,53
20	5,09	6,21	5,63	4,88	4,89	3,84
35	5,54	7,89	5,70	6,47	5,14	4,92
Performance at partial load						
Tbival (-7°C)	A	B	C	D		
External temperature (°C)	-7	2	7	12		
PLR - Climatic load factor	0,88	0,54	0,35	0,15		
DC - Power at full load	4,70	4,40	4,25	5,26		
COP at full load	3,10	4,00	5,20	5,61		
COP at partial load	3,12	4,12	4,50	4,04		
CR - Load factor	1,00	0,68	0,45	0,16		
f COP - Correction factor	1,00	1,03	0,86	0,72		

COOLING				
EER	Load factor	External temperature (°C)	EER	Nominal capacity (kW)
EER1	100%	35	3,45	4,70
EER2	75%	30	4,76	3,53
EER3	50%	25	5,72	2,35
EER4	25%	20	5,72	1,18

HEATING

The performance is in accordance with standards UNI EN 14511 and UNI EN 14825.
The performance at partial load are referred to a water flow temperature of 35°C.

COOLING

Performance according to standard UNI EN 14825.

Outdoor unit:**HP EXTERNAL UNIT R32-006****Indoor unit:****HP IDU DOMUS M61 / 4-10****HP IDU DOMUS L61 / 4-10**

HEATING						
Performance at full load						
Delivery temperature	35°C		45°C		55°C	
External temperature	Nominal capacity (kW)	COP	Nominal capacity (kW)	COP	Nominal capacity (kW)	COP
-7	6,00	3,00	5,40	2,40	5,15	2,00
2	5,50	3,90	5,80	3,00	5,65	2,45
7	6,20	5,00	6,35	3,75	6,00	3,00
12	6,51	5,38	6,83	4,09	6,12	3,27
15	6,48	5,57	6,98	4,32	6,15	3,42
20	6,27	6,28	6,82	4,62	6,03	3,76
35	6,46	8,87	6,55	5,79	6,02	4,75
Performance at partial load						
Tbival (-7°C)	A	B	C	D		
External temperature (°C)	-7	2	7	12		
PLR - Climatic load factor	0,88	0,54	0,35	0,15		
DC - Power at full load	6,00	5,50	6,20	6,51		
COP at full load	3,00	3,90	5,00	5,38		
COP at partial load	3,03	4,18	4,86	4,09		
CR - Load factor	1,00	0,67	0,38	0,16		
f COP - Correction factor	1,00	1,07	0,97	0,76		

COOLING				
EER	Load factor	External temperature (°C)	EER	Nominal capacity (kW)
EER1	100%	35	3,00	7,00
EER2	75%	30	4,00	5,25
EER3	50%	25	6,45	3,50
EER4	25%	20	7,73	1,75

HEATING

The performance is in accordance with standards UNI EN 14511 and UNI EN 14825.
The performance at partial load are referred to a water flow temperature of 35°C.

COOLING

Performance according to standard UNI EN 14825.

HEAT PUMPS

Floor-standing split heat pump

Outdoor unit:

HP EXTERNAL UNIT R32-008

Indoor unit:

HP IDU DOMUS M61 / 4-10

HP IDU DOMUS L61 / 4-10

HEATING						
Performance at full load						
Delivery temperature	35°C		45°C		55°C	
External temperature	Nominal capacity (kW)	COP	Nominal capacity (kW)	COP	Nominal capacity (kW)	COP
-7	7,00	3,20	6,60	2,55	6,15	2,05
2	7,10	4,10	7,40	3,25	7,10	2,60
7	8,30	5,20	8,20	3,95	7,50	3,18
12	8,03	5,99	8,06	4,26	7,26	3,54
15	8,11	6,37	8,15	4,55	7,33	3,68
20	8,37	7,53	8,36	5,25	7,47	4,14
35	7,89	8,74	8,83	6,77	7,48	5,03
Performance at partial load						
Tbival (-7°C)	A	B	C	D		
External temperature (°C)	-7	2	7	12		
PLR - Climatic load factor	0,88	0,54	0,35	0,15		
DC - Power at full load	7,00	7,10	8,30	8,03		
COP at full load	3,20	4,10	5,20	5,99		
COP at partial load	3,28	4,39	5,00	4,37		
CR - Load factor	1,00	0,62	0,34	0,15		
f COP - Correction factor	1,00	1,07	0,96	0,73		

COOLING				
EER	Load factor	External temperature (°C)	EER	Nominal capacity (kW)
EER1	100%	35	3,38	7,40
EER2	75%	30	4,71	5,55
EER3	50%	25	6,65	3,70
EER4	25%	20	8,55	1,85

HEATING

The performance is in accordance with standards UNI EN 14511 and UNI EN 14825.
The performance at partial load are referred to a water flow temperature of 35°C.

COOLING

Performance according to standard UNI EN 14825.

Outdoor unit:**HP EXTERNAL UNIT R32-010****Indoor unit:****HP IDU DOMUS M61 / 4-10****HP IDU DOMUS L61 / 4-10**

HEATING						
Performance at full load						
Delivery temperature	35°C		45°C		55°C	
External temperature	Nominal capacity (kW)	COP	Nominal capacity (kW)	COP	Nominal capacity (kW)	COP
-7	8,00	3,05	7,35	2,55	6,85	2,00
2	8,20	4,00	7,85	3,20	8,10	2,56
7	10,00	5,00	10,00	3,80	9,50	3,10
12	9,03	5,77	9,11	4,06	8,50	3,41
15	9,13	6,22	9,22	4,38	8,60	3,67
20	9,58	7,14	9,46	5,08	8,73	4,05
35	8,59	9,01	9,81	6,84	8,63	5,29
Performance at partial load						
Tbival (-7°C)	A	B	C	D		
External temperature (°C)	-7	2	7	12		
PLR - Climatic load factor	0,88	0,54	0,35	0,15		
DC - Power at full load	8,00	8,20	10,00	9,03		
COP at full load	3,05	4,00	5,00	5,77		
COP at partial load	3,16	4,32	5,19	4,55		
CR - Load factor	1,00	0,60	0,32	0,15		
f COP - Correction factor	1,00	1,08	1,04	0,79		

COOLING				
EER	Load factor	External temperature (°C)	EER	Nominal capacity (kW)
EER1	100%	35	3,30	8,20
EER2	75%	30	4,47	6,15
EER3	50%	25	7,02	4,10
EER4	25%	20	9,54	2,05

HEATING

The performance is in accordance with standards UNI EN 14511 and UNI EN 14825.
The performance at partial load are referred to a water flow temperature of 35°C.

COOLING

Performance according to standard UNI EN 14825.

HEAT PUMPS

Floor-standing split heat pump

Outdoor unit:

HP EXTERNAL UNIT R32-12

Indoor unit:

HP IDU DOMUS L61 / 12-16

HEATING						
Performance at full load						
Delivery temperature	35°C		45°C		55°C	
External temperature	Nominal capacity (kW)	COP	Nominal capacity (kW)	COP	Nominal capacity (kW)	COP
-7	10,00	3,00	10,20	2,40	9,80	2,05
2	9,20	3,90	10,60	3,00	11,30	2,50
7	12,10	4,95	12,30	3,80	12,00	3,10
12	10,98	5,75	11,10	4,26	9,53	3,17
15	11,00	5,97	11,20	4,52	9,12	3,20
20	10,77	7,18	11,19	5,16	9,00	3,61
35	11,55	8,78	11,45	6,17	10,00	4,86
Performance at partial load						
Tbival (-7°C)	A	B	C	D		
External temperature (°C)	-7	2	7	12		
PLR - Climatic load factor	0,88	0,54	0,35	0,15		
DC - Power at full load	10,00	9,20	12,10	10,98		
COP at full load	3,00	3,90	4,95	5,75		
COP at partial load	2,82	4,01	4,85	4,14		
CR - Load factor	1,00	0,70	0,35	0,16		
f COP - Correction factor	1,00	1,03	0,98	0,72		

COOLING				
EER	Load factor	External temperature (°C)	EER	Nominal capacity (kW)
EER1	100%	35	2,75	11,60
EER2	75%	30	3,93	8,70
EER3	50%	25	5,73	5,80
EER4	25%	20	6,75	2,90

HEATING

The performance is in accordance with standards UNI EN 14511 and UNI EN 14825.
The performance at partial load are referred to a water flow temperature of 35°C.

COOLING

Performance according to standard UNI EN 14825.

Outdoor unit:**HP EXTERNAL UNIT R32-14****Indoor unit:****HP IDU DOMUS L61 / 12-16**

HEATING						
Performance at full load						
Delivery temperature	35°C		45°C		55°C	
External temperature	Nominal capacity (kW)	COP	Nominal capacity (kW)	COP	Nominal capacity (kW)	COP
-7	12,00	2,85	11,70	2,35	11,00	2,05
2	11,00	3,60	11,50	2,85	12,40	2,45
7	14,50	4,70	14,20	3,65	13,80	3,00
12	11,50	5,46	11,69	4,12	10,28	3,32
15	11,62	5,67	11,89	4,25	9,84	3,41
20	11,09	6,27	11,47	4,87	9,53	3,74
35	11,77	8,63	11,99	6,10	10,09	4,93
Performance at partial load						
Tbival (-7°C)	A	B	C	D		
External temperature (°C)	-7	2	7	12		
PLR - Climatic load factor	0,88	0,54	0,35	0,15		
DC - Power at full load	12,00	11,00	14,50	11,50		
COP at full load	2,85	3,60	4,70	5,46		
COP at partial load	2,73	3,90	4,90	4,26		
CR - Load factor	1,00	0,67	0,33	0,18		
f COP - Correction factor	1,00	1,08	1,04	0,78		

COOLING				
EER	Load factor	External temperature (°C)	EER	Nominal capacity (kW)
EER1	100%	35	2,55	12,70
EER2	75%	30	3,85	9,53
EER3	50%	25	5,80	6,35
EER4	25%	20	6,74	3,18

HEATING

The performance is in accordance with standards UNI EN 14511 and UNI EN 14825.
The performance at partial load are referred to a water flow temperature of 35°C.

COOLING

Performance according to standard UNI EN 14825.

HEAT PUMPS

Floor-standing split heat pump

Outdoor unit:

HP EXTERNAL UNIT R32-16

Indoor unit:

HP IDU DOMUS L61 / 12-16

HEATING						
Performance at full load						
Delivery temperature	35°C		45°C		55°C	
External temperature	Nominal capacity (kW)	COP	Nominal capacity (kW)	COP	Nominal capacity (kW)	COP
-7	13,10	2,70	12,80	2,25	12,50	2,00
2	13,00	3,45	12,70	2,85	13,30	2,40
7	16,00	4,50	16,00	3,60	16,00	2,90
12	14,03	5,58	13,76	4,22	12,69	3,44
15	14,48	5,97	14,21	4,46	13,22	3,61
20	12,95	6,88	12,22	4,71	11,19	3,68
35	12,80	9,06	12,48	6,02	10,38	4,57
Performance at partial load						
Tbival (-7°C)	A	B	C	D		
External temperature (°C)	-7	2	7	12		
PLR - Climatic load factor	0,88	0,54	0,35	0,15		
DC - Power at full load	13,10	13,00	16,00	14,03		
COP at full load	2,70	3,45	4,50	5,58		
COP at partial load	2,66	3,80	4,81	4,32		
CR - Load factor	1,00	0,63	0,33	0,16		
f COP - Correction factor	1,00	1,10	1,07	0,77		

COOLING				
EER	Load factor	External temperature (°C)	EER	Nominal capacity (kW)
EER1	100%	35	2,45	14,00
EER2	75%	30	3,63	10,50
EER3	50%	25	5,27	7,00
EER4	25%	20	7,29	3,50

HEATING

The performance is in accordance with standards UNI EN 14511 and UNI EN 14825.
The performance at partial load are referred to a water flow temperature of 35°C.

COOLING

Performance according to standard UNI EN 14825.

THREE-PHASE PERFORMANCE DATA

Outdoor unit:

HP EXTERNAL UNIT R32-12T

Indoor unit:

HP IDU DOMUS L93 / 12-16

HEATING						
Performance at full load						
Delivery temperature	35°C		45°C		55°C	
External temperature	Nominal capacity (kW)	COP	Nominal capacity (kW)	COP	Nominal capacity (kW)	COP
-7	7,58	3,17	7,47	2,64	7,36	2,20
2	9,82	4,02	9,56	3,28	9,30	2,76
7	12,10	4,95	12,30	3,80	12,00	3,10
12	12,02	5,44	11,80	4,17	11,58	3,53
15	12,50	5,34	12,27	4,22	12,04	3,58
20	12,16	5,36	12,06	4,36	11,97	3,69
35	11,02	7,99	11,34	4,73	11,67	4,07
Performance at partial load						
Tbival (-7°C)	A	B	C	D		
External temperature (°C)	-7	2	7	12		
PLR - Climatic load factor	0,88	0,54	0,35	0,15		
DC - Power at full load	7,58	9,82	12,10	12,02		
COP at full load	3,17	4,02	4,95	5,44		
COP at partial load	2,82	4,01	4,85	4,14		
CR - Load factor	1,00	0,70	0,35	0,16		
f COP - Correction factor	1,00	1,03	0,98	0,72		

COOLING				
EER	Load factor	External temperature (°C)	EER	Nominal capacity (kW)
EER1	100%	35	2,75	11,60
EER2	75%	30	3,27	7,01
EER3	50%	25	4,01	4,86
EER4	25%	20	3,83	2,73

HEATING

The performance is in accordance with standards UNI EN 14511 and UNI EN 14825.
The performance at partial load are referred to a water flow temperature of 35°C.

COOLING

Performance according to standard UNI EN 14825.

HEAT PUMPS

Floor-standing split heat pump

Outdoor unit:

HP EXTERNAL UNIT R32-14T

Indoor unit:

HP IDU DOMUS L93 / 12-16

HEATING						
Performance at full load						
Delivery temperature	35°C		45°C		55°C	
External temperature	Nominal capacity (kW)	COP	Nominal capacity (kW)	COP	Nominal capacity (kW)	COP
-7	12,00	2,85	11,70	2,35	11,00	2,05
2	11,00	3,60	11,50	2,85	12,40	2,45
7	14,50	4,70	14,20	3,65	13,80	3,00
12	11,50	5,46	11,69	4,12	10,28	3,32
15	11,62	5,67	11,89	4,25	9,84	3,41
20	11,09	6,27	11,47	4,87	9,53	3,74
35	11,77	8,63	11,99	6,10	10,09	4,93
Performance at partial load						
Tbival (-7°C)	A	B	C	D		
External temperature (°C)	-7	2	7	12		
PLR - Climatic load factor	0,88	0,54	0,35	0,15		
DC - Power at full load	12,00	11,00	14,50	11,50		
COP at full load	2,85	3,60	4,70	5,46		
COP at partial load	2,73	3,90	4,90	4,26		
CR - Load factor	1,00	0,67	0,33	0,18		
f COP - Correction factor	1,00	1,08	1,04	0,78		

COOLING				
EER	Load factor	External temperature (°C)	EER	Nominal capacity (kW)
EER1	100%	35	2,55	12,70
EER2	75%	30	3,85	9,53
EER3	50%	25	5,80	6,35
EER4	25%	20	6,74	3,18

HEATING

The performance is in accordance with standards UNI EN 14511 and UNI EN 14825.
The performance at partial load are referred to a water flow temperature of 35°C.

COOLING

Performance according to standard UNI EN 14825.

Outdoor unit:**HP EXTERNAL UNIT R32-16T****Indoor unit:****HP IDU DOMUS L93 / 12-16**

HEATING						
Performance at full load						
Delivery temperature	35°C		45°C		55°C	
External temperature	Nominal capacity (kW)	COP	Nominal capacity (kW)	COP	Nominal capacity (kW)	COP
-7	13,10	2,70	12,80	2,25	12,50	2,00
2	13,00	3,45	12,70	2,85	13,30	2,40
7	16,00	4,50	16,00	3,60	16,00	2,90
12	14,03	5,58	13,76	4,22	12,69	3,44
15	14,48	5,97	14,21	4,46	13,22	3,61
20	12,95	6,88	12,22	4,71	11,19	3,68
35	12,80	9,06	12,48	6,02	10,38	4,57
Performance at partial load						
Tbival (-7°C)	A	B	C	D		
External temperature (°C)	-7	2	7	12		
PLR - Climatic load factor	0,88	0,54	0,35	0,15		
DC - Power at full load	13,10	13,00	16,00	14,03		
COP at full load	2,70	3,45	4,50	5,58		
COP at partial load	2,66	3,80	4,81	4,32		
CR - Load factor	1,00	0,63	0,33	0,16		
f COP - Correction factor	1,00	1,10	1,07	0,77		

COOLING				
EER	Load factor	External temperature (°C)	EER	Nominal capacity (kW)
EER1	100%	35	2,45	14,00
EER2	75%	30	3,63	10,50
EER3	50%	25	5,27	7,00
EER4	25%	20	7,29	3,50

HEATING

The performance is in accordance with standards UNI EN 14511 and UNI EN 14825.
The performance at partial load are referred to a water flow temperature of 35°C.

COOLING

Performance according to standard UNI EN 14825.

HEAT PUMPS

Floor-standing split heat pump

OPERATING LIMITS

HEATING MODE

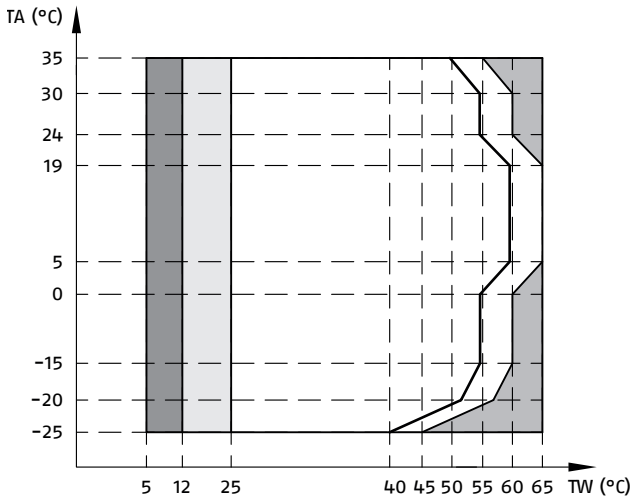

TA Outdoor air temperature
 TW Water delivery temperature.

- Operating range with heat pump, with possible limits and protection.
- The heat pump switches off and only the external heat source is active.
- If the external heat source setting is enabled, only the external heat source activates.
 If the external heat source setting is disabled, only the heat pump is active. Limitations and protection may arise while the heat pump is operating.

COOLING MODE

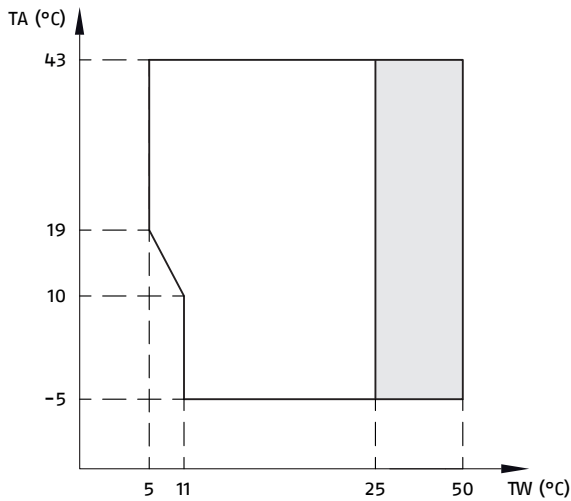

TA Outdoor air temperature
 TW Water delivery temperature.

- Operating range with heat pump, with possible limits and protection.

DHW MODE

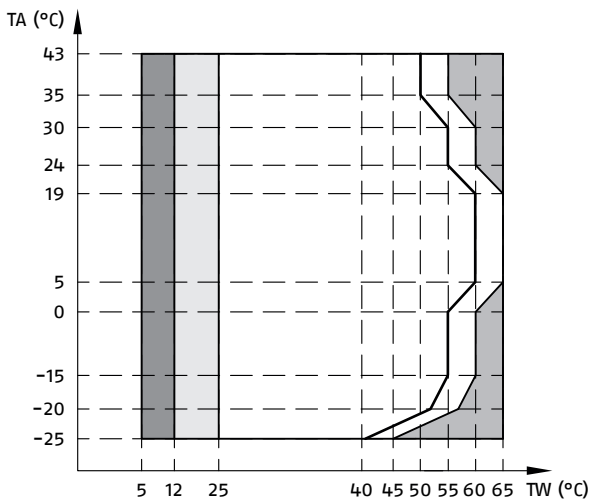

TA Outdoor air temperature
 TW Water delivery temperature.

- Operating range with heat pump, with possible limits and protection.
- The heat pump switches off and only the external heat source is active.
- If the external heat source setting is enabled, only the external heat source activates.
 If the external heat source setting is disabled, only the heat pump is active. Limitations and protection may arise while the heat pump is operating.

SOUND PRESSURE LEVELS

DESCRIPTION	U. M.	HP EXTERNAL UNIT R32									
OUTDOOR UNIT		004	006	008	010	012	014	016	12T	14T	16T
Sound pressure ⁽¹⁾	dB(A) ⁽²⁾	44	45	46	49	50	51	54	50	51	55

NOTE

(1) The sound pressure level is measured at a position 1 m in front of the unit and $(1+H)/2$ m (where H is the height of the unit) above the floor in a semi-anechoic chamber. During on-site operation, sound pressure levels may be higher due to ambient noise.

(2) dB is the maximum value tested under the following conditions:
Outdoor air temperature 7°C DB, 85% R.H.; EWT 30°C, LWT 35°C. Variable compressor frequency. Outdoor air temperature 35°C DB;
EWT 23°C, LWT 18°C. Variable compressor frequency.

OUTDOOR UNIT

We measure noise of the unit from 4 sides as below, with a rated frequency at the distance of 1m.

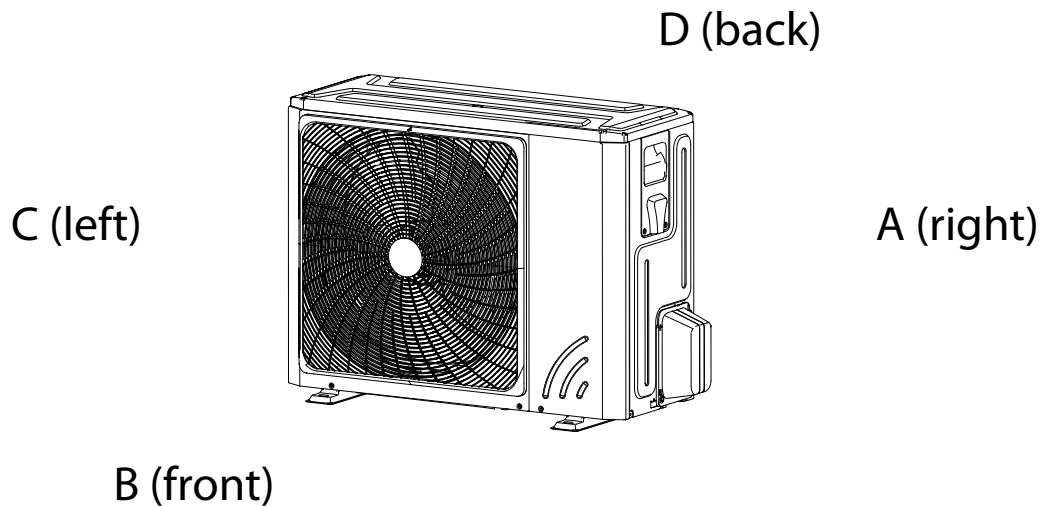

The conditions we've tested is illustrated as below:

- Heating A7W35: Evaporator air in 7°C, 85% R.H., Condenser water in/out 30/35°C
- Heating A7W45: Evaporator air in 7°C, 85% R.H., Condenser water in/out 40/45°C
- Cooling A35W18: Condenser air in 35°C. Evaporator water in/out 23/18°C
- Cooling A35W7: Condenser air in 35°C. Evaporator water in/out 12/7°C

HEAT PUMPS

Floor-standing split heat pump

SINGLE-PHASE

HP EXTERNAL UNIT R32 - 004

Heating A7W35

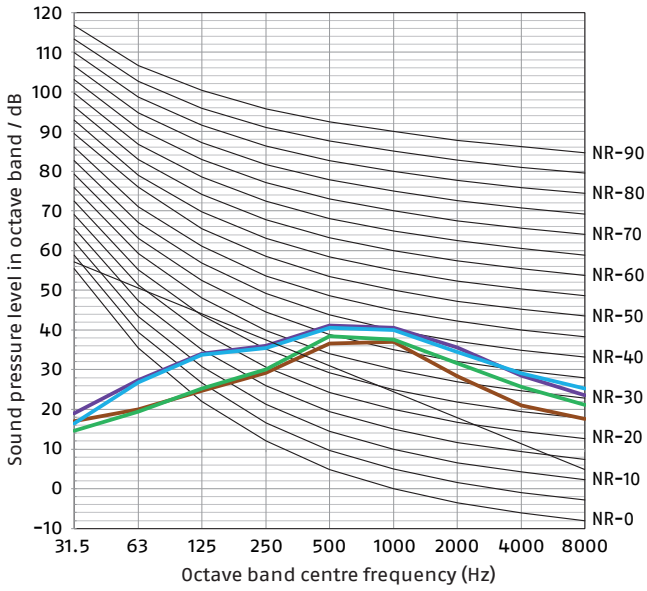

Heating A7W45

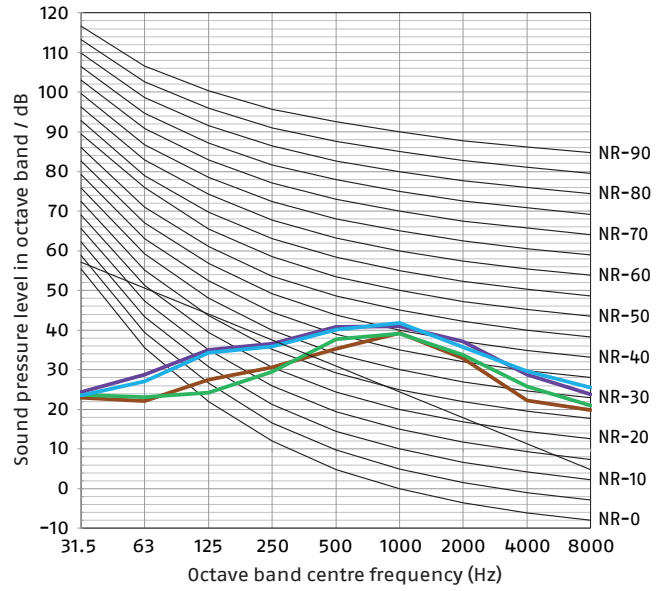

Cooling A35W18

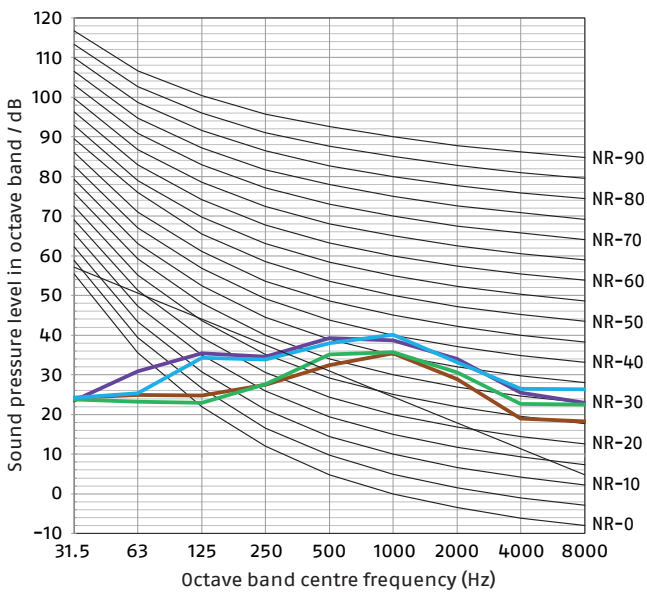

Cooling A35W7

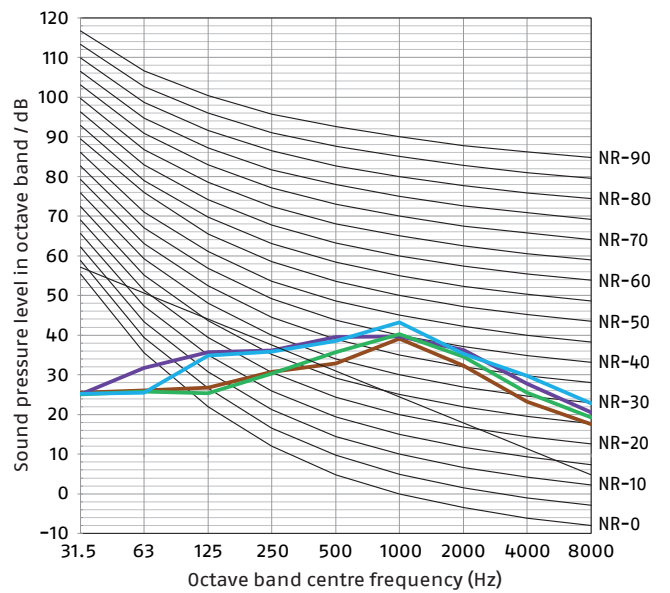

HP EXTERNAL UNIT R32 - 006

Heating A7W35

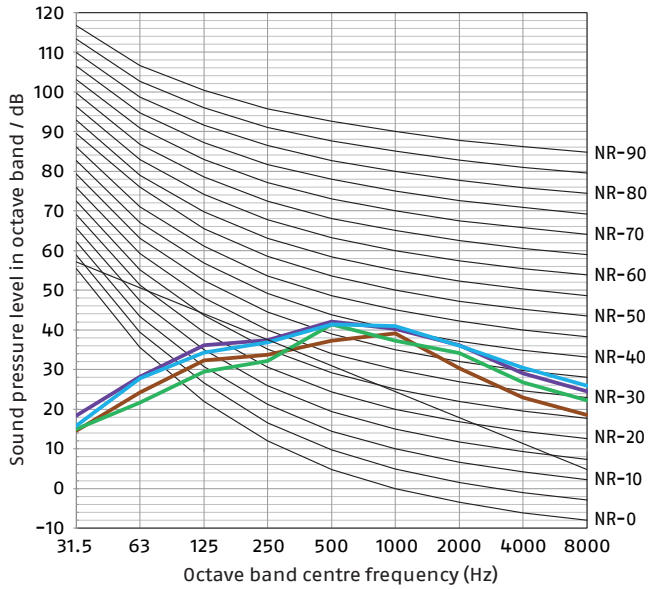

Heating A7W45

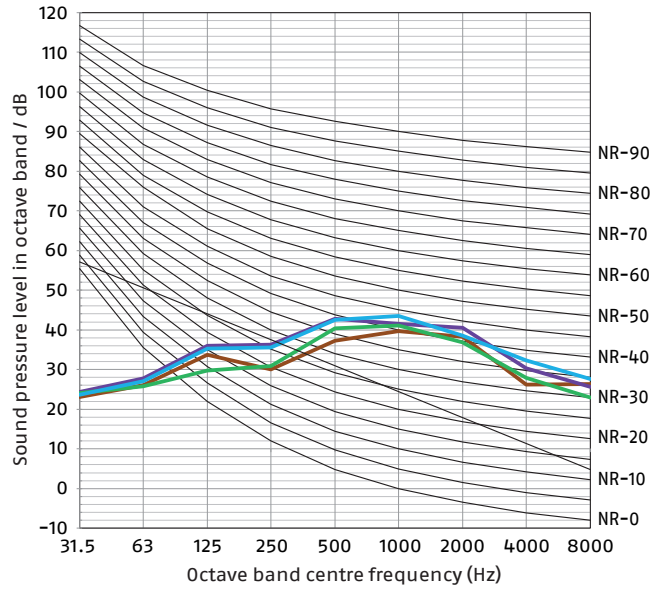

Cooling A35W18

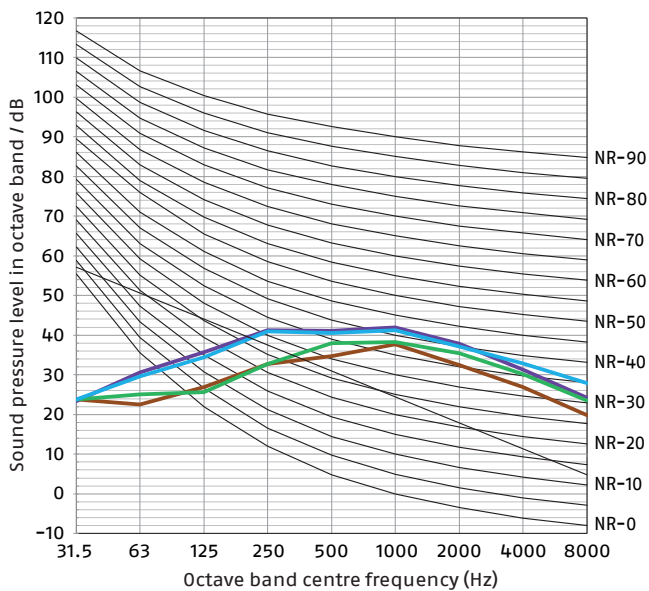

Cooling A35W7

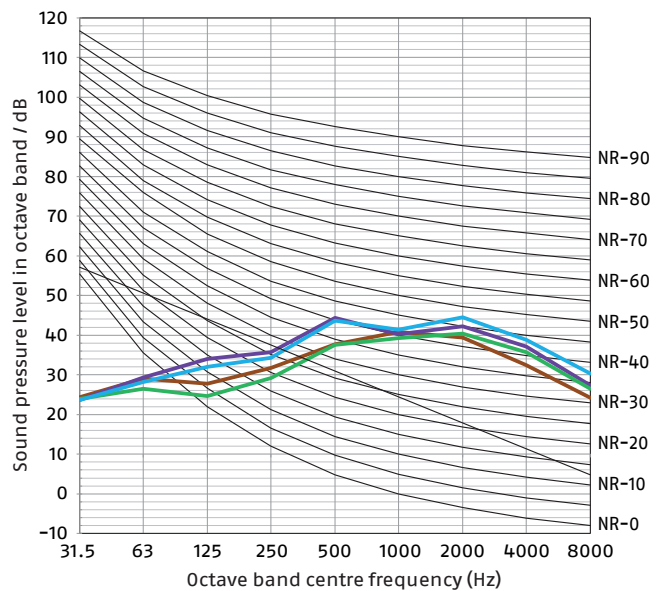

HEAT PUMPS

Floor-standing split heat pump

HP EXTERNAL UNIT R32 - 008

Heating A7W35

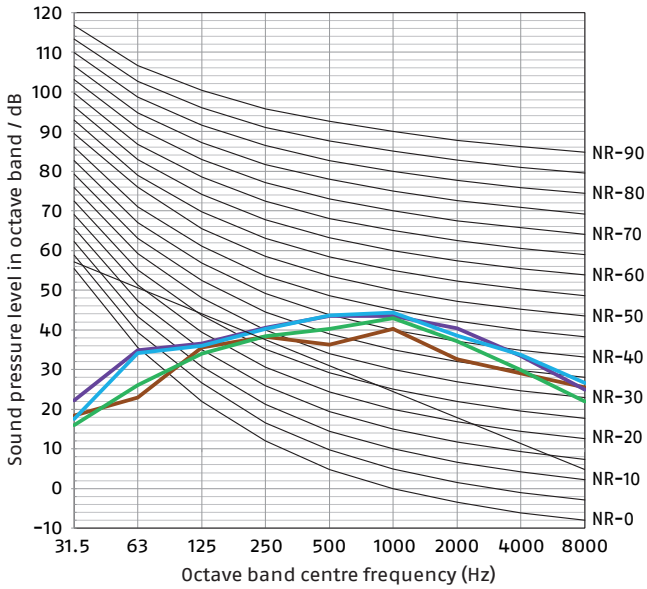

Heating A7W45

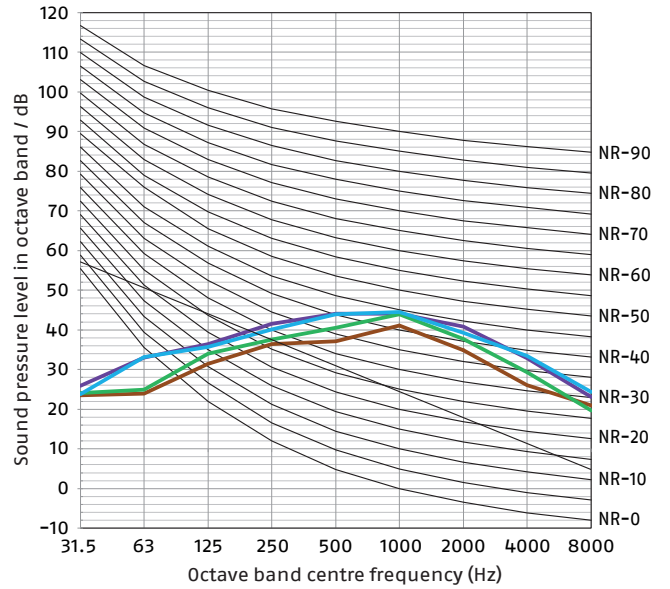

Cooling A35W18

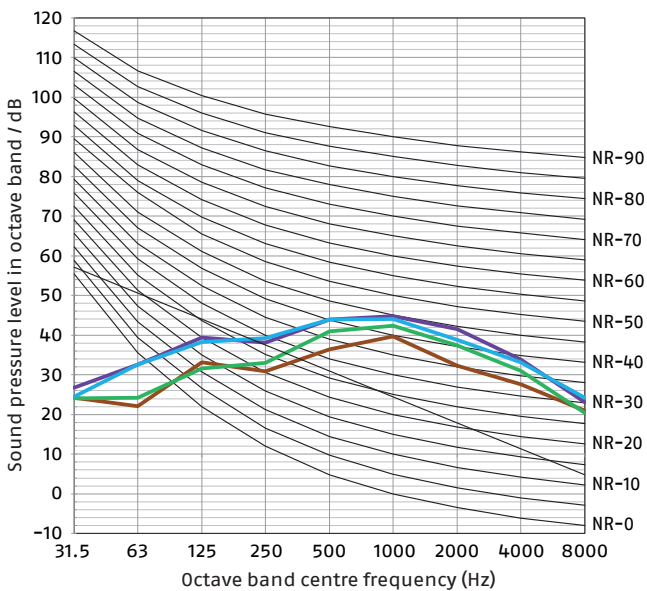

Cooling A35W7

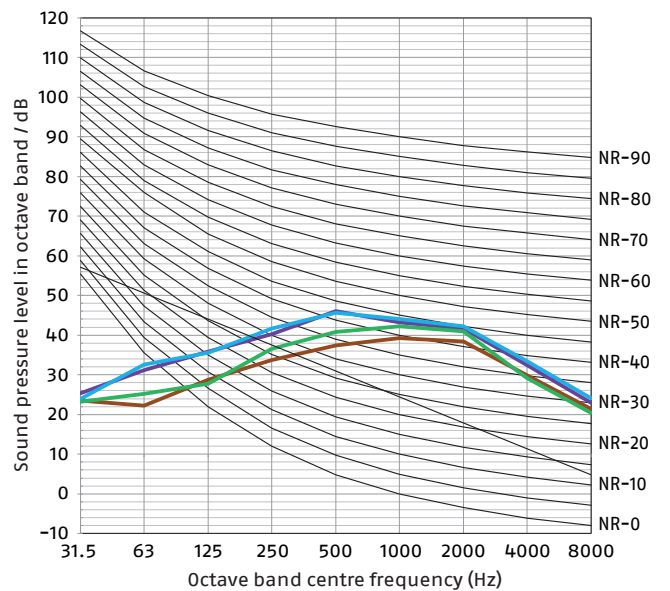

HP EXTERNAL UNIT R32 - 010

Heating A7W35

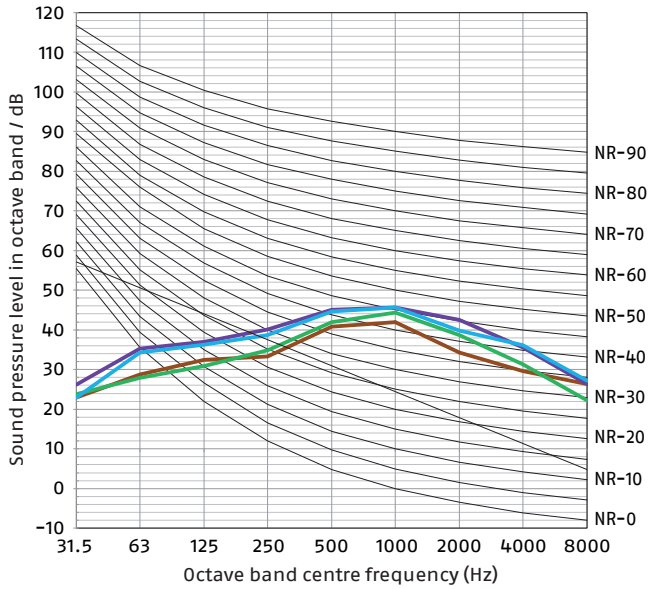

Heating A7W45

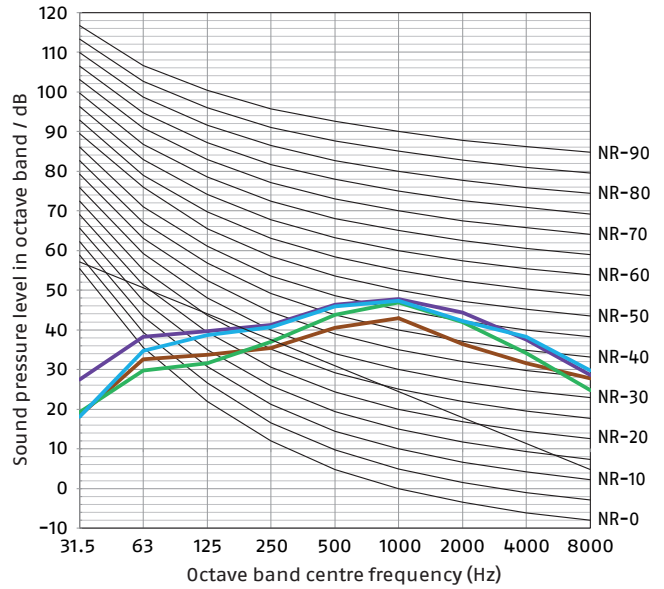

Cooling A35W18

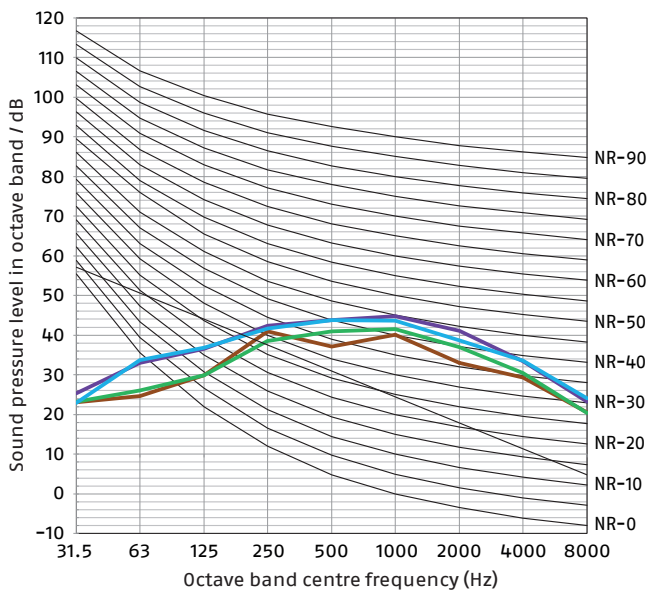

Cooling A35W7

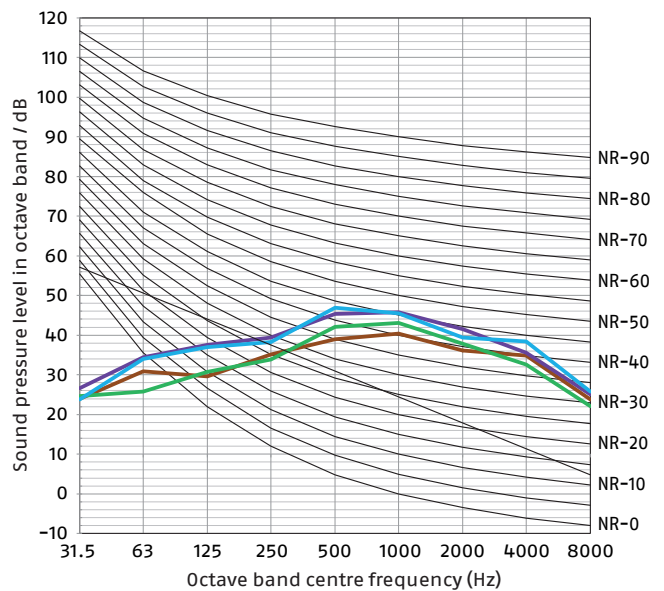

HEAT PUMPS

Floor-standing split heat pump

HP EXTERNAL UNIT R32 - 012

Heating A7W35

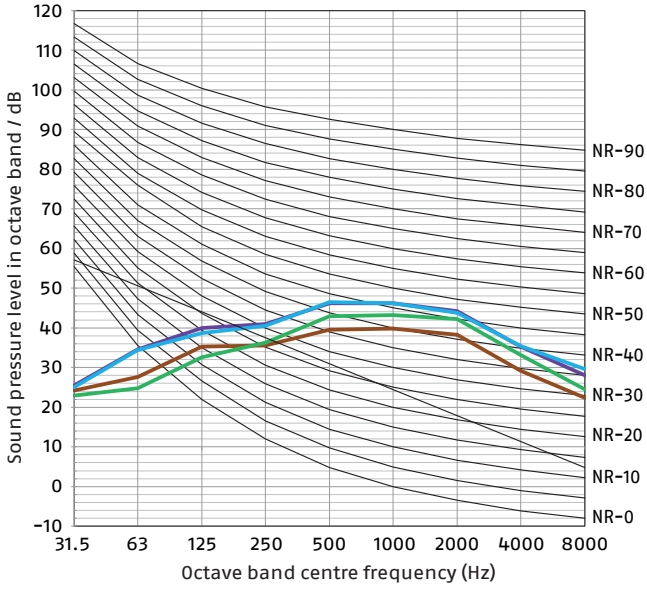

Heating A7W45

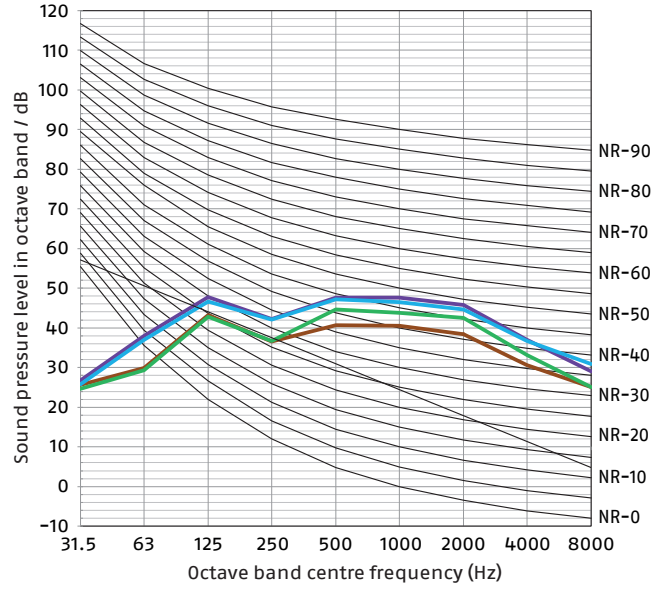

Cooling A35W18

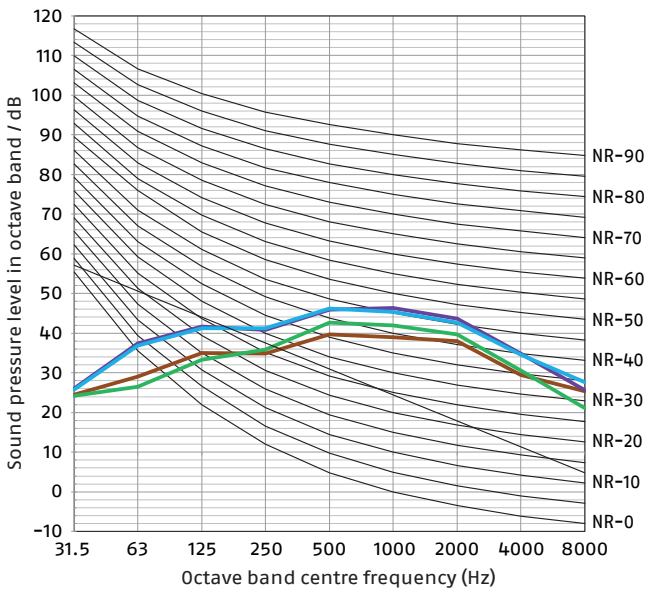

Cooling A35W7

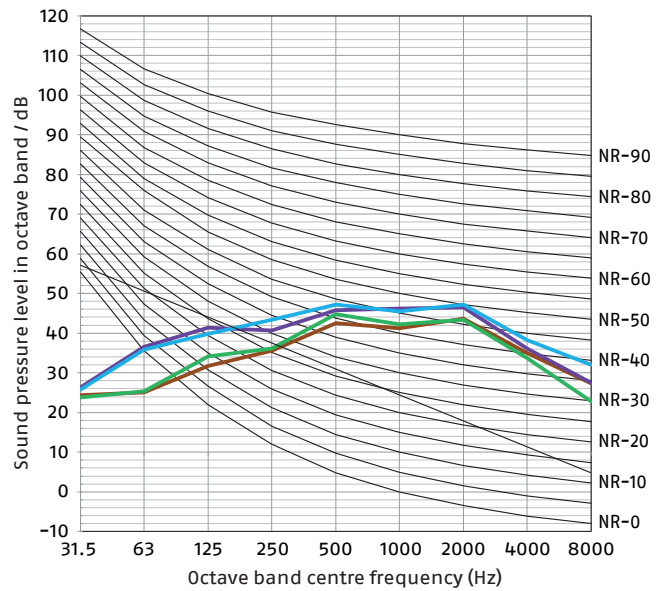

HP EXTERNAL UNIT R32 - 014

Heating A7W35

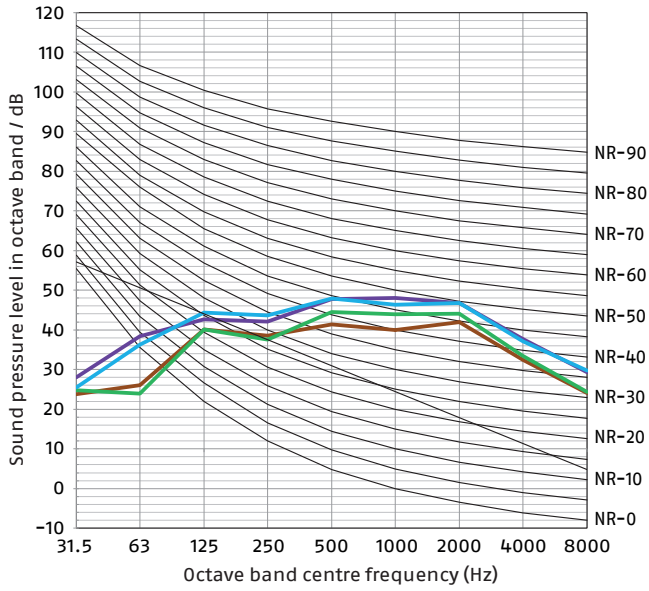

Heating A7W45

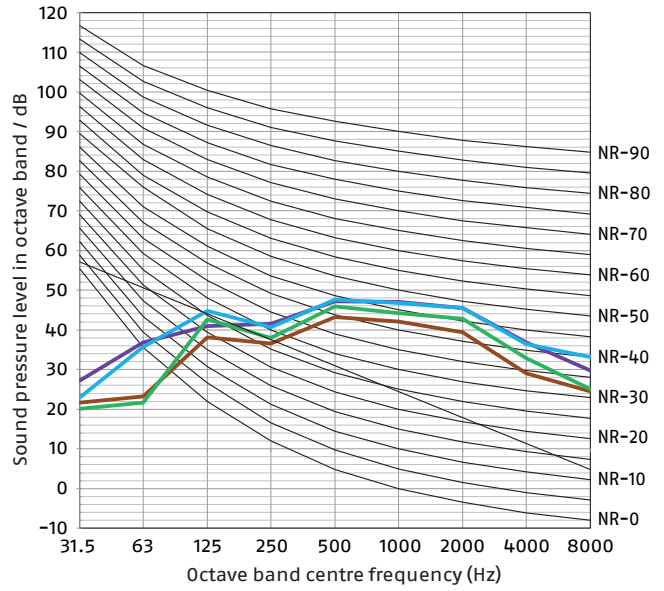

Cooling A35W18

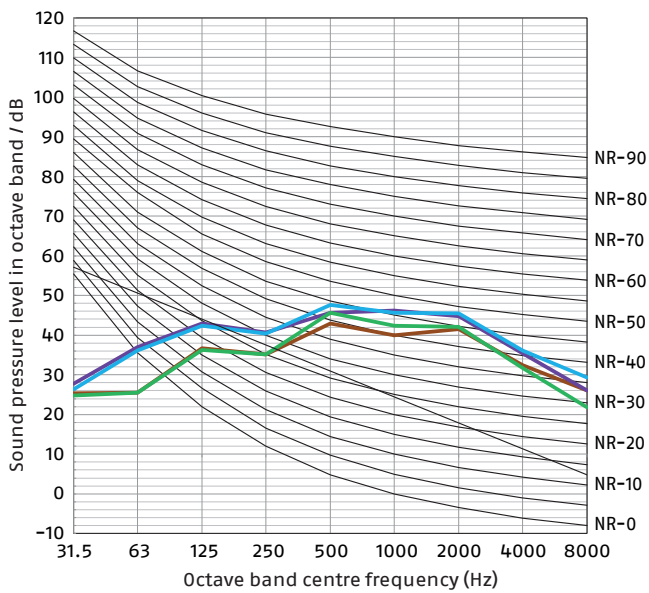

Cooling A35W7

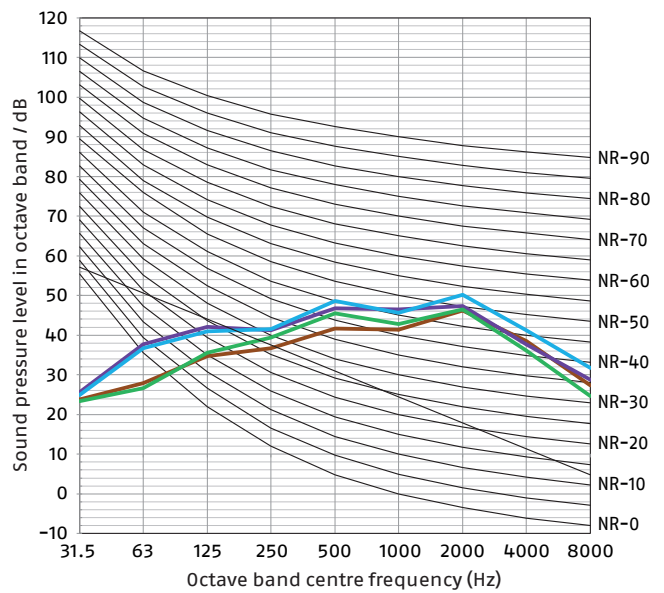

HEAT PUMPS

Floor-standing split heat pump

HP EXTERNAL UNIT R32 - 016

Heating A7W35

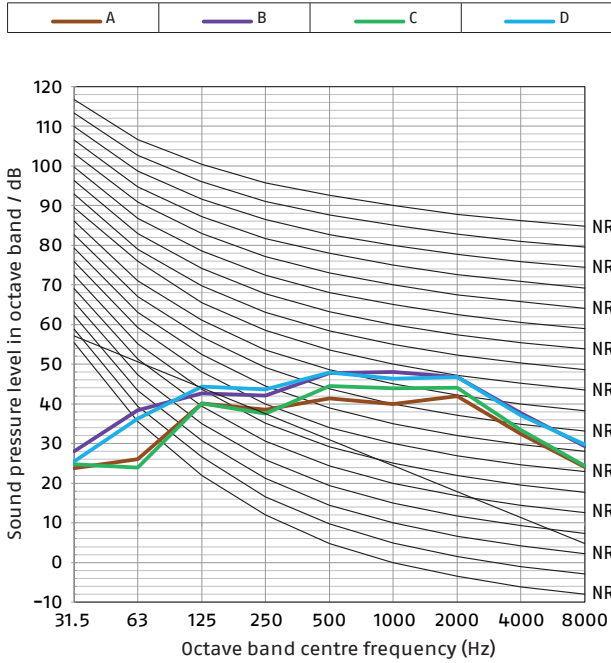

Heating A7W45

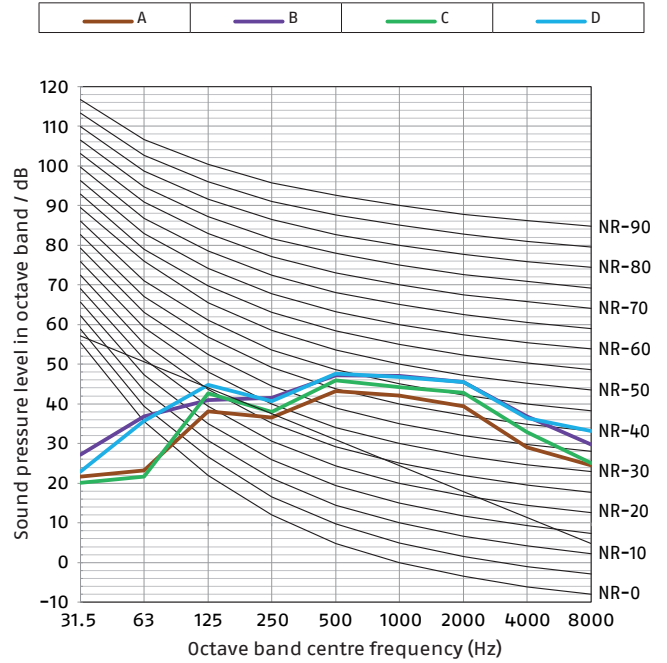

Cooling A35W18

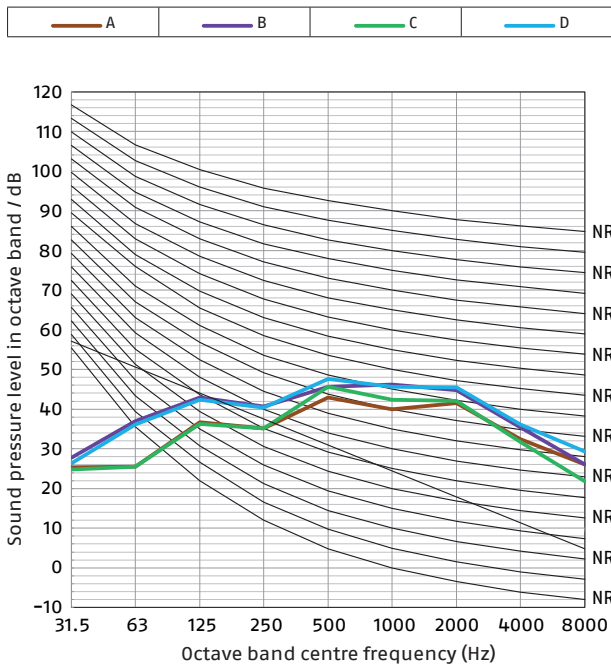

Cooling A35W7

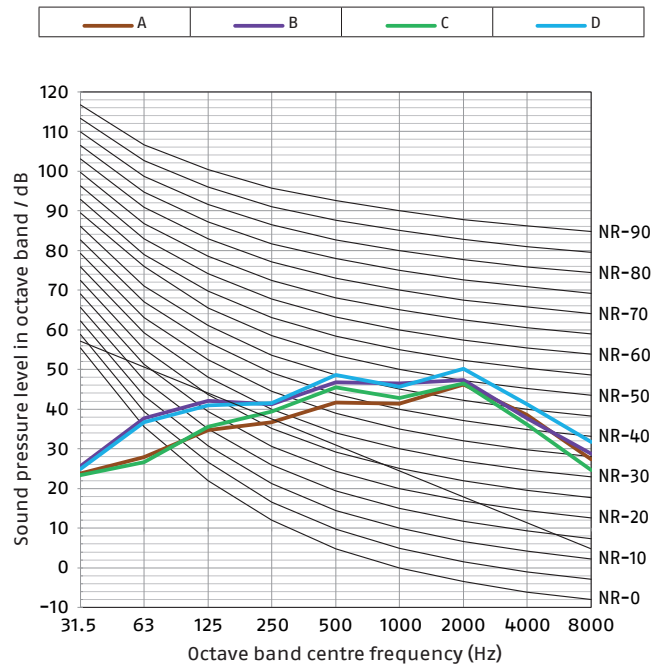

THREE-PHASE

HP EXTERNAL UNIT R32 - 12T

Heating A7W35

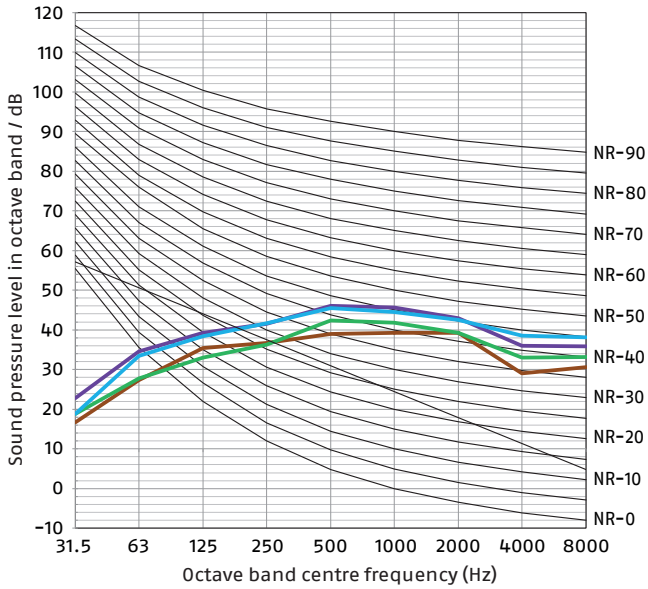

Heating A7W45

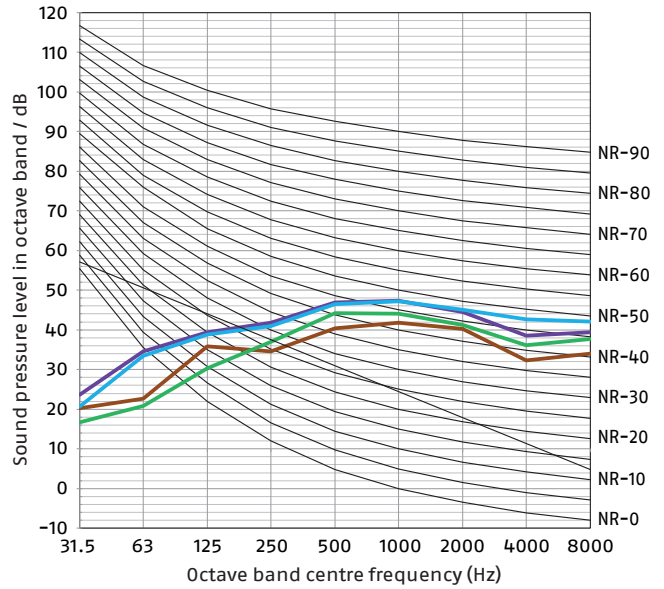

Cooling A35W18

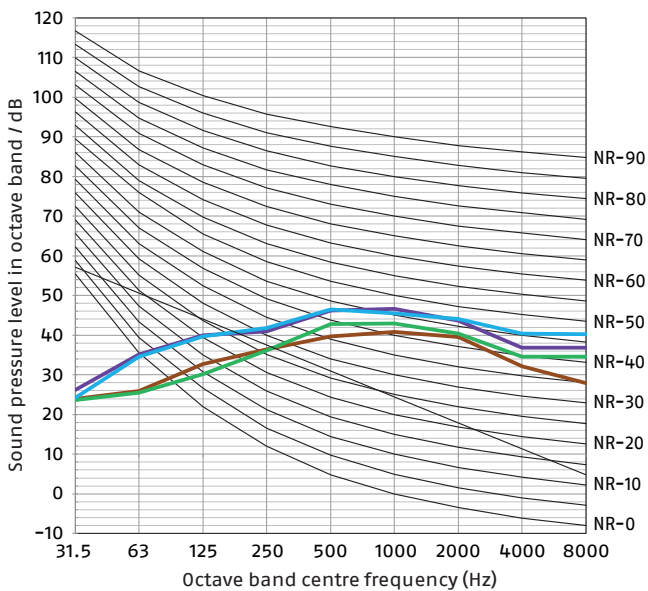

Cooling A35W7

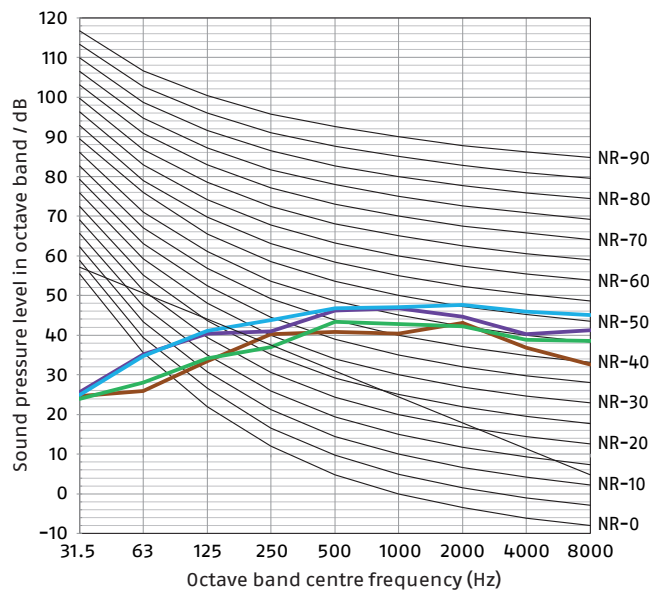

HEAT PUMPS

Floor-standing split heat pump

HP EXTERNAL UNIT R32 - 14T

Heating A7W35

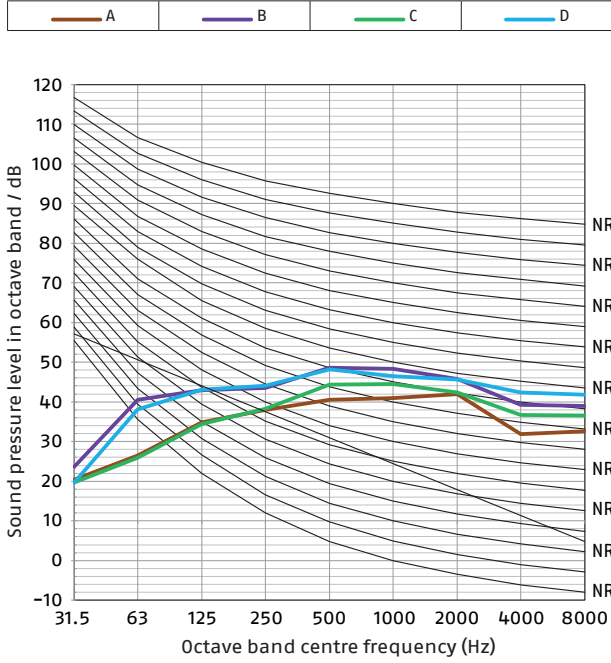

Heating A7W45

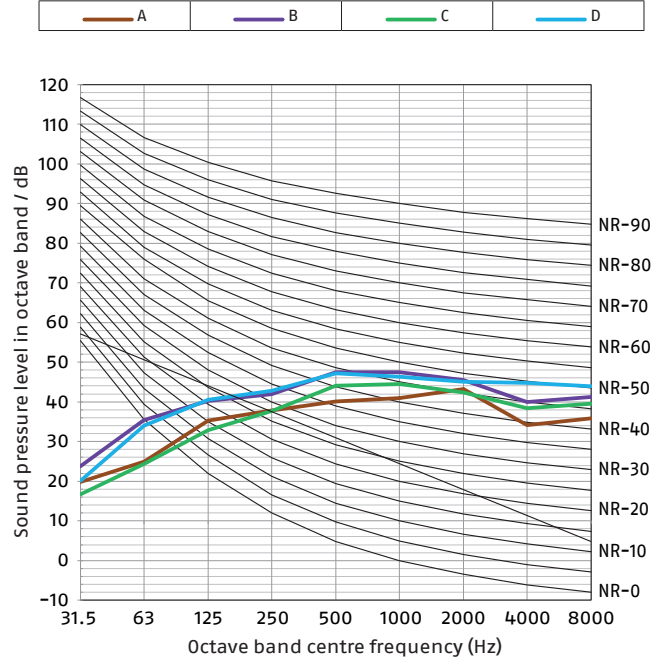

Cooling A35W18

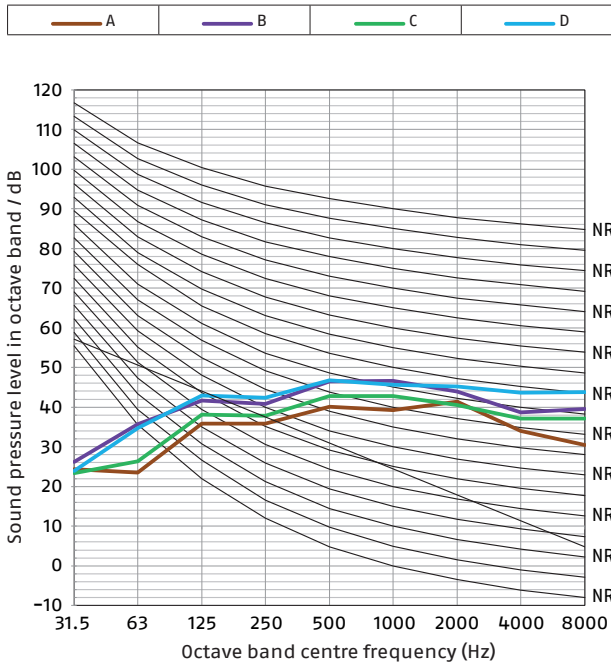

Cooling A35W7

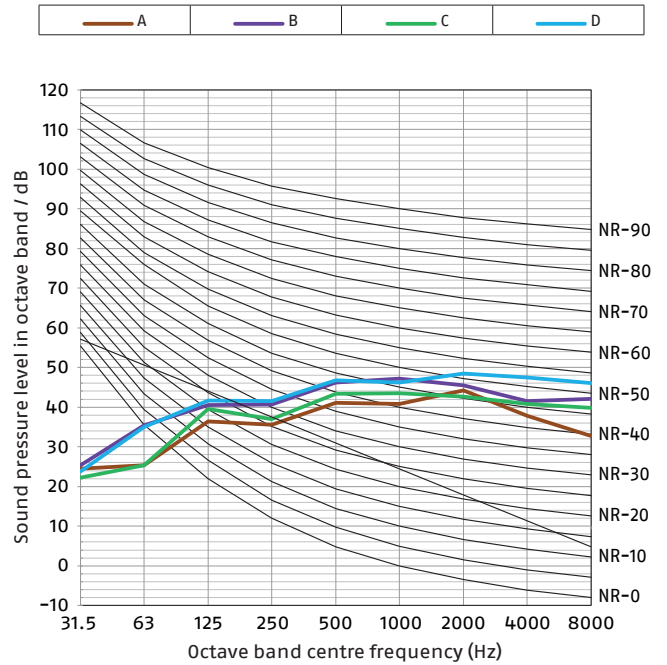

HP EXTERNAL UNIT R32 - 16T

Heating A7W35

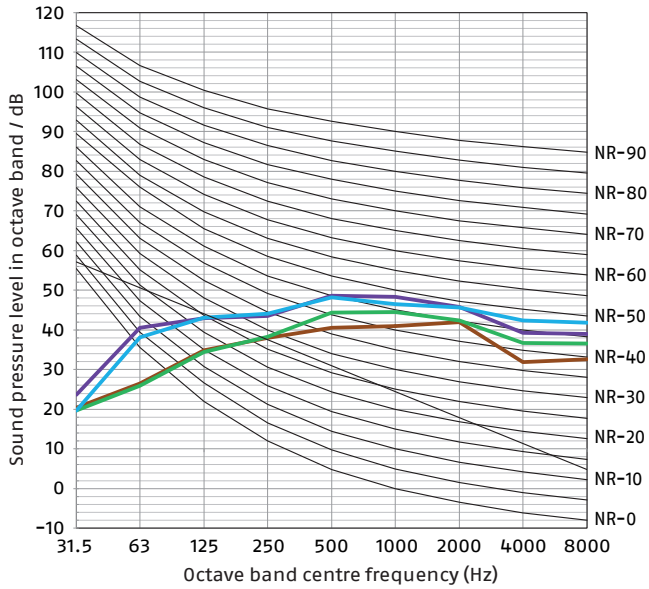

Heating A7W45

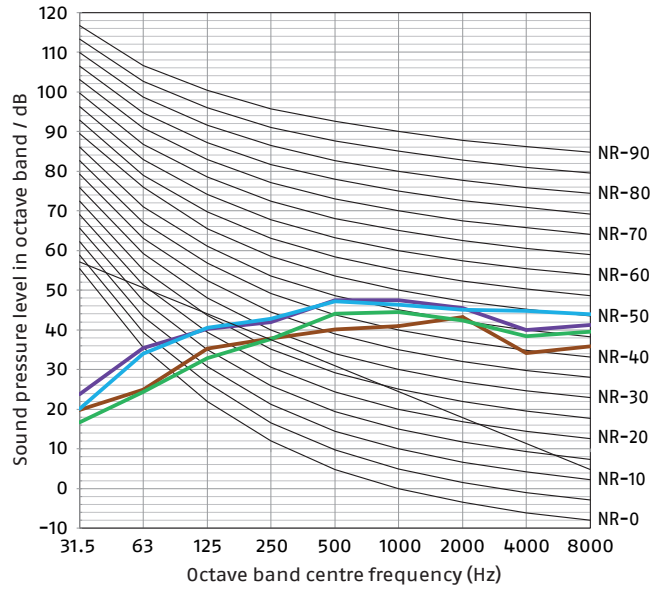

Cooling A35W18

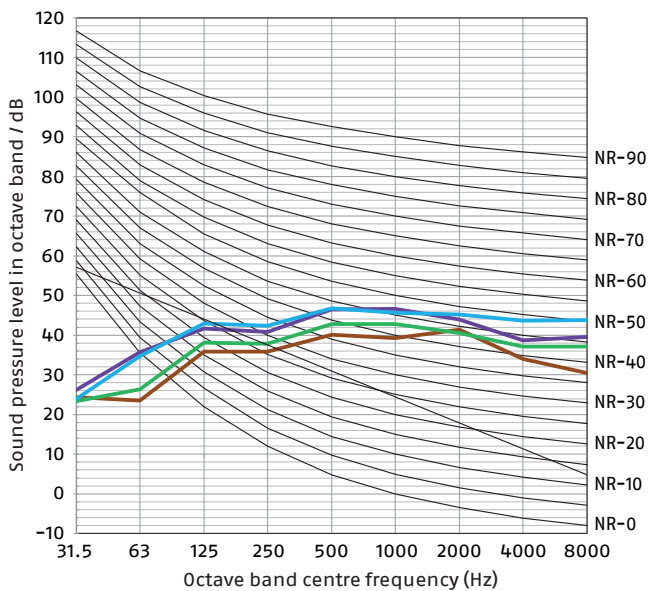

Cooling A35W7

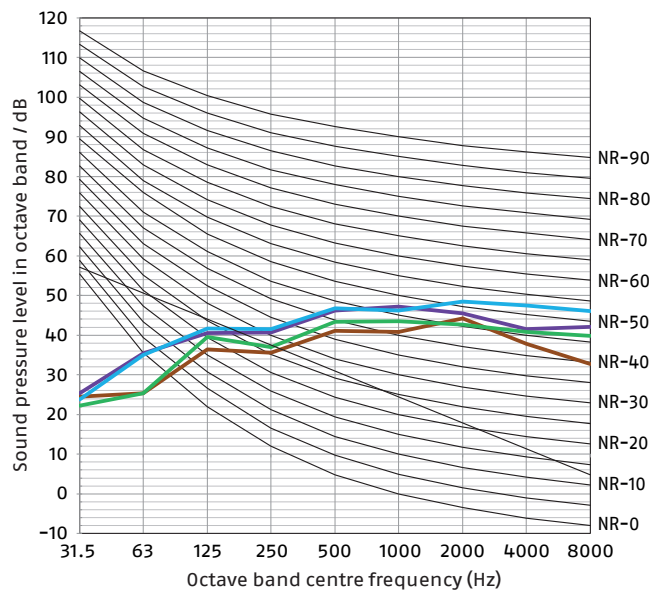

HEAT PUMPS

Floor-standing split heat pump

INDOOR UNIT

We measure noise of the unit from 4 sides as below, with a rated frequency at the distance of 1m.

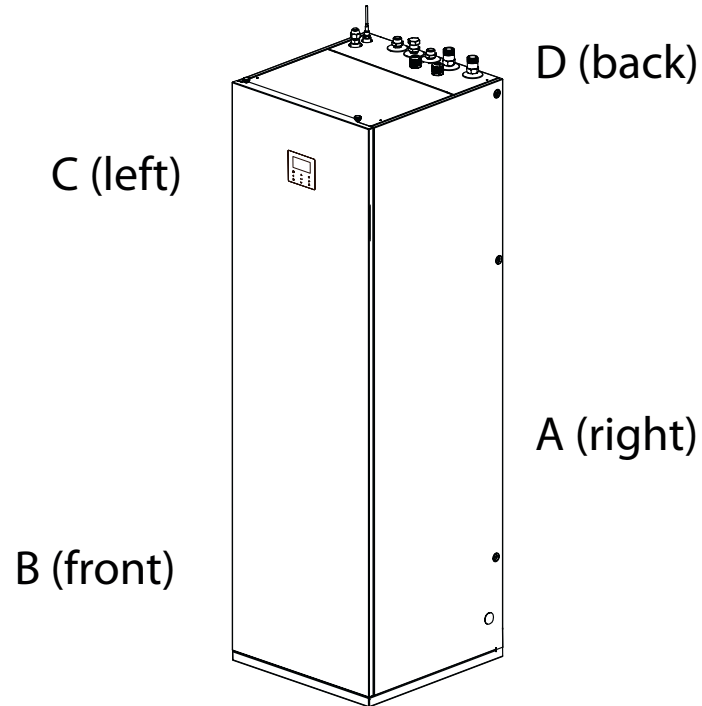

The conditions we've tested is illustrated as below:

- Heating A7W35: Evaporator air in 7°C, 85% R.H., Condenser water in/out 30/35°C
- Heating A7W45: Evaporator air in 7°C, 85% R.H., Condenser water in/out 40/45°C
- Cooling A35W18: Condenser air in 35°C. Evaporator water in/out 23/18°C
- Cooling A35W7: Condenser air in 35°C. Evaporator water in/out 12/7°C

INDOOR UNIT: 190L / 240L MODEL + OUTDOOR UNIT: 4KW

Heating A7W35

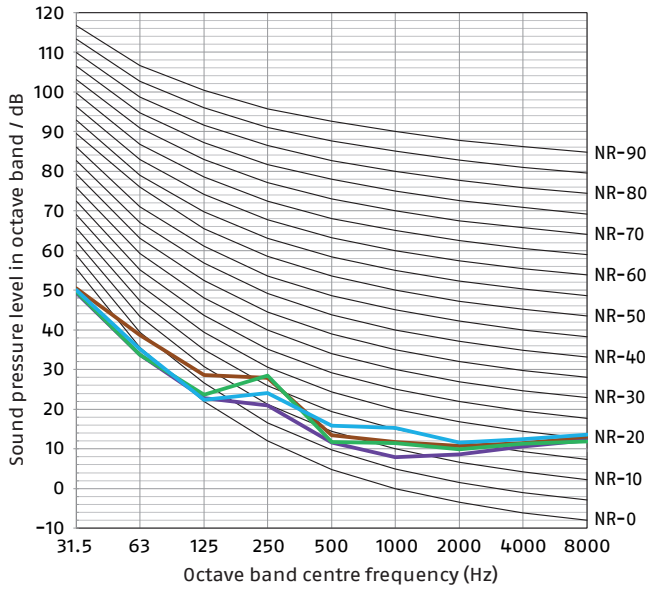

Heating A7W45

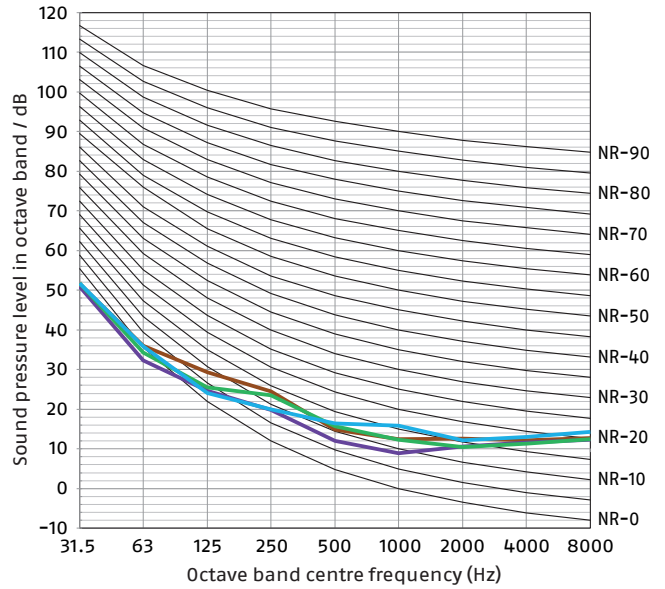

Cooling A35W18

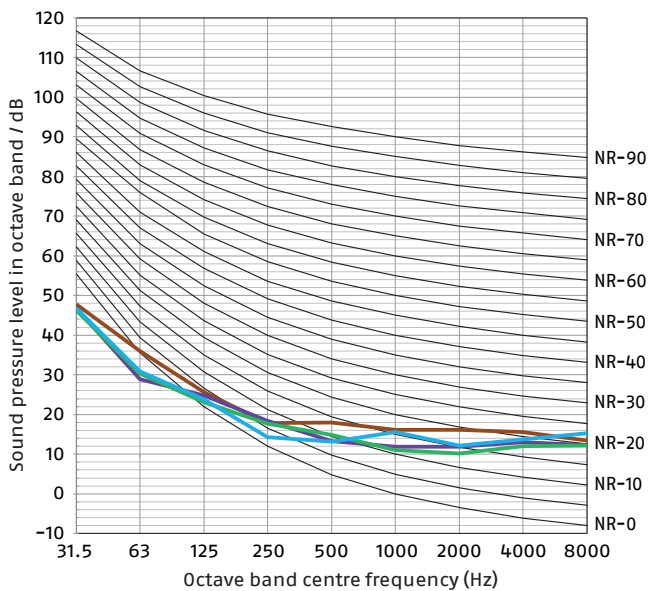

Cooling A35W7

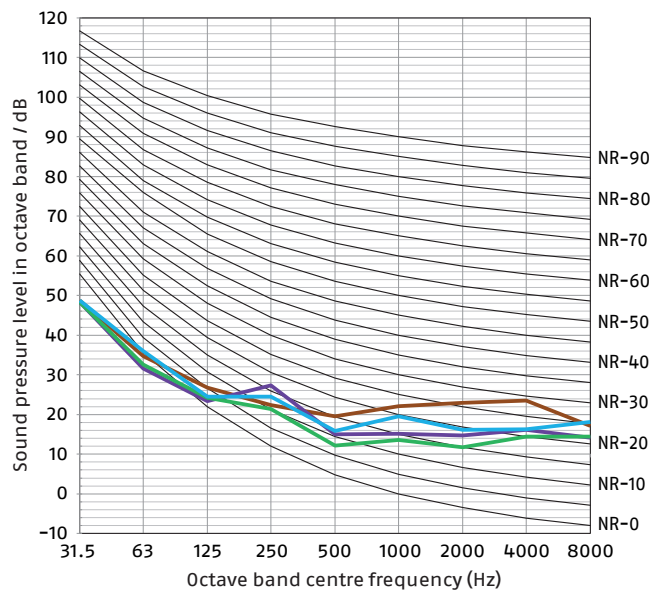

HEAT PUMPS

Floor-standing split heat pump

INDOOR UNIT: 190L / 240L MODEL + OUTDOOR UNIT: 6KW

Heating A7W35

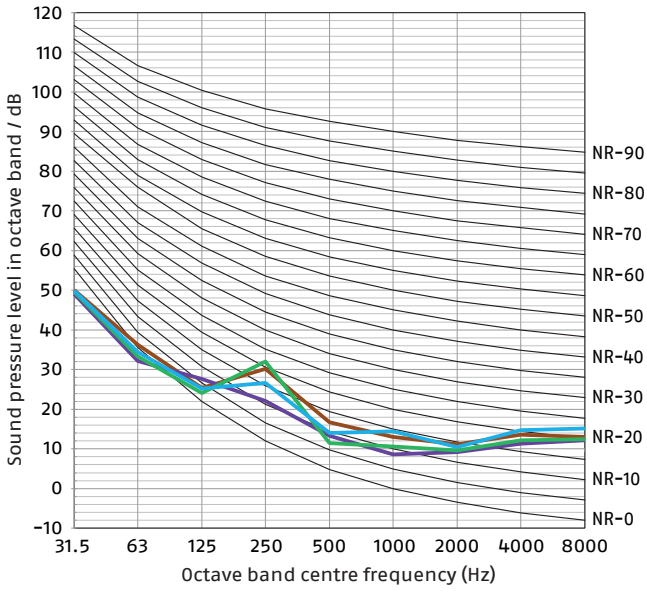

Heating A7W45

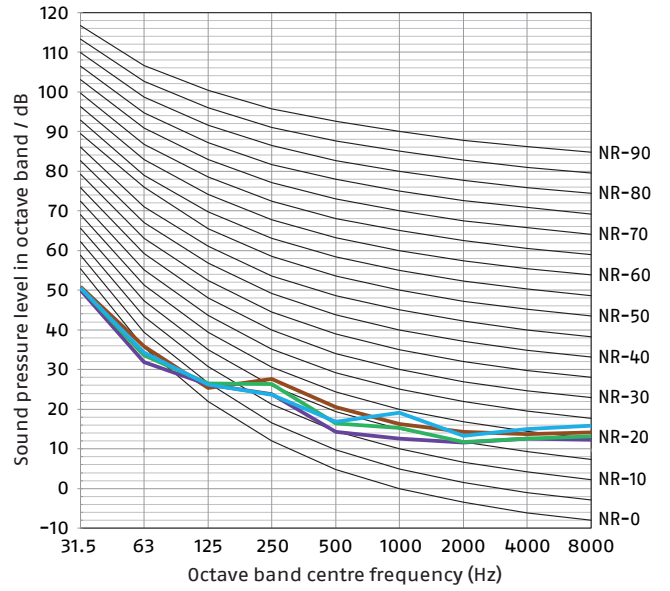

Cooling A35W18

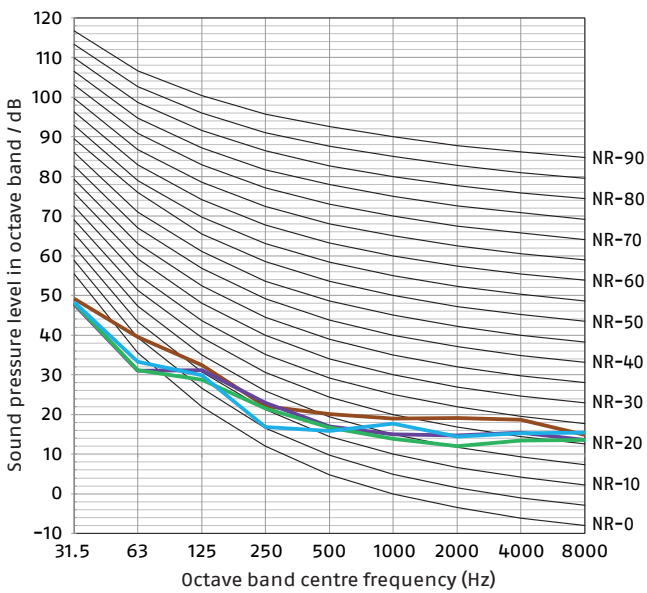

Cooling A35W7

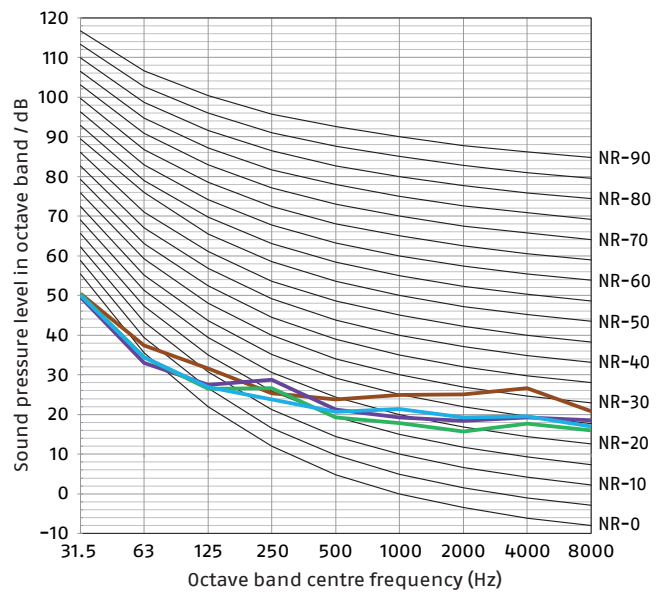

INDOOR UNIT: 190L / 240L MODEL + OUTDOOR UNIT: 8KW

Heating A7W35

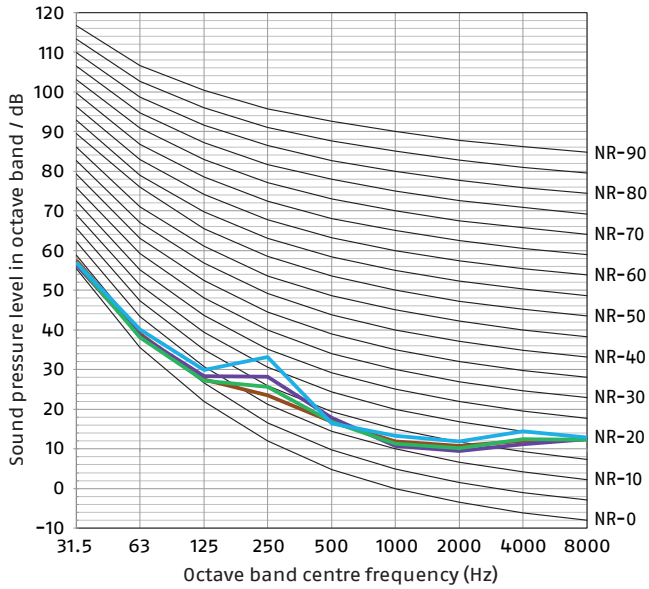

Heating A7W45

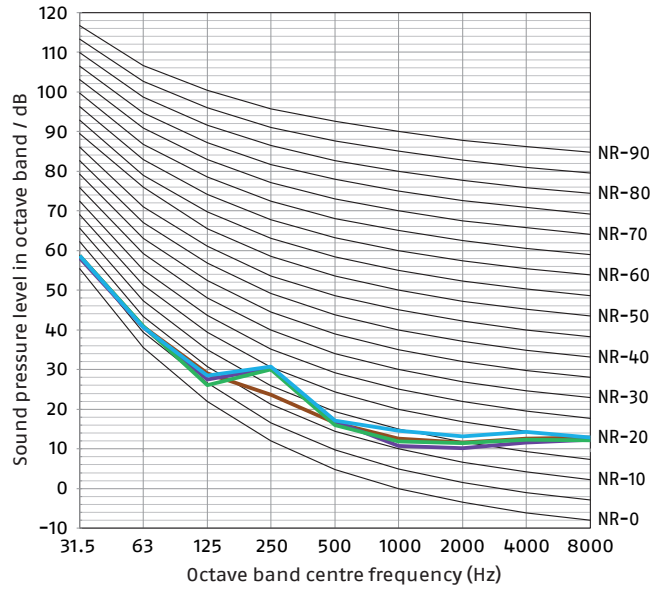

Cooling A35W18

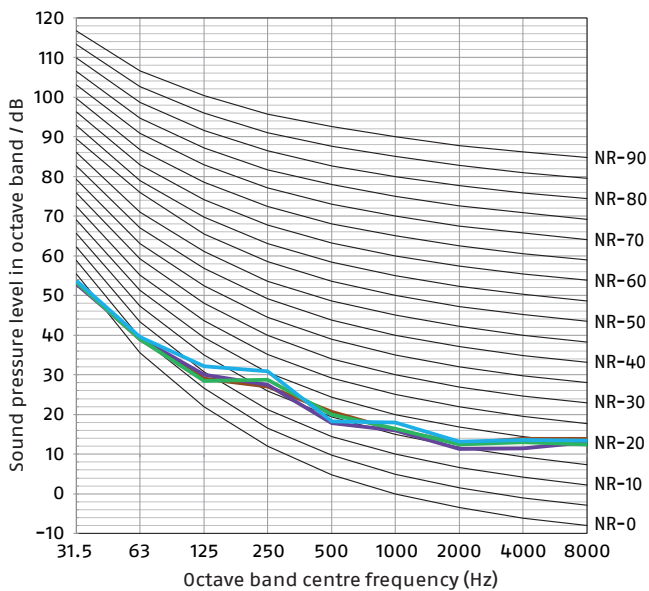

Cooling A35W7

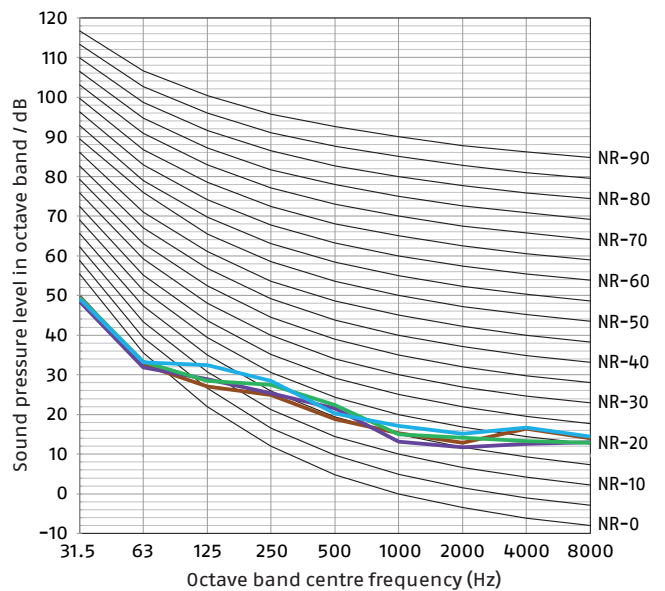

HEAT PUMPS

Floor-standing split heat pump

INDOOR UNIT: 190L / 240L MODEL + OUTDOOR UNIT: 10KW

Heating A7W35

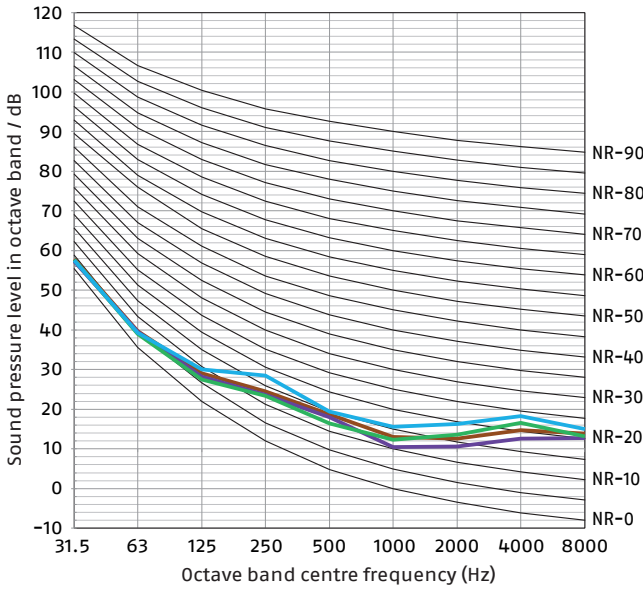

Heating A7W45

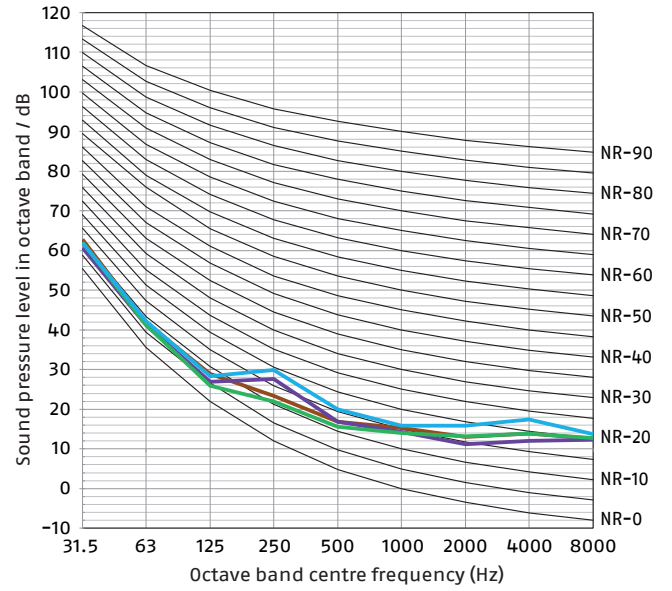

Cooling A35W18

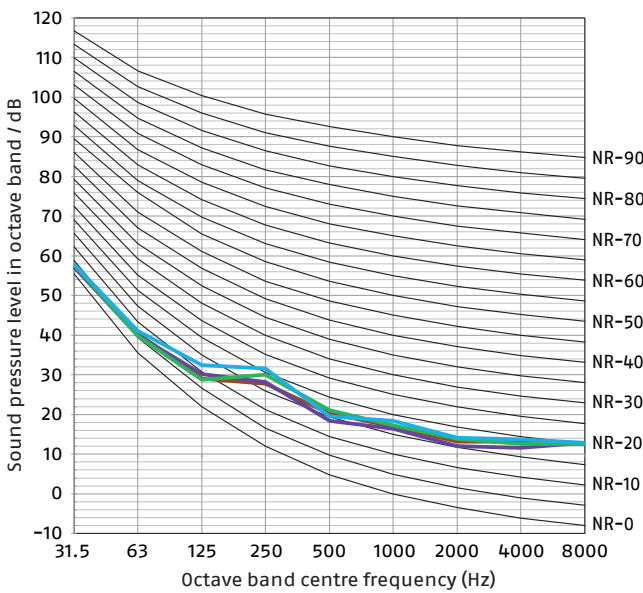

Cooling A35W7

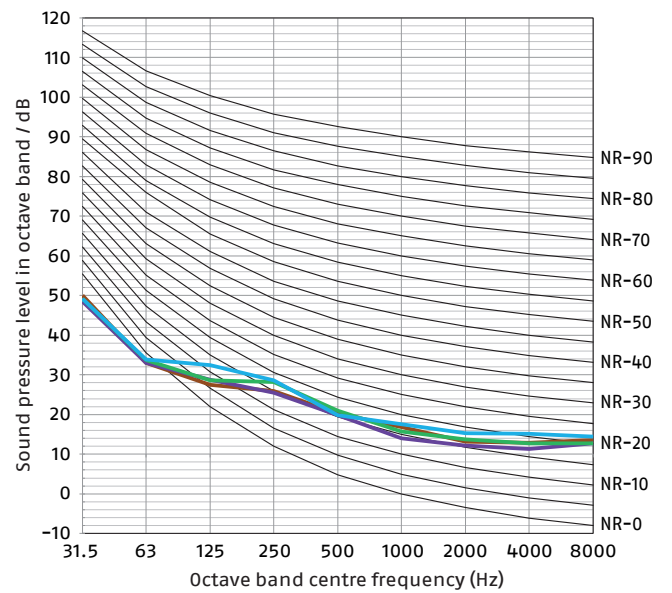

INDOOR UNIT: 240L MODEL + OUTDOOR UNIT: 12KW

Heating A7W35

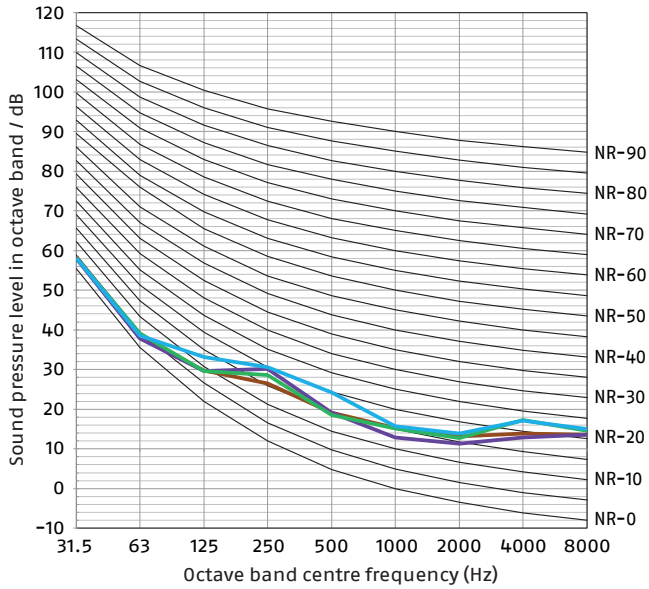

Heating A7W45

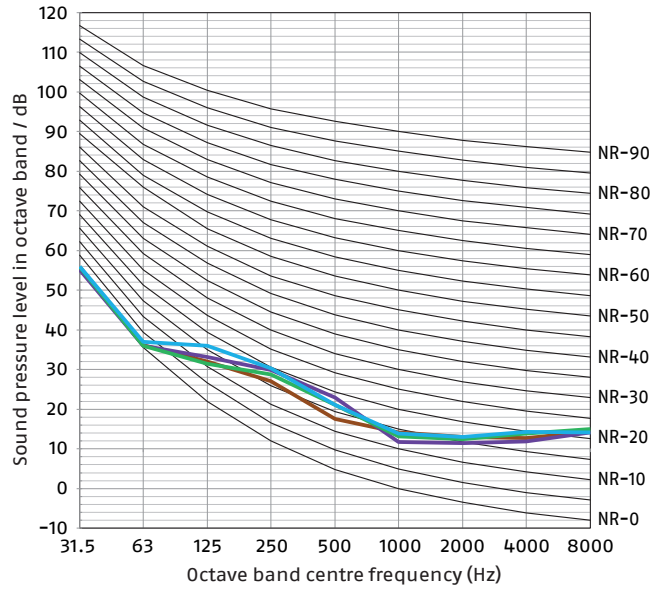

Cooling A35W18

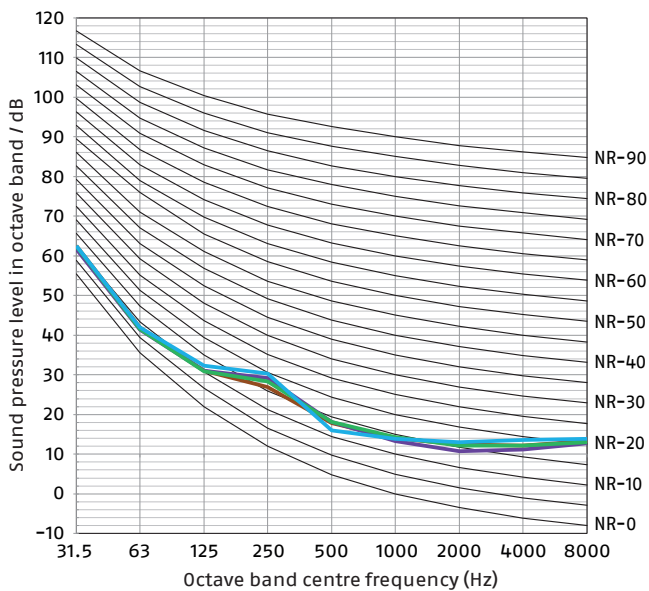

Cooling A35W7

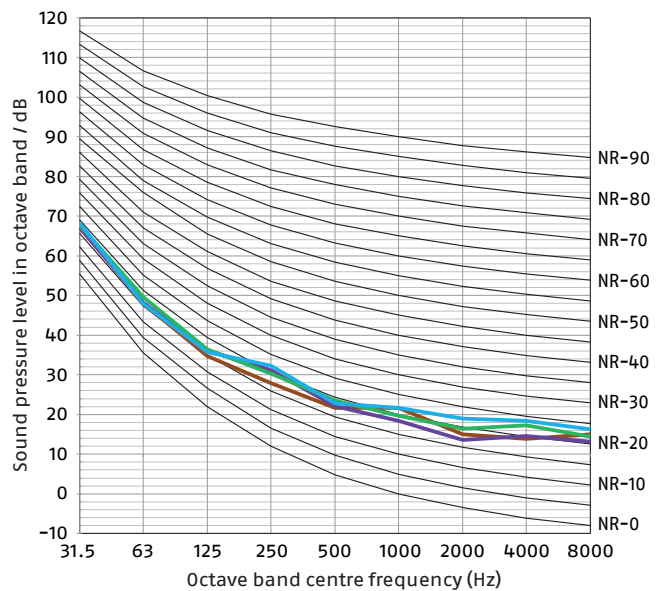

HEAT PUMPS

Floor-standing split heat pump

INDOOR UNIT: 190L / 240L MODEL + OUTDOOR UNIT: 14KW

Heating A7W35

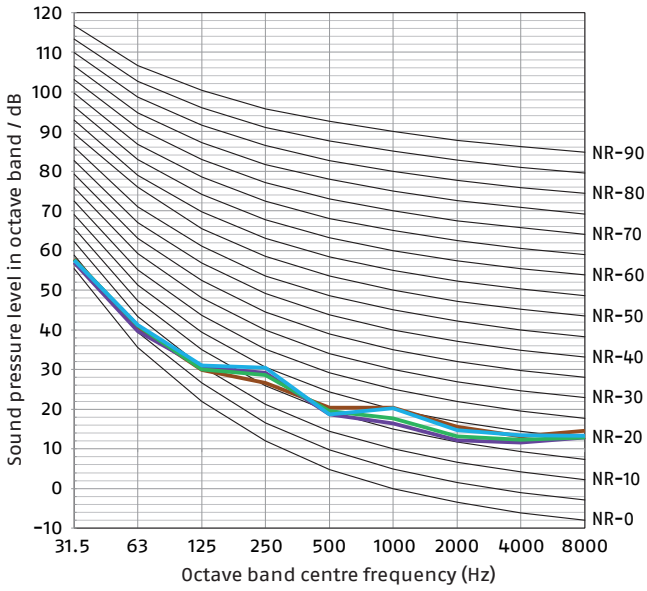

Heating A7W45

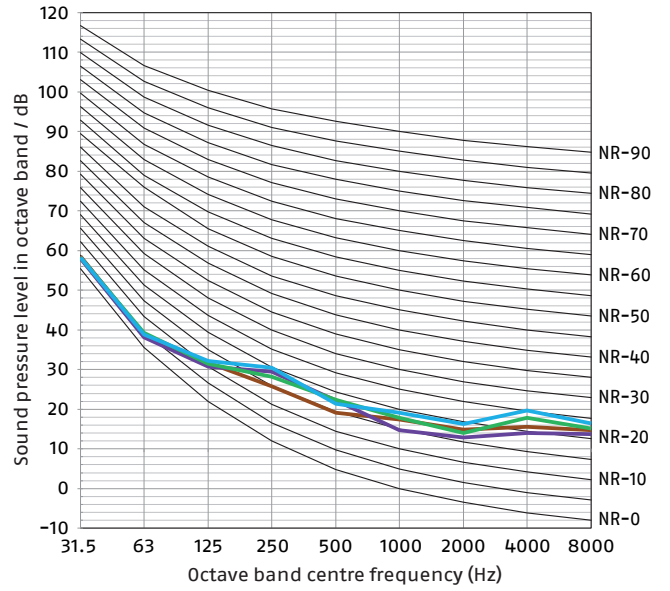

Cooling A35W18

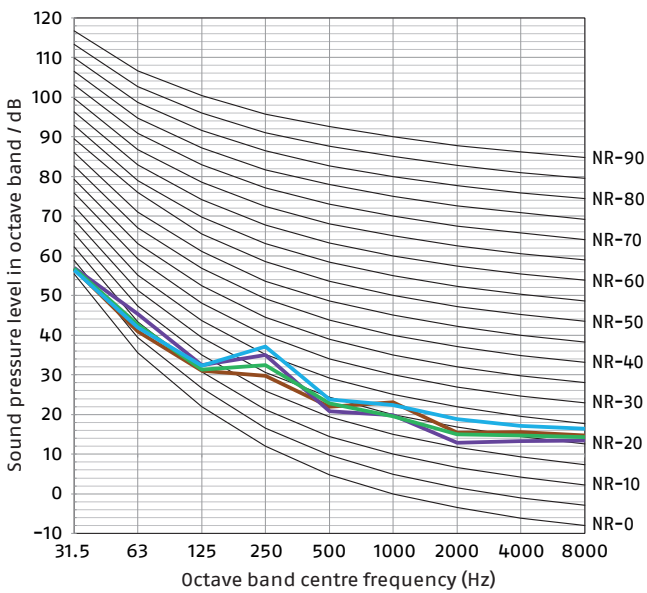

Cooling A35W7

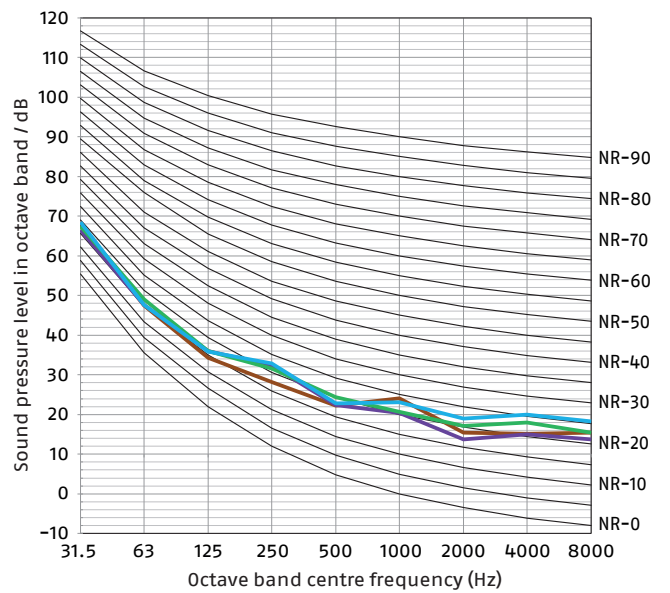

INDOOR UNIT: 240L MODEL + OUTDOOR UNIT: 16KW

Heating A7W35

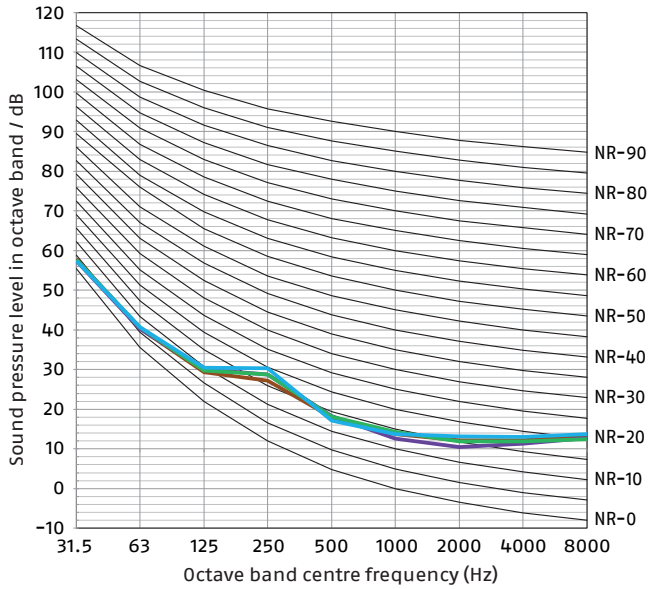

Heating A7W45

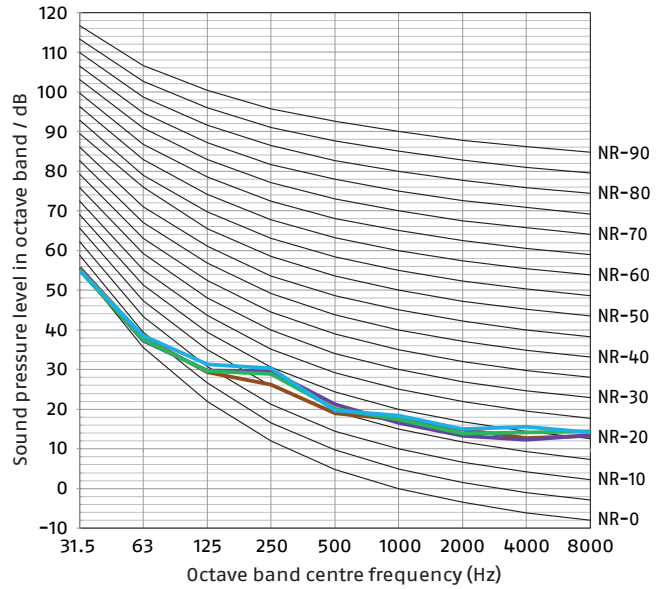

Cooling A35W18

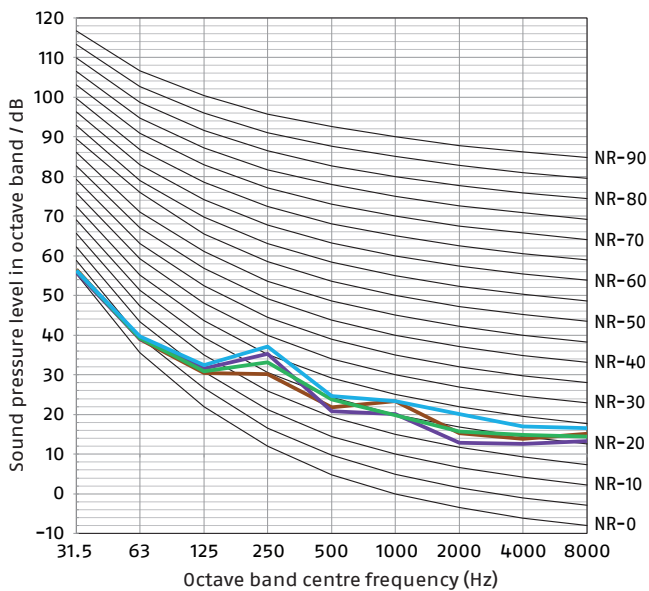

Cooling A35W7

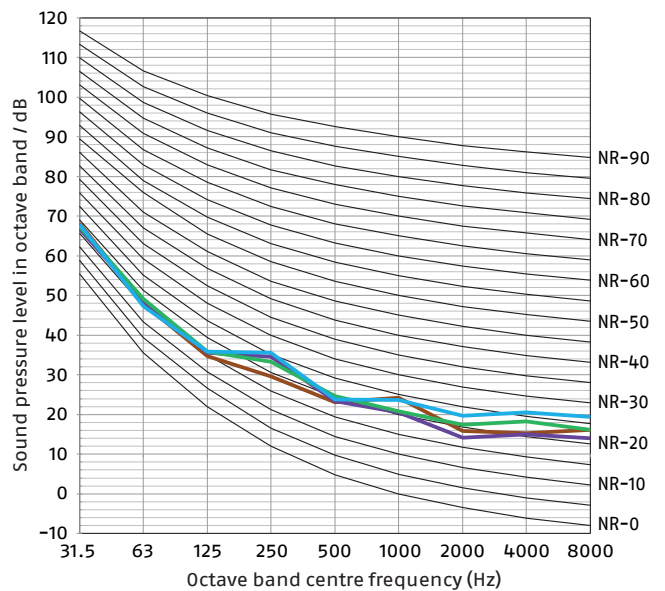

HEAT PUMPS

Floor-standing split heat pump

OVERALL DIMENSIONS AND WEIGHTS

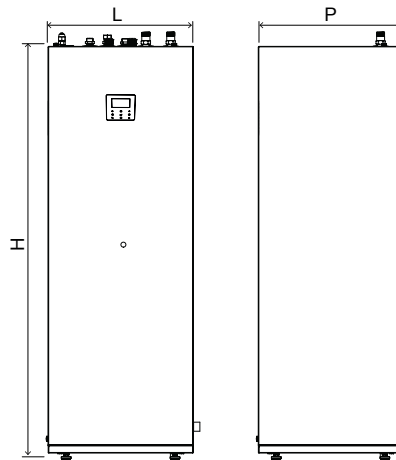

INDOOR UNITS

Models		U.M.	HP IDU DOMUS					
Indoor unit			M31/ 04-10	M61/ 04-10	L31/ 04-10	L61/ 04-10	L61/ 12-16	L93/ 12-16
Height	H	mm	1683	1683	1943	1943	1943	1943
Width	L	mm	600	600	600	600	600	600
Depth	P	mm	600	600	600	600	600	600
Net weight		kg	140	140	157	157	158	159

HP EXTERNAL UNIT 004-006

HP EXTERNAL UNIT 008÷016 - 012T÷016T

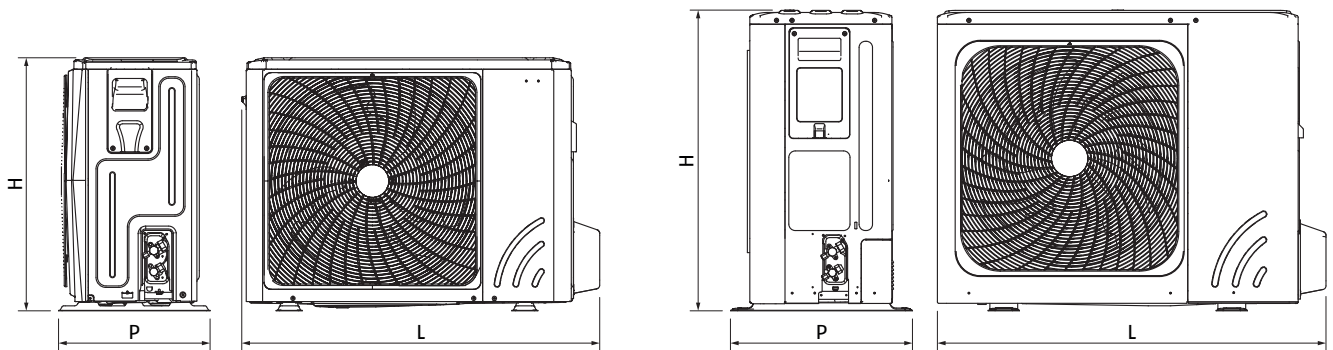

OUTDOOR UNITS

Models		U.M.	HP ODU SPRINT									
Outdoor unit			004	006	008	010	012	014	016	012T	014T	016T
Height	H	mm	1008	1008	1118	1118	1118	1118	1118	1118	1118	1118
Width	L	mm	712	712	865	865	865	865	865	865	865	865
Depth	P	mm	426	426	523	523	523	523	523	523	523	523
Net weight		kg	58	58	75	75	97	97	97	112	112	112
Gross weight		kg	63.5	63.5	89	89	110.5	110.5	110.5	125.5	125.5	125.5

PLACE OF INSTALLATION

PRELIMINARY WARNINGS FOR R32

The appliance must be installed in a well-ventilated room with the minimum floor area stated in the Minimum Floor Area table, in accordance with the overall refrigerant load in the circuit.

Refrigerant load refers to the overall load in the circuit calculated by adding the factory load and any additional load. See the nameplate on the paired outdoor unit for the quantity of refrigerant gas loaded in the unit.

If the appliance is to be installed in a poorly ventilated room, steps must be taken to prevent stagnation in the event of refrigerant leakage, so as not to create a risk of fire or explosion.

The appliance must be installed in a room where there are no open flames continuously in operation (e.g. a gas appliance running) or ignition sources (e.g. an electric heater running).

Any vents must be kept clear of obstacles.

Run the following checks:

- - run safety checks to ensure the combustion risk is reduced to a minimum
- - avoid working in confined spaces
- - delimit the area around the work space
- - ensure safe working conditions around the area by controlling flammable material.

INDOOR UNIT

MINIMUM FLOOR AREA

Total refrigerant charge (kg)	Minimum floor area (m ²)	
	Model M31 & M61 (190L DHW tank)	Model L31, L61 & L93 (240L DHW tank)
1.85	6.90	4.70
1.90	7.31	4.92
1.95	7.70	5.18
2.00	8.10	5.45
2.05	8.51	5.72
2.10	8.93	6.01
2.15	9.36	6.30
2.20	9.80	6.59
2.25	10.30	6.89
2.30	10.70	7.20
2.35	11.20	7.52
2.40	11.70	7.84
2.45	12.20	8.10

Note: if the total R32 refrigerant charge in the system is <1.84kg, there are no additional minimum floor area requirements.

The clearances for appliance assembly and maintenance are shown in the figure. These clearances are necessary to avoid blocking the air flow and to allow normal cleaning and maintenance.

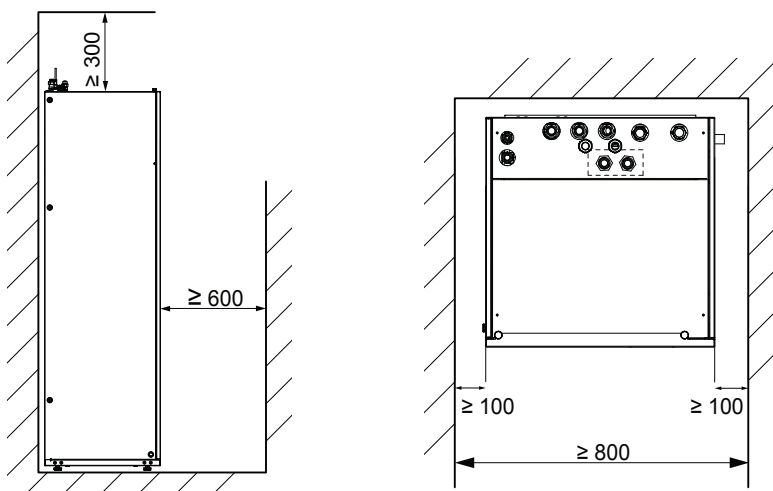

Dimensions in mm.

HEAT PUMPS

Floor-standing split heat pump

MOUNTING THE INDOOR UNIT

Ensure the unit is mounted securely. Adjust the height of the leveling feet which can be adjusted up to 30mm to compensate for floor irregularities. The maximum allowed deviation is 1°.

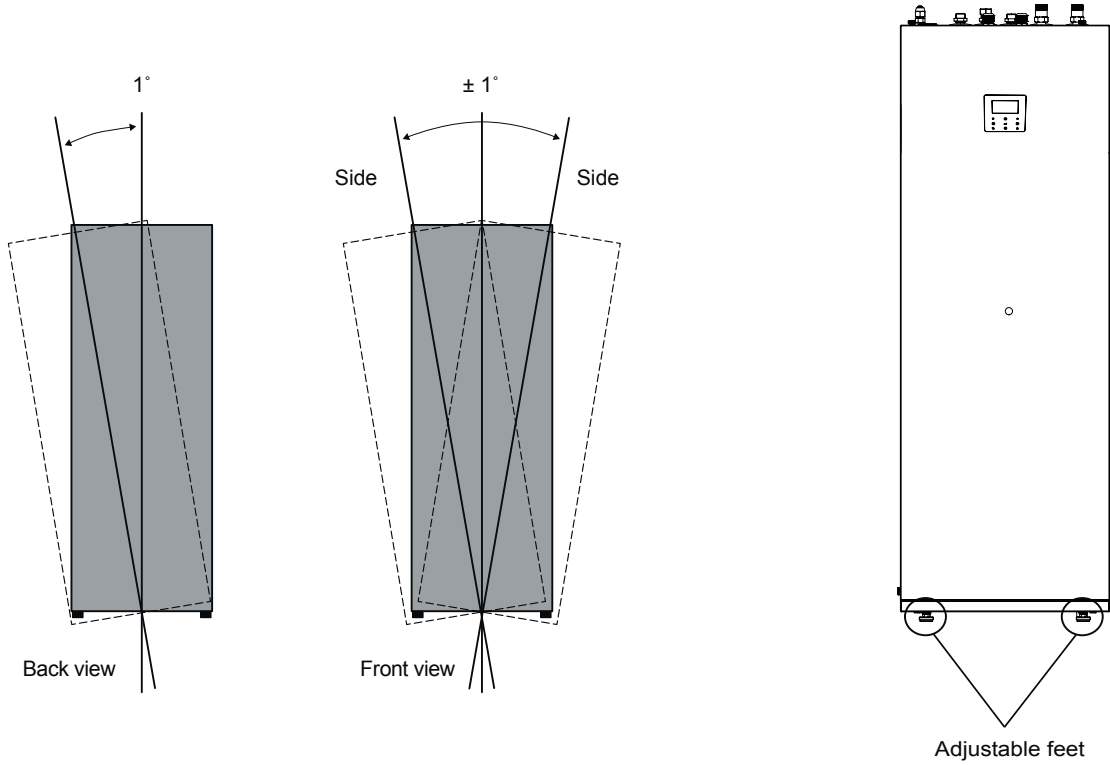

OUTDOOR UNIT

The clearances for appliance assembly and maintenance are shown in the figure. These clearances are necessary to avoid blocking the air flow and to allow normal cleaning and maintenance.

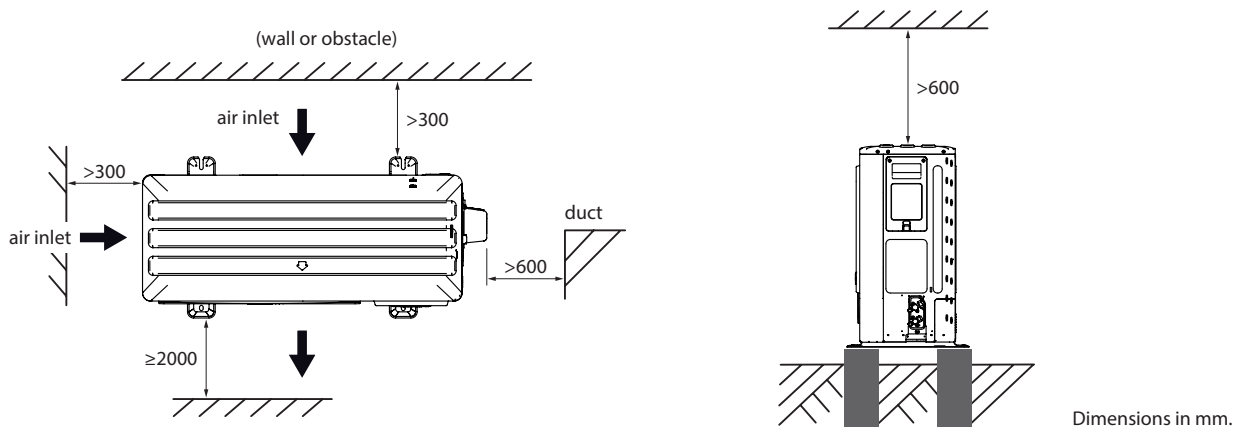

In a cold climate

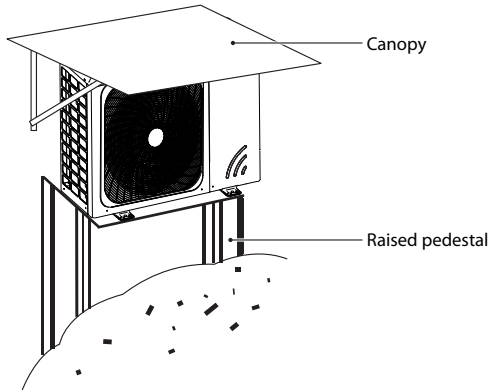

In a stacked installation

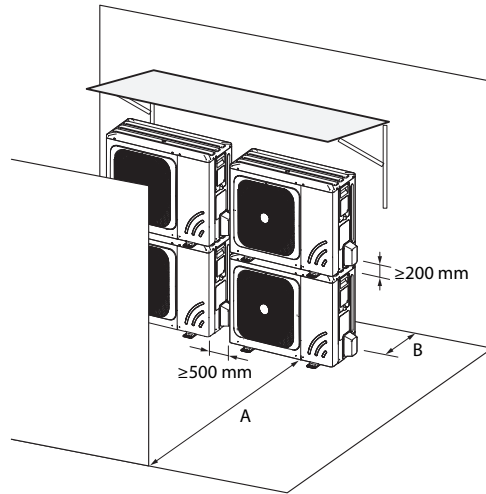

	A	B
	mm	mm
HP EXTERNAL UNIT 004÷016	≥ 2000	≥ 2000

When installed in rows

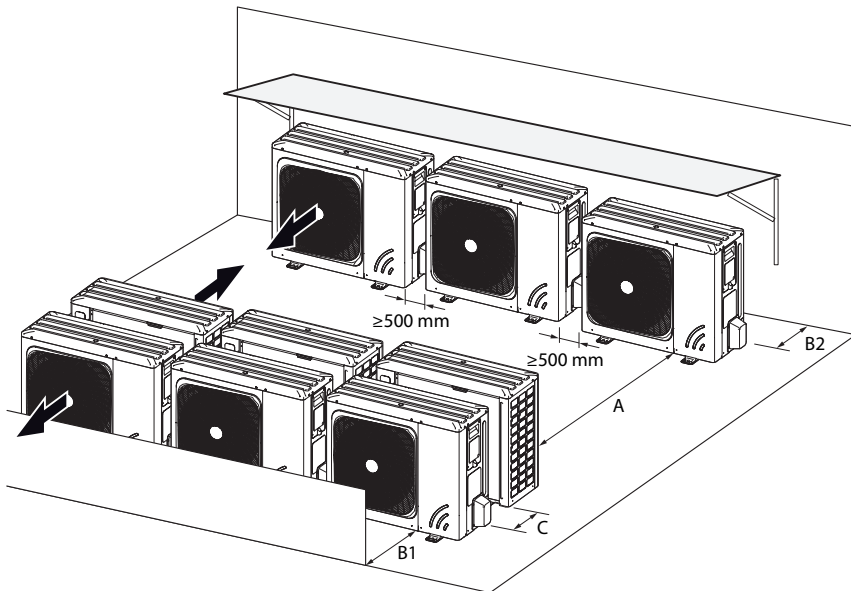

	A	B1	B2	C
	mm	mm	mm	mm
HP EXTERNAL UNIT 004÷016	≥ 2000	≥ 2000	≥ 300	≥ 600

HEAT PUMPS

Floor-standing split heat pump

STRUCTURE

INDOOR UNIT

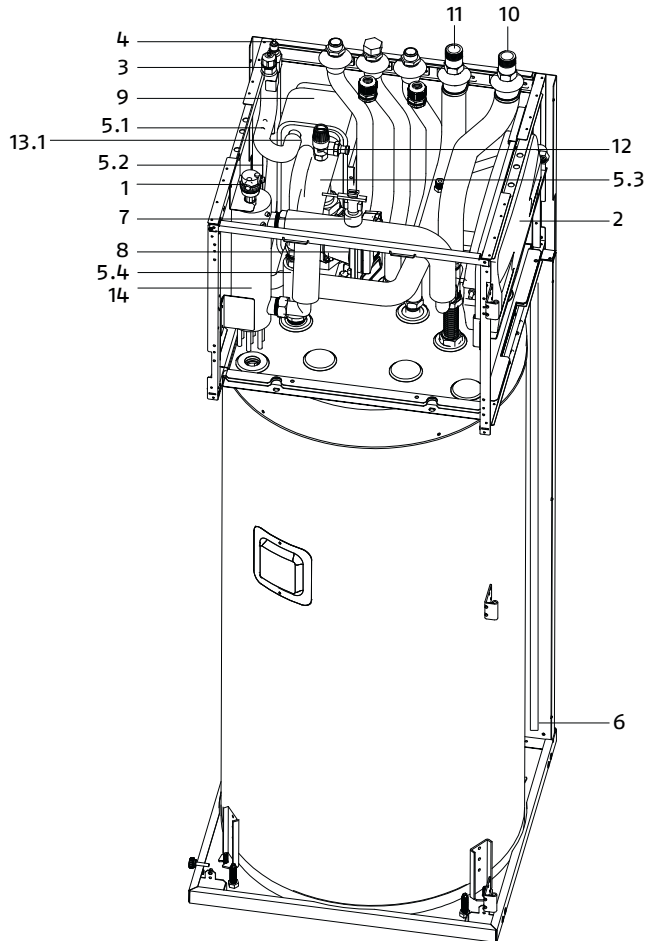

- 1 Automatic air purge valve
- 2 Expansion vessel (8 L)
- 3 Refrigerant gas pipe
- 4 Refrigerant liquid pipe
- 5 Temperature sensors (5.1-5.2-5.3-5.4-5.5)
- 6 Drainage port
- 7 Flow switch
- 8 Circulation pump
- 9 Plate heat exchanger
- 10 Water outlet pipe
- 11 Water inlet pipe
- 12 Pressure relief valve
- 13 Electrical heating belt (13.1)
- 14 Internal backup heater

OUTDOOR UNIT

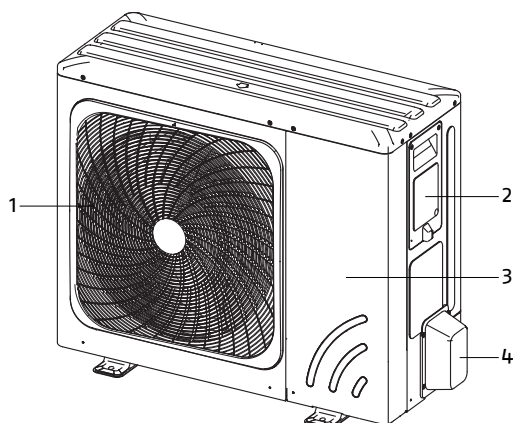

- 1 Electric fan grille
- 2 Electrical connections panel
- 3 Access panel
- 4 Hydraulic connections panel

HYDRAULIC AND REFRIGERATION CONNECTIONS

INDOOR UNITS

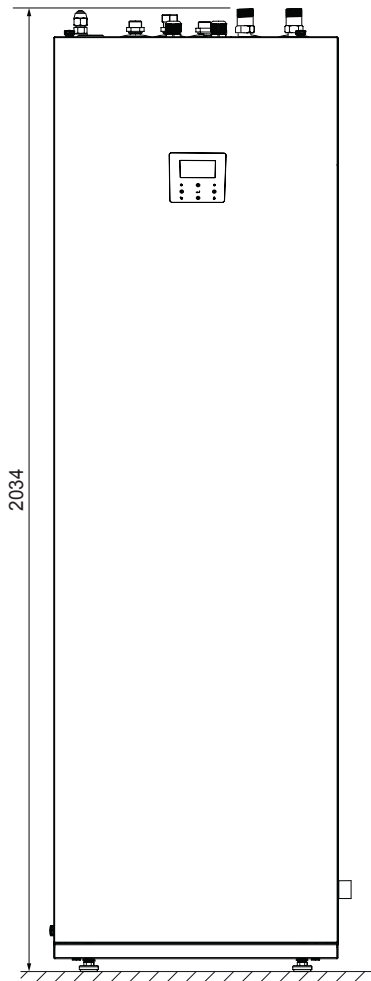
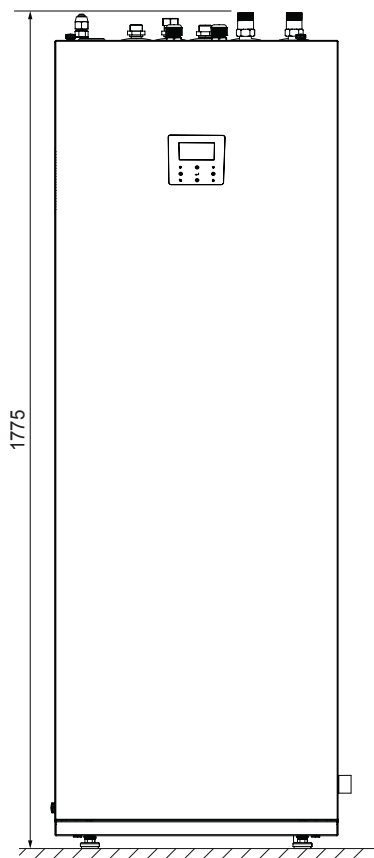
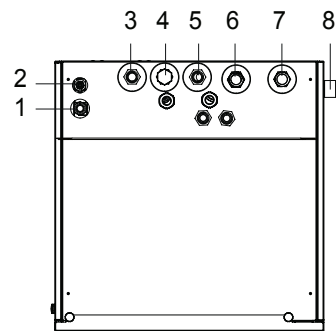
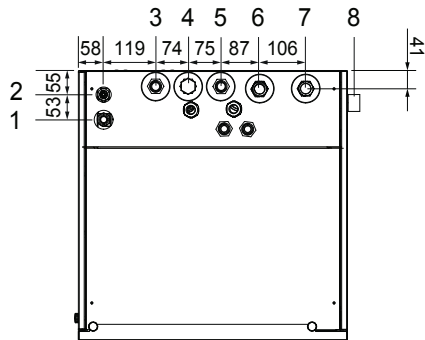

- 1 Refrigerant gas connection 5/8"-14UNF
- 2 Refrigerant liquid connection 3/8"-14UNF
- 3 Domestic hot water outlet R3/4"
- 4 Domestic hot water recirculation water inlet (plugged by the nut) R3/4"

- 5 Domestic cold water inlet
- 6 Space heating (cooling) water inlet R1"
- 7 Space heating (cooling) water outlet R1"
- 8 Drainage Ø25

Connections valid for both versions with 190L and 240L DHW tank.

HEAT PUMPS

Floor-standing split heat pump

OUTDOOR UNIT

HP EXTERNAL UNIT 004-006

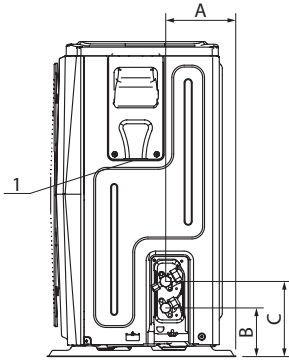

View from below

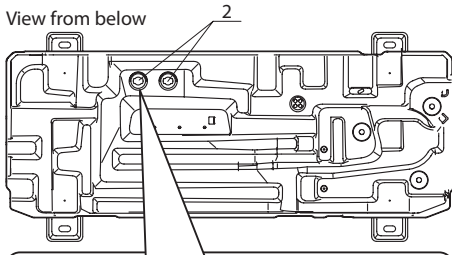

This drain hole is covered by a rubber stopper. If one drain hole cannot meet requirements, the other one can also be used at the same time.

HP EXTERNAL UNIT 008÷016 – 012T÷016T

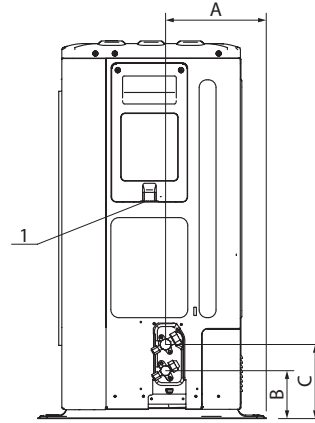

View from below

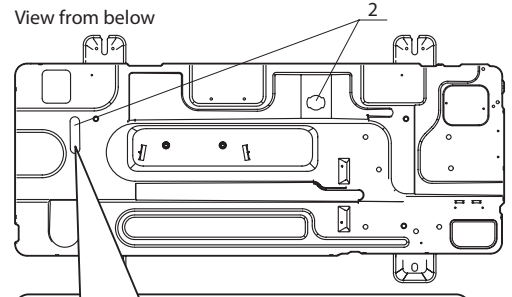

This drain hole is covered by a rubber stopper. If the small drain hole cannot meet the drainage requirements, the large drain hole can be used at the same time.

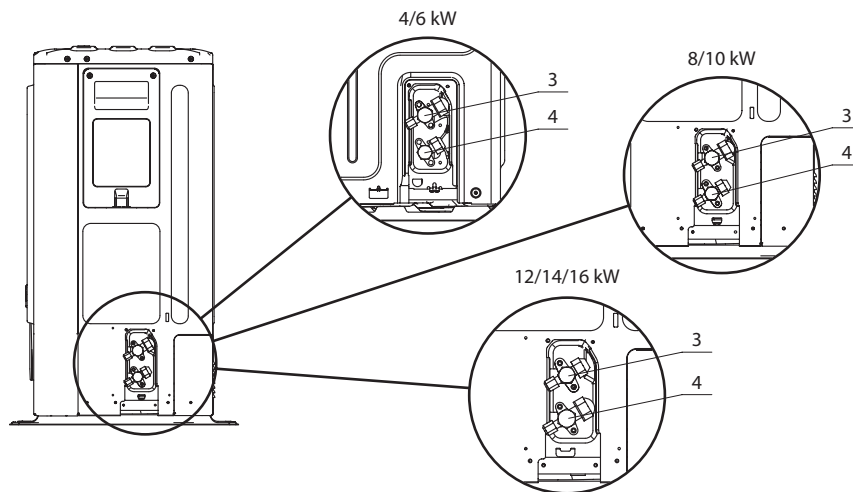

	Model	U.M.	HP EXTERNAL UNIT 004-006	HP EXTERNAL UNIT 008÷016 – 012T÷016T
1	Hole for electrical connections	∅ mm	-	-
2	Condensate outlet hose fitting (included)	∅ mm	-	-
3	Refrigerant gas fitting	inches	∅5/8"	∅5/8"
		mm	∅15.88	∅15.88
4	Refrigerant liquid fitting	inches	∅1/4"	∅3/8"
		mm	∅6.35	∅9.52
A		mm	160	230
B		mm	110	110
C		mm	170	170

REFRIGERANT CONNECTIONS BETWEEN OUTDOOR UNIT AND INDOOR UNIT

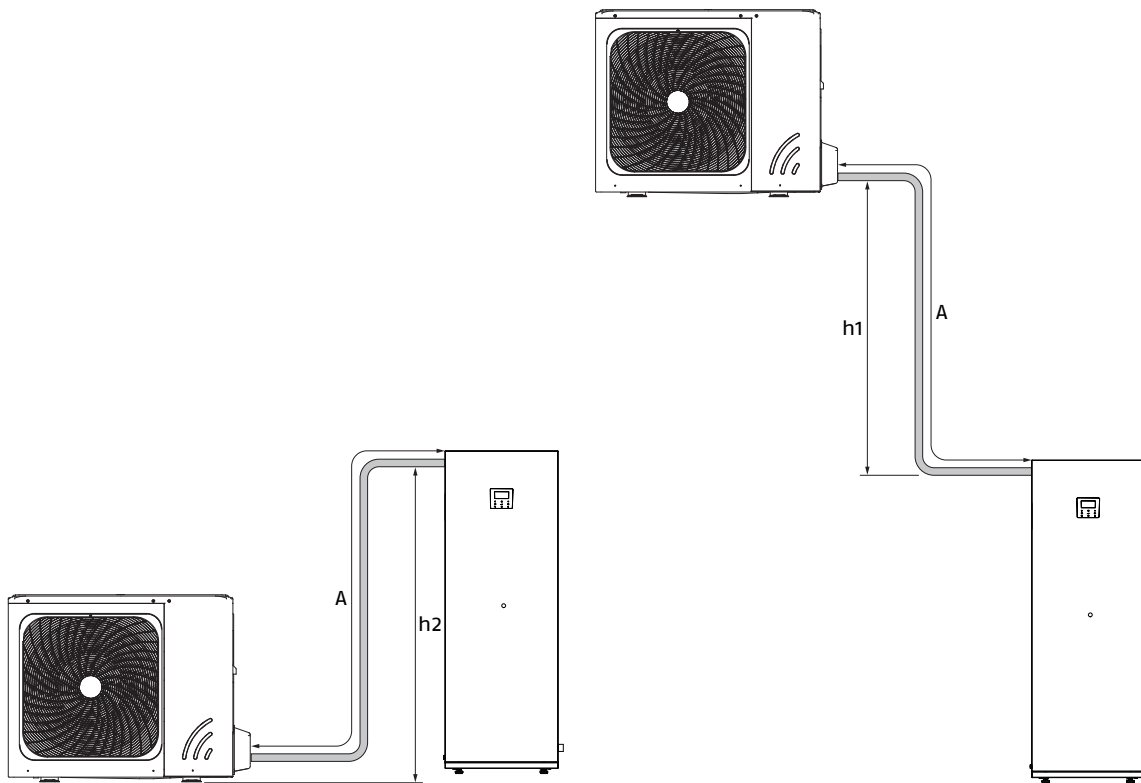

	Model	U.M.	4÷6 kW	8÷16 kW
Maximum permitted length	A	m	30	30
Permissible height difference between the 2 units if outdoor unit is positioned higher	h_1	m	20	20
Permissible height difference between the 2 units if outdoor unit is positioned lower	h_2	m	20	20
Length of connecting pipes without additional gas load		m	≤ 15	≤ 15
Additional load		g/m	20	38

HEAT PUMPS

Floor-standing split heat pump

FLOW RATE, HEAT LOAD LOSS

Domus M is equipped with a variable-speed circulation pump. The speed of rotation depends on the input signal. The relationships between the heat and the water flow rate, the PMW return and the water flow rate are shown in the graph below.

Model	U.M.	004	006	008	010	012	014	016	12T	14T	16T
Nominal flow	m ³ /h	0,73	1,07	1,43	1,72	2,08	2,49	2,75	2,08	2,49	2,49
Useful head at nominal flow	Kpa	75	74	63	45	21	*	*	*	*	*

(*) For 14kW and 16kW models, it is mandatory to install a technical water buffer as hydraulic separator immediately after the machine water outlet. For the temperature control on the secondary circuit, also add the temperature probe for the buffer which is available among the accessories. The unit manages the secondary circulator as standard, which must be installed for the declared performance of the system.

When sizing the system, take account of the residual heat shown in the graphs below:

Nominal flow rate
Indoor unit 190L

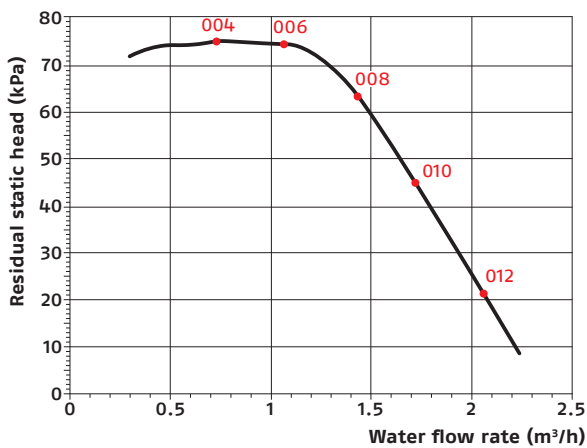

Nominal flow rate
Indoor unit 240L

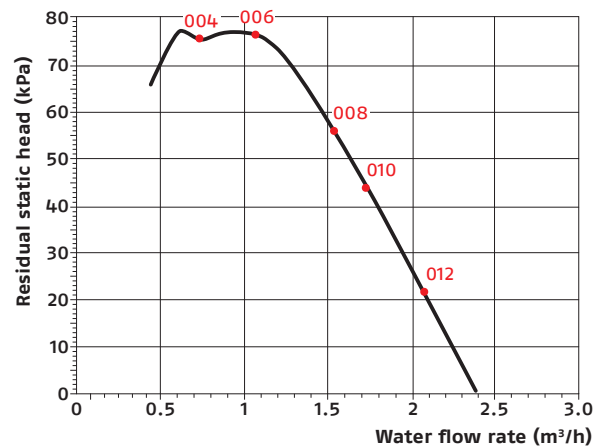

FLOW DIAGRAM – ABSORBED POWER

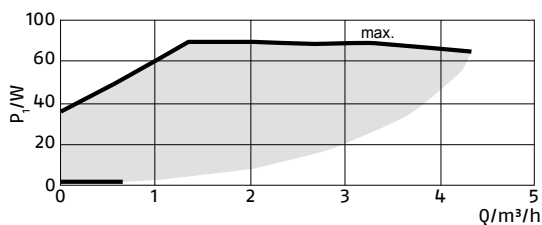

HYDRAULIC SYSTEM

QUALITY REQUIREMENTS FOR SYSTEM FILLING WATER

During the first start-up, the specialised technician must measure the reference values of the water in the system using the appropriate test kits.

The water quality must comply with the requirements listed in the following table, otherwise a treatment system must be provided.

Reference values of system water		
pH		6,5 ÷ 7,8
Electric conductivity	µS/cm	250 ÷ 800
Total hardness	°F	5 ÷ 15
Total iron	ppm	0.2
Manganese	ppm	< 0,05
Chlorides	ppm	< 250
Sulphur ions		none
Ammonia ions		none

Well or groundwater not coming from the waterworks must always be analysed carefully and, if necessary, conditioned with appropriate treatment systems.

If the initial water hardness exceeds the value indicated in the table, a water softening system must be used. Excessive water softening (total hardness < 1.5 mmol/l) could lead to corrosion on contact with metal elements (pipes or boiler parts). Also keep the conductivity value within 600 µS/cm.

Check the outlet chloride concentration after resin regeneration.

It is forbidden to introduce acids into the flushing circuit.

It is forbidden to constantly or frequently top up the system, as this can damage the heat exchanger of the equipment.

WATER CONTENT AND WATER FLOW RATE SYSTEM

Heat pumps require systems that guarantee a constant fluid flow rate to the device, within minimum and maximum values and with sufficient volumes to avoid any imbalance in the cooling circuits and ensure the correct degree of comfort.

WATER CONTENT

A minimum volume of water in the system's primary circuit must be guaranteed for the appliance to operate correctly. The minimum volume is necessary to prevent the risk of ice formation during defrosting operations or continuous modulation of the compressor frequency.

It also provides the following advantages:

- less appliance wear;
- increase in system efficiency;
- improved stability and temperature precision.

The water flow rate shall be maintained constant during operation and shall comply with

Model	UM	004	006	008	010	012	014	016	12T	14T	16T
Minimum system water content ⁽¹⁾	l	25	25	25	25	40	40	40	40	40	40
Minimum water flow rate	m ³ /h	0.40	0.40	0.40	0.40	0.70	0.70	0.70	0.70	0.70	0.70
Maximum water flow rate	m ³ /h	2.10	2.10	2.10	2.10	3.00	3.00	3.00	3.00	3.00	3.00

(1) Excluding the volume of water inside the unit.

HEAT PUMPS

Floor-standing split heat pump

WIRING

INDOOR UNIT

For the electrical connection of the unit you need:

- 1 Connect the power to the outdoor unit
- 2 Connect the power to the indoor unit
- 3 Connect the connection between the outdoor and indoor unit

Refer to the product installation manual for more information.

Description	M31/ 04-10	M61/ 04-10	L31/ 04-10	L61/ 04-10	L61/ 12-16	L93/ 12-16
Electric power supply	220-240V 1N ~ 50Hz	220-240V 1N ~ 50Hz	220-240V 1N ~ 50Hz	220-240V 1N ~ 50Hz	220-240V 1N ~ 50Hz	380-415V 3N ~ 50Hz
Rated input	3095W	4095W	3095W	4095W	4095W	9095W
Rated current	13.5A	17.8A	13.5A	17.8A	17.8A	13.3A
Default electric heater power	3000W	4000W*	3000W	4000W*	4000W*	9000W**

* In single phase models, the back-up heater is set 4kW as default (factory setting). It is possible to change to either 2kW or 6kW, please refer to Installation manual for more information.

** In three phase models, the back-up heater is set 9kW as default (factory setting). It is possible to change to either 3kW or 6kW, please refer to Installation manual for more information.

INDOOR UNIT POWER CONNECTION

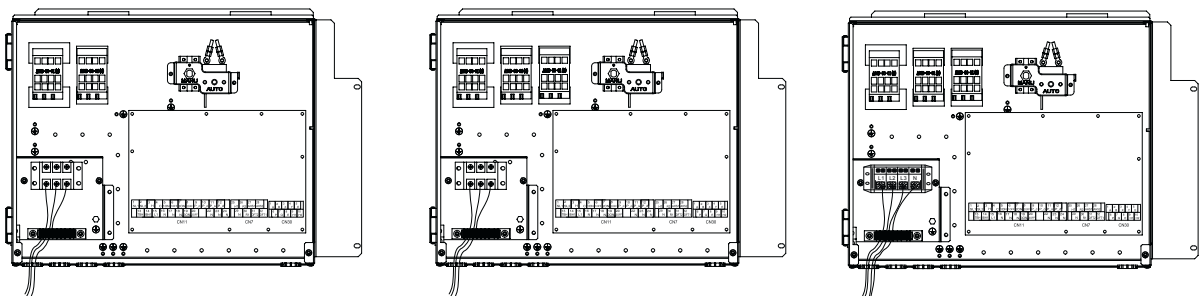
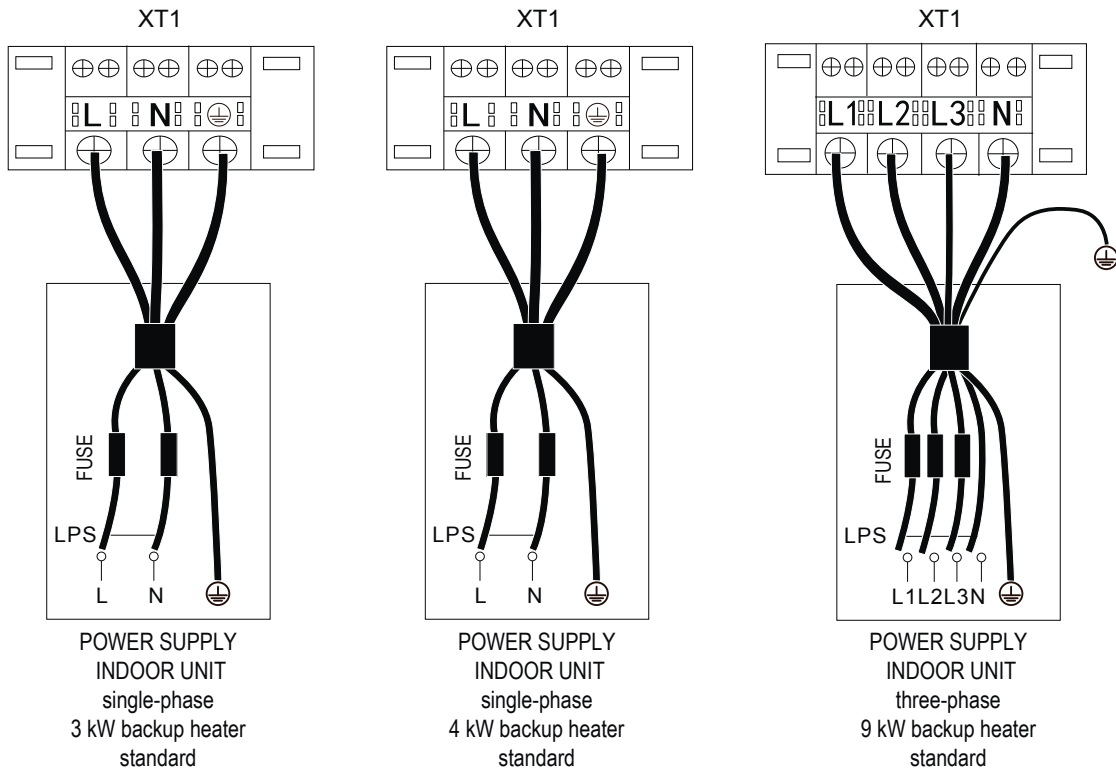

Description	3 kW - 1 PH	4 kW - 1 PH	9 kW - 3 PH
Wiring size mm ²	4	4	4

HEAT PUMPS

Floor-standing split heat pump

OUTDOOR UNIT

Safety device requirement:

- Select cable diameters (minimum value) individually for each unit based on tables 1 and 2, where the rated current in table 1 means MCA in table 2. If MCA exceeds 63A, the cable diameters must be selected in accordance with national wiring regulations.
- The maximum permissible voltage range variation between phases is 2%.
- Select a circuit breaker that has a contact separation at all poles of not less than 3 mm and allows complete disconnection, where MFA is used to select current circuit breakers and differential switches.

CABLE SIZING

Use the tables below when sizing the power cables and safety equipment:

Appliance rated current: (A)	Nominal cross-sectional area (mm ²)	
	Flexible cables	Fixed wiring cable
≤3	0.5 and 0.75	1 and 2.5
>3 and ≤6	0.75 and 1	1 and 2.5
>6 and ≤10	1 and 1.5	1 and 2.5
>10 and ≤16	1.5 and 2.5	1.5 and 4
>16 and ≤25	2.5 and 4	2.5 and 6
>25 and ≤32	4 and 6	4 and 10
>32 and ≤50	6 and 10	6 and 16
>50 and ≤63	10 and 16	10 and 25

System	Standard 4-16 kW single-phase and standard 12-16 kW three-phase										
	Outdoor unit				Power supply current			Compressor		Fan	
	Voltage (V)	Hz	Min. (V)	Max. (V)	MCA (A)	TOCA (A)	MFA (A)	MSC (A)	RLA (A)	kW	FLA (A)
4 kW	220-240	50	198	264	12	18	25	-	11.50	0.10	0.50
6 kW	220-240	50	198	264	14	18	25	-	13.50	0.10	0.50
8 kW	220-240	50	198	264	16	19	25	-	14.50	0.17	1.50
10 kW	220-240	50	198	264	17	19	25	-	15.50	0.17	1.50
12 kW	220-240	50	198	264	25	30	35	-	23.50	0.17	1.50
14 kW	220-240	50	198	264	26	30	35	-	24.50	0.17	1.50
16 kW	220-240	50	198	264	27	30	35	-	25.50	0.17	1.50
12 kW Three-phase	380-415	50	342	456	10	14	16	-	9.15	0.17	1.50
14 kW Three-phase	380-415	50	342	456	11	14	16	-	10.15	0.17	1.50
16 kW Three-phase	380-415	50	342	456	12	14	16	-	11.15	0.17	1.50

MCA: Maximum circuit amps (A)

TOCA: Total overcurrent amps (A)

MFA: Maximum fuse amps (A)

MSC: Max. Starting current (A)

RLA: In nominal cooling or heating test conditions, the amps at compressor input where MAX. Hz can operate with the rated load amps (A)

kW: Motor nominal power

FLA: Full load amps (A)

REMOVE THE ELECTRICAL PANEL COVER

	Standard 4-16 kW single-phase and standard 12-16 kW three-phase									
System	4 kW	6 kW	8 kW	10 kW	12 kW	14 kW	16 kW	12 kW Three-phase	14 kW Three-phase	16 kW Three-phase
Maximum overcurrent protection (MOP) (A)	18	18	19	19	30	30	30	14	14	14
Cable dimensions (mm ²)	4.0	4.0	4.0	4.0	6.0	6.0	6.0	2.5	2.5	2.5

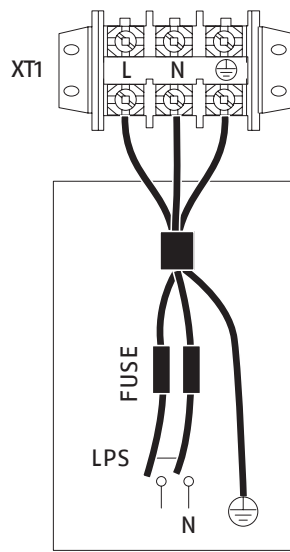
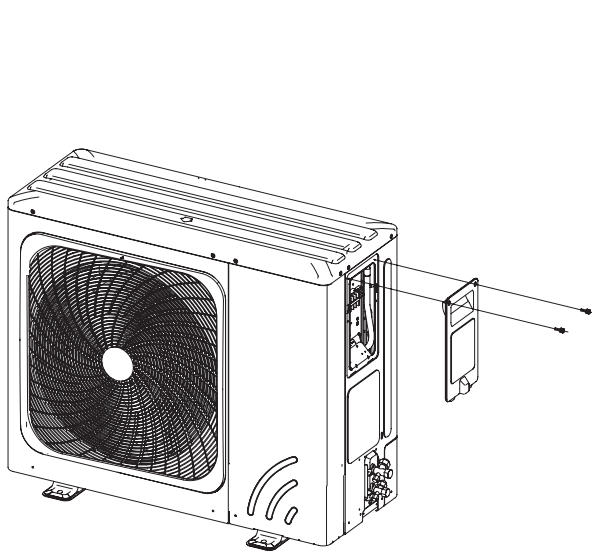

UNIT POWER SUPPLY
single-phase

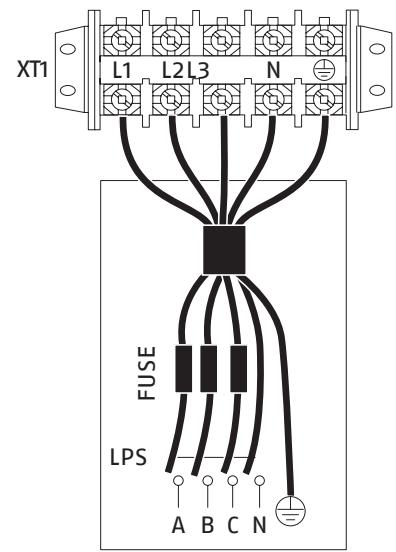

UNIT POWER SUPPLY
three-phase

HEAT PUMPS

Floor-standing split heat pump

CONTROL PANEL

GENERAL INFORMATION ABOUT BUTTONS AND FUNCTIONS

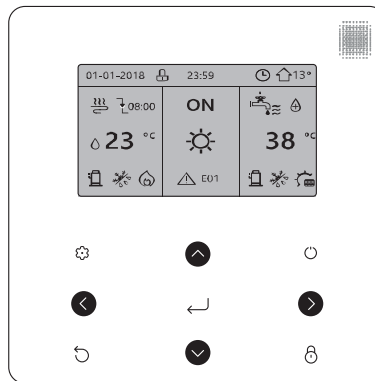

SYMBOL	DESCRIPTION
	Go to the menu structure (on the home page)
	Move the cursor on the display Move within the menu structure Adjust the settings
	Activate/ deactivate room heating /cooling operation or DHW mode Activate or deactivate functions in the menu structure
	Go back to the next higher level
	Press and hold to unlock/lock the controller Unlock/lock certain functions such as 'DHW temperature control'.
	Go to the next step when setting a programming in the menu structure; confirm a selection to access a submenu in the menu structure

The interface normally displays the water temperature in the DHW tank and enables all operations relating to instrument use to be carried out, particularly:

- setting summer/winter operating mode
- viewing and rearming alarms
- checking the status of resources (setpoints, temperatures, outdoor unit and backup heater operating hours)

MAIN ACCESSORIES

50 L INERTIAL TANK

Insulated 50-litre inertia tank designed to minimise heat pump on/off cycles when the system is running at almost full capacity. The inertia tank ensures, if required, the minimum water content in the system that the heat pump needs, depending on the installed capacity. This ensures the machine runs efficiently and optimally even in part load conditions.

- For hot and cold applications;
- It can be installed vertically or horizontally, inside or outside the building;
- It can be installed horizontally under the heat pump, thus minimising any space availability issues;
- Filling and emptying caps;
- Fitted with rubber elements to dampen the vibration generated by the heat pump.

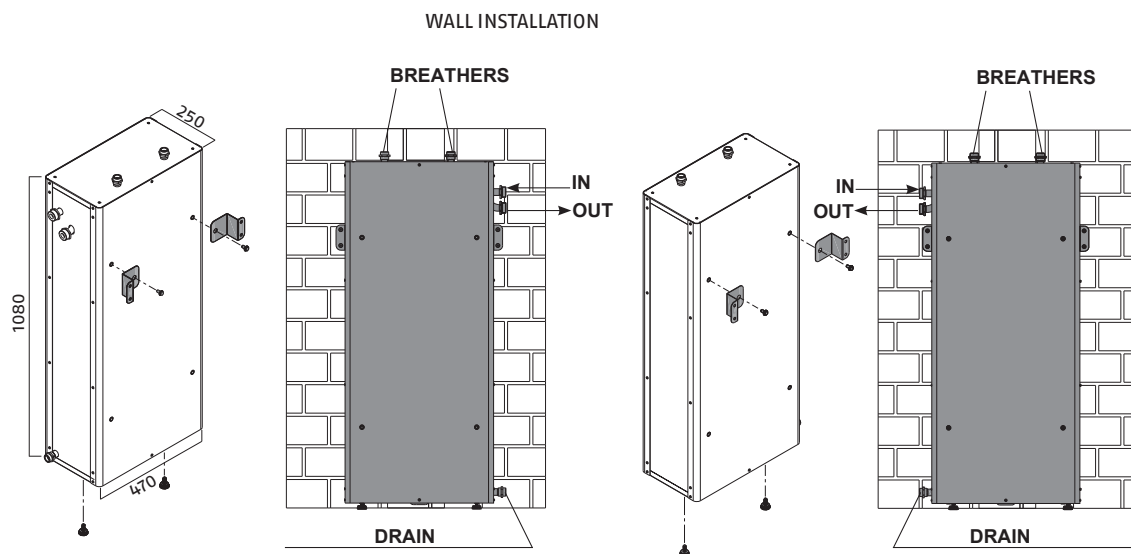

HEAT PUMPS

Floor-standing split heat pump

FLOOR INSTALLATION

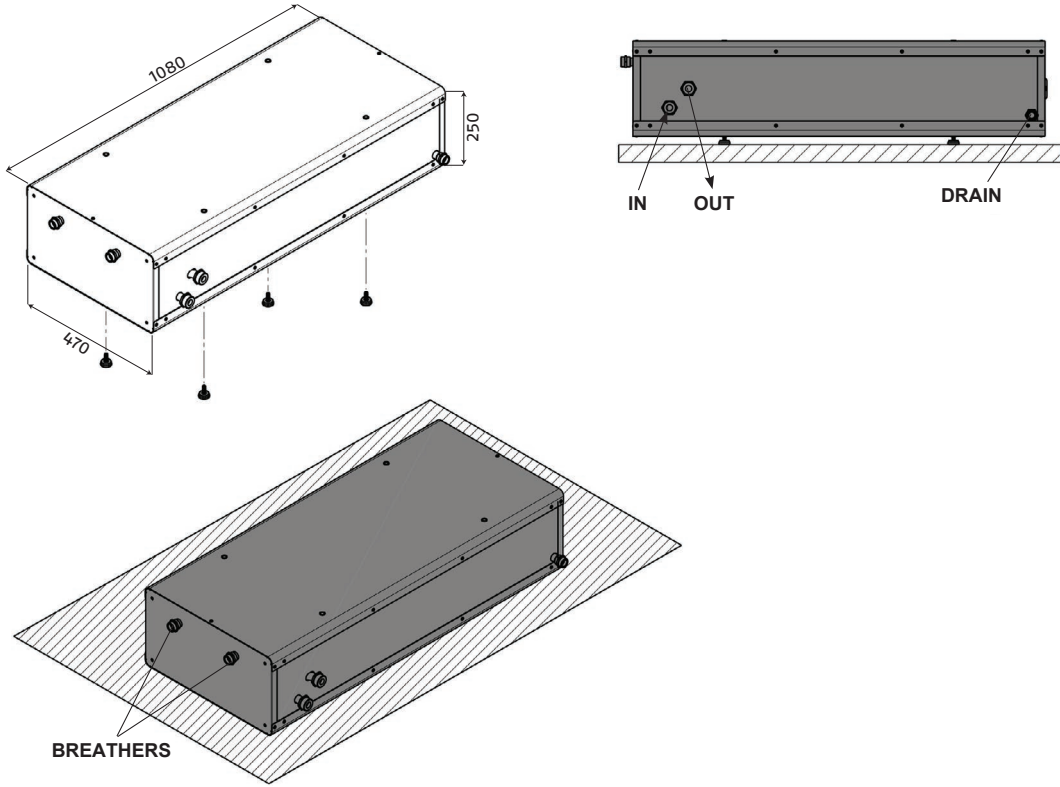

Specific tank conductivity 0.94 (W/K)

HEAD LOSS

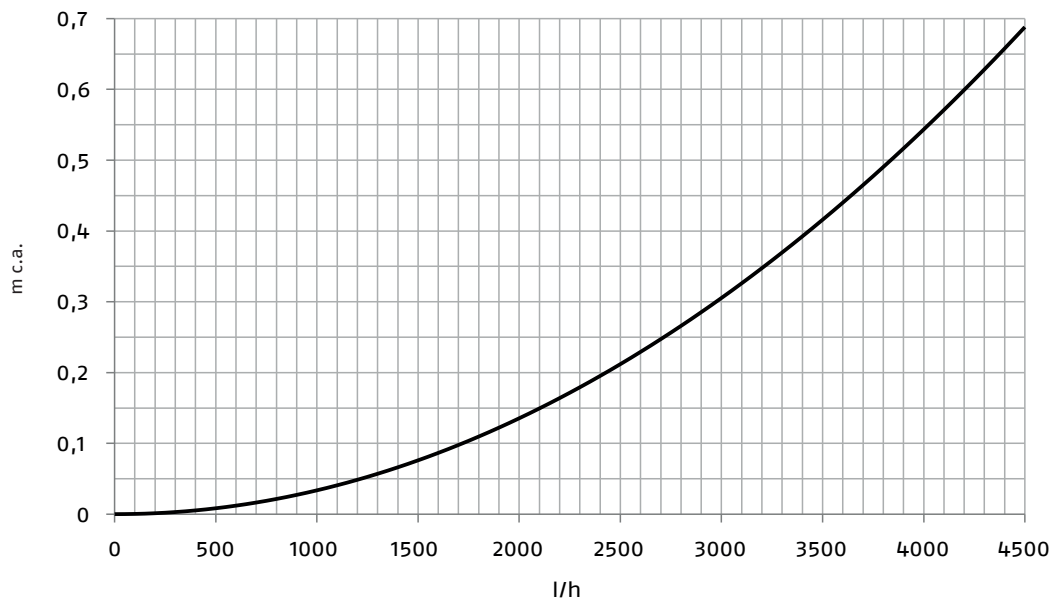

EXTERNAL DOMESTIC HOT WATER EXPANSION VESSEL

Kit expansion vessel for domestic hot water includes 8-litre expansion vessel, connection piping, safety valve and support to be installed on the back of the Indoor unit. The same kit is installable on all versions of the Indoor unit.

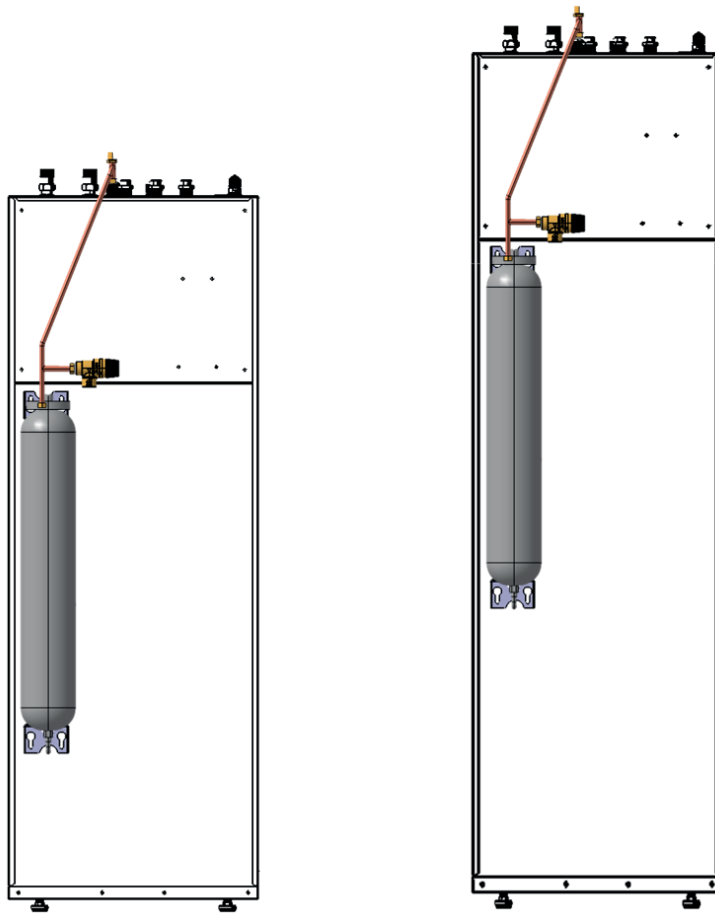

HEAT PUMPS

Floor-standing split heat pump

ZONE MANAGEMENT MODULE

Pre-assembled modules designed to allow quick and easy hydraulic connections, ensuring maximum installation flexibility of heat generators, solar thermal systems and heat pumps. Possibility of creating direct and/or mixed circuits, single or multiple, both in heating and cooling.

The use of high-quality components and the care in design guarantee high performance, while maintaining small dimensions and easy accessibility to the internal components. An integral part of the product is insulated, which thanks to the innovative structure of the insulating shell allows heat to be dissipated effectively, avoiding overheating of the electrical components in the winter and the formation of condensation when used for cooling in the summer. The modules are complete with thermometers, a 3-way mixing valve equipped with a motor (Module 25 Mix, and Module 32 Mix), gaskets, ball valves for the flow (complete with check valve) and for the return. Wide range of accessories to ensure maximum installation versatility.

Description	Electric power supply	Hydraulic connection		Recommended flow rate (m ³ /h)	Maximum temperature (°C)	Maximum pressure (bar)	Mixing valve (m ³ /h)
		System side	Heat pump side				
Module 25 DIR	Single phase	Ø 1" F	Ø 1" ½ M	2,6	100	10	-
Module 25 MIX	Single phase	Ø 1" F	Ø 1" ½ M	1,6	100	10	8,5
Module 32 DIR	Single phase	Ø 1" ¼ F	Ø 2" M	3,35	100	8	-
Module 32 MIX	Single phase	Ø 1" ¼ F	Ø 2" M	2,7	100	8	17

MODULE 25 DIR – 25 MIX

Hydraulic performance

The included Wilo Para 25–6 electronic circulator in class "A" complies with the ErP 2013 and ErP 2015 directives (EEI ≤0.20) and allows working at a fixed speed or at variable Δp to better meet the different system requirements.

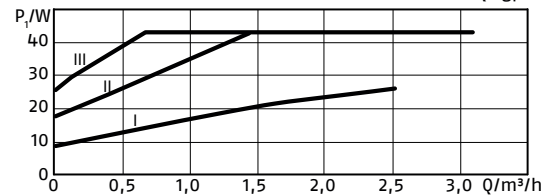
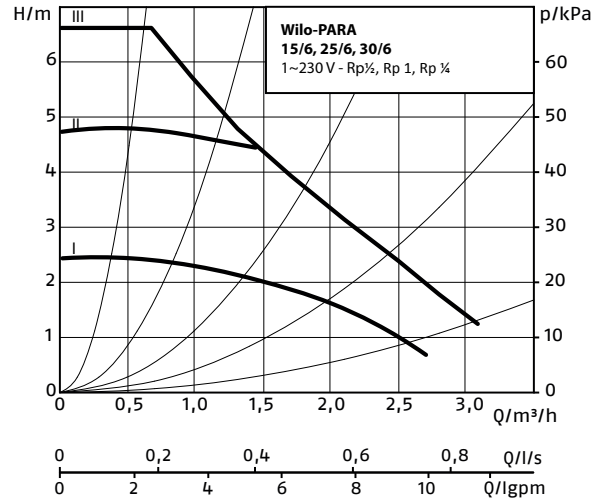
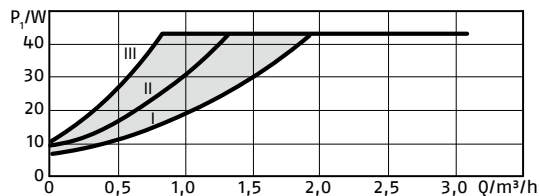
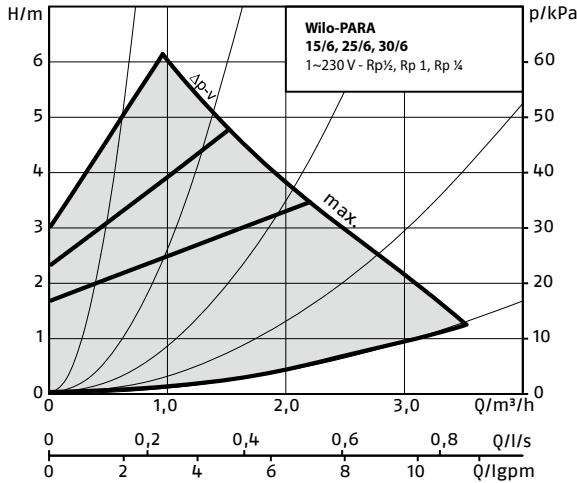

Module 25 Dir

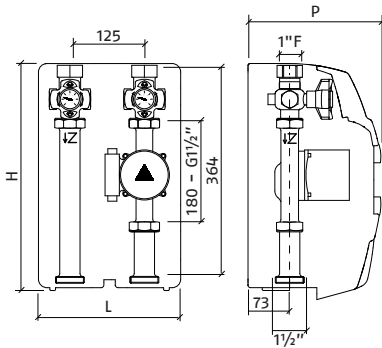

HYDRAULIC CONNECTIONS		MEASURES		
Central heating (CH) side (ø)	Generator side (ø)	H (mm)	L (mm)	P (mm)
1" F	1" 1/2 M	400	250	240
1" F	1" 1/2 M	400	250	240

COMPONENTS

- 2 - DN 25 V ball valve with OT 58 cap
- 1 - DN 25 h=90 mm Flow connection with cap
- 1 - DN 25 h=272 mm return connection with acetal resin check valve (POM)
- 1 - Red handle
- 1 - Blue handle
- 2 - Thermometers
- 5 - Viton/EPDM Gaskets
- 1 - Black EEP insulation (40 g/l)
- 1 - VegA RMXA 25-60 circulator

PRESSURE LOSSES

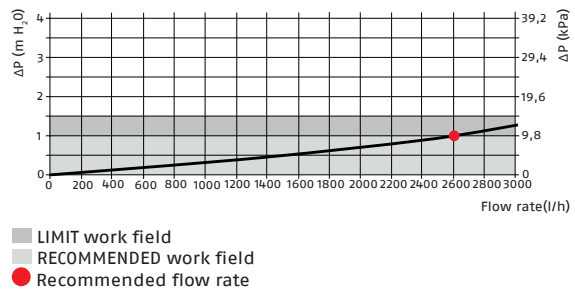

Module 25 Mix

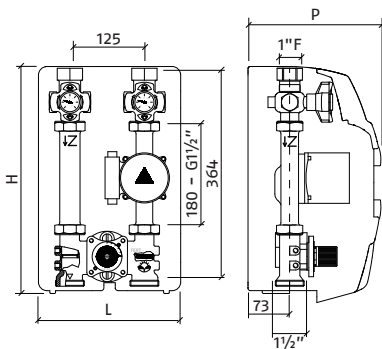

HYDRAULIC CONNECTIONS		MEASURES		
Central heating (CH) side (ø)	Generator side (ø)	H (mm)	L (mm)	P (mm)
1" F	1" 1/2 M	400	250	240
1" F	1" 1/2 M	400	250	240

COMPONENTS

- 1 - DN 25 3-way mixing valve with OT 58 caps
- 2 - DN 25 V ball valve with OT 58 cap 8
- 1 - DN 25 h=180 mm spacer connection with acetal resin check valve (POM)
- 1 - Red handle
- 1 - Blue handle
- 2 - Thermometers
- 6 - Viton/EPDM Gaskets
- 1 - Black EEP insulation (40 g/l)
- 1 - VegA RMXA 25-60 circulator

PRESSURE LOSSES

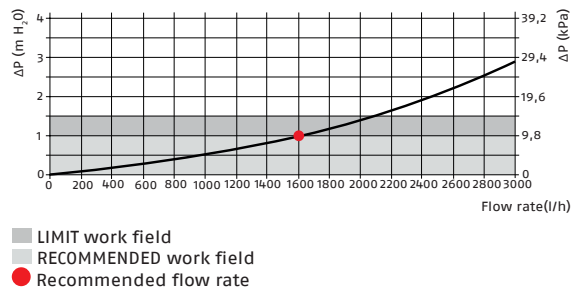

HEAT PUMPS

Floor-standing split heat pump

MODULE 32 DIR - 32 MIX

Hydraulic performance

The supplied class "A" electronic circulator complies with current European directives and allows working at constant Δp and variable Δp to better meet the different system requirements.

Δp -c (constant)

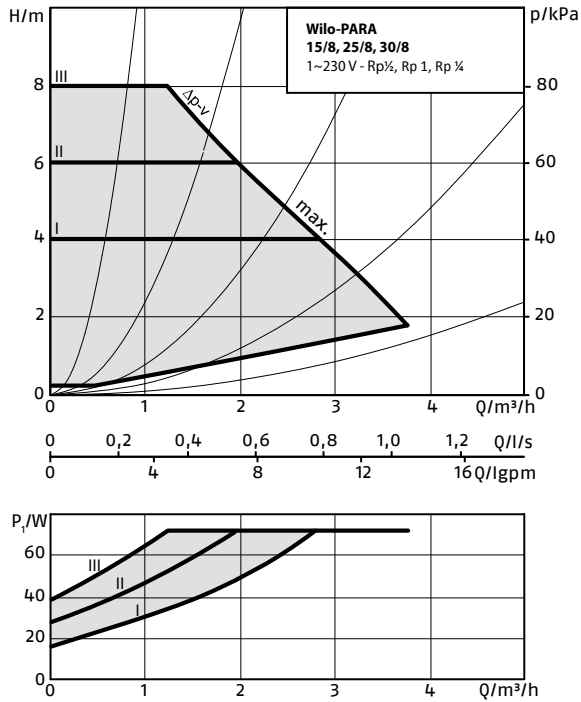

Δp -v (variable)

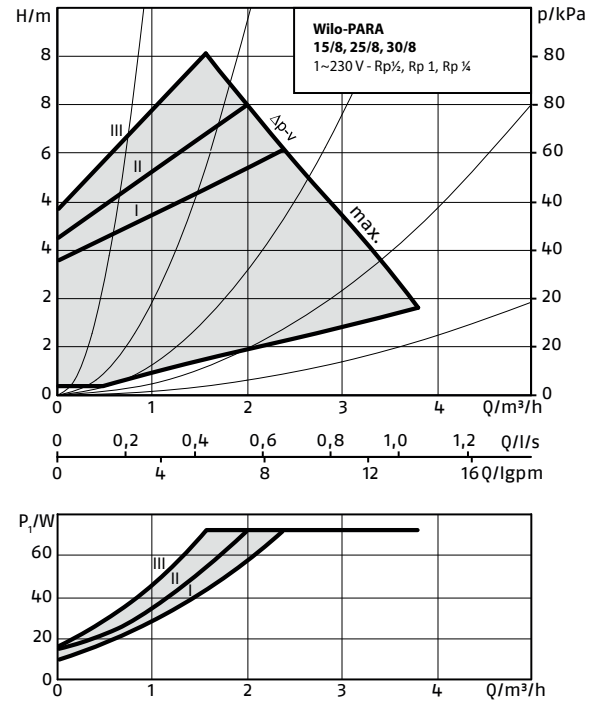

Module 32 Dir

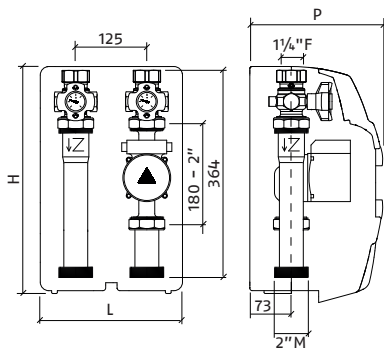

HYDRAULIC CONNECTIONS		MEASURES		
Central heating (CH) side (ø)	Generator side (ø)	H (mm)	L (mm)	P (mm)
1"¼ F	2" M	400	265	250
1"¼ F	2" M	400	265	250

COMPONENTS

- 2 - DN 32 V ball valve with OT58 cap
- 1 - DN 32 h=90 mm Flow connection with cap
- 1 - DN 32 h=272 mm return connection with acetal resin check valve (POM)
- 1 - Red handle
- 1 - Blue handle
- 2 - Thermometers
- 7 - Viton/EPDM Gaskets
- 1 - Black EEP insulation (40 g/l)
- 1 - A Class electronic circulator

PRESSURE LOSSES

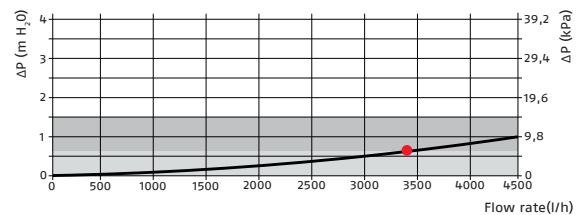

- LIMIT work field
- RECOMMENDED work field
- Recommended flow rate

Module 32 Mix

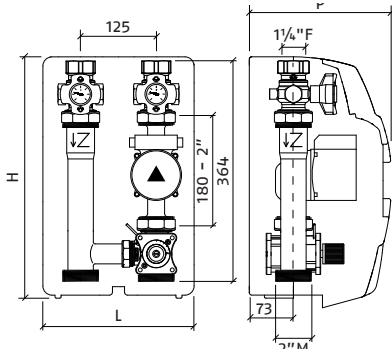

HYDRAULIC CONNECTIONS		MEASURES		
Central heating (CH) side (ø)	Generator side (ø)	H (mm)	L (mm)	P (mm)
1"1/4 F	2" M	400	265	250
1"1/4 F	2" M	400	265	250

COMPONENTS

- 1 - DN 32 3-way mixing valve with OT 58 caps
- 2 - DN 32 V ball valve with OT 58 cap
- 1 - DN 32 h=272 mm spacer connection with acetal resin check valve (POM)
- 1 - Red handle
- 1 - Blue handle
- 2 - Thermometers
- 8 - Viton/EPDM Gaskets
- 1 - Black EEP insulation (40 g/l)
- 1 - A Class electronic circulator

PRESSURE LOSSES

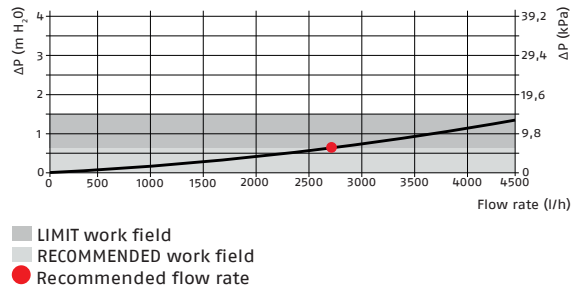

HEAT PUMPS

Floor-standing split heat pump

CONSTRUCTION DESCRIPTION FOR SPECIFICATIONS

Single-phase or three-phase split air-water heat pump with DC-inverter control and MITSUBISHI twin rotary compressor for all sizes to guarantee optimum dynamic balancing and reduce vibration, with continuous modulation from approx. 40% to 120%, designed to work with R32 refrigerant gas.

Given the wide operating range, it is ideal for every type of system, whether hybrid or monovalent. In heating mode in fact, it can supply water up to 65°C with an outdoor temperature from 7°C or 60°C with an outdoor temperature as low as -15°C, and in cooling mode water at 7°C with an outdoor temperature up to 43°C. It can also produce domestic hot water thanks to integrated cylinders, as it can deliver water at 55°C with an outdoor temperature of 43°C.

Top level performance. Up to A+++ for low temperatures and A++ for medium temperatures in average climate, according to EN 14825 (the energy class range is between A+++ and D), and A+ for domestic hot water in average climate, according to EN 16147 (the energy class range is between A+ and D). All the performance values are certified by HP Keymark.

Built in accordance with the European eco-design regulations, which define the requirements for the ERP (Energy Related Products) standard in order to improve energy efficiency.

CHARACTERISTICS

- DOMUS M provides an extremely high level of energy efficiency in both heating and cooling mode, thereby guaranteeing significant energy savings. The large, high-efficiency coils, together with the optimised circuits, ensure results that meet the European tax relief requisites. Efficiency levels in partial load conditions (seasonal energy efficiency) are among the best in this industrial sector.
- Comfort throughout the year: the ground-breaking technology of DOMUS M means boosted comfort levels for users in terms of both water temperature control and low noise operation. The required temperature is reached quickly and kept constant, without any fluctuations. DOMUS M offers optimised, personalised comfort levels both in winter and in summer.
- DOMUS M can work in cooling mode even with low outdoor temperatures (from -5°C, and up to 43°C). To ensure the maximum comfort for the user, the units work in heating mode with outdoor temperatures down to -25°C, whereas in summer they can produce hot water up to 55°C for DHW applications, with the an outdoor temperature as high as 43°C.
- Integrated 190-litre or 240-litre stainless steel hot water cylinder
- In the ambient comfort modes (both heating and cooling), weekly programming is a standard feature. In the DHW modes, weekly programming and an anti-legionella function - with thermal disinfection - are available as standard.
- Multiple system layouts possible. Thanks to the available accessories, the unit can manage one or two zones (one of them mixed).
- USB port available for updating the electronic board software.
- A dry contact input is available, dedicated to smart grid functions.
- Operation guaranteed with at least 40lt of water in the system.

OUTDOOR UNIT COMPONENTS

STRUCTURE

Cabinet made of sheet steel painted with neutral-coloured powders (RAL 7035) to enhance resistance to corrosion caused by atmospheric agents. All the panels are removable.

COMPRESSOR

The Twin rotary compressor protection shield for sound insulation further reduces sound levels. Advanced technology ensuring optimum energy efficiency and characterised by high output levels in peak conditions and optimised efficiency at low and medium compressor speeds.

The DOMUS M heat pump uses DC inverter technology that combines two electronic adjustment logics, pulse amplitude modulation (PAM) and pulse width modulation (PWM), to guarantee optimised compressor operation in all working conditions, minimise temperature fluctuation and ensure perfect comfort adjustment whilst at the same time considerably reducing energy consumption.

- PAM: modulation of the direct current pulse amplitude makes the compressor work in maximum load conditions (start-up and peak load) so as to increase the voltage in the case of a fixed frequency. The compressor works at high speed to quickly reach the required temperature.
- PWM: modulation of the direct current pulse width makes the compressor work in part load conditions, adapting the frequency in the case of a fixed voltage. The compressor speed is precisely adjusted and the system offers a high comfort level (no temperature fluctuations) in working conditions of outstanding efficiency.

The compressor frequency increases constantly until it reaches the maximum level. This ensures that there are no intensity peaks during the start-up phase, and also means a secure connection to the single-phase current supply even for high output systems. This compressor start logic makes "soft start" starter devices unnecessary, while also guaranteeing that the maximum output is available immediately.

EXTERNAL COIL

The external coil is made of copper pipes and hydrophilic aluminum fins. This solution makes it easier for the water to move towards the bottom of the heat exchanger, by means of gravity.

In particular, this innovation means:

- frost takes longer to form, so it does not build up so much on the coil;
- the defrosting phase is more efficient thanks to improved water runoff on the fins which boosts operation in heating mode.

Blue Coating treatment is applied as standard to improve the resistance of the coils to corrosive agents, and is recommended in all applications where there is a moderate risk of corrosion.

EXTERNAL FAN

Single DC brushless fan motor with variable speed for optimum air distribution and extremely low noise levels. Two different maximum noise levels can be set.

ELECTRONIC EXPANSION VALVE

The electronic expansion valve is a dual-flow electronic expansion device whose job is to optimise the volume of the refrigerant fluid in the circuit and therefore the overheating issue, preventing the fluid from returning to the compressor. This device further boosts the high efficiency and reliability of the system as it enables it to work even with very low condensation pressure values across the whole operating range.

SOLENOID VALVE

Given the wide operating range of the unit, the solenoid valve (fully managed by the unit itself) allows the compressor to work at optimum temperature levels at all times.

INDOOR UNIT COMPONENTS

HYDRONIC UNIT

The hydronic module is always installed and is supplied with a variable-speed circulation pump, flow switch, 3 bar safety valve, 8-litre expansion vessel, and inlet and outlet water temperature probes.

An electric backup heater as standard.

All the internal hydronic parts are insulated to reduce heat loss. The anti-freeze program contains special functions that use the heat pump and backup heater to protect the whole system from the risk of freezing. When the water flow temperature in the system falls to a certain value, the unit heats the water using both the heat pump, and the backup heater. The anti-freeze protection function is only deactivated when the temperature rises to a certain value.

PLATE EXCHANGER

Vertical plate heat exchanger in AISI 316 stainless steel.

CYLINDER

Integrated 190-litre or 240-litre stainless steel domestic hot water cylinder. Maximum pressure is 10 bar.

HEAT PUMPS

Floor-standing split heat pump

CONTROL PANEL

Control panel functions include:

- Full control and supervision of refrigerant circuit
- Management of compressor and fans modulation signal
- Fault signal
- Management of external coil defrosting
- Logic management of internal plate heat exchanger heat dissipation and anti-freeze
- Management of space heating functions, DHW production (with anti-legionella functions), and space cooling
- Primary circulator management
- Management of 3-way valve for DHW production
- External sensor management
- Management of backup electric heater

COMPLIANCE

The DOMUS M heat pumps comply with the following European Directives:

- EMC directive 2014/30/EU
- Low Voltage directive 2014/35/EU
- Pressure Equipment directive 2014/68/EU
- ErP Directive 2009/125/EC and Regulation (EU) 813/2013
- RoHS Directive 2011/65/EU
- F-Gas Regulation 2014/517/EU
- WEEE Directive 2012/19/EU.

RIELLO

RIELLO S.p.A.
37045 Legnago (VR) Italy
tel. +39 0442 630111



DOMUS M

www.riello.com



The company is constantly striving to perfect its entire production range, so the design and size characteristics, technical data, equipment and accessories may vary.



©2026 Carrier. All rights reserved.
All product and service trademarks mentioned in this document are the property of their respective owners.