

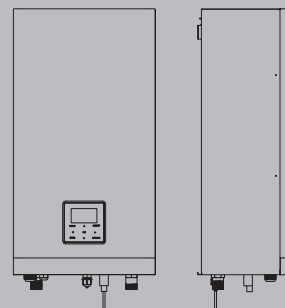

Family Sprint

Split air-water heat pump

Split heat pump with indoor wall-mounted unit for heating, cooling and DHW production
Wide range of powers available, from 4 to 16 kW single-phase and 12 to 16 kW three-phase
Indoor unit only 270 mm deep
High efficiency class: A+++ in heating (A7°C; W35°C)
Water temperature in heating up to 65°C





HEAT PUMPS

Split air-water heat pumps



Contents

Technical data	4
Description and dimensions	19
Appliance installation	20
Description of specifications	38

HEAT PUMPS

Split air-water heat pumps

Family Sprint

Family Sprint is a split heat pump system with an indoor wall unit for heating, cooling and hot water production if paired with an external storage tank. The system is made up of an outdoor unit with R32 gas connected via refrigerant piping to the indoor wall-mounted unit.

The compact, quiet outdoor unit includes a Twin Rotary DC inverter compressor, an electronic expansion valve, fans with brushless motor, and a finned coil optimised for heat pump operation even at outdoor air temperatures down to -25°C.

The indoor unit, only 270 mm deep, is available in two versions: without a backup heating element or with a backup heating element. In single-phase units, the backup heating element, where present, is 3 kW power, while in three-phase units, where present, it is 9 kW.

The system control panel, on board the indoor unit, features a large backlit display with user-friendly icons and a multi-language menu.

Family Sprint heat pumps are equipped with Silent Mode on two levels, which reduces the sound pressure to 39 db(A) (sound pressure of 4 kW size, in Silent Mode 2).

TECHNICAL DATA 4M ÷ 16M

DESCRIPTION	U.M.	4M	6M	8M	10M	12M	14M	16M
COMBINATION								
Indoor unit		SPRINT WH S	SPRINT WH S	SPRINT WH M	SPRINT WH M	SPRINT WH L	SPRINT WH L	SPRINT WH L
Outdoor unit		HP EXTERNAL UNIT 004	HP EXTERNAL UNIT 006	HP EXTERNAL UNIT 008	HP EXTERNAL UNIT 010	HP EXTERNAL UNIT 012	HP EXTERNAL UNIT 014	HP EXTERNAL UNIT 016
PERFORMANCE DATA IN HEATING								
Performance in heating (A7°C; W35°C)								
Nominal capacity	kW	4.25	6.20	8.30	10.00	12.10	14.50	16.00
Power input	kW	0.82	1.24	1.60	2.00	2.44	3.09	3.56
COP		5.20	5.00	5.20	5.00	4.95	4.70	4.50
SCOP		4,85	4,95	5,21	5,19	4,81	4,72	4,62
Seasonal energy efficiency	%	191	195	205	205	189	186	182
Energy class		A+++	A+++	A+++	A+++	A+++	A+++	A+++
Performance in heating (A7°C; W45°C)								
Nominal capacity	kW	4.35	6.35	8.20	10.00	12.30	14.20	16.00
Power input	kW	1.14	1.69	2.08	2.63	3.24	3.89	4.44
COP		3.80	3.75	3.95	3.80	3.80	3.65	3.60
Performance in heating (A7°C; W55°C)								
Nominal capacity	kW	4.40	6.00	7.50	9.50	12.00	13.80	16.00
Power input	kW	1.49	2.00	2.36	3.06	3.87	4.60	5.52
COP		2.95	3.00	3.18	3.10	3.10	3.00	2.90
SCOP		3,31	3,52	3,37	3,47	3,45	3,47	3,41
Seasonal energy efficiency	%	130	138	132	137	135	136	133
Energy class		A++	A++	A++	A++	A++	A++	A++
PERFORMANCE DATA IN COOLING								
Performance in cooling (A35°C; W7°C)								
Nominal capacity	kW	4.70	7.00	7.40	8.20	11.60	12.70	14.00
Power input	kW	1.36	2.33	2.19	2.48	4.22	4.98	5.71
EER		3.45	3.00	3.38	3.30	2.75	2.55	2.45
SEER		4.99	5.34	5.83	5.98	4.89	4.86	4.69
Seasonal energy efficiency	%	196	210	229	235	192	191	184
Performance in cooling (A35°C; W18°C)								
Nominal capacity	kW	4.50	6.55	8.40	10.00	12.00	13.50	14.20
Power input	kW	0.81	1.34	1.66	2.08	3.00	3.74	3.93
EER		5.55	4.90	5.05	4.80	4.00	3.61	3.61
ELECTRICAL SPECIFICATIONS								
Electric power supply	V/ph/Hz	230/1/50	230/1/50	230/1/50	230/1/50	230/1/50	230/1/50	230/1/50
Total maximum input power	(1) kW	2.20	2.60	3.30	3.60	5.40	5.70	6.10
Total maximum input current	(2) A	12.00	14.00	16.00	17.00	25.00	26.00	27.00

	DESCRIPTION	U.M.	4M	6M	8M	10M	12M	14M	16M
COMPRESSOR									
	Compressor	Type/ brand	Twin Rotary/Mitsubishi						
	Adjustment	Type	Inverter modulating						
	Minimum capacity control	%	55	44	40	38	46	41	40
	Refrigerant	Type	R32	R32	R32	R32	R32	R32	R32
	GWP	CO2 equiv. In t/kg	675	675	675	675	675	675	675
	Refrigerant load	kg	1.50	1.50	1.65	1.65	1.84	1.84	1.84
	Control box load	CO2 equiv. In t	1.01	1.01	1.11	1.11	1.24	1.24	1.24
	Number of circuits	no.	1	1	1	1	1	1	1
	Hermetically sealed control box (EU reg. 517_2014)	yes/no	no	no	no	no	no	no	no
FAN									
	Fan	Type	Axial	Axial	Axial	Axial	Axial	Axial	Axial
	Quantity	no.	1	1	1	1	1	1	1
	Maximum air flow rate	m ³ /h	2770	2770	4030	4030	4060	4060	4650
HEAT EXCHANGER (SOURCE SIDE)									
	Heat exchanger (source side)	Type	Copper pipes, fins in hydrophilic aluminium with anti-corrosion treatment						
HYDRONIC MODULE									
	Circulation pump	Type/ adjust- ment	Variable speed centrifuge						
	Nominal flow rate	m ³ /h	0.73	1.07	1.43	1.72	2.09	2.50	2.76
	Available head at nominal flow rate	Kpa	83	85	82	69	64	51	41
	Circulator maximum power input	W	90	90	90	90	90	90	90
	Circulator minimum power input	W	5	5	5	5	5	5	5
	Safety valve calibration pressure	bar	3	3	3	3	3	3	3
	Expansion vessel volume	l	8	8	8	8	8	8	8
HEAT EXCHANGER (SYSTEM SIDE)									
	Heat exchanger (system side)	Type	With plates	With plates	With plates	With plates	With plates	With plates	With plates
	Water content	l	5	5	5	5	5	5	5
SOUND DATA									
	Outdoor unit sound power level	(3) dB(A)	56	58	59	60	64	65	68
	Sound pressure at 1m outdoor unit	(4) dB(A)	44	45	46	49	50	51	54
	Indoor unit sound power level	(3) dB(A)	38	38	42	42	43	43	43
	Sound pressure at 1m indoor unit	(4) dB(A)	28	28	30	30	32	32	32
WEIGHT									
	Net weight outdoor unit	kg	58	58	75	75	111	111	111
	Net weight indoor unit	kg	37	37	37	37	51	51	51

The performance values comply with Standards UNI EN 14511 and UNI EN 14825.

- (1) Power input from outdoor unit at max operating conditions and nominal power supply voltage (for total system input add the power of the indoor units, with or without backup heating elements, stated in the electrical wiring section).
- (2) Maximum unit operating current with the nominal power supply voltage.
- (3) Sound emission values declared, in accordance with standard EN 12102-1.
- (4) Measured in a semi-anechoic chamber, at a distance of 1m from the front of the unit and at a height from the floor equal to (1+H)/2, where H is the height of the unit expressed in metres (in accordance with standard EN 12102-1).

 The data in the grey boxes is to be used for the telematic mailing to ENEA for tax relief purposes.

 The data in the grey boxes is to be used for the registration of the control box in the F-GAS databank.

HEAT PUMPS

Split air-water heat pumps

TECHNICAL DATA 12T ÷ 16T

	DESCRIPTION	U.M.	12T	14T	16T
COMBINATION					
	Indoor unit		SPRINT WH L	SPRINT WH L	SPRINT WH L
	Outdoor unit		HP EXTERNAL UNIT 012T	HP EXTERNAL UNIT 014T	HP EXTERNAL UNIT 016T
PERFORMANCE DATA IN HEATING					
Performance in heating (A7°C; W35°C)					
	Nominal capacity	kW	12.10	14.50	16.00
	Power input	kW	2.44	3.09	3.56
	COP		4.95	4.70	4.50
	SCOP		4,81	4,72	4,62
	Seasonal energy efficiency	%	189	186	182
	Energy class		A+++	A+++	A+++
Performance in heating (A7°C; W45°C)					
	Nominal capacity	kW	12.30	14.20	16.00
	Power input	kW	3.24	3.89	4.44
	COP		3.80	3.65	3.60
Performance in heating (A7°C; W55°C)					
	Nominal capacity	kW	12.00	13.80	16.00
	Power input	kW	3.87	4.60	5.52
	COP		3.10	3.00	2.90
	SCOP		3,45	3,47	3,41
	Seasonal energy efficiency	%	135	136	133
	Energy class		A++	A++	A++
PERFORMANCE DATA IN COOLING					
Performance in cooling (A35°C; W7°C)					
	Nominal capacity	kW	11.60	12.70	14.00
	Power input	kW	4.22	4.98	5.71
	EER		2.75	2.55	2.45
	SEER		4.89	4.86	4.69
	Seasonal energy efficiency	%	192	191	184
Performance in cooling (A35°C; W18°C)					
	Nominal capacity	kW	12.00	13.50	14.20
	Power input	kW	3.00	3.74	3.93
	EER		4.00	3.61	3.61
ELECTRICAL SPECIFICATIONS					
	Electric power supply	V/ph/Hz	400/3/50	400/3/50	400/3/50
	Total maximum input power	(1) kW	5.40	5.70	6.10
	Total maximum input current	(2) A	10.00	11.00	12.00
COMPRESSOR					
	Compressor	Type/ brand	Twin Rotary/Mitsubishi		
	Adjustment	Type	Inverter modulating		
	Minimum capacity control	%	46	41	40
	Refrigerant	Type	R32	R32	R32
	GWP	CO2 equiv. ln t/kg	675	675	675
	Refrigerant load	kg	1.84	1.84	1.84
	Control box load	CO2 equiv. ln t	1.24	1.24	1.24
	Number of circuits	no.	1	1	1
	Hermetically sealed control box (EU reg. 517_2014)	yes/no	no	no	no
FAN					
	Fan	Type	Axial	Axial	Axial
	Quantity	no.	1	1	1
	Maximum air flow rate	m ³ /h	4060	4060	4650
HEAT EXCHANGER (SOURCE SIDE)					
	Heat exchanger (source side)	Type	Copper pipes, fins in hydrophilic aluminium with anti-corrosion treatment		

DESCRIPTION	U.M.	12T	14T	16T
HYDRONIC MODULE				
Circulation pump	Type/ adjust- ment	Variable speed centrifuge		
Nominal flow rate	m ³ /h	2.09	2.50	2.76
Available head at nominal flow rate	Kpa	64	51	41
Circulator maximum power input	W	90	90	90
Circulator minimum power input	W	5	5	5
Safety valve calibration pressure	bar	3	3	3
Expansion vessel volume	l	8	8	8
HEAT EXCHANGER (SYSTEM SIDE)				
Heat exchanger (system side)	Type	With plates	With plates	With plates
Water content	l	5	5	5
SOUND DATA				
Outdoor unit sound power level	(3) dB(A)	64	65	68
Sound pressure at 1m outdoor unit	(4) dB(A)	50	51	55
Indoor unit sound power level	(3) dB(A)	43	43	43
Sound pressure at 1m indoor unit	(4) dB(A)	32	32	32
WEIGHT				
Net weight outdoor unit	kg	126	126	126
Net weight indoor unit	kg	51	51	51

The performance values comply with Standards UNI EN 14511 and UNI EN 14825.

- (1) Power input from outdoor unit at max operating conditions and nominal power supply voltage (for total system input add the power of the indoor units, with or without backup heating elements, stated in the electrical wiring section).
- (2) Maximum unit operating current with the nominal power supply voltage.
- (3) Sound emission values declared, in accordance with standard EN 12102-1.
- (4) Measured in a semi-anechoic chamber, at a distance of 1m from the front of the unit and at a height from the floor equal to (1+H)/2, where H is the height of the unit expressed in metres (in accordance with standard EN 12102-1).

The data in the grey boxes is to be used for the telematic mailing to ENEA for tax relief purposes.

The data in the grey boxes is to be used for the registration of the control box in the F-GAS databank.

HEAT PUMPS

Split air-water heat pumps

ENERGY DATA 4M – 16M

DESCRIPTION	U.M.	4M	6M	8M	10M	12M	14M	16M	
COMBINATION									
Indoor unit		SPRINT WH S	SPRINT WH S	SPRINT WH M	SPRINT WH M	SPRINT WH L	SPRINT WH L	SPRINT WH L	
Outdoor unit		HP EXTERNAL UNIT 004	HP EXTERNAL UNIT 006	HP EXTERNAL UNIT 008	HP EXTERNAL UNIT 010	HP EXTERNAL UNIT 012	HP EXTERNAL UNIT 014	HP EXTERNAL UNIT 016	
Temperate zone – Low temperature (30/35°C) EU reg. 811_2013									
Seasonal energy efficiency	%	191	195	205	205	189	186	182	
SCOP		4,85	4,95	5,21	5,19	4,81	4,72	4,62	
Prated	kW	5,52	6,82	8,12	9,17	12,00	13,73	15,21	
Annual energy consumption	kWh/ year	2351	2845	3218	3644	5152	6012	6804	
Energy class		A+++	A+++	A+++	A+++	A+++	A+++	A+++	
Outdoor unit sound power level	dB(A)	56	58	59	60	64	65	68	
Indoor unit sound power level	dB(A)	38	38	42	42	43	43	43	
Temperate zone – Medium temperature (47/55°C) EU reg. 811_2013									
Seasonal energy efficiency	%	130	138	132	137	135	136	133	
SCOP		3,31	3,52	3,37	3,47	3,45	3,47	3,41	
Prated	kW	4,40	5,70	6,60	7,67	11,58	12,08	13,02	
Annual energy consumption	kWh/ year	2744	3345	4056	4539	6927	7202	7895	
Energy class		A++	A++	A++	A++	A++	A++	A++	

The performance values comply with Standards UNI EN 14511 and UNI EN 14825.

ENERGY DATA 012T – 016T

	DESCRIPTION	U.M.	12T	14T	16T
COMBINATION					
	Indoor unit		SPRINT WH L	SPRINT WH L	SPRINT WH L
	Outdoor unit		HP EXTERNAL UNIT 012T	HP EXTERNAL UNIT 014T	HP EXTERNAL UNIT 016T
Temperate zone – Low temperature (30/35°C) EU reg. 811_2013					
	Seasonal energy efficiency	%	189	186	182
	SCOP		4,81	4,72	4,62
	Prated	kW	12,00	13,73	15,21
	Annual energy consumption	kWh/ year	5153	6013	6805
	Energy class		A+++	A+++	A+++
	Outdoor unit sound power level	dB(A)	64	65	68
	Indoor unit sound power level	dB(A)	43	43	43
Temperate zone – Medium temperature (47/55°C) EU reg. 811_2013					
	Seasonal energy efficiency	%	135	136	133
	SCOP		3,45	3,47	3,41
	Prated	kW	11,58	12,08	13,02
	Annual energy consumption	kWh/ year	6928	7203	7896
	Energy class		A++	A++	A++

The performance values comply with Standards UNI EN 14511 and UNI EN 14825.

HEAT PUMPS

Split air-water heat pumps

UNI 11300 PART 3 AND 4: PERFORMANCE AS PER UNI EN 14511 AND UNI EN 14825 – 4M TO 16M

HP EXTERNAL UNIT 004 – SPRINT WH S						
HEATING						
Performance with full load						
Delivery temperature	35°C		45°C		55°C	
	Nominal capacity (kW)	COP	Nominal capacity (kW)	COP	Nominal capacity (kW)	COP
Outdoor temperature						
-7	4.70	3.10	4.30	2.35	4.00	1.95
2	4.40	4.00	5.10	3.00	5.10	2.45
7	4.25	5.20	4.35	3.80	4.40	2.95
12	5.26	5.61	5.60	4.22	4.98	3.38
15	5.14	5.84	5.67	4.37	4.96	3.53
20	5.09	6.21	5.63	4.88	4.89	3.84
35	5.54	7.89	5.70	6.47	5.14	4.92
Performance with part load						
Tbival (-7°C)	A	B	C	D		
Outdoor temperature (°C)	-7	2	7	12		
PLR - Climate load factor	0.88	0.54	0.35	0.15		
DC - Output with full load	4.70	4.40	4.25	5.26		
COP with full load	3.10	4.00	5.20	5.61		
COP with part load	3,12	4,12	4,50	4,04		
CR - Load factor	1,00	0,68	0,45	0,16		
f COP - Corrective factor	1,01	1,03	0,87	0,72		

The performance values comply with Standards UNI EN 14511 and UNI EN 14825.

The performance values with a part load refer to a water delivery temperature of 35°C.

COOLING				
EER	Load factor	Outdoor temperature (°C)	EER	Nominal capacity (kW)
EER1	100%	35	3.45	4.70
EER2	75%	30	4.76	3.53
EER3	50%	25	5.72	2.35
EER4	25%	20	5.72	1.18

Performance in accordance with UNI EN 14825.

HP EXTERNAL UNIT 006 – SPRINT WH S						
HEATING						
Performance with full load						
Delivery temperature	35°C		45°C		55°C	
	Nominal capacity (kW)	COP	Nominal capacity (kW)	COP	Nominal capacity (kW)	COP
Outdoor temperature						
-7	6.00	3.00	5.40	2.40	5.15	2.00
2	5.50	3.90	5.80	3.00	5.65	2.45
7	6.20	5.00	6.35	3.75	6.00	3.00
12	6.51	5.38	6.83	4.09	6.12	3.27
15	6.48	5.57	6.98	4.32	6.15	3.42
20	6.27	6.28	6.82	4.62	6.03	3.76
35	6.46	8.87	6.55	5.79	6.02	4.75
Performance with part load						
Tbival (-7°C)	A	B	C	D		
Outdoor temperature (°C)	-7	2	7	12		
PLR - Climate load factor	0.88	0.54	0.35	0.15		
DC - Output with full load	6.00	5.50	6.20	6.51		
COP with full load	3.00	3.90	5.00	5.38		
COP with part load	3,03	4,18	4,86	4,09		
CR - Load factor	1,00	0,67	0,39	0,16		
f COP - Corrective factor	1,01	1,07	0,97	0,76		

The performance values comply with Standards UNI EN 14511 and UNI EN 14825.

The performance values with a part load refer to a water delivery temperature of 35°C.

COOLING				
EER	Load factor	Outdoor temperature (°C)	EER	Nominal capacity (kW)
EER1	100%	35	3.00	7.00
EER2	75%	30	4.00	5.25
EER3	50%	25	6.45	3.50
EER4	25%	20	7.73	1.75

Performance in accordance with UNI EN 14825.

HP EXTERNAL UNIT 008 – SPRINT WH M**HEATING****Performance with full load**

Delivery temperature	35°C		45°C		55°C	
	Nominal capacity (kW)	COP	Nominal capacity (kW)	COP	Nominal capacity (kW)	COP
Outdoor temperature						
-7	7.00	3.20	6.60	2.55	6.15	2.05
2	7.10	4.10	7.40	3.25	7.10	2.60
7	8.30	5.20	8.20	3.95	7.50	3.18
12	8.03	5.99	8.06	4.26	7.26	3.54
15	8.11	6.37	8.15	4.55	7.33	3.68
20	8.37	7.53	8.36	5.25	7.47	4.14
35	7.89	8.74	8.83	6.77	7.48	5.03

Performance with part load

Tbival (-7°C)	A	B	C	D		
Outdoor temperature (°C)	-7	2	7	12		
PLR – Climate load factor	0.88	0.54	0.35	0.15		
DC – Output with full load	7.00	7.10	8.30	8.03		
COP with full load	3.20	4.10	5.20	5.99		
COP with part load	3,28	4,39	5,00	4,37		
CR – Load factor	1,00	0,62	0,34	0,15		
f COP – Corrective factor	1,03	1,07	0,96	0,73		

The performance values comply with Standards UNI EN 14511 and UNI EN 14825.
The performance values with a part load refer to a water delivery temperature of 35°C.

COOLING

EER	Load factor	Outdoor temperature (°C)	EER	Nominal capacity (kW)
EER1	100%	35	3.38	7.40
EER2	75%	30	4.71	5.55
EER3	50%	25	6.65	3.70
EER4	25%	20	8.55	1.85

Performance in accordance with UNI EN 14825.

HP EXTERNAL UNIT 010 – SPRINT WH M**HEATING****Performance with full load**

Delivery temperature	35°C		45°C		55°C	
	Nominal capacity (kW)	COP	Nominal capacity (kW)	COP	Nominal capacity (kW)	COP
Outdoor temperature						
-7	8.00	3.05	7.35	2.55	6.85	2.00
2	8.20	4.00	7.85	3.20	8.10	2.56
7	10.00	5.00	10.00	3.80	9.50	3.10
12	9.03	5.77	9.11	4.06	8.50	3.41
15	9.13	6.22	9.22	4.38	8.60	3.67
20	9.58	7.14	9.46	5.08	8.73	4.05
35	8.59	9.01	9.81	6.84	8.63	5.29

Performance with part load

Tbival (-7°C)	A	B	C	D		
Outdoor temperature (°C)	-7	2	7	12		
PLR – Climate load factor	0.88	0.54	0.35	0.15		
DC – Output with full load	8.00	8.20	10.00	9.03		
COP with full load	3.05	4.00	5.00	5.77		
COP with part load	3,16	4,32	5,19	4,55		
CR – Load factor	1,00	0,60	0,32	0,15		
f COP – Corrective factor	1,04	1,08	1,04	0,79		

The performance values comply with Standards UNI EN 14511 and UNI EN 14825.
The performance values with a part load refer to a water delivery temperature of 35°C.

COOLING

EER	Load factor	Outdoor temperature (°C)	EER	Nominal capacity (kW)
EER1	100%	35	3.30	8.20
EER2	75%	30	4.47	6.15
EER3	50%	25	7.02	4.10
EER4	25%	20	9.54	2.05

Performance in accordance with UNI EN 14825.

HEAT PUMPS

Split air-water heat pumps

HP EXTERNAL UNIT 012 – SPRINT WH L

HEATING						
Performance with full load						
Delivery temperature	35°C		45°C		55°C	
	Nominal capacity (kW)	COP	Nominal capacity (kW)	COP	Nominal capacity (kW)	COP
Outdoor temperature						
-7	10.00	3.00	10.20	2.40	9.80	2.05
2	9.20	3.90	10.60	3.00	11.30	2.50
7	12.10	4.95	12.30	3.80	12.00	3.10
12	10.98	5.75	11.10	4.26	9.53	3.17
15	11.00	5.97	11.20	4.52	9.12	3.20
20	10.77	7.18	11.19	5.16	9.00	3.61
35	11.55	8.78	11.45	6.17	10.00	4.86
Performance with part load						
Tbival (-7°C)	A	B	C	D		
Outdoor temperature (°C)	-7	2	7	12		
PLR - Climate load factor	0.88	0.54	0.35	0.15		
DC - Output with full load	10.00	9.20	12.10	10.98		
COP with full load	3.00	3.90	4.95	5.75		
COP with part load	2,82	4,01	4,85	4,14		
CR - Load factor	1,00	0,70	0,35	0,16		
f COP - Corrective factor	1,00	1,03	0,98	0,72		

The performance values comply with Standards UNI EN 14511 and UNI EN 14825.
The performance values with a part load refer to a water delivery temperature of 35°C.

COOLING

EER	Load factor	Outdoor temperature (°C)	EER	Nominal capacity (kW)
EER1	100%	35	2.75	11.60
EER2	75%	30	3.93	8.70
EER3	50%	25	5.73	5.80
EER4	25%	20	6.75	2.90

Performance in accordance with UNI EN 14825.

HP EXTERNAL UNIT 014 – SPRINT WH L

HEATING						
Performance with full load						
Delivery temperature	35°C		45°C		55°C	
	Nominal capacity (kW)	COP	Nominal capacity (kW)	COP	Nominal capacity (kW)	COP
Outdoor temperature						
-7	12.00	2.85	11.70	2.35	11.00	2.05
2	11.00	3.60	11.50	2.85	12.40	2.45
7	14.50	4.70	14.20	3.65	13.80	3.00
12	11.50	5.46	11.69	4.12	10.28	3.32
15	11.62	5.67	11.89	4.25	9.84	3.41
20	11.09	6.27	11.47	4.87	9.53	3.74
35	11.77	8.63	11.99	6.10	10.09	4.93
Performance with part load						
Tbival (-7°C)	A	B	C	D		
Outdoor temperature (°C)	-7	2	7	12		
PLR - Climate load factor	0.88	0.54	0.35	0.15		
DC - Output with full load	12.00	11.00	14.50	11.50		
COP with full load	2.85	3.60	4.70	5.46		
COP with part load	2,73	3,90	4,90	4,26		
CR - Load factor	1,00	0,67	0,33	0,18		
f COP - Corrective factor	1,00	1,08	1,04	0,78		

The performance values comply with Standards UNI EN 14511 and UNI EN 14825.
The performance values with a part load refer to a water delivery temperature of 35°C.

COOLING

EER	Load factor	Outdoor temperature (°C)	EER	Nominal capacity (kW)
EER1	100%	35	2.55	12.70
EER2	75%	30	3.85	9.53
EER3	50%	25	5.80	6.35
EER4	25%	20	6.74	3.18

Performance in accordance with UNI EN 14825.

HP EXTERNAL UNIT 016 – SPRINT WH L**HEATING****Performance with full load**

Delivery temperature	35°C		45°C		55°C	
	Nominal capacity (kW)	COP	Nominal capacity (kW)	COP	Nominal capacity (kW)	COP
Outdoor temperature						
-7	13.10	2.70	12.80	2.25	12.50	2.00
2	13.00	3.45	12.70	2.85	13.30	2.40
7	16.00	4.50	16.00	3.60	16.00	2.90
12	14.03	5.58	13.76	4.22	12.69	3.44
15	14.48	5.97	14.21	4.46	13.22	3.61
20	12.95	6.88	12.22	4.71	11.19	3.68
35	12.80	9.06	12.48	6.02	10.38	4.57

Performance with part load

Tbival (-7°C)	A	B	C	D		
Outdoor temperature (°C)	-7	2	7	12		
PLR – Climate load factor	0.88	0.54	0.35	0.15		
DC – Output with full load	13.10	13.00	16.00	14.03		
COP with full load	2.70	3.45	4.50	5.58		
COP with part load	2,66	3,80	4,81	4,32		
CR – Load factor	1,00	0,63	0,33	0,16		
f COP – Corrective factor	1,00	1,10	1,07	0,77		

The performance values comply with Standards UNI EN 14511 and UNI EN 14825.
The performance values with a part load refer to a water delivery temperature of 35°C.

COOLING

EER	Load factor	Outdoor temperature (°C)	EER	Nominal capacity (kW)
EER1	100%	35	2.45	14.00
EER2	75%	30	3.63	10.50
EER3	50%	25	5.27	7.00
EER4	25%	20	7.29	3.50

Performance in accordance with UNI EN 14825.

UNI 11300 PART 3 AND 4: PERFORMANCE AS PER UNI EN 14511 AND UNI EN 14825 – 12T TO 16T**HP EXTERNAL UNIT 012T – SPRINT WH L****HEATING****Performance with full load**

Delivery temperature	35°C		45°C		55°C	
	Nominal capacity (kW)	COP	Nominal capacity (kW)	COP	Nominal capacity (kW)	COP
Outdoor temperature						
-7	10.00	3.00	10.20	2.40	9.80	2.05
2	9.20	3.90	10.60	3.00	11.30	2.50
7	12.10	4.95	12.30	3.80	12.00	3.10
12	10.98	5.75	11.10	4.26	9.53	3.17
15	11.00	5.97	11.20	4.52	9.12	3.20
20	10.77	7.18	11.19	5.16	9.00	3.61
35	11.55	8.78	11.45	6.17	10.00	4.86

Performance with part load

Tbival (-7°C)	A	B	C	D		
Outdoor temperature (°C)	-7	2	7	12		
PLR – Climate load factor	0.88	0.54	0.35	0.15		
DC – Output with full load	10.00	9.20	12.10	10.98		
COP with full load	3.00	3.90	4.95	5.75		
COP with part load	2,82	4,01	4,85	4,14		
CR – Load factor	1,00	0,70	0,35	0,16		
f COP – Corrective factor	1,00	1,03	0,98	0,72		

The performance values comply with Standards UNI EN 14511 and UNI EN 14825.
The performance values with a part load refer to a water delivery temperature of 35°C.

COOLING

EER	Load factor	Outdoor temperature (°C)	EER	Nominal capacity (kW)
EER1	100%	35	2.75	11.60
EER2	75%	30	3.93	8.70
EER3	50%	25	5.73	5.80
EER4	25%	20	6.75	2.90

Performance in accordance with UNI EN 14825.

HEAT PUMPS

Split air-water heat pumps

HP EXTERNAL UNIT 014T – SPRINT WH L

HEATING						
Performance with full load						
Delivery temperature	35°C		45°C		55°C	
	Nominal capacity (kW)	COP	Nominal capacity (kW)	COP	Nominal capacity (kW)	COP
Outdoor temperature						
-7	12.00	2.85	11.70	2.35	11.00	2.05
2	11.00	3.60	11.50	2.85	12.40	2.45
7	14.50	4.70	14.20	3.65	13.80	3.00
12	11.50	5.46	11.69	4.12	10.28	3.32
15	11.62	5.67	11.89	4.25	9.84	3.41
20	11.09	6.27	11.47	4.87	9.53	3.74
35	11.77	8.63	11.99	6.10	10.09	4.93
Performance with part load						
Tbival (-7°C)	A	B	C	D		
Outdoor temperature (°C)	-7	2	7	12		
PLR - Climate load factor	0.88	0.54	0.35	0.15		
DC - Output with full load	12.00	11.00	14.50	11.50		
COP with full load	2.85	3.60	4.70	5.46		
COP with part load	2,73	3,90	4,90	4,26		
CR - Load factor	1,00	0,67	0,33	0,18		
f COP - Corrective factor	1,00	1,08	1,04	0,78		

The performance values comply with Standards UNI EN 14511 and UNI EN 14825.
The performance values with a part load refer to a water delivery temperature of 35°C.

COOLING

EER	Load factor	Outdoor temperature (°C)	EER	Nominal capacity (kW)
EER1	100%	35	2.55	12.70
EER2	75%	30	3.85	9.53
EER3	50%	25	5.80	6.35
EER4	25%	20	6.74	3.18

Performance in accordance with UNI EN 14825.

HP EXTERNAL UNIT 016T – SPRINT WH L

HEATING						
Performance with full load						
Delivery temperature	35°C		45°C		55°C	
	Nominal capacity (kW)	COP	Nominal capacity (kW)	COP	Nominal capacity (kW)	COP
Outdoor temperature						
-7	13.10	2.70	12.80	2.25	12.50	2.00
2	13.00	3.45	12.70	2.85	13.30	2.40
7	16.00	4.50	16.00	3.60	16.00	2.90
12	14.03	5.58	13.76	4.22	12.69	3.44
15	14.48	5.97	14.21	4.46	13.22	3.61
20	12.95	6.88	12.22	4.71	11.19	3.68
35	12.80	9.06	12.48	6.02	10.38	4.57
Performance with part load						
Tbival (-7°C)	A	B	C	D		
Outdoor temperature (°C)	-7	2	7	12		
PLR - Climate load factor	0.88	0.54	0.35	0.15		
DC - Output with full load	13.10	13.00	16.00	14.03		
COP with full load	2.70	3.45	4.50	5.58		
COP with part load	2,66	3,80	4,81	4,32		
CR - Load factor	1,00	0,63	0,33	0,16		
f COP - Corrective factor	1,00	1,10	1,07	0,77		

The performance values comply with Standards UNI EN 14511 and UNI EN 14825.
The performance values with a part load refer to a water delivery temperature of 35°C.

COOLING

EER	Load factor	Outdoor temperature (°C)	EER	Nominal capacity (kW)
EER1	100%	35	2.45	14.00
EER2	75%	30	3.63	10.50
EER3	50%	25	5.27	7.00
EER4	25%	20	7.29	3.50

Performance in accordance with UNI EN 14825.

OPERATING LIMITS

HEATING MODE

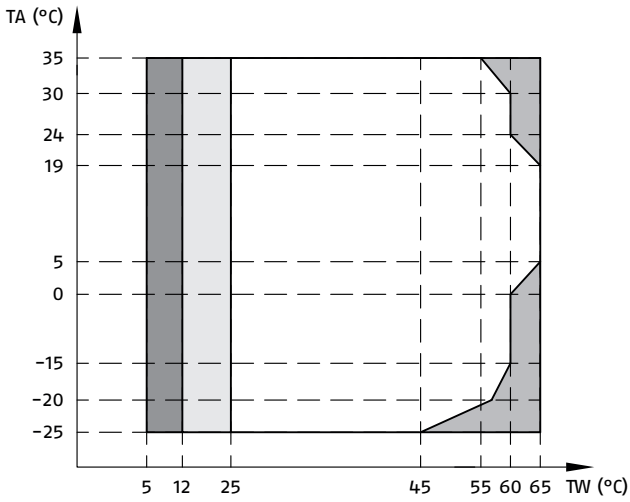

TA Outdoor air temperature
TW Water delivery temperature.

- Operating range with heat pump, with possible limits and protection.
- The heat pump switches off and only the external heat source is active.
- If the external heat source setting is enabled, only the external heat source activates. If the external heat source setting is disabled, only the heat pump is active. Limitations and protection may arise while the heat pump is operating.

COOLING MODE

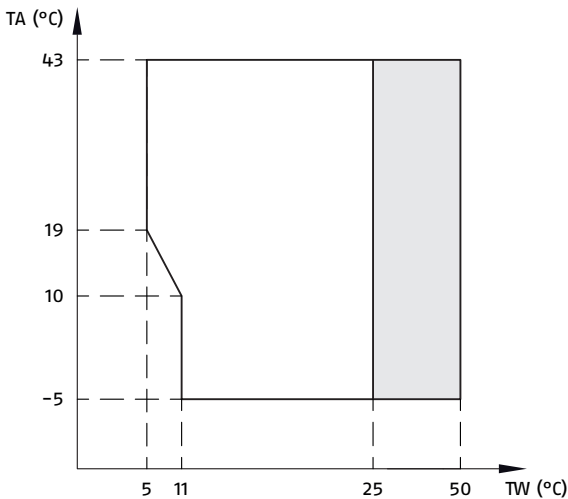

TA Outdoor air temperature
TW Water delivery temperature.

- Operating range with heat pump, with possible limits and protection.

DHW MODE

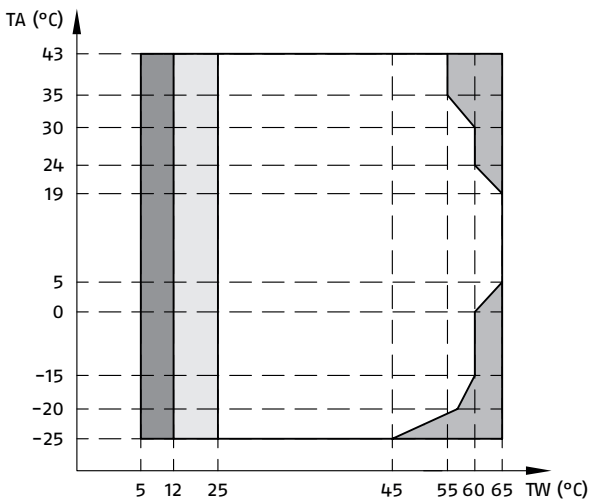

TA Outdoor air temperature
TW Water delivery temperature.

- Operating range with heat pump, with possible limits and protection.
- The heat pump switches off and only the external heat source is active.
- If the external heat source setting is enabled, only the external heat source activates. If the external heat source setting is disabled, only the heat pump is active. Limitations and protection may arise while the heat pump is operating.

HEAT PUMPS

Split air-water heat pumps

SOUND PRESSURE LEVEL

DESCRIPTION	U.M.	HP EXTERNAL UNIT									
		004	006	008	010	012	014	016	012T	014T	016T
Sound pressure (1)	dB (2)	44	45	46	49	50	51	55	50	51	55

- The sound pressure level is measured at a position 1 m in front of the unit and $(1+H)/2$ m (where H is the height of the unit) above the floor in a semi-anechoic chamber. During on-site operation, sound pressure levels may be higher due to ambient noise. For the 16 kW model, the value is calculated and used for reference only.
- dB is the maximum value tested under the following conditions:
 Outdoor air temperature 7°C DB, 85% R.H.; EWT 30°C, LWT 35°C. Variable compressor frequency.
 Outdoor air temperature 35°C DB; EWT 23°C, LWT 18°C. Variable compressor frequency.

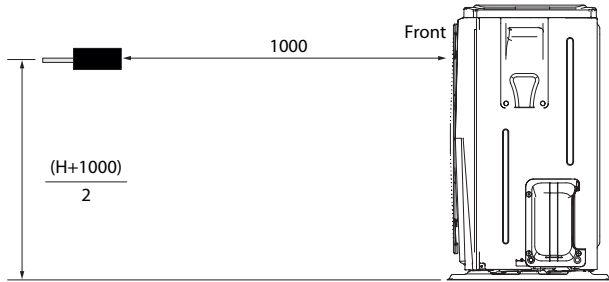

Unit of measurement: mm.

HP EXTERNAL UNIT 004

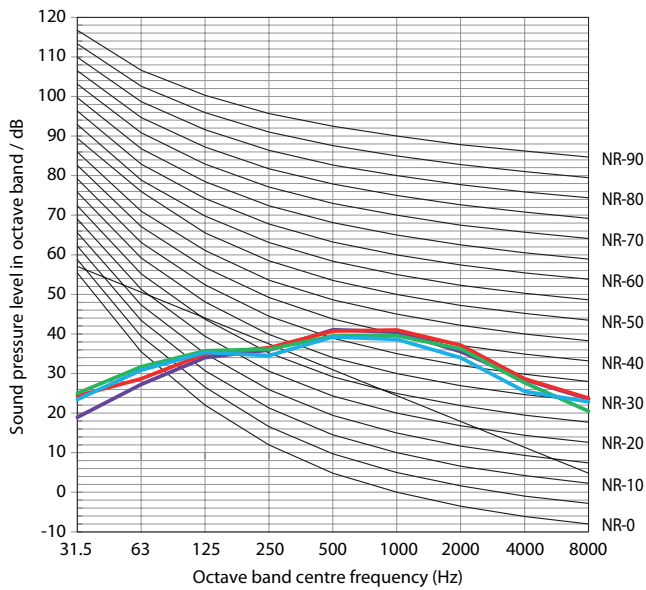

- Cooling at rated frequency
Outdoor air temperature 35°C dry bulb - Water inlet temperature 12°C - Water outlet temperature 7°C.
- Cooling at rated frequency
Outdoor air temperature 35°C dry bulb - Water inlet temperature 23°C - Water outlet temperature 18°C.

HP EXTERNAL UNIT 006

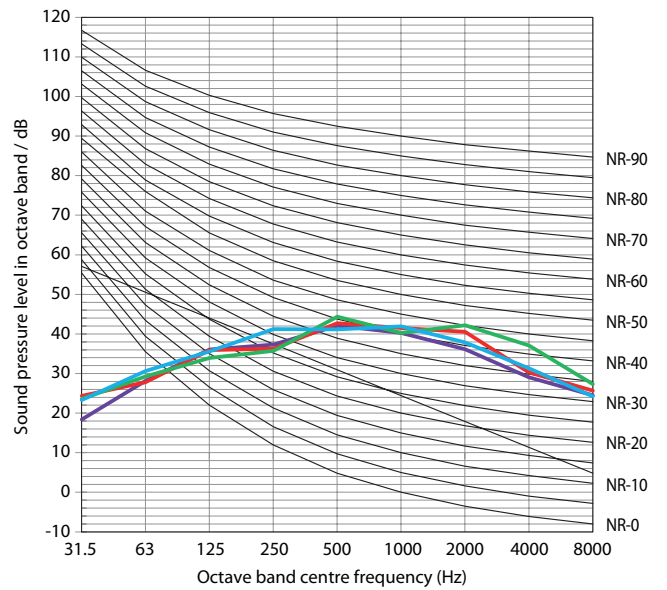

- Heating at rated frequency
Outdoor air temperature 7°C dry bulb - Relative humidity 85% - Water inlet temperature 30°C - Water outlet temperature 35°C.
- Heating at rated frequency
Outdoor air temperature 7°C dry bulb - Relative humidity 85% - Water inlet temperature 40°C - Water outlet temperature 45°C.

HP EXTERNAL UNIT 008

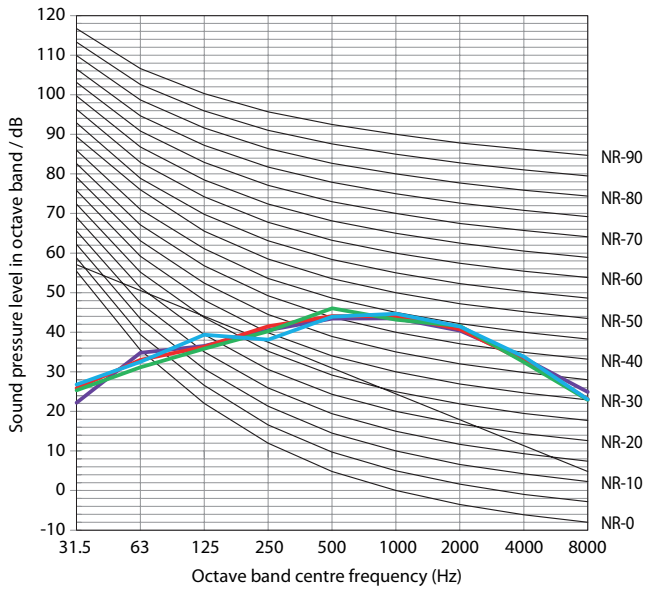

- Cooling at rated frequency
Outdoor air temperature 35°C dry bulb - Water inlet temperature 12°C - Water outlet temperature 7°C.
- Cooling at rated frequency
Outdoor air temperature 35°C dry bulb - Water inlet temperature 23°C - Water outlet temperature 18°C.
- Heating at rated frequency
Outdoor air temperature 7°C dry bulb - Relative humidity 85% - Water inlet temperature 30°C - Water outlet temperature 35°C.

HP EXTERNAL UNIT 010

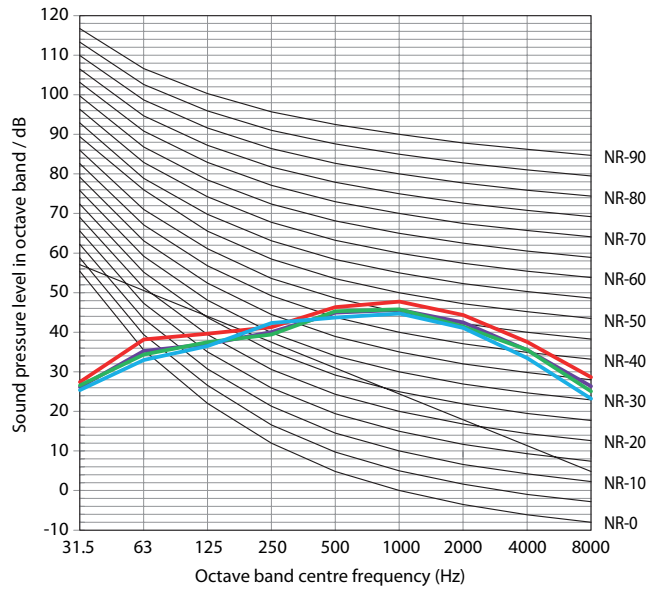

- Heating at rated frequency
Outdoor air temperature 7°C dry bulb - Relative humidity 85% - Water inlet temperature 30°C - Water outlet temperature 35°C.
- Heating at rated frequency
Outdoor air temperature 7°C dry bulb - Relative humidity 85% - Water inlet temperature 40°C - Water outlet temperature 45°C.
- Cooling at rated frequency
Outdoor air temperature 35°C dry bulb - Water inlet temperature 23°C - Water outlet temperature 18°C.

HP EXTERNAL UNIT 012

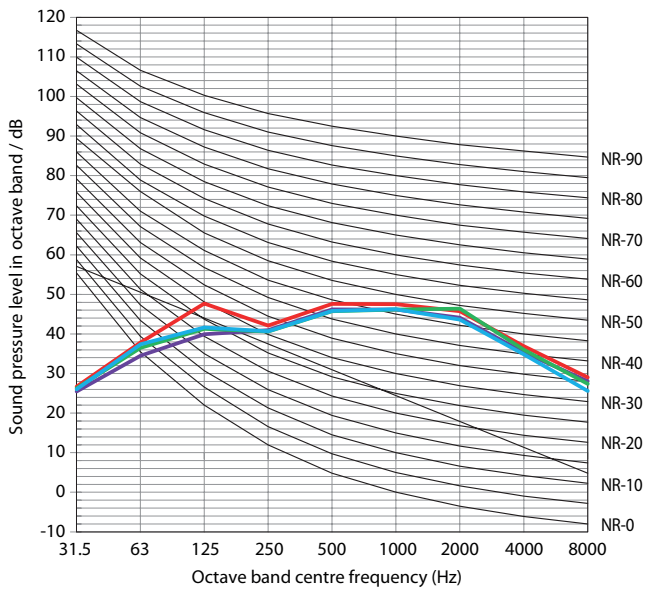

- Cooling at rated frequency
Outdoor air temperature 35°C dry bulb - Water inlet temperature 12°C - Water outlet temperature 7°C.
- Cooling at rated frequency
Outdoor air temperature 35°C dry bulb - Water inlet temperature 23°C - Water outlet temperature 18°C.
- Heating at rated frequency
Outdoor air temperature 7°C dry bulb - Relative humidity 85% - Water inlet temperature 30°C - Water outlet temperature 35°C.

HP EXTERNAL UNIT 014

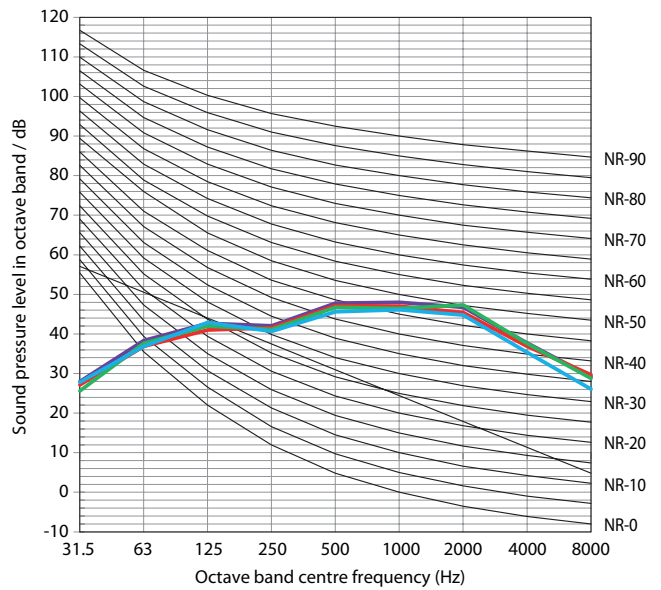

- Heating at rated frequency
Outdoor air temperature 7°C dry bulb - Relative humidity 85% - Water inlet temperature 30°C - Water outlet temperature 35°C.
- Heating at rated frequency
Outdoor air temperature 7°C dry bulb - Relative humidity 85% - Water inlet temperature 40°C - Water outlet temperature 45°C.
- Cooling at rated frequency
Outdoor air temperature 35°C dry bulb - Water inlet temperature 23°C - Water outlet temperature 18°C.

HEAT PUMPS

Split air-water heat pumps

HP EXTERNAL UNIT 012T

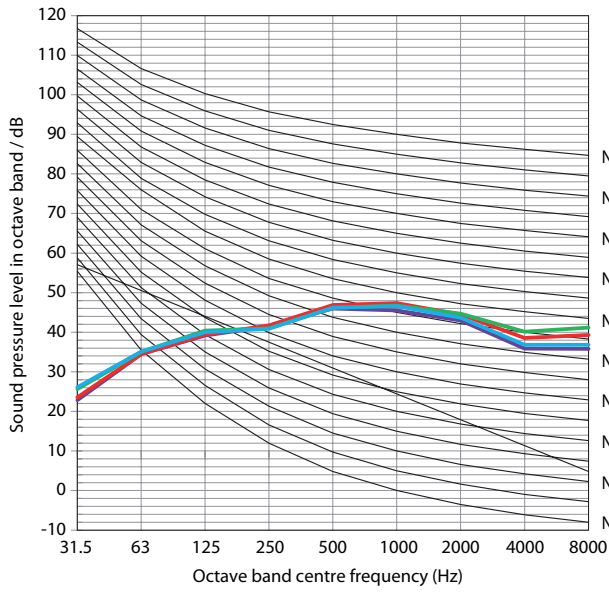

- Cooling at rated frequency
Outdoor air temperature 35°C dry bulb - Water inlet temperature 12°C - Water outlet temperature 7°C.
- Cooling at rated frequency
Outdoor air temperature 35°C dry bulb - Water inlet temperature 23°C - Water outlet temperature 18°C.
- Heating at rated frequency
Outdoor air temperature 7°C dry bulb - Relative humidity 85% - Water inlet temperature 30°C - Water outlet temperature 35°C.

HP EXTERNAL UNIT 014T

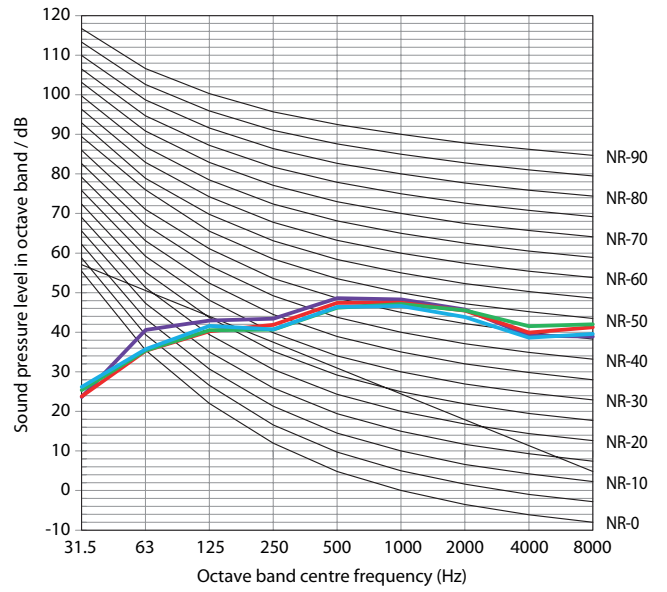

- Heating at rated frequency
Outdoor air temperature 7°C dry bulb - Relative humidity 85% - Water inlet temperature 30°C - Water outlet temperature 35°C.
- Heating at rated frequency
Outdoor air temperature 7°C dry bulb - Relative humidity 85% - Water inlet temperature 40°C - Water outlet temperature 45°C.

FOOTPRINT AND WEIGHT

INDOOR UNIT DIMENSIONS (1)

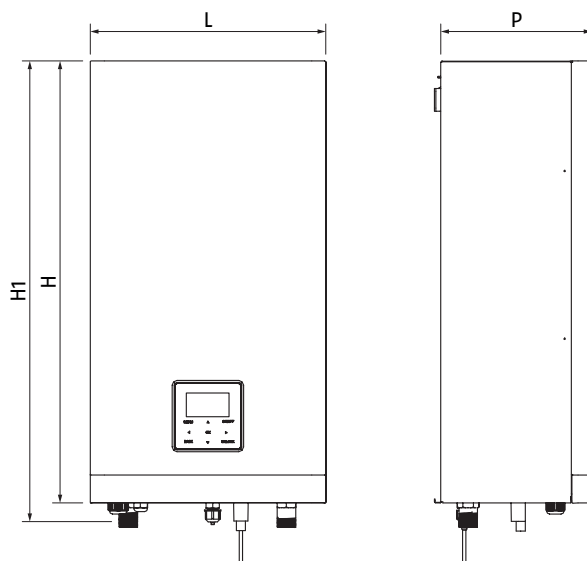

Models	U.M.	SPRINT WH S (4-6 kW)	SPRINT WH M (8-10 kW)	SPRINT WH L (12-16 kW)
Width (W)	mm	421	421	421
Height (H)	mm	790	790	790
Height (H1)	mm	824	824	824
Depth (D)	mm	270	270	270
Net weight	kg	37	37	39
Gross weight	kg	43	43	45

(1) Dimensions valid for versions with or without backup heating element.

OUTDOOR UNIT DIMENSIONS

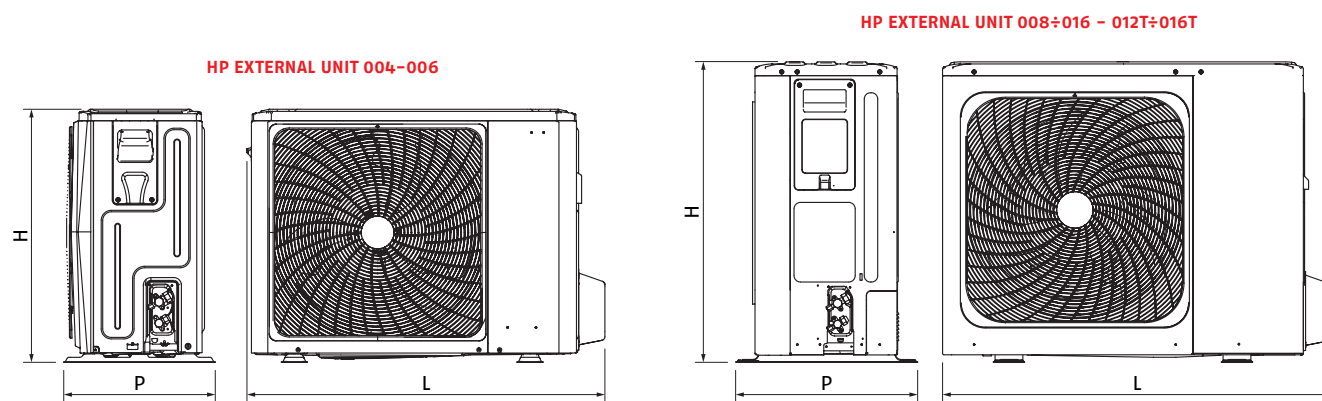

Models	U.M.	004	006	008	010	012	014	016	012T	014T	016T
Width (W)	mm	1008	1008	1118	1118	1118	1118	1118	1118	1118	1118
Height (H)	mm	712	712	865	865	865	865	865	865	865	865
Depth (D)	mm	426	426	523	523	523	523	523	523	523	523
Net weight	kg	58	58	75	75	97	97	97	112	112	112
Gross weight	kg	63.5	63.5	89	89	110.5	110.5	110.5	125.5	125.5	125.5

HEAT PUMPS

Split air-water heat pumps

PLACE OF INSTALLATION

PRELIMINARY WARNINGS FOR R32

The appliance must be installed in a well-ventilated room with the minimum floor area stated in the Minimum Floor Area table, in accordance with the overall refrigerant load in the circuit.

Refrigerant load refers to the overall load in the circuit calculated by adding the factory load and any additional load.

See the nameplate on the paired outdoor unit for the quantity of refrigerant gas loaded in the unit.

If the appliance is to be installed in a poorly ventilated room, steps must be taken to prevent stagnation in the event of refrigerant leakage, so as not to create a risk of fire or explosion.

The appliance must be installed in a room where there are no open flames continuously in operation (e.g. a gas appliance running) or ignition sources (e.g. an electric heater running).

Any vents must be kept clear of obstacles.

Run the following checks:

- run safety checks to ensure the combustion risk is reduced to a minimum
- avoid working in confined spaces
- delimit the area around the work space
- ensure safe working conditions around the area by controlling flammable material.

MINIMUM FLOOR AREA

m(kg)	1.8	2.0	2.2	2.4	2.6	2.8	3.0	3.2	3.4	3.6	3.8	4.0	4.2	4.4	4.6	4.8	5.0	5.2	5.4	5.6	5.8	6.0	6.2
A _{min} (m ²)	No limitations	3.81	4.61	5.49	6.44	7.47	8.58	9.76	11.02	12.36	13.77	15.26	16.82	18.46	20.18	21.97	23.84	25.79	27.81	29.91	32.09	34.34	36.67

The clearances for appliance assembly and maintenance are shown in the figure. These clearances are necessary to avoid blocking the air flow and to allow normal cleaning and maintenance.

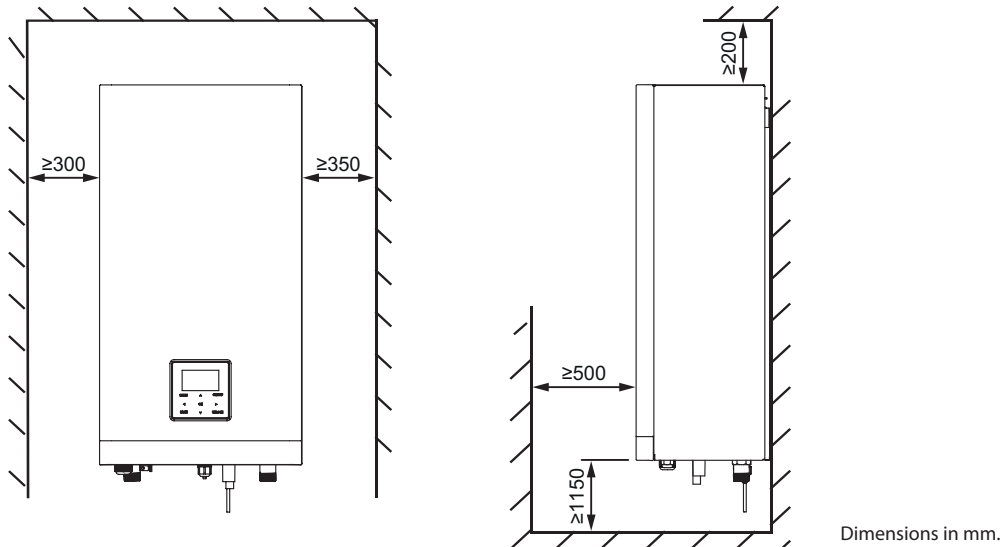

In normal conditions

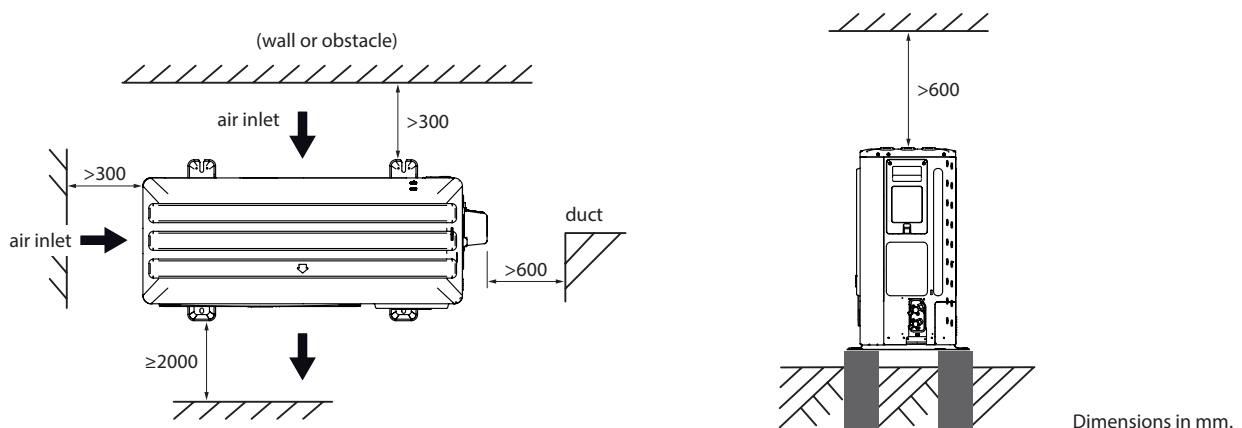

In a cold climate

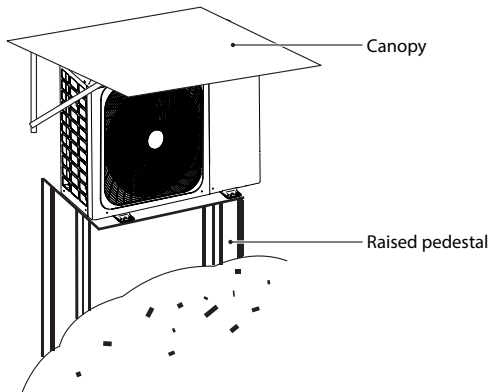

In a stacked installation

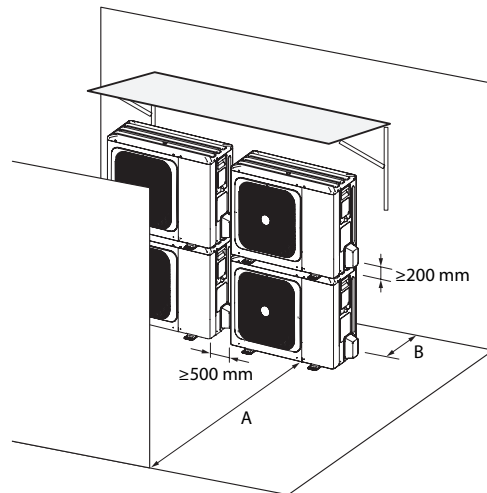

	A	B
	mm	mm
HP EXTERNAL UNIT 004÷016	≥2000	≥300

A: With a front obstacle. - B: With a rear obstacle.

When installed in rows

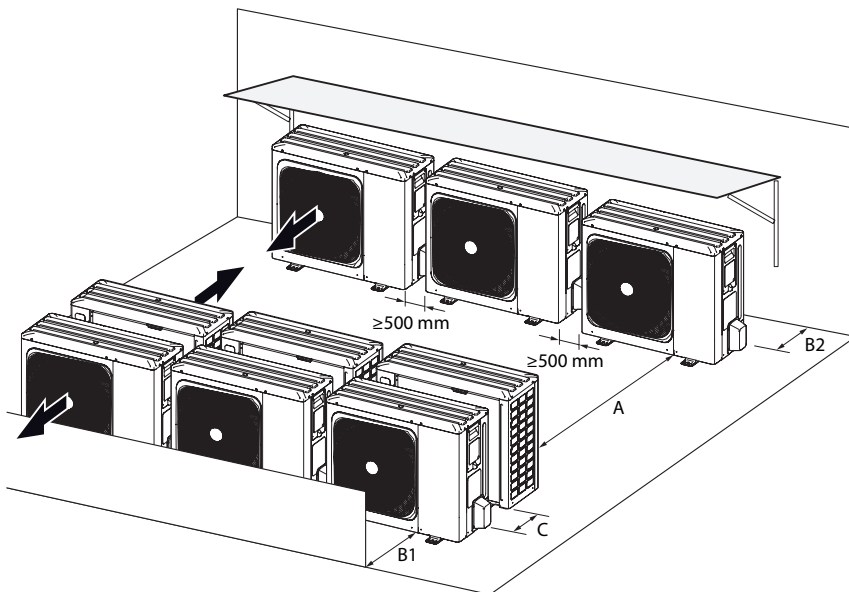

	A	B1	B2	C
	mm	mm	mm	mm
HP EXTERNAL UNIT 004÷016	≥3000	≥2000	≥300	≥600

HEAT PUMPS

Split air-water heat pumps

STRUCTURE

INDOOR UNIT COMPONENTS

Models without backup heating element

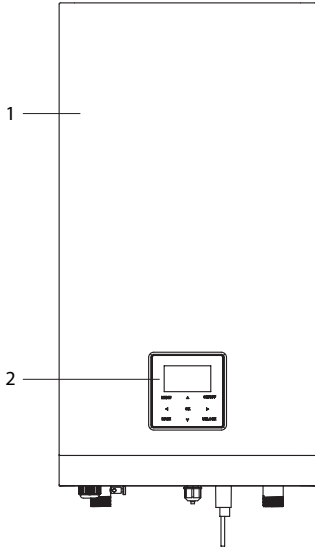

- 1. Access panel
- 2. Control panel
- 3. Electrical panel
- 4. Terminal board
- 5. Automatic breather valve
- 6. Anti-freeze heating element
- 7. Expansion vessel

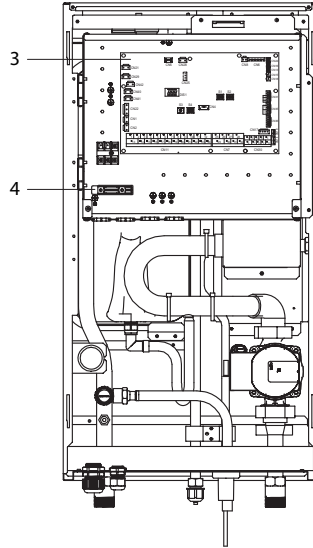

- 8. Pressure gauge
- 9. Safety valve
- 10. Water outlet pipe
- 11. Refrigerant gas pipe
- 12. Drainage port
- 13. Refrigerant liquid pipe
- 14. Water inlet pipe

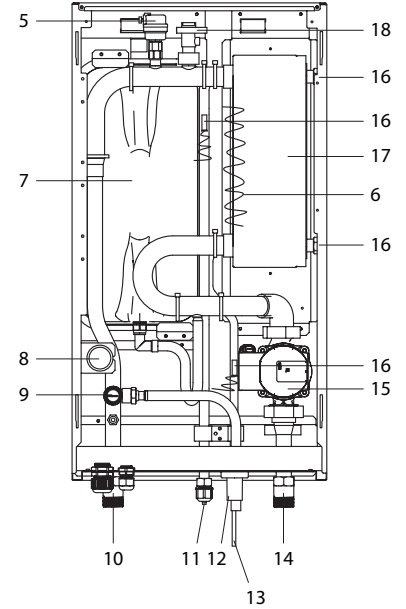

- 15. Primary circulation pump PP1
- 16. Temperature sensors
- 17. Plate heat exchanger
- 18. Flow switch

Models with backup heating element

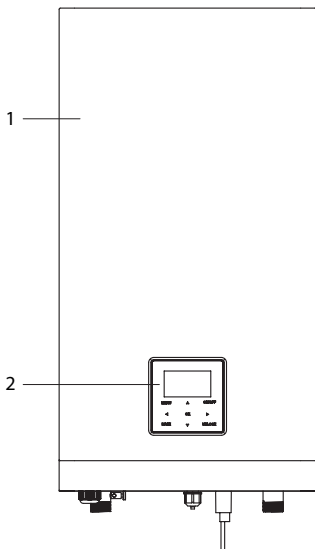

- 1. Access panel
- 2. Control panel
- 3. Electrical panel
- 4. Terminal board
- 5. Automatic breather valve
- 6. Anti-freeze heating element
- 7. Expansion vessel

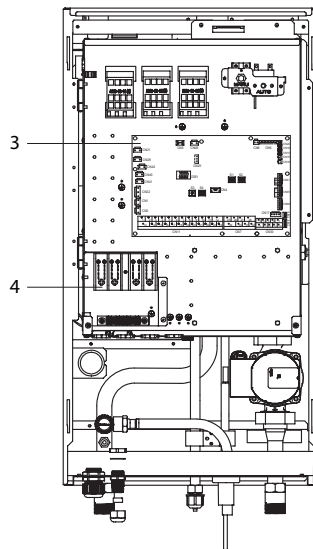

- 8. Pressure gauge
- 9. Safety valve
- 10. Water outlet pipe
- 11. Refrigerant gas pipe
- 12. Drainage port
- 13. Refrigerant liquid pipe
- 14. Water inlet pipe

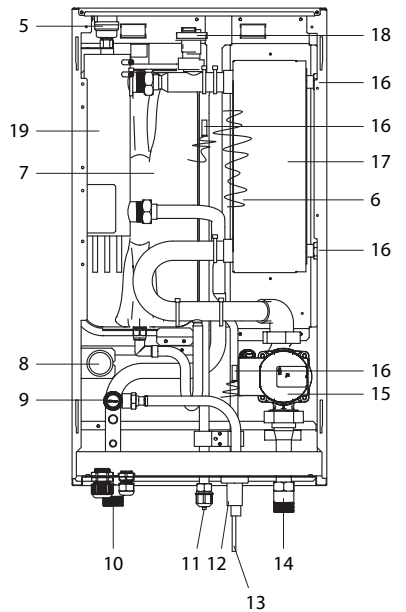

- 15. Primary circulation pump PP1
- 16. Temperature sensors
- 17. Plate heat exchanger
- 18. Flow switch
- 19. Internal backup heater

OUTDOOR UNIT COMPONENTS

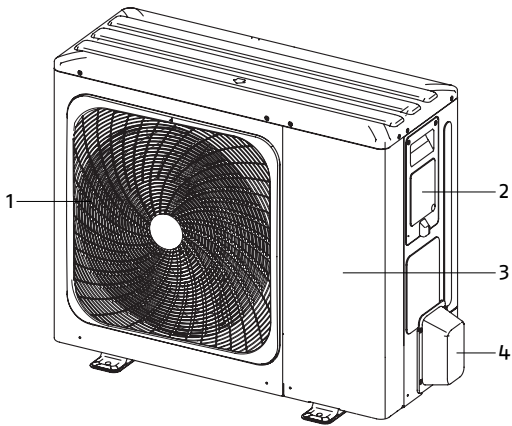

- 1. Electric fan grille
- 2. Electrical connections panel
- 3. Access panel
- 4. Hydraulic connections panel

HYDRAULIC AND REFRIGERANT CONNECTIONS

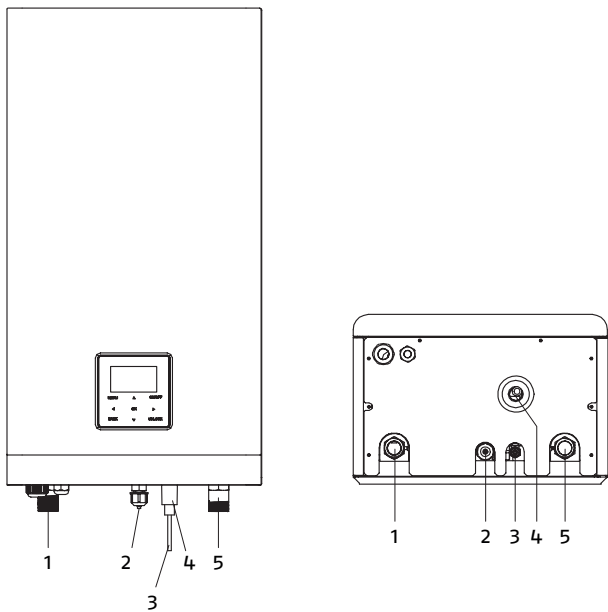

- 1. System delivery
- 2. Refrigerant gas fitting
- 3. Refrigerant liquid fitting
- 4. Safety valve drain
- 5. System return

Model	U.M.	SPRINT WH S (4-6 kW)	SPRINT WH M (8-10 kW)	SPRINT WH L (12÷16 kW)
System delivery	Inches	1"	1"	1"
Refrigerant gas fitting	Inches	Ø5/8"	Ø5/8"	Ø5/8"
	mm	Ø15.88	Ø15.88	Ø15.88
Refrigerant liquid fitting	Inches	Ø1/4"	Ø3/8"	Ø3/8"
	mm	Ø6.35	Ø9.52	Ø9.52
Safety valve drain	mm	Ø25	Ø25	Ø25
System return	Inches	1"	1"	1"

Connections valid for versions with or without backup heating element.

HEAT PUMPS

Split air-water heat pumps

HP EXTERNAL UNIT 004-006

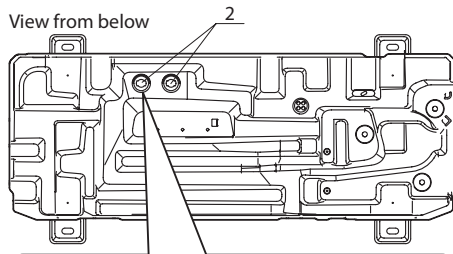
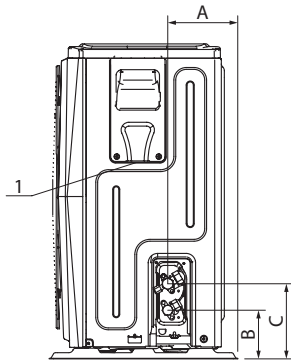

This drain hole is covered by a rubber stopper. If one drain hole cannot meet requirements, the other one can also be used at the same time.

HP EXTERNAL UNIT 008÷016 - 012T÷016T

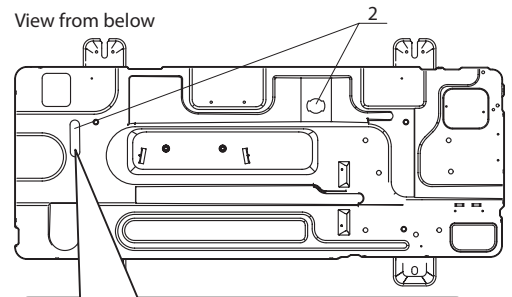
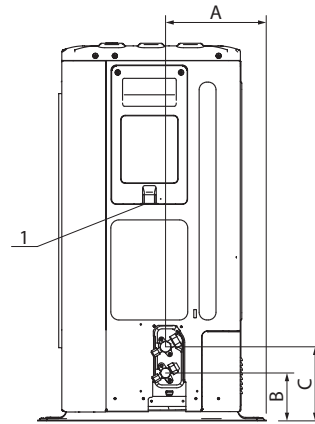

This drain hole is covered by a rubber stopper. If the small drain hole cannot meet the drainage requirements, the large drain hole can be used at the same time.

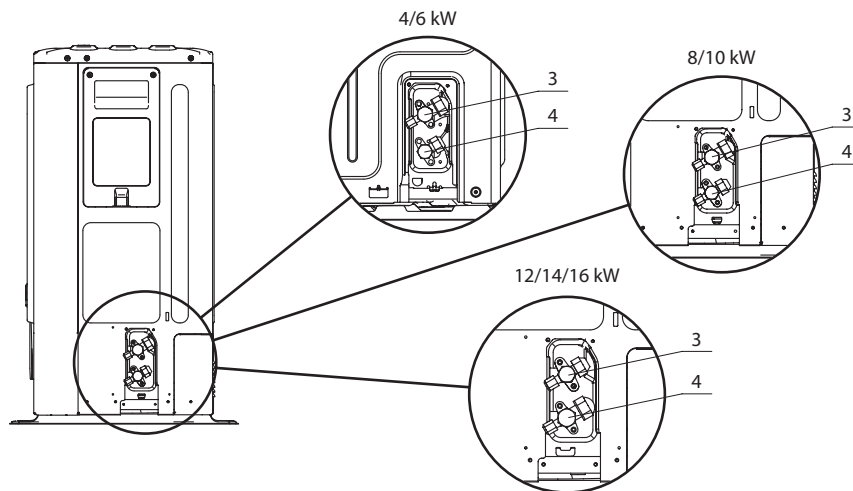

	Model	U.M.	HP EXTERNAL UNIT 004-006	HP EXTERNAL UNIT 008÷016 - 012T÷016T
1	Hole for electrical connections	∅ mm	-	-
2	Condensate outlet hose fitting (included)	∅ mm	-	-
3	Refrigerant gas fitting	inches	∅5/8"	∅5/8"
		mm	∅15.88	∅15.88
4	Refrigerant liquid fitting	inches	∅1/4"	∅3/8"
		mm	∅6.35	∅9.52
A		mm	160	230
B		mm	110	110
C		mm	170	170

REFRIGERANT CONNECTIONS BETWEEN OUTDOOR UNIT AND INDOOR UNIT

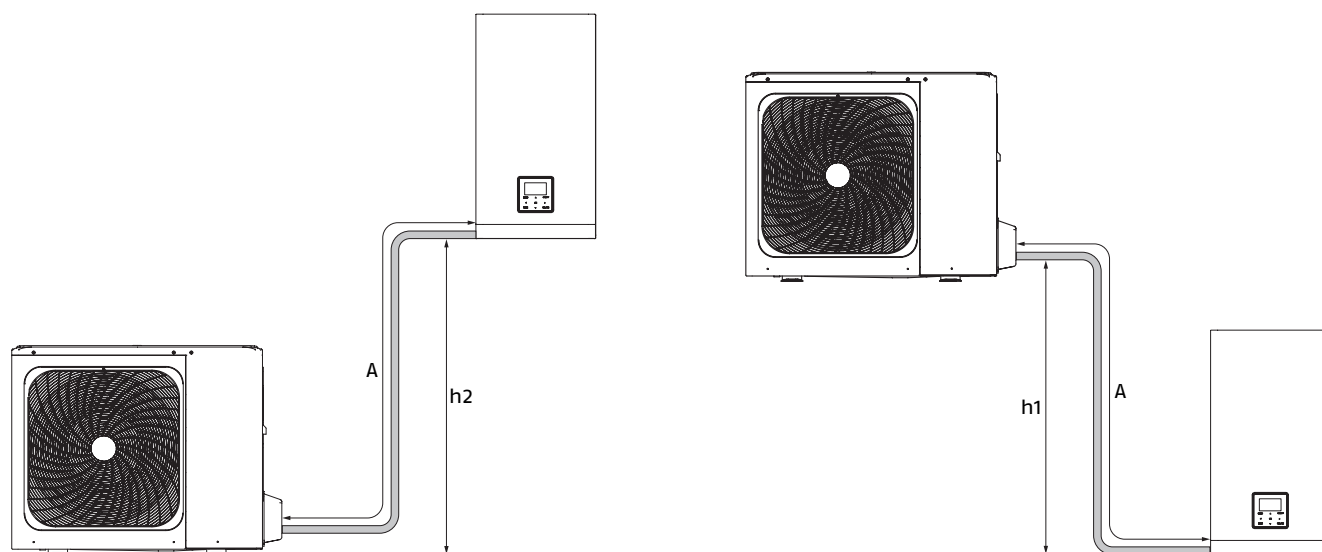

Model	U.M.	4÷6 kW	8÷16 kW	
Maximum permitted length	A	m	30	30
Permissible height difference between the 2 units if outdoor unit is positioned higher	h1	m	20	20
Permissible height difference between the 2 units if outdoor unit is positioned lower	h2	m	20	20
Length of connecting pipes without additional gas load		m	≤ 15	≤ 15
Additional load		g/m	20	38

There is no need for siphons on the refrigerant lines as the compressors of the outdoor units are equipped with oil separators. The measurements indicated are the maximum permitted.

HEAT PUMPS

Split air-water heat pumps

DIAGRAM OF FLOW RATE - HEAD - LOAD LOSS

Family Sprint is equipped with a variable-speed circulation pump.
When sizing the system, take account of the residual head shown in the graphs below.

Description	U.M.	SPRINT WH 4M	SPRINT WH 6M	SPRINT WH 8M	SPRINT WH 10M	SPRINT WH 12M	SPRINT WH 14M	SPRINT WH 16M	SPRINT WH 12T	SPRINT WH 14T	SPRINT WH 16T
Nominal flow rate	m ³ /h	0.73	1.07	1.43	1.72	2.09	2.50	2.76	2.09	2.50	2.76
Available head at nominal flow rate	Kpa	83	85	82	69	64	51	41	64	51	41

SPRINT WH S (4-6 kW) - SPRINT WH M (8-10 kW)

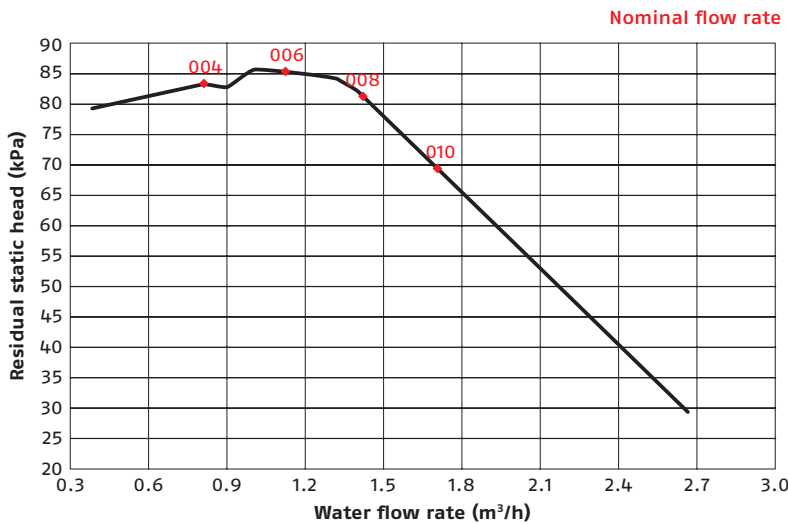

Indoor unit for Split system: 4/6 kW, 8/10 kW

Flow rate (m ³ /h)	Residual head (kPa)
2.64	29.45
2.55	33.27
2.45	37.39
2.35	41.51
2.24	46.33
2.14	50.65
2.04	54.57
1.95	58.59
1.82	64.32
1.71	69.14
1.61	73.67
1.52	77.59
1.41	82.21
1.30	83.82
1.21	84.82
1.10	85.83
1.00	86.73
0.92	83.62
0.81	83.01
0.69	81.90
0.56	80.80
0.46	79.80

SPRINT WH L (12÷16 kW)

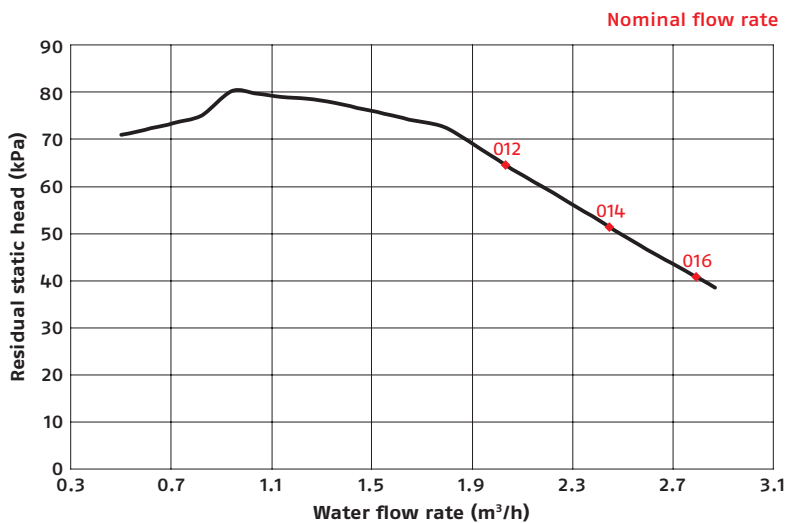

Indoor unit for Split system: 12/16 kW

Flow rate (m ³ /h)	Residual head (kPa)
2.87	38.59
2.78	41.31
2.67	44.52
2.57	47.44
2.47	50.65
2.38	53.67
2.25	57.79
2.15	60.90
2.06	63.72
1.94	67.84
1.84	71.15
1.77	72.96
1.65	74.27
1.55	75.48
1.44	76.78
1.35	77.79
1.24	78.69
1.14	79.09
1.04	79.80
0.94	80.20
0.82	80.20
0.71	80.20
0.62	80.20

QUALITY REQUIREMENTS OF SYSTEM FILLING WATER

At initial start-up, the specialised technician must test the reference values of the system water using special test kits. The quality of the water used must meet the requirements stated in the table below; otherwise, a treatment system must be installed.

System water reference values		
pH		6.5 – 7.8
Electrical conductivity	μS/cm	250 – 800
Total hardness	°F	5 – 15
Total iron	ppm	0.2
Manganese	ppm	< 0.05
Chlorides	ppm	< 250
Sulphur ions		none
Ammonia ions		none

Well or groundwater not coming from the aqueduct should always be carefully analysed and if necessary conditioned with appropriate treatment systems.

If the initial water hardness exceeds the value indicated in the table, a water softening system must be used.

Excessive water softening (total hardness < 1.5 mmol/l) could lead to corrosion on contact with metal elements (pipes or boiler parts). The conductivity value must also be kept within 600 μS/cm.

Check the chloride concentration at the outlet after regeneration of the resins.

It is strictly prohibited to introduce acids into the washing circuit.

It is strictly prohibited to constantly or frequently top up the system, as this can damage the heat exchanger of the appliance.

HYDRAULIC SYSTEM

Heat pumps require systems that guarantee a constant fluid flow rate to the device, within minimum and maximum values and with sufficient volumes to avoid any imbalance in the cooling circuits and ensure the correct degree of comfort.

WATER CONTENT

A minimum volume of water in the system's primary circuit must be guaranteed for the appliance to operate correctly.

The minimum volume is necessary to prevent the risk of ice formation during defrosting operations or continuous modulation of the compressor frequency.

It also provides the following advantages:

- less appliance wear;
- increase in system efficiency;
- improved stability and temperature precision.

If the minimum volume is not reached, a suitably sized storage tank must be installed.

The minimum volume must be guaranteed in all operating modes and in all conditions.

The minimum volume is stated in the table below:

R32 indoor unit		SPRINT WH S		SPRINT WH M		SPRINT WH L		
R32 outdoor unit		004	006	008	010	012 – 012T	014 – 014T	016 – 016T
Minimum system water content (1)	l	25	25	25	25	40	40	40
Minimum water flow rate	m ³ /h	0.45	0.65	0.85	1.05	1.25	1.35	1.50
Maximum water flow rate	m ³ /h	0.90	1.25	1.65	2.10	2.50	2.75	3.00

(1) Excluding the volume of water inside the unit.

HEAT PUMPS

Split air-water heat pumps

POWER LINE SIZING

INDOOR UNIT

In single-phase models with 3 kW heating element, the backup heating is set as per option 1 (factory setting). In three-phase models with 9 kW heating element, the backup heater is set as per option 3 (factory setting).

Split System	4-6 kW	8-10 kW	12-16 kW
Electric power supply	220-240V~50Hz	220-240V~50Hz	220-240V~50Hz
Rated input	95W	95W	95W
Rated current	0.4A	0.4A	0.4A

Split System	4-6 kW with heating element 3 kW	8-10 kW with heating element 3 kW	12-16 kW with heating element 3 kW	12-16 kW with heating element 9 kW
Electric power supply	220-240V~50Hz	220-240V~50Hz	220-240V~50Hz	380-415V 3N~50Hz
Rated input	3095W	3095W	3095W	9095W
Rated current	13.5A	13.5A	13.5A	13.5A
Electric heater	3000W	3000W	3000W	9000W

STANDARD WIRING COMPONENT SPECIFICATIONS

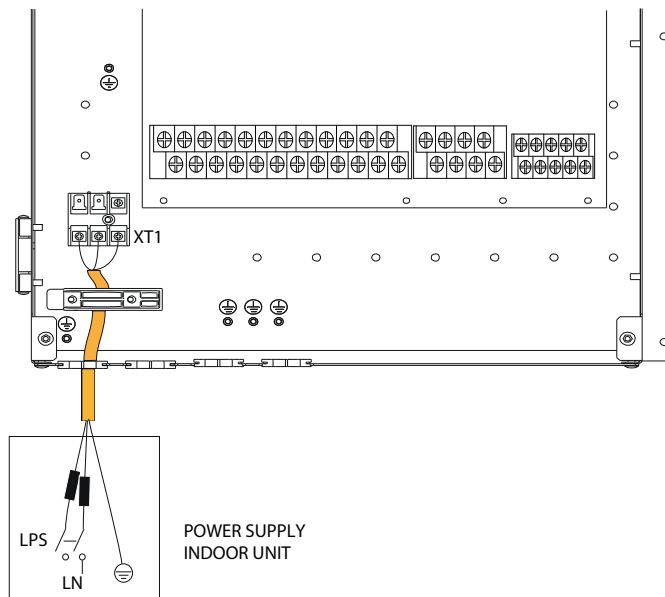

The stated values are nominal (see the installation manual for further information).

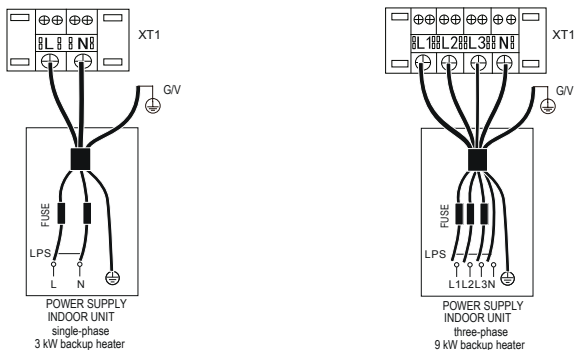

Unit	4±16 kW	4±16 kW M (1)	8±16 kW T (2)
Cable dimensions (mm ²)	1.5	4.0	4.0

The stated values are maximum values (see electrical data for exact values)

- (1) Unit with 3 kW heating element.
- (2) Unit with 9 kW heating element.

CONNECTIONS FOR OTHER COMPONENTS

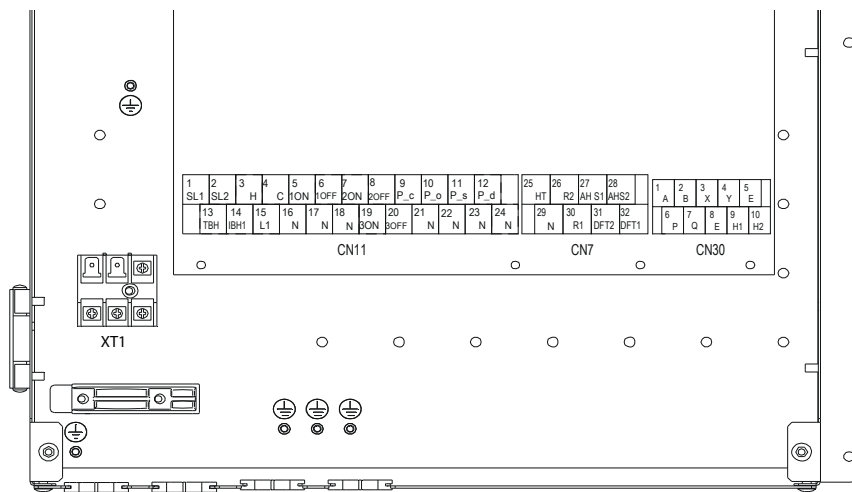

	Code	Print	Connection A	
CN11	1	1 SL1	Solar energy input signal	
		2 SL2		
	2	3	HL	Room thermostat input (high voltage)
		4	CL	
	3	5	10N	SV1 (3-way valve)
		6	10FF	
	4	7	20N	SV2 (3-way valve)
		8	20FF	
	5	9	PUMP C	Pump c (zone 2 pump)
		21	N	
	6	10	PUMP O	External circulation pump / zone 1
		22	N	
	7	11	PUMP S	Solar energy pump
		23	N	
	8	12	PUMP D	DHW tube pump
		24	N	
	9	13	TBH	Tank booster heater
		16	N	
	10	14	IBH1	Internal backup heater 1
		17	N	
11	18	N	SV3 (3-way valve)	
	19	30N		
	20	30FF		

	Code	Print	Connection A	
CN30	1	1 A	Wired controller	
		2 B		
	3	X		
	2	4	Y	Outdoor unit (*)
		5	E	
		6	P	
		7	Q	
		9	H1	
		10	H2	
		3		

	Code	Print	Connection A	
CN7	1	26 R2	Compressor operation	
		30 R1		
	2	31	DFT2	Defrosting operation
		32	DFT1	
	3	25	HT	Anti-freeze heating tape (external)
		29	N	
27		AHS1		
	28	AHS2	Additional heating source	
XT1	L		Indoor unit power supply	
	N			
	G			

The port supplies the load with the control signal. Two types of control signal port:
 Type 1: Volt-free contact.

Type 2: The port provides the signal with 220V voltage. If the load current is <0.2A, the load can connect directly to the port. If the load current is ≥0.2A, the load must be connected via a relay.

(*) Connection BUS cable 2 x 0.75 mm² shielded.

(**) Not used.

HEAT PUMPS

Split air-water heat pumps

OUTDOOR UNIT

Safety device requirement:

- Select cable diameters (minimum value) individually for each unit based on tables 1 and 2, where the rated current in table 1 means MCA in table 2. If MCA exceeds 63A, the cable diameters must be selected in accordance with national wiring regulations.
- The maximum permissible voltage range variation between phases is 2%.
- Select a circuit breaker that has a contact separation at all poles of not less than 3 mm and allows complete disconnection, where MFA is used to select current circuit breakers and differential switches.

CABLE SIZING

Use the tables below when sizing the power cables and safety equipment:

Table 1

Appliance rated current: (A)	Nominal cross-sectional area (mm ²)	
	Flexible cables	Fixed wiring cable
≤3	0.5 and 0.75	1 and 2.5
>3 and ≤6	0.75 and 1	1 and 2.5
>6 and ≤10	1 and 1.5	1 and 2.5
>10 and ≤16	1.5 and 2.5	1.5 and 4
>16 and ≤25	2.5 and 4	2.5 and 6
>25 and ≤32	4 and 6	4 and 10
>32 and ≤50	6 and 10	6 and 16
>50 and ≤63	10 and 16	10 and 25

Table 2 Standard 4–16 kW single-phase and standard 12–16 kW three-phase

System	Outdoor unit				Power supply current			Compressor		Fan	
	Voltage (V)	Hz	Min. (V)	Max. (V)	MCA (A)	TOCA (A)	MFA (A)	MSC (A)	RLA (A)	kW	FLA (A)
4 kW	220–240	50	198	264	12	18	25	-	11.50	0.10	0.50
6 kW	220–240	50	198	264	14	18	25	-	13.50	0.10	0.50
8 kW	220–240	50	198	264	16	19	25	-	14.50	0.17	1.50
10 kW	220–240	50	198	264	17	19	25	-	15.50	0.17	1.50
12 kW	220–240	50	198	264	25	30	35	-	23.50	0.17	1.50
14 kW	220–240	50	198	264	26	30	35	-	24.50	0.17	1.50
16 kW	220–240	50	198	264	27	30	35	-	25.50	0.17	1.50
12 kW Three-phase	380–415	50	342	456	10	14	16	-	9.15	0.17	1.50
14 kW Three-phase	380–415	50	342	456	11	14	16	-	10.15	0.17	1.50
16 kW Three-phase	380–415	50	342	456	12	14	16	-	11.15	0.17	1.50

MCA: Maximum circuit amps (A)

TOCA: Total overcurrent amps (A)

MFA: Maximum fuse amps (A)

MSC: Max. Starting current (A)

RLA: In nominal cooling or heating test conditions, the amps at compressor input where MAX. Hz can operate with the rated load amps (A)

kW: Motor nominal power

FLA: Full load amps (A)

REMOVE THE ELECTRICAL PANEL COVER

Standard 4-16 kW single-phase and standard 12-16 kW three-phase										
System	4 kW	6 kW	8 kW	10 kW	12 kW	14 kW	16 kW	12 kW Three-phase	14 kW Three-phase	16 kW Three-phase
Maximum overcurrent protection (MOP) (A)	18	18	19	19	30	30	30	14	14	14
Cable dimensions (mm ²)	4.0	4.0	4.0	4.0	6.0	6.0	6.0	2.5	2.5	2.5

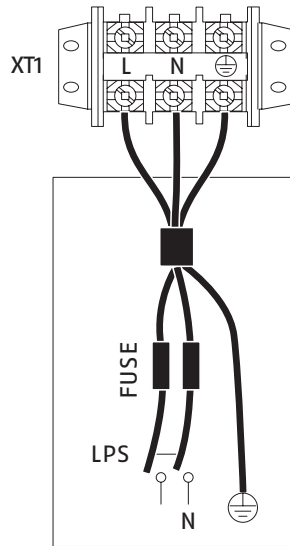
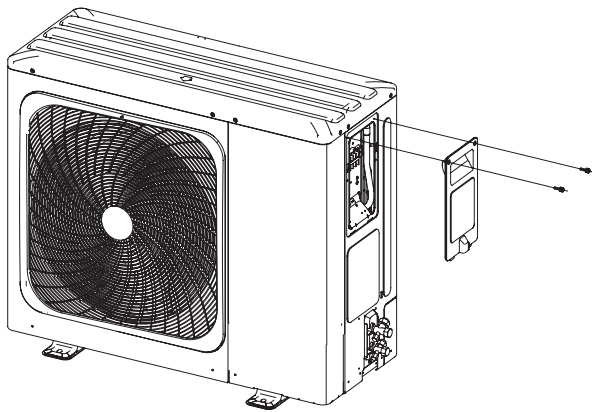

UNIT POWER SUPPLY
single-phase

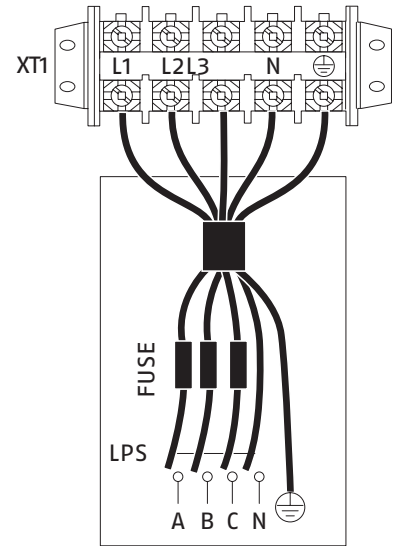

UNIT POWER SUPPLY
three-phase









HEAT PUMPS

Split air-water heat pumps

CONTROL PANEL (INSTALLER MANUAL)

INDOOR UNIT

The system control panel, on board the indoor unit, features a large backlit display with user-friendly icons and a multi-language menu.

Keys	Function
	Go to the menu structure (on the home page)
   	Move the cursor on the display Move within the menu structure Adjust the settings
	Activate/ deactivate room heating /cooling operation or DHW mode Activate or deactivate functions in the menu structure
	Go back to the next higher level
	Press and hold to unlock/lock the controller Unlock/lock certain functions such as 'DHW temperature control'.
	Go to the next step when setting a programming in the menu structure; confirm a selection to access a submenu in the menu structure

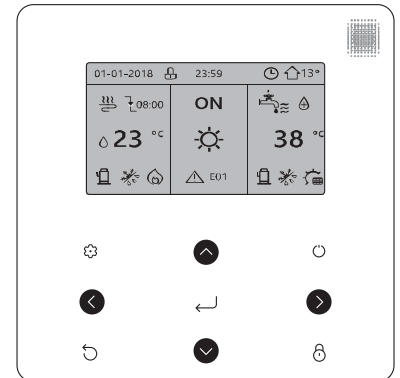

The interface normally displays the water temperature in the DHW tank and enables all operations relating to instrument use to be carried out, particularly:

- setting summer/winter operating mode
- viewing and rearming alarms
- checking the status of resources (setpoints, temperatures, outdoor unit and backup heater operating hours)

50 L INERTIA TANK

Insulated 50-litre inertia tank designed to minimise heat pump on/off cycles when the system is running at almost full capacity. The inertia tank ensures, if required, the minimum water content in the system that the heat pump needs, depending on the installed capacity. This ensures the machine runs efficiently and optimally even in part load conditions.

- For hot and cold applications;
- It can be installed vertically or horizontally, inside or outside the building;
- It can be installed horizontally under the heat pump, thus minimising any space availability issues;
- Filling and emptying caps;
- Fitted with rubber elements to dampen the vibration generated by the heat pump.

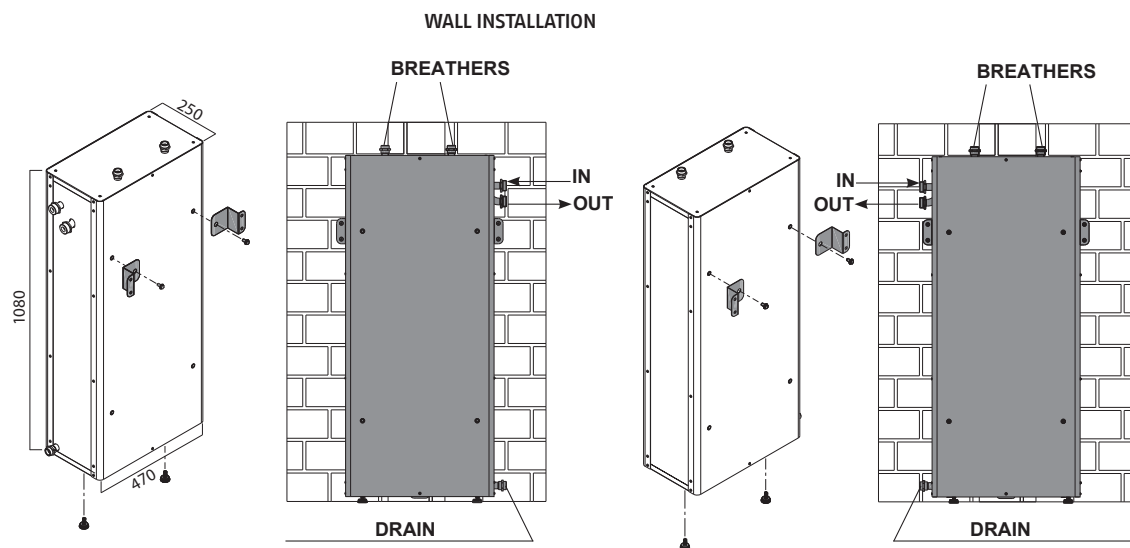

HEAT PUMPS

Split air-water heat pumps

FLOOR INSTALLATION

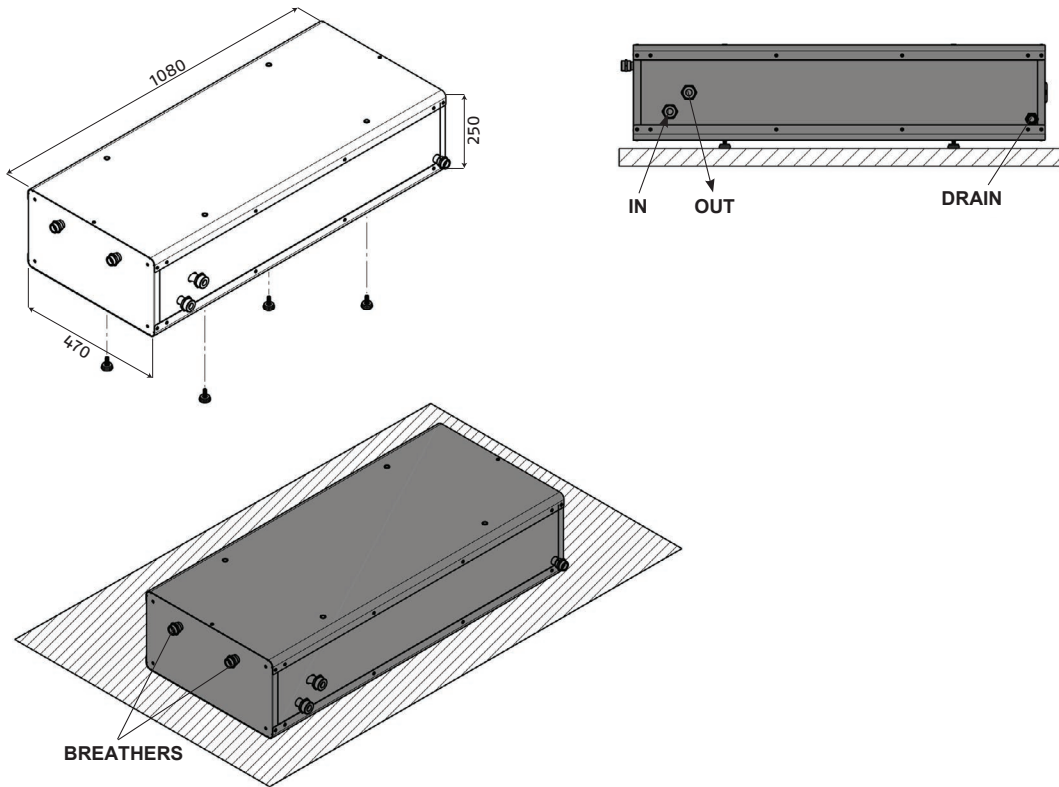

HEAD LOSS

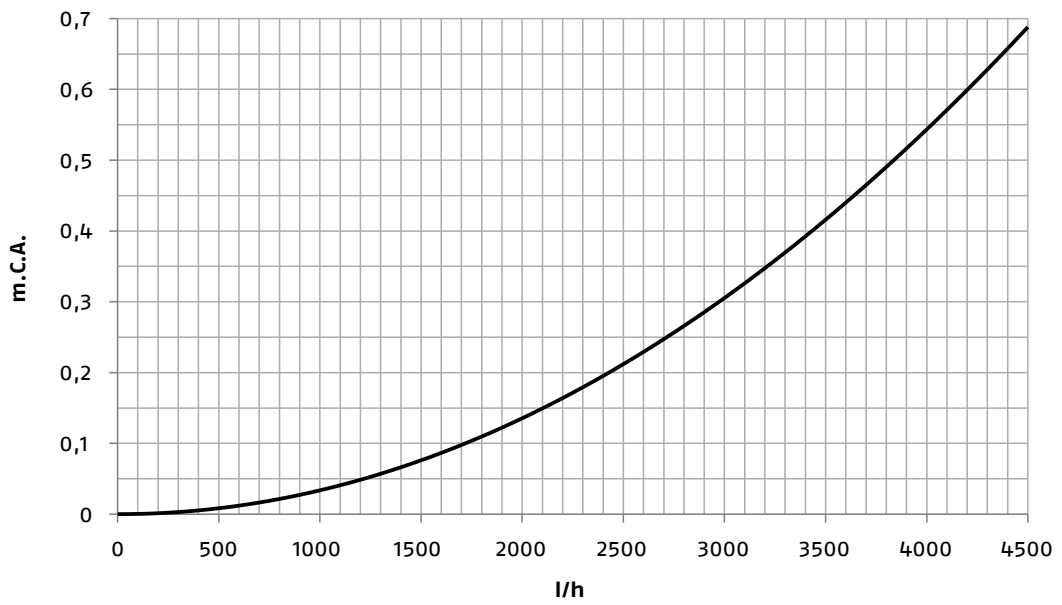

DIVERTER VALVE

3-way motorised full bore ball diverter valve for automatic diversion of the heat-transfer fluid distributed in air conditioning or DHW distribution systems.

Common fluid way: AB fluid passes on way A or on way B. G1" or G1 1/4" fittings available (ISO 228-1). CW617N brass body. CW617N brass ball, chrome-plated. Ball hydraulic seal in PTFE (Teflon®) with O-Ring in EPDM Perox TIMO. O-Ring in EPDM Perox TIMO. Motor casing in PA66 GF25 - UL94-V0. Usage fluids water and glycol solutions; maximum glycol percentage 50%. Nominal pressure 16 bar.

PN16. Maximum operating differential pressure 6 bar. Outflow coefficient, Kvs: 15.5. Fluid operating temperature range 2 - 90 °C.

Operating ambient temperature range 0 - 60 °C. Power supply 230 V (or 24 V); power input 7 W. Auxiliary micro contacts capacity 3 (1) A, 250 V.

Protection rating IP 40. Insulation class: II - Ref. European standard EN 60730.

Commutation time: 25 s.

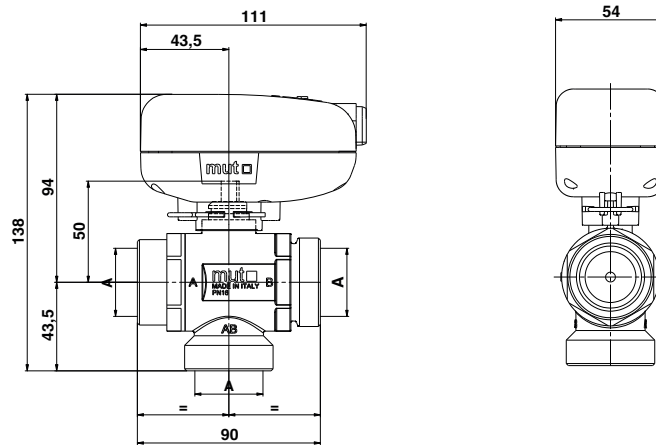

DIVERTER VALVE ASSEMBLY

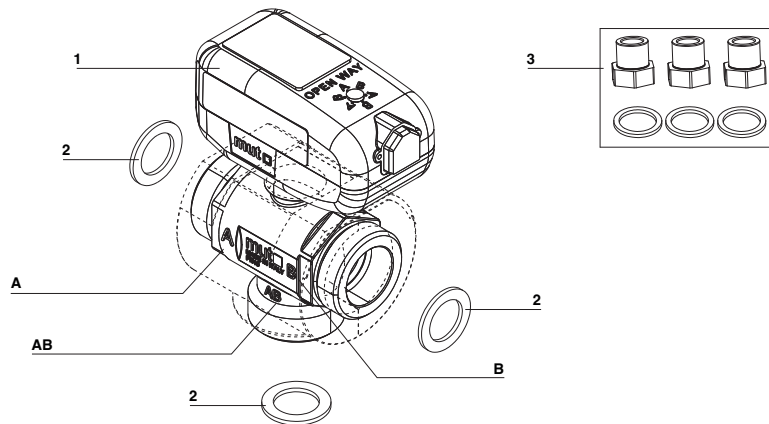

1. 3-way motorised ball diverter valve SPST 230 Vac-50/60 Hz - 1"1/4 M fitting
2. 1" flat gasket in Centellen
3. Unions for adapters 1" 1/4 F- 1" 1/4 F - 1" M and relative gaskets

ELECTRICAL CONNECTIONS

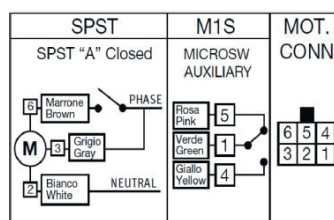

To connect the electricity, see the terminal board of the indoor unit

HEAT PUMPS

Split air-water heat pumps

FUNCTIONAL CHARACTERISTICS

- AB way always open
- Type of valve operation: diverter (on/off)
- Nominal pressure: PN16
- Max. differential pressure: 6bar
- Flow rate coefficient Kvs in diversion: 90° ([m³/h] at ΔP= 1bar): Kvs=15.5
- Fittings: Threaded – ISO 228/1
- Full bore valve (DN25)
- Fluid temperature limits: 2 ÷ 90 °C [max]
- Usage fluid: Water, glycol solutions [max 50%]
- Ambient temperature range: 0 – 60 °C
- Type of actuation: SPST = Single-pole external electr. comm. (with built-in relay)
- With 1 auxiliary micro as standard: 3(1)A – 250 Vac
- Insulation class: II Ref. European standard EN 60730
- Protection rating: IP 40 Ref. European standard IEC EN 60529
- Type of connector: Molex Mini-Fit JR 6 pole or compatible
- Cable length: 1000 mm
- Voltage: 230V or 24V
- Synchronous motor
- Electric power supply: 230V (±10%) – 50/60 Hz / 24V (±10%) – 50/60 Hz
- Power input: 7W(Max)
- Manoeuvre ON time: 25 s
- Manoeuvre OFF time: 25s

MATERIALS

- Valve body: Brass
- Control shaft: Brass
- Ball: Brass
- Seal rings: PTFE (Teflon®)
- O-Rings: EPDM Perox (TIMO®)
- Servomotor casing: PA66GF30 (ISO 1874-PA 66, GHR, 14-100, GF30)

LOAD LOSS GRAPH

Load losses do not vary substantially with the variation of the route travelled, nor with the variation of the direction of travel.

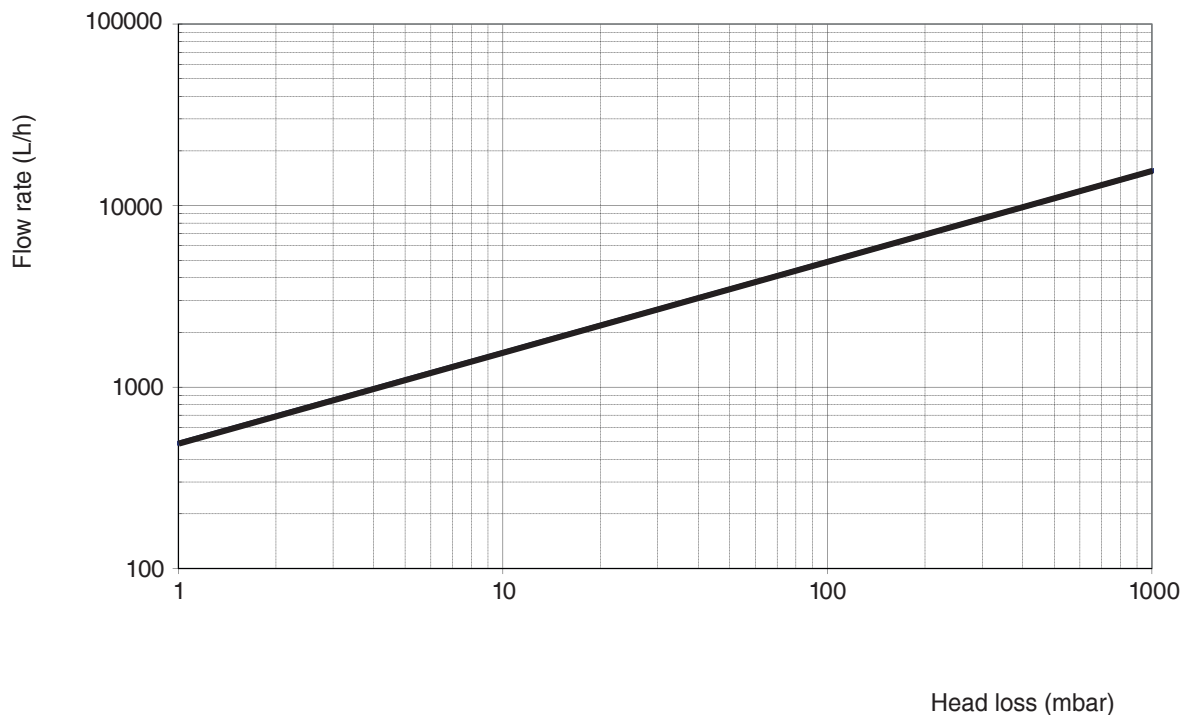

WATER FILTER Y 1"

DIMENSIONS

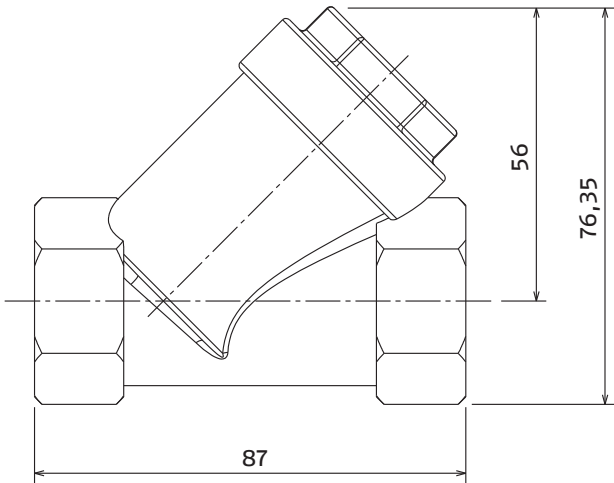

Y WATER FILTER ASSEMBLY

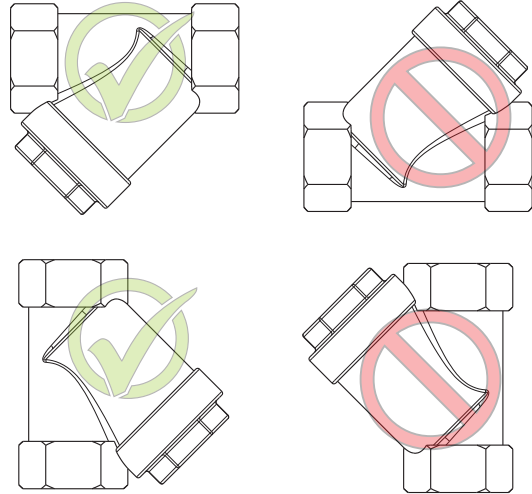

HEAD LOSS

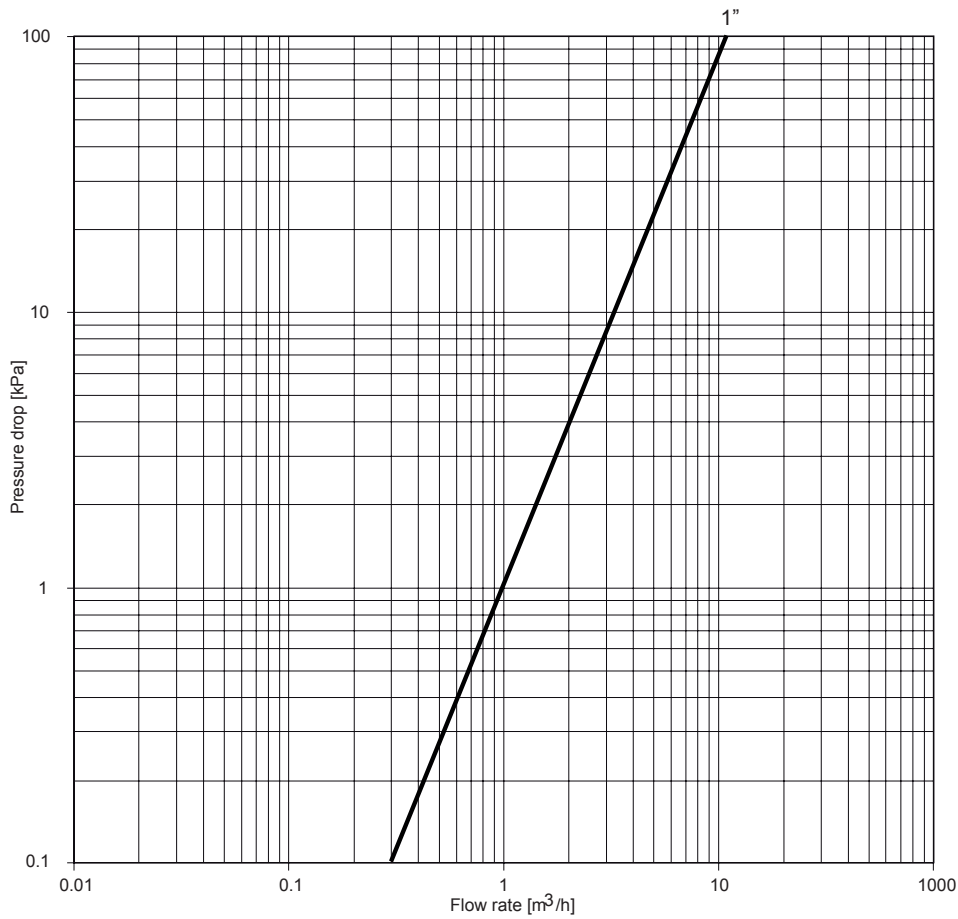

MEASUREMENT	Kv
1"	11

HEAT PUMPS

Split air-water heat pumps

Family Sprint

PRODUCT DESCRIPTION FOR SPECIFICATIONS

Single-phase or three-phase split air-water heat pump with DC-inverter control and MITSUBISHI twin rotary compressor for all sizes to guarantee optimum dynamic balancing and reduce vibration, with continuous modulation from approx. 40% to 120%, designed to work with R32 refrigerant gas.

Given the wide operating range, it's ideal for every type of system, whether hybrid or monovalent. In heating mode in fact, it can supply water at 60°C with an outdoor temperature as low as -15°C, and in cooling mode water at 7°C with an outdoor temperature up to 43°C. It can also produce domestic hot water thanks to storage tanks and fixed coils or heat exchangers for instantaneous DHW production, as it can supply delivery water at 55°C with an outdoor temperature of 43°C.

Top level performance. Up to A+++ for low temperatures and A++ for medium temperatures in temperate zones, according to EN 14825. All the performance values are certified by HP Keymark, MCS.

Built in accordance with the European eco-design regulations, which define the requirements for the ERP (Energy Related Products) standard in order to improve energy efficiency.

CHARACTERISTICS

- FAMILY SPRINT provides an extremely high level of energy efficiency in both heating and cooling mode, thereby guaranteeing significant energy savings. The large, high-efficiency coils, together with the optimised circuits, ensure results that meet the European tax relief requisites. Efficiency levels in part load conditions (seasonal energy efficiency) are the highest in this industrial sector.
- Comfort throughout the year: the ground-breaking technology of SPRINT means boosted comfort levels for users in terms of both water temperature control and quiet operation. The required temperature is reached quickly and kept constant, without any fluctuations. SPRINT offers optimised, personalised comfort levels both in winter and in summer.
- SPRINT can work in cooling mode even with low outdoor temperatures (from -5°C, and up to 43°C). To ensure the maximum comfort for the user, the units work in heating mode with outdoor temperatures down to -25°C, whereas in summer they can produce hot water up to 50°C for DHW applications, with the an outdoor temperature as high as 43°C.
- In the ambient comfort modes (both heating and cooling), weekly programming is a standard feature.
- In the DHW modes, weekly programming and an anti-legionella function - with thermal disinfection - are available as standard.
- A multitude of possible system layouts. Thanks to the sensors available as accessories, the unit can manage - for example - a solar system, one or two zones (one of them mixed) and DHW recirculation.
- USB port available for updating the electronic board software.
- A clean input is available, dedicated to smart grid functions.
- Operation guaranteed with at least 40lt of water in the system.

OUTDOOR UNIT COMPONENTS

• STRUCTURE

Cabinet made of sheet steel painted with neutral-coloured powders (RAL 7035) to enhance resistance to corrosion caused by atmospheric agents. All the panels are removable.

• COMPRESSOR:

The dual compressor protection shield for sound insulation further reduces sound levels.

Advanced technology ensuring optimum energy efficiency and characterised by high output levels in peak conditions and optimised efficiency at low and medium compressor speeds.

The SPRINT heat pump uses DC inverter technology that combines two electronic adjustment logics, pulse amplitude modulation (PAM) and pulse width modulation (PWM), to guarantee optimised compressor operation in all working conditions, minimise temperature fluctuation and ensure perfect comfort adjustment whilst at the same time considerably reducing energy consumption.

- PAM: modulation of the direct current pulse amplitude makes the compressor work in maximum load conditions (start-up and peak load) so as to increase the voltage in the case of a fixed frequency. The compressor works at high speed to quickly reach the required temperature.
- PWM: modulation of the direct current pulse width makes the compressor work in part load conditions, adapting the frequency in the case of a fixed voltage. The compressor speed is precisely adjusted and the system offers a high comfort level (no temperature fluctuations) in working conditions of outstanding efficiency.

The compressor frequency increases constantly until it reaches the maximum level. This ensures that there are no intensity peaks during the start-up phase, and also means a secure connection to the single-phase current supply even for high-output systems. This compressor start logic makes "soft start" starter devices unnecessary, while also guaranteeing that the maximum output is available immediately.

• EXTERNAL COIL:

The external coil is made of copper pipes and hydrophilic aluminium fins. This solution makes it easier for the water to move towards the bottom of the heat exchanger, by means of gravity.

In particular, this innovation means:

- frost takes longer to form, so it does not build up so much on the coil;
 - the defrosting phase is more efficient thanks to improved water runoff on the fins which boosts operation in heating mode.
- Blue Coating treatment is applied as standard to improve the resistance of the coils to corrosive agents, and is recommended in all applications where there is a moderate risk of corrosion.

• EXTERNAL FAN:

Single DC brushless fan motor with variable speed for optimum air distribution and extremely low noise levels. Two different maximum noise levels can be set.

• ELECTRONIC EXPANSION VALVE:

The electronic expansion valve is a dual-flow electronic expansion device whose job is to optimise the volume of the refrigerant fluid in the circuit and therefore the overheating issue, preventing the fluid from returning to the compressor. This device further boosts the high efficiency and reliability of the system as it enables it to work even with very low condensation

pressure values across the whole operating range.

- **SOLENOID VALVE:**

Given the wide operating range of the unit, the solenoid valve (fully managed by the unit itself) allows the compressor to work at optimum temperature levels at all times.

INDOOR UNIT COMPONENTS

- **HYDRONIC UNIT:**

The hydronic module is always installed and is supplied with a variable-speed circulation pump, flow switch, 3 bar safety valve, 8-litre expansion vessel, and inlet and outlet water temperature probes.

A version with an electric backup heater as standard is also available.

All the internal hydronic parts are insulated to reduce heat loss. The anti-freeze program contains special functions that use the heat pump and backup heater (if installed) to protect the whole system from the risk of freezing. When the water flow temperature in the system falls to a certain value, the unit heats the water using both the heat pump and the electric heating cock (and also the backup heater, if installed). The anti-freeze protection function is only deactivated when the temperature rises to a certain value.

- **PLATE HEAT EXCHANGER:**

Vertical plate heat exchanger in AISI 316 stainless steel.

- **CONTROL PANEL designed for:**

Full control and supervision of refrigerant circuit

Management of compressor and fans modulation signal

Signalling of faults

Management of external coil defrosting

Logic management of internal plate heat exchanger heat dissipation and anti-freeze

Management of ambient heating functions, DHW production (with anti-legionella functions), ambient cooling

Primary circulator management

Management of 3-way valve for DHW production (optional)

External sensor management

Management of backup heating elements (solely for versions with heating element).

RIELLO

RIELLO S.p.A. -
37045 Legnago (VR) Italy
tel. +39 0442 630111

www.riello.com



The company is constantly working to perfect the features of its entire production range so the design and size, technical data, equipment and accessories may be subject to change.



©2026 Carrier. All Rights Reserved.
All trademarks and service marks referred herein
are property of their respective owners.