

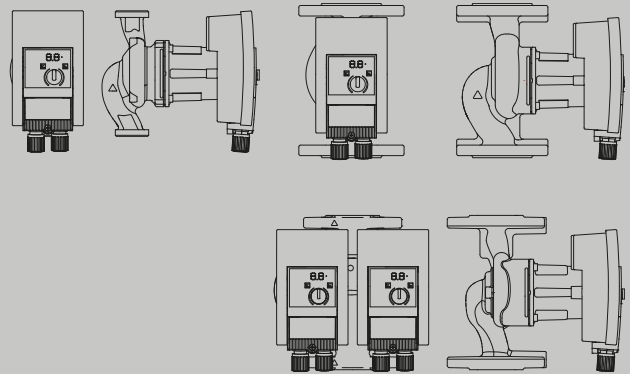

VegA RSHE – VegA RTHE

Water circulators

Single and twin electronic circulators - ErP Ready



Vega RSHE – Vega RTHE

PRODUCT DESCRIPTION

Electronic wet rotor circulators with high-efficiency motor, ensuring top performance and energy savings linked to the electronic control system which allows to vary the working speed of the rotor ensuring the correct supply requested by the system. The differential pressure can be set as constant or variable, or the three speeds can be selected manually.

Features:

- Low energy consumption.
- A LED indicator clearly shows the nominal discharge head, the speed stage and any possible errors.
- Easy setting of speed stages if the standard (non-adjusted) pump is replaced.
- Front access to the terminal board, for easy electrical wiring.
- Certainty regarding system availability, thanks to the cumulative lockout signal.
- Compact design and simple, tested use.
- Quiet operation.
- Pump body in a material that prevents condensate-induced corrosion.
- Power supply 230V and 50/60Hz.

Usage limits:

- Max. operating pressure: 10 bar.
- Temperature range: from -20°C to 110°C.
- Protection level: IP x4D.

IDENTIFICATION

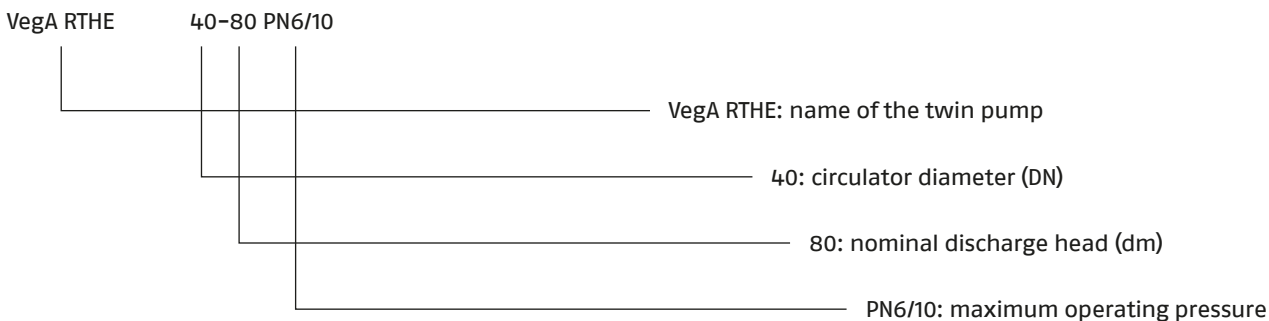
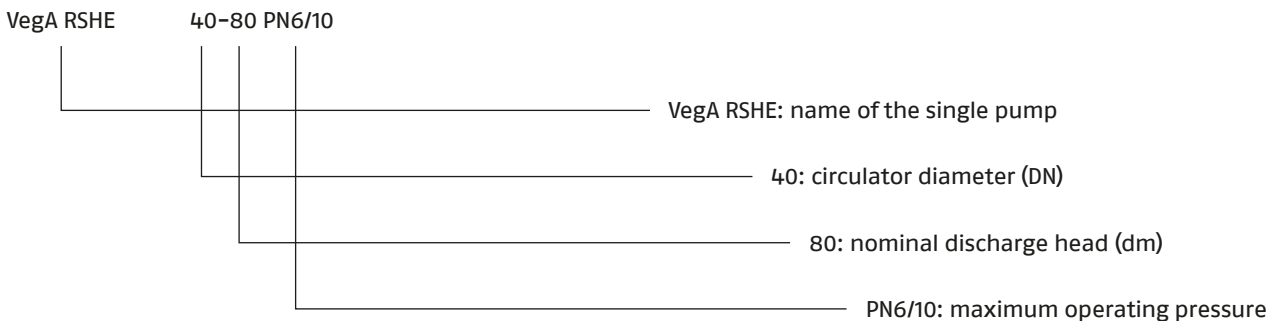

TECHNICAL DATA Vega RSHE

Model	UM	Vega RSHE (single circulators)							
		25-60	25-70	25-90	30-60	30-70	30-90	32-70	40-30
Max. water flow rate	m ³ /h	8,2	9,6	11,7	8,2	9,6	11,7	13,0	12,7
Max. discharge head	m w.c.	7,4	10,8	12,1	7,4	10,8	12,1	9,0	5,4
Max. operating pressure	bar	10,0	10,0	10,0	10,0	10,0	10,0	10,0	6,0/10,0
Min/max operating temperature (water)	°C	-20 / +110°C							
Max. operating temperature (ambient)	°C	-20 / +40°C (max. relative humidity = 95%)							
Electrical supply	V/Hz	230V ±10% / 50-60 Hz							
Nominal electric power	W	90	140	200	90	140	200	200	90
Min/max absorbed electrical power	W	5/120	5/190	10/305	5/120	5/190	10/305	10/305	7/120
Min/max absorbed current	A	0,08/1,00	0,08/1,30	0,15/1,33	0,08/1,00	0,08/1,30	0,15/1,33	0,15/1,33	0,09/1,00
Insulation class		F	F	F	F	F	F	F	F
Electrical protection level	IP	X4D	X4D	X4D	X4D	X4D	X4D	X4D	X4D
Weight	kg	4,5	4,5	5,3	4,6	4,6	5,4	9,0	8,6

Model	UM	Vega RSHE (single circulators)							
		40-60	40-80	50-70	50-80	65-80	65-90	65-110	80-90
Max. water flow rate	m ³ /h	18,2	24,8	29,0	31,2	32,0	46,2	55,5	64,0
Max. discharge head	m w.c.	8,5	13,0	10,2	12,8	10,1	11,6	17,1	13,5
Max. operating pressure	bar	6,0/10,0	6,0/10,0	6,0/10,0	6,0/10,0	6,0/10,0	6,0/10,0	6,0/10,0	6,0
Min/max operating temperature (water)	°C	-20 / +110°C							
Max. operating temperature (ambient)	°C	-20 / +40°C (max. relative humidity = 95%)							
Electrical supply	V/Hz	230V ±10% / 50-60 Hz							
Nominal electric power	W	200	450	400	500	500	650	1200	1,300
Min/max absorbed electrical power	W	10/305	15/550	15/490	15/600	15/600	40/800	40/1450	40/1550
Min/max absorbed current	A	0,15/1,33	0,17/2,40	0,17/2,15	0,17/2,65	0,17/2,65	0,30/3,50	0,30/6,40	0,30/6,80
Insulation class		F	F	F	F	F	F	F	F
Electrical protection level	IP	X4D	X4D	X4D	X4D	X4D	X4D	X4D	X4D
Weight	kg	9,2	13,0	14,2	14,2	16,1	25,8	27,5	30,4

TECHNICAL DATA Vega RTHE

Model	UM	Vega RTHE (twin circulators)									
		32-60	32-80	40-60	40-80	50-70	50-80	50-110	65-90	80-90	80-90
Max. water flow rate (*)	m ³ /h	7,9	13,3	17,5	22,0	26,4	26,0	39,0	43,0	61,0	61,0
Max. discharge head	m w.c.	7,6	9,2	8,0	12,3	9,6	12,1	16,4	11,5	13,0	13,0
Max. operating pressure	bar	6,0/10,0	6,0/10,0	6,0/10,0	6,0/10,0	6,0/10,0	6,0/10,0	6,0/10,0	6,0/10,0	6,0	10,0
Min/max operating temperature (water)	°C	-20 / +110°C									
Max. operating temperature (ambient)	°C	-20 / +40°C (max. relative humidity = 95%)									
Electrical supply	V/Hz	230V ±10% / 50-60 Hz									
Nominal electric power	W	90	200	200	450	400	500	1050	650	1,300	1,300
Min/max absorbed electrical power	W	5/120	10/305	10/305	15/550	15/490	15/600	40/1250	40/800	40/1550	40/1550
Min/max absorbed current	A	0,08/1,00	0,15/1,33	0,15/1,33	0,17/2,40	0,17/2,15	0,17/2,65	0,30/5,50	0,30/3,50	0,30/6,80	0,30/6,80
Insulation class		F	F	F	F	F	F	F	F	F	F
Electrical protection level	IP	X4D	X4D	X4D	X4D	X4D	X4D	X4D	X4D	X4D	X4D
Weight	kg	10,4	17,1	17,5	24,0	26,4	26,0	47,2	50,7	56,6	56,6

* For single circulator operation.

SYSTEM ACCESSORIES

Water circulators

ENERGY EFFICIENCY INDEX - VegA RSHE (single) - VegA RTHE (twin)

VegA RSHE (single circulators)	UM	25-60	25-70	25-90	30-60	30-70	30-90	32-70	40-30
Energy efficiency index	EEl	< 0,20	< 0,20	< 0,20	< 0,20	< 0,20	< 0,20	< 0,20	< 0,20

VegA RSHE (single circulators)	UM	40-60	40-80	50-70	50-80	65-80	65-90	65-110	80-90
Energy efficiency index	EEl	< 0,20	< 0,20	< 0,20	< 0,20	< 0,20	< 0,20	< 0,20	< 0,20

VegA RTHE (twin circulators)	UM	32-60	32-80	40-60	40-80	50-70	50-80	50-110	65-90	80-90
Energy efficiency index	EEl	< 0,23	< 0,23	< 0,23	< 0,23	< 0,23	< 0,23	< 0,23	< 0,23	< 0,23

MINIMUM POWER SUPPLY PRESSURE

The minimum pressure level to be guaranteed on the pump suction inlet, to avoid the risk of cavitation (at the working fluid temperature shown in the table).

NOMINAL DIAMETER	UM	Working fluid temperature		
		-20 - +50°C	+50 - +95°C	+95 - +110°C
Rp 1"	bar			
Rp 1" 1/4	bar	0,3	1,0	1,6
DN32	bar			
DN 40	bar			
DN 50	bar	0,5	1,2	1,8
DN 65	bar			
DN 80	bar	0,7	1,5	2,3

These values are valid up to 300 m a.s.l. A supplement must be added at higher levels: 0,01 bar for every 100 m increase in height. Adjust the values as necessary in the case of a higher fluid temperature, fluids pumped at low density, high flow resistance or low air pressure. The maximum installation altitude is 2000 metres a.s.l.

OPERATING PRINCIPLE

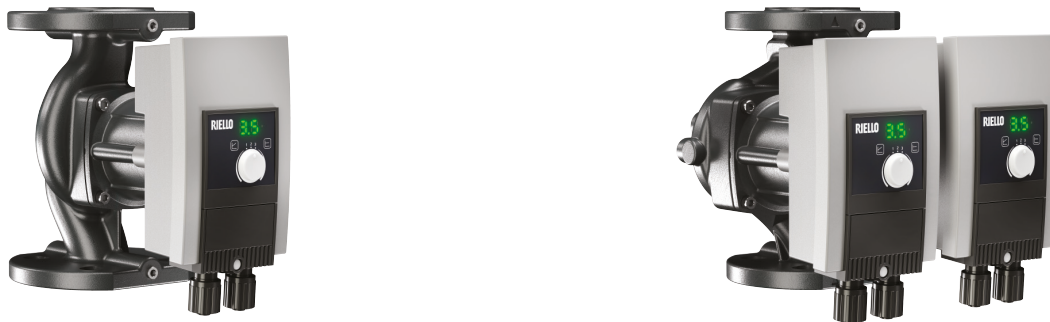

DESCRIPTION

VegA RSHE and VegA RTHE are wet rotor circulation pumps with a pipe union or flange connection, an EC motor and automatic operation adaptation. They are ideal for all heating systems, air-conditioning systems, closed refrigeration circuits and industrial circulation systems. These pumps are fitted with a LED indicator that shows the nominal pump discharge head, the speed stage (if the 3-speed operating mode is selected) and the error codes. The electrical wiring includes terminals for the power supply and the cumulative lockout signal.

OPERATING MODES

- Δp -c = for constant differential pressure
- Δp -v = for variable differential pressure
- n = constant (3 speed stages)

MANUAL FUNCTIONS

- Operating mode setting
- Pump operation setting (discharge head)
- Speed stage setting

AUTOMATIC FUNCTIONS

SINGLE PUMP VegA RSHE

- Modulating adaptation of output on the basis of the operating mode
- Release function
- Soft start-up
- Complete motor protection

TWIN PUMP VegA RTHE

- Modulating adaptation of output on the basis of the operating mode
- Release function
- Soft start-up
- Complete motor protection
- Twin pump function
- Main/reserve operation: for the automatic switchover of the pumps in the event of a lockout, a specific command appliance is required (to be obtained by the user)
- The pre-selected adjustment type and nominal discharge head must be the same on both pumps

ACCESSORIES

- Pipe unions for threaded connection (only for single models VegA RSHE)
- Counter-flange with flanged connection
- Compensation elements
- Communication module

SYSTEM ACCESSORIES

Water circulators

OVERALL DIMENSIONS

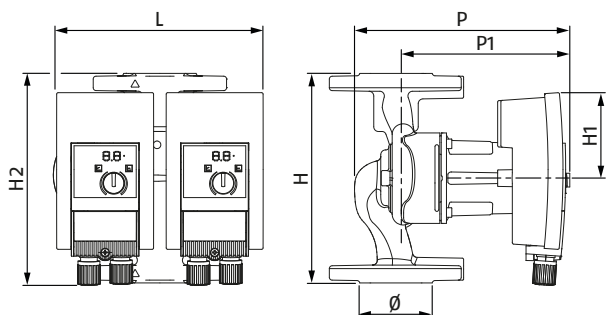
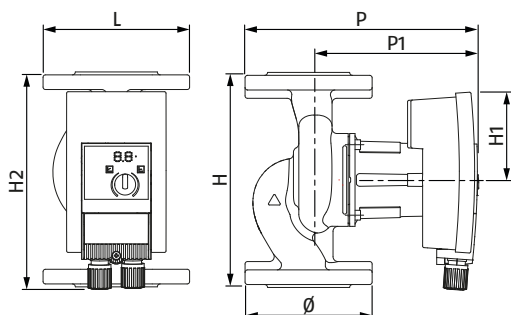
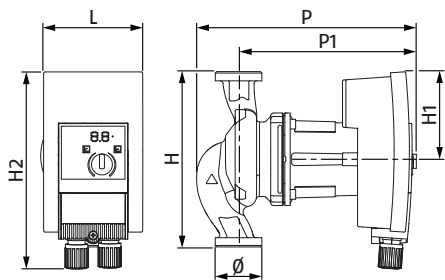

VegA RSHE	H mm	H1 mm	H2 mm	L mm	P mm	P1 mm	Ø mm	Weight kg
25-60 PN10	180	90	203	102	224	180	Rp 1" 1/2 (*)	4,5
25-70 PN10	180	90	203	102	224	180	Rp 1" 1/2 (*)	4,5
25-90 PN10	180	98	233	128	245	198	Rp 1" 1/2 (*)	5,3
30-60 PN10	180	90	203	102	224	180	Rp 2" (*)	4,6
30-70 PN10	180	90	203	102	224	180	Rp 2" (*)	4,6
30-90 PN10	180	98	233	128	245	198	Rp 2" (*)	5,4
32-70 PN6/10	220	98	233	128	255	207	DN32- PN6/10	11
40-30 PN6/10	220	90	223	102	232	175	DN40- PN6/10	8,6
40-60 PN6/10	220	98	245	128	249	201	DN40- PN6/10	9,2
40-80 PN6/10	250	109	277	142	379	315	DN40- PN6/10	13
50-70 PN6/10	280	109	292	142	371	318	DN50- PN6/10	14,2
50-80 PN6/10	280	109	292	142	371	318	DN50- PN6/10	14,2
65-80 PN6/10	280	109	292	142	384	327	DN65- PN6/10	16,1
65-90 PN6/10	340	169	340	174	404	334	DN65- PN6/10	25,8
65-110 PN6/10	340	169	340	174	395	329	DN65- PN6/10	27,5
80-90 PN10	360	169	360	174	414	330	DN80-PN10	30,4

VegA RTHE	H mm	H1 mm	H2 mm	L mm	P mm	P1 mm	Ø mm	Weight kg
32-60 PN6/10	220	110	223	231	240	180	DN32- PN6/10	10,4
32-80 PN6/10	220	110	245	251	321	364	DN32- PN6/10	17,1
40-60 PN6/10	220	110	245	269	330	266	DN40- PN6/10	17,5
40-80 PN6/10	250	125	277	302	388	326	DN40- PN6/10	24
50-70 PN6/10	280	140	292	310	392	330	DN50- PN6/10	26,4
50-80 PN6/10	280	140	292	310	392	330	DN50- PN6/10	26
50-110 PN6/10	340	170	340	398	385	315	DN50- PN6/10	47,2
65-90 PN6/10	340	170	340	406	422	334	DN65- PN6/10	50,7
80-90 PN6	360	170	360	456	439	339	DN80-PN6	56,6
80-90 PN10	360	170	360	456	439	339	DN80-PN10	56,6

HYDRAULIC PERFORMANCE Vega RSHE

Vega RSHE 25-60 PN10
Vega RSHE 30-60 PN10

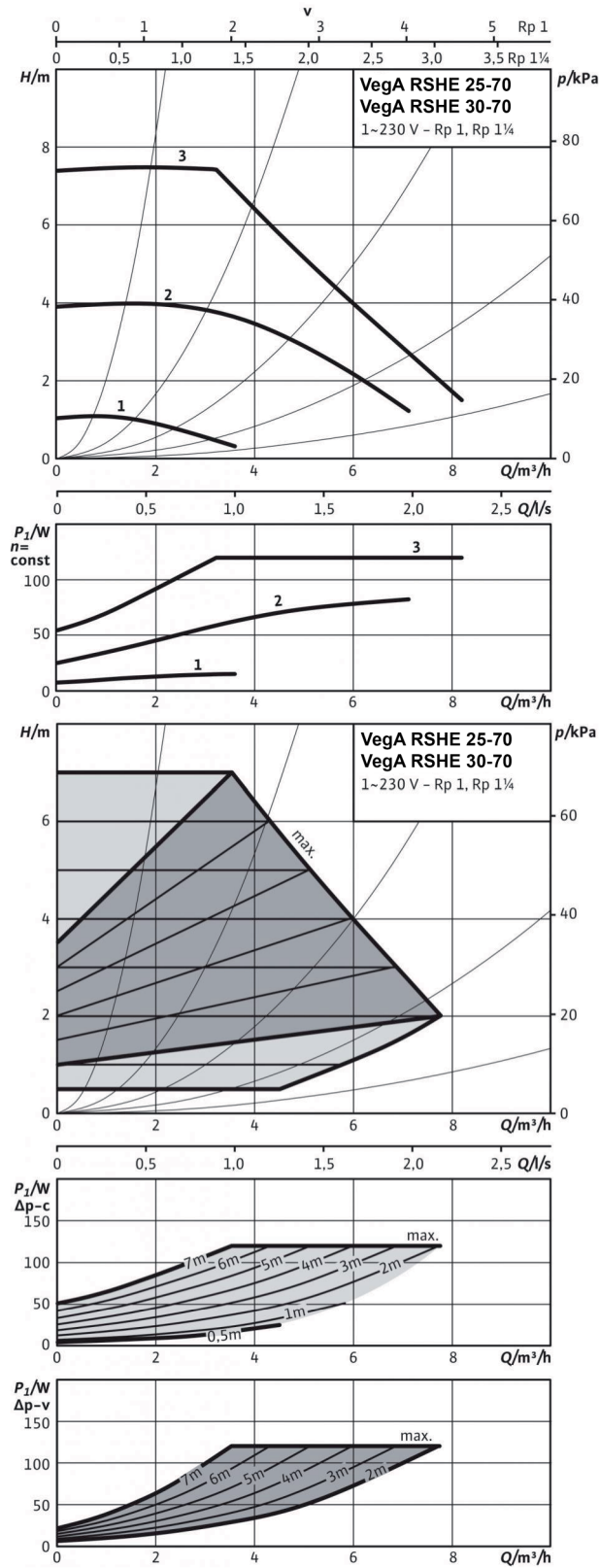

Vega RSHE 25-70 PN10
Vega RSHE 30-70 PN10

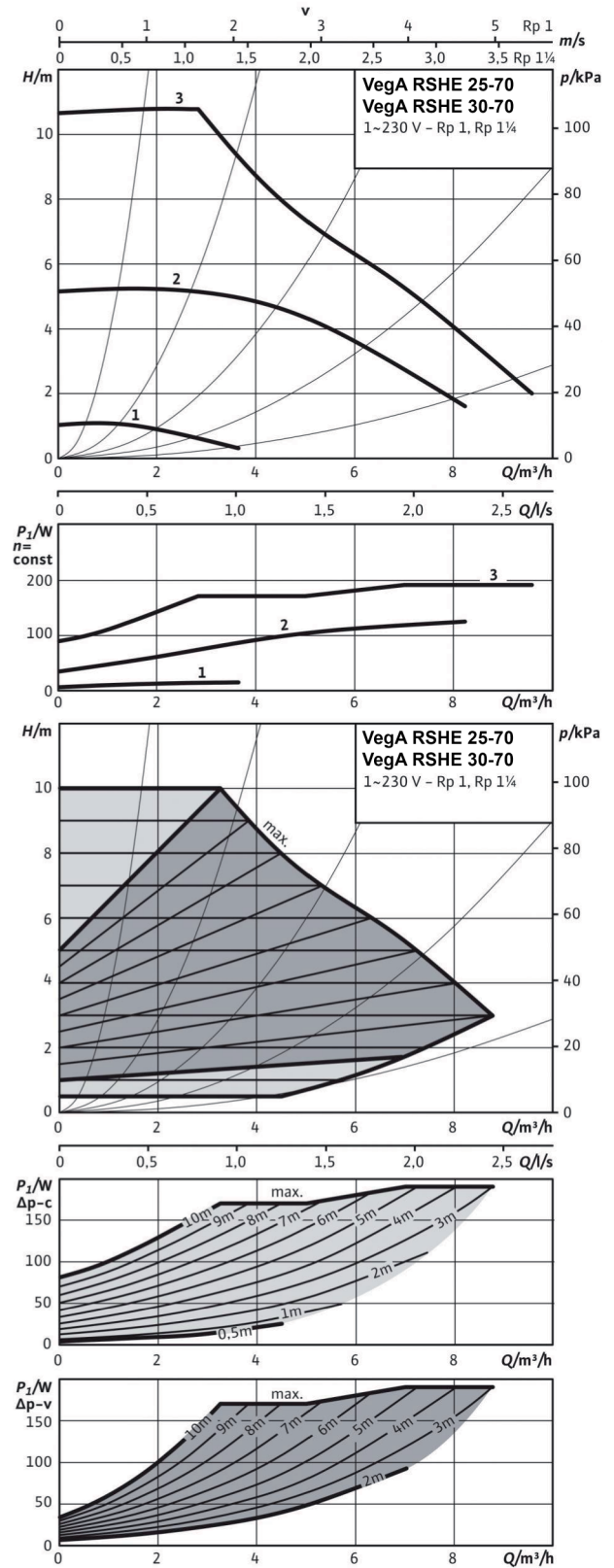

SYSTEM ACCESSORIES

Water circulators

VegA RSHE 25-90 PN10
VegA RSHE 30-90 PN10

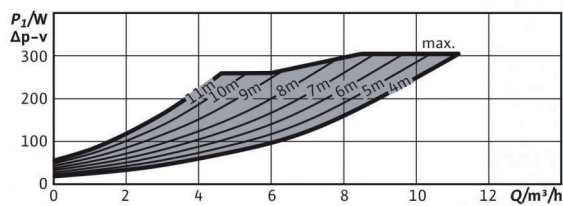
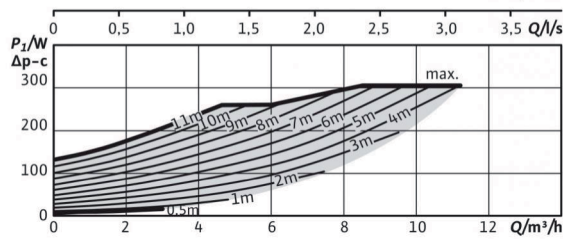
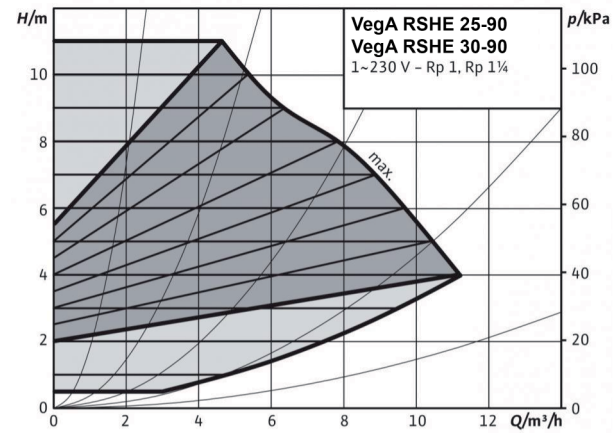
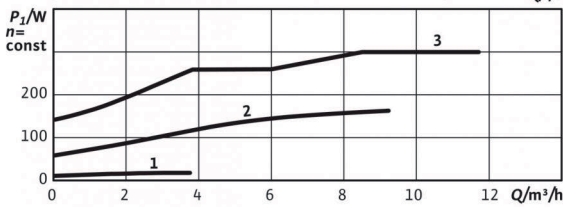
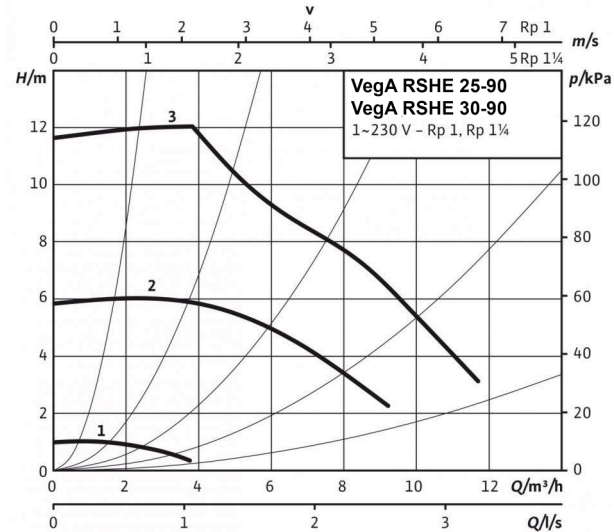

VegA RSHE 32-70 PN6/10

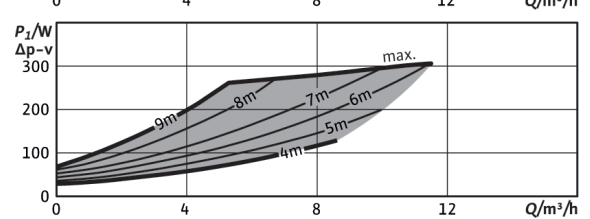
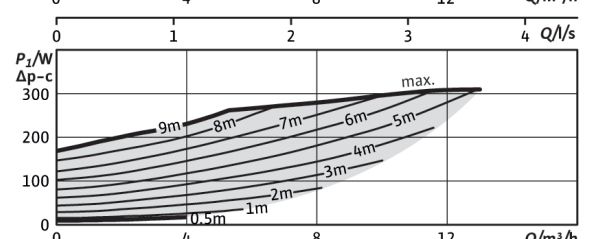
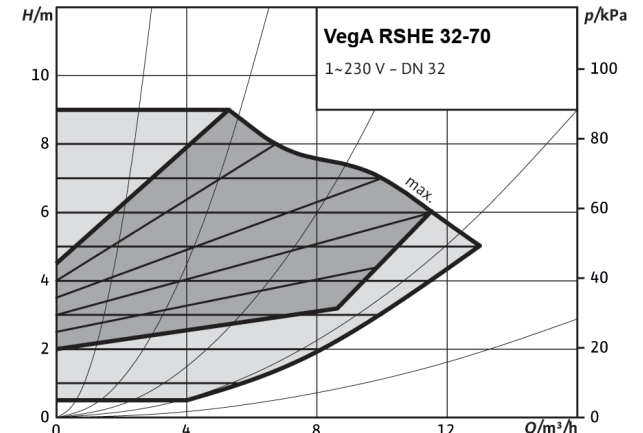
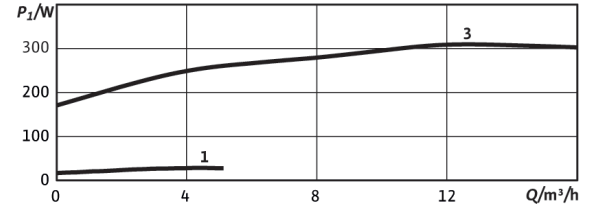
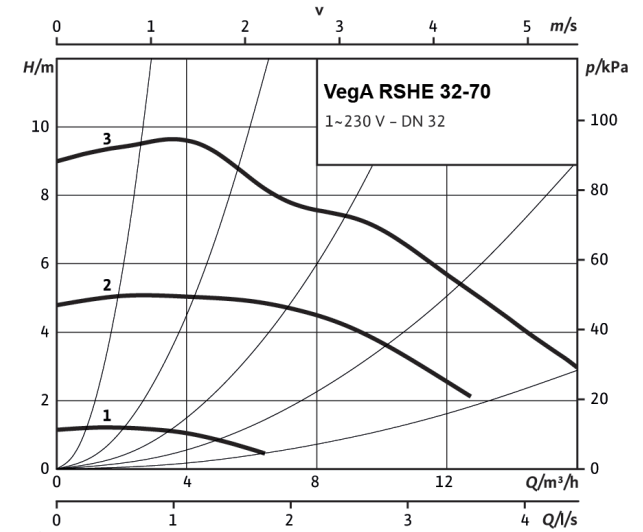

Vega RSHE 40-30 PN6/10

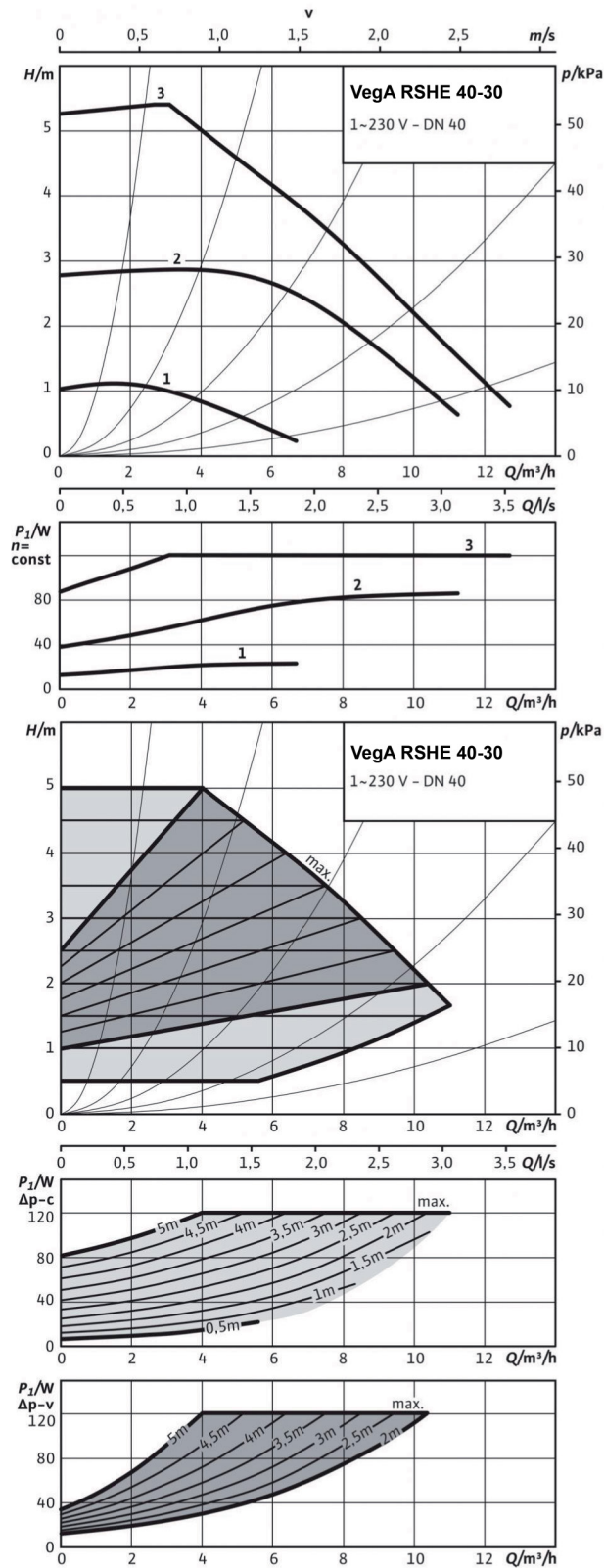

Vega RSHE 40-60 PN6/10

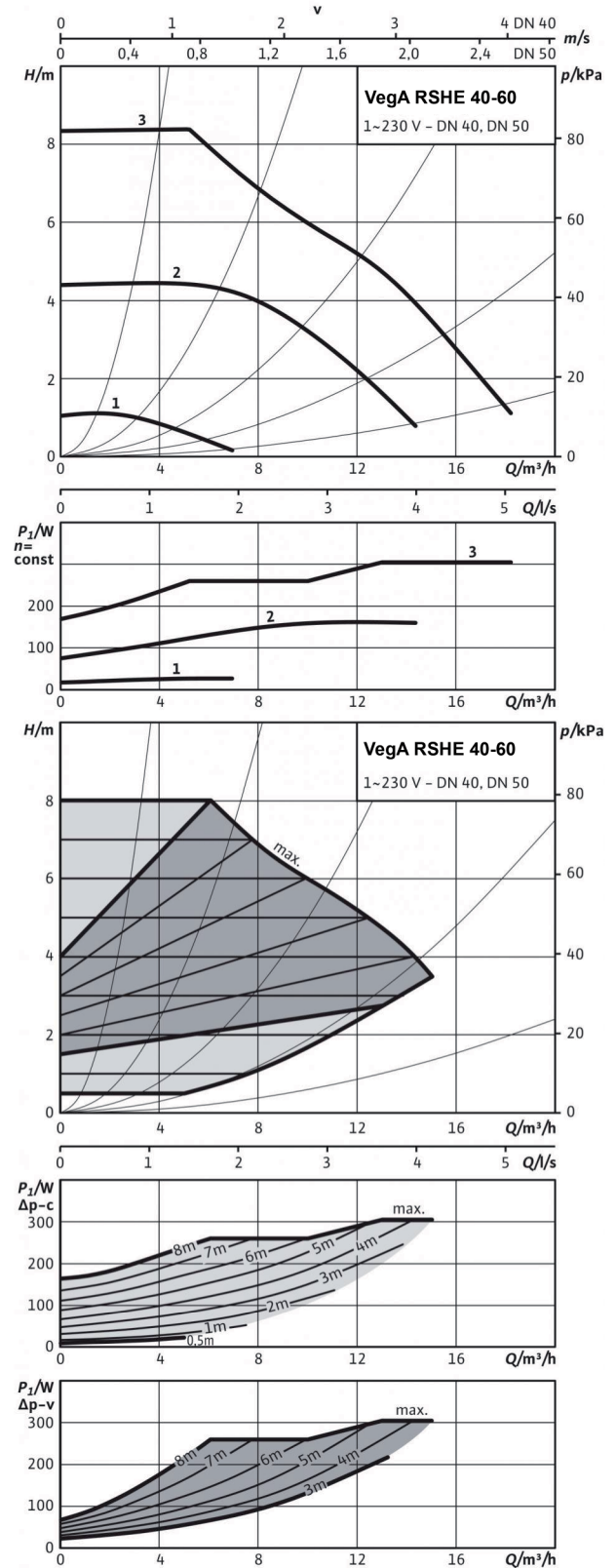

SYSTEM ACCESSORIES

Water circulators

Vega RSHE 40-80 PN6/10

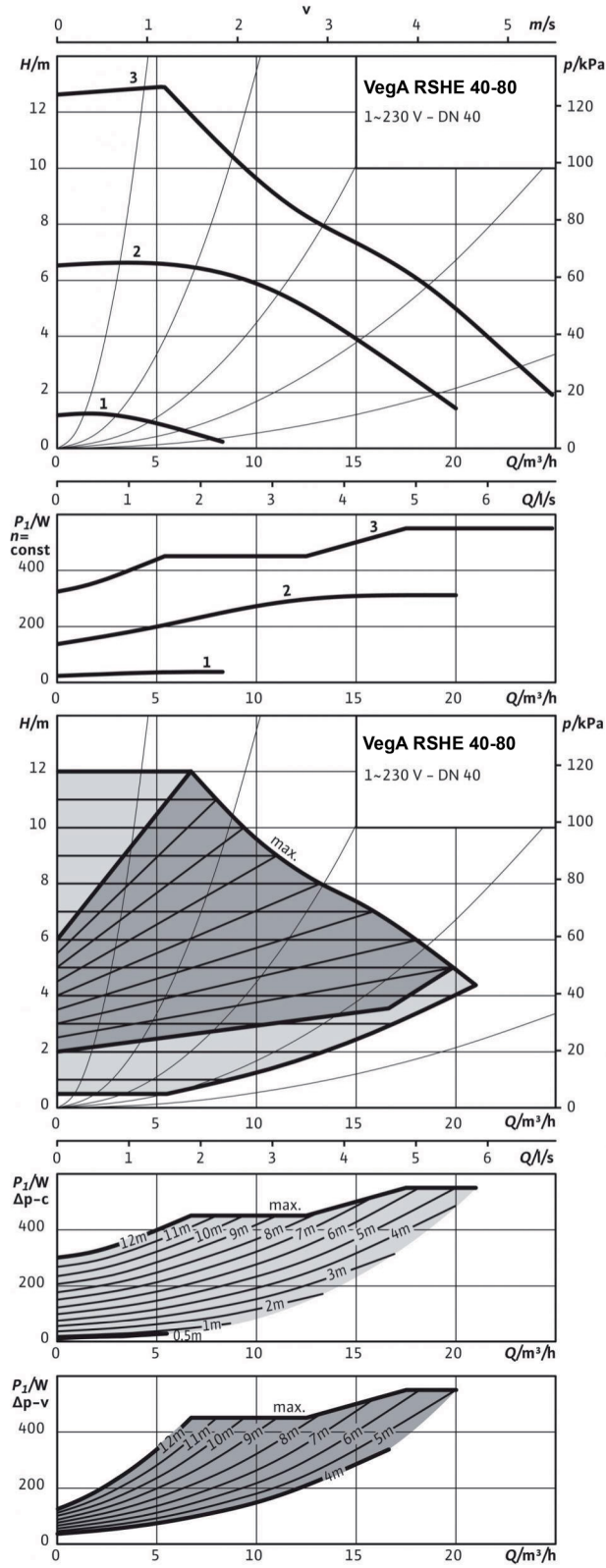

Vega RSHE 50-70 PN6/10

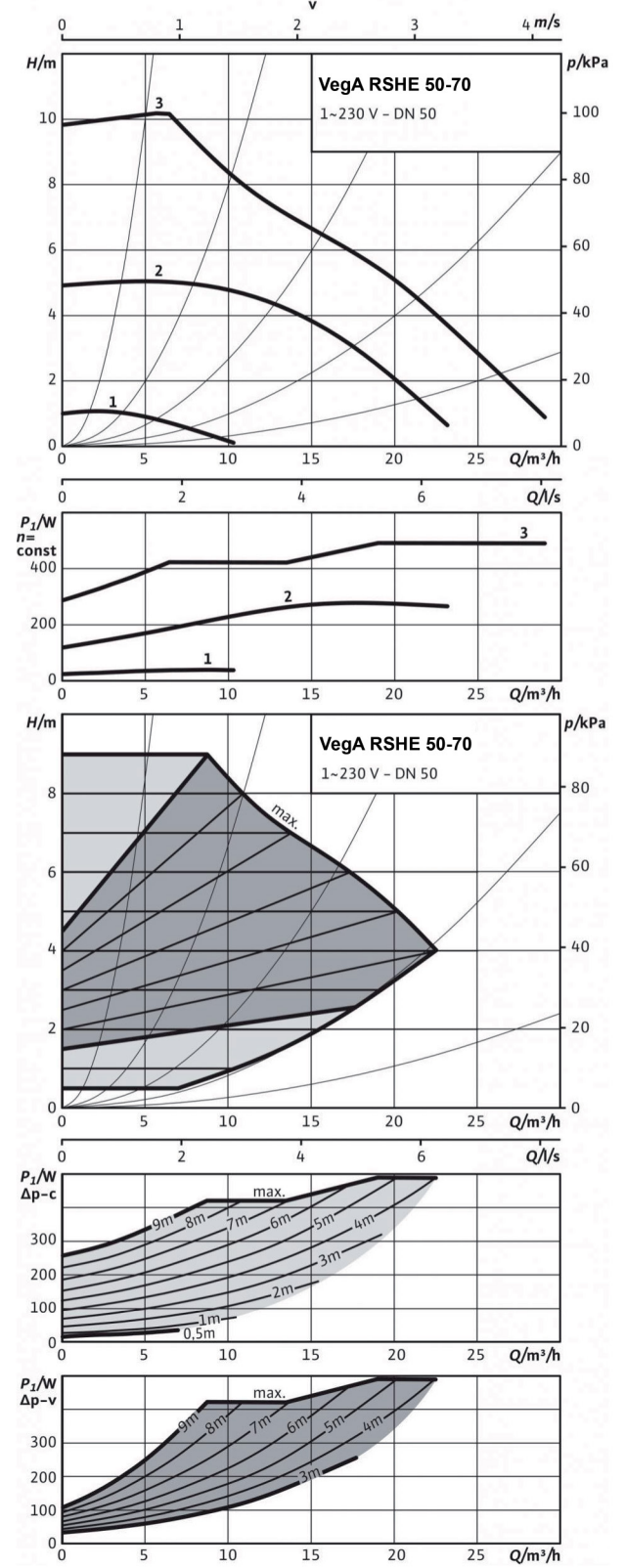

Vega RSHE 50-80 PN6/10

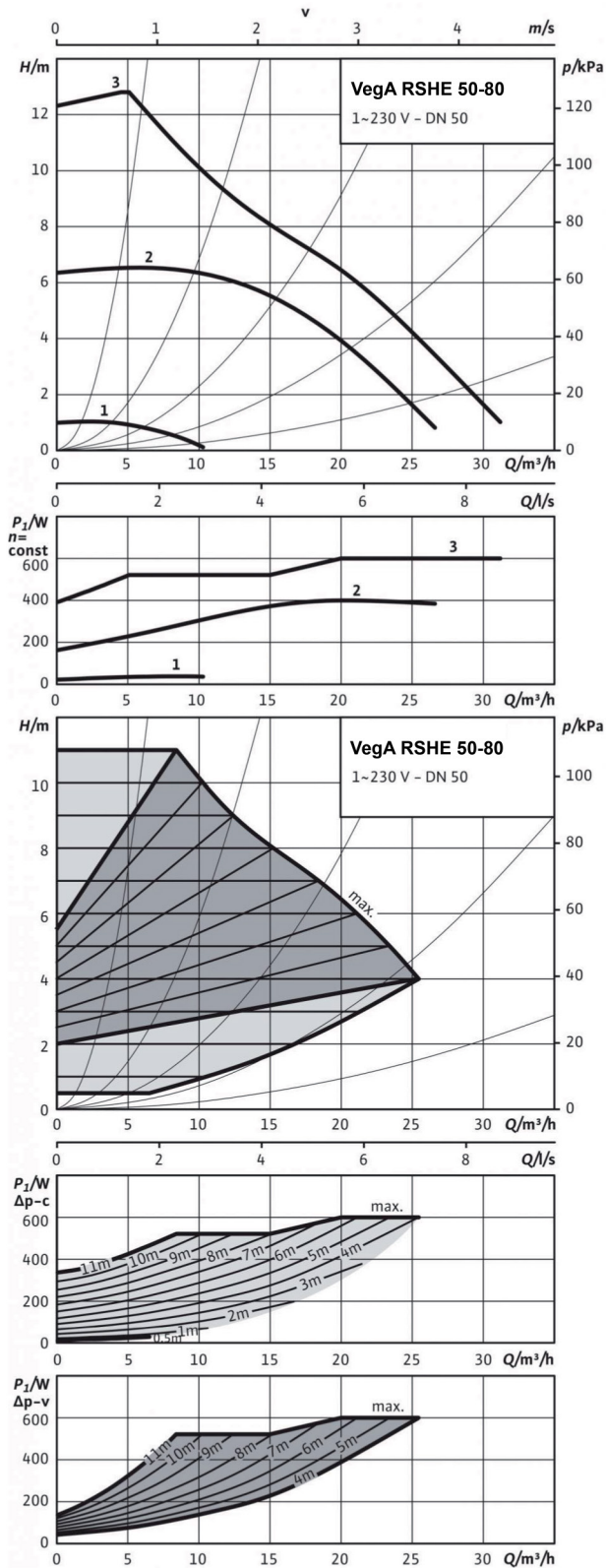

Vega RSHE 65-80 PN6/10

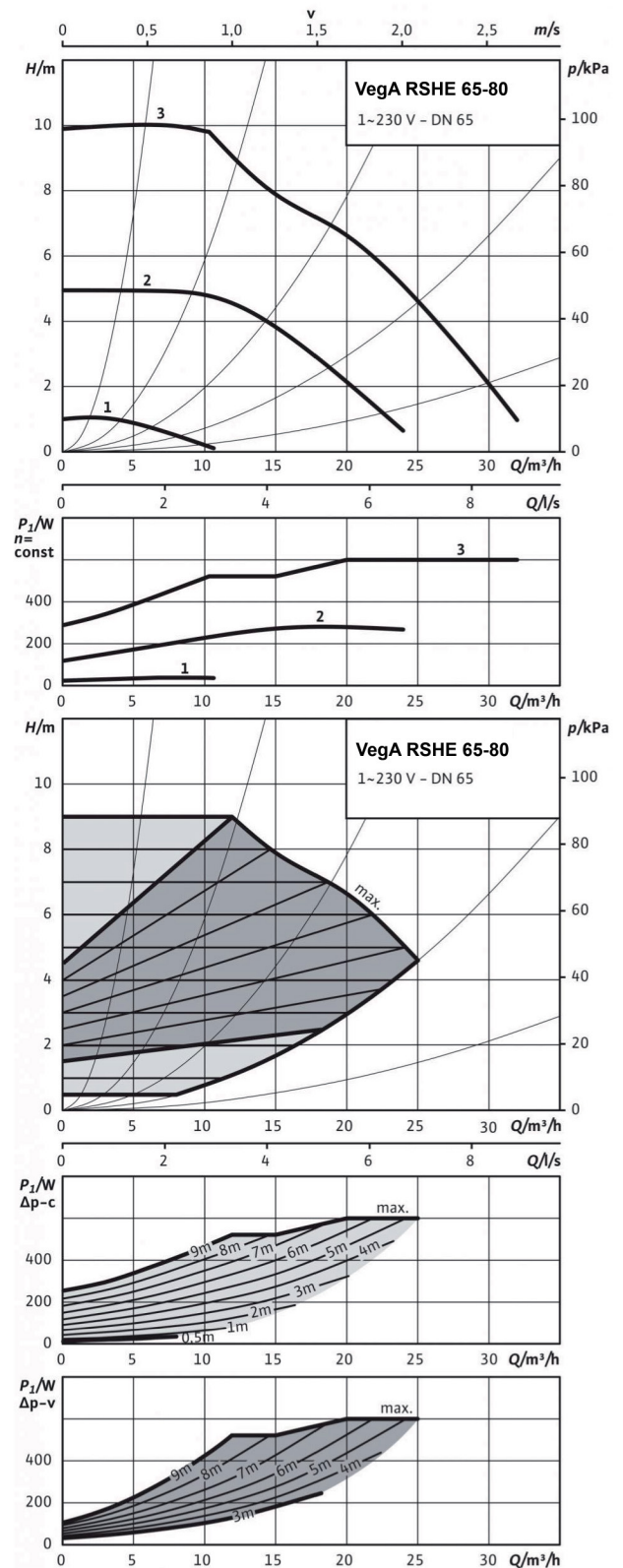

SYSTEM ACCESSORIES

Water circulators

Vega RSHE 65-90 PN6/10

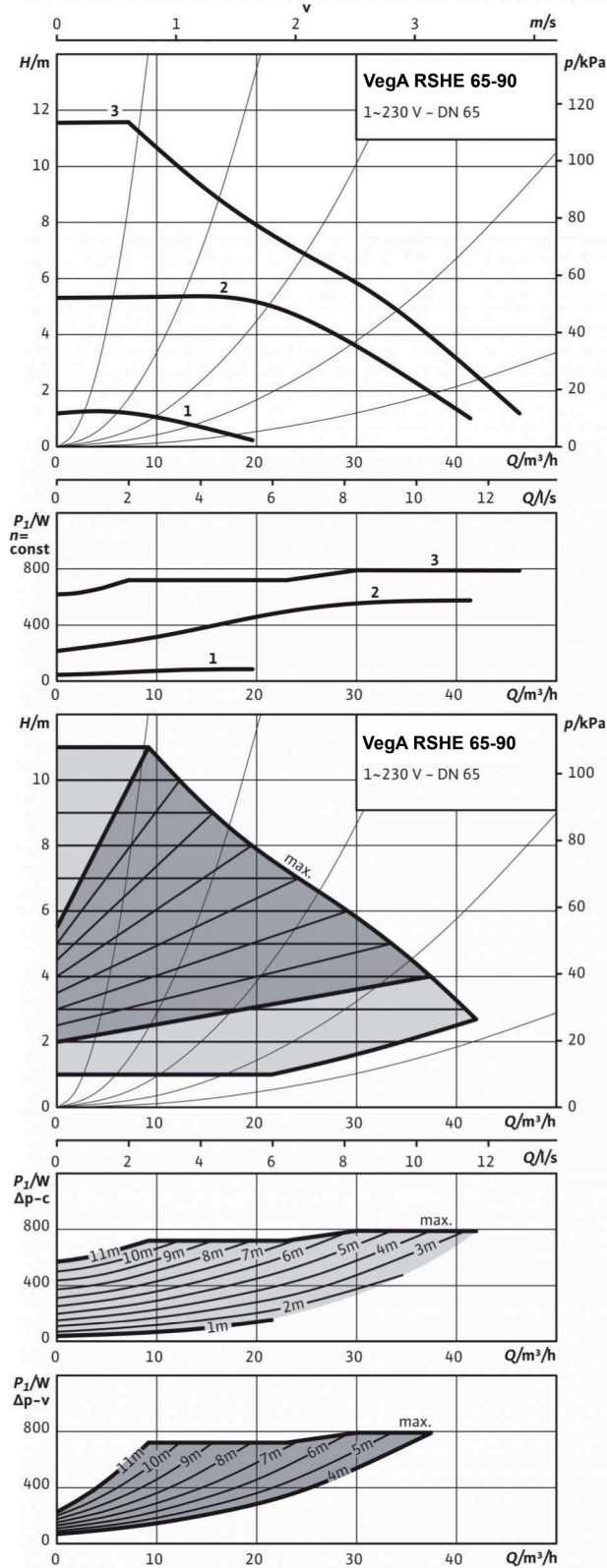

Vega RSHE 65-110 PN6/10

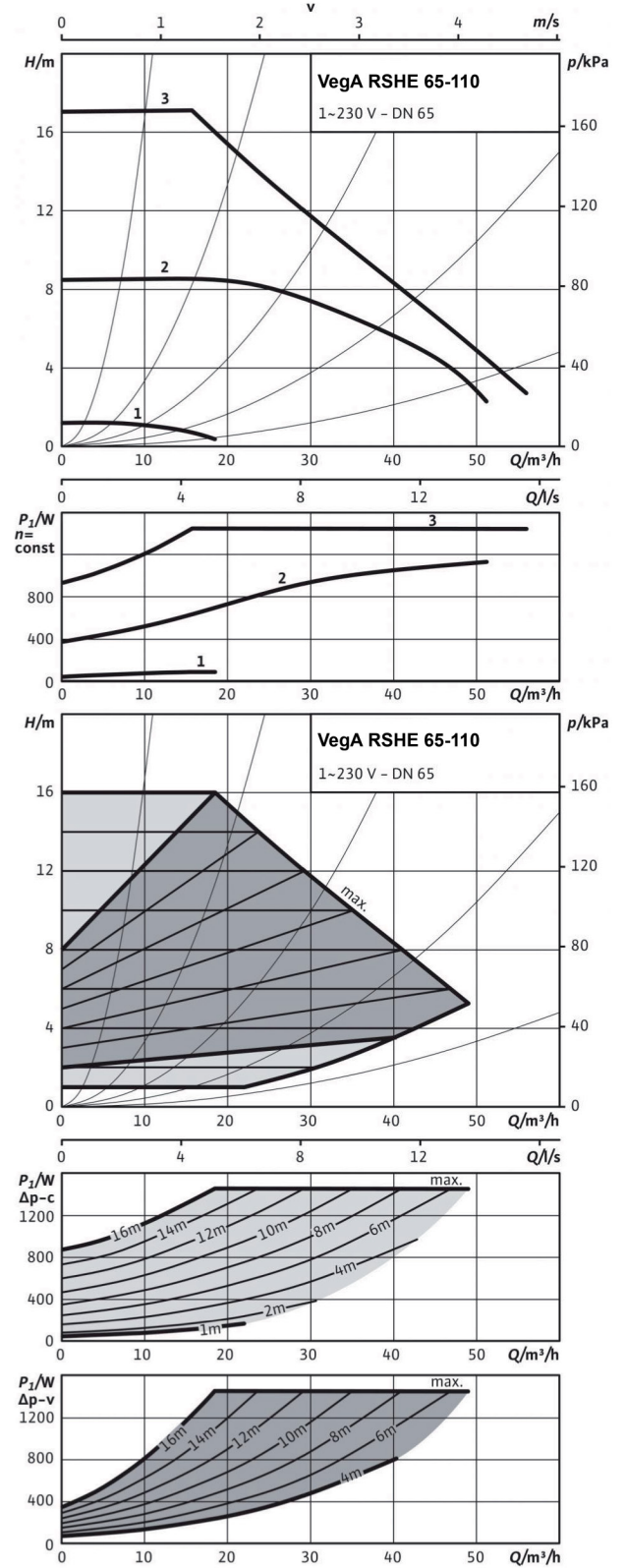

VegA RSHE 80-90 PN10

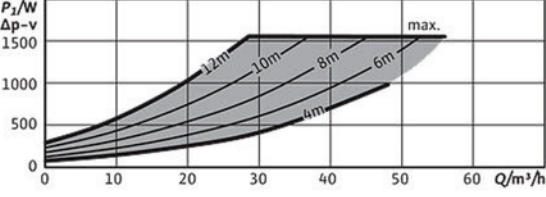
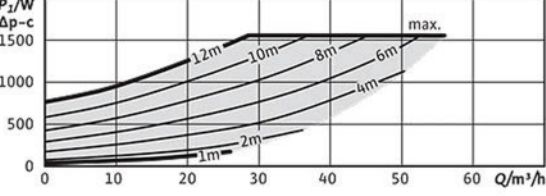
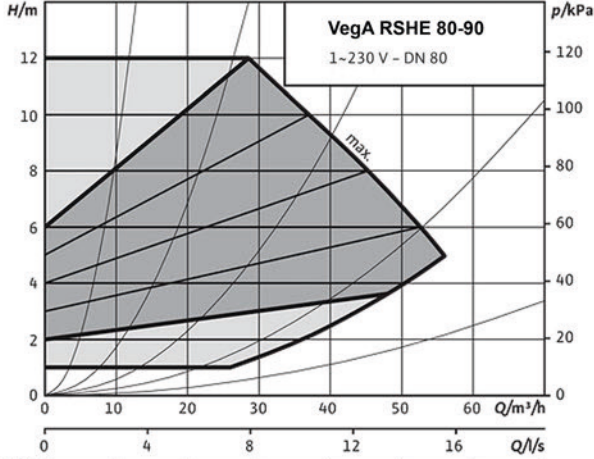
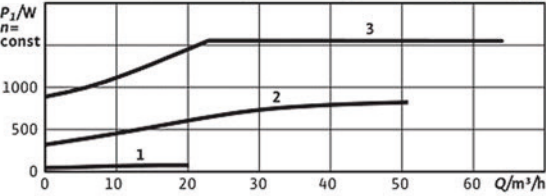
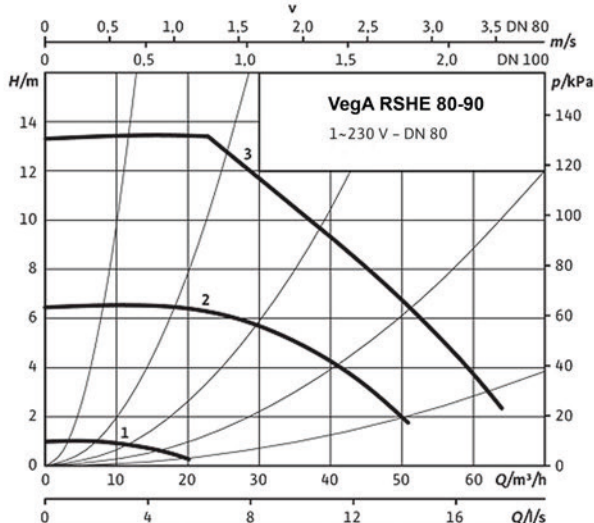

SYSTEM ACCESSORIES

Water circulators

HYDRAULIC PERFORMANCE VegA RTHE

VegA RTHE 32-60 PN6/10

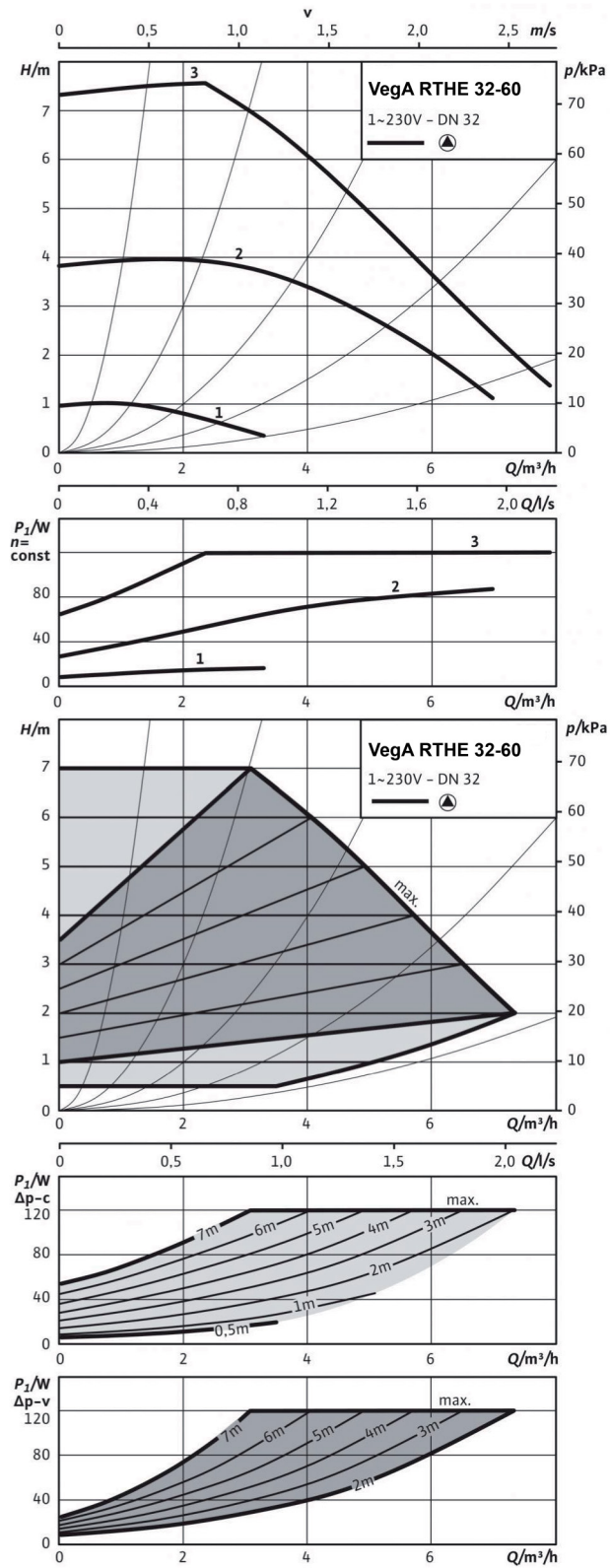

VegA RTHE 32-80 PN6/10

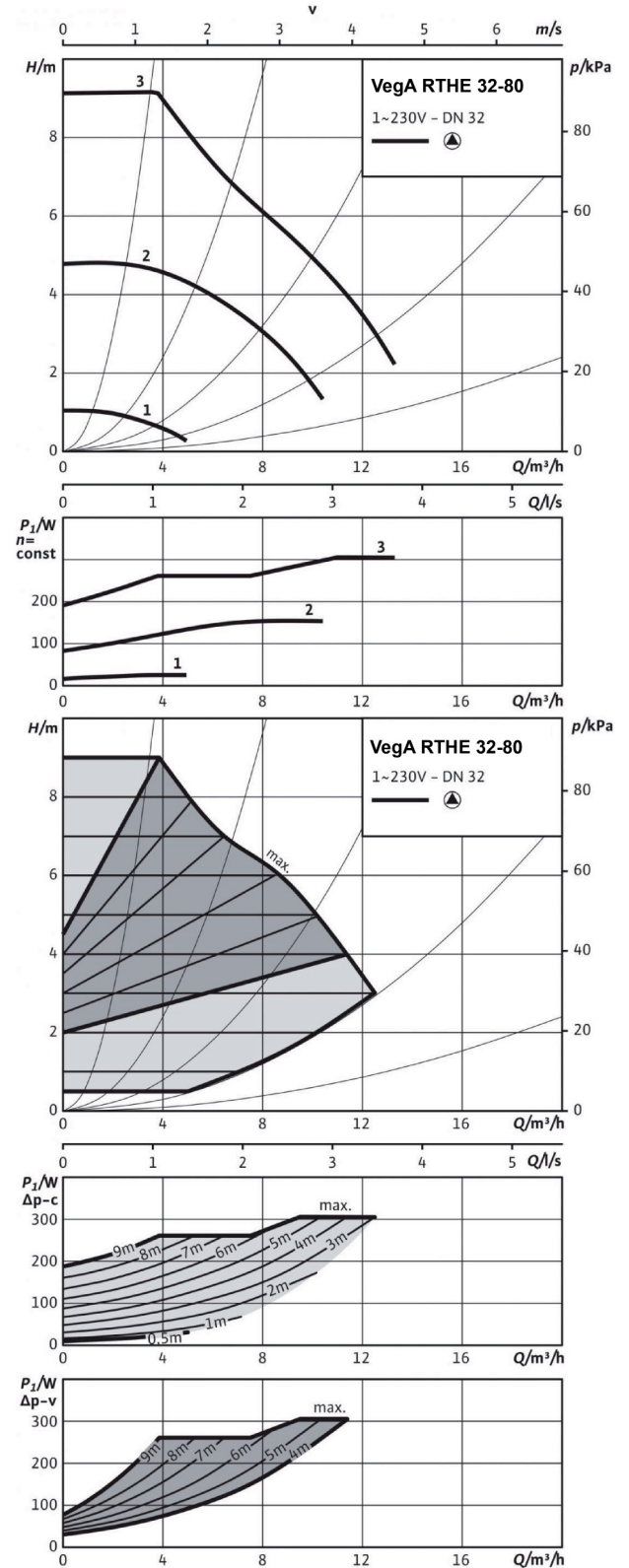

Vega RTHE 40-60 PN6/10

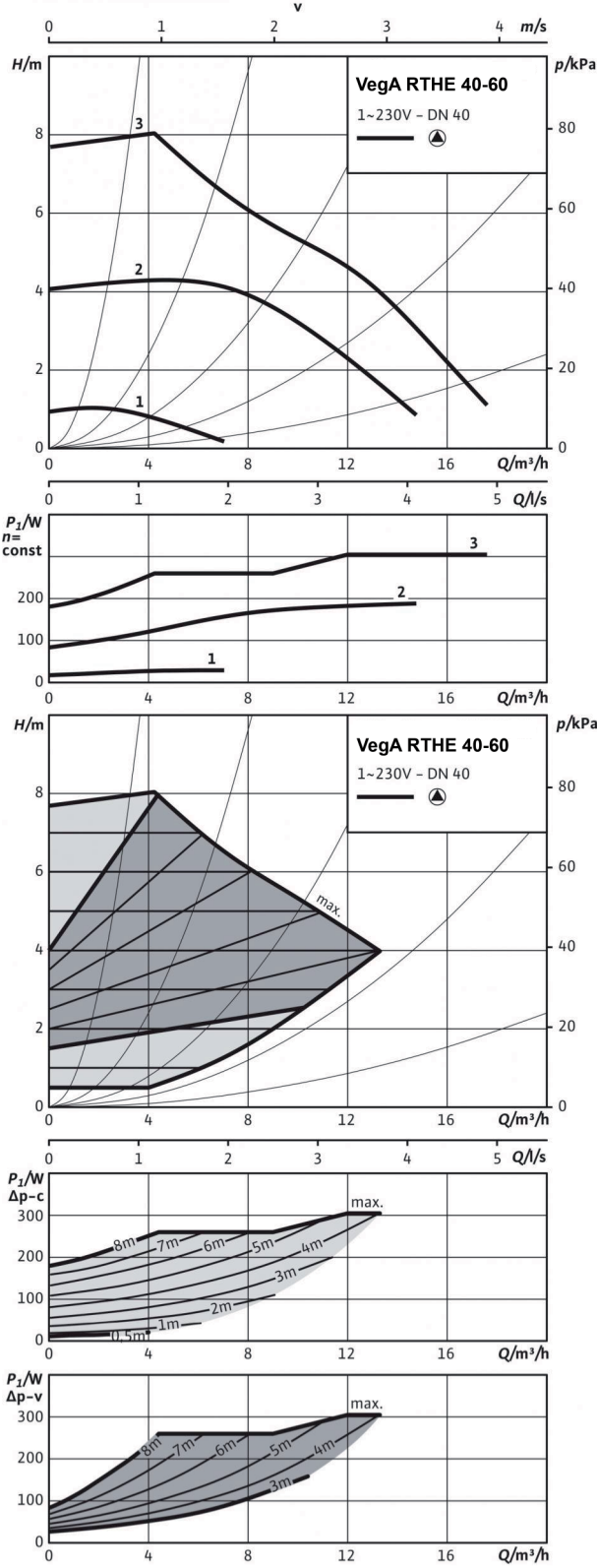

Vega RTHE 40-80 PN6/10

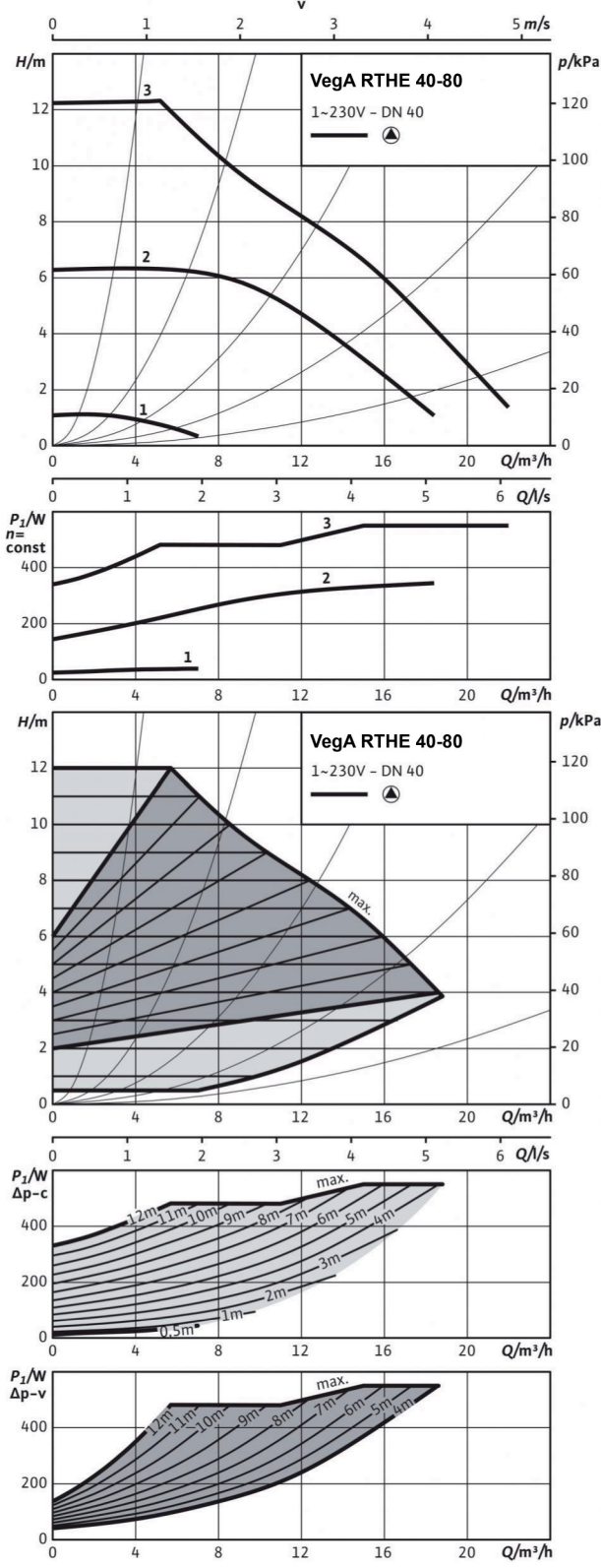

SYSTEM ACCESSORIES

Water circulators

Vega RTHE 50-70 PN6/10

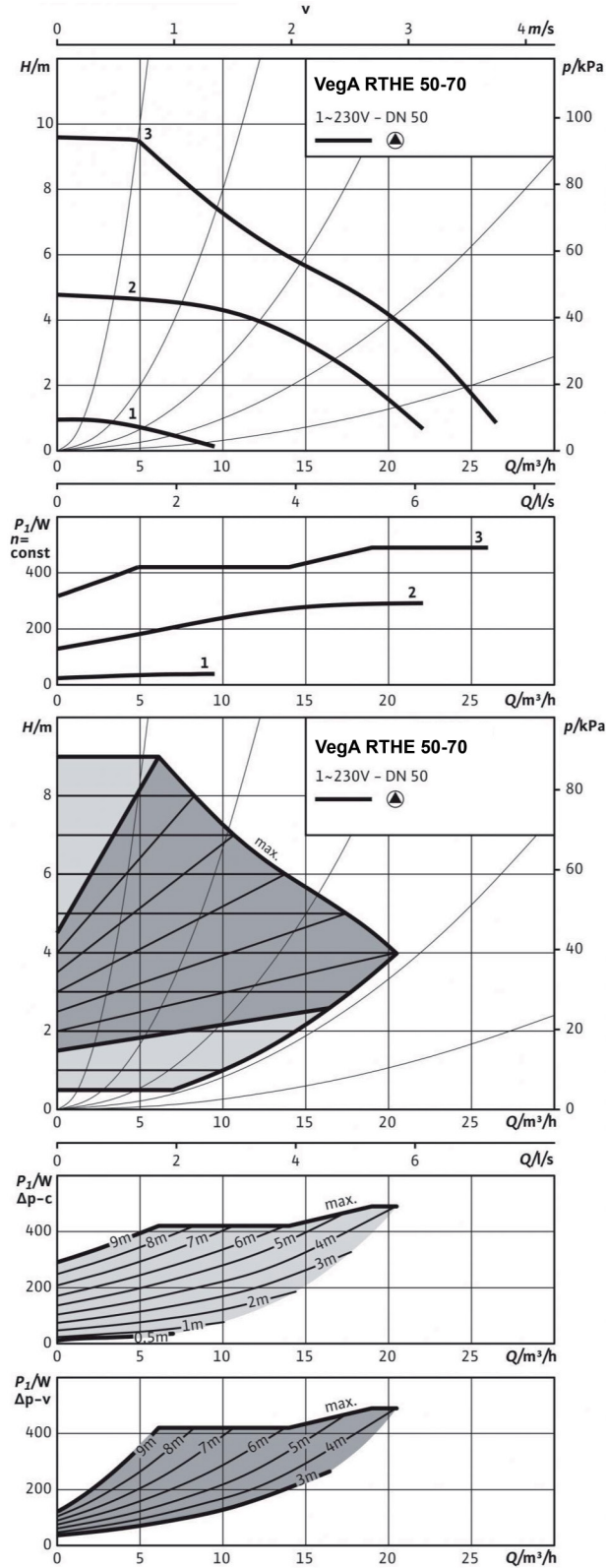

Vega RTHE 50-80 PN6/10

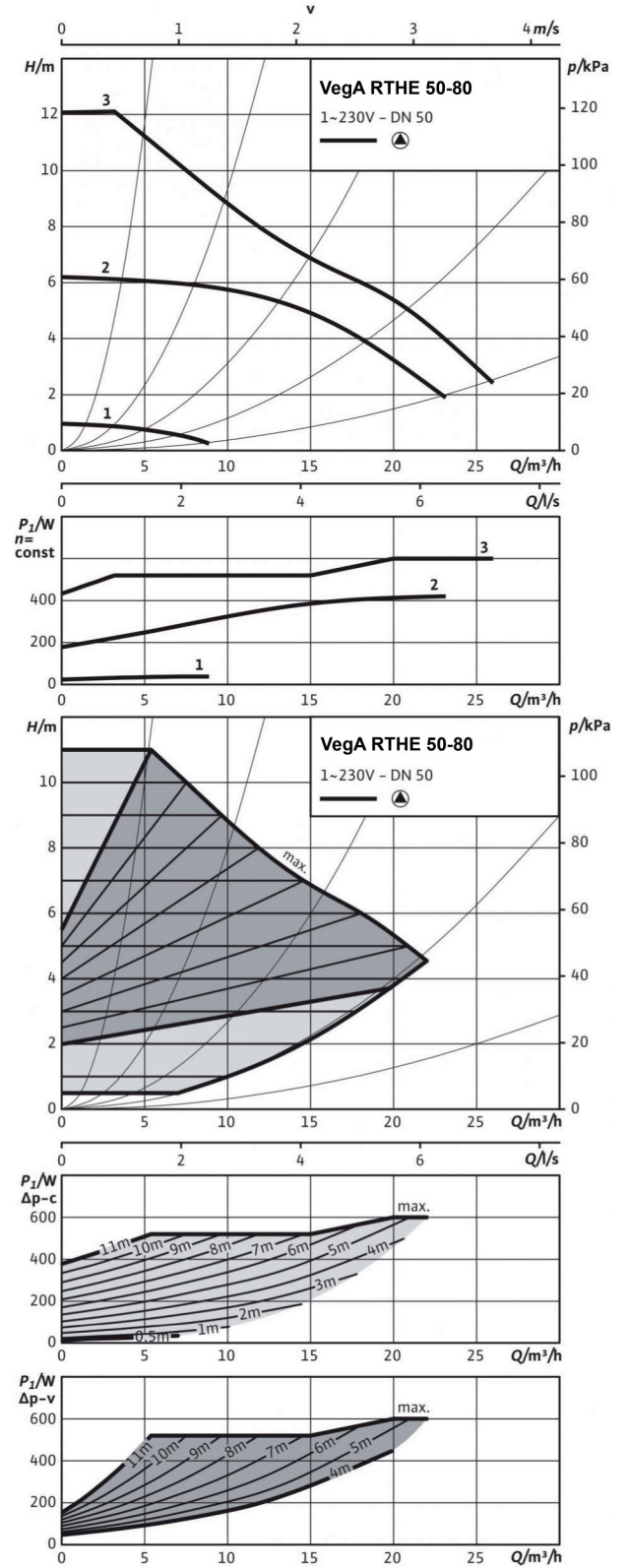

Vega RTHE 50-110 PN6/10

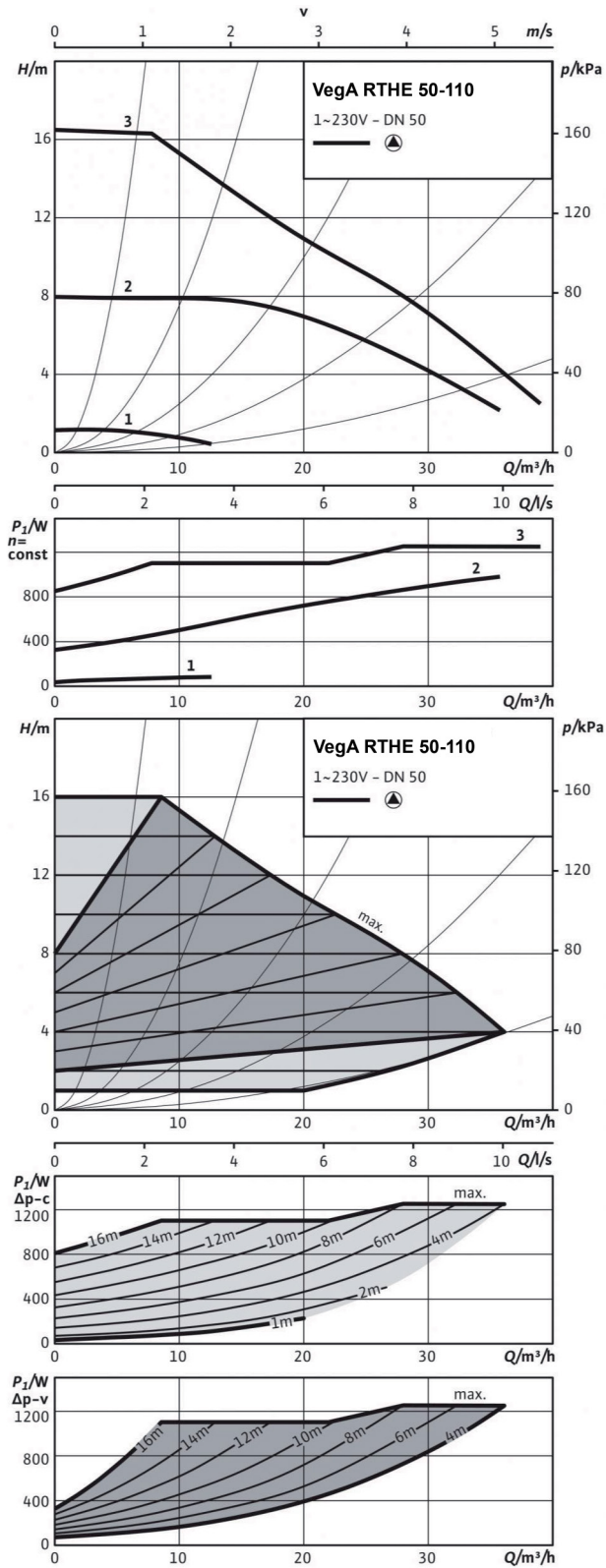

Vega RTHE 65-90 PN6/10

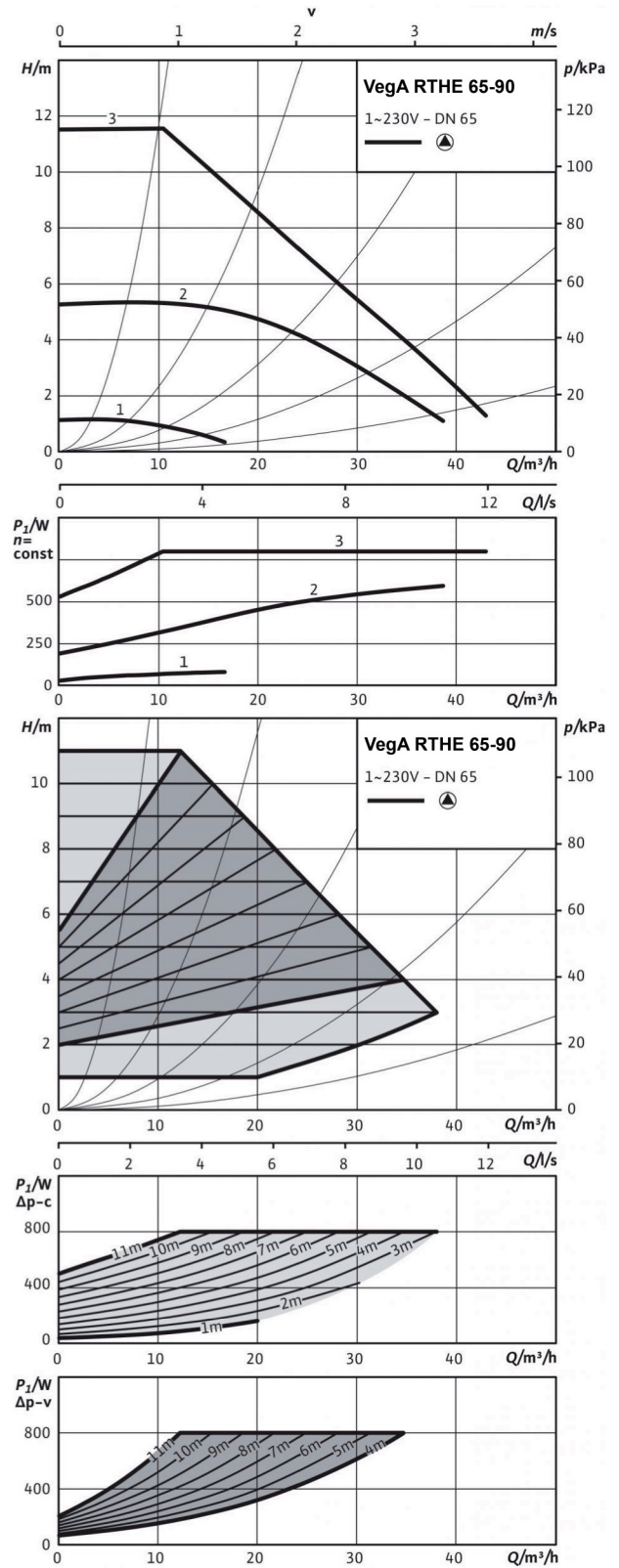

SYSTEM ACCESSORIES

Water circulators

VegA RTHE 80-90 PN6 VegA RTHE 80-90 PN10

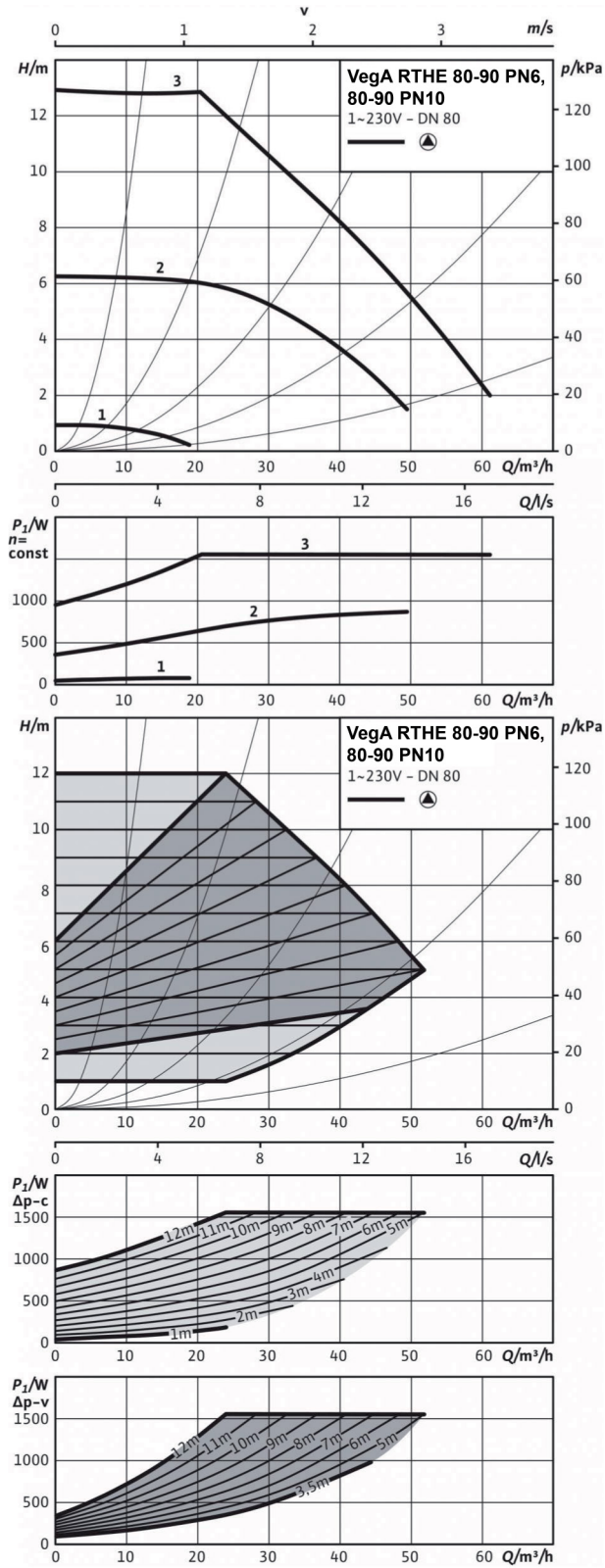

ACCESSORIES

Description	VegA RSHE										VegA RTHE														
	25-60 PN10	25-70 PN10	25-90 PN10	30-60 PN10	30-70 PN10	30-90 PN10	32-70 PN6/10	40-30 PN6/10	40-60 PN6/10	40-80 PN6/10	50-70 PN6/10	50-80 PN6/10	65-80 PN6/10	65-90 PN6/10	65-110 PN6/10	80-90 PN10	32-60 PN6/10	32-80 PN6/10	40-60 PN6/10	40-80 PN6/10	50-70 PN6/10	50-80 PN6/10	50-110 PN6/10	65-90 PN6/10	80-90 PN6

PAIR OF PIPE UNIONS



The steel pipe unions are useful for connecting the threaded pumps to the system piping. The fixed piece has an internal thread for connecting with steel pipes (DIN 2440) with a Whitworth thread (DIN 2999).

The pipe union kit (for one pump) contains:

- 2 flat gaskets
- 2 mobile pipe couplings (brass)
- 2 fixed pieces.

Pipe unions BCT 25 (DN25 – 1"-1½")	•	•	•																								
Pipe unions BCT 32 (DN32 – 1¼"-2")				•	•	•																					

WELDED FLANGE



The (welded) steel flanges are useful for connecting the flanged pumps to the system piping.

The single flange kit contains:

- 1 flat gasket
- 1 counter-flange (GTW, steel)
- Bolts and nuts.

The twin flange kit contains:

- 2 flat gaskets
- 2 counter-flanges (GTW, steel)
- Bolts and nuts.

Welded flange DN32 PN 6							•									•	•										
Welded flange DN40 PN 6								•	•									•	•								
Welded flange DN50 PN 6										•	•								•	•	•						
Welded flange DN65 PN 6												•	•	•											•		
Welded flange DN80 PN 6																										•	
Welded flange DN80 PN 10/16																•											•

FLEXIBLE CENTRE DISTANCE SPACER

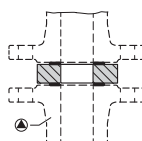

Flexible spacers are used when replacing the circulator, allowing the adaptation of a pump whose centre distance is shorter than the total space available (maintaining the same DN). They are intended for use with flanged models only.

The flexible spacer kits contain:

- 1 flexible spacer
- 2 gaskets
- Bolts and nuts.

Flexible centre distance spacer DN40: 28 mm thick							•	•	•									•	•								
Flexible centre distance spacer DN50: 18 mm thick										•	•									•	•	•					
Flexible centre distance spacer DN65: 28 mm thick												•	•	•													

SYSTEM ACCESSORIES

Water circulators

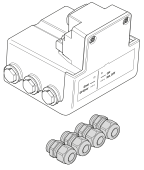
		VegA RSHE														VegA RTHE											
Description																											
	25-60 PN10	25-70 PN10	25-90 PN10	30-60 PN10	30-70 PN10	30-90 PN10	32-70 PN6/10	40-30 PN6/10	40-60 PN6/10	40-80 PN6/10	50-70 PN6/10	50-80 PN6/10	65-80 PN6/10	65-90 PN6/10	65-110 PN6/10	80-90 PN10	32-60 PN6/10	32-80 PN6/10	40-60 PN6/10	40-80 PN6/10	50-70 PN6/10	50-80 PN6/10	50-110 PN6/10	65-90 PN6/10	80-90 PN6	80-90 PN10	
COMMUNICATION MODULE																											
 <p>The communication module extends the pump functions with:</p> <ul style="list-style-type: none"> - A cumulative operating signal with a potential-free NO contact that can be configured for remote access by connection to a building automation system. - A cumulative lockout signal with a potential-free NC contact that can be configured for remote access by connection to a building automation system. - A command input for a potential-free NC contact. - Management of twin pump operation with the addition of the following functions: <ul style="list-style-type: none"> - Main/reserve operation with time-based switching from the main pump to the reserve one (24h). At the time of switching, both pumps are working simultaneously. - Switching to the reserve pump (ready for operation) in the event of a fault. If there is a fault on the operating pump, the system switches to the reserve pump after approx. 3 s. <p>The kit contains:</p> <ul style="list-style-type: none"> - 1 communication module - 4 cable grommets. 																											
	Communication module	•	•	•	•	•	•	•	•	•	•	•	•	•	•	•	•	2x	2x	2x	2x	2x	2x	2x	2x	2x	2x

VegA RSHE – VegA RTHE

PRODUCT DESCRIPTION FOR SPECIFICATIONS

High-performance wet rotor water circulators with extremely low consumption levels, with a thread or flange connection, an EC motor, automatic operation adaptation and a cast iron body. They are purposely designed for all heating systems, air-conditioning systems, closed refrigeration circuits and industrial circulation systems.

FEATURES

The water circulators of the VegA range are characterised by:

- Operating modes
 - $\Delta p-c$ = for constant differential pressure
 - $\Delta p-v$ = for variable differential pressure
 - n = constant (3 speed stages).
- Manual functions
 - Operating mode setting
 - Pump operation setting (discharge head)
 - Speed stage setting
- Automatic functions
 - Modulating adaptation of output on the basis of the operating mode
 - Release function
 - Soft start-up
 - Complete motor protection.
- Signalling and visualisation functions
 - Cumulative lockout signal (potential-free NC contact)
 - Error signal
 - Display with LED segments to view the discharge head values and the error codes
 - Visualisation of the set speed stage (C1, C2 or C3).
- Twin pump function (only for twin models VegA RTHE)
 - Main/reserve operation: the use of the communication module allows the automatic switchover of the pumps in the event of a lockout
 - The pre-selected adjustment type and nominal discharge head must be the same on both pumps.
- Equipment:
 - Coupling for an open-end spanner on the pump body (for threaded pumps)
 - Quick electrical wiring with connector (to connect the mains and SSM cables, with integrated traction discharge)
 - With flanged pumps: flange versions
 - Standard version for pumps from DN 40 to DN 65: PN 6/10 combined flange (PN 16 flange, according to EN 1092-2) for counter-flanges PN 6 and PN 16
 - Standard version for pumps DN 80 / DN 100: PN 6 flange (sized PN 16 according to EN 1092-2) for counter-flange PN 6.
- Materials
 - Pump body: grey cast iron with cathodolysis coating (KTL)
 - Shaft: stainless steel
 - Bearings: carbon impregnated with metal
 - Impeller: synthetic material.
- Supply
 - Pump
 - With gaskets for threaded connection (only for single models VegA RSHE)
 - With washers for flanged screws (for nominal connection diameters DN 40 – DN 65)
 - With assembly, use and maintenance instructions.
- Accessories
 - Pipe unions for threaded connection (only for single models VegA RSHE)
 - Counter-flange with flanged connection
 - Compensation elements
 - Communication module.



RIELLO S.p.A.
Via Ing. Pilade Riello, 7
37045 Legnago (VR)
tel. +39 0442 630111
www.riello.com

The company is constantly working to perfect its entire production range, so the design and size characteristics, technical data, equipment and accessories may vary.

RIELLO